

# High-Accuracy Battery Management Unit Reference Design for 48–1500V Energy Storage System



## Description

This reference design is a high-side, N-channel MOSFET control (up to 32s) battery management unit (BMU), using the stacked BQ769x2 battery monitor family. This design also integrates a CAN interface for BMU stacking high-voltage (up to 1500V) energy storage station applications. High-side, N-channel MOSFET architecture and optimized driving circuits provide easy switch control. This reference design achieves low stand-by and ship-mode consumption and optimizes the current gaps between two groups. This reference design is for 48–1500V energy storage systems.

## Features

- $\pm 1.8\text{mV}$  lithium iron phosphate cell voltage measurement accuracy at  $25^\circ\text{C}$  with fixed offset adjustment
- $7\mu\text{A}$  consumption in ship mode
- Robust and programmable battery cell and system protections
- Reverse charger and high voltage on PACK side
- High-side N-channel MOSFETs and strong driving capability
- Support stacked architecture through CAN up to 1500V

## Resources

<a href="#">TIDA-010247</a>	Design Folder
<a href="#">BQ76972, LM5168, TPS62932</a>	Product Folder
<a href="#">MSPM0G3519</a>	Product Folder
<a href="#">UCC33410, UCC33421-Q1</a>	Product Folder
<a href="#">ISO1640, ISO1042</a>	Product Folder
<a href="#">TPS7A24, TMP61, TPD2E007</a>	Product Folder

## Applications

- [ESS – Battery management system \(BMS\)](#)
- [HEV/EV battery-management system \(BMS\)](#)
- [Other industrial battery pack \(>=10S\)](#)
- [Portable power station](#)

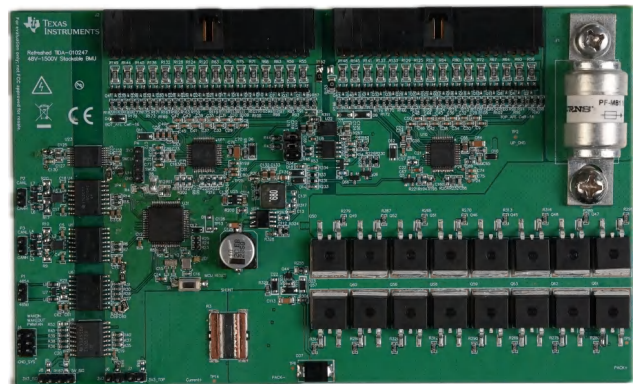
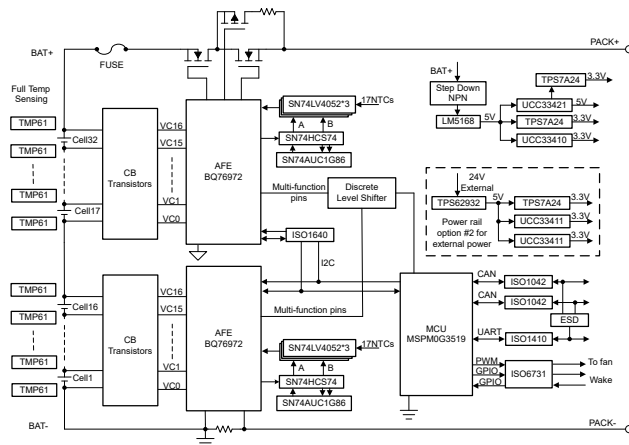
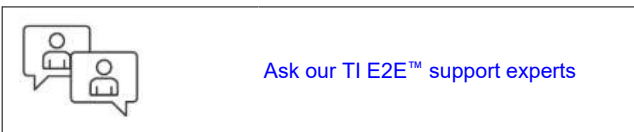

## 1 System Description

Energy storage systems (ESS) play an important role in renewable energy applications. Depending on the system voltage, capacity, and usage, ESS can be divided into three different categories: residential ESS, commercial and industrial ESS, and grid ESS. Commercial and industrial, and grid ESS contain several racks that each contain packs in a stack. Residential ESS only contains packs.

Battery pack which consists of battery cells in a series and parallel connection manner is a basic module comprising the ESS. Because of the weight limit and longer endurance needs, the battery cell chemistry is shifting from Lead-acid to Li-ion, Li-polymer, or Li-ion phosphate (LiFePO<sub>4</sub>) types and the pack voltage is shifting from 24V or 48V to 96V or 192V, or even higher. These battery chemistries are good in both volumetric and gravimetric energy density. While these battery chemistries provide high energy density and thereby lower volume and weight as an advantage, these battery products are associated with safety concerns and have a need for more accurate and complicated monitoring and protections. Those concerns are cell undervoltage (CUV) and cell overvoltage (COV), overtemperature (OT), both overcurrent in charge (OCC) and discharge (OCD), and short-circuit discharge (SCD), all of which contribute to accelerating cell degradation and can lead to thermal runaway and explosion. Therefore, the pack current, cell temperature, and each cell voltage must be monitored in a timely manner in case of unusual situations. The battery pack must be protected against all these situations. Good measurement accuracy is always required, especially the cell voltage, pack current, and cell temperature. Precision is necessary for accurate protections and battery pack state of charge (SoC) calculations. This is especially true for LiFePO<sub>4</sub> battery pack applications because of the flat voltage. Another important feature for battery-powered applications is the current consumption, especially when in ship mode or standby mode. Lower current consumption saves more energy and gives longer storage time without over-discharging the battery.

For the communication interface between BMU, controller area network (CAN) is traditionally and widely used for robustness of communication. A CAN structure controller needs a microcontroller unit (MCU), a digital isolator, and an isolated power module to operate the CAN communication function. Another approach is daisy chain which requires less components than CAN interface for proper work, but this approach needs battery management IC support daisy chain communication, meaning this is a private protocol defined by IC vendors.

This design, with two stacked BQ769x2 battery monitors to cover up to 32s battery cells, focuses on 48V and residential battery pack applications and integrates the CAN interface stacking function for compatibility with high-voltage applications, such as commercial and industrial ESS. The design contains full set protection to protect the battery pack against all unusual situations including: cell overvoltage, cell undervoltage, overtemperature, overcurrent in charge and discharge, and short-circuit discharge. With high-side MOSFET control, normal communication outside is allowed even during faults and MOSFETs in the off status. This design has carefully formed two kinds of auxiliary power architecture, one is for residential ESS and another for commercial and industrial ESS. This design achieves an ultra-low ship mode (10 $\mu$ A) and standby mode (300 $\mu$ A) current consumption with a limited number of components and simple control strategy. This design also contains a thermistor multiplexer circuit to support 32s cell temperature measurement.

## 2 System Overview

### 2.1 Block Diagram

Figure 2-1 shows the system block diagram.

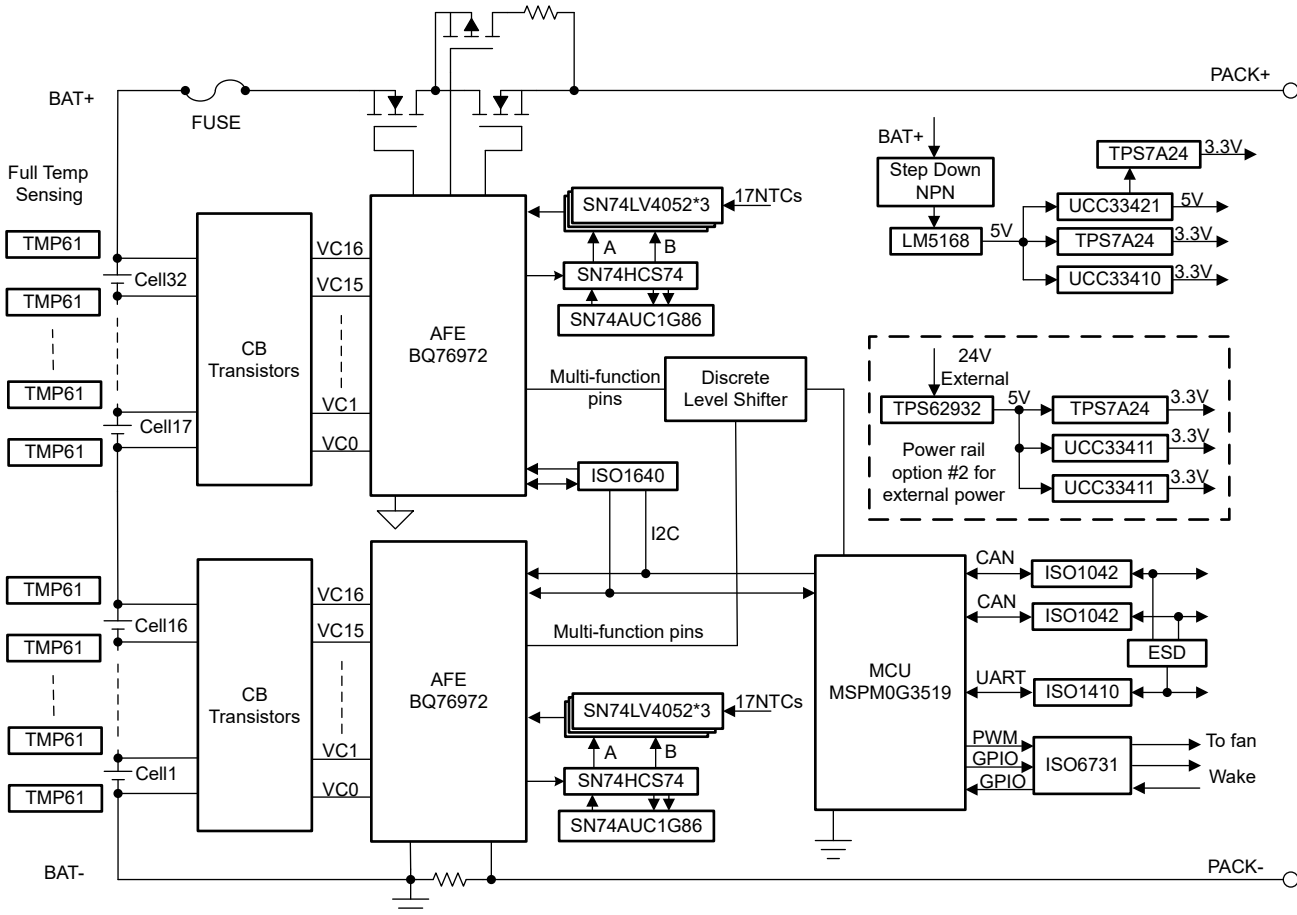

Figure 2-1. TIDA-010247 Block Diagram

The design uses two stacked high-accuracy battery monitor and protector BQ769x2 devices from TI to monitor up to 32 series battery cells voltage, pack current, and temperature data, and protects the battery pack from all unusual situations, including: COV, CUV, OT, OCD, OCC, and SCD. This BQ769x2 family has three devices: BQ76942 to cover 3s to 10s applications, BQ769142 to cover up to 14s applications, BQ76952 to cover up to 16s applications, and the BQ76972 to achieve higher cell voltage measurement accuracy and can also cover up to 16s cells. These are pin-to-pin devices, so updating the design to match different battery cell applications with a limited number of component changes is easy. This design used the BQ76972 for tests.

There is a lower-power MSPM0 MCU MSPM0G3519 which communicates with both BQ76972 devices, deals with all system control strategies, and uploads all the requested information to the system side. Since the top BQ76972 device references the top battery group as ground which is not the same ground with the MCU, isolation is required in the communication between the MCU and the top BQ76972 device. The ISO164x, a hot swappable, low-power, bidirectional isolated I2C interface supporting stable isolated I2C communication.

This design has both an isolated RS-485 transceiver and two isolated CAN transceivers. The isolated CAN transceiver (ISO1042) can operate from 1.8V, 2.5V, 3.3V, and 5V supplies on side 1 and a 5V supply on side 2. The ISO1042 device has an isolation withstand voltage of 5000V<sub>RMS</sub> and is available in basic and reinforced isolation with a surge test voltage of 6kV<sub>PK</sub> and 10kV<sub>PK</sub> respectively. The ISO1410 is an isolated half-duplex RS-485 transceiver that supports interfacing with 1.8V, 2.5V, 3.3V, and 5V control logic.

To power these isolated devices, this design uses a 120V input, 0.3A, ultra-low  $I_Q$  synchronous buck DC/DC converter LM5168 with a low  $I_Q$  as a pre-regulator. The UCC334x(-Q1) family integrates a high-efficiency, low-emissions isolated DC/DC converter. Requiring minimum passive components to form a completely functional DC/DC power module, the UCC334x0 can deliver a maximum power of 1.5W across a 3kV<sub>RMS</sub> basic isolation barrier over a wide range of operating temperatures in a low profile and UCC334x1-Q1 has a 5kV<sub>RMS</sub> reinforced isolation with the same power delivered.

A  $\pm 1\%$ , 10k $\Omega$  linear thermistor with positive temperature coefficient TMP61 is utilized to monitor the cell temperature and is measured by the BQ76972 device.

## 2.2 Design Considerations

### 2.2.1 Configure This Design for Different Use Cases

This product is designed to be used in different kinds of scenarios in ESS. The design can be configured to the BMU with FET control for low-voltage ESS or the stackable BMU with CAN stacking for high-voltage ESS. [Figure 2-2](#) shows the configuration example for low-voltage ESS.

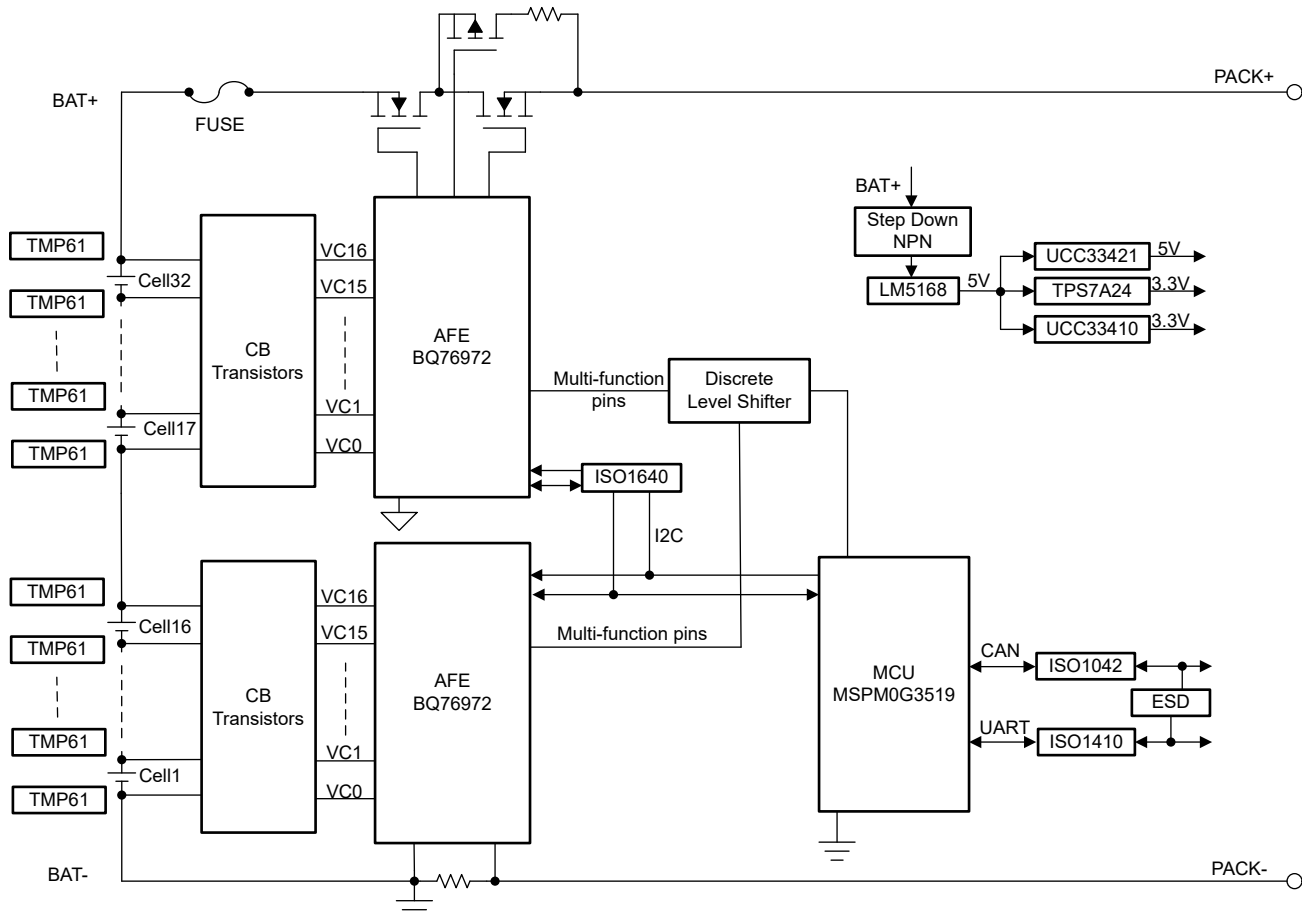

**Figure 2-2. Low-Voltage ESS Configuration**

This configuration removes power rail #2 and uses battery voltage as the auxiliary power input. The thermistor multiplexer circuit is removed because low-voltage ESS typically does not need to measure every cell temperature and needs some multifunction pins for FET control or alarm output. The number of thermistors can be changed case by case. ISO6731 is removed because CAN stacking is not needed in a single-pack application. Stacking two BQ76972 devices can support up to 32s battery pack, the design can also be used for 16s battery pack by removing one BQ76972. [Figure 2-3](#) shows the configuration example for high-voltage ESS.

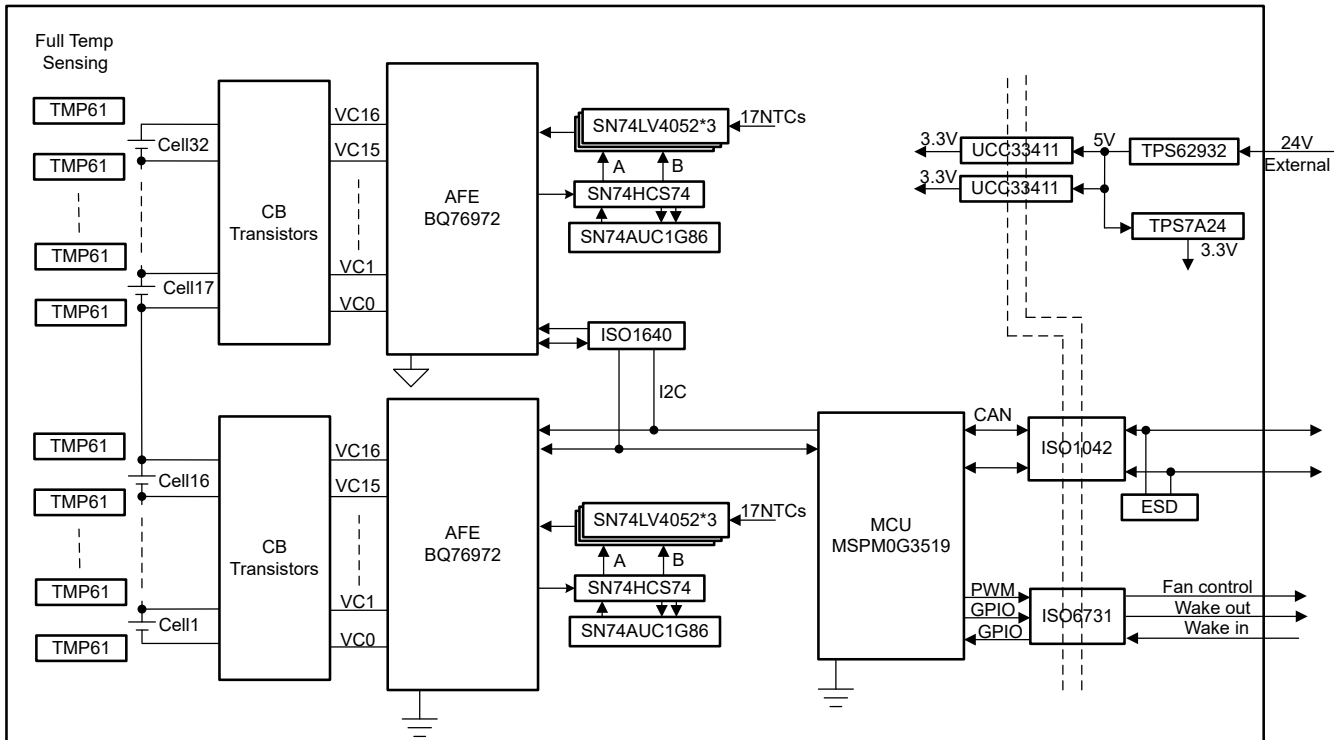

Figure 2-3. High-Voltage ESS Configuration

For high-voltage ESS, each single BMU is powered by external auxiliary power and the protection FET is controlled by a battery control unit (BCU). This configuration shows a typical 32s stackable BMU for high-voltage ESS. The design can be stacked with a CAN interface and also provides a fan control signal for an air-cooled ESS application.

### 2.2.2 Auxiliary Power Strategy

With the requests of low current consumption and good thermal performance in normal mode and ship mode, this design uses two kinds of auxiliary power strategies for high-voltage and low-voltage ESS. Figure 2-4 shows the strategy for low-voltage ESS.

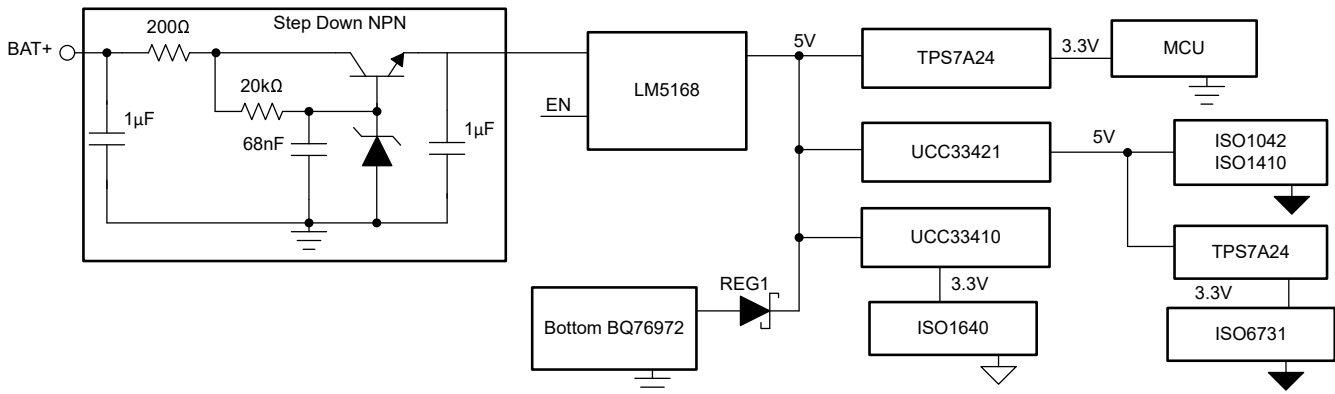

Figure 2-4. Auxiliary Power Strategy for Low-Voltage ESS

The low-voltage ESS power strategy has a 120V input, 0.3A, ultra-low  $I_Q$  synchronous buck DC/DC converter LM5168P with a low  $I_Q$  0.3A LDO TPS7A25 as the main power source when the system is working in normal mode which requires hundreds of mA with normal CAN or RS-485 communications on the system side, giving the system better efficiency and thermal performance than LDOs only. A discrete step-down circuit is added before DC/DC because the 32s battery pack voltage can exceed 120V.

When the system experiences a serious cell undervoltage and must enter ship mode, the MCU configures both of the BQ76972 devices to enter shutdown mode through an I2C command or RST\_SHUT pin and turns off the LM5168P output through the EN pin, which configures the system to very-low-current consumption mode. This design supports both charger attach and system attach wake up functions. Both methods wake up the bottom BQ76972 device and enable normal 3.3V regulator REG1, then the MCU is powered on and enables the LM5168P through the EN pin.

To cover 32s battery systems, two stacked BQ76972 devices are used to monitor cell voltage and temperature. Avoiding an imbalance between the two stacked groups is important for longer battery life. Although cell balancing is useful to balance the voltage of all the battery cells equally, the best way is to avoid too much load gap between the two groups. In this design, ISO1640, an isolated I2C interface, is used for communication between the MCU and the top BQ76972 device. A small supply current gap between VCC1 and VCC2 of the ISO1640 benefits the system.

For low-voltage ESS, this design uses a cost-optimized, basic isolated power module UCC33410 to power ISO1640 to avoid the imbalance between the two stacked groups. Figure 2-5 shows the power rail for high-voltage ESS.

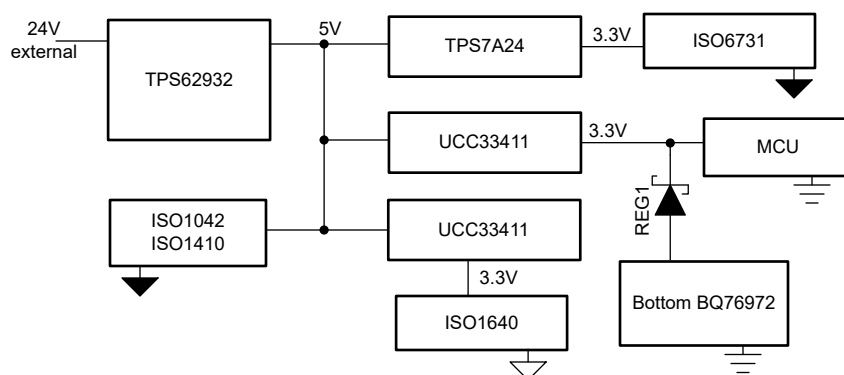

**Figure 2-5. Auxiliary Power Strategy for High-Voltage ESS**

Different from low-voltage ESS, there typically is an external pre-regulator to convert the grid voltage to 24V DC voltage to power all subsystems. Also, the isolation design is more stringent than low-voltage ESS due to the safety considerations. This design considers 8mm creepage reinforced isolation design so the design can be used in up to 1500V systems with proper protective grounding.

### 2.2.3 High-Side N-Channel MOSFET

This design supports high-side N-channel MOSFET architecture and uses the top BQ76972 charge pump to drive the MOSFETs. Since the top BQ76972 references the top of the bottom stack for cell-voltage measurement, when the top BQ76972 device turns DSG MOSFET off, the voltage on the DSG pin of the top BQ76972 device is the bottom stack voltage, which is too high to completely turn the DSG MOSFET off. This reference design adds some discrete components to make sure the DSG MOSFET turns off completely and quickly.

When DSG MOSFETs need to be off, the MCU or the bottom BQ76972 device turns on Q65. P-channel MOSFET Q54 is turned on to discharge  $V_{GS}$  of DSG MOSFET. The top BQ76972 drives TOP\_DSG towards TOP\_LD to turn off Q64, allowing Dri\_Test to ground and turn off DSG MOSFET completely. When DSG MOSFET is off, Q65 is able to turn off to save power. When the system needs to turn on DSG MOSFET, the system first makes sure Q65 is off and then drives TOP\_DSG with the charge pump voltage, Q64 is on and charges  $V_{GS}$  of DSG MOSFET.

### **2.2.4 Stacked AFE Communication**

To cover a 16s battery cell system or greater, two BQ769x2 devices can be cascaded to monitor up to 32s battery cells. This design tests two BQ76972 devices to monitor up to 32s battery cells. The bottom BQ76972 monitors the lower 16s battery cells and the top BQ76972 monitors the upper 16s battery cells, so the bottom BQ76972 shares the same ground with BAT– and MCU while the top BQ76972 references 16s stack voltage. Adding isolation is required when communicating with the top BQ76972 device or a discrete level shifter can be used here. This design uses an I2C isolator, ISO164x, for up to 400kHz I2C communication baud rate and low power consumption. Using the discrete level shifter is acceptable for other signals like ALERT, RST\_SHUT, DFETOFF, CFETOFF, and so forth, since these signals are not acting frequently. MCU issues commands and reads voltage, current, and temperature data from the bottom BQ76972 directly and through ISO164x when communicating with the top BQ76972.

For the faults in the upper 16s battery cells, the top BQ76972 detects the faults and drives MOSFET off directly. The MCU can be made aware through ALERT or reading status registers and turn on Q65, to make sure DSG MOSFET is completely off. For the faults in the lower 16s battery cells and current faults, the bottom BQ76972 detects them and informs the top BQ76972 to drive MOSFET off. For slow protections, like COV, CUV, OT, UT, OCD1, OCD2, alerting the MCU is acceptable when faults are triggered and the MCU then issues a command to turn off MOSFETs. While for short-circuit protections, which normally requires  $\mu$ s delay time, the process is not fast enough if leveraging MCU firmware for the protections. This design adds discrete circuits to allow the bottom BQ76972 device to control MOSFET directly with the top BQ76972 device, avoiding further protection delay caused by MCU firmware.

### **2.2.5 Thermistor Multiplexer**

Each BQ76972 provides nine pins which can support external thermistors. Most of these pins also can support other features which can be required in the system, such as the Alarm interrupt to the host processor, or a hardware pin-control for FET turnoff. If an application requires support for more thermistors than the BQ76972 can natively support, additional multiplexer circuitry can be included to enable this, as [Figure 2-6](#) shows.

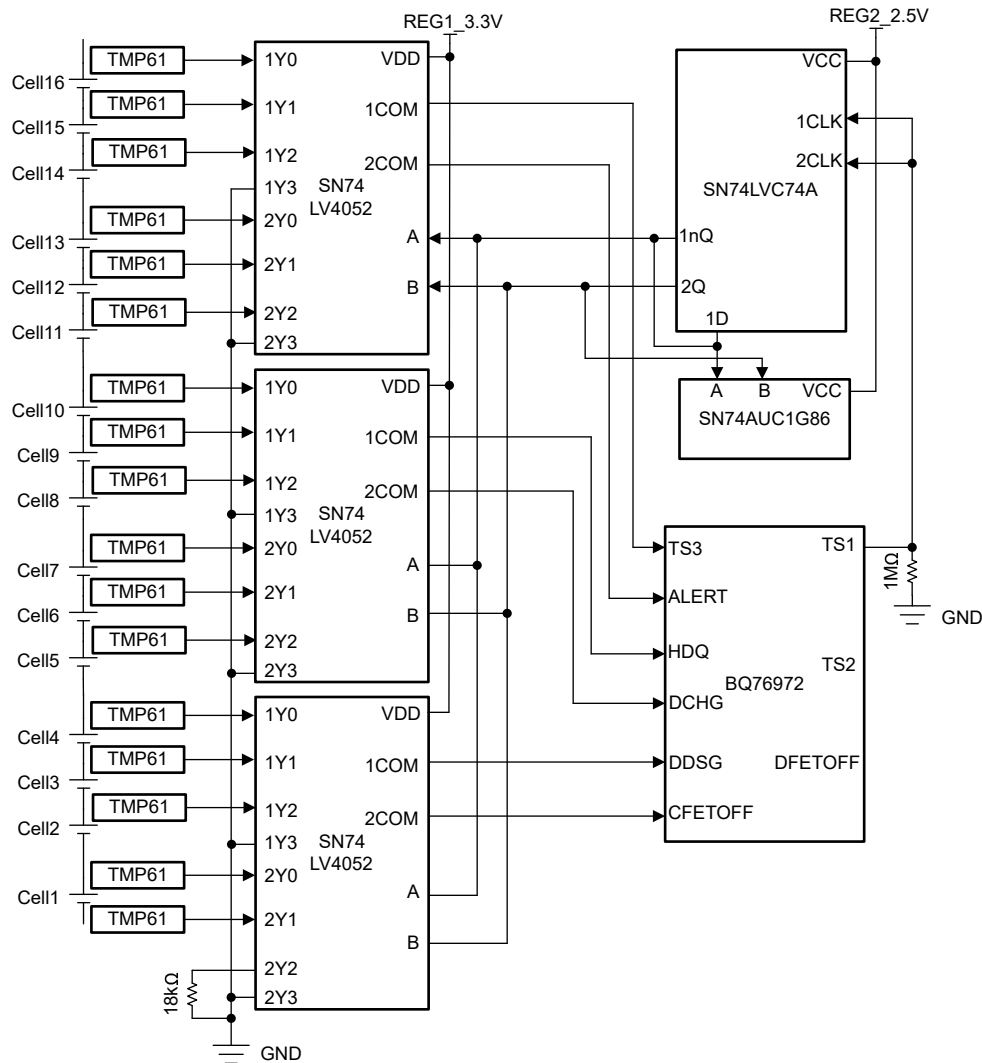

Figure 2-6. Thermistor Multiplexer Block Diagram

Typically, only high-voltage ESS requires more than 9 thermistors measurement for one BQ76972 and do not need these pins configured for other functions so this design only shows the implementation of the thermistor multiplexer when all 9 pins are configured as thermistor inputs. A total of 17 thermistors are measured by one BQ76972 in this design. There are also many variants if the designer wants to reserve some pins for other purposes. These circuits can be modified based on the basic principles demonstrated in the rest of this section.

Figure 2-7 illustrates how the BQ76972 ADC measurements are performed using a continuous repeating loop in normal mode, such that after the device completes each set of measurements, the device immediately initiates a new set of measurements. Each measurement loop (ADCSCAN) contains up to 21 measurement slots. The  $t_{meas}$  slot time default is 3ms, but you can reduce that time to 1.5ms by setting the [FASTADC] bit, with a reduction in conversion resolution. One ADCSCAN takes 31.5ms (FASTADC = 1) or 63ms (FASTADC = 0).

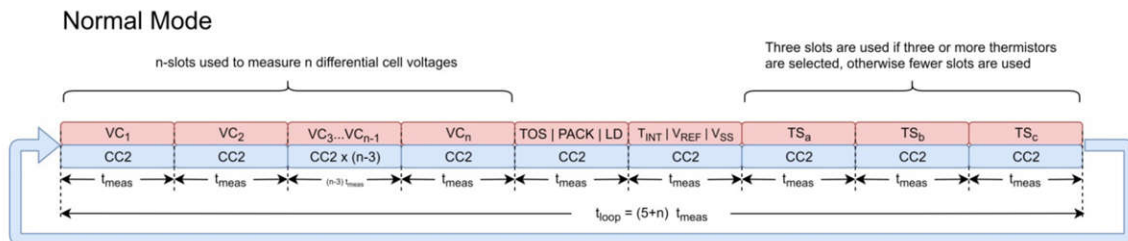

Figure 2-7. BQ76972 NORMAL Mode Measurement Loop



Because this design configures 9 pins as thermistor inputs, the design takes 3 ADCSCAN to measure 9 pins, called as FULLSCAN. One FULLSCAN cycle duration is 94.5ms (FASTADC = 1) or 189ms (FASTADC = 0). This design uses a 4:1 multiplexer to measure 17 thermistors so one full temperature sensing cycle (FULLTEMP) takes 378ms (FASTADC = 1) or 756ms (FASTADC = 1). See also the [Improving Voltage Measurement Accuracy in Battery Monitoring Systems](#) technical article.

The timing of when the MUX is changed requires some coordination with the regular measurement loop of the BQ76972, to avoid a corrupted measurement if the MUX was changed in the middle of a measurement. This design uses an approach to automatically control the timing of the MUX changes, shown in [Figure 2-6](#). The TS1 pin is used with a dummy 1MΩ resistor to generate the *clock* signal for an external binary counter that counts 0 to 3. The count controls a multiplexer that switches 3 thermistors and 1 ground on each MUX into one of 6 pins, thus supporting a maximum of 18 total thermistors. The ground channel is used for multiplexer circuit diagnostic, meaning the multiplexer works correctly if you can see a ground detection every four measurements on one pin. One of the 18 channels is connected to a high-accuracy fix resistor for temperature measurement calibration.

The 9 pins are measured in the sequence of CFETOFF, DFETOFF, ALERT, TS1, TS2, TS3, HDQ, DCHG, and DDSG, but BQ76972 only measures the pins that are configured as thermistor inputs. As TS1 is used as clock input, TS2 is not used as a real thermistor to avoid any MUX settling transients that can affect the measurement because TS2 is measured immediately after the TS1 pin.

Implement the thermistor-related temperature protections through the host microcontroller because the pin temperature of the BQ76972 moves between 3 thermistors and 1 ground.

A silicon linear thermistor has a linear positive temperature coefficient (PTC), TMP61, is used in this design for better temperature measurement accuracy. Unlike an NTC, which is a purely resistive device, the TMP61 resistance is affected by the current across the device and the resistance changes when the temperature changes. The TMP61 has good linear behavior across the whole temperature range. This range allows a simpler resistance-to-temperature conversion method that reduces look-up table memory requirements. The linearization circuitry or midpoint calibration associated with traditional NTCs is not necessary with the device. The linear resistance across the entire temperature range allows the device to maintain sensitivity at higher operating temperatures. [How to Achieve ±1°C Accuracy or Better Across Temperature With Low-Cost TMP6x Linear Thermistors](#) shows how to achieve the best accuracy with TMP61.

### 2.2.6 CAN Stacking

The CAN interface can be used for communication between the BMU to stack the battery packs for high-cell-count systems, but address the CAN interface to a different ID because the default BMU CAN node ID is the same. [Figure 2-8](#) shows the design using a hardwire wake-up CAN auto address.

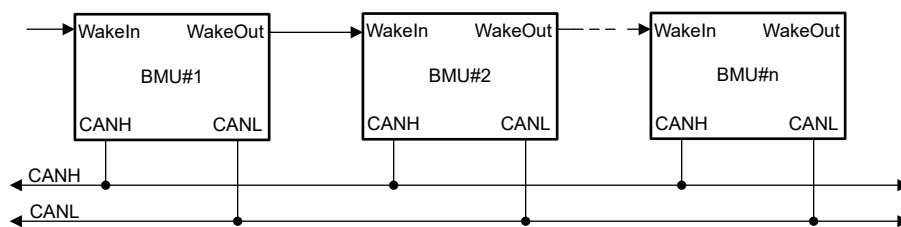
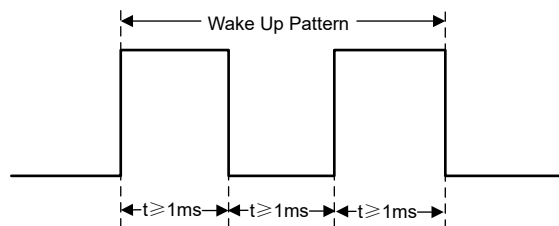

Figure 2-8. CAN Bus Stacking Block Diagram

BMUs are cascaded and waked up one by one. Every BMU has a wake input signal for waking and a wake output signal for waking the next BMU. The initial CAN node ID is defined by the host microcontroller. The BMU keeps monitoring the CAN frame for when to be waked up and uses the ID in data field as an ID, then sends ID+1 CAN frame to the CAN BUS and wake out signal through GPIO. [Figure 2-9](#) shows a method where the wake signal pattern meets the timing for a more robust design.



**Figure 2-9. Wake-Up Pattern**

## 2.3 Highlighted Products

### 2.3.1 BQ76972

The TI BQ76972 is a highly integrated, high-accuracy battery monitor and protector for 3-series to 16-series Li-ion, Li-polymer, and LiFePO<sub>4</sub> battery packs. The device includes a high-accuracy monitoring system, a highly configurable protection subsystem, and support for autonomous or host-controlled cell balancing. Integration includes high-side charge-pump NFET drivers, dual-programmable LDOs for external system use, and a host communication peripheral supporting 400kHz I<sup>2</sup>C, SPI, and HDQ one-wire standards. The BQ76972 is available in a 48-pin TQFP package.

### 2.3.2 MSPM0G3519

MSPM0G351x microcontrollers (MCUs) are part of the MSP highly integrated, ultra-low-power 32-bit MCU family based on the enhanced Arm<sup>®</sup> Cortex<sup>®</sup>-M0+ 32-bit core platform, operating at up to 80MHz frequency. These MCUs offer a blend of cost optimization and design flexibility for applications requiring 256KB to 512KB of flash memory. These devices include dual CAN-FD controllers, cybersecurity enablers, high-performance integrated analog, and provide excellent low-power performance across the operating temperature range. The TI MSPM0 family of low-power MCUs consists of devices with varying degrees of analog and digital integration allowing for customers to find the MCU that meets the needs of the project. The MSPM0 MCU platform combines the Arm Cortex-M0+ platform with a holistic ultra-low-power system architecture, allowing system designers to increase performance while reducing energy consumption. MSPM0G351x MCUs are supported by an extensive hardware and software ecosystem with reference designs and code examples to get the design started quickly.

### 2.3.3 UCC334xx

The UCC334xx(-Q1) family integrates a high-efficiency, low-emissions isolated DC/DC converter. Requiring minimum passive components to form a completely functional DC/DC power module, the UCC334x0 can deliver a maximum power of 1.5W across a  $3\text{kV}_{\text{RMS}}$  basic isolation barrier over a wide range of operating temperatures in a low profile and UCC334x1-Q1 has a  $5\text{kV}_{\text{RMS}}$  reinforced isolation with the same power delivered. The easy-to-use feature, low profile and high power density promotes this device for size-limited, cost-sensitive systems with a minimum design effort replacing bulky and expensive transformer-based designs. The integrated DC/DC converter uses switched mode operation and proprietary circuit techniques to reduce power losses and boost efficiency across all loading conditions. Specialized control mechanisms, clocking schemes, and the use of an on-chip transformer provide high efficiency and low radiated emissions.

### 2.3.4 LM5168

The LM5169 and LM5168 synchronous buck converters are designed to regulate over a wide input voltage range, minimizing the need for external surge suppression components. A minimum controllable on time of 50ns facilitates large step-down conversion ratios, enabling the direct step-down from a 48V nominal input to low-voltage rails for reduced system complexity and design cost. The LM516x operates during input voltage dips as low as 6V, at nearly 100% duty cycle if needed, making the device an excellent choice for a wide input supply range industrial and high cell count battery pack applications. With integrated high-side and low-side power MOSFETs, the LM5169 delivers up to 0.65A of output current and the LM5168 delivers up to 0.3A of output current. A constant on-time (COT) control architecture provides nearly constant switching frequency with excellent load and line transient response. The LM516x is available in FPWM or auto mode versions. FPWM mode provides forced CCM operation across the entire load range supporting isolated fly-buck converter applications. Auto mode enables ultra-low  $I_Q$  and diode emulation mode operation for high light-load efficiency.

### 2.3.5 ISO1640

The ISO1640, ISO1641, ISO1642, ISO1643, and ISO1644 (ISO164x) devices are hot-swappable, low-power, bidirectional isolators that are compatible with I2C interfaces. The ISO164x supports UL 1577 isolation ratings of  $5000\text{V}_{\text{RMS}}$  in the 16-DW package, and  $3000\text{V}_{\text{RMS}}$  in the 8-D package. Each I2C isolation channel in this low emissions device has a logic input and open drain output separated by a double capacitive silicon dioxide ( $\text{SiO}_2$ ) insulation barrier. The ISO1642 and ISO1643 integrates two unidirectional CMOS isolation channels, while the ISO1644 integrates three unidirectional CMOS isolation channels which can be used for static GPIO isolation or to isolate a Serial Peripheral Interface (SPI) bus. This family includes basic and reinforced insulation devices certified by VDE, UL, CSA, TUV, and CQC. The ISO1640, ISO1642, ISO1643, and ISO1644 have two isolated bidirectional channels for clock and data lines and the ISO1641 has a bidirectional data and a unidirectional clock channel. The ISO164x family integrates logic required to support bidirectional channels, providing a much simpler design and smaller footprint when compared to optocoupler-based designs.

### 2.3.6 ISO1042

The ISO1042 device is a galvanically-isolated controller area network (CAN) transceiver that meets the specifications of the ISO11898-2 (2016) standard. The ISO1042 device offers  $\pm 70\text{V}_{\text{DC}}$  bus fault protection and  $\pm 30\text{V}$  common-mode voltage range. The device supports up to 5Mbps data rate in CAN FD mode allowing much faster transfer of payload compared to classic CAN. This device uses a silicon dioxide ( $\text{SiO}_2$ ) insulation barrier with a withstand voltage of  $5000\text{V}_{\text{RMS}}$  and a working voltage of  $1060\text{V}_{\text{RMS}}$ . Electromagnetic compatibility has been significantly enhanced to enabled system-level ESD, EFT, surge, and emissions compliance. Used in conjunction with isolated power supplies, the device protects against high voltage, and prevents noise currents from the bus from entering the local ground. The ISO1042 device is available for both basic and reinforced isolation.

### 2.3.7 ISO1410

The ISO14xx devices are galvanically-isolated differential line transceivers for TIA, EIA RS-485, and RS-422 applications. These noise-immune transceivers are designed to operate in harsh industrial environments. The bus pins of these devices can endure high levels of IEC electrostatic discharge (ESD) and IEC electrical fast transient (EFT) events which eliminates the need for additional components on the bus for system-level protection. The devices are available for both basic and reinforced isolation.

### 2.3.8 TPS7A24

The TPS7A24 low-dropout (LDO) linear voltage regulator introduces a combination of a 2.4V to 18V input voltage range with very-low quiescent current ( $I_Q$ ). These features help modern appliances meet increasingly stringent energy requirements, and help extend battery life in portable-power designs. The TPS7A24 is available in both fixed and adjustable versions. For more flexibility or higher output voltages, the adjustable version uses feedback resistors to set the output voltage from 1.24V to 17.64V. Both versions have a 1% output regulation accuracy that provides precision regulation for most microcontroller (MCU) references. The TPS7A24 LDO operates more efficiently than standard linear regulators because the maximum dropout voltage is less than 340mV at 200mA of current. This maximum dropout voltage allows for 92.5% efficiency from a 5.4V input voltage ( $V_{IN}$ ) to a 5.0V output voltage ( $V_{OUT}$ ). The power-good (PG) indicator can be used to either hold an MCU in reset until power is good, or for sequencing. The PG pin is an open-drain output; therefore, the pin is easily level-shifted for monitoring by a rail other than  $V_{OUT}$ . The built-in current limit and thermal shutdown help protect the regulator in the event of a load short or fault. For a higher output current alternative, consider the TPS7A25 or TPS7A26.

### 2.3.9 TMP61

The Thermistor Design Tool, offers complete resistance vs temperature table (RT table) computation, and other helpful methods to derive temperature and example C-code. The TMP61 linear thermistor offers linearity and consistent sensitivity across temperature to enable simple and accurate methods for temperature conversion. The low power consumption and a small thermal mass of the device minimizes the impact of self-heating. With built-in fail-safe behaviors at high temperatures and powerful immunity to environmental variation, these devices are designed for a long lifetime of high performance. The small size of the TMP6 series also allows for close placement to heat sources and quick response times. Take advantage of benefits over NTC thermistors such as no extra linearization circuitry, minimized calibration, less resistance tolerance variation, larger sensitivity at high temperatures, and simplified conversion methods to save time and memory in the processor. The TMP61 is currently available in a 0402 footprint-compatible X1SON package, a 0603 footprint-compatible SOT-5X3 package, and a 2-pin through-hole TO-92S package.

### 2.3.10 TPD2E007

This device is a transient-voltage suppressor (TVS) based electrostatic discharge (ESD) protection device designed to offer system-level ESD protections for a wide range of portable and industrial applications. The back-to-back diode array allows AC-coupled or negative-going data transmission (audio interface, LVDS, RS-485, RS-232, and so forth) without compromising signal integrity. This device exceeds the IEC 61000-4-2 (Level 4) ESD protection and is designed for providing system-level ESD protection for the internal ICs when placed near the connector. The TPD2E007 is offered in 4-bump PicoStar and 3-pin SOT (DGK) packages. The PicoStar package (YFM), with only 0.15mm (maximum) package height, is recommended for ultra space-saving applications where the package height is a key concern. The PicoStar package can be used in either embedded PCB board applications or in surface mount applications. The industry-standard SOT package offers straightforward board layout option in legacy designs.

### 3 Hardware, Software, Testing Requirements, and Test Results

The key performances of the TIDA-010247 are tested in a TI lab, the end equipment used and test processes and results are described in this section.

Table 3-1 describes the connections for the TIDA-010247 board.

**Table 3-1. Board Connections**

CONNECTOR AND PIN ASSIGNMENTS	FUNCTION OR SCHEMATIC NET	NOTES
BAT+	BAT+	Cell stack positive
BAT-	BAT-	Cell stack negative; this provides a reference for the electronics and the high current path from the cells
PACK+	PACK+	Charger positive or load positive
PACK-	PACK-	Charger negative or load negative
P1-1	RS-485-A	RS-485 Bus I/O port, A
P1-2	RS-485-B	RS-485 Bus I/O port, B
P2-1	CAN1-H	High-level CAN1 BUS
P2-2	CAN1-L	Low-level CAN1 BUS
P3-1	CAN0-H	High-level CAN0 BUS
P3-2	CAN0-L	Low-level CAN0 BUS
J1	Cn	(n = 0 to 16) Cell monitor, balance, and electronics power connections. Top 16 series cells
J2	Cn	(n = 0 to 16) Cell monitor, balance, and electronics power connections. Bottom 16 series cells
J3-1	SCL MCU	I2C communication SCL from MCU
J3-2	SDA MCU	I2C communication SDA from MCU
J4-1	Fan_Control	Fan control PWM signal
J4-3	WakeOut	CAN wake output signal for addressing
J4-5	WakeIn	CAN wake input signal for addressing
J5-1	24V_EXT	24V external power input port
J12	Debug	MSPM0 program connector

#### 3.1 Hardware Requirements

Table 3-2 summarizes the equipment used for testing.

**Table 3-2. Test Equipment Summary**

EQUIPMENT	MODEL OR DESCRIPTION
Oscilloscope	Tektronix DPO 2024B
DC power supply	Chroma 62050P-100-100
Electronic load	Chroma 63106
Multimeter	Agilent 34401A
DC power supply	GW INSTEK GPS-3303C
Communication adapter	Texas Instruments EV2300 or EV2400
MSPM0 programmer	XDS110
ESD simulator	NoiseKen ESS-S3011

The *Battery Management Studio (bqStudio) Software* is recommended when debugging the board for the first time.

## 3.2 Software Requirements

### 3.2.1 Getting Started MSPM0 Software

Using this TI reference design requires the MSPM0 development environment. This section contains the steps using the Code Composer Studio™ with MSPM0 SDK. Developing MSPM0 software with the Arm® Keil® microcontroller development kit (MDK) or IAR software also requires installing the System Configuration Tool.

Use the following download links to access the software:

- CCS: [Code Composer Studio integrated development environment \(IDE\)](#).
- MSPM0 SDK: [MSPM0 software development kit \(SDK\)](#).
- SysConfig: [System configuration tool](#).

For the detailed environment setup guide, see also the [MSPM0 Design Flow Guide](#) application report.

After installing the MSPM0 SDK and CCS, find the source code from MSPM0 SDK at:

```
<install_location>\ti\mspm0_sdk_2_03_00_02\examples\nortos\LP_MSPM0G3519\demos\bq769x2_TIDA010247
```

#### 3.2.1.1 Download and Install Software Required for Board Test

1. Download and install [MSPM0-SDK](#), mspm0\_sdk\_2\_03\_00\_02 or newer software from the link provide by TI.
2. Download and install [CCS](#), for CCSTheia Version 1.5.1 or newer, and for CCS Version: 12.8.1 or newer.
3. Download and install [SYSCONFIG](#), Version 1.21.2 or newer, this step is optional, if developing MSPM0 in Keil MDK or IAR, a standalone version of SYSCONFIG must be installed from the link provided by TI. If developing MSPM0 in CCS, click the MSPM0 support option during CCS installation, SYSCONFIG is installed automatically with CCS installation.

Once installation is complete, open CCS and create a new workspace for importing the project.

#### 3.2.1.2 Import the Project Into CCS

Open CCS, and select *Project* → *Import CCS Project*, browse to choose the *bq769x2\_TIDA010247* folder from MSPM0 SDK. [Figure 3-1](#) shows the Import CCS Projects windows of CCS. Select the project and click the *Finish* button to import this project.

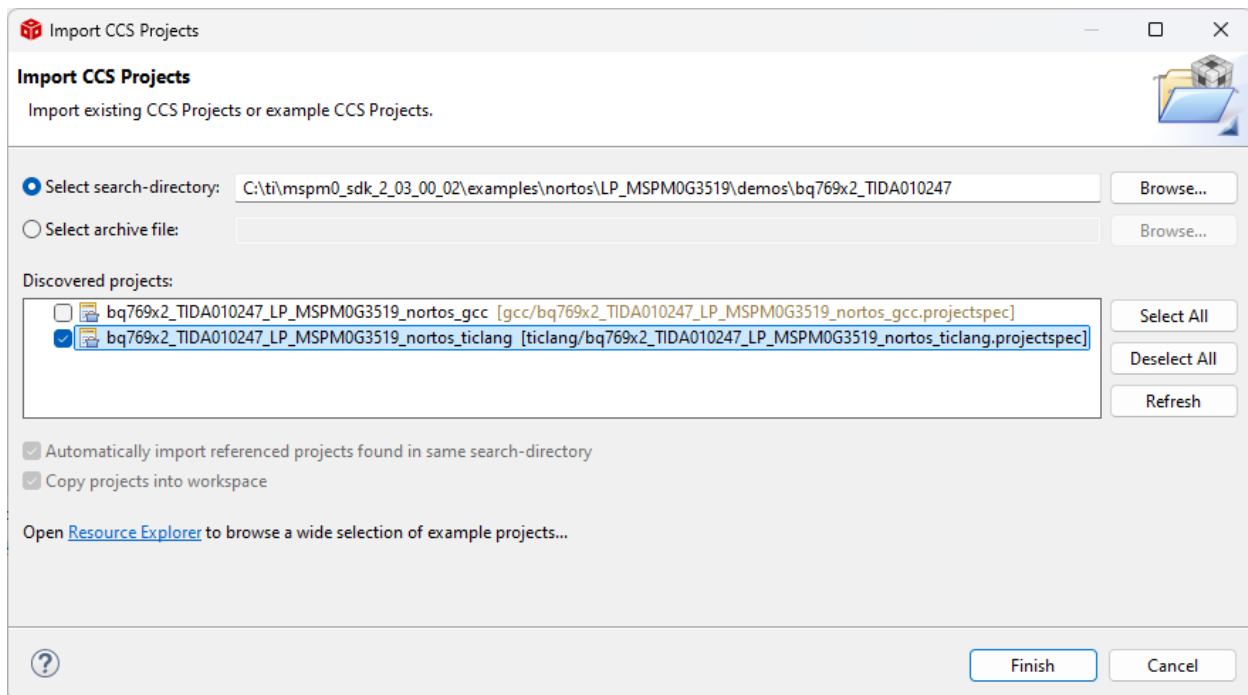

**Figure 3-1. Import the Project**

### 3.2.1.3 Compile the Project

Click the project name or open the project main.c file, to activate this project. Click the *Build* button or select the *Project* → *Build Project* menu. The .out file is generated after compilation finishes, and is shown in the *Console* window in CCS. [Figure 3-2](#) shows the resulting project build.

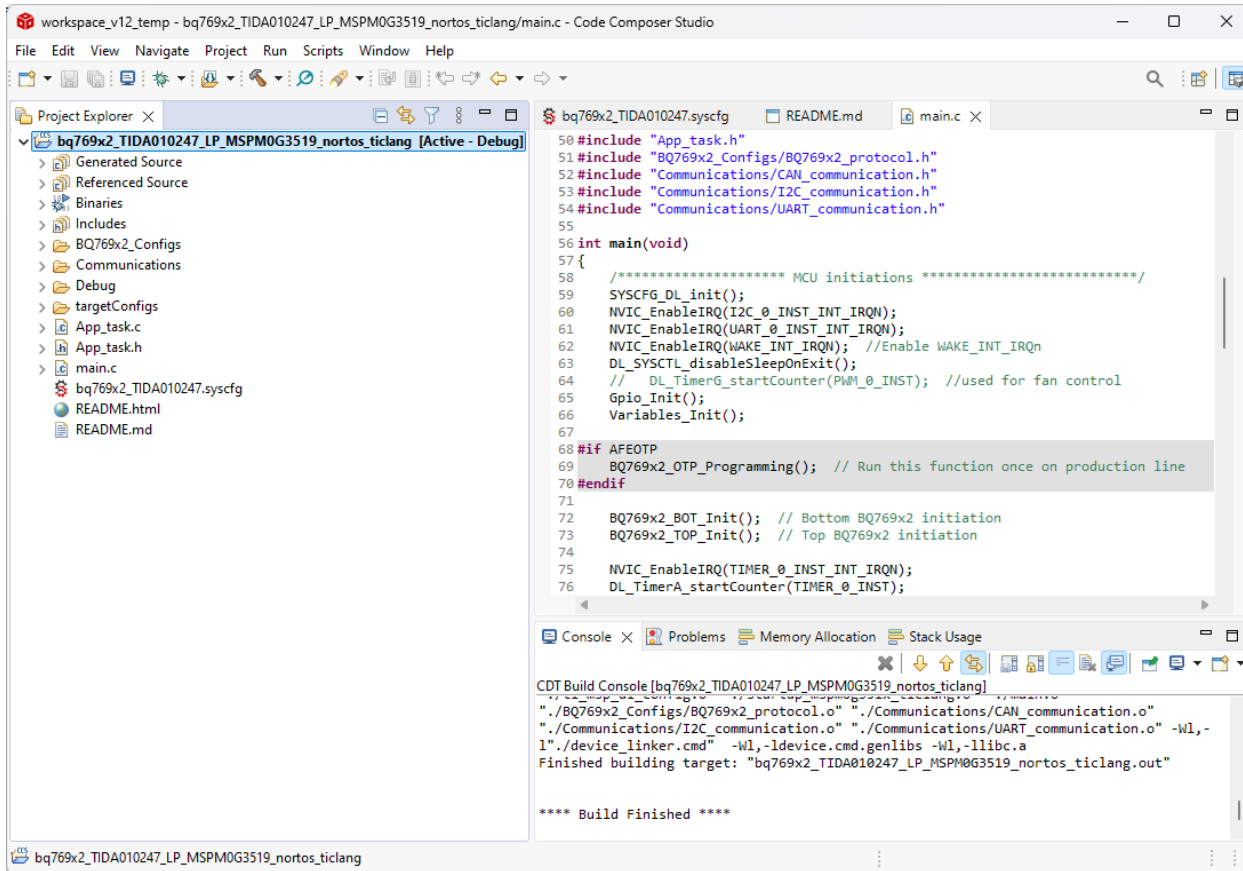

**Figure 3-2. Build the Project**

### 3.2.1.4 Download Image and Run

Click the *Run* → *Debug* menu options to download and debug software in CCS. [Figure 3-3](#) shows the Debug window. Click the *Run* button to start running the software. Basic functions are implemented in the `BMU_Normal_Mode();` function.

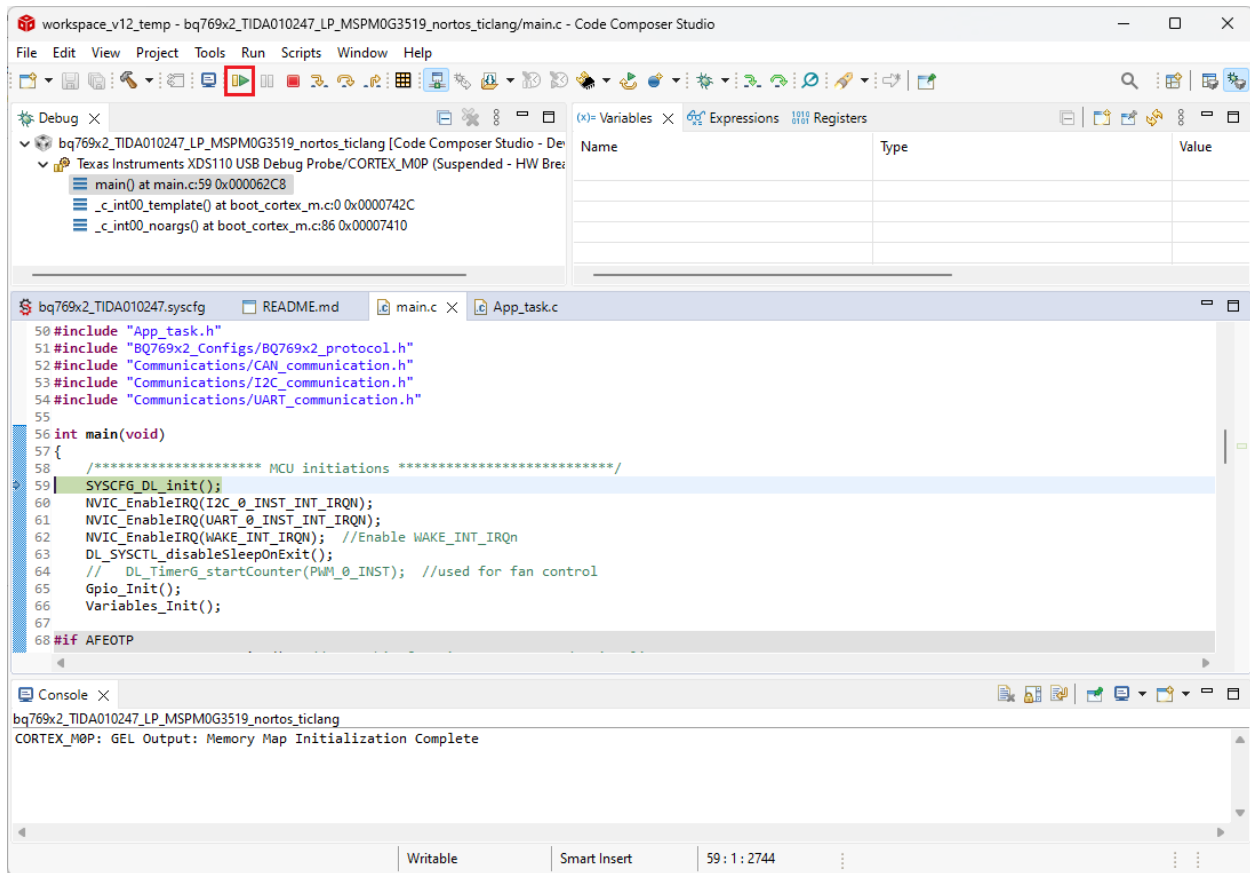

Figure 3-3. Debug the Project

### 3.2.2 Software Function List

This section introduces the software interface with two parts, [Driverlib Function List](#) and [Application Function List](#).

#### 3.2.2.1 Driverlib Function List

The Driverlib function is a low-level peripheral driver based on the TI driverlib.

##### ***CAN\_ID\_Init\_on\_Startup***

***Automatically initialize the CAN id after the system is powered on.***

##### **Syntax**

```
void CAN_ID_Init_on_Startup(void);
```

##### **Parameters**

Void.

##### **Return Value**

Void.

##### **Description**

When the system is powered on and the peripherals are initialized, the CAN peripherals do not work directly.

The following are the steps for automatic CAN id initialization:

1. Host(BCU) send wake up pattern to node #1 wake\_in pin.
2. Node#1 receive wake\_in IO high, and set ID command, data on CAN bus message, then sets CANID, belonging to Node#1.



**CAN\_ID\_Init\_on\_Startup** (continued)

**Automatically initialize the CAN id after the system is powered on.**

---

3. Node#1 send wake up pattern from wake\_out IO to wake up the Node#2, and send the set ID command with CANID+1 CAN message to Node#2.
4. Node#2 receive wake up pattern, and set ID command, data on CAN bus message, then sets CANID+1, belonging to Node#2.
5. Other nodes follow the same steps to complete the automatic CAN ID setting.

**CAN\_Write**

**Send the BQ devices data to CAN bus according to the parameters.**

---

**Syntax**

```
void CAN_Write(uint32_t CANid, uint8_t BQid, uint8_t cmd, uint32_t length, uint16_t *data);
```

**Parameters**

CANid	CAN message ID
BQid	BQ device ID
cmd	CAN message command
length	Length of data
data	Data address to be sent via CAN

**Return Value**

Void.

**Description**

This function send BQ device data to CAN bus.

Package the function parameters in sequence and pass them into the *CAN\_TxMsgSendPoll* function. The driverlib level CAN sending function *CAN\_TxMsgSendPoll* uses the CPU polling to send data.

**CANprocessCANRxMsg**

**Process the received CAN message according to the CAN message id and command.**

---

**Syntax**

```
void CANprocessCANRxMsg(void);
```

**Parameters**

Void.

**Return Value**

Void.

**Description**

1. Firstly, this API check the CAN receive message FIFO 0 new message flag: *MCAN\_IR\_RF0N\_MASK*.
2. If there is new message in CAN receive FIFO, then read the message to RAM, and write the *RxFIFOAck* to CAN.
3. Convert the CAN id to *uint32\_t* id format.
4. Process the CAN message depending on id and command by using a switch-case function.

**CANprocessCANRxMsg** (continued)

**Process the received CAN message according to the CAN message id and command.**

---

The demonstration code implements the CAN id automatic setting function at power-on initialization stage.

**I2C\_WriteReg**

**Send I2C data depending on the register address and data of the I2C peripheral device.**

---

**Syntax**

```
void I2C_WriteReg(uint8_t reg_addr, uint8_t *reg_data, uint8_t count);
```

**Parameters**

reg_addr	I2C peripheral register address of the device
*reg_data	pointer to the data to be sent through I2C
count	Length of reg_data

**Return Value**

Void.

**Description**

1. Copy reg\_addr to I2Ctxbuff[0].
2. Copy count of \*reg\_data to &I2Ctxbuff[1].
3. Fill I2C FIFO with I2Ctxbuff.
4. Waiting for I2C transfer finishing and fill FIFO again in I2C interrupt handler.
5. Flush the I2C TXFIFO before exit.

The user can change the I2C peripheral device address by modifying the global variable *I2C\_TARGET\_ADDRESS*.

**I2C\_ReadReg**

**Read the register address of the I2C peripheral device.**

---

**Syntax**

```
void I2C_ReadReg(uint8_t reg_addr, uint8_t *reg_data, uint8_t count);
```

**Parameters**

reg_addr	I2C peripheral register address of the device
*reg_data	pointer to the data to be read from I2C
count	Length of reg_data

**Return Value**

Void.

**Description**

This API start a I2C write first to send the I2C peripheral device register address to be read then start a I2C read operation.

1. Start I2C controller transfer with reg\_adre fill to TXFIFO and length set to 1.
2. Flush TXFIFO after I2C write operation.
3. Start I2C controller transfer to read data from I2C target, length set to count.
4. Waiting for RXFIFO data ready and read information to reg\_data, exit when count of data is read.

**I2C\_ReadReg** (continued)

---

**Read the register address of the I2C peripheral device.**

---

The user can change the I2C peripheral device address by modifying the global variable *I2C\_TARGET\_ADDRESS*.

**RS485\_Send**

---

**Send BQ device data to UART, RS-485 interface**

---

**Syntax**

```
void RS485_Send(uint8_t BQid, uint8_t cmd, uint16_t *data, uint32_t length);
```

**Parameters**

BQid	BQ device ID, indicates Top or Bottom AFE
cmd	Message command, indicates the type of data sent
data	Pointer to the data to be sent via UART, RS-485
length	Length of data

**Return Value**

Void.

**Description**

1. Enable RS485 transceiver TX mode.
2. Copy BQid, cmd and data to RS485\_data buffer.
3. Set RS485 structure variables, *RS485\_STATUS\_TX\_STARTED*.
4. Fill UART TXFIFO with *gRS485.txPacket*.
5. Enable UART, RS-485 TX interrupt.
6. Fill UART, RS-485 TXFIFO in interrupt.
7. Waiting for transmission done.
8. Set *gRS485.status* to *RS485\_STATUS\_IDLE*.

**RS485\_Receive**

---

**Read data from UART, RS-485 interface**

---

**Syntax**

```
void RS485_Receive(uint8_t *RS485_data, uint32_t RS485_count);
```

**Parameters**

RS485_data	Data buffer to save the RS485 data
RS485_count	The length of data to be received

**Return Value**

Void.

**Description**

1. Set *gRS485.status* to *RS485\_STATUS\_RX\_STARTED*.
2. Enable UART, RS-485 RX interrupt.
3. Waiting for receive done in interrupt.
4. Disable TX interrupt and reset *gRS485.status* to *RS485\_STATUS\_IDLE*.
5. Copy RS485 data to RS485\_data.

### 3.2.2.2 Application Function List

The application function is defined by the test requirements of this design.

#### *Temp\_Mux\_Polling*

***Update the temperature measurement value.***

---

#### Syntax

```
void Temp_Mux_Polling(void);
```

#### Parameters

Void.

#### Return Value

Void.

#### Description

This function is created for the thermistor multiplexer circuit. TMP\_MUX\_Enabled symbol must be set before using this function. This function needs to update the FULLSCAN flag of each AFE before reading the temperature measurement data. The FULLSCAN flags are updated by function BQ769x2\_ReadFULLSCAN() and must be ran in short interval such as 1ms. This design read FULLSCAN flag in main while() as an example. The temperature measurement data are read when FULLSCAN flag is set and then clear this flag by writing alarm status register. The data are read in mV so the voltage need be converted to temperature using the thermistor lookup table or polynomial calculation.

#### *BatteryDataUpdate\_32s*

***Update cell voltage, pack current, battery status and protection status.***

---

#### Syntax

```
void BatteryDataUpdate_32s(void);
```

#### Parameters

Void.

#### Return Value

Void.

#### Description

This function updates 32s cells voltage and pack current every 100ms. The battery status, protection status, and FET status are updated every 500ms. The 32s cell voltage are read by direct command in sequence. Changing the timer period changes the data update period.

---

#### **Note**

This design uses the same I2C peripheral so the data from bottom AFE and top AFE can not be read at same time.

---

#### *BQ769x2\_OTP\_Programming*

***OTP bottom AFE I2C address to 0x20 and REG1 to 3.3V.***

---

#### Syntax

```
void BQ769x2_OTP_Programming();
```

**BQ769x2\_OTP\_Programming** (continued)

***OTP bottom AFE I2C address to 0x20 and REG1 to 3.3V.***

---

<b>Parameters</b>	Void.
<b>Return Value</b>	Void.
<b>Description</b>	This function shows how to OTP BQ76972 to specific configurations. Before OTP, 10V–12V voltage must be applied to BQ76972 BAT pin. This function sets OTP_write_success_flag after successful OTP write. Also, the blue LED blinks to indicate the successful write.

***Check\_Signal\_Pattern***

***Check WAKEIN signal pattern.***

---

<b>Syntax</b>	bool check_signal_pattern();
<b>Parameters</b>	Void.
<b>Return Value</b>	Returns true on gWAKEINMCU with receiving correct wake signal as shown in <a href="#">Figure 2-9</a> . Returns false on gWAKEINMCU with wrong wake signal.
<b>Description</b>	This function checks the high-level and low-level voltage duration and returns a flag for CAN addressing function.

***BMU\_FET\_Test***

***Test the protection FETs turn-on and turn-off.***

---

<b>Syntax</b>	void BMU_FET_Test(void);
<b>Parameters</b>	Void.
<b>Return Value</b>	Void.
<b>Description</b>	This function is ran at GPIO interrupt and only for test purpose. Enable AFE_MOS_TEST before testing this function. An external control signal can be used to trigger GPIO interrupt to test host-controlled MOSFET ON or OFF operations. PB.23 is used as example and the rising-edge is the trigger source.

**3.2.3 Software Workflow**

A software example is provided to show how to use the design in an ESS application. [Figure 3-4](#) shows the software flow chart. Before using this software, the bottom AFE must be programmed to a different I2C address as the OTP example in this flow chart.

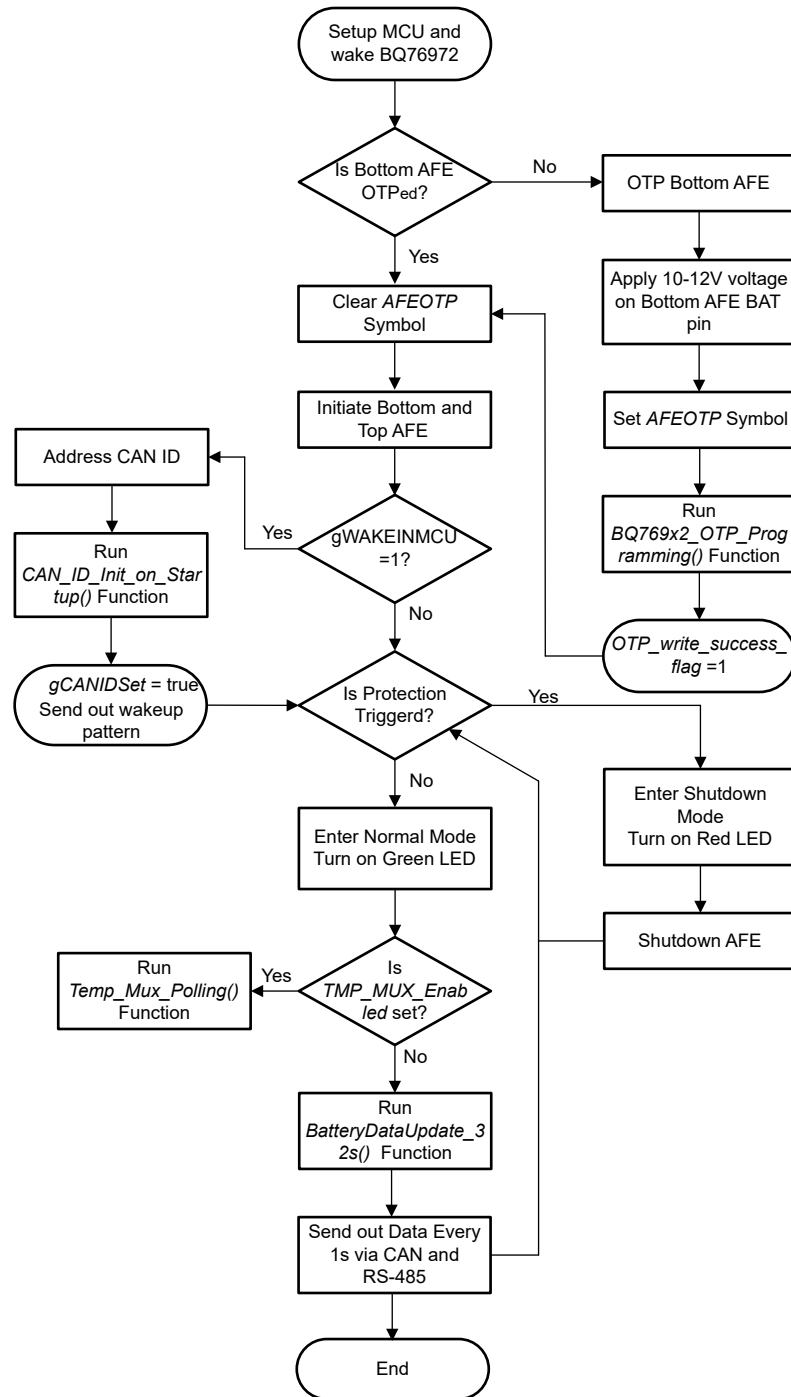

Figure 3-4. Software Flow Chart

### 3.3 Test Setup

Use the following procedures before running this design board. The design was constructed with 32s pack configurations. The board was tested using DC source and 2700 $\mu$ F electrolytic capacitor in parallel to simulate the total pack. Twenty 200 $\Omega$  resistors in series are used to divide the pack voltage and simulate 32s battery cells.

- DC source 1 configurations: 96V, 3A
- DC source 2 configurations: two channel 48V, 0.5A
- Electronic load configurations: 80V constant voltage (CV) mode

Figure 3-5 shows the charge process setup example.

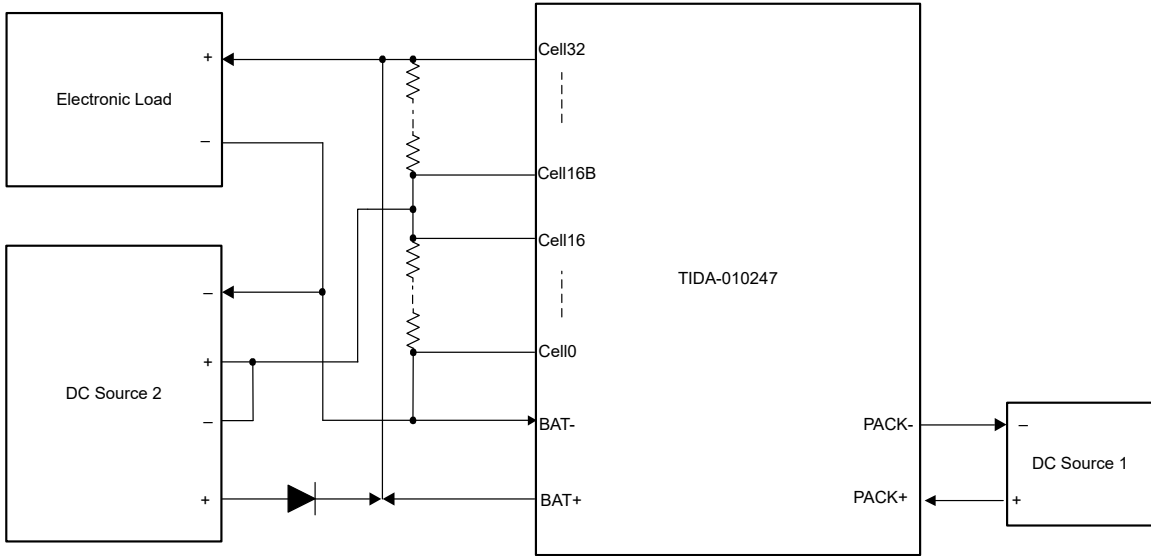

**Figure 3-5. Charge Setup**

Figure 3-6 shows the discharge process setup example using the following conditions.

- DC source configurations: 96V, 100A
- Electronic load configurations: constant current (CC) mode

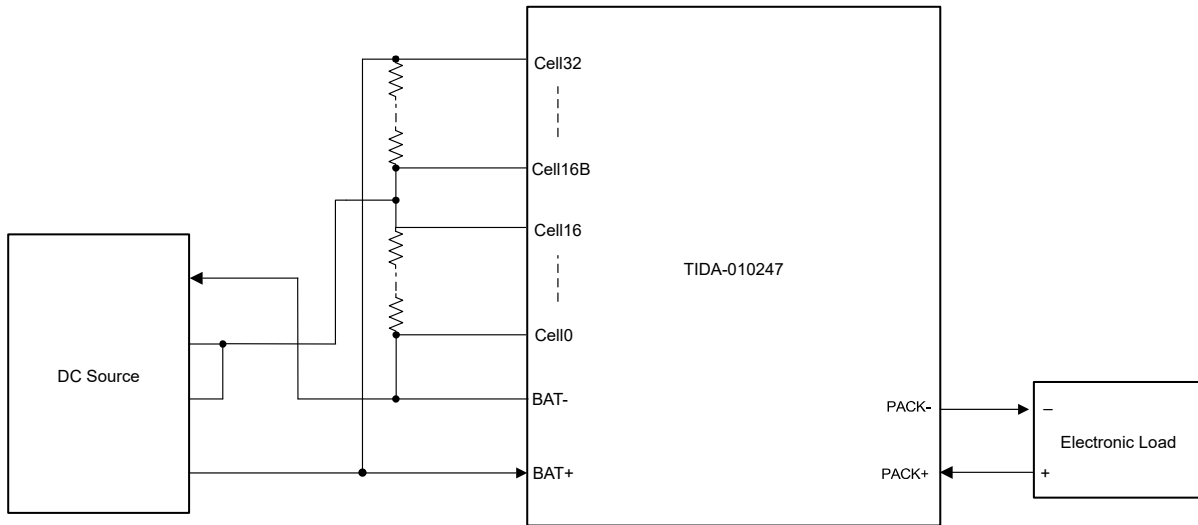

**Figure 3-6. Discharge Setup**

## 3.4 Test Results

### 3.4.1 Cell Voltage Accuracy

This design simply adjusts the fixed offset by subtracting fixed per-cell offset values from the reported cell measurement results. This design does not do cell offset calibration to further improve the cell voltage accuracy since the BQ76972 already achieves  $\pm 1.8\text{mV}$  accuracy at  $25^\circ\text{C}$  and  $\pm 4.5\text{mV}$  accuracy from  $-40^\circ\text{C}$  to  $85^\circ\text{C}$  when using the LFP battery cell. The cell voltage accuracy is exactly the same with the BQ76972. See also the [BQ76972 3-Series to 16-Series High Accuracy Battery Monitor and Protector for Li-Ion, Li-Polymer, and LiFePO4 Battery Packs](#) data sheet.

### 3.4.2 Pack Current Accuracy

This design uses one  $0.3\text{m}\Omega$ ,  $15\text{W}$ ,  $25\text{PPM}$  shunt resistor to measure pack current. The board offset is calibrated using the guidance of the *calibration* section of the [BQ769x2 Calibration and OTP Programming Guide](#). Then current gain is calibrated with  $6\text{A}$  discharging current and also following the guidance of this application note. Write the *board offset and current gain* values with one-time-programmable (OTP) to the bottom BQ76972; otherwise, the MCU has to store such data and write to the bottom BQ76972 every time the device wakes up from shutdown mode. [Figure 3-7](#) shows the pack current accuracy data under room temperature. The maximum current error is below  $20\text{mA}$  when the discharging current is below  $5\text{A}$  and  $0.2\%$  when the discharging current is above  $5\text{A}$ .

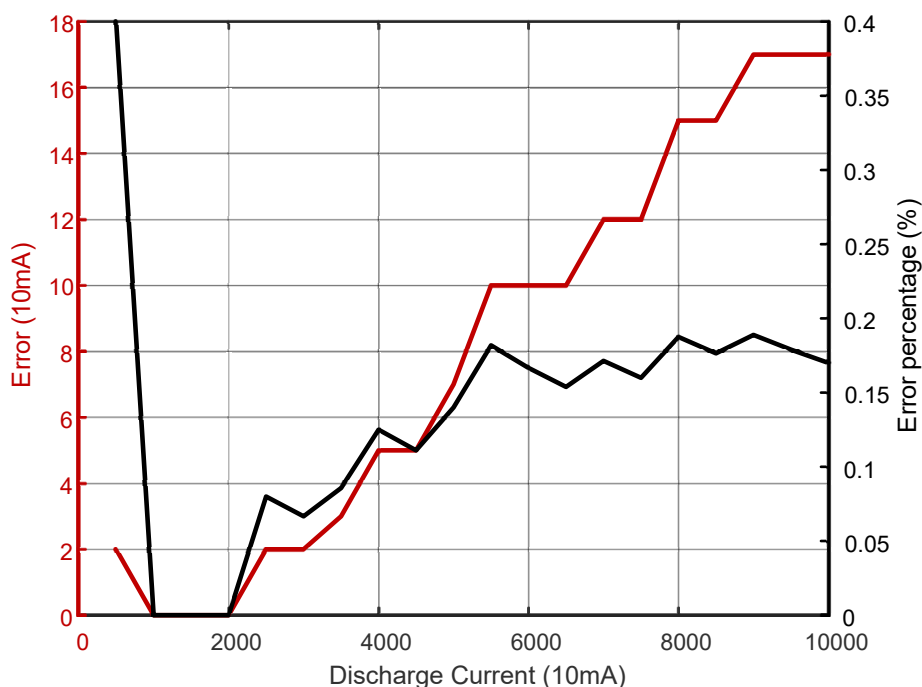

**Figure 3-7. Pack Current Accuracy**

### 3.4.3 Auxiliary Power and System Current Consumption

Due to the auxiliary power strategy, this design has very low current consumption in shutdown mode. Because of the stacked architecture, the total system consumption is the maximum value of current out of the top stack and current back to the battery negative port. Current value can be measured from the voltage across a  $10\Omega$  resistor.

Furthermore, the current consumption gaps between two stacked groups are optimized in this design to avoid further cell balancing between groups. The current consumption gaps can be calculated by subtracting  $I_{\text{GND}}$  from  $I_{\text{cell}32}$ . [Figure 3-8](#) shows the setup to test current consumption and [Table 3-3](#) shows the test results of the average system current consumption and average group imbalance current.



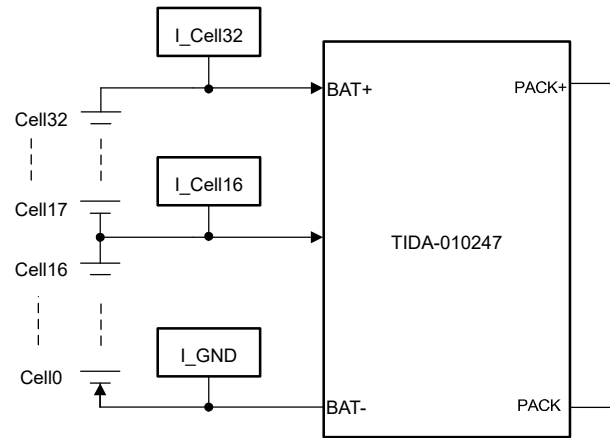

Figure 3-8. Current Consumptions Test Setup

Table 3-3. Current Consumption

DESCRIPTION		I <sub>cell32</sub>	I <sub>cell16</sub>	I <sub>GND</sub>	CURRENT GAP (μA)	TOTAL CURRENT (μA)
Normal Mode (MOSFET off)	Current (μA)	4550	550	4565	15	4565
Normal Mode (MOSFET on)	Current (μA)	4504	550	4484	20	4504
Ship Mode	Current (μA)	7	0	7	0	7

The data is tested on the power rail configuration for low-voltage ESS because another configuration is powered by external 24V rather than the battery. The [INA229\\_239EVM](#) and a 10Ω resistor is used to test the current. The total current consumption is less than 4.6mA in normal mode with both charge and discharge MOSFETs either on or off. The imbalance between groups is less than 20μA. The ship mode current consumption is less than 10μA.

Figure 3-9 shows the test results for the auxiliary power start-up.

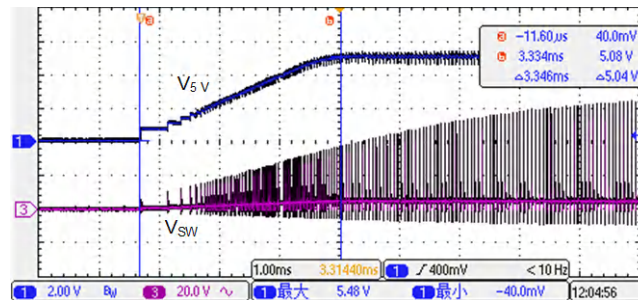

Figure 3-9. DC/DC Start-Up

This design also considers the faults of DC/DC output short circuited. Figure 3-10 shows the DC/DC short-circuit test results. DC/DC is disabled by the MCU when output is short circuited to prevent thermal issues.

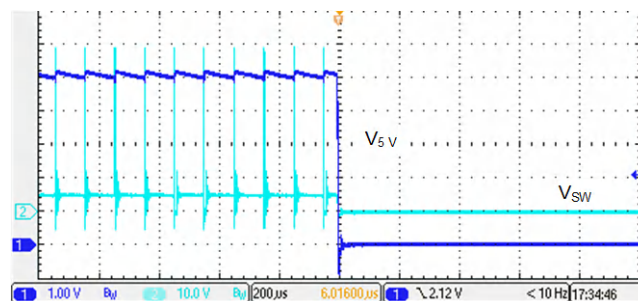

Figure 3-10. DC/DC Output Short Circuit

### 3.4.4 Protection

The design integrates a full set of battery cell protections, including: cell overvoltage, cell undervoltage, two levels of overcurrent discharge, overcurrent charge, discharge short circuit, and overtemperature and undertemperature protections. Furthermore, this design also monitors lots of system-level faults, including: cell open wire, host watch dog, charge and discharge MOSFETs faults, MOSFETs overtemperature, and so on. Some of the protections were tested in a TI lab.

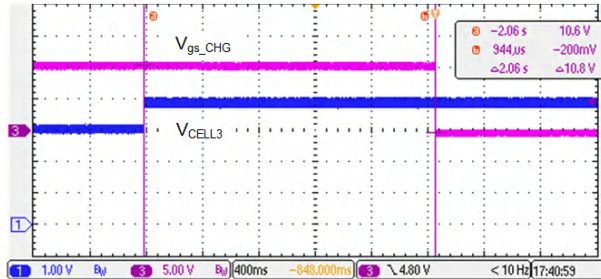

Figure 3-11. Cell Overvoltage Protection

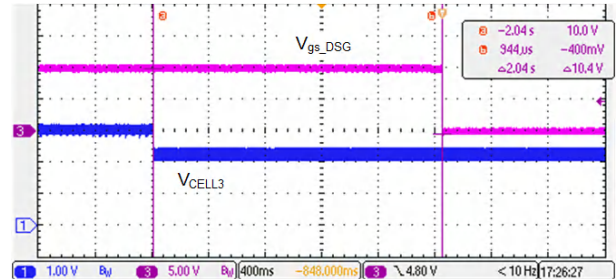

Figure 3-12. Cell Undervoltage Protection

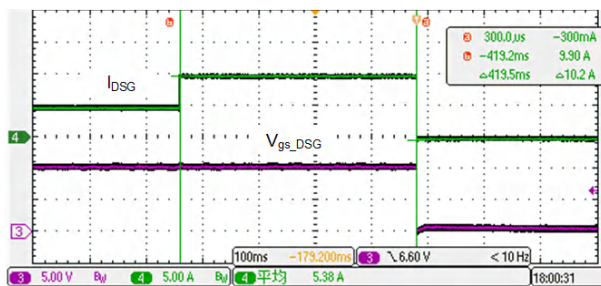

Figure 3-13. Overcurrent Discharge Protection

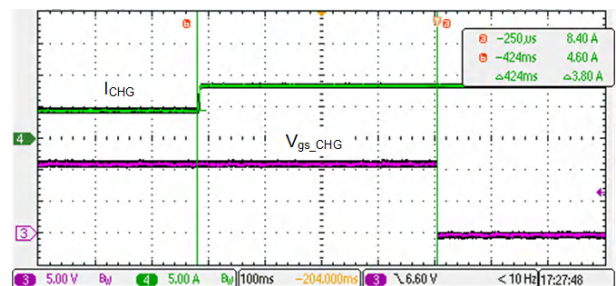

Figure 3-14. Overcurrent Charge Protection

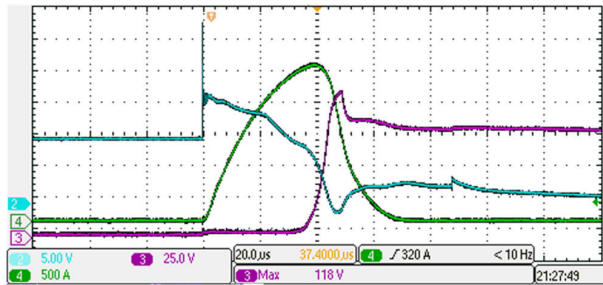

Figure 3-15. Short-Circuit Discharge Protection

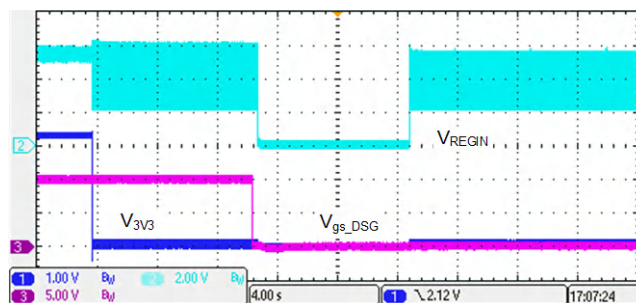
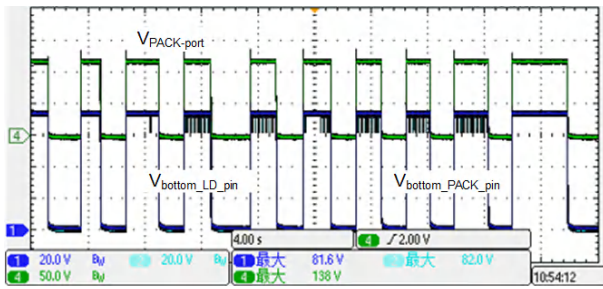
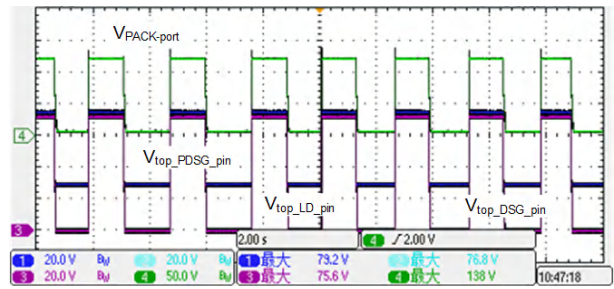

Figure 3-16. 3.3V Short and HWD Protections

When 3.3V is shorted, the MCU is powered off and both BQ76972 devices detect host watchdog (HWD) protection after some delay. Since TIDA-010247 configures MCU wake up from entering lower power mode (no communication with the BQ76972 to save power) every 5s, observe a range of 5s to 10s delay with 10s HWD delay configurations.



**Figure 3-17. 120V On-PACK Port – Bottom AFE Maximum Voltage**

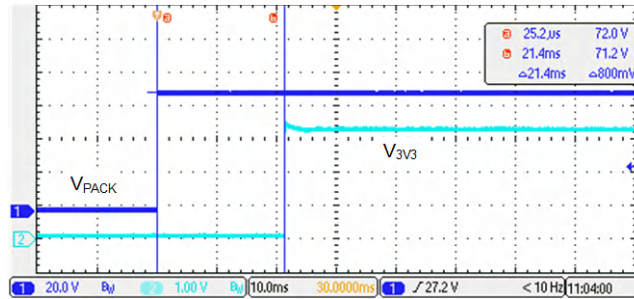

**Figure 3-18. 120V On-PACK Port – Top AFE Maximum Voltage**

The 120V on PACK port test is carried out with both CHG and DSG MOSFET off.

### 3.4.5 Working Modes Transition

This design has three working modes: normal mode, standby mode, and ship mode. When the pack is charging or discharging, the pack is in normal mode. Standby mode is when there is no charging nor discharging, the pack is waiting for a charger or load attachment. Shutdown mode is a very low current consumption mode which saves energy and helps to avoid battery over discharge when the pack or cell voltage is low. Figure 3-19 shows different working mode transitions.



**Figure 3-19. Ship Mode to Normal Mode**

When TIDA-010247 is in ship mode and both BQ76972 devices are in shutdown mode, the bottom BQ76972 detects the charger attached on the PACK side and wakes up to normal mode, enabling REG1 or REG2 to power on the MCU.

### 3.4.6 Thermistor Multiplexer

Figure 3-20 shows the thermistor multiplexer control signals A and B repeat in sequence 00-10-01-11 automatically. This design takes 320ms to measure all 17 thermistors temperature.

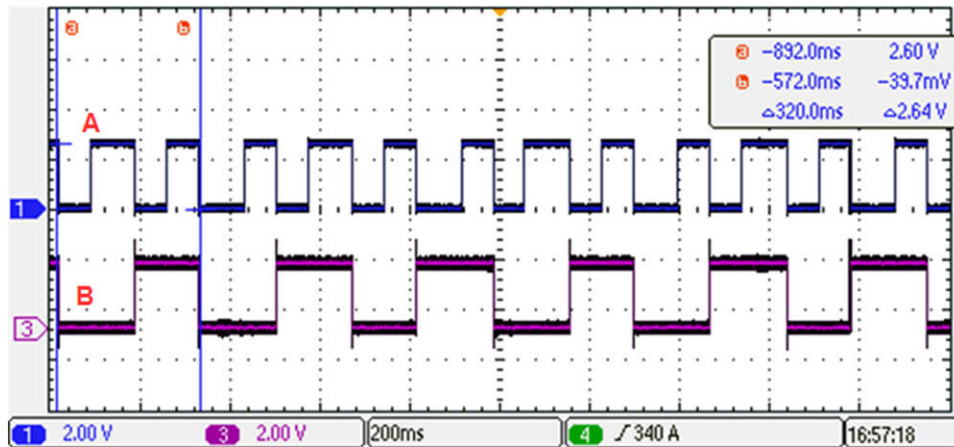

Figure 3-20. Thermistor Multiplexer Control Signal

High accuracy and precision temperature measurements can be easily achieved at low cost with TMP6x linear thermistors using the steps outlined in the [How to Achieve  \$\pm 1^\circ\text{C}\$  Accuracy or Better Across Temperature With Low-Cost TMP6x Linear Thermistors](#) application note.

Figure 3-21 shows the temperature measurement accuracy across  $20^\circ\text{C}$  to  $125^\circ\text{C}$ . The test is done by soaking the thermistor in an oil bath and bringing the BMU to room temperature. The temperature measurement error is below  $1^\circ\text{C}$  when the temperature is above  $-20^\circ\text{C}$  and  $2.5^\circ\text{C}$  when the temperature is below  $-20^\circ\text{C}$ .

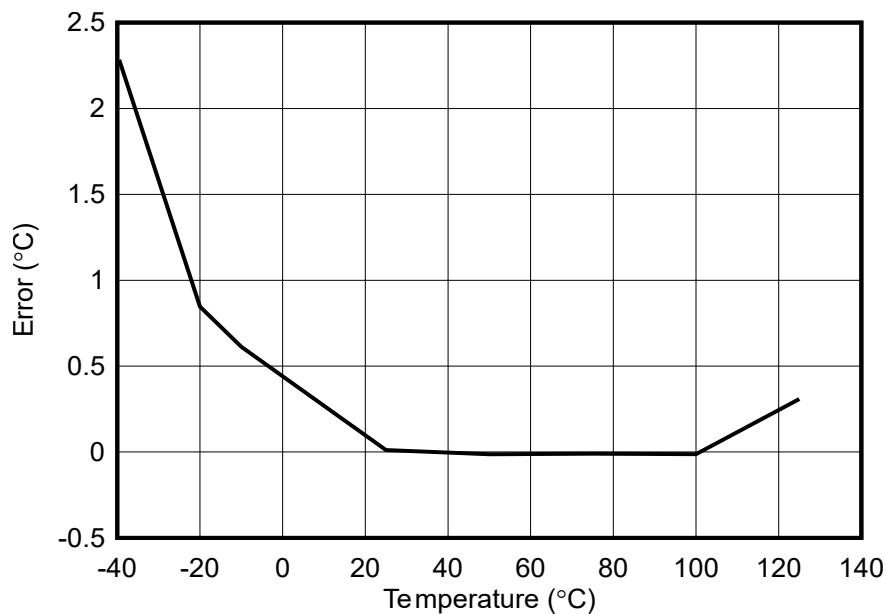

Figure 3-21. Temperature Accuracy

### 3.4.7 ESD Performance

The ESD performance of this design was tested in a third-party certification lab per IEC 61000-4-2 with a real 32s battery pack attached. [Table 3-4](#) lists the test results from the ESD contact discharge testing.

**Table 3-4. ESD - Contact Discharge**

VOLTAGE	APPLIED TERMINAL										
	PACK+	PACK-	CAN0H	CAN0L	CAN1H	CAN1L	RS-485A	RS-485B	WakeIn	WakeOut	Fan Control
2kV	PASS	PASS	PASS	PASS	PASS	PASS	PASS	PASS	PASS	PASS	PASS
-2kV	PASS	PASS	PASS	PASS	PASS	PASS	PASS	PASS	PASS	PASS	PASS
4kV	PASS	PASS	PASS	PASS	PASS	PASS	PASS	PASS	PASS	PASS	PASS
-4kV	PASS	PASS	PASS	PASS	PASS	PASS	PASS	PASS	PASS	PASS	PASS
8kV	PASS	PASS	PASS	PASS	PASS	PASS	PASS	PASS	PASS	PASS	PASS
-8kV	PASS	PASS	PASS	PASS	PASS	PASS	PASS	PASS	PASS	PASS	PASS

### 3.4.8 Surge Immunity

This design demonstrates immunity to surges in accordance with the test procedure specified in IEC61000-4-5. The tests are conducted on the DC power ports and the communication ports using the following specified test levels:

- For DC power ports — PACK+ and PACK-: test level 4, ±2kV line-to-line, and ±4kV line-to-ground
- For communication ports — CAN and RS-485: test level 3, ±1kV line-to-line, and ±2kV line-to-ground

The device was tested in a third-party certification lab with a real 32s battery pack attached. [Table 3-5](#) lists the test results.

**Table 3-5. Surge Performance**

Open-Circuit Test Voltage		APPLIED TERMINAL									
		PACK+	PACK-	CAN0H	CAN0L	CAN1H	CAN1L	RS-485A	RS-485B		
Line-to-Line	1kv	N/A		PASS	PASS	PASS	PASS	PASS	PASS		
	-1kv	N/A		PASS	PASS	PASS	PASS	PASS	PASS		
	2kV	PASS	PASS	N/A							
	-2kV	PASS	PASS	N/A							
Line-to-ground	2kV	N/A		PASS	PASS	PASS	PASS	PASS	PASS		
	-2kv	N/A		PASS	PASS	PASS	PASS	PASS	PASS		
	4kV	PASS	PASS	N/A							
	-4kV	PASS	PASS	N/A							

## 4 Design and Documentation Support

### 4.1 Design Files

#### 4.1.1 Schematics

To download the schematics, see the design files at [TIDA-010247](#).

#### 4.1.2 BOM

To download the bill of materials (BOM), see the design files at [TIDA-010247](#).

### 4.2 Tools and Software

#### Tools

<a href="#">EV2400</a>	USB-based PC interface board for battery fuel (gas) gauge evaluation module
<a href="#">LM5169 Quick Start Calculator</a>	LM5163 and LM5164 converter quickstart design tool
<a href="#">BQ769X2-THERMISTOR-COEFF-CALCULATOR</a>	BQ76952, BQ76942 thermistor temperature optimizer - calculate the thermistors coefficients for T range
<a href="#">INA229_239EVM</a>	INA229 and INA239 evaluation module

#### Software

<a href="#">BQSTUDIO</a>	Battery Management Studio (bqStudio) Software
<a href="#">CCSTUDIO</a>	Code Composer Studio™ integrated development environment (IDE)

### 4.3 Documentation Support

1. Texas Instruments, [BQ76972 3-Series to 16-Series High Accuracy Battery Monitor and Protector for Li-Ion, Li-Polymer, and LiFePO4 Battery Packs Data Sheet](#)
2. Texas Instruments, [BQ769x2 Calibration and OTP Programming Guide](#)
3. Texas Instruments, [How to Stack Battery Monitors for High-cell-count Industrial Applications](#) E2E™ forum
4. Texas Instruments, [Using DC/DC Buck Converters With Ultra-Low Quiescent Current for Industrial Battery-Pack Applications Application Brief](#)
5. Texas Instruments, [How to Achieve ±1°C Accuracy or Better Across Temperature With Low-Cost TMP6x Linear Thermistors Application Note](#)

### 4.4 Support Resources

[TI E2E™ support forums](#) are an engineer's go-to source for fast, verified answers and design help — straight from the experts. Search existing answers or ask your own question to get the quick design help you need.

Linked content is provided "AS IS" by the respective contributors. They do not constitute TI specifications and do not necessarily reflect TI's views; see TI's [Terms of Use](#).

### 4.5 Trademarks

TI E2E™, Code Composer Studio™, and E2E™ are trademarks of Texas Instruments. Arm®, Cortex®, and Keil® are registered trademarks of Arm Limited. All trademarks are the property of their respective owners.

## 5 About the Author

**KIAN LIN**, system engineer from the SEM Industrial Energy Infrastructure team, focuses on battery pack and energy storage system applications to address industrial battery pack design challenges.

## 6 Revision History

NOTE: Page numbers for previous revisions may differ from page numbers in the current version.

---

### Changes from Revision A (December 2024) to Revision B (July 2025) Page

- Changed x-axis label in [Figure 3-7](#) from mA to 10mA.....24
- 

### Changes from Revision \* (December 2022) to Revision A (December 2024) Page

- This reference design is refreshed with the latest battery monitor device BQ76972 and microcontroller MSPM0G3519. This design also adds a CAN interface for BMU stacking high-voltage (up to 1500V) energy storage station applications..... 1
-

## IMPORTANT NOTICE AND DISCLAIMER

TI PROVIDES TECHNICAL AND RELIABILITY DATA (INCLUDING DATA SHEETS), DESIGN RESOURCES (INCLUDING REFERENCE DESIGNS), APPLICATION OR OTHER DESIGN ADVICE, WEB TOOLS, SAFETY INFORMATION, AND OTHER RESOURCES "AS IS" AND WITH ALL FAULTS, AND DISCLAIMS ALL WARRANTIES, EXPRESS AND IMPLIED, INCLUDING WITHOUT LIMITATION ANY IMPLIED WARRANTIES OF MERCHANTABILITY, FITNESS FOR A PARTICULAR PURPOSE OR NON-INFRINGEMENT OF THIRD PARTY INTELLECTUAL PROPERTY RIGHTS.

These resources are intended for skilled developers designing with TI products. You are solely responsible for (1) selecting the appropriate TI products for your application, (2) designing, validating and testing your application, and (3) ensuring your application meets applicable standards, and any other safety, security, regulatory or other requirements.

These resources are subject to change without notice. TI grants you permission to use these resources only for development of an application that uses the TI products described in the resource. Other reproduction and display of these resources is prohibited. No license is granted to any other TI intellectual property right or to any third party intellectual property right. TI disclaims responsibility for, and you will fully indemnify TI and its representatives against, any claims, damages, costs, losses, and liabilities arising out of your use of these resources.

TI's products are provided subject to [TI's Terms of Sale](#) or other applicable terms available either on [ti.com](https://www.ti.com) or provided in conjunction with such TI products. TI's provision of these resources does not expand or otherwise alter TI's applicable warranties or warranty disclaimers for TI products.

TI objects to and rejects any additional or different terms you may have proposed.

Mailing Address: Texas Instruments, Post Office Box 655303, Dallas, Texas 75265

Copyright © 2025, Texas Instruments Incorporated