

# LMR614x0-Q1

## Functional Safety FIT Rate, FMD and Pin FMA

---



### Table of Contents

1 Overview.....	2
2 Functional Safety Failure In Time (FIT) Rates.....	3
3 Failure Mode Distribution (FMD).....	4
4 Pin Failure Mode Analysis (Pin FMA).....	5
5 Revision History.....	7

### Trademarks

All trademarks are the property of their respective owners.

## 1 Overview

This document contains information for the LMR61430-Q1 and LMR61440-Q1 (RAK (WQFN-HR, 9) package) to aid in a functional safety system design. Information provided are:

- Functional safety failure in time (FIT) rates of the semiconductor component estimated by the application of industry reliability standards
- Component failure modes and distribution (FMD) based on the primary function of the device
- Pin failure mode analysis (pin FMA)

Figure 1-1 shows the device functional block diagram for reference.

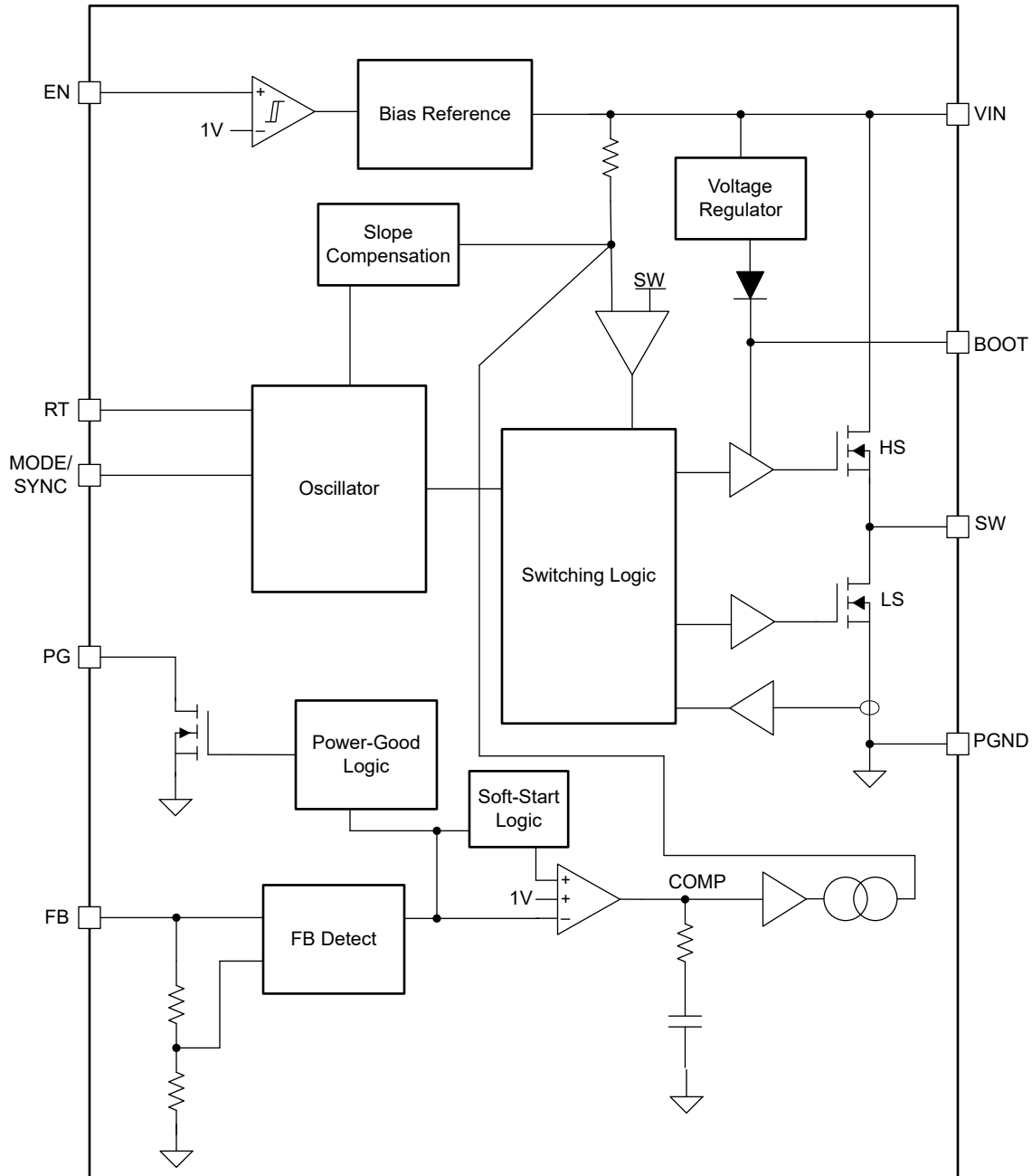

**Figure 1-1. Functional Block Diagram**

The LMR61430-Q1 and LMR61440-Q1 were developed using a quality-managed development process, but were not developed in accordance with the IEC 61508 or ISO 26262 standards.

## 2 Functional Safety Failure In Time (FIT) Rates

This section provides functional safety failure in time (FIT) rates for the LMR61430-Q1 and LMR61440-Q1 based on two different industry-wide used reliability standards:

- [Table 2-1](#) provides FIT rates based on IEC TR 62380 / ISO 26262 part 11
- [Table 2-2](#) provides FIT rates based on the Siemens Norm SN 29500-2

**Table 2-1. Component Failure Rates per IEC TR 62380 / ISO 26262 Part 11**

FIT IEC TR 62380 / ISO 26262	FIT (Failures Per 10 <sup>9</sup> Hours)
Total component FIT rate	10
Die FIT rate	5
Package FIT rate	5

The failure rate and mission profile information in [Table 2-1](#) comes from the reliability data handbook IEC TR 62380 / ISO 26262 part 11:

- Mission profile: Motor control from table 11 or figure 16
- Power dissipation: 640mW
- Climate type: World-wide table 8 or figure 13
- Package factor (lambda 3): Table 17b or figure 15
- Substrate material: FR4
- EOS FIT rate assumed: 0 FIT

**Table 2-2. Component Failure Rates per Siemens Norm SN 29500-2**

Table	Category	Reference FIT Rate	Reference Virtual T <sub>J</sub>
5	CMOS, BICMOS ASICs analog and mixed ≤50V supply	25 FIT	55°C

The reference FIT rate and reference virtual T<sub>J</sub> (junction temperature) in [Table 2-2](#) come from the Siemens Norm SN 29500-2 tables 1 through 5. Failure rates under operating conditions are calculated from the reference failure rate and virtual junction temperature using conversion information in SN 29500-2 section 4.

### 3 Failure Mode Distribution (FMD)

The failure mode distribution estimation for the LMR61430-Q1 and LMR61440-Q1 in [Table 3-1](#) comes from the combination of common failure modes listed in standards such as IEC 61508 and ISO 26262, the ratio of sub-circuit function size and complexity, and from best engineering judgment.

The failure modes listed in this section reflect random failure events and do not include failures resulting from misuse or overstress.

**Table 3-1. Die Failure Modes and Distribution**

Die Failure Modes	Failure Mode Distribution (%)
No output voltage	60
Output voltage not in specification – voltage or timing	30
Gate driver stuck on	5
Power good false trip or failure to trip	5

## 4 Pin Failure Mode Analysis (Pin FMA)

This section provides a failure mode analysis (FMA) for the pins of the LMR61430-Q1 and LMR61440-Q1. The failure modes covered in this document include the typical pin-by-pin failure scenarios:

- Pin short-circuited to ground (see [Table 4-2](#))
- Pin open-circuited (see [Table 4-3](#))
- Pin short-circuited to an adjacent pin (see [Table 4-4](#))
- Pin short-circuited to supply (see [Table 4-5](#))

[Table 4-2](#) through [Table 4-5](#) also indicate how these pin conditions can affect the device as per the failure effects classification in [Table 4-1](#).

**Table 4-1. TI Classification of Failure Effects**

Class	Failure Effects
A	Potential device damage that affects functionality.
B	No device damage, but loss of functionality.
C	No device damage, but performance degradation.
D	No device damage, no impact to functionality or performance.

[Figure 4-1](#) shows the LMR61430-Q1 and LMR61440-Q1 pin diagram. For a detailed description of the device pins, see the *Pin Configuration and Functions* section in the [LMR61430-Q1](#) and [LMR61440-Q1](#) datasheet.

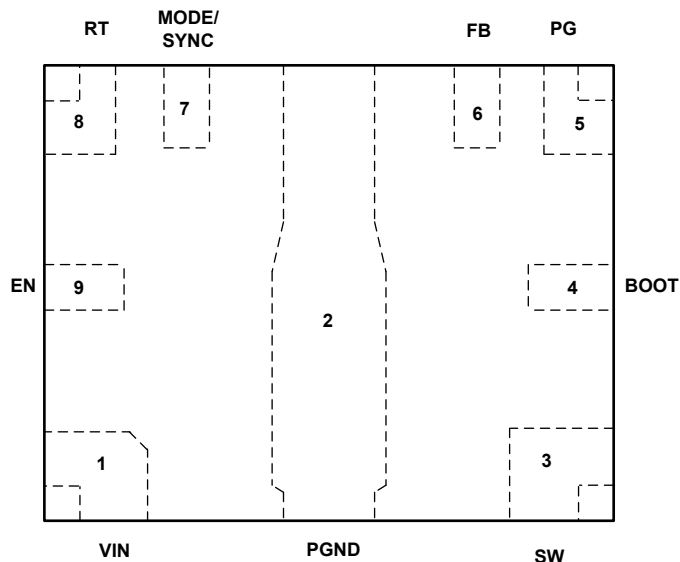

**Figure 4-1. Pin Diagram**

Following are the assumptions of use and the device configuration assumed for the pin FMA in this section:

- The application circuit is used according to the LMR61430-Q1 and LMR61440-Q1 datasheets.

**Table 4-2. Pin FMA for Device Pins Short-Circuited to Ground**

Pin Name	Pin No.	Description of Potential Failure Effects	Failure Effect Class
VIN	1	$V_{OUT} = 0V$ .	B
PGND	2	$V_{OUT}$ is normal.	D
SW	3	Damage to high-side FET.	A
BOOT	4	$V_{OUT} = 0V$ . High-side FET does not turn on.	B
PG	5	When not in use, this pin can be left grounded (PG is not a valid signal and $V_{OUT}$ is normal).	D
FB	6	When in adjustable output mode, $V_{OUT}$ approaches VIN. When in fixed output mode, $V_{OUT} = 0V$ .	B
MODE/SYNC	7	Device switches in AUTO mode. $V_{OUT}$ is normal.	D
RT	8	Device stops switching until short to GND is removed.	B
EN	9	$V_{OUT} = 0V$ . Enable is below the $V_{EN-TH}$ and functionality is halted.	D

**Table 4-3. Pin FMA for Device Pins Open-Circuited**

Pin Name	Pin No.	Description of Potential Failure Effects	Failure Effect Class
VIN	1	$V_{OUT} = 0V$ .	B
PGND	2	$V_{OUT}$ can be abnormal.	C
SW	3	$V_{OUT} = 0V$ .	B
BOOT	4	$V_{OUT} = 0V$ . High-side FET does not turn on.	B
PG	5	When not in use, this pin can be left open (PGOOD is not a valid signal and $V_{OUT}$ is normal).	D
FB	6	$V_{OUT}$ approaches VIN.	C
MODE/SYNC	7	Mode of operation can toggle between AUTO and FPWM.	C
RT	8	Internal clock does not operate properly and the part does not switch.	B
EN	9	Pin cannot be left floating. Device potentially does not enable.	B

**Table 4-4. Pin FMA for Device Pins Short-Circuited to Adjacent Pin**

Pin Name	Pin No.	Shorted to	Description of Potential Failure Effects	Failure Effect Class
VIN	1	PGND	$V_{OUT} = 0V$ .	B
PGND	2	SW	Damage to high-side FET.	A
SW	3	BOOT	$V_{OUT} = 0V$ , high-side FET does not turn on and there is not $C_{BOOT}$ .	B
BOOT	4	PG	PG damage occurs if BOOT voltage is greater than PG absolute maximum voltage.	B
PG	5	FB	In fixed output mode, $V_{OUT} = 0V$ . In adjustable mode, if a short happens before soft state is complete, output voltage approaches input voltage supply.	B
FB	6	PGND	In fixed output mode, $V_{OUT} = 0V$ . In adjustable output mode, output voltage approaches the input voltage supply.	B
MODE/SYNC	7	RT	Device operates in FPWM.	D
RT	8	EN	Internal clock does not switch at the correct frequency.	C
EN	9	VIN	Device is enabled once the voltage between VIN and PGND is greater than $V_{INUVLO(R)}$ .	D

**Table 4-5. Pin FMA for Device Pins Short-Circuited to Supply**

Pin Name	Pin No.	Description of Potential Failure Effects	Failure Effect Class
VIN	1	$V_{OUT}$ is normal.	D
PGND	2	$V_{OUT} = 0V$ .	B
SW	3	Damage to low-side FET.	A
BOOT	4	Damage occurs to BOOT ESD.	A
PG	5	If supply voltage is greater than 20V, damage occurs to PGOOD pin.	A
FB	6	If supply voltage is greater than 16V, damage occurs.	A
MODE/SYNC	7	Device operates in FPWM.	D
RT	8	Internal clock does not switch at the correct frequency.	C
EN	9	$V_{OUT}$ is normal.	D

## 5 Revision History

NOTE: Page numbers for previous revisions may differ from page numbers in the current version.

DATE	REVISION	NOTES
June 2026	*	Initial Release

## IMPORTANT NOTICE AND DISCLAIMER

TI PROVIDES TECHNICAL AND RELIABILITY DATA (INCLUDING DATASHEETS), DESIGN RESOURCES (INCLUDING REFERENCE DESIGNS), APPLICATION OR OTHER DESIGN ADVICE, WEB TOOLS, SAFETY INFORMATION, AND OTHER RESOURCES "AS IS" AND WITH ALL FAULTS, AND DISCLAIMS ALL WARRANTIES, EXPRESS AND IMPLIED, INCLUDING WITHOUT LIMITATION ANY IMPLIED WARRANTIES OF MERCHANTABILITY, FITNESS FOR A PARTICULAR PURPOSE OR NON-INFRINGEMENT OF THIRD PARTY INTELLECTUAL PROPERTY RIGHTS.

These resources are intended for skilled developers designing with TI products. You are solely responsible for (1) selecting the appropriate TI products for your application, (2) designing, validating and testing your application, and (3) ensuring your application meets applicable standards, and any other safety, security, regulatory or other requirements.

These resources are subject to change without notice. TI grants you permission to use these resources only for development of an application that uses the TI products described in the resource. Other reproduction and display of these resources is prohibited. No license is granted to any other TI intellectual property right or to any third party intellectual property right. TI disclaims responsibility for, and you fully indemnify TI and its representatives against any claims, damages, costs, losses, and liabilities arising out of your use of these resources.

TI's products are provided subject to [TI's Terms of Sale](#), [TI's General Quality Guidelines](#), or other applicable terms available either on [ti.com](http://ti.com) or provided in conjunction with such TI products. TI's provision of these resources does not expand or otherwise alter TI's applicable warranties or warranty disclaimers for TI products. Unless TI explicitly designates a product as custom or customer-specified, TI products are standard, catalog, general purpose devices.

TI objects to and rejects any additional or different terms you may propose.

Copyright © 2026, Texas Instruments Incorporated

Last updated 10/2025