



**Table of Contents**

<b>1 Overview</b> .....	<b>2</b>
<b>2 Functional Safety Failure In Time (FIT) Rates</b> .....	<b>3</b>
2.1 TSSOP Package.....	3
<b>3 Failure Mode Distribution (FMD)</b> .....	<b>4</b>
<b>4 Pin Failure Mode Analysis (Pin FMA)</b> .....	<b>5</b>
4.1 TSSOP Package.....	5
<b>5 Revision History</b> .....	<b>17</b>

**Trademarks**

All trademarks are the property of their respective owners.

# 1 Overview

This document contains information for the **TXE8148** (TSSOP) to aid in a functional safety system design. Information provided are:

- Functional safety failure in time (FIT) rates of the semiconductor component estimated by the application of industry reliability standards
- Component failure modes and distribution (FMD) based on the primary function of the device
- Pin failure mode analysis (pin FMA)

Figure 1-1 shows the device functional block diagram for reference.

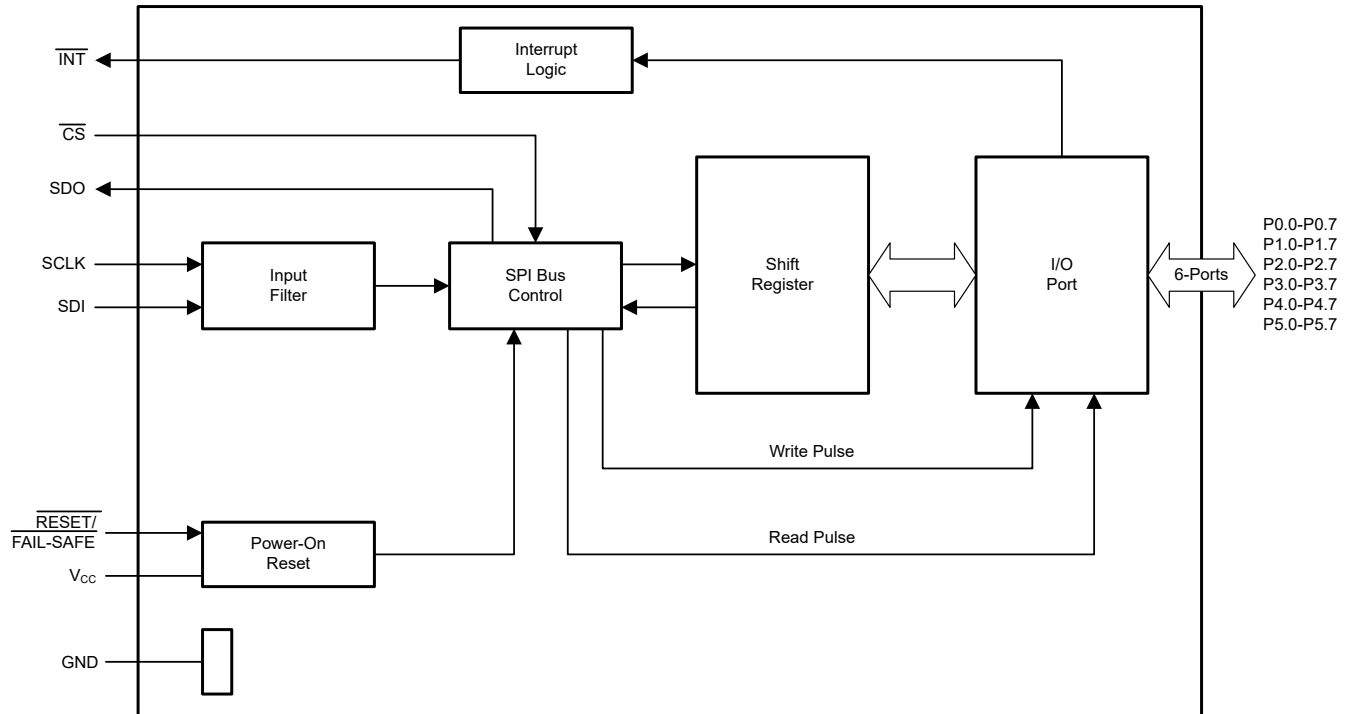

**Figure 1-1. Functional Block Diagram**

The TXE8148 was developed using a quality-managed development process, but was not developed in accordance with the IEC 61508 or ISO 26262 standards.

## 2 Functional Safety Failure In Time (FIT) Rates

### 2.1 TSSOP Package

This section provides functional safety failure in time (FIT) rates for the TSSOP package of the TXE8148 based on two different industry-wide used reliability standards:

- [Table 2-1](#) provides FIT rates based on IEC TR 62380 / ISO 26262 part 11
- [Table 2-2](#) provides FIT rates based on the Siemens Norm SN 29500-2

**Table 2-1. Component Failure Rates per IEC TR 62380 / ISO 26262 Part 11**

FIT IEC TR 62380 / ISO 26262	FIT (Failures Per 10 <sup>9</sup> Hours)
Total component FIT rate	37
Die FIT rate	2
Package FIT rate	35

The failure rate and mission profile information in [Table 2-1](#) comes from the reliability data handbook IEC TR 62380 / ISO 26262 part 11:

- Mission profile: Motor control from table 11 or figure 16
- Power dissipation: 29.8mW
- Climate type: Table 8 or figure 13
- Package factor (lambda 3): Table 17b or figure 15
- Substrate material: FR4
- EOS FIT rate assumed: 0 FIT

**Table 2-2. Component Failure Rates per Siemens Norm SN 29500-2**

Table	Category	Reference FIT Rate	Reference Virtual T <sub>J</sub>
5	CMOS, BICMOS Digital, analog or mixed	60 FIT	70°C

The reference FIT rate and reference virtual T<sub>J</sub> (junction temperature) in [Table 2-2](#) come from the Siemens Norm SN 29500-2 tables 1 through 5. Failure rates under operating conditions are calculated from the reference failure rate and virtual junction temperature using conversion information in SN 29500-2 section 4.

### 3 Failure Mode Distribution (FMD)

The failure mode distribution estimation for TXE8148 in [Table 3-1](#) comes from the combination of common failure modes listed in standards such as IEC 61508 and ISO 26262, the ratio of sub-circuit function size and complexity, and from best engineering judgment.

The failure modes listed in this section reflect random failure events and do not include failures resulting from misuse or overstress.

**Table 3-1. Die Failure Modes and Distribution**

Die Failure Modes	Failure Mode Distribution (%)
SPI communication error	19
Power management (LDO) error	3
Logic blocks error	3
I/O blocks error	75

## 4 Pin Failure Mode Analysis (Pin FMA)

### 4.1 TSSOP Package

This section provides a failure mode analysis (FMA) for the pins of the TXE8148. The failure modes covered in this document include the typical pin-by-pin failure scenarios:

- Pin short-circuited to ground (see [Table 4-2](#))
- Pin open-circuited (see [Table 4-3](#))
- Pin short-circuited to an adjacent pin (see [Table 4-4](#))
- Pin short-circuited to VCC (see [Table 4-5](#))

[Table 4-2](#) through [Table 4-5](#) also indicate how these pin conditions can affect the device as per the failure effects classification in [Table 4-1](#).

**Table 4-1. TI Classification of Failure Effects**

Class	Failure Effects
A	Potential device damage that affects functionality.
B	No device damage, but loss of functionality.
C	No device damage, but performance degradation.
D	No device damage, no impact to functionality or performance.

[Table 4-1](#) shows the TXE8148 pin diagram. For a detailed description of the device pins please refer to the *Pin Configuration and Functions* section in the TXE8148 datasheet.

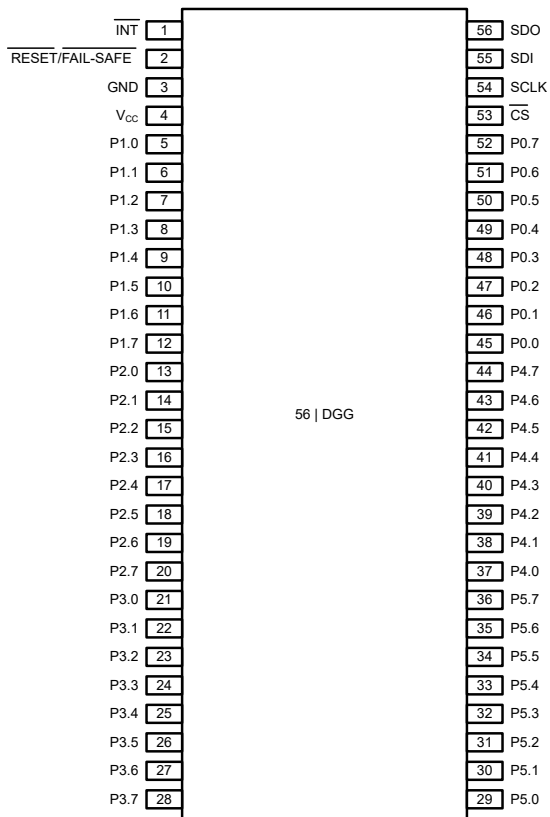

**Figure 4-1. Pin Diagram**

**Table 4-2. Pin FMA for Device Pins Short-Circuited to Ground**

Pin Name	Pin No.	Description of Potential Failure Effects	Failure Effect Class
$\overline{\text{INT}}$	1	The interrupt function is stuck low, and the functionality of the pin is lost.	B
$\overline{\text{RESET/FAIL-SAFE}}$	2	The device is held in reset and all functionality of the pin is lost. All the Px.y pins remain Hi-Z.	B
GND	3	There is no effect on the device. GND is the intended connection for this pin.	D
VCC	4	The device is held in reset and all functionality of the pin is lost. All the Px.y pins become Hi-Z.	B
P0.0 – P0.7 P1.0 – P1.7 P2.0 – P2.7 P3.0 – P3.7 P4.0 – P4.7 P5.0 – P5.7	5 – 52	If the pin is configured to be an output high, damage to the P-Channel FET potentially occurs due to high current draw.	A
		If the pin is configured as an input or output low, functionality of the pin is lost.	B
$\overline{\text{CS}}$	53	Chip select is always in an active state, and SPI communication is not possible.	B
SCLK	54	The communication clock is stuck in a logic-low state, disabling the data shift register from the SDI pin and not allowing SDO data to be available to the controller.	B
SDI	55	The SDI pin is stuck in a logic-low state, which does not allow any data from the controller to be sent through the SPI to the device.	B
SDO	56	The push-pull SDO pin is stuck in a logic-low state. Damage to the P-Channel FET potentially occurs due to high current draw when driving logic-high during communication.	A

**Table 4-3. Pin FMA for Device Pins Open-Circuited**

Pin Name	Pin No.	Description of Potential Failure Effects	Failure Effect Class
$\overline{\text{INT}}$	1	The $\overline{\text{INT}}$ pin can no longer assert low, and the controller cannot be notified of interrupts.	B
$\overline{\text{RESET/FAIL-SAFE}}$	2	A floating $\overline{\text{RESET}}$ pin potentially makes the device unresponsive or affects the programmed pin functions if the pin floats to logic-low.	B
GND	3	The device is not biased to GND. There is damage to the device if GND floats high or low excessively.	A
VCC	4	The functionality of the pin is lost.	B
P0.0 – P0.7 P1.0 – P1.7 P2.0 – P2.7 P3.0 – P3.7 P4.0 – P4.7 P5.0 – P5.7	5 – 52	If the pin is configured to be an input, higher in-rush supply current potentially triggers the $\overline{\text{INT}}$ pin due to a floating input.	B
		If the pin is configured as an output, there is no damage to device.	D
$\overline{\text{CS}}$	53	A floating $\overline{\text{CS}}$ pin potentially makes SPI communication indeterminate, and the functionality of the pin is lost.	B
SCLK	54	A floating SCLK pin potentially makes SPI communicate indeterminate, disabling the data shift register from the SDI pin and not allowing SDO data to be available to the controller.	B
SDI	55	A floating SDI pin potentially causes incorrect data to be latched, and the functionality of the pin is lost.	B
SDO	56	The push-pull SDO pin is stuck in a logic-low state. Damage to the P-Channel FET potentially occurs due to high current draw when driving logic-high during communication.	A

**Table 4-4. Pin FMA for Device Pins Short-Circuited to Adjacent Pin**

Pin Name	Pin No.	Shorted to	Description of Potential Failure Effects	Failure Effect Class
INT	1	RESET/FAIL-SAFE	The device goes into RESET when an interrupt is triggered and functionality is lost.	B
RESET/FAIL-SAFE	2	GND	If the RESET pin is shorted to ground, the device is in a reset state and the functionality of the pin is lost .	A
GND	3	VCC	The device is not powered and all functionality is lost.	B
VCC	4	P1.0	If the P1.0 pin is configured as an output with a logic high level, no issues with the pin are expected.	D
			If the P1.0 pin is configured as an output with a logic low level, then contention between the pins occurs. If the I <sub>OH</sub> specification is exceeded, then damage to the device potentially occurs.	A
			If the P1.0 pin is configured as an input, then damage to the device does not occur.	D
P1.0	5	P1.1	If pins P1.0 and P1.1 are configured as outputs with opposite logic levels, then contention between the pins occur. If the I <sub>OH</sub> specification is exceeded, then damage to the device potentially occurs.	A
			If pins P1.0 and P1.1 are configured as outputs with the same logic level, then damage to the device does not occur.	D
			If pins P1.0 and P1.1 are configured so that one pin is an output and the other pin is an input, then no damage to the device is expected, but this configuration potentially leads to false interrupts.	C
			If pins P1.0 and P1.1 are configured as inputs, then no damage to the device is expected, but this configuration potentially leads to false interrupts.	C
P1.1	6	P1.2	If pins P1.1 and P1.2 are configured as outputs with opposite logic levels, then contention between the pins occur. If the I <sub>OH</sub> specification is exceeded, then damage to the device potentially occurs.	A
			If pins P1.1 and P1.2 are configured as outputs with the same logic level, then damage to the device does not occur.	D
			If pins P1.1 and P1.2 are configured so that one pin is an output and the other pin is an input, then no damage to the device is expected, but this configuration potentially leads to false interrupts.	C
			If pins P1.1 and P1.2 are configured as inputs, then no damage to the device is expected, but this configuration potentially leads to false interrupts.	C
P1.2	7	P1.3	If pins P1.2 and P1.3 are configured as outputs with opposite logic levels, then contention between the pins occur. If the I <sub>OH</sub> specification is exceeded, then damage to the device potentially occurs.	A
			If pins P1.2 and P1.3 are configured as outputs with the same logic level, then damage to the device does not occur.	D
			If pins P1.2 and P1.3 are configured so that one pin is an output and the other pin is an input, then no damage to the device is expected, but this configuration potentially leads to false interrupts.	C
			If pins P1.2 and P1.3 are configured as inputs, then no damage to the device is expected, but this configuration potentially leads to false interrupts.	C
P1.3	8	P1.4	If pins P1.3 and P1.4 are configured as outputs with opposite logic levels, then contention between the pins occur. If the I <sub>OH</sub> specification is exceeded, then damage to the device potentially occurs.	A
			If pins P1.3 and P1.4 are configured as outputs with the same logic level, then damage to the device does not occur.	D
			If pins P1.3 and P1.4 are configured so that one pin is an output and the other pin is an input, then no damage to the device is expected, but this configuration potentially leads to false interrupts.	C
			If pins P1.3 and P1.4 are configured as inputs, then no damage to the device is expected, but this configuration potentially leads to false interrupts.	C

**Table 4-4. Pin FMA for Device Pins Short-Circuited to Adjacent Pin (continued)**

Pin Name	Pin No.	Shorted to	Description of Potential Failure Effects	Failure Effect Class
P1.4	9	P1.5	If pins P1.4 and P1.5 are configured as outputs with opposite logic levels, then contention between the pins occur. If the $I_{OH}$ specification is exceeded, then damage to the device potentially occurs.	A
			If pins P1.4 and P1.5 are configured as outputs with the same logic level, then damage to the device does not occur.	D
			If pins P1.4 and P1.5 are configured so that one pin is an output and the other pin is an input, then no damage to the device is expected, but this configuration potentially leads to false interrupts.	C
			If pins P1.4 and P1.5 are configured as inputs, then no damage to the device is expected, but this configuration potentially leads to false interrupts.	C
P1.5	10	P1.6	If pins P1.5 and P1.6 are configured as outputs with opposite logic levels, then contention between the pins occur. If the $I_{OH}$ specification is exceeded, then damage to the device potentially occurs.	A
			If pins P1.5 and P1.6 are configured as outputs with the same logic level, then damage to the device does not occur.	D
			If pins P1.5 and P1.6 are configured so that one pin is an output and the other pin is an input, then no damage to the device is expected, but this configuration potentially leads to false interrupts.	C
			If pins P1.5 and P1.6 are configured as inputs, then no damage to the device is expected, but this configuration potentially leads to false interrupts.	C
P1.6	11	P1.7	If pins P1.6 and P1.7 are configured as outputs with opposite logic levels, then contention between the pins occur. If the $I_{OH}$ specification is exceeded, then damage to the device potentially occurs.	A
			If pins P1.6 and P1.7 are configured as outputs with the same logic level, then damage to the device does not occur.	D
			If pins P1.6 and P1.7 are configured so that one pin is an output and the other pin is an input, then no damage to the device is expected, but this configuration potentially leads to false interrupts.	C
			If pins P1.6 and P1.7 are configured as inputs, then no damage to the device is expected, but this configuration potentially leads to false interrupts.	C
P1.7	12	P2.0	If pins P1.7 and P2.0 are configured as outputs with opposite logic levels, then contention between the pins occur. If the $I_{OH}$ specification is exceeded, then damage to the device potentially occurs.	A
			If pins P1.7 and P2.0 are configured as outputs with the same logic level, then damage to the device does not occur.	D
			If pins P1.7 and P2.0 are configured so that one pin is an output and the other pin is an input, then no damage to the device is expected, but this configuration potentially leads to false interrupts.	C
			If pins P1.7 and P2.0 are configured as inputs, then no damage to the device is expected, but this configuration potentially leads to false interrupts.	C
P2.0	13	P2.1	If pins P2.0 and P2.1 are configured as outputs with opposite logic levels, then contention between the pins occur. If the $I_{OH}$ specification is exceeded, then damage to the device potentially occurs.	A
			If pins P2.0 and P2.1 are configured as outputs with the same logic level, then damage to the device does not occur.	D
			If pins P2.0 and P2.1 are configured so that one pin is an output and the other pin is an input, then no damage to the device is expected, but this configuration potentially leads to false interrupts.	C
			If pins P2.0 and P2.1 are configured as inputs, then no damage to the device is expected, but this configuration potentially leads to false interrupts.	C

**Table 4-4. Pin FMA for Device Pins Short-Circuited to Adjacent Pin (continued)**

Pin Name	Pin No.	Shorted to	Description of Potential Failure Effects	Failure Effect Class
P2.1	14	P2.2	If pins P2.1 and P2.2 are configured as outputs with opposite logic levels, then contention between the pins occur. If the I <sub>OH</sub> specification is exceeded, then damage to the device potentially occurs.	A
			If pins P2.1 and P2.2 are configured as outputs with the same logic level, then damage to the device does not occur.	D
			If pins P2.1 and P2.2 are configured so that one pin is an output and the other pin is an input, then no damage to the device is expected, but this configuration potentially leads to false interrupts.	C
			If pins P2.1 and P2.2 are configured as inputs, then no damage to the device is expected, but this configuration potentially leads to false interrupts.	C
P2.2	15	P2.3	If pins P2.2 and P2.3 are configured as outputs with opposite logic levels, then contention between the pins occur. If the I <sub>OH</sub> specification is exceeded, then damage to the device potentially occurs.	A
			If pins P2.2 and P2.3 are configured as outputs with the same logic level, then damage to the device does not occur.	D
			If pins P2.2 and P2.3 are configured so that one pin is an output and the other pin is an input, then no damage to the device is expected, but this configuration potentially leads to false interrupts.	C
			If pins P2.2 and P2.3 are configured as inputs, then no damage to the device is expected, but this configuration potentially leads to false interrupts.	C
P2.3	16	P2.4	If pins P2.3 and P2.4 are configured as outputs with opposite logic levels, then contention between the pins occur. If the I <sub>OH</sub> specification is exceeded, then damage to the device potentially occurs.	A
			If pins P2.3 and P2.4 are configured as outputs with the same logic level, then damage to the device does not occur.	D
			If pins P2.3 and P2.4 are configured so that one pin is an output and the other pin is an input, then no damage to the device is expected, but this configuration potentially leads to false interrupts.	C
			If pins P2.3 and P2.4 are configured as inputs, then no damage to the device is expected, but this configuration potentially leads to false interrupts.	C
P2.4	17	P2.5	If pins P2.4 and P2.5 are configured as outputs with opposite logic levels, then contention between the pins occur. If the I <sub>OH</sub> specification is exceeded, then damage to the device potentially occurs.	A
			If pins P2.4 and P2.5 are configured as outputs with the same logic level, then damage to the device does not occur.	D
			If pins P2.4 and P2.5 are configured so that one pin is an output and the other pin is an input, then no damage to the device is expected, but this configuration potentially leads to false interrupts.	C
			If pins P2.4 and P2.5 are configured as inputs, then no damage to the device is expected, but this configuration potentially leads to false interrupts.	C
P2.5	18	P2.6	If pins P2.5 and P2.6 are configured as outputs with opposite logic levels, then contention between the pins occur. If the I <sub>OH</sub> specification is exceeded, then damage to the device potentially occurs.	A
			If pins P2.5 and P2.6 are configured as outputs with the same logic level, then damage to the device does not occur.	D
			If pins P2.5 and P2.6 are configured so that one pin is an output and the other pin is an input, then no damage to the device is expected, but this configuration potentially leads to false interrupts.	C
			If pins P2.5 and P2.6 are configured as inputs, then no damage to the device is expected, but this configuration potentially leads to false interrupts.	C

**Table 4-4. Pin FMA for Device Pins Short-Circuited to Adjacent Pin (continued)**

Pin Name	Pin No.	Shorted to	Description of Potential Failure Effects	Failure Effect Class
P2.6	19	P2.7	If pins P2.6 and P2.7 are configured as outputs with opposite logic levels, then contention between the pins occur. If the $I_{OH}$ specification is exceeded, then damage to the device potentially occurs.	A
			If pins P2.6 and P2.7 are configured as outputs with the same logic level, then damage to the device does not occur.	D
			If pins P2.6 and P2.7 are configured so that one pin is an output and the other pin is an input, then no damage to the device is expected, but this configuration potentially leads to false interrupts.	C
			If pins P2.6 and P2.7 are configured as inputs, then no damage to the device is expected, but this configuration potentially leads to false interrupts.	C
P2.7	20	P3.0	If pins P2.7 and P3.0 are configured as outputs with opposite logic levels, then contention between the pins occur. If the $I_{OH}$ specification is exceeded, then damage to the device potentially occurs.	A
			If pins P2.7 and P3.0 are configured as outputs with the same logic level, then damage to the device does not occur.	D
			If pins P2.7 and P3.0 are configured so that one pin is an output and the other pin is an input, then no damage to the device is expected, but this configuration potentially leads to false interrupts.	C
			If pins P2.7 and P3.0 are configured as inputs, then no damage to the device is expected, but this configuration potentially leads to false interrupts.	C
P3.0	21	P3.1	If pins P3.0 and P3.1 are configured as outputs with opposite logic levels, then contention between the pins occur. If the $I_{OH}$ specification is exceeded, then damage to the device potentially occurs.	A
			If pins P3.0 and P3.1 are configured as outputs with the same logic level, then damage to the device does not occur.	D
			If pins P3.0 and P3.1 are configured so that one pin is an output and the other pin is an input, then no damage to the device is expected, but this configuration potentially leads to false interrupts.	C
			If pins P3.0 and P3.1 are configured as inputs, then no damage to the device is expected, but this configuration potentially leads to false interrupts.	C
P3.1	22	P3.2	If pins P3.1 and P3.2 are configured as outputs with opposite logic levels, then contention between the pins occur. If the $I_{OH}$ specification is exceeded, then damage to the device potentially occurs.	A
			If pins P3.1 and P3.2 are configured as outputs with the same logic level, then damage to the device does not occur.	D
			If pins P3.1 and P3.2 are configured so that one pin is an output and the other pin is an input, then no damage to the device is expected, but this configuration potentially leads to false interrupts.	C
			If pins P3.1 and P3.2 are configured as inputs, then no damage to the device is expected, but this configuration potentially leads to false interrupts.	C
P3.2	23	P3.3	If pins P3.2 and P3.3 are configured as outputs with opposite logic levels, then contention between the pins occur. If the $I_{OH}$ specification is exceeded, then damage to the device potentially occurs.	A
			If pins P3.2 and P3.3 are configured as outputs with the same logic level, then damage to the device does not occur.	D
			If pins P3.2 and P3.3 are configured so that one pin is an output and the other pin is an input, then no damage to the device is expected, but this configuration potentially leads to false interrupts.	C
			If pins P3.2 and P3.3 are configured as inputs, then no damage to the device is expected, but this configuration potentially leads to false interrupts.	C

**Table 4-4. Pin FMA for Device Pins Short-Circuited to Adjacent Pin (continued)**

Pin Name	Pin No.	Shorted to	Description of Potential Failure Effects	Failure Effect Class
P3.3	24	P3.4	If pins P3.3 and P3.4 are configured as outputs with opposite logic levels, then contention between the pins occur. If the I <sub>OH</sub> specification is exceeded, then damage to the device potentially occurs.	A
			If pins P3.3 and P3.4 are configured as outputs with the same logic level, then damage to the device does not occur.	D
			If pins P3.3 and P3.4 are configured so that one pin is an output and the other pin is an input, then no damage to the device is expected, but this configuration potentially leads to false interrupts.	C
			If pins P3.3 and P3.4 are configured as inputs, then no damage to the device is expected, but this configuration potentially leads to false interrupts.	C
P3.4	25	P3.5	If pins P3.4 and P3.5 are configured as outputs with opposite logic levels, then contention between the pins occur. If the I <sub>OH</sub> specification is exceeded, then damage to the device potentially occurs.	A
			If pins P3.4 and P3.5 are configured as outputs with the same logic level, then damage to the device does not occur.	D
			If pins P3.4 and P3.5 are configured so that one pin is an output and the other pin is an input, then no damage to the device is expected, but this configuration potentially leads to false interrupts.	C
			If pins P3.4 and P3.5 are configured as inputs, then no damage to the device is expected, but this configuration potentially leads to false interrupts.	C
P3.5	26	P3.6	If pins P3.5 and P3.6 are configured as outputs with opposite logic levels, then contention between the pins occur. If the I <sub>OH</sub> specification is exceeded, then damage to the device potentially occurs.	A
			If pins P3.5 and P3.6 are configured as outputs with the same logic level, then damage to the device does not occur.	D
			If pins P3.5 and P3.6 are configured so that one pin is an output and the other pin is an input, then no damage to the device is expected, but this configuration potentially leads to false interrupts.	C
			If pins P3.5 and P3.6 are configured as inputs, then no damage to the device is expected, but this configuration potentially leads to false interrupts.	C
P3.6	27	P3.7	If pins P3.6 and P3.7 are configured as outputs with opposite logic levels, then contention between the pins occur. If the I <sub>OH</sub> specification is exceeded, then damage to the device potentially occurs.	A
			If pins P3.6 and P3.7 are configured as outputs with the same logic level, then damage to the device does not occur.	D
			If pins P3.6 and P3.7 are configured so that one pin is an output and the other pin is an input, then no damage to the device is expected, but this configuration potentially leads to false interrupts.	C
			If pins P3.6 and P3.7 are configured as inputs, then no damage to the device is expected, but this configuration potentially leads to false interrupts.	C
P5.0	29	P5.1	If pins P5.0 and P5.1 are configured as outputs with opposite logic levels, then contention between the pins occur. If the I <sub>OH</sub> specification is exceeded, then damage to the device potentially occurs.	A
			If pins P5.0 and P5.1 are configured as outputs with the same logic level, then damage to the device does not occur.	D
			If pins P5.0 and P5.1 are configured so that one pin is an output and the other pin is an input, then no damage to the device is expected, but this configuration potentially leads to false interrupts.	C
			If pins P5.0 and P5.1 are configured as inputs, then no damage to the device is expected, but this configuration potentially leads to false interrupts.	C

**Table 4-4. Pin FMA for Device Pins Short-Circuited to Adjacent Pin (continued)**

Pin Name	Pin No.	Shorted to	Description of Potential Failure Effects	Failure Effect Class
P5.1	30	P5.2	If pins P5.1 and P5.2 are configured as outputs with opposite logic levels, then contention between the pins occur. If the $I_{OH}$ specification is exceeded, then damage to the device potentially occurs.	A
			If pins P5.1 and P5.2 are configured as outputs with the same logic level, then damage to the device does not occur.	D
			If pins P5.1 and P5.2 are configured so that one pin is an output and the other pin is an input, then no damage to the device is expected, but this configuration potentially leads to false interrupts.	C
			If pins P5.1 and P5.2 are configured as inputs, then no damage to the device is expected, but this configuration potentially leads to false interrupts.	C
P5.2	31	P5.3	If pins P5.2 and P5.3 are configured as outputs with opposite logic levels, then contention between the pins occur. If the $I_{OH}$ specification is exceeded, then damage to the device potentially occurs.	A
			If pins P5.2 and P5.3 are configured as outputs with the same logic level, then damage to the device does not occur.	D
			If pins P5.2 and P5.3 are configured so that one pin is an output and the other pin is an input, then no damage to the device is expected, but this configuration potentially leads to false interrupts.	C
			If pins P5.2 and P5.3 are configured as inputs, then no damage to the device is expected, but this configuration potentially leads to false interrupts.	C
P5.3	32	P5.4	If pins P5.3 and P5.4 are configured as outputs with opposite logic levels, then contention between the pins occur. If the $I_{OH}$ specification is exceeded, then damage to the device potentially occurs.	A
			If pins P5.3 and P5.4 are configured as outputs with the same logic level, then damage to the device does not occur.	D
			If pins P5.3 and P5.4 are configured so that one pin is an output and the other pin is an input, then no damage to the device is expected, but this configuration potentially leads to false interrupts.	C
			If pins P5.3 and P5.4 are configured as inputs, then no damage to the device is expected, but this configuration potentially leads to false interrupts.	C
P5.4	33	P5.5	If pins P5.4 and P5.5 are configured as outputs with opposite logic levels, then contention between the pins occur. If the $I_{OH}$ specification is exceeded, then damage to the device potentially occurs.	A
			If pins P5.4 and P5.5 are configured as outputs with the same logic level, then damage to the device does not occur.	D
			If pins P5.4 and P5.5 are configured so that one pin is an output and the other pin is an input, then no damage to the device is expected, but this configuration potentially leads to false interrupts.	C
			If pins P5.4 and P5.5 are configured as inputs, then no damage to the device is expected, but this configuration potentially leads to false interrupts.	C
P5.5	34	P5.6	If pins P5.5 and P5.6 are configured as outputs with opposite logic levels, then contention between the pins occur. If the $I_{OH}$ specification is exceeded, then damage to the device potentially occurs.	A
			If pins P5.5 and P5.6 are configured as outputs with the same logic level, then damage to the device does not occur.	D
			If pins P5.5 and P5.6 are configured so that one pin is an output and the other pin is an input, then no damage to the device is expected, but this configuration potentially leads to false interrupts.	C
			If pins P5.5 and P5.6 are configured as inputs, then no damage to the device is expected, but this configuration potentially leads to false interrupts.	C

**Table 4-4. Pin FMA for Device Pins Short-Circuited to Adjacent Pin (continued)**

Pin Name	Pin No.	Shorted to	Description of Potential Failure Effects	Failure Effect Class
P5.6	35	P5.7	If pins P5.6 and P5.7 are configured as outputs with opposite logic levels, then contention between the pins occur. If the I <sub>OH</sub> specification is exceeded, then damage to the device potentially occurs.	A
			If pins P5.6 and P5.7 are configured as outputs with the same logic level, then damage to the device does not occur.	D
			If pins P5.6 and P5.7 are configured so that one pin is an output and the other pin is an input, then no damage to the device is expected, but this configuration potentially leads to false interrupts.	C
			If pins P5.6 and P5.7 are configured as inputs, then no damage to the device is expected, but this configuration potentially leads to false interrupts.	C
P5.7	36	P4.0	If pins P5.7 and P4.0 are configured as outputs with opposite logic levels, then contention between the pins occur. If the I <sub>OH</sub> specification is exceeded, then damage to the device potentially occurs.	A
			If pins P5.7 and P4.0 are configured as outputs with the same logic level, then damage to the device does not occur.	D
			If pins P5.7 and P4.0 are configured so that one pin is an output and the other pin is an input, then no damage to the device is expected, but this configuration potentially leads to false interrupts.	C
			If pins P5.7 and P4.0 are configured as inputs, then no damage to the device is expected, but this configuration potentially leads to false interrupts.	C
P4.0	37	P4.1	If pins P4.0 and P4.1 are configured as outputs with opposite logic levels, then contention between the pins occur. If the I <sub>OH</sub> specification is exceeded, then damage to the device potentially occurs.	A
			If pins P4.0 and P4.1 are configured as outputs with the same logic level, then damage to the device does not occur.	D
			If pins P4.0 and P4.1 are configured so that one pin is an output and the other pin is an input, then no damage to the device is expected, but this configuration potentially leads to false interrupts.	C
			If pins P4.0 and P4.1 are configured as inputs, then no damage to the device is expected, but this configuration potentially leads to false interrupts.	C
P4.1	38	P4.2	If pins P4.1 and P4.2 are configured as outputs with opposite logic levels, then contention between the pins occur. If the I <sub>OH</sub> specification is exceeded, then damage to the device potentially occurs.	A
			If pins P4.1 and P4.2 are configured as outputs with the same logic level, then damage to the device does not occur.	D
			If pins P4.1 and P4.2 are configured so that one pin is an output and the other pin is an input, then no damage to the device is expected, but this configuration potentially leads to false interrupts.	C
			If pins P4.1 and P4.2 are configured as inputs, then no damage to the device is expected, but this configuration potentially leads to false interrupts.	C
P4.2	39	P4.3	If pins P4.2 and P4.3 are configured as outputs with opposite logic levels, then contention between the pins occur. If the I <sub>OH</sub> specification is exceeded, then damage to the device potentially occurs.	A
			If pins P4.2 and P4.3 are configured as outputs with the same logic level, then damage to the device does not occur.	D
			If pins P4.2 and P4.3 are configured so that one pin is an output and the other pin is an input, then no damage to the device is expected, but this configuration potentially leads to false interrupts.	C
			If pins P4.2 and P4.3 are configured as inputs, then no damage to the device is expected, but this configuration potentially leads to false interrupts.	C

**Table 4-4. Pin FMA for Device Pins Short-Circuited to Adjacent Pin (continued)**

Pin Name	Pin No.	Shorted to	Description of Potential Failure Effects	Failure Effect Class
P4.3	40	P4.4	If pins P4.3 and P4.4 are configured as outputs with opposite logic levels, then contention between the pins occur. If the $I_{OH}$ specification is exceeded, then damage to the device potentially occurs.	A
			If pins P4.3 and P4.4 are configured as outputs with the same logic level, then damage to the device does not occur.	D
			If pins P4.3 and P4.4 are configured so that one pin is an output and the other pin is an input, then no damage to the device is expected, but this configuration potentially leads to false interrupts.	C
			If pins P4.3 and P4.4 are configured as inputs, then no damage to the device is expected, but this configuration potentially leads to false interrupts.	C
P4.4	41	P4.5	If pins P4.4 and P4.5 are configured as outputs with opposite logic levels, then contention between the pins occur. If the $I_{OH}$ specification is exceeded, then damage to the device potentially occurs.	A
			If pins P4.4 and P4.5 are configured as outputs with the same logic level, then damage to the device does not occur.	D
			If pins P4.4 and P4.5 are configured so that one pin is an output and the other pin is an input, then no damage to the device is expected, but this configuration potentially leads to false interrupts.	C
			If pins P4.4 and P4.5 are configured as inputs, then no damage to the device is expected, but this configuration potentially leads to false interrupts.	C
P4.5	42	P4.6	If pins P4.5 and P4.6 are configured as outputs with opposite logic levels, then contention between the pins occur. If the $I_{OH}$ specification is exceeded, then damage to the device potentially occurs.	A
			If pins P4.5 and P4.6 are configured as outputs with the same logic level, then damage to the device does not occur.	D
			If pins P4.5 and P4.6 are configured so that one pin is an output and the other pin is an input, then no damage to the device is expected, but this configuration potentially leads to false interrupts.	C
			If pins P4.5 and P4.6 are configured as inputs, then no damage to the device is expected, but this configuration potentially leads to false interrupts.	C
P4.6	43	P4.7	If pins P4.6 and P4.7 are configured as outputs with opposite logic levels, then contention between the pins occur. If the $I_{OH}$ specification is exceeded, then damage to the device potentially occurs.	A
			If pins P4.6 and P4.7 are configured as outputs with the same logic level, then damage to the device does not occur.	D
			If pins P4.6 and P4.7 are configured so that one pin is an output and the other pin is an input, then no damage to the device is expected, but this configuration potentially leads to false interrupts.	C
			If pins P4.6 and P4.7 are configured as inputs, then no damage to the device is expected, but this configuration potentially leads to false interrupts.	C
P4.7	44	P0.0	If pins P4.7 and P0.0 are configured as outputs with opposite logic levels, then contention between the pins occur. If the $I_{OH}$ specification is exceeded, then damage to the device potentially occurs.	A
			If pins P4.7 and P0.0 are configured as outputs with the same logic level, then damage to the device does not occur.	D
			If pins P4.7 and P0.0 are configured so that one pin is an output and the other pin is an input, then no damage to the device is expected, but this configuration potentially leads to false interrupts.	C
			If pins P4.7 and P0.0 are configured as inputs, then no damage to the device is expected, but this configuration potentially leads to false interrupts.	C

**Table 4-4. Pin FMA for Device Pins Short-Circuited to Adjacent Pin (continued)**

Pin Name	Pin No.	Shorted to	Description of Potential Failure Effects	Failure Effect Class
P0.0	45	P0.1	If pins P0.0 and P0.1 are configured as outputs with opposite logic levels, then contention between the pins occur. If the I <sub>OH</sub> specification is exceeded, then damage to the device potentially occurs.	A
			If pins P0.0 and P0.1 are configured as outputs with the same logic level, then damage to the device does not occur.	D
			If pins P0.0 and P0.1 are configured so that one pin is an output and the other pin is an input, then no damage to the device is expected, but this configuration potentially leads to false interrupts.	C
			If pins P0.0 and P0.1 are configured as inputs, then no damage to the device is expected, but this configuration potentially leads to false interrupts.	C
P0.1	46	P0.2	If pins P0.1 and P0.2 are configured as outputs with opposite logic levels, then contention between the pins occur. If the I <sub>OH</sub> specification is exceeded, then damage to the device potentially occurs.	A
			If pins P0.1 and P0.2 are configured as outputs with the same logic level, then damage to the device does not occur.	D
			If pins P0.1 and P0.2 are configured so that one pin is an output and the other pin is an input, then no damage to the device is expected, but this configuration potentially leads to false interrupts.	C
			If pins P0.1 and P0.2 are configured as inputs, then no damage to the device is expected, but this configuration potentially leads to false interrupts.	C
P0.2	47	P0.3	If pins P0.2 and P0.3 are configured as outputs with opposite logic levels, then contention between the pins occur. If the I <sub>OH</sub> specification is exceeded, then damage to the device potentially occurs.	A
			If pins P0.2 and P0.3 are configured as outputs with the same logic level, then damage to the device does not occur.	D
			If pins P0.2 and P0.3 are configured so that one pin is an output and the other pin is an input, then no damage to the device is expected, but this configuration potentially leads to false interrupts.	C
			If pins P0.2 and P0.3 are configured as inputs, then no damage to the device is expected, but this configuration potentially leads to false interrupts.	C
P0.3	48	P0.4	If pins P0.3 and P0.4 are configured as outputs with opposite logic levels, then contention between the pins occur. If the I <sub>OH</sub> specification is exceeded, then damage to the device potentially occurs.	A
			If pins P0.3 and P0.4 are configured as outputs with the same logic level, then damage to the device does not occur.	D
			If pins P0.3 and P0.4 are configured so that one pin is an output and the other pin is an input, then no damage to the device is expected, but this configuration potentially leads to false interrupts.	C
			If pins P0.3 and P0.4 are configured as inputs, then no damage to the device is expected, but this configuration potentially leads to false interrupts.	C
P0.4	49	P0.5	If pins P0.4 and P0.5 are configured as outputs with opposite logic levels, then contention between the pins occur. If the I <sub>OH</sub> specification is exceeded, then damage to the device potentially occurs.	A
			If pins P0.4 and P0.5 are configured as outputs with the same logic level, then damage to the device does not occur.	D
			If pins P0.4 and P0.5 are configured so that one pin is an output and the other pin is an input, then no damage to the device is expected, but this configuration potentially leads to false interrupts.	C
			If pins P0.4 and P0.5 are configured as inputs, then no damage to the device is expected, but this configuration potentially leads to false interrupts.	C

**Table 4-4. Pin FMA for Device Pins Short-Circuited to Adjacent Pin (continued)**

Pin Name	Pin No.	Shorted to	Description of Potential Failure Effects	Failure Effect Class
P0.5	50	P0.6	If pins P0.5 and P0.6 are configured as outputs with opposite logic levels, then contention between the pins occur. If the $I_{OH}$ specification is exceeded, then damage to the device potentially occurs.	A
			If pins P0.5 and P0.6 are configured as outputs with the same logic level, then damage to the device does not occur.	D
			If pins P0.5 and P0.6 are configured so that one pin is an output and the other pin is an input, then no damage to the device is expected, but this configuration potentially leads to false interrupts.	C
			If pins P0.5 and P0.6 are configured as inputs, then no damage to the device is expected, but this configuration potentially leads to false interrupts.	C
P0.6	51	P0.7	If pins P0.6 and P0.7 are configured as outputs with opposite logic levels, then contention between the pins occur. If the $I_{OH}$ specification is exceeded, then damage to the device potentially occurs.	A
			If pins P0.6 and P0.7 are configured as outputs with the same logic level, then damage to the device does not occur.	D
			If pins P0.6 and P0.7 are configured so that one pin is an output and the other pin is an input, then no damage to the device is expected, but this configuration potentially leads to false interrupts.	C
			If pins P0.6 and P0.7 are configured as inputs, then no damage to the device is expected, but this configuration potentially leads to false interrupts.	C
P0.7	52	$\overline{CS}$	If pin P0.7 is an input, false interrupts potentially occur when the $\overline{CS}$ pin toggles.	C
			If pin P0.7 is as output, $\overline{CS}$ is potentially unusable and functionality is lost.	B
$\overline{CS}$	53	SCLK	The $\overline{CS}$ pin toggles with the SCLK pin, SPI communication is not usable, and functionality is lost.	B
SCLK	54	SDI	SPI communication to the device is incorrect and functionality is lost.	B
SDI	55	SDO	SPI communication to the device is incorrect and functionality is lost.	B

**Table 4-5. Pin FMA for Device Pins Short-Circuited to VCC**

Pin Name	Pin No.	Description of Potential Failure Effects	Failure Effect Class
$\overline{\text{INT}}$	1	If the $\overline{\text{INT}}$ pin is asserted low, damage to the N-Channel FET potentially occurs due to high current sink.	A
RESET / FAIL-SAFE	2	If the RESET pin is tied to a pullup voltage, then higher leakage currents potentially occur.	C
		If the $\overline{\text{RESET}}$ pin is tied to a pullup voltage, and an external circuit attempts to drive the $\overline{\text{RESET}}$ , the device is not able to be reset through this hardware pin.	B
GND	3	The device is not powered and all functionality is lost.	B
VCC	4	There is no effect on the device. This is the intended use of this pin.	D
P0.0 – P0.7 P1.0 – P1.7 P2.0 – P2.7 P3.0 – P3.7 P4.0 – P4.7 P5.0 – P5.7	5 – 52	If the pin is configured as an input or output high, the functionality of the pin is lost.	B
		If the pin is configured to be an output low, damage to the N-Channel FET potentially occurs due to high current sink.	A
$\overline{\text{CS}}$	53	The chip select pin is stuck in the logic-high state, SPI communication is not possible.	B
SCLK	54	The communication clock is stuck in a logic-low state, disabling the data shift register from the SDI pin and not allowing SDO data to be available to the controller.	B
SDI	55	The SDI pin is stuck in a logic-low state, which does not allow any data from the controller to be sent through the SPI to the device.	B
SDO	56	The push-pull SDO pin is stuck in a logic-high state. Damage to the N-Channel FET potentially occurs due to high current sink when driving logic-high during communication.	A

## 5 Revision History

NOTE: Page numbers for previous revisions may differ from page numbers in the current version.

DATE	REVISION	NOTES
May 2026	*	Initial Release

## IMPORTANT NOTICE AND DISCLAIMER

TI PROVIDES TECHNICAL AND RELIABILITY DATA (INCLUDING DATASHEETS), DESIGN RESOURCES (INCLUDING REFERENCE DESIGNS), APPLICATION OR OTHER DESIGN ADVICE, WEB TOOLS, SAFETY INFORMATION, AND OTHER RESOURCES "AS IS" AND WITH ALL FAULTS, AND DISCLAIMS ALL WARRANTIES, EXPRESS AND IMPLIED, INCLUDING WITHOUT LIMITATION ANY IMPLIED WARRANTIES OF MERCHANTABILITY, FITNESS FOR A PARTICULAR PURPOSE OR NON-INFRINGEMENT OF THIRD PARTY INTELLECTUAL PROPERTY RIGHTS.

These resources are intended for skilled developers designing with TI products. You are solely responsible for (1) selecting the appropriate TI products for your application, (2) designing, validating and testing your application, and (3) ensuring your application meets applicable standards, and any other safety, security, regulatory or other requirements.

These resources are subject to change without notice. TI grants you permission to use these resources only for development of an application that uses the TI products described in the resource. Other reproduction and display of these resources is prohibited. No license is granted to any other TI intellectual property right or to any third party intellectual property right. TI disclaims responsibility for, and you fully indemnify TI and its representatives against any claims, damages, costs, losses, and liabilities arising out of your use of these resources.

TI's products are provided subject to [TI's Terms of Sale](#), [TI's General Quality Guidelines](#), or other applicable terms available either on [ti.com](http://ti.com) or provided in conjunction with such TI products. TI's provision of these resources does not expand or otherwise alter TI's applicable warranties or warranty disclaimers for TI products. Unless TI explicitly designates a product as custom or customer-specified, TI products are standard, catalog, general purpose devices.

TI objects to and rejects any additional or different terms you may propose.

Copyright © 2026, Texas Instruments Incorporated

Last updated 10/2025