

SN74AVC4T774-Q1 Functional Safety FIT Rate, FMD and Pin FMA



Table of Contents

1 Overview	2
2 Functional Safety Failure In Time (FIT) Rates	3
2.1 TSSOP Package.....	3
2.2 VQFN Package.....	4
2.3 UQFN Package.....	5
3 Failure Mode Distribution (FMD)	6
4 Pin Failure Mode Analysis (Pin FMA)	7

Trademarks

All trademarks are the property of their respective owners.

1 Overview

This document contains information for SN74AVC4T774-Q1 (TSSOP, VQFN, and UQFN packages) to aid in a functional safety system design. Information provided are:

- Functional Safety Failure In Time (FIT) rates of the semiconductor component estimated by the application of industry reliability standards
- Component failure modes and their distribution (FMD) based on the primary function of the device

Figure 1-1 shows the device functional block diagram for reference.

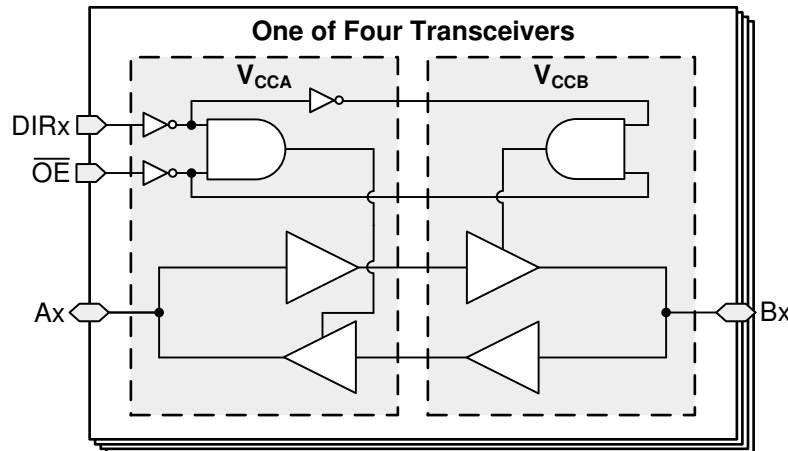

Figure 1-1. Functional Block Diagram

SN74AVC4T774-Q1 was developed using a quality-managed development process, but was not developed in accordance with the IEC 61508 or ISO 26262 standards.

2 Functional Safety Failure In Time (FIT) Rates

2.1 TSSOP Package

This section provides Functional Safety Failure In Time (FIT) rates for TSSOP package of SN74AVC4T774-Q1:

- [Table 2-1](#) provides FIT rates based on IEC TR 62380 / ISO 26262 part 11
- [Table 2-2](#) provides FIT rates based on the Siemens Norm SN 29500-2.

Table 2-1. Component Failure Rates per IEC TR 62380 / ISO 26262 Part 11

FIT IEC TR 62380 / ISO 26262	FIT (Failures Per 10 ⁹ Hours)
Total Component FIT Rate	15
Die FIT Rate	2
Package FIT Rate	13

The failure rate and mission profile information in [Table 2-1](#) comes from the Reliability data handbook IEC TR 62380 / ISO 26262 part 11:

- Mission Profile: Motor Control from Table 11
- Power dissipation: 19 mW
- Climate type: World-wide Table 8
- Package factor (lambda 3): Table 17b
- Substrate Material: FR4
- EOS FIT rate assumed: 0 FIT

Table 2-2. Component Failure Rates per Siemens Norm SN 29500-2

Table	Category	Reference FIT Rate	Reference Virtual T _J
5	BICMOS Bus interface LVT, ALVT	5 FIT	55°C

The Reference FIT Rate and Reference Virtual T_J (junction temperature) in [Table 2-2](#) come from the Siemens Norm SN 29500-2 tables 1 through 5. Failure rates under operating conditions are calculated from the reference failure rate and virtual junction temperature using conversion information in SN 29500-2 section 4.

2.2 VQFN Package

This section provides Functional Safety Failure In Time (FIT) rates for the VQFN package of SN74AVC4T774-Q1:

- [Table 2-3](#) provides FIT rates based on IEC TR 62380 / ISO 26262 part 11
- [Table 2-4](#) provides FIT rates based on the Siemens Norm SN 29500-2.

Table 2-3. Component Failure Rates per IEC TR 62380 / ISO 26262 Part 11

FIT IEC TR 62380 / ISO 26262	FIT (Failures Per 10 ⁹ Hours)
Total Component FIT Rate	7
Die FIT Rate	2
Package FIT Rate	5

The failure rate and mission profile information in [Table 2-3](#) comes from the Reliability data handbook IEC TR 62380 / ISO 26262 part 11:

- Mission Profile: Motor Control from Table 11
- Power dissipation: 19 mW
- Climate type: World-wide Table 8
- Package factor (lambda 3): Table 17b
- Substrate Material: FR4
- EOS FIT rate assumed: 0 FIT

Table 2-4. Component Failure Rates per Siemens Norm SN 29500-2

Table	Category	Reference FIT Rate	Reference Virtual T _j
5	BICMOS Bus interface LVT, ALVT	5 FIT	55°C

The Reference FIT Rate and Reference Virtual T_j (junction temperature) in [Table 2-4](#) come from the Siemens Norm SN 29500-2 tables 1 through 5. Failure rates under operating conditions are calculated from the reference failure rate and virtual junction temperature using conversion information in SN 29500-2 section 4.

2.3 UQFN Package

This section provides Functional Safety Failure In Time (FIT) rates for the UQFN package of SN74AVC4T774-Q1:

- [Table 2-5](#) provides FIT rates based on IEC TR 62380 / ISO 26262 part 11
- [Table 2-6](#) provides FIT rates based on the Siemens Norm SN 29500-2.

Table 2-5. Component Failure Rates per IEC TR 62380 / ISO 26262 Part 11

FIT IEC TR 62380 / ISO 26262	FIT (Failures Per 10 ⁹ Hours)
Total Component FIT Rate	8
Die FIT Rate	2
Package FIT Rate	6

The failure rate and mission profile information in [Table 2-5](#) comes from the Reliability data handbook IEC TR 62380 / ISO 26262 part 11:

- Mission Profile: Motor Control from Table 11
- Power dissipation: 19 mW
- Climate type: World-wide Table 8
- Package factor (lambda 3): Table 17b
- Substrate Material: FR4
- EOS FIT rate assumed: 0 FIT

Table 2-6. Component Failure Rates per Siemens Norm SN 29500-2

Table	Category	Reference FIT Rate	Reference Virtual T _j
5	BICMOS Bus interface LVT, ALVT	5 FIT	55°C

The Reference FIT Rate and Reference Virtual T_j (junction temperature) in [Table 2-6](#) come from the Siemens Norm SN 29500-2 tables 1 through 5. Failure rates under operating conditions are calculated from the reference failure rate and virtual junction temperature using conversion information in SN 29500-2 section 4.

3 Failure Mode Distribution (FMD)

The failure mode distribution estimation for SN74AVC4T774-Q1 in [Table 3-1](#) comes from the combination of common failure modes listed in standards such as IEC 61508 and ISO 26262, the ratio of sub-circuit function size and complexity and from best engineering judgment.

The failure modes listed in this section reflect random failure events and do not include failures due to misuse or overstress.

Table 3-1. Die Failure Modes and Distribution

Die Failure Modes	Failure Mode Distribution (%)
Driver HIZ no output	18%
Output functional – out of specification timing or voltage	27%
Driver stuck at fault high	21%
Driver stuck at fault low	24%
Driver stuck at undetermined state	10%

4 Pin Failure Mode Analysis (Pin FMA)

This section provides a failure mode analysis (FMA) for the pins of the SN74AVC4T774-Q1 (TSSOP and VQFN packages). The failure modes covered in this document include the typical pin-by-pin failure scenarios:

- Pin short-circuited to ground (see [Table 4-2](#))
- Pin open-circuited (see [Table 4-3](#))
- Pin short-circuited to an adjacent pin (see [Table 4-4](#))
- Pin short-circuited to supply (see [Table 4-5](#) and [Table 4-6](#))

[Table 4-2](#) through [Table 4-6](#) also indicate how these pin conditions can affect the device as per the failure effects classification in [Table 4-1](#).

Table 4-1. TI Classification of Failure Effects

Class	Failure Effects
A	Potential device damage that affects functionality
B	No device damage, but loss of functionality
C	No device damage, but performance degradation
D	No device damage, no impact to functionality or performance

[Figure 4-1](#), [Figure 4-2](#), and [Figure 4-3](#) show the SN74AVC4T774-Q1 pin diagrams for the TSSOP, VQFN, and UQFN packages. For a detailed description of the device pins, see the *Pin Configuration and Functions* section in the SN74AVC4T774-Q1 data sheet.

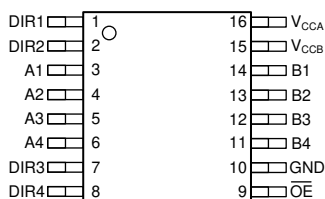

Figure 4-1. Pin Diagram (TSSOP) Package

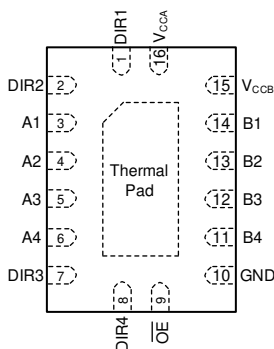

Figure 4-2. Pin Diagram (VQFN Package)

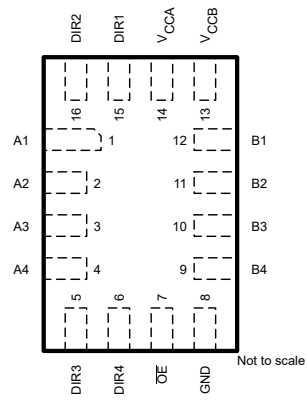

Figure 4-3. Pin Diagram (UQFN Package)

Table 4-2. Pin FMA for Device Pins Short-Circuited to Ground

Pin Name	Pin No.	Description of Potential Failure Effects	Failure Effect Class
DIR1	1	Direction control will fix B --> A direction	B
DIR2	2		
A1	3	If configured as an output then damage is possible. If configured as input, no damage, but output will not switch	A
A2	4		
A3	5		
A4	6		
DIR3	7	Direction control will fix B --> A direction	B
DIR4	8		
OE	9	All outputs will be active, device cannot be disabled	B
GND	10	Normal operation	D
B4	11	If configured as an output then damage is possible. If configured as an input, no damage occurs, but output will not switch	A
B3	12		
B2	13		
B1	14		
VCCB	15	GND short to VCC, device will be bypassed; may cause system damage, but no damage to the device.	B
VCCA	16		

Table 4-3. Pin FMA for Device Pins Open-Circuited

Pin Name	Pin No.	Description of Potential Failure Effect(s)	Failure Effect Class
VCCA	16	GND short to VCC, device will be bypassed; can cause system damage, but not device damage	B
GND	10	Device will not be powered	B
A	3-6	If configured as output, normal operation. If configured as input, pin is floating which could cause excessive current	A
B	11-14	If configured as output, normal operation. If configured as input, pin is floating which could cause excessive current.	A
DIR	1-2 7-8	Pin is floating which can cause excessive current	A
VCCB	15	GND short to VCC, device will be bypassed; can cause system damage, but no damage to the device.	B

Table 4-4. Pin FMA for Device Pins Short-Circuited to Adjacent Pin

Pin Name	Pin No.	Shorted to	Description of Potential Failure Effects	Failure Effect Class
DIR1	1	DIR2	If both HIGH, direction control will fix A --> B direction. If both LOW, direction control will fix B --> A direction. If one DIR is HIGH and the other is LOW, bus contention during transitions can occur and may cause high current	A
DIR2	2	A1	If DIR2 is LOW, A2 will be an output and damage is possible. If DIR3 is HIGH, A2 will be an input and drive the output B2 LOW	A
A1	3	A2	If A(n) and A(n+1) are configured as outputs then damage is possible. If configured as inputs, both bits will always have the same value	A
A2	4	A3		
A3	5	A4		
A4	6	DIR3	If DIR3 is LOW, A3 will be an output and damage is possible. If DIR3 is HIGH, A3 will be an input and drive the output B3 LOW	A
DIR3	7	DIR4	If both HIGH, direction control will fix A --> B direction. If both LOW, direction control will fix B --> A direction. If one DIR is HIGH and the other is LOW, bus contention during transitions could occur and may cause high current	A
DIR4	8	OE	If OE is HIGH, I/Os will be placed in Hi-Z. If both DIR and OE are LOW, direction control will fix B --> A direction. If DIR is HIGH and the OE is LOW, direction control will fix A --> B direction.	B
OE	9	GND	All outputs will be active; device cannot be disabled	B
GND	10	B4	If B4 is configured as an output then damage is possible. If configured as input, output A4 will be fixed LOW	A
B4	11	B3	If B(n) and B(n+1) are configured as outputs then damage is possible. If configured as inputs, both bits will always have the same value.	A
B3	12	B2		
B2	13	B1		
B1	14	VCCB	If B1 is configured as an output then damage is possible. If configured as input, no damage, but output A1 will remain high.	A
VCCB	15	VCCA	GND short to VCC, device will be bypassed; may cause system damage, but not device damage	B
VCCA	16	DIR1	Direction control will fix A --> B direction	B

Table 4-5. Pin FMA for Device Pins Short-Circuited to VCCA

Pin Name	Pin No.	Description of Potential Failure Effect(s)	Failure Effect Class
VCCA	16	Normal operation	D
GND	10	GND short to VCC, device will be bypassed; may cause system damage, but not device damage	B
A	3-6	If configured as an output then damage is possible. If configured as input, no damage, but output will not switch	A
B	11-14	If configured as an output then damage is possible. If configured as input, damage is possible if VIH/VIL is not met	A
DIR	1-2, 7-8	Direction control will fix A --> B direction	B
OE	9	I/Os will be placed in Hi-Z	B
VCCB	15	VCCA short to VCCB, device will be bypassed; may cause system damage, but not device damage	B

Table 4-6. Pin FMA for Device Pins Short-Circuited to VCCB

Pin Name	Pin No.	Description of Potential Failure Effect(s)	Failure Effect Class
VCCA	16	VCCA short to VCCB, device will be bypassed; can cause system damage, but not device damage	B
GND	10	GND short to VCC, device will be bypassed; can cause system damage, but not device damage	B
A	3-6	If configured as an output then damage is possible. If configured as input, damage is possible if VIH/VIL is not met	A
B	11-14	If configured as an output, then damage is possible. If configured as an input, no damage occurs, but output will not switch.	A
DIR	1-2, 7-8	If VCCB > VCCA, DIR will fix B --> A direction OR if VCCB < VCCA, input can be at an inappropriate logic level, which can cause damage	B
OE	9	I/Os will be placed in Hi-Z	B
VCCB	15	Normal operation	D

IMPORTANT NOTICE AND DISCLAIMER

TI PROVIDES TECHNICAL AND RELIABILITY DATA (INCLUDING DATA SHEETS), DESIGN RESOURCES (INCLUDING REFERENCE DESIGNS), APPLICATION OR OTHER DESIGN ADVICE, WEB TOOLS, SAFETY INFORMATION, AND OTHER RESOURCES "AS IS" AND WITH ALL FAULTS, AND DISCLAIMS ALL WARRANTIES, EXPRESS AND IMPLIED, INCLUDING WITHOUT LIMITATION ANY IMPLIED WARRANTIES OF MERCHANTABILITY, FITNESS FOR A PARTICULAR PURPOSE OR NON-INFRINGEMENT OF THIRD PARTY INTELLECTUAL PROPERTY RIGHTS.

These resources are intended for skilled developers designing with TI products. You are solely responsible for (1) selecting the appropriate TI products for your application, (2) designing, validating and testing your application, and (3) ensuring your application meets applicable standards, and any other safety, security, regulatory or other requirements.

These resources are subject to change without notice. TI grants you permission to use these resources only for development of an application that uses the TI products described in the resource. Other reproduction and display of these resources is prohibited. No license is granted to any other TI intellectual property right or to any third party intellectual property right. TI disclaims responsibility for, and you will fully indemnify TI and its representatives against, any claims, damages, costs, losses, and liabilities arising out of your use of these resources.

TI's products are provided subject to [TI's Terms of Sale](#) or other applicable terms available either on [ti.com](https://www.ti.com) or provided in conjunction with such TI products. TI's provision of these resources does not expand or otherwise alter TI's applicable warranties or warranty disclaimers for TI products.

TI objects to and rejects any additional or different terms you may have proposed.

Mailing Address: Texas Instruments, Post Office Box 655303, Dallas, Texas 75265
Copyright © 2024, Texas Instruments Incorporated