

TPS65177/A Fully I²C Programmable 6-CH LCD Bias IC for all Size TV Including Gate Pulse Modulation

1 Features

- Enable / Disable
 - TPS65177: V_I power cycle
 - TPS65177A: V_I power cycle or EN-pin
- 8.6-V to 14.7-V Input Voltage Range
- Non-Synchronous Boost Converter ($V_{(AVDD)}$)
 - Integrated Isolation Switch
 - 13.5-V to 19.8-V Output Voltage (I²C)
 - 15-V Default Output Voltage
 - 4.25-A Switch Current Limit (I²C)
 - High Voltage Stress Mode (I²C)
- Synchronous Buck Converter ($V_{(HAVDD)}$)
 - 4.8-V to 11.1-V Output Voltage (I²C)
 - 7.5-V Default Output Voltage
 - 1.7-A Switch Current Limit
 - High Voltage Stress Mode (I²C)
- Non-Synchronous Buck Converter ($V_{(IO)}$)
 - 2.2-V to 3.7-V Output Voltage (I²C)
 - 2.5-V Default Output Voltage
 - 3-A Switch Current Limit
- Synchronous Buck Converter ($V_{(CORE)}$)
 - 0.8-V to 3.3-V Output Voltage (I²C)
 - 1-V Default Output Voltage
 - 2.5-A Switch Current Limit
- Positive Charge-Pump Controller ($V_{(GH)}$)
 - 20-V to 40-V Output Voltage (I²C)
 - 28-V Default Output Voltage
 - Temp. Compensation Offset 0-V to 15-V (I²C)
 - 4-V Default Offset (28 V to 32 V)
- Negative Charge-Pump Controller ($V_{(GL)}$)
 - –14.5-V to –5.5-V Output Voltage (I²C)
 - –7.9-V Default Output Voltage
- Gate Pulse Modulation (GPM)
 - Down to 0-V, 5-V, 10-V or 15-V (I²C)
 - 0-V Default Discharge Voltage
- Temperature Compensation for $V_{(GH)}$
- Thermal Shutdown
- I²C Compatible Interface
- EEPROM Memory
- 6-mm × 6-mm × 1-mm 40-Pin VQFN Package

2 Applications

- GIP (Gate-in-Panel) LCD TVs
- Non-GIP LCD TVs

3 Description

The TPS65177/A provides all supply rails needed by a GIP (Gate-in-Panel) or non-GIP TFT-LCD panel. All output voltages are I²C programmable.

$V_{(IO)}$ and $V_{(CORE)}$ for the T-CON, $V_{(AVDD)}$ and $V_{(HAVDD)}$ for the Source Driver and the Gamma Buffer, $V_{(GH)}$ and $V_{(GL)}$ for the Gate Driver or the Level Shifter. For use with non-GIP technology Gate Pulse Modulation (GPM) is implemented, for use with GIP technology the $V_{(GH)}$ rail can be temperature compensated. Furthermore a High Voltage Stress Mode (HVS) for $V_{(AVDD)}$ and $V_{(HAVDD)}$ and an integrated $V_{(AVDD)}$ Isolation Switch is implemented. $V_{(CORE)}$, $V_{(HAVDD)}$, $V_{(GH)}$, $V_{(GL)}$, GPM and the $V_{(GH)}$ temperature compensation can be enabled and disabled by I²C programming.

A single BOM (Bill of Materials) can cover several panel types and sizes whose desired output voltage levels can be programmed in production and stored in a non-volatile integrated memory.

Device Information⁽¹⁾

PART NUMBER	PACKAGE	BODY SIZE (NOM)
TPS65177	VQFN (40 Pin)	6.00 mm x 6.00 mm
TPS65177A	VQFN (40 Pin)	6.00 mm x 6.00 mm

(1) For all available packages, see the orderable addendum at the end of the data sheet.

Block Diagram

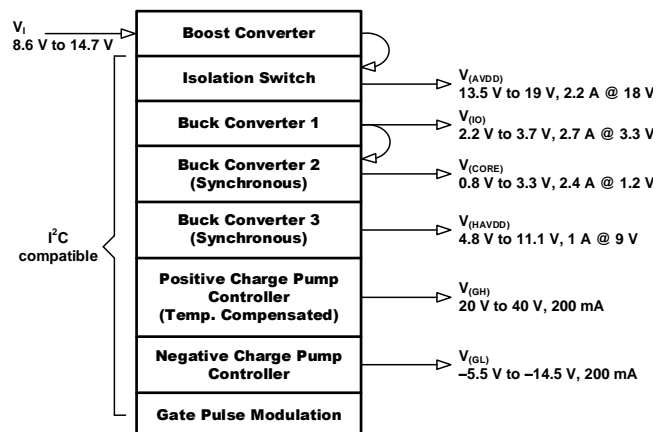

5 Pin Configuration and Functions

RHA Package
40 Pin (VQFN)
Top View

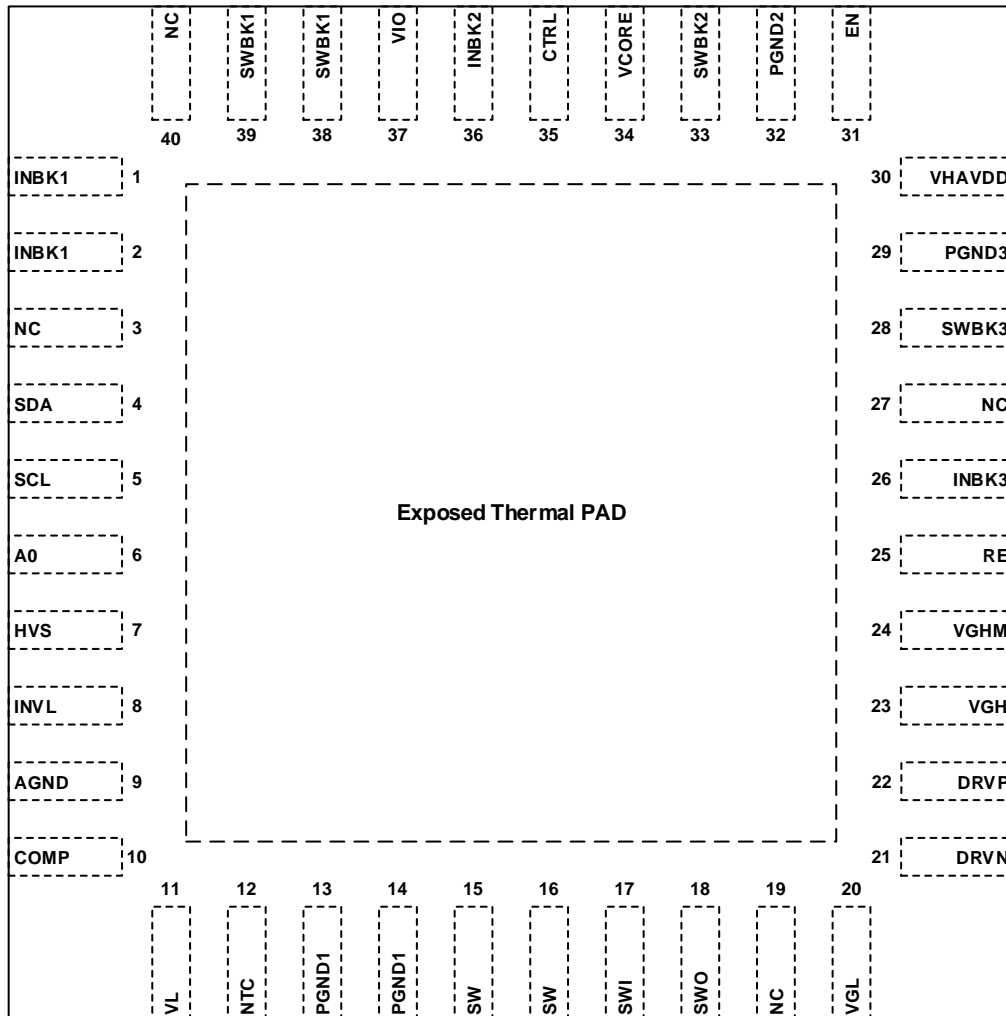

Pin Functions

PIN		TYPE	DESCRIPTION
NAME	NO.		
INBK1	1, 2	—	Buck 1 converter ($V_{(IO)}$) supply pin. This pin is internally connected to INBK3. Place a buffer capacitor close to this pin.
NC	3	—	Not connected.
SDA	4	I / O	I ² C data pin.
SCL	5	I	I ² C clock pin.
A0	6	I	I ² C address select pin.
HVS	7	I	Boost and Buck 3 converter High Voltage Stress Mode enable pin.
INVL	8	—	Internal logic supply pin. Place a buffer capacitor close to this pin.
AGND	9	—	Analog Ground pin. Internal circuitry uses this ground.
COMP	10	I / O	Boost converter ($V_{(AVDD)}$) compensation pin.
VL	11	I / O	Internal 5 V regulator output pin. Connect a buffer capacitor to this pin.
NTC	12	I	Thermal Resistor sense pin.

Pin Functions (continued)

PIN		TYPE	DESCRIPTION
NAME	NO.		
PGND1	13, 14	—	Boost converter ($V_{(AVDD)}$) Power Ground pin.
SW	15, 16	O	Boost converter ($V_{(AVDD)}$) switch pin. Avoid long traces to the diode and inductor because this trace carries switching waveforms that generate noise.
SWI	17	I	Isolation Switch input pin.
SWO	18	O	Isolation Switch output pin.
NC	19	—	Not connected.
VGL	20	I	Negative Charge Pump ($V_{(GL)}$) voltage sense pin.
DRVN	21	O	Negative Charge Pump ($V_{(GL)}$) base drive pin.
DRVP	22	I	Positive charge pump ($V_{(GH)}$) base drive pin.
VGH	23	I	Positive charge pump ($V_{(GH)}$) output voltage sense and Gate Pulse Modulation supply pin.
VGHM	24	I / O	Gate Pulse Modulation output pin.
RE	25	O	Slope adjustment of Gate Pulse Modulation.
INBK3	26	—	Buck 3 converter ($V_{(HAVDD)}$) supply pin. This pin is internally connected to INBK1. Place a buffer capacitor close to this pin.
NC	27	—	Not connected.
SWBK3	28	O	Buck 3 Converter ($V_{(HAVDD)}$) switch pin. Avoid long traces to the inductor because this trace carries switching waveforms that generate noise.
PGND3	29	—	Buck 3 Converter ($V_{(HAVDD)}$) Power Ground pin.
VHAVDD	30	I	Buck 3 Converter ($V_{(HAVDD)}$) voltage sense pin.
EN	31	I	Enable of Isolation Switch, Boost converter and Buck 3 converter.
PGND2	32	—	Buck 2 converter ($V_{(CORE)}$) Power Ground pin.
SWBK2	33	O	Buck 2 converter ($V_{(CORE)}$) switch pin. Avoid long traces to the inductor because this trace carries switching waveforms that generate noise.
VCORE	34	I	Buck 2 converter ($V_{(CORE)}$) output voltage sense pin.
CTRL	35	I	Gate Pulse Modulation control pin.
INBK2	36	—	Buck 2 converter ($V_{(CORE)}$) supply pin. Place a buffer capacitor close to this pin.
VIO	37	I	Buck 1 converter ($V_{(IO)}$) output voltage sense pin.
SWBK1	38, 39	O	Buck 1 converter ($V_{(IO)}$) switch pin. Avoid long traces to the diode and inductor because this trace carries switching waveforms that generate noise.
NC	40	—	Not connected.
Exposed thermal pad		—	The Exposed thermal pad is connected to AGND.

6 Specifications

6.1 Absolute Maximum Ratings

over operating free-air temperature range (unless otherwise noted) ⁽¹⁾

		VALUE		UNIT
		MIN	MAX	
Pin Voltage ⁽²⁾	VIO, INBK1, HVS, INVL, INBK3, SWBK3, VHAVDD, SW, SWI, SWO	-0.3	20	V
	SWBK1	-2	18	V
	COMP, EN, A0, SDA, SCL, CTRL, SWBK2, VCORE, INBK2, DRVN, NTC	-0.3	7	V
	VL	-0.3	5.5	V
	DRVP, VGH, VGHM, RE	-0.3	40	V
	VGL	-15	0.3	V
Operating junction temperature range		-40	150	°C
Storage temperature range, T _{stg}		-65	150	°C

- (1) Stresses beyond those listed under “absolute maximum ratings” may cause permanent damage to the device. These are stress ratings only and functional operation of the device at these or any other conditions beyond those indicated under “recommended operating conditions” is not implied. Exposure to absolute-maximum-rated conditions for extended periods may affect device reliability.
- (2) With respect to the GND pin.

6.2 ESD Ratings

		VALUE		UNIT
		MIN	MAX	
V _(ESD) Electrostatic discharge	Human-body model (HBM), per ANSI/ESDA/JEDEC JS-001 ⁽¹⁾	±2000		V
	Charged-device model (CDM), per JEDEC specification JESD22-C101 ⁽²⁾	±700		

- (1) JEDEC document JEP155 states that 500-V HBM allows safe manufacturing with a standard ESD control process.
- (2) JEDEC document JEP157 states that 250-V CDM allows safe manufacturing with a standard ESD control process.

6.3 Recommended Operating Conditions

over operating free-air temperature range (unless otherwise noted)

		MIN	TYP	MAX	UNIT
V_I	Supply input voltage range	8.6	12	14.7	V
$C_{(VL)}$	Internal 5 V regulator (VL) buffer capacitance (after DC-Bias derating)	0.1	1	4.7	μF
BOOST CONVERTER					
$V_{(AVDD)}$	Boost output voltage range	13.5		19.8	V
L	Boost inductor (inductor value that can be used)	4.7	6.8	10	μH
C_1	Input capacitor placed at the inductor (ceramic capacitor value)	4.7	10		μF
$C_{(SWI)}$	Isolation Switch input capacitor (ceramic capacitor value)	4.7	10	100	μF
$C_{(SWO)}$	Isolation Switch output capacitor (ceramic capacitor value)	20	40	200	μF
BUCK 1 CONVERTER					
$V_{(IO)}$	Buck 1 output voltage range	2.2		3.7	V
L	Buck 1 inductor (inductor value that can be used)	4.7	6.8	10	μH
C_1	Buck 1 input capacitor (ceramic capacitor value)	4.7	10		μF
C_{OUT}	Buck 1 output capacitor (ceramic capacitor value)	20	30	100	μF
BUCK 2 CONVERTER					
$V_{(CORE)}$	Buck 2 output voltage range	0.8		3.3	V
L	Buck 2 inductor (inductor value that can be used)	4.7	6.8	10	μH
C_1	Buck 2 input capacitor (ceramic capacitor value)	4.7	10		μF
C_{OUT}	Buck 2 output capacitor (ceramic capacitor value)	10	20	50	μF
BUCK 3 CONVERTER					
$V_{(HAVDD)}$	Buck 3 output voltage range	4.8		11.1	V
L	Buck 3 inductor (inductor value that can be used)	4.7	6.8	10	μH
C_{IN}	Buck 3 input capacitor (ceramic capacitor value)	4.7	10		μF
C_{OUT}	Buck 3 output capacitor (ceramic capacitor value)	4.7	10	50	μF
NEGATIVE CHARGE PUMP CONTROLLER					
$V_{(GL)}$	Controller output voltage range	-5.5		-14.5	V
$C_{(FLY)}$	Flying capacitor (ceramic capacitor value)	0.1	0.47	4.7	μF
$R_{(switch)}$	Resistance to the switch pin	0	2.2	20	Ω
C_{OUT}	Output capacitor (ceramic capacitor value)	1	4.7	50	μF
POSITIVE CHARGE PUMP CONTROLLER					
$V_{(GH)}$	Controller output voltage range	20		40	V
$V_{(GH_offset)}$	Temperature compensation $V_{(GH)}$ positive offset	0		15	V
$C_{(FLY)}$	Flying capacitor (ceramic capacitor value)	0.1	0.47	4.7	μF
$R_{(switch)}$	Resistance to the switch pin	0	2.2	20	Ω
C_{OUT}	Output capacitor (ceramic capacitor value)	1	4.7	50	μF
TEMPERATURE					
T_A	Operating ambient temperature	-40		85	$^{\circ}\text{C}$
T_J	Operating junction temperature	-40		125	$^{\circ}\text{C}$

6.4 Thermal Information

	THERMAL METRIC ⁽¹⁾	RHA (VQFN)	UNIT
		40 PINS	
$R_{\theta JA}$	Junction-to-ambient thermal resistance	32.8	$^{\circ}\text{C}/\text{W}$
$R_{\theta JC(top)}$	Junction-to-case (top) thermal resistance	20.3	$^{\circ}\text{C}/\text{W}$
$R_{\theta JB}$	Junction-to-board thermal resistance	7.9	$^{\circ}\text{C}/\text{W}$
Ψ_{JT}	Junction-to-top characterization parameter	0.3	$^{\circ}\text{C}/\text{W}$
Ψ_{JB}	Junction-to-board characterization parameter	7.8	$^{\circ}\text{C}/\text{W}$
$R_{\theta JC(bot)}$	Junction-to-case (bottom) thermal resistance	2.6	$^{\circ}\text{C}/\text{W}$

(1) For more information about traditional and new thermal metrics, see the *Semiconductor and IC Package Thermal Metrics* application report, [SPRA953](#).

6.5 Electrical Characteristics

$V_I = 12\text{ V}$, $V_{EN} = 3.3\text{ V}$, $V_{(AVDD)} = 18\text{ V}$, $V_{(HAVDD)} = 9\text{ V}$, $V_{(IO)} = 3.3\text{ V}$, $V_{(CORE)} = 1.2\text{ V}$, $V_{(GH)} = 28\text{ V}$, $V_{(GL)} = -10.3\text{ V}$, $T_A = -40^\circ\text{C}$ to 85°C , typical values are at $T_A = 25^\circ\text{C}$ (unless otherwise noted)

PARAMETER		TEST CONDITIONS	MIN	TYP	MAX	UNIT
SUPPLY CURRENT						
V_I	Operating input voltage		8.6		14.7	V
V_{IT+}	Undervoltage lockout threshold (UVLO)	V_I rising	8	8.3	8.6	V
V_{IT-}		Hysteresis V_I falling		0.75		V
	Thermal shutdown	Junction temperature rising		150		$^\circ\text{C}$
LOGIC SIGNALS						
V_{IH}	High-level input voltage	EN, HVS, SDA, SCL, A0, CTRL	2			V
V_{IL}	Low-level input voltage	EN, HVS, A0, CTRL			1	V
		SDA, SCL			0.9	V
INTERNAL REGULATOR						
$V_{(VL)}$	Internal supply		4.9	5	5.1	V
ISOLATION SWITCH						
$r_{DS(ON)}$	MOSFET on-resistance	$I_{(SWI)} = 1\text{ A}$		100		m Ω
BOOST CONVERTER ($V_{(AVDD)}$)						
	Switching frequency		600	750	900	kHz
$V_{(AVDD)}$	Output voltage range		13.5	18	19	V
	Output voltage range for max. 500h				19.8	V
	High Voltage Stress Mode $V_{(AVDD)}$ positive offset		0		3	V
	Switch overvoltage protection	At SW pin, $V_{(AVDD)}$ rising	20.5		22.5	V
	Output voltage tolerance	At $T_J = 0^\circ\text{C}$ to 85°C			1%	
	Feedback input bias current			350	600	μA
$r_{DS(on)}$	MOSFET on-resistance	$I_{(SW)} = \text{current limit}$		100	200	m Ω
	MOSFET current limit	At $T_J = 0^\circ\text{C}$ to 85°C	4.25	5	5.75	A
	MOSFET current limit negative offset		0		2.8	A
	Line Regulation	$8.6\text{ V} \leq V_I \leq 14.7\text{ V}$, $I_{OUT} = 500\text{ mA}$		0.001		%/V
	Load Regulation	$1\text{ mA} \leq I_{OUT} \leq 2\text{ A}$		0.08		%/A
BUCK1 CONVERTER ($V_{(IO)}$)						
	Switching frequency		600	750	900	kHz
$V_{(IO)}$	Output voltage range		2.2	3.3	3.7	V
	Output voltage tolerance	At $T_J = 0^\circ\text{C}$ to 85°C			2%	
I	Feedback input bias current			10	200	μA
$r_{DS(on)}$	MOSFET on-resistance	$I_{(SWBK1)} = \text{current limit}$		200	300	m Ω
	MOSFET current limit	At $T_J = 0^\circ\text{C}$ to 85°C	2.8	3.5	4.2	A
	Line Regulation	$8.6\text{ V} \leq V_I \leq 14.7\text{ V}$, $I_{OUT} = 500\text{ mA}$		0.002		%/V
	Load Regulation	$1\text{ mA} \leq I_{OUT} \leq 2\text{ A}$		0.07		%/A
BUCK2 CONVERTER ($V_{(CORE)}$)						
	Switching frequency		0.5	1	2	MHz
$V_{(CORE)}$	Output voltage range		0.8	1.2	3.3	V
	Output voltage tolerance	At $T_J = 0^\circ\text{C}$ to 85°C			2%	
	Feedback input bias current			20	200	μA
$r_{DS(on)}$	MOSFET on-resistance	$I_{(SWBK2)} = \text{current limit}$		175	300	m Ω
	MOSFET current limit	At $T_J = 0^\circ\text{C}$ to 85°C	2.5	3	3.5	A
	Line Regulation	$2.2\text{ V} \leq V_I \leq 3.7\text{ V}$, $I_{OUT} = 500\text{ mA}$		0.001		%/V
	Load Regulation	$1\text{ mA} \leq I_{OUT} \leq 1.5\text{ A}$		0.2		%/A

Electrical Characteristics (continued)

$V_I = 12\text{ V}$, $EN = 3.3\text{ V}$, $V_{(AVDD)} = 18\text{ V}$, $V_{(HAVDD)} = 9\text{ V}$, $V_{(IO)} = 3.3\text{ V}$, $V_{(CORE)} = 1.2\text{ V}$, $V_{(GH)} = 28\text{ V}$, $V_{(GL)} = -10.3\text{ V}$, $T_A = -40^\circ\text{C}$ to 85°C , typical values are at $T_A = 25^\circ\text{C}$ (unless otherwise noted)

PARAMETER		TEST CONDITIONS	MIN	TYP	MAX	UNIT
BUCK3 CONVERTER ($V_{(HAVDD)}$)						
	Switching frequency		0.5	1	2	MHz
$V_{(HAVDD)}$	Output voltage range		4.8	9	11.1	V
	Output Voltage Stress Mode $V_{(HAVDD)}$ positive offset		0		1.5	V
	Output voltage tolerance	At $T_J = 0^\circ\text{C}$ to 85°C			1.5%	
	Feedback input bias current			90	200	μA
$r_{DS(on)}$	MOSFET on-resistance	$I_{(SWBK3)} = \text{current limit}$		300	500	m Ω
	MOSFET current limit	At $T_J = 0^\circ\text{C}$ to 85°C	1.2	1.5	1.8	A
	Line Regulation	$8.6\text{ V} \leq V_I \leq 14.7\text{ V}$, $I_{OUT} = 500\text{ mA}$		0.002		%/V
	Load Regulation	$1\text{ mA} \leq I_{OUT} \leq 1\text{ A}$		0.05		%/A
NEGATIVE CHARGE PUMP CONTROLLER ($V_{(GL)}$)						
$V_{(GL)}$	Output voltage range		-5.5	-10.3	-14.5	V
	Output voltage tolerance	At $T_J = 0^\circ\text{C}$ to 85°C			2.5%	
	Feedback input bias current			50	200	μA
$I_{(DRVN)}$	Max. DRVN drive current	$V_{(DRVN)} = 0.6\text{ V}$	5		10	mA
	Resistor DRVN to GND		50	100	200	k Ω
	Line Regulation	$8.6\text{ V} \leq V_I \leq 14.7\text{ V}$, $I_{OUT} = 50\text{ mA}$		0.015		%/V
	Load Regulation	$1\text{ mA} \leq I_{OUT} \leq 100\text{ mA}$		0.002		%/mA
POSITIVE CHARGE PUMP CONTROLLER ($V_{(GH)}$)						
$V_{(GH)}$	Output voltage range		20	28	35	V
$V_{(GH_offset)}$	Temp. compensation $V_{(GH)}$ positive offset	$V_{(GH_offset)} = 8\text{ V}$	0	8	15	V
	Max. output voltage including $V_{(GH_offset)}$				40	V
	Output voltage tolerance	At $T_J = 0^\circ\text{C}$ to 85°C			2.5%	
	Feedback input bias current			120	200	μA
$I_{(DRVP)}$	Max. DRVP drive current	$V_{(DRVP)} = 17\text{ V}$	5		10	mA
	Line Regulation	$8.6\text{ V} \leq V_I \leq 14.7\text{ V}$, $I_{OUT} = 50\text{ mA}$		0.001		%/V
	Load Regulation	$1\text{ mA} \leq I_{OUT} \leq 100\text{ mA}$		0.001		%/mA
GATE PULSE MODULATION ($V_{(GHM)}$)						
	Gate Pulse Modulation falling limit	$V_{(GHM)} = 15\text{ V}$	0	5	15	V
$r_{DS(ON)M1}$	VGH to VGHM on-resistance	CTRL = 3.3 V, $I_{(VGHM)} = 20\text{ mA}$, $V_{(GH)} = 28\text{ V}$		3	5	Ω
$r_{DS(ON)M2}$	VGHM to RE on-resistance	CTRL = GND, $I_{(RE)} = 20\text{ mA}$, $V_{(GHM)} = 15\text{ V}$		3	5	Ω
	CTRL to VGHM propagation delay	CTRL rising	150	250	360	ns

6.6 I²C Interface Timing Characteristics ⁽¹⁾

PARAMETER		TEST CONDITIONS	MIN	TYP	MAX	UNIT
f _{SCL}	SCL clock frequency	Standard mode			100	kHz
		Fast mode			400	kHz
		Fast mode plus			1	MHz
t _{LOW}	LOW period of the SCL clock	Standard mode	4.7			μs
		Fast mode	1.3			μs
t _{HIGH}	HIGH period of the SCL clock	Standard mode	4.0			μs
		Fast mode	600			ns
t _{BUF}	Bus free time between a STOP and START condition	Standard mode	4.7			μs
		Fast mode	1.3			μs
t _{hd:STA}	Hold time for a repeated START condition	Standard mode	4.0			μs
		Fast mode	600			ns
t _{su:STA}	Setup time for a repeated START condition	Standard mode	4.7			μs
		Fast mode	600			ns
t _{su:STO}	Setup time for STOP condition	Standard mode	4.0			μs
		Fast mode	600			ns
t _{hd:DAT}	Data hold time	Standard mode	0		3.45	μs
		Fast mode	0		0.9	μs
t _{su:DAT}	Data setup time	Standard mode	250			ns
		Fast mode	100			ns
C _B	Capacitive load for SDA and SCL				400	pF
t _{RCL1}	Rise time of SCL signal after a repeated START condition and after an acknowledge bit	Standard mode	20 + 0.1C _B		1000	ns
		Fast mode	20 + 0.1C _B		1000	ns
t _{RCL}	Rise time of SCL signal	Standard mode	20 + 0.1C _B		1000	ns
		Fast mode	20 + 0.1C _B		300	ns
t _{FCL}	Fall time of SCL signal	Standard mode	20 + 0.1C _B		300	ns
		Fast mode	20 + 0.1C _B		300	ns
t _{RDA}	Rise time of SDA signal	Standard mode	20 + 0.1C _B		1000	ns
		Fast mode	20 + 0.1C _B		300	ns
t _{FDA}	Fall time of SDA signal	Standard mode	20 + 0.1C _B		300	ns
		Fast mode	20 + 0.1C _B		300	ns

(1) Industry standard I²C timing characteristics. Not tested in production.

6.7 I²C Timing Diagram

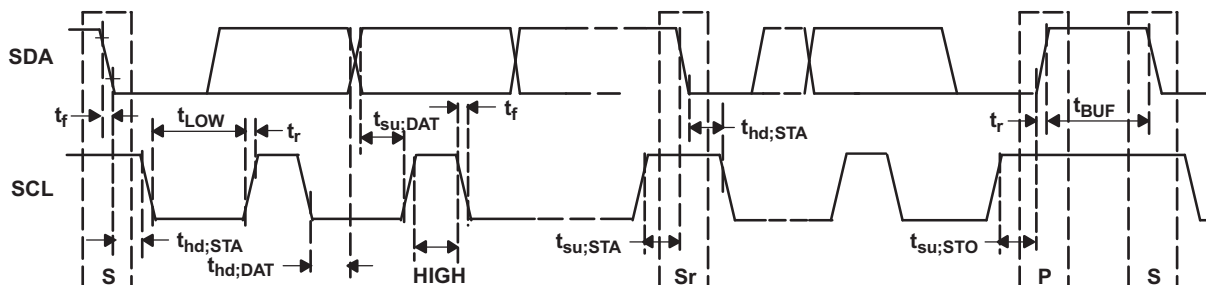

6.8 Typical Characteristics

$V_I = 12\text{ V}$ unless otherwise noted.

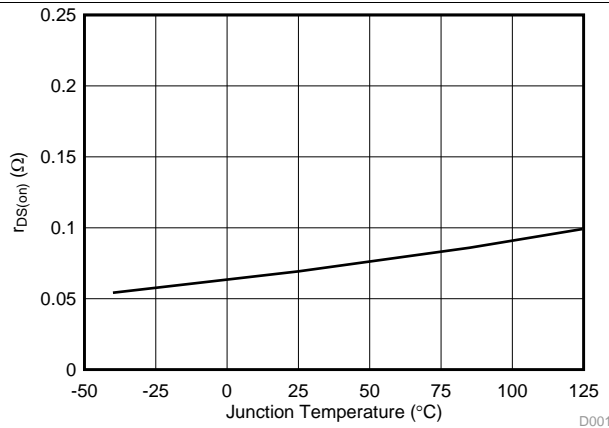

Figure 1. $V_{(AVDD)}$ Boost Converter NMOS $r_{DS(on)}$

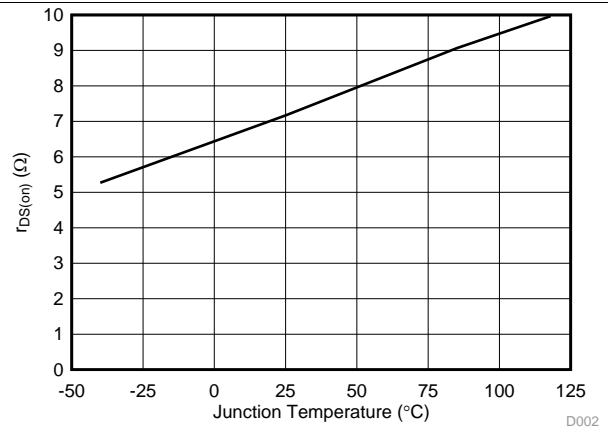

Figure 2. $V_{(AVDD)}$ Boost Converter PMOS $r_{DS(on)}$

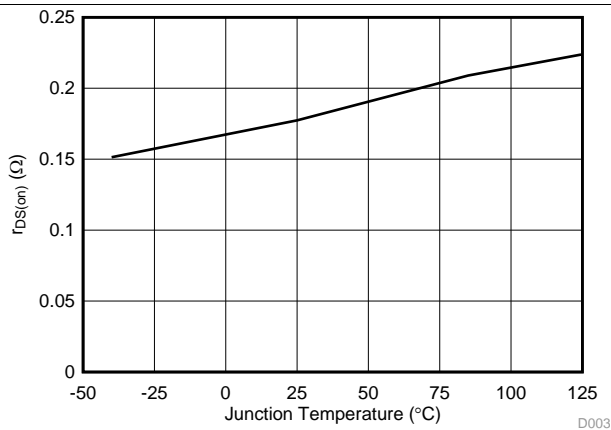

Figure 3. $V_{(IO)}$ Buck 1 Converter NMOS $r_{DS(on)}$

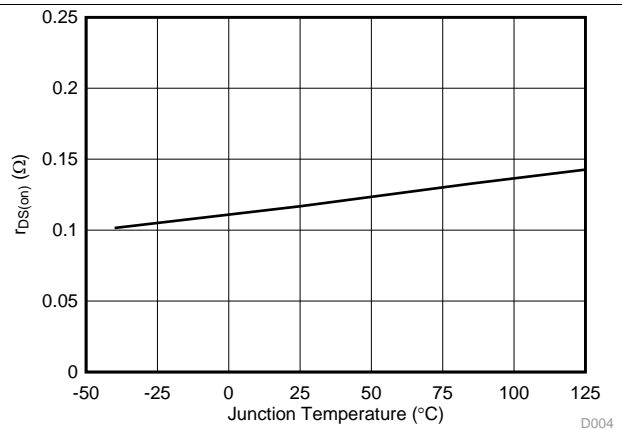

Figure 4. $V_{(CORE)}$ Buck 2 Converter NMOS $r_{DS(on)}$

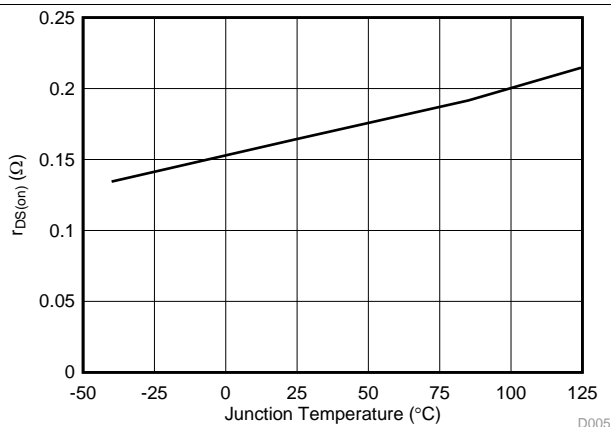

Figure 5. $V_{(CORE)}$ Buck 2 Converter PMOS $r_{DS(on)}$

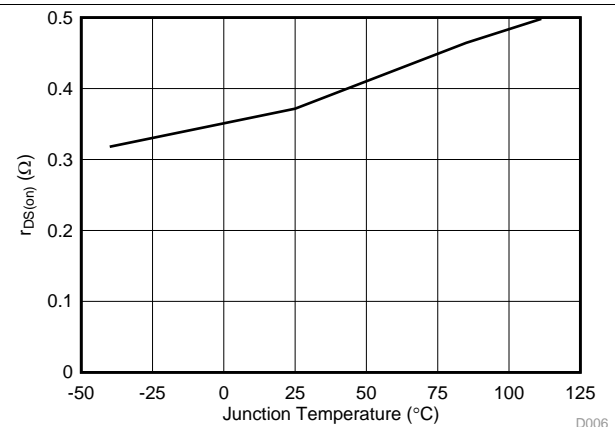

Figure 6. $V_{(HAVDD)}$ Buck 3 Converter NMOS $r_{DS(on)}$

Typical Characteristics (continued)

$V_I = 12\text{ V}$ unless otherwise noted.

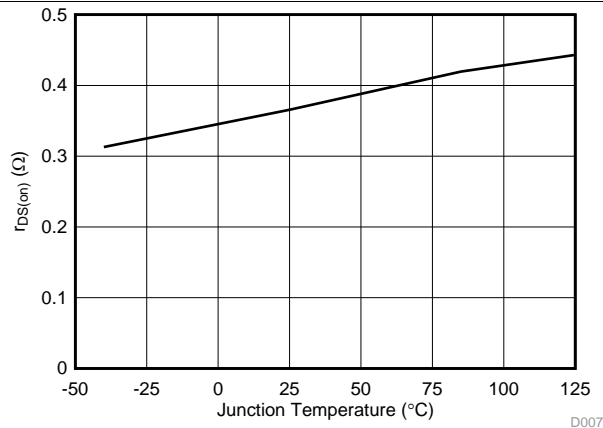

Figure 7. $V_{(HAVDD)}$ Buck 3 Converter PMOS $r_{DS(on)}$

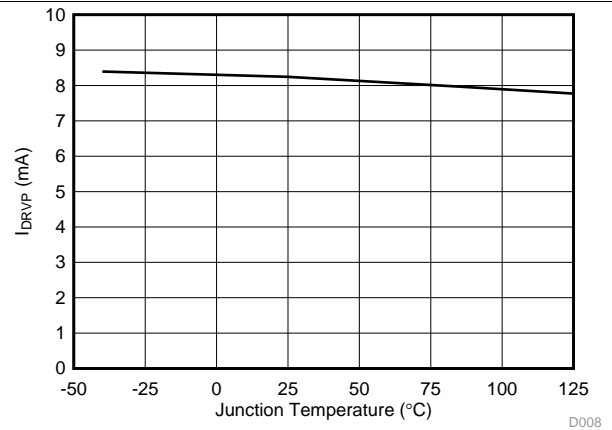

Figure 8. $V_{(GH)}$ charge-pump DRVP drive current

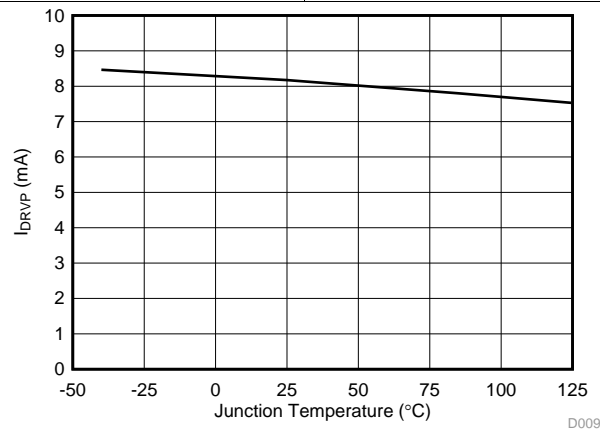

Figure 9. $V_{(GL)}$ charge-pump DRVN drive current

7 Detailed Description

7.1 Overview

The TPS65177/A provides all supply rails needed by a GIP (Gate-in-Panel) or non-GIP TFT-LCD panel. All output voltages are I²C programmable.

$V_{(IO)}$ and $V_{(CORE)}$ for the T-CON, $V_{(AVDD)}$ and $V_{(HAVDD)}$ for the Source Driver and the Gamma Buffer, $V_{(GH)}$ and $V_{(GL)}$ for the Gate Driver or the Level Shifter. For use with non-GIP technology Gate Pulse Modulation (GPM) is implemented, for use with GIP technology the $V_{(GH)}$ rail can be temperature compensated. Furthermore a High Voltage Stress Mode (HVS) for $V_{(AVDD)}$ and $V_{(HAVDD)}$ and an integrated $V_{(AVDD)}$ Isolation Switch is implemented. $V_{(CORE)}$, $V_{(HAVDD)}$, $V_{(GH)}$, $V_{(GL)}$, GPM and the $V_{(GH)}$ temperature compensation can be enabled and disabled by I²C programming.

A single BOM (Bill of Materials) can cover several panel types and sizes whose desired output voltage levels can be programmed in production and stored in a non-volatile integrated memory.

7.2 Functional Block Diagram

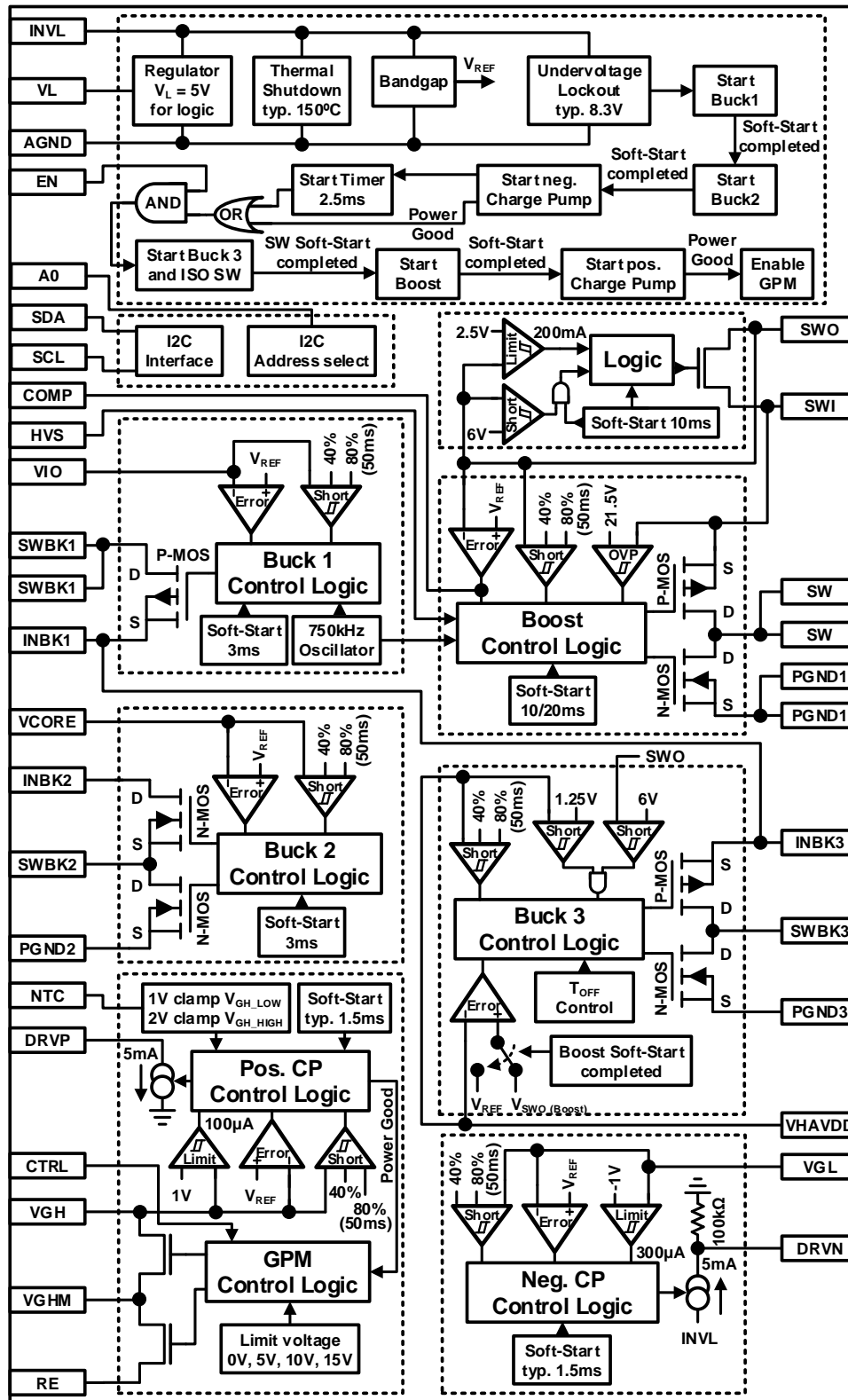

7.3 Feature Description

7.3.1 Power-Up

When V_I rises above the UVLO (undervoltage lockout) the device loads the stored values in the non-volatile Initial Value register into the volatile DAC register. When all data is written the power-up sequencing starts with enabling the buck 1 converter ($V_{(IO)}$), which ramps up its output voltage in 3 ms. When the output is in regulation the buck 2 converter ($V_{(CORE)}$) starts and ramps up its output voltage in 3 ms, when its output voltage is in regulation the negative charge pump controller starts and $V_{(GL)}$ is declining in typ. 1.5 ms until the output voltage is in regulation. In case $V_{(GL)}$ is driven by the boost switch pin (SW) $V_{(GL)}$ starts declining when the boost starts switching.

When the enable pin (EN) is pulled “high” the isolation switch closes smoothly so that after typ. 10 ms its output ($V_{(AVDD)}$) is at V_I level, then the boost converter ($V_{(AVDD)}$) starts and its output voltage ($V_{(AVDD)}$) ramps linearly in 10 ms or 20 ms (programmable by I²C) until it is in regulation. Then the positive charge pump controller starts and $V_{(GH)}$ is rising in typ. 1.5 ms until the output voltage is in regulation. To ensure proper sequencing even if EN is pulled “high” already at the beginning (e.g. connected to V_I) the start of the boost converter $V_{(AVDD)}$ is blocked until $V_{(GL)}$ is Power Good or 2.5 ms have passed since $V_{(GL)}$ was enabled.

If the EN pin is not connected to V_I , the device detects a collapsed $V_{(AVDD)}$ voltage about 40 ms after EN is pulled low. This function prevents the panel to restart without a proper power supply reset. The device partially shuts down as described in the [Short-Circuit and Overload Protection](#) section. The device is in a latched state and only a power cycle can restart the $V_{(AVDD)}$, $V_{(HAVDD)}$, $V_{(GH)}$ and $V_{(GL)}$ rail.

When $V_{(GL)}$ is driven by the boost switch pin (SW) the EN-pin should be connected to V_I , otherwise $V_{(GL)}$ detects a short when EN is pulled low as the $V_{(GL)}$ voltage collapses. $V_{(GL)}$ collapses because the supporting switch node (SW) stops switching and the device partially shuts down as described in the [Short-Circuit and Overload Protection](#) section. The device is in a latched state and only a power cycle can restart the $V_{(AVDD)}$, $V_{(HAVDD)}$, $V_{(GH)}$ and $V_{(GL)}$ rail.

The buck 2 and buck 3 converter as the negative and positive charge pump controller can be disabled by I²C. If disabled they are skipped in the sequencing (e.g. disabled buck 2 → buck 1 is in regulation → start neg. CP).

The Gate Pulse Modulation block is disabled when V_I is below UVLO or EN is “low” and enabled when $V_{(GH)}$ is in regulation. When the block is disabled by UVLO the high side switch of the Gate Pulse Modulation is turned on and the output VGHM is connected to the VGH pin, when the block is disabled by pulling the EN pin “low” the low side switch is turned on and the output VGHM is connected to the RE pin.

7.3.1.1 TPS65177

If the EN pin is not connected to V_I , the device detects a collapsed $V_{(AVDD)}$ voltage about 40 ms after EN is pulled low. This function prevents the panel to restart without a proper power supply reset. The device partially shuts down as described in the [Short-Circuit and Overload Protection](#) section. The device is in a latched state and only a power cycle can restart the $V_{(AVDD)}$, $V_{(HAVDD)}$, $V_{(GH)}$ and $V_{(GL)}$ rail.

7.3.1.2 TPS65177A

The device can be restarted without a power cycle, however note that when $V_{(GL)}$ is driven by the boost switch pin (SW) the EN-pin should be connected to V_I . If the EN-pin is not connected to V_I the $V_{(GL)}$ protection detects a short when EN is pulled low as the $V_{(GL)}$ voltage collapses. $V_{(GL)}$ collapses because the supporting switch node (SW) stops switching and the device partially shuts down as described in the [Short-Circuit and Overload Protection](#) section. The device is in a latched state and only a power cycle can restart the $V_{(AVDD)}$, $V_{(HAVDD)}$, $V_{(GH)}$ and $V_{(GL)}$ rail.

Feature Description (continued)

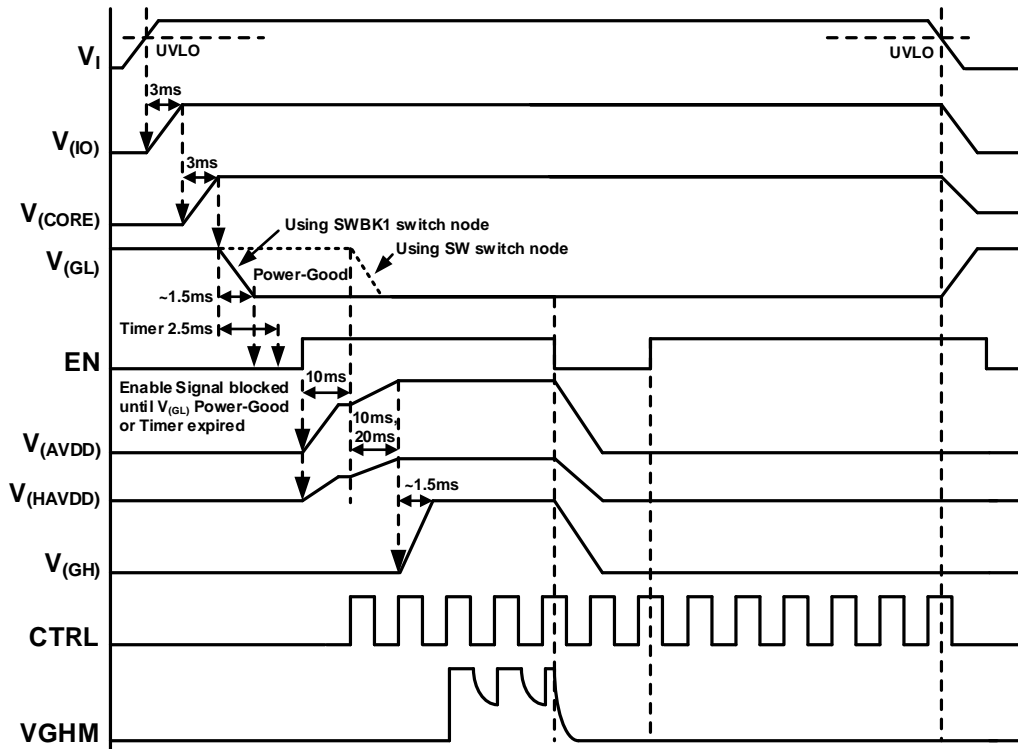

Figure 10. TPS65177 Power-up Sequencing

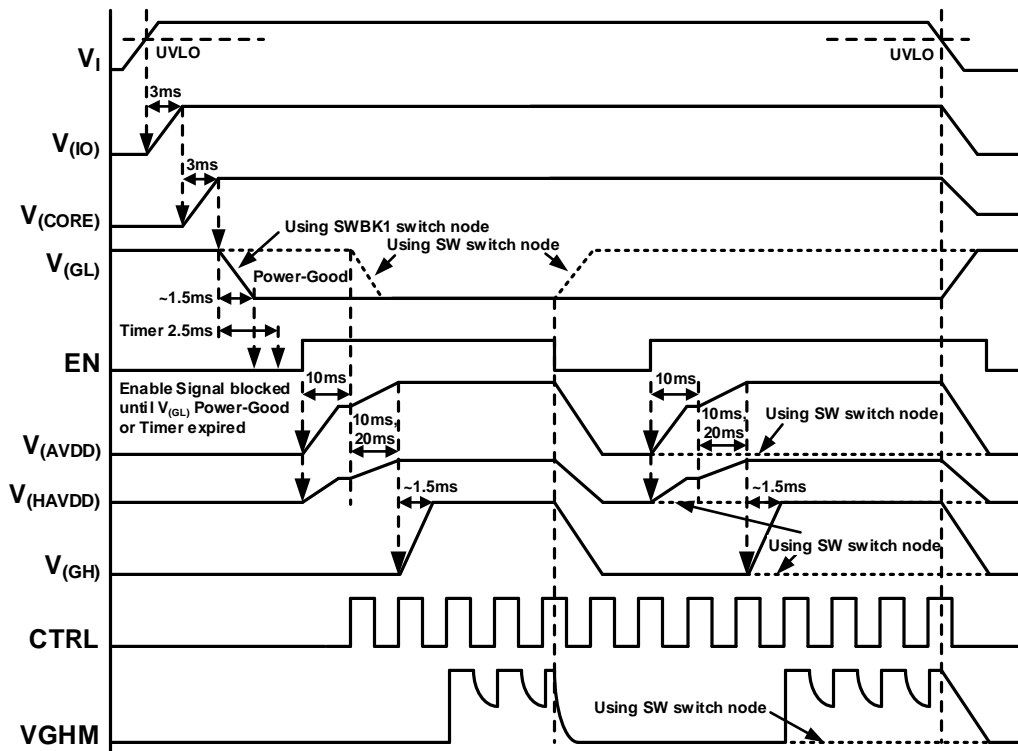

Figure 11. TPS65177A Power-up Sequencing

Feature Description (continued)

7.3.2 Power-Down

When V_I falls below the UVLO threshold all blocks are disabled and the discharge rate is given by the output load and the output capacitors. The Gate Pulse Modulation output $V_{(GHM)}$ follows $V_{(GH)}$.

7.3.3 Thermal Shutdown

A thermal shutdown is implemented to prevent damage because of excessive heat and power dissipation. Once a temperature of typically 150 °C is exceeded the device shuts down and stays off. V_I must fall below Undervoltage lockout threshold (UVLO) to reset the thermal shutdown.

7.3.4 Undervoltage Lockout

To avoid mis-operation of the device at low input voltages an undervoltage lockout is included, which shuts down the device at voltages lower than typically 8.3 V.

7.3.5 Short-Circuit and Overload Protection

7.3.5.1 Boost Converter ($V_{(AVDD)}$):

- | | |
|---|--|
| When $V_{(SWO)} < 40\%$ of its nominal value | → Shut down Boost, Isolation Switch, Buck3, neg. and pos. Charge Pump controller (Buck 1 and Buck 2 keep working)
→ latched condition, only triggering UVLO enables the device again. |
| When $V_{(SWO)} < 80\%$ of its nominal value for longer than 50 ms (overload) | → Shut down Boost, Isolation Switch, Buck3, neg. and pos. Charge Pump controller (Buck 1 and Buck 2 keep working)
→ latched condition, only triggering UVLO enables the device again. |

7.3.5.2 Buck 1 Converter ($V_{(IO)}$):

- | | |
|--|--|
| When $V_{(IO)} < 40\%$ of its nominal value | → Shut down the whole device → latched condition, only triggering UVLO enables the device again. |
| When $V_{(IO)} < 80\%$ of its nominal value for longer than 50 ms (overload) | → Shut down the whole device → latched condition, only triggering UVLO enables the device again. |

7.3.5.3 Buck 2 Converter ($V_{(CORE)}$):

- | | |
|--|--|
| When $V_{(CORE)} < 40\%$ of its nominal value | → Shut down the whole device → latched condition, only triggering UVLO enables the device again. |
| When $V_{(CORE)} < 80\%$ of its nominal value for longer than 50 ms (overload) | → Shut down the whole device → latched condition, only triggering UVLO enables the device again. |

7.3.5.4 Buck 3 Converter ($V_{(HAVDD)}$):

- | | |
|--|--|
| When $V_{(HAVDD)} < 40\%$ of its nominal value | → Shut down Buck3, Isolation Switch, Boost, neg. and pos. Charge Pump controller (Buck 1 and Buck 2 keep working)
→ latched condition, only triggering UVLO enables the device again. |
|--|--|

Feature Description (continued)

When $V_{(HAVDD)} < 80\%$ of its nominal value for longer than 50 ms (overload) → Shut down Buck3, Isolation Switch, Boost, neg. and pos. Charge Pump controller (Buck 1 and Buck 2 keep working) → latched condition, only triggering UVLO enables the device again.

7.3.5.5 Positive Charge-Pump Controller ($V_{(GH)}$):

When $V_{(GH)} < 40\%$ of its nominal value → Shut down pos. Charge Pump, Isolation Switch, Boost, Buck3, neg. Charge Pump controller (Buck1 and Buck2 keep working) → latched condition, only triggering UVLO enables the device again.

When $V_{(GH)} < 80\%$ of its nominal value for longer than 50 ms (overload) → Shut down pos. Charge Pump, Isolation Switch, Boost, Buck3, neg. Charge Pump controller (Buck1 and Buck2 keep working) → latched condition, only triggering UVLO enables the device again.

7.3.5.6 Negative Charge-Pump Controller ($V_{(GL)}$):

When $V_{(GL)} < 40\%$ of its nominal value → Shut down neg. Charge Pump, Isolation Switch, Boost, Buck3, pos. Charge Pump controller (Buck1 and Buck2 keep working) → latched condition, only triggering UVLO enables the device again.

When $V_{(GL)} < 80\%$ of its nominal value for longer than 50 ms (overload) → Shut down neg. Charge Pump, Isolation Switch, Boost, Buck3, pos. Charge Pump controller (Buck1 and Buck2 keep working) → latched condition, only triggering UVLO enables the device again.

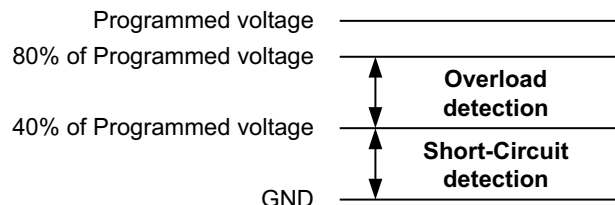

Figure 12. Short-Circuit Levels Overview

7.4 Device Functional Modes

7.4.1 Boost Converter ($V_{(AVDD)}$)

The quasi-synchronous current mode boost converter operates with Pulse Width Modulation (PWM) with a fixed frequency of 750 kHz. For maximum design flexibility and stability with different external components, the converter uses external loop compensation by a simple RC circuit. The converter has an input-to-output switch at the output rail to disconnect its output.

7.4.1.1 Soft-Start

The boost converter is enabled by the EN-pin, the startup is done in two steps:

1. **Input-to-output isolation switch soft-start**
The isolation switch is turned on slowly in 10 ms

2. **Boost converter soft-start**

When the isolation switch is fully turned on (after 10 ms) the boost converter starts switching and ramps up

Device Functional Modes (continued)

its output voltage $V_{(AVDD)}$ from V_I to the programmed voltage value in 10 or 20 ms (programmable by I²C).

7.4.1.2 Compensation

The regulator loop can be compensated by adjusting the external RC circuit connected to the COMP pin. The COMP-pin is the output of the transconductance error amplifier. The compensation capacitor adjusts the low frequency gain and the resistor the high frequency gain. Lower output voltages require a higher gain and therefore a smaller compensation capacitor. A good start working for most applications is $C_{(COMP)} = 470$ pF and $R_{(COMP)} = 75$ k Ω . In case of a high noise level an additional 22-pF capacitor can be put between the COMP-pin and GND to filter the high frequency noise. The cut-off frequency can be calculated as follows:

$$f_z = \frac{1}{2 \times \pi \times R_{COMP} \times C_{COMP}} \quad (1)$$

7.4.1.3 Setting the Output Voltage $V_{(AVDD)}$

The output voltage is programmable by I²C between 13.5 V and 19.8 V in 100 mV steps.

7.4.1.4 High Voltage Stress Mode (HVS)

By pulling the HVS-pin “high” an I²C programmable offset voltage is added to the set boost and buck 3 converters output voltage $V_{(AVDD)}$ and $V_{(HAVDD)}$. The offset voltages are programmable independently.

7.4.1.5 Programmable Current Limit

The current limit of typ. 5 A can be reduced by I²C programming in 400 mA steps down to 2.2 A to support smaller inductors with lower saturation current.

7.4.1.6 Design Procedure

The first step in the design procedure is to verify whether the maximum possible output current of the boost converter supports the specific application requirements.

1. Converter Duty Cycle: $D = 1 - \frac{V_{IN} \times \eta}{V_{AVDD}}$
2. Inductor ripple current: $\Delta I_L = \frac{V_{IN} \times D}{f_s \times L}$
3. Maximum output current: $I_{OUT_max} = \left(I_{LIM_min} - \frac{\Delta I_L}{2} \right) \times (1 - D)$
4. Peak switch current: $I_{SWPEAK} = \frac{I_{OUT}}{1 - D} + \frac{\Delta I_L}{2}$

η = Estimated boost converter efficiency (use the number from the efficiency plots or 0.9 as an estimation)

f_s = Switching frequency (typ. 750 kHz)

L = Selected inductor value (typ. 6.8 μ H)

I_{LIM_min} : Minimum current limit

I_{SWPEAK} = Peak switch current for the used output current (must be < $I_{LIM_min} = 4.25$ A)

ΔI_L = Inductor peak-to-peak ripple current

The peak switch current I_{SWPEAK} is the current that the integrated switch, the inductor and the external Schottky diode have to be able to handle. The calculation must be done for the minimum input voltage where the peak switch current is the highest.

Device Functional Modes (continued)

7.4.1.7 Inductor Selection

- Inductor value:** $4.7 \mu\text{H} \leq L \leq 10 \mu\text{H}$ The higher the inductor value the lower the inductor current ripple and the output voltage ripple but the slower the transient response.
- Saturation current:** $I_{\text{SAT}} \geq I_{\text{SWPEAK}}$ or $I_{\text{SAT}} \geq I_{\text{LIM_max}}$ The inductor saturation current must be higher than the switch peak current for the max. peak output current or as a more conservative approach higher than the max. switch current limit.
- DC resistance:** The lower the inductors resistance the lower the losses and the higher the efficiency.

INDUCTANCE	SUPPLIER ⁽¹⁾	COMPONENT CODE	SIZE (L x W x H mm)	DCR Typ. (mΩ)	I _{SAT} (A)
6.8 μH	Sumida	CDRH105R	10.5 x 10.3 x 5.1	14	5.4
6.8 μH	Sumida	CDRH10D43R	10.8 x 10.5 x 4.5	20	7
10 μH	Sumida	CDRH10D43R	10.8 x 10.5 x 4.5	26	5.2
6.8 μH	Chilisin	SCDS105R	10.5 x 10.3 x 5.1	14	5.4
6.8 μH	Chilisin	SCDS104R	10.5 x 10.3 x 4	21	5
10 μH	Chilisin	SCDS105R	10.5 x 10.3 x 5.1	22	4.45

(1) See [Third-Party Products](#) disclaimer

7.4.1.8 Rectifier Diode Selection

7.4.1.8.1 Diode Type

Schottky or Super Barrier Rectifier (SBR) for better efficiency

7.4.1.8.2 Forward Voltage

The lower the forward voltage V_F the higher the efficiency and the lower the diode temperature.

7.4.1.8.3 Reverse Voltage

V_R must be higher than the output voltage and should be higher than the OVP voltage 22.5 V

7.4.1.8.4 Thermal Characteristics

The diode must be able to handle the dissipated power of:

$$P_D = V_F \times I_{\text{OUT}} \quad (2)$$

Table 1. Diodes

V_R / I_{AVG}	V_F Typ. at 25°C	COMPONENT CODE	$R_{\theta\text{JL}}$	SIZE	SUPPLIER ⁽¹⁾
30 V / 3 A	0.39 V at 3 A	SBR3U30P1	5 °C/W	PowerDI@ 123	Diodes
30 V / 3 A	0.39 V at 3 A	SSM33LSPT	18 °C/W	SMA-S	Chenmko
40 V / 3 A	0.38 V at 3 A	SSM34LAS	18 °C/W	SMA-S	Chenmko
40 V / 2 A	0.5 V at 2 A	SSM24APT	20 °C/W	SMA-S	Chenmko

(1) See [Third-Party Products](#) disclaimer

7.4.1.9 Output Capacitor Selection

For best output voltage filtering, low ESR ceramic capacitors are recommended. Four 10 μF (or two 22 μF) ceramic capacitors work for most applications. To improve the load transient response more capacitance can be added. Between the rectifier diode and the SWI-pin one 10 μF capacitor is required.

To calculate the output voltage ripple the following equations can be used:

$$\Delta V_{C_RIPPLE} = \frac{V_{AVDD} - V_{IN}}{V_{AVDD}} \times \frac{I_{OUT}}{C_{OUT}} \times f_S + \Delta V_{C_ESR} \quad \Delta V_{C_ESR} = I_{SWPEAK} \times R_{C_ESR} \quad (3)$$

CAPACITOR	VOLTAGE RATING	TEMPERATURE CHARACTERISTICS	SUPPLIER ⁽¹⁾	COMPONENT CODE
10 μ F / 1206	25 V	X5R	Murata	GRM31CR61E106KA12
10 μ F / 1206	25 V	X7R	Taiyo Yuden	TMK316AB7106KL

(1) See [Third-Party Products](#) disclaimer.

7.4.2 Buck 1 Converter ($V_{(IO)}$)

The non-synchronous current mode buck 1 converter operates with Pulse Width Modulation (PWM) with a fixed frequency of 750 kHz. The converter features integrated soft-start, bootstrap and compensation to minimize external component and pin count.

The buck 1 converter operates in Discontinuous Conduction Mode (DCM) or Continuous Conduction Mode (CCM) depending on the load current. For low load currents the converter operates in DCM. In this mode the inductor current reaches 0 A when the switch is turned off. With increasing load current the inductor current finally does not reach 0 A anymore but is always positive and then the converter operates in CCM. The switch node waveforms for DCM and CCM operation are shown in [Figure 23](#) and [Figure 24](#). The ringing during DCM (at light load) is normal for this operating mode, it occurs because of parasitic capacitance in the PCB layout. Because there is very little energy contained in the ringing waveform it does not significantly affect EMI performance.

Minimum output current for DCM:
$$I_{DCM} = \frac{V_{IN} - V_{IO}}{2 \times L \times f_S} \times \frac{V_{IO}}{V_{IN}}$$

For low load currents when the minimum on time is not sufficient, the buck 1 converter uses a skip mode to be able to regulate its output voltage $V_{(IO)}$. During the skip mode the converter switches for a few cycles to raise the output voltage then it stops switching until the output voltage falls below a given threshold and the converter starts switching again. Due to this behavior the output voltage ripple can be slightly higher during skip mode.

7.4.2.1 Soft-Start

The buck 1 converter is enabled with the undervoltage lockout (UVLO). It starts switching and ramps up its output voltage $V_{(IO)}$ linearly in 3 ms to the programmed voltage value.

7.4.2.2 Setting the Output Voltage $V_{(IO)}$

The output voltage is programmable by I²C between 2.2 V and 3.7 V in 100 mV steps.

7.4.2.3 Design Procedure

The first step in the design procedure is to verify whether the maximum possible output current of the buck 1 converter supports the specific application requirements. Because the buck 2 converter is supplied by the buck 1 converter and the negative charge pump is driven from the buck 1 converter's switch node the effective output current $I_{(IO)}$ is higher than the buck 1 output current alone.

1. Converter Duty Cycle: $D = \frac{V_{IO}}{V_{IN} \times \eta}$
2. Inductor ripple current: $\Delta I_L = \frac{(V_{IN} - V_{IO}) \times D}{f_S \times L}$
3. Maximum output current: $I_{OUT_max} = I_{LIM_min} - \frac{\Delta I_L}{2}$
4. Peak switch current: $I_{SWPEAK} = I_{OUT} + \frac{\Delta I_L}{2}$
5. Effective output current: $I_{BUCK1_EFFECTIVE} = I_{OUT_BUCK1} + I_{IN_BUCK2} + \frac{V_{IN} \times I_{GL}}{V_{IO}}$

η = Estimated boost converter efficiency (use the number from the efficiency plots or 0.8 as an estimation)
 f_s = Switching frequency (typ. 750 kHz)
 L = Selected inductor value (typ. 6.8 μ H)
 I_{LIM_min} : Minimum current limit (3 A)
 I_{SWPEAK} = Peak switch current for the used output current (must be $< I_{LIM_min} = 3$ A)
 ΔI_L = Inductor peak-to-peak ripple current

The peak switch current I_{SWPEAK} is the current that the integrated switch, the inductor and the external Schottky diode have to be able to handle. The calculation must be done for the maximum input voltage where the peak switch current is the highest.

7.4.2.4 Inductor Selection

Inductor value: $4.7 \mu\text{H} \leq L \leq 10 \mu\text{H}$ The higher the inductor value the lower the inductor current ripple and the output voltage ripple but the slower the transient response.

Saturation current: $I_{SAT} \geq I_{SWPEAK}$
or
 $I_{SAT} \geq I_{LIM_max}$ The inductor saturation current must be higher than the switch peak current for the max. peak output current or as a more conservative approach higher than the max. switch current limit.

DC resistance: The lower the inductors resistance the lower the losses and the higher the efficiency.

INDUCTANCE	SUPPLIER ⁽¹⁾	COMPONENT CODE	SIZE (L x W x H mm)	DCR Typ. (m Ω)	I_{SAT} (A)
6.8 μ H	Sumida	CDRH8D43	8.3 x 8.3 x 4.5	20	4.4
10 μ H	Sumida	CDRH8D43	8.3 x 8.3 x 4.5	29	4
6.8 μ H	Chilisin	SCPS0740T	7.5 x 7.8 x 4	28	3.9

(1) See [Third-Party Products](#) disclaimer

7.4.2.5 Rectifier Diode Selection

7.4.2.5.1 Diode Type

Schottky or Super Barrier Rectifier (SBR) for better efficiency

7.4.2.5.2 Forward Voltage

The lower the forward voltage V_F the higher the efficiency and the lower the diode temperature.

7.4.2.5.3 Reverse Voltage

V_R must be higher than the output voltage

7.4.2.5.4 Forward Current

The average rectified forward current I_{AVG} must be higher than $I_{OUT} \times (1 - D)$

7.4.2.5.5 Thermal Characteristics

The diode must be able to handle the dissipated power of:

$$P_D = V_F \times I_{OUT} \times (1 - D) \quad (4)$$

Table 2. Diodes

V_R / I_{AVG}	V_F typ. at 25°C	COMPONENT CODE	$R_{\theta JL}$	SIZE	SUPPLIER ⁽¹⁾
30 V / 3 A	0.39 V at 3 A	SBR3U30P1	5 °C/W	PowerDI@ 123	Diodes
30 V / 3 A	0.39 V at 3 A	SSM33LSPT	18 °C/W	SMA-S	Chenmko
40 V / 3 A	0.38 V at 3 A	SSM34LAS	18 °C/W	SMA-S	Chenmko
40 V / 2 A	0.5 V at 2 A	SSM24APT	20 °C/W	SMA-S	Chenmko

(1) See [Third-Party Products](#) disclaimer

7.4.2.6 Output Capacitor Selection

For best output voltage filtering low ESR ceramic capacitors are recommended. Three 10 μF (or two 22 μF) ceramic capacitors work for most applications. To improve the load transient response more capacitance can be added.

To calculate the output voltage ripple the following equations can be used:

$$\Delta V_{C_RIPPLE} = \frac{V_{IO}}{V_{IN} \times f_S} \times \frac{I_{OUT}}{C_{OUT}} + \Delta V_{C_ESR} \quad \Delta V_{C_ESR} = I_{SWPEAK} \times R_{C_ESR} \quad (5)$$

CAPACITOR	VOLTAGE RATING	TEMPERATURE CHARACTERISTICS	SUPPLIER ⁽¹⁾	COMPONENT CODE
10 μF / 1206	6.3 V	X5R	Murata	GRM219R60J106KE19
10 μF / 1206	6.3 V	X7R	Taiyo Yuden	JMK212AB7106KG

(1) See [Third-Party Products](#) disclaimer

7.4.3 BUCK 2 CONVERTER (V_{CORE})

The synchronous current mode buck 2 converter operates with Pulse Frequency Modulation (PFM) with a fixed off-time and a typ. frequency of 1 MHz. The converter features integrated soft-start, bootstrap and compensation to minimize external component and pin count. It is supplied by the buck 1 converter's output.

If not needed the buck 2 converter can be disabled by I²C.

7.4.3.1 Soft-Start

The buck 2 converter is enabled when the buck 1 converter is in regulation. It starts switching and ramps up its output voltage V_{CORE} linearly in 3ms to the programmed voltage value.

7.4.3.2 Setting the Output Voltage V_{CORE}

The output voltage is programmable by I²C between 0.8 V and 3.3 V in 100 mV steps.

7.4.3.3 Design Procedure

The first step in the design procedure is to verify whether the maximum possible output current of the buck 2 converter supports the specific application requirements.

- Switching frequency: $f_S = \frac{(V_{IO} - V_{CORE}) \times (1.17V_{CORE} + 0.22)}{V_{IO}}$ MHz
- Converter Duty Cycle: $D = \frac{V_{CORE}}{V_{IO} \times \eta}$
- Inductor ripple current: $\Delta I_L = \frac{(V_{IO} - V_{CORE}) \times D}{f_S \times L}$
- Maximum output current: $I_{OUT_max} = I_{LIM_min} - \frac{\Delta I_L}{2}$
- Peak switch current: $I_{SWPEAK} = I_{OUT} + \frac{\Delta I_L}{2}$

η = Estimated boost converter efficiency (use the number from the efficiency plots or 0.8 as an estimation)

L = Selected inductor value (typ. 6.8 μH)

I_{LIM_min} : Minimum current limit (2.5A)

I_{SWPEAK} = Peak switch current for the used output current (must be $< I_{LIM_min} = 2.5$ A)

ΔI_L = Inductor peak-to-peak ripple current

The peak switch current I_{SWPEAK} is the current that the switch and the inductor have to be able to handle.

7.4.3.4 Inductor Selection

Inductor value: $4.7\mu\text{H} \leq L \leq 10\mu\text{H}$ The higher the inductor value the lower the inductor current ripple and the output voltage ripple but the slower the transient response.

Saturation current: $I_{\text{SAT}} \geq I_{\text{SWPEAK}}$
 or
 $I_{\text{SAT}} \geq I_{\text{LIM_max}}$ The inductor saturation current must be higher than the switch peak current for the max. peak output current or as a more conservative approach higher than the max. switch current limit.

DC resistance: The lower the inductors resistance the lower the losses and the higher the efficiency.

INDUCTANCE	SUPPLIER ⁽¹⁾	COMPONENT CODE	SIZE (L x W x H mm)	DCR typ. (mΩ)	I _{SAT} (A)
4.7 μH	Sumida	CDRH5D28R/HP	6.2 x 6.2 x 3	35	3.7
6.8 μH	Sumida	CDRH5D28R/HP	6.2 x 6.2 x 3	49	3.1
4.7 μH	Chilisin	SCPS0725T	7.8 x 7.7 x 2.5	40	4
6.8 μH	Chilisin	SCPS0725T	7.8 x 7.7 x 2.5	66	3.5
4.7 μH	Chilisin	LVS606028	6.2 x 6.2 x 2.2	38	3.7
6.8 μH	Chilisin	LVS606028	6.2 x 6.2 x 2.2	50	3.1
4.7 μH	Mag Layers	MSCDRI-7025AL	8 x 8 x 2.5	45	3.5
6.8 μH	Mag Layers	MSCDRI-7025AL	8 x 8 x 2.5	63	3.1

(1) See [Third-Party Products](#) disclaimer

7.4.3.5 Output Capacitor Selection

For best output voltage filtering low ESR ceramic capacitors are recommended. Three 10 μF (or one 22 μF) ceramic capacitors work for most applications. To improve the load transient response more capacitance can be added.

To calculate the output voltage ripple the following equations can be used:

$$\Delta V_{\text{C_RIPPLE}} = \frac{V_{\text{CORE}}}{V_{\text{IO}} \times f_{\text{S}}} \times \frac{I_{\text{OUT}}}{C_{\text{OUT}}} + \Delta V_{\text{C_ESR}} \quad \Delta V_{\text{C_ESR}} = I_{\text{SWPEAK}} \times R_{\text{C_ESR}} \quad (6)$$

CAPACITOR	VOLTAGE RATING	TEMPERATURE CHARACTERISTICS	SUPPLIER ⁽¹⁾	COMPONENT CODE
10 μF / 1206	6.3 V	X5R	Murata	GRM219R60J106KE19
10 μF / 1206	6.3 V	X7R	Taiyo Yuden	JMK212AB7106KG

(1) See [Third-Party Products](#) disclaimer

7.4.4 Buck 3 Converter (V_(HAVDD))

The synchronous current mode buck 3 converter operates with Pulse Frequency Modulation (PFM) with a fixed off-time and a typ. frequency of 1 MHz. The converter features integrated soft-start, bootstrap and compensation to minimize external component and pin count.

If not needed the buck 3 converter can be disabled by I²C.

7.4.4.1 Soft-Start

The buck 3 converter is enabled together with the boost converter. It starts switching and ramps up its output voltage V_(HAVDD) to the programmed voltage value tracking the boost converters output voltage V_(AVDD).

7.4.4.2 Setting the Output Voltage V_(HAVDD)

The output voltage is programmable by I²C between 4.8 V and 11.1 V in 100 mV steps.

7.4.4.3 High Voltage Stress Mode (HVS)

By pulling the HVS-pin “high” an I²C programmable offset voltage is added to the set boost and buck 3 converters output voltage V_(AVDD) and V_(HAVDD). The offset voltages are programmable independently.

7.4.4.4 Design Procedure

The first step in the design procedure is to verify whether the maximum possible output current of the buck 3 converter supports the specific application requirements.

1. Switching frequency: $f_S = \frac{0.76 \times V_{HAVDD} \times V_{IN} - V_{HAVDD}}{V_{IN}} \text{ MHz}$
2. Converter Duty Cycle: $D = \frac{V_{HAVDD}}{V_{IN} \times \eta}$
3. Inductor ripple current: $\Delta I_L = \frac{(V_{IN} - V_{HAVDD}) \times D}{f_S \times L}$
4. Maximum output current: $I_{OUT_max} = I_{LIM_min} - \frac{\Delta I_L}{2}$
5. Peak switch current: $I_{SWPEAK} = I_{OUT} + \frac{\Delta I_L}{2}$

η = Estimated boost converter efficiency (use the number from the efficiency plots or 0.8 as an estimation)

f_S : Switching frequency (typ. 1 MHz)

L = Selected inductor value (typ. 6.8 μH)

I_{LIM_min} : Minimum current limit (1.7 A)

I_{SWPEAK} = Peak switch current for the used output current (must be < I_{LIM_min} = 1.7 A)

ΔI_L = Inductor peak-to-peak ripple current

The peak switch current I_{SWPEAK} is the current that the switch and the inductor have to be able to handle.

7.4.4.5 Inductor Selection

Inductor value: $4.7 \mu\text{H} \leq L \leq 10 \mu\text{H}$ The higher the inductor value the lower the inductor current ripple and the output voltage ripple but the slower the transient response.

Saturation current: $I_{SAT} \geq I_{SWPEAK}$
or
 $I_{SAT} \geq I_{LIM_max}$ The inductor saturation current must be higher than the switch peak current for the max. peak output current or as a more conservative approach higher than the max. switch current limit.

DC resistance: The lower the inductors resistance the lower the losses and the higher the efficiency.

INDUCTANCE	SUPPLIER ⁽¹⁾	COMPONENT CODE	SIZE (L x W x H mm)	DCR typ. (m Ω)	I_{SAT} (A)
4.7 μH	Chilisin	SCDS6D28T	7 x 7 x 3	25	2.5
6.8 μH	Chilisin	SCDS6D28T	7 x 7 x 3	40	2.1
4.7 μH	Chilisin	SCPS0725T	7.8 x 7.7 x 2.5	40	4
6.8 μH	Chilisin	SCPS0725T	7.8 x 7.7 x 2.5	66	3.5
4.7 μH	Chilisin	LVS404018	4.2 x 4.2 x 2	90	2
6.8 μH	Chilisin	LVS404018	4.2 x 4.2 x 2	110	1.6
4.7 μH	Mag Layers	MSCDRI-7025AL	8 x 8 x 2.5	45	3.5
6.8 μH	Mag Layers	MSCDRI-7025AL	8 x 8 x 2.5	63	3.1

(1) See [Third-Party Products](#) disclaimer

7.4.4.6 Output Capacitor Selection

For best output voltage filtering low ESR ceramic capacitors are recommended. One 10 μF ceramic capacitor works for most applications. To improve the load transient response more capacitance can be added.

To calculate the output voltage ripple the following equations can be used:

$$\Delta V_{C_RIPPLE} = \frac{V_{HAVDD}}{V_{IN} \times f_S} \times \frac{I_{OUT}}{C_{OUT}} + \Delta V_{C_ESR} \quad \Delta V_{C_ESR} = I_{SW_PEAK} \times R_{C_ESR} \quad (7)$$

CAPACITOR	VOLTAGE RATING	TEMPERATURE CHARACTERISTICS	SUPPLIER ⁽¹⁾	COMPONENT CODE
10 μ F / 1206	16 V	X5R	Murata	GRM31CR61C106KA88
10 μ F / 1206	16 V	X7R	Taiyo Yuden	EMK316AB7106KL

(1) See [Third-Party Products](#) disclaimer

7.4.5 Positive Charge Pump Controller ($V_{(GH)}$) with Temperature Compensation

The positive charge pump is driven from the boost converter's switch node and regulated by controlling the current through an external PNP transistor. The controller is optimized for transistors with a DC gain (h_{FE}) between 100 and 300, a base drive current up to 5 mA is supported. A temperature compensation for its output voltage $V_{(GH)}$ is implemented and the levels of the output voltages are programmed by I²C.

The positive charge pump and the temperature compensation function can be disabled by I²C separately.

7.4.5.1 Soft-Start

The positive charge pump controller is enabled when the boost converter is in regulation. The output voltage $V_{(GH)}$ ramps up to the programmed voltage in typ. 1.5 ms.

7.4.5.2 Setting the Output Voltage $V_{(GH)}$

The low voltage $V_{(GH_LOW)}$ at high temperature is programmed directly by I²C from 20 V to 35 V in 1 V steps, the high voltage $V_{(GH_HIGH)}$ at low temperature is programmed with a positive offset voltage of 1 V steps relative to $V_{(GH_LOW)}$. An external NTC thermistor with a resistor network (R_P and R_L) sets the temperatures when $V_{(GH_LOW)}$ ($V_{NTC} \leq 1$ V, hot) and $V_{(GH_HIGH)}$ ($V_{NTC} \geq 2$ V, cold) are reached. To achieve a linear curve between $V_{(GH_LOW)}$ and $V_{(GH_HIGH)}$ a suitable linearization resistor parallel to the NTC must be used.

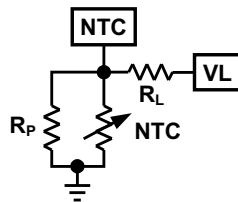

R_{T_0} is the resistance at an absolute temperature T_0 in Kelvin (normally 25°C)

T is the temperature in Kelvin ($^{\circ}\text{C} + 273.15$ K/ $^{\circ}\text{C}$)

B is a material constant provided by the NTC supplier

$$R_{NTC}(T) = R_{T_0} \times e^{-B \times \left(\frac{1}{T_0} - \frac{1}{T} \right)}$$

V_L : Internal supply voltage $V_L = 5$ V

$R_{NTC}(T_{HOT})$: NTC resistance hot

$R_{NTC}(T_{COLD})$: NTC resistance cold

$$R_P = \frac{V_L \times R_{NTC}(T_{HOT}) \times R_{NTC}(T_{COLD})}{V_L \times R_{NTC}(T_{COLD}) - 2V_L \times R_{NTC}(T_{HOT}) + 2R_{NTC}(T_{HOT}) - 2R_{NTC}(T_{COLD})}$$

$$R_L = \frac{R_P \times R_{NTC}(T_{HOT}) \times (V_L - 1V)}{R_P + R_{NTC}(T_{HOT})}$$

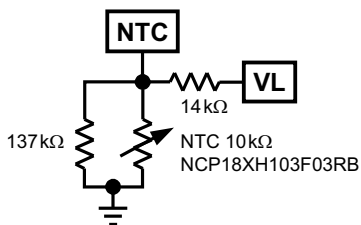
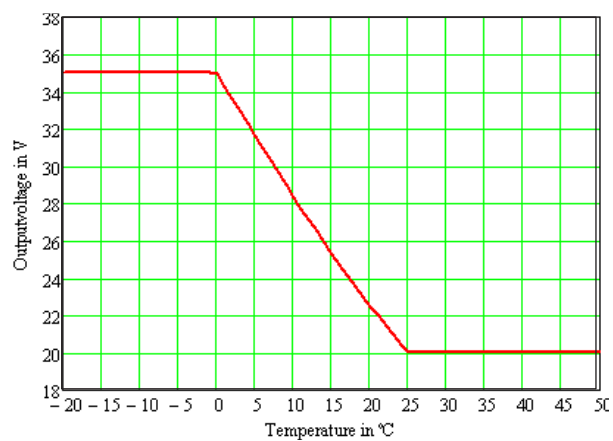
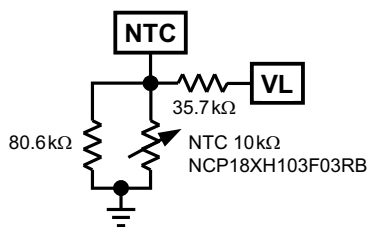
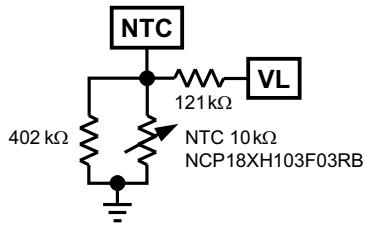

7.4.5.3 Design Procedure

1. Supported max. output voltage

The maximum possible output voltage is calculated as follows:

$$\text{Doubler Mode: } V_{GH_max} = V_{INPUT} + V_{AVDD} - 2V_F - V_Q - R \times I_{GH} \times \left(\frac{1}{D} + \frac{1}{1-D} \right) - \frac{I_{GH}}{C \times f_S}$$

$$\text{Tripler Mode: } V_{GH_max} = V_{INPUT} + 2V_{AVDD} - 4V_F - V_Q - 2R \times I_{GH} \times \left(\frac{1}{D} + \frac{1}{1-D} \right) - \frac{2I_{GH}}{C \times f_S}$$

V_F : Diode forward voltage
 R : Switch node resistor
 V_{INPUT} : Transistor emitter voltage
 D : Boost duty cycle
 C : Flying capacitor value
 f_S : Boost switching frequency (750kHz)
 V_Q : Collector-emitter saturation voltage

2. Diode selection

Diode type: No specific type required

Forward voltage: The lower the forward voltage V_F the higher the maximum output voltage

Reverse voltage: V_R must be higher than the switching voltage applied at the flying capacitor

Forward current: The average forward current I_{AVG} must be higher than the output current I_{OUT}

Thermal characteristics: The diode must be able to handle the dissipated power of $P_D = V_F \times I_{OUT}$

Peak currents of up to some amps through the diodes can occur during start-up for a few cycles. This condition lasts for <1ms and can be tolerated by many diodes whose repetitive peak current rating is much lower.

V_R / I_{AVG}	V_F typ. at 25°C	COMPONENT CODE	$R_{\theta JA}$	SIZE	SUPPLIER ⁽¹⁾
85 V / 150 mA	1.1 V at 150 mA	BAV99TPT		SOT-416	Chenmko
75 V / 300 mA	1 V at 150 mA	BAV99W	625 °C/W	SOT-323	Diodes
75 V / 215 mA	1.1 V at 150 mA	BAV99BDWPT	625 °C/W	SOT-363	Chenmko
75 V / 300 mA	1 V at 150 mA	BAV99BRW	625 °C/W	SOT-363	Diodes
75 V / 300 mA	1 V at 150 mA	BAV99T	833 °C/W	SOT-523	Diodes
30 V / 1 A	0.47 V at 1 A	CH511H-30PT	625 °C/W	SOT-323	Chenmko
40 V / 200 mA	0.9 V at 200 mA	BAS40W-04	625 °C/W	SOT-323	Diodes
40 V / 200 mA	0.9 V at 200 mA	BAS40-04T	833 °C/W	SOT-523	Diodes
30 V / 200 mA	0.65 V at 200 mA	BAT54SW	625 °C/W	SOT-323	Diodes
30 V / 200 mA	0.65 V at 200 mA	BAT54ST	833 °C/W	SOT-523	Diodes
75 V / 300 mA	1 V at 200 mA	MMBD7000	357 °C/W	SOT-23	Diodes

(1) See [Third-Party Products](#) disclaimer

3. Transistor selection

DC gain (h_{FE}): At least 35 when the transistors collector current is equal to the output current, for good performance 75 to 200 is recommended

Collector-Emitter voltage: V_{CEO} must be at least the input voltage (Emitter voltage) + switching voltage V_{AVDD}

DC Collector current: Must be higher than the output current $I_{OUT} / (1 - \text{boost duty cycle})$

Thermal characteristics: The transistor must be able to handle the dissipated power of:

$$P_{DIS} = (V_{INPUT} + V_{AVDD} - 2V_F - V_{GH}) \times I_{GH} - R \times I_{GH}^2 \times \left(\frac{1}{D^2} + \frac{1}{(1-D)^2} \right) - \frac{I_{GH}}{C \times f_S}$$

Doubler Mode:

$$P_{DIS} = (V_{INPUT} + 2V_{AVDD} - 4V_F - V_{GH}) \times I_{GH} - 2R \times I_{GH}^2 \times \left(\frac{1}{D^2} + \frac{1}{(1-D)^2} \right) - \frac{2I_{GH}}{C \times f_S}$$

Tripler Mode:

V_{INPUT} : Input voltage
 V_F : Diode forward voltage
 I_{GH} : Mean output current
 D : Boost duty cycle
 R : Switch node resistor
 C : Flying capacitor value

f_S : Boost switching frequency (750kHz)

The total power dissipation of the chosen package is specified with a very good thermal designed PCB. The specified max. power dissipation can only be dissipated if the cooling area at the PCB is big enough. The total area should be at least 5 cm² it can be spread over different layers when using many vias.

V _{CEO} / I _C	h _{FE} min...max.	V _{CEsat}	COMPONENT CODE	P _{tot}	SIZE	SUPPLIER ⁽¹⁾
-60 V / -600 mA	100...300 at -150 mA	-150 mV	CHT2907XPT	1.2 W	SOT-89	Chenmko
-40 V / -200 mA	60...300 at -50 mA	-200 mV	CH3906XPT	1.2 W	SOT-89	Chenmko
-50 V / -2 A	70...240 at -500 mA	-150 mV	KTA1666	1 W	SOT-89	KEC
-60 V / -1 A	50...200 at -500 mA	-300 mV	KTA1668	1 W	SOT-89	KEC
-60 V / -600 mA	100...300 at -150 mA	-150 mV	PZT2907AT1	1.5 W	SOT-223	ON Semi

(1) See [Third-Party Products](#) disclaimer

4. Base-Emitter resistor selection

A 100-kΩ base-emitter resistor is required to ensure proper operation. It is needed to ensure that the transistor can be turned off completely. Too low resistor value reduce the maximum base drive current.

5. Flying capacitor selection

A flying capacitor of 470 nF is appropriate for most applications. Larger capacitances have a smaller voltage drop ΔV at the end of each switching cycle and support therefore higher output voltages and currents. The voltage rating must be at least the switching voltage V_(AVDD).

C: Flying capacitor value

f_S : Boost switching frequency (750kHz) $\Delta V = \frac{I_{GH}}{C \times f_S}$

CAPACITOR	VOLTAGE RATING	TEMPERATURE CHARACTERISTICS	SUPPLIER ⁽¹⁾	COMPONENT CODE
470 nF / 0603	25 V	X7R	Murata	GRM188R71E474KA12
470 nF / 0603	25 V	X5R	Taiyo Yuden	TMK107BJ474KA

(1) See [Third-Party Products](#) disclaimer

6. Switch node resistor selection

For less boost converter disturbance and therefore lower boost output voltage ripple $\Delta V_{(AVDD)}$ and lower diode current spikes a resistor should be added in the switching path. The higher the resistance the lower the disturbances and the peak currents but also the lower the maximum output current and the higher the resistors power dissipation P_R. A 1 Ω to 2.2 Ω resistor is appropriate for most applications.

I_{GH}: V_{GH} mean output current

D: Boost converter duty cycle

R: Switch node resistor

$$P_R = R \times I_{GH}^2 \times \left(\frac{1}{D} + \frac{1}{1-D} \right)$$

7.4.5.4 Output Capacitor Selection

For best output voltage filtering low ESR ceramic capacitors are recommended. One 4.7 μF ceramic capacitor works for most applications. To improve the load transient response more capacitance can be added.

CAPACITOR	VOLTAGE RATING	TEMPERATURE CHARACTERISTICS	SUPPLIER ⁽¹⁾	COMPONENT CODE
4.7 μF / 1206	50 V	X7R	Murata	GRM31CR71H475KA12
4.7 μF / 1206	50 V	X5R	Taiyo Yuden	UMK316BJ475KL

(1) See [Third-Party Products](#) disclaimer

7.4.6 Negative Charge Pump Controller (V_(GL))

The negative charge pump usually is driven from the buck 1 converter's switch node but can also be connected to the boost converter's switch node and regulated by controlling the current through an external NPN transistor. The controller is optimized for transistors with a DC gain (h_{FE}) between 100 and 300, a base drive current up to 5 mA is supported.

The negative charge pump can be disabled by I²C.

TPS65177A:

When V_(GL) is driven by the boost switch pin (SW) the EN-pin should be connected to V_I, otherwise V_(GL) detects a short when EN is pulled low as the V_(GL) voltage collapses. V_(GL) collapses because the supporting switch node (SW) stops switching and the device partially shuts down as described in the [Short-Circuit and Overload Protection](#) section. The device is in a latched state and only a power cycle can restart the V_(AVDD), V_(HAVDD), V_(GH) and V_(GL) rail.

7.4.6.1 Soft-Start

The negative charge pump controller is enabled when the buck 2 converter is in regulation. The output voltage V_(GL) ramps up to the programmed voltage in typ. 1.5 ms.

7.4.6.2 Setting the Output Voltage V_(GL)

The output voltage is programmable by I²C between –14.5 V and –5.5 V in 600 mV steps.

7.4.6.3 Design Procedure

1. Supported max. output voltage

The maximum possible negative output voltage is calculated as follows:

Using buck 1 converter's switch node:

$$\text{Inverter: } V_{GL_max} = V_{INPUT} - V_{IN} + 2V_F + V_Q + R \times I_{GL} \times \left(\frac{1}{D} + \frac{1}{1-D} \right) + \frac{I_{GL}}{C \times f_S}$$

V_{INPUT}: Transistor emitter node voltage

V_F: Diode forward voltage

R: Switch node resistor

D: Buck duty cycle

C: Flying capacitor value

f_S: Boost and Buck1 switching frequency (750kHz)

V_Q: Collector-emitter saturation voltage

Using boost converter's switch node:

$$\text{Inverter: } V_{GL_max} = V_{INPUT} - V_{AVDD} + 2V_F + V_Q + \frac{R \times I_{GL}^2}{D \times (1-D)} + \frac{I_{GL}}{C \times f_S}$$

2. Diode selection

Diode type: No specific type required

Forward voltage: The lower the forward voltage V_F the higher the maximum output voltage

Reverse voltage: V_R must be higher than the switching voltage applied at the flying capacitor V_{IN} or V_{AVDD}

Forward current: The average forward current I_{AVG} must be higher than the output current I_{OUT}

Thermal characteristics: The diode must be able to handle the dissipated power of P_D = V_F × I_{OUT}

Peak currents of up to some amps through the diodes can occur during start-up for a few cycles. This condition lasts for < 1 ms and can be tolerated by many diodes whose repetitive peak current rating is much lower.

V _R / I _{AVG}	V _F typ. at 25°C	COMPONENT CODE	R _{θJA}	SIZE	SUPPLIER ⁽¹⁾
85 V / 150 mA	1.1 V at 150 mA	BAV99TPT		SOT-416	Chenmko
75 V / 300 mA	1 V at 150 mA	BAV99W	625 °C/W	SOT-323	Diodes
75 V / 215 mA	1.1 V at 150 mA	BAV99BDWPT	625 °C/W	SOT-363	Chenmko
75 V / 300 mA	1 V at 150 mA	BAV99BRW	625 °C/W	SOT-363	Diodes
75 V / 300 mA	1 V at 150 mA	BAV99T	833 °C/W	SOT-523	Diodes

(1) See [Third-Party Products](#) disclaimer

V_R / I_{AVG}	V_F typ. at 25°C	COMPONENT CODE	$R_{\theta JA}$	SIZE	SUPPLIER ⁽¹⁾
30 V / 1 A	0.47 V at 1 A	CH511H-30PT	625 °C/W	SOT-323	Chenmko
40 V / 200 mA	0.9 V at 200 mA	BAS40W-04	625 °C/W	SOT-323	Diodes
40 V / 200 mA	0.9 V at 200 mA	BAS40-04T	833 °C/W	SOT-523	Diodes
30 V / 200 mA	0.65 V at 200 mA	BAT54SW	625 °C/W	SOT-323	Diodes
30 V / 200 mA	0.65 V at 200 mA	BAT54ST	833 °C/W	SOT-523	Diodes
75 V / 300 mA	1 V at 200 mA	MMBD7000	357 °C/W	SOT-23	Diodes

3. Transistor selection

DC gain (h_{FE}): At least 35 when the transistors collector current is equal to the output current, for good performance 75 to 200 is recommended

Collector-Emitter voltage: V_{CEO} must be at least the input voltage (Emitter voltage) + switching voltage V_I or $V_{(AVDD)}$

DC Collector current: Must be higher than the output current $I_{OUT} / (1 - \text{buck duty cycle})$ or $I_{OUT} / \text{boost duty cycle}$

Thermal characteristics: The transistor must be able to handle the dissipated power of:

Using buck 1 converter's switch node:

$$\text{Inverter: } P_{DIS} = (V_{IN} - V_{INPUT} - 2V_F - |V_{GL}|) \times I_{GL} - R \times I_{GL}^2 \times \left(\frac{1}{D^2} + \frac{1}{(1-D)^2} \right) - \frac{I_{GL}}{C \times f_S}$$

V_F : Diode forward voltage

V_{INPUT} : Input voltage

I_{GL} : Mean output current

R: Switch node resistor

D: Buck duty cycle

C: Flying capacitor value

f_S : Boost and Buck 1 switching frequency (750kHz)

Using boost converter's switch node:

$$\text{Inverter: } P_{DIS} = (V_{AVDD} - V_{INPUT} - 2V_F - |V_{GL}|) \times I_{GL} - R \times I_{GL}^2 \times \left(\frac{1}{D^2} + \frac{1}{(1-D)^2} \right) - \frac{I_{GL}}{C \times f_S}$$

The total power dissipation of the chosen package is specified with a very good thermal designed PCB. The specified max. power dissipation can only be dissipated if the cooling area at the PCB is big enough. The total area should be at least 5 cm² it can be spread over different layers when using many vias.

V_{CEO} / I_C	h_{FE} min...max.	V_{CEsat}	COMPONENT CODE	P_{tot}	SIZE	SUPPLIER ⁽¹⁾
40 V / 600 mA	100...300 at 150 mA	150 mV	CHT2222XPT	1.2 W	SOT-89	Chenmko
40 V / 200 mA	60...300 at 50 mA	100 mV	CH3904XPT	1.2 W	SOT-89	Chenmko
80 V / 400 mA	50...240 at 200 mA	100 mV	KTC4374	1 W	SOT-89	KEC
30 V / 1.5 A	100...320 at 500 mA	150 mV	KTC4375	1 W	SOT-89	KEC
30 V / 800 mA	50...320 at 500 mA	150 mV	KTC4376	1 W	SOT-89	KEC
40 V / 600 mA	40...300 at 500 mA	500 mV	PZT2222AT1	1.5 W	SOT-223	ON Semi
40 V / 200 mA	60...300 at 50 mA	200 mV	PZT3904T1G	1.5 W	SOT-223	ON Semi

(1) See [Third-Party Products](#) disclaimer

4. Base-Emitter resistor selection

A 100 kΩ base-emitter (DRVN-pin to GND) resistor is integrated to ensure proper operation there is no external resistor needed. It is needed to ensure that the transistor can be turned off completely.

5. Flying capacitor selection

A flying capacitor of 470 nF is appropriate for most applications. Larger capacitances have a smaller voltage drop ΔV at the end of each switching cycle and support therefore higher output voltages and currents. The voltage rating must be at least the switching voltage V_I (using buck 1 switch) or $V_{(AVDD)}$ (using boost switch).

C: Flying capacitor value

$$f_s: \text{Buck 1 or Boost switching frequency (750 kHz)} \quad \Delta V = \frac{I_{GL}}{C \times f_s}$$

CAPACITOR	VOLTAGE RATING	TEMPERATURE CHARACTERISTICS	SUPPLIER ⁽¹⁾	COMPONENT CODE
470 nF / 0603	25 V	X7R	Murata	GRM188R71E474KA12
470 nF / 0603	25 V	X5R	Taiyo Yuden	TMK107BJ474KA

(1) See [Third-Party Products](#) disclaimer

6. Switch node resistor selection

For less buck 1 or boost converter disturbance and therefore lower buck 1 or boost output voltage ripple $\Delta V_{(IO)}$ or $\Delta V_{(AVDD)}$ and lower diode current spikes a resistor should be added in the switching path. The higher the resistance the lower the disturbances and the peak currents but also the lower the maximum output current and the higher the resistors power dissipation. A 1 Ω to 2.2 Ω resistor is appropriate for most applications

I_{GL} : V_{GL} mean output current

D: Boost converter duty cycle

R: Switch node resistor

$$P_R = R \times I_{GL}^2 \times \left(\frac{1}{D} + \frac{1}{1-D} \right)$$

7.4.6.4 Output Capacitor Selection

For best output voltage filtering low ESR ceramic capacitors are recommended. One 4.7 μ F ceramic capacitor works for most applications. To improve the load transient response more capacitance can be added.

CAPACITOR	VOLTAGE RATING	TEMPERATURE CHARACTERISTICS	SUPPLIER ⁽¹⁾	COMPONENT CODE
4.7 μ F / 1206	16 V	X5R	Murata	GRM21BR61C475KA88
4.7 μ F / 1206	16 V	X7R	Taiyo Yuden	EMK212B7475KG

(1) See [Third-Party Products](#) disclaimer

7.5 Gate Pulse Modulation ($V_{(GHM)}$)

The Gate Pulse Modulation is controlled by the CTRL-pin, except during start-up and shut-down. During start-up $V_{(GHM)}$ is kept at low state ($V_{(GHM)} = V_{(RE)}$) until Power Good of the positive charge pump $V_{(GH)}$ is reached, at shut-down $V_{(GHM)}$ follows $V_{(GH)}$ ($V_{(GHM)} = V_{(GH)}$).

If not needed the Gate Pulse Modulation can be disabled by I²C.

CTRL = 'high' $\rightarrow V_{(GHM)} = V_{(GH)}$

CTRL = 'low' $\rightarrow V_{(GHM)} = V_{(RE)}$ (discharges through RE resistor)

The slope at which $V_{(GHM)}$ discharges is set by the external resistor connected to the RE-pin, the internal MOSFET $R_{DS(ON)}$ (typ. 3 Ω) and the gate line capacitance connected to the VGHM-pin. The RE resistor must be connected to GND and it must also be able to handle the power dissipation.

A Gate Pulse Modulation limit voltage can be set by I²C programming. When the limit voltage is reached the discharging of VGHM through RE is stopped and the VGHM output is high impedance until CTRL goes "high" again, see [Figure 13](#).

Gate Pulse Modulation (V_{GHM}) (continued)

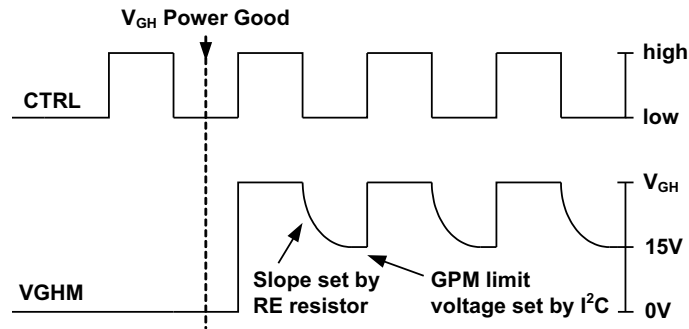

Figure 13. Gate Pulse Modulation

7.6 Programming

7.6.1 I²C Serial Interface Description

The TPS65177/A communicates through an industry standard 2-wire I²C interface to receive data in slave mode. The I²C serial interface was developed by Philips Semiconductor (see I²C-Bus Specification, Version 2.1, January 2000). The bus consists of a data line (SDA) and a clock line (SCL) with pull-up structures. When the bus is idle both SDA and SCL lines are pulled high. All the I²C compatible devices connect to the I²C bus through open drain I/O pins, SDA and SCL. A master device, usually a microcontroller or a digital signal processor, controls the bus. The master is among other things responsible for generating the SCL signal and the slave device address to communicate with a certain device. A slave device receives and/or transmits data on the bus under control of the master device. A START condition send by the master initiates a new data transfer to the slave devices. Transitioning SDA from high to low while SCL remains high generates a START condition. A STOP condition ends a data transfer to the selected slave device. Transitioning SDA from low to high while SCL remains high generates a STOP condition (see Figure 14).

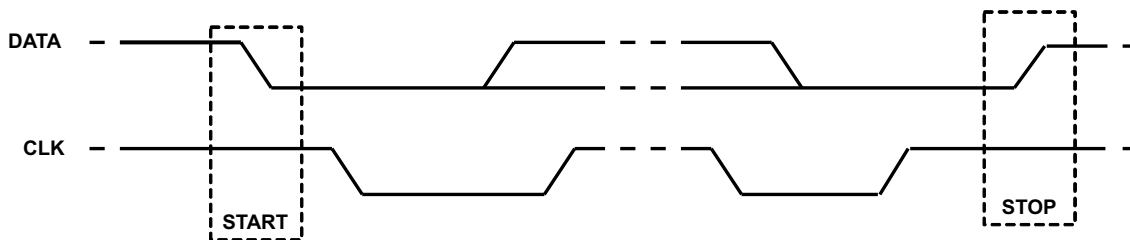

Figure 14. START and STOP Conditions

The TPS65177/A works as a slave and supports the standard mode (100 kbps) and fast mode (400 kbps) data transfer mode, as defined in the I²C-Bus specification. The data transfer protocol for standard and fast mode is exactly the same. The TPS65177/A supports 7-bit addressing. The device 7-bit address is defined as '010000X' (see Figure 15) where the bit X can be selected depending on the address pin configuration of A0 ("high" = 1, "low" = 0). The LSB enables the write or read function ("high" = read, "low" = write).

(MSB)							TPS65177 Address	(LSB)
0	1	0	0	0	0	A0	R/W	

Figure 15. TPS65177/A Slave Address Byte

The master generates the SCL pulses, transmits the 7-bit address and the read/write direction bit R/W on the SDA line. During all transmissions, the master ensures that the data is valid. A valid data condition requires the SDA line to be stable during the entire high period of the clock pulse (see Figure 16). All devices recognize the address sent by the master and compare it to their internal fixed addresses. Only the slave device with a matching address generates an Acknowledge, ACK, (see Figure 17) by pulling the SDA line low during the entire high period of the SCL cycle. Upon detecting this Acknowledge, the master knows that communication link with a slave has been established.

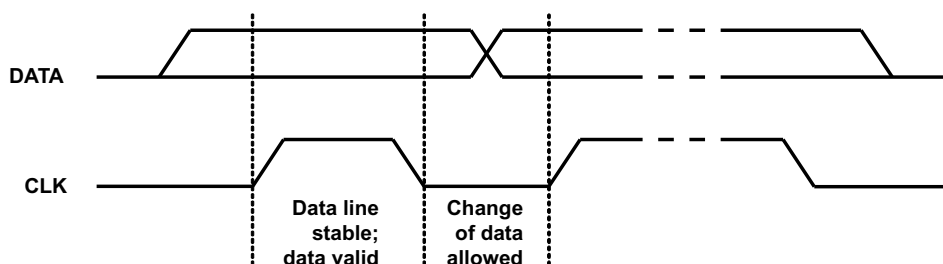

Figure 16. Bit Transfer on the Serial Interface

Programming (continued)

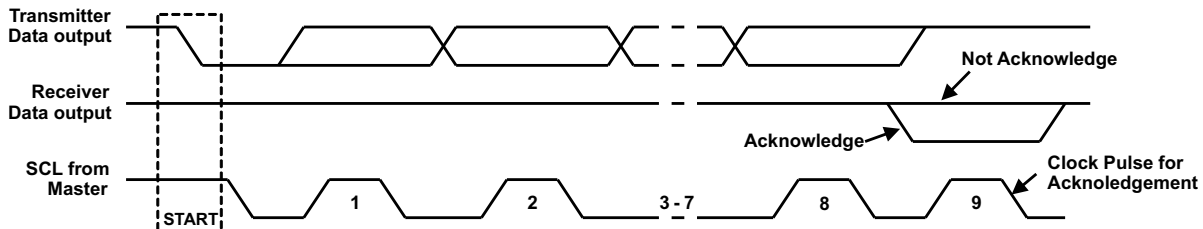

Figure 17. Acknowledge on the I²C Bus

The master generates further SCL cycles to either transmit data to the slave (R/W bit = 0) or receive data from the slave (R/W bit = 1). In either case, the receiver needs to acknowledge the data sent by the transmitter. So an acknowledge signal can either be generated by the master or by the slave, depending on which one is the receiver. The 9-bit valid data sequences consisting of 8-bit data and 1-bit acknowledge can continue as long as necessary. To terminate the data transfer, the master generates the STOP condition by pulling the SDA line from low to high while the SCL line is high (see Figure 18). This releases the bus and stops the communication link with the addressed slave. All I²C compatible devices must recognize the stop condition. Upon the receipt of a stop condition, all devices know that the bus is released and they wait for a START condition followed by a matching slave address.

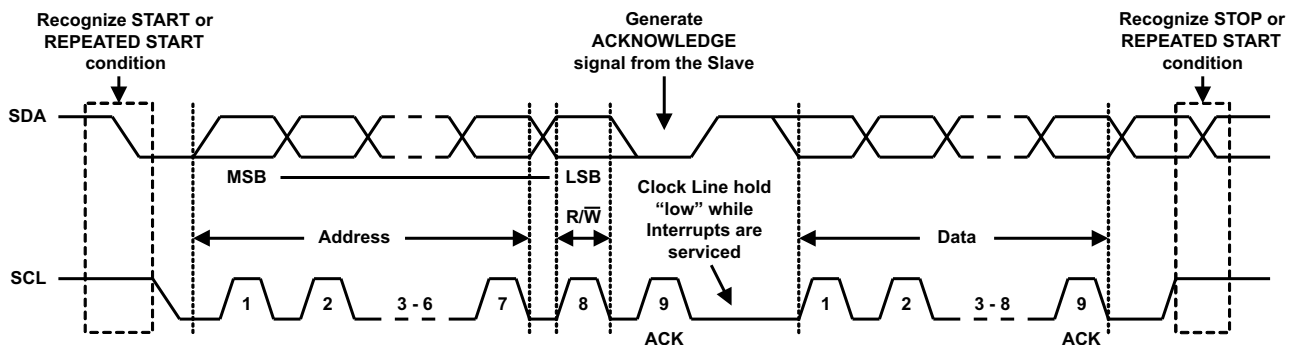

Figure 18. I²C Bus Protocol

Attempting to read data from register addresses not listed in the following section will result in 00h being read out.

7.6.2 Memory Description

A non-volatile EEPROM containing the initial values of the DACs and a volatile memory containing the DACs settings is implemented in the TPS65177/A. The non-volatile memory is called the Initial Value Register (IVR) and the volatile memory is called DAC Register (DR). The non-volatile IVR and the volatile DR are accessed by the same address. A Control Register (CR) is implemented to select if the IVR or the DR is addressed.

7.6.3 Read / Write Description

To read the volatile memory (DR) data the LSB ($\overline{EE/DR}$) of the Control Register (CR) must be set to 0, to read the non-volatile EEPROM (IVR) data the LSB of the Control Register (CR) must be set to 1, then the data of the selected memory can be read.

To write data into the non-volatile EEPROM (IVR) all data registers (00h ~ 0Ch) must be programmed first and then the MSB (WED) of the Control Register (CR) must be set to 1. A dead time of 50ms is initiated during which all the register data (00h ~ 0Ch) is stored into the non-volatile EEPROM. It is not possible to write single DAC register data to the EEPROM. There should be not data flow at the I²C bus during that time because the I²C interface of the TPS65177/A is momentarily not responding. When the 50ms have passed the WED bit is automatically reset to 0.

Programming (continued)

7.6.4 Write Operation

7.6.4.1 Write Single Byte to the DAC Register (DR):

1. Master sends START condition on the bus
2. Master sends the TPS65177/A address 010000A₀ and R \overline{W} bit = Low
TPS65177/A will Acknowledge this byte
3. Send DAC register address (e.g. 01h, address of V_{AVDD})
TPS65177/A will Acknowledge this byte
4. Send the data byte to be written to the DAC register
TPS65177/A will Acknowledge this byte
5. Master sends STOP condition on the bus

Example: Writing 0Fh (15 V) to the DAC address 01h (Boost converter V_(AVDD))

START	0	1	0	0	0	0	A ₀	0	SLAVE ACK	0	0	0	0	0	0	0	1	SLAVE ACK	0	0	0	0	1	1	1	1	SLAVE ACK	STOP
-------	---	---	---	---	---	---	----------------	---	-----------	---	---	---	---	---	---	---	---	-----------	---	---	---	---	---	---	---	---	-----------	------

7.6.4.2 Write Multiple Bytes to the DAC Register (DR):

1. Master sends START condition on the bus
2. Master sends the TPS65177/A address 010000A₀ and R \overline{W} bit = Low
TPS65177/A will Acknowledge this byte
3. Send DAC register address (e.g. 01h, address of V_{AVDD})
TPS65177/A will Acknowledge this byte
4. Send the data byte to be written to the DAC register
TPS65177/A will Acknowledge this byte
5. Master continues sending data bytes to be written to the DA registers
(DAC register address pointer will automatically increase)
6. Master sends STOP condition on the bus

Example: Writing 0Fh, 05h, 00h to the DAC addresses 01h, 02h, 03h (V_(AVDD), HVS, Current limit)

START	0	1	0	0	0	0	A ₀	0	SLAVE ACK	0	0	0	0	0	0	0	1	SLAVE ACK	0	0	0	0	1	1	1	1	SLAVE ACK	
	0	0	0	0	0	1	0	1	SLAVE ACK	0	0	0	0	0	0	0	0	STOP										

7.6.4.3 Write All DAC Register (DR) Data to EEPROM (EE):

1. Master sends START condition on the bus
2. Master sends the TPS65177/A address 010000A₀ and R \overline{W} bit = Low
TPS65177/A will Acknowledge this byte
3. Send Control register (CR) address of FFh
TPS65177/A will Acknowledge this byte
4. Send 1xxxxxx to enable data copy from DAC registers (DR) to EEPROM (EE)
TPS65177/A will Acknowledge this byte
5. Master sends STOP condition on the bus

Example: Writing all DAC registers data to the EEPROM

START	0	1	0	0	0	0	A ₀	0	SLAVE ACK	1	1	1	1	1	1	1	1	SLAVE ACK	1	x	x	x	x	x	x	x	SLAVE ACK	STOP
-------	---	---	---	---	---	---	----------------	---	-----------	---	---	---	---	---	---	---	---	-----------	---	---	---	---	---	---	---	---	-----------	------

7.6.5 READ OPERATION

7.6.5.1 Read single data from DAC register (DR):

1. Master sends START condition on the bus
2. Master sends the TPS65177/A address 010000A₀ and R/W bit = Low
TPS65177/A will Acknowledge this byte
3. Send Control register (CR) address of FFh
TPS65177/A will Acknowledge this byte
4. Send data byte of 00h (EE/ \overline{DR} bit) to specify that the data is read from the DAC register
TPS65177/A will Acknowledge this byte
5. Master sends STOP condition on the bus
6. Master sends START condition on the bus
7. Master sends the TPS65177/A address 010000A₀ and R/W bit = Low
TPS65177/A will Acknowledge this byte
8. Send desired DAC register address to be read (00h~0Ch or FEh)
TPS65177/A will Acknowledge this byte
9. Master re-sends START condition on the bus
10. Master sends the TPS65177/A address 010000A₀ and R/W bit = High
TPS65177/A will Acknowledge this byte
11. Read data from DAC register
Master will not-Acknowledge this byte
12. Master sends STOP condition on the bus

Example: Reading data from the DAC register (DR) address 01h (V_(AVDD))

START	0	1	0	0	0	0	A ₀	0	SLAVE ACK	1	1	1	1	1	1	1	1	SLAVE ACK	0	0	0	0	0	0	0	0	SLAVE ACK	STOP				
START	0	1	0	0	0	0	A ₀	0	SLAVE ACK	0	0	0	0	0	0	0	0	1	SLAVE ACK													
START	0	1	0	0	0	0	A ₀	1	SLAVE ACK	D	D	D	D	D	D	D	D	MASTER N-ACK	STOP													

7.6.5.2 Read Multiple Data from DAC Register (DR):

1. Master sends START condition on the bus
2. Master sends the TPS65177/A address 010000A₀ and R/W bit = Low
TPS65177/A will Acknowledge this byte
3. Send Control register (CR) address of FFh
TPS65177/A will Acknowledge this byte
4. Send data byte of 00h (EE/ \overline{DR} bit) to specify that the data is read from the DAC register
TPS65177/A will Acknowledge this byte
5. Master sends STOP condition on the bus
6. Master sends START condition on the bus
7. Master sends the TPS65177/A address 010000A₀ and R/W bit = Low
TPS65177/A will Acknowledge this byte
8. Send desired DAC register address to be read (00h~0Ch or FEh)
TPS65177/A will Acknowledge this byte
9. Master re-sends START condition on the bus
10. Master sends the TPS65177/A address 010000A₀ and R/W bit = High
TPS65177/A will Acknowledge this byte
11. Continue read data from the DAC register, the address pointer will increase automatically
Master will not-Acknowledge this byte
12. Master will not-acknowledge (N-ACK) after received the last reading data
13. Master sends STOP condition on the bus

 Writing 0Fh, 05h, 00h to the DAC addresses 01h, 02h, 03h (V_(AVDD), HVS, Current limit)

START	0	1	0	0	0	0	A ₀	0	SLAVE ACK	1	1	1	1	1	1	1	1	SLAVE ACK	0	0	0	0	0	0	0	0	0	SLAVE ACK	STOP
START	0	1	0	0	0	0	A ₀	0	SLAVE ACK	0	0	0	0	0	0	0	0	1	SLAVE ACK										
START	0	1	0	0	0	0	A ₀	1	SLAVE ACK	D	D	D	D	D	D	D	D	MASTER ACK	D	D	D	D	D	D	D	D	D	MASTER ACK	
	D	D	D	D	D	D	D	D	MASTER N-ACK	STOP																			

7.6.5.3 Read Single Data to EEPROM (EE):

1. Master sends START condition on the bus
2. Master sends the TPS65177/A address 010000A₀ and R/W bit = Low
TPS65177/A will Acknowledge this byte
3. Send Control register (CR) address of FFh
TPS65177/A will Acknowledge this byte
4. Send data byte of 00h (EE/ \overline{DR} bit) to specify that the data is read from the EEPROM
TPS65177/A will Acknowledge this byte
5. Master sends STOP condition on the bus
6. Master sends START condition on the bus
7. Master sends the TPS65177/A address 010000A₀ and R/W bit = Low
TPS65177/A will Acknowledge this byte
8. Send desired EEPROM register address to be read (00h~0Ch or FEh)
TPS65177/A will Acknowledge this byte
9. Master re-sends START condition on the bus
10. Master sends the TPS65177/A address 010000A₀ and R/W bit = High
TPS65177/A will Acknowledge this byte
11. Read data from EEPROM
Master will not-Acknowledge this byte
12. Master sends STOP condition on the bus

Example: Reading data from the EEPROM (EE) addresses 01h, 02h, 03h (V_(AVDD), HVS, Current limit)

START	0	1	0	0	0	0	0	A ₀	0	SLAVE ACK	1	1	1	1	1	1	1	1	SLAVE ACK	0	0	0	0	0	0	0	1	SLAVE ACK	STOP
START	0	1	0	0	0	0	0	A ₀	0	SLAVE ACK	0	0	0	0	0	0	0	1	SLAVE ACK										
START	0	1	0	0	0	0	0	A ₀	0	SLAVE ACK	D	D	D	D	D	D	D	D	MASTER N-ACK	STOP									

7.6.5.4 Read Multiple Data to EEPROM (EE):

1. Master sends START condition on the bus
2. Master sends the TPS65177/A address 010000A₀ and R \overline{W} bit = Low
TPS65177/A will Acknowledge this byte
3. Send Control register (CR) address of FFh
TPS65177/A will Acknowledge this byte
4. Send data byte of 00h (EE/ \overline{DR} bit) to specify that the data is read from the EEPROM
TPS65177/A will Acknowledge this byte
5. Master sends STOP condition on the bus
6. Master sends START condition on the bus
7. Master sends the TPS65177/A address 010000A₀ and R \overline{W} bit = Low
TPS65177/A will Acknowledge this byte
8. Send desired EEPROM register address to be read (00h~0Ch or FEh)
TPS65177/A will Acknowledge this byte
9. Master re-sends START condition on the bus
10. Master sends the TPS65177/A address 010000A₀ and R \overline{W} bit = High
TPS65177/A will Acknowledge this byte
11. Continue read data from the EEPROM, the address pointer will increase automatically
Master will not-Acknowledge this byte
12. Master will not-acknowledge (N-ACK) after received the last reading data
13. Master sends STOP condition on the bus

Example: Reading data from the EEPROM (EE) addresses 01h, 02h, 03h (V_(AVDD), HVS, Current limit)

START	0	1	0	0	0	0	A ₀	0	SLAVE ACK	1	1	1	1	1	1	1	1	SLAVE ACK	0	0	0	0	0	0	0	1	SLAVE ACK	STOP
START	0	1	0	0	0	0	A ₀	0	SLAVE ACK	0	0	0	0	0	0	0	1	SLAVE ACK										
START	0	1	0	0	0	0	A ₀	1	SLAVE ACK	D	D	D	D	D	D	D	D	MASTER N-ACK	D	D	D	D	D	D	D	D	MASTER ACK	
	D	D	D	D	D	D	D	D	MASTER N-ACK	STOP																		

7.6.6 Write Single Data to DAC:

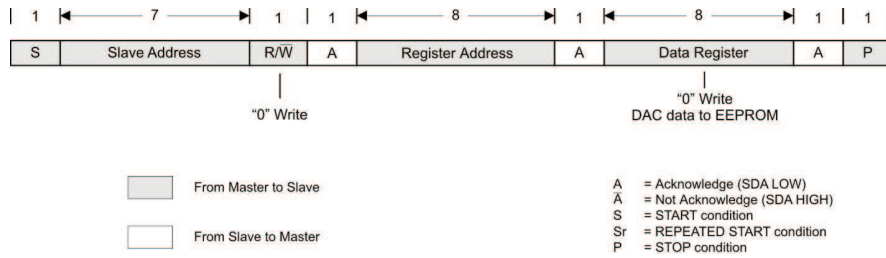

7.6.7 Write Multiple Data to DAC (Auto Increment Address):

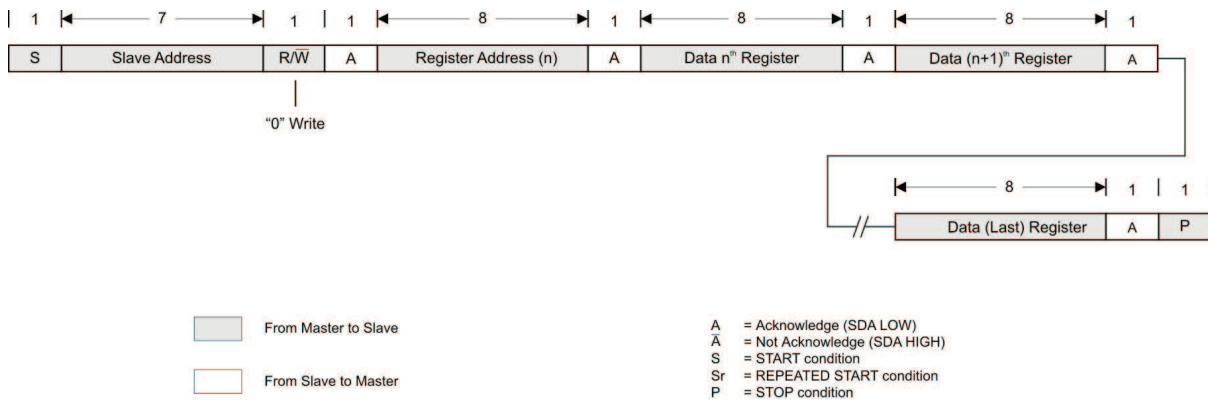

7.6.8 Write all DAC Data to EEPROM:

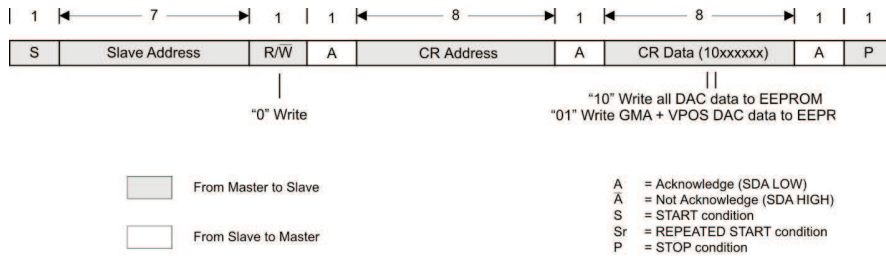

7.6.9 Read Single Data From DAC / EEPROM:

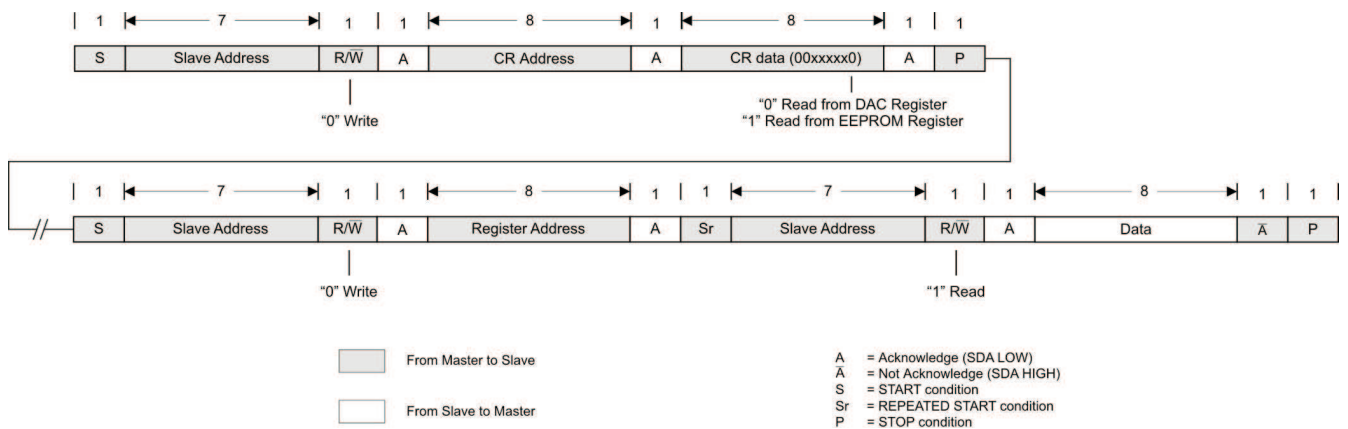

7.6.10 Read Multiple Data fFom DAC / EEPROM (Auto Increment Address):

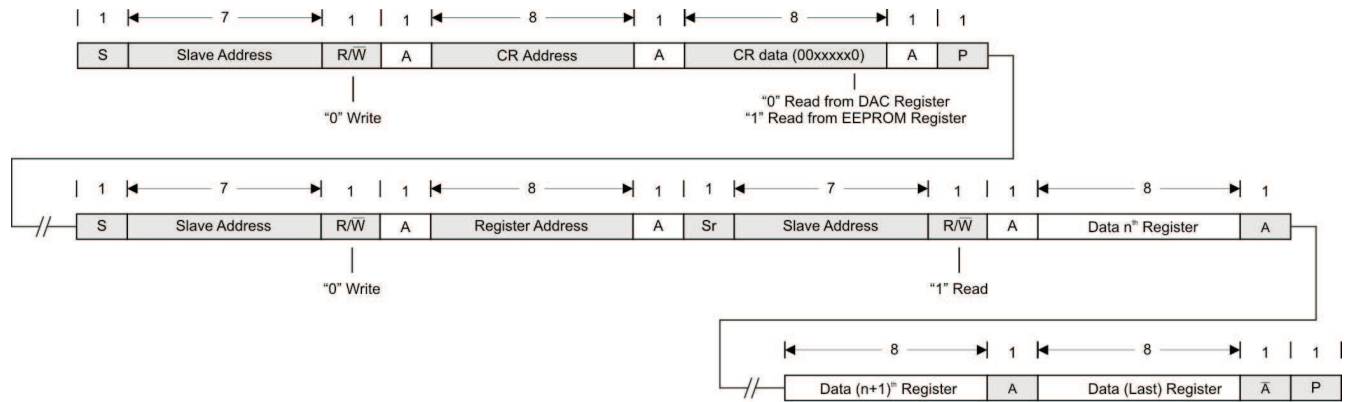

From Master to Slave
 From Slave to Master

A = Acknowledge (SDA LOW)
 \bar{A} = Not Acknowledge (SDA HIGH)
 S = START condition
 Sr = REPEATED START condition
 P = STOP condition

7.7 Register Map

7.7.1 Registers and DAC Settings

Table 3. Device address with A0 selection pin (A0 = 0 or 1)

MSB	TPS65177/A Address						LSB
0	1	0	0	0	0	A0	R/ \overline{W}

Table 4. Control Register FFh (Factory value 00h)

MSB	Address FFh						LSB
WED (Write EEPROM Data)	Reserved	Reserved	Reserved	Reserved	Reserved	Reserved	EE/ \overline{DR} (Read EEPROM or DR)

Table 5. Register Map

Register	Name	Address	Factory value	Bit count	Steps count
Channel	Channel Disable	00h	00h	6	64
Boost	Output voltage $V_{(AVDD)}$	01h	0Fh	6	64
	HVS offset	02h	05h	4	16
	Current Limit	03h	00h	3	8
	Soft-start time	04h	00h	1	2
Buck 1	Output voltage $V_{(IO)}$	05h	03h	4	16
Buck 2	Output voltage $V_{(CORE)}$	06h	02h	5	32
Buck 3	Output voltage $V_{(HAVDD)}$	07h	1Bh	6	64
Pos. CP	Output voltage $V_{(GH_L)}$	08h	08h	4	16
	$V_{(GH_L)}$ to $V_{(GH_H)}$ offset voltage $V_{(GH_OFS)}$	09h	04h	4	16
GPM	GPM limit voltage	0Ah	00h	2	4
Neg. CP	Output voltage $V_{(GL)}$	0Bh	04h	4	16
Buck 3	HVS offset	0Ch	00h	4	16
Memory	Memory write remain time	FEh	Fh	4	16
Control	Control register	FFh	00h	8	256

7.7.1.1 Channel Register (with factory value) – 00h (00h)

MSB	Address 00h						LSB
Reserved	Reserved	0	0	0	0	0	0

MSB	Address 00h						LSB
Reserved	Reserved	$V_{(CORE)}$ Enable: 0 Disable: 1	$V_{(HAVDD)}$ Enable: 0 Disable: 1	$V_{(GH)}$ Enable: 0 Disable: 1	$V_{(GL)}$ Enable: 0 Disable: 1	GPM Enable: 0 Disable: 1	NTC Enable: 0 Disable: 1

7.7.1.2 Boost Output Voltage $V_{(AVDD)}$ Register (with factory value) – 01h (0Fh)

MSB	Address 01h						LSB
Reserved	Reserved	0	0	1	1	1	1

DAC Value	$V_{(AVDD)}$	DAC Value	$V_{(AVDD)}$	DAC Value	$V_{(AVDD)}$	DAC Value	$V_{(AVDD)}$
00h	13.5 V	10h	15.1 V	20h	16.7 V	30h	18.3 V
01h	13.6 V	11h	15.2 V	21h	16.8 V	31h	18.4 V
02h	13.7 V	12h	15.3 V	22h	16.9 V	32h	18.5 V
03h	13.8 V	13h	15.4 V	23h	17.0 V	33h	18.6 V
04h	13.9 V	14h	15.5 V	24h	17.1 V	34h	18.7 V

DAC Value	V _(AVDD)	DAC Value	V _(AVDD)	DAC Value	V _(AVDD)	DAC Value	V _(AVDD)
05h	14.0 V	15h	15.6 V	25h	17.2 V	35h	18.8 V
06h	14.1 V	16h	15.7 V	26h	17.3 V	36h	18.9 V
07h	14.2 V	17h	15.8 V	27h	17.4 V	37h	19.0 V
08h	14.3 V	18h	15.9 V	28h	17.5 V	38h	19.1 V
09h	14.4 V	19h	16.0 V	29h	17.6 V	39h	19.2 V
0Ah	14.5 V	1Ah	16.1 V	2Ah	17.7 V	3Ah	19.3 V
0Bh	14.6 V	1Bh	16.2 V	2Bh	17.8 V	3Bh	19.4 V
0Ch	14.7 V	1Ch	16.3 V	2Ch	17.9 V	3Ch	19.5 V
0Dh	14.8 V	1Dh	16.4 V	2Dh	18.0 V	3Dh	19.6 V
0Eh	14.9 V	1Eh	16.5 V	2Eh	18.1 V	3Eh	19.7 V
0Fh	15.0 V	1Fh	16.6 V	2Fh	18.2 V	3Fh	19.8 V

7.7.1.3 Boost HVS Offset Voltage Register (with factory value) – 02h (05h)

MSB	Address 01h						LSB
Reserved	Reserved	Reserved	Reserved	0	1	0	1

DAC Value	V _(OFFSET)	DAC Value	V _(OFFSET)	DAC Value	V _(OFFSET)	DAC Value	V _(OFFSET)
00h	0.0 V	04h	0.8 V	08h	1.6 V	0Ch	2.4 V
01h	0.2 V	05h	1.0 V	09h	1.8 V	0Dh	2.6 V
02h	0.4 V	06h	1.2 V	0Ah	2.0 V	0Eh	2.8 V
03h	0.6 V	07h	1.4 V	0Bh	2.2 V	0Fh	3.0 V

7.7.1.4 Boost Current Limit Negative Offset Current Register (with factory value) – 03h (00h)

MSB	Address 03h						LSB
Reserved	Reserved	Reserved	Reserved	Reserved	0	0	0

DAC Value	I _(OFFSET)	DAC Value	I _(OFFSET)	DAC Value	I _(OFFSET)	DAC Value	I _(OFFSET)
00h	0.0 A	02h	0.8 A	04h	1.6 A	06h	2.4 A
01h	0.4 A	03h	1.2 A	05h	2.0 A	07h	2.8 A

7.7.1.5 Boost Soft-start Time Register (with factory value) – 04h (00h)

MSB	Address 04h						LSB
Reserved	Reserved	Reserved	Reserved	Reserved	Reserved	Reserved	0

DAC Value	Time
00h	10 ms
01h	20 ms

7.7.1.6 Buck 1 Output Voltage V_(IO) Register (with factory value) – 05h (03h):

MSB	Address 05h						LSB
Reserved	Reserved	Reserved	Reserved	0	0	1	1

DAC Value	V _(IO)	DAC Value	V _(IO)	DAC Value	V _(IO)	DAC Value	V _(IO)
00h	2.2 V	04h	2.6 V	08h	3.0 V	0Ch	3.4 V
01h	2.3 V	05h	2.7 V	09h	3.1 V	0Dh	3.5 V
02h	2.4 V	06h	2.8 V	0Ah	3.2 V	0Eh	3.6 V
03h	2.5 V	07h	2.9 V	0Bh	3.3 V	0Fh	3.7 V

7.7.1.7 Buck 2 Output Voltage $V_{(CORE)}$ Register (with factory value) – 06h (02h)

MSB	Address 06h						LSB
Reserved	Reserved	Reserved	0	0	0	1	0

DAC Value	$V_{(CORE)}$	DAC Value	$V_{(CORE)}$	DAC Value	$V_{(CORE)}$	DAC Value	$V_{(CORE)}$
00h	0.8 V	07h	1.5 V	0Eh	2.2 V	15h	2.9 V
01h	0.9 V	08h	1.6 V	0Fh	2.3 V	16h	3.0 V
02h	1.0 V	09h	1.7 V	10h	2.4 V	17h	3.1 V
03h	1.1 V	0Ah	1.8 V	11h	2.5 V	18h	3.2 V
04h	1.2 V	0Bh	1.9 V	12h	2.6 V	19h	3.3 V
05h	1.3 V	0Ch	2.0 V	13h	2.7 V		
06h	1.4 V	0Dh	2.1 V	14h	2.8 V		

7.7.1.8 Buck 3 Output Voltage $V_{(HAVDD)}$ Register (with factory value) – 07h (1Bh)

MSB	Address 07h						LSB
Reserved	Reserved	0	1	1	0	1	1

DAC Value	$V_{(HAVDD)}$	DAC Value	$V_{(HAVDD)}$	DAC Value	$V_{(HAVDD)}$	DAC Value	$V_{(HAVDD)}$
00h	4.8 V	10h	6.4 V	20h	8.0 V	30h	9.6 V
01h	4.9 V	11h	6.5 V	21h	8.1 V	31h	9.7 V
02h	5.0 V	12h	6.6 V	22h	8.2 V	32h	9.8 V
03h	5.1 V	13h	6.7 V	23h	8.3 V	33h	9.9 V
04h	5.2 V	14h	6.8 V	24h	8.4 V	34h	10.0 V
05h	5.3 V	15h	6.9 V	25h	8.5 V	35h	10.1 V
06h	5.4 V	16h	7.0 V	26h	8.6 V	36h	10.2 V
07h	5.5 V	17h	7.1 V	27h	8.7 V	37h	10.3 V
08h	5.6 V	18h	7.2 V	28h	8.8 V	38h	10.4 V
09h	5.7 V	19h	7.3 V	29h	8.9 V	39h	10.5 V
0Ah	5.8 V	1Ah	7.4 V	2Ah	9.0 V	3Ah	10.6 V
0Bh	5.9 V	1Bh	7.5 V	2Bh	9.1 V	3Bh	10.7 V
0Ch	6.0 V	1Ch	7.6 V	2Ch	9.2 V	3Ch	10.8 V
0Dh	6.1 V	1Dh	7.7 V	2Dh	9.3 V	3Dh	10.9 V
0Eh	6.2 V	1Eh	7.8 V	2Eh	9.4 V	3Eh	11.0 V
0Fh	6.3 V	1Fh	7.9 V	2Fh	9.5 V	3Fh	11.1 V

7.7.1.9 Pos. Charge Pump Low Output Voltage $V_{(GH_L)}$ Register (with factory value) – 08h (08h):

MSB	Address 08h						LSB
Reserved	Reserved	Reserved	Reserved	1	0	0	0

DAC Value	$V_{(GH_L)}$	DAC Value	$V_{(GH_L)}$	DAC Value	$V_{(GH_L)}$	DAC Value	$V_{(GH_L)}$
00h	20 V	04h	24 V	08h	28 V	0Ch	32 V
01h	21 V	05h	25 V	09h	29 V	0Dh	33 V
02h	22 V	06h	26 V	0Ah	30 V	0Eh	34 V
03h	23 V	07h	27 V	0Bh	31 V	0Fh	35 V

7.7.1.10 Positive Charge Pump Low Output Voltage $V_{(GH_L)}$ to $V_{(GH_H)}$ Positive Offset Voltage $V_{(GH_OFS)}$ Register (with factory value) – 09h (04h):

MSB	Address 09h						LSB
Reserved	Reserved	Reserved	Reserved	0	1	0	0

DAC Value	$V_{(GH_L)}$	DAC Value	$V_{(GH_L)}$	DAC Value	$V_{(GH_L)}$	DAC Value	$V_{(GH_L)}$
00h	0 V	04h	4 V	08h	8 V	0Ch	12 V
01h	1 V	05h	5 V	09h	9 V	0Dh	13 V
02h	2 V	06h	6 V	0Ah	10 V	0Eh	14 V
03h	3 V	07h	7 V	0Bh	11 V	0Fh	15 V

7.7.1.11 Gate Pulse Modulation Limit Voltage Register (with factory value) – 0Ah (00h)

MSB	Address 0Ah						LSB
Reserved	Reserved	Reserved	Reserved	Reserved	Reserved	0	0

DAC Value	Limit	DAC Value	Limit
00h	0 V	02h	10 V
01h	5 V	03h	15 V

7.7.1.12 Negative Charge Pump Output Voltage $V_{(GL)}$ Register (with factory value) – 0Bh (04h)

MSB	Address 05h						LSB
Reserved	Reserved	Reserved	Reserved	0	1	0	0

DAC Value	$V_{(GL)}$	DAC Value	$V_{(GL)}$	DAC Value	$V_{(GL)}$	DAC Value	$V_{(GL)}$
00h	-5.5 V	04h	-7.9 V	08h	-10.3 V	0Ch	-12.7 V
01h	-6.1 V	05h	-8.5 V	09h	-10.9 V	0Dh	-13.3 V
02h	-6.7 V	06h	-9.1 V	0Ah	-11.5 V	0Eh	-13.9 V
03h	-7.3 V	07h	-9.7 V	0Bh	-12.1 V	0Fh	-14.5 V

7.7.1.13 Buck 3 HVS Offset Voltage Register (with factory value) – 0Ch (00h):

MSB	Address 0Ch						LSB
Reserved	Reserved	Reserved	Reserved	0	0	0	0

DAC Value	$V_{(OFFSET)}$	DAC Value	$V_{(OFFSET)}$	DAC Value	$V_{(OFFSET)}$	DAC Value	$V_{(OFFSET)}$
00h	0.0 V	04h	0.4 V	08h	0.8 V	0Ch	1.2 V
01h	0.1 V	05h	0.5 V	09h	0.9 V	0Dh	1.3 V
02h	0.2 V	06h	0.6 V	0Ah	1.0 V	0Eh	1.4 V
03h	0.3 V	07h	0.7 V	0Bh	1.1 V	0Fh	1.5 V

7.7.1.14 Memory Write Remain Time Register (with factory value) – FEh (0Fh):

MSB	Address FEh						LSB
Reserved	Reserved	Reserved	Reserved	1	1	1	1

DAC Value	Remaining Writes	DAC Value	Remaining Writes	DAC Value	Remaining Writes	DAC Value	Remaining Writes
00h	0	04h	4	08h	8	0Ch	12
01h	1	05h	5	09h	9	0Dh	13
02h	2	06h	6	0Ah	10	0Eh	14
03h	3	07h	7	0Bh	11	0Fh	EEPROM

Typical Applications (continued)

8.2.1 Design Requirements

For this design example, use the values shown in [Table 6](#)

Table 6. Design Parameters

PARAMETER	VALUE
Voltage	$V_I = 12\text{ V}$, $V_{(AVDD)} = 18\text{ V}$, $V_{(HAVDD)} = 9\text{ V}$, $V_{(IO)} = 3.3\text{ V}$, $V_{(CORE)} = 1.2\text{ V}$, $V_{(GH)} = 28\text{ V}$, $V_{(GL)} = -10.3\text{ V}$
Switching Frequency	Boost, Buck 1 = 750 kHz, Buck2, Buck 3 = 1 MHz

8.2.2 Detailed Design Procedure

See the [Device Functional Modes](#) section for the detailed design procedure.

8.2.3 Application Curves

PARAMETER	CONDITIONS	FIGURE
SEQUENCING		
Power-on $V_{(GL)}$ driven by Buck 1 switch node	$V_I = 12\text{ V}$, $V_{(IO)} = 3.3\text{ V}$, $V_{(CORE)} = 1.2\text{ V}$, $V_{(AVDD)} = 18\text{ V}$, $V_{(HAVDD)} = 9\text{ V}$, $V_{(GH)} = 28\text{ V}$, $V_{(GL)} = -10.3\text{ V}$	Figure 20
Power-on $V_{(GL)}$ driven by Boost switch node	$V_I = 12\text{ V}$, $V_{(IO)} = 3.3\text{ V}$, $V_{(CORE)} = 1.2\text{ V}$, $V_{(AVDD)} = 18\text{ V}$, $V_{(HAVDD)} = 9\text{ V}$, $V_{(GH)} = 28\text{ V}$, $V_{(GL)} = -10.3\text{ V}$	Figure 21
Buck 1 Converter ($V_I = 12\text{ V}$, $L = 6.8\text{ }\mu\text{H}$, $C_{OUT} = 30\text{ }\mu\text{F}$)		
Efficiency vs. load current	$V_{(IO)} = 3.3\text{ V}$	Figure 22
PWM switching – light load	$V_{(IO)} = 3.3\text{ V} / 10\text{ mA}$	Figure 23
PWM switching – normal load	$V_{(IO)} = 3.3\text{ V} / 500\text{ mA}$	Figure 24
Load Transient response	$V_{(IO)} = 3.3\text{ V} / 100\text{ mA} \rightarrow 500\text{ mA}$	Figure 25
Buck 2 Converter ($V_I = 3.3\text{ V}$, $L = 4.7\text{ }\mu\text{H}$, $C_{OUT} = 20\text{ }\mu\text{F}$)		
Efficiency vs. load current	$V_{(CORE)} = 1.2\text{ V}$	Figure 26
PWM switching – light load	$V_{(CORE)} = 1.2\text{ V} / 10\text{ mA}$	Figure 27
PWM switching – normal load	$V_{(CORE)} = 1.2\text{ V} / 500\text{ mA}$	Figure 28
Load Transient response	$V_{(CORE)} = 1.2\text{ V} / 10\text{ mA} \rightarrow 300\text{ mA}$	Figure 29
Buck 3 Converter ($V_I = 12\text{ V}$, $L = 6.8\text{ }\mu\text{H}$, $C_{OUT} = 10\text{ }\mu\text{F}$)		
Efficiency vs. load current	$V_{(HAVDD)} = 9\text{ V}$	Figure 30
PWM switching – light load sourcing	$V_{(HAVDD)} = 9\text{ V} / 10\text{ mA}$	Figure 31
PWM switching – light load sinking	$V_{(HAVDD)} = 9\text{ V} / -10\text{ mA}$	Figure 32
PWM switching – normal load sourcing	$V_{(HAVDD)} = 9\text{ V} / 500\text{ mA}$	Figure 33
PWM switching – normal load sinking	$V_{(HAVDD)} = 9\text{ V} / -500\text{ mA}$	Figure 34
Load Transient response	$V_{(HAVDD)} = 9\text{ V} / 0\text{ mA} \rightarrow 300\text{ mA} \rightarrow 0\text{ mA} \rightarrow -350\text{ mA}$	Figure 35
Boost Converter ($V_I = 12\text{ V}$, $L = 6.8\text{ }\mu\text{H}$, $C_{(ISOSW)} = 10\text{ }\mu\text{F}$, $C_{OUT} = 40\text{ }\mu\text{F}$)		
Efficiency vs. load current	$V_{(AVDD)} = 18\text{ V}$	Figure 36
PWM switching – light load	$V_{(AVDD)} = 18\text{ V} / 10\text{ mA}$	Figure 37
PWM switching – normal load	$V_{(AVDD)} = 18\text{ V} / 500\text{ mA}$	Figure 38
Load Transient response	$V_{(AVDD)} = 18\text{ V} / 100\text{ mA} \rightarrow 500\text{ mA}$	Figure 39
Positive Charge-Pump ($V_I = 12\text{ V}$, Diode = BAV99, $R_{(SW)} = 2.2\text{ }\Omega$, Transistor = KTA1666, $C_{OUT} = 4.7\text{ }\mu\text{F}$)		
Light load operation	$V_{(GH)} = 28\text{ V} / 10\text{ mA}$	Figure 40
Normal load operation	$V_{(GH)} = 28\text{ V} / 50\text{ mA}$	Figure 41
Load Transient response	$V_{(GH)} = 28\text{ V} / 10\text{ mA} \rightarrow 50\text{ mA}$	Figure 42
Negative Charge-Pump ($V_I = 12\text{ V}$, Diode = BAV99, $R_{(SW)} = 2.2\text{ }\Omega$, Transistor = KTC4376, $C_{OUT} = 4.7\text{ }\mu\text{F}$)		
Light load operation	$V_{(GL)} = -7.9\text{ V} / 10\text{ mA}$	Figure 43
Normal load operation	$V_{(GL)} = -7.9\text{ V} / 50\text{ mA}$	Figure 44
Load Transient response	$V_{(GL)} = -7.9\text{ V} / 10\text{ mA} \rightarrow 50\text{ mA}$	Figure 45

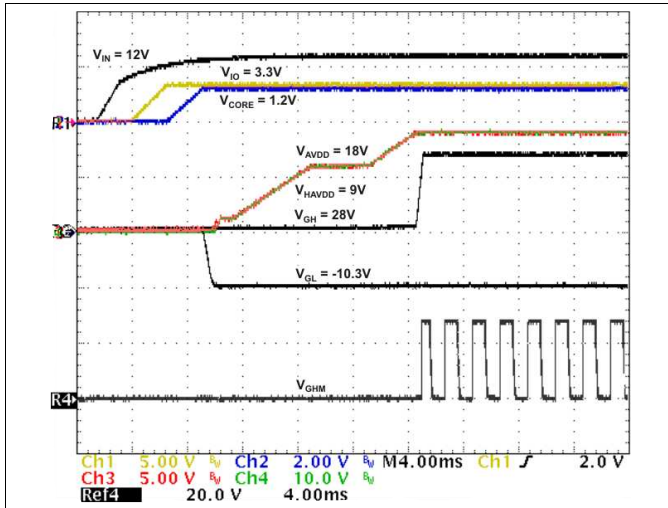

Figure 20. Startup Sequencing $V_{(GL)}$ Driven By Buck 1

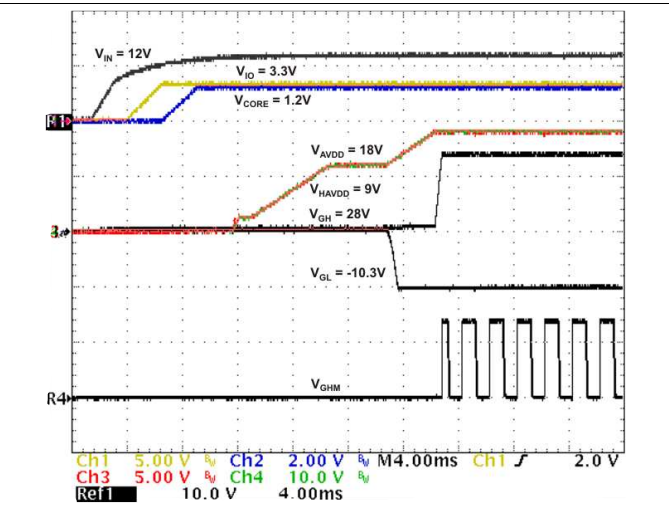

Figure 21. Startup Sequencing $V_{(GL)}$ Driven By Boost

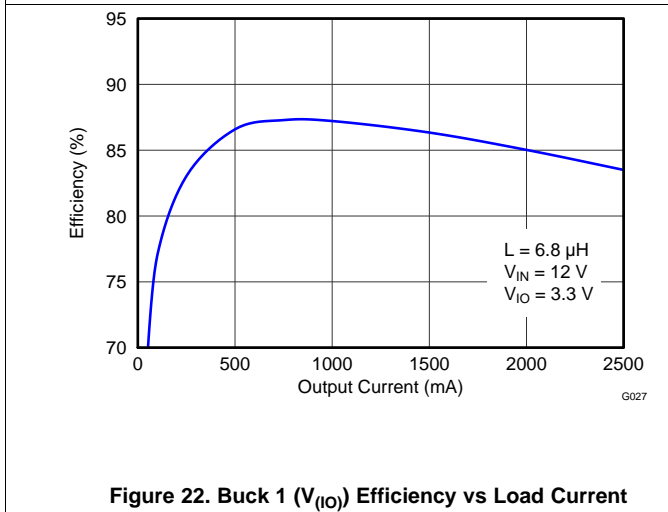

Figure 22. Buck 1 ($V_{(IO)}$) Efficiency vs Load Current

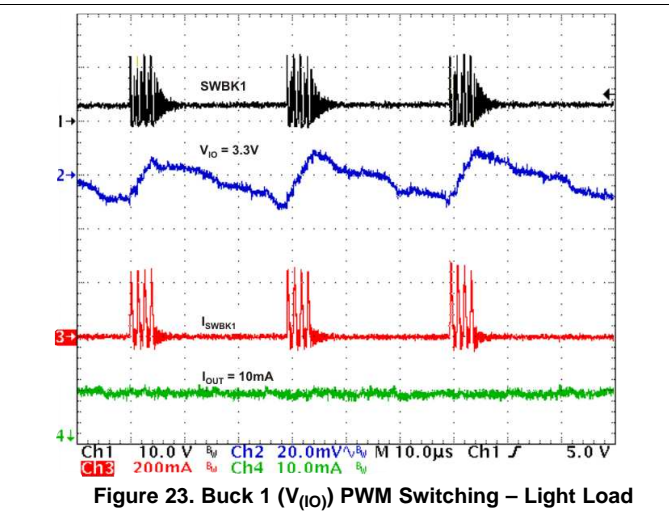

Figure 23. Buck 1 ($V_{(IO)}$) PWM Switching – Light Load

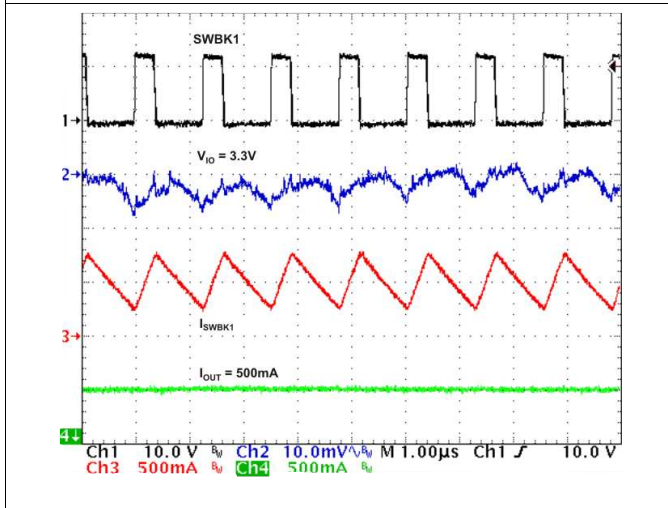

Figure 24. Buck 1 ($V_{(IO)}$) PWM Switching – Normal Load

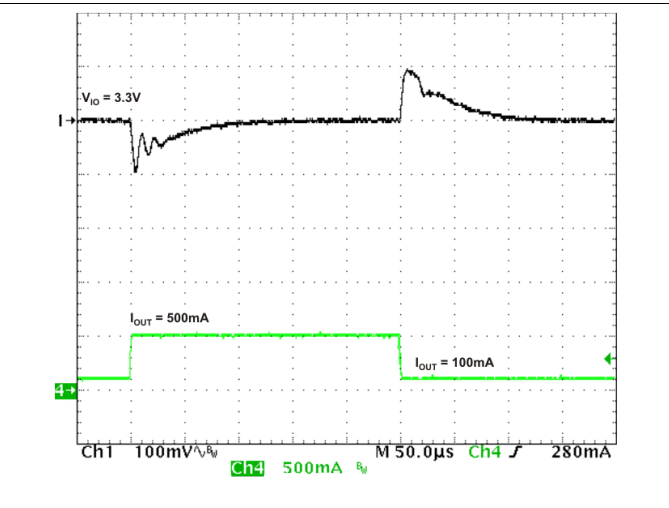

Figure 25. Buck 1 ($V_{(IO)}$) Load Transient Response

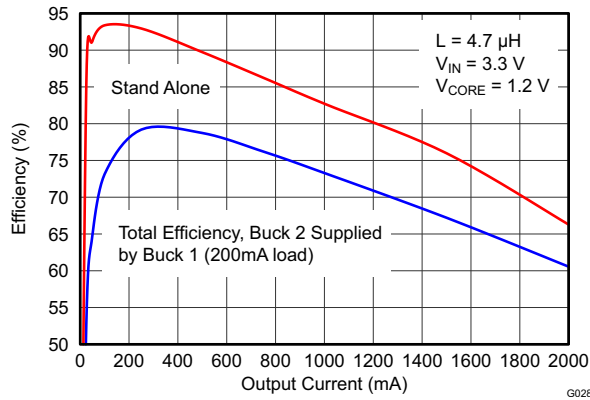

Figure 26. Buck 2 (V_{CORE}) Efficiency vs Load Current

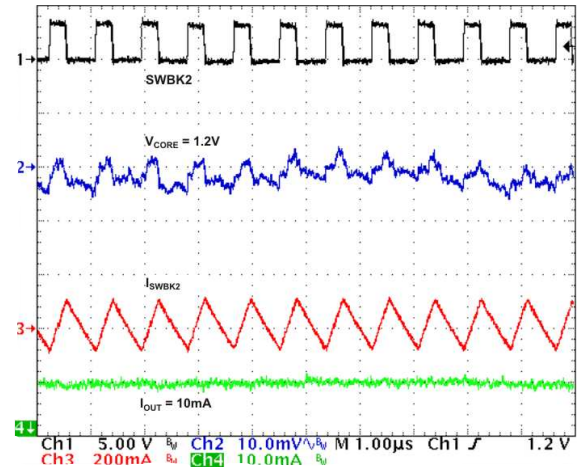

Figure 27. Buck 2 (V_{CORE}) PWM Switching – Light Load

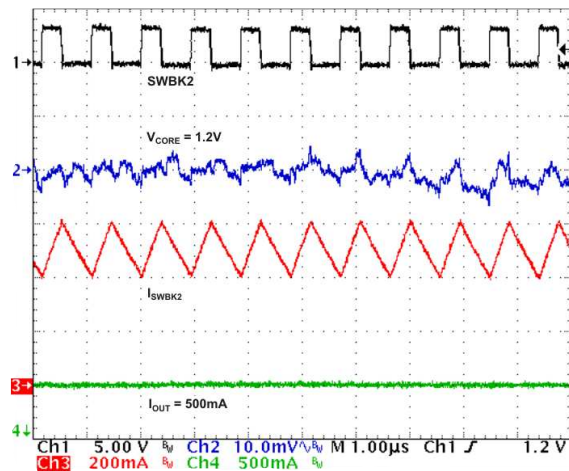

Figure 28. Buck 2 (V_{CORE}) PWM Switching – Normal Load

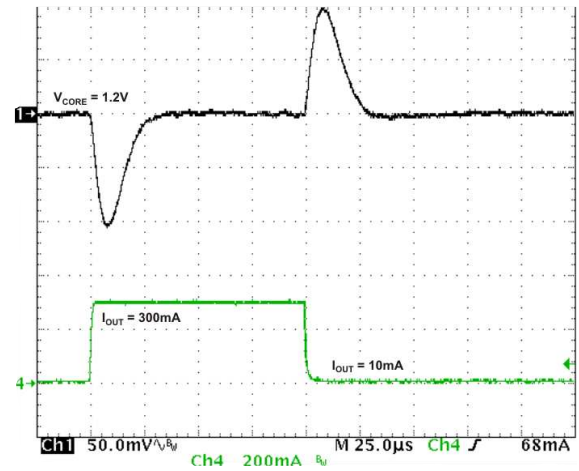

Figure 29. Buck 2 (V_{CORE}) Load Transient Response

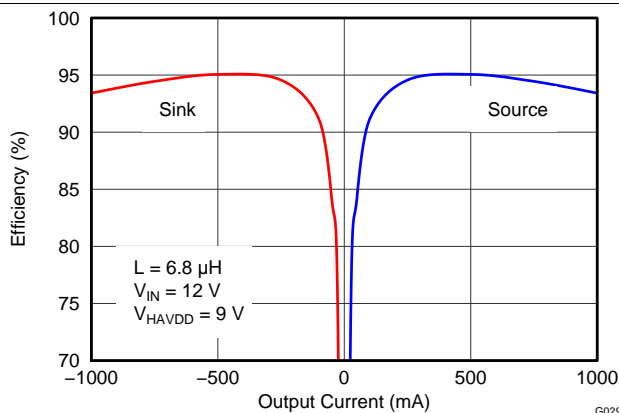

Figure 30. Buck 3 (V_{HAVDD}) Efficiency vs Load Current

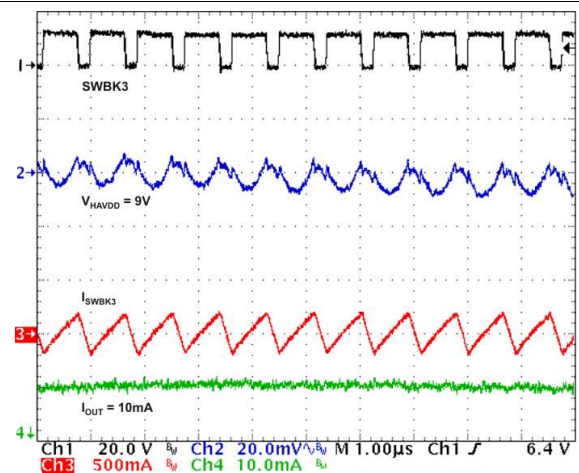

Figure 31. Buck 3 (V_{HAVDD}) PWM – Light Load Source

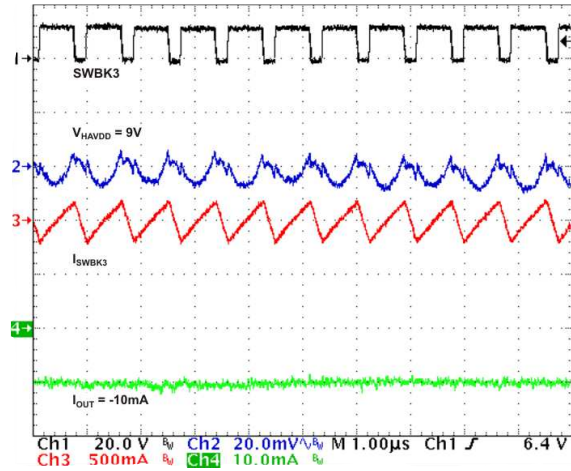

Figure 32. Buck 3 (V_{HAVDD}) PWM – Light Load Sink

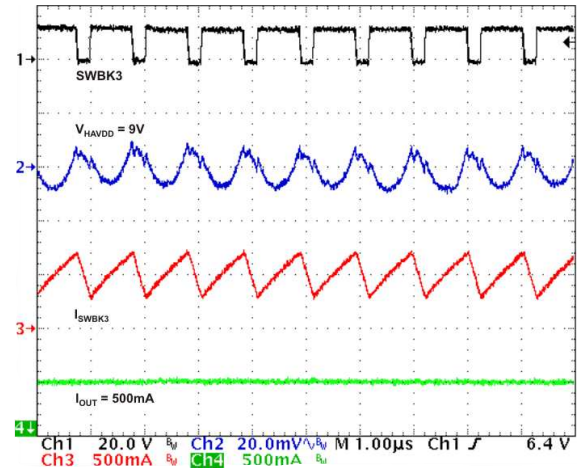

Figure 33. Buck 3 (V_{HAVDD}) PWM – Normal Load Source

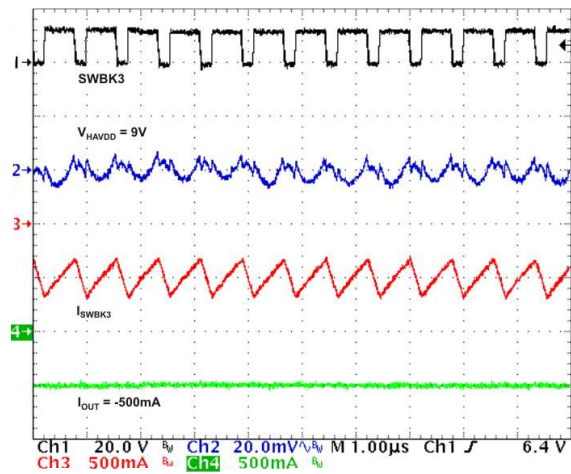

Figure 34. BUCK 3 (V_{HAVDD}) PWM – Normal Load Sink

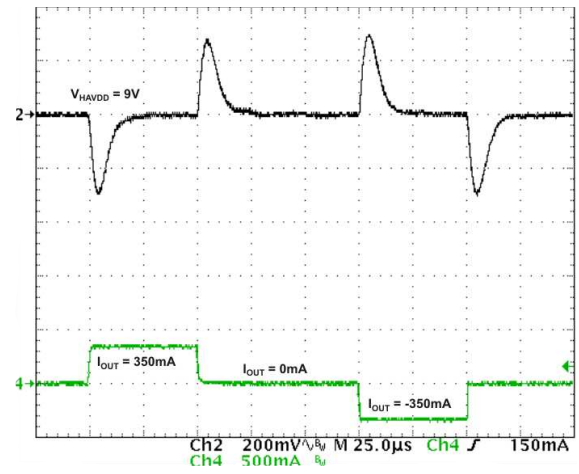

Figure 35. BUCK 3 (V_{HAVDD}) Load Transient Response

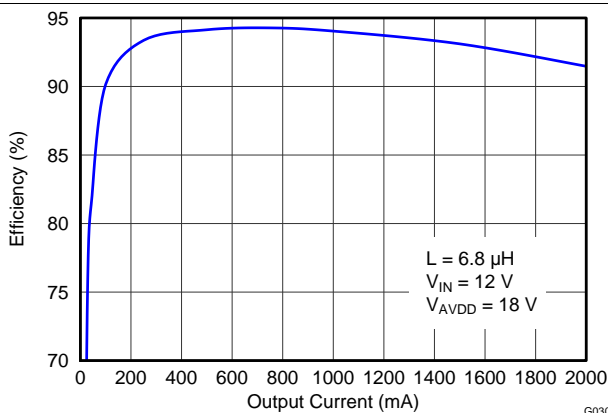

Figure 36. Boost (V_{AVDD}) Efficiency vs Load Current

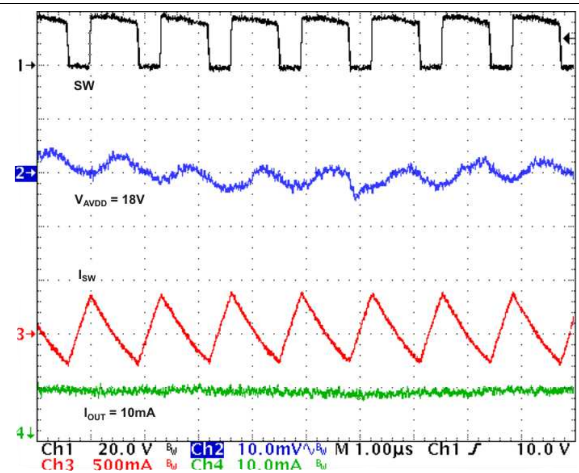

Figure 37. Boost (V_{AVDD}) PWM Switching – Light Load

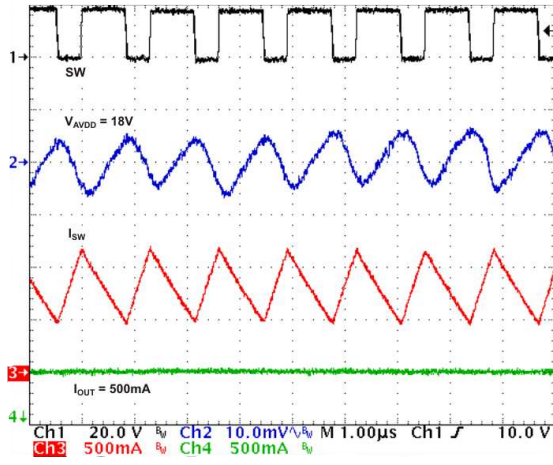

Figure 38. Boost (V_{AVDD}) PWM Switching – Normal Load

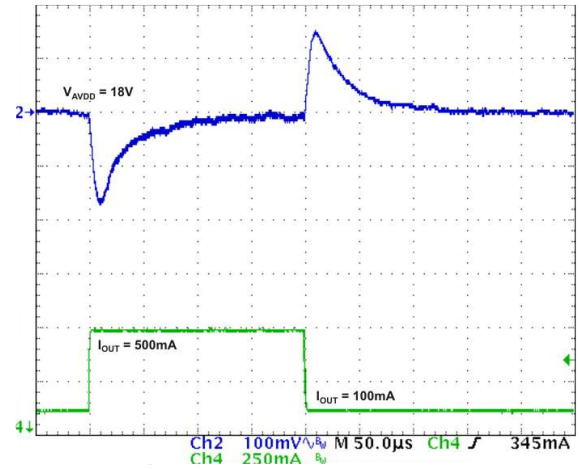

Figure 39. Boost (V_{AVDD}) Load Transient Response

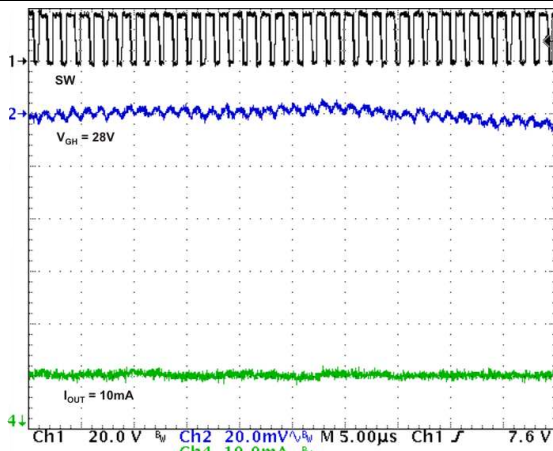

Figure 40. Positive Charge-Pump (V_{GH}) Light Load

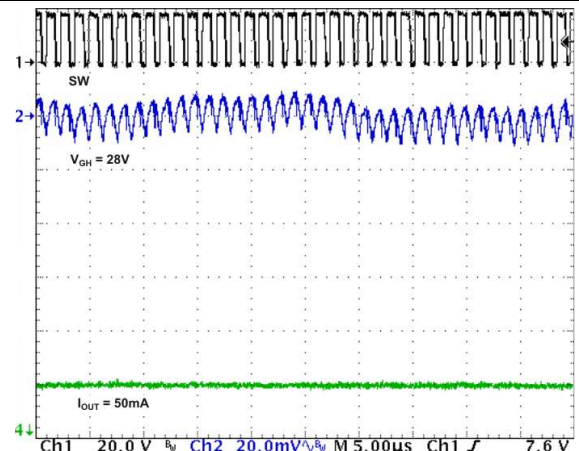

Figure 41. Positive Charge-Pump (V_{GH}) Normal Load

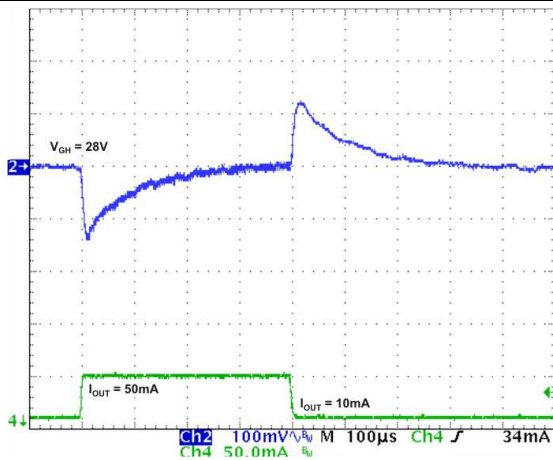

Figure 42. Positive CP (V_{GH}) Load Transient Response

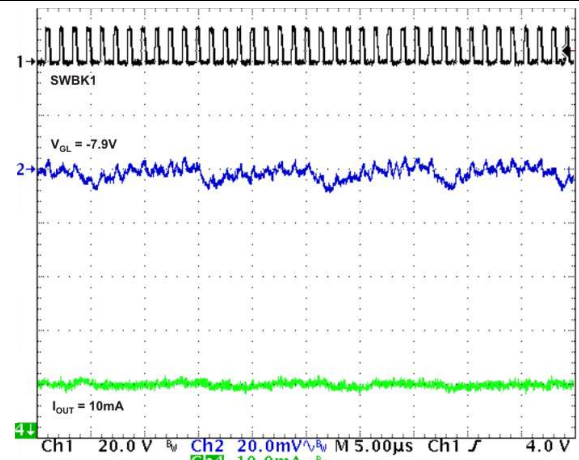
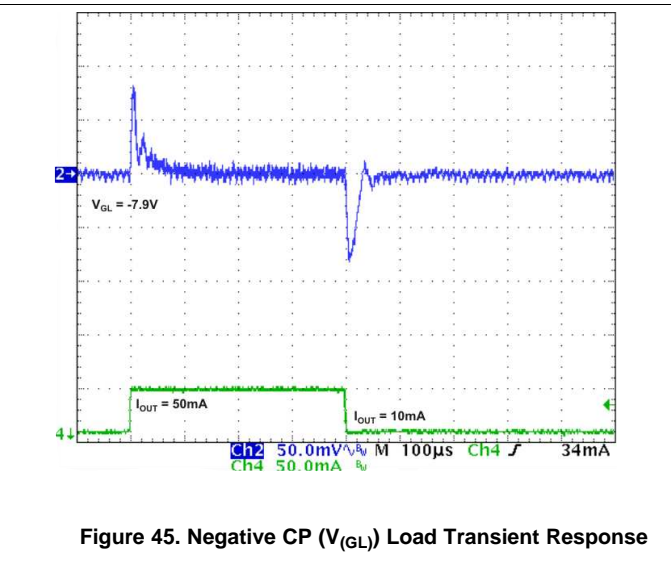
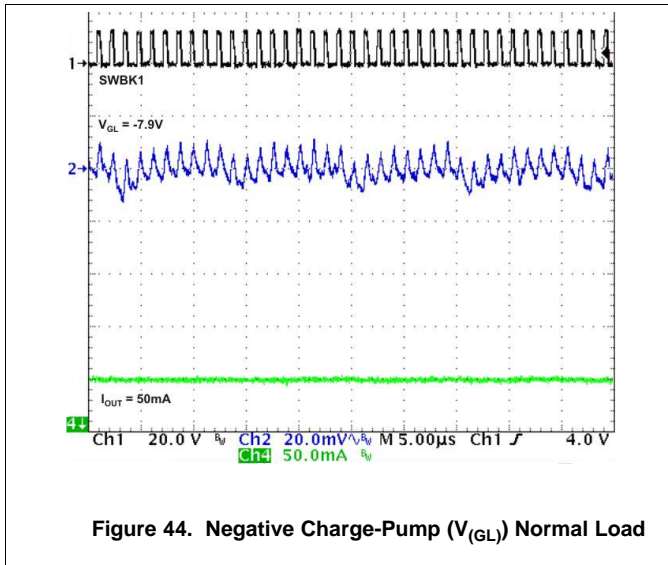

Figure 43. Negative Charge-Pump (V_{GL}) Light Load



8.3 System Examples

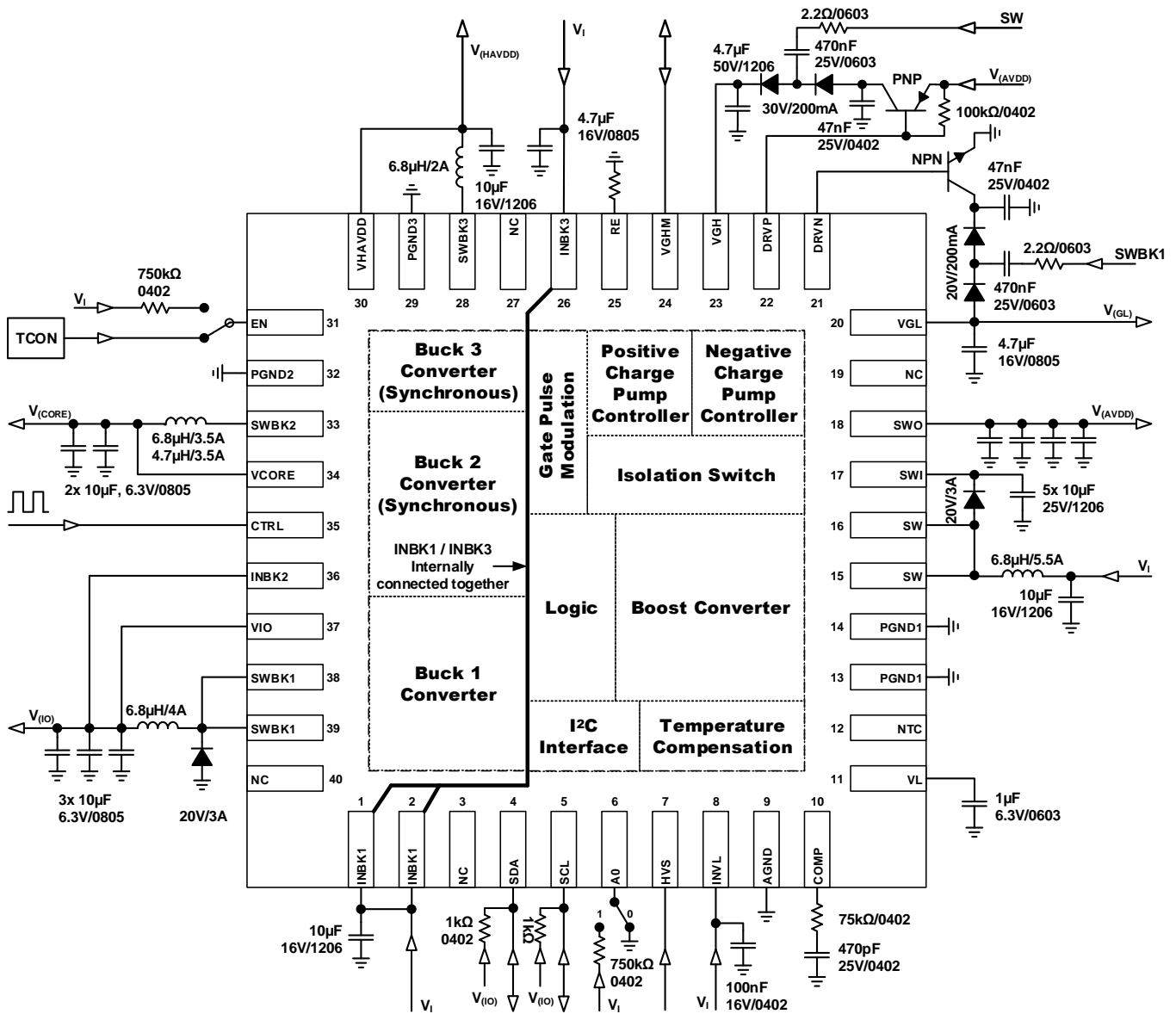

Figure 46. $V_{(GH)}$ Temperature Compensation Disabled (by I²C)

System Examples (continued)

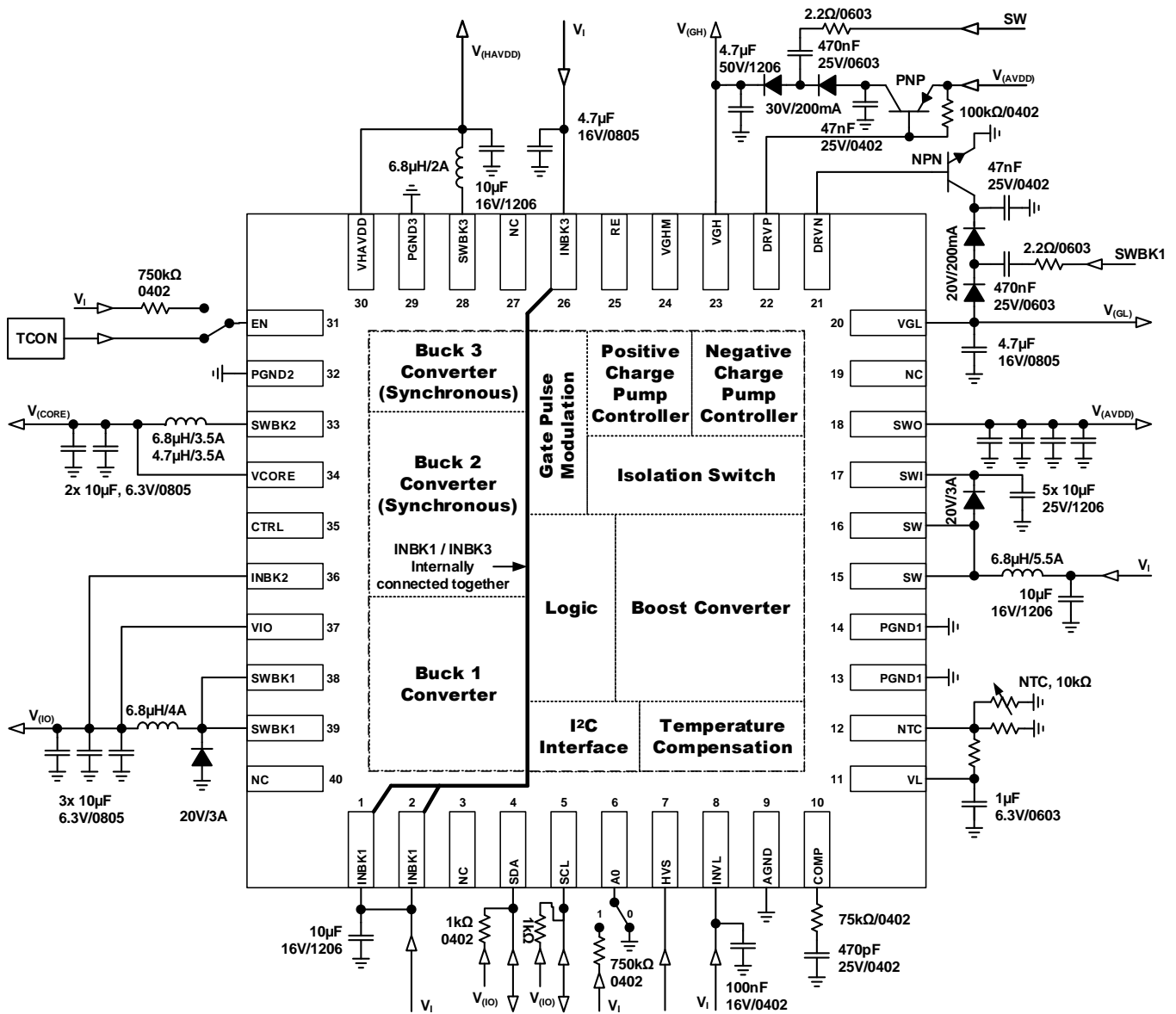

Figure 47. Gate Pulse Modulation Disabled (by I²C)

System Examples (continued)

For best input voltage filtering low ESR ceramic capacitors are recommended. For better input voltage filtering the capacitor values can be increased.

- **Internal logic:** 100 nF close to the INVL-pin
- **Boost converter:** 10 μ F near the inductor
- **Buck 1 converter:** 10 μ F close to the INBK1-pins
- **Buck 2 converter:** 4.7 μ F close to the INBK2-pin (also one of the Buck 2 output capacitors can be used)
- **Buck 3 converter:** 4.7 μ F close to the INBK3-pin

Table 7. Input Capacitor Selection

CAPACITOR	VOLTAGE RATING	TEMPERATURE CHARACTERISTICS	SUPPLIER ⁽¹⁾	COMPONENT CODE
100 nF / 0402	16 V	X5R	Murata	GRM155R61C104KA88
100 nF / 0402	16 V	X5R	Taiyo Yuden	EMK105BJ104KV
4.7 μ F / 0402	6.3 V	X5R	Murata	GRM155R60J475ME87
4.7 μ F / 0402	6.3 V	X5R	Taiyo Yuden	JMK105BBJ475MV
4.7 μ F / 0805	16 V	X5R	Murata	GRM21BR61C475KA88
4.7 μ F / 0805	16 V	X5R	Taiyo Yuden	EMK212ABJ475KG
10 μ F / 1206	16 V	X5R	Murata	GRM31CR61C106KA88
10 μ F / 1206	16 V	X7R	Taiyo Yuden	EMK316AB7106KL

(1) See [Third-Party Products](#) disclaimer.

9 Power Supply Recommendations

The device is designed to operate with input supplies from 8.6 V to 14.7 V. The input supply should be stable and free of noise if the device's full performance is to be achieved.

10 Layout

10.1 Layout Guideline

The PCB layout is a very important step in the power supply design. Following points should be considered.

- Place red marked components first and as close as possible to the device, keep red lines short.
- The bolder the line the wider the trace should be on the PCB because bold lines carry high currents.
- The input capacitors for INBK1, INBK3 and INVL should be placed as close as possible to the IC.
- For $V_{(AVDD)}$ the line SW, Diode, SWI as well as the connection PGND to SWI capacitor should be kept short and low resistive.
- The compensation network for the Boost converter $V_{(AVDD)}$ must be placed as close as possible to the IC and connected by short lines to COMP and AGND to avoid noise coupling.
- For $V_{(IO)}$ the line SWBK1, Diode, GND of INBK1 capacitor should be kept short and low resistive.
- For $V_{(CORE)}$ an additional input capacitor should be used when the $V_{(IO)}$ output capacitor line is longer than 1 cm or a wide connection line is not possible to stabilize the input voltage.
- Feedback lines starting at the output capacitors should be routed through a non noisy area away from switching traces. If possible the feedback lines should be kept short to reduce noise coupling.
- Inductors can be placed further away from the IC to avoid IC heating through the inductor.
- All IC Grounds (AGND, PGNDx) must be connected to the Exposed Thermal PAD.
- Avoid vias in Power lines when possible because of their high inductance and resistance.
- The Exposed Thermal PAD of the QFN package must be soldered to a big GND cooling area. For good thermal conduction to the cooling area as much as possible vias should be used to keep the device cool.
- The thermal resistor NTC should be placed away from heat sources. For most accurate environment temperature measurement the NTC must be placed at the coldest point of the PCB.

10.2 Layout Example

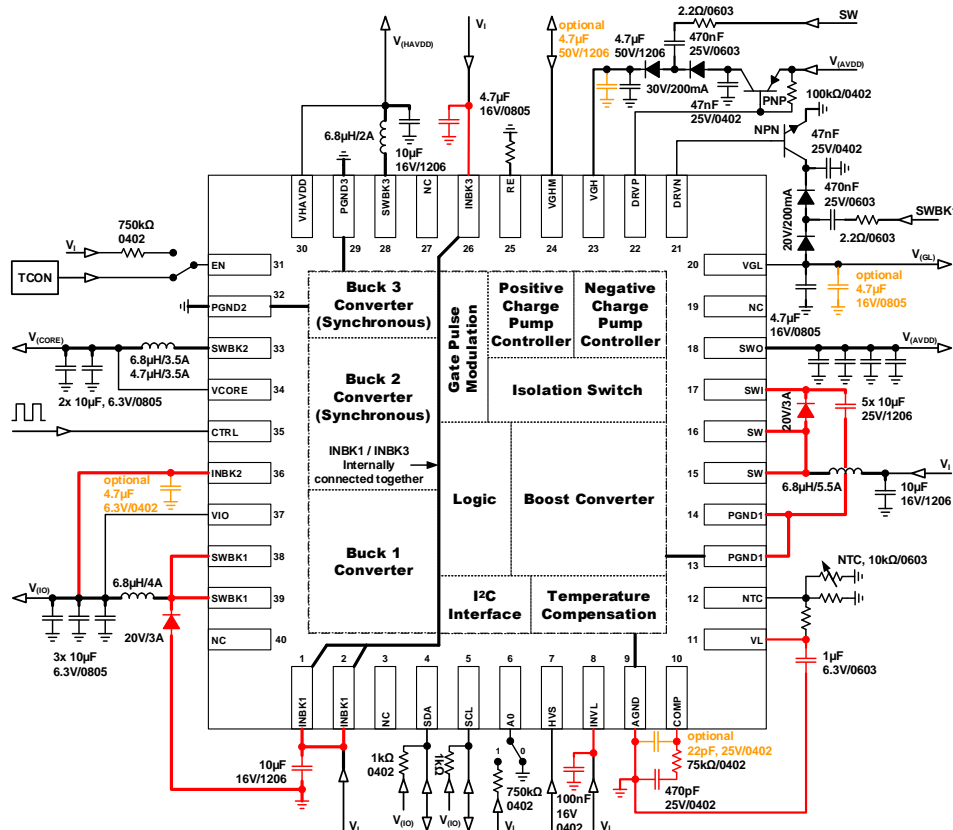
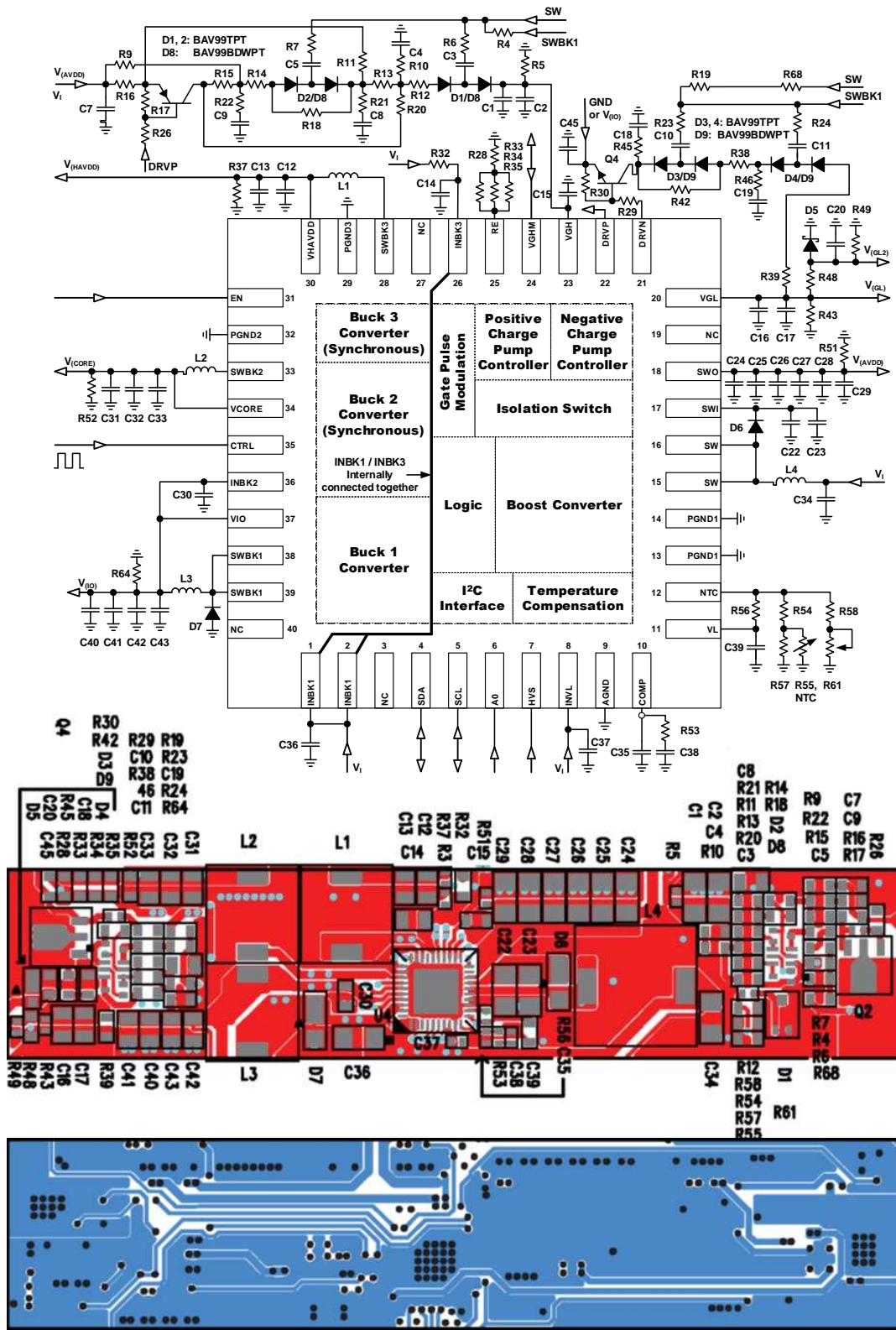

Figure 48. Example Layout

Layout Example (continued)



Options can be removed if not needed

Figure 49. Sample 2-layer Layout

11 Device and Documentation Support

11.1 Related Links

The table below lists quick access links. Categories include technical documents, support and community resources, tools and software, and quick access to sample or buy.

Table 8. Related Links

PARTS	PRODUCT FOLDER	SAMPLE & BUY	TECHNICAL DOCUMENTS	TOOLS & SOFTWARE	SUPPORT & COMMUNITY
TPS65177	Click here	Click here	Click here	Click here	Click here
TPS65177A	Click here	Click here	Click here	Click here	Click here

11.2 Third-Party Products Disclaimer

TI'S PUBLICATION OF INFORMATION REGARDING THIRD-PARTY PRODUCTS OR SERVICES DOES NOT CONSTITUTE AN ENDORSEMENT REGARDING THE SUITABILITY OF SUCH PRODUCTS OR SERVICES OR A WARRANTY, REPRESENTATION OR ENDORSEMENT OF SUCH PRODUCTS OR SERVICES, EITHER ALONE OR IN COMBINATION WITH ANY TI PRODUCT OR SERVICE.

11.3 Community Resources

The following links connect to TI community resources. Linked contents are provided "AS IS" by the respective contributors. They do not constitute TI specifications and do not necessarily reflect TI's views; see TI's [Terms of Use](#).

TI E2E™ Online Community *TI's Engineer-to-Engineer (E2E) Community*. Created to foster collaboration among engineers. At e2e.ti.com, you can ask questions, share knowledge, explore ideas and help solve problems with fellow engineers.

Design Support *TI's Design Support* Quickly find helpful E2E forums along with design support tools and contact information for technical support.

11.4 Trademarks

E2E is a trademark of Texas Instruments.
All other trademarks are the property of their respective owners.

11.5 Electrostatic Discharge Caution



These devices have limited built-in ESD protection. The leads should be shorted together or the device placed in conductive foam during storage or handling to prevent electrostatic damage to the MOS gates.

11.6 Glossary

[SLYZ022](#) — *TI Glossary*.

This glossary lists and explains terms, acronyms, and definitions.

12 Mechanical, Packaging, and Orderable Information

The following pages include mechanical, packaging, and orderable information. This information is the most current data available for the designated devices. This data is subject to change without notice and revision of this document. For browser-based versions of this data sheet, refer to the left-hand navigation.

PACKAGING INFORMATION

Orderable part number	Status (1)	Material type (2)	Package Pins	Package qty Carrier	RoHS (3)	Lead finish/ Ball material (4)	MSL rating/ Peak reflow (5)	Op temp (°C)	Part marking (6)
TPS65177ARHAR	Active	Production	VQFN (RHA) 40	2500 LARGE T&R	Yes	NIPDAU	Level-3-260C-168 HR	-40 to 150	TPS 65177A
TPS65177ARHAR.A	Active	Production	VQFN (RHA) 40	2500 LARGE T&R	Yes	NIPDAU	Level-3-260C-168 HR	-40 to 150	TPS 65177A
TPS65177RHAR	NRND	Production	VQFN (RHA) 40	2500 LARGE T&R	Yes	NIPDAU	Level-3-260C-168 HR	-40 to 85	TPS 65177
TPS65177RHAR.A	NRND	Production	VQFN (RHA) 40	2500 LARGE T&R	Yes	NIPDAU	Level-3-260C-168 HR	-40 to 85	TPS 65177

(1) **Status:** For more details on status, see our [product life cycle](#).

(2) **Material type:** When designated, preproduction parts are prototypes/experimental devices, and are not yet approved or released for full production. Testing and final process, including without limitation quality assurance, reliability performance testing, and/or process qualification, may not yet be complete, and this item is subject to further changes or possible discontinuation. If available for ordering, purchases will be subject to an additional waiver at checkout, and are intended for early internal evaluation purposes only. These items are sold without warranties of any kind.

(3) **RoHS values:** Yes, No, RoHS Exempt. See the [TI RoHS Statement](#) for additional information and value definition.

(4) **Lead finish/Ball material:** Parts may have multiple material finish options. Finish options are separated by a vertical ruled line. Lead finish/Ball material values may wrap to two lines if the finish value exceeds the maximum column width.

(5) **MSL rating/Peak reflow:** The moisture sensitivity level ratings and peak solder (reflow) temperatures. In the event that a part has multiple moisture sensitivity ratings, only the lowest level per JEDEC standards is shown. Refer to the shipping label for the actual reflow temperature that will be used to mount the part to the printed circuit board.

(6) **Part marking:** There may be an additional marking, which relates to the logo, the lot trace code information, or the environmental category of the part.

Multiple part markings will be inside parentheses. Only one part marking contained in parentheses and separated by a "-" will appear on a part. If a line is indented then it is a continuation of the previous line and the two combined represent the entire part marking for that device.

Important Information and Disclaimer: The information provided on this page represents TI's knowledge and belief as of the date that it is provided. TI bases its knowledge and belief on information provided by third parties, and makes no representation or warranty as to the accuracy of such information. Efforts are underway to better integrate information from third parties. TI has taken and continues to take reasonable steps to provide representative and accurate information but may not have conducted destructive testing or chemical analysis on incoming materials and chemicals. TI and TI suppliers consider certain information to be proprietary, and thus CAS numbers and other limited information may not be available for release.

In no event shall TI's liability arising out of such information exceed the total purchase price of the TI part(s) at issue in this document sold by TI to Customer on an annual basis.

TAPE AND REEL INFORMATION

QUADRANT ASSIGNMENTS FOR PIN 1 ORIENTATION IN TAPE

*All dimensions are nominal

Device	Package Type	Package Drawing	Pins	SPQ	Reel Diameter (mm)	Reel Width W1 (mm)	A0 (mm)	B0 (mm)	K0 (mm)	P1 (mm)	W (mm)	Pin1 Quadrant
TPS65177ARHAR	VQFN	RHA	40	2500	330.0	16.4	6.3	6.3	1.1	12.0	16.0	Q2
TPS65177RHAR	VQFN	RHA	40	2500	330.0	16.4	6.3	6.3	1.1	12.0	16.0	Q2

TAPE AND REEL BOX DIMENSIONS

*All dimensions are nominal

Device	Package Type	Package Drawing	Pins	SPQ	Length (mm)	Width (mm)	Height (mm)
TPS65177ARHAR	VQFN	RHA	40	2500	552.0	367.0	38.0
TPS65177RHAR	VQFN	RHA	40	2500	552.0	367.0	38.0

TUBE

*All dimensions are nominal

Device	Package Name	Package Type	Pins	SPQ	L (mm)	W (mm)	T (μm)	B (mm)
TPS65177ARHAR	RHA	VQFN	40	2500	381.5	7.92	2286	0
TPS65177ARHAR.A	RHA	VQFN	40	2500	381.5	7.92	2286	0
TPS65177RHAR	RHA	VQFN	40	2500	381.5	7.92	2286	0
TPS65177RHAR.A	RHA	VQFN	40	2500	381.5	7.92	2286	0

GENERIC PACKAGE VIEW

RHA 40

VQFN - 1 mm max height

6 x 6, 0.5 mm pitch

PLASTIC QUAD FLATPACK - NO LEAD

This image is a representation of the package family, actual package may vary.
Refer to the product data sheet for package details.



4225870/A

IMPORTANT NOTICE AND DISCLAIMER

TI PROVIDES TECHNICAL AND RELIABILITY DATA (INCLUDING DATA SHEETS), DESIGN RESOURCES (INCLUDING REFERENCE DESIGNS), APPLICATION OR OTHER DESIGN ADVICE, WEB TOOLS, SAFETY INFORMATION, AND OTHER RESOURCES "AS IS" AND WITH ALL FAULTS, AND DISCLAIMS ALL WARRANTIES, EXPRESS AND IMPLIED, INCLUDING WITHOUT LIMITATION ANY IMPLIED WARRANTIES OF MERCHANTABILITY, FITNESS FOR A PARTICULAR PURPOSE OR NON-INFRINGEMENT OF THIRD PARTY INTELLECTUAL PROPERTY RIGHTS.

These resources are intended for skilled developers designing with TI products. You are solely responsible for (1) selecting the appropriate TI products for your application, (2) designing, validating and testing your application, and (3) ensuring your application meets applicable standards, and any other safety, security, regulatory or other requirements.

These resources are subject to change without notice. TI grants you permission to use these resources only for development of an application that uses the TI products described in the resource. Other reproduction and display of these resources is prohibited. No license is granted to any other TI intellectual property right or to any third party intellectual property right. TI disclaims responsibility for, and you will fully indemnify TI and its representatives against, any claims, damages, costs, losses, and liabilities arising out of your use of these resources.

TI's products are provided subject to [TI's Terms of Sale](#) or other applicable terms available either on [ti.com](#) or provided in conjunction with such TI products. TI's provision of these resources does not expand or otherwise alter TI's applicable warranties or warranty disclaimers for TI products.

TI objects to and rejects any additional or different terms you may have proposed.

Mailing Address: Texas Instruments, Post Office Box 655303, Dallas, Texas 75265

Copyright © 2025, Texas Instruments Incorporated