



Tiva™ TM4C129ENC PDT Microcontroller

DATA SHEET

Copyright

Copyright © 2007-2014 Texas Instruments Incorporated. Tiva and TivaWare are trademarks of Texas Instruments Incorporated. ARM and Thumb are registered trademarks and Cortex is a trademark of ARM Limited. All other trademarks are the property of others.

PRODUCTION DATA information is current as of publication date. Products conform to specifications per the terms of Texas Instruments standard warranty. Production processing does not necessarily include testing of all parameters.

 Please be aware that an important notice concerning availability, standard warranty, and use in critical applications of Texas Instruments semiconductor products and disclaimers thereto appears at the end of this data sheet.

Texas Instruments Incorporated
108 Wild Basin, Suite 350
Austin, TX 78746

<http://www.ti.com/tm4c>

<http://www-k.ext.ti.com/sc/technical-support/product-information-centers.htm>



TEXAS
INSTRUMENTS



Cortex
Intelligent Processors by ARM

WARNING – EXPORT NOTICE: Recipient agrees to not knowingly export or re-export, directly or indirectly, any product or technical data (as defined by the U.S., EU, and other Export Administration Regulations) including software, or any controlled product restricted by other applicable national regulations, received from Disclosing party under this Agreement, or any direct product of such technology, to any destination to which such export or re-export is restricted or prohibited by U.S. or other applicable laws, without obtaining prior authorization from U.S. Department of Commerce and other competent Government authorities to the extent required by those laws.

According to our best knowledge of the state and end-use of this product or technology, and in compliance with the export control regulations of dual-use goods in force in the origin and exporting countries, this technology is classified as follows:

- US ECCN: EAR99
- EU ECCN: EAR99

And may require export or re-export license for shipping it in compliance with the applicable regulations of certain countries.

Table of Contents

Revision History	49
About This Document	52
Audience	52
About This Manual	52
Related Documents	52
Documentation Conventions	53
1 Architectural Overview	55
1.1 Tiva™ C Series Overview	55
1.2 TM4C129ENCPDT Microcontroller Overview	56
1.3 TM4C129ENCPDT Microcontroller Features	59
1.3.1 ARM Cortex-M4F Processor Core	59
1.3.2 On-Chip Memory	61
1.3.3 External Peripheral Interface	63
1.3.4 Cyclical Redundancy Check (CRC)	65
1.3.5 Advanced Encryption Standard (AES) Accelerator	65
1.3.6 Data Encryption Standard (DES) Accelerator	66
1.3.7 Secure Hash Algorithm / Message Digest Algorithm (SHA/MD5)	66
1.3.8 Serial Communications Peripherals	67
1.3.9 System Integration	73
1.3.10 Advanced Motion Control	79
1.3.11 Analog	82
1.3.12 JTAG and ARM Serial Wire Debug	83
1.3.13 Packaging and Temperature	84
1.4 TM4C129ENCPDT Microcontroller Hardware Details	84
1.5 Kits	84
1.6 Support Information	85
2 The Cortex-M4F Processor	86
2.1 Block Diagram	87
2.2 Overview	88
2.2.1 System-Level Interface	88
2.2.2 Integrated Configurable Debug	88
2.2.3 Trace Port Interface Unit (TPIU)	89
2.2.4 Cortex-M4F System Component Details	89
2.3 Programming Model	90
2.3.1 Processor Mode and Privilege Levels for Software Execution	90
2.3.2 Stacks	91
2.3.3 Register Map	91
2.3.4 Register Descriptions	93
2.3.5 Exceptions and Interrupts	109
2.3.6 Data Types	109
2.4 Memory Model	109
2.4.1 Memory Regions, Types and Attributes	112
2.4.2 Memory System Ordering of Memory Accesses	113
2.4.3 Behavior of Memory Accesses	113
2.4.4 Software Ordering of Memory Accesses	114

2.4.5	Bit-Banding	115
2.4.6	Data Storage	117
2.4.7	Synchronization Primitives	118
2.5	Exception Model	119
2.5.1	Exception States	120
2.5.2	Exception Types	120
2.5.3	Exception Handlers	125
2.5.4	Vector Table	125
2.5.5	Exception Priorities	126
2.5.6	Interrupt Priority Grouping	127
2.5.7	Exception Entry and Return	127
2.6	Fault Handling	130
2.6.1	Fault Types	131
2.6.2	Fault Escalation and Hard Faults	131
2.6.3	Fault Status Registers and Fault Address Registers	132
2.6.4	Lockup	132
2.7	Power Management	133
2.7.1	Entering Sleep Modes	133
2.7.2	Wake Up from Sleep Mode	133
2.8	Instruction Set Summary	134
3	Cortex-M4 Peripherals	141
3.1	Functional Description	141
3.1.1	System Timer (SysTick)	142
3.1.2	Nested Vectored Interrupt Controller (NVIC)	143
3.1.3	System Control Block (SCB)	144
3.1.4	Memory Protection Unit (MPU)	144
3.1.5	Floating-Point Unit (FPU)	149
3.2	Register Map	153
3.3	System Timer (SysTick) Register Descriptions	156
3.4	NVIC Register Descriptions	160
3.5	System Control Block (SCB) Register Descriptions	170
3.6	Memory Protection Unit (MPU) Register Descriptions	199
3.7	Floating-Point Unit (FPU) Register Descriptions	208
4	JTAG Interface	214
4.1	Block Diagram	215
4.2	Signal Description	215
4.3	Functional Description	216
4.3.1	JTAG Interface Pins	216
4.3.2	JTAG TAP Controller	218
4.3.3	Shift Registers	219
4.3.4	Operational Considerations	219
4.4	Initialization and Configuration	222
4.5	Register Descriptions	222
4.5.1	Instruction Register (IR)	223
4.5.2	Data Registers	224
5	System Control	227
5.1	Signal Description	227
5.2	Functional Description	227

5.2.1	Device Identification	227
5.2.2	Reset Control	228
5.2.3	Non-Maskable Interrupt	235
5.2.4	Power Control	236
5.2.5	Clock Control	237
5.2.6	System Control	246
5.3	Initialization and Configuration	253
5.4	Register Map	254
5.5	System Control Register Descriptions (System Control Offset)	261
5.6	Cryptographic System Control Register Description (CCM Offset)	529
6	Processor Support and Exception Module	531
6.1	Functional Description	531
6.2	Register Map	531
6.3	Register Descriptions	531
7	Hibernation Module	539
7.1	Block Diagram	541
7.2	Signal Description	541
7.3	Functional Description	542
7.3.1	Register Access Timing	543
7.3.2	Hibernation Clock Source	543
7.3.3	System Implementation	546
7.3.4	Battery Management	547
7.3.5	Real-Time Clock	547
7.3.6	Tamper	550
7.3.7	Battery-Backed Memory	553
7.3.8	Power Control Using \overline{HIB}	553
7.3.9	Power Control Using VDD3ON Mode	554
7.3.10	Initiating Hibernate	554
7.3.11	Waking from Hibernate	554
7.3.12	Arbitrary Power Removal	555
7.3.13	Interrupts and Status	556
7.4	Initialization and Configuration	556
7.4.1	Initialization	556
7.4.2	RTC Match Functionality (No Hibernation)	557
7.4.3	RTC Match/Wake-Up from Hibernation	557
7.4.4	External Wake-Up from Hibernation	558
7.4.5	RTC or External Wake-Up from Hibernation	559
7.4.6	Tamper Initialization	559
7.5	Register Map	559
7.6	Register Descriptions	561
8	Internal Memory	608
8.1	Block Diagram	608
8.2	Functional Description	610
8.2.1	SRAM	610
8.2.2	ROM	610
8.2.3	Flash Memory	612
8.2.4	EEPROM	623
8.2.5	Bus Matrix Memory Accesses	629

8.3	Register Map	629
8.4	Internal Memory Register Descriptions (Internal Memory Control Offset)	632
8.5	EEPROM Register Descriptions (EEPROM Offset)	658
8.6	Memory Register Descriptions (System Control Offset)	675
9	Micro Direct Memory Access (μDMA)	686
9.1	Block Diagram	687
9.2	Functional Description	687
9.2.1	Channel Assignments	688
9.2.2	Priority	689
9.2.3	Arbitration Size	690
9.2.4	Request Types	690
9.2.5	Channel Configuration	691
9.2.6	Transfer Modes	693
9.2.7	Transfer Size and Increment	701
9.2.8	Peripheral Interface	701
9.2.9	Software Request	702
9.2.10	Interrupts and Errors	702
9.3	Initialization and Configuration	702
9.3.1	Module Initialization	702
9.3.2	Configuring a Memory-to-Memory Transfer	703
9.3.3	Configuring a Peripheral for Simple Transmit	704
9.3.4	Configuring a Peripheral for Ping-Pong Receive	706
9.3.5	Configuring Channel Assignments	709
9.4	Register Map	709
9.5	μ DMA Channel Control Structure	710
9.6	μ DMA Register Descriptions	717
10	General-Purpose Input/Outputs (GPIOs)	750
10.1	Signal Description	751
10.2	Pad Capabilities	754
10.3	Functional Description	755
10.3.1	Data Control	756
10.3.2	Interrupt Control	758
10.3.3	Mode Control	759
10.3.4	Commit Control	760
10.3.5	Pad Control	760
10.3.6	Identification	761
10.4	Initialization and Configuration	761
10.5	Register Map	763
10.6	Register Descriptions	766
11	External Peripheral Interface (EPI)	823
11.1	EPI Block Diagram	824
11.2	Signal Description	825
11.3	Functional Description	826
11.3.1	Master Access to EPI	827
11.3.2	Non-Blocking Reads	827
11.3.3	DMA Operation	828
11.4	Initialization and Configuration	829
11.4.1	EPI Interface Options	830

11.4.2	SDRAM Mode	830
11.4.3	Host Bus Mode	834
11.4.4	General-Purpose Mode	855
11.5	Register Map	862
11.6	Register Descriptions	864
12	Cyclical Redundancy Check (CRC)	954
12.1	Functional Description	954
12.1.1	CRC Support	954
12.2	Initialization and Configuration	956
12.2.1	CRC Initialization and Configuration	956
12.3	Register Map	957
12.4	CRC Module Register Descriptions	957
13	Advance Encryption Standard Accelerator (AES)	963
13.1	AES Overview	963
13.2	AES Functional Description	963
13.2.1	AES Block Diagram	964
13.2.2	AES Algorithm	967
13.2.3	AES Operating Modes	968
13.2.4	AES Software Reset	976
13.2.5	Power Management	976
13.2.6	Hardware Requests	976
13.3	AES Performance Information	977
13.4	AES Module Programming Guide	979
13.4.1	AES Low - Level Programming Models	979
13.5	Register Map	984
13.6	AES Register Descriptions	986
13.7	AES μ DMA Interrupt Register Descriptions (CCM Offset)	1008
14	Data Encryption Standard Accelerator (DES)	1015
14.1	DES Functional Description	1015
14.2	DES Block Diagram	1016
14.2.1	μ DMA Control	1016
14.2.2	Interrupt Control	1017
14.2.3	Register Interface	1017
14.2.4	DES Engine	1017
14.3	Software Reset	1018
14.4	DES Supported Modes of Operation	1018
14.4.1	ECB Feedback Mode	1018
14.5	DES Module Programming Guide -Low Level Programming Models	1020
14.5.1	Surrounding Modules Global Initialization	1020
14.5.2	Operational Modes Configuration	1021
14.5.3	DES Events Servicing	1023
14.6	Register Map	1024
14.7	DES Register Description	1025
14.8	DES μ DMA Interrupt Register Descriptions (CCM Offset)	1039
15	SHA/MD5 Accelerator	1044
15.1	SHA/MD5 Functional Description	1044
15.1.1	SHA/MD5 Block Diagram	1044

15.1.2	Power Management	1046
15.1.3	Reset Management	1046
15.1.4	μDMA and Interrupt Requests	1046
15.1.5	Operation Description	1047
15.1.6	SHA/MD5 Performance Information	1053
15.1.7	SHA/MD5 Programming Guide	1054
15.2	SHA/MD5 Register Map	1058
15.3	SHA/MD5 Register Descriptions	1060
15.4	SHA/MD5 μDMA Control Register Descriptions (Encryption Control Offset)	1074
16	General-Purpose Timers	1079
16.1	Block Diagram	1080
16.2	Signal Description	1081
16.3	Functional Description	1082
16.3.1	GPTM Reset Conditions	1083
16.3.2	Timer Clock Source	1083
16.3.3	Timer Modes	1083
16.3.4	Wait-for-Trigger Mode	1092
16.3.5	Synchronizing GP Timer Blocks	1093
16.3.6	DMA Operation	1094
16.3.7	ADC Operation	1094
16.3.8	Accessing Concatenated 16/32-Bit GPTM Register Values	1094
16.4	Initialization and Configuration	1095
16.4.1	One-Shot/Periodic Timer Mode	1095
16.4.2	Real-Time Clock (RTC) Mode	1096
16.4.3	Input Edge-Count Mode	1096
16.4.4	Input Edge Time Mode	1097
16.4.5	PWM Mode	1097
16.5	Register Map	1098
16.6	Register Descriptions	1099
17	Watchdog Timers	1152
17.1	Block Diagram	1153
17.2	Functional Description	1153
17.2.1	Register Access Timing	1154
17.3	Initialization and Configuration	1154
17.4	Register Map	1154
17.5	Register Descriptions	1155
18	Analog-to-Digital Converter (ADC)	1177
18.1	Block Diagram	1178
18.2	Signal Description	1179
18.3	Functional Description	1180
18.3.1	Sample Sequencers	1180
18.3.2	Module Control	1181
18.3.3	Hardware Sample Averaging Circuit	1186
18.3.4	Analog-to-Digital Converter	1187
18.3.5	Differential Sampling	1189
18.3.6	Internal Temperature Sensor	1191
18.3.7	Digital Comparator Unit	1192
18.4	Initialization and Configuration	1196

18.4.1	Module Initialization	1196
18.4.2	Sample Sequencer Configuration	1197
18.5	Register Map	1197
18.6	Register Descriptions	1200
19	Universal Asynchronous Receivers/Transmitters (UARTs)	1285
19.1	Block Diagram	1286
19.2	Signal Description	1286
19.3	Functional Description	1288
19.3.1	Transmit/Receive Logic	1288
19.3.2	Baud-Rate Generation	1289
19.3.3	Data Transmission	1290
19.3.4	Serial IR (SIR)	1290
19.3.5	ISO 7816 Support	1291
19.3.6	Modem Handshake Support	1292
19.3.7	9-Bit UART Mode	1293
19.3.8	FIFO Operation	1293
19.3.9	Interrupts	1294
19.3.10	Loopback Operation	1295
19.3.11	DMA Operation	1295
19.4	Initialization and Configuration	1296
19.5	Register Map	1297
19.6	Register Descriptions	1298
20	Quad Synchronous Serial Interface (QSSI)	1350
20.1	Block Diagram	1350
20.2	Signal Description	1351
20.3	Functional Description	1352
20.3.1	Bit Rate Generation	1353
20.3.2	FIFO Operation	1353
20.3.3	Advanced, Bi- and Quad- SSI Function	1354
20.3.4	SSInFSS Function	1355
20.3.5	High Speed Clock Operation	1356
20.3.6	Interrupts	1356
20.3.7	Frame Formats	1357
20.3.8	DMA Operation	1364
20.4	Initialization and Configuration	1364
20.4.1	Enhanced Mode Configuration	1366
20.5	Register Map	1367
20.6	Register Descriptions	1368
21	Inter-Integrated Circuit (I²C) Interface	1399
21.1	Block Diagram	1400
21.2	Signal Description	1401
21.3	Functional Description	1402
21.3.1	I ² C Bus Functional Overview	1402
21.3.2	Available Speed Modes	1408
21.3.3	Interrupts	1410
21.3.4	Loopback Operation	1411
21.3.5	FIFO and μ DMA Operation	1411
21.3.6	Command Sequence Flow Charts	1413

21.4	Initialization and Configuration	1421
21.4.1	Configure the I ² C Module to Transmit a Single Byte as a Master	1421
21.4.2	Configure the I ² C Master to High Speed Mode	1422
21.5	Register Map	1423
21.6	Register Descriptions (I ² C Master)	1425
21.7	Register Descriptions (I ² C Slave)	1454
21.8	Register Descriptions (I ² C Status and Control)	1471
22	Controller Area Network (CAN) Module	1480
22.1	Block Diagram	1481
22.2	Signal Description	1481
22.3	Functional Description	1482
22.3.1	Initialization	1483
22.3.2	Operation	1483
22.3.3	Transmitting Message Objects	1484
22.3.4	Configuring a Transmit Message Object	1485
22.3.5	Updating a Transmit Message Object	1486
22.3.6	Accepting Received Message Objects	1486
22.3.7	Receiving a Data Frame	1487
22.3.8	Receiving a Remote Frame	1487
22.3.9	Receive/Transmit Priority	1487
22.3.10	Configuring a Receive Message Object	1488
22.3.11	Handling of Received Message Objects	1489
22.3.12	Handling of Interrupts	1491
22.3.13	Test Mode	1492
22.3.14	Bit Timing Configuration Error Considerations	1494
22.3.15	Bit Time and Bit Rate	1494
22.3.16	Calculating the Bit Timing Parameters	1496
22.4	Register Map	1499
22.5	CAN Register Descriptions	1500
23	Ethernet Controller	1531
23.1	Block Diagram	1532
23.2	Signal Description	1532
23.3	Functional Description	1533
23.3.1	Ethernet Clock Control	1533
23.3.2	DMA Controller	1534
23.3.3	TX/RX Controller	1558
23.3.4	MAC Operation	1562
23.3.5	IEEE 1588 and Advanced Timestamp Function	1564
23.3.6	Frame Filtering	1573
23.3.7	Source Address, VLAN, and CRC Insertion, Replacement or Deletion	1574
23.3.8	Checksum Offload Engine	1576
23.3.9	MAC Management Counters	1577
23.3.10	Power Management Module	1578
23.3.11	Serial Management Interface	1581
23.3.12	Interrupt Configuration	1581
23.4	Ethernet PHY	1581
23.4.1	Integrated PHY Block Diagram	1581
23.4.2	Functional Description	1582

23.4.3	Interface Configuration	1587
23.5	Initialization and Configuration	1588
23.5.1	Ethernet PHY Initialization	1589
23.6	Register Map	1591
23.7	Ethernet MAC Register Descriptions	1594
23.8	Ethernet PHY Register Descriptions	1713
24	Universal Serial Bus (USB) Controller	1768
24.1	Block Diagram	1769
24.2	Signal Description	1769
24.3	Register Map	1770
25	Analog Comparators	1777
25.1	Block Diagram	1778
25.2	Signal Description	1778
25.3	Functional Description	1779
25.3.1	Internal Reference Programming	1780
25.4	Initialization and Configuration	1782
25.5	Register Map	1783
25.6	Register Descriptions	1783
26	Pulse Width Modulator (PWM)	1793
26.1	Block Diagram	1794
26.2	Signal Description	1796
26.3	Functional Description	1796
26.3.1	Clock Configuration	1796
26.3.2	PWM Timer	1796
26.3.3	PWM Comparators	1797
26.3.4	PWM Signal Generator	1798
26.3.5	Dead-Band Generator	1799
26.3.6	Interrupt/ADC-Trigger Selector	1799
26.3.7	Synchronization Methods	1800
26.3.8	Fault Conditions	1801
26.3.9	Output Control Block	1802
26.4	Initialization and Configuration	1802
26.5	Register Map	1803
26.6	Register Descriptions	1806
27	Quadrature Encoder Interface (QEI)	1872
27.1	Block Diagram	1872
27.2	Signal Description	1874
27.3	Functional Description	1874
27.4	Initialization and Configuration	1877
27.5	Register Map	1877
27.6	Register Descriptions	1878
28	Pin Diagram	1895
29	Signal Tables	1896
29.1	Signals by Pin Number	1897
29.2	Signals by Signal Name	1909
29.3	Signals by Function, Except for GPIO	1921
29.4	GPIO Pins and Alternate Functions	1932

29.5	Possible Pin Assignments for Alternate Functions	1935
29.6	Connections for Unused Signals	1940
30	Electrical Characteristics	1942
30.1	Maximum Ratings	1942
30.2	Operating Characteristics	1943
30.3	Recommended Operating Conditions	1944
30.3.1	DC Operating Conditions	1944
30.3.2	Recommended GPIO Operating Characteristics	1944
30.4	Load Conditions	1947
30.5	JTAG and Boundary Scan	1948
30.6	Power and Brown-Out	1950
30.6.1	V _{DDA} Levels	1950
30.6.2	V _{DD} Levels	1951
30.6.3	V _{DDC} Levels	1952
30.6.4	Response	1953
30.7	Reset	1955
30.8	On-Chip Low Drop-Out (LDO) Regulator	1958
30.9	Clocks	1959
30.9.1	PLL Specifications	1959
30.9.2	PIOSC Specifications	1961
30.9.3	Low-Frequency Internal Oscillator Specifications	1961
30.9.4	Hibernation Clock Source Specifications	1961
30.9.5	Main Oscillator Specifications	1962
30.9.6	System Clock Specification with ADC Operation	1966
30.9.7	System Clock Specification with USB Operation	1966
30.10	Sleep Modes	1967
30.11	Hibernation Module	1969
30.12	Flash Memory	1971
30.13	EEPROM	1972
30.14	Input/Output Pin Characteristics	1973
30.14.1	Types of I/O Pins and ESD Protection	1975
30.15	External Peripheral Interface (EPI)	1977
30.16	Analog-to-Digital Converter (ADC)	1985
30.17	Synchronous Serial Interface (SSI)	1991
30.18	Inter-Integrated Circuit (I ² C) Interface	1994
30.19	Ethernet Controller	1995
30.19.1	DC Characteristics	1995
30.19.2	Clock Characteristics	1995
30.19.3	AC Characteristics	1996
30.20	Universal Serial Bus (USB) Controller	1999
30.21	Analog Comparator	2001
30.22	Pulse-Width Modulator (PWM)	2003
30.23	Current Consumption	2004
A	Package Information	2009
A.1	Orderable Devices	2009
A.2	Device Nomenclature	2009
A.3	Device Markings	2009
A.4	Packaging Diagram	2011

List of Figures

Figure 1-1.	Tiva™ TM4C129ENCPDT Microcontroller High-Level Block Diagram	58
Figure 2-1.	CPU Block Diagram	88
Figure 2-2.	TPIU Block Diagram	89
Figure 2-3.	Cortex-M4F Register Set	92
Figure 2-4.	Bit-Band Mapping	117
Figure 2-5.	Data Storage	118
Figure 2-6.	Vector Table	126
Figure 2-7.	Exception Stack Frame	129
Figure 3-1.	SRD Use Example	147
Figure 3-2.	FPU Register Bank	150
Figure 4-1.	JTAG Module Block Diagram	215
Figure 4-2.	Test Access Port State Machine	219
Figure 4-3.	IDCODE Register Format	225
Figure 4-4.	BYPASS Register Format	225
Figure 4-5.	Boundary Scan Register Format	225
Figure 5-1.	Basic $\overline{\text{RST}}$ Configuration	231
Figure 5-2.	External Circuitry to Extend Power-On Reset	231
Figure 5-3.	Reset Circuit Controlled by Switch	231
Figure 5-4.	Power Architecture	236
Figure 5-5.	Main Clock Tree	240
Figure 5-6.	Module Clock Selection	249
Figure 7-1.	Hibernation Module Block Diagram	541
Figure 7-2.	Using a Crystal as the Hibernation Clock Source with a Single Battery Source	545
Figure 7-3.	Using a Dedicated Oscillator as the Hibernation Clock Source with VDD3ON Mode	545
Figure 7-4.	Using a Regulator for Both V_{DD} and V_{BAT}	546
Figure 7-5.	Counter Behavior with a TRIM Value of 0x8002	550
Figure 7-6.	Counter Behavior with a TRIM Value of 0x7FFC	550
Figure 7-7.	Tamper Block Diagram	550
Figure 7-8.	Tamper Pad with Glitch Filtering	551
Figure 8-1.	Internal Memory Block Diagram	609
Figure 8-2.	Flash Memory Configuration	613
Figure 8-3.	Single 256-Bit Prefetch Buffer Set	614
Figure 8-4.	Four 256-Bit Prefetch Buffer Configuration	614
Figure 8-5.	Single Cycle Access, 0 Wait States	615
Figure 8-6.	Prefetch Fills from Flash	616
Figure 8-7.	Mirror Mode Function	617
Figure 9-1.	μ DMA Block Diagram	687
Figure 9-2.	Example of Ping-Pong μ DMA Transaction	694
Figure 9-3.	Memory Scatter-Gather, Setup and Configuration	696
Figure 9-4.	Memory Scatter-Gather, μ DMA Copy Sequence	697
Figure 9-5.	Peripheral Scatter-Gather, Setup and Configuration	699
Figure 9-6.	Peripheral Scatter-Gather, μ DMA Copy Sequence	700
Figure 10-1.	Digital I/O Pads	755
Figure 10-2.	Analog/Digital I/O Pads	756
Figure 10-3.	GPIO DATA Write Example	757

Figure 10-4.	GPIODATA Read Example	757
Figure 11-1.	EPI Block Diagram	825
Figure 11-2.	SDRAM Non-Blocking Read Cycle	832
Figure 11-3.	SDRAM Normal Read Cycle	833
Figure 11-4.	SDRAM Write Cycle	834
Figure 11-5.	iRDY Access Stalls, IRDYDLY==01, 10, 11	844
Figure 11-6.	iRDY Signal Connection	844
Figure 11-7.	PSRAM Burst Read	847
Figure 11-8.	PSRAM Burst Write	847
Figure 11-9.	Read Delay During Refresh Event	848
Figure 11-10.	Write Delay During Refresh Event	849
Figure 11-11.	Example Schematic for Muxed Host-Bus 16 Mode	850
Figure 11-12.	Host-Bus Read Cycle, MODE = 0x1, WRHIGH = 0, RDHIGH = 0	853
Figure 11-13.	Host-Bus Write Cycle, MODE = 0x1, WRHIGH = 0, RDHIGH = 0	853
Figure 11-14.	Host-Bus Write Cycle with Multiplexed Address and Data, MODE = 0x0, WRHIGH = 0, RDHIGH = 0	854
Figure 11-15.	Host-Bus Write Cycle with Multiplexed Address and Data and ALE with Dual or Quad CSn	854
Figure 11-16.	Continuous Read Mode Accesses	854
Figure 11-17.	Write Followed by Read to External FIFO	855
Figure 11-18.	Two-Entry FIFO	855
Figure 11-19.	Single-Cycle Single Write Access, FRM50=0, FRMCNT=0, WR2CYC=0	858
Figure 11-20.	Two-Cycle Read, Write Accesses, FRM50=0, FRMCNT=0, WR2CYC=1	859
Figure 11-21.	Read Accesses, FRM50=0, FRMCNT=0	859
Figure 11-22.	FRAME Signal Operation, FRM50=0 and FRMCNT=0	860
Figure 11-23.	FRAME Signal Operation, FRM50=0 and FRMCNT=1	860
Figure 11-24.	FRAME Signal Operation, FRM50=0 and FRMCNT=2	860
Figure 11-25.	FRAME Signal Operation, FRM50=1 and FRMCNT=0	860
Figure 11-26.	FRAME Signal Operation, FRM50=1 and FRMCNT=1	861
Figure 11-27.	FRAME Signal Operation, FRM50=1 and FRMCNT=2	861
Figure 11-28.	EPI Clock Operation, CLKGATE=1, WR2CYC=0	861
Figure 11-29.	EPI Clock Operation, CLKGATE=1, WR2CYC=1	862
Figure 13-1.	AES Block Diagram	964
Figure 13-2.	AES - ECB Feedback Mode	968
Figure 13-3.	AES - CBC Feedback Mode	969
Figure 13-4.	AES Encryption With CTR/ICM Mode	969
Figure 13-5.	AES - CFB Feedback Mode	970
Figure 13-6.	AES - F8 Mode	971
Figure 13-7.	AES - XTS Operation	971
Figure 13-8.	AES - F9 Operation	972
Figure 13-9.	AES - CBC-MAC Authentication Mode	973
Figure 13-10.	AES - GCM Operation	974
Figure 13-11.	AES - CCM Operation	975
Figure 13-12.	AES Polling Mode	982
Figure 13-13.	AES Interrupt Service	984
Figure 14-1.	DES Block Diagram	1016
Figure 14-2.	DES - ECB Feedback Mode	1019
Figure 14-3.	DES3DES - CBC Feedback Mode	1019

Figure 14-4.	DES3DES-CFB Feedback Mode	1020
Figure 14-5.	DES Polling Mode	1022
Figure 14-6.	DES Interrupt Service	1023
Figure 14-7.	DES Context Input Event Service	1024
Figure 15-1.	SHA/MD5 Module Block Diagram	1045
Figure 15-2.	SHA/MD5 Polling Mode	1056
Figure 15-3.	SHA/MD5 Interrupt Subroutine	1058
Figure 16-1.	GPTM Module Block Diagram	1080
Figure 16-2.	Input Edge-Count Mode Example, Counting Down	1088
Figure 16-3.	16-Bit Input Edge-Time Mode Example	1089
Figure 16-4.	16-Bit PWM Mode Example	1091
Figure 16-5.	CCP Output, GPTMTnMATCHR > GPTMTnILR	1091
Figure 16-6.	CCP Output, GPTMTnMATCHR = GPTMTnILR	1092
Figure 16-7.	CCP Output, GPTMTnILR > GPTMTnMATCHR	1092
Figure 16-8.	Timer Daisy Chain	1093
Figure 17-1.	WDT Module Block Diagram	1153
Figure 18-1.	Implementation of Two ADC Blocks	1178
Figure 18-2.	ADC Module Block Diagram	1179
Figure 18-3.	ADC Sample Phases	1184
Figure 18-4.	Doubling the ADC Sample Rate	1184
Figure 18-5.	Skewed Sampling	1185
Figure 18-6.	Sample Averaging Example	1187
Figure 18-7.	ADC Input Equivalency	1188
Figure 18-8.	ADC Voltage Reference	1188
Figure 18-9.	ADC Conversion Result	1189
Figure 18-10.	Differential Voltage Representation	1191
Figure 18-11.	Internal Temperature Sensor Characteristic	1192
Figure 18-12.	Low-Band Operation (CIC=0x0 and/or CTC=0x0)	1194
Figure 18-13.	Mid-Band Operation (CIC=0x1 and/or CTC=0x1)	1195
Figure 18-14.	High-Band Operation (CIC=0x3 and/or CTC=0x3)	1196
Figure 19-1.	UART Module Block Diagram	1286
Figure 19-2.	UART Character Frame	1289
Figure 19-3.	IrDA Data Modulation	1291
Figure 20-1.	QSSI Module with Advanced, Bi-SSI and Quad-SSI Support	1351
Figure 20-2.	TI Synchronous Serial Frame Format (Single Transfer)	1358
Figure 20-3.	TI Synchronous Serial Frame Format (Continuous Transfer)	1359
Figure 20-4.	Freescal SPI Format (Single Transfer) with SPO=0 and SPH=0	1360
Figure 20-5.	Freescal SPI Format (Continuous Transfer) with SPO=0 and SPH=0	1360
Figure 20-6.	Freescal SPI Frame Format with SPO=0 and SPH=1	1361
Figure 20-7.	Freescal SPI Frame Format (Single Transfer) with SPO=1 and SPH=0	1362
Figure 20-8.	Freescal SPI Frame Format (Continuous Transfer) with SPO=1 and SPH=0	1362
Figure 20-9.	Freescal SPI Frame Format with SPO=1 and SPH=1	1363
Figure 21-1.	I ² C Block Diagram	1400
Figure 21-2.	I ² C Bus Configuration	1402
Figure 21-3.	START and STOP Conditions	1403
Figure 21-4.	Complete Data Transfer with a 7-Bit Address	1403
Figure 21-5.	R/S Bit in First Byte	1404
Figure 21-6.	Data Validity During Bit Transfer on the I ² C Bus	1404

Figure 21-7.	High-Speed Data Format	1410
Figure 21-8.	Master Single TRANSMIT	1414
Figure 21-9.	Master Single RECEIVE	1415
Figure 21-10.	Master TRANSMIT of Multiple Data Bytes	1416
Figure 21-11.	Master RECEIVE of Multiple Data Bytes	1417
Figure 21-12.	Master RECEIVE with Repeated START after Master TRANSMIT	1418
Figure 21-13.	Master TRANSMIT with Repeated START after Master RECEIVE	1419
Figure 21-14.	Standard High Speed Mode Master Transmit	1420
Figure 21-15.	Slave Command Sequence	1421
Figure 22-1.	CAN Controller Block Diagram	1481
Figure 22-2.	CAN Data/Remote Frame	1482
Figure 22-3.	Message Objects in a FIFO Buffer	1491
Figure 22-4.	CAN Bit Time	1495
Figure 23-1.	Ethernet MAC with Integrated PHY Interface	1532
Figure 23-2.	Ethernet MAC and PHY Clock Structure	1534
Figure 23-3.	Enhanced Transmit Descriptor Structure	1538
Figure 23-4.	Enhanced Receive Descriptor Structure	1543
Figure 23-5.	TX DMA Default Operation Using Descriptors	1550
Figure 23-6.	TX DMA OSF Mode Operation Using Descriptors	1552
Figure 23-7.	RX DMA Operation Flow	1555
Figure 23-8.	Networked Time Synchronization	1565
Figure 23-9.	System Time Update Using Fine Correction Method	1567
Figure 23-10.	Propagation Delay Calculation in Clocks Supporting Peer-to-Peer Path Correction	1570
Figure 23-11.	Wake-Up Frame Filter Register Bank	1578
Figure 23-12.	Integrated PHY Diagram	1582
Figure 23-13.	Interface to Ethernet Jack	1588
Figure 24-1.	USB Module Block Diagram	1769
Figure 25-1.	Analog Comparator Module Block Diagram	1778
Figure 25-2.	Structure of Comparator Unit	1779
Figure 25-3.	Comparator Internal Reference Structure	1780
Figure 26-1.	PWM Module Diagram	1795
Figure 26-2.	PWM Generator Block Diagram	1795
Figure 26-3.	PWM Count-Down Mode	1798
Figure 26-4.	PWM Count-Up/Down Mode	1798
Figure 26-5.	PWM Generation Example In Count-Up/Down Mode	1799
Figure 26-6.	PWM Dead-Band Generator	1799
Figure 27-1.	QEI Block Diagram	1873
Figure 27-2.	QEI Input Signal Logic	1874
Figure 27-3.	Quadrature Encoder and Velocity Predivider Operation	1876
Figure 28-1.	128-Pin TQFP Package Pin Diagram	1895
Figure 30-1.	Load Conditions	1947
Figure 30-2.	JTAG Test Clock Input Timing	1949
Figure 30-3.	JTAG Test Access Port (TAP) Timing	1949
Figure 30-4.	Power and Brown-Out Assertions vs V_{DDA} Levels	1951
Figure 30-5.	Power and Brown-Out Assertions vs V_{DD} Levels	1952
Figure 30-6.	POK Assertion vs V_{DDC}	1953
Figure 30-7.	POR-BOR V_{DD} Glitch Response	1953

Figure 30-8.	POR-BOR V_{DD} Droop Response	1954
Figure 30-9.	Digital Power-On Reset Timing	1955
Figure 30-10.	Brown-Out Reset Timing	1956
Figure 30-11.	External Reset Timing (\overline{RST})	1956
Figure 30-12.	Software Reset Timing	1956
Figure 30-13.	Watchdog Reset Timing	1956
Figure 30-14.	MOSC Failure Reset Timing	1957
Figure 30-15.	Hibernation Module Timing	1970
Figure 30-16.	ESD Protection	1975
Figure 30-17.	ESD Protection for Non-Power Pins (Except \overline{WAKE} Signal)	1976
Figure 30-18.	SDRAM Initialization and Load Mode Register Timing	1978
Figure 30-19.	SDRAM Read Timing	1978
Figure 30-20.	SDRAM Write Timing	1979
Figure 30-21.	Host-Bus 8/16 Asynchronous Mode Read Timing	1980
Figure 30-22.	Host-Bus 8/16 Asynchronous Mode Write Timing	1980
Figure 30-23.	Host-Bus 8/16 Mode Asynchronous Muxed Read Timing	1981
Figure 30-24.	Host-Bus 8/16 Mode Asynchronous Muxed Write Timing	1981
Figure 30-25.	General-Purpose Mode Read and Write Timing	1982
Figure 30-26.	PSRAM Single Burst Read	1983
Figure 30-27.	PSRAM Single Burst Write	1984
Figure 30-28.	ADC External Reference Filtering	1990
Figure 30-29.	ADC Input Equivalency	1990
Figure 30-30.	SSI Timing for TI Frame Format (FRF=01), Single Transfer Timing Measurement	1992
Figure 30-31.	Master Mode SSI Timing for SPI Frame Format (FRF=00), with SPH=1	1992
Figure 30-32.	Slave Mode SSI Timing for SPI Frame Format (FRF=00), with SPH=1	1993
Figure 30-33.	I ² C Timing	1994
Figure 30-34.	MOSC Crystal Characteristics for Ethernet	1995
Figure 30-35.	Single-Ended MOSC Characteristics for Ethernet	1996
Figure 30-36.	Reset Timing	1996
Figure 30-37.	100 Base-TX Transmit Timing	1997
Figure 30-38.	10Base-TX Normal Link Pulse Timing	1997
Figure 30-39.	Auto-Negotiation Fast Link Pulse Timing	1998
Figure 30-40.	100Base-TX Signal Detect Timing	1998
Figure 30-41.	ULPI Interface Timing Diagram	2000
Figure A-1.	Key to Part Numbers	2009
Figure A-2.	TM4C129ENCPDT 128-Pin TQFP Package Diagram	2011

List of Tables

Table 1.	Revision History	49
Table 2.	Documentation Conventions	53
Table 1-1.	TM4C129ENCPDT Microcontroller Features	56
Table 2-1.	Summary of Processor Mode, Privilege Level, and Stack Use	91
Table 2-2.	Processor Register Map	92
Table 2-3.	PSR Register Combinations	98
Table 2-4.	Memory Map	109
Table 2-5.	Memory Access Behavior	113
Table 2-6.	SRAM Memory Bit-Banding Regions	115
Table 2-7.	Peripheral Memory Bit-Banding Regions	115
Table 2-8.	Exception Types	121
Table 2-9.	Interrupts	122
Table 2-10.	Exception Return Behavior	130
Table 2-11.	Faults	131
Table 2-12.	Fault Status and Fault Address Registers	132
Table 2-13.	Cortex-M4F Instruction Summary	134
Table 3-1.	Core Peripheral Register Regions	141
Table 3-2.	Memory Attributes Summary	145
Table 3-3.	TEX, S, C, and B Bit Field Encoding	147
Table 3-4.	Cache Policy for Memory Attribute Encoding	148
Table 3-5.	AP Bit Field Encoding	148
Table 3-6.	Memory Region Attributes for Tiva™ C Series Microcontrollers	149
Table 3-7.	QNaN and SNaN Handling	152
Table 3-8.	Peripherals Register Map	153
Table 3-9.	Interrupt Priority Levels	178
Table 3-10.	Example SIZE Field Values	206
Table 4-1.	JTAG_SWD_SWO Signals (128TQFP)	215
Table 4-2.	JTAG Port Pins State after Power-On Reset or $\overline{\text{RST}}$ assertion	217
Table 4-3.	JTAG Instruction Register Commands	223
Table 5-1.	System Control & Clocks Signals (128TQFP)	227
Table 5-2.	Reset Sources	228
Table 5-3.	Clock Source Options	238
Table 5-4.	Clock Source State Following POR	238
Table 5-5.	System Clock Frequency	242
Table 5-6.	System Divisor Factors for $f_{\text{VCO}}=480$ MHz	244
Table 5-7.	Actual PLL Frequency	245
Table 5-8.	Peripheral Memory Power Control	250
Table 5-9.	Maximum System Clock and PIOSC Frequency with Respect to LDO Voltage	251
Table 5-10.	MOSC Configurations	254
Table 5-11.	System Control Register Map	254
Table 5-12.	MEMTIM0 Register Configuration versus Frequency	284
Table 5-13.	MOSC Configurations	288
Table 5-14.	Maximum System Clock and PIOSC Frequency with Respect to LDO Voltage	307
Table 5-15.	Maximum System Clock and PIOSC Frequency with Respect to LDO Voltage	310
Table 5-16.	Module Power Control	458
Table 5-17.	Module Power Control	460

Table 5-18.	Module Power Control	463
Table 5-19.	Module Power Control	468
Table 5-20.	Module Power Control	470
Table 5-21.	Module Power Control	472
Table 5-22.	Module Power Control	474
Table 5-23.	Module Power Control	477
Table 5-24.	Module Power Control	479
Table 5-25.	Module Power Control	483
Table 5-26.	Module Power Control	485
Table 5-27.	Module Power Control	487
Table 5-28.	Module Power Control	489
Table 5-29.	Module Power Control	491
Table 5-30.	Module Power Control	493
Table 5-31.	Module Power Control	495
Table 5-32.	Module Power Control	497
Table 5-33.	Module Power Control	499
Table 5-34.	Module Power Control	501
Table 6-1.	System Exception Register Map	531
Table 7-1.	Hibernate Signals (128TQFP)	542
Table 7-2.	HIB Clock Source Configurations	543
Table 7-3.	Hibernation Module Register Map	560
Table 8-1.	MEMTIM0 Register Configuration versus Frequency	613
Table 8-2.	Flash Memory Protection Policy Combinations	618
Table 8-3.	User-Programmable Flash Memory Resident Registers	622
Table 8-4.	MEMTIM0 Register Configuration versus Frequency	625
Table 8-5.	Master Memory Access Availability	629
Table 8-6.	Flash Register Map	630
Table 9-1.	μDMA Channel Assignments	688
Table 9-2.	Request Type Support	690
Table 9-3.	Control Structure Memory Map	692
Table 9-4.	Channel Control Structure	692
Table 9-5.	μDMA Read Example: 8-Bit Peripheral	701
Table 9-6.	μDMA Interrupt Assignments	702
Table 9-7.	Channel Control Structure Offsets for Channel 30	703
Table 9-8.	Channel Control Word Configuration for Memory Transfer Example	704
Table 9-9.	Channel Control Structure Offsets for Channel 7	705
Table 9-10.	Channel Control Word Configuration for Peripheral Transmit Example	705
Table 9-11.	Primary and Alternate Channel Control Structure Offsets for Channel 8	707
Table 9-12.	Channel Control Word Configuration for Peripheral Ping-Pong Receive Example	707
Table 9-13.	μDMA Register Map	709
Table 10-1.	GPIO Pins With Special Considerations	751
Table 10-2.	GPIO Pins and Alternate Functions (128TQFP)	751
Table 10-3.	GPIO Drive Strength Options	761
Table 10-4.	GPIO Pad Configuration Examples	762
Table 10-5.	GPIO Interrupt Configuration Example	763
Table 10-6.	GPIO Pins With Special Considerations	764
Table 10-7.	GPIO Register Map	765

Table 10-8.	GPIO Pins With Special Considerations	778
Table 10-9.	GPIO Pins With Special Considerations	784
Table 10-10.	GPIO Pins With Special Considerations	786
Table 10-11.	GPIO Pins With Special Considerations	789
Table 10-12.	GPIO Pins With Special Considerations	795
Table 10-13.	GPIO Drive Strength Options	808
Table 11-1.	External Peripheral Interface Signals (128TQFP)	825
Table 11-2.	EPI Interface Options	830
Table 11-3.	EPI SDRAM x16 Signal Connections	831
Table 11-4.	CSCFGEXT + CSCFG Encodings	835
Table 11-5.	Dual- and Quad- Chip Select Address Mappings	836
Table 11-6.	Chip Select Configuration Register Assignment	837
Table 11-7.	Capabilities of Host Bus 8 and Host Bus 16 Modes	837
Table 11-8.	EPI Host-Bus 8 Signal Connections	839
Table 11-9.	EPI Host-Bus 16 Signal Connections	841
Table 11-10.	PSRAM Fixed Latency Wait State Configuration	846
Table 11-11.	Data Phase Wait State Programming	851
Table 11-12.	EPI General-Purpose Signal Connections	857
Table 11-13.	External Peripheral Interface (EPI) Register Map	862
Table 11-14.	CSCFGEXT + CSCFG Encodings	888
Table 11-15.	CSCFGEXT + CSCFG Encodings	894
Table 12-1.	Endian Configuration	955
Table 12-2.	Endian Configuration with Bit Reversal	955
Table 12-3.	CCM Register Map	957
Table 13-1.	Key-Block-Round Combinations	967
Table 13-2.	Interrupts and Events	976
Table 13-3.	AES Module Performance (Input/Output Block Size = 128)	977
Table 13-4.	AES Module Packet Mode Switch Overhead	978
Table 13-5.	AES Register Map	984
Table 13-6.	AES Key Register Descriptions	987
Table 14-1.	Key Repartition	1016
Table 14-2.	DES Reset Description	1018
Table 14-3.	DES Global Initialization	1020
Table 14-4.	DES Algorithm Type Configuration	1021
Table 14-5.	3DES Algorithm Type Configuration	1021
Table 14-6.	DES Interrupt Mode	1022
Table 14-7.	DES DMA Mode	1022
Table 14-8.	DES Register Map	1024
Table 14-9.	DES Key Register Mapping	1026
Table 15-1.	Interrupts and Events	1047
Table 15-2.	SHA/MD5 Module Algorithm Selection	1047
Table 15-3.	Outer Digest Registers	1048
Table 15-4.	Inner Digest Registers	1049
Table 15-5.	SHA Digest Processed in Three Passes	1051
Table 15-6.	SHA Digest Processed in One Pass	1051
Table 15-7.	SHA/MD5 Performance	1053
Table 15-8.	Continuing a Prior HMAC	1055
Table 15-9.	SHA-1 Apply on the Key	1056

Table 15-10.	Interrupt Mode	1056
Table 15-11.	DMA Mode	1057
Table 15-12.	SHA/MD5 Register Map	1058
Table 15-13.	SHA/MD5 Inner/Outer Digest/HMAC Key Register Mapping	1060
Table 16-1.	Available CCP Pins	1080
Table 16-2.	General-Purpose Timers Signals (128TQFP)	1081
Table 16-3.	General-Purpose Timer Capabilities	1082
Table 16-4.	Counter Values When the Timer is Enabled in Periodic or One-Shot Modes	1084
Table 16-5.	16-Bit Timer With Prescaler Configurations	1085
Table 16-6.	Counter Values When the Timer is Enabled in RTC Mode	1086
Table 16-7.	Counter Values When the Timer is Enabled in Input Edge-Count Mode	1087
Table 16-8.	Counter Values When the Timer is Enabled in Input Event-Count Mode	1088
Table 16-9.	Counter Values When the Timer is Enabled in PWM Mode	1090
Table 16-10.	Timeout Actions for GPTM Modes	1093
Table 16-11.	Timers Register Map	1098
Table 17-1.	Watchdog Timers Register Map	1155
Table 18-1.	ADC Signals (128TQFP)	1179
Table 18-2.	Samples and FIFO Depth of Sequencers	1180
Table 18-3.	Sample and Hold Width in ADC Clocks	1182
Table 18-4.	R_S and F_{CONV} Values with Varying N_{SH} Values and $F_{ADC} = 16$ MHz	1183
Table 18-5.	R_S and F_{CONV} Values with Varying N_{SH} Values and $F_{ADC} = 32$ MHz	1183
Table 18-6.	Differential Sampling Pairs	1190
Table 18-7.	ADC Register Map	1197
Table 18-8.	Sample and Hold Width in ADC Clocks	1251
Table 18-9.	Sample and Hold Width in ADC Clocks	1263
Table 18-10.	Sample and Hold Width in ADC Clocks	1271
Table 19-1.	UART Signals (128TQFP)	1287
Table 19-2.	Flow Control Mode	1293
Table 19-3.	UART Register Map	1297
Table 20-1.	SSI Signals (128TQFP)	1352
Table 20-2.	QSSI Transaction Encodings	1355
Table 20-3.	SSInFss Functionality	1355
Table 20-4.	Legacy Mode TI, Freescale SPI Frame Format Features	1357
Table 20-5.	SSI Register Map	1367
Table 21-1.	I ² C Signals (128TQFP)	1401
Table 21-2.	Examples of I ² C Master Timer Period Versus Speed Mode	1408
Table 21-3.	Examples of I ² C Master Timer Period in High-Speed Mode	1409
Table 21-4.	Inter-Integrated Circuit (I ² C) Interface Register Map	1424
Table 21-5.	Write Field Decoding for I2CMCS[6:0]	1432
Table 22-1.	Controller Area Network Signals (128TQFP)	1481
Table 22-2.	Message Object Configurations	1487
Table 22-3.	CAN Protocol Ranges	1495
Table 22-4.	CANBIT Register Values	1495
Table 22-5.	CAN Register Map	1499
Table 23-1.	Ethernet Signals (128TQFP)	1533
Table 23-2.	Enhanced Transmit Descriptor 0 (TDES0)	1538
Table 23-3.	Enhanced Transmit Descriptor 1 (TDES1)	1541
Table 23-4.	Enhanced Transmit Descriptor 2 (TDES2)	1542

Table 23-5.	Enhanced Transmit Descriptor 3 (TDES3)	1542
Table 23-6.	Enhanced Transmit Descriptor 6 (TDES6)	1542
Table 23-7.	Enhanced Transmit Descriptor 7 (TDES7)	1542
Table 23-8.	Enhanced Receive Descriptor 0 (RDES0)	1543
Table 23-9.	RDES0 Checksum Offload bits	1545
Table 23-10.	Enhanced Receive Descriptor 1 (RDES1)	1546
Table 23-11.	Enhanced Receive Descriptor 2 (RDES2)	1546
Table 23-12.	Enhanced Receive Descriptor 3 (RDES3)	1546
Table 23-13.	Enhanced Received Descriptor 4 (RDES4)	1546
Table 23-14.	Enhanced Receive Descriptor 6 (RDES6)	1548
Table 23-15.	Enhanced Receive Descriptor 7 (RDES7)	1548
Table 23-16.	TX MAC Flow Control	1561
Table 23-17.	RX MAC Flow Control	1561
Table 23-18.	VLAN Match Status	1574
Table 23-19.	CRC Replacement Based on Bit 27 and Bit 24 of TDES0	1576
Table 23-20.	Forced Mode Configurations	1582
Table 23-21.	Advertised Mode Configurations	1583
Table 23-22.	EMACPC to PHY Register Mapping	1589
Table 23-23.	Ethernet Register Map	1591
Table 23-24.	PPSCTRL Bit Field Values	1673
Table 24-1.	USB Signals (128TQFP)	1770
Table 24-2.	List of Registers	1771
Table 25-1.	Analog Comparators Signals (128TQFP)	1778
Table 25-2.	Internal Reference Voltage and ACREFLCTL Field Values	1780
Table 25-3.	Analog Comparator Voltage Reference Characteristics, $V_{DDA} = 3.3V$, EN= 1, and RNG = 0	1781
Table 25-4.	Analog Comparator Voltage Reference Characteristics, $V_{DDA} = 3.3V$, EN= 1, and RNG = 1	1782
Table 25-5.	Analog Comparators Register Map	1783
Table 26-1.	PWM Signals (128TQFP)	1796
Table 26-2.	PWM Register Map	1803
Table 27-1.	QEI Signals (128TQFP)	1874
Table 27-2.	QEI Register Map	1878
Table 29-1.	GPIO Pins With Special Considerations	1896
Table 29-2.	Signals by Pin Number	1897
Table 29-3.	Signals by Signal Name	1909
Table 29-4.	Signals by Function, Except for GPIO	1921
Table 29-5.	GPIO Pins and Alternate Functions	1932
Table 29-6.	Possible Pin Assignments for Alternate Functions	1935
Table 29-7.	Connections for Unused Signals (128-Pin TQFP)	1940
Table 30-1.	Absolute Maximum Ratings	1942
Table 30-2.	ESD Absolute Maximum Ratings	1942
Table 30-3.	Temperature Characteristics	1943
Table 30-4.	128-pin TQFP Power Dissipation	1943
Table 30-5.	Thermal Characteristics	1943
Table 30-6.	Recommended DC Operating Conditions	1944
Table 30-7.	Recommended FAST GPIO Pad Operating Conditions	1944
Table 30-8.	Recommended Slow GPIO Pad Operating Conditions	1945

Table 30-9.	GPIO Current Restrictions	1945
Table 30-10.	Maximum GPIO Package Side Assignments	1946
Table 30-11.	Load Conditions	1947
Table 30-12.	JTAG Characteristics	1948
Table 30-13.	Power and Brown-Out Levels	1950
Table 30-14.	Reset Characteristics	1955
Table 30-15.	LDO Regulator Characteristics	1958
Table 30-16.	Phase Locked Loop (PLL) Characteristics	1959
Table 30-17.	System Divisor Factors for $f_{VCO}=480$ MHz	1960
Table 30-18.	Actual PLL Frequency	1960
Table 30-19.	PIOSC Clock Characteristics	1961
Table 30-20.	Low-Frequency Oscillator Characteristics	1961
Table 30-21.	Hibernation Internal Low Frequency Oscillator Clock Characteristics	1961
Table 30-22.	Hibernation External Oscillator (XOSC) Input Characteristics	1961
Table 30-23.	Main Oscillator Input Characteristics	1962
Table 30-24.	Crystal Parameters	1964
Table 30-25.	System Clock Characteristics with ADC Operation	1966
Table 30-26.	System Clock Characteristics with USB Operation	1966
Table 30-27.	Wake from Sleep Characteristics	1967
Table 30-28.	Wake from Deep Sleep Characteristics	1967
Table 30-29.	Hibernation Module Battery Characteristics	1969
Table 30-30.	Hibernation Module Characteristics	1969
Table 30-31.	Hibernation Module Tamper I/O Characteristics	1969
Table 30-32.	Flash Memory Characteristics	1971
Table 30-33.	EEPROM Characteristics	1972
Table 30-34.	Fast GPIO Module Characteristics	1973
Table 30-35.	Slow GPIO Module Characteristics	1974
Table 30-36.	Pad Voltage/Current Characteristics for Hibernate \overline{WAKE} Pin	1975
Table 30-37.	Non-Power I/O Pad Voltage/Current Characteristics	1976
Table 30-38.	EPI Interface Load Conditions	1977
Table 30-39.	EPI SDRAM Characteristics	1977
Table 30-40.	EPI SDRAM Interface Characteristics	1977
Table 30-41.	EPI Host-Bus 8 and Host-Bus 16 Interface Characteristics	1979
Table 30-42.	EPI General-Purpose Interface Characteristics	1981
Table 30-43.	EPI PSRAM Interface Characteristics	1982
Table 30-44.	ADC Electrical Characteristics for ADC at 1 Msps	1985
Table 30-45.	ADC Electrical Characteristics for ADC at 2 Msps	1987
Table 30-46.	SSI Characteristics	1991
Table 30-47.	Bi- and Quad-SSI Characteristics	1993
Table 30-48.	I ² C Characteristics	1994
Table 30-49.	Ethernet PHY DC Characteristics	1995
Table 30-50.	MOSC 25-MHz Crystal Specification	1995
Table 30-51.	MOSC Single-Ended 25-MHz Oscillator Specification ^a	1995
Table 30-52.	Ethernet Controller Enable and Software Reset Timing	1996
Table 30-53.	100Base-TX Transmit Timing ($t_{R/F}$ and Jitter)	1996
Table 30-54.	10Base-T Normal Link Pulse Timing	1997
Table 30-55.	Auto-Negotiation Fast Link Pulse (FLP) Timing	1998
Table 30-56.	100Base-TX Signal Detect Timing	1998

Table 30-57.	ULPI Interface Timing	1999
Table 30-58.	Analog Comparator Characteristics	2001
Table 30-59.	Analog Comparator Voltage Reference Characteristics	2001
Table 30-60.	Analog Comparator Voltage Reference Characteristics, $V_{DDA} = 3.3V$, EN= 1, and RNG = 0	2001
Table 30-61.	Analog Comparator Voltage Reference Characteristics, $V_{DDA} = 3.3V$, EN= 1, and RNG = 1	2002
Table 30-62.	PWM Timing Characteristics	2003
Table 30-63.	Current Consumption	2004
Table 30-64.	Peripheral Current Consumption	2008

List of Registers

The Cortex-M4F Processor	86
Register 1: Cortex General-Purpose Register 0 (R0)	94
Register 2: Cortex General-Purpose Register 1 (R1)	94
Register 3: Cortex General-Purpose Register 2 (R2)	94
Register 4: Cortex General-Purpose Register 3 (R3)	94
Register 5: Cortex General-Purpose Register 4 (R4)	94
Register 6: Cortex General-Purpose Register 5 (R5)	94
Register 7: Cortex General-Purpose Register 6 (R6)	94
Register 8: Cortex General-Purpose Register 7 (R7)	94
Register 9: Cortex General-Purpose Register 8 (R8)	94
Register 10: Cortex General-Purpose Register 9 (R9)	94
Register 11: Cortex General-Purpose Register 10 (R10)	94
Register 12: Cortex General-Purpose Register 11 (R11)	94
Register 13: Cortex General-Purpose Register 12 (R12)	94
Register 14: Stack Pointer (SP)	95
Register 15: Link Register (LR)	96
Register 16: Program Counter (PC)	97
Register 17: Program Status Register (PSR)	98
Register 18: Priority Mask Register (PRIMASK)	102
Register 19: Fault Mask Register (FAULTMASK)	103
Register 20: Base Priority Mask Register (BASEPRI)	104
Register 21: Control Register (CONTROL)	105
Register 22: Floating-Point Status Control (FPSC)	107
Cortex-M4 Peripherals	141
Register 1: SysTick Control and Status Register (STCTRL), offset 0x010	157
Register 2: SysTick Reload Value Register (STRELOAD), offset 0x014	159
Register 3: SysTick Current Value Register (STCURRENT), offset 0x018	160
Register 4: Interrupt 0-31 Set Enable (EN0), offset 0x100	161
Register 5: Interrupt 32-63 Set Enable (EN1), offset 0x104	161
Register 6: Interrupt 64-95 Set Enable (EN2), offset 0x108	161
Register 7: Interrupt 96-113 Set Enable (EN3), offset 0x10C	161
Register 8: Interrupt 0-31 Clear Enable (DIS0), offset 0x180	162
Register 9: Interrupt 32-63 Clear Enable (DIS1), offset 0x184	162
Register 10: Interrupt 64-95 Clear Enable (DIS2), offset 0x188	162
Register 11: Interrupt 96-113 Clear Enable (DIS3), offset 0x18C	162
Register 12: Interrupt 0-31 Set Pending (PEND0), offset 0x200	163
Register 13: Interrupt 32-63 Set Pending (PEND1), offset 0x204	163
Register 14: Interrupt 64-95 Set Pending (PEND2), offset 0x208	163
Register 15: Interrupt 96-113 Set Pending (PEND3), offset 0x20C	163
Register 16: Interrupt 0-31 Clear Pending (UNPEND0), offset 0x280	164
Register 17: Interrupt 32-63 Clear Pending (UNPEND1), offset 0x284	164
Register 18: Interrupt 64-95 Clear Pending (UNPEND2), offset 0x288	164
Register 19: Interrupt 96-113 Clear Pending (UNPEND3), offset 0x28C	164
Register 20: Interrupt 0-31 Active Bit (ACTIVE0), offset 0x300	165
Register 21: Interrupt 32-63 Active Bit (ACTIVE1), offset 0x304	165

Register 22:	Interrupt 64-95 Active Bit (ACTIVE2), offset 0x308	165
Register 23:	Interrupt 96-127 Active Bit (ACTIVE3), offset 0x30C	165
Register 24:	Interrupt 0-3 Priority (PRI0), offset 0x400	166
Register 25:	Interrupt 4-7 Priority (PRI1), offset 0x404	166
Register 26:	Interrupt 8-11 Priority (PRI2), offset 0x408	166
Register 27:	Interrupt 12-15 Priority (PRI3), offset 0x40C	166
Register 28:	Interrupt 16-19 Priority (PRI4), offset 0x410	166
Register 29:	Interrupt 20-23 Priority (PRI5), offset 0x414	166
Register 30:	Interrupt 24-27 Priority (PRI6), offset 0x418	166
Register 31:	Interrupt 28-31 Priority (PRI7), offset 0x41C	166
Register 32:	Interrupt 32-35 Priority (PRI8), offset 0x420	166
Register 33:	Interrupt 36-39 Priority (PRI9), offset 0x424	166
Register 34:	Interrupt 40-43 Priority (PRI10), offset 0x428	166
Register 35:	Interrupt 44-47 Priority (PRI11), offset 0x42C	166
Register 36:	Interrupt 48-51 Priority (PRI12), offset 0x430	166
Register 37:	Interrupt 52-55 Priority (PRI13), offset 0x434	166
Register 38:	Interrupt 56-59 Priority (PRI14), offset 0x438	166
Register 39:	Interrupt 60-63 Priority (PRI15), offset 0x43C	166
Register 40:	Interrupt 64-67 Priority (PRI16), offset 0x440	168
Register 41:	Interrupt 68-71 Priority (PRI17), offset 0x444	168
Register 42:	Interrupt 72-75 Priority (PRI18), offset 0x448	168
Register 43:	Interrupt 76-79 Priority (PRI19), offset 0x44C	168
Register 44:	Interrupt 80-83 Priority (PRI20), offset 0x450	168
Register 45:	Interrupt 84-87 Priority (PRI21), offset 0x454	168
Register 46:	Interrupt 88-91 Priority (PRI22), offset 0x458	168
Register 47:	Interrupt 92-95 Priority (PRI23), offset 0x45C	168
Register 48:	Interrupt 96-99 Priority (PRI24), offset 0x460	168
Register 49:	Interrupt 100-103 Priority (PRI25), offset 0x464	168
Register 50:	Interrupt 104-107 Priority (PRI26), offset 0x468	168
Register 51:	Interrupt 108-111 Priority (PRI27), offset 0x46C	168
Register 52:	Interrupt 112-113 Priority (PRI28), offset 0x470	168
Register 53:	Software Trigger Interrupt (SWTRIG), offset 0xF00	170
Register 54:	Auxiliary Control (ACTLR), offset 0x008	171
Register 55:	CPU ID Base (CPUID), offset 0xD00	173
Register 56:	Interrupt Control and State (INTCTRL), offset 0xD04	174
Register 57:	Vector Table Offset (VTABLE), offset 0xD08	177
Register 58:	Application Interrupt and Reset Control (APINT), offset 0xD0C	178
Register 59:	System Control (SYSCTRL), offset 0xD10	180
Register 60:	Configuration and Control (CFGCTRL), offset 0xD14	182
Register 61:	System Handler Priority 1 (SYSPRI1), offset 0xD18	184
Register 62:	System Handler Priority 2 (SYSPRI2), offset 0xD1C	185
Register 63:	System Handler Priority 3 (SYSPRI3), offset 0xD20	186
Register 64:	System Handler Control and State (SYSHNDCTRL), offset 0xD24	187
Register 65:	Configurable Fault Status (FAULTSTAT), offset 0xD28	191
Register 66:	Hard Fault Status (HFAULTSTAT), offset 0xD2C	197
Register 67:	Memory Management Fault Address (MMADDR), offset 0xD34	198
Register 68:	Bus Fault Address (FAULTADDR), offset 0xD38	199
Register 69:	MPU Type (MPUTYPE), offset 0xD90	200

Register 70:	MPU Control (MPUCTRL), offset 0xD94	201
Register 71:	MPU Region Number (MPUNUMBER), offset 0xD98	203
Register 72:	MPU Region Base Address (MPUBASE), offset 0xD9C	204
Register 73:	MPU Region Base Address Alias 1 (MPUBASE1), offset 0xDA4	204
Register 74:	MPU Region Base Address Alias 2 (MPUBASE2), offset 0xDAC	204
Register 75:	MPU Region Base Address Alias 3 (MPUBASE3), offset 0xDB4	204
Register 76:	MPU Region Attribute and Size (MPUATTR), offset 0xDA0	206
Register 77:	MPU Region Attribute and Size Alias 1 (MPUATTR1), offset 0xDA8	206
Register 78:	MPU Region Attribute and Size Alias 2 (MPUATTR2), offset 0xDB0	206
Register 79:	MPU Region Attribute and Size Alias 3 (MPUATTR3), offset 0xDB8	206
Register 80:	Coprocessor Access Control (CPAC), offset 0xD88	209
Register 81:	Floating-Point Context Control (FPCC), offset 0xF34	210
Register 82:	Floating-Point Context Address (FPCA), offset 0xF38	212
Register 83:	Floating-Point Default Status Control (FPDSC), offset 0xF3C	213
System Control	227	
Register 1:	Device Identification 0 (DID0), offset 0x000	262
Register 2:	Device Identification 1 (DID1), offset 0x004	264
Register 3:	Power-Temp Brown Out Control (PTBOCTL), offset 0x038	266
Register 4:	Raw Interrupt Status (RIS), offset 0x050	268
Register 5:	Interrupt Mask Control (IMC), offset 0x054	270
Register 6:	Masked Interrupt Status and Clear (MISC), offset 0x058	272
Register 7:	Reset Cause (RESC), offset 0x05C	274
Register 8:	Power-Temperature Cause (PWRTC), offset 0x060	277
Register 9:	NMI Cause Register (NMIC), offset 0x064	278
Register 10:	Main Oscillator Control (MOSCCTL), offset 0x07C	280
Register 11:	Run and Sleep Mode Configuration Register (RSCLKCFG), offset 0x0B0	282
Register 12:	Memory Timing Parameter Register 0 for Main Flash and EEPROM (MEMTIM0), offset 0x0C0	284
Register 13:	Alternate Clock Configuration (ALTCLKCFG), offset 0x138	287
Register 14:	Deep Sleep Clock Configuration Register (DSCLKCFG), offset 0x144	288
Register 15:	Divisor and Source Clock Configuration (DIVSCLK), offset 0x148	291
Register 16:	System Properties (SYSPROP), offset 0x14C	293
Register 17:	Precision Internal Oscillator Calibration (PIOSCCAL), offset 0x150	296
Register 18:	Precision Internal Oscillator Statistics (PIOSCSTAT), offset 0x154	298
Register 19:	PLL Frequency 0 (PLLREQ0), offset 0x160	299
Register 20:	PLL Frequency 1 (PLLREQ1), offset 0x164	300
Register 21:	PLL Status (PLLSTAT), offset 0x168	301
Register 22:	Sleep Power Configuration (SLPPWRCFG), offset 0x188	302
Register 23:	Deep-Sleep Power Configuration (DSLPPWRCFG), offset 0x18C	304
Register 24:	Non-Volatile Memory Information (NVMSTAT), offset 0x1A0	306
Register 25:	LDO Sleep Power Control (LDOSPCTL), offset 0x1B4	307
Register 26:	LDO Sleep Power Calibration (LDOSPCAL), offset 0x1B8	309
Register 27:	LDO Deep-Sleep Power Control (LDODPCTL), offset 0x1BC	310
Register 28:	LDO Deep-Sleep Power Calibration (LDODPCAL), offset 0x1C0	312
Register 29:	Sleep / Deep-Sleep Power Mode Status (SDPMST), offset 0x1CC	313
Register 30:	Reset Behavior Control Register (RESBEHAVCTL), offset 0x1D8	316
Register 31:	Hardware System Service Request (HSSR), offset 0x1F4	318
Register 32:	USB Power Domain Status (USBPDS), offset 0x280	319

Register 33:	USB Memory Power Control (USBMPC), offset 0x284	320
Register 34:	Ethernet MAC Power Domain Status (EMACPDS), offset 0x288	321
Register 35:	Ethernet MAC Memory Power Control (EMACMPC), offset 0x28C	322
Register 36:	CAN 0 Power Domain Status (CAN0PDS), offset 0x298	323
Register 37:	CAN 0 Memory Power Control (CAN0MPC), offset 0x29C	324
Register 38:	CAN 1 Power Domain Status (CAN1PDS), offset 0x2A0	325
Register 39:	CAN 1 Memory Power Control (CAN1MPC), offset 0x2A4	326
Register 40:	Watchdog Timer Peripheral Present (PPWD), offset 0x300	327
Register 41:	16/32-Bit General-Purpose Timer Peripheral Present (PPTIMER), offset 0x304	328
Register 42:	General-Purpose Input/Output Peripheral Present (PPGPIO), offset 0x308	330
Register 43:	Micro Direct Memory Access Peripheral Present (PPDMA), offset 0x30C	333
Register 44:	EPI Peripheral Present (PPEPI), offset 0x310	334
Register 45:	Hibernation Peripheral Present (PPHIB), offset 0x314	335
Register 46:	Universal Asynchronous Receiver/Transmitter Peripheral Present (PPUART), offset 0x318	336
Register 47:	Synchronous Serial Interface Peripheral Present (PPSSI), offset 0x31C	338
Register 48:	Inter-Integrated Circuit Peripheral Present (PPI2C), offset 0x320	340
Register 49:	Universal Serial Bus Peripheral Present (PPUSB), offset 0x328	342
Register 50:	Ethernet PHY Peripheral Present (PPEPHY), offset 0x330	343
Register 51:	Controller Area Network Peripheral Present (PPCAN), offset 0x334	344
Register 52:	Analog-to-Digital Converter Peripheral Present (PPADC), offset 0x338	345
Register 53:	Analog Comparator Peripheral Present (PPACMP), offset 0x33C	346
Register 54:	Pulse Width Modulator Peripheral Present (PPPWM), offset 0x340	347
Register 55:	Quadrature Encoder Interface Peripheral Present (PPQEI), offset 0x344	348
Register 56:	Low Pin Count Interface Peripheral Present (PPLPC), offset 0x348	349
Register 57:	Platform Environment Control Interface Peripheral Present (PPPECI), offset 0x350	350
Register 58:	Fan Control Peripheral Present (PPFAN), offset 0x354	351
Register 59:	EEPROM Peripheral Present (PPEEPROM), offset 0x358	352
Register 60:	32/64-Bit Wide General-Purpose Timer Peripheral Present (PPWTIMER), offset 0x35C	353
Register 61:	Remote Temperature Sensor Peripheral Present (PPRTS), offset 0x370	354
Register 62:	CRC and Cryptographic Modules Peripheral Present (PPCCM), offset 0x374	355
Register 63:	LCD Peripheral Present (PPLCD), offset 0x390	356
Register 64:	1-Wire Peripheral Present (PPOWIRE), offset 0x398	357
Register 65:	Ethernet MAC Peripheral Present (PPEMAC), offset 0x39C	358
Register 66:	Power Regulator Bus Peripheral Present (PPPRB), offset 0x3A0	359
Register 67:	Human Interface Master Peripheral Present (PPHIM), offset 0x3A4	360
Register 68:	Watchdog Timer Software Reset (SRWD), offset 0x500	361
Register 69:	16/32-Bit General-Purpose Timer Software Reset (SRTIMER), offset 0x504	362
Register 70:	General-Purpose Input/Output Software Reset (SRGPIO), offset 0x508	364
Register 71:	Micro Direct Memory Access Software Reset (SRDMA), offset 0x50C	367
Register 72:	EPI Software Reset (SREPI), offset 0x510	368
Register 73:	Hibernation Software Reset (SRHIB), offset 0x514	369
Register 74:	Universal Asynchronous Receiver/Transmitter Software Reset (SRUART), offset 0x518	370
Register 75:	Synchronous Serial Interface Software Reset (SRSSI), offset 0x51C	372
Register 76:	Inter-Integrated Circuit Software Reset (SRI2C), offset 0x520	374
Register 77:	Universal Serial Bus Software Reset (SRUSB), offset 0x528	376
Register 78:	Ethernet PHY Software Reset (SREPHY), offset 0x530	377
Register 79:	Controller Area Network Software Reset (SRCAN), offset 0x534	378

Register 80:	Analog-to-Digital Converter Software Reset (SRADC), offset 0x538	379
Register 81:	Analog Comparator Software Reset (SRACMP), offset 0x53C	380
Register 82:	Pulse Width Modulator Software Reset (SRPWM), offset 0x540	381
Register 83:	Quadrature Encoder Interface Software Reset (SRQEI), offset 0x544	382
Register 84:	EEPROM Software Reset (SREEPROM), offset 0x558	383
Register 85:	CRC and Cryptographic Modules Software Reset (SRCCM), offset 0x574	384
Register 86:	Ethernet MAC Software Reset (SREMAC), offset 0x59C	385
Register 87:	Watchdog Timer Run Mode Clock Gating Control (RCGCWD), offset 0x600	386
Register 88:	16/32-Bit General-Purpose Timer Run Mode Clock Gating Control (RCGCTIMER), offset 0x604	387
Register 89:	General-Purpose Input/Output Run Mode Clock Gating Control (RCGCGPIO), offset 0x608	389
Register 90:	Micro Direct Memory Access Run Mode Clock Gating Control (RCGCDMA), offset 0x60C	392
Register 91:	EPI Run Mode Clock Gating Control (RCGCEPI), offset 0x610	393
Register 92:	Hibernation Run Mode Clock Gating Control (RCGCHIB), offset 0x614	394
Register 93:	Universal Asynchronous Receiver/Transmitter Run Mode Clock Gating Control (RCGCUART), offset 0x618	395
Register 94:	Synchronous Serial Interface Run Mode Clock Gating Control (RCGCSSI), offset 0x61C	397
Register 95:	Inter-Integrated Circuit Run Mode Clock Gating Control (RCGCI2C), offset 0x620	398
Register 96:	Universal Serial Bus Run Mode Clock Gating Control (RCGCUSB), offset 0x628	400
Register 97:	Ethernet PHY Run Mode Clock Gating Control (RCGCEPHY), offset 0x630	401
Register 98:	Controller Area Network Run Mode Clock Gating Control (RCGCCAN), offset 0x634	402
Register 99:	Analog-to-Digital Converter Run Mode Clock Gating Control (RCGCADC), offset 0x638	403
Register 100:	Analog Comparator Run Mode Clock Gating Control (RCGCACMP), offset 0x63C	404
Register 101:	Pulse Width Modulator Run Mode Clock Gating Control (RCGCPWM), offset 0x640	405
Register 102:	Quadrature Encoder Interface Run Mode Clock Gating Control (RCGCQEI), offset 0x644	406
Register 103:	EEPROM Run Mode Clock Gating Control (RCGC EEPROM), offset 0x658	407
Register 104:	CRC and Cryptographic Modules Run Mode Clock Gating Control (RCGCCCM), offset 0x674	408
Register 105:	Ethernet MAC Run Mode Clock Gating Control (RCGCEMAC), offset 0x69C	409
Register 106:	Watchdog Timer Sleep Mode Clock Gating Control (SCGCWD), offset 0x700	410
Register 107:	16/32-Bit General-Purpose Timer Sleep Mode Clock Gating Control (SCGCTIMER), offset 0x704	411
Register 108:	General-Purpose Input/Output Sleep Mode Clock Gating Control (SCGCGPIO), offset 0x708	413
Register 109:	Micro Direct Memory Access Sleep Mode Clock Gating Control (SCGCDMA), offset 0x70C	416
Register 110:	EPI Sleep Mode Clock Gating Control (SCGCEPI), offset 0x710	417
Register 111:	Hibernation Sleep Mode Clock Gating Control (SCGCHIB), offset 0x714	418
Register 112:	Universal Asynchronous Receiver/Transmitter Sleep Mode Clock Gating Control (SCGCUART), offset 0x718	419
Register 113:	Synchronous Serial Interface Sleep Mode Clock Gating Control (SCGCSSI), offset 0x71C	421
Register 114:	Inter-Integrated Circuit Sleep Mode Clock Gating Control (SCGCI2C), offset 0x720	422
Register 115:	Universal Serial Bus Sleep Mode Clock Gating Control (SCGCUSB), offset 0x728	424
Register 116:	Ethernet PHY Sleep Mode Clock Gating Control (SCGCEPHY), offset 0x730	425

Register 117: Controller Area Network Sleep Mode Clock Gating Control (SCGCCAN), offset 0x734	426
Register 118: Analog-to-Digital Converter Sleep Mode Clock Gating Control (SCGCADC), offset 0x738	427
Register 119: Analog Comparator Sleep Mode Clock Gating Control (SCGCACMP), offset 0x73C	428
Register 120: Pulse Width Modulator Sleep Mode Clock Gating Control (SCGCPWM), offset 0x740	429
Register 121: Quadrature Encoder Interface Sleep Mode Clock Gating Control (SCGCQEI), offset 0x744	430
Register 122: EEPROM Sleep Mode Clock Gating Control (SCGCEEPROM), offset 0x758	431
Register 123: CRC and Cryptographic Modules Sleep Mode Clock Gating Control (SCGCCCM), offset 0x774	432
Register 124: Ethernet MAC Sleep Mode Clock Gating Control (SCGCEMAC), offset 0x79C	433
Register 125: Watchdog Timer Deep-Sleep Mode Clock Gating Control (DCGCWD), offset 0x800	434
Register 126: 16/32-Bit General-Purpose Timer Deep-Sleep Mode Clock Gating Control (DCGCTIMER), offset 0x804	435
Register 127: General-Purpose Input/Output Deep-Sleep Mode Clock Gating Control (DCGCGPIO), offset 0x808	437
Register 128: Micro Direct Memory Access Deep-Sleep Mode Clock Gating Control (DCGCDMA), offset 0x80C	440
Register 129: EPI Deep-Sleep Mode Clock Gating Control (DCGCEPI), offset 0x810	441
Register 130: Hibernation Deep-Sleep Mode Clock Gating Control (DCGCHIB), offset 0x814	442
Register 131: Universal Asynchronous Receiver/Transmitter Deep-Sleep Mode Clock Gating Control (DCGCUART), offset 0x818	443
Register 132: Synchronous Serial Interface Deep-Sleep Mode Clock Gating Control (DCGCSSI), offset 0x81C	445
Register 133: Inter-Integrated Circuit Deep-Sleep Mode Clock Gating Control (DCGCI2C), offset 0x820	446
Register 134: Universal Serial Bus Deep-Sleep Mode Clock Gating Control (DCGCUSB), offset 0x828	448
Register 135: Ethernet PHY Deep-Sleep Mode Clock Gating Control (DCGCEPHY), offset 0x830	449
Register 136: Controller Area Network Deep-Sleep Mode Clock Gating Control (DCGCCAN), offset 0x834	450
Register 137: Analog-to-Digital Converter Deep-Sleep Mode Clock Gating Control (DCGCADC), offset 0x838	451
Register 138: Analog Comparator Deep-Sleep Mode Clock Gating Control (DCGCACMP), offset 0x83C	452
Register 139: Pulse Width Modulator Deep-Sleep Mode Clock Gating Control (DCGCPWM), offset 0x840	453
Register 140: Quadrature Encoder Interface Deep-Sleep Mode Clock Gating Control (DCGCQEI), offset 0x844	454
Register 141: EEPROM Deep-Sleep Mode Clock Gating Control (DCGCEEPROM), offset 0x858	455
Register 142: CRC and Cryptographic Modules Deep-Sleep Mode Clock Gating Control (DCGCCCM), offset 0x874	456
Register 143: Ethernet MAC Deep-Sleep Mode Clock Gating Control (DCGCEMAC), offset 0x89C	457
Register 144: Watchdog Timer Power Control (PCWD), offset 0x900	458
Register 145: 16/32-Bit General-Purpose Timer Power Control (PCTIMER), offset 0x904	460
Register 146: General-Purpose Input/Output Power Control (PCGPIO), offset 0x908	463
Register 147: Micro Direct Memory Access Power Control (PCDMA), offset 0x90C	468
Register 148: External Peripheral Interface Power Control (PCEPI), offset 0x910	470
Register 149: Hibernation Power Control (PCHIB), offset 0x914	472
Register 150: Universal Asynchronous Receiver/Transmitter Power Control (PCUART), offset 0x918	474

Register 151: Synchronous Serial Interface Power Control (PCSSI), offset 0x91C	477
Register 152: Inter-Integrated Circuit Power Control (PCI2C), offset 0x920	479
Register 153: Universal Serial Bus Power Control (PCUSB), offset 0x928	483
Register 154: Ethernet PHY Power Control (PCEPHY), offset 0x930	485
Register 155: Controller Area Network Power Control (PCCAN), offset 0x934	487
Register 156: Analog-to-Digital Converter Power Control (PCADC), offset 0x938	489
Register 157: Analog Comparator Power Control (PCACMP), offset 0x93C	491
Register 158: Pulse Width Modulator Power Control (PCPWM), offset 0x940	493
Register 159: Quadrature Encoder Interface Power Control (PCQEI), offset 0x944	495
Register 160: EEPROM Power Control (PCEEPROM), offset 0x958	497
Register 161: CRC and Cryptographic Modules Power Control (PCCCM), offset 0x974	499
Register 162: Ethernet MAC Power Control (PCEMAC), offset 0x99C	501
Register 163: Watchdog Timer Peripheral Ready (PRWD), offset 0xA00	503
Register 164: 16/32-Bit General-Purpose Timer Peripheral Ready (PRTIMER), offset 0xA04	504
Register 165: General-Purpose Input/Output Peripheral Ready (PRGPIO), offset 0xA08	506
Register 166: Micro Direct Memory Access Peripheral Ready (PRDMA), offset 0xA0C	509
Register 167: EPI Peripheral Ready (PREPI), offset 0xA10	510
Register 168: Hibernation Peripheral Ready (PRHIB), offset 0xA14	511
Register 169: Universal Asynchronous Receiver/Transmitter Peripheral Ready (PRUART), offset 0xA18	512
Register 170: Synchronous Serial Interface Peripheral Ready (PRSSI), offset 0xA1C	514
Register 171: Inter-Integrated Circuit Peripheral Ready (PRI2C), offset 0xA20	516
Register 172: Universal Serial Bus Peripheral Ready (PRUSB), offset 0xA28	519
Register 173: Ethernet PHY Peripheral Ready (PREPHY), offset 0xA30	520
Register 174: Controller Area Network Peripheral Ready (PRCAN), offset 0xA34	521
Register 175: Analog-to-Digital Converter Peripheral Ready (PRADC), offset 0xA38	522
Register 176: Analog Comparator Peripheral Ready (PRACMP), offset 0xA3C	523
Register 177: Pulse Width Modulator Peripheral Ready (PRPWM), offset 0xA40	524
Register 178: Quadrature Encoder Interface Peripheral Ready (PRQEI), offset 0xA44	525
Register 179: EEPROM Peripheral Ready (PREEPROM), offset 0xA58	526
Register 180: CRC and Cryptographic Modules Peripheral Ready (PRCCM), offset 0xA74	527
Register 181: Ethernet MAC Peripheral Ready (PREMAC), offset 0xA9C	528
Register 182: Unique ID 0 (UNIQUEID0), offset 0xF20	529
Register 183: Unique ID 1 (UNIQUEID1), offset 0xF24	529
Register 184: Unique ID 2 (UNIQUEID2), offset 0xF28	529
Register 185: Unique ID 3 (UNIQUEID3), offset 0xF2C	529
Register 186: Cryptographic Modules Clock Gating Request (CCMCGREQ), offset 0x204	530
Processor Support and Exception Module	531
Register 1: System Exception Raw Interrupt Status (SYSEXCRI), offset 0x000	532
Register 2: System Exception Interrupt Mask (SYSEXCIM), offset 0x004	534
Register 3: System Exception Masked Interrupt Status (SYSEXCMI), offset 0x008	536
Register 4: System Exception Interrupt Clear (SYSEXCIC), offset 0x00C	538
Hibernation Module	539
Register 1: Hibernation RTC Counter (HIBRTCC), offset 0x000	562
Register 2: Hibernation RTC Match 0 (HIBRTCM0), offset 0x004	563
Register 3: Hibernation RTC Load (HIBRTCLD), offset 0x00C	564
Register 4: Hibernation Control (HIBCTL), offset 0x010	565
Register 5: Hibernation Interrupt Mask (HIBIM), offset 0x014	570

Register 6:	Hibernation Raw Interrupt Status (HIBRIS), offset 0x018	572
Register 7:	Hibernation Masked Interrupt Status (HIBMIS), offset 0x01C	574
Register 8:	Hibernation Interrupt Clear (HIBIC), offset 0x020	576
Register 9:	Hibernation RTC Trim (HIBRTCT), offset 0x024	578
Register 10:	Hibernation RTC Sub Seconds (HIBRTCSS), offset 0x028	579
Register 11:	Hibernation IO Configuration (HIBIO), offset 0x02C	580
Register 12:	Hibernation Data (HIBDATA), offset 0x030-0x06F	582
Register 13:	Hibernation Calendar Control (HIBCALCTL), offset 0x300	583
Register 14:	Hibernation Calendar 0 (HIBCAL0), offset 0x310	584
Register 15:	Hibernation Calendar 1 (HIBCAL1), offset 0x314	586
Register 16:	Hibernation Calendar Load 0 (HIBCALLD0), offset 0x320	588
Register 17:	Hibernation Calendar Load (HIBCALLD1), offset 0x324	590
Register 18:	Hibernation Calendar Match 0 (HIBCALM0), offset 0x330	591
Register 19:	Hibernation Calendar Match 1 (HIBCALM1), offset 0x334	593
Register 20:	Hibernation Lock (HIBLOCK), offset 0x360	594
Register 21:	HIB Tamper Control (HIBTPCTL), offset 0x400	595
Register 22:	HIB Tamper Status (HIBTPSTAT), offset 0x404	597
Register 23:	HIB Tamper I/O Control (HIBTPIO), offset 0x410	599
Register 24:	HIB Tamper Log 0 (HIBTPLOG0), offset 0x4E0	603
Register 25:	HIB Tamper Log 2 (HIBTPLOG2), offset 0x4E8	603
Register 26:	HIB Tamper Log 4 (HIBTPLOG4), offset 0x4F0	603
Register 27:	HIB Tamper Log 6 (HIBTPLOG6), offset 0x4F8	603
Register 28:	HIB Tamper Log 1 (HIBTPLOG1), offset 0x4E4	604
Register 29:	HIB Tamper Log 3 (HIBTPLOG3), offset 0x4EC	604
Register 30:	HIB Tamper Log 5 (HIBTPLOG5), offset 0x4F4	604
Register 31:	HIB Tamper Log 7 (HIBTPLOG7), offset 0x4FC	604
Register 32:	Hibernation Peripheral Properties (HIBPP) , offset 0xFC0	606
Register 33:	Hibernation Clock Control (HIBCC), offset 0xFC8	607
Internal Memory		608
Register 1:	Flash Memory Address (FMA), offset 0x000	633
Register 2:	Flash Memory Data (FMD), offset 0x004	634
Register 3:	Flash Memory Control (FMC), offset 0x008	635
Register 4:	Flash Controller Raw Interrupt Status (FCRIS), offset 0x00C	638
Register 5:	Flash Controller Interrupt Mask (FCIM), offset 0x010	641
Register 6:	Flash Controller Masked Interrupt Status and Clear (FCMISC), offset 0x014	643
Register 7:	Flash Memory Control 2 (FMC2), offset 0x020	646
Register 8:	Flash Write Buffer Valid (FWBVAL), offset 0x030	647
Register 9:	Flash Program/Erase Key (FLPEKEY), offset 0x03C	648
Register 10:	Flash Write Buffer n (FWBn), offset 0x100 - 0x17C	649
Register 11:	Flash Peripheral Properties (FLASHPP), offset 0xFC0	650
Register 12:	SRAM Size (SSIZE), offset 0xFC4	652
Register 13:	Flash Configuration Register (FLASHCONF), offset 0xFC8	653
Register 14:	ROM Third-Party Software (ROMSWMAP), offset 0xFCC	655
Register 15:	Flash DMA Address Size (FLASHDMASZ), offset 0xFD0	657
Register 16:	Flash DMA Starting Address (FLASHDMAST), offset 0xFD4	658
Register 17:	EEPROM Size Information (EESIZE), offset 0x000	659
Register 18:	EEPROM Current Block (EEBLOCK), offset 0x004	660
Register 19:	EEPROM Current Offset (EEOFFSET), offset 0x008	661

Register 20:	EEPROM Read-Write (EERDWR), offset 0x010	662
Register 21:	EEPROM Read-Write with Increment (EERDWRINC), offset 0x014	663
Register 22:	EEPROM Done Status (EEDONE), offset 0x018	664
Register 23:	EEPROM Support Control and Status (EESUPP), offset 0x01C	666
Register 24:	EEPROM Unlock (EEUNLOCK), offset 0x020	667
Register 25:	EEPROM Protection (EEPROT), offset 0x030	668
Register 26:	EEPROM Password (EEPASS0), offset 0x034	670
Register 27:	EEPROM Password (EEPASS1), offset 0x038	670
Register 28:	EEPROM Password (EEPASS2), offset 0x03C	670
Register 29:	EEPROM Interrupt (EEINT), offset 0x040	671
Register 30:	EEPROM Block Hide 0 (EEHIDE0), offset 0x050	672
Register 31:	EEPROM Block Hide 1 (EEHIDE1), offset 0x054	673
Register 32:	EEPROM Block Hide 2 (EEHIDE2), offset 0x058	673
Register 33:	EEPROM Debug Mass Erase (EEDBGME), offset 0x080	674
Register 34:	EEPROM Peripheral Properties (EEPROMPP), offset 0xFC0	675
Register 35:	Reset Vector Pointer (RVP), offset 0x0D4	676
Register 36:	Flash Memory Protection Read Enable 0 (FMPRE0), offset 0x200	677
Register 37:	Flash Memory Protection Read Enable 1 (FMPRE1), offset 0x204	677
Register 38:	Flash Memory Protection Read Enable 2 (FMPRE2), offset 0x208	677
Register 39:	Flash Memory Protection Read Enable 3 (FMPRE3), offset 0x20C	677
Register 40:	Flash Memory Protection Read Enable 4 (FMPRE4), offset 0x210	677
Register 41:	Flash Memory Protection Read Enable 5 (FMPRE5), offset 0x214	677
Register 42:	Flash Memory Protection Read Enable 6 (FMPRE6), offset 0x218	677
Register 43:	Flash Memory Protection Read Enable 7 (FMPRE7), offset 0x21C	677
Register 44:	Flash Memory Protection Read Enable 8 (FMPRE8), offset 0x220	677
Register 45:	Flash Memory Protection Read Enable 9 (FMPRE9), offset 0x224	677
Register 46:	Flash Memory Protection Read Enable 10 (FMPRE10), offset 0x228	677
Register 47:	Flash Memory Protection Read Enable 11 (FMPRE11), offset 0x22C	677
Register 48:	Flash Memory Protection Read Enable 12 (FMPRE12), offset 0x230	677
Register 49:	Flash Memory Protection Read Enable 13 (FMPRE13), offset 0x234	677
Register 50:	Flash Memory Protection Read Enable 14 (FMPRE14), offset 0x238	677
Register 51:	Flash Memory Protection Read Enable 15 (FMPRE15), offset 0x23C	677
Register 52:	Flash Memory Protection Program Enable 0 (FMPPE0), offset 0x400	679
Register 53:	Flash Memory Protection Program Enable 1 (FMPPE1), offset 0x404	679
Register 54:	Flash Memory Protection Program Enable 2 (FMPPE2), offset 0x408	679
Register 55:	Flash Memory Protection Program Enable 3 (FMPPE3), offset 0x40C	679
Register 56:	Flash Memory Protection Program Enable 4 (FMPPE4), offset 0x410	679
Register 57:	Flash Memory Protection Program Enable 5 (FMPPE5), offset 0x414	679
Register 58:	Flash Memory Protection Program Enable 6 (FMPPE6), offset 0x418	679
Register 59:	Flash Memory Protection Program Enable 7 (FMPPE7), offset 0x41C	679
Register 60:	Flash Memory Protection Program Enable 8 (FMPPE8), offset 0x420	679
Register 61:	Flash Memory Protection Program Enable 9 (FMPPE9), offset 0x424	679
Register 62:	Flash Memory Protection Program Enable 10 (FMPPE10), offset 0x428	679
Register 63:	Flash Memory Protection Program Enable 11 (FMPPE11), offset 0x42C	679
Register 64:	Flash Memory Protection Program Enable 12 (FMPPE12), offset 0x430	679
Register 65:	Flash Memory Protection Program Enable 13 (FMPPE13), offset 0x434	679
Register 66:	Flash Memory Protection Program Enable 14 (FMPPE14), offset 0x438	679
Register 67:	Flash Memory Protection Program Enable 15 (FMPPE15), offset 0x43C	679

Register 68:	Boot Configuration (BOOTCFG), offset 0x1D0	682
Register 69:	User Register 0 (USER_REG0), offset 0x1E0	685
Register 70:	User Register 1 (USER_REG1), offset 0x1E4	685
Register 71:	User Register 2 (USER_REG2), offset 0x1E8	685
Register 72:	User Register 3 (USER_REG3), offset 0x1EC	685
Micro Direct Memory Access (μDMA)		686
Register 1:	DMA Channel Source Address End Pointer (DMASRCENDP), offset 0x000	711
Register 2:	DMA Channel Destination Address End Pointer (DMADSTENDP), offset 0x004	712
Register 3:	DMA Channel Control Word (DMACHCTL), offset 0x008	713
Register 4:	DMA Status (DMASTAT), offset 0x000	718
Register 5:	DMA Configuration (DMACFG), offset 0x004	720
Register 6:	DMA Channel Control Base Pointer (DMACTLBASE), offset 0x008	721
Register 7:	DMA Alternate Channel Control Base Pointer (DMAALTBASE), offset 0x00C	722
Register 8:	DMA Channel Wait-on-Request Status (DMAWAITSTAT), offset 0x010	723
Register 9:	DMA Channel Software Request (DMASWREQ), offset 0x014	724
Register 10:	DMA Channel Useburst Set (DMAUSEBURSTSET), offset 0x018	725
Register 11:	DMA Channel Useburst Clear (DMAUSEBURSTCLR), offset 0x01C	726
Register 12:	DMA Channel Request Mask Set (DMAREQMASKSET), offset 0x020	727
Register 13:	DMA Channel Request Mask Clear (DMAREQMASKCLR), offset 0x024	728
Register 14:	DMA Channel Enable Set (DMAENASET), offset 0x028	729
Register 15:	DMA Channel Enable Clear (DMAENACL), offset 0x02C	730
Register 16:	DMA Channel Primary Alternate Set (DMAALTSET), offset 0x030	731
Register 17:	DMA Channel Primary Alternate Clear (DMAALTCLR), offset 0x034	732
Register 18:	DMA Channel Priority Set (DMAPRIOSET), offset 0x038	733
Register 19:	DMA Channel Priority Clear (DMAPRIOCLR), offset 0x03C	734
Register 20:	DMA Bus Error Clear (DMAERRCLR), offset 0x04C	735
Register 21:	DMA Channel Assignment (DMACHASGN), offset 0x500	736
Register 22:	DMA Channel Map Select 0 (DMACHMAP0), offset 0x510	737
Register 23:	DMA Channel Map Select 1 (DMACHMAP1), offset 0x514	738
Register 24:	DMA Channel Map Select 2 (DMACHMAP2), offset 0x518	739
Register 25:	DMA Channel Map Select 3 (DMACHMAP3), offset 0x51C	740
Register 26:	DMA Peripheral Identification 0 (DMAPeriphID0), offset 0xFE0	741
Register 27:	DMA Peripheral Identification 1 (DMAPeriphID1), offset 0xFE4	742
Register 28:	DMA Peripheral Identification 2 (DMAPeriphID2), offset 0xFE8	743
Register 29:	DMA Peripheral Identification 3 (DMAPeriphID3), offset 0xFEC	744
Register 30:	DMA Peripheral Identification 4 (DMAPeriphID4), offset 0xFD0	745
Register 31:	DMA PrimeCell Identification 0 (DMAPCellID0), offset 0xFF0	746
Register 32:	DMA PrimeCell Identification 1 (DMAPCellID1), offset 0xFF4	747
Register 33:	DMA PrimeCell Identification 2 (DMAPCellID2), offset 0xFF8	748
Register 34:	DMA PrimeCell Identification 3 (DMAPCellID3), offset 0xFFC	749
General-Purpose Input/Outputs (GPIOs)		750
Register 1:	GPIO Data (GPIODATA), offset 0x000	767
Register 2:	GPIO Direction (GPIODIR), offset 0x400	768
Register 3:	GPIO Interrupt Sense (GPIOIS), offset 0x404	769
Register 4:	GPIO Interrupt Both Edges (GPIOIBE), offset 0x408	770
Register 5:	GPIO Interrupt Event (GPIOIEV), offset 0x40C	771
Register 6:	GPIO Interrupt Mask (GPIOIM), offset 0x410	772
Register 7:	GPIO Raw Interrupt Status (GPIORIS), offset 0x414	773

Register 8:	GPIO Masked Interrupt Status (GPIOMIS), offset 0x418	775
Register 9:	GPIO Interrupt Clear (GPIOICR), offset 0x41C	777
Register 10:	GPIO Alternate Function Select (GPIOAFSEL), offset 0x420	778
Register 11:	GPIO 2-mA Drive Select (GPIODR2R), offset 0x500	780
Register 12:	GPIO 4-mA Drive Select (GPIODR4R), offset 0x504	781
Register 13:	GPIO 8-mA Drive Select (GPIODR8R), offset 0x508	782
Register 14:	GPIO Open Drain Select (GPIOODR), offset 0x50C	783
Register 15:	GPIO Pull-Up Select (GPIOPUR), offset 0x510	784
Register 16:	GPIO Pull-Down Select (GPIOPDR), offset 0x514	786
Register 17:	GPIO Slew Rate Control Select (GPIOSLR), offset 0x518	788
Register 18:	GPIO Digital Enable (GPIODEN), offset 0x51C	789
Register 19:	GPIO Lock (GPIOLOCK), offset 0x520	791
Register 20:	GPIO Commit (GPIOCR), offset 0x524	792
Register 21:	GPIO Analog Mode Select (GPIOAMSEL), offset 0x528	794
Register 22:	GPIO Port Control (GPIOCTL), offset 0x52C	795
Register 23:	GPIO ADC Control (GPIOADCCTL), offset 0x530	797
Register 24:	GPIO DMA Control (GPIODMACTL), offset 0x534	798
Register 25:	GPIO Select Interrupt (GPIOSI), offset 0x538	799
Register 26:	GPIO 12-mA Drive Select (GPIODR12R), offset 0x53C	800
Register 27:	GPIO Wake Pin Enable (GPIOWAKEPEN), offset 0x540	801
Register 28:	GPIO Wake Level (GPIOWAKELVL), offset 0x544	803
Register 29:	GPIO Wake Status (GPIOWAKESTAT), offset 0x548	805
Register 30:	GPIO Peripheral Property (GPIOPP), offset 0xFC0	807
Register 31:	GPIO Peripheral Configuration (GPIOPC), offset 0xFC4	808
Register 32:	GPIO Peripheral Identification 4 (GPIOPeriphID4), offset 0xFD0	811
Register 33:	GPIO Peripheral Identification 5 (GPIOPeriphID5), offset 0xFD4	812
Register 34:	GPIO Peripheral Identification 6 (GPIOPeriphID6), offset 0xFD8	813
Register 35:	GPIO Peripheral Identification 7 (GPIOPeriphID7), offset 0xFDC	814
Register 36:	GPIO Peripheral Identification 0 (GPIOPeriphID0), offset 0xFE0	815
Register 37:	GPIO Peripheral Identification 1 (GPIOPeriphID1), offset 0xFE4	816
Register 38:	GPIO Peripheral Identification 2 (GPIOPeriphID2), offset 0xFE8	817
Register 39:	GPIO Peripheral Identification 3 (GPIOPeriphID3), offset 0xFEC	818
Register 40:	GPIO PrimeCell Identification 0 (GPIOPCellID0), offset 0xFF0	819
Register 41:	GPIO PrimeCell Identification 1 (GPIOPCellID1), offset 0xFF4	820
Register 42:	GPIO PrimeCell Identification 2 (GPIOPCellID2), offset 0xFF8	821
Register 43:	GPIO PrimeCell Identification 3 (GPIOPCellID3), offset 0xFFC	822
External Peripheral Interface (EPI)		823
Register 1:	EPI Configuration (EPICFG), offset 0x000	865
Register 2:	EPI Main Baud Rate (EPIBAUD), offset 0x004	867
Register 3:	EPI Main Baud Rate (EPIBAUD2), offset 0x008	869
Register 4:	EPI SDRAM Configuration (EPISDRAMCFG), offset 0x010	871
Register 5:	EPI Host-Bus 8 Configuration (EPIHB8CFG), offset 0x010	873
Register 6:	EPI Host-Bus 16 Configuration (EPIHB16CFG), offset 0x010	878
Register 7:	EPI General-Purpose Configuration (EPIGPCFG), offset 0x010	884
Register 8:	EPI Host-Bus 8 Configuration 2 (EPIHB8CFG2), offset 0x014	887
Register 9:	EPI Host-Bus 16 Configuration 2 (EPIHB16CFG2), offset 0x014	893
Register 10:	EPI Address Map (EPIADDRMAP), offset 0x01C	900
Register 11:	EPI Read Size 0 (EPIRSIZE0), offset 0x020	903

Register 12:	EPI Read Size 1 (EPIRSIZE1), offset 0x030	903
Register 13:	EPI Read Address 0 (EPIRADDR0), offset 0x024	904
Register 14:	EPI Read Address 1 (EPIRADDR1), offset 0x034	904
Register 15:	EPI Non-Blocking Read Data 0 (EPIRPSTD0), offset 0x028	905
Register 16:	EPI Non-Blocking Read Data 1 (EPIRPSTD1), offset 0x038	905
Register 17:	EPI Status (EPISTAT), offset 0x060	907
Register 18:	EPI Read FIFO Count (EPIRFIFOCNT), offset 0x06C	909
Register 19:	EPI Read FIFO (EPIREADFIFO0), offset 0x070	910
Register 20:	EPI Read FIFO Alias 1 (EPIREADFIFO1), offset 0x074	910
Register 21:	EPI Read FIFO Alias 2 (EPIREADFIFO2), offset 0x078	910
Register 22:	EPI Read FIFO Alias 3 (EPIREADFIFO3), offset 0x07C	910
Register 23:	EPI Read FIFO Alias 4 (EPIREADFIFO4), offset 0x080	910
Register 24:	EPI Read FIFO Alias 5 (EPIREADFIFO5), offset 0x084	910
Register 25:	EPI Read FIFO Alias 6 (EPIREADFIFO6), offset 0x088	910
Register 26:	EPI Read FIFO Alias 7 (EPIREADFIFO7), offset 0x08C	910
Register 27:	EPI FIFO Level Selects (EPIFIFOLVL), offset 0x200	911
Register 28:	EPI Write FIFO Count (EPIWFIFOCNT), offset 0x204	913
Register 29:	EPI DMA Transmit Count (EPIDMATXCNT), offset 0x208	914
Register 30:	EPI Interrupt Mask (EPIIM), offset 0x210	915
Register 31:	EPI Raw Interrupt Status (EPIRIS), offset 0x214	917
Register 32:	EPI Masked Interrupt Status (EPIMIS), offset 0x218	919
Register 33:	EPI Error and Interrupt Status and Clear (EPIEISC), offset 0x21C	921
Register 34:	EPI Host-Bus 8 Configuration 3 (EPIHB8CFG3), offset 0x308	923
Register 35:	EPI Host-Bus 16 Configuration 3 (EPIHB16CFG3), offset 0x308	926
Register 36:	EPI Host-Bus 8 Configuration 4 (EPIHB8CFG4), offset 0x30C	930
Register 37:	EPI Host-Bus 16 Configuration 4 (EPIHB16CFG4), offset 0x30C	933
Register 38:	EPI Host-Bus 8 Timing Extension (EPIHB8TIME), offset 0x310	937
Register 39:	EPI Host-Bus 16 Timing Extension (EPIHB16TIME), offset 0x310	939
Register 40:	EPI Host-Bus 8 Timing Extension (EPIHB8TIME2), offset 0x314	941
Register 41:	EPI Host-Bus 16 Timing Extension (EPIHB16TIME2), offset 0x314	943
Register 42:	EPI Host-Bus 8 Timing Extension (EPIHB8TIME3), offset 0x318	945
Register 43:	EPI Host-Bus 16 Timing Extension (EPIHB16TIME3), offset 0x318	947
Register 44:	EPI Host-Bus 8 Timing Extension (EPIHB8TIME4), offset 0x31C	949
Register 45:	EPI Host-Bus 16 Timing Extension (EPIHB16TIME4), offset 0x31C	951
Register 46:	EPI Host-Bus PSRAM (EPIHBPSRAM), offset 0x360	953
Cyclical Redundancy Check (CRC)		954
Register 1:	CRC Control (CRCCTRL), offset 0x400	958
Register 2:	CRC SEED/Context (CRCSEED), offset 0x410	960
Register 3:	CRC Data Input (CRCDIN), offset 0x414	961
Register 4:	CRC Post Processing Result (CRCRSLTPP), offset 0x418	962
Advance Encryption Standard Accelerator (AES)		963
Register 1:	AES Key 2_6 (AES_KEY2_6), offset 0x000	987
Register 2:	AES Key 2_7 (AES_KEY2_7), offset 0x004	987
Register 3:	AES Key 2_4 (AES_KEY2_4), offset 0x008	987
Register 4:	AES Key 2_5 (AES_KEY2_5), offset 0x00C	987
Register 5:	AES Key 2_2 (AES_KEY2_2), offset 0x010	987
Register 6:	AES Key 2_3 (AES_KEY2_3), offset 0x014	987
Register 7:	AES Key 2_0 (AES_KEY2_0), offset 0x018	987

Register 8:	AES Key 2_1 (AES_KEY2_1), offset 0x01C	987
Register 9:	AES Key 1_6 (AES_KEY1_6), offset 0x020	987
Register 10:	AES Key 1_7 (AES_KEY1_7), offset 0x024	987
Register 11:	AES Key 1_4 (AES_KEY1_4), offset 0x028	987
Register 12:	AES Key 1_5 (AES_KEY1_5), offset 0x02C	987
Register 13:	AES Key 1_2 (AES_KEY1_2), offset 0x030	987
Register 14:	AES Key 1_3 (AES_KEY1_3), offset 0x034	987
Register 15:	AES Key 1_0 (AES_KEY1_0), offset 0x038	987
Register 16:	AES Key 1_1 (AES_KEY1_1), offset 0x03C	987
Register 17:	AES Initialization Vector Input 0 (AES_IV_IN_0), offset 0x040	989
Register 18:	AES Initialization Vector Input 1 (AES_IV_IN_1), offset 0x044	989
Register 19:	AES Initialization Vector Input 2 (AES_IV_IN_2), offset 0x048	989
Register 20:	AES Initialization Vector Input 3 (AES_IV_IN_3), offset 0x04C	989
Register 21:	AES Control (AES_CTRL), offset 0x050	990
Register 22:	AES Crypto Data Length 0 (AES_C_LENGTH_0), offset 0x054	995
Register 23:	AES Crypto Data Length 1 (AES_C_LENGTH_1), offset 0x058	995
Register 24:	AES Authentication Data Length (AES_AUTH_LENGTH), offset 0x05C	996
Register 25:	AES Data RW Plaintext/Ciphertext 0 (AES_DATA_IN_0), offset 0x060	997
Register 26:	AES Data RW Plaintext/Ciphertext 1 (AES_DATA_IN_1), offset 0x064	997
Register 27:	AES Data RW Plaintext/Ciphertext 2 (AES_DATA_IN_2), offset 0x068	997
Register 28:	AES Data RW Plaintext/Ciphertext 3 (AES_DATA_IN_3), offset 0x06C	997
Register 29:	AES Hash Tag Out 0 (AES_TAG_OUT_0), offset 0x070	998
Register 30:	AES Hash Tag Out 1 (AES_TAG_OUT_1), offset 0x074	998
Register 31:	AES Hash Tag Out 2 (AES_TAG_OUT_2), offset 0x078	998
Register 32:	AES Hash Tag Out 3 (AES_TAG_OUT_3), offset 0x07C	998
Register 33:	AES IP Revision Identifier (AES_REVISION), offset 0x080	999
Register 34:	AES System Configuration (AES_SYSCONFIG), offset 0x084	1000
Register 35:	AES System Status (AES_SYSSTATUS), offset 0x088	1003
Register 36:	AES Interrupt Status (AES_IRQSTATUS), offset 0x08C	1004
Register 37:	AES Interrupt Enable (AES_IRQENABLE), offset 0x090	1006
Register 38:	AES Dirty Bits (AES_DIRTYBITS), offset 0x094	1008
Register 39:	AES DMA Interrupt Mask (AES_DMAIM), offset 0x020	1009
Register 40:	AES DMA Raw Interrupt Status (AES_DMARIS), offset 0x024	1011
Register 41:	AES DMA Masked Interrupt Status (AES_DMAMIS), offset 0x028	1013
Register 42:	AES DMA Interrupt Clear (AES_DMAIC), offset 0x02C	1014
Data Encryption Standard Accelerator (DES)		1015
Register 1:	DES Key 3 LSW for 192-Bit Key (DES_KEY3_L), offset 0x000	1026
Register 2:	DES Key 3 MSW for 192-Bit Key (DES_KEY3_H), offset 0x004	1026
Register 3:	DES Key 2 LSW for 128-Bit Key (DES_KEY2_L), offset 0x008	1026
Register 4:	DES Key 2 MSW for 128-Bit Key (DES_KEY2_H), offset 0x00C	1026
Register 5:	DES Key 1 LSW for 64-Bit Key (DES_KEY1_L), offset 0x010	1026
Register 6:	DES Key 1 MSW for 64-Bit Key (DES_KEY1_H), offset 0x014	1026
Register 7:	DES Initialization Vector (DES_IV_L), offset 0x018	1027
Register 8:	DES Initialization Vector (DES_IV_H), offset 0x01C	1028
Register 9:	DES Control (DES_CTRL), offset 0x020	1029
Register 10:	DES Cryptographic Data Length (DES_LENGTH), offset 0x024	1030
Register 11:	DES LSW Data RW (DES_DATA_L), offset 0x028	1031
Register 12:	DES MSW Data RW (DES_DATA_H), offset 0x02C	1032

Register 13:	DES Revision Number (DES_REVISION), offset 0x030	1033
Register 14:	DES System Configuration (DES_SYSCONFIG), offset 0x034	1034
Register 15:	DES System Status (DES_SYSSTATUS), offset 0x038	1036
Register 16:	DES Interrupt Status (DES_IRQSTATUS), offset 0x03C	1037
Register 17:	DES Interrupt Enable (DES_IRQENABLE), offset 0x040	1038
Register 18:	DES Dirty Bits (DES_DIRTYBITS), offset 0x044	1039
Register 19:	DES DMA Interrupt Mask (DES_DMAIM), offset 0x030	1040
Register 20:	DES DMA Raw Interrupt Status (DES_DMARIS), offset 0x034	1041
Register 21:	DES DMA Masked Interrupt Status (DES_DMAMIS), offset 0x038	1042
Register 22:	DES DMA Interrupt Clear (DES_DMAIC), offset 0x03C	1043
SHA/MD5 Accelerator	1044	
Register 1:	SHA Outer Digest A (SHA_ODIGEST_A), offset 0x000	1062
Register 2:	SHA Outer Digest B (SHA_ODIGEST_B), offset 0x004	1062
Register 3:	SHA Outer Digest C (SHA_ODIGEST_C), offset 0x008	1062
Register 4:	SHA Outer Digest D (SHA_ODIGEST_D), offset 0x00C	1062
Register 5:	SHA Outer Digest E (SHA_ODIGEST_E), offset 0x010	1062
Register 6:	SHA Outer Digest F (SHA_ODIGEST_F), offset 0x014	1062
Register 7:	SHA Outer Digest G (SHA_ODIGEST_G), offset 0x018	1062
Register 8:	SHA Outer Digest H (SHA_ODIGEST_H), offset 0x01C	1062
Register 9:	SHA Inner Digest A (SHA_IDIGEST_A), offset 0x020	1062
Register 10:	SHA Inner Digest B (SHA_IDIGEST_B), offset 0x024	1062
Register 11:	SHA Inner Digest C (SHA_IDIGEST_C), offset 0x028	1062
Register 12:	SHA Inner Digest D (SHA_IDIGEST_D), offset 0x02C	1062
Register 13:	SHA Inner Digest E (SHA_IDIGEST_E), offset 0x030	1062
Register 14:	SHA Inner Digest F (SHA_IDIGEST_F), offset 0x034	1062
Register 15:	SHA Inner Digest G (SHA_IDIGEST_G), offset 0x038	1062
Register 16:	SHA Inner Digest H (SHA_IDIGEST_H), offset 0x03C	1062
Register 17:	SHA Digest Count (SHA_DIGEST_COUNT), offset 0x040	1063
Register 18:	SHA Mode (SHA_MODE), offset 0x044	1064
Register 19:	SHA Length (SHA_LENGTH), offset 0x048	1066
Register 20:	SHA Data 0 Input (SHA_DATA_0_IN), offset 0x080	1067
Register 21:	SHA Data 1 Input (SHA_DATA_1_IN), offset 0x084	1067
Register 22:	SHA Data 2 Input (SHA_DATA_2_IN), offset 0x088	1067
Register 23:	SHA Data 3 Input (SHA_DATA_3_IN), offset 0x08C	1067
Register 24:	SHA Data 4 Input (SHA_DATA_4_IN), offset 0x090	1067
Register 25:	SHA Data 5 Input (SHA_DATA_5_IN), offset 0x094	1067
Register 26:	SHA Data 6 Input (SHA_DATA_6_IN), offset 0x098	1067
Register 27:	SHA Data 7 Input (SHA_DATA_7_IN), offset 0x09C	1067
Register 28:	SHA Data 8 Input (SHA_DATA_8_IN), offset 0x0A0	1067
Register 29:	SHA Data 9 Input (SHA_DATA_9_IN), offset 0x0A4	1067
Register 30:	SHA Data 10 Input (SHA_DATA_10_IN), offset 0x0A8	1067
Register 31:	SHA Data 11 Input (SHA_DATA_11_IN), offset 0x0AC	1067
Register 32:	SHA Data 12 Input (SHA_DATA_12_IN), offset 0x0B0	1067
Register 33:	SHA Data 13 Input (SHA_DATA_13_IN), offset 0x0B4	1067
Register 34:	SHA Data 14 Input (SHA_DATA_14_IN), offset 0x0B8	1067
Register 35:	SHA Data 15 Input (SHA_DATA_15_IN), offset 0x0BC	1067
Register 36:	SHA Revision (SHA_REVISION), offset 0x100	1068
Register 37:	SHA System Configuration (SHA_SYSCONFIG), offset 0x110	1069

Register 38:	SHA System Status (SHA_SYSSTATUS), offset 0x114	1071
Register 39:	SHA Interrupt Status (SHA_IRQSTATUS), offset 0x118	1072
Register 40:	SHA Interrupt Enable (SHA_IRQENABLE), offset 0x11C	1073
Register 41:	SHA DMA Interrupt Mask (SHA_DMAIM), offset 0x010	1075
Register 42:	SHA DMA Raw Interrupt Status (SHA_DMARIS), offset 0x014	1076
Register 43:	SHA DMA Masked Interrupt Status (SHA_DMAMIS), offset 0x018	1077
Register 44:	SHA DMA Interrupt Clear (SHA_DMAIC), offset 0x01C	1078
General-Purpose Timers		1079
Register 1:	GPTM Configuration (GPTMCFG), offset 0x000	1100
Register 2:	GPTM Timer A Mode (GPTMTAMR), offset 0x004	1101
Register 3:	GPTM Timer B Mode (GPTMTBMR), offset 0x008	1106
Register 4:	GPTM Control (GPTMCTL), offset 0x00C	1110
Register 5:	GPTM Synchronize (GPTMSYNC), offset 0x010	1114
Register 6:	GPTM Interrupt Mask (GPTMIMR), offset 0x018	1117
Register 7:	GPTM Raw Interrupt Status (GPTMRIS), offset 0x01C	1120
Register 8:	GPTM Masked Interrupt Status (GPTMMIS), offset 0x020	1123
Register 9:	GPTM Interrupt Clear (GPTMICR), offset 0x024	1126
Register 10:	GPTM Timer A Interval Load (GPTMTAILR), offset 0x028	1128
Register 11:	GPTM Timer B Interval Load (GPTMTBILR), offset 0x02C	1129
Register 12:	GPTM Timer A Match (GPTMTAMATCHR), offset 0x030	1130
Register 13:	GPTM Timer B Match (GPTMTBMATCHR), offset 0x034	1131
Register 14:	GPTM Timer A Prescale (GPTMTAPR), offset 0x038	1132
Register 15:	GPTM Timer B Prescale (GPTMTBPR), offset 0x03C	1133
Register 16:	GPTM TimerA Prescale Match (GPTMTAPMR), offset 0x040	1134
Register 17:	GPTM TimerB Prescale Match (GPTMTBPMR), offset 0x044	1135
Register 18:	GPTM Timer A (GPTMTAR), offset 0x048	1136
Register 19:	GPTM Timer B (GPTMTBR), offset 0x04C	1137
Register 20:	GPTM Timer A Value (GPTMTAV), offset 0x050	1138
Register 21:	GPTM Timer B Value (GPTMTBV), offset 0x054	1139
Register 22:	GPTM RTC Predivide (GPTMRTCPD), offset 0x058	1140
Register 23:	GPTM Timer A Prescale Snapshot (GPTMTAPS), offset 0x05C	1141
Register 24:	GPTM Timer B Prescale Snapshot (GPTMTBPS), offset 0x060	1142
Register 25:	GPTM DMA Event (GPTMDMAEV), offset 0x06C	1143
Register 26:	GPTM ADC Event (GPTMADCEV), offset 0x070	1146
Register 27:	GPTM Peripheral Properties (GPTMPP), offset 0xFC0	1149
Register 28:	GPTM Clock Configuration (GPTMCC), offset 0xFC8	1151
Watchdog Timers		1152
Register 1:	Watchdog Load (WDTLOAD), offset 0x000	1156
Register 2:	Watchdog Value (WDTVALUE), offset 0x004	1157
Register 3:	Watchdog Control (WDTCTL), offset 0x008	1158
Register 4:	Watchdog Interrupt Clear (WDTICR), offset 0x00C	1160
Register 5:	Watchdog Raw Interrupt Status (WDTRIS), offset 0x010	1161
Register 6:	Watchdog Masked Interrupt Status (WDTMIS), offset 0x014	1162
Register 7:	Watchdog Test (WDTTEST), offset 0x418	1163
Register 8:	Watchdog Lock (WDTLOCK), offset 0xC00	1164
Register 9:	Watchdog Peripheral Identification 4 (WDTPeriphID4), offset 0xFD0	1165
Register 10:	Watchdog Peripheral Identification 5 (WDTPeriphID5), offset 0xFD4	1166
Register 11:	Watchdog Peripheral Identification 6 (WDTPeriphID6), offset 0xFD8	1167

Register 12:	Watchdog Peripheral Identification 7 (WDTPeriphID7), offset 0xFDC	1168
Register 13:	Watchdog Peripheral Identification 0 (WDTPeriphID0), offset 0xFE0	1169
Register 14:	Watchdog Peripheral Identification 1 (WDTPeriphID1), offset 0xFE4	1170
Register 15:	Watchdog Peripheral Identification 2 (WDTPeriphID2), offset 0xFE8	1171
Register 16:	Watchdog Peripheral Identification 3 (WDTPeriphID3), offset 0xFEC	1172
Register 17:	Watchdog PrimeCell Identification 0 (WDTPCellID0), offset 0xFF0	1173
Register 18:	Watchdog PrimeCell Identification 1 (WDTPCellID1), offset 0xFF4	1174
Register 19:	Watchdog PrimeCell Identification 2 (WDTPCellID2), offset 0xFF8	1175
Register 20:	Watchdog PrimeCell Identification 3 (WDTPCellID3), offset 0xFFC	1176
Analog-to-Digital Converter (ADC)		1177
Register 1:	ADC Active Sample Sequencer (ADCACTSS), offset 0x000	1201
Register 2:	ADC Raw Interrupt Status (ADCRIS), offset 0x004	1203
Register 3:	ADC Interrupt Mask (ADCIM), offset 0x008	1206
Register 4:	ADC Interrupt Status and Clear (ADCISC), offset 0x00C	1209
Register 5:	ADC Overflow Status (ADCOSTAT), offset 0x010	1213
Register 6:	ADC Event Multiplexer Select (ADCEMUX), offset 0x014	1215
Register 7:	ADC Underflow Status (ADCUSTAT), offset 0x018	1220
Register 8:	ADC Trigger Source Select (ADCTSSEL), offset 0x01C	1221
Register 9:	ADC Sample Sequencer Priority (ADCSSPRI), offset 0x020	1223
Register 10:	ADC Sample Phase Control (ADCSPC), offset 0x024	1225
Register 11:	ADC Processor Sample Sequence Initiate (ADCPSSI), offset 0x028	1227
Register 12:	ADC Sample Averaging Control (ADCSAC), offset 0x030	1229
Register 13:	ADC Digital Comparator Interrupt Status and Clear (ADCDCISC), offset 0x034	1230
Register 14:	ADC Control (ADCCTL), offset 0x038	1232
Register 15:	ADC Sample Sequence Input Multiplexer Select 0 (ADCSSMUX0), offset 0x040	1233
Register 16:	ADC Sample Sequence Control 0 (ADCSSCTL0), offset 0x044	1235
Register 17:	ADC Sample Sequence Result FIFO 0 (ADCSSFIFO0), offset 0x048	1242
Register 18:	ADC Sample Sequence Result FIFO 1 (ADCSSFIFO1), offset 0x068	1242
Register 19:	ADC Sample Sequence Result FIFO 2 (ADCSSFIFO2), offset 0x088	1242
Register 20:	ADC Sample Sequence Result FIFO 3 (ADCSSFIFO3), offset 0x0A8	1242
Register 21:	ADC Sample Sequence FIFO 0 Status (ADCSSFSTAT0), offset 0x04C	1243
Register 22:	ADC Sample Sequence FIFO 1 Status (ADCSSFSTAT1), offset 0x06C	1243
Register 23:	ADC Sample Sequence FIFO 2 Status (ADCSSFSTAT2), offset 0x08C	1243
Register 24:	ADC Sample Sequence FIFO 3 Status (ADCSSFSTAT3), offset 0x0AC	1243
Register 25:	ADC Sample Sequence 0 Operation (ADCSSOP0), offset 0x050	1245
Register 26:	ADC Sample Sequence 0 Digital Comparator Select (ADCSSDC0), offset 0x054	1247
Register 27:	ADC Sample Sequence Extended Input Multiplexer Select 0 (ADCSSEMUX0), offset 0x058	1249
Register 28:	ADC Sample Sequence 0 Sample and Hold Time (ADCSSSTSH0), offset 0x05C	1251
Register 29:	ADC Sample Sequence Input Multiplexer Select 1 (ADCSSMUX1), offset 0x060	1253
Register 30:	ADC Sample Sequence Input Multiplexer Select 2 (ADCSSMUX2), offset 0x080	1253
Register 31:	ADC Sample Sequence Control 1 (ADCSSCTL1), offset 0x064	1254
Register 32:	ADC Sample Sequence Control 2 (ADCSSCTL2), offset 0x084	1254
Register 33:	ADC Sample Sequence 1 Operation (ADCSSOP1), offset 0x070	1258
Register 34:	ADC Sample Sequence 2 Operation (ADCSSOP2), offset 0x090	1258
Register 35:	ADC Sample Sequence 1 Digital Comparator Select (ADCSSDC1), offset 0x074	1259
Register 36:	ADC Sample Sequence 2 Digital Comparator Select (ADCSSDC2), offset 0x094	1259

Register 37:	ADC Sample Sequence Extended Input Multiplexer Select 1 (ADCSEMUX1), offset 0x078	1261
Register 38:	ADC Sample Sequence Extended Input Multiplexer Select 2 (ADCSEMUX2), offset 0x098	1261
Register 39:	ADC Sample Sequence 1 Sample and Hold Time (ADCSSTSH1), offset 0x07C	1263
Register 40:	ADC Sample Sequence 2 Sample and Hold Time (ADCSSTSH2), offset 0x09C	1263
Register 41:	ADC Sample Sequence Input Multiplexer Select 3 (ADCSSMUX3), offset 0x0A0	1265
Register 42:	ADC Sample Sequence Control 3 (ADCSSCTL3), offset 0x0A4	1266
Register 43:	ADC Sample Sequence 3 Operation (ADCSSOP3), offset 0x0B0	1268
Register 44:	ADC Sample Sequence 3 Digital Comparator Select (ADCSSDC3), offset 0x0B4	1269
Register 45:	ADC Sample Sequence Extended Input Multiplexer Select 3 (ADCSEMUX3), offset 0x0B8	1270
Register 46:	ADC Sample Sequence 3 Sample and Hold Time (ADCSSTSH3), offset 0x0BC	1271
Register 47:	ADC Digital Comparator Reset Initial Conditions (ADCDCRIC), offset 0xD00	1272
Register 48:	ADC Digital Comparator Control 0 (ADCDCCTL0), offset 0xE00	1277
Register 49:	ADC Digital Comparator Control 1 (ADCDCCTL1), offset 0xE04	1277
Register 50:	ADC Digital Comparator Control 2 (ADCDCCTL2), offset 0xE08	1277
Register 51:	ADC Digital Comparator Control 3 (ADCDCCTL3), offset 0xE0C	1277
Register 52:	ADC Digital Comparator Control 4 (ADCDCCTL4), offset 0xE10	1277
Register 53:	ADC Digital Comparator Control 5 (ADCDCCTL5), offset 0xE14	1277
Register 54:	ADC Digital Comparator Control 6 (ADCDCCTL6), offset 0xE18	1277
Register 55:	ADC Digital Comparator Control 7 (ADCDCCTL7), offset 0xE1C	1277
Register 56:	ADC Digital Comparator Range 0 (ADCDCCMP0), offset 0xE40	1280
Register 57:	ADC Digital Comparator Range 1 (ADCDCCMP1), offset 0xE44	1280
Register 58:	ADC Digital Comparator Range 2 (ADCDCCMP2), offset 0xE48	1280
Register 59:	ADC Digital Comparator Range 3 (ADCDCCMP3), offset 0xE4C	1280
Register 60:	ADC Digital Comparator Range 4 (ADCDCCMP4), offset 0xE50	1280
Register 61:	ADC Digital Comparator Range 5 (ADCDCCMP5), offset 0xE54	1280
Register 62:	ADC Digital Comparator Range 6 (ADCDCCMP6), offset 0xE58	1280
Register 63:	ADC Digital Comparator Range 7 (ADCDCCMP7), offset 0xE5C	1280
Register 64:	ADC Peripheral Properties (ADCPP), offset 0xFC0	1281
Register 65:	ADC Peripheral Configuration (ADPC), offset 0xFC4	1283
Register 66:	ADC Clock Configuration (ADCCC), offset 0xFC8	1284
Universal Asynchronous Receivers/Transmitters (UARTs)		1285
Register 1:	UART Data (UARTDR), offset 0x000	1299
Register 2:	UART Receive Status/Error Clear (UARTRSR/UARTECR), offset 0x004	1301
Register 3:	UART Flag (UARTFR), offset 0x018	1304
Register 4:	UART IrDA Low-Power Register (UARTILPR), offset 0x020	1307
Register 5:	UART Integer Baud-Rate Divisor (UARTIBRD), offset 0x024	1308
Register 6:	UART Fractional Baud-Rate Divisor (UARTFBRD), offset 0x028	1309
Register 7:	UART Line Control (UARTLCRH), offset 0x02C	1310
Register 8:	UART Control (UARTCTL), offset 0x030	1312
Register 9:	UART Interrupt FIFO Level Select (UARTIFLS), offset 0x034	1316
Register 10:	UART Interrupt Mask (UARTIM), offset 0x038	1318
Register 11:	UART Raw Interrupt Status (UARTRIS), offset 0x03C	1322
Register 12:	UART Masked Interrupt Status (UARTMIS), offset 0x040	1326
Register 13:	UART Interrupt Clear (UARTICR), offset 0x044	1330
Register 14:	UART DMA Control (UARTDMACTL), offset 0x048	1332

Register 15:	UART 9-Bit Self Address (UART9BITADDR), offset 0x0A4	1333
Register 16:	UART 9-Bit Self Address Mask (UART9BITAMASK), offset 0x0A8	1334
Register 17:	UART Peripheral Properties (UARTPP), offset 0xFC0	1335
Register 18:	UART Clock Configuration (UARTCC), offset 0xFC8	1337
Register 19:	UART Peripheral Identification 4 (UARTPeriphID4), offset 0xFD0	1338
Register 20:	UART Peripheral Identification 5 (UARTPeriphID5), offset 0xFD4	1339
Register 21:	UART Peripheral Identification 6 (UARTPeriphID6), offset 0xFD8	1340
Register 22:	UART Peripheral Identification 7 (UARTPeriphID7), offset 0xFDC	1341
Register 23:	UART Peripheral Identification 0 (UARTPeriphID0), offset 0xFE0	1342
Register 24:	UART Peripheral Identification 1 (UARTPeriphID1), offset 0xFE4	1343
Register 25:	UART Peripheral Identification 2 (UARTPeriphID2), offset 0xFE8	1344
Register 26:	UART Peripheral Identification 3 (UARTPeriphID3), offset 0xFEC	1345
Register 27:	UART PrimeCell Identification 0 (UARTPCellID0), offset 0xFF0	1346
Register 28:	UART PrimeCell Identification 1 (UARTPCellID1), offset 0xFF4	1347
Register 29:	UART PrimeCell Identification 2 (UARTPCellID2), offset 0xFF8	1348
Register 30:	UART PrimeCell Identification 3 (UARTPCellID3), offset 0xFFC	1349
Quad Synchronous Serial Interface (QSSI)		1350
Register 1:	QSSI Control 0 (SSICR0), offset 0x000	1369
Register 2:	QSSI Control 1 (SSICR1), offset 0x004	1371
Register 3:	QSSI Data (SSIDR), offset 0x008	1373
Register 4:	QSSI Status (SSISR), offset 0x00C	1374
Register 5:	QSSI Clock Prescale (SSICPSR), offset 0x010	1376
Register 6:	QSSI Interrupt Mask (SSIIM), offset 0x014	1377
Register 7:	QSSI Raw Interrupt Status (SSIRIS), offset 0x018	1379
Register 8:	QSSI Masked Interrupt Status (SSIMIS), offset 0x01C	1381
Register 9:	QSSI Interrupt Clear (SSIICR), offset 0x020	1383
Register 10:	QSSI DMA Control (SSIDMACTL), offset 0x024	1384
Register 11:	QSSI Peripheral Properties (SSIPP), offset 0xFC0	1385
Register 12:	QSSI Clock Configuration (SSICC), offset 0xFC8	1386
Register 13:	QSSI Peripheral Identification 4 (SSIPeriphID4), offset 0xFD0	1387
Register 14:	QSSI Peripheral Identification 5 (SSIPeriphID5), offset 0xFD4	1388
Register 15:	QSSI Peripheral Identification 6 (SSIPeriphID6), offset 0xFD8	1389
Register 16:	QSSI Peripheral Identification 7 (SSIPeriphID7), offset 0xFDC	1390
Register 17:	QSSI Peripheral Identification 0 (SSIPeriphID0), offset 0xFE0	1391
Register 18:	QSSI Peripheral Identification 1 (SSIPeriphID1), offset 0xFE4	1392
Register 19:	QSSI Peripheral Identification 2 (SSIPeriphID2), offset 0xFE8	1393
Register 20:	QSSI Peripheral Identification 3 (SSIPeriphID3), offset 0xFEC	1394
Register 21:	QSSI PrimeCell Identification 0 (SSIPCellID0), offset 0xFF0	1395
Register 22:	QSSI PrimeCell Identification 1 (SSIPCellID1), offset 0xFF4	1396
Register 23:	QSSI PrimeCell Identification 2 (SSIPCellID2), offset 0xFF8	1397
Register 24:	QSSI PrimeCell Identification 3 (SSIPCellID3), offset 0xFFC	1398
Inter-Integrated Circuit (I²C) Interface		1399
Register 1:	I ² C Master Slave Address (I2CMSA), offset 0x000	1426
Register 2:	I ² C Master Control/Status (I2CMCS), offset 0x004	1427
Register 3:	I ² C Master Data (I2CMDR), offset 0x008	1436
Register 4:	I ² C Master Timer Period (I2CMTPR), offset 0x00C	1437
Register 5:	I ² C Master Interrupt Mask (I2CMIMR), offset 0x010	1439
Register 6:	I ² C Master Raw Interrupt Status (I2CMRIS), offset 0x014	1442

Register 7:	I ² C Master Masked Interrupt Status (I2CMMIS), offset 0x018	1445
Register 8:	I ² C Master Interrupt Clear (I2CMICR), offset 0x01C	1448
Register 9:	I ² C Master Configuration (I2CMCR), offset 0x020	1450
Register 10:	I ² C Master Clock Low Timeout Count (I2CMCLKOCNT), offset 0x024	1451
Register 11:	I ² C Master Bus Monitor (I2CMBMON), offset 0x02C	1452
Register 12:	I ² C Master Burst Length (I2CMBLEN), offset 0x030	1453
Register 13:	I ² C Master Burst Count (I2CMBCNT), offset 0x034	1454
Register 14:	I ² C Slave Own Address (I2CSOAR), offset 0x800	1455
Register 15:	I ² C Slave Control/Status (I2CSCSR), offset 0x804	1456
Register 16:	I ² C Slave Data (I2CSDR), offset 0x808	1459
Register 17:	I ² C Slave Interrupt Mask (I2CSIMR), offset 0x80C	1460
Register 18:	I ² C Slave Raw Interrupt Status (I2CSRIS), offset 0x810	1462
Register 19:	I ² C Slave Masked Interrupt Status (I2CSMIS), offset 0x814	1465
Register 20:	I ² C Slave Interrupt Clear (I2CSICR), offset 0x818	1468
Register 21:	I ² C Slave Own Address 2 (I2CSOAR2), offset 0x81C	1470
Register 22:	I ² C Slave ACK Control (I2CSACKCTL), offset 0x820	1471
Register 23:	I ² C FIFO Data (I2CFIFODATA), offset 0xF00	1472
Register 24:	I ² C FIFO Control (I2CFIFOCTL), offset 0xF04	1474
Register 25:	I ² C FIFO Status (I2CFIFOSTATUS), offset 0xF08	1476
Register 26:	I ² C Peripheral Properties (I2CPP), offset 0xFC0	1478
Register 27:	I ² C Peripheral Configuration (I2CPC), offset 0xFC4	1479
Controller Area Network (CAN) Module		1480
Register 1:	CAN Control (CANCTL), offset 0x000	1502
Register 2:	CAN Status (CANSTS), offset 0x004	1504
Register 3:	CAN Error Counter (CANERR), offset 0x008	1507
Register 4:	CAN Bit Timing (CANBIT), offset 0x00C	1508
Register 5:	CAN Interrupt (CANINT), offset 0x010	1509
Register 6:	CAN Test (CANTST), offset 0x014	1510
Register 7:	CAN Baud Rate Prescaler Extension (CANBRPE), offset 0x018	1512
Register 8:	CAN IF1 Command Request (CANIF1CRQ), offset 0x020	1513
Register 9:	CAN IF2 Command Request (CANIF2CRQ), offset 0x080	1513
Register 10:	CAN IF1 Command Mask (CANIF1CMSK), offset 0x024	1514
Register 11:	CAN IF2 Command Mask (CANIF2CMSK), offset 0x084	1514
Register 12:	CAN IF1 Mask 1 (CANIF1MSK1), offset 0x028	1517
Register 13:	CAN IF2 Mask 1 (CANIF2MSK1), offset 0x088	1517
Register 14:	CAN IF1 Mask 2 (CANIF1MSK2), offset 0x02C	1518
Register 15:	CAN IF2 Mask 2 (CANIF2MSK2), offset 0x08C	1518
Register 16:	CAN IF1 Arbitration 1 (CANIF1ARB1), offset 0x030	1520
Register 17:	CAN IF2 Arbitration 1 (CANIF2ARB1), offset 0x090	1520
Register 18:	CAN IF1 Arbitration 2 (CANIF1ARB2), offset 0x034	1521
Register 19:	CAN IF2 Arbitration 2 (CANIF2ARB2), offset 0x094	1521
Register 20:	CAN IF1 Message Control (CANIF1MCTL), offset 0x038	1523
Register 21:	CAN IF2 Message Control (CANIF2MCTL), offset 0x098	1523
Register 22:	CAN IF1 Data A1 (CANIF1DA1), offset 0x03C	1526
Register 23:	CAN IF1 Data A2 (CANIF1DA2), offset 0x040	1526
Register 24:	CAN IF1 Data B1 (CANIF1DB1), offset 0x044	1526
Register 25:	CAN IF1 Data B2 (CANIF1DB2), offset 0x048	1526

Register 26:	CAN IF2 Data A1 (CANIF2DA1), offset 0x09C	1526
Register 27:	CAN IF2 Data A2 (CANIF2DA2), offset 0x0A0	1526
Register 28:	CAN IF2 Data B1 (CANIF2DB1), offset 0x0A4	1526
Register 29:	CAN IF2 Data B2 (CANIF2DB2), offset 0x0A8	1526
Register 30:	CAN Transmission Request 1 (CANTXRQ1), offset 0x100	1527
Register 31:	CAN Transmission Request 2 (CANTXRQ2), offset 0x104	1527
Register 32:	CAN New Data 1 (CANNWDA1), offset 0x120	1528
Register 33:	CAN New Data 2 (CANNWDA2), offset 0x124	1528
Register 34:	CAN Message 1 Interrupt Pending (CANMSG1INT), offset 0x140	1529
Register 35:	CAN Message 2 Interrupt Pending (CANMSG2INT), offset 0x144	1529
Register 36:	CAN Message 1 Valid (CANMSG1VAL), offset 0x160	1530
Register 37:	CAN Message 2 Valid (CANMSG2VAL), offset 0x164	1530
Ethernet Controller		1531
Register 1:	Ethernet MAC Configuration (EMACCFG), offset 0x000	1595
Register 2:	Ethernet MAC Frame Filter (EMACFRAMEFLTR), offset 0x004	1602
Register 3:	Ethernet MAC Hash Table High (EMACHASHTBLH), offset 0x008	1606
Register 4:	Ethernet MAC Hash Table Low (EMACHASHTBLL), offset 0x00C	1607
Register 5:	Ethernet MAC MII Address (EMACMIIADDR), offset 0x010	1608
Register 6:	Ethernet MAC MII Data Register (EMACMIIDATA), offset 0x014	1610
Register 7:	Ethernet MAC Flow Control (EMACFLOWCTL), offset 0x018	1611
Register 8:	Ethernet MAC VLAN Tag (EMACVLANTG), offset 0x01C	1613
Register 9:	Ethernet MAC Status (EMACSTATUS), offset 0x024	1615
Register 10:	Ethernet MAC Remote Wake-Up Frame Filter (EMACRWUFF), offset 0x028	1618
Register 11:	Ethernet MAC PMT Control and Status Register (EMACPMTCTLSTAT), offset 0x02C	1619
Register 12:	Ethernet MAC Raw Interrupt Status (EMACRIS), offset 0x038	1621
Register 13:	Ethernet MAC Interrupt Mask (EMACIM), offset 0x03C	1623
Register 14:	Ethernet MAC Address 0 High (EMACADDR0H), offset 0x040	1624
Register 15:	Ethernet MAC Address 0 Low Register (EMACADDR0L), offset 0x044	1625
Register 16:	Ethernet MAC Address 1 High (EMACADDR1H), offset 0x048	1626
Register 17:	Ethernet MAC Address 1 Low (EMACADDR1L), offset 0x04C	1628
Register 18:	Ethernet MAC Address 2 High (EMACADDR2H), offset 0x050	1629
Register 19:	Ethernet MAC Address 2 Low (EMACADDR2L), offset 0x054	1631
Register 20:	Ethernet MAC Address 3 High (EMACADDR3H), offset 0x058	1632
Register 21:	Ethernet MAC Address 3 Low (EMACADDR3L), offset 0x05C	1634
Register 22:	Ethernet MAC Watchdog Timeout (EMACWDOGTO), offset 0x0DC	1635
Register 23:	Ethernet MAC MMC Control (EMACMMCCTRL), offset 0x100	1636
Register 24:	Ethernet MAC MMC Receive Raw Interrupt Status (EMACMMCRXRIS), offset 0x104	1639
Register 25:	Ethernet MAC MMC Transmit Raw Interrupt Status (EMACMMCTXRIS), offset 0x108	1641
Register 26:	Ethernet MAC MMC Receive Interrupt Mask (EMACMMCRXIM), offset 0x10C	1643
Register 27:	Ethernet MAC MMC Transmit Interrupt Mask (EMACMMCTXIM), offset 0x110	1645
Register 28:	Ethernet MAC Transmit Frame Count for Good and Bad Frames (EMACTXCNTGB), offset 0x118	1647
Register 29:	Ethernet MAC Transmit Frame Count for Frames Transmitted after Single Collision (EMACTXCNTSCOL), offset 0x14C	1648
Register 30:	Ethernet MAC Transmit Frame Count for Frames Transmitted after Multiple Collisions (EMACTXCNTMCOL), offset 0x150	1649
Register 31:	Ethernet MAC Transmit Octet Count Good (EMACTXOCTCNTG), offset 0x164	1650

Register 32:	Ethernet MAC Receive Frame Count for Good and Bad Frames (EMACRXCNTGB), offset 0x180	1651
Register 33:	Ethernet MAC Receive Frame Count for CRC Error Frames (EMACRXCNTCRCERR), offset 0x194	1652
Register 34:	Ethernet MAC Receive Frame Count for Alignment Error Frames (EMACRXCNTALGNERR), offset 0x198	1653
Register 35:	Ethernet MAC Receive Frame Count for Good Unicast Frames (EMACRXCNTGUNI), offset 0x1C4	1654
Register 36:	Ethernet MAC VLAN Tag Inclusion or Replacement (EMACVLNINCREP), offset 0x584	1655
Register 37:	Ethernet MAC VLAN Hash Table (EMACVLNHASH), offset 0x588	1657
Register 38:	Ethernet MAC Timestamp Control (EMACTIMSTCTRL), offset 0x700	1658
Register 39:	Ethernet MAC Sub-Second Increment (EMACSUBSECINC), offset 0x704	1662
Register 40:	Ethernet MAC System Time - Seconds (EMACTIMSEC), offset 0x708	1663
Register 41:	Ethernet MAC System Time - Nanoseconds (EMACTIMNANO), offset 0x70C	1664
Register 42:	Ethernet MAC System Time - Seconds Update (EMACTIMSECU), offset 0x710	1665
Register 43:	Ethernet MAC System Time - Nanoseconds Update (EMACTIMNANOU), offset 0x714	1666
Register 44:	Ethernet MAC Timestamp Addend (EMACTIMADD), offset 0x718	1667
Register 45:	Ethernet MAC Target Time Seconds (EMACTARGSEC), offset 0x71C	1668
Register 46:	Ethernet MAC Target Time Nanoseconds (EMACTARGNANO), offset 0x720	1669
Register 47:	Ethernet MAC System Time-Higher Word Seconds (EMACHWORDSEC), offset 0x724	1670
Register 48:	Ethernet MAC Timestamp Status (EMACTIMSTAT), offset 0x728	1671
Register 49:	Ethernet MAC PPS Control (EMACPPSCTRL), offset 0x72C	1672
Register 50:	Ethernet MAC PPS0 Interval (EMACPPS0INTVL), offset 0x760	1675
Register 51:	Ethernet MAC PPS0 Width (EMACPPS0WIDTH), offset 0x764	1676
Register 52:	Ethernet MAC DMA Bus Mode (EMACDMABUSMOD), offset 0xC00	1677
Register 53:	Ethernet MAC Transmit Poll Demand (EMACTXPOLL), offset 0xC04	1681
Register 54:	Ethernet MAC Receive Poll Demand (EMACRXPOLLD), offset 0xC08	1682
Register 55:	Ethernet MAC Receive Descriptor List Address (EMACRXDLADDR), offset 0xC0C	1683
Register 56:	Ethernet MAC Transmit Descriptor List Address (EMACTXDLADDR), offset 0xC10	1684
Register 57:	Ethernet MAC DMA Interrupt Status (EMACDMARIS), offset 0xC14	1685
Register 58:	Ethernet MAC DMA Operation Mode (EMACDMAOPMODE), offset 0xC18	1691
Register 59:	Ethernet MAC DMA Interrupt Mask Register (EMACDMAIM), offset 0xC1C	1696
Register 60:	Ethernet MAC Missed Frame and Buffer Overflow Counter (EMACMFBOC), offset 0xC20	1699
Register 61:	Ethernet MAC Receive Interrupt Watchdog Timer (EMACRXINTWDT), offset 0xC24	1700
Register 62:	Ethernet MAC Current Host Transmit Descriptor (EMACHOSTXDESC), offset 0xC48	1701
Register 63:	Ethernet MAC Current Host Receive Descriptor (EMACHOSRXDESC), offset 0xC4C	1702
Register 64:	Ethernet MAC Current Host Transmit Buffer Address (EMACHOSTXBA), offset 0xC50	1703
Register 65:	Ethernet MAC Current Host Receive Buffer Address (EMACHOSRXBA), offset 0xC54	1704
Register 66:	Ethernet MAC Peripheral Property Register (EMACPP), offset 0xFC0	1705
Register 67:	Ethernet MAC Peripheral Configuration Register (EMACPC), offset 0xFC4	1706
Register 68:	Ethernet MAC Clock Configuration Register (EMACCC), offset 0xFC8	1710
Register 69:	Ethernet PHY Raw Interrupt Status (EPHYRIS), offset 0xFD0	1711
Register 70:	Ethernet PHY Interrupt Mask (EPHYIM), offset 0xFD4	1712
Register 71:	Ethernet PHY Masked Interrupt Status and Clear (EPHYMISC), offset 0xFD8	1713
Register 72:	Ethernet PHY Basic Mode Control - MR0 (EPHYBMCR), address 0x000	1714
Register 73:	Ethernet PHY Basic Mode Status - MR1 (EPHYBMSR), address 0x001	1716
Register 74:	Ethernet PHY Identifier Register 1 - MR2 (EPHYID1), address 0x002	1719
Register 75:	Ethernet PHY Identifier Register 2 - MR3 (EPHYID2), address 0x003	1720

Register 76:	Ethernet PHY Auto-Negotiation Advertisement - MR4 (EPHYANA), address 0x004	1721
Register 77:	Ethernet PHY Auto-Negotiation Link Partner Ability - MR5 (EPHYANLPA), address 0x005	1723
Register 78:	Ethernet PHY Auto-Negotiation Expansion - MR6 (EPHYANER), address 0x006	1725
Register 79:	Ethernet PHY Auto-Negotiation Next Page TX - MR7 (EPHYANNPTR), address 0x007	1726
Register 80:	Ethernet PHY Auto-Negotiation Link Partner Ability Next Page - MR8 (EPHYANLNPTR), address 0x008	1728
Register 81:	Ethernet PHY Configuration 1 - MR9 (EPHYCFG1), address 0x009	1730
Register 82:	Ethernet PHY Configuration 2 - MR10 (EPHYCFG2), address 0x00A	1733
Register 83:	Ethernet PHY Configuration 3 - MR11 (EPHYCFG3), address 0x00B	1735
Register 84:	Ethernet PHY Register Control - MR13 (EPHYREGCTL), address 0x00D	1737
Register 85:	Ethernet PHY Address or Data - MR14 (EPHYADDAR), address 0x00E	1739
Register 86:	Ethernet PHY Status - MR16 (EPHYSTS), address 0x010	1740
Register 87:	Ethernet PHY Specific Control- MR17 (EPHYSCR), address 0x011	1743
Register 88:	Ethernet PHY MII Interrupt Status 1 - MR18 (EPHYMISR1), address 0x012	1746
Register 89:	Ethernet PHY MII Interrupt Status 2 - MR19 (EPHYMISR2), address 0x013	1749
Register 90:	Ethernet PHY False Carrier Sense Counter - MR20 (EPHYFCSCR), address 0x014	1752
Register 91:	Ethernet PHY Receive Error Count - MR21 (EPHYRXERCNT), address 0x015	1753
Register 92:	Ethernet PHY BIST Control - MR22 (EPHYBISTCR), address 0x016	1754
Register 93:	Ethernet PHY LED Control - MR24 (EPHYLEDCR), address 0x018	1757
Register 94:	Ethernet PHY Control - MR25 (EPHYCTL), address 0x019	1758
Register 95:	Ethernet PHY 10Base-T Status/Control - MR26 (EPHY10BTSC), address 0x01A	1760
Register 96:	Ethernet PHY BIST Control and Status 1 - MR27 (EPHYBICSR1), address 0x01B	1762
Register 97:	Ethernet PHY BIST Control and Status 2 - MR28 (EPHYBICSR2), address 0x01C	1763
Register 98:	Ethernet PHY Cable Diagnostic Control - MR30 (EPHYCDCR), address 0x01E	1764
Register 99:	Ethernet PHY Reset Control - MR31 (EPHYRCR), address 0x01F	1765
Register 100:	Ethernet PHY LED Configuration - MR37 (EPHYLEDCFG), address 0x025	1766
Analog Comparators		1777
Register 1:	Analog Comparator Masked Interrupt Status (ACMIS), offset 0x000	1784
Register 2:	Analog Comparator Raw Interrupt Status (ACRIS), offset 0x004	1785
Register 3:	Analog Comparator Interrupt Enable (ACINTEN), offset 0x008	1786
Register 4:	Analog Comparator Reference Voltage Control (ACREFCTL), offset 0x010	1787
Register 5:	Analog Comparator Status 0 (ACSTAT0), offset 0x020	1788
Register 6:	Analog Comparator Status 1 (ACSTAT1), offset 0x040	1788
Register 7:	Analog Comparator Status 2 (ACSTAT2), offset 0x060	1788
Register 8:	Analog Comparator Control 0 (ACCTL0), offset 0x024	1789
Register 9:	Analog Comparator Control 1 (ACCTL1), offset 0x044	1789
Register 10:	Analog Comparator Control 2 (ACCTL2), offset 0x064	1789
Register 11:	Analog Comparator Peripheral Properties (ACMPPP), offset 0xFC0	1791
Pulse Width Modulator (PWM)		1793
Register 1:	PWM Master Control (PWMCTL), offset 0x000	1807
Register 2:	PWM Time Base Sync (PWMSYNC), offset 0x004	1809
Register 3:	PWM Output Enable (PWMENABLE), offset 0x008	1810
Register 4:	PWM Output Inversion (PWMINVERT), offset 0x00C	1812
Register 5:	PWM Output Fault (PWMFAULT), offset 0x010	1814
Register 6:	PWM Interrupt Enable (PWMINTEN), offset 0x014	1816
Register 7:	PWM Raw Interrupt Status (PWMRIS), offset 0x018	1818
Register 8:	PWM Interrupt Status and Clear (PWMISC), offset 0x01C	1821

Register 9:	PWM Status (PWMSTATUS), offset 0x020	1824
Register 10:	PWM Fault Condition Value (PWMFAULTVAL), offset 0x024	1826
Register 11:	PWM Enable Update (PWMENUUPD), offset 0x028	1828
Register 12:	PWM0 Control (PWM0CTL), offset 0x040	1832
Register 13:	PWM1 Control (PWM1CTL), offset 0x080	1832
Register 14:	PWM2 Control (PWM2CTL), offset 0x0C0	1832
Register 15:	PWM3 Control (PWM3CTL), offset 0x100	1832
Register 16:	PWM0 Interrupt and Trigger Enable (PWM0INTEN), offset 0x044	1837
Register 17:	PWM1 Interrupt and Trigger Enable (PWM1INTEN), offset 0x084	1837
Register 18:	PWM2 Interrupt and Trigger Enable (PWM2INTEN), offset 0x0C4	1837
Register 19:	PWM3 Interrupt and Trigger Enable (PWM3INTEN), offset 0x104	1837
Register 20:	PWM0 Raw Interrupt Status (PWM0RIS), offset 0x048	1840
Register 21:	PWM1 Raw Interrupt Status (PWM1RIS), offset 0x088	1840
Register 22:	PWM2 Raw Interrupt Status (PWM2RIS), offset 0x0C8	1840
Register 23:	PWM3 Raw Interrupt Status (PWM3RIS), offset 0x108	1840
Register 24:	PWM0 Interrupt Status and Clear (PWM0ISC), offset 0x04C	1842
Register 25:	PWM1 Interrupt Status and Clear (PWM1ISC), offset 0x08C	1842
Register 26:	PWM2 Interrupt Status and Clear (PWM2ISC), offset 0x0CC	1842
Register 27:	PWM3 Interrupt Status and Clear (PWM3ISC), offset 0x10C	1842
Register 28:	PWM0 Load (PWM0LOAD), offset 0x050	1844
Register 29:	PWM1 Load (PWM1LOAD), offset 0x090	1844
Register 30:	PWM2 Load (PWM2LOAD), offset 0x0D0	1844
Register 31:	PWM3 Load (PWM3LOAD), offset 0x110	1844
Register 32:	PWM0 Counter (PWM0COUNT), offset 0x054	1845
Register 33:	PWM1 Counter (PWM1COUNT), offset 0x094	1845
Register 34:	PWM2 Counter (PWM2COUNT), offset 0x0D4	1845
Register 35:	PWM3 Counter (PWM3COUNT), offset 0x114	1845
Register 36:	PWM0 Compare A (PWM0CMPA), offset 0x058	1846
Register 37:	PWM1 Compare A (PWM1CMPA), offset 0x098	1846
Register 38:	PWM2 Compare A (PWM2CMPA), offset 0x0D8	1846
Register 39:	PWM3 Compare A (PWM3CMPA), offset 0x118	1846
Register 40:	PWM0 Compare B (PWM0CMPB), offset 0x05C	1847
Register 41:	PWM1 Compare B (PWM1CMPB), offset 0x09C	1847
Register 42:	PWM2 Compare B (PWM2CMPB), offset 0x0DC	1847
Register 43:	PWM3 Compare B (PWM3CMPB), offset 0x11C	1847
Register 44:	PWM0 Generator A Control (PWM0GENA), offset 0x060	1848
Register 45:	PWM1 Generator A Control (PWM1GENA), offset 0x0A0	1848
Register 46:	PWM2 Generator A Control (PWM2GENA), offset 0x0E0	1848
Register 47:	PWM3 Generator A Control (PWM3GENA), offset 0x120	1848
Register 48:	PWM0 Generator B Control (PWM0GENB), offset 0x064	1851
Register 49:	PWM1 Generator B Control (PWM1GENB), offset 0x0A4	1851
Register 50:	PWM2 Generator B Control (PWM2GENB), offset 0x0E4	1851
Register 51:	PWM3 Generator B Control (PWM3GENB), offset 0x124	1851
Register 52:	PWM0 Dead-Band Control (PWM0DBCTL), offset 0x068	1854
Register 53:	PWM1 Dead-Band Control (PWM1DBCTL), offset 0x0A8	1854
Register 54:	PWM2 Dead-Band Control (PWM2DBCTL), offset 0x0E8	1854
Register 55:	PWM3 Dead-Band Control (PWM3DBCTL), offset 0x128	1854
Register 56:	PWM0 Dead-Band Rising-Edge Delay (PWM0DBRISE), offset 0x06C	1855

Register 57:	PWM1 Dead-Band Rising-Edge Delay (PWM1DBRISE), offset 0x0AC	1855
Register 58:	PWM2 Dead-Band Rising-Edge Delay (PWM2DBRISE), offset 0x0EC	1855
Register 59:	PWM3 Dead-Band Rising-Edge Delay (PWM3DBRISE), offset 0x12C	1855
Register 60:	PWM0 Dead-Band Falling-Edge-Delay (PWM0DBFALL), offset 0x070	1856
Register 61:	PWM1 Dead-Band Falling-Edge-Delay (PWM1DBFALL), offset 0x0B0	1856
Register 62:	PWM2 Dead-Band Falling-Edge-Delay (PWM2DBFALL), offset 0x0F0	1856
Register 63:	PWM3 Dead-Band Falling-Edge-Delay (PWM3DBFALL), offset 0x130	1856
Register 64:	PWM0 Fault Source 0 (PWM0FLTSRC0), offset 0x074	1857
Register 65:	PWM1 Fault Source 0 (PWM1FLTSRC0), offset 0x0B4	1857
Register 66:	PWM2 Fault Source 0 (PWM2FLTSRC0), offset 0x0F4	1857
Register 67:	PWM3 Fault Source 0 (PWM3FLTSRC0), offset 0x134	1857
Register 68:	PWM0 Fault Source 1 (PWM0FLTSRC1), offset 0x078	1859
Register 69:	PWM1 Fault Source 1 (PWM1FLTSRC1), offset 0x0B8	1859
Register 70:	PWM2 Fault Source 1 (PWM2FLTSRC1), offset 0x0F8	1859
Register 71:	PWM3 Fault Source 1 (PWM3FLTSRC1), offset 0x138	1859
Register 72:	PWM0 Minimum Fault Period (PWM0MINFLTPER), offset 0x07C	1862
Register 73:	PWM1 Minimum Fault Period (PWM1MINFLTPER), offset 0x0BC	1862
Register 74:	PWM2 Minimum Fault Period (PWM2MINFLTPER), offset 0x0FC	1862
Register 75:	PWM3 Minimum Fault Period (PWM3MINFLTPER), offset 0x13C	1862
Register 76:	PWM0 Fault Pin Logic Sense (PWM0FLTSEN), offset 0x800	1863
Register 77:	PWM1 Fault Pin Logic Sense (PWM1FLTSEN), offset 0x880	1863
Register 78:	PWM2 Fault Pin Logic Sense (PWM2FLTSEN), offset 0x900	1863
Register 79:	PWM3 Fault Pin Logic Sense (PWM3FLTSEN), offset 0x980	1863
Register 80:	PWM0 Fault Status 0 (PWM0FLTSTAT0), offset 0x804	1864
Register 81:	PWM1 Fault Status 0 (PWM1FLTSTAT0), offset 0x884	1864
Register 82:	PWM2 Fault Status 0 (PWM2FLTSTAT0), offset 0x904	1864
Register 83:	PWM3 Fault Status 0 (PWM3FLTSTAT0), offset 0x984	1864
Register 84:	PWM0 Fault Status 1 (PWM0FLTSTAT1), offset 0x808	1866
Register 85:	PWM1 Fault Status 1 (PWM1FLTSTAT1), offset 0x888	1866
Register 86:	PWM2 Fault Status 1 (PWM2FLTSTAT1), offset 0x908	1866
Register 87:	PWM3 Fault Status 1 (PWM3FLTSTAT1), offset 0x988	1866
Register 88:	PWM Peripheral Properties (PWMPP), offset 0xFC0	1869
Register 89:	PWM Clock Configuration (PWMCC), offset 0xFC8	1871
Quadrature Encoder Interface (QEI)		1872
Register 1:	QEI Control (QEICTL), offset 0x000	1879
Register 2:	QEI Status (QEISTAT), offset 0x004	1882
Register 3:	QEI Position (QEIPOS), offset 0x008	1883
Register 4:	QEI Maximum Position (QEIMAXPOS), offset 0x00C	1884
Register 5:	QEI Timer Load (QEILOAD), offset 0x010	1885
Register 6:	QEI Timer (QEITIME), offset 0x014	1886
Register 7:	QEI Velocity Counter (QEICOUNT), offset 0x018	1887
Register 8:	QEI Velocity (QEISPEED), offset 0x01C	1888
Register 9:	QEI Interrupt Enable (QEIINTEN), offset 0x020	1889
Register 10:	QEI Raw Interrupt Status (QEIRIS), offset 0x024	1891
Register 11:	QEI Interrupt Status and Clear (QEIISC), offset 0x028	1893

Revision History

The revision history table notes changes made between the indicated revisions of the TM4C129ENCPDT data sheet.

Table 1. Revision History

Date	Revision	Description
June 2014	15863.2743	<ul style="list-style-type: none"> ■ In ADC chapter, clarified section "Sample and Hold Window Control". ■ In SSI chapter: <ul style="list-style-type: none"> – Noted that during idle periods the transmit data line SSInTx is tristated. – Added clarification to uDMA section about wait states. ■ In Ethernet chapter: <ul style="list-style-type: none"> – Corrected functional description of DMA descriptors. – Added description of Receive Checksum Offload Engine. ■ In Electrical Characteristics chapter: <ul style="list-style-type: none"> – In "Power and Brown-Out Levels" table, updated V_{POR} with characterized values. – In "PIOSC Clock Characteristics" table, clarified F_{PIOSC} values. – In "Low-Frequency Internal Oscillator Characteristics" table, updated F_{LFIOSC} with characterized values. – In "Main Oscillator Input Characteristics" table, removed Pending Characterization footnote. – In "ADC Electrical Characteristics for ADC at 1 Msps" table, updated Max value for VIN_{CM}. – In "ADC Electrical Characteristics for ADC at 2 Msps" table, updated values for VIN_{CM}, R_S, f_{CONV}, T_S, T_{LT}, and the Dynamic Characteristics. – In "Current Consumption" table, updated values that were pending. ■ In Package Information appendix: <ul style="list-style-type: none"> – Moved Orderable Part Numbers table to addendum. – Deleted Packaging Materials section and put into separate packaging document. ■ Additional minor data sheet clarifications and corrections.
April 2014	15802.2729	<ul style="list-style-type: none"> ■ In the System Control chapter: <ul style="list-style-type: none"> – Clarified Hibernation Module reset section. – Added clarifications in Deep-Sleep Mode section. – Added reset for DID1 register. – Corrected description for RESC register, and changed bit 6 HIB Reset to reserved. – Added note to DSSYSDIV bit in DSCLKCFG register that values 0x0 and 0x1 should not be used. – Added clarification to FLASHPM bit in DSLPPWRCFG register when using the LFIOSC as the Deep-Sleep clock source. – Added four registers, UNIQUEIDn, which combined provide a 128-bit unique identifier for each device. ■ In the Hibernation chapter, added clarification to Hibernation Control (HIBCTL) register about External Wake and Interrupt Pin Enable bit. ■ In the Internal Memory chapter, added information on soft reset handling to the EEPROM section. ■ In the GPIO chapter: <ul style="list-style-type: none"> – Replaced table GPIO Pins With Non-Zero Reset Values with table GPIO Pins With Special Considerations. – Added note about preventing false interrupts. ■ In the Timer chapter, clarified behavior of TnMIE and TnCINTD bits in the GPTM Timer n Mode (GPTMTnMR) registers. ■ In the ADC chapter: <ul style="list-style-type: none"> – Corrected ADC maximum sample rate to two million samples/second.

Table 1. Revision History (continued)

Date	Revision	Description
		<ul style="list-style-type: none"> – Corrected figure ADC Input Equivalency. – Removed Dither Enable bit and corrected reset for ADCCTL register. ■ In the UART chapter, clarified that for a receive timeout, the RTIM bit in the UARTIM register must be set to see the RTMIS and RTRIS status in the UARTMIS and UARTRIS registers. ■ In the SSI chapter: <ul style="list-style-type: none"> – Clarified Receive FIFO operation. – Clarified DMA operation. – Removed End of Transmission (EOT) bit 4 from QSSI Control 1 (SSICR1) register. ■ In the Ethernet chapter, clarified Initialization and Configuration. ■ In the USB chapter, added important note that when configured as a bus-powered Device, the USB can operate in SUSPEND mode but produces a higher power draw than required to be compliant. ■ In the Electrical Characteristics chapter: <ul style="list-style-type: none"> – In Reset Characteristics table, updated internal reset time parameter values. – In PIOSC Clock Characteristics table, updated parameter values. – In Hibernation External Oscillator (XOSC) Input Characteristics table, removed parameter C0 Crystal shunt capacitance. – Updated Crystal Parameters table. – In Hibernation Module Tamper I/O Characteristics table, updated TMPRn pull-up resistor parameter values. – In Flash Memory Characteristics table, updated T_{PROG64} nom value. – In EEPROM Characteristics table, added values for Read access time and removed EEPROM recovery Power-On Reset delay parameter. – In EPI PSRAM Interface Characteristics table, updated Min value for EPI_CLK period. – In ADC Electrical Characteristics at 1 Msp table, updated values for V_{ADCIN} parameter. – Corrected ADC Input Equivalency diagram. – In Bi- and Quad-SSI Characteristics table, added clarifying footnotes. – Added PWM Timing Characteristics table. – Updated Current Consumption table. – In Peripheral Current Consumption table, updated I_{DDEMAC} Nom value. ■ In Package Information appendix: <ul style="list-style-type: none"> – Updated Orderable Devices section to reflect silicon revision 3 part numbers. – Added Device Nomenclature section. – Deleted packaging materials section and put into separate document. ■ Additional minor data sheet clarifications and corrections.
December 2013	15638.2711	<ul style="list-style-type: none"> ■ Changed NDA (Non-Disclosure Agreement) footer to indicate NDA only applies to USB content. ■ In System Control chapter: <ul style="list-style-type: none"> – Added sections "Optional Clock Output Signal (DIVSCLK)" and "Hardware System Service Request". – Removed some registers and bits: <ul style="list-style-type: none"> • LDORDRIS bit from Raw Interrupt Status (RIS) register, LDORDIM bit from Interrupt Mask Control (IMC) register, and LDORDMIS bit from Masked Interrupt Status and Clear (MISC) register • Deep Sleep Mode Memory Timing Register 0 for Main Flash and EEPROM (DSMENTIM0) register • LDO Power Calibration (LDOPCAL) register • LDO Sleep Power Control (LDOSPCTL) register • LMINERR bit from Sleep/Deep-Sleep Power Mode Status (SDPMST) register – Added LDOSME, TSPDE, PIOSCPDE, SRAMSM, SRAMLPM, FLASHLPM, and LDOSSEQ bits in SYSPROP register. ■ In Internal Memory chapter:

Table 1. Revision History (*continued*)

Date	Revision	Description
		<ul style="list-style-type: none"> – Added subsections to "Flash Memory" section about Execute-Only Protection, Read-Only Protection and Permanently Disabling Debug. – Removed <code>INVPL</code> bit from EEPROM Done Status (EEDONE) register. – Updated table "MEMTIMO Register Configuration vs. Frequency" with lower wait states, and improved performance values. – Added EEPROM initialization code to "EEPROM Initialization and Configuration" section. ■ In the ADC chapter: <ul style="list-style-type: none"> – Added section "Sample and Hold Window Control" and clarified section "Sample Phase Control". – Clarified description of ADC Sample Phase Control (ADCSPC) register. ■ Updated Electrical Characteristics chapter based on characterization information received. ■ Additional minor data sheet clarifications and corrections.
October 2013	15440.2698	Initial release of NDA data sheet.

About This Document

This data sheet provides reference information for the TM4C129ENCPDT microcontroller, describing the functional blocks of the system-on-chip (SoC) device designed around the ARM® Cortex™-M4F core.

Audience

This manual is intended for system software developers, hardware designers, and application developers.

About This Manual

This document is organized into sections that correspond to each major feature.

Related Documents

The following related documents are available on the Tiva™ C Series web site at <http://www.ti.com/tiva-c>:

- *Tiva™ C Series TM4C129x Silicon Errata (literature number [SPMZ850](#))*
- *TivaWare™ Boot Loader for C Series User's Guide (literature number [SPMU301](#))*
- *TivaWare™ Graphics Library for C Series User's Guide (literature number [SPMU300](#))*
- *TivaWare™ for C Series Release Notes (literature number [SPMU299](#))*
- *TivaWare™ Peripheral Driver Library for C Series User's Guide (literature number [SPMU298](#))*
- *TivaWare™ USB Library for C Series User's Guide (literature number [SPMU297](#))*
- *Tiva™ C Series TM4C129x ROM User's Guide (literature number [SPMU363](#))*

The following related documents may also be useful:

- *ARM® Cortex™-M4 Errata (literature number [SPMZ637](#))*
- *ARM® Cortex™-M4 Technical Reference Manual*
- *ARM® Debug Interface V5 Architecture Specification*
- *ARM® Embedded Trace Macrocell Architecture Specification*
- *Cortex™-M4 instruction set chapter in the ARM® Cortex™-M4 Devices Generic User Guide (literature number [ARM DUI 0553A](#))*
- *IEEE Standard 1149.1-Test Access Port and Boundary-Scan Architecture*

This documentation list was current as of publication date. Please check the web site for additional documentation, including application notes and white papers.

Documentation Conventions

This document uses the conventions shown in Table 2 on page 53.

Table 2. Documentation Conventions

Notation	Meaning
General Register Notation	
REGISTER	APB registers are indicated in uppercase bold. For example, PBORCTL is the Power-On and Brown-Out Reset Control register. If a register name contains a lowercase n, it represents more than one register. For example, SRCRn represents any (or all) of the three Software Reset Control registers: SRCR0 , SRCR1 , and SRCR2 .
bit	A single bit in a register.
bit field	Two or more consecutive and related bits.
offset 0xnnn	A hexadecimal increment to a register's address, relative to that module's base address as specified in Table 2-4 on page 109.
Register N	Registers are numbered consecutively throughout the document to aid in referencing them. The register number has no meaning to software.
reserved	Register bits marked <i>reserved</i> are reserved for future use. In most cases, reserved bits are set to 0; however, user software should not rely on the value of a reserved bit. To provide software compatibility with future products, the value of a reserved bit should be preserved across a read-modify-write operation.
yy:xx	The range of register bits inclusive from xx to yy. For example, 31:15 means bits 15 through 31 in that register.
Register Bit/Field Types	
RC	Software can read this field. The bit or field is cleared by hardware after reading the bit/field.
RO	Software can read this field. Always write the chip reset value.
RW	Software can read or write this field.
RWC	Software can read or write this field. Writing to it with any value clears the register.
RW1C	Software can read or write this field. A write of a 0 to a W1C bit does not affect the bit value in the register. A write of a 1 clears the value of the bit in the register; the remaining bits remain unchanged. This register type is primarily used for clearing interrupt status bits where the read operation provides the interrupt status and the write of the read value clears only the interrupts being reported at the time the register was read.
RW1S	Software can read or write a 1 to this field. A write of a 0 to a RW1S bit does not affect the bit value in the register.
W1C	Software can write this field. A write of a 0 to a W1C bit does not affect the bit value in the register. A write of a 1 clears the value of the bit in the register; the remaining bits remain unchanged. A read of the register returns no meaningful data. This register is typically used to clear the corresponding bit in an interrupt register.
WO	Only a write by software is valid; a read of the register returns no meaningful data.
Register Bit/Field Reset Value	
0	Bit cleared to 0 on chip reset.
1	Bit set to 1 on chip reset.
-	Nondeterministic.
Pin/Signal Notation	
[]	Pin alternate function; a pin defaults to the signal without the brackets.
pin	Refers to the physical connection on the package.
signal	Refers to the electrical signal encoding of a pin.

Table 2. Documentation Conventions (continued)

Notation	Meaning
assert a signal	Change the value of the signal from the logically False state to the logically True state. For active High signals, the asserted signal value is 1 (High); for active Low signals, the asserted signal value is 0 (Low). The active polarity (High or Low) is defined by the signal name (see <code>SIGNAL</code> and <code>$\overline{\text{SIGNAL}}$</code> below).
deassert a signal	Change the value of the signal from the logically True state to the logically False state.
<code>$\overline{\text{SIGNAL}}$</code>	Signal names are in uppercase and in the Courier font. An overbar on a signal name indicates that it is active Low. To assert <code>$\overline{\text{SIGNAL}}$</code> is to drive it Low; to deassert <code>$\overline{\text{SIGNAL}}$</code> is to drive it High.
<code>SIGNAL</code>	Signal names are in uppercase and in the Courier font. An active High signal has no overbar. To assert <code>SIGNAL</code> is to drive it High; to deassert <code>SIGNAL</code> is to drive it Low.
Numbers	
X	An uppercase X indicates any of several values is allowed, where X can be any legal pattern. For example, a binary value of 0X00 can be either 0100 or 0000, a hex value of 0xX is 0x0 or 0x1, and so on.
0x	Hexadecimal numbers have a prefix of 0x. For example, 0x00FF is the hexadecimal number FF. All other numbers within register tables are assumed to be binary. Within conceptual information, binary numbers are indicated with a b suffix, for example, 1011b, and decimal numbers are written without a prefix or suffix.

1 Architectural Overview

Texas Instrument's Tiva™ C Series microcontrollers provide designers a high-performance ARM® Cortex™-M-based architecture with a broad set of integration capabilities and a strong ecosystem of software and development tools. Targeting performance and flexibility, the Tiva™ C Series architecture offers a 120 MHz Cortex-M with FPU, a variety of integrated memories and multiple programmable GPIO. Tiva™ C Series devices offer consumers compelling cost-effective solutions by integrating application-specific peripherals and providing a comprehensive library of software tools which minimize board costs and design-cycle time. Offering quicker time-to-market and cost savings, the Tiva™ C Series microcontrollers are the leading choice in high-performance 32-bit applications.

This chapter contains an overview of the Tiva™ C Series microcontrollers as well as details on the TM4C129ENCPDT microcontroller:

- “Tiva™ C Series Overview” on page 55
- “TM4C129ENCPDT Microcontroller Overview” on page 56
- “TM4C129ENCPDT Microcontroller Features” on page 59
- “TM4C129ENCPDT Microcontroller Hardware Details” on page 84
- “Kits” on page 84
- “Support Information” on page 85

1.1 Tiva™ C Series Overview

The Tiva™ C Series ARM Cortex-M4 microcontrollers provide top performance and advanced integration. The product family is positioned for cost-effective applications requiring significant control processing and connectivity capabilities such as:

- Industrial communication equipment
- Network appliances, gateways & adapters
- Residential & commercial site monitoring & control
- Remote connectivity & monitoring
- Security/access systems
- HMI control panels
- Factory automation control
- Test and measurement equipment
- Fire & security systems
- Motion control & power inversion
- Medical instrumentation
- Gaming equipment
- Electronic point-of-sale (POS) displays
- Smart Energy/Smart Grid solutions
- Intelligent lighting control
- Vehicle tracking

Tiva™ C Series microcontrollers integrate a large variety of rich communication features to enable a new class of highly connected designs with the ability to allow critical, real-time control between performance and power. The microcontrollers feature integrated communication peripherals along with other high-performance analog and digital functions to offer a strong foundation for many different target uses, spanning from human machine interface to networked system management controllers.

In addition, Tiva™ C Series microcontrollers offer the advantages of ARM's widely available development tools, System-on-Chip (SoC) infrastructure, and a large user community. Additionally, these microcontrollers use ARM's Thumb®-compatible Thumb-2 instruction set to reduce memory requirements and, thereby, cost. Finally, the TM4C129ENC PDT microcontroller is code-compatible to all members of the extensive Tiva™ C Series, providing flexibility to fit precise needs.

Texas Instruments offers a complete solution to get to market quickly, with evaluation and development boards, white papers and application notes, an easy-to-use peripheral driver library, and a strong support, sales, and distributor network.

1.2 TM4C129ENC PDT Microcontroller Overview

The TM4C129ENC PDT microcontroller combines complex integration and high performance with the features shown in Table 1-1.

Table 1-1. TM4C129ENC PDT Microcontroller Features

Feature	Description
Performance	
Core	ARM Cortex-M4F processor core
Performance	120-MHz operation; 150 DMIPS performance
Flash	1024 KB Flash memory
System SRAM	256 KB single-cycle System SRAM
EEPROM	6KB of EEPROM
Internal ROM	Internal ROM loaded with TivaWare™ for C Series software
External Peripheral Interface (EPI)	8-/16-/32-bit dedicated interface for peripherals and memory
Security	
Cyclical Redundancy Check (CRC) Hardware	16-/32-bit Hash function that supports four CRC forms
Advanced Encryption Standard (AES)	Hardware accelerated data encryption and decryption based on 128-, 192-, and 256-bit keys
Data Encryption Standard (DES)	Block cipher implementation with 168-bit effective key length
Hardware Accelerated Hash (SHA/MD5)	Advanced hash engine that supports SHA-1, SHA-2 or MD5 Hash computation
Tamper	Support for four tamper inputs and configurable tamper event response
Communication Interfaces	
Universal Asynchronous Receivers/Transmitter (UART)	Eight UARTs
Quad Synchronous Serial Interface (QSSI)	Four SSI modules with Bi-, Quad- and advanced SSI support
Inter-Integrated Circuit (I ² C)	Ten I ² C modules with four transmission speeds including high-speed mode
Controller Area Network (CAN)	Two CAN 2.0 A/B controllers
Ethernet MAC	10/100 Ethernet MAC
Ethernet PHY	PHY with IEEE 1588 PTP hardware support
Universal Serial Bus (USB)	USB 2.0 OTG/Host/Device with ULPI interface option and Link Power Management (LPM) support
System Integration	
Micro Direct Memory Access (μDMA)	ARM® PrimeCell® 32-channel configurable μDMA controller
General-Purpose Timer (GPTM)	Eight 16/32-bit GPTM blocks
Watchdog Timer (WDT)	Two watchdog timers

Table 1-1. TM4C129ENCPDT Microcontroller Features (continued)

Feature	Description
Hibernation Module (HIB)	Low-power battery-backed Hibernation module
General-Purpose Input/Output (GPIO)	15 physical GPIO blocks
Advanced Motion Control	
Pulse Width Modulator (PWM)	One PWM module, with four PWM generator blocks and a control block, for a total of 8 PWM outputs.
Quadrature Encoder Interface (QEI)	One QEI module
Analog Support	
Analog-to-Digital Converter (ADC)	Two 12-bit ADC modules, each with a maximum sample rate of two million samples/second
Analog Comparator Controller	Three independent integrated analog comparators
Digital Comparator	16 digital comparators
JTAG and Serial Wire Debug (SWD)	One JTAG module with integrated ARM SWD
Package Information	
Package	128-pin TQFP
Operating Range (Ambient)	Industrial (-40°C to 85°C) temperature range Extended (-40°C to 105°C) temperature range

Figure 1-1 on page 58 shows the features on the TM4C129ENCPDT microcontroller. Note that there are two on-chip buses that connect the core to the peripherals. The Advanced Peripheral Bus (APB) bus is the legacy bus. The Advanced High-Performance Bus (AHB) bus provides better back-to-back access performance than the APB bus.

Figure 1-1. Tiva™ TM4C129ENCPDT Microcontroller High-Level Block Diagram

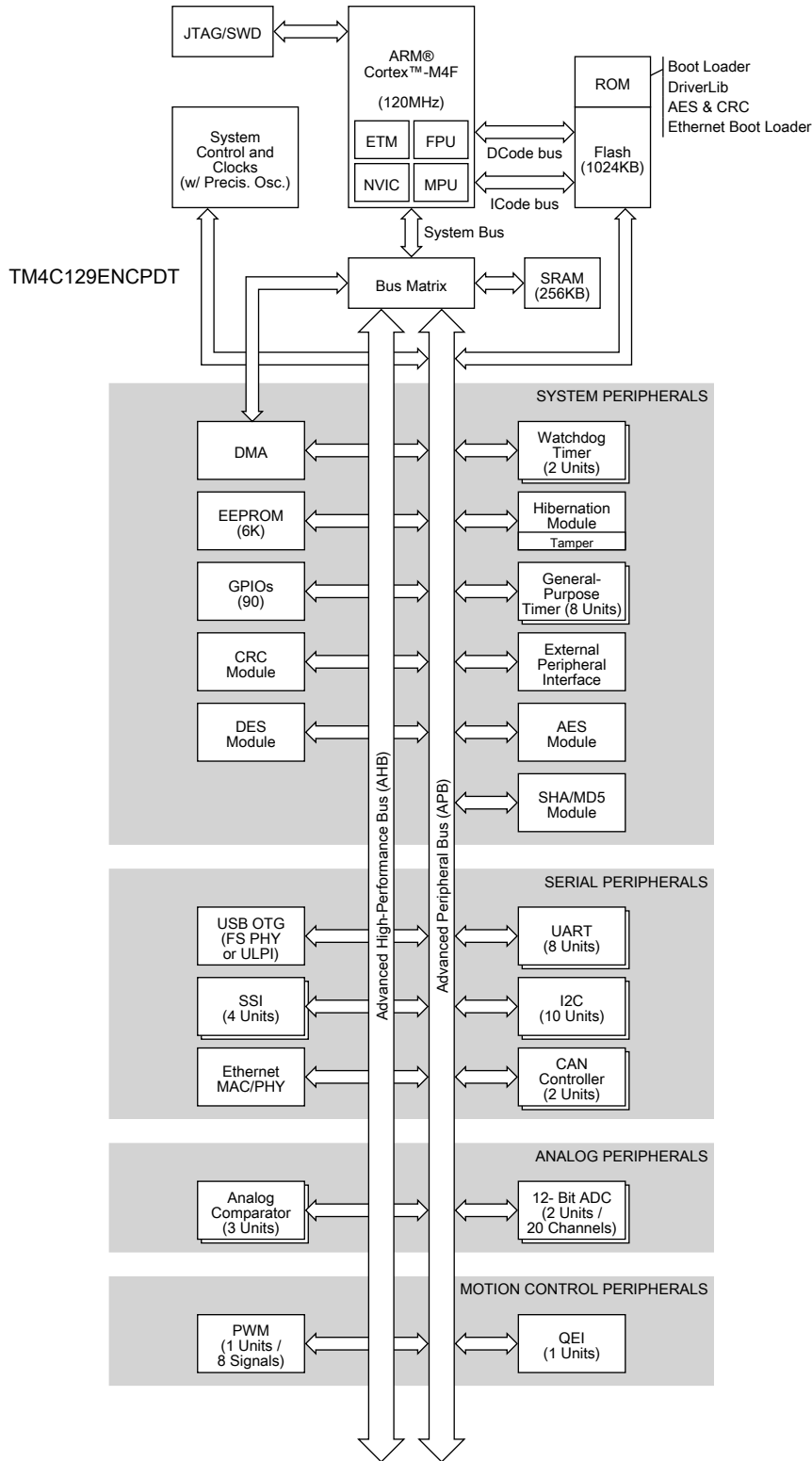

1.3 TM4C129ENCPDT Microcontroller Features

The TM4C129ENCPDT microcontroller component features and general function are discussed in more detail in the following section.

1.3.1 ARM Cortex-M4F Processor Core

All members of the Tiva™ C Series, including the TM4C129ENCPDT microcontroller, are designed around an ARM Cortex-M processor core. The ARM Cortex-M processor provides the core for a high-performance, low-cost platform that meets the needs of minimal memory implementation, reduced pin count, and low power consumption, while delivering outstanding computational performance and exceptional system response to interrupts.

1.3.1.1 Processor Core (see page 86)

- 32-bit ARM Cortex-M4F architecture optimized for small-footprint embedded applications
- 120-MHz operation; 150 DMIPS performance
- Outstanding processing performance combined with fast interrupt handling
- Thumb-2 mixed 16-/32-bit instruction set delivers the high performance expected of a 32-bit ARM core in a compact memory size usually associated with 8- and 16-bit devices, typically in the range of a few kilobytes of memory for microcontroller-class applications
 - Single-cycle multiply instruction and hardware divide
 - Atomic bit manipulation (bit-banding), delivering maximum memory utilization and streamlined peripheral control
 - Unaligned data access, enabling data to be efficiently packed into memory
- IEEE754-compliant single-precision Floating-Point Unit (FPU)
- 16-bit SIMD vector processing unit
- Fast code execution permits slower processor clock or increases sleep mode time
- Harvard architecture characterized by separate buses for instruction and data
- Efficient processor core, system and memories
- Hardware division and fast digital-signal-processing orientated multiply accumulate
- Saturating arithmetic for signal processing
- Deterministic, high-performance interrupt handling for time-critical applications
- Memory protection unit (MPU) to provide a privileged mode for protected operating system functionality
- Enhanced system debug with extensive breakpoint and trace capabilities
- Serial Wire Debug and Serial Wire Trace reduce the number of pins required for debugging and tracing

- Migration from the ARM7™ processor family for better performance and power efficiency
- Optimized for single-cycle Flash memory usage up to specific frequencies; see “Internal Memory” on page 608 for more information.
- Ultra-low power consumption with integrated sleep modes

1.3.1.2 System Timer (SysTick) (see page 142)

ARM Cortex-M4F includes an integrated system timer, SysTick. SysTick provides a simple, 24-bit, clear-on-write, decrementing, wrap-on-zero counter with a flexible control mechanism. The counter can be used in several different ways, for example:

- An RTOS tick timer that fires at a programmable rate (for example, 100 Hz) and invokes a SysTick routine
- A high-speed alarm timer using the system clock
- A variable rate alarm or signal timer—the duration is range-dependent on the reference clock used and the dynamic range of the counter
- A simple counter used to measure time to completion and time used
- An internal clock-source control based on missing/meeting durations

1.3.1.3 Nested Vectored Interrupt Controller (NVIC) (see page 143)

The TM4C129ENC PDT controller includes the ARM Nested Vectored Interrupt Controller (NVIC). The NVIC and Cortex-M4F prioritize and handle all exceptions in Handler Mode. The processor state is automatically stored to the stack on an exception and automatically restored from the stack at the end of the Interrupt Service Routine (ISR). The interrupt vector is fetched in parallel to the state saving, enabling efficient interrupt entry. The processor supports tail-chaining, meaning that back-to-back interrupts can be performed without the overhead of state saving and restoration. Software can set eight priority levels on 7 exceptions (system handlers) and 106 interrupts.

- Deterministic, fast interrupt processing: always 12 cycles, or just 6 cycles with tail-chaining (these values reflect no FPU stacking)
- External non-maskable interrupt signal (NMI) available for immediate execution of NMI handler for safety critical applications
- Dynamically reprioritizable interrupts
- Exceptional interrupt handling via hardware implementation of required register manipulations

1.3.1.4 System Control Block (SCB) (see page 144)

The SCB provides system implementation information and system control, including configuration, control, and reporting of system exceptions.

1.3.1.5 Memory Protection Unit (MPU) (see page 144)

The MPU supports the standard ARM7 Protected Memory System Architecture (PMSA) model. The MPU provides full support for protection regions, overlapping protection regions, access permissions, and exporting memory attributes to the system.

1.3.1.6 Floating-Point Unit (FPU) (see page 149)

The FPU fully supports single-precision add, subtract, multiply, divide, multiply and accumulate, and square root operations. It also provides conversions between fixed-point and floating-point data formats, and floating-point constant instructions.

- 32-bit instructions for single-precision (C float) data-processing operations
- Combined multiply and accumulate instructions for increased precision (Fused MAC)
- Hardware support for conversion, addition, subtraction, multiplication with optional accumulate, division, and square-root
- Hardware support for denormals and all IEEE rounding modes
- 32 dedicated 32-bit single-precision registers, also addressable as 16 double-word registers
- Decoupled three stage pipeline

1.3.2 On-Chip Memory

The TM4C129ENCPDT microcontroller is integrated with the following set of on-chip memory and features:

- 256 KB single-cycle SRAM
- 1024 KB Flash memory
- 6KB EEPROM
- Internal ROM loaded with TivaWare™ for C Series software:
 - TivaWare™ Peripheral Driver Library
 - TivaWare Boot Loader
 - Advanced Encryption Standard (AES) cryptography tables
 - Cyclic Redundancy Check (CRC) error detection functionality

1.3.2.1 SRAM (see page 610)

The TM4C129ENCPDT microcontroller provides 256 KB of single-cycle on-chip SRAM. The internal SRAM of the device is located at offset 0x2000.0000 of the device memory map.

The SRAM is implemented using four 32-bit wide interleaving SRAM banks (separate SRAM arrays) which allow for increased speed between memory accesses. The SRAM memory provides nearly 2 GB/s memory bandwidth at a 120 MHz clock frequency.

Because read-modify-write (RMW) operations are very time consuming, ARM has introduced *bit-banding* technology in the Cortex-M4F processor. With a bit-band-enabled processor, certain regions in the memory map (SRAM and peripheral space) can use address aliases to access individual bits in a single, atomic operation.

Data can be transferred to and from SRAM by the following masters:

- μ DMA
- USB
- Ethernet Controller

1.3.2.2 Flash Memory (see page 612)

The TM4C129ENC PDT microcontroller provides 1024 KB of on-chip Flash memory. The Flash memory is configured as four banks of 16K x 128 bits (4 * 256 KB total) which are two-way interleaved. Memory blocks can be marked as read-only or execute-only, providing different levels of code protection. Read-only blocks cannot be erased or programmed, protecting the contents of those blocks from being modified. Execute-only blocks cannot be erased or programmed, and can only be read by the controller instruction fetch mechanism, protecting the contents of those blocks from being read by either the controller or by a debugger.

The TM4C129ENC PDT microcontroller provides enhanced performance and power savings by implementation of two sets of instruction prefetch buffers. Each prefetch buffer is 2 x 256 bits and can be combined as a 4 x 256-bit prefetch buffer.

The Flash can also be accessed by the μ DMA in Run Mode.

1.3.2.3 ROM (see page 610)

The TM4C129ENC PDT ROM is preprogrammed with the following software and programs:

- TivaWare Peripheral Driver Library
- TivaWare Boot Loader
- Advanced Encryption Standard (AES) cryptography tables
- Cyclic Redundancy Check (CRC) error-detection functionality

The TivaWare Peripheral Driver Library is a royalty-free software library for controlling on-chip peripherals with a boot-loader capability. The library performs both peripheral initialization and control functions, with a choice of polled or interrupt-driven peripheral support. In addition, the library is designed to take full advantage of the stellar interrupt performance of the ARM Cortex-M4F core. No special pragmas or custom assembly code prologue/epilogue functions are required. For applications that require in-field programmability, the royalty-free TivaWare Boot Loader can act as an application loader and support in-field firmware updates.

The Advanced Encryption Standard (AES) is a publicly defined encryption standard used by the U.S. Government. AES is a strong encryption method with reasonable performance and size. In addition, it is fast in both hardware and software, is fairly easy to implement, and requires little memory. The Texas Instruments encryption package is available with full source code, and is based on Lesser General Public License (LGPL) source. An LGPL means that the code can be used within an application without any copyleft implications for the application (the code does not automatically become open source). Modifications to the package source, however, must be open source.

CRC (Cyclic Redundancy Check) is a technique to validate a span of data has the same contents as when previously checked. This technique can be used to validate correct receipt of messages (nothing lost or modified in transit), to validate data after decompression, to validate that Flash memory contents have not been changed, and for other cases where the data needs to be validated. A CRC is preferred over a simple checksum (for example, XOR all bits) because it catches changes more readily.

Note: CRC and AES software programs are available in the TivaWare™ for C Series software for backward-compatibility. A device that has enhanced CRC and AES integrated modules should utilize this hardware for best performance. Please refer to “Cyclical Redundancy Check (CRC)” on page 954 and “Advance Encryption Standard Accelerator (AES)” on page 963 for more information.

1.3.2.4 EEPROM (see page 623)

The TM4C129ENCPDT microcontroller includes an EEPROM with the following features:

- 6Kbytes of memory accessible as 1536 32-bit words
- 96 blocks of 16 words (64 bytes) each
- Built-in wear leveling
- Access protection per block
- Lock protection option for the whole peripheral as well as per block using 32-bit to 96-bit unlock codes (application selectable)
- Interrupt support for write completion to avoid polling
- Endurance of 500K writes (when writing at fixed offset in every alternate page in circular fashion) to 15M operations (when cycling through two pages) per each 2-page block.

1.3.3 External Peripheral Interface (see page 823)

The External Peripheral Interface (EPI) provides access to external devices using a parallel path. Unlike communications peripherals such as SSI, UART, and I²C, the EPI is designed to act like a bus to external peripherals and memory.

The EPI has the following features:

- 8/16/32-bit dedicated parallel bus for external peripherals and memory
- Memory interface supports contiguous memory access independent of data bus width, thus enabling code execution directly from SDRAM, SRAM and Flash memory
- Blocking and non-blocking reads
- Separates processor from timing details through use of an internal write FIFO
- Efficient transfers using Micro Direct Memory Access Controller (μDMA)
 - Separate channels for read and write
 - Read channel request asserted by programmable levels on the internal Non-Blocking Read FIFO (NBRFIFO)
 - Write channel request asserted by empty on the internal Write FIFO (WFIFO)

The EPI supports three primary functional modes: Synchronous Dynamic Random Access Memory (SDRAM) mode, Traditional Host-Bus mode, and General-Purpose mode. The EPI module also provides custom GPIOs; however, unlike regular GPIOs, the EPI module uses a FIFO in the same way as a communication mechanism and is speed-controlled using clocking.

- Synchronous Dynamic Random Access Memory (SDRAM) mode
 - Supports x16 (single data rate) SDRAM at up to 60 MHz
 - Supports low-cost SDRAMs up to 64 MB (512 megabits)

- Includes automatic refresh and access to all banks/rows
- Includes a Sleep/Standby mode to keep contents active with minimal power draw
- Multiplexed address/data interface for reduced pin count
- Host-Bus mode
 - Traditional x8 and x16 MCU bus interface capabilities
 - Similar device compatibility options as PIC, ATmega, 8051, and others
 - Access to SRAM, NOR Flash memory, and other devices, with up to 1 MB of addressing in non-multiplexed mode and 256 MB in multiplexed mode (512 MB in Host-Bus 16 mode with no byte selects)
 - Support for up to 512 Mb PSRAM in quad chip select mode, with dedicated configuration register read and write enable.
 - Support of both muxed and de-muxed address and data
 - Access to a range of devices supporting the non-address FIFO x8 and x16 interface variant, with support for external FIFO (XFIFO) EMPTY and FULL signals
 - Speed controlled, with read and write data wait-state counters
 - Support for read/write burst mode to Host Bus
 - Multiple chip select modes including single, dual, and quad chip selects, with and without ALE
 - External iRDY signal provided for stall capability of reads and writes
 - Manual chip-enable (or use extra address pins)
- General-Purpose mode
 - Wide parallel interfaces for fast communications with CPLDs and FPGAs
 - Data widths up to 32 bits
 - Data rates up to 150 MB/second
 - Optional "address" sizes from 4 bits to 20 bits
 - Optional clock output, read/write strobes, framing (with counter-based size), and clock-enable input
- General parallel GPIO
 - 1 to 32 bits, FIFOed with speed control
 - Useful for custom peripherals or for digital data acquisition and actuator controls

1.3.4 Cyclical Redundancy Check (CRC) (see page 954)

The TM4C129ENCPDT microcontroller includes a CRC computation module for uses such as message transfer and safety system checks. This module can be used in conjunction with the AES and DES modules. The CRC has the following features:

- Support four major CRC forms:
 - CRC16-CCITT as used by CCITT/ITU X.25
 - CRC16-IBM as used by USB and ANSI
 - CRC32-IEEE as used by IEEE802.3 and MPEG2
 - CRC32C as used by G.Hn
- Allows word and byte feed
- Supports auto-initialization and manual initialization
- Supports MSb and LSb
- Supports CCITT post-processing
- Can be fed by μ DMA, Flash memory and code

1.3.5 Advanced Encryption Standard (AES) Accelerator (see page 963)

The advanced encryption standard (AES) accelerator module provides hardware-accelerated data encryption and decryption operations based on a binary key. The AES module is a symmetrical cipher modules that supports a 128-bit, 192-bit, or 256-bit key in hardware for both encryption and decryption.

The AES has following features:

- Support for basic AES encrypt and decrypt operations:
 - Galois/Counter Mode (GCM), with basic GHASH operation
 - Counter Mode with CBC-MAC (CCM)
 - XTS Mode
- Availability of the following feedback operating modes:
 - Electronic Code Book Mode (ECB)
 - Cipher Block Chaining Mode (CBC)
 - Counter Mode (CTR)
 - Cipher Feedback Mode (CFB), 128-bit
 - F8 Mode
- Key sizes 128-, 192- and 256-bits

- Support for CBC_MAC and Fedora 9 (F9) authentication modes
- Basic GHASH operation (when selecting no encryption)
- Key scheduling in hardware
- Support for μ DMA transfers
- Fully synchronous design

1.3.6 Data Encryption Standard (DES) Accelerator (see page 1015)

The DES module provides hardware accelerated data encryption and decryption functions. The module runs either the single DES or the triple DES (3DES) algorithm and supports electronic codebook (ECB), cipher block chaining (CBC), and cipher feedback (CFB) modes of operation.

The DES accelerator includes the following main features:

- DES/3DES encryption and decryption.
- Feedback modes: ECB, CBC, CFB
- Host interrupt or μ DMA driven modes of operation. μ DMA support for data and context in/result out
- Fully synchronous design
- Internal wide-bus interface

1.3.7 Secure Hash Algorithm / Message Digest Algorithm (SHA/MD5) (see page 1044)

The SHA/MD5 module provides hardware-accelerated hash functions and can run:

- MD5 message digest algorithm developed by Ron Rivest in 1991
- SHA-1 algorithm compliant with the [FIPS 180-3 standard](#)
- SHA-2 (SHA-224 and SHA-256) algorithm compliant with the FIPS 180-3 standard
- Hash message authentication code (HMAC) operation

The algorithms produce a condensed representation of a message or a data file which can then be used to verify the message integrity.

The SHA/MD5 accelerator module includes the following main features:

- Hashing of 0 to $2^{33} - 2$ bytes of data (of which $2^{32} - 1$ bytes are in one pass) using the MD5, SHA-1, SHA-224, or SHA-256 hash algorithm (byte granularity only, no support for bit granularity)
- Automatic HMAC key preprocessing for HMAC keys up to 64 bytes
- Host-assisted HMAC key preprocessing for HMAC keys larger than 64 bytes
- HMAC from precomputes (inner/outer digest) for improved performance on small blocks
- Supports μ DMA operation for data and context in/result out transfers
- Supports interrupt to read the digest (signature)

1.3.8 Serial Communications Peripherals

The TM4C129ENCPDT controller supports both asynchronous and synchronous serial communications with:

- 10/100 Ethernet MAC with Advanced IEEE 1588 PTP hardware and both Media Independent Interface (MII) and Reduced MII (RMII) support; integrated PHY provided
- Two CAN 2.0 A/B controllers
- USB 2.0 Controller OTG/Host/Device with optional high speed using external PHY through ULPI interface
- Eight UARTs with IrDA, 9-bit and ISO 7816 support.
- Ten I²C modules with four transmission speeds including high-speed mode
- Four Quad Synchronous Serial Interface modules (QSSI) with bi- and quad-SSI support

The following sections provide more detail on each of these communications functions.

1.3.8.1 Ethernet MAC and PHY (see page 1531)

The TM4C129ENCPDT Ethernet Controller consists of a fully integrated media access controller (MAC) and network physical (PHY) interface with the following features:

- Conforms to the IEEE 802.3 specification
 - 10BASE-T/100BASE-TX IEEE-802.3 compliant
 - Supports 10/100 Mbps data transmission rates
 - Supports full-duplex and half-duplex (CSMA/CD) operation
 - Supports flow control and back pressure
 - Full-featured and enhanced auto-negotiation
 - Supports IEEE 802.1Q VLAN tag detection
- Conforms to IEEE 1588-2002 Timestamp Precision Time Protocol (PTP) protocol and the IEEE 1588-2008 Advanced Timestamp specification
 - Transmit and Receive frame time stamping
 - Precision Time Protocol
 - Flexible pulse per second output
 - Supports coarse and fine correction methods
- Multiple addressing modes
 - Four MAC address filters
 - Programmable 64-bit Hash Filter for multicast address filtering

- Promiscuous mode support
- Processor offloading
 - Programmable insertion (TX) or deletion (RX) of preamble and start-of-frame data
 - Programmable generation (TX) or deletion (RX) of CRC and pad data
 - IP header and hardware checksum checking (IPv4, IPv6, TCP/UDP/ICMP)
- Highly configurable
 - LED activity selection
 - Supports network statistics with RMON/MIB counters
 - Supports Magic Packet and wakeup frames
- Efficient transfers using integrated Direct Memory Access (DMA)
 - Dual-buffer (ring) or linked-list (chained) descriptors
 - Round-robin or fixed priority arbitration between TX/RX
 - Descriptors support up to 8 kB transfer blocks size
 - Programmable interrupts for flexible system implementation
- Physical media manipulation
 - MDI/MDI-X cross-over support
 - Register-programmable transmit amplitude
 - Automatic polarity correction and 10BASE-T signal reception

1.3.8.2 Controller Area Network (CAN) (see page 1480)

Controller Area Network (CAN) is a multicast shared serial-bus standard for connecting electronic control units (ECUs). CAN was specifically designed to be robust in electromagnetically noisy environments and can utilize a differential balanced line like RS-485 or twisted-pair wire. Originally created for automotive purposes, it is now used in many embedded control applications (for example, industrial or medical). Bit rates up to 1 Mbps are possible at network lengths below 40 meters. Decreased bit rates allow longer network distances (for example, 125 Kbps at 500m).

A transmitter sends a message to all CAN nodes (broadcasting). Each node decides on the basis of the identifier received whether it should process the message. The identifier also determines the priority that the message enjoys in competition for bus access. Each CAN message can transmit from 0 to 8 bytes of user information.

The TM4C129ENCPDT microcontroller includes two CAN units with the following features:

- CAN protocol version 2.0 part A/B
- Bit rates up to 1 Mbps
- 32 message objects with individual identifier masks

- Maskable interrupt
- Disable Automatic Retransmission mode for Time-Triggered CAN (TTCAN) applications
- Programmable loopback mode for self-test operation
- Programmable FIFO mode enables storage of multiple message objects
- Gluelessly attaches to an external CAN transceiver through the `CANnTX` and `CANnRX` signals

1.3.8.3 Universal Serial Bus (USB) (see page 1768)

Universal Serial Bus (USB) is a serial bus standard designed to allow peripherals to be connected and disconnected using a standardized interface without rebooting the system.

The TM4C129ENCPDT microcontroller has one USB controller that supports high and full speed multi-point communications and complies with the USB 2.0 standard for high-speed function. The USB controller can have three configurations: USB Device, USB Host, and USB On-The-Go (negotiated on-the-go as host or device when connected to other USB-enabled systems). Support for full-speed communication is provided by using the integrated USB PHY or optionally, a high-speed ULPI interface can communicate to an external PHY.

The USB module has the following features:

- Complies with USB-IF (Implementer's Forum) certification standards
- USB 2.0 high-speed (480 Mbps) operation with the integrated ULPI interface communicating with an external PHY
- Link Power Management support which uses link-state awareness to reduce power usage
- 4 transfer types: Control, Interrupt, Bulk, and Isochronous
- 16 endpoints
 - 1 dedicated control IN endpoint and 1 dedicated control OUT endpoint
 - 7 configurable IN endpoints and 7 configurable OUT endpoints
- 4 KB dedicated endpoint memory: one endpoint may be defined for double-buffered 1023-byte isochronous packet size
- VBUS droop detection and interrupt
- Integrated USB DMA with bus master capability
 - Up to eight RX Endpoint channels and up to eight TX Endpoint channels are available.
 - Each channel can be separately programmed to operate in different modes
 - Incremental burst transfers of 4-, 8-, 16- or unspecified length supported

1.3.8.4 UART (see page 1285)

A Universal Asynchronous Receiver/Transmitter (UART) is an integrated circuit used for RS-232C serial communications, containing a transmitter (parallel-to-serial converter) and a receiver (serial-to-parallel converter), each clocked separately.

The TM4C129ENCPDT microcontroller includes eight fully programmable 16C550-type UARTs. Although the functionality is similar to a 16C550 UART, this UART design is not register compatible. The UART can generate individually masked interrupts from the Rx, Tx, modem flow control, modem status, and error conditions. The module generates a single combined interrupt when any of the interrupts are asserted and are unmasked.

The eight UARTs have the following features:

- Programmable baud-rate generator allowing speeds up to 7.5 Mbps for regular speed (divide by 16) and 15 Mbps for high speed (divide by 8)
- Separate 16x8 transmit (TX) and receive (RX) FIFOs to reduce CPU interrupt service loading
- Programmable FIFO length, including 1-byte deep operation providing conventional double-buffered interface
- FIFO trigger levels of 1/8, 1/4, 1/2, 3/4, and 7/8
- Standard asynchronous communication bits for start, stop, and parity
- Line-break generation and detection
- Fully programmable serial interface characteristics
 - 5, 6, 7, or 8 data bits
 - Even, odd, stick, or no-parity bit generation/detection
 - 1 or 2 stop bit generation
- IrDA serial-IR (SIR) encoder/decoder providing
 - Programmable use of IrDA Serial Infrared (SIR) or UART input/output
 - Support of IrDA SIR encoder/decoder functions for data rates up to 115.2 Kbps half-duplex
 - Support of normal 3/16 and low-power (1.41-2.23 μ s) bit durations
 - Programmable internal clock generator enabling division of reference clock by 1 to 256 for low-power mode bit duration
- Support for communication with ISO 7816 smart cards
- Modem functionality available on the following UARTs:
 - UART0 (modem flow control and modem status)
 - UART1 (modem flow control and modem status)
 - UART2 (modem flow control)
 - UART3 (modem flow control)
 - UART4 (modem flow control)
- EIA-485 9-bit support

- Standard FIFO-level and End-of-Transmission interrupts
- Efficient transfers using Micro Direct Memory Access Controller (μ DMA)
 - Separate channels for transmit and receive
 - Receive single request asserted when data is in the FIFO; burst request asserted at programmed FIFO level
 - Transmit single request asserted when there is space in the FIFO; burst request asserted at programmed FIFO level
- Global Alternate Clock (ALTCLK) resource or System Clock (SYSCLK) can be used to generate baud clock

1.3.8.5 I²C (see page 1399)

The Inter-Integrated Circuit (I²C) bus provides bi-directional data transfer through a two-wire design (a serial data line SDA and a serial clock line SCL). The I²C bus interfaces to external I²C devices such as serial memory (RAMs and ROMs), networking devices, LCDs, tone generators, and so on. The I²C bus may also be used for system testing and diagnostic purposes in product development and manufacture.

Each device on the I²C bus can be designated as either a master or a slave. I²C module supports both sending and receiving data as either a master or a slave and can operate simultaneously as both a master and a slave. Both the I²C master and slave can generate interrupts.

The TM4C129ENCPDT microcontroller includes I²C modules with the following features:

- Devices on the I²C bus can be designated as either a master or a slave
 - Supports both transmitting and receiving data as either a master or a slave
 - Supports simultaneous master and slave operation
- Four I²C modes
 - Master transmit
 - Master receive
 - Slave transmit
 - Slave receive
- Two 8-entry FIFOs for receive and transmit data
 - FIFOs can be independently assigned to master or slave
- Four transmission speeds:
 - Standard (100 Kbps)
 - Fast-mode (400 Kbps)
 - Fast-mode plus (1 Mbps)

- High-speed mode (3.33 Mbps)
- Glitch suppression
- SMBus support through software
 - Clock low timeout interrupt
 - Dual slave address capability
 - Quick command capability
- Master and slave interrupt generation
 - Master generates interrupts when a transmit or receive operation completes (or aborts due to an error)
 - Slave generates interrupts when data has been transferred or requested by a master or when a START or STOP condition is detected
- Master with arbitration and clock synchronization, multimaster support, and 7-bit addressing mode
- Efficient transfers using Micro Direct Memory Access Controller (μ DMA)
 - Separate channels for transmit and receive
 - Ability to execute single data transfers or burst data transfers using the RX and TX FIFOs in the I²C

1.3.8.6 QSSI (see page 1350)

Quad Synchronous Serial Interface (QSSI) is a bi-directional communications interface that converts data between parallel and serial. The QSSI module performs serial-to-parallel conversion on data received from a peripheral device, and parallel-to-serial conversion on data transmitted to a peripheral device. The QSSI module can be configured as either a master or slave device. As a slave device, the QSSI module can also be configured to disable its output, which allows a master device to be coupled with multiple slave devices. The TX and RX paths are buffered with separate internal FIFOs.

The QSSI module also includes a programmable bit rate clock divider and prescaler to generate the output serial clock derived from the QSSI module's input clock. Bit rates are generated based on the input clock and the maximum bit rate is determined by the connected peripheral.

The TM4C129ENCPDT microcontroller includes four QSSI modules with the following features:

- Four QSSI channels with Advanced, Bi- and Quad-SSI functionality
- Programmable interface operation for Freescale SPI or Texas Instruments synchronous serial interfaces in Legacy Mode. Support for Freescale interface in Bi- and Quad-SSI mode.
- Master or slave operation
- Programmable clock bit rate and prescaler
- Separate transmit and receive FIFOs, each 16 bits wide and 8 locations deep
- Programmable data frame size from 4 to 16 bits

- Internal loopback test mode for diagnostic/debug testing
- Standard FIFO-based interrupts and End-of-Transmission interrupt
- Efficient transfers using Micro Direct Memory Access Controller (μ DMA)
 - Separate channels for transmit and receive
 - Receive single request asserted when data is in the FIFO; burst request asserted when FIFO contains 4 entries
 - Transmit single request asserted when there is space in the FIFO; burst request asserted when four or more entries are available to be written in the FIFO
 - Maskable μ DMA interrupts for receive and transmit complete
- Global Alternate Clock (ALTCLK) resource or System Clock (SYSCLK) can be used to generate baud clock.

1.3.9 System Integration

The TM4C129ENCPDT microcontroller provides a variety of standard system functions integrated into the device, including:

- Direct Memory Access Controller (DMA)
- System control and clocks including on-chip precision 16-MHz oscillator
- Eight 32-bit timers (each of which can be configured as two 16-bit timers)
- Lower-power battery-backed Hibernation module
- Real-Time Clock in Hibernation module
- Two Watchdog Timers
 - One timer runs off the main oscillator
 - One timer runs off the precision internal oscillator
- Up to 90 GPIOs, depending on configuration
 - Highly flexible pin muxing allows use as GPIO or one of several peripheral functions
 - Independently configurable to 2-, 4-, 8-, 10-, or 12-mA drive capability
 - Up to 4 GPIOs can have 18-mA drive capability

The following sections provide more detail on each of these functions.

1.3.9.1 Direct Memory Access (see page 686)

The TM4C129ENCPDT microcontroller includes a Direct Memory Access (DMA) controller, known as micro-DMA (μ DMA). The μ DMA controller provides a way to offload data transfer tasks from the Cortex-M4F processor, allowing for more efficient use of the processor and the available bus bandwidth. The μ DMA controller can perform transfers between memory and peripherals. It has dedicated channels for each supported on-chip module and can be programmed to automatically perform transfers between peripherals and memory as the peripheral is ready to transfer more data. The μ DMA controller provides the following features:

- ARM PrimeCell® 32-channel configurable μ DMA controller

- Support for memory-to-memory, memory-to-peripheral, and peripheral-to-memory in multiple transfer modes
 - Basic for simple transfer scenarios
 - Ping-pong for continuous data flow
 - Scatter-gather for a programmable list of up to 256 arbitrary transfers initiated from a single request
- Highly flexible and configurable channel operation
 - Independently configured and operated channels
 - Dedicated channels for supported on-chip modules
 - Flexible channel assignments
 - One channel each for receive and transmit path for bidirectional modules
 - Dedicated channel for software-initiated transfers
 - Per-channel configurable priority scheme
 - Optional software-initiated requests for any channel
- Two levels of priority
- Design optimizations for improved bus access performance between μ DMA controller and the processor core
 - μ DMA controller access is subordinate to core access
 - RAM striping
 - Peripheral bus segmentation
- Data sizes of 8, 16, and 32 bits
- Transfer size is programmable in binary steps from 1 to 1024
- Source and destination address increment size of byte, half-word, word, or no increment
- Maskable peripheral requests
- Interrupt on transfer completion, with a separate interrupt per channel

1.3.9.2 System Control and Clocks (see page 227)

System control determines the overall operation of the device. It provides information about the device, controls power-saving features, controls the clocking of the device and individual peripherals, and handles reset detection and reporting.

- Device identification information: version, part number, SRAM size, Flash memory size, and so on
- Power control

- On-chip fixed Low Drop-Out (LDO) voltage regulator
- Hibernation module handles the power-up/down 3.3 V sequencing and control for the core digital logic and analog circuits
- Low-power options for microcontroller: Sleep and Deep-Sleep modes with clock gating
- Low-power options for on-chip modules: software controls shutdown of individual peripherals and memory
- 3.3-V supply brown-out detection and reporting via interrupt or reset
- Multiple clock sources for microcontroller system clock. The TM4C129ENCPDT microcontroller is clocked by the system clock (SYSCLK) that is distributed to the processor and integrated peripherals after clock gating. The SYSCLK frequency is based on the frequency of the clock source and a divisor factor. A PLL is provided for the generation of system clock frequencies in excess of the reference clock provided. The reference clocks for the PLL are the PIOSC and the main crystal oscillator. The following clock sources are provided to the TM4C129ENCPDT microcontroller:
 - 16-MHz Precision Oscillator (PIOSC)
 - Main Oscillator (MOSC): A frequency-accurate clock source by one of two means: an external single-ended clock source is connected to the OSC0 input pin, or an external crystal is connected across the OSC0 input and OSC1 output pins.
 - Low Frequency Internal Oscillator (LFIOSC): On-chip resource used during power-saving modes
 - Hibernate RTC oscillator (RTCOSC) clock that can be configured to be the 32.768-kHz external oscillator source from the Hibernation (HIB) module or the HIB Low Frequency clock source (HIB LFIOSC), which is located within the Hibernation Module.
- Flexible reset sources
 - Power-on reset (POR)
 - Reset pin assertion
 - Brown-out reset (BOR) detector alerts to system power drops
 - Software reset
 - Watchdog timer reset
 - Hibernation module event
 - MOSC failure
- 128-bit unique identifier for individual device identification

1.3.9.3 Programmable Timers (see page 1079)

Programmable timers can be used to count or time external events that drive the Timer input pins. Each 16/32-bit GPTM block provides two 16-bit timers/counters that can be configured to operate independently as timers or event counters, or configured to operate as one 32-bit timer or one 32-bit

Real-Time Clock (RTC). Timers can also be used to trigger analog-to-digital (ADC) conversions and DMA transfers.

The General-Purpose Timer Module (GPTM) contains eight 16/32-bit GPTM blocks with the following functional options:

- Operating modes:
 - 16- or 32-bit programmable one-shot timer
 - 16- or 32-bit programmable periodic timer
 - 16-bit general-purpose timer with an 8-bit prescaler
 - 32-bit Real-Time Clock (RTC) when using an external 32.768-KHz clock as the input
 - 16-bit input-edge count- or time-capture modes with an 8-bit prescaler
 - 16-bit PWM mode with an 8-bit prescaler and software-programmable output inversion of the PWM signal
 - The System Clock or a global Alternate Clock (ALTCLK) resource can be used as timer clock source. The global ALTCLK can be:
 - PIOSC
 - Hibernation Module Real-time clock output (RTCOSC)
 - Low-frequency internal oscillator (LFIOSC)
- Count up or down
- Twelve 16/32-bit Capture Compare PWM pins (CCP)
- Daisy chaining of timer modules to allow a single timer to initiate multiple timing events
- Timer synchronization allows selected timers to start counting on the same clock cycle
- ADC event trigger
- User-enabled stalling when the microcontroller asserts CPU Halt flag during debug (excluding RTC mode)
- Ability to determine the elapsed time between the assertion of the timer interrupt and entry into the interrupt service routine
- Efficient transfers using Micro Direct Memory Access Controller (μ DMA)
 - Dedicated channel for each timer
 - Burst request generated on timer interrupt

1.3.9.4 CCP Pins (see page 1086)

Capture Compare PWM pins (CCP) can be used by the General-Purpose Timer Module to time/count external events using the CCP pin as an input. Alternatively, the GPTM can generate a simple PWM output on the CCP pin.

The TM4C129ENCPDT microcontroller includes twelve 16/32-bit CCP pins that can be programmed to operate in the following modes:

- Capture: The GP Timer is incremented/decremented by programmed events on the CCP input. The GP Timer captures and stores the current timer value when a programmed event occurs.
- Compare: The GP Timer is incremented/decremented by programmed events on the CCP input. The GP Timer compares the current value with a stored value and generates an interrupt when a match occurs.
- PWM: The GP Timer is incremented/decremented by the system clock. A PWM signal is generated based on a match between the counter value and a value stored in a match register and is output on the CCP pin.

1.3.9.5 Hibernation Module (HIB) (see page 539)

The Hibernation module provides logic to switch power off to the main processor and peripherals and to wake on external or time-based events. The Hibernation module includes power-sequencing logic and has the following features:

- 32-bit real-time seconds counter (RTC) with 1/32,768 second resolution and a 15-bit sub-seconds counter
 - 32-bit RTC seconds match register and a 15-bit sub seconds match for timed wake-up and interrupt generation with 1/32,768 second resolution
 - RTC predivider trim for making fine adjustments to the clock rate
- Hardware Calendar Function
 - Year, Month, Day, Day of Week, Hours, Minutes, Seconds
 - Four-year leap compensation
 - 24-hour or AM/PM configuration
- Two mechanisms for power control
 - System power control using discrete external regulator
 - On-chip power control using internal switches under register control
- V_{DD} supplies power when valid, even if $V_{BAT} > V_{DD}$
- Dedicated pin for waking using an external signal
- Capability to configure external reset (\overline{RST}) pin and/or up to four GPIO port pins as wake source, with programmable wake level
- Tamper Functionality
 - Support for four tamper inputs
 - Configurable level, weak pull-up, and glitch filter
 - Configurable tamper event response

- Logging of up to four tamper events
- Optional BBRAM erase on tamper detection
- Tamper wake from hibernate capability
- Hibernation clock input failure detect with a switch to the internal oscillator on detection
- RTC operational and hibernation memory valid as long as V_{DD} or V_{BAT} is valid
- Low-battery detection, signaling, and interrupt generation, with optional wake on low battery
- GPIO pin state can be retained during hibernation
- Clock source from an internal low frequency oscillator (HIB LFIOOSC) or a 32.768-kHz external crystal or oscillator
- Sixteen 32-bit words of battery-backed memory to save state during hibernation
- Programmable interrupts for:
 - RTC match
 - External wake
 - Low battery

1.3.9.6 Watchdog Timers (see page 1152)

A watchdog timer is used to regain control when a system has failed due to a software error or to the failure of an external device to respond in the expected way. The TM4C129ENCPDT Watchdog Timer can generate an interrupt, a non-maskable interrupt, or a reset when a time-out value is reached. In addition, the Watchdog Timer is ARM FIRM-compliant and can be configured to generate an interrupt to the microcontroller on its first time-out, and to generate a reset signal on its second timeout. Once the Watchdog Timer has been configured, the lock register can be written to prevent the timer configuration from being inadvertently altered.

The TM4C129ENCPDT microcontroller has two Watchdog Timer modules: Watchdog Timer 0 uses the system clock for its timer clock; Watchdog Timer 1 uses the PIOSC as its timer clock. The Watchdog Timer module has the following features:

- 32-bit down counter with a programmable load register
- Separate watchdog clock with an enable
- Programmable interrupt generation logic with interrupt masking and optional NMI function
- Lock register protection from runaway software
- Reset generation logic with an enable/disable
- User-enabled stalling when the microcontroller asserts the CPU Halt flag during debug

1.3.9.7 Programmable GPIOs (see page 750)

General-purpose input/output (GPIO) pins offer flexibility for a variety of connections. The TM4C129ENCPDT GPIO module is comprised of 15 physical GPIO blocks, each corresponding to

an individual GPIO port. The GPIO module is FiRM-compliant (compliant to the ARM Foundation IP for Real-Time Microcontrollers specification) and supports 0-90 programmable input/output pins. The number of GPIOs available depends on the peripherals being used (see “Signal Tables” on page 1896 for the signals available to each GPIO pin).

- Up to 90 GPIOs, depending on configuration
- Highly flexible pin muxing allows use as GPIO or one of several peripheral functions
- 3.3-V-tolerant in input configuration
- Advanced High Performance Bus accesses all ports:
 - Ports A-H and J; Ports K-N and P-Q
- Fast toggle capable of a change every clock cycle for ports on AHB
- Programmable control for GPIO interrupts
 - Interrupt generation masking
 - Edge-triggered on rising, falling, or both
 - Level-sensitive on High or Low values
 - Per-pin interrupts available on Port P and Port Q
- Bit masking in both read and write operations through address lines
- Can be used to initiate an ADC sample sequence or a μ DMA transfer
- Pin state can be retained during Hibernation mode; pins on port P can be programmed to wake on level in Hibernation mode
- Pins configured as digital inputs are Schmitt-triggered
- Programmable control for GPIO pad configuration
 - Weak pull-up or pull-down resistors
 - 2-mA, 4-mA, 6-mA, 8-mA, 10-mA and 12-mA pad drive for digital communication; up to four pads can sink 18-mA for high-current applications
 - Slew rate control for 8-mA, 10-mA and 12-mA pad drive
 - Open drain enables
 - Digital input enables

1.3.10 Advanced Motion Control

The TM4C129ENC PDT microcontroller provides motion control functions integrated into the device, including:

- Eight advanced PWM outputs for motion and energy applications
- Four fault inputs to promote low-latency shutdown

- One Quadrature Encoder Input (QEI)

The following provides more detail on these motion control functions.

1.3.10.1 PWM (see page 1793)

The TM4C129ENC PDT microcontroller contains one PWM module, with four PWM generator blocks and a control block, for a total of 8 PWM outputs. Pulse width modulation (PWM) is a powerful technique for digitally encoding analog signal levels. High-resolution counters are used to generate a square wave, and the duty cycle of the square wave is modulated to encode an analog signal. Typical applications include switching power supplies and motor control. The TM4C129ENC PDT PWM module consists of four PWM generator block and a control block. Each PWM generator block contains one timer (16-bit down or up/down counter), two comparators, a PWM signal generator, a dead-band generator, and an interrupt/ADC-trigger selector. Each PWM generator block produces two PWM signals that can either be independent signals or a single pair of complementary signals with dead-band delays inserted.

Each PWM generator has the following features:

- Four fault-condition handling inputs to quickly provide low-latency shutdown and prevent damage to the motor being controlled
- One 16-bit counter
 - Runs in Down or Up/Down mode
 - Output frequency controlled by a 16-bit load value
 - Load value updates can be synchronized
 - Produces output signals at zero and load value
- Two PWM comparators
 - Comparator value updates can be synchronized
 - Produces output signals on match
- PWM signal generator
 - Output PWM signal is constructed based on actions taken as a result of the counter and PWM comparator output signals
 - Produces two independent PWM signals
- Dead-band generator
 - Produces two PWM signals with programmable dead-band delays suitable for driving a half-H bridge
 - Can be bypassed, leaving input PWM signals unmodified
- Can initiate an ADC sample sequence

The control block determines the polarity of the PWM signals and which signals are passed through to the pins. The output of the PWM generation blocks are managed by the output control block before being passed to the device pins. The PWM control block has the following options:

- PWM output enable of each PWM signal
- Optional output inversion of each PWM signal (polarity control)
- Optional fault handling for each PWM signal
- Synchronization of timers in the PWM generator blocks
- Synchronization of timer/comparator updates across the PWM generator blocks
- Extended PWM synchronization of timer/comparator updates across the PWM generator blocks
- Interrupt status summary of the PWM generator blocks
- Extended PWM fault handling, with multiple fault signals, programmable polarities, and filtering
- PWM generators can be operated independently or synchronized with other generators

1.3.10.2 QEI (see page 1872)

A quadrature encoder, also known as a 2-channel incremental encoder, converts linear displacement into a pulse signal. By monitoring both the number of pulses and the relative phase of the two signals, the position, direction of rotation, and speed can be tracked. In addition, a third channel, or index signal, can be used to reset the position counter. The TM4C129ENCPDT quadrature encoder with index (QEI) module interprets the code produced by a quadrature encoder wheel to integrate position over time and determine direction of rotation. In addition, it can capture a running estimate of the velocity of the encoder wheel. The input frequency of the QEI inputs may be as high as 1/4 of the processor frequency (for example, 30 MHz for a 120-MHz system).

The TM4C129ENCPDT microcontroller includes one QEI module providing control of one motor with the following features:

- Position integrator that tracks the encoder position
- Programmable noise filter on the inputs
- Velocity capture using built-in timer
- The input frequency of the QEI inputs may be as high as 1/4 of the processor frequency (for example, 12.5 MHz for a 50-MHz system)
- Interrupt generation on:
 - Index pulse
 - Velocity-timer expiration
 - Direction change
 - Quadrature error detection

1.3.11 Analog

The TM4C129ENCPDT microcontroller provides analog functions integrated into the device, including:

- Two 12-bit Analog-to-Digital Converters (ADC), with a total of 20 analog input channels and each with a sample rate of two million samples/second
- Three analog comparators
- On-chip voltage regulator

The following provides more detail on these analog functions.

1.3.11.1 ADC (see page 1177)

An analog-to-digital converter (ADC) is a peripheral that converts a continuous analog voltage to a discrete digital number. The TM4C129ENCPDT ADC module features 12-bit conversion resolution and supports 20 input channels plus an internal temperature sensor. Four buffered sample sequencers allow rapid sampling of up to 20 analog input sources without controller intervention. Each sample sequencer provides flexible programming with fully configurable input source, trigger events, interrupt generation, and sequencer priority. Each ADC module has a digital comparator function that allows the conversion value to be diverted to a comparison unit that provides eight digital comparators.

The TM4C129ENCPDT microcontroller provides two ADC modules, each with the following features:

- 20 shared analog input channels
- 12-bit precision ADC
- Single-ended and differential-input configurations
- On-chip internal temperature sensor
- Maximum sample rate of two million samples/second
- Optional, programmable phase delay
- Sample and hold window programmability
- Four programmable sample conversion sequencers from one to eight entries long, with corresponding conversion result FIFOs
- Flexible trigger control
 - Controller (software)
 - Timers
 - Analog Comparators
 - PWM
 - GPIO
- Hardware averaging of up to 64 samples

- Eight digital comparators
- Converter uses signals VREFA+ and GNDA as the voltage reference
- Power and ground for the analog circuitry is separate from the digital power and ground
- Efficient transfers using Micro Direct Memory Access Controller (μDMA)
 - Dedicated channel for each sample sequencer
 - ADC module uses burst requests for DMA
- Global Alternate Clock (ALTCLK) resource or System Clock (SYSCLK) can be used to generate ADC clock

1.3.11.2 Analog Comparators (see page 1777)

An analog comparator is a peripheral that compares two analog voltages and provides a logical output that signals the comparison result. The TM4C129ENCPDT microcontroller provides three independent integrated analog comparators that can be configured to drive an output or generate an interrupt or ADC event.

The comparator can provide its output to a device pin, acting as a replacement for an analog comparator on the board, or it can be used to signal the application via interrupts or triggers to the ADC to cause it to start capturing a sample sequence. The interrupt generation and ADC triggering logic is separate. This means, for example, that an interrupt can be generated on a rising edge and the ADC triggered on a falling edge.

The TM4C129ENCPDT microcontroller provides three independent integrated analog comparators with the following functions:

- Compare external pin input to external pin input or to internal programmable voltage reference
- Compare a test voltage against any one of the following voltages:
 - An individual external reference voltage
 - A shared single external reference voltage
 - A shared internal reference voltage

1.3.12 JTAG and ARM Serial Wire Debug (see page 214)

The Joint Test Action Group (JTAG) port is an IEEE standard that defines a Test Access Port and Boundary Scan Architecture for digital integrated circuits and provides a standardized serial interface for controlling the associated test logic. The TAP, Instruction Register (IR), and Data Registers (DR) can be used to test the interconnections of assembled printed circuit boards and obtain manufacturing information on the components. The JTAG Port also provides a means of accessing and controlling design-for-test features such as I/O pin observation and control, scan testing, and debugging. Texas Instruments replaces the ARM SW-DP and JTAG-DP with the ARM Serial Wire JTAG Debug Port (SWJ-DP) interface. The SWJ-DP interface combines the SWD and JTAG debug ports into one module providing all the normal JTAG debug and test functionality plus real-time access to system memory without halting the core or requiring any target resident code. The SWJ-DP interface has the following features:

- IEEE 1149.1-1990 compatible Test Access Port (TAP) controller

- Four-bit Instruction Register (IR) chain for storing JTAG instructions
- IEEE standard instructions: BYPASS, IDCODE, SAMPLE/PRELOAD, and EXTEST
- ARM additional instructions: APACC, DPACC and ABORT
- Integrated ARM Serial Wire Debug (SWD)
 - Serial Wire JTAG Debug Port (SWJ-DP)
 - Flash Patch and Breakpoint (FPB) unit for implementing breakpoints
 - Data Watchpoint and Trace (DWT) unit for implementing watchpoints, trigger resources, and system profiling
 - Instrumentation Trace Macrocell (ITM) for support of printf style debugging
 - Embedded Trace Macrocell (ETM) for instruction trace capture
 - Trace Port Interface Unit (TPIU) for bridging to a Trace Port Analyzer

1.3.13 Packaging and Temperature

- 128-pin RoHS-compliant TQFP package
- Industrial (-40°C to 85°C) ambient temperature range
- Extended (-40°C to 105°C) ambient temperature range

1.4 TM4C129ENCPDT Microcontroller Hardware Details

Details on the pins and package can be found in the following sections:

- “Pin Diagram” on page 1895
- “Signal Tables” on page 1896
- “Electrical Characteristics” on page 1942
- “Package Information” on page 2009

1.5 Kits

The Tiva™ C Series provides the hardware and software tools that engineers need to begin development quickly.

- Reference Design Kits accelerate product development by providing ready-to-run hardware and comprehensive documentation including hardware design files
- Evaluation Kits provide a low-cost and effective means of evaluating TM4C129ENCPDT microcontrollers before purchase
- Development Kits provide you with all the tools you need to develop and prototype embedded applications right out of the box

See the Tiva series website at <http://www.ti.com/tiva-c> for the latest tools available, or ask your distributor.

1.6 Support Information

For support on Tiva™ C Series products, contact the [TI Worldwide Product Information Center](#) nearest you.

2 The Cortex-M4F Processor

The ARM® Cortex™-M4F processor provides a high-performance, low-cost platform that meets the system requirements of minimal memory implementation, reduced pin count, and low power consumption, while delivering outstanding computational performance and exceptional system response to interrupts. Features include:

- 32-bit ARM® Cortex™-M4F architecture optimized for small-footprint embedded applications
- 120-MHz operation; 150 DMIPS performance
- Outstanding processing performance combined with fast interrupt handling
- Thumb-2 mixed 16-/32-bit instruction set delivers the high performance expected of a 32-bit ARM core in a compact memory size usually associated with 8- and 16-bit devices, typically in the range of a few kilobytes of memory for microcontroller-class applications
 - Single-cycle multiply instruction and hardware divide
 - Atomic bit manipulation (bit-banding), delivering maximum memory utilization and streamlined peripheral control
 - Unaligned data access, enabling data to be efficiently packed into memory
- IEEE754-compliant single-precision Floating-Point Unit (FPU)
- 16-bit SIMD vector processing unit
- Fast code execution permits slower processor clock or increases sleep mode time
- Harvard architecture characterized by separate buses for instruction and data
- Efficient processor core, system and memories
- Hardware division and fast digital-signal-processing orientated multiply accumulate
- Saturating arithmetic for signal processing
- Deterministic, high-performance interrupt handling for time-critical applications
- Memory protection unit (MPU) to provide a privileged mode for protected operating system functionality
- Enhanced system debug with extensive breakpoint and trace capabilities
- Serial Wire Debug and Serial Wire Trace reduce the number of pins required for debugging and tracing
- Migration from the ARM7™ processor family for better performance and power efficiency
- Optimized for single-cycle Flash memory usage up to specific frequencies; see “Internal Memory” on page 608 for more information.
- Ultra-low power consumption with integrated sleep modes

The Tiva™ C Series microcontrollers builds on this core to bring high-performance 32-bit computing to cost-conscious applications requiring significant control processing and connectivity capabilities such as:

- Low power, hand-held smart devices
- Gaming equipment
- Network appliances and switches
- Home and commercial site monitoring and control
- Electronic point-of-sale (POS) machines
- Motion control
- Medical instrumentation
- Remote connectivity and monitoring
- Test and measurement equipment
- Factory automation
- Fire and security
- Smart Energy/Smart Grid solutions
- Intelligent lighting control
- Transportation

This chapter provides information on the Tiva™ C Series implementation of the Cortex-M4F processor, including the programming model, the memory model, the exception model, fault handling, and power management.

For technical details on the instruction set, see the Cortex™-M4 instruction set chapter in the *ARM® Cortex™-M4 Devices Generic User Guide* (literature number [ARM DUI 0553A](#)).

2.1 Block Diagram

The Cortex-M4F processor is built on a high-performance processor core, with a 3-stage pipeline Harvard architecture, making it ideal for demanding embedded applications. The processor delivers exceptional power efficiency through an efficient instruction set and extensively optimized design, providing high-end processing hardware including IEEE754-compliant single-precision floating-point computation, a range of single-cycle and SIMD multiplication and multiply-with-accumulate capabilities, saturating arithmetic and dedicated hardware division.

To facilitate the design of cost-sensitive devices, the Cortex-M4F processor implements tightly coupled system components that reduce processor area while significantly improving interrupt handling and system debug capabilities. The Cortex-M4F processor implements a version of the Thumb® instruction set based on Thumb-2 technology, ensuring high code density and reduced program memory requirements. The Cortex-M4F instruction set provides the exceptional performance expected of a modern 32-bit architecture, with the high code density of 8-bit and 16-bit microcontrollers.

The Cortex-M4F processor closely integrates a nested interrupt controller (NVIC), to deliver industry-leading interrupt performance. The TM4C129ENCPDT NVIC includes a non-maskable interrupt (NMI) and provides eight interrupt priority levels. The tight integration of the processor core and NVIC provides fast execution of interrupt service routines (ISRs), dramatically reducing interrupt latency. The hardware stacking of registers and the ability to suspend load-multiple and store-multiple operations further reduce interrupt latency. Interrupt handlers do not require any assembler stubs which removes code overhead from the ISRs. Tail-chaining optimization also significantly reduces the overhead when switching from one ISR to another. To optimize low-power designs, the NVIC integrates with the sleep modes, including Deep-sleep mode, which enables the entire device to be rapidly powered down.

Figure 2-1. CPU Block Diagram

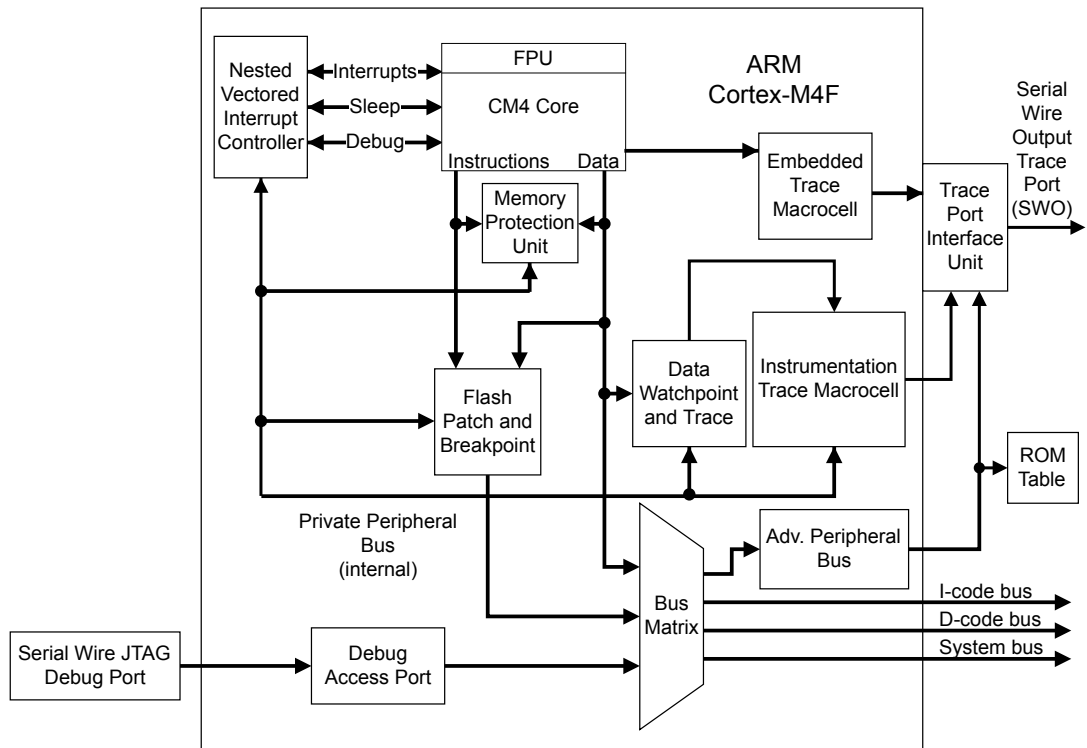

2.2 Overview

2.2.1 System-Level Interface

The Cortex-M4F processor provides multiple interfaces using AMBA® technology to provide high-speed, low-latency memory accesses. The core supports unaligned data accesses and implements atomic bit manipulation that enables faster peripheral controls, system spinlocks, and thread-safe Boolean data handling.

The Cortex-M4F processor has a memory protection unit (MPU) that provides fine-grain memory control, enabling applications to implement security privilege levels and separate code, data and stack on a task-by-task basis.

2.2.2 Integrated Configurable Debug

The Cortex-M4F processor implements a complete hardware debug solution, providing high system visibility of the processor and memory through either a traditional JTAG port or a 2-pin Serial Wire Debug (SWD) port that is ideal for microcontrollers and other small package devices. The Tiva™ C Series implementation replaces the ARM SW-DP and JTAG-DP with the ARM CoreSight™-compliant Serial Wire JTAG Debug Port (SWJ-DP) interface. The SWJ-DP interface combines the SWD and JTAG debug ports into one module. See the *ARM® Debug Interface V5 Architecture Specification* for details on SWJ-DP.

For system trace, the processor integrates an Instrumentation Trace Macrocell (ITM) alongside data watchpoints and a profiling unit. To enable simple and cost-effective profiling of the system trace events, a Serial Wire Viewer (SWV) can export a stream of software-generated messages, data trace, and profiling information through a single pin.

The Embedded Trace Macrocell (ETM) delivers unrivaled instruction trace capture in an area smaller than traditional trace units, enabling full instruction trace. For more details on the ARM ETM, see the *ARM® Embedded Trace Macrocell Architecture Specification*.

The Flash Patch and Breakpoint Unit (FPB) provides up to eight hardware breakpoint comparators that debuggers can use. The comparators in the FPB also provide remap functions for up to eight words of program code in the code memory region. This FPB enables applications stored in a read-only area of Flash memory to be patched in another area of on-chip SRAM or Flash memory. If a patch is required, the application programs the FPB to remap a number of addresses. When those addresses are accessed, the accesses are redirected to a remap table specified in the FPB configuration.

For more information on the Cortex-M4F debug capabilities, see the *ARM® Debug Interface V5 Architecture Specification*.

2.2.3 Trace Port Interface Unit (TPIU)

The TPIU acts as a bridge between the Cortex-M4F trace data from the ITM, and an off-chip Trace Port Analyzer, as shown in Figure 2-2 on page 89.

Figure 2-2. TPIU Block Diagram



2.2.4 Cortex-M4F System Component Details

The Cortex-M4F includes the following system components:

- SysTick

A 24-bit count-down timer that can be used as a Real-Time Operating System (RTOS) tick timer or as a simple counter (see “System Timer (SysTick)” on page 142).

- Nested Vectored Interrupt Controller (NVIC)

An embedded interrupt controller that supports low latency interrupt processing (see “Nested Vectored Interrupt Controller (NVIC)” on page 143).

- System Control Block (SCB)

The programming model interface to the processor. The SCB provides system implementation information and system control, including configuration, control, and reporting of system exceptions (see “System Control Block (SCB)” on page 144).

- Memory Protection Unit (MPU)

Improves system reliability by defining the memory attributes for different memory regions. The MPU provides up to eight different regions and an optional predefined background region (see “Memory Protection Unit (MPU)” on page 144).

- Floating-Point Unit (FPU)

Fully supports single-precision add, subtract, multiply, divide, multiply and accumulate, and square-root operations. It also provides conversions between fixed-point and floating-point data formats, and floating-point constant instructions (see “Floating-Point Unit (FPU)” on page 149).

2.3 Programming Model

This section describes the Cortex-M4F programming model. In addition to the individual core register descriptions, information about the processor modes and privilege levels for software execution and stacks is included.

2.3.1 Processor Mode and Privilege Levels for Software Execution

The Cortex-M4F has two modes of operation:

- Thread mode

Used to execute application software. The processor enters Thread mode when it comes out of reset.

- Handler mode

Used to handle exceptions. When the processor has finished exception processing, it returns to Thread mode.

In addition, the Cortex-M4F has two privilege levels:

- Unprivileged

In this mode, software has the following restrictions:

- Limited access to the `MSR` and `MRS` instructions and no use of the `CPS` instruction
- No access to the system timer, NVIC, or system control block
- Possibly restricted access to memory or peripherals

- Privileged

In this mode, software can use all the instructions and has access to all resources.

In Thread mode, the **CONTROL** register (see page 105) controls whether software execution is privileged or unprivileged. In Handler mode, software execution is always privileged.

Only privileged software can write to the **CONTROL** register to change the privilege level for software execution in Thread mode. Unprivileged software can use the `SVC` instruction to make a supervisor call to transfer control to privileged software.

2.3.2 Stacks

The processor uses a full descending stack, meaning that the stack pointer indicates the last stacked item on the memory. When the processor pushes a new item onto the stack, it decrements the stack pointer and then writes the item to the new memory location. The processor implements two stacks: the main stack and the process stack, with a pointer for each held in independent registers (see the **SP** register on page 95).

In Thread mode, the **CONTROL** register (see page 105) controls whether the processor uses the main stack or the process stack. In Handler mode, the processor always uses the main stack. The options for processor operations are shown in Table 2-1 on page 91.

Table 2-1. Summary of Processor Mode, Privilege Level, and Stack Use

Processor Mode	Use	Privilege Level	Stack Used
Thread	Applications	Privileged or unprivileged ^a	Main stack or process stack ^a
Handler	Exception handlers	Always privileged	Main stack

a. See **CONTROL** (page 105).

2.3.3 Register Map

Figure 2-3 on page 92 shows the Cortex-M4F register set. Table 2-2 on page 92 lists the Core registers. The core registers are not memory mapped and are accessed by register name, so the base address is n/a (not applicable) and there is no offset.

Figure 2-3. Cortex-M4F Register Set

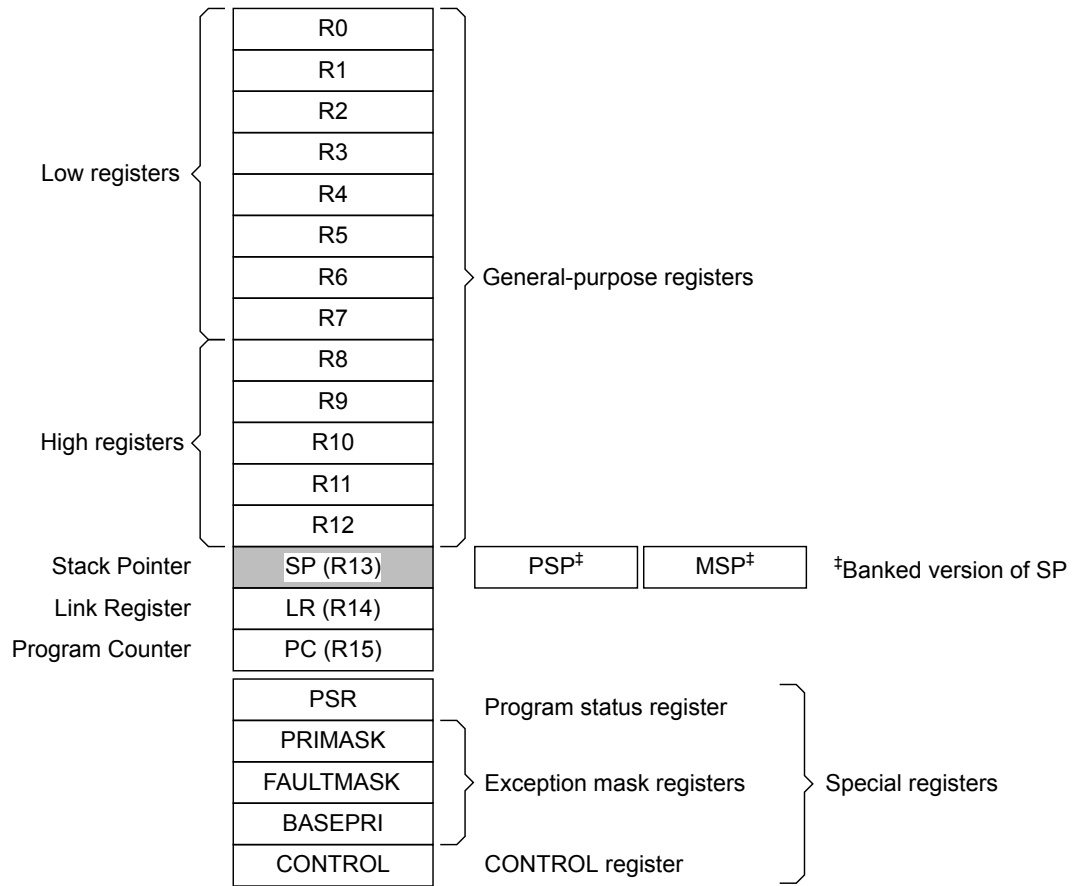

Table 2-2. Processor Register Map

Offset	Name	Type	Reset	Description	See page
-	R0	RW	-	Cortex General-Purpose Register 0	94
-	R1	RW	-	Cortex General-Purpose Register 1	94
-	R2	RW	-	Cortex General-Purpose Register 2	94
-	R3	RW	-	Cortex General-Purpose Register 3	94
-	R4	RW	-	Cortex General-Purpose Register 4	94
-	R5	RW	-	Cortex General-Purpose Register 5	94
-	R6	RW	-	Cortex General-Purpose Register 6	94
-	R7	RW	-	Cortex General-Purpose Register 7	94
-	R8	RW	-	Cortex General-Purpose Register 8	94
-	R9	RW	-	Cortex General-Purpose Register 9	94
-	R10	RW	-	Cortex General-Purpose Register 10	94
-	R11	RW	-	Cortex General-Purpose Register 11	94

Table 2-2. Processor Register Map (continued)

Offset	Name	Type	Reset	Description	See page
-	R12	RW	-	Cortex General-Purpose Register 12	94
-	SP	RW	-	Stack Pointer	95
-	LR	RW	0xFFFF.FFFF	Link Register	96
-	PC	RW	-	Program Counter	97
-	PSR	RW	0x0100.0000	Program Status Register	98
-	PRIMASK	RW	0x0000.0000	Priority Mask Register	102
-	FAULTMASK	RW	0x0000.0000	Fault Mask Register	103
-	BASEPRI	RW	0x0000.0000	Base Priority Mask Register	104
-	CONTROL	RW	0x0000.0000	Control Register	105
-	FPSC	RW	-	Floating-Point Status Control	107

2.3.4 Register Descriptions

This section lists and describes the Cortex-M4F registers, in the order shown in Figure 2-3 on page 92. The core registers are not memory mapped and are accessed by register name rather than offset.

Note: The register type shown in the register descriptions refers to type during program execution in Thread mode and Handler mode. Debug access can differ.

- Register 1: Cortex General-Purpose Register 0 (R0)**
- Register 2: Cortex General-Purpose Register 1 (R1)**
- Register 3: Cortex General-Purpose Register 2 (R2)**
- Register 4: Cortex General-Purpose Register 3 (R3)**
- Register 5: Cortex General-Purpose Register 4 (R4)**
- Register 6: Cortex General-Purpose Register 5 (R5)**
- Register 7: Cortex General-Purpose Register 6 (R6)**
- Register 8: Cortex General-Purpose Register 7 (R7)**
- Register 9: Cortex General-Purpose Register 8 (R8)**
- Register 10: Cortex General-Purpose Register 9 (R9)**
- Register 11: Cortex General-Purpose Register 10 (R10)**
- Register 12: Cortex General-Purpose Register 11 (R11)**
- Register 13: Cortex General-Purpose Register 12 (R12)**

The **Rn** registers are 32-bit general-purpose registers for data operations and can be accessed from either privileged or unprivileged mode.

Cortex General-Purpose Register 0 (R0)

Type RW, reset -



Bit/Field	Name	Type	Reset	Description
31:0	DATA	RW	-	Register data.

Register 14: Stack Pointer (SP)

The **Stack Pointer (SP)** is register R13. In Thread mode, the function of this register changes depending on the `ASP` bit in the **Control Register (CONTROL)** register. When the `ASP` bit is clear, this register is the **Main Stack Pointer (MSP)**. When the `ASP` bit is set, this register is the **Process Stack Pointer (PSP)**. On reset, the `ASP` bit is clear, and the processor loads the **MSP** with the value from address 0x0000.0000. The **MSP** can only be accessed in privileged mode; the **PSP** can be accessed in either privileged or unprivileged mode.

Stack Pointer (SP)

Type RW, reset -

	31	30	29	28	27	26	25	24	23	22	21	20	19	18	17	16
	SP															
Type	RW	RW	RW	RW	RW	RW	RW	RW	RW	RW	RW	RW	RW	RW	RW	RW
Reset	-	-	-	-	-	-	-	-	-	-	-	-	-	-	-	-
	15	14	13	12	11	10	9	8	7	6	5	4	3	2	1	0
	SP															
Type	RW	RW	RW	RW	RW	RW	RW	RW	RW	RW	RW	RW	RW	RW	RW	RW
Reset	-	-	-	-	-	-	-	-	-	-	-	-	-	-	-	-

Bit/Field	Name	Type	Reset	Description
31:0	SP	RW	-	This field is the address of the stack pointer.

Register 15: Link Register (LR)

The **Link Register (LR)** is register R14, and it stores the return information for subroutines, function calls, and exceptions. The Link Register can be accessed from either privileged or unprivileged mode.

EXC_RETURN is loaded into the **LR** on exception entry. See Table 2-10 on page 130 for the values and description.

Link Register (LR)

Type RW, reset 0xFFFF.FFFF



Bit/Field	Name	Type	Reset	Description
31:0	LINK	RW	0xFFFF.FFFF	This field is the return address.

Register 16: Program Counter (PC)

The **Program Counter (PC)** is register R15, and it contains the current program address. On reset, the processor loads the **PC** with the value of the reset vector, which is at address 0x0000.0004. Bit 0 of the reset vector is loaded into the **THUMB** bit of the **EPSR** at reset and must be 1. The **PC** register can be accessed in either privileged or unprivileged mode.

Program Counter (PC)

Type RW, reset -

	31	30	29	28	27	26	25	24	23	22	21	20	19	18	17	16
	PC															
Type	RW	RW	RW	RW	RW	RW	RW	RW	RW	RW	RW	RW	RW	RW	RW	RW
Reset	-	-	-	-	-	-	-	-	-	-	-	-	-	-	-	-
	15	14	13	12	11	10	9	8	7	6	5	4	3	2	1	0
	PC															
Type	RW	RW	RW	RW	RW	RW	RW	RW	RW	RW	RW	RW	RW	RW	RW	RW
Reset	-	-	-	-	-	-	-	-	-	-	-	-	-	-	-	-

Bit/Field	Name	Type	Reset	Description
31:0	PC	RW	-	This field is the current program address.

Register 17: Program Status Register (PSR)

Note: This register is also referred to as **xPSR**.

The **Program Status Register (PSR)** has three functions, and the register bits are assigned to the different functions:

- **Application Program Status Register (APSR)**, bits 31:27, bits 19:16
- **Execution Program Status Register (EPSR)**, bits 26:24, 15:10
- **Interrupt Program Status Register (IPSR)**, bits 7:0

The **PSR**, **IPSR**, and **EPSR** registers can only be accessed in privileged mode; the **APSR** register can be accessed in either privileged or unprivileged mode.

APSR contains the current state of the condition flags from previous instruction executions.

EPSR contains the Thumb state bit and the execution state bits for the If-Then (**IT**) instruction or the Interruptible-Continuable Instruction (**ICI**) field for an interrupted load multiple or store multiple instruction. Attempts to read the **EPSR** directly through application software using the **MSR** instruction always return zero. Attempts to write the **EPSR** using the **MSR** instruction in application software are always ignored. Fault handlers can examine the **EPSR** value in the stacked **PSR** to determine the operation that faulted (see “Exception Entry and Return” on page 127).

IPSR contains the exception type number of the current Interrupt Service Routine (**ISR**).

These registers can be accessed individually or as a combination of any two or all three registers, using the register name as an argument to the **MSR** or **MRS** instructions. For example, all of the registers can be read using **PSR** with the **MRS** instruction, or **APSR** only can be written to using **APSR** with the **MSR** instruction. page 98 shows the possible register combinations for the **PSR**. See the **MRS** and **MSR** instruction descriptions in the Cortex™-M4 instruction set chapter in the *ARM® Cortex™-M4 Devices Generic User Guide (literature number ARM DUI 0553A)* for more information about how to access the program status registers.

Table 2-3. PSR Register Combinations

Register	Type	Combination
PSR	RW ^{a, b}	APSR , EPSR , and IPSR
IEPSR	RO	EPSR and IPSR
IAPSR	RW ^a	APSR and IPSR
EAPSR	RW ^b	APSR and EPSR

a. The processor ignores writes to the **IPSR** bits.

b. Reads of the **EPSR** bits return zero, and the processor ignores writes to these bits.

Program Status Register (PSR)

Type RW, reset 0x0100.0000

	31	30	29	28	27	26	25	24	23	22	21	20	19	18	17	16
	N	Z	C	V	Q	ICI / IT		THUMB	reserved				GE			
Type	RW	RW	RW	RW	RW	RO	RO	RO	RO	RO	RO	RO	RW	RW	RW	RW
Reset	0	0	0	0	0	0	0	1	0	0	0	0	0	0	0	0
	15	14	13	12	11	10	9	8	7	6	5	4	3	2	1	0
	ICI / IT				reserved				ISRNUM							
Type	RO	RO	RO	RO	RO	RO	RO	RO	RO	RO	RO	RO	RO	RO	RO	RO
Reset	0	0	0	0	0	0	0	0	0	0	0	0	0	0	0	0

Bit/Field	Name	Type	Reset	Description
31	N	RW	0	<p>APSR Negative or Less Flag</p> <p>Value Description</p> <p>1 The previous operation result was negative or less than.</p> <p>0 The previous operation result was positive, zero, greater than, or equal.</p> <p>The value of this bit is only meaningful when accessing PSR or APSR.</p>
30	Z	RW	0	<p>APSR Zero Flag</p> <p>Value Description</p> <p>1 The previous operation result was zero.</p> <p>0 The previous operation result was non-zero.</p> <p>The value of this bit is only meaningful when accessing PSR or APSR.</p>
29	C	RW	0	<p>APSR Carry or Borrow Flag</p> <p>Value Description</p> <p>1 The previous add operation resulted in a carry bit or the previous subtract operation did not result in a borrow bit.</p> <p>0 The previous add operation did not result in a carry bit or the previous subtract operation resulted in a borrow bit.</p> <p>The value of this bit is only meaningful when accessing PSR or APSR.</p>
28	V	RW	0	<p>APSR Overflow Flag</p> <p>Value Description</p> <p>1 The previous operation resulted in an overflow.</p> <p>0 The previous operation did not result in an overflow.</p> <p>The value of this bit is only meaningful when accessing PSR or APSR.</p>
27	Q	RW	0	<p>APSR DSP Overflow and Saturation Flag</p> <p>Value Description</p> <p>1 DSP Overflow or saturation has occurred when using a SIMD instruction.</p> <p>0 DSP overflow or saturation has not occurred since reset or since the bit was last cleared.</p> <p>The value of this bit is only meaningful when accessing PSR or APSR. This bit is cleared by software using an MRS instruction.</p>

Bit/Field	Name	Type	Reset	Description
26:25	ICI / IT	RO	0x0	<p>EPSR ICI / IT status</p> <p>These bits, along with bits 15:10, contain the Interruptible-Continuable Instruction (ICI) field for an interrupted load multiple or store multiple instruction or the execution state bits of the IT instruction.</p> <p>When EPSR holds the ICI execution state, bits 26:25 are zero.</p> <p>The If-Then block contains up to four instructions following an IT instruction. Each instruction in the block is conditional. The conditions for the instructions are either all the same, or some can be the inverse of others. See the Cortex™-M4 instruction set chapter in the <i>ARM® Cortex™-M4 Devices Generic User Guide (literature number ARM DUI 0553A)</i> for more information.</p> <p>The value of this field is only meaningful when accessing PSR or EPSR. Note that these EPSR bits cannot be accessed using MRS and MSR instructions but the definitions are provided to allow the stacked (E)PSR value to be decoded within an exception handler.</p>
24	THUMB	RO	1	<p>EPSR Thumb State</p> <p>This bit indicates the Thumb state and should always be set.</p> <p>The following can clear the THUMB bit:</p> <ul style="list-style-type: none"> ■ The BLX, BX and POP{PC} instructions ■ Restoration from the stacked xPSR value on an exception return ■ Bit 0 of the vector value on an exception entry or reset <p>Attempting to execute instructions when this bit is clear results in a fault or lockup. See "Lockup" on page 132 for more information.</p> <p>The value of this bit is only meaningful when accessing PSR or EPSR.</p>
23:20	reserved	RO	0x00	<p>Software should not rely on the value of a reserved bit. To provide compatibility with future products, the value of a reserved bit should be preserved across a read-modify-write operation.</p>
19:16	GE	RW	0x0	<p>Greater Than or Equal Flags</p> <p>See the description of the SEL instruction in the Cortex™-M4 instruction set chapter in the <i>ARM® Cortex™-M4 Devices Generic User Guide (literature number ARM DUI 0553A)</i> for more information.</p> <p>The value of this field is only meaningful when accessing PSR or APSR.</p>

Bit/Field	Name	Type	Reset	Description																																				
15:10	ICI / IT	RO	0x0	<p>EPSR ICI / IT status</p> <p>These bits, along with bits 26:25, contain the Interruptible-Continuable Instruction (ICI) field for an interrupted load multiple or store multiple instruction or the execution state bits of the IT instruction.</p> <p>When an interrupt occurs during the execution of an LDM, STM, PUSH POP, VLDM, VSTM, VPUSH, or VPOP instruction, the processor stops the load multiple or store multiple instruction operation temporarily and stores the next register operand in the multiple operation to bits 15:12. After servicing the interrupt, the processor returns to the register pointed to by bits 15:12 and resumes execution of the multiple load or store instruction. When EPSR holds the ICI execution state, bits 11:10 are zero.</p> <p>The If-Then block contains up to four instructions following a 16-bit IT instruction. Each instruction in the block is conditional. The conditions for the instructions are either all the same, or some can be the inverse of others. See the Cortex™-M4 instruction set chapter in the <i>ARM® Cortex™-M4 Devices Generic User Guide (literature number ARM DUI 0553A)</i> for more information.</p> <p>The value of this field is only meaningful when accessing PSR or EPSR.</p>																																				
9:8	reserved	RO	0x0	Software should not rely on the value of a reserved bit. To provide compatibility with future products, the value of a reserved bit should be preserved across a read-modify-write operation.																																				
7:0	ISRNUM	RO	0x00	<p>IPSR ISR Number</p> <p>This field contains the exception type number of the current Interrupt Service Routine (ISR).</p> <table border="1"> <thead> <tr> <th>Value</th> <th>Description</th> </tr> </thead> <tbody> <tr><td>0x00</td><td>Thread mode</td></tr> <tr><td>0x01</td><td>Reserved</td></tr> <tr><td>0x02</td><td>NMI</td></tr> <tr><td>0x03</td><td>Hard fault</td></tr> <tr><td>0x04</td><td>Memory management fault</td></tr> <tr><td>0x05</td><td>Bus fault</td></tr> <tr><td>0x06</td><td>Usage fault</td></tr> <tr><td>0x07-0x0A</td><td>Reserved</td></tr> <tr><td>0x0B</td><td>SVCcall</td></tr> <tr><td>0x0C</td><td>Reserved for Debug</td></tr> <tr><td>0x0D</td><td>Reserved</td></tr> <tr><td>0x0E</td><td>PendSV</td></tr> <tr><td>0x0F</td><td>SysTick</td></tr> <tr><td>0x10</td><td>Interrupt Vector 0</td></tr> <tr><td>0x11</td><td>Interrupt Vector 1</td></tr> <tr><td>...</td><td>...</td></tr> <tr><td>0x81</td><td>Interrupt Vector 113</td></tr> </tbody> </table> <p>See "Exception Types" on page 120 for more information.</p> <p>The value of this field is only meaningful when accessing PSR or IPSR.</p>	Value	Description	0x00	Thread mode	0x01	Reserved	0x02	NMI	0x03	Hard fault	0x04	Memory management fault	0x05	Bus fault	0x06	Usage fault	0x07-0x0A	Reserved	0x0B	SVCcall	0x0C	Reserved for Debug	0x0D	Reserved	0x0E	PendSV	0x0F	SysTick	0x10	Interrupt Vector 0	0x11	Interrupt Vector 1	0x81	Interrupt Vector 113
Value	Description																																							
0x00	Thread mode																																							
0x01	Reserved																																							
0x02	NMI																																							
0x03	Hard fault																																							
0x04	Memory management fault																																							
0x05	Bus fault																																							
0x06	Usage fault																																							
0x07-0x0A	Reserved																																							
0x0B	SVCcall																																							
0x0C	Reserved for Debug																																							
0x0D	Reserved																																							
0x0E	PendSV																																							
0x0F	SysTick																																							
0x10	Interrupt Vector 0																																							
0x11	Interrupt Vector 1																																							
...	...																																							
0x81	Interrupt Vector 113																																							

Register 18: Priority Mask Register (PRIMASK)

The **PRIMASK** register prevents activation of all exceptions with programmable priority. Reset, non-maskable interrupt (NMI), and hard fault are the only exceptions with fixed priority. Exceptions should be disabled when they might impact the timing of critical tasks. This register is only accessible in privileged mode. The **MSR** and **MRS** instructions are used to access the **PRIMASK** register, and the **CPS** instruction may be used to change the value of the **PRIMASK** register. See the Cortex™-M4 instruction set chapter in the *ARM® Cortex™-M4 Devices Generic User Guide (literature number ARM DUI 0553A)* for more information on these instructions. For more information on exception priority levels, see “Exception Types” on page 120.

Priority Mask Register (PRIMASK)

Type RW, reset 0x0000.0000

	31	30	29	28	27	26	25	24	23	22	21	20	19	18	17	16
	reserved															
Type	RO	RO	RO	RO	RO	RO	RO	RO	RO	RO	RO	RO	RO	RO	RO	RO
Reset	0	0	0	0	0	0	0	0	0	0	0	0	0	0	0	0
	15	14	13	12	11	10	9	8	7	6	5	4	3	2	1	0
	reserved															PRIMASK
Type	RO	RO	RO	RO	RO	RO	RO	RO	RO	RO	RO	RO	RO	RO	RO	RW
Reset	0	0	0	0	0	0	0	0	0	0	0	0	0	0	0	0

Bit/Field	Name	Type	Reset	Description
31:1	reserved	RO	0x0000.000	Software should not rely on the value of a reserved bit. To provide compatibility with future products, the value of a reserved bit should be preserved across a read-modify-write operation.
0	PRIMASK	RW	0	Priority Mask
				Value Description
				1 Prevents the activation of all exceptions with configurable priority.
				0 No effect.

Register 19: Fault Mask Register (FAULTMASK)

The **FAULTMASK** register prevents activation of all exceptions except for the Non-Maskable Interrupt (NMI). Exceptions should be disabled when they might impact the timing of critical tasks. This register is only accessible in privileged mode. The **MSR** and **MRS** instructions are used to access the **FAULTMASK** register, and the **CPS** instruction may be used to change the value of the **FAULTMASK** register. See the Cortex™-M4 instruction set chapter in the *ARM® Cortex™-M4 Devices Generic User Guide (literature number ARM DUI 0553A)* for more information on these instructions. For more information on exception priority levels, see “Exception Types” on page 120.

Fault Mask Register (FAULTMASK)

Type RW, reset 0x0000.0000

	31	30	29	28	27	26	25	24	23	22	21	20	19	18	17	16
	reserved															
Type	RO	RO	RO	RO	RO	RO	RO	RO	RO	RO	RO	RO	RO	RO	RO	RO
Reset	0	0	0	0	0	0	0	0	0	0	0	0	0	0	0	0
	15	14	13	12	11	10	9	8	7	6	5	4	3	2	1	0
	reserved															FAULTMASK
Type	RO	RO	RO	RO	RO	RO	RO	RO	RO	RO	RO	RO	RO	RO	RO	RW
Reset	0	0	0	0	0	0	0	0	0	0	0	0	0	0	0	0

Bit/Field	Name	Type	Reset	Description
31:1	reserved	RO	0x0000.000	Software should not rely on the value of a reserved bit. To provide compatibility with future products, the value of a reserved bit should be preserved across a read-modify-write operation.
0	FAULTMASK	RW	0	Fault Mask

Value Description

1	Prevents the activation of all exceptions except for NMI.
0	No effect.

The processor clears the **FAULTMASK** bit on exit from any exception handler except the NMI handler.

Register 20: Base Priority Mask Register (BASEPRI)

The **BASEPRI** register defines the minimum priority for exception processing. When **BASEPRI** is set to a nonzero value, it prevents the activation of all exceptions with the same or lower priority level as the **BASEPRI** value. Exceptions should be disabled when they might impact the timing of critical tasks. This register is only accessible in privileged mode. For more information on exception priority levels, see “Exception Types” on page 120.

Base Priority Mask Register (BASEPRI)

Type RW, reset 0x0000.0000

	31	30	29	28	27	26	25	24	23	22	21	20	19	18	17	16
	reserved															
Type	RO	RO	RO	RO	RO	RO	RO	RO	RO	RO	RO	RO	RO	RO	RO	RO
Reset	0	0	0	0	0	0	0	0	0	0	0	0	0	0	0	0
	15	14	13	12	11	10	9	8	7	6	5	4	3	2	1	0
	reserved								BASEPRI			reserved				
Type	RO	RO	RO	RO	RO	RO	RO	RO	RW	RW	RW	RO	RO	RO	RO	RO
Reset	0	0	0	0	0	0	0	0	0	0	0	0	0	0	0	0

Bit/Field	Name	Type	Reset	Description																		
31:8	reserved	RO	0x0000.00	Software should not rely on the value of a reserved bit. To provide compatibility with future products, the value of a reserved bit should be preserved across a read-modify-write operation.																		
7:5	BASEPRI	RW	0x0	<p>Base Priority</p> <p>Any exception that has a programmable priority level with the same or lower priority as the value of this field is masked. The PRIMASK register can be used to mask all exceptions with programmable priority levels. Higher priority exceptions have lower priority levels.</p> <table border="0"> <tr> <td>Value</td> <td>Description</td> </tr> <tr> <td>0x0</td> <td>All exceptions are unmasked.</td> </tr> <tr> <td>0x1</td> <td>All exceptions with priority level 1-7 are masked.</td> </tr> <tr> <td>0x2</td> <td>All exceptions with priority level 2-7 are masked.</td> </tr> <tr> <td>0x3</td> <td>All exceptions with priority level 3-7 are masked.</td> </tr> <tr> <td>0x4</td> <td>All exceptions with priority level 4-7 are masked.</td> </tr> <tr> <td>0x5</td> <td>All exceptions with priority level 5-7 are masked.</td> </tr> <tr> <td>0x6</td> <td>All exceptions with priority level 6-7 are masked.</td> </tr> <tr> <td>0x7</td> <td>All exceptions with priority level 7 are masked.</td> </tr> </table>	Value	Description	0x0	All exceptions are unmasked.	0x1	All exceptions with priority level 1-7 are masked.	0x2	All exceptions with priority level 2-7 are masked.	0x3	All exceptions with priority level 3-7 are masked.	0x4	All exceptions with priority level 4-7 are masked.	0x5	All exceptions with priority level 5-7 are masked.	0x6	All exceptions with priority level 6-7 are masked.	0x7	All exceptions with priority level 7 are masked.
Value	Description																					
0x0	All exceptions are unmasked.																					
0x1	All exceptions with priority level 1-7 are masked.																					
0x2	All exceptions with priority level 2-7 are masked.																					
0x3	All exceptions with priority level 3-7 are masked.																					
0x4	All exceptions with priority level 4-7 are masked.																					
0x5	All exceptions with priority level 5-7 are masked.																					
0x6	All exceptions with priority level 6-7 are masked.																					
0x7	All exceptions with priority level 7 are masked.																					
4:0	reserved	RO	0x0	Software should not rely on the value of a reserved bit. To provide compatibility with future products, the value of a reserved bit should be preserved across a read-modify-write operation.																		

Register 21: Control Register (CONTROL)

The **CONTROL** register controls the stack used and the privilege level for software execution when the processor is in Thread mode, and indicates whether the FPU state is active. This register is only accessible in privileged mode.

Handler mode always uses the **MSP**, so the processor ignores explicit writes to the **ASP** bit of the **CONTROL** register when in Handler mode. The exception entry and return mechanisms automatically update the **CONTROL** register based on the **EXC_RETURN** value (see Table 2-10 on page 130). In an OS environment, threads running in Thread mode should use the process stack and the kernel and exception handlers should use the main stack. By default, Thread mode uses the **MSP**. To switch the stack pointer used in Thread mode to the **PSP**, either use the **MSR** instruction to set the **ASP** bit, as detailed in the Cortex™-M4 instruction set chapter in the *ARM® Cortex™-M4 Devices Generic User Guide (literature number ARM DUI 0553A)*, or perform an exception return to Thread mode with the appropriate **EXC_RETURN** value, as shown in Table 2-10 on page 130.

Note: When changing the stack pointer, software must use an **ISB** instruction immediately after the **MSR** instruction, ensuring that instructions after the **ISB** execute use the new stack pointer. See the Cortex™-M4 instruction set chapter in the *ARM® Cortex™-M4 Devices Generic User Guide (literature number ARM DUI 0553A)*.

Control Register (CONTROL)

Type RW, reset 0x0000.0000

	31	30	29	28	27	26	25	24	23	22	21	20	19	18	17	16
	reserved															
Type	RO	RO	RO	RO	RO	RO	RO	RO	RO	RO	RO	RO	RO	RO	RO	RO
Reset	0	0	0	0	0	0	0	0	0	0	0	0	0	0	0	0
	15	14	13	12	11	10	9	8	7	6	5	4	3	2	1	0
	reserved													FPCA	ASP	TMPL
Type	RO	RO	RO	RO	RO	RO	RO	RO	RO	RO	RO	RO	RO	RW	RW	RW
Reset	0	0	0	0	0	0	0	0	0	0	0	0	0	0	0	0

Bit/Field	Name	Type	Reset	Description
31:3	reserved	RO	0x0000.000	Software should not rely on the value of a reserved bit. To provide compatibility with future products, the value of a reserved bit should be preserved across a read-modify-write operation.
2	FPCA	RW	0	Floating-Point Context Active
				Value Description
				1 Floating-point context active
				0 No floating-point context active

The Cortex-M4F uses this bit to determine whether to preserve floating-point state when processing an exception.

Important: Two bits control when **FPCA** can be enabled: the **ASPEN** bit in the **Floating-Point Context Control (FPCC)** register and the **DISFPCA** bit in the **Auxiliary Control (ACTLR)** register.

Bit/Field	Name	Type	Reset	Description
1	ASP	RW	0	Active Stack Pointer Value Description 1 The PSP is the current stack pointer. 0 The MSP is the current stack pointer In Handler mode, this bit reads as zero and ignores writes. The Cortex-M4F updates this bit automatically on exception return.
0	TMPL	RW	0	Thread Mode Privilege Level Value Description 1 Unprivileged software can be executed in Thread mode. 0 Only privileged software can be executed in Thread mode.

Register 22: Floating-Point Status Control (FPSC)

The **FPSC** register provides all necessary user-level control of the floating-point system.

Floating-Point Status Control (FPSC)

Type RW, reset -

	31	30	29	28	27	26	25	24	23	22	21	20	19	18	17	16
	N	Z	C	V	reserved	AHP	DN	FZ	RMODE		reserved					
Type	RW	RW	RW	RW	RO	RW	RW	RW	RW	RW	RO	RO	RO	RO	RO	RO
Reset	-	-	-	-	0	-	-	-	-	-	0	0	0	0	0	0
	15	14	13	12	11	10	9	8	7	6	5	4	3	2	1	0
	reserved								IDC	reserved		IXC	UFC	OFC	DZC	IOC
Type	RO	RO	RO	RO	RO	RO	RO	RO	RW	RO	RO	RW	RW	RW	RW	RW
Reset	0	0	0	0	0	0	0	0	-	0	0	-	-	-	-	-

Bit/Field	Name	Type	Reset	Description
31	N	RW	-	Negative Condition Code Flag Floating-point comparison operations update this condition code flag.
30	Z	RW	-	Zero Condition Code Flag Floating-point comparison operations update this condition code flag.
29	C	RW	-	Carry Condition Code Flag Floating-point comparison operations update this condition code flag.
28	V	RW	-	Overflow Condition Code Flag Floating-point comparison operations update this condition code flag.
27	reserved	RO	0	Software should not rely on the value of a reserved bit. To provide compatibility with future products, the value of a reserved bit should be preserved across a read-modify-write operation.
26	AHP	RW	-	Alternative Half-Precision When set, alternative half-precision format is selected. When clear, IEEE half-precision format is selected. The AHP bit in the FPDSC register holds the default value for this bit.
25	DN	RW	-	Default NaN Mode When set, any operation involving one or more NaNs returns the Default NaN. When clear, NaN operands propagate through to the output of a floating-point operation. The DN bit in the FPDSC register holds the default value for this bit.
24	FZ	RW	-	Flush-to-Zero Mode When set, Flush-to-Zero mode is enabled. When clear, Flush-to-Zero mode is disabled and the behavior of the floating-point system is fully compliant with the IEEE 754 standard. The FZ bit in the FPDSC register holds the default value for this bit.

Bit/Field	Name	Type	Reset	Description
23:22	RMODE	RW	-	<p>Rounding Mode</p> <p>The specified rounding mode is used by almost all floating-point instructions.</p> <p>The RMODE bit in the FPDSC register holds the default value for this bit.</p> <p>Value Description</p> <p>0x0 Round to Nearest (RN) mode</p> <p>0x1 Round towards Plus Infinity (RP) mode</p> <p>0x2 Round towards Minus Infinity (RM) mode</p> <p>0x3 Round towards Zero (RZ) mode</p>
21:8	reserved	RO	0x0	Software should not rely on the value of a reserved bit. To provide compatibility with future products, the value of a reserved bit should be preserved across a read-modify-write operation.
7	IDC	RW	-	<p>Input Denormal Cumulative Exception</p> <p>When set, indicates this exception has occurred since 0 was last written to this bit.</p>
6:5	reserved	RO	0x0	Software should not rely on the value of a reserved bit. To provide compatibility with future products, the value of a reserved bit should be preserved across a read-modify-write operation.
4	IXC	RW	-	<p>Inexact Cumulative Exception</p> <p>When set, indicates this exception has occurred since 0 was last written to this bit.</p>
3	UFC	RW	-	<p>Underflow Cumulative Exception</p> <p>When set, indicates this exception has occurred since 0 was last written to this bit.</p>
2	OFC	RW	-	<p>Overflow Cumulative Exception</p> <p>When set, indicates this exception has occurred since 0 was last written to this bit.</p>
1	DZC	RW	-	<p>Division by Zero Cumulative Exception</p> <p>When set, indicates this exception has occurred since 0 was last written to this bit.</p>
0	IOC	RW	-	<p>Invalid Operation Cumulative Exception</p> <p>When set, indicates this exception has occurred since 0 was last written to this bit.</p>

2.3.5 Exceptions and Interrupts

The Cortex-M4F processor supports interrupts and system exceptions. The processor and the Nested Vectored Interrupt Controller (NVIC) prioritize and handle all exceptions. An exception changes the normal flow of software control. The processor uses Handler mode to handle all exceptions except for reset. See “Exception Entry and Return” on page 127 for more information.

The NVIC registers control interrupt handling. See “Nested Vectored Interrupt Controller (NVIC)” on page 143 for more information.

2.3.6 Data Types

The Cortex-M4F supports 32-bit words, 16-bit halfwords, and 8-bit bytes. The processor also supports 64-bit data transfer instructions. All instruction and data memory accesses are little endian. See “Memory Regions, Types and Attributes” on page 112 for more information.

2.4 Memory Model

This section describes the processor memory map, the behavior of memory accesses, and the bit-banding features. The processor has a fixed memory map that provides up to 4 GB of addressable memory.

The memory map for the TM4C129ENCPDT controller is provided in Table 2-4 on page 109. In this manual, register addresses are given as a hexadecimal increment, relative to the module’s base address as shown in the memory map.

The regions for SRAM and peripherals include bit-band regions. Bit-banding provides atomic operations to bit data (see “Bit-Banding” on page 115).

The processor reserves regions of the Private peripheral bus (PPB) address range for core peripheral registers (see “Cortex-M4 Peripherals” on page 141).

Note: Within the memory map, attempts to read or write addresses in reserved spaces result in a bus fault. In addition, attempts to write addresses in the flash range also result in a bus fault.

Table 2-4. Memory Map

Start	End	Description	For details, see page ...
Memory			
0x0000.0000	0x000F.FFFF	On-chip Flash	629
0x0010.0000	0x01FF.FFFF	Reserved	-
0x0200.0000	0x02FF.FFFF	On-chip ROM (16 MB)	610
0x0300.0000	0x1FFF.FFFF	Reserved	-
0x2000.0000	0x2006.FFFF	Bit-banded on-chip SRAM	610
0x2007.0000	0x21FF.FFFF	Reserved	-
0x2200.0000	0x2234.FFFF	Bit-band alias of bit-banded on-chip SRAM starting at 0x2000.0000	610
0x2235.0000	0x3FFF.FFFF	Reserved	-
Peripherals			
0x4000.0000	0x4000.0FFF	Watchdog timer 0	1154
0x4000.1000	0x4000.1FFF	Watchdog timer 1	1154
0x4000.2000	0x4000.3FFF	Reserved	-

Table 2-4. Memory Map (continued)

Start	End	Description	For details, see page ...
0x4000.4000	0x4000.4FFF	GPIO Port A	763
0x4000.5000	0x4000.5FFF	GPIO Port B	763
0x4000.6000	0x4000.6FFF	GPIO Port C	763
0x4000.7000	0x4000.7FFF	GPIO Port D	763
0x4000.8000	0x4000.8FFF	SSI0	1367
0x4000.9000	0x4000.9FFF	SSI1	1367
0x4000.A000	0x4000.AFFF	SSI2	1367
0x4000.B000	0x4000.BFFF	SSI3	1367
0x4000.C000	0x4000.CFFF	UART0	1297
0x4000.D000	0x4000.DFFF	UART1	1297
0x4000.E000	0x4000.EFFF	UART2	1297
0x4000.F000	0x4000.FFFF	UART3	1297
0x4001.0000	0x4001.0FFF	UART4	1297
0x4001.1000	0x4001.1FFF	UART5	1297
0x4001.2000	0x4001.2FFF	UART6	1297
0x4001.3000	0x4001.3FFF	UART7	1297
0x4001.4000	0x4001.FFFF	Reserved	-
Peripherals			
0x4002.0000	0x4002.0FFF	I ² C 0	1423
0x4002.1000	0x4002.1FFF	I ² C 1	1423
0x4002.2000	0x4002.2FFF	I ² C 2	1423
0x4002.3000	0x4002.3FFF	I ² C 3	1423
0x4002.4000	0x4002.4FFF	GPIO Port E	763
0x4002.5000	0x4002.5FFF	GPIO Port F	763
0x4002.6000	0x4002.6FFF	GPIO Port G	763
0x4002.7000	0x4002.7FFF	GPIO Port H	763
0x4002.8000	0x4002.8FFF	PWM 0	1803
0x4002.9000	0x4002.BFFF	Reserved	-
0x4002.C000	0x4002.CFFF	QEIO	1877
0x4002.D000	0x4002.FFFF	Reserved	-
0x4003.0000	0x4003.0FFF	16/32-bit Timer 0	1098
0x4003.1000	0x4003.1FFF	16/32-bit Timer 1	1098
0x4003.2000	0x4003.2FFF	16/32-bit Timer 2	1098
0x4003.3000	0x4003.3FFF	16/32-bit Timer 3	1098
0x4003.4000	0x4003.4FFF	16/32-bit Timer 4	1098
0x4003.5000	0x4003.5FFF	16/32-bit Timer 5	1098
0x4003.6000	0x4003.7FFF	Reserved	-
0x4003.8000	0x4003.8FFF	ADC0	1197
0x4003.9000	0x4003.9FFF	ADC1	1197
0x4003.A000	0x4003.BFFF	Reserved	-
0x4003.C000	0x4003.CFFF	Analog Comparators	1783

Table 2-4. Memory Map (continued)

Start	End	Description	For details, see page ...
0x4003.D000	0x4003.DFFF	GPIO Port J	763
0x4003.E000	0x4003.FFFF	Reserved	-
0x4004.0000	0x4004.0FFF	CAN0 Controller	1499
0x4004.1000	0x4004.1FFF	CAN1 Controller	1499
0x4004.2000	0x4004.FFFF	Reserved	-
0x4005.0000	0x4005.0FFF	USB	1770
0x4005.1000	0x4005.7FFF	Reserved	-
0x4005.8000	0x4005.8FFF	GPIO Port A (AHB aperture)	763
0x4005.9000	0x4005.9FFF	GPIO Port B (AHB aperture)	763
0x4005.A000	0x4005.AFFF	GPIO Port C (AHB aperture)	763
0x4005.B000	0x4005.BFFF	GPIO Port D (AHB aperture)	763
0x4005.C000	0x4005.CFFF	GPIO Port E (AHB aperture)	763
0x4005.D000	0x4005.DFFF	GPIO Port F (AHB aperture)	763
0x4005.E000	0x4005.EFFF	GPIO Port G (AHB aperture)	763
0x4005.F000	0x4005.FFFF	GPIO Port H (AHB aperture)	763
0x4006.0000	0x4006.0FFF	GPIO Port J (AHB aperture)	763
0x4006.1000	0x4006.1FFF	GPIO Port K (AHB aperture)	763
0x4006.2000	0x4006.2FFF	GPIO Port L (AHB aperture)	763
0x4006.3000	0x4006.3FFF	GPIO Port M (AHB aperture)	763
0x4006.4000	0x4006.4FFF	GPIO Port N (AHB aperture)	763
0x4006.5000	0x4006.5FFF	GPIO Port P (AHB aperture)	763
0x4006.6000	0x4006.6FFF	GPIO Port Q (AHB aperture)	763
0x4006.7000	0x400A.EFFF	Reserved	-
0x400A.F000	0x400A.FFFF	EEPROM and Key Locker	629
0x400B.0000	0x400B.7FFF	Reserved	-
0x400B.8000	0x400B.8FFF	I ² C 8	1423
0x400B.9000	0x400B.9FFF	I ² C 9	1423
0x400B.A000	0x400B.FFFF	Reserved	-
0x400C.0000	0x400C.0FFF	I ² C 4	1423
0x400C.1000	0x400C.1FFF	I ² C 5	1423
0x400C.2000	0x400C.2FFF	I ² C 6	1423
0x400C.3000	0x400C.3FFF	I ² C 7	1423
0x400C.4000	0x400C.FFFF	Reserved	-
0x400D.0000	0x400D.0FFF	EPI 0	864
0x400D.1000	0x400D.FFFF	Reserved	-
0x400E.0000	0x400E.0FFF	16/32-bit Timer 6	1098
0x400E.1000	0x400E.1FFF	16/32-bit Timer 7	1098
0x400E.2000	0x400E.BFFF	Reserved	-
0x400E.C000	0x400E.CFFF	Ethernet Controller	1591
0x400E.D000	0x400F.8FFF	Reserved	-
0x400F.9000	0x400F.9FFF	System Exception Module	531

Table 2-4. Memory Map (continued)

Start	End	Description	For details, see page ...
0x400F.A000	0x400F.BFFF	Reserved	-
0x400F.C000	0x400F.CFFF	Hibernation Module	559
0x400F.D000	0x400F.DFFF	Flash memory control	629
0x400F.E000	0x400F.EFFF	System control	254
0x400F.F000	0x400F.FFFF	μDMA	709
0x4010.0000	0x41FF.FFFF	Reserved	-
0x4200.0000	0x43FF.FFFF	Bit-banded alias of 0x4000.0000 through 0x400F.FFFF	-
0x4400.0000	0x4402.FFFF	Reserved	-
0x4403.0000	0x4403.0FFF	CRC and Cryptographic Control Module	-
0x4403.1000	0x4403.1FFF	Reserved [4 kB]	-
0x4403.2000	0x4403.3FFF	Reserved [8 kB]	-
0x4403.4000	0x4403.5FFF	SHA/MD5	1058
0x4403.6000	0x4403.7FFF	AES	984
0x4403.8000	0x4403.9FFF	DES	1024
0x4403.A000	0x4403.EFFF	Reserved	-
0x4403.F000	0x4403.FFFF	Reserved [4 kB]	-
0x4404.0000	0x4404.FFFF	Reserved [64 kB]	-
0x4405.0000	0x4405.3FFF	Reserved	-
0x4405.4000	0x4405.4FFF	EPHY 0	1591
0x4405.5000	0x5FFF.FFFF	Reserved	-
0x6000.0000	0xDFFF.FFFF	EPI0 mapped peripheral and RAM	-
Private Peripheral Bus			
0xE000.0000	0xE000.0FFF	Instrumentation Trace Macrocell (ITM)	88
0xE000.1000	0xE000.1FFF	Data Watchpoint and Trace (DWT)	88
0xE000.2000	0xE000.2FFF	Flash Patch and Breakpoint (FPB)	88
0xE000.3000	0xE000.DFFF	Reserved	-
0xE000.E000	0xE000.EFFF	Cortex-M4F Peripherals (SysTick, NVIC, MPU, FPU and SCB)	153
0xE000.F000	0xE003.FFFF	Reserved	-
0xE004.0000	0xE004.0FFF	Trace Port Interface Unit (TPIU)	89
0xE004.1000	0xE004.1FFF	Embedded Trace Macrocell (ETM)	88
0xE004.2000	0xFFFF.FFFF	Reserved	-

2.4.1 Memory Regions, Types and Attributes

The memory map and the programming of the MPU split the memory map into regions. Each region has a defined memory type, and some regions have additional memory attributes. The memory type and attributes determine the behavior of accesses to the region.

The memory types are:

- Normal: The processor can re-order transactions for efficiency and perform speculative reads.
- Device: The processor preserves transaction order relative to other transactions to Device or Strongly Ordered memory.

- Strongly Ordered: The processor preserves transaction order relative to all other transactions.

The different ordering requirements for Device and Strongly Ordered memory mean that the memory system can buffer a write to Device memory but must not buffer a write to Strongly Ordered memory.

An additional memory attribute is Execute Never (XN), which means the processor prevents instruction accesses. A fault exception is generated only on execution of an instruction executed from an XN region.

2.4.2 Memory System Ordering of Memory Accesses

For most memory accesses caused by explicit memory access instructions, the memory system does not guarantee that the order in which the accesses complete matches the program order of the instructions, providing the order does not affect the behavior of the instruction sequence. Normally, if correct program execution depends on two memory accesses completing in program order, software must insert a memory barrier instruction between the memory access instructions (see “Software Ordering of Memory Accesses” on page 114).

However, the memory system does guarantee ordering of accesses to Device and Strongly Ordered memory. For two memory access instructions A1 and A2, if both A1 and A2 are accesses to either Device or Strongly Ordered memory, and if A1 occurs before A2 in program order, A1 is always observed before A2.

2.4.3 Behavior of Memory Accesses

Table 2-5 on page 113 shows the behavior of accesses to each region in the memory map. See “Memory Regions, Types and Attributes” on page 112 for more information on memory types and the XN attribute. Tiva™ C Series devices may have reserved memory areas within the address ranges shown below (refer to Table 2-4 on page 109 for more information).

Table 2-5. Memory Access Behavior

Address Range	Memory Region	Memory Type	Execute Never (XN)	Description
0x0000.0000 - 0x1FFF.FFFF	Code	Normal	-	This executable region is for program code. Data can also be stored here.
0x2000.0000 - 0x3FFF.FFFF	SRAM	Normal	-	This executable region is for data. Code can also be stored here. This region includes bit band and bit band alias areas (see Table 2-6 on page 115).
0x4000.0000 - 0x5FFF.FFFF	Peripheral	Device	XN	This region includes bit band and bit band alias areas (see Table 2-7 on page 115).
0x6000.0000 - 0x9FFF.FFFF	External RAM	Normal	-	This executable region is for data.
0xA000.0000 - 0xDFFF.FFFF	External device	Device	XN	This region is for external device memory.
0xE000.0000- 0xE00F.FFFF	Private peripheral bus	Strongly Ordered	XN	This region includes the NVIC, system timer, and system control block.
0xE010.0000- 0xFFFF.FFFF	Reserved	-	-	-

The Code, SRAM, and external RAM regions can hold programs. However, it is recommended that programs always use the Code region because the Cortex-M4F has separate buses that can perform instruction fetches and data accesses simultaneously.

The MPU can override the default memory access behavior described in this section. For more information, see “Memory Protection Unit (MPU)” on page 144.

The Cortex-M4F prefetches instructions ahead of execution and speculatively prefetches from branch target addresses.

2.4.4 Software Ordering of Memory Accesses

The order of instructions in the program flow does not always guarantee the order of the corresponding memory transactions for the following reasons:

- The processor can reorder some memory accesses to improve efficiency, providing this does not affect the behavior of the instruction sequence.
- The processor has multiple bus interfaces.
- Memory or devices in the memory map have different wait states.
- Some memory accesses are buffered or speculative.

“Memory System Ordering of Memory Accesses” on page 113 describes the cases where the memory system guarantees the order of memory accesses. Otherwise, if the order of memory accesses is critical, software must include memory barrier instructions to force that ordering. The Cortex-M4F has the following memory barrier instructions:

- The Data Memory Barrier (DMB) instruction ensures that outstanding memory transactions complete before subsequent memory transactions.
- The Data Synchronization Barrier (DSB) instruction ensures that outstanding memory transactions complete before subsequent instructions execute.
- The Instruction Synchronization Barrier (ISB) instruction ensures that the effect of all completed memory transactions is recognizable by subsequent instructions.

Memory barrier instructions can be used in the following situations:

- MPU programming
 - If the MPU settings are changed and the change must be effective on the very next instruction, use a DSB instruction to ensure the effect of the MPU takes place immediately at the end of context switching.
 - Use an ISB instruction to ensure the new MPU setting takes effect immediately after programming the MPU region or regions, if the MPU configuration code was accessed using a branch or call. If the MPU configuration code is entered using exception mechanisms, then an ISB instruction is not required.
- Vector table

If the program changes an entry in the vector table and then enables the corresponding exception, use a DMB instruction between the operations. The DMB instruction ensures that if the exception is taken immediately after being enabled, the processor uses the new exception vector.
- Self-modifying code

If a program contains self-modifying code, use an ISB instruction immediately after the code modification in the program. The ISB instruction ensures subsequent instruction execution uses the updated program.

- Memory map switching

If the system contains a memory map switching mechanism, use a DSB instruction after switching the memory map in the program. The DSB instruction ensures subsequent instruction execution uses the updated memory map.

- Dynamic exception priority change

When an exception priority has to change when the exception is pending or active, use DSB instructions after the change. The change then takes effect on completion of the DSB instruction.

Memory accesses to Strongly Ordered memory, such as the System Control Block, do not require the use of DMB instructions.

For more information on the memory barrier instructions, see the Cortex™-M4 instruction set chapter in the *ARM® Cortex™-M4 Devices Generic User Guide* (literature number [ARM DUI 0553A](#)).

2.4.5 Bit-Banding

A bit-band region maps each word in a bit-band alias region to a single bit in the bit-band region. The bit-band regions occupy the lowest 1 MB of the SRAM and peripheral memory regions. Accesses to the 32-MB SRAM alias region map to the 1-MB SRAM bit-band region, as shown in Table 2-6 on page 115. Accesses to the 32-MB peripheral alias region map to the 1-MB peripheral bit-band region, as shown in Table 2-7 on page 115. For the specific address range of the bit-band regions, see Table 2-4 on page 109.

Note: A word access to the SRAM or the peripheral bit-band alias region maps to a single bit in the SRAM or peripheral bit-band region.

A word access to a bit band address results in a word access to the underlying memory, and similarly for halfword and byte accesses. This allows bit band accesses to match the access requirements of the underlying peripheral.

Table 2-6. SRAM Memory Bit-Banding Regions

Address Range		Memory Region	Instruction and Data Accesses
Start	End		
0x2000.0000	0x2006.FFFF	SRAM bit-band region	Direct accesses to this memory range behave as SRAM memory accesses, but this region is also bit addressable through bit-band alias.
0x2200.0000	0x2234.FFFF	SRAM bit-band alias	Data accesses to this region are remapped to bit band region. A write operation is performed as read-modify-write. Instruction accesses are not remapped.

Table 2-7. Peripheral Memory Bit-Banding Regions

Address Range		Memory Region	Instruction and Data Accesses
Start	End		
0x4000.0000	0x400F.FFFF	Peripheral bit-band region	Direct accesses to this memory range behave as peripheral memory accesses, but this region is also bit addressable through bit-band alias.
0x4200.0000	0x43FF.FFFF	Peripheral bit-band alias	Data accesses to this region are remapped to bit band region. A write operation is performed as read-modify-write. Instruction accesses are not permitted.

The following formula shows how the alias region maps onto the bit-band region:

$$\text{bit_word_offset} = (\text{byte_offset} \times 32) + (\text{bit_number} \times 4)$$
$$\text{bit_word_addr} = \text{bit_band_base} + \text{bit_word_offset}$$

where:

bit_word_offset

The position of the target bit in the bit-band memory region.

bit_word_addr

The address of the word in the alias memory region that maps to the targeted bit.

bit_band_base

The starting address of the alias region.

byte_offset

The number of the byte in the bit-band region that contains the targeted bit.

bit_number

The bit position, 0-7, of the targeted bit.

Figure 2-4 on page 117 shows examples of bit-band mapping between the SRAM bit-band alias region and the SRAM bit-band region:

- The alias word at 0x23FF.FFE0 maps to bit 0 of the bit-band byte at 0x200F.FFFF:

$$0x23FF.FFE0 = 0x2200.0000 + (0x000F.FFFF * 32) + (0 * 4)$$

- The alias word at 0x23FF.FFFC maps to bit 7 of the bit-band byte at 0x200F.FFFF:

$$0x23FF.FFFC = 0x2200.0000 + (0x000F.FFFF * 32) + (7 * 4)$$

- The alias word at 0x2200.0000 maps to bit 0 of the bit-band byte at 0x2000.0000:

$$0x2200.0000 = 0x2200.0000 + (0 * 32) + (0 * 4)$$

- The alias word at 0x2200.001C maps to bit 7 of the bit-band byte at 0x2000.0000:

$$0x2200.001C = 0x2200.0000 + (0 * 32) + (7 * 4)$$

Figure 2-4. Bit-Band Mapping

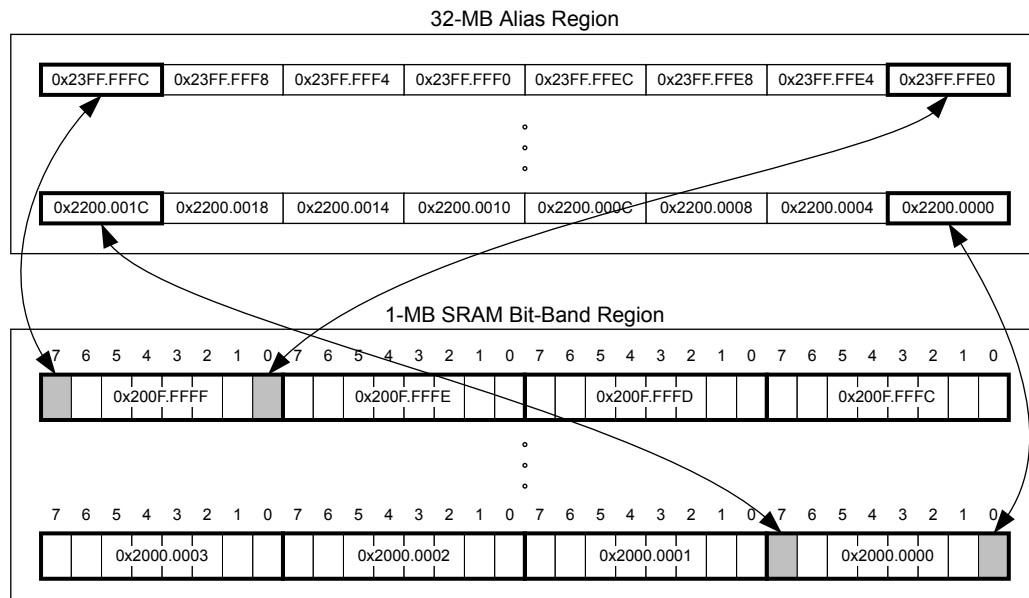

2.4.5.1 Directly Accessing an Alias Region

Writing to a word in the alias region updates a single bit in the bit-band region.

Bit 0 of the value written to a word in the alias region determines the value written to the targeted bit in the bit-band region. Writing a value with bit 0 set writes a 1 to the bit-band bit, and writing a value with bit 0 clear writes a 0 to the bit-band bit.

Bits 31:1 of the alias word have no effect on the bit-band bit. Writing 0x01 has the same effect as writing 0xFF. Writing 0x00 has the same effect as writing 0x0E.

When reading a word in the alias region, 0x0000.0000 indicates that the targeted bit in the bit-band region is clear and 0x0000.0001 indicates that the targeted bit in the bit-band region is set.

2.4.5.2 Directly Accessing a Bit-Band Region

“Behavior of Memory Accesses” on page 113 describes the behavior of direct byte, halfword, or word accesses to the bit-band regions.

2.4.6 Data Storage

The processor views memory as a linear collection of bytes numbered in ascending order from zero. For example, bytes 0-3 hold the first stored word, and bytes 4-7 hold the second stored word. Data is stored in little-endian format, with the least-significant byte (lsbyte) of a word stored at the lowest-numbered byte, and the most-significant byte (msbyte) stored at the highest-numbered byte. Figure 2-5 on page 118 illustrates how data is stored.

Figure 2-5. Data Storage

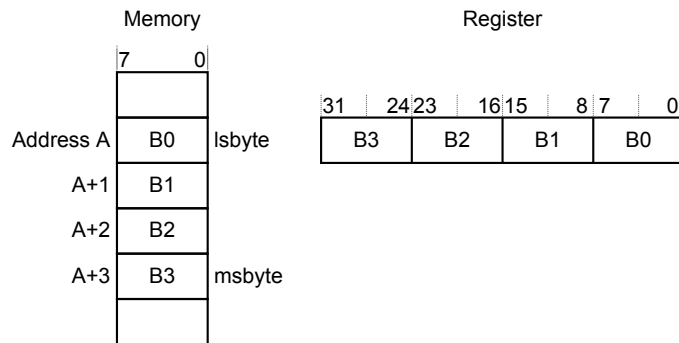

2.4.7 Synchronization Primitives

The Cortex-M4F instruction set includes pairs of synchronization primitives which provide a non-blocking mechanism that a thread or process can use to obtain exclusive access to a memory location. Software can use these primitives to perform a guaranteed read-modify-write memory update sequence or for a semaphore mechanism.

Note: The available pairs of synchronization primitives are only available for single processor use and should not be used with multi-processor systems.

A pair of synchronization primitives consists of:

- A Load-Exclusive instruction, which is used to read the value of a memory location and requests exclusive access to that location.
- A Store-Exclusive instruction, which is used to attempt to write to the same memory location and returns a status bit to a register. If this status bit is clear, it indicates that the thread or process gained exclusive access to the memory and the write succeeds; if this status bit is set, it indicates that the thread or process did not gain exclusive access to the memory and no write was performed.

The pairs of Load-Exclusive and Store-Exclusive instructions are:

- The word instructions `LDREX` and `STREX`
- The halfword instructions `LDREXH` and `STREXH`
- The byte instructions `LDREXB` and `STREXB`

Software must use a Load-Exclusive instruction with the corresponding Store-Exclusive instruction.

To perform an exclusive read-modify-write of a memory location, software must:

1. Use a Load-Exclusive instruction to read the value of the location.
2. Modify the value, as required.
3. Use a Store-Exclusive instruction to attempt to write the new value back to the memory location.
4. Test the returned status bit.

If the status bit is clear, the read-modify-write completed successfully. If the status bit is set, no write was performed, which indicates that the value returned at step 1 might be out of date. The software must retry the entire read-modify-write sequence.

Software can use the synchronization primitives to implement a semaphore as follows:

1. Use a Load-Exclusive instruction to read from the semaphore address to check whether the semaphore is free.
2. If the semaphore is free, use a Store-Exclusive to write the claim value to the semaphore address.
3. If the returned status bit from step 2 indicates that the Store-Exclusive succeeded, then the software has claimed the semaphore. However, if the Store-Exclusive failed, another process might have claimed the semaphore after the software performed step 1.

The Cortex-M4F includes an exclusive access monitor that tags the fact that the processor has executed a Load-Exclusive instruction. The processor removes its exclusive access tag if:

- It executes a `CLREX` instruction.
- It executes a Store-Exclusive instruction, regardless of whether the write succeeds.
- An exception occurs, which means the processor can resolve semaphore conflicts between different threads.

For more information about the synchronization primitive instructions, see the Cortex™-M4 instruction set chapter in the *ARM® Cortex™-M4 Devices Generic User Guide* (literature number [ARM DUI 0553A](#)).

2.5 Exception Model

The ARM Cortex-M4F processor and the Nested Vectored Interrupt Controller (NVIC) prioritize and handle all exceptions in Handler Mode. The processor state is automatically stored to the stack on an exception and automatically restored from the stack at the end of the Interrupt Service Routine (ISR). The vector is fetched in parallel to the state saving, enabling efficient interrupt entry. The processor supports tail-chaining, which enables back-to-back interrupts to be performed without the overhead of state saving and restoration.

Table 2-8 on page 121 lists all exception types. Software can set eight priority levels on seven of these exceptions (system handlers) as well as on 106 interrupts (listed in Table 2-9 on page 122).

Priorities on the system handlers are set with the NVIC **System Handler Priority n (SYSPRIn)** registers. Interrupts are enabled through the NVIC **Interrupt Set Enable n (ENn)** register and prioritized with the NVIC **Interrupt Priority n (PRIn)** registers. Priorities can be grouped by splitting priority levels into preemption priorities and subpriorities. All the interrupt registers are described in “Nested Vectored Interrupt Controller (NVIC)” on page 143.

Internally, the highest user-programmable priority (0) is treated as fourth priority, after a Reset, Non-Maskable Interrupt (NMI), and a Hard Fault, in that order. Note that 0 is the default priority for all the programmable priorities.

Important: After a write to clear an interrupt source, it may take several processor cycles for the NVIC to see the interrupt source deassert. Thus if the interrupt clear is done as the last action in an interrupt handler, it is possible for the interrupt handler to complete while

the NVIC sees the interrupt as still asserted, causing the interrupt handler to be re-entered errantly. This situation can be avoided by either clearing the interrupt source at the beginning of the interrupt handler or by performing a read or write after the write to clear the interrupt source (and flush the write buffer).

See “Nested Vectored Interrupt Controller (NVIC)” on page 143 for more information on exceptions and interrupts.

2.5.1 Exception States

Each exception is in one of the following states:

- **Inactive.** The exception is not active and not pending.
- **Pending.** The exception is waiting to be serviced by the processor. An interrupt request from a peripheral or from software can change the state of the corresponding interrupt to pending.
- **Active.** An exception that is being serviced by the processor but has not completed.
Note: An exception handler can interrupt the execution of another exception handler. In this case, both exceptions are in the active state.
- **Active and Pending.** The exception is being serviced by the processor, and there is a pending exception from the same source.

2.5.2 Exception Types

The exception types are:

- **Reset.** Reset is invoked on power up or a warm reset. The exception model treats reset as a special form of exception. When reset is asserted, the operation of the processor stops, potentially at any point in an instruction. When reset is deasserted, execution restarts from the address provided by the reset entry in the vector table. Execution restarts as privileged execution in Thread mode.
- **NMI.** A non-maskable Interrupt (NMI) can be signaled using the NMI signal or triggered by software using the **Interrupt Control and State (INTCTRL)** register. This exception has the highest priority other than reset. NMI is permanently enabled and has a fixed priority of -2. NMIs cannot be masked or prevented from activation by any other exception or preempted by any exception other than reset.
- **Hard Fault.** A hard fault is an exception that occurs because of an error during exception processing, or because an exception cannot be managed by any other exception mechanism. Hard faults have a fixed priority of -1, meaning they have higher priority than any exception with configurable priority.
- **Memory Management Fault.** A memory management fault is an exception that occurs because of a memory protection related fault, including access violation and no match. The MPU or the fixed memory protection constraints determine this fault, for both instruction and data memory transactions. This fault is used to abort instruction accesses to Execute Never (XN) memory regions, even if the MPU is disabled.
- **Bus Fault.** A bus fault is an exception that occurs because of a memory-related fault for an instruction or data memory transaction such as a prefetch fault or a memory access fault. This fault can be enabled or disabled.

- **Usage Fault.** A usage fault is an exception that occurs because of a fault related to instruction execution, such as:
 - An undefined instruction
 - An illegal unaligned access
 - Invalid state on instruction execution
 - An error on exception return
 An unaligned address on a word or halfword memory access or division by zero can cause a usage fault when the core is properly configured.
- **SVCcall.** A supervisor call (SVC) is an exception that is triggered by the SVC instruction. In an OS environment, applications can use SVC instructions to access OS kernel functions and device drivers.
- **Debug Monitor.** This exception is caused by the debug monitor (when not halting). This exception is only active when enabled. This exception does not activate if it is a lower priority than the current activation.
- **PendSV.** PendSV is a pendable, interrupt-driven request for system-level service. In an OS environment, use PendSV for context switching when no other exception is active. PendSV is triggered using the **Interrupt Control and State (INTCTRL)** register.
- **SysTick.** A SysTick exception is an exception that the system timer generates when it reaches zero when it is enabled to generate an interrupt. Software can also generate a SysTick exception using the **Interrupt Control and State (INTCTRL)** register. In an OS environment, the processor can use this exception as system tick.
- **Interrupt (IRQ).** An interrupt, or IRQ, is an exception signaled by a peripheral or generated by a software request and fed through the NVIC (prioritized). All interrupts are asynchronous to instruction execution. In the system, peripherals use interrupts to communicate with the processor. Table 2-9 on page 122 lists the interrupts on the TM4C129ENCPDT controller.

For an asynchronous exception, other than reset, the processor can execute another instruction between when the exception is triggered and when the processor enters the exception handler.

Privileged software can disable the exceptions that Table 2-8 on page 121 shows as having configurable priority (see the **SYSHNDCTRL** register on page 187 and the **DIS0** register on page 162).

For more information about hard faults, memory management faults, bus faults, and usage faults, see “Fault Handling” on page 130.

Table 2-8. Exception Types

Exception Type	Vector Number	Priority ^a	Vector Address or Offset ^b	Activation
-	0	-	0x0000.0000	Stack top is loaded from the first entry of the vector table on reset.
Reset	1	-3 (highest)	0x0000.0004	Asynchronous
Non-Maskable Interrupt (NMI)	2	-2	0x0000.0008	Asynchronous
Hard Fault	3	-1	0x0000.000C	-
Memory Management	4	programmable ^c	0x0000.0010	Synchronous

Table 2-8. Exception Types (continued)

Exception Type	Vector Number	Priority ^a	Vector Address or Offset ^b	Activation
Bus Fault	5	programmable ^c	0x0000.0014	Synchronous when precise and asynchronous when imprecise
Usage Fault	6	programmable ^c	0x0000.0018	Synchronous
-	7-10	-	-	Reserved
SVCall	11	programmable ^c	0x0000.002C	Synchronous
Debug Monitor	12	programmable ^c	0x0000.0030	Synchronous
-	13	-	-	Reserved
PendSV	14	programmable ^c	0x0000.0038	Asynchronous
SysTick	15	programmable ^c	0x0000.003C	Asynchronous
Interrupts	16 and above	programmable ^d	0x0000.0040 and above	Asynchronous

a. 0 is the default priority for all the programmable priorities.

b. See "Vector Table" on page 125.

c. See **SYSPR11** on page 184.

d. See **PRIn** registers on page 166.

Table 2-9. Interrupts

Vector Number	Interrupt Number (Bit in Interrupt Registers)	Vector Address or Offset	Description
0-15	-	0x0000.0000 - 0x0000.003C	Processor exceptions
16	0	0x0000.0040	GPIO Port A
17	1	0x0000.0044	GPIO Port B
18	2	0x0000.0048	GPIO Port C
19	3	0x0000.004C	GPIO Port D
20	4	0x0000.0050	GPIO Port E
21	5	0x0000.0054	UART0
22	6	0x0000.0058	UART1
23	7	0x0000.005C	SSI0
24	8	0x0000.0060	I ² C0
25	9	0x0000.0064	PWM Fault
26	10	0x0000.0068	PWM Generator 0
27	11	0x0000.006C	PWM Generator 1
28	12	0x0000.0070	PWM Generator 2
29	13	0x0000.0074	QEIO
30	14	0x0000.0078	ADC0 Sequence 0
31	15	0x0000.007C	ADC0 Sequence 1
32	16	0x0000.0080	ADC0 Sequence 2
33	17	0x0000.0084	ADC0 Sequence 3
34	18	0x0000.0088	Watchdog Timers 0 and 1
35	19	0x0000.008C	16/32-Bit Timer 0A
36	20	0x0000.0090	16/32-Bit Timer 0B
37	21	0x0000.0094	16/32-Bit Timer 1A

Table 2-9. Interrupts (continued)

Vector Number	Interrupt Number (Bit in Interrupt Registers)	Vector Address or Offset	Description
38	22	0x0000.0098	16/32-Bit Timer 1B
39	23	0x0000.009C	16/32-Bit Timer 2A
40	24	0x0000.00A0	16/32-Bit Timer 2B
41	25	0x0000.00A4	Analog Comparator 0
42	26	0x0000.00A8	Analog Comparator 1
43	27	0x0000.00AC	Analog Comparator 2
44	28	0x0000.00B0	System Control
45	29	0x0000.00B4	Flash Memory Control
46	30	0x0000.00B8	GPIO Port F
47	31	0x0000.00BC	GPIO Port G
48	32	0x0000.00C0	GPIO Port H
49	33	0x0000.00C4	UART2
50	34	0x0000.00C8	SSI1
51	35	0x0000.00CC	16/32-Bit Timer 3A
52	36	0x0000.00D0	16/32-Bit Timer 3B
53	37	0x0000.00D4	I ² C1
54	38	0x0000.00D8	CAN 0
55	39	0x0000.00DC	CAN1
56	40	0x0000.00E0	Ethernet MAC
57	41	0x0000.00E4	HIB
58	42	0x0000.00E8	USB MAC
59	43	0x0000.00EC	PWM Generator 3
60	44	0x0000.00F0	uDMA 0 Software
61	45	0x0000.00F4	uDMA 0 Error
62	46	0x0000.00F8	ADC1 Sequence 0
63	47	0x0000.00FC	ADC1 Sequence 1
64	48	0x0000.0100	ADC1 Sequence 2
65	49	0x0000.0104	ADC1 Sequence 3
66	50	0x0000.0108	EPI 0
67	51	0x0000.010C	GPIO Port J
68	52	0x0000.0110	GPIO Port K
69	53	0x0000.0114	GPIO Port L
70	54	0x0000.0118	SSI 2
71	55	0x0000.011C	SSI 3
72	56	0x0000.0120	UART 3
73	57	0x0000.0124	UART 4
74	58	0x0000.0128	UART 5
75	59	0x0000.012C	UART 6
76	60	0x0000.0130	UART 7
77	61	0x0000.0134	I ² C 2
78	62	0x0000.0138	I ² C 3

Table 2-9. Interrupts (continued)

Vector Number	Interrupt Number (Bit in Interrupt Registers)	Vector Address or Offset	Description
79	63	0x0000.013C	Timer 4A
80	64	0x0000.0140	Timer 4B
81	65	0x0000.0144	Timer 5A
82	66	0x0000.0148	Timer 5B
83	67	0x0000.014C	Floating-Point Exception (imprecise)
84-85	68-69	-	Reserved
86	70	0x0000.0158	I ² C 4
87	71	0x0000.015C	I ² C 5
88	72	0x0000.0160	GPIO Port M
89	73	0x0000.0164	GPIO Port N
90	74	-	Reserved
91	75	0x0000.016C	Tamper
92	76	0x0000.017	GPIO Port P (Summary or P0)
93	77	0x0000.0174	GPIO Port P1
94	78	0x0000.0178	GPIO Port P2
95	79	0x0000.017C	GPIO Port P3
96	80	0x0000.0180	GPIO Port P4
97	81	0x0000.0184	GPIO Port P5
98	82	0x0000.0188	GPIO Port P6
99	83	0x0000.018C	GPIO Port P7
100	84	0x0000.0190	GPIO Port Q (Summary or Q0)
101	85	0x0000.0194	GPIO Port Q1
102	86	0x0000.0198	GPIO Port Q2
103	87	0x0000.019C	GPIO Port Q3
104	88	0x0000.01A0	GPIO Port Q4
105	89	0x0000.01A4	GPIO Port Q5
106	90	0x0000.01A8	GPIO Port Q6
107	91	0x0000.01AC	GPIO Port Q7
108-109	92-93	-	Reserved
110	94	0x0000.01B8	SHA/MD5
111	95	0x0000.01BC	AES
112	96	0x0000.01C0	DES
113	97	-	Reserved
114	98	0x0000.01C8	16/32-Bit Timer 6A
115	99	0x0000.01CC	16/32-Bit Timer 6B
116	100	0x0000.01D0	16/32-Bit Timer 7A
117	101	0x0000.01D4	16/32-Bit Timer 7B
118	102	0x0000.01D8	I ² C 6
119	103	0x0000.01DC	I ² C 7
120-124	104-108	-	Reserved
125	109	0x0000.01F4	I ² C 8

Table 2-9. Interrupts (*continued*)

Vector Number	Interrupt Number (Bit in Interrupt Registers)	Vector Address or Offset	Description
126	110	0x0000.01F8	I ² C 9
127-129	111-113	-	Reserved

2.5.3 Exception Handlers

The processor handles exceptions using:

- **Interrupt Service Routines (ISRs).** Interrupts (IRQx) are the exceptions handled by ISRs.
- **Fault Handlers.** Hard fault, memory management fault, usage fault, and bus fault are fault exceptions handled by the fault handlers.
- **System Handlers.** NMI, PendSV, SVCall, SysTick, and the fault exceptions are all system exceptions that are handled by system handlers.

2.5.4 Vector Table

The vector table contains the reset value of the stack pointer and the start addresses, also called exception vectors, for all exception handlers. The vector table is constructed using the vector address or offset shown in Table 2-8 on page 121. Figure 2-6 on page 126 shows the order of the exception vectors in the vector table. The least-significant bit of each vector must be 1, indicating that the exception handler is Thumb code

Figure 2-6. Vector Table

Exception number	IRQ number	Offset	Vector
(N+16)	(N)	0x040 + 0x(N*4)	IRQ N
.	.	.	.
.	.	.	.
.	.	0x004C	.
18	2	0x0048	IRQ2
17	1	0x0044	IRQ1
16	0	0x0040	IRQ0
15	-1	0x003C	Systick
14	-2	0x0038	PendSV
13			Reserved
12			Reserved for Debug
11	-5	0x002C	SVCcall
10			Reserved
9			
8			
7			
6	-10	0x0018	Usage fault
5	-11	0x0014	Bus fault
4	-12	0x0010	Memory management fault
3	-13	0x000C	Hard fault
2	-14	0x0008	NMI
1		0x0004	Reset
0		0x0000	Initial SP value

On system reset, the vector table is fixed at address 0x0000.0000. Privileged software can write to the **Vector Table Offset (VTABLE)** register to relocate the vector table start address to a different memory location, in the range 0x0000.0400 to 0x3FFF.FC00 (see “Vector Table” on page 125). Note that when configuring the **VTABLE** register, the offset must be aligned on a 1024-byte boundary.

2.5.5 Exception Priorities

As Table 2-8 on page 121 shows, all exceptions have an associated priority, with a lower priority value indicating a higher priority and configurable priorities for all exceptions except Reset, Hard fault, and NMI. If software does not configure any priorities, then all exceptions with a configurable priority have a priority of 0. For information about configuring exception priorities, see page 184 and page 166.

Note: Configurable priority values for the Tiva™ C Series implementation are in the range 0-7. This means that the Reset, Hard fault, and NMI exceptions, with fixed negative priority values, always have higher priority than any other exception.

For example, assigning a higher priority value to IRQ[0] and a lower priority value to IRQ[1] means that IRQ[1] has higher priority than IRQ[0]. If both IRQ[1] and IRQ[0] are asserted, IRQ[1] is processed before IRQ[0].

If multiple pending exceptions have the same priority, the pending exception with the lowest exception number takes precedence. For example, if both IRQ[0] and IRQ[1] are pending and have the same priority, then IRQ[0] is processed before IRQ[1].

When the processor is executing an exception handler, the exception handler is preempted if a higher priority exception occurs. If an exception occurs with the same priority as the exception being handled, the handler is not preempted, irrespective of the exception number. However, the status of the new interrupt changes to pending.

2.5.6 Interrupt Priority Grouping

To increase priority control in systems with interrupts, the NVIC supports priority grouping. This grouping divides each interrupt priority register entry into two fields:

- An upper field that defines the group priority
- A lower field that defines a subpriority within the group

Only the group priority determines preemption of interrupt exceptions. When the processor is executing an interrupt exception handler, another interrupt with the same group priority as the interrupt being handled does not preempt the handler.

If multiple pending interrupts have the same group priority, the subpriority field determines the order in which they are processed. If multiple pending interrupts have the same group priority and subpriority, the interrupt with the lowest IRQ number is processed first.

For information about splitting the interrupt priority fields into group priority and subpriority, see page 178.

2.5.7 Exception Entry and Return

Descriptions of exception handling use the following terms:

- **Preemption.** When the processor is executing an exception handler, an exception can preempt the exception handler if its priority is higher than the priority of the exception being handled. See “Interrupt Priority Grouping” on page 127 for more information about preemption by an interrupt. When one exception preempts another, the exceptions are called nested exceptions. See “Exception Entry” on page 128 for more information.
- **Return.** Return occurs when the exception handler is completed, and there is no pending exception with sufficient priority to be serviced and the completed exception handler was not handling a late-arriving exception. The processor pops the stack and restores the processor state to the state it had before the interrupt occurred. See “Exception Return” on page 129 for more information.
- **Tail-Chaining.** This mechanism speeds up exception servicing. On completion of an exception handler, if there is a pending exception that meets the requirements for exception entry, the stack pop is skipped and control transfers to the new exception handler.
- **Late-Arriving.** This mechanism speeds up preemption. If a higher priority exception occurs during state saving for a previous exception, the processor switches to handle the higher priority exception and initiates the vector fetch for that exception. State saving is not affected by late arrival because the state saved is the same for both exceptions. Therefore, the state saving continues uninterrupted. The processor can accept a late arriving exception until the first instruction of the exception handler of the original exception enters the execute stage of the processor. On

return from the exception handler of the late-arriving exception, the normal tail-chaining rules apply.

2.5.7.1 Exception Entry

Exception entry occurs when there is a pending exception with sufficient priority and either the processor is in Thread mode or the new exception is of higher priority than the exception being handled, in which case the new exception preempts the original exception.

When one exception preempts another, the exceptions are nested.

Sufficient priority means the exception has more priority than any limits set by the mask registers (see **PRIMASK** on page 102, **FAULTMASK** on page 103, and **BASEPRI** on page 104). An exception with less priority than this is pending but is not handled by the processor.

When the processor takes an exception, unless the exception is a tail-chained or a late-arriving exception, the processor pushes information onto the current stack. This operation is referred to as *stacking* and the structure of eight data words is referred to as *stack frame*.

When using floating-point routines, the Cortex-M4F processor automatically stacks the architected floating-point state on exception entry. Figure 2-7 on page 129 shows the Cortex-M4F stack frame layout when floating-point state is preserved on the stack as the result of an interrupt or an exception.

Note: Where stack space for floating-point state is not allocated, the stack frame is the same as that of ARMv7-M implementations without an FPU. Figure 2-7 on page 129 shows this stack frame also.

Figure 2-7. Exception Stack Frame

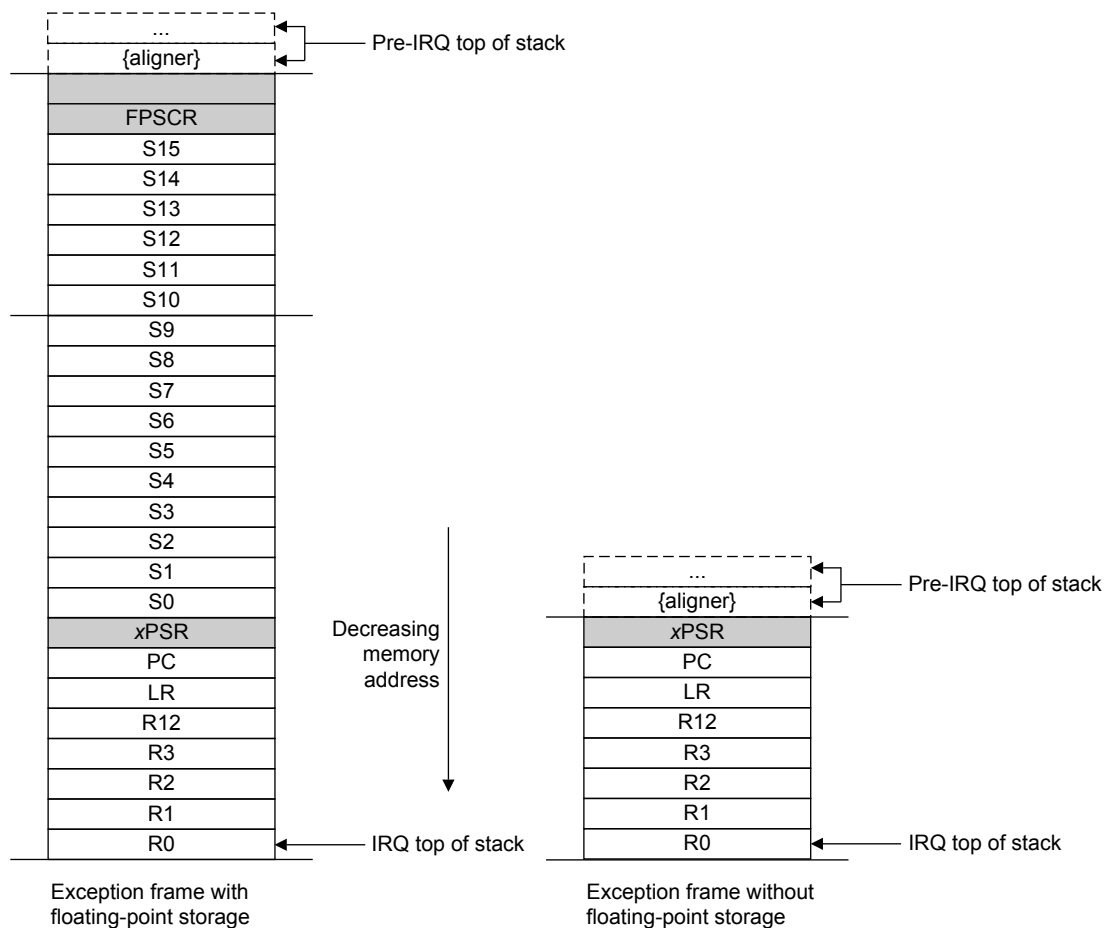

Immediately after stacking, the stack pointer indicates the lowest address in the stack frame.

The stack frame includes the return address, which is the address of the next instruction in the interrupted program. This value is restored to the **PC** at exception return so that the interrupted program resumes.

In parallel with the stacking operation, the processor performs a vector fetch that reads the exception handler start address from the vector table. When stacking is complete, the processor starts executing the exception handler. At the same time, the processor writes an **EXC_RETURN** value to the **LR**, indicating which stack pointer corresponds to the stack frame and what operation mode the processor was in before the entry occurred.

If no higher-priority exception occurs during exception entry, the processor starts executing the exception handler and automatically changes the status of the corresponding pending interrupt to active.

If another higher-priority exception occurs during exception entry, known as late arrival, the processor starts executing the exception handler for this exception and does not change the pending status of the earlier exception.

2.5.7.2 Exception Return

Exception return occurs when the processor is in Handler mode and executes one of the following instructions to load the **EXC_RETURN** value into the **PC**:

- An LDM or POP instruction that loads the PC
- A BX instruction using any register
- An LDR instruction with the PC as the destination

EXC_RETURN is the value loaded into the LR on exception entry. The exception mechanism relies on this value to detect when the processor has completed an exception handler. The lowest five bits of this value provide information on the return stack and processor mode. Table 2-10 on page 130 shows the EXC_RETURN values with a description of the exception return behavior.

EXC_RETURN bits 31:5 are all set. When this value is loaded into the PC, it indicates to the processor that the exception is complete, and the processor initiates the appropriate exception return sequence.

Table 2-10. Exception Return Behavior

EXC_RETURN[31:0]	Description
0xFFFF.FFE0	Reserved
0xFFFF.FFE1	Return to Handler mode. Exception return uses floating-point state from MSP . Execution uses MSP after return.
0xFFFF.FFE2 - 0xFFFF.FFE8	Reserved
0xFFFF.FFE9	Return to Thread mode. Exception return uses floating-point state from MSP . Execution uses MSP after return.
0xFFFF.FFEA - 0xFFFF.FFEC	Reserved
0xFFFF.FFED	Return to Thread mode. Exception return uses floating-point state from PSP . Execution uses PSP after return.
0xFFFF.FFEE - 0xFFFF.FFF0	Reserved
0xFFFF.FFF1	Return to Handler mode. Exception return uses non-floating-point state from MSP . Execution uses MSP after return.
0xFFFF.FFF2 - 0xFFFF.FFF8	Reserved
0xFFFF.FFF9	Return to Thread mode. Exception return uses non-floating-point state from MSP . Execution uses MSP after return.
0xFFFF.FFFA - 0xFFFF.FFFC	Reserved
0xFFFF.FFFD	Return to Thread mode. Exception return uses non-floating-point state from PSP . Execution uses PSP after return.
0xFFFF.FFFE - 0xFFFF.FFFF	Reserved

2.6 Fault Handling

Faults are a subset of the exceptions (see “Exception Model” on page 119). The following conditions generate a fault:

- A bus error on an instruction fetch or vector table load or a data access.

- An internally detected error such as an undefined instruction or an attempt to change state with a BX instruction.
- Attempting to execute an instruction from a memory region marked as Non-Executable (XN).
- An MPU fault because of a privilege violation or an attempt to access an unmanaged region.

2.6.1 Fault Types

Table 2-11 on page 131 shows the types of fault, the handler used for the fault, the corresponding fault status register, and the register bit that indicates the fault has occurred. See page 191 for more information about the fault status registers.

Table 2-11. Faults

Fault	Handler	Fault Status Register	Bit Name
Bus error on a vector read	Hard fault	Hard Fault Status (HFAULTSTAT)	VECT
Fault escalated to a hard fault	Hard fault	Hard Fault Status (HFAULTSTAT)	FORCED
MPU or default memory mismatch on instruction access	Memory management fault	Memory Management Fault Status (MFAULTSTAT)	IERR ^a
MPU or default memory mismatch on data access	Memory management fault	Memory Management Fault Status (MFAULTSTAT)	DERR
MPU or default memory mismatch on exception stacking	Memory management fault	Memory Management Fault Status (MFAULTSTAT)	MSTKE
MPU or default memory mismatch on exception unstacking	Memory management fault	Memory Management Fault Status (MFAULTSTAT)	MUSTKE
MPU or default memory mismatch during lazy floating-point state preservation	Memory management fault	Memory Management Fault Status (MFAULTSTAT)	MLSPERR
Bus error during exception stacking	Bus fault	Bus Fault Status (BFAULTSTAT)	BSTKE
Bus error during exception unstacking	Bus fault	Bus Fault Status (BFAULTSTAT)	BUSTKE
Bus error during instruction prefetch	Bus fault	Bus Fault Status (BFAULTSTAT)	IBUS
Bus error during lazy floating-point state preservation	Bus fault	Bus Fault Status (BFAULTSTAT)	BLSPE
Precise data bus error	Bus fault	Bus Fault Status (BFAULTSTAT)	PRECISE
Imprecise data bus error	Bus fault	Bus Fault Status (BFAULTSTAT)	IMPRE
Attempt to access a coprocessor	Usage fault	Usage Fault Status (UFAULTSTAT)	NOCP
Undefined instruction	Usage fault	Usage Fault Status (UFAULTSTAT)	UNDEF
Attempt to enter an invalid instruction set state ^b	Usage fault	Usage Fault Status (UFAULTSTAT)	INVSTAT
Invalid EXC_RETURN value	Usage fault	Usage Fault Status (UFAULTSTAT)	INVPC
Illegal unaligned load or store	Usage fault	Usage Fault Status (UFAULTSTAT)	UNALIGN
Divide by 0	Usage fault	Usage Fault Status (UFAULTSTAT)	DIV0

a. Occurs on an access to an XN region even if the MPU is disabled.

b. Attempting to use an instruction set other than the Thumb instruction set, or returning to a non load-store-multiply instruction with ICI continuation.

2.6.2 Fault Escalation and Hard Faults

All fault exceptions except for hard fault have configurable exception priority (see **SYSPRI1** on page 184). Software can disable execution of the handlers for these faults (see **SYSHNDCTRL** on page 187).

Usually, the exception priority, together with the values of the exception mask registers, determines whether the processor enters the fault handler, and whether a fault handler can preempt another fault handler as described in “Exception Model” on page 119.

In some situations, a fault with configurable priority is treated as a hard fault. This process is called priority escalation, and the fault is described as *escalated to hard fault*. Escalation to hard fault occurs when:

- A fault handler causes the same kind of fault as the one it is servicing. This escalation to hard fault occurs because a fault handler cannot preempt itself because it must have the same priority as the current priority level.
- A fault handler causes a fault with the same or lower priority as the fault it is servicing. This situation happens because the handler for the new fault cannot preempt the currently executing fault handler.
- An exception handler causes a fault for which the priority is the same as or lower than the currently executing exception.
- A fault occurs and the handler for that fault is not enabled.

If a bus fault occurs during a stack push when entering a bus fault handler, the bus fault does not escalate to a hard fault. Thus if a corrupted stack causes a fault, the fault handler executes even though the stack push for the handler failed. The fault handler operates but the stack contents are corrupted.

Note: Only Reset and NMI can preempt the fixed priority hard fault. A hard fault can preempt any exception other than Reset, NMI, or another hard fault.

2.6.3 Fault Status Registers and Fault Address Registers

The fault status registers indicate the cause of a fault. For bus faults and memory management faults, the fault address register indicates the address accessed by the operation that caused the fault, as shown in Table 2-12 on page 132.

Table 2-12. Fault Status and Fault Address Registers

Handler	Status Register Name	Address Register Name	Register Description
Hard fault	Hard Fault Status (HFAULTSTAT)	-	page 197
Memory management fault	Memory Management Fault Status (MFAULTSTAT)	Memory Management Fault Address (MMADDR)	page 191 page 198
Bus fault	Bus Fault Status (BFAULTSTAT)	Bus Fault Address (FAULTADDR)	page 191 page 199
Usage fault	Usage Fault Status (UFAULTSTAT)	-	page 191

2.6.4 Lockup

The processor enters a lockup state if a hard fault occurs when executing the NMI or hard fault handlers. When the processor is in the lockup state, it does not execute any instructions. The processor remains in lockup state until it is reset, an NMI occurs, or it is halted by a debugger.

Note: If the lockup state occurs from the NMI handler, a subsequent NMI does not cause the processor to leave the lockup state.

2.7 Power Management

The Cortex-M4F processor sleep modes reduce power consumption:

- Sleep mode stops the processor clock.
- Deep-sleep mode stops the system clock and switches off the PLL and Flash memory.

The `SLEEPDEEP` bit of the **System Control (SYSCTRL)** register selects which sleep mode is used (see page 180). For more information about the behavior of the sleep modes, see “System Control” on page 246.

This section describes the mechanisms for entering sleep mode and the conditions for waking up from sleep mode, both of which apply to Sleep mode and Deep-sleep mode.

2.7.1 Entering Sleep Modes

This section describes the mechanisms software can use to put the processor into one of the sleep modes.

The system can generate spurious wake-up events, for example a debug operation wakes up the processor. Therefore, software must be able to put the processor back into sleep mode after such an event. A program might have an idle loop to put the processor back to sleep mode.

2.7.1.1 Wait for Interrupt

The wait for interrupt instruction, `WFI`, causes immediate entry to sleep mode unless the wake-up condition is true (see “Wake Up from WFI or Sleep-on-Exit” on page 134). When the processor executes a `WFI` instruction, it stops executing instructions and enters sleep mode. See the Cortex™-M4 instruction set chapter in the *ARM® Cortex™-M4 Devices Generic User Guide (literature number [ARM DUI 0553A](#))* for more information.

2.7.1.2 Wait for Event

The wait for event instruction, `WFE`, causes entry to sleep mode conditional on the value of a one-bit event register. When the processor executes a `WFE` instruction, it checks the event register. If the register is 0, the processor stops executing instructions and enters sleep mode. If the register is 1, the processor clears the register and continues executing instructions without entering sleep mode.

If the event register is 1, the processor must not enter sleep mode on execution of a `WFE` instruction. Typically, this situation occurs if an `SEV` instruction has been executed. Software cannot access this register directly.

See the Cortex™-M4 instruction set chapter in the *ARM® Cortex™-M4 Devices Generic User Guide (literature number [ARM DUI 0553A](#))* for more information.

2.7.1.3 Sleep-on-Exit

If the `SLEEPEXIT` bit of the **SYSCTRL** register is set, when the processor completes the execution of all exception handlers, it returns to Thread mode and immediately enters sleep mode. This mechanism can be used in applications that only require the processor to run when an exception occurs.

2.7.2 Wake Up from Sleep Mode

The conditions for the processor to wake up depend on the mechanism that caused it to enter sleep mode.

2.7.2.1 Wake Up from WFI or Sleep-on-Exit

Normally, the processor wakes up only when the NVIC detects an exception with sufficient priority to cause exception entry. Some embedded systems might have to execute system restore tasks after the processor wakes up and before executing an interrupt handler. Entry to the interrupt handler can be delayed by setting the `PRIMASK` bit and clearing the `FAULTMASK` bit. If an interrupt arrives that is enabled and has a higher priority than current exception priority, the processor wakes up but does not execute the interrupt handler until the processor clears `PRIMASK`. For more information about **PRIMASK** and **FAULTMASK**, see page 102 and page 103.

2.7.2.2 Wake Up from WFE

The processor wakes up if it detects an exception with sufficient priority to cause exception entry.

In addition, if the `SEVONPEND` bit in the **SYSCTRL** register is set, any new pending interrupt triggers an event and wakes up the processor, even if the interrupt is disabled or has insufficient priority to cause exception entry. For more information about **SYSCTRL**, see page 180.

2.8 Instruction Set Summary

The processor implements a version of the Thumb instruction set. Table 2-13 on page 134 lists the supported instructions.

Note: In Table 2-13 on page 134:

- Angle brackets, `<>`, enclose alternative forms of the operand
- Braces, `{}`, enclose optional operands
- The Operands column is not exhaustive
- `Op2` is a flexible second operand that can be either a register or a constant
- Most instructions can use an optional condition code suffix

For more information on the instructions and operands, see the instruction descriptions in the *ARM® Cortex™-M4 Technical Reference Manual*.

Table 2-13. Cortex-M4F Instruction Summary

Mnemonic	Operands	Brief Description	Flags
ADC, ADCS	{Rd,} Rn, Op2	Add with carry	N, Z, C, V
ADD, ADDS	{Rd,} Rn, Op2	Add	N, Z, C, V
ADD, ADDW	{Rd,} Rn, #imm12	Add	-
ADR	Rd, label	Load PC-relative address	-
AND, ANDS	{Rd,} Rn, Op2	Logical AND	N, Z, C
ASR, ASRS	Rd, Rm, <Rs #n>	Arithmetic shift right	N, Z, C
B	label	Branch	-
BFC	Rd, #lsb, #width	Bit field clear	-
BFI	Rd, Rn, #lsb, #width	Bit field insert	-
BIC, BICS	{Rd,} Rn, Op2	Bit clear	N, Z, C
BKPT	#imm	Breakpoint	-
BL	label	Branch with link	-
BLX	Rm	Branch indirect with link	-
BX	Rm	Branch indirect	-
CBNZ	Rn, label	Compare and branch if non-zero	-

Table 2-13. Cortex-M4F Instruction Summary (continued)

Mnemonic	Operands	Brief Description	Flags
CBZ	Rn, label	Compare and branch if zero	-
CLREX	-	Clear exclusive	-
CLZ	Rd, Rm	Count leading zeros	-
CMN	Rn, Op2	Compare negative	N, Z, C, V
CMP	Rn, Op2	Compare	N, Z, C, V
CPSID	i	Change processor state, disable interrupts	-
CPSIE	i	Change processor state, enable interrupts	-
DMB	-	Data memory barrier	-
DSB	-	Data synchronization barrier	-
EOR, EORS	{Rd,} Rn, Op2	Exclusive OR	N, Z, C
ISB	-	Instruction synchronization barrier	-
IT	-	If-Then condition block	-
LDM	Rn{!}, reglist	Load multiple registers, increment after	-
LDMDB, LDMEA	Rn{!}, reglist	Load multiple registers, decrement before	-
LDMFD, LDMIA	Rn{!}, reglist	Load multiple registers, increment after	-
LDR	Rt, [Rn, #offset]	Load register with word	-
LDRB, LDRBT	Rt, [Rn, #offset]	Load register with byte	-
LDRD	Rt, Rt2, [Rn, #offset]	Load register with two bytes	-
LDREX	Rt, [Rn, #offset]	Load register exclusive	-
LDREXB	Rt, [Rn]	Load register exclusive with byte	-
LDREXH	Rt, [Rn]	Load register exclusive with halfword	-
LDRH, LDRHT	Rt, [Rn, #offset]	Load register with halfword	-
LDRSB, LDRSBT	Rt, [Rn, #offset]	Load register with signed byte	-
LDRSH, LDRSHT	Rt, [Rn, #offset]	Load register with signed halfword	-
LDRT	Rt, [Rn, #offset]	Load register with word	-
LSL, LSLS	Rd, Rm, <Rs #n>	Logical shift left	N, Z, C
LSR, LSRS	Rd, Rm, <Rs #n>	Logical shift right	N, Z, C
MLA	Rd, Rn, Rm, Ra	Multiply with accumulate, 32-bit result	-
MLS	Rd, Rn, Rm, Ra	Multiply and subtract, 32-bit result	-
MOV, MOVS	Rd, Op2	Move	N, Z, C
MOV, MOVW	Rd, #imm16	Move 16-bit constant	N, Z, C
MOVT	Rd, #imm16	Move top	-
MRS	Rd, spec_reg	Move from special register to general register	-
MSR	spec_reg, Rm	Move from general register to special register	N, Z, C, V
MUL, MULS	{Rd,} Rn, Rm	Multiply, 32-bit result	N, Z
MVN, MVNS	Rd, Op2	Move NOT	N, Z, C
NOP	-	No operation	-
ORN, ORNS	{Rd,} Rn, Op2	Logical OR NOT	N, Z, C

Table 2-13. Cortex-M4F Instruction Summary (continued)

Mnemonic	Operands	Brief Description	Flags
ORR, ORRS	{Rd,} Rn, Op2	Logical OR	N, Z, C
PKHTB, PKHBT	{Rd,} Rn, Rm, Op2	Pack halfword	-
POP	reglist	Pop registers from stack	-
PUSH	reglist	Push registers onto stack	-
QADD	{Rd,} Rn, Rm	Saturating add	Q
QADD16	{Rd,} Rn, Rm	Saturating add 16	-
QADD8	{Rd,} Rn, Rm	Saturating add 8	-
QASX	{Rd,} Rn, Rm	Saturating add and subtract with exchange	-
QDADD	{Rd,} Rn, Rm	Saturating double and add	Q
QDSUB	{Rd,} Rn, Rm	Saturating double and subtract	Q
QSAX	{Rd,} Rn, Rm	Saturating subtract and add with exchange	-
QSUB	{Rd,} Rn, Rm	Saturating subtract	Q
QSUB16	{Rd,} Rn, Rm	Saturating subtract 16	-
QSUB8	{Rd,} Rn, Rm	Saturating subtract 8	-
RBIT	Rd, Rn	Reverse bits	-
REV	Rd, Rn	Reverse byte order in a word	-
REV16	Rd, Rn	Reverse byte order in each halfword	-
REVSH	Rd, Rn	Reverse byte order in bottom halfword and sign extend	-
ROR, RORS	Rd, Rm, <Rs #n>	Rotate right	N, Z, C
RRX, RRXS	Rd, Rm	Rotate right with extend	N, Z, C
RSB, RSBS	{Rd,} Rn, Op2	Reverse subtract	N, Z, C, V
SADD16	{Rd,} Rn, Rm	Signed add 16	GE
SADD8	{Rd,} Rn, Rm	Signed add 8	GE
SASX	{Rd,} Rn, Rm	Signed add and subtract with exchange	GE
SBC, SBCS	{Rd,} Rn, Op2	Subtract with carry	N, Z, C, V
SBFX	Rd, Rn, #lsb, #width	Signed bit field extract	-
SDIV	{Rd,} Rn, Rm	Signed divide	-
SEL	{Rd,} Rn, Rm	Select bytes	-
SEV	-	Send event	-
SHADD16	{Rd,} Rn, Rm	Signed halving add 16	-
SHADD8	{Rd,} Rn, Rm	Signed halving add 8	-
SHASX	{Rd,} Rn, Rm	Signed halving add and subtract with exchange	-
SHSAX	{Rd,} Rn, Rm	Signed halving add and subtract with exchange	-
SHSUB16	{Rd,} Rn, Rm	Signed halving subtract 16	-
SHSUB8	{Rd,} Rn, Rm	Signed halving subtract 8	-

Table 2-13. Cortex-M4F Instruction Summary (continued)

Mnemonic	Operands	Brief Description	Flags
SMLABB, SMLABT, SMLATB, SMLATT	Rd, Rn, Rm, Ra	Signed multiply accumulate long (halfwords)	Q
SMLAD, SMLADX	Rd, Rn, Rm, Ra	Signed multiply accumulate dual	Q
SMLAL	RdLo, RdHi, Rn, Rm	Signed multiply with accumulate (32x32+64), 64-bit result	-
SMLALBB, SMLALBT, SMLALTB, SMLALTT	RdLo, RdHi, Rn, Rm	Signed multiply accumulate long (halfwords)	-
SMLALD, SMLALDX	RdLo, RdHi, Rn, Rm	Signed multiply accumulate long dual	-
SMLAWB,SMLAWT	Rd, Rn, Rm, Ra	Signed multiply accumulate, word by halfword	Q
SMLSD SMLSDX	Rd, Rn, Rm, Ra	Signed multiply subtract dual	Q
SMLSLD SMLSLDX	RdLo, RdHi, Rn, Rm	Signed multiply subtract long dual	
SMMLA	Rd, Rn, Rm, Ra	Signed most significant word multiply accumulate	-
SMMLS, SMMLR	Rd, Rn, Rm, Ra	Signed most significant word multiply subtract	-
SMMUL, SMMULR	{Rd,} Rn, Rm	Signed most significant word multiply	-
SMUAD SMUADX	{Rd,} Rn, Rm	Signed dual multiply add	Q
SMULBB, SMULBT, SMULTB, SMULTT	{Rd,} Rn, Rm	Signed multiply halfwords	-
SMULL	RdLo, RdHi, Rn, Rm	Signed multiply (32x32), 64-bit result	-
SMULWB, SMULWT	{Rd,} Rn, Rm	Signed multiply by halfword	-
SMUSD, SMUSDX	{Rd,} Rn, Rm	Signed dual multiply subtract	-
SSAT	Rd, #n, Rm {,shift #s}	Signed saturate	Q
SSAT16	Rd, #n, Rm	Signed saturate 16	Q
SSAX	{Rd,} Rn, Rm	Saturating subtract and add with exchange	GE
SSUB16	{Rd,} Rn, Rm	Signed subtract 16	-
SSUB8	{Rd,} Rn, Rm	Signed subtract 8	-
STM	Rn{!}, reglist	Store multiple registers, increment after	-

Table 2-13. Cortex-M4F Instruction Summary (continued)

Mnemonic	Operands	Brief Description	Flags
STMDB, STMEA	Rn{!}, reglist	Store multiple registers, decrement before	-
STMFD, STMIA	Rn{!}, reglist	Store multiple registers, increment after	-
STR	Rt, [Rn {, #offset}]	Store register word	-
STRB, STRBT	Rt, [Rn {, #offset}]	Store register byte	-
STRD	Rt, Rt2, [Rn {, #offset}]	Store register two words	-
STREX	Rt, Rt, [Rn {, #offset}]	Store register exclusive	-
STREXB	Rd, Rt, [Rn]	Store register exclusive byte	-
STREXH	Rd, Rt, [Rn]	Store register exclusive halfword	-
STRH, STRHT	Rt, [Rn {, #offset}]	Store register halfword	-
STRSB, STRSBT	Rt, [Rn {, #offset}]	Store register signed byte	-
STRSH, STRSHT	Rt, [Rn {, #offset}]	Store register signed halfword	-
STRT	Rt, [Rn {, #offset}]	Store register word	-
SUB, SUBS	{Rd,} Rn, Op2	Subtract	N, Z, C, V
SUB, SUBW	{Rd,} Rn, #imm12	Subtract 12-bit constant	N, Z, C, V
SVC	#imm	Supervisor call	-
SXTAB	{Rd,} Rn, Rm, {,ROR #}	Extend 8 bits to 32 and add	-
SXTAB16	{Rd,} Rn, Rm, {,ROR #}	Dual extend 8 bits to 16 and add	-
SXTAH	{Rd,} Rn, Rm, {,ROR #}	Extend 16 bits to 32 and add	-
SXTB16	{Rd,} Rm {,ROR #n}	Signed extend byte 16	-
SXTB	{Rd,} Rm {,ROR #n}	Sign extend a byte	-
SXTH	{Rd,} Rm {,ROR #n}	Sign extend a halfword	-
TBB	[Rn, Rm]	Table branch byte	-
TBH	[Rn, Rm, LSL #1]	Table branch halfword	-
TEQ	Rn, Op2	Test equivalence	N, Z, C
TST	Rn, Op2	Test	N, Z, C
UADD16	{Rd,} Rn, Rm	Unsigned add 16	GE
UADD8	{Rd,} Rn, Rm	Unsigned add 8	GE
UASX	{Rd,} Rn, Rm	Unsigned add and subtract with exchange	GE
UHADD16	{Rd,} Rn, Rm	Unsigned halving add 16	-
UHADD8	{Rd,} Rn, Rm	Unsigned halving add 8	-
UHASX	{Rd,} Rn, Rm	Unsigned halving add and subtract with exchange	-
UHSAX	{Rd,} Rn, Rm	Unsigned halving subtract and add with exchange	-
UHSUB16	{Rd,} Rn, Rm	Unsigned halving subtract 16	-
UHSUB8	{Rd,} Rn, Rm	Unsigned halving subtract 8	-
UBFX	Rd, Rn, #lsb, #width	Unsigned bit field extract	-
UDIV	{Rd,} Rn, Rm	Unsigned divide	-
UMAAL	RdLo, RdHi, Rn, Rm	Unsigned multiply accumulate accumulate long (32x32+64), 64-bit result	-

Table 2-13. Cortex-M4F Instruction Summary (continued)

Mnemonic	Operands	Brief Description	Flags
UMLAL	RdLo, RdHi, Rn, Rm	Unsigned multiply with accumulate (32x32+32+32), 64-bit result	-
UMULL	RdLo, RdHi, Rn, Rm	Unsigned multiply (32x 2), 64-bit result	-
UQADD16	{Rd,} Rn, Rm	Unsigned Saturating Add 16	-
UQADD8	{Rd,} Rn, Rm	Unsigned Saturating Add 8	-
UQASX	{Rd,} Rn, Rm	Unsigned Saturating Add and Subtract with Exchange	-
UQSAX	{Rd,} Rn, Rm	Unsigned Saturating Subtract and Add with Exchange	-
UQSUB16	{Rd,} Rn, Rm	Unsigned Saturating Subtract 16	-
UQSUB8	{Rd,} Rn, Rm	Unsigned Saturating Subtract 8	-
USAD8	{Rd,} Rn, Rm	Unsigned Sum of Absolute Differences	-
USADA8	{Rd,} Rn, Rm, Ra	Unsigned Sum of Absolute Differences and Accumulate	-
USAT	Rd, #n, Rm {,shift #s}	Unsigned Saturate	Q
USAT16	Rd, #n, Rm	Unsigned Saturate 16	Q
USAX	{Rd,} Rn, Rm	Unsigned Subtract and add with Exchange	GE
USUB16	{Rd,} Rn, Rm	Unsigned Subtract 16	GE
USUB8	{Rd,} Rn, Rm	Unsigned Subtract 8	GE
UXTAB	{Rd,} Rn, Rm, {,ROR #}	Rotate, extend 8 bits to 32 and Add	-
UXTAB16	{Rd,} Rn, Rm, {,ROR #}	Rotate, dual extend 8 bits to 16 and Add	-
UXTAH	{Rd,} Rn, Rm, {,ROR #}	Rotate, unsigned extend and Add Halfword	-
UXTB	{Rd,} Rm, {,ROR #n}	Zero extend a Byte	-
UXTB16	{Rd,} Rm, {,ROR #n}	Unsigned Extend Byte 16	-
UXTH	{Rd,} Rm, {,ROR #n}	Zero extend a Halfword	-
VABS.F32	Sd, Sm	Floating-point Absolute	-
VADD.F32	{Sd,} Sn, Sm	Floating-point Add	-
VCMP.F32	Sd, <Sm #0.0>	Compare two floating-point registers, or one floating-point register and zero	FPSCR
VCMP.E.F32	Sd, <Sm #0.0>	Compare two floating-point registers, or one floating-point register and zero with Invalid Operation check	FPSCR
VCVT.S32.F32	Sd, Sm	Convert between floating-point and integer	-
VCVT.S16.F32	Sd, Sd, #fbits	Convert between floating-point and fixed point	-
VCVTR.S32.F32	Sd, Sm	Convert between floating-point and integer with rounding	-
VCVT<B H>.F32.F16	Sd, Sm	Converts half-precision value to single-precision	-
VCVTT<B T>.F32.F16	Sd, Sm	Converts single-precision register to half-precision	-
VDIV.F32	{Sd,} Sn, Sm	Floating-point Divide	-
VFMA.F32	{Sd,} Sn, Sm	Floating-point Fused Multiply Accumulate	-

Table 2-13. Cortex-M4F Instruction Summary (continued)

Mnemonic	Operands	Brief Description	Flags
VFNMA.F32	{Sd,} Sn, Sm	Floating-point Fused Negate Multiply Accumulate	-
VFMS.F32	{Sd,} Sn, Sm	Floating-point Fused Multiply Subtract	-
VFNMS.F32	{Sd,} Sn, Sm	Floating-point Fused Negate Multiply Subtract	-
VLDM.F<32 64>	Rn{!}, list	Load Multiple extension registers	-
VLDR.F<32 64>	<Dd Sd>, [Rn]	Load an extension register from memory	-
VLMA.F32	{Sd,} Sn, Sm	Floating-point Multiply Accumulate	-
VLMS.F32	{Sd,} Sn, Sm	Floating-point Multiply Subtract	-
VMOV.F32	Sd, #imm	Floating-point Move immediate	-
VMOV	Sd, Sm	Floating-point Move register	-
VMOV	Sn, Rt	Copy ARM core register to single precision	-
VMOV	Sm, Sm1, Rt, Rt2	Copy 2 ARM core registers to 2 single precision	-
VMOV	Dd[x], Rt	Copy ARM core register to scalar	-
VMOV	Rt, Dn[x]	Copy scalar to ARM core register	-
VMRS	Rt, FPSCR	Move FPSCR to ARM core register or APSR	N, Z, C, V
VMSR	FPSCR, Rt	Move to FPSCR from ARM Core register	FPSCR
VMUL.F32	{Sd,} Sn, Sm	Floating-point Multiply	-
VNEG.F32	Sd, Sm	Floating-point Negate	-
VNMLA.F32	{Sd,} Sn, Sm	Floating-point Multiply and Add	-
VNMLS.F32	{Sd,} Sn, Sm	Floating-point Multiply and Subtract	-
VNMUL	{Sd,} Sn, Sm	Floating-point Multiply	-
VPOP	list	Pop extension registers	-
VPUSH	list	Push extension registers	-
VSQRT.F32	Sd, Sm	Calculates floating-point Square Root	-
VSTM	Rn{!}, list	Floating-point register Store Multiple	-
VSTR.F3<32 64>	Sd, [Rn]	Stores an extension register to memory	-
VSUB.F<32 64>	{Sd,} Sn, Sm	Floating-point Subtract	-
WFE	-	Wait for event	-
WFI	-	Wait for interrupt	-

3 Cortex-M4 Peripherals

This chapter provides information on the Tiva™ C Series implementation of the Cortex-M4 processor peripherals, including:

- **SysTick** (see page 142)
 - Provides a simple, 24-bit clear-on-write, decrementing, wrap-on-zero counter with a flexible control mechanism.
- **Nested Vectored Interrupt Controller (NVIC)** (see page 143)
 - Facilitates low-latency exception and interrupt handling
 - Controls power management
 - Implements system control registers
- **System Control Block (SCB)** (see page 144)
 - Provides system implementation information and system control, including configuration, control, and reporting of system exceptions.
- **Memory Protection Unit (MPU)** (see page 144)
 - Supports the standard ARMv7 Protected Memory System Architecture (PMSA) model. The MPU provides full support for protection regions, overlapping protection regions, access permissions, and exporting memory attributes to the system.
- **Floating-Point Unit (FPU)** (see page 149)
 - Fully supports single-precision add, subtract, multiply, divide, multiply and accumulate, and square root operations. It also provides conversions between fixed-point and floating-point data formats, and floating-point constant instructions.

Table 3-1 on page 141 shows the address map of the Private Peripheral Bus (PPB). Some peripheral register regions are split into two address regions, as indicated by two addresses listed.

Table 3-1. Core Peripheral Register Regions

Address	Core Peripheral	Description (see page ...)
0xE000.E010-0xE000.E01F	System Timer	142
0xE000.E100-0xE000.E4EF 0xE000.EF00-0xE000.EF03	Nested Vectored Interrupt Controller	143
0xE000.E008-0xE000.E00F 0xE000.ED00-0xE000.ED3F	System Control Block	144
0xE000.ED90-0xE000.EDB8	Memory Protection Unit	144
0xE000.EF30-0xE000.EF44	Floating Point Unit	149

3.1 Functional Description

This chapter provides information on the Tiva™ C Series implementation of the Cortex-M4 processor peripherals: SysTick, NVIC, SCB, MPU, FPU.

3.1.1 System Timer (SysTick)

Cortex-M4 includes an integrated system timer, SysTick, which provides a simple, 24-bit clear-on-write, decrementing, wrap-on-zero counter with a flexible control mechanism. The counter can be used in several different ways, for example as:

- An RTOS tick timer that fires at a programmable rate (for example, 100 Hz) and invokes a SysTick routine.
- A high-speed alarm timer using the system clock.
- A variable rate alarm or signal timer—the duration is range-dependent on the reference clock used and the dynamic range of the counter.
- A simple counter used to measure time to completion and time used.
- An internal clock source control based on missing/meeting durations. The `COUNT` bit in the **STCTRL** control and status register can be used to determine if an action completed within a set duration, as part of a dynamic clock management control loop.

The timer consists of three registers:

- **SysTick Control and Status (STCTRL)**: A control and status counter to configure its clock, enable the counter, enable the SysTick interrupt, and determine counter status.
- **SysTick Reload Value (STRELOAD)**: The reload value for the counter, used to provide the counter's wrap value.
- **SysTick Current Value (STCURRENT)**: The current value of the counter.

When enabled, the timer counts down on each clock from the reload value to zero, reloads (wraps) to the value in the **STRELOAD** register on the next clock edge, then decrements on subsequent clocks. Clearing the **STRELOAD** register disables the counter on the next wrap. When the counter reaches zero, the `COUNT` status bit is set. The `COUNT` bit clears on reads.

Writing to the **STCURRENT** register clears the register and the `COUNT` status bit. The write does not trigger the SysTick exception logic. On a read, the current value is the value of the register at the time the register is accessed.

The SysTick counter runs on the system clock. If this clock signal is stopped for low power mode, the SysTick counter stops. Ensure software uses aligned word accesses to access the SysTick registers.

The SysTick counter reload and current value are undefined at reset; the correct initialization sequence for the SysTick counter is:

1. Program the value in the **STRELOAD** register.
2. Clear the **STCURRENT** register by writing to it with any value.
3. Configure the **STCTRL** register for the required operation.

Note: When the processor is halted for debugging, the counter does not decrement.

3.1.2 Nested Vectored Interrupt Controller (NVIC)

This section describes the Nested Vectored Interrupt Controller (NVIC) and the registers it uses. The NVIC supports:

- 106 interrupts.
- A programmable priority level of 0-7 for each interrupt. A higher level corresponds to a lower priority, so level 0 is the highest interrupt priority.
- Low-latency exception and interrupt handling.
- Level and pulse detection of interrupt signals.
- Dynamic reprioritization of interrupts.
- Grouping of priority values into group priority and subpriority fields.
- Interrupt tail-chaining.
- An external Non-maskable interrupt (NMI).

The processor automatically stacks its state on exception entry and unstacks this state on exception exit, with no instruction overhead, providing low latency exception handling.

3.1.2.1 Level-Sensitive and Pulse Interrupts

The processor supports both level-sensitive and pulse interrupts. Pulse interrupts are also described as edge-triggered interrupts.

A level-sensitive interrupt is held asserted until the peripheral deasserts the interrupt signal. Typically this happens because the ISR accesses the peripheral, causing it to clear the interrupt request. A pulse interrupt is an interrupt signal sampled synchronously on the rising edge of the processor clock. To ensure the NVIC detects the interrupt, the peripheral must assert the interrupt signal for at least one clock cycle, during which the NVIC detects the pulse and latches the interrupt.

When the processor enters the ISR, it automatically removes the pending state from the interrupt (see “Hardware and Software Control of Interrupts” on page 143 for more information). For a level-sensitive interrupt, if the signal is not deasserted before the processor returns from the ISR, the interrupt becomes pending again, and the processor must execute its ISR again. As a result, the peripheral can hold the interrupt signal asserted until it no longer needs servicing.

3.1.2.2 Hardware and Software Control of Interrupts

The Cortex-M4 latches all interrupts. A peripheral interrupt becomes pending for one of the following reasons:

- The NVIC detects that the interrupt signal is High and the interrupt is not active.
- The NVIC detects a rising edge on the interrupt signal.
- Software writes to the corresponding interrupt set-pending register bit, or to the **Software Trigger Interrupt (SWTRIG)** register to make a Software-Generated Interrupt pending. See the `INT` bit in the **PEND0** register on page 163 or **SWTRIG** on page 170.

A pending interrupt remains pending until one of the following:

- The processor enters the ISR for the interrupt, changing the state of the interrupt from pending to active. Then:
 - For a level-sensitive interrupt, when the processor returns from the ISR, the NVIC samples the interrupt signal. If the signal is asserted, the state of the interrupt changes to pending, which might cause the processor to immediately re-enter the ISR. Otherwise, the state of the interrupt changes to inactive.
 - For a pulse interrupt, the NVIC continues to monitor the interrupt signal, and if this is pulsed the state of the interrupt changes to pending and active. In this case, when the processor returns from the ISR the state of the interrupt changes to pending, which might cause the processor to immediately re-enter the ISR.

If the interrupt signal is not pulsed while the processor is in the ISR, when the processor returns from the ISR the state of the interrupt changes to inactive.
- Software writes to the corresponding interrupt clear-pending register bit
 - For a level-sensitive interrupt, if the interrupt signal is still asserted, the state of the interrupt does not change. Otherwise, the state of the interrupt changes to inactive.
 - For a pulse interrupt, the state of the interrupt changes to inactive, if the state was pending or to active, if the state was active and pending.

3.1.3 System Control Block (SCB)

The System Control Block (SCB) provides system implementation information and system control, including configuration, control, and reporting of the system exceptions.

3.1.4 Memory Protection Unit (MPU)

This section describes the Memory protection unit (MPU). The MPU divides the memory map into a number of regions and defines the location, size, access permissions, and memory attributes of each region. The MPU supports independent attribute settings for each region, overlapping regions, and export of memory attributes to the system.

The memory attributes affect the behavior of memory accesses to the region. The Cortex-M4 MPU defines eight separate memory regions, 0-7, and a background region.

When memory regions overlap, a memory access is affected by the attributes of the region with the highest number. For example, the attributes for region 7 take precedence over the attributes of any region that overlaps region 7.

The background region has the same memory access attributes as the default memory map, but is accessible from privileged software only.

The Cortex-M4 MPU memory map is unified, meaning that instruction accesses and data accesses have the same region settings.

If a program accesses a memory location that is prohibited by the MPU, the processor generates a memory management fault, causing a fault exception and possibly causing termination of the process in an OS environment. In an OS environment, the kernel can update the MPU region setting dynamically based on the process to be executed. Typically, an embedded OS uses the MPU for memory protection.

Configuration of MPU regions is based on memory types (see “Memory Regions, Types and Attributes” on page 112 for more information).

Table 3-2 on page 145 shows the possible MPU region attributes. See the section called “MPU Configuration for a Tiva™ C Series Microcontroller” on page 149 for guidelines for programming a microcontroller implementation.

Table 3-2. Memory Attributes Summary

Memory Type	Description
Strongly Ordered	All accesses to Strongly Ordered memory occur in program order.
Device	Memory-mapped peripherals
Normal	Normal memory

To avoid unexpected behavior, disable the interrupts before updating the attributes of a region that the interrupt handlers might access.

Ensure software uses aligned accesses of the correct size to access MPU registers:

- Except for the **MPU Region Attribute and Size (MPUATTR)** register, all MPU registers must be accessed with aligned word accesses.
- The **MPUATTR** register can be accessed with byte or aligned halfword or word accesses.

The processor does not support unaligned accesses to MPU registers.

When setting up the MPU, and if the MPU has previously been programmed, disable unused regions to prevent any previous region settings from affecting the new MPU setup.

3.1.4.1 Updating an MPU Region

To update the attributes for an MPU region, the **MPU Region Number (MPUNUMBER)**, **MPU Region Base Address (MPUBASE)** and **MPUATTR** registers must be updated. Each register can be programmed separately or with a multiple-word write to program all of these registers. You can use the **MPUBASEx** and **MPUATTRx** aliases to program up to four regions simultaneously using an *STM* instruction.

Updating an MPU Region Using Separate Words

This example simple code configures one region:

```

; R1 = region number
; R2 = size/enable
; R3 = attributes
; R4 = address
LDR R0,=MPUNUMBER      ; 0xE000ED98, MPU region number register
STR R1, [R0, #0x0]     ; Region Number
STR R4, [R0, #0x4]     ; Region Base Address
STRH R2, [R0, #0x8]   ; Region Size and Enable
STRH R3, [R0, #0xA]   ; Region Attribute

```

Disable a region before writing new region settings to the MPU if you have previously enabled the region being changed. For example:

```

; R1 = region number
; R2 = size/enable
; R3 = attributes
; R4 = address
LDR R0,=MPUNUMBER      ; 0xE000ED98, MPU region number register

```

```

STR R1, [R0, #0x0]           ; Region Number
BIC R2, R2, #1               ; Disable
STRH R2, [R0, #0x8]         ; Region Size and Enable
STR R4, [R0, #0x4]          ; Region Base Address
STRH R3, [R0, #0xA]         ; Region Attribute
ORR R2, #1                   ; Enable
STRH R2, [R0, #0x8]         ; Region Size and Enable

```

Software must use memory barrier instructions:

- Before MPU setup, if there might be outstanding memory transfers, such as buffered writes, that might be affected by the change in MPU settings.
- After MPU setup, if it includes memory transfers that must use the new MPU settings.

However, memory barrier instructions are not required if the MPU setup process starts by entering an exception handler, or is followed by an exception return, because the exception entry and exception return mechanism cause memory barrier behavior.

Software does not need any memory barrier instructions during MPU setup, because it accesses the MPU through the Private Peripheral Bus (PPB), which is a Strongly Ordered memory region.

For example, if all of the memory access behavior is intended to take effect immediately after the programming sequence, then a DSB instruction and an ISB instruction should be used. A DSB is required after changing MPU settings, such as at the end of context switch. An ISB is required if the code that programs the MPU region or regions is entered using a branch or call. If the programming sequence is entered using a return from exception, or by taking an exception, then an ISB is not required.

Updating an MPU Region Using Multi-Word Writes

The MPU can be programmed directly using multi-word writes, depending how the information is divided. Consider the following reprogramming:

```

; R1 = region number
; R2 = address
; R3 = size, attributes in one
LDR R0, =MPUNUMBER ; 0xE000ED98, MPU region number register
STR R1, [R0, #0x0] ; Region Number
STR R2, [R0, #0x4] ; Region Base Address
STR R3, [R0, #0x8] ; Region Attribute, Size and Enable

```

An STM instruction can be used to optimize this:

```

; R1 = region number
; R2 = address
; R3 = size, attributes in one
LDR R0, =MPUNUMBER ; 0xE000ED98, MPU region number register
STM R0, {R1-R3}    ; Region number, address, attribute, size and enable

```

This operation can be done in two words for prepacked information, meaning that the **MPU Region Base Address (MPUBASE)** register (see page 204) contains the required region number and has the VALID bit set. This method can be used when the data is statically packed, for example in a boot loader:

```

; R1 = address and region number in one
; R2 = size and attributes in one
LDR R0, =MPUBASE      ; 0xE000ED9C, MPU Region Base register
STR R1, [R0, #0x0]    ; Region base address and region number combined
                        ; with VALID (bit 4) set
STR R2, [R0, #0x4]    ; Region Attribute, Size and Enable

```

Subregions

Regions of 256 bytes or more are divided into eight equal-sized subregions. Set the corresponding bit in the *SRD* field of the **MPU Region Attribute and Size (MPUATTR)** register (see page 206) to disable a subregion. The least-significant bit of the *SRD* field controls the first subregion, and the most-significant bit controls the last subregion. Disabling a subregion means another region overlapping the disabled range matches instead. If no other enabled region overlaps the disabled subregion, the MPU issues a fault.

Regions of 32, 64, and 128 bytes do not support subregions. With regions of these sizes, the *SRD* field must be configured to 0x00, otherwise the MPU behavior is unpredictable.

Example of SRD Use

Two regions with the same base address overlap. Region one is 128 KB, and region two is 512 KB. To ensure the attributes from region one apply to the first 128 KB region, configure the *SRD* field for region two to 0x03 to disable the first two subregions, as Figure 3-1 on page 147 shows.

Figure 3-1. SRD Use Example

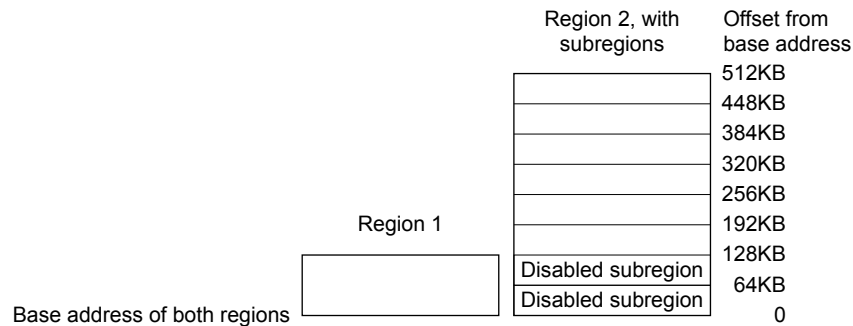

3.1.4.2 MPU Access Permission Attributes

The access permission bits, *TEX*, *S*, *C*, *B*, *AP*, and *XN* of the **MPUATTR** register, control access to the corresponding memory region. If an access is made to an area of memory without the required permissions, then the MPU generates a permission fault.

Table 3-3 on page 147 shows the encodings for the *TEX*, *C*, *B*, and *S* access permission bits. All encodings are shown for completeness, however the current implementation of the Cortex-M4 does not support the concept of cacheability or shareability. Refer to the section called “MPU Configuration for a Tiva™ C Series Microcontroller” on page 149 for information on programming the MPU for TM4C129ENCPDT implementations.

Table 3-3. TEX, S, C, and B Bit Field Encoding

TEX	S	C	B	Memory Type	Shareability	Other Attributes
000b	x ^a	0	0	Strongly Ordered	Shareable	-
000	x ^a	0	1	Device	Shareable	-

Table 3-3. TEX, S, C, and B Bit Field Encoding (continued)

TEX	S	C	B	Memory Type	Shareability	Other Attributes
000	0	1	0	Normal	Not shareable	Outer and inner write-through. No write allocate.
000	1	1	0	Normal	Shareable	
000	0	1	1	Normal	Not shareable	
000	1	1	1	Normal	Shareable	
001	0	0	0	Normal	Not shareable	Outer and inner non-cacheable.
001	1	0	0	Normal	Shareable	
001	x ^a	0	1	Reserved encoding	-	-
001	x ^a	1	0	Reserved encoding	-	-
001	0	1	1	Normal	Not shareable	Outer and inner write-back. Write and read allocate.
001	1	1	1	Normal	Shareable	
010	x ^a	0	0	Device	Not shareable	Nonshared Device.
010	x ^a	0	1	Reserved encoding	-	-
010	x ^a	1	x ^a	Reserved encoding	-	-
1BB	0	A	A	Normal	Not shareable	Cached memory (BB = outer policy, AA = inner policy). See Table 3-4 for the encoding of the AA and BB bits.
1BB	1	A	A	Normal	Shareable	

a. The MPU ignores the value of this bit.

Table 3-4 on page 148 shows the cache policy for memory attribute encodings with a **TEX** value in the range of 0x4-0x7.

Table 3-4. Cache Policy for Memory Attribute Encoding

Encoding, AA or BB	Corresponding Cache Policy
00	Non-cacheable
01	Write back, write and read allocate
10	Write through, no write allocate
11	Write back, no write allocate

Table 3-5 on page 148 shows the **AP** encodings in the **MPUATTR** register that define the access permissions for privileged and unprivileged software.

Table 3-5. AP Bit Field Encoding

AP Bit Field	Privileged Permissions	Unprivileged Permissions	Description
000	No access	No access	All accesses generate a permission fault.
001	RW	No access	Access from privileged software only.
010	RW	RO	Writes by unprivileged software generate a permission fault.
011	RW	RW	Full access.
100	Unpredictable	Unpredictable	Reserved.
101	RO	No access	Reads by privileged software only.

Table 3-5. AP Bit Field Encoding (continued)

AP Bit Field	Privileged Permissions	Unprivileged Permissions	Description
110	RO	RO	Read-only, by privileged or unprivileged software.
111	RO	RO	Read-only, by privileged or unprivileged software.

MPU Configuration for a Tiva™ C Series Microcontroller

Tiva™ C Series microcontrollers have only a single processor and no caches. As a result, the MPU should be programmed as shown in Table 3-6 on page 149.

Table 3-6. Memory Region Attributes for Tiva™ C Series Microcontrollers

Memory Region	TEX	S	C	B	Memory Type and Attributes
Flash memory	000b	0	1	0	Normal memory, non-shareable, write-through
Internal SRAM	000b	1	1	0	Normal memory, shareable, write-through
External SRAM	000b	1	1	1	Normal memory, shareable, write-back, write-allocate
Peripherals	000b	1	0	1	Device memory, shareable

In current Tiva™ C Series microcontroller implementations, the shareability and cache policy attributes do not affect the system behavior. However, using these settings for the MPU regions can make the application code more portable. The values given are for typical situations.

3.1.4.3 MPU Mismatch

When an access violates the MPU permissions, the processor generates a memory management fault (see “Exceptions and Interrupts” on page 109 for more information). The **MFAULTSTAT** register indicates the cause of the fault. See page 191 for more information.

3.1.5 Floating-Point Unit (FPU)

This section describes the Floating-Point Unit (FPU) and the registers it uses. The FPU provides:

- 32-bit instructions for single-precision (C float) data-processing operations
- Combined multiply and accumulate instructions for increased precision (Fused MAC)
- Hardware support for conversion, addition, subtraction, multiplication with optional accumulate, division, and square-root
- Hardware support for denormals and all IEEE rounding modes
- 32 dedicated 32-bit single-precision registers, also addressable as 16 double-word registers
- Decoupled three stage pipeline

The Cortex-M4F FPU fully supports single-precision add, subtract, multiply, divide, multiply and accumulate, and square root operations. It also provides conversions between fixed-point and floating-point data formats, and floating-point constant instructions. The FPU provides floating-point computation functionality that is compliant with the ANSI/IEEE Std 754-2008, IEEE Standard for Binary Floating-Point Arithmetic, referred to as the IEEE 754 standard. The FPU's single-precision extension registers can also be accessed as 16 doubleword registers for load, store, and move operations.

3.1.5.1 FPU Views of the Register Bank

The FPU provides an extension register file containing 32 single-precision registers. These can be viewed as:

- Sixteen 64-bit doubleword registers, D0-D15
- Thirty-two 32-bit single-word registers, S0-S31
- A combination of registers from the above views

Figure 3-2. FPU Register Bank



The mapping between the registers is as follows:

- $S_{\langle 2n \rangle}$ maps to the least significant half of $D_{\langle n \rangle}$
- $S_{\langle 2n+1 \rangle}$ maps to the most significant half of $D_{\langle n \rangle}$

For example, you can access the least significant half of the value in D6 by accessing S12, and the most significant half of the elements by accessing S13.

3.1.5.2 Modes of Operation

The FPU provides three modes of operation to accommodate a variety of applications.

Full-Compliance mode. In Full-Compliance mode, the FPU processes all operations according to the IEEE 754 standard in hardware.

Flush-to-Zero mode. Setting the **FZ** bit of the **Floating-Point Status and Control (FPSC)** register enables Flush-to-Zero mode. In this mode, the FPU treats all subnormal input operands of arithmetic CDP operations as zeros in the operation. Exceptions that result from a zero operand are signalled appropriately. VABS, VNEG, and VMOV are not considered arithmetic CDP operations and are not affected by Flush-to-Zero mode. A result that is tiny, as described in the IEEE 754 standard, where the destination precision is smaller in magnitude than the minimum normal value before rounding, is replaced with a zero. The **IDC** bit in **FPSC** indicates when an input flush occurs. The **UFC** bit in **FPSC** indicates when a result flush occurs.

Default NaN mode. Setting the **DN** bit in the **FPSC** register enables default NaN mode. In this mode, the result of any arithmetic data processing operation that involves an input NaN, or that generates a NaN result, returns the default NaN. Propagation of the fraction bits is maintained only by VABS,

VNEG, and VMOV operations. All other CDP operations ignore any information in the fraction bits of an input NaN.

3.1.5.3 Compliance with the IEEE 754 standard

When Default NaN (DN) and Flush-to-Zero (FZ) modes are disabled, FPv4 functionality is compliant with the IEEE 754 standard in hardware. No support code is required to achieve this compliance.

3.1.5.4 Complete Implementation of the IEEE 754 standard

The Cortex-M4F floating point instruction set does not support all operations defined in the IEEE 754-2008 standard. Unsupported operations include, but are not limited to the following:

- Remainder
- Round floating-point number to integer-valued floating-point number
- Binary-to-decimal conversions
- Decimal-to-binary conversions
- Direct comparison of single-precision and double-precision values

The Cortex-M4 FPU supports fused MAC operations as described in the IEEE standard. For complete implementation of the IEEE 754-2008 standard, floating-point functionality must be augmented with library functions.

3.1.5.5 IEEE 754 standard implementation choices

NaN handling

All single-precision values with the maximum exponent field value and a nonzero fraction field are valid NaNs. A most-significant fraction bit of zero indicates a Signaling NaN (SNaN). A one indicates a Quiet NaN (QNaN). Two NaN values are treated as different NaNs if they differ in any bit. The below table shows the default NaN values.

Sign	Fraction	Fraction
0	0xFF	bit [22] = 1, bits [21:0] are all zeros

Processing of input NaNs for ARM floating-point functionality and libraries is defined as follows:

- In full-compliance mode, NaNs are handled as described in the ARM Architecture Reference Manual. The hardware processes the NaNs directly for arithmetic CDP instructions. For data transfer operations, NaNs are transferred without raising the Invalid Operation exception. For the non-arithmetic CDP instructions, VABS, VNEG, and VMOV, NaNs are copied, with a change of sign if specified in the instructions, without causing the Invalid Operation exception.
- In default NaN mode, arithmetic CDP instructions involving NaN operands return the default NaN regardless of the fractions of any NaN operands. SNaNs in an arithmetic CDP operation set the IOC flag, FPSCR[0]. NaN handling by data transfer and non-arithmetic CDP instructions is the same as in full-compliance mode.

Table 3-7. QNaN and SNaN Handling

Instruction Type	Default NaN Mode	With QNaN Operand	With SNaN Operand
Arithmetic CDP	Off	The QNaN or one of the QNaN operands, if there is more than one, is returned according to the rules given in the ARM Architecture Reference Manual.	IOC ^a set. The SNaN is quieted and the result NaN is determined by the rules given in the ARM Architecture Reference Manual.
	On	Default NaN returns.	IOC ^a set. Default NaN returns.
Non-arithmetic CDP	Off/On	NaN passes to destination with sign changed as appropriate.	
FCMP(Z)	-	Unordered compare.	IOC set. Unordered compare.
FCMPE(Z)	-	IOC set. Unordered compare.	IOC set. Unordered compare.
Load/store	Off/On	All NaNs transferred.	

a. IOC is the Invalid Operation exception flag, FPSCR[0].

Comparisons

Comparison results modify the flags in the FPSCR. You can use the MVRS APSR_nzcv instruction (formerly FMSTAT) to transfer the current flags from the FPSCR to the APSR. See the ARM Architecture Reference Manual for mapping of IEEE 754-2008 standard predicates to ARM conditions. The flags used are chosen so that subsequent conditional execution of ARM instructions can test the predicates defined in the IEEE standard.

Underflow

The Cortex-M4F FPU uses the before rounding form of tininess and the inexact result form of loss of accuracy as described in the IEEE 754-2008 standard to generate Underflow exceptions.

In flush-to-zero mode, results that are tiny before rounding, as described in the IEEE standard, are flushed to a zero, and the UFC flag, FPSCR[3], is set. See the ARM Architecture Reference Manual for information on flush-to-zero mode.

When the FPU is not in flush-to-zero mode, operations are performed on subnormal operands. If the operation does not produce a tiny result, it returns the computed result, and the UFC flag, FPSCR[3], is not set. The IXC flag, FPSCR[4], is set if the operation is inexact. If the operation produces a tiny result, the result is a subnormal or zero value, and the UFC flag, FPSCR[3], is set if the result was also inexact.

3.1.5.6 Exceptions

The FPU sets the cumulative exception status flag in the FPSCR register as required for each instruction, in accordance with the FPv4 architecture. The FPU does not support user-mode traps. The exception enable bits in the FPSCR read-as-zero, and writes are ignored. The processor also has six output pins, FPIX, FPUFC, FPOFC, FPDZC, FPIDC, and FPIOC, that each reflect the status of one of the cumulative exception flags. For a description of these outputs, see the *ARM Cortex-M4 Integration and Implementation Manual* (ARM DII 0239, available from ARM).

The processor can reduce the exception latency by using lazy stacking. See Auxiliary Control Register, ACTLR on page 4-5. This means that the processor reserves space on the stack for the FP state, but does not save that state information to the stack. See the ARMv7-M Architecture Reference Manual (available from ARM) for more information.

3.1.5.7 Enabling the FPU

The FPU is disabled from reset. You must enable it before you can use any floating-point instructions. The processor must be in privileged mode to read from and write to the **Coprocessor Access**

Control (CPAC) register. The below example code sequence enables the FPU in both privileged and user modes.

```
; CPACR is located at address 0xE000ED88
LDR.W R0, =0xE000ED88
; Read CPACR
LDR R1, [R0]
; Set bits 20-23 to enable CP10 and CP11 coprocessors
ORR R1, R1, #(0xF << 20)
; Write back the modified value to the CPACR
STR R1, [R0]; wait for store to complete
DSB
;reset pipeline now the FPU is enabled
ISB
```

3.2 Register Map

Table 3-8 on page 153 lists the Cortex-M4 Peripheral SysTick, NVIC, MPU, FPU and SCB registers. The offset listed is a hexadecimal increment to the register's address, relative to the Core Peripherals base address of 0xE000.E000.

Note: Register spaces that are not used are reserved for future or internal use. Software should not modify any reserved memory address.

Table 3-8. Peripherals Register Map

Offset	Name	Type	Reset	Description	See page
System Timer (SysTick) Registers					
0x010	STCTRL	RW	0x0000.0000	SysTick Control and Status Register	157
0x014	STRELOAD	RW	-	SysTick Reload Value Register	159
0x018	STCURRENT	RWC	-	SysTick Current Value Register	160
Nested Vectored Interrupt Controller (NVIC) Registers					
0x100	EN0	RW	0x0000.0000	Interrupt 0-31 Set Enable	161
0x104	EN1	RW	0x0000.0000	Interrupt 32-63 Set Enable	161
0x108	EN2	RW	0x0000.0000	Interrupt 64-95 Set Enable	161
0x10C	EN3	RW	0x0000.0000	Interrupt 96-113 Set Enable	161
0x180	DIS0	RW	0x0000.0000	Interrupt 0-31 Clear Enable	162
0x184	DIS1	RW	0x0000.0000	Interrupt 32-63 Clear Enable	162
0x188	DIS2	RW	0x0000.0000	Interrupt 64-95 Clear Enable	162
0x18C	DIS3	RW	0x0000.0000	Interrupt 96-113 Clear Enable	162
0x200	PEND0	RW	0x0000.0000	Interrupt 0-31 Set Pending	163
0x204	PEND1	RW	0x0000.0000	Interrupt 32-63 Set Pending	163
0x208	PEND2	RW	0x0000.0000	Interrupt 64-95 Set Pending	163
0x20C	PEND3	RW	0x0000.0000	Interrupt 96-113 Set Pending	163

Table 3-8. Peripherals Register Map (continued)

Offset	Name	Type	Reset	Description	See page
0x280	UNPEND0	RW	0x0000.0000	Interrupt 0-31 Clear Pending	164
0x284	UNPEND1	RW	0x0000.0000	Interrupt 32-63 Clear Pending	164
0x288	UNPEND2	RW	0x0000.0000	Interrupt 64-95 Clear Pending	164
0x28C	UNPEND3	RW	0x0000.0000	Interrupt 96-113 Clear Pending	164
0x300	ACTIVE0	RO	0x0000.0000	Interrupt 0-31 Active Bit	165
0x304	ACTIVE1	RO	0x0000.0000	Interrupt 32-63 Active Bit	165
0x308	ACTIVE2	RO	0x0000.0000	Interrupt 64-95 Active Bit	165
0x30C	ACTIVE3	RO	0x0000.0000	Interrupt 96-127 Active Bit	165
0x400	PRI0	RW	0x0000.0000	Interrupt 0-3 Priority	166
0x404	PRI1	RW	0x0000.0000	Interrupt 4-7 Priority	166
0x408	PRI2	RW	0x0000.0000	Interrupt 8-11 Priority	166
0x40C	PRI3	RW	0x0000.0000	Interrupt 12-15 Priority	166
0x410	PRI4	RW	0x0000.0000	Interrupt 16-19 Priority	166
0x414	PRI5	RW	0x0000.0000	Interrupt 20-23 Priority	166
0x418	PRI6	RW	0x0000.0000	Interrupt 24-27 Priority	166
0x41C	PRI7	RW	0x0000.0000	Interrupt 28-31 Priority	166
0x420	PRI8	RW	0x0000.0000	Interrupt 32-35 Priority	166
0x424	PRI9	RW	0x0000.0000	Interrupt 36-39 Priority	166
0x428	PRI10	RW	0x0000.0000	Interrupt 40-43 Priority	166
0x42C	PRI11	RW	0x0000.0000	Interrupt 44-47 Priority	166
0x430	PRI12	RW	0x0000.0000	Interrupt 48-51 Priority	166
0x434	PRI13	RW	0x0000.0000	Interrupt 52-55 Priority	166
0x438	PRI14	RW	0x0000.0000	Interrupt 56-59 Priority	166
0x43C	PRI15	RW	0x0000.0000	Interrupt 60-63 Priority	166
0x440	PRI16	RW	0x0000.0000	Interrupt 64-67 Priority	168
0x444	PRI17	RW	0x0000.0000	Interrupt 68-71 Priority	168
0x448	PRI18	RW	0x0000.0000	Interrupt 72-75 Priority	168
0x44C	PRI19	RW	0x0000.0000	Interrupt 76-79 Priority	168
0x450	PRI20	RW	0x0000.0000	Interrupt 80-83 Priority	168
0x454	PRI21	RW	0x0000.0000	Interrupt 84-87 Priority	168
0x458	PRI22	RW	0x0000.0000	Interrupt 88-91 Priority	168
0x45C	PRI23	RW	0x0000.0000	Interrupt 92-95 Priority	168

Table 3-8. Peripherals Register Map (continued)

Offset	Name	Type	Reset	Description	See page
0x460	PRI24	RW	0x0000.0000	Interrupt 96-99 Priority	168
0x464	PRI25	RW	0x0000.0000	Interrupt 100-103 Priority	168
0x468	PRI26	RW	0x0000.0000	Interrupt 104-107 Priority	168
0x46C	PRI27	RW	0x0000.0000	Interrupt 108-111 Priority	168
0x470	PRI28	RW	0x0000.0000	Interrupt 112-113 Priority	168
0xF00	SWTRIG	WO	0x0000.0000	Software Trigger Interrupt	170
System Control Block (SCB) Registers					
0x008	ACTLR	RW	0x0000.0000	Auxiliary Control	171
0xD00	CPUID	RO	0x410F.C241	CPU ID Base	173
0xD04	INTCTRL	RW	0x0000.0000	Interrupt Control and State	174
0xD08	VTABLE	RW	0x0000.0000	Vector Table Offset	177
0xD0C	APINT	RW	0xFA05.0000	Application Interrupt and Reset Control	178
0xD10	SYSCTRL	RW	0x0000.0000	System Control	180
0xD14	CFGCTRL	RW	0x0000.0200	Configuration and Control	182
0xD18	SYSPRI1	RW	0x0000.0000	System Handler Priority 1	184
0xD1C	SYSPRI2	RW	0x0000.0000	System Handler Priority 2	185
0xD20	SYSPRI3	RW	0x0000.0000	System Handler Priority 3	186
0xD24	SYSHNDCTRL	RW	0x0000.0000	System Handler Control and State	187
0xD28	FAULTSTAT	RW1C	0x0000.0000	Configurable Fault Status	191
0xD2C	HFAULTSTAT	RW1C	0x0000.0000	Hard Fault Status	197
0xD34	MMADDR	RW	-	Memory Management Fault Address	198
0xD38	FAULTADDR	RW	-	Bus Fault Address	199
Memory Protection Unit (MPU) Registers					
0xD90	MPUTYPE	RO	0x0000.0800	MPU Type	200
0xD94	MPUCTRL	RW	0x0000.0000	MPU Control	201
0xD98	MPUNUMBER	RW	0x0000.0000	MPU Region Number	203
0xD9C	MPUBASE	RW	0x0000.0000	MPU Region Base Address	204
0xDA0	MPUATTR	RW	0x0000.0000	MPU Region Attribute and Size	206
0xDA4	MPUBASE1	RW	0x0000.0000	MPU Region Base Address Alias 1	204
0xDA8	MPUATTR1	RW	0x0000.0000	MPU Region Attribute and Size Alias 1	206
0xDAC	MPUBASE2	RW	0x0000.0000	MPU Region Base Address Alias 2	204
0xDB0	MPUATTR2	RW	0x0000.0000	MPU Region Attribute and Size Alias 2	206

Table 3-8. Peripherals Register Map (*continued*)

Offset	Name	Type	Reset	Description	See page
0xDB4	MPUBASE3	RW	0x0000.0000	MPU Region Base Address Alias 3	204
0xDB8	MPUATTR3	RW	0x0000.0000	MPU Region Attribute and Size Alias 3	206
Floating-Point Unit (FPU) Registers					
0xD88	CPAC	RW	0x0000.0000	Coprocessor Access Control	209
0xF34	FPCC	RW	0xC000.0000	Floating-Point Context Control	210
0xF38	FPCA	RW	-	Floating-Point Context Address	212
0xF3C	FPDSC	RW	0x0000.0000	Floating-Point Default Status Control	213

3.3 System Timer (SysTick) Register Descriptions

This section lists and describes the System Timer registers, in numerical order by address offset.

Register 1: SysTick Control and Status Register (STCTRL), offset 0x010

Note: This register can only be accessed from privileged mode.

The SysTick **STCTRL** register enables the SysTick features.

SysTick Control and Status Register (STCTRL)

Base 0xE000.E000

Offset 0x010

Type RW, reset 0x0000.0000

	31	30	29	28	27	26	25	24	23	22	21	20	19	18	17	16	
	reserved															COUNT	
Type	RO	RO	RO	RO	RO	RO	RO	RO	RO	RO	RO	RO	RO	RO	RO	RO	
Reset	0	0	0	0	0	0	0	0	0	0	0	0	0	0	0	0	
	15	14	13	12	11	10	9	8	7	6	5	4	3	2	1	0	
	reserved													CLK_SRC	INTEN	ENABLE	
Type	RO	RO	RO	RO	RO	RO	RO	RO	RO	RO	RO	RO	RO	RO	RW	RW	RW
Reset	0	0	0	0	0	0	0	0	0	0	0	0	0	0	0	0	0

Bit/Field	Name	Type	Reset	Description						
31:17	reserved	RO	0x000	Software should not rely on the value of a reserved bit. To provide compatibility with future products, the value of a reserved bit should be preserved across a read-modify-write operation.						
16	COUNT	RO	0	Count Flag						
				<table border="0"> <tr> <td>Value</td> <td>Description</td> </tr> <tr> <td>0</td> <td>The SysTick timer has not counted to 0 since the last time this bit was read.</td> </tr> <tr> <td>1</td> <td>The SysTick timer has counted to 0 since the last time this bit was read.</td> </tr> </table> <p>This bit is cleared by a read of the register or if the STCURRENT register is written with any value.</p> <p>If read by the debugger using the DAP, this bit is cleared only if the MasterType bit in the AHB-AP Control Register is clear. Otherwise, the COUNT bit is not changed by the debugger read. See the <i>ARM® Debug Interface V5 Architecture Specification</i> for more information on MasterType.</p>	Value	Description	0	The SysTick timer has not counted to 0 since the last time this bit was read.	1	The SysTick timer has counted to 0 since the last time this bit was read.
Value	Description									
0	The SysTick timer has not counted to 0 since the last time this bit was read.									
1	The SysTick timer has counted to 0 since the last time this bit was read.									
15:3	reserved	RO	0x000	Software should not rely on the value of a reserved bit. To provide compatibility with future products, the value of a reserved bit should be preserved across a read-modify-write operation.						
2	CLK_SRC	RW	0	Clock Source						
				<table border="0"> <tr> <td>Value</td> <td>Description</td> </tr> <tr> <td>0</td> <td>Precision internal oscillator (PIOSC) divided by 4</td> </tr> <tr> <td>1</td> <td>System clock</td> </tr> </table>	Value	Description	0	Precision internal oscillator (PIOSC) divided by 4	1	System clock
Value	Description									
0	Precision internal oscillator (PIOSC) divided by 4									
1	System clock									

Bit/Field	Name	Type	Reset	Description
1	INTEN	RW	0	Interrupt Enable Value Description 0 Interrupt generation is disabled. Software can use the <code>COUNT</code> bit to determine if the counter has ever reached 0. 1 An interrupt is generated to the NVIC when SysTick counts to 0.
0	ENABLE	RW	0	Enable Value Description 0 The counter is disabled. 1 Enables SysTick to operate in a multi-shot way. That is, the counter loads the <code>RELOAD</code> value and begins counting down. On reaching 0, the <code>COUNT</code> bit is set and an interrupt is generated if enabled by <code>INTEN</code> . The counter then loads the <code>RELOAD</code> value again and begins counting.

Register 2: SysTick Reload Value Register (STRELOAD), offset 0x014

Note: This register can only be accessed from privileged mode.

The **STRELOAD** register specifies the start value to load into the **SysTick Current Value (STCURRENT)** register when the counter reaches 0. The start value can be between 0x1 and 0x00FF.FFFF. A start value of 0 is possible but has no effect because the SysTick interrupt and the **COUNT** bit are activated when counting from 1 to 0.

SysTick can be configured as a multi-shot timer, repeated over and over, firing every N+1 clock pulses, where N is any value from 1 to 0x00FF.FFFF. For example, if a tick interrupt is required every 100 clock pulses, 99 must be written into the **RELOAD** field.

Note that in order to access this register correctly, the system clock must be faster than 8 MHz.

SysTick Reload Value Register (STRELOAD)

Base 0xE000.E000

Offset 0x014

Type RW, reset -

	31	30	29	28	27	26	25	24	23	22	21	20	19	18	17	16
	reserved								RELOAD							
Type	RO	RO	RO	RO	RO	RO	RO	RO	RW	RW	RW	RW	RW	RW	RW	RW
Reset	0	0	0	0	0	0	0	0	0	0	0	0	0	0	0	0
	15	14	13	12	11	10	9	8	7	6	5	4	3	2	1	0
	RELOAD															
Type	RW	RW	RW	RW	RW	RW	RW	RW	RW	RW	RW	RW	RW	RW	RW	RW
Reset	0	0	0	0	0	0	0	0	0	0	0	0	0	0	0	0

Bit/Field	Name	Type	Reset	Description
31:24	reserved	RO	0x00	Software should not rely on the value of a reserved bit. To provide compatibility with future products, the value of a reserved bit should be preserved across a read-modify-write operation.
23:0	RELOAD	RW	0x00.0000	Reload Value Value to load into the SysTick Current Value (STCURRENT) register when the counter reaches 0.

Register 3: SysTick Current Value Register (STCURRENT), offset 0x018

Note: This register can only be accessed from privileged mode.

The **STCURRENT** register contains the current value of the SysTick counter.

SysTick Current Value Register (STCURRENT)

Base 0xE000.E000

Offset 0x018

Type RWC, reset -

	31	30	29	28	27	26	25	24	23	22	21	20	19	18	17	16
	reserved								CURRENT							
Type	RO	RO	RO	RO	RO	RO	RO	RO	RWC	RWC	RWC	RWC	RWC	RWC	RWC	RWC
Reset	0	0	0	0	0	0	0	0	0	0	0	0	0	0	0	0
	15	14	13	12	11	10	9	8	7	6	5	4	3	2	1	0
	CURRENT															
Type	RWC	RWC	RWC	RWC	RWC	RWC	RWC	RWC	RWC	RWC	RWC	RWC	RWC	RWC	RWC	RWC
Reset	0	0	0	0	0	0	0	0	0	0	0	0	0	0	0	0

Bit/Field	Name	Type	Reset	Description
31:24	reserved	RO	0x00	Software should not rely on the value of a reserved bit. To provide compatibility with future products, the value of a reserved bit should be preserved across a read-modify-write operation.
23:0	CURRENT	RWC	0x00.0000	Current Value This field contains the current value at the time the register is accessed. No read-modify-write protection is provided, so change with care. This register is write-clear. Writing to it with any value clears the register. Clearing this register also clears the <code>COUNT</code> bit of the STCTRL register.

3.4 NVIC Register Descriptions

This section lists and describes the NVIC registers, in numerical order by address offset.

The NVIC registers can only be fully accessed from privileged mode, but interrupts can be pended while in unprivileged mode by enabling the **Configuration and Control (CFGCTRL)** register. Any other unprivileged mode access causes a bus fault.

Ensure software uses correctly aligned register accesses. The processor does not support unaligned accesses to NVIC registers.

An interrupt can enter the pending state even if it is disabled.

Before programming the **VTABLE** register to relocate the vector table, ensure the vector table entries of the new vector table are set up for fault handlers, NMI, and all enabled exceptions such as interrupts. For more information, see page 177.

Register 4: Interrupt 0-31 Set Enable (EN0), offset 0x100**Register 5: Interrupt 32-63 Set Enable (EN1), offset 0x104****Register 6: Interrupt 64-95 Set Enable (EN2), offset 0x108****Register 7: Interrupt 96-113 Set Enable (EN3), offset 0x10C**

Note: This register can only be accessed from privileged mode.

The **ENn** registers enable interrupts and show which interrupts are enabled. Bit 0 of **EN0** corresponds to Interrupt 0; bit 31 corresponds to Interrupt 31. Bit 0 of **EN1** corresponds to Interrupt 32; bit 31 corresponds to Interrupt 63. Bit 0 of **EN2** corresponds to Interrupt 64; bit 31 corresponds to Interrupt 95. Bit 0 of **EN3** corresponds to Interrupt 96; bit 17 corresponds to Interrupt 113.

See Table 2-9 on page 122 for interrupt assignments.

If a pending interrupt is enabled, the NVIC activates the interrupt based on its priority. If an interrupt is not enabled, asserting its interrupt signal changes the interrupt state to pending, but the NVIC never activates the interrupt, regardless of its priority.

Interrupt 0-31 Set Enable (EN0)

Base 0xE000.E000

Offset 0x100

Type RW, reset 0x0000.0000

	31	30	29	28	27	26	25	24	23	22	21	20	19	18	17	16
	INT															
Type	RW	RW	RW	RW	RW	RW	RW	RW	RW	RW	RW	RW	RW	RW	RW	RW
Reset	0	0	0	0	0	0	0	0	0	0	0	0	0	0	0	0
	15	14	13	12	11	10	9	8	7	6	5	4	3	2	1	0
	INT															
Type	RW	RW	RW	RW	RW	RW	RW	RW	RW	RW	RW	RW	RW	RW	RW	RW
Reset	0	0	0	0	0	0	0	0	0	0	0	0	0	0	0	0

Bit/Field	Name	Type	Reset	Description
31:0	INT	RW	0x0000.0000	Interrupt Enable

Value	Description
0	On a read, indicates the interrupt is disabled. On a write, no effect.
1	On a read, indicates the interrupt is enabled. On a write, enables the interrupt.

A bit can only be cleared by setting the corresponding `INT[n]` bit in the **DISn** register.

Register 8: Interrupt 0-31 Clear Enable (DIS0), offset 0x180

Register 9: Interrupt 32-63 Clear Enable (DIS1), offset 0x184

Register 10: Interrupt 64-95 Clear Enable (DIS2), offset 0x188

Register 11: Interrupt 96-113 Clear Enable (DIS3), offset 0x18C

Note: This register can only be accessed from privileged mode.

The **DIS_n** registers disable interrupts. Bit 0 of **DIS0** corresponds to Interrupt 0; bit 31 corresponds to Interrupt 31. Bit 0 of **DIS1** corresponds to Interrupt 32; bit 31 corresponds to Interrupt 63. Bit 0 of **DIS2** corresponds to Interrupt 64; bit 31 corresponds to Interrupt 95. Bit 0 of **DIS3** corresponds to Interrupt 96; .

See Table 2-9 on page 122 for interrupt assignments.

Interrupt 0-31 Clear Enable (DIS0)

Base 0xE000.E000
 Offset 0x180
 Type RW, reset 0x0000.0000

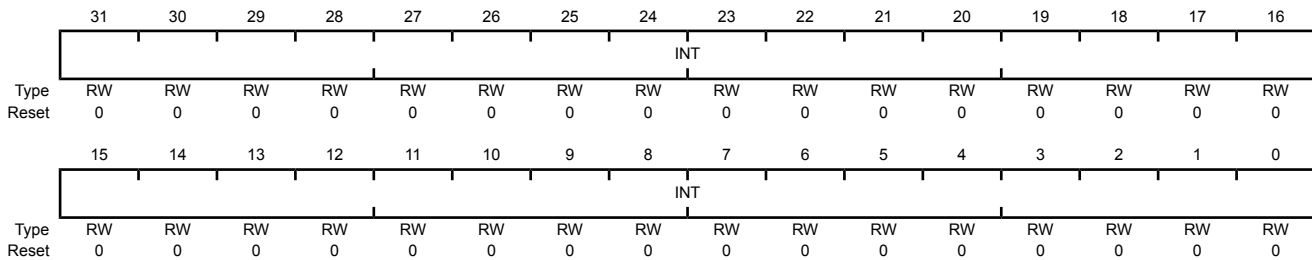

Bit/Field	Name	Type	Reset	Description
31:0	INT	RW	0x0000.0000	Interrupt Disable

Value	Description
0	On a read, indicates the interrupt is disabled. On a write, no effect.
1	On a read, indicates the interrupt is enabled. On a write, clears the corresponding INT[n] bit in the EN0 register, disabling interrupt [n].

Register 12: Interrupt 0-31 Set Pending (PEND0), offset 0x200**Register 13: Interrupt 32-63 Set Pending (PEND1), offset 0x204****Register 14: Interrupt 64-95 Set Pending (PEND2), offset 0x208****Register 15: Interrupt 96-113 Set Pending (PEND3), offset 0x20C**

Note: This register can only be accessed from privileged mode.

The **PEND_n** registers force interrupts into the pending state and show which interrupts are pending. Bit 0 of **PEND0** corresponds to Interrupt 0; bit 31 corresponds to Interrupt 31. Bit 0 of **PEND1** corresponds to Interrupt 32; bit 31 corresponds to Interrupt 63. Bit 0 of **PEND2** corresponds to Interrupt 64; bit 31 corresponds to Interrupt 95. Bit 0 of **PEND3** corresponds to Interrupt 96; bit 17 corresponds to interrupt 113.

See Table 2-9 on page 122 for interrupt assignments.

Interrupt 0-31 Set Pending (PEND0)

Base 0xE000.E000

Offset 0x200

Type RW, reset 0x0000.0000

	31	30	29	28	27	26	25	24	23	22	21	20	19	18	17	16
	INT															
Type	RW	RW	RW	RW	RW	RW	RW	RW	RW	RW	RW	RW	RW	RW	RW	RW
Reset	0	0	0	0	0	0	0	0	0	0	0	0	0	0	0	0
	15	14	13	12	11	10	9	8	7	6	5	4	3	2	1	0
	INT															
Type	RW	RW	RW	RW	RW	RW	RW	RW	RW	RW	RW	RW	RW	RW	RW	RW
Reset	0	0	0	0	0	0	0	0	0	0	0	0	0	0	0	0

Bit/Field	Name	Type	Reset	Description
31:0	INT	RW	0x0000.0000	Interrupt Set Pending
	Value	Description		
	0	On a read, indicates that the interrupt is not pending. On a write, no effect.		
	1	On a read, indicates that the interrupt is pending. On a write, the corresponding interrupt is set to pending even if it is disabled.		
	If the corresponding interrupt is already pending, setting a bit has no effect.			
	A bit can only be cleared by setting the corresponding INT[n] bit in the UNPEND0 register.			

Register 16: Interrupt 0-31 Clear Pending (UNPEND0), offset 0x280

Register 17: Interrupt 32-63 Clear Pending (UNPEND1), offset 0x284

Register 18: Interrupt 64-95 Clear Pending (UNPEND2), offset 0x288

Register 19: Interrupt 96-113 Clear Pending (UNPEND3), offset 0x28C

Note: This register can only be accessed from privileged mode.

The **UNPEND_n** registers show which interrupts are pending and remove the pending state from interrupts. Bit 0 of **UNPEND0** corresponds to Interrupt 0; bit 31 corresponds to Interrupt 31. Bit 0 of **UNPEND1** corresponds to Interrupt 32; bit 31 corresponds to Interrupt 63. Bit 0 of **UNPEND2** corresponds to Interrupt 64; bit 31 corresponds to Interrupt 95. Bit 0 of **UNPEND3** corresponds to Interrupt 96; bit 31 corresponds to Interrupt 113.

See Table 2-9 on page 122 for interrupt assignments.

Interrupt 0-31 Clear Pending (UNPEND0)

Base 0xE000.E000
Offset 0x280
Type RW, reset 0x0000.0000

	31	30	29	28	27	26	25	24	23	22	21	20	19	18	17	16
	INT															
Type	RW	RW	RW	RW	RW	RW	RW	RW	RW	RW	RW	RW	RW	RW	RW	RW
Reset	0	0	0	0	0	0	0	0	0	0	0	0	0	0	0	0
	15	14	13	12	11	10	9	8	7	6	5	4	3	2	1	0
	INT															
Type	RW	RW	RW	RW	RW	RW	RW	RW	RW	RW	RW	RW	RW	RW	RW	RW
Reset	0	0	0	0	0	0	0	0	0	0	0	0	0	0	0	0

Bit/Field	Name	Type	Reset	Description
31:0	INT	RW	0x0000.0000	Interrupt Clear Pending

Value Description

0 On a read, indicates that the interrupt is not pending.
On a write, no effect.

1 On a read, indicates that the interrupt is pending.
On a write, clears the corresponding **INT[n]** bit in the **PEND0** register, so that interrupt [n] is no longer pending.
Setting a bit does not affect the active state of the corresponding interrupt.

Register 20: Interrupt 0-31 Active Bit (ACTIVE0), offset 0x300

Register 21: Interrupt 32-63 Active Bit (ACTIVE1), offset 0x304

Register 22: Interrupt 64-95 Active Bit (ACTIVE2), offset 0x308

Register 23: Interrupt 96-127 Active Bit (ACTIVE3), offset 0x30C

Note: This register can only be accessed from privileged mode.

The **UNPEND_n** registers indicate which interrupts are active. Bit 0 of **ACTIVE0** corresponds to Interrupt 0; bit 31 corresponds to Interrupt 31. Bit 0 of **ACTIVE1** corresponds to Interrupt 32; bit 31 corresponds to Interrupt 63. Bit 0 of **ACTIVE2** corresponds to Interrupt 64; bit 31 corresponds to Interrupt 95. Bit 0 of **ACTIVE3** corresponds to Interrupt 96; bit 17 corresponds to Interrupt 113.

See Table 2-9 on page 122 for interrupt assignments.

Caution – Do not manually set or clear the bits in this register.

Interrupt 0-31 Active Bit (ACTIVE0)

Base 0xE000.E000

Offset 0x300

Type RO, reset 0x0000.0000

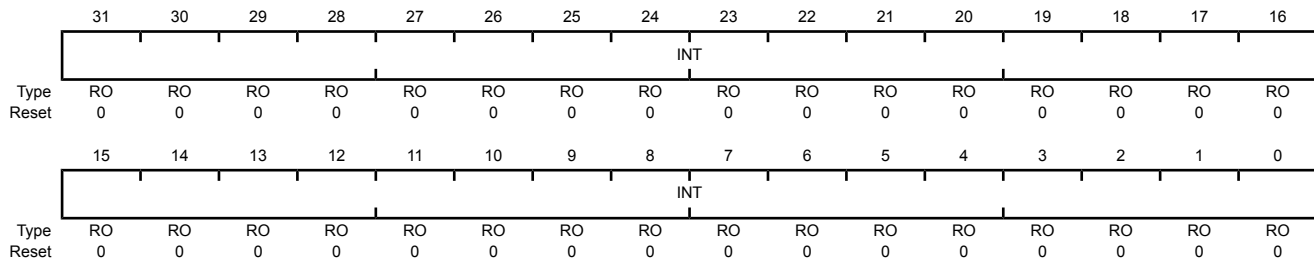

Bit/Field	Name	Type	Reset	Description
31:0	INT	RO	0x0000.0000	Interrupt Active

Value Description

Value	Description
0	The corresponding interrupt is not active.
1	The corresponding interrupt is active, or active and pending.

- Register 24: Interrupt 0-3 Priority (PRI0), offset 0x400**
Register 25: Interrupt 4-7 Priority (PRI1), offset 0x404
Register 26: Interrupt 8-11 Priority (PRI2), offset 0x408
Register 27: Interrupt 12-15 Priority (PRI3), offset 0x40C
Register 28: Interrupt 16-19 Priority (PRI4), offset 0x410
Register 29: Interrupt 20-23 Priority (PRI5), offset 0x414
Register 30: Interrupt 24-27 Priority (PRI6), offset 0x418
Register 31: Interrupt 28-31 Priority (PRI7), offset 0x41C
Register 32: Interrupt 32-35 Priority (PRI8), offset 0x420
Register 33: Interrupt 36-39 Priority (PRI9), offset 0x424
Register 34: Interrupt 40-43 Priority (PRI10), offset 0x428
Register 35: Interrupt 44-47 Priority (PRI11), offset 0x42C
Register 36: Interrupt 48-51 Priority (PRI12), offset 0x430
Register 37: Interrupt 52-55 Priority (PRI13), offset 0x434
Register 38: Interrupt 56-59 Priority (PRI14), offset 0x438
Register 39: Interrupt 60-63 Priority (PRI15), offset 0x43C

Note: This register can only be accessed from privileged mode.

The **PRI_n** registers (see also page 168) provide 3-bit priority fields for each interrupt. These registers are byte accessible. Each register holds four priority fields that are assigned to interrupts as follows:

PRI_n Register Bit Field	Interrupt
Bits 31:29	Interrupt [4n+3]
Bits 23:21	Interrupt [4n+2]
Bits 15:13	Interrupt [4n+1]
Bits 7:5	Interrupt [4n]

See Table 2-9 on page 122 for interrupt assignments.

Each priority level can be split into separate group priority and subpriority fields. The **PRI_{GROUP}** field in the **Application Interrupt and Reset Control (APINT)** register (see page 178) indicates the position of the binary point that splits the priority and subpriority fields.

These registers can only be accessed from privileged mode.

Interrupt 0-3 Priority (PRIO)

Base 0xE000.E000

Offset 0x400

Type RW, reset 0x0000.0000

	31	30	29	28	27	26	25	24	23	22	21	20	19	18	17	16
	INTD			reserved				INTC			reserved					
Type	RW	RW	RW	RO	RO	RO	RO	RO	RW	RW	RW	RO	RO	RO	RO	RO
Reset	0	0	0	0	0	0	0	0	0	0	0	0	0	0	0	0
	15	14	13	12	11	10	9	8	7	6	5	4	3	2	1	0
	INTB			reserved				INTA			reserved					
Type	RW	RW	RW	RO	RO	RO	RO	RO	RW	RW	RW	RO	RO	RO	RO	RO
Reset	0	0	0	0	0	0	0	0	0	0	0	0	0	0	0	0

Bit/Field	Name	Type	Reset	Description
31:29	INTD	RW	0x0	Interrupt Priority for Interrupt [4n+3] This field holds a priority value, 0-7, for the interrupt with the number [4n+3], where n is the number of the Interrupt Priority register (n=0 for PRIO , and so on). The lower the value, the greater the priority of the corresponding interrupt.
28:24	reserved	RO	0x0	Software should not rely on the value of a reserved bit. To provide compatibility with future products, the value of a reserved bit should be preserved across a read-modify-write operation.
23:21	INTC	RW	0x0	Interrupt Priority for Interrupt [4n+2] This field holds a priority value, 0-7, for the interrupt with the number [4n+2], where n is the number of the Interrupt Priority register (n=0 for PRIO , and so on). The lower the value, the greater the priority of the corresponding interrupt.
20:16	reserved	RO	0x0	Software should not rely on the value of a reserved bit. To provide compatibility with future products, the value of a reserved bit should be preserved across a read-modify-write operation.
15:13	INTB	RW	0x0	Interrupt Priority for Interrupt [4n+1] This field holds a priority value, 0-7, for the interrupt with the number [4n+1], where n is the number of the Interrupt Priority register (n=0 for PRIO , and so on). The lower the value, the greater the priority of the corresponding interrupt.
12:8	reserved	RO	0x0	Software should not rely on the value of a reserved bit. To provide compatibility with future products, the value of a reserved bit should be preserved across a read-modify-write operation.
7:5	INTA	RW	0x0	Interrupt Priority for Interrupt [4n] This field holds a priority value, 0-7, for the interrupt with the number [4n], where n is the number of the Interrupt Priority register (n=0 for PRIO , and so on). The lower the value, the greater the priority of the corresponding interrupt.
4:0	reserved	RO	0x0	Software should not rely on the value of a reserved bit. To provide compatibility with future products, the value of a reserved bit should be preserved across a read-modify-write operation.

- Register 40: Interrupt 64-67 Priority (PRI16), offset 0x440**
Register 41: Interrupt 68-71 Priority (PRI17), offset 0x444
Register 42: Interrupt 72-75 Priority (PRI18), offset 0x448
Register 43: Interrupt 76-79 Priority (PRI19), offset 0x44C
Register 44: Interrupt 80-83 Priority (PRI20), offset 0x450
Register 45: Interrupt 84-87 Priority (PRI21), offset 0x454
Register 46: Interrupt 88-91 Priority (PRI22), offset 0x458
Register 47: Interrupt 92-95 Priority (PRI23), offset 0x45C
Register 48: Interrupt 96-99 Priority (PRI24), offset 0x460
Register 49: Interrupt 100-103 Priority (PRI25), offset 0x464
Register 50: Interrupt 104-107 Priority (PRI26), offset 0x468
Register 51: Interrupt 108-111 Priority (PRI27), offset 0x46C
Register 52: Interrupt 112-113 Priority (PRI28), offset 0x470

Note: This register can only be accessed from privileged mode.

The **PRIn** registers (see also page 166) provide 3-bit priority fields for each interrupt. These registers are byte accessible. Each register holds four priority fields that are assigned to interrupts as follows:

PRIn Register Bit Field	Interrupt
Bits 31:29	Interrupt [4n+3]
Bits 23:21	Interrupt [4n+2]
Bits 15:13	Interrupt [4n+1]
Bits 7:5	Interrupt [4n]

See Table 2-9 on page 122 for interrupt assignments.

Each priority level can be split into separate group priority and subpriority fields. The **PRIGROUP** field in the **Application Interrupt and Reset Control (APINT)** register (see page 178) indicates the position of the binary point that splits the priority and subpriority fields .

These registers can only be accessed from privileged mode.

Note: Because the last interrupt vector is number 113, bits [31:16] of the **PRI28** register are reserved.

Interrupt 64-67 Priority (PRI16)

Base 0xE000.E000

Offset 0x440

Type RW, reset 0x0000.0000

	31	30	29	28	27	26	25	24	23	22	21	20	19	18	17	16
	INTD			reserved				INTC			reserved					
Type	RW	RW	RW	RO	RO	RO	RO	RO	RW	RW	RW	RO	RO	RO	RO	RO
Reset	0	0	0	0	0	0	0	0	0	0	0	0	0	0	0	0
	15	14	13	12	11	10	9	8	7	6	5	4	3	2	1	0
	INTB			reserved				INTA			reserved					
Type	RW	RW	RW	RO	RO	RO	RO	RO	RW	RW	RW	RO	RO	RO	RO	RO
Reset	0	0	0	0	0	0	0	0	0	0	0	0	0	0	0	0

Bit/Field	Name	Type	Reset	Description
31:29	INTD	RW	0x0	Interrupt Priority for Interrupt [4n+3] This field holds a priority value, 0-7, for the interrupt with the number [4n+3], where n is the number of the Interrupt Priority register (n=0 for PRI0 , and so on). The lower the value, the greater the priority of the corresponding interrupt.
28:24	reserved	RO	0x0	Software should not rely on the value of a reserved bit. To provide compatibility with future products, the value of a reserved bit should be preserved across a read-modify-write operation.
23:21	INTC	RW	0x0	Interrupt Priority for Interrupt [4n+2] This field holds a priority value, 0-7, for the interrupt with the number [4n+2], where n is the number of the Interrupt Priority register (n=0 for PRI0 , and so on). The lower the value, the greater the priority of the corresponding interrupt.
20:16	reserved	RO	0x0	Software should not rely on the value of a reserved bit. To provide compatibility with future products, the value of a reserved bit should be preserved across a read-modify-write operation.
15:13	INTB	RW	0x0	Interrupt Priority for Interrupt [4n+1] This field holds a priority value, 0-7, for the interrupt with the number [4n+1], where n is the number of the Interrupt Priority register (n=0 for PRI0 , and so on). The lower the value, the greater the priority of the corresponding interrupt.
12:8	reserved	RO	0x0	Software should not rely on the value of a reserved bit. To provide compatibility with future products, the value of a reserved bit should be preserved across a read-modify-write operation.
7:5	INTA	RW	0x0	Interrupt Priority for Interrupt [4n] This field holds a priority value, 0-7, for the interrupt with the number [4n], where n is the number of the Interrupt Priority register (n=0 for PRI0 , and so on). The lower the value, the greater the priority of the corresponding interrupt.
4:0	reserved	RO	0x0	Software should not rely on the value of a reserved bit. To provide compatibility with future products, the value of a reserved bit should be preserved across a read-modify-write operation.

Register 53: Software Trigger Interrupt (SWTRIG), offset 0xF00

Note: Only privileged software can enable unprivileged access to the **SWTRIG** register.

Writing an interrupt number to the **SWTRIG** register generates a Software Generated Interrupt (SGI). See Table 2-9 on page 122 for interrupt assignments.

When the **MAINPEND** bit in the **Configuration and Control (CFGCTRL)** register (see page 182) is set, unprivileged software can access the **SWTRIG** register.

Software Trigger Interrupt (SWTRIG)

Base 0xE000.E000

Offset 0xF00

Type WO, reset 0x0000.0000

	31	30	29	28	27	26	25	24	23	22	21	20	19	18	17	16
	reserved															
Type	RO	RO	RO	RO	RO	RO	RO	RO	RO	RO	RO	RO	RO	RO	RO	RO
Reset	0	0	0	0	0	0	0	0	0	0	0	0	0	0	0	0
	15	14	13	12	11	10	9	8	7	6	5	4	3	2	1	0
	reserved								INTID							
Type	RO	RO	RO	RO	RO	RO	RO	RO	WO	WO	WO	WO	WO	WO	WO	WO
Reset	0	0	0	0	0	0	0	0	0	0	0	0	0	0	0	0

Bit/Field	Name	Type	Reset	Description
31:8	reserved	RO	0x0000.00	Software should not rely on the value of a reserved bit. To provide compatibility with future products, the value of a reserved bit should be preserved across a read-modify-write operation.
7:0	INTID	WO	0x00	Interrupt ID This field holds the interrupt ID of the required SGI. For example, a value of 0x3 generates an interrupt on IRQ3.

3.5 System Control Block (SCB) Register Descriptions

This section lists and describes the System Control Block (SCB) registers, in numerical order by address offset. The SCB registers can only be accessed from privileged mode.

All registers must be accessed with aligned word accesses except for the **FAULTSTAT** and **SYSPRI1-SYSPRI3** registers, which can be accessed with byte or aligned halfword or word accesses. The processor does not support unaligned accesses to system control block registers.

Register 54: Auxiliary Control (ACTLR), offset 0x008

Note: This register can only be accessed from privileged mode.

The **ACTLR** register provides disable bits for **IT** folding, write buffer use for accesses to the default memory map, and interruption of multi-cycle instructions. By default, this register is set to provide optimum performance from the Cortex-M4 processor and does not normally require modification.

Auxiliary Control (ACTLR)

Base 0xE000.E000

Offset 0x008

Type RW, reset 0x0000.0000

	31	30	29	28	27	26	25	24	23	22	21	20	19	18	17	16
	reserved															
Type	RO	RO	RO	RO	RO	RO	RO	RO	RO	RO	RO	RO	RO	RO	RO	RO
Reset	0	0	0	0	0	0	0	0	0	0	0	0	0	0	0	0
	15	14	13	12	11	10	9	8	7	6	5	4	3	2	1	0
	reserved						DISOOF	DISFPCA	reserved					DISFOLD	DISWBUF	DISMCYC
Type	RO	RO	RO	RO	RO	RO	RW	RW	RO	RO	RO	RO	RO	RW	RW	RW
Reset	0	0	0	0	0	0	0	0	0	0	0	0	0	0	0	0

Bit/Field	Name	Type	Reset	Description
31:10	reserved	RO	0x00	Software should not rely on the value of a reserved bit. To provide compatibility with future products, the value of a reserved bit should be preserved across a read-modify-write operation.
9	DISOFP	RW	0	Disable Out-Of-Order Floating Point Disables floating-point instructions completing out of order with respect to integer instructions.
8	DISFPCA	RW	0	Disable CONTROL.FPCA Disable automatic update of the FPCA bit in the CONTROL register.
<p>Important: Two bits control when FPCA can be enabled: the ASPEN bit in the Floating-Point Context Control (FPCC) register and the DISFPCA bit in the Auxiliary Control (ACTLR) register.</p>				
7:3	reserved	RO	0x00	Software should not rely on the value of a reserved bit. To provide compatibility with future products, the value of a reserved bit should be preserved across a read-modify-write operation.
2	DISFOLD	RW	0	Disable IT Folding
	Value	Description		
	0	No effect.		
	1	Disables IT folding.		

In some situations, the processor can start executing the first instruction in an **IT** block while it is still executing the **IT** instruction. This behavior is called *IT folding*, and improves performance. However, **IT** folding can cause jitter in looping. If a task must avoid jitter, set the **DISFOLD** bit before executing the task, to disable **IT** folding.

Bit/Field	Name	Type	Reset	Description
1	DISWBUF	RW	0	Disable Write Buffer Value Description 0 No effect. 1 Disables write buffer use during default memory map accesses. In this situation, all bus faults are precise bus faults but performance is decreased because any store to memory must complete before the processor can execute the next instruction. Note: This bit only affects write buffers implemented in the Cortex-M4 processor.
0	DISMCYC	RW	0	Disable Interrupts of Multiple Cycle Instructions Value Description 0 No effect. 1 Disables interruption of load multiple and store multiple instructions. In this situation, the interrupt latency of the processor is increased because any LDM or STM must complete before the processor can stack the current state and enter the interrupt handler.

Register 55: CPU ID Base (CPUID), offset 0xD00

Note: This register can only be accessed from privileged mode.

The **CPUID** register contains the ARM® Cortex™-M4 processor part number, version, and implementation information.

CPU ID Base (CPUID)

Base 0xE000.E000

Offset 0xD00

Type RO, reset 0x410F.C241

	31	30	29	28	27	26	25	24	23	22	21	20	19	18	17	16
	IMP								VAR				CON			
Type	RO	RO	RO	RO	RO	RO	RO	RO	RO	RO	RO	RO	RO	RO	RO	RO
Reset	0	1	0	0	0	0	0	1	0	0	0	0	1	1	1	1
	15	14	13	12	11	10	9	8	7	6	5	4	3	2	1	0
	PARTNO												REV			
Type	RO	RO	RO	RO	RO	RO	RO	RO	RO	RO	RO	RO	RO	RO	RO	RO
Reset	1	1	0	0	0	0	1	0	0	1	0	0	0	0	0	1

Bit/Field	Name	Type	Reset	Description
31:24	IMP	RO	0x41	Implementer Code Value Description 0x41 ARM
23:20	VAR	RO	0x0	Variant Number Value Description 0x0 The rn value in the mpn product revision identifier, for example, the 0 in r0p0.
19:16	CON	RO	0xF	Constant Value Description 0xF Always reads as 0xF.
15:4	PARTNO	RO	0xC24	Part Number Value Description 0xC24 Cortex-M4 processor.
3:0	REV	RO	0x1	Revision Number Value Description 0x1 The pn value in the mpn product revision identifier, for example, the 1 in r0p1.

Register 56: Interrupt Control and State (INTCTRL), offset 0xD04

Note: This register can only be accessed from privileged mode.

The **INCTRL** register provides a set-pending bit for the NMI exception, and set-pending and clear-pending bits for the PendSV and SysTick exceptions. In addition, bits in this register indicate the exception number of the exception being processed, whether there are preempted active exceptions, the exception number of the highest priority pending exception, and whether any interrupts are pending.

When writing to **INCTRL**, the effect is unpredictable when writing a 1 to both the **PENDSV** and **UNPENDSV** bits, or writing a 1 to both the **PENDSTSET** and **PENDSTCLR** bits.

Interrupt Control and State (INTCTRL)

Base 0xE000.E000

Offset 0xD04

Type RW, reset 0x0000.0000

	31	30	29	28	27	26	25	24	23	22	21	20	19	18	17	16
	NMISSET	reserved		PENDSV	UNPENDSV	PENDSTSET	PENDSTCLR	reserved	ISRPRE	ISRPEND	reserved		VECPEND			
Type	RW	RO	RO	RW	WO	RW	WO	RO	RO	RO	RO	RO	RO	RO	RO	RO
Reset	0	0	0	0	0	0	0	0	0	0	0	0	0	0	0	0
	15	14	13	12	11	10	9	8	7	6	5	4	3	2	1	0
	VECPEND				RETBASE	reserved			VECACT							
Type	RO	RO	RO	RO	RO	RO	RO	RO	RO	RO	RO	RO	RO	RO	RO	RO
Reset	0	0	0	0	0	0	0	0	0	0	0	0	0	0	0	0

Bit/Field	Name	Type	Reset	Description
-----------	------	------	-------	-------------

31	NMISSET	RW	0	NMI Set Pending
----	---------	----	---	-----------------

Value Description

0	On a read, indicates an NMI exception is not pending. On a write, no effect.
---	---

1	On a read, indicates an NMI exception is pending. On a write, changes the NMI exception state to pending.
---	--

Because NMI is the highest-priority exception, normally the processor enters the NMI exception handler as soon as it registers the setting of this bit, and clears this bit on entering the interrupt handler. A read of this bit by the NMI exception handler returns 1 only if the **NMI** signal is reasserted while the processor is executing that handler.

30:29	reserved	RO	0x0	Software should not rely on the value of a reserved bit. To provide compatibility with future products, the value of a reserved bit should be preserved across a read-modify-write operation.
-------	----------	----	-----	---

28	PENDSV	RW	0	PendSV Set Pending
----	--------	----	---	--------------------

Value Description

0	On a read, indicates a PendSV exception is not pending. On a write, no effect.
---	---

1	On a read, indicates a PendSV exception is pending. On a write, changes the PendSV exception state to pending.
---	---

Setting this bit is the only way to set the PendSV exception state to pending. This bit is cleared by writing a 1 to the **UNPENDSV** bit.

Bit/Field	Name	Type	Reset	Description
27	UNPENDSV	WO	0	<p>PendSV Clear Pending</p> <p>Value Description</p> <p>0 On a write, no effect.</p> <p>1 On a write, removes the pending state from the PendSV exception.</p> <p>This bit is write only; on a register read, its value is unknown.</p>
26	PENDSTSET	RW	0	<p>SysTick Set Pending</p> <p>Value Description</p> <p>0 On a read, indicates a SysTick exception is not pending. On a write, no effect.</p> <p>1 On a read, indicates a SysTick exception is pending. On a write, changes the SysTick exception state to pending.</p> <p>This bit is cleared by writing a 1 to the PENDSTCLR bit.</p>
25	PENDSTCLR	WO	0	<p>SysTick Clear Pending</p> <p>Value Description</p> <p>0 On a write, no effect.</p> <p>1 On a write, removes the pending state from the SysTick exception.</p> <p>This bit is write only; on a register read, its value is unknown.</p>
24	reserved	RO	0	Software should not rely on the value of a reserved bit. To provide compatibility with future products, the value of a reserved bit should be preserved across a read-modify-write operation.
23	ISRPRE	RO	0	<p>Debug Interrupt Handling</p> <p>Value Description</p> <p>0 The release from halt does not take an interrupt.</p> <p>1 The release from halt takes an interrupt.</p> <p>This bit is only meaningful in Debug mode and reads as zero when the processor is not in Debug mode.</p>
22	ISRPEND	RO	0	<p>Interrupt Pending</p> <p>Value Description</p> <p>0 No interrupt is pending.</p> <p>1 An interrupt is pending.</p> <p>This bit provides status for all interrupts excluding NMI and Faults.</p>
21:20	reserved	RO	0x0	Software should not rely on the value of a reserved bit. To provide compatibility with future products, the value of a reserved bit should be preserved across a read-modify-write operation.

Bit/Field	Name	Type	Reset	Description																																				
19:12	VECPEND	RO	0x00	<p>Interrupt Pending Vector Number</p> <p>This field contains the exception number of the highest priority pending enabled exception. The value indicated by this field includes the effect of the BASEPRI and FAULTMASK registers, but not any effect of the PRIMASK register.</p> <table border="1"> <thead> <tr> <th>Value</th> <th>Description</th> </tr> </thead> <tbody> <tr><td>0x00</td><td>No exceptions are pending</td></tr> <tr><td>0x01</td><td>Reserved</td></tr> <tr><td>0x02</td><td>NMI</td></tr> <tr><td>0x03</td><td>Hard fault</td></tr> <tr><td>0x04</td><td>Memory management fault</td></tr> <tr><td>0x05</td><td>Bus fault</td></tr> <tr><td>0x06</td><td>Usage fault</td></tr> <tr><td>0x07-0x0A</td><td>Reserved</td></tr> <tr><td>0x0B</td><td>SVCall</td></tr> <tr><td>0x0C</td><td>Reserved for Debug</td></tr> <tr><td>0x0D</td><td>Reserved</td></tr> <tr><td>0x0E</td><td>PendSV</td></tr> <tr><td>0x0F</td><td>SysTick</td></tr> <tr><td>0x10</td><td>Interrupt Vector 0</td></tr> <tr><td>0x11</td><td>Interrupt Vector 1</td></tr> <tr><td>...</td><td>...</td></tr> <tr><td>0xD9</td><td>Interrupt Vector 199</td></tr> </tbody> </table>	Value	Description	0x00	No exceptions are pending	0x01	Reserved	0x02	NMI	0x03	Hard fault	0x04	Memory management fault	0x05	Bus fault	0x06	Usage fault	0x07-0x0A	Reserved	0x0B	SVCall	0x0C	Reserved for Debug	0x0D	Reserved	0x0E	PendSV	0x0F	SysTick	0x10	Interrupt Vector 0	0x11	Interrupt Vector 1	0xD9	Interrupt Vector 199
Value	Description																																							
0x00	No exceptions are pending																																							
0x01	Reserved																																							
0x02	NMI																																							
0x03	Hard fault																																							
0x04	Memory management fault																																							
0x05	Bus fault																																							
0x06	Usage fault																																							
0x07-0x0A	Reserved																																							
0x0B	SVCall																																							
0x0C	Reserved for Debug																																							
0x0D	Reserved																																							
0x0E	PendSV																																							
0x0F	SysTick																																							
0x10	Interrupt Vector 0																																							
0x11	Interrupt Vector 1																																							
...	...																																							
0xD9	Interrupt Vector 199																																							
11	RETBASE	RO	0	<p>Return to Base</p> <table border="1"> <thead> <tr> <th>Value</th> <th>Description</th> </tr> </thead> <tbody> <tr><td>0</td><td>There are preempted active exceptions to execute.</td></tr> <tr><td>1</td><td>There are no active exceptions, or the currently executing exception is the only active exception.</td></tr> </tbody> </table> <p>This bit provides status for all interrupts excluding NMI and Faults. This bit only has meaning if the processor is currently executing an ISR (the Interrupt Program Status (IPSR) register is non-zero).</p>	Value	Description	0	There are preempted active exceptions to execute.	1	There are no active exceptions, or the currently executing exception is the only active exception.																														
Value	Description																																							
0	There are preempted active exceptions to execute.																																							
1	There are no active exceptions, or the currently executing exception is the only active exception.																																							
10:8	reserved	RO	0x0	Software should not rely on the value of a reserved bit. To provide compatibility with future products, the value of a reserved bit should be preserved across a read-modify-write operation.																																				
7:0	VECACT	RO	0x00	<p>Interrupt Pending Vector Number</p> <p>This field contains the active exception number. The exception numbers can be found in the description for the VECPEND field. If this field is clear, the processor is in Thread mode. This field contains the same value as the ISRNUM field in the IPSR register.</p> <p>Subtract 16 from this value to obtain the IRQ number required to index into the Interrupt Set Enable (ENn), Interrupt Clear Enable (DISn), Interrupt Set Pending (PENDn), Interrupt Clear Pending (UNPENDn), and Interrupt Priority (PRIn) registers (see page 98).</p>																																				

Register 57: Vector Table Offset (VTABLE), offset 0xD08

Note: This register can only be accessed from privileged mode.

The **VTABLE** register indicates the offset of the vector table base address from memory address 0x0000.0000.

Vector Table Offset (VTABLE)

Base 0xE000.E000

Offset 0xD08

Type RW, reset 0x0000.0000

	31	30	29	28	27	26	25	24	23	22	21	20	19	18	17	16
	OFFSET															
Type	RW	RW	RW	RW	RW	RW	RW	RW	RW	RW	RW	RW	RW	RW	RW	RW
Reset	0	0	0	0	0	0	0	0	0	0	0	0	0	0	0	0
	15	14	13	12	11	10	9	8	7	6	5	4	3	2	1	0
	OFFSET						reserved									
Type	RW	RW	RW	RW	RW	RW	RO	RO	RO	RO	RO	RO	RO	RO	RO	RO
Reset	0	0	0	0	0	0	0	0	0	0	0	0	0	0	0	0

Bit/Field	Name	Type	Reset	Description
31:10	OFFSET	RW	0x000.00	Vector Table Offset When configuring the <code>OFFSET</code> field, the offset must be aligned to the number of exception entries in the vector table. Because there are 112 interrupts, the offset must be aligned on a 1024-byte boundary.
9:0	reserved	RO	0x00	Software should not rely on the value of a reserved bit. To provide compatibility with future products, the value of a reserved bit should be preserved across a read-modify-write operation.

Register 58: Application Interrupt and Reset Control (APINT), offset 0xD0C

Note: This register can only be accessed from privileged mode.

The **APINT** register provides priority grouping control for the exception model, endian status for data accesses, and reset control of the system. To write to this register, 0x05FA must be written to the **VECTKEY** field, otherwise the write is ignored.

The **PRIGROUP** field indicates the position of the binary point that splits the **INTx** fields in the **Interrupt Priority (PRIx)** registers into separate group priority and subpriority fields. Table 3-9 on page 178 shows how the **PRIGROUP** value controls this split. The bit numbers in the Group Priority Field and Subpriority Field columns in the table refer to the bits in the **INTA** field. For the **INTB** field, the corresponding bits are 15:13; for **INTC**, 23:21; and for **INTD**, 31:29.

Note: Determining preemption of an exception uses only the group priority field.

Table 3-9. Interrupt Priority Levels

PRIGROUP Bit Field	Binary Point ^a	Group Priority Field	Subpriority Field	Group Priorities	Subpriorities
0x0 - 0x4	bxxx.	[7:5]	None	8	1
0x5	bxx.y	[7:6]	[5]	4	2
0x6	bx.yy	[7]	[6:5]	2	4
0x7	b.yyy	None	[7:5]	1	8

a. **INTx** field showing the binary point. An x denotes a group priority field bit, and a y denotes a subpriority field bit.

Application Interrupt and Reset Control (APINT)

Base 0xE000.E000

Offset 0xD0C

Type RW, reset 0xFA05.0000

	31	30	29	28	27	26	25	24	23	22	21	20	19	18	17	16
	VECTKEY															
Type	RW	RW	RW	RW	RW	RW	RW	RW	RW	RW	RW	RW	RW	RW	RW	RW
Reset	1	1	1	1	1	0	1	0	0	0	0	0	0	1	0	1
	15	14	13	12	11	10	9	8	7	6	5	4	3	2	1	0
	ENDIANESS	reserved				PRIGROUP				reserved				SYSRESREQ	VECTLRRACT	VECTRESET
Type	RO	RO	RO	RO	RO	RW	RW	RW	RO	RO	RO	RO	RO	RO	WO	WO
Reset	0	0	0	0	0	0	0	0	0	0	0	0	0	0	0	0

Bit/Field	Name	Type	Reset	Description
31:16	VECTKEY	RW	0xFA05	Register Key This field is used to guard against accidental writes to this register. 0x05FA must be written to this field in order to change the bits in this register. On a read, 0xFA05 is returned.
15	ENDIANESS	RO	0	Data Endianess The Tiva™ C Series implementation uses only little-endian mode so this is cleared to 0.
14:11	reserved	RO	0x0	Software should not rely on the value of a reserved bit. To provide compatibility with future products, the value of a reserved bit should be preserved across a read-modify-write operation.

Bit/Field	Name	Type	Reset	Description
10:8	PRIGROUP	RW	0x0	Interrupt Priority Grouping This field determines the split of group priority from subpriority (see Table 3-9 on page 178 for more information).
7:3	reserved	RO	0x0	Software should not rely on the value of a reserved bit. To provide compatibility with future products, the value of a reserved bit should be preserved across a read-modify-write operation.
2	SYSRESREQ	WO	0	System Reset Request Value Description 0 No effect. 1 Resets the core and all on-chip peripherals except the Debug interface. This bit is automatically cleared during the reset of the core and reads as 0.
1	VECTCLRACT	WO	0	Clear Active NMI / Fault This bit is reserved for Debug use and reads as 0. This bit must be written as a 0, otherwise behavior is unpredictable.
0	VECTRESET	WO	0	System Reset This bit is reserved for Debug use and reads as 0. This bit must be written as a 0, otherwise behavior is unpredictable.

Register 59: System Control (SYSCTRL), offset 0xD10**Note:** This register can only be accessed from privileged mode.The **SYSCTRL** register controls features of entry to and exit from low-power state.

System Control (SYSCTRL)

Base 0xE000.E000

Offset 0xD10

Type RW, reset 0x0000.0000

	31	30	29	28	27	26	25	24	23	22	21	20	19	18	17	16	
	reserved																
Type	RO	RO	RO	RO	RO	RO	RO	RO	RO	RO	RO	RO	RO	RO	RO	RO	
Reset	0	0	0	0	0	0	0	0	0	0	0	0	0	0	0	0	
	15	14	13	12	11	10	9	8	7	6	5	4	3	2	1	0	
	reserved												SEVONPEND	reserved	SLEEPDEEP	SLEEPEXIT	reserved
Type	RO	RO	RO	RO	RO	RO	RO	RO	RO	RO	RO	RO	RW	RO	RW	RW	RO
Reset	0	0	0	0	0	0	0	0	0	0	0	0	0	0	0	0	0

Bit/Field	Name	Type	Reset	Description
31:5	reserved	RO	0x0000.00	Software should not rely on the value of a reserved bit. To provide compatibility with future products, the value of a reserved bit should be preserved across a read-modify-write operation.
4	SEVONPEND	RW	0	<p>Wake Up on Pending</p> <p>Value Description</p> <p>0 Only enabled interrupts or events can wake up the processor; disabled interrupts are excluded.</p> <p>1 Enabled events and all interrupts, including disabled interrupts, can wake up the processor.</p> <p>When an event or interrupt enters the pending state, the event signal wakes up the processor from <i>WFE</i>. If the processor is not waiting for an event, the event is registered and affects the next <i>WFE</i>. The processor also wakes up on execution of a <i>SEV</i> instruction or an external event.</p>
3	reserved	RO	0	Software should not rely on the value of a reserved bit. To provide compatibility with future products, the value of a reserved bit should be preserved across a read-modify-write operation.
2	SLEEPDEEP	RW	0	<p>Deep Sleep Enable</p> <p>Value Description</p> <p>0 Use Sleep mode as the low power mode.</p> <p>1 Use Deep-sleep mode as the low power mode.</p>

Bit/Field	Name	Type	Reset	Description
1	SLEEPEXIT	RW	0	<p>Sleep on ISR Exit</p> <p>Value Description</p> <p>0 When returning from Handler mode to Thread mode, do not sleep when returning to Thread mode.</p> <p>1 When returning from Handler mode to Thread mode, enter sleep or deep sleep on return from an ISR.</p> <p>Setting this bit enables an interrupt-driven application to avoid returning to an empty main application.</p>
0	reserved	RO	0	<p>Software should not rely on the value of a reserved bit. To provide compatibility with future products, the value of a reserved bit should be preserved across a read-modify-write operation.</p>

Register 60: Configuration and Control (CFGCTRL), offset 0xD14

Note: This register can only be accessed from privileged mode.

The **CFGCTRL** register controls entry to Thread mode and enables: the handlers for NMI, hard fault and faults escalated by the **FAULTMASK** register to ignore bus faults; trapping of divide by zero and unaligned accesses; and access to the **SWTRIG** register by unprivileged software (see page 170).

Configuration and Control (CFGCTRL)

Base 0xE000.E000

Offset 0xD14

Type RW, reset 0x0000.0200

	31	30	29	28	27	26	25	24	23	22	21	20	19	18	17	16	
	reserved																
Type	RO	RO	RO	RO	RO	RO	RO	RO	RO	RO	RO	RO	RO	RO	RO	RO	
Reset	0	0	0	0	0	0	0	0	0	0	0	0	0	0	0	0	
	15	14	13	12	11	10	9	8	7	6	5	4	3	2	1	0	
	reserved						STKALIGN	BHFHNMIGN	reserved				DIV0	UNALIGNED	reserved	MAINPEND	BASETHR
Type	RO	RO	RO	RO	RO	RO	RW	RW	RO	RO	RO	RW	RW	RO	RW	RW	
Reset	0	0	0	0	0	0	1	0	0	0	0	0	0	0	0	0	

Bit/Field	Name	Type	Reset	Description
31:10	reserved	RO	0x0000.00	Software should not rely on the value of a reserved bit. To provide compatibility with future products, the value of a reserved bit should be preserved across a read-modify-write operation.
9	STKALIGN	RW	1	Stack Alignment on Exception Entry Value Description 0 The stack is 4-byte aligned. 1 The stack is 8-byte aligned. On exception entry, the processor uses bit 9 of the stacked PSR to indicate the stack alignment. On return from the exception, it uses this stacked bit to restore the correct stack alignment.
8	BHFHNMIGN	RW	0	Ignore Bus Fault in NMI and Fault This bit enables handlers with priority -1 or -2 to ignore data bus faults caused by load and store instructions. The setting of this bit applies to the hard fault, NMI, and FAULTMASK escalated handlers. Value Description 0 Data bus faults caused by load and store instructions cause a lock-up. 1 Handlers running at priority -1 and -2 ignore data bus faults caused by load and store instructions. Set this bit only when the handler and its data are in absolutely safe memory. The normal use of this bit is to probe system devices and bridges to detect control path problems and fix them.
7:5	reserved	RO	0x0	Software should not rely on the value of a reserved bit. To provide compatibility with future products, the value of a reserved bit should be preserved across a read-modify-write operation.

Bit/Field	Name	Type	Reset	Description
4	DIV0	RW	0	<p>Trap on Divide by 0</p> <p>This bit enables faulting or halting when the processor executes an <code>SDIV</code> or <code>UDIV</code> instruction with a divisor of 0.</p> <p>Value Description</p> <p>0 Do not trap on divide by 0. A divide by zero returns a quotient of 0.</p> <p>1 Trap on divide by 0.</p>
3	UNALIGNED	RW	0	<p>Trap on Unaligned Access</p> <p>Value Description</p> <p>0 Do not trap on unaligned halfword and word accesses.</p> <p>1 Trap on unaligned halfword and word accesses. An unaligned access generates a usage fault.</p> <p>Unaligned <code>LDM</code>, <code>STM</code>, <code>LDRD</code>, and <code>STRD</code> instructions always fault regardless of whether <code>UNALIGNED</code> is set.</p>
2	reserved	RO	0	Software should not rely on the value of a reserved bit. To provide compatibility with future products, the value of a reserved bit should be preserved across a read-modify-write operation.
1	MAINPEND	RW	0	<p>Allow Main Interrupt Trigger</p> <p>Value Description</p> <p>0 Disables unprivileged software access to the SWTRIG register.</p> <p>1 Enables unprivileged software access to the SWTRIG register (see page 170).</p>
0	BASETHR	RW	0	<p>Thread State Control</p> <p>Value Description</p> <p>0 The processor can enter Thread mode only when no exception is active.</p> <p>1 The processor can enter Thread mode from any level under the control of an <code>EXC_RETURN</code> value (see "Exception Return" on page 129 for more information).</p>

Register 61: System Handler Priority 1 (SYSPRI1), offset 0xD18

Note: This register can only be accessed from privileged mode.

The **SYSPRI1** register configures the priority level, 0 to 7 of the usage fault, bus fault, and memory management fault exception handlers. This register is byte-accessible.

System Handler Priority 1 (SYSPRI1)

Base 0xE000.E000

Offset 0xD18

Type RW, reset 0x0000.0000

	31	30	29	28	27	26	25	24	23	22	21	20	19	18	17	16
	reserved								USAGE			reserved				
Type	RO	RO	RO	RO	RO	RO	RO	RO	RW	RW	RW	RO	RO	RO	RO	RO
Reset	0	0	0	0	0	0	0	0	0	0	0	0	0	0	0	0
	15	14	13	12	11	10	9	8	7	6	5	4	3	2	1	0
	BUS			reserved					MEM			reserved				
Type	RW	RW	RW	RO	RO	RO	RO	RO	RW	RW	RW	RO	RO	RO	RO	RO
Reset	0	0	0	0	0	0	0	0	0	0	0	0	0	0	0	0

Bit/Field	Name	Type	Reset	Description
31:24	reserved	RO	0x00	Software should not rely on the value of a reserved bit. To provide compatibility with future products, the value of a reserved bit should be preserved across a read-modify-write operation.
23:21	USAGE	RW	0x0	Usage Fault Priority This field configures the priority level of the usage fault. Configurable priority values are in the range 0-7, with lower values having higher priority.
20:16	reserved	RO	0x0	Software should not rely on the value of a reserved bit. To provide compatibility with future products, the value of a reserved bit should be preserved across a read-modify-write operation.
15:13	BUS	RW	0x0	Bus Fault Priority This field configures the priority level of the bus fault. Configurable priority values are in the range 0-7, with lower values having higher priority.
12:8	reserved	RO	0x0	Software should not rely on the value of a reserved bit. To provide compatibility with future products, the value of a reserved bit should be preserved across a read-modify-write operation.
7:5	MEM	RW	0x0	Memory Management Fault Priority This field configures the priority level of the memory management fault. Configurable priority values are in the range 0-7, with lower values having higher priority.
4:0	reserved	RO	0x0	Software should not rely on the value of a reserved bit. To provide compatibility with future products, the value of a reserved bit should be preserved across a read-modify-write operation.

Register 62: System Handler Priority 2 (SYSPRI2), offset 0xD1C

Note: This register can only be accessed from privileged mode.

The **SYSPRI2** register configures the priority level, 0 to 7 of the SVCcall handler. This register is byte-accessible.

System Handler Priority 2 (SYSPRI2)

Base 0xE000.E000

Offset 0xD1C

Type RW, reset 0x0000.0000

	31	30	29	28	27	26	25	24	23	22	21	20	19	18	17	16
	SVC			reserved												
Type	RW	RW	RW	RO	RO	RO	RO	RO	RO	RO	RO	RO	RO	RO	RO	RO
Reset	0	0	0	0	0	0	0	0	0	0	0	0	0	0	0	0
	15	14	13	12	11	10	9	8	7	6	5	4	3	2	1	0
	reserved															
Type	RO	RO	RO	RO	RO	RO	RO	RO	RO	RO	RO	RO	RO	RO	RO	RO
Reset	0	0	0	0	0	0	0	0	0	0	0	0	0	0	0	0

Bit/Field	Name	Type	Reset	Description
31:29	SVC	RW	0x0	SVCcall Priority This field configures the priority level of SVCcall. Configurable priority values are in the range 0-7, with lower values having higher priority.
28:0	reserved	RO	0x000.0000	Software should not rely on the value of a reserved bit. To provide compatibility with future products, the value of a reserved bit should be preserved across a read-modify-write operation.

Register 63: System Handler Priority 3 (SYSPRI3), offset 0xD20

Note: This register can only be accessed from privileged mode.

The **SYSPRI3** register configures the priority level, 0 to 7 of the SysTick exception and PendSV handlers. This register is byte-accessible.

System Handler Priority 3 (SYSPRI3)

Base 0xE000.E000

Offset 0xD20

Type RW, reset 0x0000.0000

	31	30	29	28	27	26	25	24	23	22	21	20	19	18	17	16
	TICK			reserved					PENDSV			reserved				
Type	RW	RW	RW	RO	RO	RO	RO	RO	RW	RW	RW	RO	RO	RO	RO	RO
Reset	0	0	0	0	0	0	0	0	0	0	0	0	0	0	0	0
	15	14	13	12	11	10	9	8	7	6	5	4	3	2	1	0
	reserved								DEBUG			reserved				
Type	RO	RO	RO	RO	RO	RO	RO	RO	RW	RW	RW	RO	RO	RO	RO	RO
Reset	0	0	0	0	0	0	0	0	0	0	0	0	0	0	0	0

Bit/Field	Name	Type	Reset	Description
31:29	TICK	RW	0x0	SysTick Exception Priority This field configures the priority level of the SysTick exception. Configurable priority values are in the range 0-7, with lower values having higher priority.
28:24	reserved	RO	0x0	Software should not rely on the value of a reserved bit. To provide compatibility with future products, the value of a reserved bit should be preserved across a read-modify-write operation.
23:21	PENDSV	RW	0x0	PendSV Priority This field configures the priority level of PendSV. Configurable priority values are in the range 0-7, with lower values having higher priority.
20:8	reserved	RO	0x000	Software should not rely on the value of a reserved bit. To provide compatibility with future products, the value of a reserved bit should be preserved across a read-modify-write operation.
7:5	DEBUG	RW	0x0	Debug Priority This field configures the priority level of Debug. Configurable priority values are in the range 0-7, with lower values having higher priority.
4:0	reserved	RO	0x0.0000	Software should not rely on the value of a reserved bit. To provide compatibility with future products, the value of a reserved bit should be preserved across a read-modify-write operation.

Register 64: System Handler Control and State (SYSHNDCTRL), offset 0xD24

Note: This register can only be accessed from privileged mode.

The **SYSHNDCTRL** register enables the system handlers, and indicates the pending status of the usage fault, bus fault, memory management fault, and SVC exceptions as well as the active status of the system handlers.

If a system handler is disabled and the corresponding fault occurs, the processor treats the fault as a hard fault.

This register can be modified to change the pending or active status of system exceptions. An OS kernel can write to the active bits to perform a context switch that changes the current exception type.

Caution – Software that changes the value of an active bit in this register without correct adjustment to the stacked content can cause the processor to generate a fault exception. Ensure software that writes to this register retains and subsequently restores the current active status.

If the value of a bit in this register must be modified after enabling the system handlers, a read-modify-write procedure must be used to ensure that only the required bit is modified.

System Handler Control and State (SYSHNDCTRL)

Base 0xE000.E000

Offset 0xD24

Type RW, reset 0x0000.0000

	31	30	29	28	27	26	25	24	23	22	21	20	19	18	17	16
	reserved													USAGE	BUS	MEM
Type	RO	RO	RO	RO	RO	RO	RO	RO	RO	RO	RO	RO	RO	RW	RW	RW
Reset	0	0	0	0	0	0	0	0	0	0	0	0	0	0	0	0
	15	14	13	12	11	10	9	8	7	6	5	4	3	2	1	0
	SVC	BUSP	MEMP	USAGEP	TICK	PNDSV	reserved	MON	SVCA	reserved			USGA	reserved	BUSA	MEMA
Type	RW	RW	RW	RW	RW	RW	RO	RW	RW	RO	RO	RO	RW	RO	RW	RW
Reset	0	0	0	0	0	0	0	0	0	0	0	0	0	0	0	0

Bit/Field	Name	Type	Reset	Description
31:19	reserved	RO	0x000	Software should not rely on the value of a reserved bit. To provide compatibility with future products, the value of a reserved bit should be preserved across a read-modify-write operation.
18	USAGE	RW	0	Usage Fault Enable Value Description 0 Disables the usage fault exception. 1 Enables the usage fault exception.
17	BUS	RW	0	Bus Fault Enable Value Description 0 Disables the bus fault exception. 1 Enables the bus fault exception.

Bit/Field	Name	Type	Reset	Description
16	MEM	RW	0	<p>Memory Management Fault Enable</p> <p>Value Description</p> <p>0 Disables the memory management fault exception.</p> <p>1 Enables the memory management fault exception.</p>
15	SVC	RW	0	<p>SVC Call Pending</p> <p>Value Description</p> <p>0 An SVC call exception is not pending.</p> <p>1 An SVC call exception is pending.</p> <p>This bit can be modified to change the pending status of the SVC call exception.</p>
14	BUSP	RW	0	<p>Bus Fault Pending</p> <p>Value Description</p> <p>0 A bus fault exception is not pending.</p> <p>1 A bus fault exception is pending.</p> <p>This bit can be modified to change the pending status of the bus fault exception.</p>
13	MEMP	RW	0	<p>Memory Management Fault Pending</p> <p>Value Description</p> <p>0 A memory management fault exception is not pending.</p> <p>1 A memory management fault exception is pending.</p> <p>This bit can be modified to change the pending status of the memory management fault exception.</p>
12	USAGEP	RW	0	<p>Usage Fault Pending</p> <p>Value Description</p> <p>0 A usage fault exception is not pending.</p> <p>1 A usage fault exception is pending.</p> <p>This bit can be modified to change the pending status of the usage fault exception.</p>
11	TICK	RW	0	<p>SysTick Exception Active</p> <p>Value Description</p> <p>0 A SysTick exception is not active.</p> <p>1 A SysTick exception is active.</p> <p>This bit can be modified to change the active status of the SysTick exception, however, see the Caution above before setting this bit.</p>

Bit/Field	Name	Type	Reset	Description
10	PNSV	RW	0	<p>PendSV Exception Active</p> <p>Value Description</p> <p>0 A PendSV exception is not active.</p> <p>1 A PendSV exception is active.</p> <p>This bit can be modified to change the active status of the PendSV exception, however, see the Caution above before setting this bit.</p>
9	reserved	RO	0	Software should not rely on the value of a reserved bit. To provide compatibility with future products, the value of a reserved bit should be preserved across a read-modify-write operation.
8	MON	RW	0	<p>Debug Monitor Active</p> <p>Value Description</p> <p>0 The Debug monitor is not active.</p> <p>1 The Debug monitor is active.</p>
7	SVCA	RW	0	<p>SVC Call Active</p> <p>Value Description</p> <p>0 SVC call is not active.</p> <p>1 SVC call is active.</p> <p>This bit can be modified to change the active status of the SVC call exception, however, see the Caution above before setting this bit.</p>
6:4	reserved	RO	0x0	Software should not rely on the value of a reserved bit. To provide compatibility with future products, the value of a reserved bit should be preserved across a read-modify-write operation.
3	USGA	RW	0	<p>Usage Fault Active</p> <p>Value Description</p> <p>0 Usage fault is not active.</p> <p>1 Usage fault is active.</p> <p>This bit can be modified to change the active status of the usage fault exception, however, see the Caution above before setting this bit.</p>
2	reserved	RO	0	Software should not rely on the value of a reserved bit. To provide compatibility with future products, the value of a reserved bit should be preserved across a read-modify-write operation.
1	BUSA	RW	0	<p>Bus Fault Active</p> <p>Value Description</p> <p>0 Bus fault is not active.</p> <p>1 Bus fault is active.</p> <p>This bit can be modified to change the active status of the bus fault exception, however, see the Caution above before setting this bit.</p>

Bit/Field	Name	Type	Reset	Description
0	MEMA	RW	0	Memory Management Fault Active
				Value Description
				0 Memory management fault is not active.
				1 Memory management fault is active.
				This bit can be modified to change the active status of the memory management fault exception, however, see the Caution above before setting this bit.

Register 65: Configurable Fault Status (FAULTSTAT), offset 0xD28

Note: This register can only be accessed from privileged mode.

The **FAULTSTAT** register indicates the cause of a memory management fault, bus fault, or usage fault. Each of these functions is assigned to a subregister as follows:

- **Usage Fault Status (UFAULTSTAT)**, bits 31:16
- **Bus Fault Status (BFAULTSTAT)**, bits 15:8
- **Memory Management Fault Status (MFAULTSTAT)**, bits 7:0

FAULTSTAT is byte accessible. **FAULTSTAT** or its subregisters can be accessed as follows:

- The complete **FAULTSTAT** register, with a word access to offset 0xD28
- The **MFAULTSTAT**, with a byte access to offset 0xD28
- The **MFAULTSTAT** and **BFAULTSTAT**, with a halfword access to offset 0xD28
- The **BFAULTSTAT**, with a byte access to offset 0xD29
- The **UFAULTSTAT**, with a halfword access to offset 0xD2A

Bits are cleared by writing a 1 to them.

In a fault handler, the true faulting address can be determined by:

1. Read and save the **Memory Management Fault Address (MMADDR)** or **Bus Fault Address (FAULTADDR)** value.
2. Read the **MMARV** bit in **MFAULTSTAT**, or the **BFARV** bit in **BFAULTSTAT** to determine if the **MMADDR** or **FAULTADDR** contents are valid.

Software must follow this sequence because another higher priority exception might change the **MMADDR** or **FAULTADDR** value. For example, if a higher priority handler preempts the current fault handler, the other fault might change the **MMADDR** or **FAULTADDR** value.

Configurable Fault Status (FAULTSTAT)

Base 0xE000.E000
Offset 0xD28
Type RW1C, reset 0x0000.0000

	31	30	29	28	27	26	25	24	23	22	21	20	19	18	17	16
	reserved						DIV0	UNALIGN	reserved				NOCP	INVPC	INVSTAT	UNDEF
Type	RO	RO	RO	RO	RO	RO	RW1C	RW1C	RO	RO	RO	RO	RW1C	RW1C	RW1C	RW1C
Reset	0	0	0	0	0	0	0	0	0	0	0	0	0	0	0	0
	15	14	13	12	11	10	9	8	7	6	5	4	3	2	1	0
	BFARV	reserved	BLSPERR	BSTKE	BUSTKE	IMPRE	PRECISE	IBUS	MMARV	reserved	MLSPERR	MSTKE	MUSTKE	reserved	DERR	IERR
Type	RW1C	RO	RW1C	RW1C	RW1C	RW1C	RW1C	RW1C	RW1C	RO	RW1C	RW1C	RW1C	RO	RW1C	RW1C
Reset	0	0	0	0	0	0	0	0	0	0	0	0	0	0	0	0

Bit/Field	Name	Type	Reset	Description
31:26	reserved	RO	0x00	Software should not rely on the value of a reserved bit. To provide compatibility with future products, the value of a reserved bit should be preserved across a read-modify-write operation.

Bit/Field	Name	Type	Reset	Description
25	DIV0	RW1C	0	<p>Divide-by-Zero Usage Fault</p> <p>Value Description</p> <p>0 No divide-by-zero fault has occurred, or divide-by-zero trapping is not enabled.</p> <p>1 The processor has executed an SDIV or UDIV instruction with a divisor of 0.</p> <p>When this bit is set, the PC value stacked for the exception return points to the instruction that performed the divide by zero.</p> <p>Trapping on divide-by-zero is enabled by setting the DIV0 bit in the Configuration and Control (CFGCTRL) register (see page 182).</p> <p>This bit is cleared by writing a 1 to it.</p>
24	UNALIGN	RW1C	0	<p>Unaligned Access Usage Fault</p> <p>Value Description</p> <p>0 No unaligned access fault has occurred, or unaligned access trapping is not enabled.</p> <p>1 The processor has made an unaligned memory access.</p> <p>Unaligned LDM, STM, LDRD, and STRD instructions always fault regardless of the configuration of this bit.</p> <p>Trapping on unaligned access is enabled by setting the UNALIGNED bit in the CFGCTRL register (see page 182).</p> <p>This bit is cleared by writing a 1 to it.</p>
23:20	reserved	RO	0x00	Software should not rely on the value of a reserved bit. To provide compatibility with future products, the value of a reserved bit should be preserved across a read-modify-write operation.
19	NOCP	RW1C	0	<p>No Coprocessor Usage Fault</p> <p>Value Description</p> <p>0 A usage fault has not been caused by attempting to access a coprocessor.</p> <p>1 The processor has attempted to access a coprocessor.</p> <p>This bit is cleared by writing a 1 to it.</p>
18	INVPC	RW1C	0	<p>Invalid PC Load Usage Fault</p> <p>Value Description</p> <p>0 A usage fault has not been caused by attempting to load an invalid PC value.</p> <p>1 The processor has attempted an illegal load of EXC_RETURN to the PC as a result of an invalid context or an invalid EXC_RETURN value.</p> <p>When this bit is set, the PC value stacked for the exception return points to the instruction that tried to perform the illegal load of the PC.</p> <p>This bit is cleared by writing a 1 to it.</p>

Bit/Field	Name	Type	Reset	Description
17	INVSTAT	RW1C	0	<p>Invalid State Usage Fault</p> <p>Value Description</p> <p>0 A usage fault has not been caused by an invalid state.</p> <p>1 The processor has attempted to execute an instruction that makes illegal use of the EPSR register.</p> <p>When this bit is set, the PC value stacked for the exception return points to the instruction that attempted the illegal use of the Execution Program Status Register (EPSR) register.</p> <p>This bit is not set if an undefined instruction uses the EPSR register. This bit is cleared by writing a 1 to it.</p>
16	UNDEF	RW1C	0	<p>Undefined Instruction Usage Fault</p> <p>Value Description</p> <p>0 A usage fault has not been caused by an undefined instruction.</p> <p>1 The processor has attempted to execute an undefined instruction.</p> <p>When this bit is set, the PC value stacked for the exception return points to the undefined instruction.</p> <p>An undefined instruction is an instruction that the processor cannot decode.</p> <p>This bit is cleared by writing a 1 to it.</p>
15	BFARV	RW1C	0	<p>Bus Fault Address Register Valid</p> <p>Value Description</p> <p>0 The value in the Bus Fault Address (FAULTADDR) register is not a valid fault address.</p> <p>1 The FAULTADDR register is holding a valid fault address.</p> <p>This bit is set after a bus fault, where the address is known. Other faults can clear this bit, such as a memory management fault occurring later. If a bus fault occurs and is escalated to a hard fault because of priority, the hard fault handler must clear this bit. This action prevents problems if returning to a stacked active bus fault handler whose FAULTADDR register value has been overwritten.</p> <p>This bit is cleared by writing a 1 to it.</p>
14	reserved	RO	0	<p>Software should not rely on the value of a reserved bit. To provide compatibility with future products, the value of a reserved bit should be preserved across a read-modify-write operation.</p>
13	BLSPERR	RW1C	0	<p>Bus Fault on Floating-Point Lazy State Preservation</p> <p>Value Description</p> <p>0 No bus fault has occurred during floating-point lazy state preservation.</p> <p>1 A bus fault has occurred during floating-point lazy state preservation.</p> <p>This bit is cleared by writing a 1 to it.</p>

Bit/Field	Name	Type	Reset	Description
12	BSTKE	RW1C	0	<p>Stack Bus Fault</p> <p>Value Description</p> <p>0 No bus fault has occurred on stacking for exception entry.</p> <p>1 Stacking for an exception entry has caused one or more bus faults.</p> <p>When this bit is set, the SP is still adjusted but the values in the context area on the stack might be incorrect. A fault address is not written to the FAULTADDR register.</p> <p>This bit is cleared by writing a 1 to it.</p>
11	BUSTKE	RW1C	0	<p>Unstack Bus Fault</p> <p>Value Description</p> <p>0 No bus fault has occurred on unstacking for a return from exception.</p> <p>1 Unstacking for a return from exception has caused one or more bus faults.</p> <p>This fault is chained to the handler. Thus, when this bit is set, the original return stack is still present. The SP is not adjusted from the failing return, a new save is not performed, and a fault address is not written to the FAULTADDR register.</p> <p>This bit is cleared by writing a 1 to it.</p>
10	IMPRE	RW1C	0	<p>Imprecise Data Bus Error</p> <p>Value Description</p> <p>0 An imprecise data bus error has not occurred.</p> <p>1 A data bus error has occurred, but the return address in the stack frame is not related to the instruction that caused the error.</p> <p>When this bit is set, a fault address is not written to the FAULTADDR register.</p> <p>This fault is asynchronous. Therefore, if the fault is detected when the priority of the current process is higher than the bus fault priority, the bus fault becomes pending and becomes active only when the processor returns from all higher-priority processes. If a precise fault occurs before the processor enters the handler for the imprecise bus fault, the handler detects that both the IMPRE bit is set and one of the precise fault status bits is set.</p> <p>This bit is cleared by writing a 1 to it.</p>
9	PRECISE	RW1C	0	<p>Precise Data Bus Error</p> <p>Value Description</p> <p>0 A precise data bus error has not occurred.</p> <p>1 A data bus error has occurred, and the PC value stacked for the exception return points to the instruction that caused the fault.</p> <p>When this bit is set, the fault address is written to the FAULTADDR register.</p> <p>This bit is cleared by writing a 1 to it.</p>

Bit/Field	Name	Type	Reset	Description
8	IBUS	RW1C	0	<p>Instruction Bus Error</p> <p>Value Description</p> <p>0 An instruction bus error has not occurred.</p> <p>1 An instruction bus error has occurred.</p> <p>The processor detects the instruction bus error on prefetching an instruction, but sets this bit only if it attempts to issue the faulting instruction.</p> <p>When this bit is set, a fault address is not written to the FAULTADDR register.</p> <p>This bit is cleared by writing a 1 to it.</p>
7	MMARV	RW1C	0	<p>Memory Management Fault Address Register Valid</p> <p>Value Description</p> <p>0 The value in the Memory Management Fault Address (MMADDR) register is not a valid fault address.</p> <p>1 The MMADDR register is holding a valid fault address.</p> <p>If a memory management fault occurs and is escalated to a hard fault because of priority, the hard fault handler must clear this bit. This action prevents problems if returning to a stacked active memory management fault handler whose MMADDR register value has been overwritten.</p> <p>This bit is cleared by writing a 1 to it.</p>
6	reserved	RO	0	<p>Software should not rely on the value of a reserved bit. To provide compatibility with future products, the value of a reserved bit should be preserved across a read-modify-write operation.</p>
5	MLSPERR	RW1C	0	<p>Memory Management Fault on Floating-Point Lazy State Preservation</p> <p>Value Description</p> <p>0 No memory management fault has occurred during floating-point lazy state preservation.</p> <p>1 No memory management fault has occurred during floating-point lazy state preservation.</p> <p>This bit is cleared by writing a 1 to it.</p>
4	MSTKE	RW1C	0	<p>Stack Access Violation</p> <p>Value Description</p> <p>0 No memory management fault has occurred on stacking for exception entry.</p> <p>1 Stacking for an exception entry has caused one or more access violations.</p> <p>When this bit is set, the SP is still adjusted but the values in the context area on the stack might be incorrect. A fault address is not written to the MMADDR register.</p> <p>This bit is cleared by writing a 1 to it.</p>

Bit/Field	Name	Type	Reset	Description
3	MUSTKE	RW1C	0	<p>Unstack Access Violation</p> <p>Value Description</p> <p>0 No memory management fault has occurred on unstacking for a return from exception.</p> <p>1 Unstacking for a return from exception has caused one or more access violations.</p> <p>This fault is chained to the handler. Thus, when this bit is set, the original return stack is still present. The SP is not adjusted from the failing return, a new save is not performed, and a fault address is not written to the MMADDR register.</p> <p>This bit is cleared by writing a 1 to it.</p>
2	reserved	RO	0	<p>Software should not rely on the value of a reserved bit. To provide compatibility with future products, the value of a reserved bit should be preserved across a read-modify-write operation.</p>
1	DERR	RW1C	0	<p>Data Access Violation</p> <p>Value Description</p> <p>0 A data access violation has not occurred.</p> <p>1 The processor attempted a load or store at a location that does not permit the operation.</p> <p>When this bit is set, the PC value stacked for the exception return points to the faulting instruction and the address of the attempted access is written to the MMADDR register.</p> <p>This bit is cleared by writing a 1 to it.</p>
0	IERR	RW1C	0	<p>Instruction Access Violation</p> <p>Value Description</p> <p>0 An instruction access violation has not occurred.</p> <p>1 The processor attempted an instruction fetch from a location that does not permit execution.</p> <p>This fault occurs on any access to an XN region, even when the MPU is disabled or not present.</p> <p>When this bit is set, the PC value stacked for the exception return points to the faulting instruction and the address of the attempted access is not written to the MMADDR register.</p> <p>This bit is cleared by writing a 1 to it.</p>

Register 66: Hard Fault Status (HFAULTSTAT), offset 0xD2C

Note: This register can only be accessed from privileged mode.

The **HFAULTSTAT** register gives information about events that activate the hard fault handler.

Bits are cleared by writing a 1 to them.

Hard Fault Status (HFAULTSTAT)

Base 0xE000.E000
Offset 0xD2C
Type RW1C, reset 0x0000.0000

	31	30	29	28	27	26	25	24	23	22	21	20	19	18	17	16	
	DBG	FORCED	reserved														
Type	RW1C	RW1C	RO	RO	RO	RO	RO	RO	RO	RO	RO	RO	RO	RO	RO	RO	
Reset	0	0	0	0	0	0	0	0	0	0	0	0	0	0	0	0	
	15	14	13	12	11	10	9	8	7	6	5	4	3	2	1	0	
	reserved														VECT	reserved	
Type	RO	RO	RO	RO	RO	RO	RO	RO	RO	RO	RO	RO	RO	RO	RO	RW1C	RO
Reset	0	0	0	0	0	0	0	0	0	0	0	0	0	0	0	0	0

Bit/Field	Name	Type	Reset	Description
31	DBG	RW1C	0	Debug Event This bit is reserved for Debug use. This bit must be written as a 0, otherwise behavior is unpredictable.
30	FORCED	RW1C	0	Forced Hard Fault Value Description 0 No forced hard fault has occurred. 1 A forced hard fault has been generated by escalation of a fault with configurable priority that cannot be handled, either because of priority or because it is disabled. When this bit is set, the hard fault handler must read the other fault status registers to find the cause of the fault. This bit is cleared by writing a 1 to it.
29:2	reserved	RO	0x00	Software should not rely on the value of a reserved bit. To provide compatibility with future products, the value of a reserved bit should be preserved across a read-modify-write operation.
1	VECT	RW1C	0	Vector Table Read Fault Value Description 0 No bus fault has occurred on a vector table read. 1 A bus fault occurred on a vector table read. This error is always handled by the hard fault handler. When this bit is set, the PC value stacked for the exception return points to the instruction that was preempted by the exception. This bit is cleared by writing a 1 to it.
0	reserved	RO	0	Software should not rely on the value of a reserved bit. To provide compatibility with future products, the value of a reserved bit should be preserved across a read-modify-write operation.

Register 67: Memory Management Fault Address (MMADDR), offset 0xD34

Note: This register can only be accessed from privileged mode.

The **MMADDR** register contains the address of the location that generated a memory management fault. When an unaligned access faults, the address in the **MMADDR** register is the actual address that faulted. Because a single read or write instruction can be split into multiple aligned accesses, the fault address can be any address in the range of the requested access size. Bits in the **Memory Management Fault Status (MFAULTSTAT)** register indicate the cause of the fault and whether the value in the **MMADDR** register is valid (see page 191).

Memory Management Fault Address (MMADDR)

Base 0xE000.E000

Offset 0xD34

Type RW, reset -

	31	30	29	28	27	26	25	24	23	22	21	20	19	18	17	16
	ADDR															
Type	RW	RW	RW	RW	RW	RW	RW	RW	RW	RW	RW	RW	RW	RW	RW	RW
Reset	-	-	-	-	-	-	-	-	-	-	-	-	-	-	-	-
	15	14	13	12	11	10	9	8	7	6	5	4	3	2	1	0
	ADDR															
Type	RW	RW	RW	RW	RW	RW	RW	RW	RW	RW	RW	RW	RW	RW	RW	RW
Reset	-	-	-	-	-	-	-	-	-	-	-	-	-	-	-	-

Bit/Field	Name	Type	Reset	Description
31:0	ADDR	RW	-	Fault Address When the MMARV bit of MFAULTSTAT is set, this field holds the address of the location that generated the memory management fault.

Register 68: Bus Fault Address (FAULTADDR), offset 0xD38

Note: This register can only be accessed from privileged mode.

The **FAULTADDR** register contains the address of the location that generated a bus fault. When an unaligned access faults, the address in the **FAULTADDR** register is the one requested by the instruction, even if it is not the address of the fault. Bits in the **Bus Fault Status (BFAULTSTAT)** register indicate the cause of the fault and whether the value in the **FAULTADDR** register is valid (see page 191).

Bus Fault Address (FAULTADDR)

Base 0xE000.E000

Offset 0xD38

Type RW, reset -

	31	30	29	28	27	26	25	24	23	22	21	20	19	18	17	16
	ADDR															
Type	RW	RW	RW	RW	RW	RW	RW	RW	RW	RW	RW	RW	RW	RW	RW	RW
Reset	-	-	-	-	-	-	-	-	-	-	-	-	-	-	-	-
	15	14	13	12	11	10	9	8	7	6	5	4	3	2	1	0
	ADDR															
Type	RW	RW	RW	RW	RW	RW	RW	RW	RW	RW	RW	RW	RW	RW	RW	RW
Reset	-	-	-	-	-	-	-	-	-	-	-	-	-	-	-	-

Bit/Field	Name	Type	Reset	Description
31:0	ADDR	RW	-	Fault Address When the FAULTADDRV bit of BFAULTSTAT is set, this field holds the address of the location that generated the bus fault.

3.6 Memory Protection Unit (MPU) Register Descriptions

This section lists and describes the Memory Protection Unit (MPU) registers, in numerical order by address offset.

The MPU registers can only be accessed from privileged mode.

Register 69: MPU Type (MPUTYPE), offset 0xD90

Note: This register can only be accessed from privileged mode.

The **MPUTYPE** register indicates whether the MPU is present, and if so, how many regions it supports.

MPU Type (MPUTYPE)

Base 0xE000.E000

Offset 0xD90

Type RO, reset 0x0000.0800

	31	30	29	28	27	26	25	24	23	22	21	20	19	18	17	16
	reserved								IREGION							
Type	RO	RO	RO	RO	RO	RO	RO	RO	RO	RO	RO	RO	RO	RO	RO	RO
Reset	0	0	0	0	0	0	0	0	0	0	0	0	0	0	0	0
	15	14	13	12	11	10	9	8	7	6	5	4	3	2	1	0
	DREGION								reserved							SEPARATE
Type	RO	RO	RO	RO	RO	RO	RO	RO	RO	RO	RO	RO	RO	RO	RO	RO
Reset	0	0	0	0	1	0	0	0	0	0	0	0	0	0	0	0

Bit/Field	Name	Type	Reset	Description
31:24	reserved	RO	0x00	Software should not rely on the value of a reserved bit. To provide compatibility with future products, the value of a reserved bit should be preserved across a read-modify-write operation.
23:16	IREGION	RO	0x00	Number of I Regions This field indicates the number of supported MPU instruction regions. This field always contains 0x00. The MPU memory map is unified and is described by the DREGION field.
15:8	DREGION	RO	0x08	Number of D Regions Value Description 0x08 Indicates there are eight supported MPU data regions.
7:1	reserved	RO	0x00	Software should not rely on the value of a reserved bit. To provide compatibility with future products, the value of a reserved bit should be preserved across a read-modify-write operation.
0	SEPARATE	RO	0	Separate or Unified MPU Value Description 0 Indicates the MPU is unified.

Register 70: MPU Control (MPUCTRL), offset 0xD94

Note: This register can only be accessed from privileged mode.

The **MPUCTRL** register enables the MPU, enables the default memory map background region, and enables use of the MPU when in the hard fault, Non-maskable Interrupt (NMI), and **Fault Mask Register (FAULTMASK)** escalated handlers.

When the **ENABLE** and **PRIVDEFEN** bits are both set:

- For privileged accesses, the default memory map is as described in “Memory Model” on page 109. Any access by privileged software that does not address an enabled memory region behaves as defined by the default memory map.
- Any access by unprivileged software that does not address an enabled memory region causes a memory management fault.

Execute Never (XN) and Strongly Ordered rules always apply to the System Control Space regardless of the value of the **ENABLE** bit.

When the **ENABLE** bit is set, at least one region of the memory map must be enabled for the system to function unless the **PRIVDEFEN** bit is set. If the **PRIVDEFEN** bit is set and no regions are enabled, then only privileged software can operate.

When the **ENABLE** bit is clear, the system uses the default memory map, which has the same memory attributes as if the MPU is not implemented (see Table 2-5 on page 113 for more information). The default memory map applies to accesses from both privileged and unprivileged software.

When the MPU is enabled, accesses to the System Control Space and vector table are always permitted. Other areas are accessible based on regions and whether **PRIVDEFEN** is set.

Unless **HFNMIENA** is set, the MPU is not enabled when the processor is executing the handler for an exception with priority –1 or –2. These priorities are only possible when handling a hard fault or NMI exception or when **FAULTMASK** is enabled. Setting the **HFNMIENA** bit enables the MPU when operating with these two priorities.

MPU Control (MPUCTRL)

Base 0xE000.E000
Offset 0xD94
Type RW, reset 0x0000.0000

	31	30	29	28	27	26	25	24	23	22	21	20	19	18	17	16	
	reserved																
Type	RO	RO	RO	RO	RO	RO	RO	RO	RO	RO	RO	RO	RO	RO	RO	RO	
Reset	0	0	0	0	0	0	0	0	0	0	0	0	0	0	0	0	
	15	14	13	12	11	10	9	8	7	6	5	4	3	2	1	0	
	reserved													PRIVDEFEN	HFNMIENA	ENABLE	
Type	RO	RO	RO	RO	RO	RO	RO	RO	RO	RO	RO	RO	RO	RO	RW	RW	RW
Reset	0	0	0	0	0	0	0	0	0	0	0	0	0	0	0	0	0

Bit/Field	Name	Type	Reset	Description
31:3	reserved	RO	0x0000.000	Software should not rely on the value of a reserved bit. To provide compatibility with future products, the value of a reserved bit should be preserved across a read-modify-write operation.

Bit/Field	Name	Type	Reset	Description
2	PRIVDEFEN	RW	0	<p>MPU Default Region</p> <p>This bit enables privileged software access to the default memory map.</p> <p>Value Description</p> <p>0 If the MPU is enabled, this bit disables use of the default memory map. Any memory access to a location not covered by any enabled region causes a fault.</p> <p>1 If the MPU is enabled, this bit enables use of the default memory map as a background region for privileged software accesses.</p> <p>When this bit is set, the background region acts as if it is region number -1. Any region that is defined and enabled has priority over this default map.</p> <p>If the MPU is disabled, the processor ignores this bit.</p>
1	HFNMIENA	RW	0	<p>MPU Enabled During Faults</p> <p>This bit controls the operation of the MPU during hard fault, NMI, and FAULTMASK handlers.</p> <p>Value Description</p> <p>0 The MPU is disabled during hard fault, NMI, and FAULTMASK handlers, regardless of the value of the <i>ENABLE</i> bit.</p> <p>1 The MPU is enabled during hard fault, NMI, and FAULTMASK handlers.</p> <p>When the MPU is disabled and this bit is set, the resulting behavior is unpredictable.</p>
0	ENABLE	RW	0	<p>MPU Enable</p> <p>Value Description</p> <p>0 The MPU is disabled.</p> <p>1 The MPU is enabled.</p> <p>When the MPU is disabled and the <i>HFNMIENA</i> bit is set, the resulting behavior is unpredictable.</p>

Register 71: MPU Region Number (MPUNUMBER), offset 0xD98

Note: This register can only be accessed from privileged mode.

The **MPUNUMBER** register selects which memory region is referenced by the **MPU Region Base Address (MPUBASE)** and **MPU Region Attribute and Size (MPUATTR)** registers. Normally, the required region number should be written to this register before accessing the **MPUBASE** or the **MPUATTR** register. However, the region number can be changed by writing to the **MPUBASE** register with the **VALID** bit set (see page 204). This write updates the value of the **REGION** field.

MPU Region Number (MPUNUMBER)

Base 0xE000.E000

Offset 0xD98

Type RW, reset 0x0000.0000

	31	30	29	28	27	26	25	24	23	22	21	20	19	18	17	16	
	reserved																
Type	RO	RO	RO	RO	RO	RO	RO	RO	RO	RO	RO	RO	RO	RO	RO	RO	
Reset	0	0	0	0	0	0	0	0	0	0	0	0	0	0	0	0	
	15	14	13	12	11	10	9	8	7	6	5	4	3	2	1	0	
	reserved													NUMBER			
Type	RO	RO	RO	RO	RO	RO	RO	RO	RO	RO	RO	RO	RO	RO	RW	RW	RW
Reset	0	0	0	0	0	0	0	0	0	0	0	0	0	0	0	0	0

Bit/Field	Name	Type	Reset	Description
31:3	reserved	RO	0x0000.000	Software should not rely on the value of a reserved bit. To provide compatibility with future products, the value of a reserved bit should be preserved across a read-modify-write operation.
2:0	NUMBER	RW	0x0	MPU Region to Access This field indicates the MPU region referenced by the MPUBASE and MPUATTR registers. The MPU supports eight memory regions.

Register 72: MPU Region Base Address (MPUBASE), offset 0xD9C

Register 73: MPU Region Base Address Alias 1 (MPUBASE1), offset 0xDA4

Register 74: MPU Region Base Address Alias 2 (MPUBASE2), offset 0xDAC

Register 75: MPU Region Base Address Alias 3 (MPUBASE3), offset 0xDB4

Note: This register can only be accessed from privileged mode.

The **MPUBASE** register defines the base address of the MPU region selected by the **MPU Region Number (MPUNUMBER)** register and can update the value of the **MPUNUMBER** register. To change the current region number and update the **MPUNUMBER** register, write the **MPUBASE** register with the **VALID** bit set.

The **ADDR** field is bits 31:*N* of the **MPUBASE** register. Bits (*N*-1):5 are reserved. The region size, as specified by the **SIZE** field in the **MPU Region Attribute and Size (MPUATTR)** register, defines the value of *N* where:

$$N = \text{Log}_2(\text{Region size in bytes})$$

If the region size is configured to 4 GB in the **MPUATTR** register, there is no valid **ADDR** field. In this case, the region occupies the complete memory map, and the base address is 0x0000.0000.

The base address is aligned to the size of the region. For example, a 64-KB region must be aligned on a multiple of 64 KB, for example, at 0x0001.0000 or 0x0002.0000.

MPU Region Base Address (MPUBASE)

Base 0xE000.E000
 Offset 0xD9C
 Type RW, reset 0x0000.0000

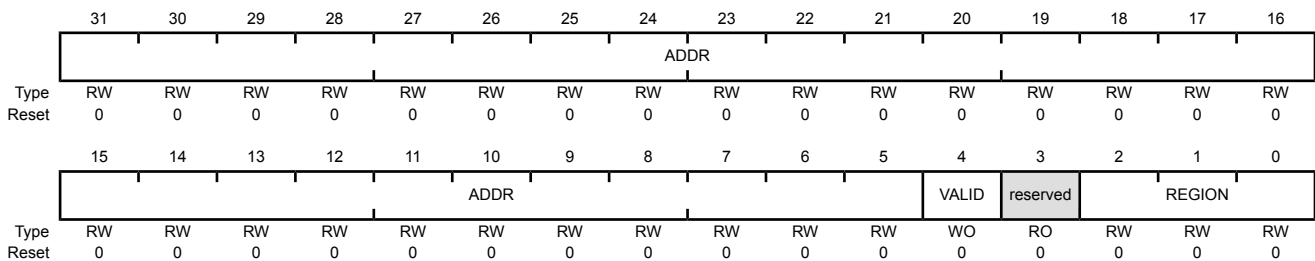

Bit/Field	Name	Type	Reset	Description
31:5	ADDR	RW	0x0000.000	<p>Base Address Mask</p> <p>Bits 31:<i>N</i> in this field contain the region base address. The value of <i>N</i> depends on the region size, as shown above. The remaining bits (<i>N</i>-1):5 are reserved.</p> <p>Software should not rely on the value of a reserved bit. To provide compatibility with future products, the value of a reserved bit should be preserved across a read-modify-write operation.</p>

Bit/Field	Name	Type	Reset	Description
4	VALID	WO	0	<p>Region Number Valid</p> <p>Value Description</p> <p>0 The MPUNUMBER register is not changed and the processor updates the base address for the region specified in the MPUNUMBER register and ignores the value of the REGION field.</p> <p>1 The MPUNUMBER register is updated with the value of the REGION field and the base address is updated for the region specified in the REGION field.</p> <p>This bit is always read as 0.</p>
3	reserved	RO	0	Software should not rely on the value of a reserved bit. To provide compatibility with future products, the value of a reserved bit should be preserved across a read-modify-write operation.
2:0	REGION	RW	0x0	<p>Region Number</p> <p>On a write, contains the value to be written to the MPUNUMBER register. On a read, returns the current region number in the MPUNUMBER register.</p>

Register 76: MPU Region Attribute and Size (MPUATTR), offset 0xDA0**Register 77: MPU Region Attribute and Size Alias 1 (MPUATTR1), offset 0xDA8****Register 78: MPU Region Attribute and Size Alias 2 (MPUATTR2), offset 0xDB0****Register 79: MPU Region Attribute and Size Alias 3 (MPUATTR3), offset 0xDB8**

Note: This register can only be accessed from privileged mode.

The **MPUATTR** register defines the region size and memory attributes of the MPU region specified by the **MPU Region Number (MPUNUMBER)** register and enables that region and any subregions.

The **MPUATTR** register is accessible using word or halfword accesses with the most-significant halfword holding the region attributes and the least-significant halfword holds the region size and the region and subregion enable bits.

The MPU access permission attribute bits, **XN**, **AP**, **TEX**, **S**, **C**, and **B**, control access to the corresponding memory region. If an access is made to an area of memory without the required permissions, then the MPU generates a permission fault.

The **SIZE** field defines the size of the MPU memory region specified by the **MPUNUMBER** register as follows:

$$(\text{Region size in bytes}) = 2^{(\text{SIZE}+1)}$$

The smallest permitted region size is 32 bytes, corresponding to a **SIZE** value of 4. Table 3-10 on page 206 gives example **SIZE** values with the corresponding region size and value of **N** in the **MPU Region Base Address (MPUBASE)** register.

Table 3-10. Example SIZE Field Values

SIZE Encoding	Region Size	Value of N ^a	Note
00100b (0x4)	32 B	5	Minimum permitted size
01001b (0x9)	1 KB	10	-
10011b (0x13)	1 MB	20	-
11101b (0x1D)	1 GB	30	-
11111b (0x1F)	4 GB	No valid ADDR field in MPUBASE ; the region occupies the complete memory map.	Maximum possible size

a. Refers to the **N** parameter in the **MPUBASE** register (see page 204).

MPU Region Attribute and Size (MPUATTR)

Base 0xE000.E000

Offset 0xDA0

Type RW, reset 0x0000.0000

	31	30	29	28	27	26	25	24	23	22	21	20	19	18	17	16
	reserved			XN	reserved	AP		reserved			TEX		S	C	B	
Type	RO	RO	RO	RW	RO	RW	RW	RW	RO	RO	RW	RW	RW	RW	RW	
Reset	0	0	0	0	0	0	0	0	0	0	0	0	0	0	0	
	15	14	13	12	11	10	9	8	7	6	5	4	3	2	1	0
	SRD							reserved			SIZE				ENABLE	
Type	RW	RW	RW	RW	RW	RW	RW	RW	RO	RO	RW	RW	RW	RW	RW	
Reset	0	0	0	0	0	0	0	0	0	0	0	0	0	0	0	

Bit/Field	Name	Type	Reset	Description
31:29	reserved	RO	0x00	Software should not rely on the value of a reserved bit. To provide compatibility with future products, the value of a reserved bit should be preserved across a read-modify-write operation.
28	XN	RW	0	Instruction Access Disable Value Description 0 Instruction fetches are enabled. 1 Instruction fetches are disabled.
27	reserved	RO	0	Software should not rely on the value of a reserved bit. To provide compatibility with future products, the value of a reserved bit should be preserved across a read-modify-write operation.
26:24	AP	RW	0	Access Privilege For information on using this bit field, see Table 3-5 on page 148.
23:22	reserved	RO	0x0	Software should not rely on the value of a reserved bit. To provide compatibility with future products, the value of a reserved bit should be preserved across a read-modify-write operation.
21:19	TEX	RW	0x0	Type Extension Mask For information on using this bit field, see Table 3-3 on page 147.
18	S	RW	0	Shareable For information on using this bit, see Table 3-3 on page 147.
17	C	RW	0	Cacheable For information on using this bit, see Table 3-3 on page 147.
16	B	RW	0	Bufferable For information on using this bit, see Table 3-3 on page 147.
15:8	SRD	RW	0x00	Subregion Disable Bits Value Description 0 The corresponding subregion is enabled. 1 The corresponding subregion is disabled. Region sizes of 128 bytes and less do not support subregions. When writing the attributes for such a region, configure the SRD field as 0x00. See the section called "Subregions" on page 147 for more information.
7:6	reserved	RO	0x0	Software should not rely on the value of a reserved bit. To provide compatibility with future products, the value of a reserved bit should be preserved across a read-modify-write operation.
5:1	SIZE	RW	0x0	Region Size Mask The SIZE field defines the size of the MPU memory region specified by the MPUNUMBER register. Refer to Table 3-10 on page 206 for more information.

Bit/Field	Name	Type	Reset	Description
0	ENABLE	RW	0	Region Enable
				Value Description
			0	The region is disabled.
			1	The region is enabled.

3.7 Floating-Point Unit (FPU) Register Descriptions

This section lists and describes the Floating-Point Unit (FPU) registers, in numerical order by address offset.

Register 80: Coprocessor Access Control (CPAC), offset 0xD88

The **CPAC** register specifies the access privileges for coprocessors.

Coprocessor Access Control (CPAC)

Base 0xE000.E000

Offset 0xD88

Type RW, reset 0x0000.0000

	31	30	29	28	27	26	25	24	23	22	21	20	19	18	17	16
	reserved								CP11		CP10		reserved			
Type	RO	RO	RO	RO	RO	RO	RO	RO	RW	RW	RW	RW	RO	RO	RO	RO
Reset	0	0	0	0	0	0	0	0	0	0	0	0	0	0	0	0
	15	14	13	12	11	10	9	8	7	6	5	4	3	2	1	0
	reserved															
Type	RO	RO	RO	RO	RO	RO	RO	RO	RO	RO	RO	RO	RO	RO	RO	RO
Reset	0	0	0	0	0	0	0	0	0	0	0	0	0	0	0	0

Bit/Field	Name	Type	Reset	Description
31:24	reserved	RO	0x00	Software should not rely on the value of a reserved bit. To provide compatibility with future products, the value of a reserved bit should be preserved across a read-modify-write operation.
23:22	CP11	RW	0x00	CP11 Coprocessor Access Privilege Value Description 0x0 Access Denied Any attempted access generates a NOCP Usage Fault. 0x1 Privileged Access Only An unprivileged access generates a NOCP fault. 0x2 Reserved The result of any access is unpredictable. 0x3 Full Access
21:20	CP10	RW	0x00	CP10 Coprocessor Access Privilege Value Description 0x0 Access Denied Any attempted access generates a NOCP Usage Fault. 0x1 Privileged Access Only An unprivileged access generates a NOCP fault. 0x2 Reserved The result of any access is unpredictable. 0x3 Full Access
19:0	reserved	RO	0x00	Software should not rely on the value of a reserved bit. To provide compatibility with future products, the value of a reserved bit should be preserved across a read-modify-write operation.

Register 81: Floating-Point Context Control (FPCC), offset 0xF34

The **FPCC** register sets or returns FPU control data.

Floating-Point Context Control (FPCC)

Base 0xE000.E000

Offset 0xF34

Type RW, reset 0xC000.0000

	31	30	29	28	27	26	25	24	23	22	21	20	19	18	17	16
	ASPEN	LSPEN	reserved													
Type	RW	RW	RO	RO	RO	RO	RO	RO	RO	RO	RO	RO	RO	RO	RO	RO
Reset	1	1	0	0	0	0	0	0	0	0	0	0	0	0	0	0
	15	14	13	12	11	10	9	8	7	6	5	4	3	2	1	0
	reserved							MONRDY	reserved	BFRDY	MMRDY	HFRDY	THREAD	reserved	USER	LSPACT
Type	RO	RO	RO	RO	RO	RO	RO	RW	RO	RW	RW	RW	RW	RO	RW	RW
Reset	0	0	0	0	0	0	0	0	0	0	0	0	0	0	0	0

Bit/Field	Name	Type	Reset	Description
31	ASPEN	RW	1	<p>Automatic State Preservation Enable</p> <p>When set, enables the use of the <code>FRACTV</code> bit in the CONTROL register on execution of a floating-point instruction. This results in automatic hardware state preservation and restoration, for floating-point context, on exception entry and exit.</p> <hr/> <p>Important: Two bits control when <code>FPCA</code> can be enabled: the <code>ASPEN</code> bit in the Floating-Point Context Control (FPCC) register and the <code>DISFPCA</code> bit in the Auxiliary Control (ACTLR) register.</p> <hr/>
30	LSPEN	RW	1	<p>Lazy State Preservation Enable</p> <p>When set, enables automatic lazy state preservation for floating-point context.</p>
29:9	reserved	RO	0x00	<p>Software should not rely on the value of a reserved bit. To provide compatibility with future products, the value of a reserved bit should be preserved across a read-modify-write operation.</p>
8	MONRDY	RW	0	<p>Monitor Ready</p> <p>When set, DebugMonitor is enabled and priority permits setting <code>MON_PEND</code> when the floating-point stack frame was allocated.</p>
7	reserved	RO	0	<p>Software should not rely on the value of a reserved bit. To provide compatibility with future products, the value of a reserved bit should be preserved across a read-modify-write operation.</p>
6	BFRDY	RW	0	<p>Bus Fault Ready</p> <p>When set, BusFault is enabled and priority permitted setting the BusFault handler to the pending state when the floating-point stack frame was allocated.</p>
5	MMRDY	RW	0	<p>Memory Management Fault Ready</p> <p>When set, MemManage is enabled and priority permitted setting the MemManage handler to the pending state when the floating-point stack frame was allocated.</p>

Bit/Field	Name	Type	Reset	Description
4	HFRDY	RW	0	Hard Fault Ready When set, priority permitted setting the HardFault handler to the pending state when the floating-point stack frame was allocated.
3	THREAD	RW	0	Thread Mode When set, mode was Thread Mode when the floating-point stack frame was allocated.
2	reserved	RO	0	Software should not rely on the value of a reserved bit. To provide compatibility with future products, the value of a reserved bit should be preserved across a read-modify-write operation.
1	USER	RW	0	User Privilege Level When set, privilege level was user when the floating-point stack frame was allocated.
0	LSPACT	RW	0	Lazy State Preservation Active When set, Lazy State preservation is active. Floating-point stack frame has been allocated but saving state to it has been deferred.

Register 82: Floating-Point Context Address (FPCA), offset 0xF38

The **FPCA** register holds the location of the unpopulated floating-point register space allocated on an exception stack frame.

Floating-Point Context Address (FPCA)

Base 0xE000.E000

Offset 0xF38

Type RW, reset -

	31	30	29	28	27	26	25	24	23	22	21	20	19	18	17	16
	ADDRESS															
Type	RW	RW	RW	RW	RW	RW	RW	RW	RW	RW	RW	RW	RW	RW	RW	RW
Reset	-	-	-	-	-	-	-	-	-	-	-	-	-	-	-	-
	15	14	13	12	11	10	9	8	7	6	5	4	3	2	1	0
	ADDRESS													reserved		
Type	RW	RW	RW	RW	RW	RW	RW	RW	RW	RW	RW	RW	RW	RO	RO	RO
Reset	-	-	-	-	-	-	-	-	-	-	-	-	-	0	0	0

Bit/Field	Name	Type	Reset	Description
31:3	ADDRESS	RW	-	Address The location of the unpopulated floating-point register space allocated on an exception stack frame.
2:0	reserved	RO	0x00	Software should not rely on the value of a reserved bit. To provide compatibility with future products, the value of a reserved bit should be preserved across a read-modify-write operation.

Register 83: Floating-Point Default Status Control (FPDSC), offset 0xF3C

The **FPDSC** register holds the default values for the **Floating-Point Status Control (FPSC)** register.

Floating-Point Default Status Control (FPDSC)

Base 0xE000.E000

Offset 0xF3C

Type RW, reset 0x0000.0000

	31	30	29	28	27	26	25	24	23	22	21	20	19	18	17	16
	reserved					AHP	DN	FZ	RMODE		reserved					
Type	RO	RO	RO	RO	RO	RW	RW	RW	RW	RW	RO	RO	RO	RO	RO	RO
Reset	0	0	0	0	0	-	-	-	-	-	0	0	0	0	0	0
	15	14	13	12	11	10	9	8	7	6	5	4	3	2	1	0
	reserved															
Type	RO	RO	RO	RO	RO	RO	RO	RO	RO	RO	RO	RO	RO	RO	RO	RO
Reset	0	0	0	0	0	0	0	0	0	0	0	0	0	0	0	0

Bit/Field	Name	Type	Reset	Description										
31:27	reserved	RO	0x00	Software should not rely on the value of a reserved bit. To provide compatibility with future products, the value of a reserved bit should be preserved across a read-modify-write operation.										
26	AHP	RW	-	AHP Bit Default This bit holds the default value for the AHP bit in the FPSC register.										
25	DN	RW	-	DN Bit Default This bit holds the default value for the DN bit in the FPSC register.										
24	FZ	RW	-	FZ Bit Default This bit holds the default value for the FZ bit in the FPSC register.										
23:22	RMODE	RW	-	RMODE Bit Default This bit holds the default value for the RMODE bit field in the FPSC register. <table border="0"> <tr> <td>Value</td> <td>Description</td> </tr> <tr> <td>0x0</td> <td>Round to Nearest (RN) mode</td> </tr> <tr> <td>0x1</td> <td>Round towards Plus Infinity (RP) mode</td> </tr> <tr> <td>0x2</td> <td>Round towards Minus Infinity (RM) mode</td> </tr> <tr> <td>0x3</td> <td>Round towards Zero (RZ) mode</td> </tr> </table>	Value	Description	0x0	Round to Nearest (RN) mode	0x1	Round towards Plus Infinity (RP) mode	0x2	Round towards Minus Infinity (RM) mode	0x3	Round towards Zero (RZ) mode
Value	Description													
0x0	Round to Nearest (RN) mode													
0x1	Round towards Plus Infinity (RP) mode													
0x2	Round towards Minus Infinity (RM) mode													
0x3	Round towards Zero (RZ) mode													
21:0	reserved	RO	0x00	Software should not rely on the value of a reserved bit. To provide compatibility with future products, the value of a reserved bit should be preserved across a read-modify-write operation.										

4 JTAG Interface

The Joint Test Action Group (JTAG) port is an IEEE standard that defines a Test Access Port and Boundary Scan Architecture for digital integrated circuits and provides a standardized serial interface for controlling the associated test logic. The TAP, Instruction Register (IR), and Data Registers (DR) can be used to test the interconnections of assembled printed circuit boards and obtain manufacturing information on the components. The JTAG Port also provides a means of accessing and controlling design-for-test features such as I/O pin observation and control, scan testing, and debugging.

The JTAG port is comprised of four pins: TCK, TMS, TDI, and TDO. Data is transmitted serially into the controller on TDI and out of the controller on TDO. The interpretation of this data is dependent on the current state of the TAP controller. For detailed information on the operation of the JTAG port and TAP controller, please refer to the *IEEE Standard 1149.1-Test Access Port and Boundary-Scan Architecture*.

The TM4C129ENCPDT JTAG controller works with the ARM JTAG controller built into the Cortex-M4F core by multiplexing the TDO outputs from both JTAG controllers. ARM JTAG instructions select the ARM TDO output while JTAG instructions select the TDO output. The multiplexer is controlled by the JTAG controller, which has comprehensive programming for the ARM, Tiva™ C Series microcontroller, and unimplemented JTAG instructions.

The TM4C129ENCPDT JTAG module has the following features:

- IEEE 1149.1-1990 compatible Test Access Port (TAP) controller
- Four-bit Instruction Register (IR) chain for storing JTAG instructions
- IEEE standard instructions: BYPASS, IDCODE, SAMPLE/PRELOAD, and EXTEST
- ARM additional instructions: APACC, DPACC and ABORT
- Integrated ARM Serial Wire Debug (SWD)
 - Serial Wire JTAG Debug Port (SWJ-DP)
 - Flash Patch and Breakpoint (FPB) unit for implementing breakpoints
 - Data Watchpoint and Trace (DWT) unit for implementing watchpoints, trigger resources, and system profiling
 - Instrumentation Trace Macrocell (ITM) for support of printf style debugging
 - Embedded Trace Macrocell (ETM) for instruction trace capture
 - Trace Port Interface Unit (TPIU) for bridging to a Trace Port Analyzer

See the *ARM® Debug Interface V5 Architecture Specification* for more information on the ARM JTAG controller.

4.1 Block Diagram

Figure 4-1. JTAG Module Block Diagram



4.2 Signal Description

The following table lists the external signals of the JTAG/SWD controller and describes the function of each. The JTAG/SWD controller signals are alternate functions for some GPIO signals, however note that the reset state of the pins is for the JTAG/SWD function. The JTAG/SWD controller signals are under commit protection and require a special process to be configured as GPIOs, see “Commit Control” on page 760. The column in the table below titled “Pin Mux/Pin Assignment” lists the GPIO pin placement for the JTAG/SWD controller signals. The **AFSEL** bit in the **GPIO Alternate Function Select (GPIOAFSEL)** register (page 778) is set to choose the JTAG/SWD function. The number in parentheses is the encoding that must be programmed into the **PMC_n** field in the **GPIO Port Control (GPIOPTL)** register (page 795) to assign the JTAG/SWD controller signals to the specified GPIO port pin. For more information on configuring GPIOs, see “General-Purpose Input/Outputs (GPIOs)” on page 750.

Table 4-1. JTAG_SWD_SWO Signals (128TQFP)

Pin Name	Pin Number	Pin Mux / Pin Assignment	Pin Type	Buffer Type	Description
SWCLK	100	PC0 (1)	I	TTL	JTAG/SWD CLK.
SWDIO	99	PC1 (1)	I/O	TTL	JTAG TMS and SWDIO.
SWO	97	PC3 (1)	O	TTL	JTAG TDO and SWO.
TCK	100	PC0 (1)	I	TTL	JTAG/SWD CLK.
TDI	98	PC2 (1)	I	TTL	JTAG TDI.
TDO	97	PC3 (1)	O	TTL	JTAG TDO and SWO.
TMS	99	PC1 (1)	I	TTL	JTAG TMS and SWDIO.

4.3 Functional Description

A high-level conceptual drawing of the JTAG module is shown in Figure 4-1 on page 215. The JTAG module is composed of the Test Access Port (TAP) controller and serial shift chains with parallel update registers. The TAP controller is a simple state machine controlled by the TCK and TMS inputs. The current state of the TAP controller depends on the sequence of values captured on TMS at the rising edge of TCK. The TAP controller determines when the serial shift chains capture new data, shift data from TDI towards TDO, and update the parallel load registers. The current state of the TAP controller also determines whether the Instruction Register (IR) chain or one of the Data Register (DR) chains is being accessed.

The serial shift chains with parallel load registers are comprised of a single Instruction Register (IR) chain and multiple Data Register (DR) chains. The current instruction loaded in the parallel load register determines which DR chain is captured, shifted, or updated during the sequencing of the TAP controller.

Some instructions, like EXTEST, operate on data currently in a DR chain and do not capture, shift, or update any of the chains. Instructions that are not implemented decode to the BYPASS instruction to ensure that the serial path between TDI and TDO is always connected (see Table 4-3 on page 223 for a list of implemented instructions).

See “JTAG and Boundary Scan” on page 1948 for JTAG timing diagrams.

Depending on the reset source, the effect on the JTAG module varies. The following reset sources reset the entire JTAG Module:

- Externally generated Power-On Reset

The following reset sources reset only the JTAG pin configuration:

- $\overline{\text{RST}}$ pin Power-On Reset
- Brown-Out Power-On Reset
- Watchdog Power-On Reset
- HIB Module Power-On Reset
- $\overline{\text{RST}}$ pin System Reset
- Brown-Out System Reset
- Software System Reset Request (using the SYSRESREQ bit in the **APINT** register)
- Software Peripheral Reset
- Watchdog System Reset
- HIB Module System Reset

4.3.1 JTAG Interface Pins

The JTAG interface consists of four standard pins: TCK, TMS, TDI, and TDO. These pins and their associated state after a power-on reset or reset caused by the $\overline{\text{RST}}$ input are given in Table 4-2. Detailed information on each pin follows.

Note: The following pins are configured as JTAG port pins out of reset. Refer to “General-Purpose Input/Outputs (GPIOs)” on page 750 for information on how to reprogram the configuration of these pins.

Table 4-2. JTAG Port Pins State after Power-On Reset or $\overline{\text{RST}}$ assertion

Pin Name	Data Direction	Internal Pull-Up	Internal Pull-Down	Drive Strength	Drive Value
TCK	Input	Enabled	Disabled	N/A	N/A
TMS	Input	Enabled	Disabled	N/A	N/A
TDI	Input	Enabled	Disabled	N/A	N/A
TDO	Output	Enabled	Disabled	2-mA driver	High-Z

4.3.1.1 Test Clock Input (TCK)

The TCK pin is the clock for the JTAG module. This clock is provided so the test logic can operate independently of any other system clocks and to ensure that multiple JTAG TAP controllers that are daisy-chained together can synchronously communicate serial test data between components. During normal operation, TCK is driven by a free-running clock with a nominal 50% duty cycle. When necessary, TCK can be stopped at 0 or 1 for extended periods of time. While TCK is stopped at 0 or 1, the state of the TAP controller does not change and data in the JTAG Instruction and Data Registers is not lost.

By default, the internal pull-up resistor on the TCK pin is enabled after reset, assuring that no clocking occurs if the pin is not driven from an external source. The internal pull-up and pull-down resistors can be turned off to save internal power as long as the TCK pin is constantly being driven by an external source (see page 784 and page 786).

4.3.1.2 Test Mode Select (TMS)

The TMS pin selects the next state of the JTAG TAP controller. TMS is sampled on the rising edge of TCK. Depending on the current TAP state and the sampled value of TMS, the next state may be entered. Because the TMS pin is sampled on the rising edge of TCK, the *IEEE Standard 1149.1* expects the value on TMS to change on the falling edge of TCK.

Holding TMS high for five consecutive TCK cycles drives the TAP controller state machine to the Test-Logic-Reset state. When the TAP controller enters the Test-Logic-Reset state, the JTAG module and associated registers are reset to their default values. This procedure should be performed to initialize the JTAG controller. The JTAG Test Access Port state machine can be seen in its entirety in Figure 4-2 on page 219.

By default, the internal pull-up resistor on the TMS pin is enabled after reset. Changes to the pull-up resistor settings on GPIO Port C should ensure that the internal pull-up resistor remains enabled on PC1/TMS; otherwise JTAG communication could be lost (see page 784).

4.3.1.3 Test Data Input (TDI)

The TDI pin provides a stream of serial information to the IR chain and the DR chains. TDI is sampled on the rising edge of TCK and, depending on the current TAP state and the current instruction, may present this data to the proper shift register chain. Because the TDI pin is sampled on the rising edge of TCK, the *IEEE Standard 1149.1* expects the value on TDI to change on the falling edge of TCK.

By default, the internal pull-up resistor on the TDI pin is enabled after reset. Changes to the pull-up resistor settings on GPIO Port C should ensure that the internal pull-up resistor remains enabled on PC2/TDI; otherwise JTAG communication could be lost (see page 784).

4.3.1.4 Test Data Output (TDO)

The TDO pin provides an output stream of serial information from the IR chain or the DR chains. The value of TDO depends on the current TAP state, the current instruction, and the data in the chain being accessed. In order to save power when the JTAG port is not being used, the TDO pin is placed in an inactive drive state when not actively shifting out data. Because TDO can be connected to the TDI of another controller in a daisy-chain configuration, the *IEEE Standard 1149.1* expects the value on TDO to change on the falling edge of TCK.

By default, the internal pull-up resistor on the TDO pin is enabled after reset, assuring that the pin remains at a constant logic level when the JTAG port is not being used. The internal pull-up and pull-down resistors can be turned off to save internal power if a High-Z output value is acceptable during certain TAP controller states (see page 784 and page 786).

Note: If the device fails initialization during reset, the hardware toggles the TDO output as an indication of failure. Thus, during board layout, designers should not designate the TDO pin as a GPIO in sensitive applications where the possibility of toggling could affect the design.

4.3.2 JTAG TAP Controller

The JTAG TAP controller state machine is shown in Figure 4-2. The TAP controller state machine is reset to the Test-Logic-Reset state on the assertion of a Power-On-Reset (POR). In order to reset the JTAG module after the microcontroller has been powered on, the TMS input must be held HIGH for five TCK clock cycles, resetting the TAP controller and all associated JTAG chains. Asserting the correct sequence on the TMS pin allows the JTAG module to shift in new instructions, shift in data, or idle during extended testing sequences. For detailed information on the function of the TAP controller and the operations that occur in each state, please refer to *IEEE Standard 1149.1*.

Figure 4-2. Test Access Port State Machine

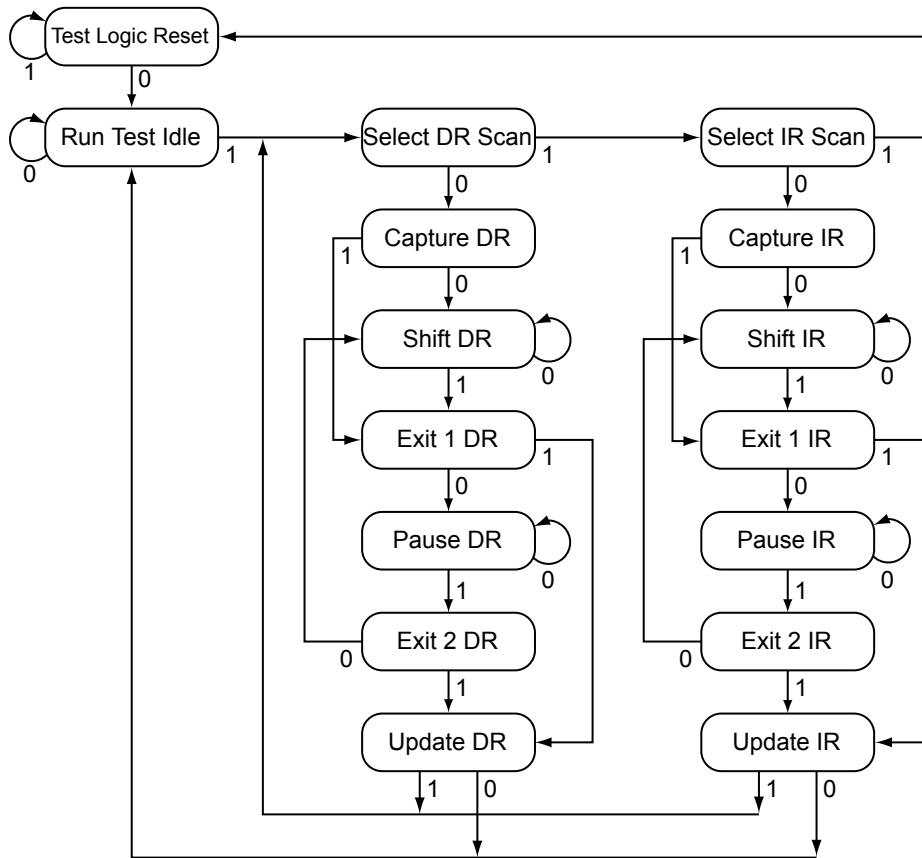

4.3.3 Shift Registers

The Shift Registers consist of a serial shift register chain and a parallel load register. The serial shift register chain samples specific information during the TAP controller's CAPTURE states and allows this information to be shifted out on TDO during the TAP controller's SHIFT states. While the sampled data is being shifted out of the chain on TDO, new data is being shifted into the serial shift register on TDI. This new data is stored in the parallel load register during the TAP controller's UPDATE states. Each of the shift registers is discussed in detail in "Register Descriptions" on page 222.

4.3.4 Operational Considerations

Certain operational parameters must be considered when using the JTAG module. Because the JTAG pins can be programmed to be GPIOs, board configuration and reset conditions on these pins must be considered. In addition, because the JTAG module has integrated ARM Serial Wire Debug, the method for switching between these two operational modes is described below.

4.3.4.1 GPIO Functionality

When the microcontroller is reset with either a POR or $\overline{\text{RST}}$, the JTAG/SWD port pins default to their JTAG/SWD configurations. The default configuration includes enabling digital functionality (DEN[3:0] set in the **Port C GPIO Digital Enable (GPIODEN)** register), enabling the pull-up resistors (PUE[3:0] set in the **Port C GPIO Pull-Up Select (GPIOPUR)** register), disabling the pull-down resistors (PDE[3:0] cleared in the **Port C GPIO Pull-Down Select (GPIOPDR)** register) and enabling the

alternate hardware function ($AFSEL[3:0]$ set in the **Port C GPIO Alternate Function Select (GPIOAFSEL)** register) on the JTAG/SWD pins. See page 778, page 784, page 786, and page 789.

It is possible for software to configure these pins as GPIOs after reset by clearing $AFSEL[3:0]$ in the **Port C GPIOAFSEL** register. If the user does not require the JTAG/SWD port for debugging or board-level testing, this provides four more GPIOs for use in the design.

Caution – It is possible to create a software sequence that prevents the debugger from connecting to the TM4C129ENCPDT microcontroller. If the program code loaded into flash immediately changes the JTAG pins to their GPIO functionality, the debugger may not have enough time to connect and halt the controller before the JTAG pin functionality switches. As a result, the debugger may be locked out of the part. This issue can be avoided with a software routine that restores JTAG functionality based on an external or software trigger. In the case that the software routine is not implemented and the device is locked out of the part, this issue can be solved by using the TM4C129ENCPDT Flash Programmer "Unlock" feature. Please refer to [LMFLASHPROGRAMMER](#) on the TI web for more information.

The GPIO commit control registers provide a layer of protection against accidental programming of critical hardware peripherals. Protection is provided for the GPIO pins that can be used as the four JTAG/SWD pins and the NMI pin (see "Signal Tables" on page 1896 for pin numbers). Writes to protected bits of the **GPIO Alternate Function Select (GPIOAFSEL)** register (see page 778), **GPIO Pull Up Select (GPIOPUR)** register (see page 784), **GPIO Pull-Down Select (GPIOPDR)** register (see page 786), and **GPIO Digital Enable (GPIODEN)** register (see page 789) are not committed to storage unless the **GPIO Lock (GPIOLOCK)** register (see page 791) has been unlocked and the appropriate bits of the **GPIO Commit (GPIOCR)** register (see page 792) have been set.

4.3.4.2 Communication with JTAG/SWD

Because the debug clock and the system clock can be running at different frequencies, care must be taken to maintain reliable communication with the JTAG/SWD interface. In the Capture-DR state, the result of the previous transaction, if any, is returned, together with a 3-bit ACK response. Software should check the ACK response to see if the previous operation has completed before initiating a new transaction. Alternatively, if the system clock is at least 8 times faster than the debug clock (TCK or $SWCLK$), the previous operation has enough time to complete and the ACK bits do not have to be checked.

4.3.4.3 Recovering a "Locked" Microcontroller

Note: Performing the sequence below restores the non-volatile registers discussed in "Non-Volatile Register Programming-- Flash Memory Resident Registers" on page 621 to their factory default values. The mass erase of the Flash memory caused by the sequence below occurs prior to the non-volatile registers being restored.

In addition, the EEPROM is erased and its wear-leveling counters are returned to factory default values when performing the sequence below.

If software configures any of the JTAG/SWD pins as GPIO and loses the ability to communicate with the debugger, there is a debug port unlock sequence that can be used to recover the microcontroller. Performing a total of ten JTAG-to-SWD and SWD-to-JTAG switch sequences while holding the microcontroller in reset mass erases the Flash memory. The debug port unlock sequence is:

1. Assert and hold the \overline{RST} signal.
2. Apply power to the device.

3. Perform steps 1 and 2 of the JTAG-to-SWD switch sequence on the section called “JTAG-to-SWD Switching” on page 221.
4. Perform steps 1 and 2 of the SWD-to-JTAG switch sequence on the section called “SWD-to-JTAG Switching” on page 222.
5. Perform steps 1 and 2 of the JTAG-to-SWD switch sequence.
6. Perform steps 1 and 2 of the SWD-to-JTAG switch sequence.
7. Perform steps 1 and 2 of the JTAG-to-SWD switch sequence.
8. Perform steps 1 and 2 of the SWD-to-JTAG switch sequence.
9. Perform steps 1 and 2 of the JTAG-to-SWD switch sequence.
10. Perform steps 1 and 2 of the SWD-to-JTAG switch sequence.
11. Perform steps 1 and 2 of the JTAG-to-SWD switch sequence.
12. Perform steps 1 and 2 of the SWD-to-JTAG switch sequence.
13. Release the $\overline{\text{RST}}$ signal.
14. Wait 400 ms.
15. Power-cycle the microcontroller.

4.3.4.4 ARM Serial Wire Debug (SWD)

In order to seamlessly integrate the ARM Serial Wire Debug (SWD) functionality, a serial-wire debugger must be able to connect to the Cortex-M4F core without having to perform, or have any knowledge of, JTAG cycles. This integration is accomplished with a SWD preamble that is issued before the SWD session begins.

The switching preamble used to enable the SWD interface of the SWJ-DP module starts with the TAP controller in the Test-Logic-Reset state. From here, the preamble sequences the TAP controller through the following states: Run Test Idle, Select DR, Select IR, Test Logic Reset, Test Logic Reset, Run Test Idle, Run Test Idle, Select DR, Select IR, Test Logic Reset, Test Logic Reset, Run Test Idle, Run Test Idle, Select DR, Select IR, and Test Logic Reset states.

Stepping through this sequence of the TAP state machine enables the SWD interface and disables the JTAG interface. For more information on this operation and the SWD interface, see the *ARM® Debug Interface V5 Architecture Specification*.

Because this sequence is a valid series of JTAG operations that could be issued, the ARM JTAG TAP controller is not fully compliant to the *IEEE Standard 1149.1*. This instance is the only one where the ARM JTAG TAP controller does not meet full compliance with the specification. Due to the low probability of this sequence occurring during normal operation of the TAP controller, it should not affect normal performance of the JTAG interface.

JTAG-to-SWD Switching

To switch the operating mode of the Debug Access Port (DAP) from JTAG to SWD mode, the external debug hardware must send the switching preamble to the microcontroller. The 16-bit TMS/SWDIO command for switching to SWD mode is defined as b1110.0111.1001.1110, transmitted LSB first. This command can also be represented as 0xE79E when transmitted LSB first. The

complete switch sequence should consist of the following transactions on the TCK/SWCLK and TMS/SWDIO signals:

1. Send at least 50 TCK/SWCLK cycles with TMS/SWDIO High to ensure that both JTAG and SWD are in their reset states.
2. Send the 16-bit JTAG-to-SWD switch command, 0xE79E, on TMS/SWDIO.
3. Send at least 50 TCK/SWCLK cycles with TMS/SWDIO High to ensure that if SWJ-DP was already in SWD mode before sending the switch sequence, the SWD goes into the line reset state.

To verify that the Debug Access Port (DAP) has switched to the Serial Wire Debug (SWD) operating mode, perform a SWD READID operation. The ID value can be compared against the device's known ID to verify the switch.

SWD-to-JTAG Switching

To switch the operating mode of the Debug Access Port (DAP) from SWD to JTAG mode, the external debug hardware must send a switch command to the microcontroller. The 16-bit TMS/SWDIO command for switching to JTAG mode is defined as b1110.0111.0011.1100, transmitted LSB first. This command can also be represented as 0xE73C when transmitted LSB first. The complete switch sequence should consist of the following transactions on the TCK/SWCLK and TMS/SWDIO signals:

1. Send at least 50 TCK/SWCLK cycles with TMS/SWDIO High to ensure that both JTAG and SWD are in their reset states.
2. Send the 16-bit SWD-to-JTAG switch command, 0xE73C, on TMS/SWDIO.
3. Send at least 50 TCK/SWCLK cycles with TMS/SWDIO High to ensure that if SWJ-DP was already in JTAG mode before sending the switch sequence, the JTAG goes into the Test Logic Reset state.

To verify that the Debug Access Port (DAP) has switched to the JTAG operating mode, set the JTAG Instruction Register (IR) to the IDCODE instruction and shift out the Data Register (DR). The DR value can be compared against the device's known IDCODE to verify the switch.

4.4 Initialization and Configuration

After a Power-On-Reset or an external reset ($\overline{\text{RST}}$), the JTAG pins are automatically configured for JTAG communication. No user-defined initialization or configuration is needed. However, if the user application changes these pins to their GPIO function, they must be configured back to their JTAG functionality before JTAG communication can be restored. To return the pins to their JTAG functions, enable the four JTAG pins (PC[3:0]) for their alternate function using the **GPIOAFSEL** register. In addition to enabling the alternate functions, any other changes to the GPIO pad configurations on the four JTAG pins (PC[3:0]) should be returned to their default settings.

4.5 Register Descriptions

The registers in the JTAG TAP Controller or Shift Register chains are not memory mapped and are not accessible through the on-chip Advanced Peripheral Bus (APB). Instead, the registers within the JTAG controller are all accessed serially through the TAP Controller. These registers include the Instruction Register and the six Data Registers.

4.5.1 Instruction Register (IR)

The JTAG TAP Instruction Register (IR) is a four-bit serial scan chain connected between the JTAG TDI and TDO pins with a parallel load register. When the TAP Controller is placed in the correct states, bits can be shifted into the IR. Once these bits have been shifted into the chain and updated, they are interpreted as the current instruction. The decode of the IR bits is shown in Table 4-3. A detailed explanation of each instruction, along with its associated Data Register, follows.

Table 4-3. JTAG Instruction Register Commands

IR[3:0]	Instruction	Description
0x0	EXTEST	Drives the values preloaded into the Boundary Scan Chain by the SAMPLE/PRELOAD instruction onto the pads.
0x2	SAMPLE / PRELOAD	Captures the current I/O values and shifts the sampled values out of the Boundary Scan Chain while new preload data is shifted in.
0x8	ABORT	Shifts data into the ARM Debug Port Abort Register.
0xA	DPACC	Shifts data into and out of the ARM DP Access Register.
0xB	APACC	Shifts data into and out of the ARM AC Access Register.
0xE	IDCODE	Loads manufacturing information defined by the <i>IEEE Standard 1149.1</i> into the IDCODE chain and shifts it out.
0xF	BYPASS	Connects TDI to TDO through a single Shift Register chain.
All Others	Reserved	Defaults to the BYPASS instruction to ensure that TDI is always connected to TDO.

4.5.1.1 EXTEST Instruction

The EXTEST instruction is not associated with its own Data Register chain. Instead, the EXTEST instruction uses the data that has been preloaded into the Boundary Scan Data Register using the SAMPLE/PRELOAD instruction. When the EXTEST instruction is present in the Instruction Register, the preloaded data in the Boundary Scan Data Register associated with the outputs and output enables are used to drive the GPIO pads rather than the signals coming from the core. With tests that drive known values out of the controller, this instruction can be used to verify connectivity. While the EXTEST instruction is present in the Instruction Register, the Boundary Scan Data Register can be accessed to sample and shift out the current data and load new data into the Boundary Scan Data Register.

4.5.1.2 SAMPLE/PRELOAD Instruction

The SAMPLE/PRELOAD instruction connects the Boundary Scan Data Register chain between TDI and TDO. This instruction samples the current state of the pad pins for observation and preloads new test data. Each GPIO pad has an associated input, output, and output enable signal. When the TAP controller enters the Capture DR state during this instruction, the input, output, and output-enable signals to each of the GPIO pads are captured. These samples are serially shifted out on TDO while the TAP controller is in the Shift DR state and can be used for observation or comparison in various tests.

While these samples of the inputs, outputs, and output enables are being shifted out of the Boundary Scan Data Register, new data is being shifted into the Boundary Scan Data Register from TDI. Once the new data has been shifted into the Boundary Scan Data Register, the data is saved in the parallel load registers when the TAP controller enters the Update DR state. This update of the parallel load register preloads data into the Boundary Scan Data Register that is associated with each input, output, and output enable. This preloaded data can be used with the EXTEST instruction to drive data into or out of the controller. See “Boundary Scan Data Register” on page 225 for more information.

4.5.1.3 ABORT Instruction

The ABORT instruction connects the associated ABORT Data Register chain between TDI and TDO. This instruction provides read and write access to the ABORT Register of the ARM Debug Access Port (DAP). Shifting the proper data into this Data Register clears various error bits or initiates a DAP abort of a previous request. See the “ABORT Data Register” on page 226 for more information.

4.5.1.4 DPACC Instruction

The DPACC instruction connects the associated DPACC Data Register chain between TDI and TDO. This instruction provides read and write access to the DPACC Register of the ARM Debug Access Port (DAP). Shifting the proper data into this register and reading the data output from this register allows read and write access to the ARM debug and status registers. See “DPACC Data Register” on page 226 for more information.

4.5.1.5 APACC Instruction

The APACC instruction connects the associated APACC Data Register chain between TDI and TDO. This instruction provides read and write access to the APACC Register of the ARM Debug Access Port (DAP). Shifting the proper data into this register and reading the data output from this register allows read and write access to internal components and buses through the Debug Port. See “APACC Data Register” on page 225 for more information.

4.5.1.6 IDCODE Instruction

The IDCODE instruction connects the associated IDCODE Data Register chain between TDI and TDO. This instruction provides information on the manufacturer, part number, and version of the ARM core. This information can be used by testing equipment and debuggers to automatically configure input and output data streams. IDCODE is the default instruction loaded into the JTAG Instruction Register when a Power-On-Reset (POR) is asserted, or the Test-Logic-Reset state is entered. See “IDCODE Data Register” on page 224 for more information.

4.5.1.7 BYPASS Instruction

The BYPASS instruction connects the associated BYPASS Data Register chain between TDI and TDO. This instruction is used to create a minimum length serial path between the TDI and TDO ports. The BYPASS Data Register is a single-bit shift register. This instruction improves test efficiency by allowing components that are not needed for a specific test to be bypassed in the JTAG scan chain by loading them with the BYPASS instruction. See “BYPASS Data Register” on page 225 for more information.

4.5.2 Data Registers

The JTAG module contains six Data Registers. These serial Data Register chains include: IDCODE, BYPASS, Boundary Scan, APACC, DPACC, and ABORT and are discussed in the following sections.

4.5.2.1 IDCODE Data Register

The format for the 32-bit IDCODE Data Register defined by the *IEEE Standard 1149.1* is shown in Figure 4-3. The standard requires that every JTAG-compliant microcontroller implement either the IDCODE instruction or the BYPASS instruction as the default instruction. The LSB of the IDCODE Data Register is defined to be a 1 to distinguish it from the BYPASS instruction, which has an LSB of 0. This definition allows auto-configuration test tools to determine which instruction is the default instruction.

The major uses of the JTAG port are for manufacturer testing of component assembly and program development and debug. To facilitate the use of auto-configuration debug tools, the IDCODE instruction outputs a value of 0x4BA0.0477. This value allows the debuggers to automatically configure themselves to work correctly with the Cortex-M4F during debug.

Figure 4-3. IDCODE Register Format

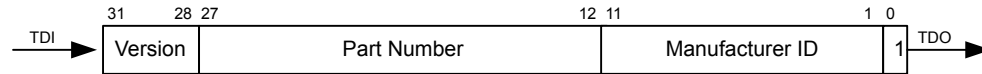

4.5.2.2 BYPASS Data Register

The format for the 1-bit BYPASS Data Register defined by the *IEEE Standard 1149.1* is shown in Figure 4-4. The standard requires that every JTAG-compliant microcontroller implement either the BYPASS instruction or the IDCODE instruction as the default instruction. The LSB of the BYPASS Data Register is defined to be a 0 to distinguish it from the IDCODE instruction, which has an LSB of 1. This definition allows auto-configuration test tools to determine which instruction is the default instruction.

Figure 4-4. BYPASS Register Format

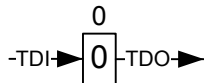

4.5.2.3 Boundary Scan Data Register

The format of the Boundary Scan Data Register is shown in Figure 4-5. Each GPIO pin, starting with a GPIO pin next to the JTAG port pins, is included in the Boundary Scan Data Register. Each GPIO pin has three associated digital signals that are included in the chain. These signals are input, output, and output enable, and are arranged in that order as shown in the figure.

When the Boundary Scan Data Register is accessed with the SAMPLE/PRELOAD instruction, the input, output, and output enable from each digital pad are sampled and then shifted out of the chain to be verified. The sampling of these values occurs on the rising edge of TCK in the Capture DR state of the TAP controller. While the sampled data is being shifted out of the Boundary Scan chain in the Shift DR state of the TAP controller, new data can be preloaded into the chain for use with the EXTEST instruction. The EXTEST instruction forces data out of the controller.

Figure 4-5. Boundary Scan Register Format

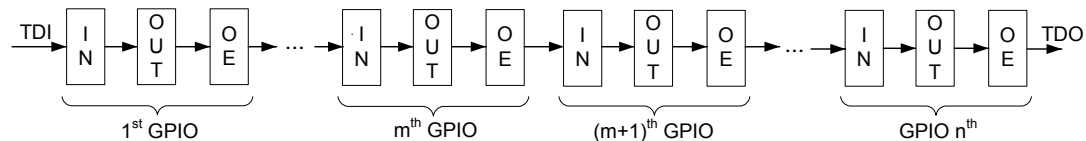

4.5.2.4 APACC Data Register

The format for the 35-bit APACC Data Register defined by ARM is described in the *ARM® Debug Interface V5 Architecture Specification*.

4.5.2.5 DPACC Data Register

The format for the 35-bit DPACC Data Register defined by ARM is described in the *ARM® Debug Interface V5 Architecture Specification*.

4.5.2.6 ABORT Data Register

The format for the 35-bit ABORT Data Register defined by ARM is described in the *ARM® Debug Interface V5 Architecture Specification*.

5 System Control

System control configures the overall operation of the device and provides information about the device. Configurable features include reset control, NMI operation, power control, clock control, and low-power modes.

5.1 Signal Description

The following table lists the external signals of the System Control module and describes the function of each. The NMI signal is the alternate function for two GPIO signals, which default to GPIO after reset. The NMI pins are under commit protection and require a special process to be configured as any alternate function or to subsequently return to the GPIO function. See “Commit Control” on page 760 for more information. The column in the table below titled “Pin Mux/Pin Assignment” lists the GPIO pin placement for the NMI signal. The number in parentheses next to the pin placement listed is the encoding that must be programmed into the PMC_n field in the **GPIO Port Control (GPIOCTL)** register (page 795) to assign the NMI signal to the specified GPIO port pin. In addition, the $AFSEL$ bit in the **GPIO Alternate Function Select (GPIOAFSEL)** register (page 778) should be set to choose the NMI function. For more information on configuring GPIOs, see “General-Purpose Input/Outputs (GPIOs)” on page 750. The remaining signals listed in the table (with the word “fixed” in the Pin Mux/Pin Assignment column) have a fixed pin assignment and function.

Table 5-1. System Control & Clocks Signals (128TQFP)

Pin Name	Pin Number	Pin Mux / Pin Assignment	Pin Type	Buffer Type	Description
DIVSCLK	102	PQ4 (7)	O	TTL	An optionally divided reference clock output based on a selected clock source. Note that this signal is not synchronized to the System Clock.
NMI	128	PD7 (8)	I	TTL	Non-maskable interrupt.
OSC0	88	fixed	I	Analog	Main oscillator crystal input or an external clock reference input.
OSC1	89	fixed	O	Analog	Main oscillator crystal output. Leave unconnected when using a single-ended clock source.
RST	70	fixed	I	TTL	System reset input.

5.2 Functional Description

The System Control module provides the following capabilities:

- Device identification, see “Device Identification” on page 227
- Configurable control of reset, power, and clock sources.
- System control (Run, Sleep, and Deep-Sleep modes), see “System Control” on page 246

5.2.1 Device Identification

Read-only registers in the system control module provide information about the microcontroller, such as version, part number, pin count, operating temperature range and available peripherals on the device. The **Device Identification 0 (DID0)** (page 262) and **Device Identification 1 (DID1)** (page 264) registers provide details about the device's version, package, temperature range, and so on. The Peripheral Present registers starting at system control offset 0x300, such as the **Watchdog**

Timer Peripheral Present (PPWD) register, provide information on how many of each type of module are included on the device. Finally, information about the capabilities of the on-chip peripherals are provided at offset 0xFC0 in each peripheral's register space in the Peripheral Properties registers, such as the **GPTM Peripheral Properties (GPTMPP)**. In addition, there are four unique identifier registers, **Unique Identifier n (UNIQUEIDn)**, that provide a 128-bit unique identifier for each device that cannot be modified.

5.2.2 Reset Control

This section discusses aspects of hardware functions during reset as well as system software requirements following the reset sequence.

5.2.2.1 Reset Sources

The TM4C129ENC PDT microcontroller has the following reset sources:

1. Power-on reset (POR) (see page 229).
2. External reset input pin (\overline{RST}) assertion (see page 230).
3. A brown-out detection of V_{DDA} (analog voltage source) or V_{DD} (external voltage source) dropping below its acceptable operating range. (see page 231).
4. Software-initiated reset (with the software reset registers) (see page 233).
5. A watchdog timer reset condition violation (see page 233).
6. Hibernation module event
7. A software restart initiated through a Hardware System Service Request (HSSR)
8. MOSC failure (see page 235).

Table 5-2 provides a summary of results of the various reset operations. Note that the external \overline{RST} pin, the Brown-out detection unit, the HIB module and watchdog timer can all be programmed to generate either a Power-On Reset (POR) or system reset depending on how the **Reset Behavior Control (RESBEHAVCTL)** register at offset 0x1D8 is programmed.

Table 5-2. Reset Sources

Reset Source	Core Reset?	JTAG Reset?	On-Chip Peripherals Reset?
Externally Generated Power-On Reset	Yes	Yes	Yes
\overline{RST} pin Power-On Reset	Yes	Pin Configuration Only	Yes
\overline{RST} pin System Reset	Yes	Pin Configuration Only	Yes
Brown-Out Power-On Reset	Yes	Pin Configuration Only	Yes
Brown-Out System Reset	Yes	Pin Configuration Only	Yes
Software System Reset Request using the <code>SYSRESREQ</code> bit in the APINT register.	Yes	Pin Configuration Only	Yes
Software System Reset Request using the <code>VECTRESET</code> bit in the APINT register.	Yes	No	No

Table 5-2. Reset Sources (continued)

Reset Source	Core Reset?	JTAG Reset?	On-Chip Peripherals Reset?
Software Peripheral Reset	No	Pin Configuration Only	Yes ^a
Watchdog Power-On Reset	Yes	Pin Configuration Only	Yes
Watchdog System Reset	Yes	Pin Configuration Only	Yes
HIB Module Power-On Reset	Yes	Pin Configuration Only	Yes
HIB Module System Reset	Yes	Pin Configuration Only	Yes
HSSR Reset	Yes	Pin Configuration Only	Yes
MOSC Failure Reset	Yes	Pin Configuration Only	Yes

a. Programmable on a module-by-module basis by using the individual peripheral Software Reset Registers starting at System Control offset 0x500

After a reset, the **Reset Cause (RESC)** register is set with the reset cause. The bits in this register are sticky and maintain their state across multiple reset sequences. A bit in the **RESC** register can be cleared by writing a 0.

5.2.2.2 Boot Configuration

After Power-On-Reset (POR) and device initialization occurs, the hardware loads the stack pointer from either flash or ROM based on the presence of an application in flash and the state of the **EN** bit in the **BOOTCFG** register. If the flash address 0x0000.0004 contains an erased word (value 0xFFFF.FFFF) or the **EN** bit is of the **BOOTCFG** register is clear, the stack pointer and reset vector pointer are loaded from ROM at address 0x0100.0000 and 0x0100.0004, respectively. The boot loader executes and configures the available boot slave interfaces and waits for an external memory to load its software.

If the check of the Flash at address 0x0000.0004 contains a valid reset vector value and the **BOOTCFG** register does not indicate the boot loader, the boot sequence causes the stack pointer/reset vector fetch from Flash. This application stack pointer and reset vector is loaded and the processor executes the application directly.

Note: If the device fails the initialization phase, it toggles the **TDO** output pin as an indication the device is not executing. This feature is provided for debug purposes.

5.2.2.3 Externally Generated Power-On Reset (POR)

Note: The JTAG controller can be reset by a power-on reset or by holding the **TMS** pin to high for 5 clock cycles.

During an externally generated POR, the internal Power-On Reset (POR) circuit monitors the power supply voltage (V_{DD}) and generates a reset signal to all of the internal logic including JTAG when the power supply ramp reaches a threshold value (V_{POR}). Reset does not complete if specific voltage parameters are not met as defined in the Electrical Characteristics chapter. For applications that require the use of an external reset signal to hold the microcontroller in reset longer than the internal POR, the \overline{RST} input may be used as discussed in “External \overline{RST} Pin” on page 230. Holding this pin active can keep the initialization process from starting even though power-on reset has occurred. This is useful in in-circuit testing and other situations where it is desirable to delay the operation of the device until an external supervisor has released.

The Power-On Reset sequence is as follows:

1. The microcontroller waits for internal POR to go inactive.

2. The internal reset is released and the core executes a full initialization of the device. Upon completion, the core loads from memory the initial stack pointer, the initial program counter, and the first instruction designated by the program counter, and then begins execution.

The internal POR is only active on the initial power-up of the microcontroller, when the microcontroller wakes from hibernation, and when the VDD supply drops below the its defined operating limit. Please refer to the Electrical Characteristics chapter for information on exact values. The Power-On Reset timing is shown in “Power and Brown-Out” on page 1950.

5.2.2.4 External $\overline{\text{RST}}$ Pin

When the external $\overline{\text{RST}}$ pin is asserted it initiates a system reset or Power-On Reset depending on what has been configured in the **Reset Behavior Control (RESBEHAVCTL)** Register. If the **EXTRES** bit field in **RESBEHAVCTL** is set to 0x3 then a simulated full initialization will begin upon $\overline{\text{RST}}$ assertion. If these bits are programmed to 0x2 then a system reset is issued. When **EXTRES** is set to a 0x0 or 0x1, then the external $\overline{\text{RST}}$ pin performs its default operation upon assertion, which is issuing a full simulated POR.

An external reset pin ($\overline{\text{RST}}$) that is configured to generate a Power-On Reset resets the microcontroller including the core and all the on-chip peripherals. The external reset sequence is as follows:

1. The external reset pin ($\overline{\text{RST}}$) is asserted for the duration specified by T_{MIN} and then deasserted (see “Reset” on page 1955). This generates an internal POR signal.
2. The microcontroller waits for internal POR to go inactive.
3. The internal reset is released and the core executes a full initialization of the device. Upon completion, the core loads from memory the initial stack pointer, the initial program counter, and the first instruction designated by the program counter, and then begins execution. Refer to “Reset” on page 1955 for internal reset deassertion timing.

An external reset pin ($\overline{\text{RST}}$) that is configured to generate a system reset will reset the microcontroller including the core and all the on-chip peripherals. The external reset sequence is as follows:

1. The external reset pin ($\overline{\text{RST}}$) is asserted for the duration specified by T_{MIN} and then deasserted (see “Reset” on page 1955).
2. The internal reset is released and the core loads from memory the initial stack pointer, the initial program counter, and the first instruction designated by the program counter, and then begins execution.

Note: It is recommended that the trace for the $\overline{\text{RST}}$ signal must be kept as short as possible. Be sure to place any components connected to the $\overline{\text{RST}}$ signal as close to the microcontroller as possible.

If the application only uses the internal POR circuit, the $\overline{\text{RST}}$ input must be connected to the power supply (V_{DD}) through an optional pull-up resistor (0 to 100K Ω) as shown in Figure 5-1 on page 231. The $\overline{\text{RST}}$ input has filtering which requires a minimum pulse width in order for the reset pulse to be recognized, see Table 30-14 on page 1955.

To improve noise immunity and/or to delay reset at power up, the $\overline{\text{RST}}$ input may be connected to an RC network as shown in Figure 5-2 on page 231. If the application requires the use of an external reset switch, Figure 5-3 on page 231 shows the proper circuitry to use. In the figures, the R_{PU} and C_1 components define the power-on delay. The external reset timing is shown in Figure 30-11 on page 1956.

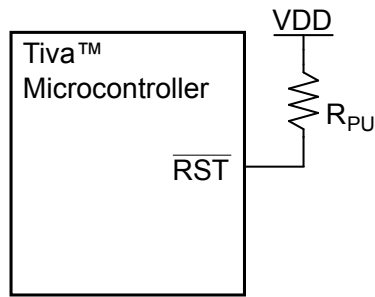
Figure 5-1. Basic $\overline{\text{RST}}$ Configuration

Note: $R_{PU} = 0$ to 100 k Ω

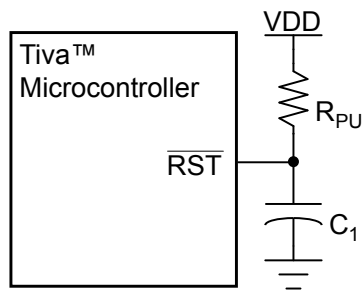
Figure 5-2. External Circuitry to Extend Power-On Reset

Note: $R_{PU} = 1$ k Ω to 100 k Ω

$C_1 = 1$ nF to 10 μ F

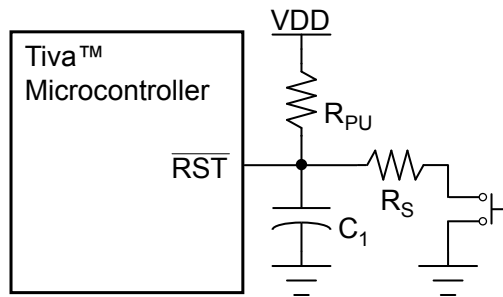
Figure 5-3. Reset Circuit Controlled by Switch

Note: Typical $R_{PU} = 10$ k Ω

Typical $R_S = 470$ Ω

$C_1 = 10$ nF

5.2.2.5 Brown-Out Reset (BOR)

The microcontroller provides a brown-out detection circuit that triggers if the V_{DD} (external) or V_{DDA} (analog) power supply drops below its corresponding brown-out threshold voltage. If a brown-out condition is detected, the system may generate an interrupt, a system reset or a Power-On Reset. The default value at reset is to generate an interrupt.

The application can identify the type of BOR event that occurred by reading the **Power-Temperature Cause (PWRTC)** register. The BOR detection circuits can be programmed to generate a reset, System Control interrupt, or NMI in the **Power-Temp Brown Out Control (PTBOCTL)** register. The default settings at reset are as follows:

- V_{DDA} under BOR detection default setting is for no action to occur.
- V_{DD} under BOR detection default setting is to execute a full POR.

If the user has programmed a field in the **PTBOCTL** to generate a reset, then the `BOR` bit of the **Reset Behavior Control (RESBEHAVCTL)** register can be programmed to further define what type of reset is generated. If the `BOR` field is programmed to 0x3, a full POR is initiated; if is set to 0x2, then a system reset is issued. When the `BOR` field is set to a 0x0 or 0x1, then the Brown-Out detection circuit will perform its default operation upon assertion, which is issuing an interrupt.

Note: V_{DDA} BOR and V_{DD} BOR events are a combined BOR to the system logic, such that if either BOR event occurs, the following bits are affected:

- `BORRIS` bit in the **Raw Interrupt Status (RIS)** register, System Control offset 0x050. See page 268.
- `BORMIS` bit in the **Masked Interrupt Status and Clear (MISC)** register, System Control offset 0x058. This bit is set only if the `BORIM` bit in the **Interrupt Mask Control (IMC)** register has been set. See page 270 and page 272.
- `BOR` bit in the **Reset Cause (RESC)** register, System Control offset 0x05C. This bit is set only if either of the BOR events have been configured to initiate a reset. See page 274.

In addition, the following bits control both BOR events:

- `BORIM` bit in the **Interrupt Mask Control (IMC)** register, System Control offset 0x054.
- `VDDA_UBOR0` and `VDD_UBOR0` bits in the **Power-Temperature Cause (PWRTC)** register.

Please refer to “System Control” on page 227 for more information on how to configure these registers.

The brown-out POR reset sequence is as follows:

1. When one of the BOR event triggers occurs, an internal Brown-Out Reset condition is set.
2. If the BOR event has been programmed to generate a reset in the **PTBOCTL** register and the `BOR` bit of the **RESBEHAVCTL** has been set to 0x3, an internal POR reset is asserted.
3. The internal reset is released and the core executes a full initialization of the device. Upon completion, the core loads from memory the initial stack pointer, the initial program counter, and the first instruction designated by the program counter, and then begins execution. The application starts after deassertion of internal POR. Refer to “Reset” on page 1955 for BOR internal reset deassertion timing.

The brown-out system reset sequence is as follows:

1. When one of the BOR event triggers occurs, an internal Brown-Out Reset condition is set.
2. If the BOR event has been programmed to generate a reset in the **PTBOCTL** register and the `BOR` bit of the **RESBEHAVCTL** has been set to 0x2, an internal reset is asserted.

3. The internal reset is released and the microcontroller fetches and loads the initial stack pointer, the initial program counter, the first instruction designated by the program counter, and begins execution.

The result of a brown-out reset is equivalent to that of an assertion of the external $\overline{\text{RST}}$ input, and the reset is held active until the proper voltage level is restored. The **RESC** register can be examined in the reset interrupt handler to determine if a Brown-Out condition was the cause of the reset, thus allowing software to determine what actions are required to recover.

The internal Brown-Out Reset timing is shown in “Power and Brown-Out” on page 1950.

5.2.2.6 Software Reset

Software can reset a specific peripheral or generate a reset to the entire microcontroller.

Peripherals can be individually reset by software via peripheral-specific reset registers available beginning at System Control offset 0x500 (for example the **Watchdog Timer Software Reset (SRWD)** register page 361). If the bit position corresponding to a peripheral is set and subsequently cleared, the peripheral is reset.

The entire microcontroller, including the core, can be reset by software by setting the **SYSRESREQ** bit in the **Application Interrupt and Reset Control (APINT)** register in the core peripheral memory map space. The software-initiated system reset sequence is as follows:

1. A software microcontroller reset is initiated by setting the **SYSRESREQ** bit.
2. An internal reset is asserted.
3. The internal reset is deasserted and the microcontroller loads from memory the initial stack pointer, the initial program counter, and the first instruction designated by the program counter, and then begins execution.

The core only can be reset by software by setting the **VECTRESET** bit in the **APINT** register. The software-initiated core reset sequence is as follows:

1. A core reset is initiated by setting the **VECTRESET** bit.
2. An internal reset is asserted.
3. The internal reset is deasserted and the microcontroller loads from memory the initial stack pointer, the initial program counter, and the first instruction designated by the program counter, and then begins execution.

The software-initiated system reset timing is shown in Figure 30-12 on page 1956.

5.2.2.7 Watchdog Timer Reset

The Watchdog Timer module's function is to prevent system hangs. The TM4C129ENC PDT microcontroller has two Watchdog Timer modules in case one watchdog clock source fails. One watchdog is run off the system clock and the other is run off the Precision Internal Oscillator (PIOSC). The watchdog timer can be configured to generate an interrupt or a non-maskable interrupt to the microcontroller on its first time-out and to generate a system reset or power-on reset on its second time-out.

After the watchdog's first time-out event, the 32-bit watchdog counter is reloaded with the value of the **Watchdog Timer Load (WDTLOAD)** register and resumes counting down from that value. If the timer counts down to zero again before the first time-out interrupt is cleared, and watchdog reset

generation has been enabled through the `RESEN` bit in the **Watchdog Control Register (WDTCTL)**, the watchdog timer asserts its reset signal to the microcontroller. The reset generated can be a full Power-On Reset or a system reset depending on the value programmed in `WDOGn` bit field of the **Reset Behavior Control Register (RESBEHAVCTL)**. If the `RESEN` bit of the **WDTCTL** register is set to 1 and the `WDOGn` bit field of the **RESBEHAVCTL** register is programmed to 0x3 a full POR is initiated; if `WDOGn` set to 0x2, then a system reset is issued. When `WDOGn` is set to a 0x0 or 0x1, then the watchdog time performs its default operation upon assertion, which is issuing a full POR.

The watchdog timer Power-On Reset sequence is as follows:

1. The watchdog timer times out for the second time without being serviced.
2. An internal POR reset is asserted.
3. The internal reset is released and the core executes a full initialization of the device. Upon completion, the core loads from memory the initial stack pointer, the initial program counter, and the first instruction designated by the program counter, and then begins execution. Refer to “Reset” on page 1955 for watchdog timeout internal reset deassertion timing.

The watch dog timer system reset sequence is as follows:

1. The watchdog timer times out for the second time without being serviced.
2. An internal reset is asserted.
3. The internal reset is released and the microcontroller loads from memory the initial stack pointer, the initial program counter, and the first instruction designated by the program counter, and then begins execution.

For more information on the Watchdog Timer module, see “Watchdog Timers” on page 1152.

The watchdog reset timing is shown in Figure 30-13 on page 1956.

5.2.2.8 Hibernation Module Reset

When the Hibernation module has been configured and powered by an initial "cold" POR and is subsequently put into hibernation mode, a wake event (not including an external reset pin wake) causes the module to generate a system reset. This reset signal resets all circuitry on the device with the exception of the Hibernation module. All Hibernation module registers retain their values after this reset.

When the Hibernation module receives a wake event and V_{DD} is enabled, a system reset sequence occurs as follows:

1. The `POR` or `EXT` bit in the **RESC** register is set.
2. An internal reset is asserted.
3. The internal reset is released and the microcontroller loads from memory the initial stack pointer, the initial program counter, and the first instruction designated by the program counter, and then begins execution.
4. The **HIBRIS** register in the Hibernation module can be read to determine the cause of the reset.
5. The `POR` or `EXT` bit in the **RESC** register is cleared by writing a 0.

5.2.2.9 HSSR Reset

The **Hardware System Service Request (HSSR)** register can be used to restore the device back to factory settings. A successful write to the **Hardware System Service Request (HSSR)** register initiates a system reset. The reset initialization process executes before examining the **HSSR** register and processing the command. This register can only be accessed in privileged mode.

Before the return-to-factory settings routine has completed, a system reset sequence executes and the **HSSR** bit in the **RESC** register is set. After the HSSR function has been processed, the **CDOFF** field in the **HSSR** register is written with the outcome of the function processing and another HSSR system reset is executed. The **HSSR** bit can be cleared in the **RESC** register by writing a 0.

For more information regarding use of the **HSSR** register, refer to “Hardware System Service Request” on page 252.

5.2.3 Non-Maskable Interrupt

The microcontroller has multiple sources of non-maskable interrupt (NMI):

- The assertion of the **NMI** signal.
- A main oscillator verification error.
- The **NMISSET** bit in the **Interrupt Control and State (INTCTRL)** register in the Cortex™-M4F (see page 174).
- The Watchdog module time-out interrupt when the **INTTYPE** bit in the **Watchdog Control (WDTCTL)** register is set (see page 1158).
- Tamper event (see “Hibernation Module” on page 539 for more information).
- Any of the following BOR trigger events:
 - V_{DDA} under BOR setting
 - V_{DD} under BOR setting

Software must check the cause of the interrupt in the **NMI Cause (NMIC)** register in order to distinguish among the sources.

5.2.3.1 NMI Pin

The NMI signal is an alternate function for the GPIO port pin(s) specified in Table 29-3 on page 1909.

The alternate function must be enabled in the GPIO for the signal to be used as an interrupt, as described in “General-Purpose Input/Outputs (GPIOs)” on page 750. Note that enabling the NMI alternate function requires the use of the GPIO lock and commit function, similar to the requirements of the GPIO port pins associated with JTAG/SWD functionality, see page 792. The active sense of the **NMI** signal is High; asserting the enabled **NMI** signal above V_{IH} initiates the NMI interrupt sequence.

5.2.3.2 Main Oscillator Verification Failure

The TM4C129ENCPDT microcontroller provides a main oscillator verification circuit that generates an error condition if the oscillator is running too fast or too slow. If the main oscillator verification circuit is enabled and a failure occurs, either a power-on reset is generated and control is transferred to the NMI handler, or an interrupt is generated. The **MOSCIM** bit in the **MOSCCTL** register determines

which action occurs. In either case, the system clock source is automatically switched to the PIOSC. If a MOSC failure reset occurs, the NMI handler is used to address the main oscillator verification failure because the necessary code can be removed from the general reset handler, speeding up reset processing. The detection circuit is enabled by setting the `CVAL` bit in the **Main Oscillator Control (MOSCCTL)** register. The main oscillator verification error is indicated in the main oscillator fail status (`MOSCFAIL`) bit in the **Reset Cause (RESC)** register. The main oscillator verification circuit action is described in more detail in the section called “Main Oscillator Verification Circuit” on page 243.

5.2.4 Power Control

The TM4C129ENCPDT microcontroller provides an integrated LDO regulator that is used to provide power to the majority of the microcontroller's internal logic. Figure 5-4 shows the power architecture. The voltage output has a maximum voltage of 1.2 V. Refer to “Dynamic Power Management” on page 249 for more information on the LDO operation.

An external LDO may not be used.

Note: V_{DDA} must be supplied with 3.3 V, or the microcontroller does not function properly. V_{DDA} is the supply for all of the analog circuitry on the device, including the clock circuitry.

Figure 5-4. Power Architecture

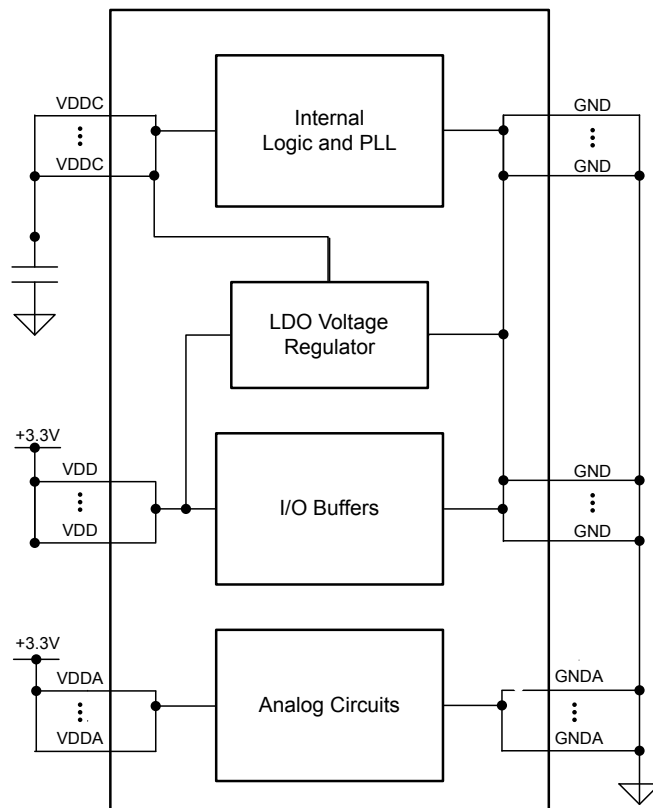

Note: The V_{DDA} voltage source is typically connected to a filtered voltage source or regulator.

5.2.5 Clock Control

The system control module determines the control of clocks in this part.

5.2.5.1 Fundamental Clock Sources

There are multiple clock sources for use in the microcontroller. The **Run and Sleep Mode Configuration Register (RSCLKCFG)** can be used to configure the required clock source for the device after Power-On Reset, as well as the system clock divisor encodings. The available clock sources are as follows:

- **Precision Internal Oscillator (PIOSC).** The precision internal oscillator is an on-chip clock source that the microcontroller uses during and following POR. It is the clock source in effect at the start of reset vector fetch and the start of code application execution. It does not require the use of any external components and provides a clock that is $16\text{ MHz} \pm F_{\text{PIOSC}}$ across temperature (see Table 30-19 on page 1961). The PIOSC allows for a reduced system cost in applications that require an accurate enough clock source. If the main oscillator is required, software must enable the main oscillator following reset and allow the main oscillator to stabilize before changing the clock reference. If the Hibernation Module clock source is a 32.768-kHz oscillator, the precision internal oscillator can be trimmed by software based on a reference clock for increased accuracy. Regardless of whether or not the PIOSC is the source for the system clock, the PIOSC can be configured to be an alternate clock source for some of the peripherals. See the section called “Peripheral Clock Sources” on page 241 for more information on peripherals that can use the PIOSC as an alternate clock.
- **Main Oscillator (MOSC).** The main oscillator provides a frequency-accurate clock source by one of two means: an external single-ended clock source is connected to the OSC0 input pin, or an external crystal is connected across the OSC0 input and OSC1 output pins. If the PLL is being used, the crystal value can be any frequency between 5 MHz to 25 MHz (inclusive). Refer to Table 5-7 on page 245 for recommended crystal values and PLL register programming. If the PLL is not being used, the crystal may be any one of the supported frequencies between 4 MHz to 25 MHz. The single-ended clock source range is from DC through the specified speed of the microcontroller.
- **Low-Frequency Internal Oscillator (LFIOSC).** The Low-Frequency Internal Oscillator (LFIOSC) provides a nominal frequency of 33 kHz with percentage variance specified in the Electrical Characteristics section. It is intended for use during Deep-Sleep power-saving modes. This power-savings mode provides reduced internal switching and the ability to power down the MOSC and/or PIOSC while in Deep-Sleep mode through configuration of the **Deep Sleep Clock Configuration Register (DSCLKCFG)** register.
- **Hibernation Module RTC Oscillator (RTCOSC) Clock Source.** The Hibernation Module provides a muxed output of two clocks to the System Control Module, an external 32.768-kHz clock or a low-frequency clock (HIB LFIOSC). The Hibernation module has the option of being clocked by a 32.768-kHz oscillator connected to the XOSC0 pin. The 32.768-kHz oscillator can be used for the system clock, thus eliminating the need for an additional crystal or oscillator. Alternatively, the Hibernation module contains a low-frequency oscillator (HIB LFIOSC) which is intended to provide the system with a real-time clock source and may also provide an accurate source of Deep-Sleep or Hibernate mode power savings. Note that the HIB LFIOSC is a different clock source than the LFIOSC. Refer to the Electrical Characteristic Chapter for more information on frequency range.

The internal system clock (SysClk), is derived from any of the above sources. An internal PLL can also be used by the PIOSC or MOSC clock to generate the system clock and peripheral clocks. Table 5-3 on page 238 shows how the various clock sources can be used in a system.

Table 5-3. Clock Source Options

Clock Source	Drive PLL Capability?	PLL Enabled, RSCLKCFG Bit Encodings	SysClk generation capability?	SysClk generation enabled, RSCLKCFG Bit Encodings
Precision Internal Oscillator (PIOSC)	Yes	USEPLL = 1, PLLSRC = 0x0	Yes	USEPLL = 0, OSCSRC = 0x0
Main Oscillator (MOSC)	Yes	USEPLL = 1, PLLSRC = 0x3	Yes	USEPLL = 0, OSCSRC = 0x3
Low Frequency Internal Oscillator (LFIOSC) ^a	No	-	Yes	USEPLL = 0, OSCSRC = 0x2
Hibernation Module RTC Oscillator (RTCOSC). 32.768-kHz Oscillator or HIB LFIOSC	No	-	Yes	USEPLL = 0, OSCSRC = 0x4

a. LFIOSC frequency is characterized as 33 kHz nominal, 10 kHz minimum and 90 kHz maximum.

5.2.5.2 Clock Configuration

The **Run and Sleep Mode Configuration Register (RSCLKCFG)** provides control for the system clock in run and sleep mode. The **Deep Sleep Clock Configuration register (DSCLKCFG)** specifies the behavior of the clock system while in deep sleep mode. These registers control the following clock functionality:

- Source of system clock in run and sleep mode
- Source of system clock in deep-sleep mode
- Enabling/disabling of PLL-derived system clock
- Clock divisors for PLL or oscillator, depending on what is enabled
- Enabling of memory timing parameters for flash

Providing further configuration, the **PLL Frequency n (PLLREQn)** registers allow the PLL VCO frequency (f_{VCO}) to multiplied or divided by programmable values depending on the system clock speed required.

Table 5-4 on page 238 shows the state of the clock sources following a Power-On Reset.

Table 5-4. Clock Source State Following POR

Clock Source	Power-On Reset State
PLL	Disabled/Powered Off
MOSC	Disabled/Powered Off
LFIOSC	Enabled
PIOSC	Enabled
HIB RTCOSC	Disabled

Figure 5-5 shows the logic for the main clock tree. The peripheral blocks are driven by the system clock signal and can be individually enabled/disabled.

Note: The clock sources in Figure 5-5 include a superset of peripherals available in the family. Some peripheral clock sources may not be present on your specific device.

Figure 5-5. Main Clock Tree

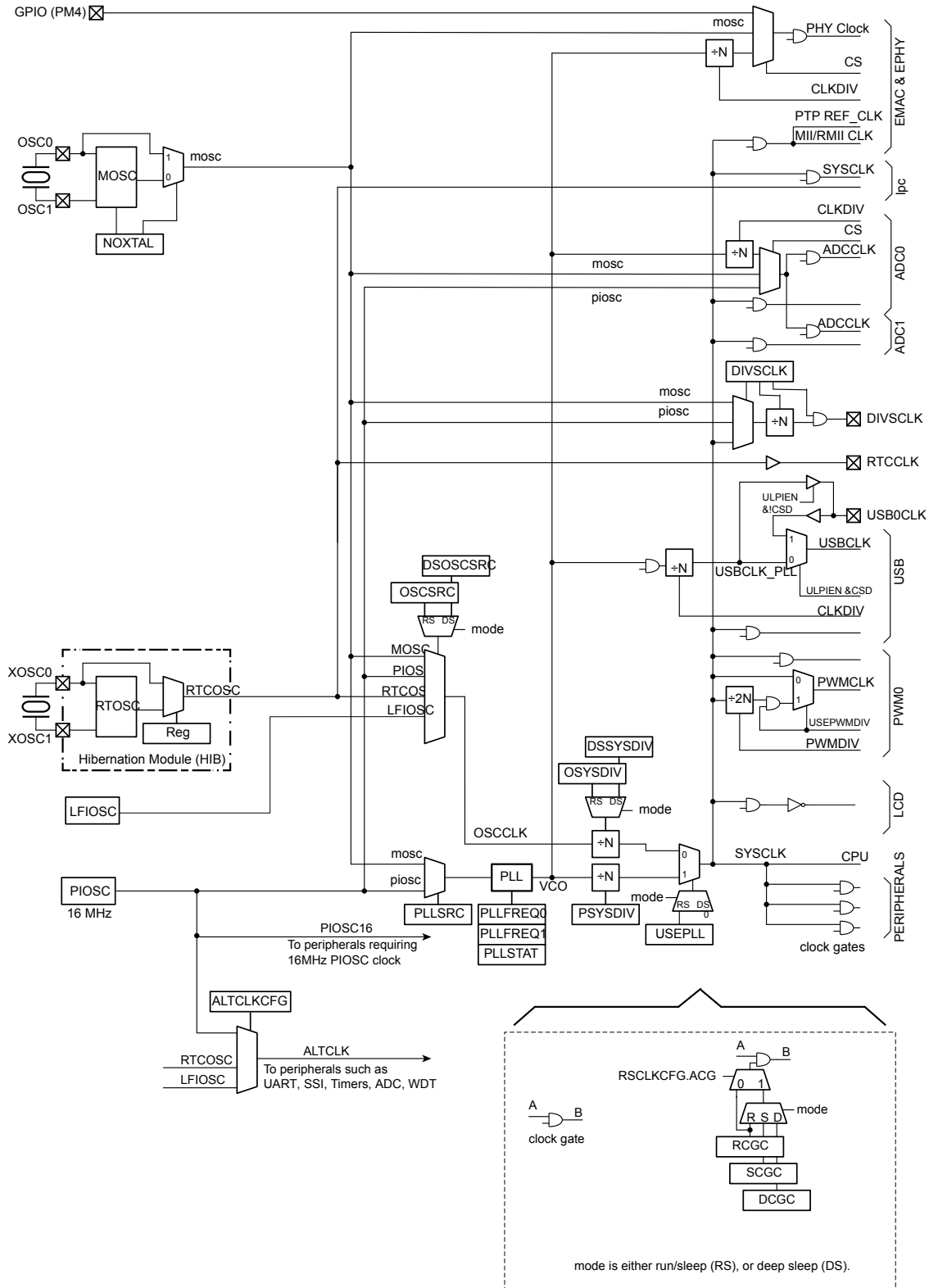

Peripheral Clock Sources

In addition to the main clock tree described above, the ADC, USB, Ethernet, PWM, UART, and QSSI all have a Clock Control register in their register map at offset 0xFC8 that can be used to control the clock generation for the module.

ADC Clock Control

The ADC digital block is clocked by the system clock and the ADC analog block is clocked from a separate conversion clock (ADC clock). The ADC clock frequency can be up to 32 MHz to generate a conversion rate of 2 Msps. A 16 MHz ADC clock provides a 1 Msps sampling rate. There are three sources for the ADC clock:

- The PLL VCO (f_{VCO}) can be used if the `CS` bit field is 0x0 in the **ADC Clock Configuration (ADCCC)** register and the `CLKDIV` bit field is configured in the same register.
- The PIOSC can be used directly to provide a conversion rate near 1 Ms/s. To use the PIOSC, the `CS` field in the **ADCCC** register needs to be set to 0x1 and the `ALTCLK` field should be programmed to 0x0 in the **Alternate Clock Configuration (ALTCLKCFG)** register.
- The Main Oscillator (MOSC): The MOSC clock source must be 16 MHz for a 1 Msps conversion rate and 32 MHz for a 2 Msps conversion rate.

Note: If the ADC module is not using the PIOSC as the clock source, the system clock must be at least 16 MHz.

USB Clock Control

When the USB module uses the integrated USB PHY, the MOSC must be the clock source, either with or without using the PLL, and the system clock must be at least 30 MHz. In addition, only integer divisors should be used to achieve the 60 MHz USB clock source. Fractional divisors may increase jitter and compromise USB function. The **USB Clock Control Register (USBCC)** register contains a `CLKDIV` bit field which can be programmed to specify the divisor used to reduce the PLL VCO output to the 60 MHz clock source required for the serialization/deserialization module of the USB controller.

In ULPI mode, if the clock source to the USB is internal, then the `USB0CLK` pin is an output to the external ULPI PHY. If the USB clock source is external then, the `USB0CLK` pin functions as an input from the external ULPI PHY.

Ethernet Clock Control

The Ethernet Controller Module and Integrated PHY receive two clock inputs. A gated system clock acts as the clock source to the Control and Status registers (CSR) of the Ethernet MAC and must be 20 MHz or greater for correct operation. The `SYSClk` frequency for Run, Sleep and Deep Sleep mode is programmed in the System Control module. See “Ethernet Clock Control” on page 1533 for more information.

PHY Interface Clocking

The Ethernet Controller Module and Integrated PHY receive two clock inputs (see “PHY Interface” on page 1533 for more information):

- A gated system clock acts as the clock source to the Control and Status registers (CSR) of the Ethernet MAC. The `SysClk` frequency for Run, Sleep and Deep Sleep mode is programmed in the System Control module.

- The PHY receives the main oscillator (MOSC) which must be 25 MHz \pm 50 ppm for proper operation. The MOSC source can be a single-ended source or a crystal.

PWM Clock Control

The **PWMCC** register can be used to select the System Clock as the PWM clock source or a divided System Clock. For more information, see page 1871.

Other Peripheral Clock Control

In the UART and QSSI Clock Control Registers, users can choose between the system clock (SysClk), which is the default source for the baud clock, and an alternate clock. Note that there may be special considerations when configuring the baud clock.

Optional Clock Output Signal (DIVSCLK)

An optional clock output, **DIVSCLK**, is provided which can be used as a clock source to an external device but bears no timing relationship to other signals. Note that this signal is not synchronized to the System Clock. By programming the **SRC** field in the **Divisor and Source Clock Configuration (DIVSCLK)** register, the following clock outputs may be selected for **DIVSCLK**:

- System Clock
- PIOSC
- MOSC

The **DIV** field in the **DIVSCLK** register controls the divided output clock frequency. The **DIVSCLK** signal is selected as an alternate function of a GPIO signal and has the same inherit electrical characteristics of a GPIO as listed in “Electrical Characteristics” on page 1942.

System Clock Frequency

The system clock (SysClk) is the clock that is distributed to the processor and the integrated peripherals after clock gating. The SysClk frequency is based on the frequency of the clock source and the divisor factor. For example, if the PLL is not being used and the device is not in deep sleep mode, then the **OSYSYSDIV** bit field in the **RSCLKCFG** register is the divisor used to determine the system clock. If the PLL is being used, then **PSYSYSDIV** bit field in the **RSCLKCFG** register must be programmed as well as the values in the **PLLREQ0** and **PLLREQ1** registers. If the device is in deep sleep mode, then the **Deep Sleep Clock Configuration Register (DSCLKCFG)** can be programmed with the divisor bit field **DSSYSYSDIV** to modify the clock source frequency. Table 5-5 on page 242 shows the different system clock frequency calculations based on the operation mode, clock source and PLL encoding.

Table 5-5. System Clock Frequency

Clock Mode	USEPLL (RSCLKCFG)	SYSCLK Value	Divisor Factors Used
Run or Sleep	1	$f_{VCO} / (PSYSYSDIV + 1)$	PSYSYSDIV bit field in RSCLKCFG ; MINT, MDIV in PLLREQ0 ; Q, N bits in PLLREQ1
Run or Sleep	0	$f_{OSCLK} / (OSYSYSDIV + 1)$	OSYSYSDIV bit field in RSCLKCFG
Deep Sleep	PLL not enabled in Deep Sleep	$f_{OSCLK} / (DSSYSYSDIV + 1)$	DSSYSYSDIV bit field in DSCLKCFG

5.2.5.3 Precision Internal Oscillator Operation (PIOSC)

The microcontroller powers up with the PIOSC running. If another clock source is desired, the PIOSC must remain enabled because it is used for internal functions. The PIOSC can only be disabled during Deep-Sleep mode. It can be powered down by setting the `PIOSCPD` bit in the **DSCLKCFG** register.

The PIOSC generates a 16-MHz clock with a $\pm F_{PIOSC}$ accuracy (see Table 30-19 on page 1961). At the factory, the PIOSC is set to 16 MHz at room temperature, however, the frequency can be trimmed for other voltage or temperature conditions using software in the following ways:

- **Default calibration:** clear the `UTEN` bit and set the `UPDATE` bit in the **Precision Internal Oscillator Calibration (PIOSCCAL)** register.
- **User-defined calibration:** The user can program the `UT` value to adjust the PIOSC frequency. As the `UT` value increases, the generated period increases. To commit a new `UT` value, first set the `UTEN` bit, then program the `UT` field, and then set the `UPDATE` bit. The adjustment finishes within a few clock periods and is glitch free.
- **Automatic calibration using the enable 32.768-kHz oscillator from the Hibernation module:** Set the `CAL` bit in the **PIOSCCAL** register; the results of the calibration are shown in the `RESULT` field in the **Precision Internal Oscillator Statistic (PIOSCSTAT)** register. After calibration is complete, the PIOSC is trimmed using the trimmed value returned in the `CT` field.

5.2.5.4 Main Oscillator (MOSC)

The main oscillator supports the use of crystals from 5 to 25 MHz. The system control's **RSCLKCFG** register can be configured to specify the MOSC as the system clock or as the PLL input source. The MOSC can be selected as the oscillator source by programming the `OSCRC` bit in the **RSCLKCFG** register. The `NOXTAL` bit in the **MOSCCTL** register allows the user to turn off power to the MOSC if no crystal is connected reducing power draw from the MOSC circuit.

Main Oscillator Verification Circuit

The clock control includes circuitry to ensure that the main oscillator is running at the appropriate frequency. The circuit monitors the main oscillator frequency and signals if the frequency is outside of the allowable band of attached crystals.

The detection circuit is enabled using the `CVAL` bit in the **Main Oscillator Control (MOSCCTL)** register. If this circuit is enabled and detects an error, and if the `MOSCIM` bit in the **MOSCCTL** register is clear, then the following sequence is performed by the hardware:

1. The `MOSCFAIL` bit in the **Reset Cause (RESC)** register is set.
2. The system clock is switched from the main oscillator to the PIOSC.
3. An internal system reset is initiated.
4. Reset is deasserted and the processor is directed to the NMI handler during the reset sequence.

5.2.5.5 PLL

The PLL has two modes of operation: Normal and Power-Down

- **Normal:** The PLL oscillates based on the values in the **PLLREQ0** and **PLLREQ1** registers and drives the output.

- Power-Down: Most of the PLL internal circuitry is disabled and the PLL does not drive the output.

The modes are programmed using the `PLL_PWR` bit in the **PLL_FREQ0** register (see page 299).

PLL Configuration

The PLL is disabled by default during power-on reset and is enabled later by software if required. Software specifies the output divisor to set the system clock frequency and enables the PLL to drive the output. The PLL is controlled using the **PLL_FREQ0**, **PLL_FREQ1** and **PLL_STAT** registers. Changes made to these registers do not become active until after the `NEW_FREQ` bit in the **RSCLKCFG** register is enabled.

The clock source for the main PLL is selected by configuring the `PLL_SRC` field in the **Run and Sleep Clock Configuration (RSCLKCFG)** register.

The PLL allows for the generation of system clock frequencies in excess of the reference clock provided. The reference clocks for the PLL are the `PIOSC` and the `MOSC`. The PLL is controlled by two registers, **PLL_FREQ0** and **PLL_FREQ1**. The PLL VCO frequency (f_{VCO}) is determined through the following calculation:

$$f_{VCO} = f_{IN} * MDIV$$

where

$$f_{IN} = f_{XTAL} / (Q+1)(N+1) \text{ or } f_{PIOSC} / (Q+1)(N+1)$$

$$MDIV = MINT + (MFRAC / 1024)$$

The `Q` and `N` values are programmed in the **PLL_FREQ1** register. Note that to reduce jitter, `MFRAC` should be programmed to `0x0`.

When the PLL is active, the system clock frequency (`SysClk`) is calculated using the following equation:

$$SysClk = f_{VCO} / (PSYSDIV + 1)$$

The PLL system divisor factor (`PSYSDIV`) determines the value of the system clock. Table 5-6 on page 244 shows how the system divisor encodings affect the system clock frequency when the $f_{VCO} = 480$ MHz.

Table 5-6. System Divisor Factors for $f_{VCO}=480$ MHz

System Clock (SYSCLK) (MHz)	f_{VCO} (MHz)= 480 MHz
	System Divisors ($PSYSDIV + 1$) ^a
120	4
60	8
48	10
30	16
24	20
12	40
6	80

a. The use of non-integer divisors introduce additional jitter which may affect interface performance.

If the main oscillator provides the clock reference to the PLL, the translation provided by hardware and used to program the PLL is available for software in the **PLL Frequency n (PLLFREQn)** registers (see page 299). The internal translation provides a translation within $\pm 1\%$ of the targeted PLL VCO frequency. Table 5-7 on page 245 shows the actual PLL frequency and error for a given crystal choice.

Table 5-7 on page 245 provides examples of the programming expected for the **PLLREQ0** and **PLLREQ1** registers. The first column specifies the input crystal frequency and the last column displays the PLL frequency given the values of **MINT** and **N**, when **Q=0**.

Table 5-7. Actual PLL Frequency^a

Crystal Frequency (MHz)	MINT (Decimal Value)	MINT (Hexadecimal Value)	N	Reference Frequency (MHz) ^b	PLL Frequency (MHz)
5	64	0x40	0x0	5	320
6	160	0x35	0x2	2	320
8	40	0x28	0x0	8	320
10	32	0x20	0x0	10	320
12	80	0x50	0x2	4	320
16	20	0x14	0x0	16	320
18	160	0xA0	0x8	2	320
20	16	0x10	0x0	20	320
24	40	0x28	0x2	8	320
25	64	0x40	0x4	5	320
5	96	0x60	0x0	5	480
6	80	0x50	0x0	6	480
8	60	0x3C	0x0	8	480
10	48	0x30	0x0	10	480
12	40	0x28	0x0	12	480
16	30	0x1E	0x0	16	480
18	80	0x50	0x2	6	480
20	24	0x18	0x0	20	480
24	20	0x14	0x0	24	480
25	96	0x60	0x4	5	480

a. For all examples listed, **Q=0**

b. For a given crystal frequency, **N** should be chosen such that the reference frequency is within 4 to 30 MHz.

PLL Operation

If a PLL configuration is changed, the PLL output frequency is unstable until it reconverges (relocks) to the new setting. The time between the configuration change and relock is T_{READY} (see Table 30-16 on page 1959). During the relock time, the affected PLL is not usable as a clock reference. Software can poll the **LOCK** bit in the **PLL Status (PLLSTAT)** register to determine when the PLL has locked.

Modification of the PLL VCO frequency may not be performed while the PLL serves as a clock source to the system. All changes to the PLL must be performed using a different clock source until the PLL has locked frequency. Thus, changing the PLL VCO frequency must be done as a sequence from PLL to PIOSC/MOSC and then PIOSC/MOSC to new PLL.

Hardware is provided to keep the PLL from being used as a system clock until the T_{READY} condition is met after one of the two changes above. It is the user's responsibility to have a stable clock source (like the main oscillator) before the **RSCLKCFG** register is re-programmed to enable the PLL. Software can use many methods to ensure that the system is clocked from the PLL, including periodically polling the `PLLLRIS` bit in the **Raw Interrupt Status (RIS)** register at offset 0x050, and enabling the PLL Lock interrupt in the **Interrupt Mask Control (IMC)** register at offset 0x054.

5.2.6 System Control

There are four levels of operation for the microcontroller defined as:

- Run mode
- Sleep mode
- Deep-Sleep mode
- Hibernation mode

For power-savings purposes, the peripheral-specific **RCGCx**, **SCGCx**, and **DCGCx** registers (for example, **RCGCWD**) control the clock-gating logic for that peripheral or block in the system while the microcontroller is in Run, Sleep, and Deep-Sleep mode, respectively. These registers are located in the System Control register map starting at offsets 0x600, 0x700, and 0x800, respectively.

Note: A change in the **RCGCx** (or **SCGCx/DCGCx/PCx/SRx**) registers may not have an immediate effect on the clock in all situations. It is recommended that software poll the peripheral's **Peripheral Ready (PRx)** register to determine when a peripheral is ready to be accessed.

Note: If a peripheral is configured to be clock-gated during Run, Sleep- or Deep-Sleep mode, then software should ensure that there are no pending transfers or register accesses before or immediately after entering the clock-gated mode.

The following sections describe the different modes in detail.

5.2.6.1 Run Mode

In Run mode, the microcontroller actively executes code. Run mode provides normal operation of the processor and all of the peripherals that are currently enabled by the peripheral-specific **RCGC** registers. In run mode (and in sleep mode), the **Run and Sleep Clock Configuration (RSCLKCFG)** register specifies the source of SysClk. The source is either from the VCO output of the PLL divided down by a dedicated divisor (divisor value specified by the `PSYSDIV` field) or from the output of an oscillator divided down by a dedicated divisor (divisor value specified by the `OSYSDIV` field). The source is selected using the `USEPLL` bit in the **RSCLKCFG** register. The PLL has two sources of reference clock as an input: the main oscillator (MOSC) or the precision internal oscillator (PIOSC). The PLL input select is specified by `PLLSRC`. If the PLL VCO output is not selected as the source of SysClk then the following reference clocks can be programmed as an input:

- Main Oscillator (MOSC)
- Precision Internal Oscillator (PIOSC)
- Low-Frequency Internal Oscillator (LFIOSC)
- Hibernation Module Real-Time Oscillator Source (RTCOSC): The source of this signal can be either a 32.768-kHz oscillator source, an external 32.768-kHz clock source or the internal

Hibernation Module Low-Frequency Oscillator (HIBLFIOOSC). If this clock source is selected, it has to be enabled in the Hibernation Module as well.

The selection of these alternate sources is through the `OSCSRC` field in the `RSCLKCFG` register.

5.2.6.2 Sleep Mode

In Sleep mode, the clock frequency of the active peripherals is unchanged, but the processor and the memory subsystem are not clocked and therefore no longer execute code. Sleep mode is entered by the Cortex-M4F core executing a `WFI` (Wait for Interrupt) instruction. Any properly configured interrupt event in the system brings the processor back into Run mode. See “Power Management” on page 133 for more details.

Peripherals are clocked that are enabled in the peripheral-specific `SCGC` registers when auto-clock gating is enabled or the peripheral-specific `RCGC` registers when the auto-clock gating is disabled. The system clock has the same source and frequency as that during Run mode.

The option to use the PLL VCO or an alternate oscillator source such as `MOSC`, `PIOOSC`, Hibernation Module real time clock, or the `LFIOOSC` is the same as described in Run Mode. The `RSCLKCFG` register programming applies to Sleep Mode.

Additional sleep modes are available that lower the power consumption of the SRAM and Flash memory. However, the lower power consumption modes have slower sleep and wake-up times.

Caution – If the Cortex-M4F Debug Access Port (DAP) has been enabled, and the device wakes from a low power sleep or deep-sleep mode, the core may start executing code before all clocks to peripherals have been restored to their Run mode configuration. The DAP is usually enabled by software tools accessing the JTAG or SWD interface when debugging or flash programming. If this condition occurs, a Hard Fault is triggered when software accesses a peripheral with an invalid clock.

A software delay loop can be used at the beginning of the interrupt routine that is used to wake up a system from a `WFI` (Wait For Interrupt) instruction. This stalls the execution of any code that accesses a peripheral register that might cause a fault. This loop can be removed for production software as the DAP is most likely not enabled during normal execution.

Because the DAP is disabled by default (power on reset), the user can also power cycle the device. The DAP is not enabled unless it is enabled through the JTAG or SWD interface.

5.2.6.3 Deep-Sleep Mode

In Deep-Sleep mode, the clock frequency of the active peripherals may change (depending on the Deep-Sleep mode clock configuration) in addition to the processor clock being stopped. An interrupt returns the microcontroller to Run mode from one of the sleep modes; the sleep modes are entered on request from the code. Deep-Sleep mode is entered by first setting the `SLEEPDEEP` bit in the **System Control (SYSCTRL)** register (see page 180) and then executing a `WFI` instruction. Any properly configured interrupt event in the system brings the processor back into Run mode. See “Power Management” on page 133 for more details.

Note: If the Debug Access Port is enabled in Run Mode and attempts to transition into Deep-Sleep mode, the device is prevented from entering Deep-Sleep.

The Cortex-M4F processor core and the memory subsystem are not clocked in Deep-Sleep mode. Peripherals are clocked that are enabled in the peripheral-specific `DCGC` registers when auto-clock gating is enabled or the peripheral-specific `RCGC` registers when auto-clock gating is disabled. The system clock source is specified in the `DSCLKCFG` register. When the `DSCLKCFG` register is used, the internal oscillator source is powered up, if necessary, and other clocks are powered down. If the PLL is running at the time of the `WFI` instruction, hardware shuts down the PLL for power savings.

For further power savings the PIOSC can be disabled through the `PIOSCPD` bit in the **DSCLKCFG** register. When the Deep-Sleep exit event occurs, hardware brings the system clock back to the source and frequency it had at the onset of Deep-Sleep mode before enabling the clocks that had been stopped during the Deep-Sleep duration. If the PIOSC is used as the PLL reference clock source, it may continue to provide the clock during Deep-Sleep. See page 288.

Note: If the MOSC is chosen as the Deep-Sleep clock source in the **DSCLKCFG** register, the MOSC must also be configured as the Run and Sleep clock source in the **RSCLKCFG** register prior to entering Deep Sleep. If the PIOSC, LFIOSC, or Hibernation RTC Module Oscillator (HIBLFIOSC or 32-kHz crystal) is configured as the Run and Sleep clock source in the **RSCLKCFG** register, and the MOSC is configured as the Deep-Sleep clock source in the **DSCLKCFG** register, then two outcomes are possible:

- If the PIOSC is still powered in Deep Sleep (using the `PIOSCPD` bit in the **DSCLKCFG** register) then the PIOSC is utilized as the clock source when entering Deep Sleep and the device enters and exits the Deep-Sleep state normally. The MOSC is not used as the clock source in Deep Sleep.
- If the PIOSC has been configured to be powered down in Deep Sleep, then the device can enter the Deep-Sleep state, but cannot exit properly. This situation can be avoided by programming the MOSC as the Run and Sleep clock source in the **RSCLKCFG** register prior to entering Deep Sleep.

To provide the lowest possible Deep-Sleep power consumption as well the ability to wake the processor from a peripheral without reconfiguring the peripheral for a change in clock, some of the communications modules have a Clock Control register at offset `0xFC8` in the module register space. The `CS` field in the Clock Control register allows the user to select the PIOSC or ALTCLK as the clock source for the module's baud clock. When the microcontroller enters Deep-Sleep mode, the PIOSC or ALTCLK becomes the source for the module clock as well, which allows the transmit and receive FIFOs to continue operation while the part is in Deep-Sleep. Figure 5-6 on page 249 shows how the clocks are selected.

Figure 5-6. Module Clock Selection

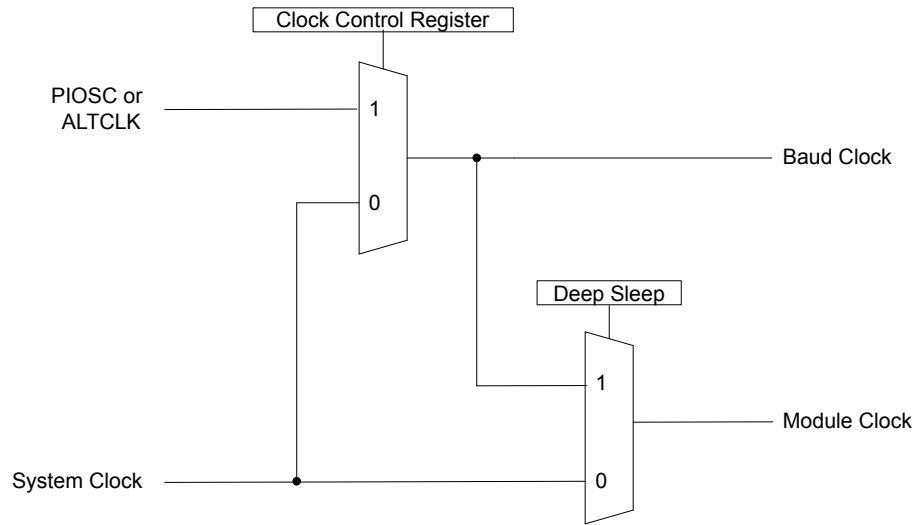

Additional power management modes are available that lower the power consumption of the peripheral memory, Flash, and SRAM memory. However, the lower power consumption modes have slower deep-sleep and wake-up times.

Note: If one or more wait states are configured for Run Mode, then when the device enters Deep-Sleep mode, it will achieve its lowest possible current. If there are no wait states applied in Run mode, then lowest possible current is not achieved.

5.2.6.4 Dynamic Power Management

In addition to the Sleep and Deep-Sleep modes and the clock gating for the on-chip modules, there are several additional power mode options that allow the LDO, Flash memory, and SRAM into different levels of power savings while in Sleep or Deep-Sleep modes. In addition, software has the ability to control the LDO settings to gain a power advantage when running at slower speeds. Note that these features may not be available on all devices; the **System Properties (SYSPROP)** register provides information on whether a mode is supported on a given MCU. The following registers provide these capabilities:

- **Peripheral Power Control (PCx):** Controls power to peripheral if that peripheral has the ability to respond to a power request.
- **Peripheral Memory Power Control (xMPC):** Provides power control to some the peripheral memory arrays.
- **LDO Sleep Power Control (LDOSPCTL):** Controls the LDO value in Sleep mode
- **LDO Deep-Sleep Power Control (LDODPCTL):** Controls the LDO value in Deep-Sleep mode
- **LDO Sleep Power Calibration (LDOSPCAL):** Provides factory recommendations for the LDO value in Sleep mode

- **LDO Deep-Sleep Power Calibration (LDODPCAL)**: Provides factory recommendations for the LDO value in Deep-Sleep mode
- **Sleep Power Configuration (SLPPWRCFG)**: Controls the power saving modes for Flash memory and SRAM in Sleep mode
- **Deep-Sleep Power Configuration (DSLPPWRCFG)**: Controls the power saving modes for Flash memory and SRAM in Deep-Sleep mode
- **Deep-Sleep Clock Configuration (DSCLKCFG)**: Controls the clocking in Deep-Sleep mode
- **Sleep / Deep-Sleep Power Mode Status (SDPMST)**: Provides status information on the various power saving events

Peripheral Power Control

The **Peripheral Power Control (PCx)** registers reside at offset 0x900 in the System Control module register space. For modules that reside in a separate power domain, the user has the capability to power down the module by setting the appropriate P_n bit to 0x0. This configuration provides the lowest power consumption state of the module. Currently the following registers can be programmed to disable power to the module:

- **PCCAN** register
- **PCEMAC** register
- **PCEPHY** register
- **PCUSB** register
- **PCCCM** register

Modification to other PCx registers have no effect, since they are not on their own power domain.

Peripheral Memory Power Control

When Deep-Sleep is entered, users have the capability to reduce power further in peripheral modules which have their own associated memory array. Many of these peripherals can be programmed to enable a low-power retention mode or a power down of their associated peripheral SRAM array. If retention is supported and the $PWRCTL$ bit field of the module's **xMPC** register is programmed to 0x1, the associated peripheral SRAM memory array is put in retention mode in which no accesses can be performed. When the $PWRCTL$ bit is set to 0x0 in Deep-Sleep mode, the memory is powered off, the contents are lost and the SRAM is not accessible. The peripheral's **Power Domain Status (xPDS)** can be read to determine the status of the peripheral's memory array as well as the peripheral's current power domain status. The table below lists the capabilities of peripherals with SRAM arrays during low power modes.

Table 5-8. Peripheral Memory Power Control

Module	Memory Retention Capability?	Memory Array Power Down Capability?
USB	Yes	Yes
EMAC	No	Yes (only when power domain is off, PCEMAC register = 0x0)
CAN	No	Yes

LDO Power Control

Note: While the device is connected through JTAG, the LDO control settings for Sleep or Deep-Sleep are not available and will not be applied.

Software can configure the **LDOSPCTL** register (see page 307) and/or the **LDODPCTL** register (see page 310) to dynamically raise or lower the LDO voltage in Sleep and Deep-Sleep mode depending on whether an increase in performance or reduction in power consumption is required. The **VLDO** field in the **LDOSPCTL** register is set to 1.2 V as default. The **LDODPCTL** register is set to an LDO voltage of 0.9 V as default. If an application requires performance over power consumption in Deep-Sleep, the Deep-Sleep LDO voltage can be configured to a higher voltage than 0.9 V during System Control initialization by setting the **VADJEN** bit and programming the **VLDO** field of the **LDODPCTL** register.

Before the LDO level is lowered in Sleep or Deep-Sleep, the system clock must be configured to an acceptable frequency in the **RSCLKCFG** register for Sleep mode and in **DSLPCCLKCFG** for Deep-Sleep mode. The following table shows the maximum System Clock and PIOSC frequency with respect to the LDO voltage.

Table 5-9. Maximum System Clock and PIOSC Frequency with Respect to LDO Voltage

Operating Voltage (LDO)	Maximum System Clock Frequency	PIOSC
1.2	120 MHz	16 MHz
0.9	30 MHz	16 MHz

The LDO Power Calibration registers, **LDOSPCAL** and **LDODPCAL**, provide suggested values for the LDO in the various modes. If software requests an LDO value that is too low or too high, the value is not accepted and an error is reported in the **SDPMST** register.

Note: When using the USB, Ethernet, EPI, and QSSI interfaces, the LDO must be configured to 1.2 V.

Flash Memory and SRAM Power Control

During Sleep or Deep-Sleep mode, Flash memory can be in either the default active mode or the low power mode; SRAM can be in the default active mode, standby mode, or low power mode. The active mode in each case provides the fastest times to sleep and wake up, but consumes more power. Low power mode provides the lowest power consumption, but takes longer to sleep and wake up.

The SRAM can be programmed to prohibit any power management by configuring the **SRAMP** bit in the **Sleep Power Configuration (SLPPWRCFG)** register. This configuration operates in the same way that legacy Stellaris® devices operate and provides the fastest sleep and wake-up times, but consumes the most power while in Sleep and Deep-Sleep mode.

The following power saving options are available in Sleep and Deep-Sleep modes:

- The clocks can be gated according to the settings in the peripheral-specific **SCGC** or **DCGC** registers.
- In Deep-Sleep mode, the clock source can be changed and the PIOSC can be powered off (if no active peripheral requires it) using the **DSCLKCFG** register. These options are not available for Sleep mode.
- The LDO voltage can be changed using the **LDOSPCTL** or **LDODPCTL** register.
- The Flash memory can be put into low power mode.

- The SRAM can be put into standby or low power mode.

For typical power consumption and sleep/wake-up times, refer to “Current Consumption” on page 2004 and “Sleep Modes” on page 1967.

The **SDPMST** register provides results on the Dynamic Power Management command issued. It also has some real time status that can be viewed by a debugger or the core if it is running. These events do not trigger an interrupt and are meant to provide information to help tune software for power management. The status register gets written at the beginning of every Dynamic Power Management event request that provides error checking. There is no mechanism to clear the bits; they are overwritten on the next event. The data is real time and there is no event to register that information.

5.2.6.5 Hibernation Mode

In this mode, the power supplies are turned off to the main part of the microcontroller and only the Hibernation module's circuitry is active. An external wake event or RTC event is required to bring the microcontroller back to Run mode. The Cortex-M4F processor and peripherals outside of the Hibernation module see a normal "power on" sequence and the processor starts running code. If the HIB module has been put in hibernation mode and a reset occurs, the reset handler should check the **HIB Raw Interrupt Status (HIBRIS)** register in the HIB module to determine the cause of the reset.

5.2.6.6 Hardware System Service Request

The **Hardware System Service Request (HSSR)** register is used to issue a request that returns a device to factory settings. An HSSR consists of writing the appropriate key and data structure address offset to the **HSSR** register in the System Control Module. Any HSSR initiates a reset event as the first event in the process. Then the **HSSR** register is evaluated.

To write to the **HSSR** register the **KEY** field must be set to 0xCA. The **CDOFF** field in the **HSSR** register can have one of the following three values:

- 0x00.0000 – No request and/or the previous request completed successfully
- 0xFF.FFFF – No request and the previous request failed
- Anything else – The offset into SRAM of a HSSR request structure

During the HSSR routine, if anything else is seen in the **CDOFF** field, then the offset is examined for validity and the structure it points to is examined for validity. If either is invalid, the request has failed and 0xFF.FFFF is written to the **CDOFF** field.

The offset is valid if all the following conditions are met:

- The **CDOFF** value is word aligned (that is, the two LSBs are both zero)
- The **CDOFF** value is at least 0x2000.4000
- The **CDOFF** value is at most 0x2003.FFF0

Once a valid HSSR offset is determined, the following structure is examined in the SRAM that is indicated by the **CDOFF** field in the **HSSR** register. In order to initiate a return-to-factory settings function, the data structure must be as follows:

- Request (32 bits) = 0xFEED.0001

- Data 1 (32 bits) = 0x0201.0100
- Data 2 (32 bits) = 0x0D08.0503
- Data 3 (32 bits) = 0x5937.2215

If the data bytes are correct, then the device is returned to factory condition. During the return-to-factory settings function, the following events occur:

- The RAM is erased in the Hibernation module
- The system SRAM is erased
- The **FMPPEn** registers are set to 0xFFFF.FFFF (to allow a Flash erase operation to occur)
- The EEPROM pages are erased
- A mass-erase of the flash array occurs
- The **BOOTCFG** register is written with 0xFFFF.FFFE

Once the return-to-factory settings sequence is completed, the **CDOFF** field of the **HSSR** register is written with 0x00.0000, indicating a successful completion and activating a system reset.

5.3 Initialization and Configuration

The PLL is configured using direct register writes to the **PLLREQn**, **MEMTIM0**, and **PLLSTAT** registers. The steps for initializing the system clock from POR to use the PLL from the main oscillator is as follows:

1. Once POR has completed, the PIOSC is acting as the system clock.
2. Power up the MOSC by clearing the **NOXTAL** bit in the **MOSCCTL** register.
3. If single-ended MOSC mode is required, the MOSC is ready to use. If crystal mode is required, clear the **PWRDN** bit and wait for the **MOSCPUPRIS** bit to be set in the **Raw Interrupt Status (RIS)**, indicating MOSC crystal mode is ready.
4. Set the **OSCSRC** field to 0x3 in the **RSCLKCFG** register at offset 0x0B0.
5. If the application also requires the MOSC to be the deep-sleep clock source, then program the **DSOSCSRC** field in the **DSCLKCFG** register to 0x3.
6. Write the **PLLREQ0** and **PLLREQ1** registers with the values of **Q**, **N**, **MINT**, and **MFRAC** to configure the desired VCO frequency setting.
7. Write the **MEMTIM0** register to correspond to the new system clock setting.
8. Wait for the **PLLSTAT** register to indicate the PLL has reached lock at the new operating point (or that a timeout period has passed and lock has failed, in which case an error condition exists and this sequence is abandoned and error processing is initiated).
9. Write the **RSCLKCFG** register's **PSYSDIV** value, set the **USEPLL** bit to enabled, and **MEMTIMU** bit.

If it is necessary to keep the MOSC powered on during automatic (deep-sleep) or accidental power down, then the `MOSCDPD` bit should be set to 0x1. Otherwise, if the `MOSCDPD` bit is set to 0x0, the MOSC is powered off when deep-sleep is entered or automatic power down occurs. The following table describes the relationship between the `PWRDN` bit in the **MOSCCTL** register and the `MOSCDPD` bit in the **DSCLKCFG** register:

Table 5-10. MOSC Configurations

PWRDN bit	MOSCDPD field	Result
0	0	MOSC is powered ON in run and sleep modes, but is disabled in accidental power down, when the <code>PWRDN</code> bit is set in the MOSCCTL register, or in deep-sleep mode only if it is not the deep-sleep clock source (<code>DSOSCSRC != 0x3</code>).
0	1	MOSC is powered and running in run, sleep and deep-sleep modes.
1	0	MOSC is powered off, and does not run in any mode. Please note, that in this configuration, when the MOSC is disabled, the MOSC must not be chosen as a clock source or indeterminate results occur.
1	1	MOSC runs and does not disable itself in run, sleep, and deep-sleep modes regardless of the fact that the <code>PWRDN</code> bit is set.

Note: The `MOSCDPD` bit has an effect in all modes of operation

To change the system clock frequency by changing its corresponding `PSYSDIV` or `OSYSDIV` value, a user must ensure timing parameters to memory are within range through the following steps:

1. If the change in system clock frequency changes the operational range of the timing parameters, the **MENTIMO** register must be updated. If so, write the timing configuration register, **MENTIMO**, setting the value to correspond to the final `SYCLK` frequency ($f_{VCO}/\text{new SYSDIV}$ or f_{OSC}). Otherwise the **MENTIMO** register should not be changed.
2. Write the **RSCLKCFG** register's `PSYSDIV` value and `MENTIMU` bit if the **MENTIMO** register is updated in the first step. The new `SYSDIV` is now in effect.

5.4 Register Map

Table 5-11 on page 254 lists the System Control registers, grouped by function. The offset listed is a hexadecimal increment to the register's address, relative to the System Control base address of 0x400F.E000.

Note: Spaces in the System Control register space that are not used are reserved for future or internal use. Software should not modify any reserved memory address.

Additional Flash and ROM registers defined in the System Control register space are described in the "Internal Memory" on page 608.

Table 5-11. System Control Register Map

Offset	Name	Type	Reset	Description	See page
System Control Registers (System Control Offset)					
0x000	DID0	RO	-	Device Identification 0	262
0x004	DID1	RO	0x102D.C06E	Device Identification 1	264
0x038	PTBOCTL	RW	0x0000.0003	Power-Temp Brown Out Control	266

Table 5-11. System Control Register Map (continued)

Offset	Name	Type	Reset	Description	See page
0x050	RIS	RO	0x0000.0000	Raw Interrupt Status	268
0x054	IMC	RW	0x0000.0000	Interrupt Mask Control	270
0x058	MISC	RW1C	0x0000.0000	Masked Interrupt Status and Clear	272
0x05C	RESC	RW	0x0000.0002	Reset Cause	274
0x060	PWRTC	RW1C	0x0000.0000	Power-Temperature Cause	277
0x064	NMIC	RW	0x0000.0000	NMI Cause Register	278
0x07C	MOSCCTL	RW	0x0000.000C	Main Oscillator Control	280
0x0B0	RSCLKCFG	RW	0x0000.0000	Run and Sleep Mode Configuration Register	282
0x0C0	MEMTIM0	RW	0x0030.0030	Memory Timing Parameter Register 0 for Main Flash and EEPROM	284
0x138	ALTCLKCFG	RW	0x0000.0000	Alternate Clock Configuration	287
0x144	DSCLKCFG	RW	0x0000.0000	Deep Sleep Clock Configuration Register	288
0x148	DIVSCLK	RW	0x0000.0000	Divisor and Source Clock Configuration	291
0x14C	SYSPROP	RO	0x0003.1F31	System Properties	293
0x150	PIOSCCAL	RW	0x0000.0000	Precision Internal Oscillator Calibration	296
0x154	PIOSCSTAT	RO	0x0040.0040	Precision Internal Oscillator Statistics	298
0x160	PLLREQ0	RW	0x0000.0000	PLL Frequency 0	299
0x164	PLLREQ1	RW	0x0000.0000	PLL Frequency 1	300
0x168	PLLSTAT	RO	0x0000.0000	PLL Status	301
0x188	SLPPWRCFG	RW	0x0000.0000	Sleep Power Configuration	302
0x18C	DSLPPWRCFG	RW	0x0000.0000	Deep-Sleep Power Configuration	304
0x1A0	NVMSTAT	RO	0x0000.0001	Non-Volatile Memory Information	306
0x1B4	LDOSPCTL	RW	0x0000.0018	LDO Sleep Power Control	307
0x1B8	LDOSPCAL	RO	0x0000.1818	LDO Sleep Power Calibration	309
0x1BC	LDODPCTL	RW	0x0000.0012	LDO Deep-Sleep Power Control	310
0x1C0	LDODPCAL	RO	0x0000.1212	LDO Deep-Sleep Power Calibration	312
0x1CC	SDPMST	RO	0x0000.0000	Sleep / Deep-Sleep Power Mode Status	313
0x1D8	RESBEHAVCTL	RW	0xFFFF.FFFF	Reset Behavior Control Register	316
0x1F4	HSSR	RW	0x0000.0000	Hardware System Service Request	318
0x280	USBPDS	RO	0x0000.003F	USB Power Domain Status	319
0x284	USBMPC	RW	0x0000.0003	USB Memory Power Control	320
0x288	EMACPDS	RO	0x0000.003F	Ethernet MAC Power Domain Status	321

Table 5-11. System Control Register Map (continued)

Offset	Name	Type	Reset	Description	See page
0x28C	EMACMPC	RW	0x0000.0003	Ethernet MAC Memory Power Control	322
0x298	CAN0PDS	RO	0x0000.003F	CAN 0 Power Domain Status	323
0x29C	CAN0MPC	RW	0x0000.0003	CAN 0 Memory Power Control	324
0x2A0	CAN1PDS	RO	0x0000.003F	CAN 1 Power Domain Status	325
0x2A4	CAN1MPC	RW	0x0000.0003	CAN 1 Memory Power Control	326
0x300	PPWD	RO	0x0000.0003	Watchdog Timer Peripheral Present	327
0x304	PPTIMER	RO	0x0000.00FF	16/32-Bit General-Purpose Timer Peripheral Present	328
0x308	PPGPIO	RO	0x0000.7FFF	General-Purpose Input/Output Peripheral Present	330
0x30C	PPDMA	RO	0x0000.0001	Micro Direct Memory Access Peripheral Present	333
0x310	PPEPI	RO	0x0000.0001	EPI Peripheral Present	334
0x314	PPHIB	RO	0x0000.0001	Hibernation Peripheral Present	335
0x318	PPUART	RO	0x0000.00FF	Universal Asynchronous Receiver/Transmitter Peripheral Present	336
0x31C	PPSSI	RO	0x0000.000F	Synchronous Serial Interface Peripheral Present	338
0x320	PPI2C	RO	0x0000.03FF	Inter-Integrated Circuit Peripheral Present	340
0x328	PPUSB	RO	0x0000.0001	Universal Serial Bus Peripheral Present	342
0x330	PPEPHY	RO	0x0000.0001	Ethernet PHY Peripheral Present	343
0x334	PPCAN	RO	0x0000.0003	Controller Area Network Peripheral Present	344
0x338	PPADC	RO	0x0000.0003	Analog-to-Digital Converter Peripheral Present	345
0x33C	PPACMP	RO	0x0000.0001	Analog Comparator Peripheral Present	346
0x340	PPPWM	RO	0x0000.0001	Pulse Width Modulator Peripheral Present	347
0x344	PPQEI	RO	0x0000.0001	Quadrature Encoder Interface Peripheral Present	348
0x348	PPLPC	RO	0x0000.0000	Low Pin Count Interface Peripheral Present	349
0x350	PPPECI	RO	0x0000.0000	Platform Environment Control Interface Peripheral Present	350
0x354	PPFAN	RO	0x0000.0000	Fan Control Peripheral Present	351
0x358	PPEEPROM	RO	0x0000.0001	EEPROM Peripheral Present	352
0x35C	PPWTIMER	RO	0x0000.0000	32/64-Bit Wide General-Purpose Timer Peripheral Present	353
0x370	PPRTS	RO	0x0000.0000	Remote Temperature Sensor Peripheral Present	354
0x374	PPCCM	RO	0x0000.0001	CRC and Cryptographic Modules Peripheral Present	355
0x390	PPLCD	RO	0x0000.0000	LCD Peripheral Present	356
0x398	PPOWIRE	RO	0x0000.0000	1-Wire Peripheral Present	357

Table 5-11. System Control Register Map (continued)

Offset	Name	Type	Reset	Description	See page
0x39C	PPEMAC	RO	0x0000.0001	Ethernet MAC Peripheral Present	358
0x3A0	PPPRB	RO	0x0000.0000	Power Regulator Bus Peripheral Present	359
0x3A4	PPHIM	RO	0x0000.0000	Human Interface Master Peripheral Present	360
0x500	SRWD	RW	0x0000.0000	Watchdog Timer Software Reset	361
0x504	SRTIMER	RW	0x0000.0000	16/32-Bit General-Purpose Timer Software Reset	362
0x508	SRGPIO	RW	0x0000.0000	General-Purpose Input/Output Software Reset	364
0x50C	SRDMA	RW	0x0000.0000	Micro Direct Memory Access Software Reset	367
0x510	SREPI	RW	0x0000.0000	EPI Software Reset	368
0x514	SRHIB	RW	0x0000.0000	Hibernation Software Reset	369
0x518	SRUART	RW	0x0000.0000	Universal Asynchronous Receiver/Transmitter Software Reset	370
0x51C	SRSSI	RW	0x0000.0000	Synchronous Serial Interface Software Reset	372
0x520	SRI2C	RW	0x0000.0000	Inter-Integrated Circuit Software Reset	374
0x528	SRUSB	RW	0x0000.0000	Universal Serial Bus Software Reset	376
0x530	SREPHY	RW	0x0000.0000	Ethernet PHY Software Reset	377
0x534	SRCAN	RW	0x0000.0000	Controller Area Network Software Reset	378
0x538	SRADC	RW	0x0000.0000	Analog-to-Digital Converter Software Reset	379
0x53C	SRACMP	RW	0x0000.0000	Analog Comparator Software Reset	380
0x540	SRPWM	RW	0x0000.0000	Pulse Width Modulator Software Reset	381
0x544	SRQEI	RW	0x0000.0000	Quadrature Encoder Interface Software Reset	382
0x558	SREEPROM	RW	0x0000.0000	EEPROM Software Reset	383
0x574	SRCCM	RW	0x0000.0000	CRC and Cryptographic Modules Software Reset	384
0x59C	SREMAC	RW	0x0000.0000	Ethernet MAC Software Reset	385
0x600	RCGCWD	RW	0x0000.0000	Watchdog Timer Run Mode Clock Gating Control	386
0x604	RCGCTIMER	RW	0x0000.0000	16/32-Bit General-Purpose Timer Run Mode Clock Gating Control	387
0x608	RCGCGPIO	RW	0x0000.0000	General-Purpose Input/Output Run Mode Clock Gating Control	389
0x60C	RCGCDMA	RW	0x0000.0000	Micro Direct Memory Access Run Mode Clock Gating Control	392
0x610	RCGCEPI	RW	0x0000.0000	EPI Run Mode Clock Gating Control	393
0x614	RCGCHIB	RW	0x0000.0001	Hibernation Run Mode Clock Gating Control	394
0x618	RCGCUART	RW	0x0000.0000	Universal Asynchronous Receiver/Transmitter Run Mode Clock Gating Control	395

Table 5-11. System Control Register Map (continued)

Offset	Name	Type	Reset	Description	See page
0x61C	RCGCSSI	RW	0x0000.0000	Synchronous Serial Interface Run Mode Clock Gating Control	397
0x620	RCGCI2C	RW	0x0000.0000	Inter-Integrated Circuit Run Mode Clock Gating Control	398
0x628	RCGCUSB	RW	0x0000.0000	Universal Serial Bus Run Mode Clock Gating Control	400
0x630	RCGCEPHY	RW	0x0000.0000	Ethernet PHY Run Mode Clock Gating Control	401
0x634	RCGCCAN	RW	0x0000.0000	Controller Area Network Run Mode Clock Gating Control	402
0x638	RCGCADC	RW	0x0000.0000	Analog-to-Digital Converter Run Mode Clock Gating Control	403
0x63C	RCGCACMP	RW	0x0000.0000	Analog Comparator Run Mode Clock Gating Control	404
0x640	RCGCPWM	RW	0x0000.0000	Pulse Width Modulator Run Mode Clock Gating Control	405
0x644	RCGCQEI	RW	0x0000.0000	Quadrature Encoder Interface Run Mode Clock Gating Control	406
0x658	RCGCEEPROM	RW	0x0000.0000	EEPROM Run Mode Clock Gating Control	407
0x674	RCGCCCM	RW	0x0000.0000	CRC and Cryptographic Modules Run Mode Clock Gating Control	408
0x69C	RCGCEMAC	RW	0x0000.0000	Ethernet MAC Run Mode Clock Gating Control	409
0x700	SCGCWD	RW	0x0000.0000	Watchdog Timer Sleep Mode Clock Gating Control	410
0x704	SCGCTIMER	RW	0x0000.0000	16/32-Bit General-Purpose Timer Sleep Mode Clock Gating Control	411
0x708	SCGCGPIO	RW	0x0000.0000	General-Purpose Input/Output Sleep Mode Clock Gating Control	413
0x70C	SCGCDMA	RW	0x0000.0000	Micro Direct Memory Access Sleep Mode Clock Gating Control	416
0x710	SCGCEPI	RW	0x0000.0000	EPI Sleep Mode Clock Gating Control	417
0x714	SCGCHIB	RW	0x0000.0001	Hibernation Sleep Mode Clock Gating Control	418
0x718	SCGCUART	RW	0x0000.0000	Universal Asynchronous Receiver/Transmitter Sleep Mode Clock Gating Control	419
0x71C	SCGCSSI	RW	0x0000.0000	Synchronous Serial Interface Sleep Mode Clock Gating Control	421
0x720	SCGCI2C	RW	0x0000.0000	Inter-Integrated Circuit Sleep Mode Clock Gating Control	422
0x728	SCGCUSB	RW	0x0000.0000	Universal Serial Bus Sleep Mode Clock Gating Control	424
0x730	SCGCEPHY	RW	0x0000.0000	Ethernet PHY Sleep Mode Clock Gating Control	425
0x734	SCGCCAN	RW	0x0000.0000	Controller Area Network Sleep Mode Clock Gating Control	426
0x738	SCGCADC	RW	0x0000.0000	Analog-to-Digital Converter Sleep Mode Clock Gating Control	427
0x73C	SCGCACMP	RW	0x0000.0000	Analog Comparator Sleep Mode Clock Gating Control	428

Table 5-11. System Control Register Map (continued)

Offset	Name	Type	Reset	Description	See page
0x740	SCGCPWM	RW	0x0000.0000	Pulse Width Modulator Sleep Mode Clock Gating Control	429
0x744	SCGCQEI	RW	0x0000.0000	Quadrature Encoder Interface Sleep Mode Clock Gating Control	430
0x758	SCGCEEPROM	RW	0x0000.0000	EEPROM Sleep Mode Clock Gating Control	431
0x774	SCGCCCM	RW	0x0000.0000	CRC and Cryptographic Modules Sleep Mode Clock Gating Control	432
0x79C	SCGCEMAC	RW	0x0000.0000	Ethernet MAC Sleep Mode Clock Gating Control	433
0x800	DCGCWD	RW	0x0000.0000	Watchdog Timer Deep-Sleep Mode Clock Gating Control	434
0x804	DCGCTIMER	RW	0x0000.0000	16/32-Bit General-Purpose Timer Deep-Sleep Mode Clock Gating Control	435
0x808	DCGCGPIO	RW	0x0000.0000	General-Purpose Input/Output Deep-Sleep Mode Clock Gating Control	437
0x80C	DCGCDMA	RW	0x0000.0000	Micro Direct Memory Access Deep-Sleep Mode Clock Gating Control	440
0x810	DCGCEPI	RW	0x0000.0000	EPI Deep-Sleep Mode Clock Gating Control	441
0x814	DCGCHIB	RW	0x0000.0001	Hibernation Deep-Sleep Mode Clock Gating Control	442
0x818	DCGCUART	RW	0x0000.0000	Universal Asynchronous Receiver/Transmitter Deep-Sleep Mode Clock Gating Control	443
0x81C	DCGCSSI	RW	0x0000.0000	Synchronous Serial Interface Deep-Sleep Mode Clock Gating Control	445
0x820	DCGCI2C	RW	0x0000.0000	Inter-Integrated Circuit Deep-Sleep Mode Clock Gating Control	446
0x828	DCGCUSB	RW	0x0000.0000	Universal Serial Bus Deep-Sleep Mode Clock Gating Control	448
0x830	DCGCEPHY	RW	0x0000.0000	Ethernet PHY Deep-Sleep Mode Clock Gating Control	449
0x834	DCGCCAN	RW	0x0000.0000	Controller Area Network Deep-Sleep Mode Clock Gating Control	450
0x838	DCGCADC	RW	0x0000.0000	Analog-to-Digital Converter Deep-Sleep Mode Clock Gating Control	451
0x83C	DCGCACMP	RW	0x0000.0000	Analog Comparator Deep-Sleep Mode Clock Gating Control	452
0x840	DCGCPWM	RW	0x0000.0000	Pulse Width Modulator Deep-Sleep Mode Clock Gating Control	453
0x844	DCGCQEI	RW	0x0000.0000	Quadrature Encoder Interface Deep-Sleep Mode Clock Gating Control	454
0x858	DCGCEEPROM	RW	0x0000.0000	EEPROM Deep-Sleep Mode Clock Gating Control	455
0x874	DCGCCCM	RW	0x0000.0000	CRC and Cryptographic Modules Deep-Sleep Mode Clock Gating Control	456
0x89C	DCGCEMAC	RW	0x0000.0000	Ethernet MAC Deep-Sleep Mode Clock Gating Control	457

Table 5-11. System Control Register Map (continued)

Offset	Name	Type	Reset	Description	See page
0x900	PCWD	RW	0x0000.0003	Watchdog Timer Power Control	458
0x904	PCTIMER	RW	0x0000.00FF	16/32-Bit General-Purpose Timer Power Control	460
0x908	PCGPIO	RW	0x0000.7FFF	General-Purpose Input/Output Power Control	463
0x90C	PCDMA	RW	0x0000.0001	Micro Direct Memory Access Power Control	468
0x910	PCEPI	RW	0x0000.0001	External Peripheral Interface Power Control	470
0x914	PCHIB	RW	0x0000.0001	Hibernation Power Control	472
0x918	PCUART	RW	0x0000.00FF	Universal Asynchronous Receiver/Transmitter Power Control	474
0x91C	PCSSI	RW	0x0000.000F	Synchronous Serial Interface Power Control	477
0x920	PCI2C	RW	0x0000.03FF	Inter-Integrated Circuit Power Control	479
0x928	PCUSB	RW	0x0000.0001	Universal Serial Bus Power Control	483
0x930	PCEPHY	RW	0x0000.0000	Ethernet PHY Power Control	485
0x934	PCCAN	RW	0x0000.0003	Controller Area Network Power Control	487
0x938	PCADC	RW	0x0000.0003	Analog-to-Digital Converter Power Control	489
0x93C	PCACMP	RW	0x0000.0001	Analog Comparator Power Control	491
0x940	PCPWM	RW	0x0000.0001	Pulse Width Modulator Power Control	493
0x944	PCQEI	RW	0x0000.0001	Quadrature Encoder Interface Power Control	495
0x958	PCEEPROM	RW	0x0000.0001	EEPROM Power Control	497
0x974	PCCCM	RW	0x0000.0001	CRC and Cryptographic Modules Power Control	499
0x99C	PCEMAC	RW	0x0000.0001	Ethernet MAC Power Control	501
0xA00	PRWD	RO	0x0000.0000	Watchdog Timer Peripheral Ready	503
0xA04	PRTIMER	RO	0x0000.0000	16/32-Bit General-Purpose Timer Peripheral Ready	504
0xA08	PRGPIO	RO	0x0000.0000	General-Purpose Input/Output Peripheral Ready	506
0xA0C	PRDMA	RO	0x0000.0000	Micro Direct Memory Access Peripheral Ready	509
0xA10	PREPI	RO	0x0000.0000	EPI Peripheral Ready	510
0xA14	PRHIB	RO	0x0000.0001	Hibernation Peripheral Ready	511
0xA18	PRUART	RO	0x0000.0000	Universal Asynchronous Receiver/Transmitter Peripheral Ready	512
0xA1C	PRSSI	RO	0x0000.0000	Synchronous Serial Interface Peripheral Ready	514
0xA20	PRI2C	RO	0x0000.0000	Inter-Integrated Circuit Peripheral Ready	516
0xA28	PRUSB	RO	0x0000.0000	Universal Serial Bus Peripheral Ready	519
0xA30	PREPHY	RO	0x0000.0000	Ethernet PHY Peripheral Ready	520
0xA34	PRCAN	RO	0x0000.0000	Controller Area Network Peripheral Ready	521

Table 5-11. System Control Register Map (continued)

Offset	Name	Type	Reset	Description	See page
0xA38	PRADC	RO	0x0000.0000	Analog-to-Digital Converter Peripheral Ready	522
0xA3C	PRACMP	RO	0x0000.0000	Analog Comparator Peripheral Ready	523
0xA40	PRPWM	RO	0x0000.0000	Pulse Width Modulator Peripheral Ready	524
0xA44	PRQEI	RO	0x0000.0000	Quadrature Encoder Interface Peripheral Ready	525
0xA58	PREEPROM	RO	0x0000.0000	EEPROM Peripheral Ready	526
0xA74	PRCCM	RO	0x0000.0000	CRC and Cryptographic Modules Peripheral Ready	527
0xA9C	PREMAC	RO	0x0000.0000	Ethernet MAC Peripheral Ready	528
0xF20	UNIQUEID0	RO	-	Unique ID 0	529
0xF24	UNIQUEID1	RO	-	Unique ID 1	529
0xF28	UNIQUEID2	RO	-	Unique ID 2	529
0xF2C	UNIQUEID3	RO	-	Unique ID 3	529
CCM System Control Registers (CCM Control Offset)					
0x204	CCMCGREQ	RW	0x0000.0000	Cryptographic Modules Clock Gating Request	530

5.5 System Control Register Descriptions (System Control Offset)

All addresses given are relative to the System Control base address of 0x400F.E000.

Register 1: Device Identification 0 (DID0), offset 0x000

This register identifies the version of the microcontroller. Each microcontroller is uniquely identified by the combined values of the `CLASS` field in the **DID0** register and the `PARTNO` field in the **DID1** register. The `MAJOR` and `MINOR` bit fields indicate the die revision number. Combined, the `MAJOR` and `MINOR` bit fields indicate the part revision number.

MAJOR Bitfield Value	MINOR Bitfield Value	Die Revision	Part Revision
0x0	0x0	A0	1
0x0	0x1	A1	2
0x0	0x2	A2	3

Device Identification 0 (DID0)

Base 0x400F.E000
 Offset 0x000
 Type RO, reset -

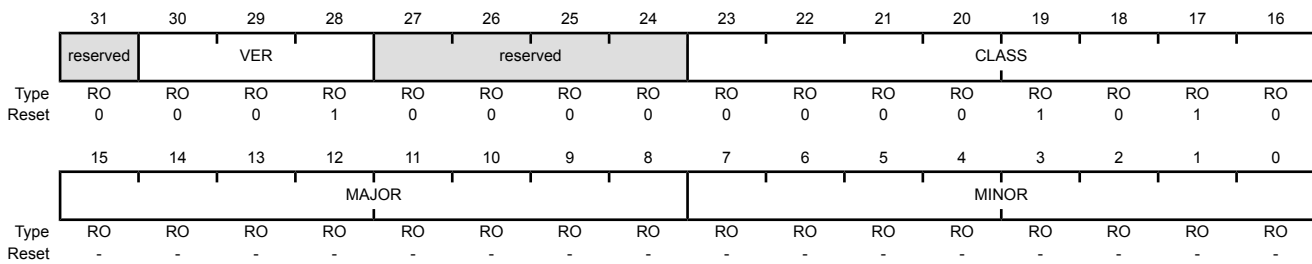

Bit/Field	Name	Type	Reset	Description				
31	reserved	RO	0	Software should not rely on the value of a reserved bit. To provide compatibility with future products, the value of a reserved bit should be preserved across a read-modify-write operation.				
30:28	VER	RO	0x1	<p>DID0 Version</p> <p>This field defines the DID0 register format version. The version number is numeric. The value of the <code>VER</code> field is encoded as follows (all other encodings are reserved):</p> <table border="1"> <thead> <tr> <th>Value</th> <th>Description</th> </tr> </thead> <tbody> <tr> <td>0x1</td> <td>Second version of the DID0 register format.</td> </tr> </tbody> </table>	Value	Description	0x1	Second version of the DID0 register format.
Value	Description							
0x1	Second version of the DID0 register format.							
27:24	reserved	RO	0	Software should not rely on the value of a reserved bit. To provide compatibility with future products, the value of a reserved bit should be preserved across a read-modify-write operation.				
23:16	CLASS	RO	0x0A	<p>Device Class</p> <p>The <code>CLASS</code> field value identifies the internal design from which all mask sets are generated for all microcontrollers in a particular product line. The <code>CLASS</code> field value is changed for new product lines, for changes in fab process (for example, a remap or shrink), or any case where the <code>MAJOR</code> or <code>MINOR</code> fields require differentiation from prior microcontrollers. The value of the <code>CLASS</code> field is encoded as follows (all other encodings are reserved):</p> <table border="1"> <thead> <tr> <th>Value</th> <th>Description</th> </tr> </thead> <tbody> <tr> <td>0x0A</td> <td>Tiva™ Snowflake-class microcontrollers</td> </tr> </tbody> </table>	Value	Description	0x0A	Tiva™ Snowflake-class microcontrollers
Value	Description							
0x0A	Tiva™ Snowflake-class microcontrollers							

Bit/Field	Name	Type	Reset	Description								
15:8	MAJOR	RO	-	<p>Major Revision</p> <p>This field specifies the major revision number of the microcontroller. The major revision reflects changes to base layers of the design. The major revision number is indicated in the part number as a letter (A for first revision, B for second, and so on). This field is encoded as follows:</p> <table border="1"> <thead> <tr> <th>Value</th> <th>Description</th> </tr> </thead> <tbody> <tr> <td>0x0</td> <td>Revision A (initial device)</td> </tr> <tr> <td>0x1</td> <td>Revision B (first base layer revision)</td> </tr> <tr> <td>0x2</td> <td>Revision C (second base layer revision)</td> </tr> </tbody> </table> <p>and so on.</p>	Value	Description	0x0	Revision A (initial device)	0x1	Revision B (first base layer revision)	0x2	Revision C (second base layer revision)
Value	Description											
0x0	Revision A (initial device)											
0x1	Revision B (first base layer revision)											
0x2	Revision C (second base layer revision)											
7:0	MINOR	RO	-	<p>Minor Revision</p> <p>This field specifies the minor revision number of the microcontroller. The minor revision reflects changes to the metal layers of the design. The MINOR field value is reset when the MAJOR field is changed. This field is numeric and is encoded as follows:</p> <table border="1"> <thead> <tr> <th>Value</th> <th>Description</th> </tr> </thead> <tbody> <tr> <td>0x0</td> <td>Initial device, or a major revision update.</td> </tr> <tr> <td>0x1</td> <td>First metal layer change.</td> </tr> <tr> <td>0x2</td> <td>Second metal layer change.</td> </tr> </tbody> </table> <p>and so on.</p>	Value	Description	0x0	Initial device, or a major revision update.	0x1	First metal layer change.	0x2	Second metal layer change.
Value	Description											
0x0	Initial device, or a major revision update.											
0x1	First metal layer change.											
0x2	Second metal layer change.											

Register 2: Device Identification 1 (DID1), offset 0x004

This register identifies the device family, part number, temperature range, pin count, and package type. Each microcontroller is uniquely identified by the combined values of the `CLASS` field in the `DID0` register and the `PARTNO` field in the `DID1` register.

Device Identification 1 (DID1)

Base 0x400F.E000
 Offset 0x004
 Type RO, reset 0x102D.C06E

	31	30	29	28	27	26	25	24	23	22	21	20	19	18	17	16
	VER				FAM				PARTNO							
Type	RO	RO	RO	RO	RO	RO	RO	RO	RO	RO	RO	RO	RO	RO	RO	RO
Reset	0	0	0	1	0	0	0	0	0	0	1	0	1	1	0	1
	15	14	13	12	11	10	9	8	7	6	5	4	3	2	1	0
	PINCOUNT			reserved				TEMP			PKG	ROHS	QUAL			
Type	RO	RO	RO	RO	RO	RO	RO	RO	RO	RO	RO	RO	RO	RO	RO	RO
Reset	1	1	0	0	0	0	0	0	0	1	1	0	1	1	1	0

Bit/Field	Name	Type	Reset	Description						
31:28	VER	RO	0x1	<p>DID1 Version</p> <p>This field defines the DID1 register format version. The version number is numeric. The value of the <code>VER</code> field is encoded as follows (all other encodings are reserved):</p> <table border="1"> <thead> <tr> <th>Value</th> <th>Description</th> </tr> </thead> <tbody> <tr> <td>0x0</td> <td>Initial DID1 register format definition, indicating a Stellaris LM3Snnn device.</td> </tr> <tr> <td>0x1</td> <td>Second version of the DID1 register format.</td> </tr> </tbody> </table>	Value	Description	0x0	Initial DID1 register format definition, indicating a Stellaris LM3Snnn device.	0x1	Second version of the DID1 register format.
Value	Description									
0x0	Initial DID1 register format definition, indicating a Stellaris LM3Snnn device.									
0x1	Second version of the DID1 register format.									
27:24	FAM	RO	0x0	<p>Family</p> <p>This field provides the family identification of the device within the Tiva™ product portfolio. The value is encoded as follows (all other encodings are reserved):</p> <table border="1"> <thead> <tr> <th>Value</th> <th>Description</th> </tr> </thead> <tbody> <tr> <td>0x0</td> <td>Tiva™ C Series microcontrollers and legacy Stellaris microcontrollers, that is, all devices with external part numbers starting with TM4Cor LM3S.</td> </tr> </tbody> </table>	Value	Description	0x0	Tiva™ C Series microcontrollers and legacy Stellaris microcontrollers, that is, all devices with external part numbers starting with TM4Cor LM3S.		
Value	Description									
0x0	Tiva™ C Series microcontrollers and legacy Stellaris microcontrollers, that is, all devices with external part numbers starting with TM4Cor LM3S.									
23:16	PARTNO	RO	0x2D	<p>Part Number</p> <p>This field provides the part number of the device within the family. This value indicates the TM4C129ENCPDT microcontroller.</p>						

Bit/Field	Name	Type	Reset	Description																		
15:13	PINCOUNT	RO	0x6	<p>Package Pin Count</p> <p>This field specifies the number of pins on the device package. The value is encoded as follows (all other encodings are reserved):</p> <table border="1"> <thead> <tr> <th>Value</th> <th>Description</th> </tr> </thead> <tbody> <tr> <td>0x0</td> <td>reserved</td> </tr> <tr> <td>0x1</td> <td>reserved</td> </tr> <tr> <td>0x2</td> <td>100-pin LQFP package</td> </tr> <tr> <td>0x3</td> <td>64-pin LQFP package</td> </tr> <tr> <td>0x4</td> <td>144-pin LQFP package</td> </tr> <tr> <td>0x5</td> <td>157-pin BGA package</td> </tr> <tr> <td>0x6</td> <td>128-pin TQFP package</td> </tr> <tr> <td>0x7</td> <td>212-pin BGA package</td> </tr> </tbody> </table>	Value	Description	0x0	reserved	0x1	reserved	0x2	100-pin LQFP package	0x3	64-pin LQFP package	0x4	144-pin LQFP package	0x5	157-pin BGA package	0x6	128-pin TQFP package	0x7	212-pin BGA package
Value	Description																					
0x0	reserved																					
0x1	reserved																					
0x2	100-pin LQFP package																					
0x3	64-pin LQFP package																					
0x4	144-pin LQFP package																					
0x5	157-pin BGA package																					
0x6	128-pin TQFP package																					
0x7	212-pin BGA package																					
12:8	reserved	RO	0x0	Software should not rely on the value of a reserved bit. To provide compatibility with future products, the value of a reserved bit should be preserved across a read-modify-write operation.																		
7:5	TEMP	RO	0x3	<p>Temperature Range</p> <p>This field specifies the temperature rating of the device. The value is encoded as follows (all other encodings are reserved):</p> <table border="1"> <thead> <tr> <th>Value</th> <th>Description</th> </tr> </thead> <tbody> <tr> <td>0x0</td> <td>Commercial temperature range</td> </tr> <tr> <td>0x1</td> <td>Industrial temperature range</td> </tr> <tr> <td>0x2</td> <td>Extended temperature range</td> </tr> </tbody> </table>	Value	Description	0x0	Commercial temperature range	0x1	Industrial temperature range	0x2	Extended temperature range										
Value	Description																					
0x0	Commercial temperature range																					
0x1	Industrial temperature range																					
0x2	Extended temperature range																					
4:3	PKG	RO	0x1	<p>Package Type</p> <p>This field specifies the package type. The value is encoded as follows (all other encodings are reserved):</p> <table border="1"> <thead> <tr> <th>Value</th> <th>Description</th> </tr> </thead> <tbody> <tr> <td>0x0</td> <td>reserved</td> </tr> <tr> <td>0x1</td> <td>QFP package</td> </tr> <tr> <td>0x2</td> <td>BGA package</td> </tr> </tbody> </table>	Value	Description	0x0	reserved	0x1	QFP package	0x2	BGA package										
Value	Description																					
0x0	reserved																					
0x1	QFP package																					
0x2	BGA package																					
2	ROHS	RO	0x1	<p>RoHS-Compliance</p> <p>This bit specifies whether the device is RoHS-compliant. A 1 indicates the part is RoHS-compliant.</p>																		
1:0	QUAL	RO	0x2	<p>Qualification Status</p> <p>This field specifies the qualification status of the device. The value is encoded as follows (all other encodings are reserved):</p> <table border="1"> <thead> <tr> <th>Value</th> <th>Description</th> </tr> </thead> <tbody> <tr> <td>0x0</td> <td>Engineering Sample (unqualified)</td> </tr> <tr> <td>0x1</td> <td>Pilot Production (unqualified)</td> </tr> <tr> <td>0x2</td> <td>Fully Qualified</td> </tr> </tbody> </table>	Value	Description	0x0	Engineering Sample (unqualified)	0x1	Pilot Production (unqualified)	0x2	Fully Qualified										
Value	Description																					
0x0	Engineering Sample (unqualified)																					
0x1	Pilot Production (unqualified)																					
0x2	Fully Qualified																					

Register 3: Power-Temp Brown Out Control (PTBOCTL), offset 0x038

This register determines, based on an individual event level, the appropriate next level of action (for example, NONE, System Control Interrupt, NMI, or reset) when an event occurs.

Power-temperature event actions are directed to the core as a System Control Interrupt or NMI. When a reset occurs, its behavior is controlled by the **Reset Behavior Control (RESBEHAVCTL)** register. If one of the events configured in the **PTBOCTL** register causes a reset, it is registered as a BOR interrupt in the **Reset Cause (RESC)** register.

Note: V_{DDA} is the supply voltage to the analog components of the device and V_{DD} is the supply voltage to the digital components of the device.

Power-Temp Brown Out Control (PTBOCTL)

Base 0x400F.E000

Offset 0x038

Type RW, reset 0x0000.0003

	31	30	29	28	27	26	25	24	23	22	21	20	19	18	17	16	
	reserved																
Type	RO	RO	RO	RO	RO	RO	RO	RO	RO	RO	RO	RO	RO	RO	RO	RO	
Reset	0	0	0	0	0	0	0	0	0	0	0	0	0	0	0	0	
	15	14	13	12	11	10	9	8	7	6	5	4	3	2	1	0	
	reserved				VDDA_UBOR		reserved									VDD_UBOR	
Type	RO	RO	RO	RO	RO	RO	RW	RW	RO	RO	RO	RO	RO	RO	RW	RW	
Reset	0	0	0	0	0	0	0	0	0	0	0	0	0	0	1	1	

Bit/Field	Name	Type	Reset	Description										
31:10	reserved	RO	0	Software should not rely on the value of a reserved bit. To provide compatibility with future products, the value of a reserved bit should be preserved across a read-modify-write operation.										
9:8	VDDA_UBOR	RW	0	<p>V_{DDA} under BOR Event Action</p> <p>An event occurs when V_{DDA} trips under the V_{DDA_BOR0} threshold found in Table 30-13 on page 1950.</p> <p>This field determines the action to take on the event.</p> <table border="0"> <tr> <td>Value</td> <td>Description</td> </tr> <tr> <td>0x0</td> <td>No Action</td> </tr> <tr> <td>0x1</td> <td>System control interrupt</td> </tr> <tr> <td>0x2</td> <td>NMI</td> </tr> <tr> <td>0x3</td> <td>Reset</td> </tr> </table>	Value	Description	0x0	No Action	0x1	System control interrupt	0x2	NMI	0x3	Reset
Value	Description													
0x0	No Action													
0x1	System control interrupt													
0x2	NMI													
0x3	Reset													
7:2	reserved	RO	0	Software should not rely on the value of a reserved bit. To provide compatibility with future products, the value of a reserved bit should be preserved across a read-modify-write operation.										

Bit/Field	Name	Type	Reset	Description
1:0	VDD_UBOR	RW	0x3	<p>V_{DD} under BOR Event Action</p> <p>An event occurs when V_{DD} trips under the V_{DD_BOR} threshold found in Table 30-13 on page 1950.</p> <p>This field determines the action to take on the event.</p> <p>Value Description</p> <p>0x0 No Action</p> <p>0x1 System control interrupt</p> <p>0x2 NMI</p> <p>0x3 Reset</p>

Register 4: Raw Interrupt Status (RIS), offset 0x050

This register indicates the status for system control raw interrupts. An interrupt is sent to the interrupt controller if the corresponding bit in the **Interrupt Mask Control (IMC)** register is set. Writing a 1 to the corresponding bit in the **Masked Interrupt Status and Clear (MISC)** register clears an interrupt status bit.

Raw Interrupt Status (RIS)

Base 0x400F.E000
Offset 0x050
Type RO, reset 0x0000.0000

	31	30	29	28	27	26	25	24	23	22	21	20	19	18	17	16
	reserved															
Type	RO	RO	RO	RO	RO	RO	RO	RO	RO	RO	RO	RO	RO	RO	RO	RO
Reset	0	0	0	0	0	0	0	0	0	0	0	0	0	0	0	0
	15	14	13	12	11	10	9	8	7	6	5	4	3	2	1	0
	reserved							MOSCPUPRIS	reserved	PLLLRIS	reserved		MOFRIS	reserved	BORRIS	reserved
Type	RO	RO	RO	RO	RO	RO	RO	RO	RO	RO	RO	RO	RO	RO	RO	RO
Reset	0	0	0	0	0	0	0	0	0	0	0	0	0	0	0	0

Bit/Field	Name	Type	Reset	Description
31:9	reserved	RO	0x0000.00	Software should not rely on the value of a reserved bit. To provide compatibility with future products, the value of a reserved bit should be preserved across a read-modify-write operation.
8	MOSCPUPRIS	RO	0	<p>MOSC Power Up Raw Interrupt Status</p> <p>Value Description</p> <p>0 Sufficient time has not passed for the MOSC to reach the expected frequency.</p> <p>1 Sufficient time has passed for the MOSC to reach the expected frequency. The value for this power-up time is indicated by T_{MOSC_START}.</p> <p>This bit is cleared by writing a 1 to the MOSCPUPMIS bit in the MISC register.</p>
7	reserved	RO	0	Software should not rely on the value of a reserved bit. To provide compatibility with future products, the value of a reserved bit should be preserved across a read-modify-write operation.
6	PLLLRIS	RO	0	<p>PLL Lock Raw Interrupt Status</p> <p>Value Description</p> <p>0 The PLL timer has not reached T_{READY}.</p> <p>1 The PLL timer has reached T_{READY} indicating that sufficient time has passed for the PLL to lock.</p> <p>This bit is cleared by writing a 1 to the PLLLMIS bit in the MISC register.</p>
5:4	reserved	RO	0x0	Software should not rely on the value of a reserved bit. To provide compatibility with future products, the value of a reserved bit should be preserved across a read-modify-write operation.

Bit/Field	Name	Type	Reset	Description
3	MOFRIS	RO	0	<p>Main Oscillator Failure Raw Interrupt Status</p> <p>Value Description</p> <p>0 The main oscillator has not failed.</p> <p>1 The <code>MOSCIM</code> bit in the <code>MOSCCTL</code> register is set and the main oscillator has failed.</p> <p>This bit is cleared by writing a 1 to the <code>MOFMIS</code> bit in the <code>MISC</code> register.</p>
2	reserved	RO	0	Software should not rely on the value of a reserved bit. To provide compatibility with future products, the value of a reserved bit should be preserved across a read-modify-write operation.
1	BORRIS	RO	0	<p>Brown-Out Reset Raw Interrupt Status</p> <p>Value Description</p> <p>0 A brown-out condition is not currently active.</p> <p>1 A brown-out condition is currently active.</p> <p>The appropriate BOR bit in the <code>PTBOCTL</code> register must be set to an interrupt (0x1) encoding in order to generate an interrupt.</p> <p>This bit is cleared by writing a 1 to the <code>BORMIS</code> bit in the <code>MISC</code> register.</p>
0	reserved	RO	0	Software should not rely on the value of a reserved bit. To provide compatibility with future products, the value of a reserved bit should be preserved across a read-modify-write operation.

Register 5: Interrupt Mask Control (IMC), offset 0x054

This register contains the mask bits for system control raw interrupts. A raw interrupt, indicated by a bit being set in the **Raw Interrupt Status (RIS)** register, is sent to the interrupt controller if the corresponding bit in this register is set.

Interrupt Mask Control (IMC)

Base 0x400F.E000
 Offset 0x054
 Type RW, reset 0x0000.0000

	31	30	29	28	27	26	25	24	23	22	21	20	19	18	17	16
	reserved															
Type	RO	RO	RO	RO	RO	RO	RO	RO	RO	RO	RO	RO	RO	RO	RO	RO
Reset	0	0	0	0	0	0	0	0	0	0	0	0	0	0	0	0
	15	14	13	12	11	10	9	8	7	6	5	4	3	2	1	0
	reserved							MOSCPUPIM	reserved	PLLLIM	reserved		MOFIM	reserved	BORIM	reserved
Type	RO	RO	RO	RO	RO	RO	RO	RW	RO	RW	RO	RO	RW	RO	RW	RO
Reset	0	0	0	0	0	0	0	0	0	0	0	0	0	0	0	0

Bit/Field	Name	Type	Reset	Description
31:9	reserved	RO	0x0000.00	Software should not rely on the value of a reserved bit. To provide compatibility with future products, the value of a reserved bit should be preserved across a read-modify-write operation.
8	MOSCPUPIM	RW	0	MOSC Power Up Interrupt Mask Value Description 0 The MOSCPUPRIS interrupt is suppressed and not sent to the interrupt controller. 1 An interrupt is sent to the interrupt controller when the MOSCPUPRIS bit in the RIS register is set.
7	reserved	RO	0	Software should not rely on the value of a reserved bit. To provide compatibility with future products, the value of a reserved bit should be preserved across a read-modify-write operation.
6	PLLLIM	RW	0	PLL Lock Interrupt Mask Value Description 0 The PLLLRIS interrupt is suppressed and not sent to the interrupt controller. 1 An interrupt is sent to the interrupt controller when the PLLLRIS bit in the RIS register is set.
5:4	reserved	RO	0x0	Software should not rely on the value of a reserved bit. To provide compatibility with future products, the value of a reserved bit should be preserved across a read-modify-write operation.

Bit/Field	Name	Type	Reset	Description
3	MOFIM	RW	0	Main Oscillator Failure Interrupt Mask Value Description 0 The MOFRIS interrupt is suppressed and not sent to the interrupt controller. 1 An interrupt is sent to the interrupt controller when the MOFRIS bit in the RIS register is set.
2	reserved	RO	0	Software should not rely on the value of a reserved bit. To provide compatibility with future products, the value of a reserved bit should be preserved across a read-modify-write operation.
1	BORIM	RW	0	Brown-Out Reset Interrupt Mask Value Description 0 The BORRIS interrupt is suppressed and not sent to the interrupt controller. 1 An interrupt is sent to the interrupt controller when the BORRIS bit in the RIS register is set.
0	reserved	RO	0	Software should not rely on the value of a reserved bit. To provide compatibility with future products, the value of a reserved bit should be preserved across a read-modify-write operation.

Register 6: Masked Interrupt Status and Clear (MISC), offset 0x058

On a read, this register gives the current masked status value of the corresponding interrupt in the **Raw Interrupt Status (RIS)** register. All of the bits are RW1C, thus writing a 1 to a bit clears the corresponding raw interrupt bit in the **RIS** register (see page 268).

Masked Interrupt Status and Clear (MISC)

Base 0x400F.E000
 Offset 0x058
 Type RW1C, reset 0x0000.0000

	31	30	29	28	27	26	25	24	23	22	21	20	19	18	17	16
	reserved															
Type	RO	RO	RO	RO	RO	RO	RO	RO	RO	RO	RO	RO	RO	RO	RO	RO
Reset	0	0	0	0	0	0	0	0	0	0	0	0	0	0	0	0
	15	14	13	12	11	10	9	8	7	6	5	4	3	2	1	0
	reserved							MOSCPUPMIS	reserved	PLLLMIS	reserved		MOFMIS	reserved	BORMIS	reserved
Type	RO	RO	RO	RO	RO	RO	RO	RW1C	RO	RW1C	RO	RO	RW1C	RO	RW1C	RO
Reset	0	0	0	0	0	0	0	0	0	0	0	0	0	0	0	0

Bit/Field	Name	Type	Reset	Description
31:9	reserved	RO	0x0000.00	Software should not rely on the value of a reserved bit. To provide compatibility with future products, the value of a reserved bit should be preserved across a read-modify-write operation.
8	MOSCPUPMIS	RW1C	0	MOSC Power Up Masked Interrupt Status Value Description 0 When read, a 0 indicates that sufficient time has not passed for the MOSC PLL to lock. A write of 0 has no effect on the state of this bit. 1 When read, a 1 indicates that an unmasked interrupt was signaled because sufficient time has passed for the MOSC PLL to lock. Writing a 1 to this bit clears it and also the MOSCPUPRIS bit in the RIS register.
7	reserved	RO	0	Software should not rely on the value of a reserved bit. To provide compatibility with future products, the value of a reserved bit should be preserved across a read-modify-write operation.
6	PLLLMIS	RW1C	0	PLL Lock Masked Interrupt Status Value Description 0 When read, a 0 indicates that sufficient time has not passed for the PLL to lock. A write of 0 has no effect on the state of this bit. 1 When read, a 1 indicates that an unmasked interrupt was signaled because sufficient time has passed for the PLL to lock. Writing a 1 to this bit clears it and also the PLLLRIS bit in the RIS register.

Bit/Field	Name	Type	Reset	Description
5:4	reserved	RO	0x0	Software should not rely on the value of a reserved bit. To provide compatibility with future products, the value of a reserved bit should be preserved across a read-modify-write operation.
3	MOFMIS	RW1C	0	<p>Main Oscillator Failure Masked Interrupt Status</p> <p>Value Description</p> <p>0 When read, a 0 indicates that the main oscillator has not failed. A write of 0 has no effect on the state of this bit.</p> <p>1 When read, a 1 indicates that an unmasked interrupt was signaled because the main oscillator failed. Writing a 1 to this bit clears it and also the MOFRIS bit in the RIS register.</p>
2	reserved	RO	0	Software should not rely on the value of a reserved bit. To provide compatibility with future products, the value of a reserved bit should be preserved across a read-modify-write operation.
1	BORMIS	RW1C	0	<p>BOR Masked Interrupt Status</p> <p>Value Description</p> <p>0 When read, a 0 indicates that a brown-out condition has not occurred. A write of 0 has no effect on the state of this bit.</p> <p>1 When read, a 1 indicates that an unmasked interrupt was signaled because of a brown-out condition. Writing a 1 to this bit clears it and also the BORRIS bit in the RIS register.</p>
0	reserved	RO	0	Software should not rely on the value of a reserved bit. To provide compatibility with future products, the value of a reserved bit should be preserved across a read-modify-write operation.

Register 7: Reset Cause (RESC), offset 0x05C

This register is set with the reset cause after reset. The bits in this register are sticky and maintain their state across multiple reset sequences. If a full POK-POR is initiated, the POR bit in the **RESC** register is set and all other bits are cleared. If the **WDOGn**, **BOR** or **EXTRES** configuration fields are set to 0x3 in the **RESBEHAVCTL** register and a simulated POR is initiated, the cause of the reset is reflected in the **RESC** register.

Note: After the **Reset Cause (RESC)** register is read, the **Hibernate Raw Interrupt Status (HIBRIS)** register in the Hibernation module must be evaluated to determine the full cause of the reset. Although an external reset assertion or POR resulting from a wake event is registered in the **RESC** register, the specific external wake source, including a low battery detect, is only registered in the **HIBRIS** register.

Reset Cause (RESC)

Base 0x400F.E000
 Offset 0x05C
 Type RW, reset 0x0000.0002

	31	30	29	28	27	26	25	24	23	22	21	20	19	18	17	16	
	reserved															MOSCFAIL	
Type	RO	RO	RO	RO	RO	RO	RO	RO	RO	RO	RO	RO	RO	RO	RO	RW	
Reset	0	0	0	0	0	0	0	0	0	0	0	0	0	0	0	-	
	15	14	13	12	11	10	9	8	7	6	5	4	3	2	1	0	
	reserved			HSSR	reserved							WDT1	SW	WDT0	BOR	POR	EXT
Type	RO	RO	RO	RW	RO	RO	RO	RO	RO	RO	RW	RW	RW	RW	RW	RW	
Reset	0	0	0	-	0	0	0	0	0	0	0	0	0	0	1	0	

Bit/Field	Name	Type	Reset	Description
31:17	reserved	RO	0x000	Software should not rely on the value of a reserved bit. To provide compatibility with future products, the value of a reserved bit should be preserved across a read-modify-write operation.
16	MOSCFAIL	RW	-	MOSC Failure Reset Writing a 0 to this bit clears it. Value Description 0 When read, this bit indicates that a MOSC failure has not generated a reset since the previous power-on reset. Writing a 0 to this bit clears it. 1 When read, this bit indicates that the MOSC circuit was enabled for clock validation and failed while the MOSCIM bit in the MOSCCTL register is clear, generating a reset event.
15:13	reserved	RO	0	Software should not rely on the value of a reserved bit. To provide compatibility with future products, the value of a reserved bit should be preserved across a read-modify-write operation.

Bit/Field	Name	Type	Reset	Description
12	HSSR	RW	-	HSSR Reset Value Description 0 When read, this bit indicates that a HSSR request has not generated a reset since the previous power-on reset. Writing a 0 to this bit clears it. 1 When read, this bit indicates that a HSSR request has generated a reset.
11:6	reserved	RO	0	Software should not rely on the value of a reserved bit. To provide compatibility with future products, the value of a reserved bit should be preserved across a read-modify-write operation.
5	WDT1	RW	0	Watchdog Timer 1 Reset Value Description 0 When read, this bit indicates that Watchdog Timer 1 has not generated a reset since the previous power-on reset. Writing a 0 to this bit clears it. 1 When read, this bit indicates that Watchdog Timer 1 timed out and generated a reset.
4	SW	RW	0	Software Reset Value Description 0 When read, this bit indicates that a software reset has not generated a reset since the previous power-on reset. Writing a 0 to this bit clears it. 1 When read, this bit indicates that a software reset has caused a reset event.
3	WDT0	RW	0	Watchdog Timer 0 Reset Value Description 0 When read, this bit indicates that Watchdog Timer 0 has not generated a reset since the previous power-on reset. Writing a 0 to this bit clears it. 1 When read, this bit indicates that Watchdog Timer 0 timed out and generated a reset.

Bit/Field	Name	Type	Reset	Description
2	BOR	RW	0	<p>Brown-Out Reset</p> <p>Note that for this bit, the BOR event that causes the Brown-Out Reset can be any of the following:</p> <ul style="list-style-type: none"> ■ The V_{DD} supply drops below its acceptable operating range. ■ The V_{DDA} supply drops below its acceptable operating range. <p>Value Description</p> <p>0 When read, this bit indicates that a brown-out reset has not generated a reset since the previous power-on reset. Writing a 0 to this bit clears it.</p> <p>1 When read, this bit indicates that a brown-out reset has caused a reset event.</p>
1	POR	RW	1	<p>Power-On Reset</p> <p>Value Description</p> <p>0 When read, this bit indicates that a power-on reset has not generated a reset. Writing a 0 to this bit clears it.</p> <p>1 When read, this bit indicates that a power-on reset has caused a reset event.</p>
0	EXT	RW	0	<p>External Reset</p> <p>Value Description</p> <p>0 When read, this bit indicates that an external reset (\overline{RST} assertion) has not caused a reset event since the previous power-on reset. Writing a 0 to this bit clears it.</p> <p>1 When read, this bit indicates that an external reset (\overline{RST} assertion) has caused a reset event.</p>

Register 8: Power-Temperature Cause (PWRTC), offset 0x060

This register provides detailed information on the power subsystem event that caused a reset or interrupt. The event sets the condition in this register without regard to whether it is used to generate a System control Interrupt, Reset, NMI, or no action. The **PTBOCTL** register contains the action to be taken on the specific events. The combination of the **PWRTC** register outputs and the **PTBOCTL** register causes the appropriate interrupt or reset condition to occur and the corresponding status bits to be set.

Power-Temperature Cause (PWRTC)

Base 0x400F.E000
Offset 0x060
Type RW1C, reset 0x0000.0000

	31	30	29	28	27	26	25	24	23	22	21	20	19	18	17	16
	reserved															
Type	RO	RO	RO	RO	RO	RO	RO	RO	RO	RO	RO	RO	RO	RO	RO	RO
Reset	0	0	0	0	0	0	0	0	0	0	0	0	0	0	0	0
	15	14	13	12	11	10	9	8	7	6	5	4	3	2	1	0
	reserved												VDDA_UBOR	reserved		VDD_UBOR
Type	RO	RO	RO	RO	RO	RO	RO	RO	RO	RO	RO	RW1C	RO	RO	RO	RW1C
Reset	0	0	0	0	0	0	0	0	0	0	0	0	0	0	0	0

Bit/Field	Name	Type	Reset	Description
31:5	reserved	RO	0	Software should not rely on the value of a reserved bit. To provide compatibility with future products, the value of a reserved bit should be preserved across a read-modify-write operation.
4	VDDA_UBOR	RW1C	0	V _{DDA} Under BOR Status Value Description 0 V _{DDA} has not tripped under voltage BOR comparison. 1 V _{DDA} has tripped under voltage BOR comparison.
3:1	reserved	RO	0	Software should not rely on the value of a reserved bit. To provide compatibility with future products, the value of a reserved bit should be preserved across a read-modify-write operation.
0	VDD_UBOR	RW1C	0	V _{DD} Under BOR Status Value Description 0 V _{DD} has not tripped under voltage BOR comparison. 1 V _{DD} has tripped under voltage BOR comparison.

Register 9: NMI Cause Register (NMIC), offset 0x064

This register provides the detailed information on the cause of an NMI interrupt. These bits are set via hardware when the event occurs AND the higher level control indicates that it should be NMI event.

Note: The **NMIC** register has to be cleared by the following sequence:

1. Read the **NMIC** register to identify the source of the NMI.
2. Clear the source of the NMI.
3. Read the **NMIC** register again to check the status.
4. Write a 0 into the **NMIC** register bit that corresponds with the NMI source.
5. Read the **NMIC** to check whether it is cleared. If not, repeat 3 on page 278 and 4 on page 278 again.

NMI Cause Register (NMIC)

Base 0x400F.E000
 Offset 0x064
 Type RW, reset 0x0000.0000

	31	30	29	28	27	26	25	24	23	22	21	20	19	18	17	16
	reserved															MOSCFAIL
Type	RO	RO	RO	RO	RO	RO	RO	RO	RO	RO	RO	RO	RO	RO	RO	RW
Reset	0	0	0	0	0	0	0	0	0	0	0	0	0	0	0	0
	15	14	13	12	11	10	9	8	7	6	5	4	3	2	1	0
	reserved						TAMPER	reserved			WDT1	reserved	WDT0	POWER	reserved	EXTERNAL
Type	RO	RO	RO	RO	RO	RO	RW	RO	RO	RO	RW	RO	RW	RW	RO	RW
Reset	0	0	0	0	0	0	0	0	0	0	0	0	0	0	0	0

Bit/Field	Name	Type	Reset	Description
31:17	reserved	RO	0	Software should not rely on the value of a reserved bit. To provide compatibility with future products, the value of a reserved bit should be preserved across a read-modify-write operation.
16	MOSCFAIL	RW	0	MOSC Failure NMI Value Description 0 No MOSC failure has occurred. 1 An NMI has occurred due to a MOSC failure.
15:10	reserved	RO	0	Software should not rely on the value of a reserved bit. To provide compatibility with future products, the value of a reserved bit should be preserved across a read-modify-write operation.

Bit/Field	Name	Type	Reset	Description
9	TAMPER	RW	0	<p>Tamper Event NMI</p> <p>Value Description</p> <p>0 No tamper event has occurred.</p> <p>1 An NMI has occurred due to a tamper event</p> <p>See the HIB module tamper registers for more details on the tamper event.</p>
8:6	reserved	RO	0	Software should not rely on the value of a reserved bit. To provide compatibility with future products, the value of a reserved bit should be preserved across a read-modify-write operation.
5	WDT1	RW	0	<p>Watch Dog Timer (WDT) 1 NMI</p> <p>Value Description</p> <p>0 No WDT 1 timeout has occurred.</p> <p>1 An NMI has occurred due to a Watchdog Timer 1 timeout event.</p>
4	reserved	RO	0	Software should not rely on the value of a reserved bit. To provide compatibility with future products, the value of a reserved bit should be preserved across a read-modify-write operation.
3	WDT0	RW	0	<p>Watch Dog Timer (WDT) 0 NMI</p> <p>Value Description</p> <p>0 No WDT 0 timeout has occurred.</p> <p>1 An NMI has occurred due to a Watchdog Timer 0 timeout event.</p>
2	POWER	RW	0	<p>Power/Brown Out Event NMI</p> <p>Value Description</p> <p>0 No power event has occurred.</p> <p>1 An NMI has occurred due to a power event.</p> <p>See PWRTC register for exact cause of power/brown-out event.</p>
1	reserved	RO	0	Software should not rely on the value of a reserved bit. To provide compatibility with future products, the value of a reserved bit should be preserved across a read-modify-write operation.
0	EXTERNAL	RW	0	<p>External Pin NMI</p> <p>Value Description</p> <p>0 No NMI pin event has occurred.</p> <p>1 The NMI pin was asserted by external hardware.</p>

Register 10: Main Oscillator Control (MOSCCTL), offset 0x07C

This register provides control over the features of the main oscillator, including the ability to enable the MOSC clock verification circuit, what action to take when the MOSC fails, and whether or not a crystal is connected. When enabled, this circuit monitors the frequency of the MOSC to verify that the oscillator is operating within specified limits. If the clock goes invalid after being enabled, the microcontroller issues a power-on reset and reboots to the NMI handler or generates an interrupt.

Note: If the MOSC is chosen as the clock to the Ethernet PHY then software has to enable the MOSC before enabling the Ethernet PHY by setting the P0 bit in the PCEPHY.

Main Oscillator Control (MOSCCTL)

Base 0x400F.E000
 Offset 0x07C
 Type RW, reset 0x0000.000C

	31	30	29	28	27	26	25	24	23	22	21	20	19	18	17	16	
	reserved																
Type	RO	RO	RO	RO	RO	RO	RO	RO	RO	RO	RO	RO	RO	RO	RO	RO	
Reset	0	0	0	0	0	0	0	0	0	0	0	0	0	0	0	0	
	15	14	13	12	11	10	9	8	7	6	5	4	3	2	1	0	
	reserved												OSCRNG	PWRDN	NOXTAL	MOSCIM	CVAL
Type	RO	RO	RO	RO	RO	RO	RO	RO	RO	RO	RO	RO	RW	RW	RW	RW	RW
Reset	0	0	0	0	0	0	0	0	0	0	0	0	0	1	1	0	0

Bit/Field	Name	Type	Reset	Description
31:5	reserved	RO	0x0000.000	Software should not rely on the value of a reserved bit. To provide compatibility with future products, the value of a reserved bit should be preserved across a read-modify-write operation.
4	OSCRNG	RW	0	Oscillator Range Specifies the frequency range of operation of the oscillator. Value Description 0 Low Frequency Range 1 High Frequency Range (equal to or greater than 10 MHz).
3	PWRDN	RW	1	Power Down Provides user control over powering down the main oscillator circuit. Value Description 0 Power to main oscillator circuit is enabled. 1 Main Oscillator circuit is powered down. Note: This bit should be cleared when using a crystal and set for single-ended mode.

Bit/Field	Name	Type	Reset	Description
2	NOXTAL	RW	1	<p>No MOSC/Crystal Connected</p> <p>Provides the user control over the power drawn from the main oscillator circuit. This bit should be set when either crystal or single-ended mode is being used.</p> <p>If the application needs MOSC, this bit should be cleared.</p> <p>Value Description</p> <p>0 This bit should be cleared when a crystal or oscillator is connected to the OSC0 and OSC1 inputs, regardless of whether or not the MOSC is used or powered down.</p> <p>Note: For proper clock functionality when switching to crystal mode, software must clear this bit and set the PWRDN bit in a single write access.</p> <p>1 This bit should be set when a crystal or external oscillator is not connected to the OSC0 and OSC1 inputs to reduce power consumption.</p>
1	MOSCIM	RW	0	<p>MOSC Failure Action</p> <p>Value Description</p> <p>0 If the MOSC fails, a MOSC failure reset is generated and reboots to the NMI handler.</p> <p>1 If the MOSC fails, an interrupt is generated as indicated by the MOSRIS bit in the RIS register.</p> <p>Regardless of the action taken, if the MOSC fails, the oscillator source is switched to the PIOSC automatically.</p>
0	CVAL	RW	0	<p>Clock Validation for MOSC</p> <p>Value Description</p> <p>0 The MOSC monitor circuit is disabled.</p> <p>1 The MOSC monitor circuit is enabled.</p>

Register 11: Run and Sleep Mode Configuration Register (RSCLKCFG), offset 0x0B0

Important: When transitioning the system clock configuration to use the MOSC as the fundamental clock source, the `PWRDN` bit must be set in the **MOSCCTL** register prior to reselecting the MOSC for proper operation.

Run and Sleep Mode Configuration Register (RSCLKCFG)

Base 0x400F.E000
Offset 0x0B0
Type RW, reset 0x0000.0000

	31	30	29	28	27	26	25	24	23	22	21	20	19	18	17	16
	MEMTIMU	NEWFREQ	ACG	USEPLL	PLLSRC				OSCSRC				OSYSDIV			
Type	R0/W	R0/W	RW	RW	RW	RW	RW	RW	RW	RW	RW	RW	RW	RW	RW	RW
Reset	0	0	0	0	0	0	0	0	0	0	0	0	0	0	0	0
	15	14	13	12	11	10	9	8	7	6	5	4	3	2	1	0
	OSYSDIV						PSYSDIV									
Type	RW	RW	RW	RW	RW	RW	RW	RW	RW	RW	RW	RW	RW	RW	RW	RW
Reset	0	0	0	0	0	0	0	0	0	0	0	0	0	0	0	0

Bit/Field	Name	Type	Reset	Description
31	MEMTIMU	R0/W	0	<p>Memory Timing Register Update</p> <p>Setting this bit causes the MEMTIMU register value to be applied, and the memory timing to be updated. Execution and access is suspended during the change.</p> <p>This bit is automatically cleared by hardware.</p>
30	NEWFREQ	R0/W	0	<p>New PLLFREQ Accept</p> <p>This bit controls the activation of the values in the PLLFREQ0 and PLLFREQ1 registers as applied to the PLL. Until NEWFREQ is written to a 1, writes to the PLLFREQ0 and PLLFREQ1 are deferred. When written with a 1, the values stored in PLLFREQ0 and PLLFREQ1 are applied to the PLL.</p> <p>This bit is automatically cleared by hardware. Software will not check the value after being set.</p>
29	ACG	RW	0x0	<p>Auto Clock Gating</p> <p>This bit specifies whether the system uses the Sleep-Mode Clock Gating Control (SCGCn) registers and Deep-Sleep-Mode Clock Gating Control (DCGCn) registers if the microcontroller enters a Sleep or Deep-Sleep mode (respectively).</p> <p>Value Description</p> <p>0 The Run-Mode Clock Gating Control (RCGCn) registers are used when the microcontroller enters a sleep mode.</p> <p>1 If the microcontroller is in sleep mode, the SCGCn registers are used to control the clocks distributed to the peripherals. If the microcontroller is in deep-sleep mode, the DCGCn registers are used to control the clocks distributed to the peripherals. The SCGCn and DCGCn registers allow unused peripherals to consume less power when the microcontroller is in a sleep mode.</p> <p>The RCGCn registers are always used to control the clocks in Run mode.</p>

Bit/Field	Name	Type	Reset	Description														
28	USEPLL	RW	0	<p>Use PLL</p> <p>This bit controls whether the clock source is specified by the <code>OSCSRC</code> field or the output of the PLL is provided to the system clock divider and serves as the system clock source.</p> <table border="1"> <thead> <tr> <th>Value</th> <th>Description</th> </tr> </thead> <tbody> <tr> <td>0</td> <td>Clock source specified by <code>OSCSRC</code> field.</td> </tr> <tr> <td>1</td> <td>Clock source specified by the PLL</td> </tr> </tbody> </table>	Value	Description	0	Clock source specified by <code>OSCSRC</code> field.	1	Clock source specified by the PLL								
Value	Description																	
0	Clock source specified by <code>OSCSRC</code> field.																	
1	Clock source specified by the PLL																	
27:24	PLLSRC	RW	0	<p>PLL Source</p> <p>This field specifies the PLL input clock source</p> <table border="1"> <thead> <tr> <th>Value</th> <th>Description</th> </tr> </thead> <tbody> <tr> <td>0x0</td> <td>PIOSC is the PLL input clock source</td> </tr> <tr> <td>0x1-0x2</td> <td>reserved</td> </tr> <tr> <td>0x3</td> <td>MOSC is the PLL input clock source</td> </tr> <tr> <td>0x4-0xFF</td> <td>Reserved</td> </tr> </tbody> </table>	Value	Description	0x0	PIOSC is the PLL input clock source	0x1-0x2	reserved	0x3	MOSC is the PLL input clock source	0x4-0xFF	Reserved				
Value	Description																	
0x0	PIOSC is the PLL input clock source																	
0x1-0x2	reserved																	
0x3	MOSC is the PLL input clock source																	
0x4-0xFF	Reserved																	
23:20	OSCSRC	RW	0	<p>Oscillator Source</p> <p>This field specifies the oscillator source that becomes the oscillator clock (<code>OSCCLK</code>) source, which is used when the PLL is bypassed during run or sleep modes.</p> <table border="1"> <thead> <tr> <th>Value</th> <th>Description</th> </tr> </thead> <tbody> <tr> <td>0x0</td> <td>PIOSC is oscillator source</td> </tr> <tr> <td>0x1</td> <td>reserved</td> </tr> <tr> <td>0x2</td> <td>LFIOSC is oscillator source</td> </tr> <tr> <td>0x3</td> <td>MOSC is oscillator source</td> </tr> <tr> <td>0x4</td> <td>Hibernation Module RTC Oscillator (<code>RTCOSC</code>)</td> </tr> <tr> <td>0x5-0xFF</td> <td>reserved</td> </tr> </tbody> </table>	Value	Description	0x0	PIOSC is oscillator source	0x1	reserved	0x2	LFIOSC is oscillator source	0x3	MOSC is oscillator source	0x4	Hibernation Module RTC Oscillator (<code>RTCOSC</code>)	0x5-0xFF	reserved
Value	Description																	
0x0	PIOSC is oscillator source																	
0x1	reserved																	
0x2	LFIOSC is oscillator source																	
0x3	MOSC is oscillator source																	
0x4	Hibernation Module RTC Oscillator (<code>RTCOSC</code>)																	
0x5-0xFF	reserved																	
19:10	OSYSDIV	RW	0	<p>Oscillator System Clock Divisor</p> <p>This field specifies the system clock divisor value for the oscillator path. This field is used when the <code>USEPLL</code> bit is 0.</p> $f_{\text{sysclk}} = f_{\text{oscclk}} / (\text{OSYSDIV} + 1)$ <p>The divisor value is the <code>OSYSDIV</code> field value + 1</p>														
9:0	PSYSDIV	RW	0	<p>PLL System Clock Divisor</p> <p>This field specifies the system clock divisor value for the PLL. This field is used when the <code>USEPLL</code> bit is 1.</p> $f_{\text{sysclk}} = f_{\text{VCO}} / (\text{PSYSDIV} + 1)$														

Register 12: Memory Timing Parameter Register 0 for Main Flash and EEPROM (MEMTIM0), offset 0x0C0

The **MEMTIM0** register provides timing parameters for the main Flash and EEPROM memories. The timing parameters apply to the memory while the system is in run or sleep mode; the clocking for these modes is consistent and unchanged since the system clock frequency and source remains unchanged during transitions between run-to-sleep and sleep-back-to-run. Writes to **MEMTIM0** do not have any effect on system state; the register contents are applied only when the **MEMTIMU** bit in the **RSCLKCFG** register is set. Doing so allows the software to execute out of the same memory system for which the timing parameters are being modified.

Depending on the CPU frequency, the application must program specific values into the fields of the **Memory Timing Parameter Register 0 for Main Flash and EEPROM (MEMTIM0)**. The following table details the bit field values that are required for the given CPU frequency ranges.

Table 5-12. MEMTIM0 Register Configuration versus Frequency

CPU Frequency range (f) in MHz	Time Period Range (t) in ns	FBCHT/EBCHT	FBCE/EBCE	FWS/EWS
16	62.5	0x0	1	0x0
16 < f ≤ 40	62.5 > t ≥ 25	0x2	0	0x1
40 < f ≤ 60	25 > t ≥ 16.67	0x3	0	0x2
60 < f ≤ 80	16.67 > t ≥ 12.5	0x4	0	0x3
80 < f ≤ 100	12.5 > t ≥ 10	0x5	0	0x4
100 < f ≤ 120	10 > t ≥ 8.33	0x6	0	0x5

Note: The associated Flash and EEPROM fields in the **MEMTIM0** register must be programmed to the same values. For example, the **FWS** field must be programmed to the same value as the **EWS** field.

Refer to “Flash Memory” on page 612 and “EEPROM” on page 623 for more information about Flash and EEPROM programming.

Memory Timing Parameter Register 0 for Main Flash and EEPROM (MEMTIM0)

Base 0x400F.E000
 Offset 0x0C0
 Type RW, reset 0x0030.0030

	31	30	29	28	27	26	25	24	23	22	21	20	19	18	17	16
	reserved						EBCHT				EBCE	reserved	EWS			
Type	RO	RO	RO	RO	RO	RO	RW	RW	RW	RW	RW	RW	RW	RW	RW	RW
Reset	0	0	0	0	0	0	0	0	0	0	1	1	0	0	0	0
	15	14	13	12	11	10	9	8	7	6	5	4	3	2	1	0
	reserved						FBCHT				FBCE	reserved	FWS			
Type	RW	RW	RW	RW	RW	RW	RW	RW	RW	RW	RW	RW	RW	RW	RW	RW
Reset	0	0	0	0	0	0	0	0	0	0	1	1	0	0	0	0

Bit/Field	Name	Type	Reset	Description
31:26	reserved	RO	0x0000.000	Software should not rely on the value of a reserved bit. To provide compatibility with future products, the value of a reserved bit should be preserved across a read-modify-write operation.

Bit/Field	Name	Type	Reset	Description																		
25:22	EBCHT	RW	0x0	<p>EEPROM Clock High Time Specifies the length of the EEPROM bank clock high time</p> <p>Value Description</p> <table border="1"> <tr><td>0x0</td><td>1/2 system clock period</td></tr> <tr><td>0x1</td><td>1 system clock period</td></tr> <tr><td>0x2</td><td>1.5 system clock periods</td></tr> <tr><td>0x3</td><td>2 system clock periods</td></tr> <tr><td>0x4</td><td>2.5 system clock periods</td></tr> <tr><td>0x5</td><td>3 system clock periods</td></tr> <tr><td>0x6</td><td>3.5 system clock periods</td></tr> <tr><td>0x7</td><td>4 system clock periods</td></tr> <tr><td>0x8</td><td>4.5 system clock periods</td></tr> </table>	0x0	1/2 system clock period	0x1	1 system clock period	0x2	1.5 system clock periods	0x3	2 system clock periods	0x4	2.5 system clock periods	0x5	3 system clock periods	0x6	3.5 system clock periods	0x7	4 system clock periods	0x8	4.5 system clock periods
0x0	1/2 system clock period																					
0x1	1 system clock period																					
0x2	1.5 system clock periods																					
0x3	2 system clock periods																					
0x4	2.5 system clock periods																					
0x5	3 system clock periods																					
0x6	3.5 system clock periods																					
0x7	4 system clock periods																					
0x8	4.5 system clock periods																					
21	EBCE	RW	1	<p>EEPROM Bank Clock Edge Specifies the relationship of EEPROM clock to system clock</p> <p>Value Description</p> <table border="1"> <tr><td>0</td><td>EEPROM clock rising aligns with system clock rising</td></tr> <tr><td>1</td><td>EEPROM clock rising aligns with system clock falling</td></tr> </table>	0	EEPROM clock rising aligns with system clock rising	1	EEPROM clock rising aligns with system clock falling														
0	EEPROM clock rising aligns with system clock rising																					
1	EEPROM clock rising aligns with system clock falling																					
20	reserved	RW	1	Software should not rely on the value of a reserved bit. To provide compatibility with future products, the value of a reserved bit should be preserved across a read-modify-write operation.																		
19:16	EWS	RW	0	<p>EEPROM Wait States This field specifies the number of wait states inserted.</p> <p>Value Description</p> <table border="1"> <tr><td>0x0</td><td>0 wait states</td></tr> <tr><td>0x1</td><td>1 wait state</td></tr> <tr><td>0x2</td><td>2 wait states</td></tr> <tr><td>0x3</td><td>3 wait states</td></tr> <tr><td>0x4</td><td>4 wait states</td></tr> <tr><td>0x5</td><td>5 wait states</td></tr> <tr><td>0x6</td><td>6 wait states</td></tr> <tr><td>0x7</td><td>7 wait states</td></tr> <tr><td>0x8-0xF</td><td>reserved</td></tr> </table>	0x0	0 wait states	0x1	1 wait state	0x2	2 wait states	0x3	3 wait states	0x4	4 wait states	0x5	5 wait states	0x6	6 wait states	0x7	7 wait states	0x8-0xF	reserved
0x0	0 wait states																					
0x1	1 wait state																					
0x2	2 wait states																					
0x3	3 wait states																					
0x4	4 wait states																					
0x5	5 wait states																					
0x6	6 wait states																					
0x7	7 wait states																					
0x8-0xF	reserved																					
15:10	reserved	RW	0x0	Software should not rely on the value of a reserved bit. To provide compatibility with future products, the value of a reserved bit should be preserved across a read-modify-write operation.																		

Bit/Field	Name	Type	Reset	Description
9:6	FBCHT	RW	0x0	Flash Bank Clock High Time Specifies the length of the flash bank clock high time Value Description 0x0 1/2 system clock period 0x1 1 system clock period 0x2 1.5 system clock periods 0x3 2 system clock periods 0x4 2.5 system clock periods 0x5 3 system clock periods 0x6 3.5 system clock periods 0x7 4 system clock periods 0x8 4.5 system clock periods
5	FBCE	RW	1	Flash Bank Clock Edge Specifies the relationship of flash clock to system clock Value Description 0 Flash clock rising aligns with system clock rising 1 Flash clock rising aligns with system clock falling
4	reserved	RW	1	Software should not rely on the value of a reserved bit. To provide compatibility with future products, the value of a reserved bit should be preserved across a read-modify-write operation.
3:0	FWS	RW	0	Flash Wait State This field specifies the number of wait states inserted. Value Description 0x0 0 wait states 0x1 1 wait state 0x2 2 wait states 0x3 3 wait states 0x4 4 wait states 0x5 5 wait states 0x6 6 wait states 0x7 7 wait states 0x8-0xF reserved

Register 13: Alternate Clock Configuration (ALTCLKCFG), offset 0x138

The **ALTCLKCFG** register specifies the alternate clock source used by many of the peripherals.

Alternate Clock Configuration (ALTCLKCFG)

Base 0x400F.E000

Offset 0x138

Type RW, reset 0x0000.0000

	31	30	29	28	27	26	25	24	23	22	21	20	19	18	17	16
	reserved															
Type	RO	RO	RO	RO	RO	RO	RO	RO	RO	RO	RO	RO	RO	RO	RO	RO
Reset	0	0	0	0	0	0	0	0	0	0	0	0	0	0	0	0
	15	14	13	12	11	10	9	8	7	6	5	4	3	2	1	0
	reserved												ALTCLK			
Type	RO	RO	RO	RO	RO	RO	RO	RO	RO	RO	RO	RO	RW	RW	RW	RW
Reset	0	0	0	0	0	0	0	0	0	0	0	0	0	0	0	0

Bit/Field	Name	Type	Reset	Description
31:4	reserved	RO	0	Software should not rely on the value of a reserved bit. To provide compatibility with future products, the value of a reserved bit should be preserved across a read-modify-write operation.
3:0	ALTCLK	RW	0x0	Alternate Clock Source This provides a clock source of numerous frequencies to the general-purpose timer, SSI, and UART modules. Note that if the Hibernation Real-time Clock Output is selected, the clock source must also be enabled in the Hibernation module.

Value	Description
0x0	PIOSC
0x1-0x2	reserved
0x3	Hibernation Module Real-time clock output (RTCOSC)
0x4	Low-frequency internal oscillator (LFIOSC)
0x5-0x15	reserved

Register 14: Deep Sleep Clock Configuration Register (DSCLKCFG), offset 0x144

The **DSCLKCFG** register specifies the behavior of the clock system while in deep sleep.

Note that the **MOSCDPD** bit not only affects deep-sleep mode, but all other modes as well depending on the value of the bit. Please refer to the following table when programming this bit:

Table 5-13. MOSC Configurations

PWRDN bit	MOSCDPD field	Result
0	0	MOSC is powered ON in run and sleep modes, but is disabled in accidental power down, when the PWRDN bit is set in the MOSCCTL register, or in deep-sleep mode only if it is not the deep-sleep clock source (DSOSCSRC != 0x3).
0	1	MOSC is powered and running in run, sleep and deep-sleep modes.
1	0	MOSC is powered off, and does not run in any mode. Please note, that in this configuration, when the MOSC is disabled, the MOSC must not be chosen as a clock source or indeterminate results occur.
1	1	MOSC runs and does not disable itself in run, sleep, and deep-sleep modes regardless of the fact that the PWRDN bit is set.

Note: The **MOSCDPD** bit has an effect in all modes of operation

Note: If the MOSC is chosen as the Deep-Sleep clock source in the **DSCLKCFG** register, the MOSC must also be configured as the Run and Sleep clock source in the **RSCLKCFG** register prior to entering Deep Sleep. If the **PIOSC**, **LFIOSC**, or Hibernation RTC Module Oscillator (**HIBLFIOSC** or 32-kHz crystal) is configured as the Run and Sleep clock source in the **RSCLKCFG** register, and the MOSC is configured as the Deep-Sleep clock source in the **DSCLKCFG** register, then two outcomes are possible:

- If the **PIOSC** is still powered in Deep Sleep (using the **PIOSCPD** bit in the **DSCLKCFG** register) then the **PIOSC** is utilized as the clock source when entering Deep Sleep and the device enters and exits the Deep-Sleep state normally. The MOSC is not used as the clock source in Deep Sleep.
- If the **PIOSC** has been configured to be powered down in Deep Sleep, then the device can enter the Deep-Sleep state, but cannot exit properly. This situation can be avoided by programming the MOSC as the Run and Sleep clock source in the **RSCLKCFG** register prior to entering Deep Sleep.

Deep Sleep Clock Configuration Register (DSCLKCFG)

Base 0x400F.E000
 Offset 0x144
 Type RW, reset 0x0000.0000

	31	30	29	28	27	26	25	24	23	22	21	20	19	18	17	16		
	PIOSCPD		MOSCDPD		reserved								DSOSCSRC				reserved	
Type	RW	RW	RO	RO	RO	RO	RO	RO	RW	RW	RW	RW	RO	RO	RO	RO		
Reset	0	0	0	0	0	0	0	0	0	0	0	0	0	0	0	0		
	15	14	13	12	11	10	9	8	7	6	5	4	3	2	1	0		
	reserved						DSSYSDIV											
Type	RO	RO	RO	RO	RO	RO	RW	RW	RW	RW	RW	RW	RW	RW	RW	RW		
Reset	0	0	0	0	0	0	0	0	0	0	0	0	0	0	0	0		

Bit/Field	Name	Type	Reset	Description
31	PIOSCPD	RW	0	<p>PIOSC Power Down</p> <p>Value Description</p> <p>0 The PIOSC is active during deep sleep mode.</p> <p>1 The PIOSC is disabled during sleep mode for additional power savings.</p>
30	MOSCDPD	RW	0	<p>MOSC Disable Power Down</p> <p>This bit inhibits the MOSC from automatic or accidental power down. This bit is defined to ensure the MOSC circuit cannot be interrupted in uses where MOSC supplies a clock to the peripherals (for example, Ethernet PHY).</p> <p>Value Description</p> <p>0 During deep-sleep (if DSOSCSRC is not MOSC), accidental power down or when the PWRDWN bit is set in the MOSCCTL register, the MOSC is powered down.</p> <p>1 MOSC is not powered off during automatic or accidental power down.</p> <p>Note: MOSC is also not powered off if DSOSCSRC is programmed to be MOSC.</p> <p>Note: This bit should only be set after software configures the MOSCCTL register. Setting the MOSCDPD bit masks writes to PWRDN bit in the MOSCCTL register.</p>
29:24	reserved	RO	0	Software should not rely on the value of a reserved bit. To provide compatibility with future products, the value of a reserved bit should be preserved across a read-modify-write operation.
23:20	DSOSCSRC	RW	0x0	<p>Deep Sleep Oscillator Source</p> <p>This field specifies the oscillator source that becomes the oscillator clock (OSCCLK) source, which is used when the PLL is bypassed during deep sleep mode.</p> <p>Value Description</p> <p>0x0 PIOSC</p> <p>0x1 reserved</p> <p>0x2 LFIOSC</p> <p>0x3 MOSC</p> <p>0x4 Hibernation Module RTCOSC</p> <p>0x5-0xF reserved</p>
19:10	reserved	RO	0x000	Software should not rely on the value of a reserved bit. To provide compatibility with future products, the value of a reserved bit should be preserved across a read-modify-write operation.

Bit/Field	Name	Type	Reset	Description
9:0	DSSYSDIV	RW	0x0	<p>Deep Sleep Clock Divisor</p> <p>This field specifies the system clock divisor value during deep sleep mode. The clock source selected by <code>DSOSCSRC</code> is divided by <code>DSSYSDIV + 1</code>:</p> $f_{\text{SYSCLK}} = f_{\text{OSCCLK}} / (\text{DSSYSDIV} + 1)$ <p>Note: Values 0x0 and 0x1 should not be used. If Deep-Sleep clock divide by 1 or divide by 2 is desired, the <code>OSYSDIV</code> bit field of the RSCLKCFG register must be configured for the desired Deep-Sleep divider before entering Deep-Sleep. In this case, the <code>Q</code> post-divider bit field in the PLLREQ1 register may need to be adjusted to keep the system clock frequency within the maximum clock frequency before entering Deep-Sleep.</p>

Register 15: Divisor and Source Clock Configuration (DIVSCLK), offset 0x148

The **DIVSCLK** register specifies the source and divisor of the **DIVSCLK** reference clock output. This signal can be used as a clock source to an external device but bears no timing relationship to other signals.

Note: The **DIVSCLK** signal output is not synchronized to the System Clock.

Divisor and Source Clock Configuration (DIVSCLK)

Base 0x400F.E000

Offset 0x148

Type RW, reset 0x0000.0000

	31	30	29	28	27	26	25	24	23	22	21	20	19	18	17	16	
	EN	reserved														SRC	
Type	RW	RO	RO	RO	RO	RO	RO	RO	RO	RO	RO	RO	RO	RO	RO	RW	RW
Reset	0	0	0	0	0	0	0	0	0	0	0	0	0	0	0	0	0
	15	14	13	12	11	10	9	8	7	6	5	4	3	2	1	0	
	reserved								DIV								
Type	RO	RO	RO	RO	RO	RO	RO	RO	RW	RW	RW	RW	RW	RW	RW	RW	
Reset	0	0	0	0	0	0	0	0	0	0	0	0	0	0	0	0	

Bit/Field	Name	Type	Reset	Description
31	EN	RW	0	<p>DIVSCLK Enable</p> <p>This bit enables the generation of the DIVSCLK clock output. It resets to 0 to disable the output thereby reducing initial current/power consumption.</p> <p>Value Description</p> <p>0 The clock output is disabled</p> <p>1 Clock output is enabled.</p>
30:18	reserved	RO	0	Software should not rely on the value of a reserved bit. To provide compatibility with future products, the value of a reserved bit should be preserved across a read-modify-write operation.
17:16	SRC	RW	0	<p>Clock Source</p> <p>Selects the reference clock used to generate the output.</p> <p>Value Description</p> <p>0x0 System Clock</p> <p>0x1 PIOSC</p> <p>0x2 MOSC</p> <p>0x3 reserved</p>
15:8	reserved	RO	0	Software should not rely on the value of a reserved bit. To provide compatibility with future products, the value of a reserved bit should be preserved across a read-modify-write operation.

Bit/Field	Name	Type	Reset	Description										
7:0	DIV	RW	0	<p>Divisor Value</p> <p>This field controls the ratio of the source clock to the output clock. The output clock frequency is equal to the source clock frequency divided by the DIV field value plus 1.</p> <table><thead><tr><th>Value</th><th>Description</th></tr></thead><tbody><tr><td>0x0</td><td>Divided by 1</td></tr><tr><td>0x1</td><td>Divided by 2</td></tr><tr><td>....</td><td>.....</td></tr><tr><td>N</td><td>Divided by N</td></tr></tbody></table>	Value	Description	0x0	Divided by 1	0x1	Divided by 2	N	Divided by N
Value	Description													
0x0	Divided by 1													
0x1	Divided by 2													
....													
N	Divided by N													

Register 16: System Properties (SYSPROP), offset 0x14C

This register provides information on whether certain System Control properties are present on the microcontroller.

System Properties (SYSPROP)

Base 0x400F.E000

Offset 0x14C

Type RO, reset 0x0003.1F31

	31	30	29	28	27	26	25	24	23	22	21	20	19	18	17	16
	reserved														LDOSME	TSPDE
Type	RO	RO	RO	RO	RO	RO	RO	RO	RO	RO	RO	RO	RO	RO	RO	RO
Reset	0	0	0	0	0	0	0	0	0	0	0	0	0	0	1	1
	15	14	13	12	11	10	9	8	7	6	5	4	3	2	1	0
	reserved		PIOSCPDE	SRAMSM	SRAMLPM	reserved	FLASHLPM	reserved		LDOSSEQ	reserved				FPU	
Type	RO	RO	RO	RO	RO	RO	RO	RO	RO	RO	RO	RO	RO	RO	RO	RO
Reset	0	0	0	1	1	1	0	1	0	0	1	0	0	0	0	1

Bit/Field	Name	Type	Reset	Description
31:18	reserved	RO	0x0	Software should not rely on the value of a reserved bit. To provide compatibility with future products, the value of a reserved bit should be preserved across a read-modify-write operation.
17	LDOSME	RO	0x1	LDO Sleep Mode Enable Value Description 0 The <code>LDOSM</code> bit of the <code>DSLPPWRCFG</code> register is ignored. 1 The <code>LDOSM</code> bit of the <code>DSLPPWRCFG</code> register can be set to place the LDO in a low-power mode when the deep sleep state is entered.
16	TSPDE	RO	0x1	Temp Sense Power Down Enable This bit allows the internal temperature sensor in the ADC to be powered off in Deep-Sleep mode. Value Description 0 The <code>TSPD</code> bit of the <code>DSLPPWRCFG</code> register is ignored. 1 The <code>TSPD</code> bit of the <code>DSLPPWRCFG</code> register can be set to power off the temperature sensor in deep sleep mode.
15:13	reserved	RO	0x0	Software should not rely on the value of a reserved bit. To provide compatibility with future products, the value of a reserved bit should be preserved across a read-modify-write operation.
12	PIOSCPDE	RO	0x1	PIOSC Power Down Present This bit determines whether the <code>PIOSCPD</code> bit in the <code>DSCLKCFG</code> register can be set to power down the PIOSC in Deep-Sleep mode. Value Description 0 The status of the <code>PIOSCPD</code> bit is ignored. 1 The <code>PIOSCPD</code> bit can be set to power down the PIOSC in Deep-Sleep mode.

Bit/Field	Name	Type	Reset	Description
11	SRAMSM	RO	0x1	<p>SRAM Sleep/Deep-Sleep Standby Mode Present</p> <p>This bit determines whether the <code>SRAMPM</code> field in the SLPPWRCFG and DSLPPWRCFG registers can be configured to put the SRAM into Standby mode while in Sleep or Deep-Sleep mode.</p> <p>Value Description</p> <p>0 A value of 0x1 in the <code>SRAMPM</code> fields is ignored.</p> <p>1 The <code>SRAMPM</code> fields can be configured to put the SRAM into Standby mode while in Sleep or Deep-Sleep mode.</p>
10	SRAMLPM	RO	0x1	<p>SRAM Sleep/Deep-Sleep Low Power Mode Present</p> <p>This bit determines whether the <code>SRAMPM</code> field in the SLPPWRCFG and DSLPPWRCFG registers can be configured to put the SRAM into Low Power mode while in Sleep or Deep-Sleep mode.</p> <p>Refer to “Sleep Modes” on page 1967 for information regarding wake times from Sleep and Deep-Sleep.</p> <p>Value Description</p> <p>0 A value of 0x3 in the <code>SRAMPM</code> fields is ignored.</p> <p>1 The <code>SRAMPM</code> fields can be configured to put the SRAM into Low Power mode while in Sleep or Deep-Sleep mode.</p>
9	reserved	RO	0	<p>Software should not rely on the value of a reserved bit. To provide compatibility with future products, the value of a reserved bit should be preserved across a read-modify-write operation.</p>
8	FLASHLPM	RO	0x1	<p>Flash Memory Sleep/Deep-Sleep Low Power Mode Present</p> <p>This bit determines whether the <code>FLASHPM</code> field in the SLPPWRCFG and DSLPPWRCFG registers can be configured to put the Flash memory into Low Power mode while in Sleep or Deep-Sleep mode.</p> <p>Refer to “Sleep Modes” on page 1967 for information regarding wake times from Sleep and Deep-Sleep.</p> <p>Value Description</p> <p>0 A value of 0x2 in the <code>FLASHPM</code> fields is ignored.</p> <p>1 The <code>FLASHPM</code> fields can be configured to put the Flash memory into Low Power mode while in Sleep or Deep-Sleep mode.</p>
7:6	reserved	RO	0x0	<p>Software should not rely on the value of a reserved bit. To provide compatibility with future products, the value of a reserved bit should be preserved across a read-modify-write operation.</p>
5	LDOSEQ	RO	0x1	<p>Automatic LDO Sequence Control Present</p> <p>This bit indicates that the ability to sequence the LDO output voltage is available during Sleep and Deep-Sleep modes.</p> <p>Value Description</p> <p>0 Software cannot set the <code>VADJEN</code> bit in the LDOSPCTL and LDODPCTL registers.</p> <p>1 Software can set the <code>VADJEN</code> bit in the LDOSPCTL and LDODPCTL registers.</p>

Bit/Field	Name	Type	Reset	Description
4:1	reserved	RO	0	Software should not rely on the value of a reserved bit. To provide compatibility with future products, the value of a reserved bit should be preserved across a read-modify-write operation.
0	FPU	RO	0x1	FPU Present This bit indicates if the FPU is present in the Cortex-M4 core.
				Value Description
				0 FPU is not present.
				1 FPU is present.

Register 17: Precision Internal Oscillator Calibration (PIOSCCAL), offset 0x150

This register provides the ability to update or recalibrate the precision internal oscillator. Note that a 32.768-kHz oscillator must be used as the Hibernation module clock source for the user to be able to calibrate the PIOSC.

Precision Internal Oscillator Calibration (PIOSCCAL)

Base 0x400F.E000
 Offset 0x150
 Type RW, reset 0x0000.0000

	31	30	29	28	27	26	25	24	23	22	21	20	19	18	17	16
	UTEN	reserved														
Type	RW	RO	RO	RO	RO	RO	RO	RO	RO	RO	RO	RO	RO	RO	RO	RO
Reset	0	0	0	0	0	0	0	0	0	0	0	0	0	0	0	0
	15	14	13	12	11	10	9	8	7	6	5	4	3	2	1	0
	reserved						CAL	UPDATE	reserved	UT						
Type	RO	RO	RO	RO	RO	RO	RW	RW	RO	RW	RW	RW	RW	RW	RW	RW
Reset	0	0	0	0	0	0	0	0	0	0	0	0	0	0	0	0

Bit/Field	Name	Type	Reset	Description
31	UTEN	RW	0	Use User Trim Value Value Description 0 The factory calibration value is used for an update trim operation. 1 The trim value in bits[6:0] of this register are used for any update trim operation.
30:10	reserved	RO	0x0000	Software should not rely on the value of a reserved bit. To provide compatibility with future products, the value of a reserved bit should be preserved across a read-modify-write operation.
9	CAL	RW	0	Start Calibration Value Description 0 No action. 1 Starts a new calibration of the PIOSC. Results are in the PIOSCSTAT register. The resulting trim value from the operation is active in the PIOSC after the calibration completes. The result overrides any previous update trim operation whether the calibration passes or fails. This bit is auto-cleared after it is set.
8	UPDATE	RW	0	Update Trim Value Description 0 No action. 1 Updates the PIOSC trim value with the UT bit or the DT bit in the PIOSCSTAT register. Used with UTEN . This bit is auto-cleared after the update.
7	reserved	RO	0	Software should not rely on the value of a reserved bit. To provide compatibility with future products, the value of a reserved bit should be preserved across a read-modify-write operation.

Bit/Field	Name	Type	Reset	Description
6:0	UT	RW	0x0	User Trim Value User trim value that can be loaded into the PIOSC.

Register 18: Precision Internal Oscillator Statistics (PIOSCSTAT), offset 0x154

This register provides the user information on the PIOSC calibration. Note that a 32.768-kHz oscillator must be used as the Hibernation module clock source for the user to be able to calibrate the PIOSC.

Precision Internal Oscillator Statistics (PIOSCSTAT)

Base 0x400F.E000
 Offset 0x154
 Type RO, reset 0x0040.0040

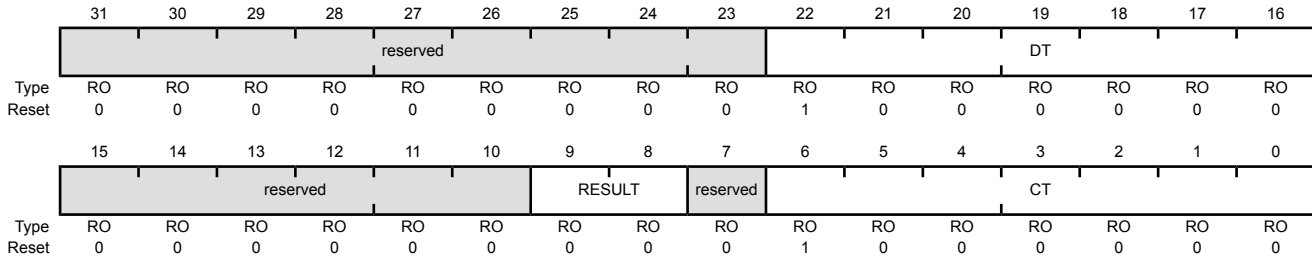

Bit/Field	Name	Type	Reset	Description
31:23	reserved	RO	0x00	Software should not rely on the value of a reserved bit. To provide compatibility with future products, the value of a reserved bit should be preserved across a read-modify-write operation.
22:16	DT	RO	0x40	Default Trim Value This field contains the default trim value. This value is loaded into the PIOSC after every full power-up.
15:10	reserved	RO	0x0	Software should not rely on the value of a reserved bit. To provide compatibility with future products, the value of a reserved bit should be preserved across a read-modify-write operation.
9:8	RESULT	RO	0	Calibration Result Value Description 0x0 Calibration has not been attempted. 0x1 The last calibration operation completed to meet 1% accuracy. 0x2 The last calibration operation failed to meet 1% accuracy. 0x3 Reserved
7	reserved	RO	0	Software should not rely on the value of a reserved bit. To provide compatibility with future products, the value of a reserved bit should be preserved across a read-modify-write operation.
6:0	CT	RO	0x40	Calibration Trim Value This field contains the trim value from the last calibration operation. After factory calibration CT and DT are the same.

Register 19: PLL Frequency 0 (PLLREQ0), offset 0x160

This register always contains the variables used to configure the PLL. If the PLL is reprogrammed, it must go through a relock sequence which is defined by the parameter T_{READY} in Table 30-16 on page 1959. When controlling this register directly, software must change this value while the PLL is powered down. Writes to **PLLREQ0** are delayed from affecting the PLL until the **RSCLKCFG** register **NEWFREQ** bit is written with a 1.

The PLL frequency can be calculated using the following equation:

$$f_{VCO} = (f_{IN} * MDIV)$$

where

$$f_{IN} = f_{XTAL}/(Q+1)(N+1) \text{ or } f_{PIOSC}/(Q+1)(N+1)$$

$$MDIV = MINT + (MFRAC / 1024)$$

The Q and N values are programmed in the **PLLREQ1** register. Note that to reduce jitter, **MFRAC** should be programmed to 0x0.

PLL Frequency 0 (PLLREQ0)

Base 0x400F.E000

Offset 0x160

Type RW, reset 0x0000.0000

	31	30	29	28	27	26	25	24	23	22	21	20	19	18	17	16
	reserved								PLL PWR	reserved			MFRAC			
Type	RO	RO	RO	RO	RO	RO	RO	RO	RW	RO	RO	RO	RW	RW	RW	RW
Reset	0	0	0	0	0	0	0	0	0	0	0	0	0	0	0	0
	15	14	13	12	11	10	9	8	7	6	5	4	3	2	1	0
	MFRAC						MINT									
Type	RW	RW	RW	RW	RW	RW	RW	RW	RW	RW	RW	RW	RW	RW	RW	RW
Reset	0	0	0	0	0	0	0	0	0	0	0	0	0	0	0	0

Bit/Field	Name	Type	Reset	Description
31:24	reserved	RO	0x000	Software should not rely on the value of a reserved bit. To provide compatibility with future products, the value of a reserved bit should be preserved across a read-modify-write operation.
23	PLL PWR	RW	0	PLL Power This bit controls power to the PLL. If set, the PLL power is applied and the PLL will oscillate based on the values in the PLLREQ0 and PLLREQ1 registers.
22:20	reserved	RO	0x0	Software should not rely on the value of a reserved bit. To provide compatibility with future products, the value of a reserved bit should be preserved across a read-modify-write operation.
19:10	MFRAC	RW	0	PLL M Fractional Value
9:0	MINT	RW	0x00	PLL M Integer Value This field contains the integer value of the PLL M value.

Register 20: PLL Frequency 1 (PLLREQ1), offset 0x164

This register always contains the current Q and N values presented to the system PLL. If the PLL is reconfigured, it must go through a relock sequence which takes about 128 PIOSC clocks. When controlling this register directly, software must change this value while the PLL is powered down. Writes to **PLLREQ0** are delayed from affecting the PLL until the **RSCLKCFG** register **NEWFREQ** bit is written with a 1.

The **MINT** and **MFRAC** fields are present in the **PLLREQ0** register.

PLL Frequency 1 (PLLREQ1)

Base 0x400F.E000
 Offset 0x164
 Type RW, reset 0x0000.0000

	31	30	29	28	27	26	25	24	23	22	21	20	19	18	17	16
	reserved															
Type	RO	RO	RO	RO	RO	RO	RO	RO	RO	RO	RO	RO	RO	RO	RO	RO
Reset	0	0	0	0	0	0	0	0	0	0	0	0	0	0	0	0
	15	14	13	12	11	10	9	8	7	6	5	4	3	2	1	0
	reserved			Q					reserved			N				
Type	RO	RO	RO	RW	RW	RW	RW	RW	RO	RO	RO	RW	RW	RW	RW	RW
Reset	0	0	0	0	0	0	0	0	0	0	0	0	0	0	0	0

Bit/Field	Name	Type	Reset	Description
31:13	reserved	RO	0x0000.0	Software should not rely on the value of a reserved bit. To provide compatibility with future products, the value of a reserved bit should be preserved across a read-modify-write operation.
12:8	Q	RW	0x0	PLL Q Value This field contains the PLL Q value.
7:5	reserved	RO	0x0	Software should not rely on the value of a reserved bit. To provide compatibility with future products, the value of a reserved bit should be preserved across a read-modify-write operation.
4:0	N	RW	0x0	PLL N Value This field contains the PLL N value.

Register 21: PLL Status (PLLSTAT), offset 0x168

This register shows the direct status of the PLL lock.

PLL Status (PLLSTAT)

Base 0x400F.E000

Offset 0x168

Type RO, reset 0x0000.0000

	31	30	29	28	27	26	25	24	23	22	21	20	19	18	17	16
	reserved															
Type	RO	RO	RO	RO	RO	RO	RO	RO	RO	RO	RO	RO	RO	RO	RO	RO
Reset	0	0	0	0	0	0	0	0	0	0	0	0	0	0	0	0
	15	14	13	12	11	10	9	8	7	6	5	4	3	2	1	0
	reserved															LOCK
Type	RO	RO	RO	RO	RO	RO	RO	RO	RO	RO	RO	RO	RO	RO	RO	RO
Reset	0	0	0	0	0	0	0	0	0	0	0	0	0	0	0	0

Bit/Field	Name	Type	Reset	Description
31:1	reserved	RO	0x0000.000	Software should not rely on the value of a reserved bit. To provide compatibility with future products, the value of a reserved bit should be preserved across a read-modify-write operation.
0	LOCK	RO	0x0	PLL Lock
				Value Description
				0 The PLL is unpowered or is not yet locked.
				1 The PLL powered and locked.

Register 22: Sleep Power Configuration (SLPPWRCFG), offset 0x188

This register provides configuration information for the power control of the SRAM and Flash memory while in Sleep mode.

Sleep Power Configuration (SLPPWRCFG)

Base 0x400F.E000
 Offset 0x188
 Type RW, reset 0x0000.0000

	31	30	29	28	27	26	25	24	23	22	21	20	19	18	17	16
	reserved															
Type	RO	RO	RO	RO	RO	RO	RO	RO	RO	RO	RO	RO	RO	RO	RO	RO
Reset	0	0	0	0	0	0	0	0	0	0	0	0	0	0	0	0
	15	14	13	12	11	10	9	8	7	6	5	4	3	2	1	0
	reserved										FLASHPM		reserved		SRAMPM	
Type	RO	RO	RO	RO	RO	RO	RO	RO	RO	RO	RW	RW	RO	RO	RW	RW
Reset	0	0	0	0	0	0	0	0	0	0	0	0	0	0	0	0

Bit/Field	Name	Type	Reset	Description
31:6	reserved	RO	0x0000.00	Software should not rely on the value of a reserved bit. To provide compatibility with future products, the value of a reserved bit should be preserved across a read-modify-write operation.
5:4	FLASHPM	RW	0x0	Flash Power Modes Value Description 0x0 Active Mode Flash memory is not placed in a lower power mode. This mode provides the fastest time to sleep and wakeup but the highest power consumption while the microcontroller is in Sleep mode. 0x1 Reserved 0x2 Low Power Mode Flash memory is placed in low power mode. This mode provides the lowers power consumption but requires more time to come out of Sleep mode. 0x3 Reserved
3:2	reserved	RO	0x0	Software should not rely on the value of a reserved bit. To provide compatibility with future products, the value of a reserved bit should be preserved across a read-modify-write operation.

Bit/Field	Name	Type	Reset	Description
1:0	SRAMPM	RW	0x0	<p>SRAM Power Modes</p> <p>This field controls the low power modes of the on-chip SRAM , including the USB SRAM while the microcontroller is in Sleep mode.</p> <p>Value Description</p> <p>0x0 Active Mode SRAM is not placed in a lower power mode. This mode provides the fastest time to sleep and wakeup but the highest power consumption while the microcontroller is in Sleep mode.</p> <p>0x1 Standby Mode SRAM is placed in standby mode while in Sleep mode.</p> <p>0x2 Reserved</p> <p>0x3 Low Power Mode SRAM is placed in low power mode. This mode provides the slowest time to sleep and wakeup but the lowest power consumption while in Sleep mode.</p>

Register 23: Deep-Sleep Power Configuration (DSLPPWRCFG), offset 0x18C

This register provides configuration information for the power control of the SRAM and Flashmemory while in Deep-Sleep mode.

Deep-Sleep Power Configuration (DSLPPWRCFG)

Base 0x400F.E000
 Offset 0x18C
 Type RW, reset 0x0000.0000

	31	30	29	28	27	26	25	24	23	22	21	20	19	18	17	16
	reserved															
Type	RO	RO	RO	RO	RO	RO	RO	RO	RO	RO	RO	RO	RO	RO	RO	RO
Reset	0	0	0	0	0	0	0	0	0	0	0	0	0	0	0	0
	15	14	13	12	11	10	9	8	7	6	5	4	3	2	1	0
	reserved						LDOSM	TSPD	reserved			FLASHPM	reserved		SRAMPM	
Type	RO	RO	RO	RO	RO	RO	RW	RW	RO	RO	RW	RW	RO	RO	RW	RW
Reset	0	0	0	0	0	0	0	0	0	0	0	0	0	0	0	0

Bit/Field	Name	Type	Reset	Description
31:10	reserved	RO	0x0000.00	Software should not rely on the value of a reserved bit. To provide compatibility with future products, the value of a reserved bit should be preserved across a read-modify-write operation.
9	LDOSM	RW	0	LDO Sleep Mode Value Description 0 LDO is disabled in sleep-mode. 1 LDO is placed in a low power mode when deep sleep mode is entered.
8	TSPD	RW	0	Temperature Sense Power Down This bit controls low power mode for the internal temperature sensor in the ADC. Value Description 0 Temperature sensor in the ADC is disabled in sleep-mode. 1 The internal temperature sensor in the ADC is placed in a low power mode when deep sleep mode is entered.
7:6	reserved	RO	0x0	Software should not rely on the value of a reserved bit. To provide compatibility with future products, the value of a reserved bit should be preserved across a read-modify-write operation.

Bit/Field	Name	Type	Reset	Description
5:4	FLASHPM	RW	0x0	<p>Flash Power Modes</p> <p>This field enables the Flash to be placed in a Low Power Mode. Refer to “Sleep Modes” on page 1967 for information regarding wake times from Sleep and Deep-Sleep.</p> <p>If using the LFIOSC as the Deep-Sleep clock source, FLASHPM = 0x2 must be used. If FLASHPM = 0x0 and the LFIOSC is used, current could be higher and could vary.</p> <p>Value Description</p> <p>0x0 Active Mode Flash memory is not placed in a lower power mode. This mode provides the fastest time to sleep and wakeup but the highest power consumption while the microcontroller is in Deep-Sleep mode.</p> <p>0x1 Reserved</p> <p>0x2 Low Power Mode Flash memory is placed in low power mode. This mode provides the lowers power consumption but requires more time to come out of Deep-Sleep mode.</p> <p>0x3 Reserved</p>
3:2	reserved	RO	0x0	Software should not rely on the value of a reserved bit. To provide compatibility with future products, the value of a reserved bit should be preserved across a read-modify-write operation.
1:0	SRAMPM	RW	0x0	<p>SRAM Power Modes</p> <p>This field controls the low power modes of the on-chip SRAM , including the USB SRAM while the microcontroller is in Deep-Sleep mode. Refer to “Sleep Modes” on page 1967 for information regarding wake times from Sleep and Deep-Sleep.</p> <p>Value Description</p> <p>0x0 Active Mode SRAM is not placed in a lower power mode. This mode provides the fastest time to sleep and wakeup but the highest power consumption while the microcontroller is in Deep-Sleep mode.</p> <p>0x1 Standby Mode SRAM is place in standby mode while in Deep-Sleep mode.</p> <p>0x2 Reserved</p> <p>0x3 Low Power Mode SRAM is placed in low power mode. This mode provides the slowest time to sleep and wakeup but the lowest power consumption while in Deep-Sleep mode.</p>

Register 24: Non-Volatile Memory Information (NVMSTAT), offset 0x1A0

This register is predefined by the part and can be used to verify features.

Non-Volatile Memory Information (NVMSTAT)

Base 0x400F.E000

Offset 0x1A0

Type RO, reset 0x0000.0001

	31	30	29	28	27	26	25	24	23	22	21	20	19	18	17	16
	reserved															
Type	RO	RO	RO	RO	RO	RO	RO	RO	RO	RO	RO	RO	RO	RO	RO	RO
Reset	0	0	0	0	0	0	0	0	0	0	0	0	0	0	0	0
	15	14	13	12	11	10	9	8	7	6	5	4	3	2	1	0
	reserved															FWB
Type	RO	RO	RO	RO	RO	RO	RO	RO	RO	RO	RO	RO	RO	RO	RO	RO
Reset	0	0	0	0	0	0	0	0	0	0	0	0	0	0	0	1

Bit/Field	Name	Type	Reset	Description
31:1	reserved	RO	0	Software should not rely on the value of a reserved bit. To provide compatibility with future products, the value of a reserved bit should be preserved across a read-modify-write operation.
0	FWB	RO	0x1	32 Word Flash Write Buffer Available When set, indicates that the 32 word Flash memory write buffer feature is available.

Register 25: LDO Sleep Power Control (LDOSPCTL), offset 0x1B4

This register specifies the LDO output voltage in Sleep mode. This register should be configured while in Run Mode. If the `VADJEN` bit is set, writes can be made to the `VLDO` field within the provided encodings. The following table shows the maximum clock frequencies with respect to LDO Voltage.

Table 5-14. Maximum System Clock and PIOSC Frequency with Respect to LDO Voltage

Operating Voltage (LDO)	Maximum System Clock Frequency	PIOSC
1.2	120 MHz	16 MHz
0.9	30 MHz	16 MHz

LDO Sleep Power Control (LDOSPCTL)

Base 0x400F.E000

Offset 0x1B4

Type RW, reset 0x0000.0018

	31	30	29	28	27	26	25	24	23	22	21	20	19	18	17	16
	VADJEN	reserved														
Type	RW	RO	RO	RO	RO	RO	RO	RO	RO	RO	RO	RO	RO	RO	RO	RO
Reset	0	0	0	0	0	0	0	0	0	0	0	0	0	0	0	0
	15	14	13	12	11	10	9	8	7	6	5	4	3	2	1	0
	reserved								VLDO							
Type	RO	RO	RO	RO	RO	RO	RO	RO	RW	RW	RW	RW	RW	RW	RW	RW
Reset	0	0	0	0	0	0	0	0	0	0	0	1	1	0	0	0

Bit/Field	Name	Type	Reset	Description
31	VADJEN	RW	0	<p>Voltage Adjust Enable</p> <p>This bit enables the value of the <code>VLDO</code> field to be used to specify the output voltage of the LDO in Sleep mode.</p> <p>Value Description</p> <p>0 The LDO output voltage is set to the factory default value in Sleep mode. The value of the <code>VLDO</code> field does not affect the LDO operation.</p> <p>1 The LDO output value in Sleep mode is configured by the value in the <code>VLDO</code> field.</p>
30:8	reserved	RO	0x000.00	Software should not rely on the value of a reserved bit. To provide compatibility with future products, the value of a reserved bit should be preserved across a read-modify-write operation.

Bit/Field	Name	Type	Reset	Description																		
7:0	VLDO	RW	0x18	LDO Output Voltage This field provides program control of the LDO output voltage in Sleep mode. The value of the field is only used for the LDO voltage when the <code>VADJEN</code> bit is set. <table><thead><tr><th>Value</th><th>Description</th></tr></thead><tbody><tr><td>0x12</td><td>0.90 V</td></tr><tr><td>0x13</td><td>0.95 V</td></tr><tr><td>0x14</td><td>1.00 V</td></tr><tr><td>0x15</td><td>1.05 V</td></tr><tr><td>0x16</td><td>1.10 V</td></tr><tr><td>0x17</td><td>1.15 V</td></tr><tr><td>0x18</td><td>1.20 V</td></tr><tr><td>0x19 - 0xFF</td><td>reserved</td></tr></tbody></table> Note: When using the USB module, the LDO must be configured to 1.2 V.	Value	Description	0x12	0.90 V	0x13	0.95 V	0x14	1.00 V	0x15	1.05 V	0x16	1.10 V	0x17	1.15 V	0x18	1.20 V	0x19 - 0xFF	reserved
Value	Description																					
0x12	0.90 V																					
0x13	0.95 V																					
0x14	1.00 V																					
0x15	1.05 V																					
0x16	1.10 V																					
0x17	1.15 V																					
0x18	1.20 V																					
0x19 - 0xFF	reserved																					

Register 26: LDO Sleep Power Calibration (LDOSPCAL), offset 0x1B8

This register provides factory determined values that are recommended for the VLDO field in the LDOSPCTL register while in Sleep mode. The reset value of this register cannot be determined until the product has been characterized.

LDO Sleep Power Calibration (LDOSPCAL)

Base 0x400F.E000

Offset 0x1B8

Type RO, reset 0x0000.1818

	31	30	29	28	27	26	25	24	23	22	21	20	19	18	17	16
	reserved															
Type	RO	RO	RO	RO	RO	RO	RO	RO	RO	RO	RO	RO	RO	RO	RO	RO
Reset	0	0	0	0	0	0	0	0	0	0	0	0	0	0	0	0
	15	14	13	12	11	10	9	8	7	6	5	4	3	2	1	0
	WITHPLL								NOPLL							
Type	RO	RO	RO	RO	RO	RO	RO	RO	RO	RO	RO	RO	RO	RO	RO	RO
Reset	0	0	0	1	1	0	0	0	0	0	0	1	1	0	0	0

Bit/Field	Name	Type	Reset	Description
31:16	reserved	RO	0x0	Software should not rely on the value of a reserved bit. To provide compatibility with future products, the value of a reserved bit should be preserved across a read-modify-write operation.
15:8	WITHPLL	RO	0x18	Sleep with PLL The value in this field is the suggested value for the VLDO field in the LDOSPCTL register when using the PLL. This value provides the lowest recommended LDO output voltage for use with the PLL at the maximum specified value.
7:0	NOPLL	RO	0x18	Sleep without PLL The value in this field is the suggested value for the VLDO field in the LDOSPCTL register when not using the PLL. This value provides the lowest recommended LDO output voltage for use without the PLL.

Register 27: LDO Deep-Sleep Power Control (LDODPCTL), offset 0x1BC

This register specifies the LDO output voltage in Sleep mode. This register should be configured while in Run Mode. If the `VADJEN` bit is set, writes can be made to the `VLDO` field within the provided encodings. The following table shows the maximum clock frequencies with respect to LDO Voltage.

Table 5-15. Maximum System Clock and PIOSC Frequency with Respect to LDO Voltage

Operating Voltage (LDO)	Maximum System Clock Frequency	PIOSC
1.2	120 MHz	16 MHz
0.9	30 MHz	16 MHz

LDO Deep-Sleep Power Control (LDODPCTL)

Base 0x400F.E000
 Offset 0x1BC
 Type RW, reset 0x0000.0012

	31	30	29	28	27	26	25	24	23	22	21	20	19	18	17	16
	VADJEN	reserved														
Type	RW	RO	RO	RO	RO	RO	RO	RO	RO	RO	RO	RO	RO	RO	RO	RO
Reset	0	0	0	0	0	0	0	0	0	0	0	0	0	0	0	0
	15	14	13	12	11	10	9	8	7	6	5	4	3	2	1	0
	reserved								VLDO							
Type	RO	RO	RO	RO	RO	RO	RO	RO	RW	RW	RW	RW	RW	RW	RW	RW
Reset	0	0	0	0	0	0	0	0	0	0	0	1	0	0	1	0

Bit/Field	Name	Type	Reset	Description
31	VADJEN	RW	0	<p>Voltage Adjust Enable</p> <p>This bit enables the value of the <code>VLDO</code> field to be used to specify the output voltage of the LDO in Deep-Sleep mode.</p> <p>Value Description</p> <p>0 The LDO output voltage is set to the factory default value in Deep-Sleep mode. The value of the <code>VLDO</code> field does not affect the LDO operation.</p> <p>1 The LDO output value in Deep-Sleep mode is configured by the value in the <code>VLDO</code> field.</p>
30:8	reserved	RO	0x000.00	Software should not rely on the value of a reserved bit. To provide compatibility with future products, the value of a reserved bit should be preserved across a read-modify-write operation.

Bit/Field	Name	Type	Reset	Description																		
7:0	VLDO	RW	0x12	LDO Output Voltage This field provides program control of the LDO output voltage in Deep-Sleep mode. The value of the field is only used for the LDO voltage when the <code>VADJEN</code> bit is set.																		
				<table><thead><tr><th>Value</th><th>Description</th></tr></thead><tbody><tr><td>0x12</td><td>0.90 V</td></tr><tr><td>0x13</td><td>0.95 V</td></tr><tr><td>0x14</td><td>1.00 V</td></tr><tr><td>0x15</td><td>1.05 V</td></tr><tr><td>0x16</td><td>1.10 V</td></tr><tr><td>0x17</td><td>1.15 V</td></tr><tr><td>0x18</td><td>1.20 V</td></tr><tr><td>0x19 - 0xFF</td><td>reserved</td></tr></tbody></table>	Value	Description	0x12	0.90 V	0x13	0.95 V	0x14	1.00 V	0x15	1.05 V	0x16	1.10 V	0x17	1.15 V	0x18	1.20 V	0x19 - 0xFF	reserved
Value	Description																					
0x12	0.90 V																					
0x13	0.95 V																					
0x14	1.00 V																					
0x15	1.05 V																					
0x16	1.10 V																					
0x17	1.15 V																					
0x18	1.20 V																					
0x19 - 0xFF	reserved																					

Register 28: LDO Deep-Sleep Power Calibration (LDODPCAL), offset 0x1C0

This register provides factory determined values that are recommended for the VLDO field in the LDODPCTL register while in Deep-Sleep mode. The reset value of this register cannot be determined until the product has been characterized.

LDO Deep-Sleep Power Calibration (LDODPCAL)

Base 0x400F.E000
 Offset 0x1C0
 Type RO, reset 0x0000.1212

	31	30	29	28	27	26	25	24	23	22	21	20	19	18	17	16
	reserved															
Type	RO	RO	RO	RO	RO	RO	RO	RO	RO	RO	RO	RO	RO	RO	RO	RO
Reset	0	0	0	0	0	0	0	0	0	0	0	0	0	0	0	0
	15	14	13	12	11	10	9	8	7	6	5	4	3	2	1	0
	NOPLL								30KHZ							
Type	RO	RO	RO	RO	RO	RO	RO	RO	RO	RO	RO	RO	RO	RO	RO	RO
Reset	0	0	0	1	0	0	1	0	0	0	0	1	0	0	1	0

Bit/Field	Name	Type	Reset	Description
31:16	reserved	RO	0x0	Software should not rely on the value of a reserved bit. To provide compatibility with future products, the value of a reserved bit should be preserved across a read-modify-write operation.
15:8	NOPLL	RO	0x12	Deep-Sleep without PLL The value in this field is the suggested value for the VLDO field in the LDODPCTL register when not using the PLL. This value provides the lowest recommended LDO output voltage for use with the system clock.
7:0	30KHZ	RO	0x12	Deep-Sleep with IOSC The value in this field is the suggested value for the VLDO field in the LDODPCTL register when not using the PLL. This value provides the lowest recommended LDO output voltage for use with the low-frequency internal oscillator.

Register 29: Sleep / Deep-Sleep Power Mode Status (SDPMST), offset 0x1CC

This register provides status information on the Sleep and Deep-Sleep power modes as well as some real time status that can be viewed by a debugger or the core if it is running. These events do not trigger an interrupt and are meant to provide information that can help tune software for power management. The status register gets written at the beginning of every Dynamic Power Management event request with the results of any error checking. There is no mechanism to clear the bits; they are overwritten on the next event. The LDOUA, FLASHLP, LOWPWR, PRACT bits provide real time data and there are no events to register that information.

Sleep / Deep-Sleep Power Mode Status (SDPMST)

Base 0x400F.E000

Offset 0x1CC

Type RO, reset 0x0000.0000

	31	30	29	28	27	26	25	24	23	22	21	20	19	18	17	16
	reserved												LDOUA	FLASHLP	LOWPWR	PRACT
Type	RO	RO	RO	RO	RO	RO	RO	RO	RO	RO	RO	RO	RO	RO	RO	RO
Reset	0	0	0	0	0	0	0	0	0	0	0	0	0	0	0	0
	15	14	13	12	11	10	9	8	7	6	5	4	3	2	1	0
	reserved								PPDW	LMAXERR	reserved	LSMINERR	LDMINERR	PPDERR	FPDERR	SPDERR
Type	RO	RO	RO	RO	RO	RO	RO	RO	RO	RO	RO	RO	RO	RO	RO	RO
Reset	0	0	0	0	0	0	0	0	0	0	0	0	0	0	0	0

Bit/Field	Name	Type	Reset	Description
31:20	reserved	RO	0x000	Software should not rely on the value of a reserved bit. To provide compatibility with future products, the value of a reserved bit should be preserved across a read-modify-write operation.
19	LDOUA	RO	0	LDO Update Active Value Description 0 The LDO voltage level is not changing. 1 The LDO voltage level is changing.
18	FLASHLP	RO	0	Flash Memory in Low Power State Value Description 0 The Flash memory is currently in the active state. 1 The Flash memory is currently in the low power state as programmed in the SLPPWRCFG or DSLPPWRCFG register.
17	LOWPWR	RO	0	Sleep or Deep-Sleep Mode Value Description 0 The microcontroller is currently in Run mode. 1 The microcontroller is currently in Sleep or Deep-Sleep mode and is waiting for an interrupt or is in the process of powering up. The status of this bit is not affected by the power state of the Flash memory or SRAM.

Bit/Field	Name	Type	Reset	Description
16	PRACT	RO	0	<p>Sleep or Deep-Sleep Power Request Active</p> <p>Value Description</p> <p>0 A power request is not active.</p> <p>1 The microcontroller is currently in Deep-Sleep mode or is in Sleep mode and a request to put the SRAM and/or Flash memory into a lower power mode is currently active as configured by the SLPPWRCFG register.</p>
15:8	reserved	RO	0x00	Software should not rely on the value of a reserved bit. To provide compatibility with future products, the value of a reserved bit should be preserved across a read-modify-write operation.
7	PPDW	RO	0	<p>PIOSC Power Down Request Warning</p> <p>Value Description</p> <p>0 No error.</p> <p>1 This bit indicates that the PIOSC was not powered off even though the PIOSCPD bit was set in the DSLCLKCFG register because the PIOSC was in use by a peripheral.</p>
6	LMAXERR	RO	0	<p>VLDO Value Above Maximum Error</p> <p>Value Description</p> <p>0 No error.</p> <p>1 An error has occurred because software has requested that the LDO voltage be above the maximum value allowed using the VLDO bit in the LDOSPCTL, or LDODPCTL register. In this situation, the LDO is set to the factory default value.</p>
5	reserved	RO	0	Software should not rely on the value of a reserved bit. To provide compatibility with future products, the value of a reserved bit should be preserved across a read-modify-write operation.
4	LSMINERR	RO	0	<p>VLDO Value Below Minimum Error in Sleep Mode</p> <p>Value Description</p> <p>0 No error.</p> <p>1 An error has occurred because software has requested that the LDO voltage be below the minimum value allowed using the VLDO bit in the LDOSPCTL register. In this situation, the LDO voltage is not changed when entering Sleep mode.</p>

Bit/Field	Name	Type	Reset	Description
3	LDMINERR	RO	0	<p>VLDO Value Below Minimum Error in Deep-Sleep Mode</p> <p>Value Description</p> <p>0 No error.</p> <p>1 An error has occurred because software has requested that the LDO voltage be below the minimum value allowed using the VLDO bit in the LDODPCTL register.</p> <p>In this situation, the LDO voltage is not changed when entering Deep-Sleep mode.</p>
2	PPDERR	RO	0	<p>PIOSC Power Down Request Error</p> <p>Value Description</p> <p>0 No error.</p> <p>1 An error has occurred because software has requested that the PIOSC be powered down during Deep-Sleep and it is not possible to power down the PIOSC.</p> <p>In this situation, the PIOSC is not powered down when entering Deep-Sleep mode.</p>
1	FPDERR	RO	0	<p>Flash Memory Power Down Request Error</p> <p>Value Description</p> <p>0 No error.</p> <p>1 An error has occurred because software has requested a Flash memory power down mode that is not available using the FLASHPM field in the SLPPWRCFG or the DSLPPWRCFG register.</p>
0	SPDERR	RO	0	<p>SRAM Power Down Request Error</p> <p>Value Description</p> <p>0 No error.</p> <p>1 An error has occurred because software has requested an SRAM power down mode that is not available using the SRAMP field in the SLPPWRCFG or the DSLPPWRCFG register.</p>

Register 30: Reset Behavior Control Register (RESBEHAVCTL), offset 0x1D8

The Reset Behavior Control Register contains system management controls.

The **RESBEHAVCTL** register effect occurs immediately when the register is changed. The next power-on reset sequence returns the reset value.

If any bit field below is set to 0x3 when a reset occurs, a simulated POR will be generated and the appropriate reset cause will be set in the **Reset Cause (RESC)** register. During a simulated POR, registers are reloaded and the bootloader is executed. If a full POR is initiated the POR bit in the **RESC** register will be set and all other bits will be cleared.

Reset Behavior Control Register (RESBEHAVCTL)

Base 0x400F.E000
 Offset 0x1D8
 Type RW, reset 0xFFFF.FFFF

	31	30	29	28	27	26	25	24	23	22	21	20	19	18	17	16
	reserved															
Type	RO	RO	RO	RO	RO	RO	RO	RO	RO	RO	RO	RO	RO	RO	RO	RO
Reset	1	1	1	1	1	1	1	1	1	1	1	1	1	1	1	1
	15	14	13	12	11	10	9	8	7	6	5	4	3	2	1	0
	reserved								WDOG1		WDOG0		BOR		EXTRES	
Type	RO	RO	RO	RO	RO	RO	RO	RO	RW	RW	RW	RW	RW	RW	RW	RW
Reset	1	1	1	1	1	1	1	1	1	1	1	1	1	1	1	1

Bit/Field	Name	Type	Reset	Description
31:8	reserved	RO	0xFFFF.FF	Software should not rely on the value of a reserved bit. To provide compatibility with future products, the value of a reserved bit should be preserved across a read-modify-write operation.
7:6	WDOG1	RW	0x3	Watchdog 1 Reset Operation Value Description 0x0 - 0x1 Reserved. Default operation is performed. 0x2 Watchdog 1 issues a system reset. 0x3 Watchdog 1 issues a simulated POR sequence (default).
5:4	WDOG0	RW	0x3	Watchdog 0 Reset Operation Value Description 0x0 - 0x1 Reserved. Default operation is performed. 0x2 Watchdog 0 issues a system reset. 0x3 Watchdog 0 issues a simulated POR sequence (default).

Bit/Field	Name	Type	Reset	Description								
3:2	BOR	RW	0x3	<p>BOR Reset operation</p> <p>This field defines operation of BOR when the USER has defined the BOR operation to be a reset.</p> <p>Note: If the BOR operation is defined as an interrupt, this setting has no effect.</p> <table border="1"> <thead> <tr> <th>Value</th> <th>Description</th> </tr> </thead> <tbody> <tr> <td>0x0 - 0x1</td> <td>Reserved. Default operation is performed.</td> </tr> <tr> <td>0x2</td> <td>Brown Out Reset issues system reset.</td> </tr> <tr> <td>0x3</td> <td>Brown Out Reset issues a simulated POR sequence (default).</td> </tr> </tbody> </table>	Value	Description	0x0 - 0x1	Reserved. Default operation is performed.	0x2	Brown Out Reset issues system reset.	0x3	Brown Out Reset issues a simulated POR sequence (default).
Value	Description											
0x0 - 0x1	Reserved. Default operation is performed.											
0x2	Brown Out Reset issues system reset.											
0x3	Brown Out Reset issues a simulated POR sequence (default).											
1:0	EXTRES	RW	0x3	<p>External $\overline{\text{RST}}$ Pin Operation</p> <table border="1"> <thead> <tr> <th>Value</th> <th>Description</th> </tr> </thead> <tbody> <tr> <td>0x0 - 0x1</td> <td>Reserved. Default operation is performed.</td> </tr> <tr> <td>0x2</td> <td>External $\overline{\text{RST}}$ assertion issues a system reset.</td> </tr> <tr> <td>0x3</td> <td>External $\overline{\text{RST}}$ assertion issues a simulated POR sequence (default).</td> </tr> </tbody> </table>	Value	Description	0x0 - 0x1	Reserved. Default operation is performed.	0x2	External $\overline{\text{RST}}$ assertion issues a system reset.	0x3	External $\overline{\text{RST}}$ assertion issues a simulated POR sequence (default).
Value	Description											
0x0 - 0x1	Reserved. Default operation is performed.											
0x2	External $\overline{\text{RST}}$ assertion issues a system reset.											
0x3	External $\overline{\text{RST}}$ assertion issues a simulated POR sequence (default).											

Register 31: Hardware System Service Request (HSSR), offset 0x1F4

The **HSSR** register is used to control system configuration functions, such as Return-to-Factory settings. A write to the **HSSR** register stores a command descriptor pointer (**CDOFF**) value if the **KEY** field is correct (0xCA). A successful write to this register also initiates a system reset. The initialization process executes before examining the **HSSR** register and processing the command. This register can only be accessed in privilege mode. Refer to “Hardware System Service Request” on page 252 for more information on how to use the **HSSR** register.

Hardware System Service Request (HSSR)

Base 0x400F.E000
 Offset 0x1F4
 Type RW, reset 0x0000.0000

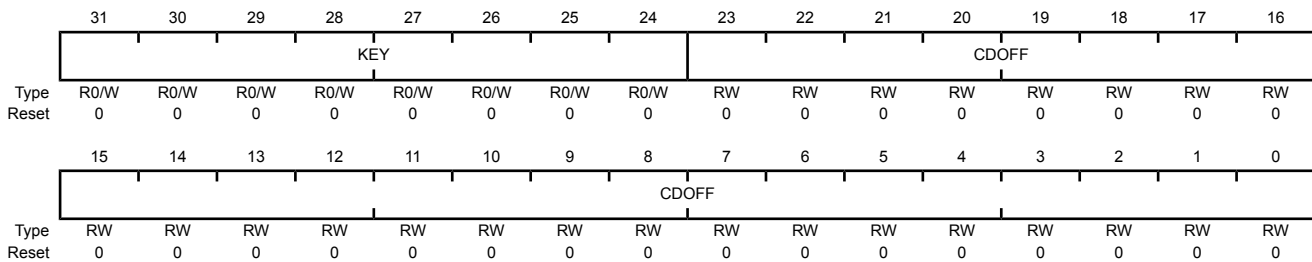

Bit/Field	Name	Type	Reset	Description
31:24	KEY	R0/W	0	Write Key When read, this field returns zero. When written, this field must contain the value of 0xCA in order to register the CDOFF field and initiate a HSSR request. Writes with KEY values other than 0xCA are ignored.
23:0	CDOFF	RW	0	Command Descriptor Pointer This field contains either the status result from the previous HSSR request, or it contains a (word-aligned) memory address where the command descriptor is located. If CDOFF = 0x00.0000, it indicates there is no request and no processing is performed. If CDOFF = 0xFF.FFFF, it indicates that the previous request through HSSR did not complete due to an error. Otherwise, CDOFF contains the offset for a data structure in SRAM.

Register 32: USB Power Domain Status (USBPDS), offset 0x280

This register provides the status of power to the USB SRAM memory array.

Note: If the **USBMPC** register's **PWRCTL** field is set to 0x3 and the power domain to the USB is turned off by writing a 0 to the **P0** bit of the **PCUSB** register, then the SRAM memory goes into retention and the **MEMSTAT** field of the **USBPDS** register reads as 0x1 (retention).

USB Power Domain Status (USBPDS)

Base 0x400F.E000

Offset 0x280

Type RO, reset 0x0000.003F

	31	30	29	28	27	26	25	24	23	22	21	20	19	18	17	16	
	reserved																
Type	RO	RO	RO	RO	RO	RO	RO	RO	RO	RO	RO	RO	RO	RO	RO	RO	
Reset	0	0	0	0	0	0	0	0	0	0	0	0	0	0	0	0	
	15	14	13	12	11	10	9	8	7	6	5	4	3	2	1	0	
	reserved											reserved		MEMSTAT		PWRSTAT	
Type	RO	RO	RO	RO	RO	RO	RO	RO	RO	RO	RO	RO	RO	RO	RO	RO	
Reset	0	0	0	0	0	0	0	0	0	0	1	1	1	1	1	1	

Bit/Field	Name	Type	Reset	Description
31:6	reserved	RO	0	Software should not rely on the value of a reserved bit. To provide compatibility with future products, the value of a reserved bit should be preserved across a read-modify-write operation.
5:4	reserved	RO	0x3	Software should not rely on the value of a reserved bit. To provide compatibility with future products, the value of a reserved bit should be preserved across a read-modify-write operation.
3:2	MEMSTAT	RO	0x3	Memory Array Power Status Displays status of USB SRAM memory
				Value Description
				0x0 Array OFF
				0x1 SRAM Retention
				0x2 Reserved
				0x3 Array On
1:0	PWRSTAT	RO	0x3	Power Domain Status
				Value Description
				0x0 OFF
				0x1-0x2 Reserved
				0x3 ON

Register 33: USB Memory Power Control (USBMPC), offset 0x284

This register provides power control to the peripheral memory array.

Note: If the **USBMPC** register's **PWRCTL** field is set to 0x3 and the power domain to the USB is turned off by writing a 0 to the **P0** bit of the **PCUSB** register, then the SRAM memory goes into retention and the **MEMSTAT** field of the **USBPDS** register reads as 0x1 (retention).

USB Memory Power Control (USBMPC)

Base 0x400F.E000
 Offset 0x284
 Type RW, reset 0x0000.0003

	31	30	29	28	27	26	25	24	23	22	21	20	19	18	17	16
	reserved															
Type	RO	RO	RO	RO	RO	RO	RO	RO	RO	RO	RO	RO	RO	RO	RO	RO
Reset	0	0	0	0	0	0	0	0	0	0	0	0	0	0	0	0
	15	14	13	12	11	10	9	8	7	6	5	4	3	2	1	0
	reserved														PWRCTL	
Type	RO	RO	RO	RO	RO	RO	RO	RO	RO	RO	RO	RO	RO	RO	RW	RW
Reset	0	0	0	0	0	0	0	0	0	0	0	0	0	0	1	1

Bit/Field	Name	Type	Reset	Description
31:2	reserved	RO	0	Software should not rely on the value of a reserved bit. To provide compatibility with future products, the value of a reserved bit should be preserved across a read-modify-write operation.
1:0	PWRCTL	RW	0x3	Memory Array Power Control Allows multiple levels of power control in peripheral's SRAM memory space Value Description 0x0 Array OFF 0x1 SRAM Retention 0x2 Reserved 0x3 Array On

Register 34: Ethernet MAC Power Domain Status (EMACPDS), offset 0x288

This register provides the status of power to the EMAC SRAM memory array.

Note: The EMAC memory array does not support retention and can only be turned ON and OFF. Memory array OFF is supported only when the power domain is off. If the memory array is currently turned on ($PWRCTL = 0x3$) and the power control to the EMAC is subsequently removed by clearing the P0 bit of the **PCEMAC** register, the event causes the memory array to turn off and the **MEMSTAT** bit in the **EMACPDS** register to be 0x0 (array OFF).

Ethernet MAC Power Domain Status (EMACPDS)

Base 0x400F.E000

Offset 0x288

Type RO, reset 0x0000.003F

	31	30	29	28	27	26	25	24	23	22	21	20	19	18	17	16
	reserved															
Type	RO	RO	RO	RO	RO	RO	RO	RO	RO	RO	RO	RO	RO	RO	RO	RO
Reset	0	0	0	0	0	0	0	0	0	0	0	0	0	0	0	0
	15	14	13	12	11	10	9	8	7	6	5	4	3	2	1	0
	reserved										reserved		MEMSTAT		PWRSTAT	
Type	RO	RO	RO	RO	RO	RO	RO	RO	RO	RO	RO	RO	RO	RO	RO	RO
Reset	0	0	0	0	0	0	0	0	0	0	1	1	1	1	1	1

Bit/Field	Name	Type	Reset	Description
31:6	reserved	RO	0	Software should not rely on the value of a reserved bit. To provide compatibility with future products, the value of a reserved bit should be preserved across a read-modify-write operation.
5:4	reserved	RO	0x3	Software should not rely on the value of a reserved bit. To provide compatibility with future products, the value of a reserved bit should be preserved across a read-modify-write operation.
3:2	MEMSTAT	RO	0x3	Memory Array Power Status Displays status of EMAC SRAM memory
				Value Description
				0x0 Array OFF
				0x1-0x2 Reserved
				0x3 Array On
1:0	PWRSTAT	RO	0x3	Power Domain Status
				Value Description
				0x0 OFF
				0x1-0x2 Reserved
				0x3 ON

Register 35: Ethernet MAC Memory Power Control (EMACMPC), offset 0x28C

This register provides power control to the peripheral memory array.

Note: The EMAC memory array does not support retention and can only be turned ON and OFF. Memory array OFF is supported only when the power domain is off. If the memory array is turned on ($PWRCTL = 0x3$) and the power control to the EMAC is removed by clearing the $P0$ bit of the **PCEMAC** register, the memory array is turned off and the $MEMSTAT$ bit in the **EMACPDS** register is 0x0.

Ethernet MAC Memory Power Control (EMACMPC)

Base 0x400F.E000
 Offset 0x28C
 Type RW, reset 0x0000.0003

	31	30	29	28	27	26	25	24	23	22	21	20	19	18	17	16
	reserved															
Type	RO	RO	RO	RO	RO	RO	RO	RO	RO	RO	RO	RO	RO	RO	RO	RO
Reset	0	0	0	0	0	0	0	0	0	0	0	0	0	0	0	0
	15	14	13	12	11	10	9	8	7	6	5	4	3	2	1	0
	reserved														PWRCTL	
Type	RO	RO	RO	RO	RO	RO	RO	RO	RO	RO	RO	RO	RO	RO	RW	RW
Reset	0	0	0	0	0	0	0	0	0	0	0	0	0	0	1	1

Bit/Field	Name	Type	Reset	Description
31:2	reserved	RO	0	Software should not rely on the value of a reserved bit. To provide compatibility with future products, the value of a reserved bit should be preserved across a read-modify-write operation.
1:0	PWRCTL	RW	0x3	Memory Array Power Control
				Value Description
				0x0 Array OFF
				Note: Array OFF Mode is only supported when the $P0$ bit of the PCEMAC register at offset 0x99C is set to 0.
				0x1-0x2 Reserved
				0x3 Array On

Register 36: CAN 0 Power Domain Status (CAN0PDS), offset 0x298

This register provides the status of power to the CAN0 SRAM memory array.

Note: The CAN0 memory array does not support retention and can only be turned ON and OFF. If the memory array is currently turned on ($PWRCTL = 0x3$) and the power control to the CAN0 is subsequently removed by clearing the P0 bit of the PCCAN register, the event causes the memory array to turn off and the MEMSTAT bit in the CAN0PDS register to be 0x0 (array OFF).

CAN 0 Power Domain Status (CAN0PDS)

Base 0x400F.E000

Offset 0x298

Type RO, reset 0x0000.003F

	31	30	29	28	27	26	25	24	23	22	21	20	19	18	17	16
	reserved															
Type	RO	RO	RO	RO	RO	RO	RO	RO	RO	RO	RO	RO	RO	RO	RO	RO
Reset	0	0	0	0	0	0	0	0	0	0	0	0	0	0	0	0
	15	14	13	12	11	10	9	8	7	6	5	4	3	2	1	0
	reserved										reserved		MEMSTAT		PWRSTAT	
Type	RO	RO	RO	RO	RO	RO	RO	RO	RO	RO	RO	RO	RO	RO	RO	RO
Reset	0	0	0	0	0	0	0	0	0	0	1	1	1	1	1	1

Bit/Field	Name	Type	Reset	Description
31:6	reserved	RO	0	Software should not rely on the value of a reserved bit. To provide compatibility with future products, the value of a reserved bit should be preserved across a read-modify-write operation.
5:4	reserved	RO	0x3	Software should not rely on the value of a reserved bit. To provide compatibility with future products, the value of a reserved bit should be preserved across a read-modify-write operation.
3:2	MEMSTAT	RO	0x3	Memory Array Power Status Displays status of the CAN0 SRAM memory
				Value Description
				0x0 Array OFF
				0x1-0x2 Reserved
				0x3 Array On
1:0	PWRSTAT	RO	0x3	Power Domain Status
				Value Description
				0x0 OFF
				0x1-0x2 Reserved
				0x3 ON

Register 37: CAN 0 Memory Power Control (CAN0MPC), offset 0x29C

This register provides power control to the peripheral memory array.

Note: The CAN0 memory array does not support retention and can only be turned ON and OFF. If the memory array is currently turned ON ($PWRCTL = 0x3$) and the power control to the CAN0 is subsequently removed by clearing the P0 bit of the **PCCAN** register, the event causes the memory array to turn off and the **MEMSTAT** bit in the **CAN0PDS** register to be 0x0 (array OFF).

CAN 0 Memory Power Control (CAN0MPC)

Base 0x400F.E000
 Offset 0x29C
 Type RW, reset 0x0000.0003

	31	30	29	28	27	26	25	24	23	22	21	20	19	18	17	16	
	reserved																
Type	RO	RO	RO	RO	RO	RO	RO	RO	RO	RO	RO	RO	RO	RO	RO	RO	
Reset	0	0	0	0	0	0	0	0	0	0	0	0	0	0	0	0	
	15	14	13	12	11	10	9	8	7	6	5	4	3	2	1	0	
	reserved														PWRCTL		
Type	RO	RO	RO	RO	RO	RO	RO	RO	RO	RO	RO	RO	RO	RO	RO	RW	RW
Reset	0	0	0	0	0	0	0	0	0	0	0	0	0	0	0	1	1

Bit/Field	Name	Type	Reset	Description
31:2	reserved	RO	0	Software should not rely on the value of a reserved bit. To provide compatibility with future products, the value of a reserved bit should be preserved across a read-modify-write operation.
1:0	PWRCTL	RW	0x3	Memory Array Power Control Allows multiple levels of power control in peripheral's SRAM memory space
				Value Description
				0x0 Array OFF
				0x1-0x2 Reserved
				0x3 Array On

Register 38: CAN 1 Power Domain Status (CAN1PDS), offset 0x2A0

This register provides the status of power to the CAN 1 SRAM memory array.

Note: The CAN1 memory array does not support retention and can only be turned ON and OFF. If the memory array is currently turned on ($PWRCTL = 0x3$) and the power control to CAN1 is subsequently removed by clearing the P1 bit of the **PCCAN** register, the event causes the memory array to turn off and the MEMSTAT bit in the **CAN1PDS** register to be 0x0 (array OFF).

CAN 1 Power Domain Status (CAN1PDS)

Base 0x400F.E000
Offset 0x2A0
Type RO, reset 0x0000.003F

	31	30	29	28	27	26	25	24	23	22	21	20	19	18	17	16	
	reserved																
Type	RO	RO	RO	RO	RO	RO	RO	RO	RO	RO	RO	RO	RO	RO	RO	RO	
Reset	0	0	0	0	0	0	0	0	0	0	0	0	0	0	0	0	
	15	14	13	12	11	10	9	8	7	6	5	4	3	2	1	0	
	reserved											reserved		MEMSTAT		PWRSTAT	
Type	RO	RO	RO	RO	RO	RO	RO	RO	RO	RO	RO	RO	RO	RO	RO	RO	
Reset	0	0	0	0	0	0	0	0	0	0	0	1	1	1	1	1	

Bit/Field	Name	Type	Reset	Description
31:6	reserved	RO	0	Software should not rely on the value of a reserved bit. To provide compatibility with future products, the value of a reserved bit should be preserved across a read-modify-write operation.
5:4	reserved	RO	0x3	Software should not rely on the value of a reserved bit. To provide compatibility with future products, the value of a reserved bit should be preserved across a read-modify-write operation.
3:2	MEMSTAT	RO	0x3	Memory Array Power Status Displays status of CAN1 SRAM memory
				Value Description
				0x0 Array OFF
				0x1-0x2 Reserved
				0x3 Array On
1:0	PWRSTAT	RO	0x3	Power Domain Status
				Value Description
				0x0 OFF
				0x1-0x2 Reserved
				0x3 ON

Register 39: CAN 1 Memory Power Control (CAN1MPC), offset 0x2A4

This register provides power control to the peripheral memory array.

Note: The CAN1 memory array does not support retention and can only be turned ON and OFF. If the memory array is currently turned on (PWRCTL = 0x3) and the power control to CAN1 is subsequently removed by clearing the P1 bit of the PCCAN register, the event causes the memory array to turn off and the MEMSTAT bit in the CAN1PDS register to be 0x0 (array OFF).

CAN 1 Memory Power Control (CAN1MPC)

Base 0x400F.E000
 Offset 0x2A4
 Type RW, reset 0x0000.0003

	31	30	29	28	27	26	25	24	23	22	21	20	19	18	17	16	
	reserved																
Type	RO	RO	RO	RO	RO	RO	RO	RO	RO	RO	RO	RO	RO	RO	RO	RO	
Reset	0	0	0	0	0	0	0	0	0	0	0	0	0	0	0	0	
	15	14	13	12	11	10	9	8	7	6	5	4	3	2	1	0	
	reserved														PWRCTL		
Type	RO	RO	RO	RO	RO	RO	RO	RO	RO	RO	RO	RO	RO	RO	RO	RW	RW
Reset	0	0	0	0	0	0	0	0	0	0	0	0	0	0	0	1	1

Bit/Field	Name	Type	Reset	Description
31:2	reserved	RO	0x0000.000	Software should not rely on the value of a reserved bit. To provide compatibility with future products, the value of a reserved bit should be preserved across a read-modify-write operation.
1:0	PWRCTL	RW	0x3	Memory Array Power Control Allows multiple levels of power control in peripheral's SRAM memory space
				Value Description
				0x0 Array OFF
				0x1-0x2 Reserved
				0x3 Array On

Register 40: Watchdog Timer Peripheral Present (PPWD), offset 0x300

The **PPWD** register provides software information regarding the watchdog modules.

Important: This register should be used to determine which watchdog timers are implemented on this microcontroller.

Watchdog Timer Peripheral Present (PPWD)

Base 0x400F.E000
Offset 0x300
Type RO, reset 0x0000.0003

	31	30	29	28	27	26	25	24	23	22	21	20	19	18	17	16	
	reserved																
Type	RO	RO	RO	RO	RO	RO	RO	RO	RO	RO	RO	RO	RO	RO	RO	RO	
Reset	0	0	0	0	0	0	0	0	0	0	0	0	0	0	0	0	
	15	14	13	12	11	10	9	8	7	6	5	4	3	2	1	0	
	reserved															P1	P0
Type	RO	RO	RO	RO	RO	RO	RO	RO	RO	RO	RO	RO	RO	RO	RO	RO	RO
Reset	0	0	0	0	0	0	0	0	0	0	0	0	0	0	0	1	1

Bit/Field	Name	Type	Reset	Description
31:2	reserved	RO	0	Software should not rely on the value of a reserved bit. To provide compatibility with future products, the value of a reserved bit should be preserved across a read-modify-write operation.
1	P1	RO	0x1	Watchdog Timer 1 Present Value Description 0 Watchdog module 1 is not present. 1 Watchdog module 1 is present.
0	P0	RO	0x1	Watchdog Timer 0 Present Value Description 0 Watchdog module 0 is not present. 1 Watchdog module 0 is present.

Register 41: 16/32-Bit General-Purpose Timer Peripheral Present (PPTIMER), offset 0x304

The **PPTIMER** register provides software information regarding the 16/32-bit general-purpose timer modules.

Important: This register should be used to determine which timers are implemented on this microcontroller.

16/32-Bit General-Purpose Timer Peripheral Present (PPTIMER)

Base 0x400F.E000
 Offset 0x304
 Type RO, reset 0x0000.00FF

	31	30	29	28	27	26	25	24	23	22	21	20	19	18	17	16
	reserved															
Type	RO	RO	RO	RO	RO	RO	RO	RO	RO	RO	RO	RO	RO	RO	RO	RO
Reset	0	0	0	0	0	0	0	0	0	0	0	0	0	0	0	0
	15	14	13	12	11	10	9	8	7	6	5	4	3	2	1	0
	reserved								P7	P6	P5	P4	P3	P2	P1	P0
Type	RO	RO	RO	RO	RO	RO	RO	RO	RO	RO	RO	RO	RO	RO	RO	RO
Reset	0	0	0	0	0	0	0	0	1	1	1	1	1	1	1	1

Bit/Field	Name	Type	Reset	Description
31:8	reserved	RO	0	Software should not rely on the value of a reserved bit. To provide compatibility with future products, the value of a reserved bit should be preserved across a read-modify-write operation.
7	P7	RO	0x1	16/32-Bit General-Purpose Timer 7 Present Value Description 0 16/32-bit general-purpose timer module 7 is not present. 1 16/32-bit general-purpose timer module 7 is present.
6	P6	RO	0x1	16/32-Bit General-Purpose Timer 6 Present Value Description 0 16/32-bit general-purpose timer module 6 is not present. 1 16/32-bit general-purpose timer module 6 is present.
5	P5	RO	0x1	16/32-Bit General-Purpose Timer 5 Present Value Description 0 16/32-bit general-purpose timer module 5 is not present. 1 16/32-bit general-purpose timer module 5 is present.
4	P4	RO	0x1	16/32-Bit General-Purpose Timer 4 Present Value Description 0 16/32-bit general-purpose timer module 4 is not present. 1 16/32-bit general-purpose timer module 4 is present.

Bit/Field	Name	Type	Reset	Description
3	P3	RO	0x1	16/32-Bit General-Purpose Timer 3 Present Value Description 0 16/32-bit general-purpose timer module 3 is not present. 1 16/32-bit general-purpose timer module 3 is present.
2	P2	RO	0x1	16/32-Bit General-Purpose Timer 2 Present Value Description 0 16/32-bit general-purpose timer module 2 is not present. 1 16/32-bit general-purpose timer module 2 is present.
1	P1	RO	0x1	16/32-Bit General-Purpose Timer 1 Present Value Description 0 16/32-bit general-purpose timer module 1 is not present. 1 16/32-bit general-purpose timer module 1 is present.
0	P0	RO	0x1	16/32-Bit General-Purpose Timer 0 Present Value Description 0 16/32-bit general-purpose timer module 0 is not present. 1 16/32-bit general-purpose timer module 0 is present.

Register 42: General-Purpose Input/Output Peripheral Present (PPGPIO), offset 0x308

The **PPGPIO** register provides software information regarding the general-purpose input/output modules.

Important: This register should be used to determine which GPIO ports are implemented on this microcontroller.

General-Purpose Input/Output Peripheral Present (PPGPIO)

Base 0x400F.E000
 Offset 0x308
 Type RO, reset 0x0000.7FFF

	31	30	29	28	27	26	25	24	23	22	21	20	19	18	17	16
	reserved															
Type	RO	RO	RO	RO	RO	RO	RO	RO	RO	RO	RO	RO	RO	RO	RO	RO
Reset	0	0	0	0	0	0	0	0	0	0	0	0	0	0	0	0
	15	14	13	12	11	10	9	8	7	6	5	4	3	2	1	0
	reserved	P14	P13	P12	P11	P10	P9	P8	P7	P6	P5	P4	P3	P2	P1	P0
Type	RO	RO	RO	RO	RO	RO	RO	RO	RO	RO	RO	RO	RO	RO	RO	RO
Reset	0	1	1	1	1	1	1	1	1	1	1	1	1	1	1	1

Bit/Field	Name	Type	Reset	Description
31:15	reserved	RO	0	Software should not rely on the value of a reserved bit. To provide compatibility with future products, the value of a reserved bit should be preserved across a read-modify-write operation.
14	P14	RO	0x1	GPIO Port Q Present Value Description 0 GPIO Port Q is not present. 1 GPIO Port Q is present.
13	P13	RO	0x1	GPIO Port P Present Value Description 0 GPIO Port P is not present. 1 GPIO Port P is present.
12	P12	RO	0x1	GPIO Port N Present Value Description 0 GPIO Port N is not present. 1 GPIO Port N is present.
11	P11	RO	0x1	GPIO Port M Present Value Description 0 GPIO Port M is not present. 1 GPIO Port M is present.

Bit/Field	Name	Type	Reset	Description
10	P10	RO	0x1	GPIO Port L Present Value Description 0 GPIO Port L is not present. 1 GPIO Port L is present.
9	P9	RO	0x1	GPIO Port K Present Value Description 0 GPIO Port K is not present. 1 GPIO Port K is present.
8	P8	RO	0x1	GPIO Port J Present Value Description 0 GPIO Port J is not present. 1 GPIO Port J is present.
7	P7	RO	0x1	GPIO Port H Present Value Description 0 GPIO Port H is not present. 1 GPIO Port H is present.
6	P6	RO	0x1	GPIO Port G Present Value Description 0 GPIO Port G is not present. 1 GPIO Port G is present.
5	P5	RO	0x1	GPIO Port F Present Value Description 0 GPIO Port F is not present. 1 GPIO Port F is present.
4	P4	RO	0x1	GPIO Port E Present Value Description 0 GPIO Port E is not present. 1 GPIO Port E is present.

Bit/Field	Name	Type	Reset	Description
3	P3	RO	0x1	GPIO Port D Present Value Description 0 GPIO Port D is not present. 1 GPIO Port D is present.
2	P2	RO	0x1	GPIO Port C Present Value Description 0 GPIO Port C is not present. 1 GPIO Port C is present.
1	P1	RO	0x1	GPIO Port B Present Value Description 0 GPIO Port B is not present. 1 GPIO Port B is present.
0	P0	RO	0x1	GPIO Port A Present Value Description 0 GPIO Port A is not present. 1 GPIO Port A is present.

Register 43: Micro Direct Memory Access Peripheral Present (PPDMA), offset 0x30C

The **PPDMA** register provides software information regarding the μ DMA module.

Important: This register should be used to determine if the μ DMA module is implemented on this microcontroller.

Micro Direct Memory Access Peripheral Present (PPDMA)

Base 0x400F.E000

Offset 0x30C

Type RO, reset 0x0000.0001

	31	30	29	28	27	26	25	24	23	22	21	20	19	18	17	16
	reserved															
Type	RO	RO	RO	RO	RO	RO	RO	RO	RO	RO	RO	RO	RO	RO	RO	RO
Reset	0	0	0	0	0	0	0	0	0	0	0	0	0	0	0	0
	15	14	13	12	11	10	9	8	7	6	5	4	3	2	1	0
	reserved															P0
Type	RO	RO	RO	RO	RO	RO	RO	RO	RO	RO	RO	RO	RO	RO	RO	RO
Reset	0	0	0	0	0	0	0	0	0	0	0	0	0	0	0	1

Bit/Field	Name	Type	Reset	Description
31:1	reserved	RO	0	Software should not rely on the value of a reserved bit. To provide compatibility with future products, the value of a reserved bit should be preserved across a read-modify-write operation.
0	P0	RO	0x1	μ DMA Module Present
				Value Description
			0	μ DMA module is not present.
			1	μ DMA module is present.

Register 44: EPI Peripheral Present (PPEPI), offset 0x310

The PPEPI register provides software information regarding the EPI module.

Important: This register should be used to determine if the EPI module is implemented on this microcontroller.

EPI Peripheral Present (PPEPI)

Base 0x400F.E000

Offset 0x310

Type RO, reset 0x0000.0001

	31	30	29	28	27	26	25	24	23	22	21	20	19	18	17	16
	reserved															
Type	RO	RO	RO	RO	RO	RO	RO	RO	RO	RO	RO	RO	RO	RO	RO	RO
Reset	0	0	0	0	0	0	0	0	0	0	0	0	0	0	0	0
	15	14	13	12	11	10	9	8	7	6	5	4	3	2	1	0
	reserved															P0
Type	RO	RO	RO	RO	RO	RO	RO	RO	RO	RO	RO	RO	RO	RO	RO	RO
Reset	0	0	0	0	0	0	0	0	0	0	0	0	0	0	0	1

Bit/Field	Name	Type	Reset	Description
31:1	reserved	RO	0	Software should not rely on the value of a reserved bit. To provide compatibility with future products, the value of a reserved bit should be preserved across a read-modify-write operation.
0	P0	RO	0x1	EPI Module Present
				Value Description
				0 EPI module is not present.
				1 EPI module is present.

Register 45: Hibernation Peripheral Present (PPHIB), offset 0x314

The **PPHIB** register provides software information regarding the Hibernation module.

Important: This register should be used to determine if the Hibernation module is implemented on this microcontroller.

Hibernation Peripheral Present (PPHIB)

Base 0x400F.E000

Offset 0x314

Type RO, reset 0x0000.0001

	31	30	29	28	27	26	25	24	23	22	21	20	19	18	17	16
	reserved															
Type	RO	RO	RO	RO	RO	RO	RO	RO	RO	RO	RO	RO	RO	RO	RO	RO
Reset	0	0	0	0	0	0	0	0	0	0	0	0	0	0	0	0
	15	14	13	12	11	10	9	8	7	6	5	4	3	2	1	0
	reserved															P0
Type	RO	RO	RO	RO	RO	RO	RO	RO	RO	RO	RO	RO	RO	RO	RO	RO
Reset	0	0	0	0	0	0	0	0	0	0	0	0	0	0	0	1

Bit/Field	Name	Type	Reset	Description
31:1	reserved	RO	0	Software should not rely on the value of a reserved bit. To provide compatibility with future products, the value of a reserved bit should be preserved across a read-modify-write operation.

0	P0	RO	0x1	Hibernation Module Present
---	----	----	-----	----------------------------

Value Description

0	Hibernation module is not present.
1	Hibernation module is present.

Register 46: Universal Asynchronous Receiver/Transmitter Peripheral Present (PPUART), offset 0x318

The PPUART register provides software information regarding the UART modules.

Important: This register should be used to determine which UART modules are implemented on this microcontroller.

Universal Asynchronous Receiver/Transmitter Peripheral Present (PPUART)

Base 0x400F.E000
 Offset 0x318
 Type RO, reset 0x0000.00FF

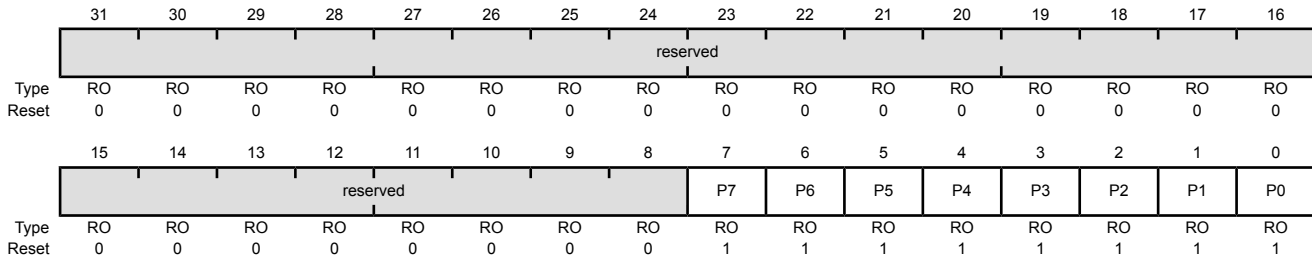

Bit/Field	Name	Type	Reset	Description
31:8	reserved	RO	0	Software should not rely on the value of a reserved bit. To provide compatibility with future products, the value of a reserved bit should be preserved across a read-modify-write operation.
7	P7	RO	0x1	UART Module 7 Present Value Description 0 UART module 7 is not present. 1 UART module 7 is present.
6	P6	RO	0x1	UART Module 6 Present Value Description 0 UART module 6 is not present. 1 UART module 6 is present.
5	P5	RO	0x1	UART Module 5 Present Value Description 0 UART module 5 is not present. 1 UART module 5 is present.
4	P4	RO	0x1	UART Module 4 Present Value Description 0 UART module 4 is not present. 1 UART module 4 is present.

Bit/Field	Name	Type	Reset	Description
3	P3	RO	0x1	UART Module 3 Present Value Description 0 UART module 3 is not present. 1 UART module 3 is present.
2	P2	RO	0x1	UART Module 2 Present Value Description 0 UART module 2 is not present. 1 UART module 2 is present.
1	P1	RO	0x1	UART Module 1 Present Value Description 0 UART module 1 is not present. 1 UART module 1 is present.
0	P0	RO	0x1	UART Module 0 Present Value Description 0 UART module 0 is not present. 1 UART module 0 is present.

Register 47: Synchronous Serial Interface Peripheral Present (PPSSI), offset 0x31C

The **PPSSI** register provides software information regarding the SSI modules.

Important: This register should be used to determine which SSI modules are implemented on this microcontroller. However, to support legacy software, the **DC2** register is available. A read of the **DC2** register correctly identifies if a legacy SSI module is present. Software must use this register to determine if a module that is not supported by the **DC2** register is present.

Synchronous Serial Interface Peripheral Present (PPSSI)

Base 0x400F.E000
 Offset 0x31C
 Type RO, reset 0x0000.000F

	31	30	29	28	27	26	25	24	23	22	21	20	19	18	17	16	
	reserved																
Type	RO	RO	RO	RO	RO	RO	RO	RO	RO	RO	RO	RO	RO	RO	RO	RO	
Reset	0	0	0	0	0	0	0	0	0	0	0	0	0	0	0	0	
	15	14	13	12	11	10	9	8	7	6	5	4	3	2	1	0	
	reserved													P3	P2	P1	P0
Type	RO	RO	RO	RO	RO	RO	RO	RO	RO	RO	RO	RO	RO	RO	RO	RO	
Reset	0	0	0	0	0	0	0	0	0	0	0	0	1	1	1	1	

Bit/Field	Name	Type	Reset	Description
31:4	reserved	RO	0	Software should not rely on the value of a reserved bit. To provide compatibility with future products, the value of a reserved bit should be preserved across a read-modify-write operation.
3	P3	RO	0x1	SSI Module 3 Present Value Description 0 SSI module 3 is not present. 1 SSI module 3 is present.
2	P2	RO	0x1	SSI Module 2 Present Value Description 0 SSI module 2 is not present. 1 SSI module 2 is present.
1	P1	RO	0x1	SSI Module 1 Present Value Description 0 SSI module 1 is not present. 1 SSI module 1 is present.

Bit/Field	Name	Type	Reset	Description
0	P0	RO	0x1	SSI Module 0 Present
				Value Description
				0 SSI module 0 is not present.
				1 SSI module 0 is present.

Register 48: Inter-Integrated Circuit Peripheral Present (PPI2C), offset 0x320

The **PPI2C** register provides software information regarding the I²C modules.

Important: This register should be used to determine which I²C modules are implemented on this microcontroller.

Inter-Integrated Circuit Peripheral Present (PPI2C)

Base 0x400F.E000

Offset 0x320

Type RO, reset 0x0000.03FF

	31	30	29	28	27	26	25	24	23	22	21	20	19	18	17	16	
	reserved																
Type	RO	RO	RO	RO	RO	RO	RO	RO	RO	RO	RO	RO	RO	RO	RO	RO	
Reset	0	0	0	0	0	0	0	0	0	0	0	0	0	0	0	0	
	15	14	13	12	11	10	9	8	7	6	5	4	3	2	1	0	
	reserved							P9	P8	P7	P6	P5	P4	P3	P2	P1	P0
Type	RO	RO	RO	RO	RO	RO	RO	RO	RO	RO	RO	RO	RO	RO	RO	RO	
Reset	0	0	0	0	0	0	1	1	1	1	1	1	1	1	1	1	

Bit/Field	Name	Type	Reset	Description
31:10	reserved	RO	0	Software should not rely on the value of a reserved bit. To provide compatibility with future products, the value of a reserved bit should be preserved across a read-modify-write operation.
9	P9	RO	0x1	I ² C Module 9 Present Value Description 0 I ² C module 9 is not present. 1 I ² C module 9 is present.
8	P8	RO	0x1	I ² C Module 8 Present Value Description 0 I ² C module 8 is not present. 1 I ² C module 8 is present.
7	P7	RO	0x1	I ² C Module 7 Present Value Description 0 I ² C module 7 is not present. 1 I ² C module 7 is present.
6	P6	RO	0x1	I ² C Module 6 Present Value Description 0 I ² C module 6 is not present. 1 I ² C module 6 is present.

Bit/Field	Name	Type	Reset	Description
5	P5	RO	0x1	I ² C Module 5 Present Value Description 0 I ² C module 5 is not present. 1 I ² C module 5 is present.
4	P4	RO	0x1	I ² C Module 4 Present Value Description 0 I ² C module 4 is not present. 1 I ² C module 4 is present.
3	P3	RO	0x1	I ² C Module 3 Present Value Description 0 I ² C module 3 is not present. 1 I ² C module 3 is present.
2	P2	RO	0x1	I ² C Module 2 Present Value Description 0 I ² C module 2 is not present. 1 I ² C module 2 is present.
1	P1	RO	0x1	I ² C Module 1 Present Value Description 0 I ² C module 1 is not present. 1 I ² C module 1 is present.
0	P0	RO	0x1	I ² C Module 0 Present Value Description 0 I ² C module 0 is not present. 1 I ² C module 0 is present.

Register 49: Universal Serial Bus Peripheral Present (PPUSB), offset 0x328

The **PPUSB** register provides software information regarding the USB module.

Important: This register should be used to determine if the USB module is implemented on this microcontroller.

Universal Serial Bus Peripheral Present (PPUSB)

Base 0x400F.E000

Offset 0x328

Type RO, reset 0x0000.0001

	31	30	29	28	27	26	25	24	23	22	21	20	19	18	17	16
	reserved															
Type	RO	RO	RO	RO	RO	RO	RO	RO	RO	RO	RO	RO	RO	RO	RO	RO
Reset	0	0	0	0	0	0	0	0	0	0	0	0	0	0	0	0
	15	14	13	12	11	10	9	8	7	6	5	4	3	2	1	0
	reserved															P0
Type	RO	RO	RO	RO	RO	RO	RO	RO	RO	RO	RO	RO	RO	RO	RO	RO
Reset	0	0	0	0	0	0	0	0	0	0	0	0	0	0	0	1

Bit/Field	Name	Type	Reset	Description
31:1	reserved	RO	0	Software should not rely on the value of a reserved bit. To provide compatibility with future products, the value of a reserved bit should be preserved across a read-modify-write operation.
0	P0	RO	0x1	USB Module Present
				Value Description
				0 USB module is not present.
				1 USB module is present.

Register 50: Ethernet PHY Peripheral Present (PPEPHY), offset 0x330

The **PPEPHY** register provides software information regarding the Ethernet PHY module.

Important: This register should be used to determine if the Ethernet PHY module is implemented on this microcontroller.

Ethernet PHY Peripheral Present (PPEPHY)

Base 0x400F.E000

Offset 0x330

Type RO, reset 0x0000.0001

	31	30	29	28	27	26	25	24	23	22	21	20	19	18	17	16
	reserved															
Type	RO	RO	RO	RO	RO	RO	RO	RO	RO	RO	RO	RO	RO	RO	RO	RO
Reset	0	0	0	0	0	0	0	0	0	0	0	0	0	0	0	0
	15	14	13	12	11	10	9	8	7	6	5	4	3	2	1	0
	reserved															P0
Type	RO	RO	RO	RO	RO	RO	RO	RO	RO	RO	RO	RO	RO	RO	RO	RO
Reset	0	0	0	0	0	0	0	0	0	0	0	0	0	0	0	1

Bit/Field	Name	Type	Reset	Description
31:1	reserved	RO	0	Software should not rely on the value of a reserved bit. To provide compatibility with future products, the value of a reserved bit should be preserved across a read-modify-write operation.
0	P0	RO	0x1	Ethernet PHY Module Present
				Value Description
			0	Ethernet PHY module is not present.
			1	Ethernet PHY module is present.

Register 51: Controller Area Network Peripheral Present (PPCAN), offset 0x334

The **PPCAN** register provides software information regarding the CAN modules.

Important: This register should be used to determine which CAN modules are implemented on this microcontroller.

Controller Area Network Peripheral Present (PPCAN)

Base 0x400F.E000
 Offset 0x334
 Type RO, reset 0x0000.0003

	31	30	29	28	27	26	25	24	23	22	21	20	19	18	17	16	
	reserved																
Type	RO	RO	RO	RO	RO	RO	RO	RO	RO	RO	RO	RO	RO	RO	RO	RO	
Reset	0	0	0	0	0	0	0	0	0	0	0	0	0	0	0	0	
	15	14	13	12	11	10	9	8	7	6	5	4	3	2	1	0	
	reserved															P1	P0
Type	RO	RO	RO	RO	RO	RO	RO	RO	RO	RO	RO	RO	RO	RO	RO	RO	RO
Reset	0	0	0	0	0	0	0	0	0	0	0	0	0	0	0	1	1

Bit/Field	Name	Type	Reset	Description
31:2	reserved	RO	0	Software should not rely on the value of a reserved bit. To provide compatibility with future products, the value of a reserved bit should be preserved across a read-modify-write operation.
1	P1	RO	0x1	CAN Module 1 Present Value Description 0 CAN module 1 is not present. 1 CAN module 1 is present.
0	P0	RO	0x1	CAN Module 0 Present Value Description 0 CAN module 0 is not present. 1 CAN module 0 is present.

Register 52: Analog-to-Digital Converter Peripheral Present (PPADC), offset 0x338

The **PPADC** register provides software information regarding the ADC modules.

Important: This register should be used to determine which ADC modules are implemented on this microcontroller.

Analog-to-Digital Converter Peripheral Present (PPADC)

Base 0x400F.E000

Offset 0x338

Type RO, reset 0x0000.0003

	31	30	29	28	27	26	25	24	23	22	21	20	19	18	17	16	
	reserved																
Type	RO	RO	RO	RO	RO	RO	RO	RO	RO	RO	RO	RO	RO	RO	RO	RO	
Reset	0	0	0	0	0	0	0	0	0	0	0	0	0	0	0	0	
	15	14	13	12	11	10	9	8	7	6	5	4	3	2	1	0	
	reserved															P1	P0
Type	RO	RO	RO	RO	RO	RO	RO	RO	RO	RO	RO	RO	RO	RO	RO	RO	RO
Reset	0	0	0	0	0	0	0	0	0	0	0	0	0	0	1	1	

Bit/Field	Name	Type	Reset	Description
31:2	reserved	RO	0	Software should not rely on the value of a reserved bit. To provide compatibility with future products, the value of a reserved bit should be preserved across a read-modify-write operation.
1	P1	RO	0x1	ADC Module 1 Present Value Description 0 ADC module 1 is not present. 1 ADC module 1 is present.
0	P0	RO	0x1	ADC Module 0 Present Value Description 0 ADC module 0 is not present. 1 ADC module 0 is present.

Register 53: Analog Comparator Peripheral Present (PPACMP), offset 0x33C

The **PPACMP** register provides software information regarding the analog comparator module.

Important: This register should be used to determine if the analog comparator module is implemented on this microcontroller.

Note that the **Analog Comparator Peripheral Properties (ACMPPP)** register indicates how many analog comparator blocks are included in the module.

Analog Comparator Peripheral Present (PPACMP)

Base 0x400F.E000

Offset 0x33C

Type RO, reset 0x0000.0001

	31	30	29	28	27	26	25	24	23	22	21	20	19	18	17	16
	reserved															
Type	RO	RO	RO	RO	RO	RO	RO	RO	RO	RO	RO	RO	RO	RO	RO	RO
Reset	0	0	0	0	0	0	0	0	0	0	0	0	0	0	0	0
	15	14	13	12	11	10	9	8	7	6	5	4	3	2	1	0
	reserved															P0
Type	RO	RO	RO	RO	RO	RO	RO	RO	RO	RO	RO	RO	RO	RO	RO	RO
Reset	0	0	0	0	0	0	0	0	0	0	0	0	0	0	0	1

Bit/Field	Name	Type	Reset	Description
31:1	reserved	RO	0	Software should not rely on the value of a reserved bit. To provide compatibility with future products, the value of a reserved bit should be preserved across a read-modify-write operation.
0	P0	RO	0x1	Analog Comparator Module Present
Value Description				
	0			Analog comparator module is not present.
	1			Analog comparator module is present.

Register 54: Pulse Width Modulator Peripheral Present (PPPWM), offset 0x340

The **PPPWM** register provides software information regarding the PWM modules.

Important: This register should be used to determine which PWM modules are implemented on this microcontroller.

Pulse Width Modulator Peripheral Present (PPPWM)

Base 0x400F.E000

Offset 0x340

Type RO, reset 0x0000.0001

	31	30	29	28	27	26	25	24	23	22	21	20	19	18	17	16
	reserved															
Type	RO	RO	RO	RO	RO	RO	RO	RO	RO	RO	RO	RO	RO	RO	RO	RO
Reset	0	0	0	0	0	0	0	0	0	0	0	0	0	0	0	0
	15	14	13	12	11	10	9	8	7	6	5	4	3	2	1	0
	reserved															P0
Type	RO	RO	RO	RO	RO	RO	RO	RO	RO	RO	RO	RO	RO	RO	RO	RO
Reset	0	0	0	0	0	0	0	0	0	0	0	0	0	0	0	1

Bit/Field	Name	Type	Reset	Description
31:1	reserved	RO	0	Software should not rely on the value of a reserved bit. To provide compatibility with future products, the value of a reserved bit should be preserved across a read-modify-write operation.
0	P0	RO	0x1	PWM Module 0 Present
				Value Description
				0 PWM module 0 is not present.
				1 PWM module 0 is present.

Register 55: Quadrature Encoder Interface Peripheral Present (PPQEI), offset 0x344

The **PPQEI** register provides software information regarding the QEI modules.

Important: This register should be used to determine which QEI modules are implemented on this microcontroller.

Quadrature Encoder Interface Peripheral Present (PPQEI)

Base 0x400F.E000

Offset 0x344

Type RO, reset 0x0000.0001

	31	30	29	28	27	26	25	24	23	22	21	20	19	18	17	16
	reserved															
Type	RO	RO	RO	RO	RO	RO	RO	RO	RO	RO	RO	RO	RO	RO	RO	RO
Reset	0	0	0	0	0	0	0	0	0	0	0	0	0	0	0	0
	15	14	13	12	11	10	9	8	7	6	5	4	3	2	1	0
	reserved															P0
Type	RO	RO	RO	RO	RO	RO	RO	RO	RO	RO	RO	RO	RO	RO	RO	RO
Reset	0	0	0	0	0	0	0	0	0	0	0	0	0	0	0	1

Bit/Field	Name	Type	Reset	Description
31:1	reserved	RO	0	Software should not rely on the value of a reserved bit. To provide compatibility with future products, the value of a reserved bit should be preserved across a read-modify-write operation.
0	P0	RO	0x1	QEI Module 0 Present
				Value Description
				0 QEI module 0 is not present.
				1 QEI module 0 is present.

Register 56: Low Pin Count Interface Peripheral Present (PPLPC), offset 0x348

The **PPLPC** register provides software information regarding the LPC module.

Low Pin Count Interface Peripheral Present (PPLPC)

Base 0x400F.E000

Offset 0x348

Type RO, reset 0x0000.0000

	31	30	29	28	27	26	25	24	23	22	21	20	19	18	17	16
	reserved															
Type	RO	RO	RO	RO	RO	RO	RO	RO	RO	RO	RO	RO	RO	RO	RO	RO
Reset	0	0	0	0	0	0	0	0	0	0	0	0	0	0	0	0
	15	14	13	12	11	10	9	8	7	6	5	4	3	2	1	0
	reserved															P0
Type	RO	RO	RO	RO	RO	RO	RO	RO	RO	RO	RO	RO	RO	RO	RO	RO
Reset	0	0	0	0	0	0	0	0	0	0	0	0	0	0	0	0

Bit/Field	Name	Type	Reset	Description
31:1	reserved	RO	0	Software should not rely on the value of a reserved bit. To provide compatibility with future products, the value of a reserved bit should be preserved across a read-modify-write operation.
0	P0	RO	0x0	LPC Module Present
				Value Description
				0 LPC module is not present.
				1 LPC module is present.

Register 57: Platform Environment Control Interface Peripheral Present (PPPECI), offset 0x350

The **PPPECI** register provides software information regarding the PECEI module.

Platform Environment Control Interface Peripheral Present (PPPECI)

Base 0x400F.E000

Offset 0x350

Type RO, reset 0x0000.0000

	31	30	29	28	27	26	25	24	23	22	21	20	19	18	17	16
	reserved															
Type	RO	RO	RO	RO	RO	RO	RO	RO	RO	RO	RO	RO	RO	RO	RO	RO
Reset	0	0	0	0	0	0	0	0	0	0	0	0	0	0	0	0
	15	14	13	12	11	10	9	8	7	6	5	4	3	2	1	0
	reserved															P0
Type	RO	RO	RO	RO	RO	RO	RO	RO	RO	RO	RO	RO	RO	RO	RO	RO
Reset	0	0	0	0	0	0	0	0	0	0	0	0	0	0	0	0

Bit/Field	Name	Type	Reset	Description
31:1	reserved	RO	0	Software should not rely on the value of a reserved bit. To provide compatibility with future products, the value of a reserved bit should be preserved across a read-modify-write operation.
0	P0	RO	0x0	PECEI Module Present
Value Description				
	0			PECEI module is not present.
	1			PECEI module is present.

Register 58: Fan Control Peripheral Present (PPFAN), offset 0x354

The **PPFAN** register provides software information regarding the FAN module.

Fan Control Peripheral Present (PPFAN)

Base 0x400F.E000

Offset 0x354

Type RO, reset 0x0000.0000

	31	30	29	28	27	26	25	24	23	22	21	20	19	18	17	16
	reserved															
Type	RO	RO	RO	RO	RO	RO	RO	RO	RO	RO	RO	RO	RO	RO	RO	RO
Reset	0	0	0	0	0	0	0	0	0	0	0	0	0	0	0	0
	15	14	13	12	11	10	9	8	7	6	5	4	3	2	1	0
	reserved															P0
Type	RO	RO	RO	RO	RO	RO	RO	RO	RO	RO	RO	RO	RO	RO	RO	RO
Reset	0	0	0	0	0	0	0	0	0	0	0	0	0	0	0	0

Bit/Field	Name	Type	Reset	Description
31:1	reserved	RO	0	Software should not rely on the value of a reserved bit. To provide compatibility with future products, the value of a reserved bit should be preserved across a read-modify-write operation.
0	P0	RO	0x0	FAN Module 0 Present
				Value Description
				0 FAN module is not present.
				1 FAN module is present.

Register 59: EEPROM Peripheral Present (PPEEPROM), offset 0x358

The **PPEEPROM** register provides software information regarding the EEPROM module.

EEPROM Peripheral Present (PPEEPROM)

Base 0x400F.E000

Offset 0x358

Type RO, reset 0x0000.0001

	31	30	29	28	27	26	25	24	23	22	21	20	19	18	17	16
	reserved															
Type	RO	RO	RO	RO	RO	RO	RO	RO	RO	RO	RO	RO	RO	RO	RO	RO
Reset	0	0	0	0	0	0	0	0	0	0	0	0	0	0	0	0
	15	14	13	12	11	10	9	8	7	6	5	4	3	2	1	0
	reserved															P0
Type	RO	RO	RO	RO	RO	RO	RO	RO	RO	RO	RO	RO	RO	RO	RO	RO
Reset	0	0	0	0	0	0	0	0	0	0	0	0	0	0	0	1

Bit/Field	Name	Type	Reset	Description
31:1	reserved	RO	0	Software should not rely on the value of a reserved bit. To provide compatibility with future products, the value of a reserved bit should be preserved across a read-modify-write operation.
0	P0	RO	0x1	EEPROM 0 Module Present
Value Description				
	0			EEPROM module is not present.
	1			EEPROM module is present.

Register 60: 32/64-Bit Wide General-Purpose Timer Peripheral Present (PPWTIMER), offset 0x35C

The **PPWTIMER** register provides software information regarding the 32/64-bit wide general-purpose timer modules.

32/64-Bit Wide General-Purpose Timer Peripheral Present (PPWTIMER)

Base 0x400F.E000

Offset 0x35C

Type RO, reset 0x0000.0000

	31	30	29	28	27	26	25	24	23	22	21	20	19	18	17	16
	reserved															
Type	RO	RO	RO	RO	RO	RO	RO	RO	RO	RO	RO	RO	RO	RO	RO	RO
Reset	0	0	0	0	0	0	0	0	0	0	0	0	0	0	0	0
	15	14	13	12	11	10	9	8	7	6	5	4	3	2	1	0
	reserved															P0
Type	RO	RO	RO	RO	RO	RO	RO	RO	RO	RO	RO	RO	RO	RO	RO	RO
Reset	0	0	0	0	0	0	0	0	0	0	0	0	0	0	0	0

Bit/Field	Name	Type	Reset	Description
31:1	reserved	RO	0	Software should not rely on the value of a reserved bit. To provide compatibility with future products, the value of a reserved bit should be preserved across a read-modify-write operation.
0	P0	RO	0x0	32/64-Bit Wide General-Purpose Timer 0 Present
				Value Description
			0	32/64-bit wide general-purpose timer module 0 is not present.
			1	32/64-bit wide general-purpose timer module 0 is present.

Register 61: Remote Temperature Sensor Peripheral Present (PPRTS), offset 0x370

The **PPRTS** register provides software information regarding the Remote Temperature Sensor (RTS) module.

Important: This register should be used to determine which RTS modules are implemented on this microcontroller.

Remote Temperature Sensor Peripheral Present (PPRTS)

Base 0x400F.E000
 Offset 0x370
 Type RO, reset 0x0000.0000

	31	30	29	28	27	26	25	24	23	22	21	20	19	18	17	16
	reserved															
Type	RO	RO	RO	RO	RO	RO	RO	RO	RO	RO	RO	RO	RO	RO	RO	RO
Reset	0	0	0	0	0	0	0	0	0	0	0	0	0	0	0	0
	15	14	13	12	11	10	9	8	7	6	5	4	3	2	1	0
	reserved															P0
Type	RO	RO	RO	RO	RO	RO	RO	RO	RO	RO	RO	RO	RO	RO	RO	RO
Reset	0	0	0	0	0	0	0	0	0	0	0	0	0	0	0	0

Bit/Field	Name	Type	Reset	Description
31:1	reserved	RO	0	Software should not rely on the value of a reserved bit. To provide compatibility with future products, the value of a reserved bit should be preserved across a read-modify-write operation.
0	P0	RO	0x0	RTS Module Present
				Value Description
				0 RTS module is not present.
				1 RTS module is present.

Register 62: CRC and Cryptographic Modules Peripheral Present (PPCCM), offset 0x374

The **PPCCM** register provides software information regarding the CRC and Cryptographic Modules (AES, DES, and SHA).

Important: This register should be used to determine if the CRC and Cryptographic Modules (AES, DES, SHA/MD5) are implemented on this microcontroller.

CRC and Cryptographic Modules Peripheral Present (PPCCM)

Base 0x400F.E000

Offset 0x374

Type RO, reset 0x0000.0001

	31	30	29	28	27	26	25	24	23	22	21	20	19	18	17	16
	reserved															
Type	RO	RO	RO	RO	RO	RO	RO	RO	RO	RO	RO	RO	RO	RO	RO	RO
Reset	0	0	0	0	0	0	0	0	0	0	0	0	0	0	0	0
	15	14	13	12	11	10	9	8	7	6	5	4	3	2	1	0
	reserved															P0
Type	RO	RO	RO	RO	RO	RO	RO	RO	RO	RO	RO	RO	RO	RO	RO	RO
Reset	0	0	0	0	0	0	0	0	0	0	0	0	0	0	0	1

Bit/Field	Name	Type	Reset	Description
31:1	reserved	RO	0	Software should not rely on the value of a reserved bit. To provide compatibility with future products, the value of a reserved bit should be preserved across a read-modify-write operation.
0	P0	RO	0x1	CRC and Cryptographic Modules Present
				Value Description
			0	The CRC, AES, DES, and SHA/MD modules are not present.
			1	The CRC, AES, DES, and SHA/MD modules are present.

Register 63: LCD Peripheral Present (PPLCD), offset 0x390

The **PPLCD** register provides software information regarding the LCD module.

Important: This register should be used to determine if an LCD controller is implemented on this microcontroller.

LCD Peripheral Present (PPLCD)

Base 0x400F.E000
 Offset 0x390
 Type RO, reset 0x0000.0000

	31	30	29	28	27	26	25	24	23	22	21	20	19	18	17	16
	reserved															
Type	RO	RO	RO	RO	RO	RO	RO	RO	RO	RO	RO	RO	RO	RO	RO	RO
Reset	0	0	0	0	0	0	0	0	0	0	0	0	0	0	0	0
	15	14	13	12	11	10	9	8	7	6	5	4	3	2	1	0
	reserved															P0
Type	RO	RO	RO	RO	RO	RO	RO	RO	RO	RO	RO	RO	RO	RO	RO	RO
Reset	0	0	0	0	0	0	0	0	0	0	0	0	0	0	0	0

Bit/Field	Name	Type	Reset	Description
31:1	reserved	RO	0	Software should not rely on the value of a reserved bit. To provide compatibility with future products, the value of a reserved bit should be preserved across a read-modify-write operation.
0	P0	RO	0x0	LCD Module Present
				Value Description
				0 LCD module is not present.
				1 LCD module is present.

Register 64: 1-Wire Peripheral Present (PPOWIRE), offset 0x398

The **PPOWIRE** register provides software information regarding the 1-Wire module.

Important: This register should be used to determine which 1-Wire modules are implemented on this microcontroller.

1-Wire Peripheral Present (PPOWIRE)

Base 0x400F.E000

Offset 0x398

Type RO, reset 0x0000.0000

	31	30	29	28	27	26	25	24	23	22	21	20	19	18	17	16
	reserved															
Type	RO	RO	RO	RO	RO	RO	RO	RO	RO	RO	RO	RO	RO	RO	RO	RO
Reset	0	0	0	0	0	0	0	0	0	0	0	0	0	0	0	0
	15	14	13	12	11	10	9	8	7	6	5	4	3	2	1	0
	reserved															
Type	RO	RO	RO	RO	RO	RO	RO	RO	RO	RO	RO	RO	RO	RO	RO	P0
Reset	0	0	0	0	0	0	0	0	0	0	0	0	0	0	0	0

Bit/Field	Name	Type	Reset	Description
31:1	reserved	RO	0	Software should not rely on the value of a reserved bit. To provide compatibility with future products, the value of a reserved bit should be preserved across a read-modify-write operation.
0	P0	RO	0x0	1-Wire Module Present
				Value Description
				0 1-Wire module is not present.
				1 1-Wire module is present.

Register 65: Ethernet MAC Peripheral Present (PPEMAC), offset 0x39C

The **PPEMAC** register provides software information regarding the Ethernet controller module.

Important: This register should be used to determine which Ethernet controller modules are implemented on this microcontroller.

Ethernet MAC Peripheral Present (PPEMAC)

Base 0x400F.E000

Offset 0x39C

Type RO, reset 0x0000.0001

	31	30	29	28	27	26	25	24	23	22	21	20	19	18	17	16
	reserved															
Type	RO	RO	RO	RO	RO	RO	RO	RO	RO	RO	RO	RO	RO	RO	RO	RO
Reset	0	0	0	0	0	0	0	0	0	0	0	0	0	0	0	0
	15	14	13	12	11	10	9	8	7	6	5	4	3	2	1	0
	reserved															P0
Type	RO	RO	RO	RO	RO	RO	RO	RO	RO	RO	RO	RO	RO	RO	RO	RO
Reset	0	0	0	0	0	0	0	0	0	0	0	0	0	0	0	1

Bit/Field	Name	Type	Reset	Description
31:1	reserved	RO	0	Software should not rely on the value of a reserved bit. To provide compatibility with future products, the value of a reserved bit should be preserved across a read-modify-write operation.
0	P0	RO	0x1	Ethernet Controller Module Present
				Value Description
			0	Ethernet Controller MAC module is not present.
			1	Ethernet Controller MAC module is present.

Register 66: Power Regulator Bus Peripheral Present (PPPRB), offset 0x3A0

The **PPPRB** register provides software information regarding the Power Regulator Bus module.

Important: This register should be used to determine which Power Regulator Bus modules are implemented on this microcontroller.

Power Regulator Bus Peripheral Present (PPPRB)

Base 0x400F.E000
Offset 0x3A0
Type RO, reset 0x0000.0000

	31	30	29	28	27	26	25	24	23	22	21	20	19	18	17	16
	reserved															
Type	RO	RO	RO	RO	RO	RO	RO	RO	RO	RO	RO	RO	RO	RO	RO	RO
Reset	0	0	0	0	0	0	0	0	0	0	0	0	0	0	0	0
	15	14	13	12	11	10	9	8	7	6	5	4	3	2	1	0
	reserved															P0
Type	RO	RO	RO	RO	RO	RO	RO	RO	RO	RO	RO	RO	RO	RO	RO	RO
Reset	0	0	0	0	0	0	0	0	0	0	0	0	0	0	0	0

Bit/Field	Name	Type	Reset	Description
31:1	reserved	RO	0	Software should not rely on the value of a reserved bit. To provide compatibility with future products, the value of a reserved bit should be preserved across a read-modify-write operation.
0	P0	RO	0x0	PRB Module Present
				Value Description
				0 PRB module is not present.
				1 PRB module is present.

Register 67: Human Interface Master Peripheral Present (PPHIM), offset 0x3A4

The **PPHIM** register provides software information regarding the Human Interface Master (HIM) module.

Important: This register should be used to determine which HIM modules are implemented on this microcontroller.

Human Interface Master Peripheral Present (PPHIM)

Base 0x400F.E000
 Offset 0x3A4
 Type RO, reset 0x0000.0000

	31	30	29	28	27	26	25	24	23	22	21	20	19	18	17	16
	reserved															
Type	RO	RO	RO	RO	RO	RO	RO	RO	RO	RO	RO	RO	RO	RO	RO	RO
Reset	0	0	0	0	0	0	0	0	0	0	0	0	0	0	0	0
	15	14	13	12	11	10	9	8	7	6	5	4	3	2	1	0
	reserved															P0
Type	RO	RO	RO	RO	RO	RO	RO	RO	RO	RO	RO	RO	RO	RO	RO	RO
Reset	0	0	0	0	0	0	0	0	0	0	0	0	0	0	0	0

Bit/Field	Name	Type	Reset	Description
31:1	reserved	RO	0	Software should not rely on the value of a reserved bit. To provide compatibility with future products, the value of a reserved bit should be preserved across a read-modify-write operation.
0	P0	RO	0x0	HIM Module Present
				Value Description
				0 HIM module is not present.
				1 HIM module is present.

Register 68: Watchdog Timer Software Reset (SRWD), offset 0x500

The **SRWD** register provides software the capability to reset the available watchdog modules.

A peripheral is reset by software using a simple two-step process:

1. Software sets a bit (or bits) in the **SRWD** register. While the **SRWD** bit is 1, the peripheral is held in reset.
2. Software completes the reset process by clearing the **SRWD** bit.

There may be latency from the clearing of the **SRWD** bit to when the peripheral is ready for use. Software should check the corresponding **PRWD** bit to verify that the Watchdog Timer Module registers are ready to be accessed.

Important: This register should be used to reset the watchdog modules.

Watchdog Timer Software Reset (SRWD)

Base 0x400F.E000
Offset 0x500
Type RW, reset 0x0000.0000

	31	30	29	28	27	26	25	24	23	22	21	20	19	18	17	16	
	reserved																
Type	RO	RO	RO	RO	RO	RO	RO	RO	RO	RO	RO	RO	RO	RO	RO	RO	
Reset	0	0	0	0	0	0	0	0	0	0	0	0	0	0	0	0	
	15	14	13	12	11	10	9	8	7	6	5	4	3	2	1	0	
	reserved															R1	R0
Type	RO	RO	RO	RO	RO	RO	RO	RO	RO	RO	RO	RO	RO	RO	RW	RW	
Reset	0	0	0	0	0	0	0	0	0	0	0	0	0	0	0	0	

Bit/Field	Name	Type	Reset	Description
31:2	reserved	RO	0	Software should not rely on the value of a reserved bit. To provide compatibility with future products, the value of a reserved bit should be preserved across a read-modify-write operation.
1	R1	RW	0	Watchdog Timer 1 Software Reset
				Value Description
				0 Watchdog module 1 is not reset.
				1 Watchdog module 1 is reset.
0	R0	RW	0	Watchdog Timer 0 Software Reset
				Value Description
				0 Watchdog module 0 is not reset.
				1 Watchdog module 0 is reset.

Register 69: 16/32-Bit General-Purpose Timer Software Reset (SRTIMER), offset 0x504

The **SRTIMER** register provides software the capability to reset the available 16/32-bit timer modules. A peripheral is reset by software using a simple two-step process:

1. Software sets a bit (or bits) in the **SRTIMER** register. While the **SRTIMER** bit is 1, the peripheral is held in reset.
2. Software completes the reset process by clearing the **SRTIMER** bit.

There may be latency from the clearing of the **SRTIMER** bit to when the peripheral is ready for use. Software should check the corresponding **PRTIMER** bit to verify that the Timer Module registers are ready to be accessed.

Important: This register should be used to reset the timer modules.

16/32-Bit General-Purpose Timer Software Reset (SRTIMER)

Base 0x400F.E000
 Offset 0x504
 Type RW, reset 0x0000.0000

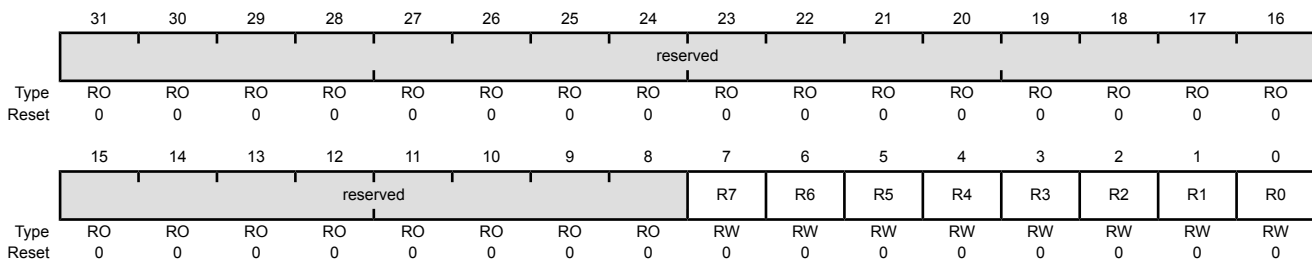

Bit/Field	Name	Type	Reset	Description
31:8	reserved	RO	0	Software should not rely on the value of a reserved bit. To provide compatibility with future products, the value of a reserved bit should be preserved across a read-modify-write operation.
7	R7	RW	0	16/32-Bit General-Purpose Timer 7 Software Reset
				Value Description
				0 16/32-bit general-purpose timer module 7 is not reset.
				1 16/32-bit general-purpose timer module 7 is reset.
6	R6	RW	0	16/32-Bit General-Purpose Timer 6 Software Reset
				Value Description
				0 16/32-bit general-purpose timer module 6 is not reset.
				1 16/32-bit general-purpose timer module 6 is reset.

Bit/Field	Name	Type	Reset	Description
5	R5	RW	0	16/32-Bit General-Purpose Timer 5 Software Reset Value Description 0 16/32-bit general-purpose timer module 5 is not reset. 1 16/32-bit general-purpose timer module 5 is reset.
4	R4	RW	0	16/32-Bit General-Purpose Timer 4 Software Reset Value Description 0 16/32-bit general-purpose timer module 4 is not reset. 1 16/32-bit general-purpose timer module 4 is reset.
3	R3	RW	0	16/32-Bit General-Purpose Timer 3 Software Reset Value Description 0 16/32-bit general-purpose timer module 3 is not reset. 1 16/32-bit general-purpose timer module 3 is reset.
2	R2	RW	0	16/32-Bit General-Purpose Timer 2 Software Reset Value Description 0 16/32-bit general-purpose timer module 2 is not reset. 1 16/32-bit general-purpose timer module 2 is reset.
1	R1	RW	0	16/32-Bit General-Purpose Timer 1 Software Reset Value Description 0 16/32-bit general-purpose timer module 1 is not reset. 1 16/32-bit general-purpose timer module 1 is reset.
0	R0	RW	0	16/32-Bit General-Purpose Timer 0 Software Reset Value Description 0 16/32-bit general-purpose timer module 0 is not reset. 1 16/32-bit general-purpose timer module 0 is reset.

Register 70: General-Purpose Input/Output Software Reset (SRGPIO), offset 0x508

The **SRGPIO** register provides software the capability to reset the available GPIO modules.

A peripheral is reset by software using a simple two-step process:

1. Software sets a bit (or bits) in the **SRGPIO** register. While the **SRGPIO** bit is 1, the peripheral is held in reset.
2. Software completes the reset process by clearing the **SRGPIO** bit.

There may be latency from the clearing of the **SRGPIO** bit to when the peripheral is ready for use. Software should check the corresponding **PRGPIO** bit to verify that the GPIO Module registers are ready to be accessed.

Important: This register should be used to reset the GPIO modules.

General-Purpose Input/Output Software Reset (SRGPIO)

Base 0x400F.E000
 Offset 0x508
 Type RW, reset 0x0000.0000

	31	30	29	28	27	26	25	24	23	22	21	20	19	18	17	16
	reserved															
Type	RO	RO	RO	RO	RO	RO	RO	RO	RO	RO	RO	RO	RO	RO	RO	RO
Reset	0	0	0	0	0	0	0	0	0	0	0	0	0	0	0	0
	15	14	13	12	11	10	9	8	7	6	5	4	3	2	1	0
	reserved	R14	R13	R12	R11	R10	R9	R8	R7	R6	R5	R4	R3	R2	R1	R0
Type	RO	RW	RW	RW	RW	RW	RW	RW	RW	RW	RW	RW	RW	RW	RW	RW
Reset	0	0	0	0	0	0	0	0	0	0	0	0	0	0	0	0

Bit/Field	Name	Type	Reset	Description
31:15	reserved	RO	0	Software should not rely on the value of a reserved bit. To provide compatibility with future products, the value of a reserved bit should be preserved across a read-modify-write operation.
14	R14	RW	0	GPIO Port Q Software Reset Value Description 0 GPIO Port Q is not reset. 1 GPIO Port Q is reset.
13	R13	RW	0	GPIO Port P Software Reset Value Description 0 GPIO Port P is not reset. 1 GPIO Port P is reset.

Bit/Field	Name	Type	Reset	Description
12	R12	RW	0	GPIO Port N Software Reset Value Description 0 GPIO Port N is not reset. 1 GPIO Port N is reset.
11	R11	RW	0	GPIO Port M Software Reset Value Description 0 GPIO Port M is not reset. 1 GPIO Port M is reset.
10	R10	RW	0	GPIO Port L Software Reset Value Description 0 GPIO Port L is not reset. 1 GPIO Port L is reset.
9	R9	RW	0	GPIO Port K Software Reset Value Description 0 GPIO Port K is not reset. 1 GPIO Port K is reset.
8	R8	RW	0	GPIO Port J Software Reset Value Description 0 GPIO Port J is not reset. 1 GPIO Port J is reset.
7	R7	RW	0	GPIO Port H Software Reset Value Description 0 GPIO Port H is not reset. 1 GPIO Port H is reset.
6	R6	RW	0	GPIO Port G Software Reset Value Description 0 GPIO Port G is not reset. 1 GPIO Port G is reset.

Bit/Field	Name	Type	Reset	Description
5	R5	RW	0	GPIO Port F Software Reset Value Description 0 GPIO Port F is not reset. 1 GPIO Port F is reset.
4	R4	RW	0	GPIO Port E Software Reset Value Description 0 GPIO Port E is not reset. 1 GPIO Port E is reset.
3	R3	RW	0	GPIO Port D Software Reset Value Description 0 GPIO Port D is not reset. 1 GPIO Port D is reset.
2	R2	RW	0	GPIO Port C Software Reset Value Description 0 GPIO Port C is not reset. 1 GPIO Port C is reset.
1	R1	RW	0	GPIO Port B Software Reset Value Description 0 GPIO Port B is not reset. 1 GPIO Port B is reset.
0	R0	RW	0	GPIO Port A Software Reset Value Description 0 GPIO Port A is not reset. 1 GPIO Port A is reset.

Register 71: Micro Direct Memory Access Software Reset (SRDMA), offset 0x50C

The **SRDMA** register provides software the capability to reset the available μ DMA module.

A peripheral is reset by software using a simple two-step process:

1. Software sets a bit (or bits) in the **SRDMA** register. While the **SRDMA** bit is 1, the peripheral is held in reset.
2. Software completes the reset process by clearing the **SRDMA** bit.

There may be latency from the clearing of the **SRDMA** bit to when the peripheral is ready for use. Software should check the corresponding **PRDMA** bit to verify that the μ DMA Module registers are ready to be accessed.

Important: This register should be used to reset the μ DMA module.

Micro Direct Memory Access Software Reset (SRDMA)

Base 0x400F.E000
Offset 0x50C
Type RW, reset 0x0000.0000

	31	30	29	28	27	26	25	24	23	22	21	20	19	18	17	16
	reserved															
Type	RO	RO	RO	RO	RO	RO	RO	RO	RO	RO	RO	RO	RO	RO	RO	RO
Reset	0	0	0	0	0	0	0	0	0	0	0	0	0	0	0	0
	15	14	13	12	11	10	9	8	7	6	5	4	3	2	1	0
	reserved															RO
Type	RO	RO	RO	RO	RO	RO	RO	RO	RO	RO	RO	RO	RO	RO	RO	RW
Reset	0	0	0	0	0	0	0	0	0	0	0	0	0	0	0	0

Bit/Field	Name	Type	Reset	Description
31:1	reserved	RO	0	Software should not rely on the value of a reserved bit. To provide compatibility with future products, the value of a reserved bit should be preserved across a read-modify-write operation.
0	R0	RW	0	μ DMA Module Software Reset
	Value	Description		
	0	μ DMA module is not reset.		
	1	μ DMA module is reset.		

Register 72: EPI Software Reset (SREPI), offset 0x510

The **SREPI** register provides software the capability to reset the available EPI module.

A peripheral is reset by software using a simple two-step process:

1. Software sets a bit (or bits) in the **SREPI** register. While the **SREPI** bit is 1, the peripheral is held in reset.
2. Software completes the reset process by clearing the **SREPI** bit.

There may be latency from the clearing of the **SREPI** bit to when the peripheral is ready for use. Software should check the corresponding **PREPI** bit to verify that the EPI Module registers are ready to be accessed.

Important: This register should be used to reset the EPI module.

EPI Software Reset (SREPI)

Base 0x400F.E000
 Offset 0x510
 Type RW, reset 0x0000.0000

	31	30	29	28	27	26	25	24	23	22	21	20	19	18	17	16
	reserved															
Type	RO	RO	RO	RO	RO	RO	RO	RO	RO	RO	RO	RO	RO	RO	RO	RO
Reset	0	0	0	0	0	0	0	0	0	0	0	0	0	0	0	0
	15	14	13	12	11	10	9	8	7	6	5	4	3	2	1	0
	reserved															RO
Type	RO	RO	RO	RO	RO	RO	RO	RO	RO	RO	RO	RO	RO	RO	RO	RW
Reset	0	0	0	0	0	0	0	0	0	0	0	0	0	0	0	0

Bit/Field	Name	Type	Reset	Description
31:1	reserved	RO	0	Software should not rely on the value of a reserved bit. To provide compatibility with future products, the value of a reserved bit should be preserved across a read-modify-write operation.
0	R0	RW	0	EPI Module Software Reset
				Value Description
			0	EPI module is not reset.
			1	EPI module is reset.

Register 73: Hibernation Software Reset (SRHIB), offset 0x514

The **SRHIB** register provides software the capability to reset the available Hibernation module.

A peripheral is reset by software using a simple two-step process:

1. Software sets a bit (or bits) in the **SRHIB** register. While the **SRHIB** bit is 1, the peripheral is held in reset.
2. Software completes the reset process by clearing the **SRHIB** bit.

There may be latency from the clearing of the **SRHIB** bit to when the peripheral is ready for use. Software should check the corresponding **PRHIB** bit to verify that the Hibernation Module registers are ready to be accessed.

Important: This register should be used to reset the Hibernation module.

Hibernation Software Reset (SRHIB)

Base 0x400F.E000

Offset 0x514

Type RW, reset 0x0000.0000

	31	30	29	28	27	26	25	24	23	22	21	20	19	18	17	16
	reserved															
Type	RO	RO	RO	RO	RO	RO	RO	RO	RO	RO	RO	RO	RO	RO	RO	RO
Reset	0	0	0	0	0	0	0	0	0	0	0	0	0	0	0	0
	15	14	13	12	11	10	9	8	7	6	5	4	3	2	1	0
	reserved															RO
Type	RO	RO	RO	RO	RO	RO	RO	RO	RO	RO	RO	RO	RO	RO	RO	RW
Reset	0	0	0	0	0	0	0	0	0	0	0	0	0	0	0	0

Bit/Field	Name	Type	Reset	Description
31:1	reserved	RO	0	Software should not rely on the value of a reserved bit. To provide compatibility with future products, the value of a reserved bit should be preserved across a read-modify-write operation.
0	R0	RW	0	Hibernation Module Software Reset
				Value Description
			0	Hibernation module is not reset.
			1	Hibernation module is reset.

Register 74: Universal Asynchronous Receiver/Transmitter Software Reset (SRUART), offset 0x518

The **SRUART** register provides software the capability to reset the available UART modules.

A peripheral is reset by software using a simple two-step process:

1. Software sets a bit (or bits) in the **SRUART** register. While the **SRUART** bit is 1, the peripheral is held in reset.
2. Software completes the reset process by clearing the **SRUART** bit.

There may be latency from the clearing of the **SRUART** bit to when the peripheral is ready for use. Software should check the corresponding **PRUART** bit to verify that the UART Module registers are ready to be accessed.

Important: This register should be used to reset the UART modules.

Universal Asynchronous Receiver/Transmitter Software Reset (SRUART)

Base 0x400F.E000
 Offset 0x518
 Type RW, reset 0x0000.0000

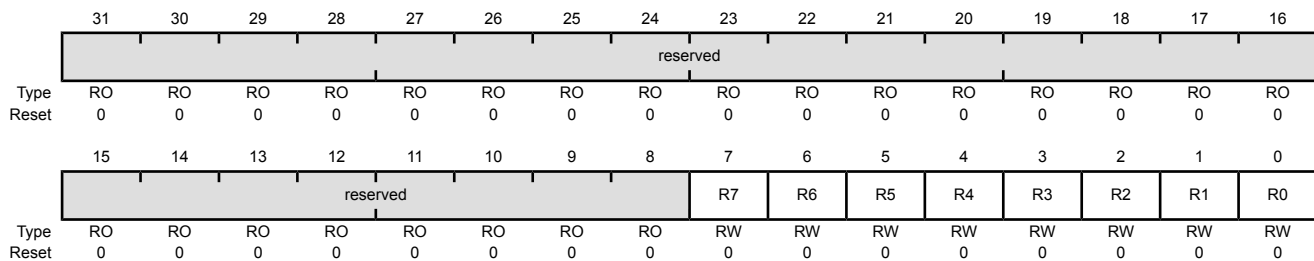

Bit/Field	Name	Type	Reset	Description
31:8	reserved	RO	0	Software should not rely on the value of a reserved bit. To provide compatibility with future products, the value of a reserved bit should be preserved across a read-modify-write operation.
7	R7	RW	0	UART Module 7 Software Reset
				Value Description
				0 UART module 7 is not reset.
				1 UART module 7 is reset.
6	R6	RW	0	UART Module 6 Software Reset
				Value Description
				0 UART module 6 is not reset.
				1 UART module 6 is reset.

Bit/Field	Name	Type	Reset	Description
5	R5	RW	0	UART Module 5 Software Reset Value Description 0 UART module 5 is not reset. 1 UART module 5 is reset.
4	R4	RW	0	UART Module 4 Software Reset Value Description 0 UART module 4 is not reset. 1 UART module 4 is reset.
3	R3	RW	0	UART Module 3 Software Reset Value Description 0 UART module 3 is not reset. 1 UART module 3 is reset.
2	R2	RW	0	UART Module 2 Software Reset Value Description 0 UART module 2 is not reset. 1 UART module 2 is reset.
1	R1	RW	0	UART Module 1 Software Reset Value Description 0 UART module 1 is not reset. 1 UART module 1 is reset.
0	R0	RW	0	UART Module 0 Software Reset Value Description 0 UART module 0 is not reset. 1 UART module 0 is reset.

Register 75: Synchronous Serial Interface Software Reset (SRSSI), offset 0x51C

The **SRSSI** register provides software the capability to reset the available SSI modules.

A peripheral is reset by software using a simple two-step process:

1. Software sets a bit (or bits) in the **SRSSI** register. While the **SRSSI** bit is 1, the peripheral is held in reset.
2. Software completes the reset process by clearing the **SRSSI** bit.

There may be latency from the clearing of the **SRSSI** bit to when the peripheral is ready for use. Software should check the corresponding **PRSSI** bit to verify that the SSI Module registers are ready to be accessed.

Important: This register should be used to reset the SSI modules.

Synchronous Serial Interface Software Reset (SRSSI)

Base 0x400F.E000
 Offset 0x51C
 Type RW, reset 0x0000.0000

	31	30	29	28	27	26	25	24	23	22	21	20	19	18	17	16
	reserved															
Type	RO	RO	RO	RO	RO	RO	RO	RO	RO	RO	RO	RO	RO	RO	RO	RO
Reset	0	0	0	0	0	0	0	0	0	0	0	0	0	0	0	0
	15	14	13	12	11	10	9	8	7	6	5	4	3	2	1	0
	reserved												R3	R2	R1	R0
Type	RO	RO	RO	RO	RO	RO	RO	RO	RO	RO	RO	RO	RW	RW	RW	RW
Reset	0	0	0	0	0	0	0	0	0	0	0	0	0	0	0	0

Bit/Field	Name	Type	Reset	Description
31:4	reserved	RO	0	Software should not rely on the value of a reserved bit. To provide compatibility with future products, the value of a reserved bit should be preserved across a read-modify-write operation.
3	R3	RW	0	SSI Module 3 Software Reset
				Value Description
				0 SSI module 3 is not reset.
				1 SSI module 3 is reset.
2	R2	RW	0	SSI Module 2 Software Reset
				Value Description
				0 SSI module 2 is not reset.
				1 SSI module 2 is reset.

Bit/Field	Name	Type	Reset	Description
1	R1	RW	0	SSI Module 1 Software Reset Value Description 0 SSI module 1 is not reset. 1 SSI module 1 is reset.
0	R0	RW	0	SSI Module 0 Software Reset Value Description 0 SSI module 0 is not reset. 1 SSI module 0 is reset.

Register 76: Inter-Integrated Circuit Software Reset (SRI2C), offset 0x520

The **SRI2C** register provides software the capability to reset the available I²C modules.

A peripheral is reset by software using a simple two-step process:

1. Software sets a bit (or bits) in the **SRI2C** register. While the **SRI2C** bit is 1, the peripheral is held in reset.
2. Software completes the reset process by clearing the **SRI2C** bit.

There may be latency from the clearing of the **SRI2C** bit to when the peripheral is ready for use. Software should check the corresponding **PRi2C** bit to verify that the I²C Module registers are ready to be accessed.

Important: This register should be used to reset the I²C modules.

Inter-Integrated Circuit Software Reset (SRI2C)

Base 0x400F.E000
 Offset 0x520
 Type RW, reset 0x0000.0000

	31	30	29	28	27	26	25	24	23	22	21	20	19	18	17	16
	reserved															
Type	RO	RO	RO	RO	RO	RO	RO	RO	RO	RO	RO	RO	RO	RO	RO	RO
Reset	0	0	0	0	0	0	0	0	0	0	0	0	0	0	0	0
	15	14	13	12	11	10	9	8	7	6	5	4	3	2	1	0
	reserved						R9	R8	R7	R6	R5	R4	R3	R2	R1	R0
Type	RO	RO	RO	RO	RO	RO	RW	RW	RW	RW	RW	RW	RW	RW	RW	RW
Reset	0	0	0	0	0	0	0	0	0	0	0	0	0	0	0	0

Bit/Field	Name	Type	Reset	Description
31:10	reserved	RO	0	Software should not rely on the value of a reserved bit. To provide compatibility with future products, the value of a reserved bit should be preserved across a read-modify-write operation.
9	R9	RW	0	I ² C Module 9 Software Reset Value Description 0 I ² C module 9 is not reset. 1 I ² C module 9 is reset.
8	R8	RW	0	I ² C Module 8 Software Reset Value Description 0 I ² C module 8 is not reset. 1 I ² C module 8 is reset.
7	R7	RW	0	I ² C Module 7 Software Reset Value Description 0 I ² C module 7 is not reset. 1 I ² C module 7 is reset.

Bit/Field	Name	Type	Reset	Description
6	R6	RW	0	I ² C Module 6 Software Reset Value Description 0 I ² C module 6 is not reset. 1 I ² C module 6 is reset.
5	R5	RW	0	I ² C Module 5 Software Reset Value Description 0 I ² C module 5 is not reset. 1 I ² C module 5 is reset.
4	R4	RW	0	I ² C Module 4 Software Reset Value Description 0 I ² C module 4 is not reset. 1 I ² C module 4 is reset.
3	R3	RW	0	I ² C Module 3 Software Reset Value Description 0 I ² C module 3 is not reset. 1 I ² C module 3 is reset.
2	R2	RW	0	I ² C Module 2 Software Reset Value Description 0 I ² C module 2 is not reset. 1 I ² C module 2 is reset.
1	R1	RW	0	I ² C Module 1 Software Reset Value Description 0 I ² C module 1 is not reset. 1 I ² C module 1 is reset.
0	R0	RW	0	I ² C Module 0 Software Reset Value Description 0 I ² C module 0 is not reset. 1 I ² C module 0 is reset.

Register 77: Universal Serial Bus Software Reset (SRUSB), offset 0x528

The **SRUSB** register provides software the capability to reset the available USB module.

A peripheral is reset by software using a simple two-step process:

1. Software sets a bit (or bits) in the **SRUSB** register. While the **SRUSB** bit is 1, the peripheral is held in reset.
2. Software completes the reset process by clearing the **SRUSB** bit.

There may be latency from the clearing of the **SRUSB** bit to when the peripheral is ready for use. Software should check the corresponding **PRUSB** bit to verify that the USB Module registers are ready to be accessed.

Important: This register should be used to reset the USB module.

Universal Serial Bus Software Reset (SRUSB)

Base 0x400F.E000
 Offset 0x528
 Type RW, reset 0x0000.0000

	31	30	29	28	27	26	25	24	23	22	21	20	19	18	17	16
	reserved															
Type	RO	RO	RO	RO	RO	RO	RO	RO	RO	RO	RO	RO	RO	RO	RO	RO
Reset	0	0	0	0	0	0	0	0	0	0	0	0	0	0	0	0
	15	14	13	12	11	10	9	8	7	6	5	4	3	2	1	0
	reserved															RO
Type	RO	RO	RO	RO	RO	RO	RO	RO	RO	RO	RO	RO	RO	RO	RO	RW
Reset	0	0	0	0	0	0	0	0	0	0	0	0	0	0	0	0

Bit/Field	Name	Type	Reset	Description
31:1	reserved	RO	0	Software should not rely on the value of a reserved bit. To provide compatibility with future products, the value of a reserved bit should be preserved across a read-modify-write operation.
0	R0	RW	0	USB Module Software Reset
				Value Description
				0 USB module is not reset.
				1 USB module is reset.

Register 78: Ethernet PHY Software Reset (SREPHY), offset 0x530

The **SREPHY** register provides software the capability to reset the available PHY module.

A peripheral is reset by software using a simple two-step process:

1. Software sets a bit (or bits) in the **SREPHY** register. While the **SREPHY** bit is 1, the peripheral is held in reset.
2. Software completes the reset process by clearing the **SREPHY** bit.

There may be latency from the clearing of the **SREPHY** bit to when the peripheral is ready for use. Software should check the corresponding **PREPHY** bit to verify that the EPHY Module registers are ready to be accessed.

Important: This register should be used to reset the Ethernet PHY module.

Ethernet PHY Software Reset (SREPHY)

Base 0x400F.E000

Offset 0x530

Type RW, reset 0x0000.0000

	31	30	29	28	27	26	25	24	23	22	21	20	19	18	17	16
	reserved															
Type	RO	RO	RO	RO	RO	RO	RO	RO	RO	RO	RO	RO	RO	RO	RO	RO
Reset	0	0	0	0	0	0	0	0	0	0	0	0	0	0	0	0
	15	14	13	12	11	10	9	8	7	6	5	4	3	2	1	0
	reserved															RO
Type	RO	RO	RO	RO	RO	RO	RO	RO	RO	RO	RO	RO	RO	RO	RO	RW
Reset	0	0	0	0	0	0	0	0	0	0	0	0	0	0	0	0

Bit/Field	Name	Type	Reset	Description
31:1	reserved	RO	0	Software should not rely on the value of a reserved bit. To provide compatibility with future products, the value of a reserved bit should be preserved across a read-modify-write operation.
0	R0	RW	0	Ethernet PHY Module Software Reset
				Value Description
			0	Ethernet PHY module is not reset.
			1	Ethernet PHY module is reset.

Register 79: Controller Area Network Software Reset (SRCAN), offset 0x534

The **SRCAN** register provides software the capability to reset the available CAN modules.

A peripheral is reset by software using a simple two-step process:

1. Software sets a bit (or bits) in the **SRCAN** register. While the **SRCAN** bit is 1, the peripheral is held in reset.
2. Software completes the reset process by clearing the **SRCAN** bit.

There may be latency from the clearing of the **SRCAN** bit to when the peripheral is ready for use. Software should check the corresponding **PRCAN** bit to verify that the CAN Module registers are ready to be accessed.

Important: This register should be used to reset the CAN modules.

Controller Area Network Software Reset (SRCAN)

Base 0x400F.E000
 Offset 0x534
 Type RW, reset 0x0000.0000

	31	30	29	28	27	26	25	24	23	22	21	20	19	18	17	16	
	reserved																
Type	RO	RO	RO	RO	RO	RO	RO	RO	RO	RO	RO	RO	RO	RO	RO	RO	
Reset	0	0	0	0	0	0	0	0	0	0	0	0	0	0	0	0	
	15	14	13	12	11	10	9	8	7	6	5	4	3	2	1	0	
	reserved															R1	R0
Type	RO	RO	RO	RO	RO	RO	RO	RO	RO	RO	RO	RO	RO	RO	RW	RW	
Reset	0	0	0	0	0	0	0	0	0	0	0	0	0	0	0	0	

Bit/Field	Name	Type	Reset	Description
31:2	reserved	RO	0	Software should not rely on the value of a reserved bit. To provide compatibility with future products, the value of a reserved bit should be preserved across a read-modify-write operation.
1	R1	RW	0	CAN Module 1 Software Reset Value Description 0 CAN module 1 is not reset. 1 CAN module 1 is reset.
0	R0	RW	0	CAN Module 0 Software Reset Value Description 0 CAN module 0 is not reset. 1 CAN module 0 is reset.

Register 80: Analog-to-Digital Converter Software Reset (SRADC), offset 0x538

The **SRADC** register provides software the capability to reset the available ADC modules.

A peripheral is reset by software using a simple two-step process:

1. Software sets a bit (or bits) in the **SRADC** register. While the **SRADC** bit is 1, the peripheral is held in reset.
2. Software completes the reset process by clearing the **SRADC** bit.

There may be latency from the clearing of the **SRADC** bit to when the peripheral is ready for use. Software should check the corresponding **PRADC** bit to verify that the ADC Module registers are ready to be accessed.

Important: This register should be used to reset the ADC modules.

Analog-to-Digital Converter Software Reset (SRADC)

Base 0x400F.E000
Offset 0x538
Type RW, reset 0x0000.0000

	31	30	29	28	27	26	25	24	23	22	21	20	19	18	17	16	
	reserved																
Type	RO	RO	RO	RO	RO	RO	RO	RO	RO	RO	RO	RO	RO	RO	RO	RO	
Reset	0	0	0	0	0	0	0	0	0	0	0	0	0	0	0	0	
	15	14	13	12	11	10	9	8	7	6	5	4	3	2	1	0	
	reserved															R1	R0
Type	RO	RO	RO	RO	RO	RO	RO	RO	RO	RO	RO	RO	RO	RO	RW	RW	
Reset	0	0	0	0	0	0	0	0	0	0	0	0	0	0	0	0	

Bit/Field	Name	Type	Reset	Description
31:2	reserved	RO	0	Software should not rely on the value of a reserved bit. To provide compatibility with future products, the value of a reserved bit should be preserved across a read-modify-write operation.
1	R1	RW	0	ADC Module 1 Software Reset
				Value Description
				0 ADC module 1 is not reset.
				1 ADC module 1 is reset.
0	R0	RW	0	ADC Module 0 Software Reset
				Value Description
				0 ADC module 0 is not reset.
				1 ADC module 0 is reset.

Register 81: Analog Comparator Software Reset (SRACMP), offset 0x53C

The **SRACMP** register provides software the capability to reset the available analog comparator module.

A block is reset by software using a simple two-step process:

1. Software sets a bit (or bits) in the **SRACMP** register. While the **SRACMP** bit is 1, the module is held in reset.
2. Software completes the reset process by clearing the **SRACMP** bit.

There may be latency from the clearing of the **SRACMP** bit to when the module is ready for use. Software should check the corresponding **PRACMP** bit to verify that the Analog Comparator Module registers are ready to be accessed.

Important: This register should be used to reset the analog comparator module.

Analog Comparator Software Reset (SRACMP)

Base 0x400F.E000
 Offset 0x53C
 Type RW, reset 0x0000.0000

	31	30	29	28	27	26	25	24	23	22	21	20	19	18	17	16
	reserved															
Type	RO	RO	RO	RO	RO	RO	RO	RO	RO	RO	RO	RO	RO	RO	RO	RO
Reset	0	0	0	0	0	0	0	0	0	0	0	0	0	0	0	0
	15	14	13	12	11	10	9	8	7	6	5	4	3	2	1	0
	reserved															RO
Type	RO	RO	RO	RO	RO	RO	RO	RO	RO	RO	RO	RO	RO	RO	RO	RW
Reset	0	0	0	0	0	0	0	0	0	0	0	0	0	0	0	0

Bit/Field	Name	Type	Reset	Description
31:1	reserved	RO	0	Software should not rely on the value of a reserved bit. To provide compatibility with future products, the value of a reserved bit should be preserved across a read-modify-write operation.
0	R0	RW	0	Analog Comparator Module 0 Software Reset
				Value Description
			0	Analog comparator module is not reset.
			1	Analog comparator module is reset.

Register 82: Pulse Width Modulator Software Reset (SRPWM), offset 0x540

The **SRPWM** register provides software the capability to reset the available PWM modules.

A peripheral is reset by software using a simple two-step process:

1. Software sets a bit (or bits) in the **SRPWM** register. While the **SRPWM** bit is 1, the peripheral is held in reset.
2. Software completes the reset process by clearing the **SRPWM** bit.

There may be latency from the clearing of the **SRPWM** bit to when the peripheral is ready for use. Software should check the corresponding **PRPWM** bit to verify that the PWM Module registers are ready to be accessed.

Important: This register should be used to reset the PWM modules.

Pulse Width Modulator Software Reset (SRPWM)

Base 0x400F.E000

Offset 0x540

Type RW, reset 0x0000.0000

	31	30	29	28	27	26	25	24	23	22	21	20	19	18	17	16
	reserved															
Type	RO	RO	RO	RO	RO	RO	RO	RO	RO	RO	RO	RO	RO	RO	RO	RO
Reset	0	0	0	0	0	0	0	0	0	0	0	0	0	0	0	0
	15	14	13	12	11	10	9	8	7	6	5	4	3	2	1	0
	reserved															RO
Type	RO	RO	RO	RO	RO	RO	RO	RO	RO	RO	RO	RO	RO	RO	RO	RW
Reset	0	0	0	0	0	0	0	0	0	0	0	0	0	0	0	0

Bit/Field	Name	Type	Reset	Description
31:1	reserved	RO	0	Software should not rely on the value of a reserved bit. To provide compatibility with future products, the value of a reserved bit should be preserved across a read-modify-write operation.
0	R0	RW	0	PWM Module 0 Software Reset
				Value Description
				0 PWM module 0 is not reset.
				1 PWM module 0 is reset.

Register 83: Quadrature Encoder Interface Software Reset (SRQEI), offset 0x544

The **SRQEI** register provides software the capability to reset the available QEI modules.

A peripheral is reset by software using a simple two-step process:

1. Software sets a bit (or bits) in the **SRQEI** register. While the **SRQEI** bit is 1, the peripheral is held in reset.
2. Software completes the reset process by clearing the **SRQEI** bit.

There may be latency from the clearing of the **SRQEI** bit to when the peripheral is ready for use. Software should check the corresponding **PRQEI** bit to verify that the QEI Module registers are ready to be accessed.

Important: This register should be used to reset the QEI modules.

Quadrature Encoder Interface Software Reset (SRQEI)

Base 0x400F.E000
 Offset 0x544
 Type RW, reset 0x0000.0000

	31	30	29	28	27	26	25	24	23	22	21	20	19	18	17	16
	reserved															
Type	RO	RO	RO	RO	RO	RO	RO	RO	RO	RO	RO	RO	RO	RO	RO	RO
Reset	0	0	0	0	0	0	0	0	0	0	0	0	0	0	0	0
	15	14	13	12	11	10	9	8	7	6	5	4	3	2	1	0
	reserved															RO
Type	RO	RO	RO	RO	RO	RO	RO	RO	RO	RO	RO	RO	RO	RO	RO	RW
Reset	0	0	0	0	0	0	0	0	0	0	0	0	0	0	0	0

Bit/Field	Name	Type	Reset	Description
31:1	reserved	RO	0	Software should not rely on the value of a reserved bit. To provide compatibility with future products, the value of a reserved bit should be preserved across a read-modify-write operation.
0	R0	RW	0	QEI Module 0 Software Reset
				Value Description
				0 QEI module 0 is not reset.
				1 QEI module 0 is reset.

Register 84: EEPROM Software Reset (SREEPROM), offset 0x558

The **SREEPROM** register provides software the capability to reset the available EEPROM module.

A peripheral is reset by software using a simple two-step process:

1. Software sets a bit (or bits) in the **SREEPROM** register. While the **SREEPROM** bit is 1, the peripheral is held in reset.
2. Software completes the reset process by clearing the **SREEPROM** bit.

There may be latency from the clearing of the **SREEPROM** bit to when the peripheral is ready for use. Software should check the corresponding **PREEPROM** bit to verify that the EEPROM Module registers are ready to be accessed.

EEPROM Software Reset (SREEPROM)

Base 0x400F.E000
Offset 0x558
Type RW, reset 0x0000.0000

	31	30	29	28	27	26	25	24	23	22	21	20	19	18	17	16
	reserved															
Type	RO	RO	RO	RO	RO	RO	RO	RO	RO	RO	RO	RO	RO	RO	RO	RO
Reset	0	0	0	0	0	0	0	0	0	0	0	0	0	0	0	0
	15	14	13	12	11	10	9	8	7	6	5	4	3	2	1	0
	reserved															R0
Type	RO	RO	RO	RO	RO	RO	RO	RO	RO	RO	RO	RO	RO	RO	RO	RW
Reset	0	0	0	0	0	0	0	0	0	0	0	0	0	0	0	0

Bit/Field	Name	Type	Reset	Description
31:1	reserved	RO	0	Software should not rely on the value of a reserved bit. To provide compatibility with future products, the value of a reserved bit should be preserved across a read-modify-write operation.
0	R0	RW	0	EEPROM Module 0 Software Reset
				Value Description
				0 EEPROM module is not reset.
				1 EEPROM module is reset.

Register 85: CRC and Cryptographic Modules Software Reset (SRCCM), offset 0x574

The **SRCCM** register provides software the capability to reset the CRC and Cryptographic Modules (AES, DES, and SHA/MD5).

A module is reset by software using a simple two-step process:

1. Software sets the bit in the **SRCCM** register. While the **SRCCM** bit is 1, the peripherals are held in reset.
2. Software completes the reset process by clearing the **SRCCM** bit.

There may be latency from the clearing of the **SRCCM** bit to when the peripheral is ready for use. Software should check the corresponding **PRCCM** bit to verify that the CRC and Cryptographic Module (AES, DES, and SHA/MD5) registers are ready to be accessed.

Important: This register should be used to reset the CRC, AES, DES, and SHA/MD5 modules.

CRC and Cryptographic Modules Software Reset (SRCCM)

Base 0x400F.E000
 Offset 0x574
 Type RW, reset 0x0000.0000

	31	30	29	28	27	26	25	24	23	22	21	20	19	18	17	16
	reserved															
Type	RO	RO	RO	RO	RO	RO	RO	RO	RO	RO	RO	RO	RO	RO	RO	RO
Reset	0	0	0	0	0	0	0	0	0	0	0	0	0	0	0	0
	15	14	13	12	11	10	9	8	7	6	5	4	3	2	1	0
	reserved															RO
Type	RO	RO	RO	RO	RO	RO	RO	RO	RO	RO	RO	RO	RO	RO	RO	RW
Reset	0	0	0	0	0	0	0	0	0	0	0	0	0	0	0	0

Bit/Field	Name	Type	Reset	Description
31:1	reserved	RO	0	Software should not rely on the value of a reserved bit. To provide compatibility with future products, the value of a reserved bit should be preserved across a read-modify-write operation.
0	R0	RW	0	CRC and Cryptographic Modules Software Reset
				Value Description
				0 The CRC, AES, DES, and SHA/MD5 modules are not reset.
				1 The CRC, AES, DES, and SHA/MD5 modules are reset.

Register 86: Ethernet MAC Software Reset (SREMAC), offset 0x59C

The **SREMAC** register provides software the capability to reset the available Ethernet MAC module.

A peripheral is reset by software using a simple two-step process:

1. Software sets a bit (or bits) in the **SREMAC** register. While the **SREMAC** bit is 1, the peripheral is held in reset.
2. Software completes the reset process by clearing the **SREMAC** bit.

There may be latency from the clearing of the **SREMAC** bit to when the peripheral is ready for use. Software should check the corresponding **PREMAC** bit to verify that the Ethernet MAC Module registers are ready to be accessed.

Important: This register should be used to reset the Ethernet controller MAC module.

Ethernet MAC Software Reset (SREMAC)

Base 0x400F.E000
Offset 0x59C
Type RW, reset 0x0000.0000

	31	30	29	28	27	26	25	24	23	22	21	20	19	18	17	16
	reserved															
Type	RO	RO	RO	RO	RO	RO	RO	RO	RO	RO	RO	RO	RO	RO	RO	RO
Reset	0	0	0	0	0	0	0	0	0	0	0	0	0	0	0	0
	15	14	13	12	11	10	9	8	7	6	5	4	3	2	1	0
	reserved															RO
Type	RO	RO	RO	RO	RO	RO	RO	RO	RO	RO	RO	RO	RO	RO	RO	RW
Reset	0	0	0	0	0	0	0	0	0	0	0	0	0	0	0	0

Bit/Field	Name	Type	Reset	Description
31:1	reserved	RO	0	Software should not rely on the value of a reserved bit. To provide compatibility with future products, the value of a reserved bit should be preserved across a read-modify-write operation.
0	R0	RW	0	Ethernet Controller MAC Module 0 Software Reset
				Value Description
			0	Ethernet Controller MAC module 0 is not reset.
			1	Ethernet Controller MAC module 0 is reset.

Register 87: Watchdog Timer Run Mode Clock Gating Control (RCGCWD), offset 0x600

The **RCGCWD** register provides software the capability to enable and disable watchdog modules in Run mode. When enabled, a module is provided a clock and accesses to module registers are allowed. When disabled, the clock is disabled to save power and accesses to module registers generate a bus fault.

Important: This register should be used to control the clocking for the watchdog modules

Watchdog Timer Run Mode Clock Gating Control (RCGCWD)

Base 0x400F.E000
 Offset 0x600
 Type RW, reset 0x0000.0000

	31	30	29	28	27	26	25	24	23	22	21	20	19	18	17	16	
	reserved																
Type	RO	RO	RO	RO	RO	RO	RO	RO	RO	RO	RO	RO	RO	RO	RO	RO	
Reset	0	0	0	0	0	0	0	0	0	0	0	0	0	0	0	0	
	15	14	13	12	11	10	9	8	7	6	5	4	3	2	1	0	
	reserved															R1	R0
Type	RO	RO	RO	RO	RO	RO	RO	RO	RO	RO	RO	RO	RO	RO	RW	RW	
Reset	0	0	0	0	0	0	0	0	0	0	0	0	0	0	0	0	

Bit/Field	Name	Type	Reset	Description
31:2	reserved	RO	0	Software should not rely on the value of a reserved bit. To provide compatibility with future products, the value of a reserved bit should be preserved across a read-modify-write operation.
1	R1	RW	0	Watchdog Timer 1 Run Mode Clock Gating Control Value Description 0 Watchdog module 1 is disabled. 1 Enable and provide a clock to Watchdog module 1 in Run mode.
0	R0	RW	0	Watchdog Timer 0 Run Mode Clock Gating Control Value Description 0 Watchdog module 0 is disabled. 1 Enable and provide a clock to Watchdog module 0 in Run mode.

Register 88: 16/32-Bit General-Purpose Timer Run Mode Clock Gating Control (RCGCTIMER), offset 0x604

The **RCGCGPT32** register provides software the capability to enable and disable 16/32-bit timer modules in Run mode. When enabled, a module is provided a clock and accesses to module registers are allowed. When disabled, the clock is disabled to save power and accesses to module registers generate a bus fault.

Important: This register should be used to control the clocking for the timer modules.

16/32-Bit General-Purpose Timer Run Mode Clock Gating Control (RCGCTIMER)

Base 0x400F.E000

Offset 0x604

Type RW, reset 0x0000.0000

	31	30	29	28	27	26	25	24	23	22	21	20	19	18	17	16
	reserved															
Type	RO	RO	RO	RO	RO	RO	RO	RO	RO	RO	RO	RO	RO	RO	RO	RO
Reset	0	0	0	0	0	0	0	0	0	0	0	0	0	0	0	0
	15	14	13	12	11	10	9	8	7	6	5	4	3	2	1	0
	reserved								R7	R6	R5	R4	R3	R2	R1	R0
Type	RO	RO	RO	RO	RO	RO	RO	RO	RW	RW	RW	RW	RW	RW	RW	RW
Reset	0	0	0	0	0	0	0	0	0	0	0	0	0	0	0	0

Bit/Field	Name	Type	Reset	Description
31:8	reserved	RO	0	Software should not rely on the value of a reserved bit. To provide compatibility with future products, the value of a reserved bit should be preserved across a read-modify-write operation.
7	R7	RW	0	16/32-Bit General-Purpose Timer 7 Run Mode Clock Gating Control Value Description 0 16/32-bit general-purpose timer module 7 is disabled. 1 Enable and provide a clock to 16/32-bit general-purpose timer module 7 in Run mode.
6	R6	RW	0	16/32-Bit General-Purpose Timer 6 Run Mode Clock Gating Control Value Description 0 16/32-bit general-purpose timer module 6 is disabled. 1 Enable and provide a clock to 16/32-bit general-purpose timer module 6 in Run mode.
5	R5	RW	0	16/32-Bit General-Purpose Timer 5 Run Mode Clock Gating Control Value Description 0 16/32-bit general-purpose timer module 5 is disabled. 1 Enable and provide a clock to 16/32-bit general-purpose timer module 5 in Run mode.

Bit/Field	Name	Type	Reset	Description
4	R4	RW	0	16/32-Bit General-Purpose Timer 4 Run Mode Clock Gating Control Value Description 0 16/32-bit general-purpose timer module 4 is disabled. 1 Enable and provide a clock to 16/32-bit general-purpose timer module 4 in Run mode.
3	R3	RW	0	16/32-Bit General-Purpose Timer 3 Run Mode Clock Gating Control Value Description 0 16/32-bit general-purpose timer module 3 is disabled. 1 Enable and provide a clock to 16/32-bit general-purpose timer module 3 in Run mode.
2	R2	RW	0	16/32-Bit General-Purpose Timer 2 Run Mode Clock Gating Control Value Description 0 16/32-bit general-purpose timer module 2 is disabled. 1 Enable and provide a clock to 16/32-bit general-purpose timer module 2 in Run mode.
1	R1	RW	0	16/32-Bit General-Purpose Timer 1 Run Mode Clock Gating Control Value Description 0 16/32-bit general-purpose timer module 1 is disabled. 1 Enable and provide a clock to 16/32-bit general-purpose timer module 1 in Run mode.
0	R0	RW	0	16/32-Bit General-Purpose Timer 0 Run Mode Clock Gating Control Value Description 0 16/32-bit general-purpose timer module 0 is disabled. 1 Enable and provide a clock to 16/32-bit general-purpose timer module 0 in Run mode.

Register 89: General-Purpose Input/Output Run Mode Clock Gating Control (RCGCGPIO), offset 0x608

The **RCGCGPIO** register provides software the capability to enable and disable GPIO modules in Run mode. When enabled, a module is provided a clock and accesses to module registers are allowed. When disabled, the clock is disabled to save power and accesses to module registers generate a bus fault.

Important: This register should be used to control the clocking for the GPIO modules.

General-Purpose Input/Output Run Mode Clock Gating Control (RCGCGPIO)

Base 0x400F.E000

Offset 0x608

Type RW, reset 0x0000.0000

	31	30	29	28	27	26	25	24	23	22	21	20	19	18	17	16
	reserved															
Type	RO	RO	RO	RO	RO	RO	RO	RO	RO	RO	RO	RO	RO	RO	RO	RO
Reset	0	0	0	0	0	0	0	0	0	0	0	0	0	0	0	0
	15	14	13	12	11	10	9	8	7	6	5	4	3	2	1	0
	reserved	R14	R13	R12	R11	R10	R9	R8	R7	R6	R5	R4	R3	R2	R1	R0
Type	RO	RW	RW	RW	RW	RW	RW	RW	RW	RW	RW	RW	RW	RW	RW	RW
Reset	0	0	0	0	0	0	0	0	0	0	0	0	0	0	0	0

Bit/Field	Name	Type	Reset	Description
31:15	reserved	RO	0	Software should not rely on the value of a reserved bit. To provide compatibility with future products, the value of a reserved bit should be preserved across a read-modify-write operation.
14	R14	RW	0	GPIO Port Q Run Mode Clock Gating Control Value Description 0 GPIO Port Q is disabled. 1 Enable and provide a clock to GPIO Port Q in Run mode.
13	R13	RW	0	GPIO Port P Run Mode Clock Gating Control Value Description 0 GPIO Port P is disabled. 1 Enable and provide a clock to GPIO Port P in Run mode.
12	R12	RW	0	GPIO Port N Run Mode Clock Gating Control Value Description 0 GPIO Port N is disabled. 1 Enable and provide a clock to GPIO Port N in Run mode.
11	R11	RW	0	GPIO Port M Run Mode Clock Gating Control Value Description 0 GPIO Port M is disabled. 1 Enable and provide a clock to GPIO Port M in Run mode.

Bit/Field	Name	Type	Reset	Description
10	R10	RW	0	GPIO Port L Run Mode Clock Gating Control Value Description 0 GPIO Port L is disabled. 1 Enable and provide a clock to GPIO Port L in Run mode.
9	R9	RW	0	GPIO Port K Run Mode Clock Gating Control Value Description 0 GPIO Port K is disabled. 1 Enable and provide a clock to GPIO Port K in Run mode.
8	R8	RW	0	GPIO Port J Run Mode Clock Gating Control Value Description 0 GPIO Port J is disabled. 1 Enable and provide a clock to GPIO Port J in Run mode.
7	R7	RW	0	GPIO Port H Run Mode Clock Gating Control Value Description 0 GPIO Port H is disabled. 1 Enable and provide a clock to GPIO Port H in Run mode.
6	R6	RW	0	GPIO Port G Run Mode Clock Gating Control Value Description 0 GPIO Port G is disabled. 1 Enable and provide a clock to GPIO Port G in Run mode.
5	R5	RW	0	GPIO Port F Run Mode Clock Gating Control Value Description 0 GPIO Port F is disabled. 1 Enable and provide a clock to GPIO Port F in Run mode.
4	R4	RW	0	GPIO Port E Run Mode Clock Gating Control Value Description 0 GPIO Port E is disabled. 1 Enable and provide a clock to GPIO Port E in Run mode.

Bit/Field	Name	Type	Reset	Description
3	R3	RW	0	GPIO Port D Run Mode Clock Gating Control Value Description 0 GPIO Port D is disabled. 1 Enable and provide a clock to GPIO Port D in Run mode.
2	R2	RW	0	GPIO Port C Run Mode Clock Gating Control Value Description 0 GPIO Port C is disabled. 1 Enable and provide a clock to GPIO Port C in Run mode.
1	R1	RW	0	GPIO Port B Run Mode Clock Gating Control Value Description 0 GPIO Port B is disabled. 1 Enable and provide a clock to GPIO Port B in Run mode.
0	R0	RW	0	GPIO Port A Run Mode Clock Gating Control Value Description 0 GPIO Port A is disabled. 1 Enable and provide a clock to GPIO Port A in Run mode.

Register 90: Micro Direct Memory Access Run Mode Clock Gating Control (RCGCDMA), offset 0x60C

The **RCGCDMA** register provides software the capability to enable and disable the μ DMA module in Run mode. When enabled, the module is provided a clock and accesses to module registers are allowed. When disabled, the clock is disabled to save power and accesses to module registers generate a bus fault.

Important: This register should be used to control the clocking for the μ DMA module.

Micro Direct Memory Access Run Mode Clock Gating Control (RCGCDMA)

Base 0x400F.E000
 Offset 0x60C
 Type RW, reset 0x0000.0000

	31	30	29	28	27	26	25	24	23	22	21	20	19	18	17	16
	reserved															
Type	RO	RO	RO	RO	RO	RO	RO	RO	RO	RO	RO	RO	RO	RO	RO	RO
Reset	0	0	0	0	0	0	0	0	0	0	0	0	0	0	0	0
	15	14	13	12	11	10	9	8	7	6	5	4	3	2	1	0
	reserved															RO
Type	RO	RO	RO	RO	RO	RO	RO	RO	RO	RO	RO	RO	RO	RO	RO	RW
Reset	0	0	0	0	0	0	0	0	0	0	0	0	0	0	0	0

Bit/Field	Name	Type	Reset	Description
31:1	reserved	RO	0	Software should not rely on the value of a reserved bit. To provide compatibility with future products, the value of a reserved bit should be preserved across a read-modify-write operation.
0	R0	RW	0	μ DMA Module Run Mode Clock Gating Control
				Value Description
				0 μ DMA module is disabled.
				1 Enable and provide a clock to the μ DMA module in Run mode.

Register 91: EPI Run Mode Clock Gating Control (RCGCEPI), offset 0x610

The **RCGCEPI** register provides software the capability to enable and disable the EPI module in Run mode. When enabled, the module is provided a clock and accesses to module registers are allowed. When disabled, the clock is disabled to save power and accesses to module registers generate a bus fault.

Important: This register should be used to control the clocking for the EPI module.

EPI Run Mode Clock Gating Control (RCGCEPI)

Base 0x400F.E000

Offset 0x610

Type RW, reset 0x0000.0000

	31	30	29	28	27	26	25	24	23	22	21	20	19	18	17	16
	reserved															
Type	RO	RO	RO	RO	RO	RO	RO	RO	RO	RO	RO	RO	RO	RO	RO	RO
Reset	0	0	0	0	0	0	0	0	0	0	0	0	0	0	0	0
	15	14	13	12	11	10	9	8	7	6	5	4	3	2	1	0
	reserved															RO
Type	RO	RO	RO	RO	RO	RO	RO	RO	RO	RO	RO	RO	RO	RO	RO	RW
Reset	0	0	0	0	0	0	0	0	0	0	0	0	0	0	0	0

Bit/Field	Name	Type	Reset	Description
31:1	reserved	RO	0	Software should not rely on the value of a reserved bit. To provide compatibility with future products, the value of a reserved bit should be preserved across a read-modify-write operation.
0	R0	RW	0	EPI Module Run Mode Clock Gating Control
				Value Description
			0	EPI module is disabled.
			1	Enable and provide a clock to the EPI module in Run mode.

Register 92: Hibernation Run Mode Clock Gating Control (RCGCHIB), offset 0x614

The **RCGCHIB** register provides software the capability to enable and disable the Hibernation module in Run mode. When enabled, the module is provided a clock and accesses to module registers are allowed. When disabled, the clock is disabled to save power and accesses to module registers generate a bus fault.

Important: This register should be used to control the clocking for the Hibernation module.

Hibernation Run Mode Clock Gating Control (RCGCHIB)

Base 0x400F.E000
 Offset 0x614
 Type RW, reset 0x0000.0001

	31	30	29	28	27	26	25	24	23	22	21	20	19	18	17	16
	reserved															
Type	RO	RO	RO	RO	RO	RO	RO	RO	RO	RO	RO	RO	RO	RO	RO	RO
Reset	0	0	0	0	0	0	0	0	0	0	0	0	0	0	0	0
	15	14	13	12	11	10	9	8	7	6	5	4	3	2	1	0
	reserved															RO
Type	RO	RO	RO	RO	RO	RO	RO	RO	RO	RO	RO	RO	RO	RO	RO	RW
Reset	0	0	0	0	0	0	0	0	0	0	0	0	0	0	0	1

Bit/Field	Name	Type	Reset	Description
31:1	reserved	RO	0	Software should not rely on the value of a reserved bit. To provide compatibility with future products, the value of a reserved bit should be preserved across a read-modify-write operation.
0	R0	RW	1	Hibernation Module Run Mode Clock Gating Control
				Value Description
				0 Hibernation module is disabled.
				1 Enable and provide a clock to the Hibernation module in Run mode.

Register 93: Universal Asynchronous Receiver/Transmitter Run Mode Clock Gating Control (RCGCUART), offset 0x618

The **RCGCUART** register provides software the capability to enable and disable the UART modules in Run mode. When enabled, a module is provided a clock and accesses to module registers are allowed. When disabled, the clock is disabled to save power and accesses to module registers generate a bus fault.

Important: This register should be used to control the clocking for the UART modules.

Universal Asynchronous Receiver/Transmitter Run Mode Clock Gating Control (RCGCUART)

Base 0x400F.E000
Offset 0x618
Type RW, reset 0x0000.0000

	31	30	29	28	27	26	25	24	23	22	21	20	19	18	17	16
	reserved															
Type	RO	RO	RO	RO	RO	RO	RO	RO	RO	RO	RO	RO	RO	RO	RO	RO
Reset	0	0	0	0	0	0	0	0	0	0	0	0	0	0	0	0
	15	14	13	12	11	10	9	8	7	6	5	4	3	2	1	0
	reserved								R7	R6	R5	R4	R3	R2	R1	R0
Type	RO	RO	RO	RO	RO	RO	RO	RO	RW	RW	RW	RW	RW	RW	RW	RW
Reset	0	0	0	0	0	0	0	0	0	0	0	0	0	0	0	0

Bit/Field	Name	Type	Reset	Description
31:8	reserved	RO	0	Software should not rely on the value of a reserved bit. To provide compatibility with future products, the value of a reserved bit should be preserved across a read-modify-write operation.
7	R7	RW	0	UART Module 7 Run Mode Clock Gating Control Value Description 0 UART module 7 is disabled. 1 Enable and provide a clock to UART module 7 in Run mode.
6	R6	RW	0	UART Module 6 Run Mode Clock Gating Control Value Description 0 UART module 6 is disabled. 1 Enable and provide a clock to UART module 6 in Run mode.
5	R5	RW	0	UART Module 5 Run Mode Clock Gating Control Value Description 0 UART module 5 is disabled. 1 Enable and provide a clock to UART module 5 in Run mode.
4	R4	RW	0	UART Module 4 Run Mode Clock Gating Control Value Description 0 UART module 4 is disabled. 1 Enable and provide a clock to UART module 4 in Run mode.

Bit/Field	Name	Type	Reset	Description
3	R3	RW	0	UART Module 3 Run Mode Clock Gating Control Value Description 0 UART module 3 is disabled. 1 Enable and provide a clock to UART module 3 in Run mode.
2	R2	RW	0	UART Module 2 Run Mode Clock Gating Control Value Description 0 UART module 2 is disabled. 1 Enable and provide a clock to UART module 2 in Run mode.
1	R1	RW	0	UART Module 1 Run Mode Clock Gating Control Value Description 0 UART module 1 is disabled. 1 Enable and provide a clock to UART module 1 in Run mode.
0	R0	RW	0	UART Module 0 Run Mode Clock Gating Control Value Description 0 UART module 0 is disabled. 1 Enable and provide a clock to UART module 0 in Run mode.

Register 94: Synchronous Serial Interface Run Mode Clock Gating Control (RCGCSSI), offset 0x61C

The **RCGCSSI** register provides software the capability to enable and disable the SSI modules in Run mode. When enabled, a module is provided a clock and accesses to module registers are allowed. When disabled, the clock is disabled to save power and accesses to module registers generate a bus fault.

Important: This register should be used to control the clocking for the SSI modules.

Synchronous Serial Interface Run Mode Clock Gating Control (RCGCSSI)

Base 0x400F.E000
Offset 0x61C
Type RW, reset 0x0000.0000

	31	30	29	28	27	26	25	24	23	22	21	20	19	18	17	16
	reserved															
Type	RO	RO	RO	RO	RO	RO	RO	RO	RO	RO	RO	RO	RO	RO	RO	RO
Reset	0	0	0	0	0	0	0	0	0	0	0	0	0	0	0	0
	15	14	13	12	11	10	9	8	7	6	5	4	3	2	1	0
	reserved												R3	R2	R1	R0
Type	RO	RO	RO	RO	RO	RO	RO	RO	RO	RO	RO	RO	RW	RW	RW	RW
Reset	0	0	0	0	0	0	0	0	0	0	0	0	0	0	0	0

Bit/Field	Name	Type	Reset	Description
31:4	reserved	RO	0	Software should not rely on the value of a reserved bit. To provide compatibility with future products, the value of a reserved bit should be preserved across a read-modify-write operation.
3	R3	RW	0	SSI Module 3 Run Mode Clock Gating Control Value Description 0 SSI module 3 is disabled. 1 Enable and provide a clock to SSI module 3 in Run mode.
2	R2	RW	0	SSI Module 2 Run Mode Clock Gating Control Value Description 0 SSI module 2 is disabled. 1 Enable and provide a clock to SSI module 2 in Run mode.
1	R1	RW	0	SSI Module 1 Run Mode Clock Gating Control Value Description 0 SSI module 1 is disabled. 1 Enable and provide a clock to SSI module 1 in Run mode.
0	R0	RW	0	SSI Module 0 Run Mode Clock Gating Control Value Description 0 SSI module 0 is disabled. 1 Enable and provide a clock to SSI module 0 in Run mode.

Register 95: Inter-Integrated Circuit Run Mode Clock Gating Control (RCGCI2C), offset 0x620

The **RCGCI2C** register provides software the capability to enable and disable the I²C modules in Run mode. When enabled, a module is provided a clock and accesses to module registers are allowed. When disabled, the clock is disabled to save power and accesses to module registers generate a bus fault.

Important: This register should be used to control the clocking for the I²C modules.

Inter-Integrated Circuit Run Mode Clock Gating Control (RCGCI2C)

Base 0x400F.E000
 Offset 0x620
 Type RW, reset 0x0000.0000

	31	30	29	28	27	26	25	24	23	22	21	20	19	18	17	16
	reserved															
Type	RO	RO	RO	RO	RO	RO	RO	RO	RO	RO	RO	RO	RO	RO	RO	RO
Reset	0	0	0	0	0	0	0	0	0	0	0	0	0	0	0	0
	15	14	13	12	11	10	9	8	7	6	5	4	3	2	1	0
	reserved						R9	R8	R7	R6	R5	R4	R3	R2	R1	R0
Type	RO	RO	RO	RO	RO	RO	RW	RW	RW	RW	RW	RW	RW	RW	RW	RW
Reset	0	0	0	0	0	0	0	0	0	0	0	0	0	0	0	0

Bit/Field	Name	Type	Reset	Description
31:10	reserved	RO	0	Software should not rely on the value of a reserved bit. To provide compatibility with future products, the value of a reserved bit should be preserved across a read-modify-write operation.
9	R9	RW	0	I ² C Module 9 Run Mode Clock Gating Control Value Description 0 I ² C module 9 is disabled. 1 Enable and provide a clock to I ² C module 9 in Run mode.
8	R8	RW	0	I ² C Module 8 Run Mode Clock Gating Control Value Description 0 I ² C module 8 is disabled. 1 Enable and provide a clock to I ² C module 8 in Run mode.
7	R7	RW	0	I ² C Module 7 Run Mode Clock Gating Control Value Description 0 I ² C module 7 is disabled. 1 Enable and provide a clock to I ² C module 7 in Run mode.

Bit/Field	Name	Type	Reset	Description
6	R6	RW	0	I ² C Module 6 Run Mode Clock Gating Control Value Description 0 I ² C module 6 is disabled. 1 Enable and provide a clock to I ² C module 6 in Run mode.
5	R5	RW	0	I ² C Module 5 Run Mode Clock Gating Control Value Description 0 I ² C module 5 is disabled. 1 Enable and provide a clock to I ² C module 5 in Run mode.
4	R4	RW	0	I ² C Module 4 Run Mode Clock Gating Control Value Description 0 I ² C module 4 is disabled. 1 Enable and provide a clock to I ² C module 4 in Run mode.
3	R3	RW	0	I ² C Module 3 Run Mode Clock Gating Control Value Description 0 I ² C module 3 is disabled. 1 Enable and provide a clock to I ² C module 3 in Run mode.
2	R2	RW	0	I ² C Module 2 Run Mode Clock Gating Control Value Description 0 I ² C module 2 is disabled. 1 Enable and provide a clock to I ² C module 2 in Run mode.
1	R1	RW	0	I ² C Module 1 Run Mode Clock Gating Control Value Description 0 I ² C module 1 is disabled. 1 Enable and provide a clock to I ² C module 1 in Run mode.
0	R0	RW	0	I ² C Module 0 Run Mode Clock Gating Control Value Description 0 I ² C module 0 is disabled. 1 Enable and provide a clock to I ² C module 0 in Run mode.

Register 96: Universal Serial Bus Run Mode Clock Gating Control (RCGCUSB), offset 0x628

The **RCGCUSB** register provides software the capability to enable and disable the USB module in Run mode. When enabled, the module is provided a clock and accesses to module registers are allowed. When disabled, the clock is disabled to save power and accesses to module registers generate a bus fault.

Important: This register should be used to control the clocking for the USB module.

Universal Serial Bus Run Mode Clock Gating Control (RCGCUSB)

Base 0x400F.E000
 Offset 0x628
 Type RW, reset 0x0000.0000

	31	30	29	28	27	26	25	24	23	22	21	20	19	18	17	16
	reserved															
Type	RO	RO	RO	RO	RO	RO	RO	RO	RO	RO	RO	RO	RO	RO	RO	RO
Reset	0	0	0	0	0	0	0	0	0	0	0	0	0	0	0	0
	15	14	13	12	11	10	9	8	7	6	5	4	3	2	1	0
	reserved															RO
Type	RO	RO	RO	RO	RO	RO	RO	RO	RO	RO	RO	RO	RO	RO	RO	RW
Reset	0	0	0	0	0	0	0	0	0	0	0	0	0	0	0	0

Bit/Field	Name	Type	Reset	Description
31:1	reserved	RO	0	Software should not rely on the value of a reserved bit. To provide compatibility with future products, the value of a reserved bit should be preserved across a read-modify-write operation.
0	R0	RW	0	USB Module Run Mode Clock Gating Control
				Value Description
				0 USB module is disabled.
				1 Enable and provide a clock to the USB module in Run mode.

Register 97: Ethernet PHY Run Mode Clock Gating Control (RCGCEPHY), offset 0x630

The **RCGCEPHY** register provides software the capability to enable and disable the PHY module in Run mode. When enabled, the module is provided a clock and accesses to module registers are allowed. When disabled, the clock is disabled to save power and accesses to module registers generate a bus fault.

Important: This register should be used to control the clocking for the PHY module.

Ethernet PHY Run Mode Clock Gating Control (RCGCEPHY)

Base 0x400F.E000

Offset 0x630

Type RW, reset 0x0000.0000

	31	30	29	28	27	26	25	24	23	22	21	20	19	18	17	16
	reserved															
Type	RO	RO	RO	RO	RO	RO	RO	RO	RO	RO	RO	RO	RO	RO	RO	RO
Reset	0	0	0	0	0	0	0	0	0	0	0	0	0	0	0	0
	15	14	13	12	11	10	9	8	7	6	5	4	3	2	1	0
	reserved															RO
Type	RO	RO	RO	RO	RO	RO	RO	RO	RO	RO	RO	RO	RO	RO	RO	RW
Reset	0	0	0	0	0	0	0	0	0	0	0	0	0	0	0	0

Bit/Field	Name	Type	Reset	Description
31:1	reserved	RO	0	Software should not rely on the value of a reserved bit. To provide compatibility with future products, the value of a reserved bit should be preserved across a read-modify-write operation.
0	R0	RW	0	Ethernet PHY Module Run Mode Clock Gating Control
	Value	Description		
	0	PHY module is disabled.		
	1	Enable and provide a clock to the PHY module in Run mode.		

Register 98: Controller Area Network Run Mode Clock Gating Control (RCGCCAN), offset 0x634

The **RCGCCAN** register provides software the capability to enable and disable the CAN modules in Run mode. When enabled, a module is provided a clock and accesses to module registers are allowed. When disabled, the clock is disabled to save power and accesses to module registers generate a bus fault.

Important: This register should be used to control the clocking for the CAN modules.

Controller Area Network Run Mode Clock Gating Control (RCGCCAN)

Base 0x400F.E000
 Offset 0x634
 Type RW, reset 0x0000.0000

	31	30	29	28	27	26	25	24	23	22	21	20	19	18	17	16	
	reserved																
Type	RO	RO	RO	RO	RO	RO	RO	RO	RO	RO	RO	RO	RO	RO	RO	RO	
Reset	0	0	0	0	0	0	0	0	0	0	0	0	0	0	0	0	
	15	14	13	12	11	10	9	8	7	6	5	4	3	2	1	0	
	reserved															R1	R0
Type	RO	RO	RO	RO	RO	RO	RO	RO	RO	RO	RO	RO	RO	RO	RO	RW	RW
Reset	0	0	0	0	0	0	0	0	0	0	0	0	0	0	0	0	0

Bit/Field	Name	Type	Reset	Description
31:2	reserved	RO	0	Software should not rely on the value of a reserved bit. To provide compatibility with future products, the value of a reserved bit should be preserved across a read-modify-write operation.
1	R1	RW	0	CAN Module 1 Run Mode Clock Gating Control Value Description 0 CAN module 1 is disabled. 1 Enable and provide a clock to CAN module 1 in Run mode.
0	R0	RW	0	CAN Module 0 Run Mode Clock Gating Control Value Description 0 CAN module 0 is disabled. 1 Enable and provide a clock to CAN module 0 in Run mode.

Register 99: Analog-to-Digital Converter Run Mode Clock Gating Control (RCGCADC), offset 0x638

The **RCGCADC** register provides software the capability to enable and disable the ADC modules in Run mode. When enabled, a module is provided a clock and accesses to module registers are allowed. When disabled, the clock is disabled to save power and accesses to module registers generate a bus fault.

Important: This register should be used to control the clocking for the ADC modules.

Analog-to-Digital Converter Run Mode Clock Gating Control (RCGCADC)

Base 0x400F.E000

Offset 0x638

Type RW, reset 0x0000.0000

	31	30	29	28	27	26	25	24	23	22	21	20	19	18	17	16	
	reserved																
Type	RO	RO	RO	RO	RO	RO	RO	RO	RO	RO	RO	RO	RO	RO	RO	RO	
Reset	0	0	0	0	0	0	0	0	0	0	0	0	0	0	0	0	
	15	14	13	12	11	10	9	8	7	6	5	4	3	2	1	0	
	reserved															R1	R0
Type	RO	RO	RO	RO	RO	RO	RO	RO	RO	RO	RO	RO	RO	RO	RW	RW	
Reset	0	0	0	0	0	0	0	0	0	0	0	0	0	0	0	0	

Bit/Field	Name	Type	Reset	Description
31:2	reserved	RO	0	Software should not rely on the value of a reserved bit. To provide compatibility with future products, the value of a reserved bit should be preserved across a read-modify-write operation.
1	R1	RW	0	ADC Module 1 Run Mode Clock Gating Control Value Description 0 ADC module 1 is disabled. 1 Enable and provide a clock to ADC module 1 in Run mode.
0	R0	RW	0	ADC Module 0 Run Mode Clock Gating Control Value Description 0 ADC module 0 is disabled. 1 Enable and provide a clock to ADC module 0 in Run mode.

Register 100: Analog Comparator Run Mode Clock Gating Control (RCGCACMP), offset 0x63C

The **RCGCACMP** register provides software the capability to enable and disable the analog comparator module in Run mode. When enabled, the module is provided a clock and accesses to module registers are allowed. When disabled, the clock is disabled to save power and accesses to module registers generate a bus fault.

Important: This register should be used to control the clocking for the analog comparator module.

Analog Comparator Run Mode Clock Gating Control (RCGCACMP)

Base 0x400F.E000
 Offset 0x63C
 Type RW, reset 0x0000.0000

	31	30	29	28	27	26	25	24	23	22	21	20	19	18	17	16
	reserved															
Type	RO	RO	RO	RO	RO	RO	RO	RO	RO	RO	RO	RO	RO	RO	RO	RO
Reset	0	0	0	0	0	0	0	0	0	0	0	0	0	0	0	0
	15	14	13	12	11	10	9	8	7	6	5	4	3	2	1	0
	reserved															RO
Type	RO	RO	RO	RO	RO	RO	RO	RO	RO	RO	RO	RO	RO	RO	RO	RW
Reset	0	0	0	0	0	0	0	0	0	0	0	0	0	0	0	0

Bit/Field	Name	Type	Reset	Description
31:1	reserved	RO	0	Software should not rely on the value of a reserved bit. To provide compatibility with future products, the value of a reserved bit should be preserved across a read-modify-write operation.
0	R0	RW	0	Analog Comparator Module 0 Run Mode Clock Gating Control
				Value Description
				0 Analog comparator module is disabled.
				1 Enable and provide a clock to the analog comparator module in Run mode.

Register 101: Pulse Width Modulator Run Mode Clock Gating Control (RCGCPWM), offset 0x640

The **RCGCPWM** register provides software the capability to enable and disable the PWM modules in Run mode. When enabled, a module is provided a clock and accesses to module registers are allowed. When disabled, the clock is disabled to save power and accesses to module registers generate a bus fault.

Important: This register should be used to control the clocking for the PWM modules.

Pulse Width Modulator Run Mode Clock Gating Control (RCGCPWM)

Base 0x400F.E000

Offset 0x640

Type RW, reset 0x0000.0000

	31	30	29	28	27	26	25	24	23	22	21	20	19	18	17	16
	reserved															
Type	RO	RO	RO	RO	RO	RO	RO	RO	RO	RO	RO	RO	RO	RO	RO	RO
Reset	0	0	0	0	0	0	0	0	0	0	0	0	0	0	0	0
	15	14	13	12	11	10	9	8	7	6	5	4	3	2	1	0
	reserved															RO
Type	RO	RO	RO	RO	RO	RO	RO	RO	RO	RO	RO	RO	RO	RO	RO	RW
Reset	0	0	0	0	0	0	0	0	0	0	0	0	0	0	0	0

Bit/Field	Name	Type	Reset	Description
31:1	reserved	RO	0	Software should not rely on the value of a reserved bit. To provide compatibility with future products, the value of a reserved bit should be preserved across a read-modify-write operation.
0	R0	RW	0	PWM Module 0 Run Mode Clock Gating Control
				Value Description
			0	PWM module 0 is disabled.
			1	Enable and provide a clock to PWM module 0 in Run mode.

Register 102: Quadrature Encoder Interface Run Mode Clock Gating Control (RCGCQEI), offset 0x644

The **RCGCQEI** register provides software the capability to enable and disable the QEI modules in Run mode. When enabled, a module is provided a clock and accesses to module registers are allowed. When disabled, the clock is disabled to save power and accesses to module registers generate a bus fault.

Important: This register should be used to control the clocking for the QEI modules.

Quadrature Encoder Interface Run Mode Clock Gating Control (RCGCQEI)

Base 0x400F.E000
 Offset 0x644
 Type RW, reset 0x0000.0000

	31	30	29	28	27	26	25	24	23	22	21	20	19	18	17	16
	reserved															
Type	RO	RO	RO	RO	RO	RO	RO	RO	RO	RO	RO	RO	RO	RO	RO	RO
Reset	0	0	0	0	0	0	0	0	0	0	0	0	0	0	0	0
	15	14	13	12	11	10	9	8	7	6	5	4	3	2	1	0
	reserved															
Type	RO	RO	RO	RO	RO	RO	RO	RO	RO	RO	RO	RO	RO	RO	RO	R0
Reset	0	0	0	0	0	0	0	0	0	0	0	0	0	0	0	0

Bit/Field	Name	Type	Reset	Description
31:1	reserved	RO	0	Software should not rely on the value of a reserved bit. To provide compatibility with future products, the value of a reserved bit should be preserved across a read-modify-write operation.
0	R0	RW	0	QEI Module 0 Run Mode Clock Gating Control
				Value Description
			0	QEI module 0 is disabled.
			1	Enable and provide a clock to QEI module 0 in Run mode.

Register 103: EEPROM Run Mode Clock Gating Control (RCGCEEPROM), offset 0x658

The **RCGCEEPROM** register provides software the capability to enable and disable the EEPROM module in Run mode. When enabled, the module is provided a clock and accesses to module registers are allowed. When disabled, the clock is disabled to save power and accesses to module registers generate a bus fault.

EEPROM Run Mode Clock Gating Control (RCGCEEPROM)

Base 0x400F.E000

Offset 0x658

Type RW, reset 0x0000.0000

	31	30	29	28	27	26	25	24	23	22	21	20	19	18	17	16
	reserved															
Type	RO	RO	RO	RO	RO	RO	RO	RO	RO	RO	RO	RO	RO	RO	RO	RO
Reset	0	0	0	0	0	0	0	0	0	0	0	0	0	0	0	0
	15	14	13	12	11	10	9	8	7	6	5	4	3	2	1	0
	reserved															RO
Type	RO	RO	RO	RO	RO	RO	RO	RO	RO	RO	RO	RO	RO	RO	RO	RW
Reset	0	0	0	0	0	0	0	0	0	0	0	0	0	0	0	0

Bit/Field	Name	Type	Reset	Description
31:1	reserved	RO	0	Software should not rely on the value of a reserved bit. To provide compatibility with future products, the value of a reserved bit should be preserved across a read-modify-write operation.
0	R0	RW	0	EEPROM Module 0 Run Mode Clock Gating Control
Value Description				
	0			EEPROM module is disabled.
	1			Enable and provide a clock to the EEPROM module in Run mode.

Register 104: CRC and Cryptographic Modules Run Mode Clock Gating Control (RCGCCCM), offset 0x674

The **RCGCCCM** register provides software the capability to enable and disable the CRC and Encryption Modules (AES, DES, and SHA/MD5) in Run mode. When enabled, the modules are provided a clock and accesses to module registers are allowed. When disabled, the clock is disabled to save power and accesses to module registers generate a bus fault.

Important: This register should be used to control the clocking for the CRC, AES, DES, and SHA/MD5 modules.

CRC and Cryptographic Modules Run Mode Clock Gating Control (RCGCCCM)

Base 0x400F.E000
 Offset 0x674
 Type RW, reset 0x0000.0000

	31	30	29	28	27	26	25	24	23	22	21	20	19	18	17	16
	reserved															
Type	RO	RO	RO	RO	RO	RO	RO	RO	RO	RO	RO	RO	RO	RO	RO	RO
Reset	0	0	0	0	0	0	0	0	0	0	0	0	0	0	0	0
	15	14	13	12	11	10	9	8	7	6	5	4	3	2	1	0
	reserved															RO
Type	RO	RO	RO	RO	RO	RO	RO	RO	RO	RO	RO	RO	RO	RO	RO	RW
Reset	0	0	0	0	0	0	0	0	0	0	0	0	0	0	0	0

Bit/Field	Name	Type	Reset	Description
31:1	reserved	RO	0	Software should not rely on the value of a reserved bit. To provide compatibility with future products, the value of a reserved bit should be preserved across a read-modify-write operation.
0	R0	RW	0	CRC and Cryptographic Modules Run Mode Clock Gating Control
				Value Description
				0 The CRC, AES, DES, and SHA/MD5 modules are disabled.
				1 Enable and provide a clock to the CRC, AES, DES, and SHA/MD5 modules in Run mode.

Register 105: Ethernet MAC Run Mode Clock Gating Control (RCGCEMAC), offset 0x69C

The **RCGCEMAC** register provides software the capability to enable and disable the Ethernet MAC module in Run mode. When enabled, a module is provided a clock and accesses to module registers are allowed. When disabled, the clock is disabled to save power and accesses to module registers generate a bus fault.

Important: This register should be used to control the clocking for the Ethernet Controller module.

Ethernet MAC Run Mode Clock Gating Control (RCGCEMAC)

Base 0x400F.E000

Offset 0x69C

Type RW, reset 0x0000.0000

	31	30	29	28	27	26	25	24	23	22	21	20	19	18	17	16
	reserved															
Type	RO	RO	RO	RO	RO	RO	RO	RO	RO	RO	RO	RO	RO	RO	RO	RO
Reset	0	0	0	0	0	0	0	0	0	0	0	0	0	0	0	0
	15	14	13	12	11	10	9	8	7	6	5	4	3	2	1	0
	reserved															RO
Type	RO	RO	RO	RO	RO	RO	RO	RO	RO	RO	RO	RO	RO	RO	RO	RW
Reset	0	0	0	0	0	0	0	0	0	0	0	0	0	0	0	0

Bit/Field	Name	Type	Reset	Description
31:1	reserved	RO	0	Software should not rely on the value of a reserved bit. To provide compatibility with future products, the value of a reserved bit should be preserved across a read-modify-write operation.
0	R0	RW	0	Ethernet MAC Module 0 Run Mode Clock Gating Control
				Value Description
			0	Ethernet MAC module 0 is disabled.
			1	Enable and provide a clock to Ethernet MAC module 0 in Run mode.

Register 106: Watchdog Timer Sleep Mode Clock Gating Control (SCGCWD), offset 0x700

The **SCGCWD** register provides software the capability to enable and disable watchdog modules in sleep mode. When enabled, a module is provided a clock. When disabled, the clock is disabled to save power.

Important: This register should be used to control the clocking for the watchdog modules.

Watchdog Timer Sleep Mode Clock Gating Control (SCGCWD)

Base 0x400F.E000
 Offset 0x700
 Type RW, reset 0x0000.0000

	31	30	29	28	27	26	25	24	23	22	21	20	19	18	17	16
	reserved															
Type	RO	RO	RO	RO	RO	RO	RO	RO	RO	RO	RO	RO	RO	RO	RO	RO
Reset	0	0	0	0	0	0	0	0	0	0	0	0	0	0	0	0
	15	14	13	12	11	10	9	8	7	6	5	4	3	2	1	0
	reserved														S1	S0
Type	RO	RO	RO	RO	RO	RO	RO	RO	RO	RO	RO	RO	RO	RO	RW	RW
Reset	0	0	0	0	0	0	0	0	0	0	0	0	0	0	0	0

Bit/Field	Name	Type	Reset	Description
31:2	reserved	RO	0	Software should not rely on the value of a reserved bit. To provide compatibility with future products, the value of a reserved bit should be preserved across a read-modify-write operation.
1	S1	RW	0	Watchdog Timer 1 Sleep Mode Clock Gating Control Value Description 0 Watchdog module 1 is disabled in sleep mode. 1 Enable and provide a clock to Watchdog module 1 in sleep mode.
0	S0	RW	0	Watchdog Timer 0 Sleep Mode Clock Gating Control Value Description 0 Watchdog module 0 is disabled in sleep mode. 1 Enable and provide a clock to Watchdog module 0 in sleep mode.

Register 107: 16/32-Bit General-Purpose Timer Sleep Mode Clock Gating Control (SCGCTIMER), offset 0x704

The **SCGCGPT32** register provides software the capability to enable and disable 16/32-bit timer modules in sleep mode. When enabled, a module is provided a clock. When disabled, the clock is disabled to save power.

Important: This register should be used to control the clocking for the timer modules.

16/32-Bit General-Purpose Timer Sleep Mode Clock Gating Control (SCGCTIMER)

Base 0x400F.E000

Offset 0x704

Type RW, reset 0x0000.0000

	31	30	29	28	27	26	25	24	23	22	21	20	19	18	17	16
	reserved															
Type	RO	RO	RO	RO	RO	RO	RO	RO	RO	RO	RO	RO	RO	RO	RO	RO
Reset	0	0	0	0	0	0	0	0	0	0	0	0	0	0	0	0
	15	14	13	12	11	10	9	8	7	6	5	4	3	2	1	0
	reserved								S7	S6	S5	S4	S3	S2	S1	S0
Type	RO	RO	RO	RO	RO	RO	RO	RO	RW	RW	RW	RW	RW	RW	RW	RW
Reset	0	0	0	0	0	0	0	0	0	0	0	0	0	0	0	0

Bit/Field	Name	Type	Reset	Description
31:8	reserved	RO	0	Software should not rely on the value of a reserved bit. To provide compatibility with future products, the value of a reserved bit should be preserved across a read-modify-write operation.
7	S7	RW	0	16/32-Bit General-Purpose Timer 7 Sleep Mode Clock Gating Control Value Description 0 16/32-bit general-purpose timer module 7 is disabled in sleep mode. 1 Enable and provide a clock to 16/32-bit general-purpose timer module 7 in sleep mode.
6	S6	RW	0	16/32-Bit General-Purpose Timer 6 Sleep Mode Clock Gating Control Value Description 0 16/32-bit general-purpose timer module 6 is disabled in sleep mode. 1 Enable and provide a clock to 16/32-bit general-purpose timer module 6 in sleep mode.
5	S5	RW	0	16/32-Bit General-Purpose Timer 5 Sleep Mode Clock Gating Control Value Description 0 16/32-bit general-purpose timer module 5 is disabled in sleep mode. 1 Enable and provide a clock to 16/32-bit general-purpose timer module 5 in sleep mode.

Bit/Field	Name	Type	Reset	Description
4	S4	RW	0	<p>16/32-Bit General-Purpose Timer 4 Sleep Mode Clock Gating Control</p> <p>Value Description</p> <p>0 16/32-bit general-purpose timer module 4 is disabled in sleep mode.</p> <p>1 Enable and provide a clock to 16/32-bit general-purpose timer module 4 in sleep mode.</p>
3	S3	RW	0	<p>16/32-Bit General-Purpose Timer 3 Sleep Mode Clock Gating Control</p> <p>Value Description</p> <p>0 16/32-bit general-purpose timer module 3 is disabled in sleep mode.</p> <p>1 Enable and provide a clock to 16/32-bit general-purpose timer module 3 in sleep mode.</p>
2	S2	RW	0	<p>16/32-Bit General-Purpose Timer 2 Sleep Mode Clock Gating Control</p> <p>Value Description</p> <p>0 16/32-bit general-purpose timer module 2 is disabled in sleep mode.</p> <p>1 Enable and provide a clock to 16/32-bit general-purpose timer module 2 in sleep mode.</p>
1	S1	RW	0	<p>16/32-Bit General-Purpose Timer 1 Sleep Mode Clock Gating Control</p> <p>Value Description</p> <p>0 16/32-bit general-purpose timer module 1 is disabled in sleep mode.</p> <p>1 Enable and provide a clock to 16/32-bit general-purpose timer module 1 in sleep mode.</p>
0	S0	RW	0	<p>16/32-Bit General-Purpose Timer 0 Sleep Mode Clock Gating Control</p> <p>Value Description</p> <p>0 16/32-bit general-purpose timer module 0 is disabled in sleep mode.</p> <p>1 Enable and provide a clock to 16/32-bit general-purpose timer module 0 in sleep mode.</p>

Register 108: General-Purpose Input/Output Sleep Mode Clock Gating Control (SCGCGPIO), offset 0x708

The **SCGCGPIO** register provides software the capability to enable and disable GPIO modules in sleep mode. When enabled, a module is provided a clock. When disabled, the clock is disabled to save power.

Important: This register should be used to control the clocking for the GPIO modules.

General-Purpose Input/Output Sleep Mode Clock Gating Control (SCGCGPIO)

Base 0x400F.E000

Offset 0x708

Type RW, reset 0x0000.0000

	31	30	29	28	27	26	25	24	23	22	21	20	19	18	17	16
	reserved															
Type	RO	RO	RO	RO	RO	RO	RO	RO	RO	RO	RO	RO	RO	RO	RO	RO
Reset	0	0	0	0	0	0	0	0	0	0	0	0	0	0	0	0
	15	14	13	12	11	10	9	8	7	6	5	4	3	2	1	0
	reserved	S14	S13	S12	S11	S10	S9	S8	S7	S6	S5	S4	S3	S2	S1	S0
Type	RO	RW	RW	RW	RW	RW	RW	RW	RW	RW	RW	RW	RW	RW	RW	RW
Reset	0	0	0	0	0	0	0	0	0	0	0	0	0	0	0	0

Bit/Field	Name	Type	Reset	Description
31:15	reserved	RO	0	Software should not rely on the value of a reserved bit. To provide compatibility with future products, the value of a reserved bit should be preserved across a read-modify-write operation.
14	S14	RW	0	GPIO Port Q Sleep Mode Clock Gating Control Value Description 0 GPIO Port Q is disabled in sleep mode. 1 Enable and provide a clock to GPIO Port Q in sleep mode.
13	S13	RW	0	GPIO Port P Sleep Mode Clock Gating Control Value Description 0 GPIO Port P is disabled in sleep mode. 1 Enable and provide a clock to GPIO Port P in sleep mode.
12	S12	RW	0	GPIO Port N Sleep Mode Clock Gating Control Value Description 0 GPIO Port N is disabled in sleep mode. 1 Enable and provide a clock to GPIO Port N in sleep mode.
11	S11	RW	0	GPIO Port M Sleep Mode Clock Gating Control Value Description 0 GPIO Port M is disabled in sleep mode. 1 Enable and provide a clock to GPIO Port M in sleep mode.

Bit/Field	Name	Type	Reset	Description
10	S10	RW	0	GPIO Port L Sleep Mode Clock Gating Control Value Description 0 GPIO Port L is disabled in sleep mode. 1 Enable and provide a clock to GPIO Port L in sleep mode.
9	S9	RW	0	GPIO Port K Sleep Mode Clock Gating Control Value Description 0 GPIO Port K is disabled in sleep mode. 1 Enable and provide a clock to GPIO Port K in sleep mode.
8	S8	RW	0	GPIO Port J Sleep Mode Clock Gating Control Value Description 0 GPIO Port J is disabled in sleep mode. 1 Enable and provide a clock to GPIO Port J in sleep mode.
7	S7	RW	0	GPIO Port H Sleep Mode Clock Gating Control Value Description 0 GPIO Port H is disabled in sleep mode. 1 Enable and provide a clock to GPIO Port H in sleep mode.
6	S6	RW	0	GPIO Port G Sleep Mode Clock Gating Control Value Description 0 GPIO Port G is disabled in sleep mode. 1 Enable and provide a clock to GPIO Port G in sleep mode.
5	S5	RW	0	GPIO Port F Sleep Mode Clock Gating Control Value Description 0 GPIO Port F is disabled in sleep mode. 1 Enable and provide a clock to GPIO Port F in sleep mode.
4	S4	RW	0	GPIO Port E Sleep Mode Clock Gating Control Value Description 0 GPIO Port E is disabled in sleep mode. 1 Enable and provide a clock to GPIO Port E in sleep mode.

Bit/Field	Name	Type	Reset	Description
3	S3	RW	0	GPIO Port D Sleep Mode Clock Gating Control Value Description 0 GPIO Port D is disabled in sleep mode. 1 Enable and provide a clock to GPIO Port D in sleep mode.
2	S2	RW	0	GPIO Port C Sleep Mode Clock Gating Control Value Description 0 GPIO Port C is disabled in sleep mode. 1 Enable and provide a clock to GPIO Port C in sleep mode.
1	S1	RW	0	GPIO Port B Sleep Mode Clock Gating Control Value Description 0 GPIO Port B is disabled in sleep mode. 1 Enable and provide a clock to GPIO Port B in sleep mode.
0	S0	RW	0	GPIO Port A Sleep Mode Clock Gating Control Value Description 0 GPIO Port A is disabled in sleep mode. 1 Enable and provide a clock to GPIO Port A in sleep mode.

Register 109: Micro Direct Memory Access Sleep Mode Clock Gating Control (SCGCDMA), offset 0x70C

The **SCGCDMA** register provides software the capability to enable and disable the μ DMA module in sleep mode. When enabled, a module is provided a clock. When disabled, the clock is disabled to save power.

Important: This register should be used to control the clocking for the μ DMA module.

Micro Direct Memory Access Sleep Mode Clock Gating Control (SCGCDMA)

Base 0x400F.E000
 Offset 0x70C
 Type RW, reset 0x0000.0000

	31	30	29	28	27	26	25	24	23	22	21	20	19	18	17	16
	reserved															
Type	RO	RO	RO	RO	RO	RO	RO	RO	RO	RO	RO	RO	RO	RO	RO	RO
Reset	0	0	0	0	0	0	0	0	0	0	0	0	0	0	0	0
	15	14	13	12	11	10	9	8	7	6	5	4	3	2	1	0
	reserved															S0
Type	RO	RO	RO	RO	RO	RO	RO	RO	RO	RO	RO	RO	RO	RO	RO	RW
Reset	0	0	0	0	0	0	0	0	0	0	0	0	0	0	0	0

Bit/Field	Name	Type	Reset	Description
31:1	reserved	RO	0	Software should not rely on the value of a reserved bit. To provide compatibility with future products, the value of a reserved bit should be preserved across a read-modify-write operation.
0	S0	RW	0	μ DMA Module Sleep Mode Clock Gating Control
				Value Description
				0 μ DMA module is disabled in sleep mode.
				1 Enable and provide a clock to the μ DMA module in sleep mode.

Register 110: EPI Sleep Mode Clock Gating Control (SCGCEPI), offset 0x710

The **SCGCEPI** register provides software the capability to enable and disable the EPI module in sleep mode. When enabled, a module is provided a clock. When disabled, the clock is disabled to save power.

Important: This register should be used to control the clocking for the EPI module.

EPI Sleep Mode Clock Gating Control (SCGCEPI)

Base 0x400F.E000

Offset 0x710

Type RW, reset 0x0000.0000

	31	30	29	28	27	26	25	24	23	22	21	20	19	18	17	16
	reserved															
Type	RO	RO	RO	RO	RO	RO	RO	RO	RO	RO	RO	RO	RO	RO	RO	RO
Reset	0	0	0	0	0	0	0	0	0	0	0	0	0	0	0	0
	15	14	13	12	11	10	9	8	7	6	5	4	3	2	1	0
	reserved															
Type	RO	RO	RO	RO	RO	RO	RO	RO	RO	RO	RO	RO	RO	RO	RO	RW
Reset	0	0	0	0	0	0	0	0	0	0	0	0	0	0	0	0

Bit/Field	Name	Type	Reset	Description
31:1	reserved	RO	0	Software should not rely on the value of a reserved bit. To provide compatibility with future products, the value of a reserved bit should be preserved across a read-modify-write operation.
0	S0	RW	0	EPI Module Sleep Mode Clock Gating Control
				Value Description
			0	EPI module is disabled in sleep mode.
			1	Enable and provide a clock to the EPI module in sleep mode.

Register 111: Hibernation Sleep Mode Clock Gating Control (SCGCHIB), offset 0x714

The **SCGCHIB** register provides software the capability to enable and disable the Hibernation module in sleep mode. When enabled, a module is provided a clock. When disabled, the clock is disabled to save power.

Important: This register should be used to control the clocking for the Hibernation module.

Hibernation Sleep Mode Clock Gating Control (SCGCHIB)

Base 0x400F.E000
 Offset 0x714
 Type RW, reset 0x0000.0001

	31	30	29	28	27	26	25	24	23	22	21	20	19	18	17	16
	reserved															
Type	RO	RO	RO	RO	RO	RO	RO	RO	RO	RO	RO	RO	RO	RO	RO	RO
Reset	0	0	0	0	0	0	0	0	0	0	0	0	0	0	0	0
	15	14	13	12	11	10	9	8	7	6	5	4	3	2	1	0
	reserved															S0
Type	RO	RO	RO	RO	RO	RO	RO	RO	RO	RO	RO	RO	RO	RO	RO	RW
Reset	0	0	0	0	0	0	0	0	0	0	0	0	0	0	0	1

Bit/Field	Name	Type	Reset	Description
31:1	reserved	RO	0	Software should not rely on the value of a reserved bit. To provide compatibility with future products, the value of a reserved bit should be preserved across a read-modify-write operation.
0	S0	RW	1	Hibernation Module Sleep Mode Clock Gating Control
				Value Description
				0 Hibernation module is disabled in sleep mode.
				1 Enable and provide a clock to the Hibernation module in sleep mode.

Register 112: Universal Asynchronous Receiver/Transmitter Sleep Mode Clock Gating Control (SCGCUART), offset 0x718

The **SCGCUART** register provides software the capability to enable and disable the UART modules in sleep mode. When enabled, a module is provided a clock. When disabled, the clock is disabled to save power.

Important: This register should be used to control the clocking for the UART modules.

Universal Asynchronous Receiver/Transmitter Sleep Mode Clock Gating Control (SCGCUART)

Base 0x400F.E000
Offset 0x718
Type RW, reset 0x0000.0000

	31	30	29	28	27	26	25	24	23	22	21	20	19	18	17	16
	reserved															
Type	RO	RO	RO	RO	RO	RO	RO	RO	RO	RO	RO	RO	RO	RO	RO	RO
Reset	0	0	0	0	0	0	0	0	0	0	0	0	0	0	0	0
	15	14	13	12	11	10	9	8	7	6	5	4	3	2	1	0
	reserved								S7	S6	S5	S4	S3	S2	S1	S0
Type	RO	RO	RO	RO	RO	RO	RO	RO	RW	RW	RW	RW	RW	RW	RW	RW
Reset	0	0	0	0	0	0	0	0	0	0	0	0	0	0	0	0

Bit/Field	Name	Type	Reset	Description
31:8	reserved	RO	0	Software should not rely on the value of a reserved bit. To provide compatibility with future products, the value of a reserved bit should be preserved across a read-modify-write operation.
7	S7	RW	0	UART Module 7 Sleep Mode Clock Gating Control Value Description 0 UART module 7 is disabled in sleep mode. 1 Enable and provide a clock to UART module 7 in sleep mode.
6	S6	RW	0	UART Module 6 Sleep Mode Clock Gating Control Value Description 0 UART module 6 is disabled in sleep mode. 1 Enable and provide a clock to UART module 6 in sleep mode.
5	S5	RW	0	UART Module 5 Sleep Mode Clock Gating Control Value Description 0 UART module 5 is disabled in sleep mode. 1 Enable and provide a clock to UART module 5 in sleep mode.
4	S4	RW	0	UART Module 4 Sleep Mode Clock Gating Control Value Description 0 UART module 4 is disabled. 1 Enable and provide a clock to UART module 4 in sleep mode.

Bit/Field	Name	Type	Reset	Description
3	S3	RW	0	UART Module 3 Sleep Mode Clock Gating Control Value Description 0 UART module 3 is disabled in sleep mode. 1 Enable and provide a clock to UART module 3 in sleep mode.
2	S2	RW	0	UART Module 2 Sleep Mode Clock Gating Control Value Description 0 UART module 2 is disabled in sleep mode. 1 Enable and provide a clock to UART module 2 in sleep mode.
1	S1	RW	0	UART Module 1 Sleep Mode Clock Gating Control Value Description 0 UART module 1 is disabled in sleep mode. 1 Enable and provide a clock to UART module 1 in sleep mode.
0	S0	RW	0	UART Module 0 Sleep Mode Clock Gating Control Value Description 0 UART module 0 is disabled. 1 Enable and provide a clock to UART module 0 in sleep mode.

Register 113: Synchronous Serial Interface Sleep Mode Clock Gating Control (SCGCSSI), offset 0x71C

The **SCGCSSI** register provides software the capability to enable and disable the SSI modules in sleep mode. When enabled, a module is provided a clock. When disabled, the clock is disabled to save power.

Important: This register should be used to control the clocking for the SSI modules.

Synchronous Serial Interface Sleep Mode Clock Gating Control (SCGCSSI)

Base 0x400F.E000
Offset 0x71C
Type RW, reset 0x0000.0000

	31	30	29	28	27	26	25	24	23	22	21	20	19	18	17	16	
	reserved																
Type	RO	RO	RO	RO	RO	RO	RO	RO	RO	RO	RO	RO	RO	RO	RO	RO	
Reset	0	0	0	0	0	0	0	0	0	0	0	0	0	0	0	0	
	15	14	13	12	11	10	9	8	7	6	5	4	3	2	1	0	
	reserved													S3	S2	S1	S0
Type	RO	RO	RO	RO	RO	RO	RO	RO	RO	RO	RO	RO	RO	RW	RW	RW	RW
Reset	0	0	0	0	0	0	0	0	0	0	0	0	0	0	0	0	0

Bit/Field	Name	Type	Reset	Description
31:4	reserved	RO	0	Software should not rely on the value of a reserved bit. To provide compatibility with future products, the value of a reserved bit should be preserved across a read-modify-write operation.
3	S3	RW	0	SSI Module 3 Sleep Mode Clock Gating Control Value Description 0 SSI module 3 is disabled in sleep mode. 1 Enable and provide a clock to SSI module 3 in sleep mode.
2	S2	RW	0	SSI Module 2 Sleep Mode Clock Gating Control Value Description 0 SSI module 2 is disabled in sleep mode. 1 Enable and provide a clock to SSI module 2 in sleep mode.
1	S1	RW	0	SSI Module 1 Sleep Mode Clock Gating Control Value Description 0 SSI module 1 is disabled in sleep mode. 1 Enable and provide a clock to SSI module 1 in sleep mode.
0	S0	RW	0	SSI Module 0 Sleep Mode Clock Gating Control Value Description 0 SSI module 0 is disabled in sleep mode. 1 Enable and provide a clock to SSI module 0 in sleep mode.

Register 114: Inter-Integrated Circuit Sleep Mode Clock Gating Control (SCGCI2C), offset 0x720

The **SCGCI2C** register provides software the capability to enable and disable the I²C modules in sleep mode. When enabled, a module is provided a clock. When disabled, the clock is disabled to save power.

Important: This register should be used to control the clocking for the I²C modules.

Inter-Integrated Circuit Sleep Mode Clock Gating Control (SCGCI2C)

Base 0x400F.E000
Offset 0x720
Type RW, reset 0x0000.0000

	31	30	29	28	27	26	25	24	23	22	21	20	19	18	17	16
	reserved															
Type	RO	RO	RO	RO	RO	RO	RO	RO	RO	RO	RO	RO	RO	RO	RO	RO
Reset	0	0	0	0	0	0	0	0	0	0	0	0	0	0	0	0
	15	14	13	12	11	10	9	8	7	6	5	4	3	2	1	0
	reserved						S9	S8	S7	S6	S5	S4	S3	S2	S1	S0
Type	RO	RO	RO	RO	RO	RO	RW	RW	RW	RW	RW	RW	RW	RW	RW	RW
Reset	0	0	0	0	0	0	0	0	0	0	0	0	0	0	0	0

Bit/Field	Name	Type	Reset	Description
31:10	reserved	RO	0	Software should not rely on the value of a reserved bit. To provide compatibility with future products, the value of a reserved bit should be preserved across a read-modify-write operation.
9	S9	RW	0	I ² C Module 9 Sleep Mode Clock Gating Control Value Description 0 I ² C module 9 is disabled in sleep mode. 1 Enable and provide a clock to I ² C module 9 in sleep mode.
8	S8	RW	0	I ² C Module 8 Sleep Mode Clock Gating Control Value Description 0 I ² C module 8 is disabled in sleep mode. 1 Enable and provide a clock to I ² C module 8 in sleep mode.
7	S7	RW	0	I ² C Module 7 Sleep Mode Clock Gating Control Value Description 0 I ² C module 7 is disabled in sleep mode. 1 Enable and provide a clock to I ² C module 7 in sleep mode.
6	S6	RW	0	I ² C Module 6 Sleep Mode Clock Gating Control Value Description 0 I ² C module 6 is disabled in sleep mode. 1 Enable and provide a clock to I ² C module 6 in sleep mode.

Bit/Field	Name	Type	Reset	Description
5	S5	RW	0	I ² C Module 5 Sleep Mode Clock Gating Control Value Description 0 I ² C module 5 is disabled in sleep mode. 1 Enable and provide a clock to I ² C module 5 in sleep mode.
4	S4	RW	0	I ² C Module 4 Sleep Mode Clock Gating Control Value Description 0 I ² C module 4 is disabled in sleep mode. 1 Enable and provide a clock to I ² C module 4 in sleep mode.
3	S3	RW	0	I ² C Module 3 Sleep Mode Clock Gating Control Value Description 0 I ² C module 3 is disabled in sleep mode. 1 Enable and provide a clock to I ² C module 3 in sleep mode.
2	S2	RW	0	I ² C Module 2 Sleep Mode Clock Gating Control Value Description 0 I ² C module 2 is disabled in sleep mode. 1 Enable and provide a clock to I ² C module 2 in sleep mode.
1	S1	RW	0	I ² C Module 1 Sleep Mode Clock Gating Control Value Description 0 I ² C module 1 is disabled in sleep mode. 1 Enable and provide a clock to I ² C module 1 in sleep mode.
0	S0	RW	0	I ² C Module 0 Sleep Mode Clock Gating Control Value Description 0 I ² C module 0 is disabled. 1 Enable and provide a clock to I ² C module 0 in sleep mode.

Register 115: Universal Serial Bus Sleep Mode Clock Gating Control (SCGCUSB), offset 0x728

The **SCGCUSB** register provides software the capability to enable and disable the USB module in sleep mode. When enabled, a module is provided a clock. When disabled, the clock is disabled to save power.

Important: This register should be used to control the clocking for the USB module.

Universal Serial Bus Sleep Mode Clock Gating Control (SCGCUSB)

Base 0x400F.E000
 Offset 0x728
 Type RW, reset 0x0000.0000

	31	30	29	28	27	26	25	24	23	22	21	20	19	18	17	16
	reserved															
Type	RO	RO	RO	RO	RO	RO	RO	RO	RO	RO	RO	RO	RO	RO	RO	RO
Reset	0	0	0	0	0	0	0	0	0	0	0	0	0	0	0	0
	15	14	13	12	11	10	9	8	7	6	5	4	3	2	1	0
	reserved															
Type	RO	RO	RO	RO	RO	RO	RO	RO	RO	RO	RO	RO	RO	RO	RO	RW
Reset	0	0	0	0	0	0	0	0	0	0	0	0	0	0	0	0

Bit/Field	Name	Type	Reset	Description
31:1	reserved	RO	0	Software should not rely on the value of a reserved bit. To provide compatibility with future products, the value of a reserved bit should be preserved across a read-modify-write operation.
0	S0	RW	0	USB Module Sleep Mode Clock Gating Control
				Value Description
				0 USB module is disabled in sleep mode.
				1 Enable and provide a clock to the USB module in sleep mode.

Register 116: Ethernet PHY Sleep Mode Clock Gating Control (SCGCEPHY), offset 0x730

The **SCGCEPHY** register provides software the capability to enable and disable the PHY module in sleep mode. When enabled, a module is provided a clock. When disabled, the clock is disabled to save power.

Important: This register should be used to control the clocking for the PHY module.

Ethernet PHY Sleep Mode Clock Gating Control (SCGCEPHY)

Base 0x400F.E000

Offset 0x730

Type RW, reset 0x0000.0000

	31	30	29	28	27	26	25	24	23	22	21	20	19	18	17	16
	reserved															
Type	RO	RO	RO	RO	RO	RO	RO	RO	RO	RO	RO	RO	RO	RO	RO	RO
Reset	0	0	0	0	0	0	0	0	0	0	0	0	0	0	0	0
	15	14	13	12	11	10	9	8	7	6	5	4	3	2	1	0
	reserved															
Type	RO	RO	RO	RO	RO	RO	RO	RO	RO	RO	RO	RO	RO	RO	RO	RW
Reset	0	0	0	0	0	0	0	0	0	0	0	0	0	0	0	0

Bit/Field	Name	Type	Reset	Description
31:1	reserved	RO	0	Software should not rely on the value of a reserved bit. To provide compatibility with future products, the value of a reserved bit should be preserved across a read-modify-write operation.
0	S0	RW	0	PHY Module Sleep Mode Clock Gating Control
				Value Description
				0 PHY module is disabled in sleep mode.
				1 Enable and provide a clock to the PHY module in sleep mode.

Register 117: Controller Area Network Sleep Mode Clock Gating Control (SCGCCAN), offset 0x734

The **SCGCCAN** register provides software the capability to enable and disable the CAN modules in sleep mode. When enabled, a module is provided a clock. When disabled, the clock is disabled to save power.

Important: This register should be used to control the clocking for the CAN modules.

Controller Area Network Sleep Mode Clock Gating Control (SCGCCAN)

Base 0x400F.E000
 Offset 0x734
 Type RW, reset 0x0000.0000

	31	30	29	28	27	26	25	24	23	22	21	20	19	18	17	16	
	reserved																
Type	RO	RO	RO	RO	RO	RO	RO	RO	RO	RO	RO	RO	RO	RO	RO	RO	
Reset	0	0	0	0	0	0	0	0	0	0	0	0	0	0	0	0	
	15	14	13	12	11	10	9	8	7	6	5	4	3	2	1	0	
	reserved															S1	S0
Type	RO	RO	RO	RO	RO	RO	RO	RO	RO	RO	RO	RO	RO	RO	RO	RW	RW
Reset	0	0	0	0	0	0	0	0	0	0	0	0	0	0	0	0	0

Bit/Field	Name	Type	Reset	Description
31:2	reserved	RO	0	Software should not rely on the value of a reserved bit. To provide compatibility with future products, the value of a reserved bit should be preserved across a read-modify-write operation.
1	S1	RW	0	CAN Module 1 Sleep Mode Clock Gating Control Value Description 0 CAN module 1 is disabled in sleep mode. 1 Enable and provide a clock to CAN module 1 in sleep mode.
0	S0	RW	0	CAN Module 0 Sleep Mode Clock Gating Control Value Description 0 CAN module 0 is disabled. 1 Enable and provide a clock to CAN module 0 in sleep mode.

Register 118: Analog-to-Digital Converter Sleep Mode Clock Gating Control (SCGCADC), offset 0x738

The **SCGCADC** register provides software the capability to enable and disable the ADC modules in sleep mode. When enabled, a module is provided a clock. When disabled, the clock is disabled to save power.

Important: This register should be used to control the clocking for the ADC modules.

Analog-to-Digital Converter Sleep Mode Clock Gating Control (SCGCADC)

Base 0x400F.E000

Offset 0x738

Type RW, reset 0x0000.0000

	31	30	29	28	27	26	25	24	23	22	21	20	19	18	17	16	
	reserved																
Type	RO	RO	RO	RO	RO	RO	RO	RO	RO	RO	RO	RO	RO	RO	RO	RO	
Reset	0	0	0	0	0	0	0	0	0	0	0	0	0	0	0	0	
	15	14	13	12	11	10	9	8	7	6	5	4	3	2	1	0	
	reserved															S1	S0
Type	RO	RO	RO	RO	RO	RO	RO	RO	RO	RO	RO	RO	RO	RO	RO	RW	RW
Reset	0	0	0	0	0	0	0	0	0	0	0	0	0	0	0	0	0

Bit/Field	Name	Type	Reset	Description
31:2	reserved	RO	0	Software should not rely on the value of a reserved bit. To provide compatibility with future products, the value of a reserved bit should be preserved across a read-modify-write operation.
1	S1	RW	0	ADC Module 1 Sleep Mode Clock Gating Control Value Description 0 ADC module 1 is disabled in sleep mode. 1 Enable and provide a clock to ADC module 1 in sleep mode.
0	S0	RW	0	ADC Module 0 Sleep Mode Clock Gating Control Value Description 0 ADC module 0 is disabled in sleep mode. 1 Enable and provide a clock to ADC module 0 in sleep mode.

Register 119: Analog Comparator Sleep Mode Clock Gating Control (SCGCACMP), offset 0x73C

The **SCGCACMP** register provides software the capability to enable and disable the analog comparator module in sleep mode. When enabled, a module is provided a clock. When disabled, the clock is disabled to save power.

Important: This register should be used to control the clocking for the analog comparator module.

Analog Comparator Sleep Mode Clock Gating Control (SCGCACMP)

Base 0x400F.E000
 Offset 0x73C
 Type RW, reset 0x0000.0000

	31	30	29	28	27	26	25	24	23	22	21	20	19	18	17	16
	reserved															
Type	RO	RO	RO	RO	RO	RO	RO	RO	RO	RO	RO	RO	RO	RO	RO	RO
Reset	0	0	0	0	0	0	0	0	0	0	0	0	0	0	0	0
	15	14	13	12	11	10	9	8	7	6	5	4	3	2	1	0
	reserved															S0
Type	RO	RO	RO	RO	RO	RO	RO	RO	RO	RO	RO	RO	RO	RO	RO	RW
Reset	0	0	0	0	0	0	0	0	0	0	0	0	0	0	0	0

Bit/Field	Name	Type	Reset	Description
31:1	reserved	RO	0	Software should not rely on the value of a reserved bit. To provide compatibility with future products, the value of a reserved bit should be preserved across a read-modify-write operation.
0	S0	RW	0	Analog Comparator Module 0 Sleep Mode Clock Gating Control
				Value Description
				0 Analog comparator module is disabled in sleep mode.
				1 Enable and provide a clock to the analog comparator module in sleep mode.

Register 120: Pulse Width Modulator Sleep Mode Clock Gating Control (SCGCPWM), offset 0x740

The **SCGCPWM** register provides software the capability to enable and disable the PWM modules in sleep mode. When enabled, a module is provided a clock. When disabled, the clock is disabled to save power.

Important: This register should be used to control the clocking for the PWM modules.

Pulse Width Modulator Sleep Mode Clock Gating Control (SCGCPWM)

Base 0x400F.E000

Offset 0x740

Type RW, reset 0x0000.0000

	31	30	29	28	27	26	25	24	23	22	21	20	19	18	17	16
	reserved															
Type	RO	RO	RO	RO	RO	RO	RO	RO	RO	RO	RO	RO	RO	RO	RO	RO
Reset	0	0	0	0	0	0	0	0	0	0	0	0	0	0	0	0
	15	14	13	12	11	10	9	8	7	6	5	4	3	2	1	0
	reserved															
																S0
Type	RO	RO	RO	RO	RO	RO	RO	RO	RO	RO	RO	RO	RO	RO	RO	RW
Reset	0	0	0	0	0	0	0	0	0	0	0	0	0	0	0	0

Bit/Field	Name	Type	Reset	Description
31:1	reserved	RO	0	Software should not rely on the value of a reserved bit. To provide compatibility with future products, the value of a reserved bit should be preserved across a read-modify-write operation.
0	S0	RW	0	PWM Module 0 Sleep Mode Clock Gating Control
				Value Description
			0	PWM module 0 is disabled in sleep mode.
			1	Enable and provide a clock to PWM module 0 in sleep mode.

Register 121: Quadrature Encoder Interface Sleep Mode Clock Gating Control (SCGCQEI), offset 0x744

The **SCGCQEI** register provides software the capability to enable and disable the QEI modules in sleep mode. When enabled, a module is provided a clock. When disabled, the clock is disabled to save power.

Important: This register should be used to control the clocking for the QEI modules.

Quadrature Encoder Interface Sleep Mode Clock Gating Control (SCGCQEI)

Base 0x400F.E000
 Offset 0x744
 Type RW, reset 0x0000.0000

	31	30	29	28	27	26	25	24	23	22	21	20	19	18	17	16
	reserved															
Type	RO	RO	RO	RO	RO	RO	RO	RO	RO	RO	RO	RO	RO	RO	RO	RO
Reset	0	0	0	0	0	0	0	0	0	0	0	0	0	0	0	0
	15	14	13	12	11	10	9	8	7	6	5	4	3	2	1	0
	reserved															S0
Type	RO	RO	RO	RO	RO	RO	RO	RO	RO	RO	RO	RO	RO	RO	RO	RW
Reset	0	0	0	0	0	0	0	0	0	0	0	0	0	0	0	0

Bit/Field	Name	Type	Reset	Description
31:1	reserved	RO	0	Software should not rely on the value of a reserved bit. To provide compatibility with future products, the value of a reserved bit should be preserved across a read-modify-write operation.
0	S0	RW	0	QEI Module 0 Sleep Mode Clock Gating Control
				Value Description
				0 QEI module 0 is disabled in sleep mode.
				1 Enable and provide a clock to QEI module 0 in sleep mode.

Register 122: EEPROM Sleep Mode Clock Gating Control (SCGCEEPROM), offset 0x758

The **SCGCEEPROM** register provides software the capability to enable and disable the EEPROM module in sleep mode. When enabled, a module is provided a clock. When disabled, the clock is disabled to save power.

EEPROM Sleep Mode Clock Gating Control (SCGCEEPROM)

Base 0x400F.E000
Offset 0x758
Type RW, reset 0x0000.0000

	31	30	29	28	27	26	25	24	23	22	21	20	19	18	17	16
	reserved															
Type	RO	RO	RO	RO	RO	RO	RO	RO	RO	RO	RO	RO	RO	RO	RO	RO
Reset	0	0	0	0	0	0	0	0	0	0	0	0	0	0	0	0
	15	14	13	12	11	10	9	8	7	6	5	4	3	2	1	0
	reserved															S0
Type	RO	RO	RO	RO	RO	RO	RO	RO	RO	RO	RO	RO	RO	RO	RO	RW
Reset	0	0	0	0	0	0	0	0	0	0	0	0	0	0	0	0

Bit/Field	Name	Type	Reset	Description
31:1	reserved	RO	0	Software should not rely on the value of a reserved bit. To provide compatibility with future products, the value of a reserved bit should be preserved across a read-modify-write operation.
0	S0	RW	0	EEPROM Module 0 Sleep Mode Clock Gating Control
				Value Description
				0 EEPROM module is disabled.
				1 Enable and provide a clock to the EEPROM module in sleep mode.

Register 123: CRC and Cryptographic Modules Sleep Mode Clock Gating Control (SCGCCM), offset 0x774

The **SCGCCM** register provides software the capability to enable and disable the CRC and Encryption Control, AES, DES, and SHA/MD5 modules in sleep mode. When enabled, the modules are provided a clock . When disabled, the clock is disabled to save power.

Important: This register should be used to control the clocking for the CRC, AES, DES, and SHA/MD5 modules.

CRC and Cryptographic Modules Sleep Mode Clock Gating Control (SCGCCM)

Base 0x400F.E000
 Offset 0x774
 Type RW, reset 0x0000.0000

	31	30	29	28	27	26	25	24	23	22	21	20	19	18	17	16
	reserved															
Type	RO	RO	RO	RO	RO	RO	RO	RO	RO	RO	RO	RO	RO	RO	RO	RO
Reset	0	0	0	0	0	0	0	0	0	0	0	0	0	0	0	0
	15	14	13	12	11	10	9	8	7	6	5	4	3	2	1	0
	reserved															S0
Type	RO	RO	RO	RO	RO	RO	RO	RO	RO	RO	RO	RO	RO	RO	RO	RW
Reset	0	0	0	0	0	0	0	0	0	0	0	0	0	0	0	0

Bit/Field	Name	Type	Reset	Description	
31:1	reserved	RO	0	Software should not rely on the value of a reserved bit. To provide compatibility with future products, the value of a reserved bit should be preserved across a read-modify-write operation.	
0	S0	RW	0	CRC and Cryptographic Modules Sleep Mode Clock Gating Control	
Value Description					
	0	The CRC, AES, DES, and SHA/MD5 modules are disabled in sleep mode.			
	1	Enable and provide a clock to the CRC, AES, DES, and SHA/MD5 modules in sleep mode.			

Register 124: Ethernet MAC Sleep Mode Clock Gating Control (SCGCEMAC), offset 0x79C

The **SCGCEMAC** register provides software the capability to enable and disable the Ethernet MAC module in sleep mode. When enabled, a module is provided a clock. When disabled, the clock is disabled to save power.

Important: This register should be used to control the clocking for the Ethernet MAC module.

Ethernet MAC Sleep Mode Clock Gating Control (SCGCEMAC)

Base 0x400F.E000

Offset 0x79C

Type RW, reset 0x0000.0000

	31	30	29	28	27	26	25	24	23	22	21	20	19	18	17	16
	reserved															
Type	RO	RO	RO	RO	RO	RO	RO	RO	RO	RO	RO	RO	RO	RO	RO	RO
Reset	0	0	0	0	0	0	0	0	0	0	0	0	0	0	0	0
	15	14	13	12	11	10	9	8	7	6	5	4	3	2	1	0
	reserved															
																S0
Type	RO	RO	RO	RO	RO	RO	RO	RO	RO	RO	RO	RO	RO	RO	RO	RW
Reset	0	0	0	0	0	0	0	0	0	0	0	0	0	0	0	0

Bit/Field	Name	Type	Reset	Description
31:1	reserved	RO	0	Software should not rely on the value of a reserved bit. To provide compatibility with future products, the value of a reserved bit should be preserved across a read-modify-write operation.
0	S0	RW	0	Ethernet MAC Module 0 Sleep Mode Clock Gating Control
				Value Description
				0 Ethernet MAC module 0 is disabled in sleep mode.
				1 Enable and provide a clock to Ethernet MAC module 0 in sleep mode.

Register 125: Watchdog Timer Deep-Sleep Mode Clock Gating Control (DCGCWD), offset 0x800

The **DCGCWD** register provides software the capability to enable and disable watchdog modules in deep-sleep mode. When enabled, a module is provided a clock. When disabled, the clock is disabled to save power.

Important: This register should be used to control the clocking for the watchdog modules.

Watchdog Timer Deep-Sleep Mode Clock Gating Control (DCGCWD)

Base 0x400F.E000
 Offset 0x800
 Type RW, reset 0x0000.0000

	31	30	29	28	27	26	25	24	23	22	21	20	19	18	17	16	
	reserved																
Type	RO	RO	RO	RO	RO	RO	RO	RO	RO	RO	RO	RO	RO	RO	RO	RO	
Reset	0	0	0	0	0	0	0	0	0	0	0	0	0	0	0	0	
	15	14	13	12	11	10	9	8	7	6	5	4	3	2	1	0	
	reserved															D1	D0
Type	RO	RO	RO	RO	RO	RO	RO	RO	RO	RO	RO	RO	RO	RO	RO	RW	RW
Reset	0	0	0	0	0	0	0	0	0	0	0	0	0	0	0	0	0

Bit/Field	Name	Type	Reset	Description
31:2	reserved	RO	0	Software should not rely on the value of a reserved bit. To provide compatibility with future products, the value of a reserved bit should be preserved across a read-modify-write operation.
1	D1	RW	0	Watchdog Timer 1 Deep-Sleep Mode Clock Gating Control Value Description 0 Watchdog module 1 is disabled in deep-sleep mode. 1 Enable and provide a clock to Watchdog module 1 in deep-sleep mode.
0	D0	RW	0	Watchdog Timer 0 Deep-Sleep Mode Clock Gating Control Value Description 0 Watchdog module 0 is disabled in deep-sleep mode. 1 Enable and provide a clock to Watchdog module 0 in deep-sleep mode.

Register 126: 16/32-Bit General-Purpose Timer Deep-Sleep Mode Clock Gating Control (DCGCTIMER), offset 0x804

The **DCGCGPT32** register provides software the capability to enable and disable 16/32-bit timer modules in deep-sleep mode. When enabled, a module is provided a clock. When disabled, the clock is disabled to save power.

Important: This register should be used to control the clocking for the timer modules.

16/32-Bit General-Purpose Timer Deep-Sleep Mode Clock Gating Control (DCGCTIMER)

Base 0x400F.E000

Offset 0x804

Type RW, reset 0x0000.0000

	31	30	29	28	27	26	25	24	23	22	21	20	19	18	17	16
	reserved															
Type	RO	RO	RO	RO	RO	RO	RO	RO	RO	RO	RO	RO	RO	RO	RO	RO
Reset	0	0	0	0	0	0	0	0	0	0	0	0	0	0	0	0
	15	14	13	12	11	10	9	8	7	6	5	4	3	2	1	0
	reserved								D7	D6	D5	D4	D3	D2	D1	D0
Type	RO	RO	RO	RO	RO	RO	RO	RO	RW	RW	RW	RW	RW	RW	RW	RW
Reset	0	0	0	0	0	0	0	0	0	0	0	0	0	0	0	0

Bit/Field	Name	Type	Reset	Description
31:8	reserved	RO	0	Software should not rely on the value of a reserved bit. To provide compatibility with future products, the value of a reserved bit should be preserved across a read-modify-write operation.
7	D7	RW	0	16/32-Bit General-Purpose Timer 7 Deep-Sleep Mode Clock Gating Control Value Description 0 16/32-bit general-purpose timer module 7 is disabled in deep-sleep mode. 1 Enable and provide a clock to 16/32-bit general-purpose timer module 7 in deep-sleep mode.
6	D6	RW	0	16/32-Bit General-Purpose Timer 6 Deep-Sleep Mode Clock Gating Control Value Description 0 16/32-bit general-purpose timer module 6 is disabled in deep-sleep mode. 1 Enable and provide a clock to 16/32-bit general-purpose timer module 6 in deep-sleep mode.
5	D5	RW	0	16/32-Bit General-Purpose Timer 5 Deep-Sleep Mode Clock Gating Control Value Description 0 16/32-bit general-purpose timer module 5 is disabled in deep-sleep mode. 1 Enable and provide a clock to 16/32-bit general-purpose timer module 5 in deep-sleep mode.

Bit/Field	Name	Type	Reset	Description
4	D4	RW	0	<p>16/32-Bit General-Purpose Timer 4 Deep-Sleep Mode Clock Gating Control</p> <p>Value Description</p> <p>0 16/32-bit general-purpose timer module 4 is disabled in deep-sleep mode.</p> <p>1 Enable and provide a clock to 16/32-bit general-purpose timer module 4 in deep-sleep mode.</p>
3	D3	RW	0	<p>16/32-Bit General-Purpose Timer 3 Deep-Sleep Mode Clock Gating Control</p> <p>Value Description</p> <p>0 16/32-bit general-purpose timer module 3 is disabled in deep-sleep mode.</p> <p>1 Enable and provide a clock to 16/32-bit general-purpose timer module 3 in deep-sleep mode.</p>
2	D2	RW	0	<p>16/32-Bit General-Purpose Timer 2 Deep-Sleep Mode Clock Gating Control</p> <p>Value Description</p> <p>0 16/32-bit general-purpose timer module 2 is disabled in deep-sleep mode.</p> <p>1 Enable and provide a clock to 16/32-bit general-purpose timer module 2 in deep-sleep mode.</p>
1	D1	RW	0	<p>16/32-Bit General-Purpose Timer 1 Deep-Sleep Mode Clock Gating Control</p> <p>Value Description</p> <p>0 16/32-bit general-purpose timer module 1 is disabled in deep-sleep mode.</p> <p>1 Enable and provide a clock to 16/32-bit general-purpose timer module 1 in deep-sleep mode.</p>
0	D0	RW	0	<p>16/32-Bit General-Purpose Timer 0 Deep-Sleep Mode Clock Gating Control</p> <p>Value Description</p> <p>0 16/32-bit general-purpose timer module 0 is disabled in deep-sleep mode.</p> <p>1 Enable and provide a clock to 16/32-bit general-purpose timer module 0 in deep-sleep mode.</p>

Register 127: General-Purpose Input/Output Deep-Sleep Mode Clock Gating Control (DCGCGPIO), offset 0x808

The **DCGCGPIO** register provides software the capability to enable and disable GPIO modules in deep-sleep mode. When enabled, a module is provided a clock. When disabled, the clock is disabled to save power.

Important: This register should be used to control the clocking for the GPIO modules.

General-Purpose Input/Output Deep-Sleep Mode Clock Gating Control (DCGCGPIO)

Base 0x400F.E000
Offset 0x808
Type RW, reset 0x0000.0000

	31	30	29	28	27	26	25	24	23	22	21	20	19	18	17	16
	reserved															
Type	RO	RO	RO	RO	RO	RO	RO	RO	RO	RO	RO	RO	RO	RO	RO	RO
Reset	0	0	0	0	0	0	0	0	0	0	0	0	0	0	0	0
	15	14	13	12	11	10	9	8	7	6	5	4	3	2	1	0
	reserved	D14	D13	D12	D11	D10	D9	D8	D7	D6	D5	D4	D3	D2	D1	D0
Type	RO	RW	RW	RW	RW	RW	RW	RW	RW	RW	RW	RW	RW	RW	RW	RW
Reset	0	0	0	0	0	0	0	0	0	0	0	0	0	0	0	0

Bit/Field	Name	Type	Reset	Description
31:15	reserved	RO	0	Software should not rely on the value of a reserved bit. To provide compatibility with future products, the value of a reserved bit should be preserved across a read-modify-write operation.
14	D14	RW	0	GPIO Port Q Deep-Sleep Mode Clock Gating Control Value Description 0 GPIO Port Q is disabled in deep-sleep mode. 1 Enable and provide a clock to GPIO Port Q in deep-sleep mode.
13	D13	RW	0	GPIO Port P Deep-Sleep Mode Clock Gating Control Value Description 0 GPIO Port P is disabled in deep-sleep mode. 1 Enable and provide a clock to GPIO Port P in deep-sleep mode.
12	D12	RW	0	GPIO Port N Deep-Sleep Mode Clock Gating Control Value Description 0 GPIO Port N is disabled in deep-sleep mode. 1 Enable and provide a clock to GPIO Port N in deep-sleep mode.
11	D11	RW	0	GPIO Port M Deep-Sleep Mode Clock Gating Control Value Description 0 GPIO Port M is disabled in deep-sleep mode. 1 Enable and provide a clock to GPIO Port M in deep-sleep mode.

Bit/Field	Name	Type	Reset	Description
10	D10	RW	0	GPIO Port L Deep-Sleep Mode Clock Gating Control Value Description 0 GPIO Port L is disabled in deep-sleep mode. 1 Enable and provide a clock to GPIO Port L in deep-sleep mode.
9	D9	RW	0	GPIO Port K Deep-Sleep Mode Clock Gating Control Value Description 0 GPIO Port K is disabled in deep-sleep mode. 1 Enable and provide a clock to GPIO Port K in deep-sleep mode.
8	D8	RW	0	GPIO Port J Deep-Sleep Mode Clock Gating Control Value Description 0 GPIO Port J is disabled in deep-sleep mode. 1 Enable and provide a clock to GPIO Port J in deep-sleep mode.
7	D7	RW	0	GPIO Port H Deep-Sleep Mode Clock Gating Control Value Description 0 GPIO Port H is disabled in deep-sleep mode. 1 Enable and provide a clock to GPIO Port H in deep-sleep mode.
6	D6	RW	0	GPIO Port G Deep-Sleep Mode Clock Gating Control Value Description 0 GPIO Port G is disabled in deep-sleep mode. 1 Enable and provide a clock to GPIO Port G in deep-sleep mode.
5	D5	RW	0	GPIO Port F Deep-Sleep Mode Clock Gating Control Value Description 0 GPIO Port F is disabled in deep-sleep mode. 1 Enable and provide a clock to GPIO Port F in deep-sleep mode.
4	D4	RW	0	GPIO Port E Deep-Sleep Mode Clock Gating Control Value Description 0 GPIO Port E is disabled in deep-sleep mode. 1 Enable and provide a clock to GPIO Port E in deep-sleep mode.

Bit/Field	Name	Type	Reset	Description
3	D3	RW	0	GPIO Port D Deep-Sleep Mode Clock Gating Control Value Description 0 GPIO Port D is disabled in deep-sleep mode. 1 Enable and provide a clock to GPIO Port D in deep-sleep mode.
2	D2	RW	0	GPIO Port C Deep-Sleep Mode Clock Gating Control Value Description 0 GPIO Port C is disabled in deep-sleep mode. 1 Enable and provide a clock to GPIO Port C in deep-sleep mode.
1	D1	RW	0	GPIO Port B Deep-Sleep Mode Clock Gating Control Value Description 0 GPIO Port B is disabled in deep-sleep mode. 1 Enable and provide a clock to GPIO Port B in deep-sleep mode.
0	D0	RW	0	GPIO Port A Deep-Sleep Mode Clock Gating Control Value Description 0 GPIO Port A is disabled in deep-sleep mode. 1 Enable and provide a clock to GPIO Port A in deep-sleep mode.

Register 128: Micro Direct Memory Access Deep-Sleep Mode Clock Gating Control (DCGCDMA), offset 0x80C

The **DCGCDMA** register provides software the capability to enable and disable the μ DMA module in deep-sleep mode. When enabled, a module is provided a clock. When disabled, the clock is disabled to save power.

Important: This register should be used to control the clocking for the μ DMA module.

Micro Direct Memory Access Deep-Sleep Mode Clock Gating Control (DCGCDMA)

Base 0x400F.E000
 Offset 0x80C
 Type RW, reset 0x0000.0000

	31	30	29	28	27	26	25	24	23	22	21	20	19	18	17	16
	reserved															
Type	RO	RO	RO	RO	RO	RO	RO	RO	RO	RO	RO	RO	RO	RO	RO	RO
Reset	0	0	0	0	0	0	0	0	0	0	0	0	0	0	0	0
	15	14	13	12	11	10	9	8	7	6	5	4	3	2	1	0
	reserved															D0
Type	RO	RO	RO	RO	RO	RO	RO	RO	RO	RO	RO	RO	RO	RO	RO	RW
Reset	0	0	0	0	0	0	0	0	0	0	0	0	0	0	0	0

Bit/Field	Name	Type	Reset	Description
31:1	reserved	RO	0	Software should not rely on the value of a reserved bit. To provide compatibility with future products, the value of a reserved bit should be preserved across a read-modify-write operation.
0	D0	RW	0	μ DMA Module Deep-Sleep Mode Clock Gating Control
				Value Description
				0 μ DMA module is disabled in deep-sleep mode.
				1 Enable and provide a clock to the μ DMA module in deep-sleep mode.

Register 129: EPI Deep-Sleep Mode Clock Gating Control (DCGCEPI), offset 0x810

The **DCGCEPI** register provides software the capability to enable and disable the EPI module in deep-sleep mode. When enabled, a module is provided a clock. When disabled, the clock is disabled to save power.

Important: This register should be used to control the clocking for the EPI module.

EPI Deep-Sleep Mode Clock Gating Control (DCGCEPI)

Base 0x400F.E000

Offset 0x810

Type RW, reset 0x0000.0000

	31	30	29	28	27	26	25	24	23	22	21	20	19	18	17	16
	reserved															
Type	RO	RO	RO	RO	RO	RO	RO	RO	RO	RO	RO	RO	RO	RO	RO	RO
Reset	0	0	0	0	0	0	0	0	0	0	0	0	0	0	0	0
	15	14	13	12	11	10	9	8	7	6	5	4	3	2	1	0
	reserved															
Type	RO	RO	RO	RO	RO	RO	RO	RO	RO	RO	RO	RO	RO	RO	RO	RW
Reset	0	0	0	0	0	0	0	0	0	0	0	0	0	0	0	0

Bit/Field	Name	Type	Reset	Description	
31:1	reserved	RO	0	Software should not rely on the value of a reserved bit. To provide compatibility with future products, the value of a reserved bit should be preserved across a read-modify-write operation.	
0	D0	RW	0	EPI Module Deep-Sleep Mode Clock Gating Control	
Value Description					
	0	EPI module is disabled in deep-sleep mode.			
	1	Enable and provide a clock to the EPI module in deep-sleep mode.			

Register 130: Hibernation Deep-Sleep Mode Clock Gating Control (DCGCHIB), offset 0x814

The **DCGCHIB** register provides software the capability to enable and disable the Hibernation module in deep-sleep mode. When enabled, a module is provided a clock. When disabled, the clock is disabled to save power.

Important: This register should be used to control the clocking for the Hibernation module.

Hibernation Deep-Sleep Mode Clock Gating Control (DCGCHIB)

Base 0x400F.E000
 Offset 0x814
 Type RW, reset 0x0000.0001

	31	30	29	28	27	26	25	24	23	22	21	20	19	18	17	16
	reserved															
Type	RO	RO	RO	RO	RO	RO	RO	RO	RO	RO	RO	RO	RO	RO	RO	RO
Reset	0	0	0	0	0	0	0	0	0	0	0	0	0	0	0	0
	15	14	13	12	11	10	9	8	7	6	5	4	3	2	1	0
	reserved															
	D0															
Type	RO	RO	RO	RO	RO	RO	RO	RO	RO	RO	RO	RO	RO	RO	RO	RW
Reset	0	0	0	0	0	0	0	0	0	0	0	0	0	0	0	1

Bit/Field	Name	Type	Reset	Description
31:1	reserved	RO	0	Software should not rely on the value of a reserved bit. To provide compatibility with future products, the value of a reserved bit should be preserved across a read-modify-write operation.
0	D0	RW	1	Hibernation Module Deep-Sleep Mode Clock Gating Control

Value	Description
0	Hibernation module is disabled in deep-sleep mode.
1	Enable and provide a clock to the Hibernation module in deep-sleep mode.

Register 131: Universal Asynchronous Receiver/Transmitter Deep-Sleep Mode Clock Gating Control (DCGCUART), offset 0x818

The **DCGCUART** register provides software the capability to enable and disable the UART modules in deep-sleep mode. When enabled, a module is provided a clock. When disabled, the clock is disabled to save power.

Important: This register should be used to control the clocking for the UART modules.

Universal Asynchronous Receiver/Transmitter Deep-Sleep Mode Clock Gating Control (DCGCUART)

Base 0x400F.E000
Offset 0x818
Type RW, reset 0x0000.0000

	31	30	29	28	27	26	25	24	23	22	21	20	19	18	17	16
	reserved															
Type	RO	RO	RO	RO	RO	RO	RO	RO	RO	RO	RO	RO	RO	RO	RO	RO
Reset	0	0	0	0	0	0	0	0	0	0	0	0	0	0	0	0
	15	14	13	12	11	10	9	8	7	6	5	4	3	2	1	0
	reserved								D7	D6	D5	D4	D3	D2	D1	D0
Type	RO	RO	RO	RO	RO	RO	RO	RO	RW	RW	RW	RW	RW	RW	RW	RW
Reset	0	0	0	0	0	0	0	0	0	0	0	0	0	0	0	0

Bit/Field	Name	Type	Reset	Description
31:8	reserved	RO	0	Software should not rely on the value of a reserved bit. To provide compatibility with future products, the value of a reserved bit should be preserved across a read-modify-write operation.
7	D7	RW	0	UART Module 7 Deep-Sleep Mode Clock Gating Control Value Description 0 UART module 7 is disabled in deep-sleep mode. 1 Enable and provide a clock to UART module 7 in deep-sleep mode.
6	D6	RW	0	UART Module 6 Deep-Sleep Mode Clock Gating Control Value Description 0 UART module 6 is disabled in deep-sleep mode. 1 Enable and provide a clock to UART module 6 in deep-sleep mode.
5	D5	RW	0	UART Module 5 Deep-Sleep Mode Clock Gating Control Value Description 0 UART module 5 is disabled in deep-sleep mode. 1 Enable and provide a clock to UART module 5 in deep-sleep mode.

Bit/Field	Name	Type	Reset	Description
4	D4	RW	0	UART Module 4 Deep-Sleep Mode Clock Gating Control Value Description 0 UART module 4 is disabled in deep-sleep mode. 1 Enable and provide a clock to UART module 4 in deep-sleep mode.
3	D3	RW	0	UART Module 3 Deep-Sleep Mode Clock Gating Control Value Description 0 UART module 3 is disabled in deep-sleep mode. 1 Enable and provide a clock to UART module 3 in deep-sleep mode.
2	D2	RW	0	UART Module 2 Deep-Sleep Mode Clock Gating Control Value Description 0 UART module 2 is disabled in deep-sleep mode. 1 Enable and provide a clock to UART module 2 in deep-sleep mode.
1	D1	RW	0	UART Module 1 Deep-Sleep Mode Clock Gating Control Value Description 0 UART module 1 is disabled in deep-sleep mode. 1 Enable and provide a clock to UART module 1 in deep-sleep mode.
0	D0	RW	0	UART Module 0 Deep-Sleep Mode Clock Gating Control Value Description 0 UART module 0 is disabled in deep-sleep mode. 1 Enable and provide a clock to UART module 0 in deep-sleep mode.

Register 132: Synchronous Serial Interface Deep-Sleep Mode Clock Gating Control (DCGCSSI), offset 0x81C

The **DCGCSSI** register provides software the capability to enable and disable the SSI modules in deep-sleep mode. When enabled, a module is provided a clock. When disabled, the clock is disabled to save power.

Important: This register should be used to control the clocking for the SSI modules.

Synchronous Serial Interface Deep-Sleep Mode Clock Gating Control (DCGCSSI)

Base 0x400F.E000
Offset 0x81C
Type RW, reset 0x0000.0000

	31	30	29	28	27	26	25	24	23	22	21	20	19	18	17	16
	reserved															
Type	RO	RO	RO	RO	RO	RO	RO	RO	RO	RO	RO	RO	RO	RO	RO	RO
Reset	0	0	0	0	0	0	0	0	0	0	0	0	0	0	0	0
	15	14	13	12	11	10	9	8	7	6	5	4	3	2	1	0
	reserved												D3	D2	D1	D0
Type	RO	RO	RO	RO	RO	RO	RO	RO	RO	RO	RO	RO	RW	RW	RW	RW
Reset	0	0	0	0	0	0	0	0	0	0	0	0	0	0	0	0

Bit/Field	Name	Type	Reset	Description
31:4	reserved	RO	0	Software should not rely on the value of a reserved bit. To provide compatibility with future products, the value of a reserved bit should be preserved across a read-modify-write operation.
3	D3	RW	0	SSI Module 3 Deep-Sleep Mode Clock Gating Control Value Description 0 SSI module 3 is disabled in deep-sleep mode. 1 Enable and provide a clock to SSI module 3 in deep-sleep mode.
2	D2	RW	0	SSI Module 2 Deep-Sleep Mode Clock Gating Control Value Description 0 SSI module 2 is disabled in deep-sleep mode. 1 Enable and provide a clock to SSI module 2 in deep-sleep mode.
1	D1	RW	0	SSI Module 1 Deep-Sleep Mode Clock Gating Control Value Description 0 SSI module 1 is disabled in deep-sleep mode. 1 Enable and provide a clock to SSI module 1 in deep-sleep mode.
0	D0	RW	0	SSI Module 0 Deep-Sleep Mode Clock Gating Control Value Description 0 SSI module 0 is disabled in deep-sleep mode. 1 Enable and provide a clock to SSI module 0 in deep-sleep mode.

Register 133: Inter-Integrated Circuit Deep-Sleep Mode Clock Gating Control (DCGCI2C), offset 0x820

The **DCGCI2C** register provides software the capability to enable and disable the I²C modules in deep-sleep mode. When enabled, a module is provided a clock. When disabled, the clock is disabled to save power.

Important: This register should be used to control the clocking for the I²C modules.

Inter-Integrated Circuit Deep-Sleep Mode Clock Gating Control (DCGCI2C)

Base 0x400F.E000
Offset 0x820
Type RW, reset 0x0000.0000

	31	30	29	28	27	26	25	24	23	22	21	20	19	18	17	16
	reserved															
Type	RO	RO	RO	RO	RO	RO	RO	RO	RO	RO	RO	RO	RO	RO	RO	RO
Reset	0	0	0	0	0	0	0	0	0	0	0	0	0	0	0	0
	15	14	13	12	11	10	9	8	7	6	5	4	3	2	1	0
	reserved						D9	D8	D7	D6	D5	D4	D3	D2	D1	D0
Type	RO	RO	RO	RO	RO	RO	RW	RW	RW	RW	RW	RW	RW	RW	RW	RW
Reset	0	0	0	0	0	0	0	0	0	0	0	0	0	0	0	0

Bit/Field	Name	Type	Reset	Description
31:10	reserved	RO	0	Software should not rely on the value of a reserved bit. To provide compatibility with future products, the value of a reserved bit should be preserved across a read-modify-write operation.
9	D9	RW	0	I ² C Module 9 Deep-Sleep Mode Clock Gating Control Value Description 0 I ² C module 9 is disabled in deep-sleep mode. 1 Enable and provide a clock to I ² C module 9 in deep-sleep mode.
8	D8	RW	0	I ² C Module 8 Deep-Sleep Mode Clock Gating Control Value Description 0 I ² C module 8 is disabled in deep-sleep mode. 1 Enable and provide a clock to I ² C module 8 in deep-sleep mode.
7	D7	RW	0	I ² C Module 7 Deep-Sleep Mode Clock Gating Control Value Description 0 I ² C module 7 is disabled in deep-sleep mode. 1 Enable and provide a clock to I ² C module 7 in deep-sleep mode.
6	D6	RW	0	I ² C Module 6 Deep-Sleep Mode Clock Gating Control Value Description 0 I ² C module 6 is disabled in deep-sleep mode. 1 Enable and provide a clock to I ² C module 6 in deep-sleep mode.

Bit/Field	Name	Type	Reset	Description
5	D5	RW	0	I ² C Module 5 Deep-Sleep Mode Clock Gating Control Value Description 0 I ² C module 5 is disabled in deep-sleep mode. 1 Enable and provide a clock to I ² C module 5 in deep-sleep mode.
4	D4	RW	0	I ² C Module 4 Deep-Sleep Mode Clock Gating Control Value Description 0 I ² C module 4 is disabled in deep-sleep mode. 1 Enable and provide a clock to I ² C module 4 in deep-sleep mode.
3	D3	RW	0	I ² C Module 3 Deep-Sleep Mode Clock Gating Control Value Description 0 I ² C module 3 is disabled in deep-sleep mode. 1 Enable and provide a clock to I ² C module 3 in deep-sleep mode.
2	D2	RW	0	I ² C Module 2 Deep-Sleep Mode Clock Gating Control Value Description 0 I ² C module 2 is disabled in deep-sleep mode. 1 Enable and provide a clock to I ² C module 2 in deep-sleep mode.
1	D1	RW	0	I ² C Module 1 Deep-Sleep Mode Clock Gating Control Value Description 0 I ² C module 1 is disabled in deep-sleep mode. 1 Enable and provide a clock to I ² C module 1 in deep-sleep mode.
0	D0	RW	0	I ² C Module 0 Deep-Sleep Mode Clock Gating Control Value Description 0 I ² C module 0 is disabled in deep-sleep mode. 1 Enable and provide a clock to I ² C module 0 in deep-sleep mode.

Register 134: Universal Serial Bus Deep-Sleep Mode Clock Gating Control (DCGCUSB), offset 0x828

The **DCGCUSB** register provides software the capability to enable and disable the USB module in deep-sleep mode. When enabled, a module is provided a clock. When disabled, the clock is disabled to save power.

Important: This register should be used to control the clocking for the USB module.

Universal Serial Bus Deep-Sleep Mode Clock Gating Control (DCGCUSB)

Base 0x400F.E000
 Offset 0x828
 Type RW, reset 0x0000.0000

	31	30	29	28	27	26	25	24	23	22	21	20	19	18	17	16
	reserved															
Type	RO	RO	RO	RO	RO	RO	RO	RO	RO	RO	RO	RO	RO	RO	RO	RO
Reset	0	0	0	0	0	0	0	0	0	0	0	0	0	0	0	0
	15	14	13	12	11	10	9	8	7	6	5	4	3	2	1	0
	reserved															D0
Type	RO	RO	RO	RO	RO	RO	RO	RO	RO	RO	RO	RO	RO	RO	RO	RW
Reset	0	0	0	0	0	0	0	0	0	0	0	0	0	0	0	0

Bit/Field	Name	Type	Reset	Description
31:1	reserved	RO	0	Software should not rely on the value of a reserved bit. To provide compatibility with future products, the value of a reserved bit should be preserved across a read-modify-write operation.
0	D0	RW	0	USB Module Deep-Sleep Mode Clock Gating Control
				Value Description
				0 USB module is disabled in deep-sleep mode.
				1 Enable and provide a clock to the USB module in deep-sleep mode.

Register 135: Ethernet PHY Deep-Sleep Mode Clock Gating Control (DCGCEPHY), offset 0x830

The **DCGCEPHY** register provides software the capability to enable and disable the PHY module in deep-sleep mode. When enabled, a module is provided a clock. When disabled, the clock is disabled to save power.

Important: This register should be used to control the clocking for the PHY module.

Ethernet PHY Deep-Sleep Mode Clock Gating Control (DCGCEPHY)

Base 0x400F.E000

Offset 0x830

Type RW, reset 0x0000.0000

	31	30	29	28	27	26	25	24	23	22	21	20	19	18	17	16
	reserved															
Type	RO	RO	RO	RO	RO	RO	RO	RO	RO	RO	RO	RO	RO	RO	RO	RO
Reset	0	0	0	0	0	0	0	0	0	0	0	0	0	0	0	0
	15	14	13	12	11	10	9	8	7	6	5	4	3	2	1	0
	reserved															D0
Type	RO	RO	RO	RO	RO	RO	RO	RO	RO	RO	RO	RO	RO	RO	RO	RW
Reset	0	0	0	0	0	0	0	0	0	0	0	0	0	0	0	0

Bit/Field	Name	Type	Reset	Description
31:1	reserved	RO	0	Software should not rely on the value of a reserved bit. To provide compatibility with future products, the value of a reserved bit should be preserved across a read-modify-write operation.
0	D0	RW	0	PHY Module Deep-Sleep Mode Clock Gating Control
				Value Description
			0	PHY module is disabled in deep-sleep mode.
			1	Enable and provide a clock to the PHY module in deep-sleep mode.

Register 136: Controller Area Network Deep-Sleep Mode Clock Gating Control (DCGCCAN), offset 0x834

The **DCGCCAN** register provides software the capability to enable and disable the CAN modules in deep-sleep mode. When enabled, a module is provided a clock. When disabled, the clock is disabled to save power.

Important: This register should be used to control the clocking for the CAN modules.

Controller Area Network Deep-Sleep Mode Clock Gating Control (DCGCCAN)

Base 0x400F.E000
 Offset 0x834
 Type RW, reset 0x0000.0000

	31	30	29	28	27	26	25	24	23	22	21	20	19	18	17	16	
	reserved																
Type	RO	RO	RO	RO	RO	RO	RO	RO	RO	RO	RO	RO	RO	RO	RO	RO	
Reset	0	0	0	0	0	0	0	0	0	0	0	0	0	0	0	0	
	15	14	13	12	11	10	9	8	7	6	5	4	3	2	1	0	
	reserved															D1	D0
Type	RO	RO	RO	RO	RO	RO	RO	RO	RO	RO	RO	RO	RO	RO	RO	RW	RW
Reset	0	0	0	0	0	0	0	0	0	0	0	0	0	0	0	0	0

Bit/Field	Name	Type	Reset	Description
31:2	reserved	RO	0	Software should not rely on the value of a reserved bit. To provide compatibility with future products, the value of a reserved bit should be preserved across a read-modify-write operation.
1	D1	RW	0	CAN Module 1 Deep-Sleep Mode Clock Gating Control Value Description 0 CAN module 1 is disabled in deep-sleep mode. 1 Enable and provide a clock to CAN module 1 in deep-sleep mode.
0	D0	RW	0	CAN Module 0 Deep-Sleep Mode Clock Gating Control Value Description 0 CAN module 0 is disabled in deep-sleep mode. 1 Enable and provide a clock to CAN module 0 in deep-sleep mode.

Register 137: Analog-to-Digital Converter Deep-Sleep Mode Clock Gating Control (DCGCADC), offset 0x838

The **DCGCADC** register provides software the capability to enable and disable the ADC modules in deep-sleep mode. When enabled, a module is provided a clock. When disabled, the clock is disabled to save power.

Important: This register should be used to control the clocking for the ADC modules.

Analog-to-Digital Converter Deep-Sleep Mode Clock Gating Control (DCGCADC)

Base 0x400F.E000
Offset 0x838
Type RW, reset 0x0000.0000

	31	30	29	28	27	26	25	24	23	22	21	20	19	18	17	16	
	reserved																
Type	RO	RO	RO	RO	RO	RO	RO	RO	RO	RO	RO	RO	RO	RO	RO	RO	
Reset	0	0	0	0	0	0	0	0	0	0	0	0	0	0	0	0	
	15	14	13	12	11	10	9	8	7	6	5	4	3	2	1	0	
	reserved															D1	D0
Type	RO	RO	RO	RO	RO	RO	RO	RO	RO	RO	RO	RO	RO	RO	RW	RW	
Reset	0	0	0	0	0	0	0	0	0	0	0	0	0	0	0	0	

Bit/Field	Name	Type	Reset	Description
31:2	reserved	RO	0	Software should not rely on the value of a reserved bit. To provide compatibility with future products, the value of a reserved bit should be preserved across a read-modify-write operation.
1	D1	RW	0	ADC Module 1 Deep-Sleep Mode Clock Gating Control Value Description 0 ADC module 1 is disabled in deep-sleep mode. 1 Enable and provide a clock to ADC module 1 in deep-sleep mode.
0	D0	RW	0	ADC Module 0 Deep-Sleep Mode Clock Gating Control Value Description 0 ADC module 0 is disabled in deep-sleep mode. 1 Enable and provide a clock to ADC module 0 in deep-sleep mode.

Register 138: Analog Comparator Deep-Sleep Mode Clock Gating Control (DCGCACMP), offset 0x83C

The **DCGCACMP** register provides software the capability to enable and disable the analog comparator module in deep-sleep mode. When enabled, a module is provided a clock. When disabled, the clock is disabled to save power.

Important: This register should be used to control the clocking for the analog comparator module.

Analog Comparator Deep-Sleep Mode Clock Gating Control (DCGCACMP)

Base 0x400F.E000
 Offset 0x83C
 Type RW, reset 0x0000.0000

	31	30	29	28	27	26	25	24	23	22	21	20	19	18	17	16
	reserved															
Type	RO	RO	RO	RO	RO	RO	RO	RO	RO	RO	RO	RO	RO	RO	RO	RO
Reset	0	0	0	0	0	0	0	0	0	0	0	0	0	0	0	0
	15	14	13	12	11	10	9	8	7	6	5	4	3	2	1	0
	reserved															
																D0
Type	RO	RO	RO	RO	RO	RO	RO	RO	RO	RO	RO	RO	RO	RO	RO	RW
Reset	0	0	0	0	0	0	0	0	0	0	0	0	0	0	0	0

Bit/Field	Name	Type	Reset	Description
31:1	reserved	RO	0	Software should not rely on the value of a reserved bit. To provide compatibility with future products, the value of a reserved bit should be preserved across a read-modify-write operation.
0	D0	RW	0	Analog Comparator Module 0 Deep-Sleep Mode Clock Gating Control
				Value Description
			0	Analog comparator module is disabled in deep-sleep mode.
			1	Enable and provide a clock to the analog comparator module in deep-sleep mode.

Register 139: Pulse Width Modulator Deep-Sleep Mode Clock Gating Control (DCGCPWM), offset 0x840

The **DCGCPWM** register provides software the capability to enable and disable the PWM modules in deep-sleep mode. When enabled, a module is provided a clock. When disabled, the clock is disabled to save power.

Important: This register should be used to control the clocking for the PWM modules.

Pulse Width Modulator Deep-Sleep Mode Clock Gating Control (DCGCPWM)

Base 0x400F.E000

Offset 0x840

Type RW, reset 0x0000.0000

	31	30	29	28	27	26	25	24	23	22	21	20	19	18	17	16
	reserved															
Type	RO	RO	RO	RO	RO	RO	RO	RO	RO	RO	RO	RO	RO	RO	RO	RO
Reset	0	0	0	0	0	0	0	0	0	0	0	0	0	0	0	0
	15	14	13	12	11	10	9	8	7	6	5	4	3	2	1	0
	reserved															
Type	RO	RO	RO	RO	RO	RO	RO	RO	RO	RO	RO	RO	RO	RO	RO	RW
Reset	0	0	0	0	0	0	0	0	0	0	0	0	0	0	0	0

Bit/Field	Name	Type	Reset	Description
31:1	reserved	RO	0	Software should not rely on the value of a reserved bit. To provide compatibility with future products, the value of a reserved bit should be preserved across a read-modify-write operation.
0	D0	RW	0	PWM Module 0 Deep-Sleep Mode Clock Gating Control
				Value Description
			0	PWM module 0 is disabled in deep-sleep mode.
			1	Enable and provide a clock to PWM module 0 in deep-sleep mode.

Register 140: Quadrature Encoder Interface Deep-Sleep Mode Clock Gating Control (DCGCQEI), offset 0x844

The **DCGCQEI** register provides software the capability to enable and disable the QEI modules in deep-sleep mode. When enabled, a module is provided a clock. When disabled, the clock is disabled to save power.

Important: This register should be used to control the clocking for the QEI modules.

Quadrature Encoder Interface Deep-Sleep Mode Clock Gating Control (DCGCQEI)

Base 0x400F.E000
 Offset 0x844
 Type RW, reset 0x0000.0000

	31	30	29	28	27	26	25	24	23	22	21	20	19	18	17	16
	reserved															
Type	RO	RO	RO	RO	RO	RO	RO	RO	RO	RO	RO	RO	RO	RO	RO	RO
Reset	0	0	0	0	0	0	0	0	0	0	0	0	0	0	0	0
	15	14	13	12	11	10	9	8	7	6	5	4	3	2	1	0
	reserved															D0
Type	RO	RO	RO	RO	RO	RO	RO	RO	RO	RO	RO	RO	RO	RO	RO	RW
Reset	0	0	0	0	0	0	0	0	0	0	0	0	0	0	0	0

Bit/Field	Name	Type	Reset	Description
31:1	reserved	RO	0	Software should not rely on the value of a reserved bit. To provide compatibility with future products, the value of a reserved bit should be preserved across a read-modify-write operation.
0	D0	RW	0	QEI Module 0 Deep-Sleep Mode Clock Gating Control
				Value Description
			0	QEI module 0 is disabled in deep-sleep mode.
			1	Enable and provide a clock to QEI module 0 in deep-sleep mode.

Register 141: EEPROM Deep-Sleep Mode Clock Gating Control (DCGCEEPROM), offset 0x858

The **DCGCEEPROM** register provides software the capability to enable and disable the EEPROM module in deep-sleep mode. When enabled, a module is provided a clock. When disabled, the clock is disabled to save power.

EEPROM Deep-Sleep Mode Clock Gating Control (DCGCEEPROM)

Base 0x400F.E000

Offset 0x858

Type RW, reset 0x0000.0000

	31	30	29	28	27	26	25	24	23	22	21	20	19	18	17	16
	reserved															
Type	RO	RO	RO	RO	RO	RO	RO	RO	RO	RO	RO	RO	RO	RO	RO	RO
Reset	0	0	0	0	0	0	0	0	0	0	0	0	0	0	0	0
	15	14	13	12	11	10	9	8	7	6	5	4	3	2	1	0
	reserved															D0
Type	RO	RO	RO	RO	RO	RO	RO	RO	RO	RO	RO	RO	RO	RO	RO	RW
Reset	0	0	0	0	0	0	0	0	0	0	0	0	0	0	0	0

Bit/Field	Name	Type	Reset	Description
31:1	reserved	RO	0	Software should not rely on the value of a reserved bit. To provide compatibility with future products, the value of a reserved bit should be preserved across a read-modify-write operation.
0	D0	RW	0	EEPROM Module 0 Deep-Sleep Mode Clock Gating Control
Value Description				
	0			EEPROM module is disabled in deep-sleep mode.
	1			Enable and provide a clock to the EEPROM module in deep-sleep mode.

Register 142: CRC and Cryptographic Modules Deep-Sleep Mode Clock Gating Control (DCGCCM), offset 0x874

The **DCGCCM** register provides software the capability to enable and disable the CRC, AES, DES, and SHA/MD5 modules in deep-sleep mode. When enabled, the modules are provided a clock. When disabled, the clock is disabled to save power.

Important: This register should be used to control the clocking for the CRC, AES, DES, and SHA/MD5 modules.

CRC and Cryptographic Modules Deep-Sleep Mode Clock Gating Control (DCGCCM)

Base 0x400F.E000
 Offset 0x874
 Type RW, reset 0x0000.0000

	31	30	29	28	27	26	25	24	23	22	21	20	19	18	17	16
	reserved															
Type	RO	RO	RO	RO	RO	RO	RO	RO	RO	RO	RO	RO	RO	RO	RO	RO
Reset	0	0	0	0	0	0	0	0	0	0	0	0	0	0	0	0
	15	14	13	12	11	10	9	8	7	6	5	4	3	2	1	0
	reserved															D0
Type	RO	RO	RO	RO	RO	RO	RO	RO	RO	RO	RO	RO	RO	RO	RO	RW
Reset	0	0	0	0	0	0	0	0	0	0	0	0	0	0	0	0

Bit/Field	Name	Type	Reset	Description
31:1	reserved	RO	0	Software should not rely on the value of a reserved bit. To provide compatibility with future products, the value of a reserved bit should be preserved across a read-modify-write operation.
0	D0	RW	0	CRC and Cryptographic Modules Deep-Sleep Mode Clock Gating Control
				Value Description
			0	The CRC, AES, DES, and SHA/MD5 modules are disabled in deep-sleep mode.
			1	Enable and provide a clock to the CRC, AES, DES, and SHA/MD5 modules in deep-sleep mode.

Register 143: Ethernet MAC Deep-Sleep Mode Clock Gating Control (DCGCEMAC), offset 0x89C

The **DCGCEMAC** register provides software the capability to enable and disable the Ethernet MAC module in deep-sleep mode. When enabled, a module is provided a clock. When disabled, the clock is disabled to save power.

Important: This register should be used to control the clocking for the Ethernet MAC module.

Ethernet MAC Deep-Sleep Mode Clock Gating Control (DCGCEMAC)

Base 0x400F.E000

Offset 0x89C

Type RW, reset 0x0000.0000

	31	30	29	28	27	26	25	24	23	22	21	20	19	18	17	16
	reserved															
Type	RO	RO	RO	RO	RO	RO	RO	RO	RO	RO	RO	RO	RO	RO	RO	RO
Reset	0	0	0	0	0	0	0	0	0	0	0	0	0	0	0	0
	15	14	13	12	11	10	9	8	7	6	5	4	3	2	1	0
	reserved															
Type	RO	RO	RO	RO	RO	RO	RO	RO	RO	RO	RO	RO	RO	RO	RO	RW
Reset	0	0	0	0	0	0	0	0	0	0	0	0	0	0	0	0

Bit/Field	Name	Type	Reset	Description
31:1	reserved	RO	0	Software should not rely on the value of a reserved bit. To provide compatibility with future products, the value of a reserved bit should be preserved across a read-modify-write operation.
0	D0	RW	0	Ethernet MAC Module 0 Deep-Sleep Mode Clock Gating Control
				Value Description
			0	Ethernet MAC module 0 is disabled in deep-sleep mode.
			1	Enable and provide a clock to Ethernet MAC module 0 in deep-sleep mode.

Register 144: Watchdog Timer Power Control (PCWD), offset 0x900

Important: The Watchdog Timer modules do not currently provide the ability to respond to the power down request. Setting a bit in this register has no effect on power consumption. This register is defined for future software compatibility.

The **PCWD** register controls the power applied to the Watchdog Module module. The function of this bit depends on the current state of the device (Run, Sleep or Deep-Sleep mode) and value of the corresponding bits in the **RCGCWD**, **SCGCWD** and **DCGCWD** registers. If the R_n , S_n , or D_n bit of the respective **RCGCWD**, **SCGCWD** and **DCGCWD** registers is 1 and the device is in that mode, the module is powered and receives a clock irrespective of what the corresponding P_n bit in the **PCWD** register is.

However, if the R_n , S_n , or D_n bit of the respective **RCGCWD**, **SCGCWD** and **DCGCWD** registers is 0 and the device is in that mode, then the module behaves differently depending on the value of the corresponding P_n bit in the **PCWD** register. In this case, when the P_n bit is clear the module is not powered and does not receive a clock. If the P_n bit is set, the module is powered but does not receive a clock. The table below details the differences.

Table 5-16. Module Power Control

Rn, Sn or Dn Value in Respective RCGCx, SCGCx, or DCGCx Register	Pn	Description
0	0	Module is not powered and does not receive a clock. In this case, the peripheral's state is not retained. This is the lowest power consumption state of any peripheral since it consumes no dynamic nor leakage current. Hardware should perform a peripheral reset if the active mode changes and the RCGCx , SCGCx , or DCGCx register is a 1 or the P_0 bit is changed to a 1. Software must re-initialize the peripheral when re-enabled due to the loss of state.
0	1	Module is powered, but does not receive a clock. In this case, the peripheral is inactive. This is the second-lowest power consumption of any peripheral since it consumes only leakage current.
1	X	Module is powered and receives a clock.

Watchdog Timer Power Control (PCWD)

Base 0x400F.E000
Offset 0x900
Type RW, reset 0x0000.0003

	31	30	29	28	27	26	25	24	23	22	21	20	19	18	17	16	
	reserved																
Type	RO	RO	RO	RO	RO	RO	RO	RO	RO	RO	RO	RO	RO	RO	RO	RO	
Reset	0	0	0	0	0	0	0	0	0	0	0	0	0	0	0	0	
	15	14	13	12	11	10	9	8	7	6	5	4	3	2	1	0	
	reserved															P1	P0
Type	RO	RO	RO	RO	RO	RO	RO	RO	RO	RO	RO	RO	RO	RO	RO	RW	RW
Reset	0	0	0	0	0	0	0	0	0	0	0	0	0	0	0	1	1

Bit/Field	Name	Type	Reset	Description
31:2	reserved	RO	0	Software should not rely on the value of a reserved bit. To provide compatibility with future products, the value of a reserved bit should be preserved across a read-modify-write operation.

Bit/Field	Name	Type	Reset	Description
1	P1	RW	1	<p>Watchdog Timer 1 Power Control</p> <p>The P_n bit encodings are not applicable if the corresponding bit in the RCGCWD, SCGCWD or DCGCWD register is clear.</p> <p>Value Description</p> <p>0 Watchdog Timer 1 module is not powered and does not receive a clock. In this case, the module's state is not retained. This configuration provides the lowest power consumption state.</p> <p>1 Watchdog Timer 1 module is powered, but does not receive a clock. In this case, the module is inactive.</p>
0	P0	RW	1	<p>Watchdog Timer 0 Power Control</p> <p>The P_n bit encodings are not applicable if the corresponding bit in the RCGCWD, SCGCWD or DCGCWD register is clear.</p> <p>Value Description</p> <p>0 Watchdog Timer 0 module is not powered and does not receive a clock. In this case, the module's state is not retained. This configuration provides the lowest power consumption state.</p> <p>1 Watchdog Timer 0 module is powered, but does not receive a clock. In this case, the module is inactive.</p>

Register 145: 16/32-Bit General-Purpose Timer Power Control (PCTIMER), offset 0x904

Important: The Timer module does not currently provide the ability to respond to the power down request. Setting a bit in this register has no effect on power consumption. This register is defined for future software compatibility.

The **PCTIMER** register controls the power applied to the Timer module. The function of this bit depends on the current state of the device (Run, Sleep or Deep-Sleep mode) and value of the corresponding bits in the **RCGCTIMER**, **SCGCTIMER** and **DCGCTIMER** registers. If the R_n , S_n , or D_n bit of the respective **RCGCTIMER**, **SCGCTIMER** and **DCGCTIMER** registers is 1 and the device is in that mode, the module is powered and receives a clock irrespective of what the corresponding P_n bit in the **PCTIMER** register is.

However, if the R_n , S_n , or D_n bit of the respective **RCGCTIMER**, **SCGCTIMER** and **DCGCTIMER** registers is 0 and the device is in that mode, then the module behaves differently depending on the value of the corresponding P_n bit in the **PCTIMER** register. In this case, when the P_n bit is clear the module is not powered and does not receive a clock. If the P_n bit is set, the module is powered but does not receive a clock. The table below details the differences.

Table 5-17. Module Power Control

Rn, Sn or Dn Value in Respective RCGCx, SCGCx, or DCGCx Register	Pn	Description
0	0	Module is not powered and does not receive a clock. In this case, the peripheral's state is not retained. This is the lowest power consumption state of any peripheral since it consumes no dynamic nor leakage current. Hardware should perform a peripheral reset if the active mode changes and the RCGCx , SCGCx , or DCGCx register is a 1 or the P_0 bit is changed to a 1. Software must re-initialize the peripheral when re-enabled due to the loss of state.
0	1	Module is powered, but does not receive a clock. In this case, the peripheral is inactive. This is the second-lowest power consumption of any peripheral since it consumes only leakage current.
1	X	Module is powered and receives a clock.

16/32-Bit General-Purpose Timer Power Control (PCTIMER)

Base 0x400F.E000
Offset 0x904
Type RW, reset 0x0000.00FF

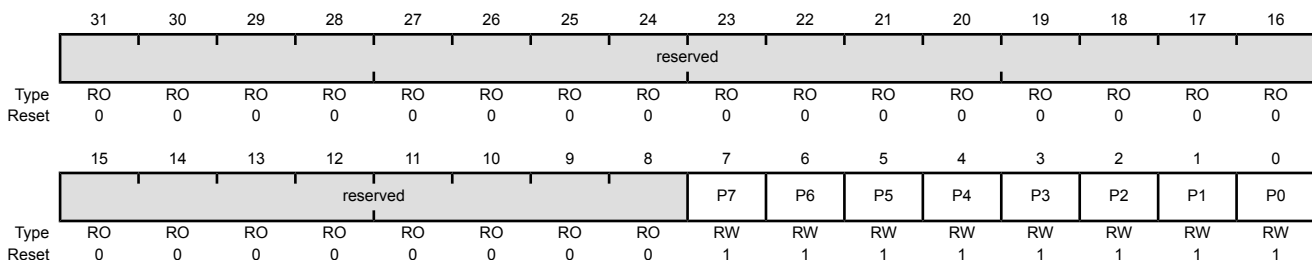

Bit/Field	Name	Type	Reset	Description
31:8	reserved	RO	0	Software should not rely on the value of a reserved bit. To provide compatibility with future products, the value of a reserved bit should be preserved across a read-modify-write operation.
7	P7	RW	1	<p>General-Purpose Timer 7 Power Control</p> <p>The P_n bit encodings are not applicable if the corresponding bit in the RCGTIMER, SCGTIMER or DCGTIMER register is clear.</p> <p>Value Description</p> <p>0 Timer 7 module is not powered and does not receive a clock. In this case, the module's state is not retained. This configuration provides the lowest power consumption state.</p> <p>1 Timer 7 module is powered, but does not receive a clock. In this case, the module is inactive.</p>
6	P6	RW	1	<p>General-Purpose Timer 6 Power Control</p> <p>The P_n bit encodings are not applicable if the corresponding bit in the RCGTIMER, SCGTIMER or DCGTIMER register is clear.</p> <p>Value Description</p> <p>0 Timer 6 module is not powered and does not receive a clock. In this case, the module's state is not retained. This configuration provides the lowest power consumption state.</p> <p>1 Timer 6 module is powered, but does not receive a clock. In this case, the module is inactive.</p>
5	P5	RW	1	<p>General-Purpose Timer 5 Power Control</p> <p>The P_n bit encodings are not applicable if the corresponding bit in the RCGTIMER, SCGTIMER or DCGTIMER register is clear.</p> <p>Value Description</p> <p>0 Timer 5 module is not powered and does not receive a clock. In this case, the module's state is not retained. This configuration provides the lowest power consumption state.</p> <p>1 Timer 5 module is powered, but does not receive a clock. In this case, the module is inactive.</p>
4	P4	RW	1	<p>General-Purpose Timer 4 Power Control</p> <p>The P_n bit encodings are not applicable if the corresponding bit in the RCGTIMER, SCGTIMER or DCGTIMER register is clear.</p> <p>Value Description</p> <p>0 Timer 4 module is not powered and does not receive a clock. In this case, the module's state is not retained. This configuration provides the lowest power consumption state.</p> <p>1 Timer 4 module is powered, but does not receive a clock. In this case, the module is inactive.</p>

Bit/Field	Name	Type	Reset	Description
3	P3	RW	1	<p>General-Purpose Timer 3 Power Control</p> <p>The P_n bit encodings are not applicable if the corresponding bit in the RCGCTIMER, SCGCTIMER or DCGCTIMER register is clear.</p> <p>Value Description</p> <p>0 Timer 3 module is not powered and does not receive a clock. In this case, the module's state is not retained. This configuration provides the lowest power consumption state.</p> <p>1 Timer 3 module is powered, but does not receive a clock. In this case, the module is inactive.</p>
2	P2	RW	1	<p>General-Purpose Timer 2 Power Control</p> <p>The P_n bit encodings are not applicable if the corresponding bit in the RCGCTIMER, SCGCTIMER or DCGCTIMER register is clear.</p> <p>Value Description</p> <p>0 Timer 2 module is not powered and does not receive a clock. In this case, the module's state is not retained. This configuration provides the lowest power consumption state.</p> <p>1 Timer 2 module is powered, but does not receive a clock. In this case, the module is inactive.</p>
1	P1	RW	1	<p>General-Purpose Timer 1 Power Control</p> <p>The P_n bit encodings are not applicable if the corresponding bit in the RCGCTIMER, SCGCTIMER or DCGCTIMER register is clear.</p> <p>Value Description</p> <p>0 Timer 1 module is not powered and does not receive a clock. In this case, the module's state is not retained. This configuration provides the lowest power consumption state.</p> <p>1 Timer 1 module is powered, but does not receive a clock. In this case, the module is inactive.</p>
0	P0	RW	1	<p>General-Purpose Timer 0 Power Control</p> <p>The P_n bit encodings are not applicable if the corresponding bit in the RCGCTIMER, SCGCTIMER or DCGCTIMER register is clear.</p> <p>Value Description</p> <p>0 Timer 0 module is not powered and does not receive a clock. In this case, the module's state is not retained. This configuration provides the lowest power consumption state.</p> <p>1 Timer 0 module is powered, but does not receive a clock. In this case, the module is inactive.</p>

Register 146: General-Purpose Input/Output Power Control (PCGPIO), offset 0x908

Important: The GPIO modules do not currently provide the ability to respond to the power down request. Setting a bit in this register has no effect on power consumption. This register is defined for future software compatibility.

The **PCGPIO** register controls the power applied to the GPIO module. The function of this bit depends on the current state of the device (Run, Sleep or Deep-Sleep mode) and value of the corresponding bits in the **RCGCGPIO**, **SCGCGPIO** and **DCGCGPIO** registers. If the R_n , S_n , or D_n bit of the respective **RCGCGPIO**, **SCGCGPIO** and **DCGCGPIO** registers is 1 and the device is in that mode, the module is powered and receives a clock irrespective of what the corresponding P_n bit in the **PCGPIO** register is.

However, if the R_n , S_n , or D_n bit of the respective **RCGCGPIO**, **SCGCGPIO** and **DCGCGPIO** registers is 0 and the device is in that mode, then the module behaves differently depending on the value of the corresponding P_n bit in the **PCGPIO** register. In this case, when the P_n bit is clear the module is not powered and does not receive a clock. If the P_n bit is set, the module is powered but does not receive a clock. The table below details the differences.

Table 5-18. Module Power Control

R_n , S_n or D_n Value in Respective RCGCx, SCGCx, or DCGCx Register	P_n	Description
0	0	Module is not powered and does not receive a clock. In this case, the peripheral's state is not retained. This is the lowest power consumption state of any peripheral since it consumes no dynamic nor leakage current. Hardware should perform a peripheral reset if the active mode changes and the RCGCx , SCGCx , or DCGCx register is a 1 or the P_0 bit is changed to a 1. Software must re-initialize the peripheral when re-enabled due to the loss of state.
0	1	Module is powered, but does not receive a clock. In this case, the peripheral is inactive. This is the second-lowest power consumption of any peripheral since it consumes only leakage current.
1	X	Module is powered and receives a clock.

General-Purpose Input/Output Power Control (PCGPIO)

Base 0x400F.E000
Offset 0x908
Type RW, reset 0x0000.7FFF

	31	30	29	28	27	26	25	24	23	22	21	20	19	18	17	16
	reserved															
Type	RO	RO	RO	RO	RO	RO	RO	RO	RO	RO	RO	RO	RO	RO	RO	RO
Reset	0	0	0	0	0	0	0	0	0	0	0	0	0	0	0	0
	15	14	13	12	11	10	9	8	7	6	5	4	3	2	1	0
	reserved	P14	P13	P12	P11	P10	P9	P8	P7	P6	P5	P4	P3	P2	P1	P0
Type	RO	RW	RW	RW	RW	RW	RW	RW	RW	RW	RW	RW	RW	RW	RW	RW
Reset	0	1	1	1	1	1	1	1	1	1	1	1	1	1	1	1

Bit/Field	Name	Type	Reset	Description
31:15	reserved	RO	0	Software should not rely on the value of a reserved bit. To provide compatibility with future products, the value of a reserved bit should be preserved across a read-modify-write operation.
14	P14	RW	1	<p>GPIO Port Q Power Control</p> <p>The Pn bit encodings are not applicable if the corresponding bit in the RCGCGPIO, SCGCGPIO or DCGCGPIO register is clear.</p> <p>Value Description</p> <p>0 GPIO Port Q is not powered and does not receive a clock. In this case, the module's state is not retained. This configuration provides the lowest power consumption state.</p> <p>1 GPIO Port Q is powered, but does not receive a clock. In this case, the module is inactive.</p>
13	P13	RW	1	<p>GPIO Port P Power Control</p> <p>The Pn bit encodings are not applicable if the corresponding bit in the RCGCGPIO, SCGCGPIO or DCGCGPIO register is clear.</p> <p>Value Description</p> <p>0 GPIO Port P is not powered and does not receive a clock. In this case, the module's state is not retained. This configuration provides the lowest power consumption state.</p> <p>1 GPIO Port P is powered, but does not receive a clock. In this case, the module is inactive.</p>
12	P12	RW	1	<p>GPIO Port N Power Control</p> <p>The Pn bit encodings are not applicable if the corresponding bit in the RCGCGPIO, SCGCGPIO or DCGCGPIO register is clear.</p> <p>Value Description</p> <p>0 GPIO Port N is not powered and does not receive a clock. In this case, the module's state is not retained. This configuration provides the lowest power consumption state.</p> <p>1 GPIO Port N is powered, but does not receive a clock. In this case, the module is inactive.</p>
11	P11	RW	1	<p>GPIO Port M Power Control</p> <p>The Pn bit encodings are not applicable if the corresponding bit in the RCGCGPIO, SCGCGPIO or DCGCGPIO register is clear.</p> <p>Value Description</p> <p>0 GPIO Port M is not powered and does not receive a clock. In this case, the module's state is not retained. This configuration provides the lowest power consumption state.</p> <p>1 GPIO Port M is powered, but does not receive a clock. In this case, the module is inactive.</p>

Bit/Field	Name	Type	Reset	Description
10	P10	RW	1	<p>GPIO Port L Power Control</p> <p>The Pn bit encodings are not applicable if the corresponding bit in the RCGCGPIO, SCGCGPIO or DCGCGPIO register is clear.</p> <p>Value Description</p> <p>0 GPIO Port L is not powered and does not receive a clock. In this case, the module's state is not retained. This configuration provides the lowest power consumption state.</p> <p>1 GPIO Port L is powered, but does not receive a clock. In this case, the module is inactive.</p>
9	P9	RW	1	<p>GPIO Port K Power Control</p> <p>The Pn bit encodings are not applicable if the corresponding bit in the RCGCGPIO, SCGCGPIO or DCGCGPIO register is clear.</p> <p>Value Description</p> <p>0 GPIO Port K is not powered and does not receive a clock. In this case, the module's state is not retained. This configuration provides the lowest power consumption state.</p> <p>1 GPIO Port K is powered, but does not receive a clock. In this case, the module is inactive.</p>
8	P8	RW	1	<p>GPIO Port J Power Control</p> <p>The Pn bit encodings are not applicable if the corresponding bit in the RCGCGPIO, SCGCGPIO or DCGCGPIO register is clear.</p> <p>Value Description</p> <p>0 GPIO Port J is not powered and does not receive a clock. In this case, the module's state is not retained. This configuration provides the lowest power consumption state.</p> <p>1 GPIO Port J is powered, but does not receive a clock. In this case, the module is inactive.</p>
7	P7	RW	1	<p>GPIO Port H Power Control</p> <p>The Pn bit encodings are not applicable if the corresponding bit in the RCGCGPIO, SCGCGPIO or DCGCGPIO register is clear.</p> <p>Value Description</p> <p>0 GPIO Port H is not powered and does not receive a clock. In this case, the module's state is not retained. This configuration provides the lowest power consumption state.</p> <p>1 GPIO Port H is powered, but does not receive a clock. In this case, the module is inactive.</p>

Bit/Field	Name	Type	Reset	Description
6	P6	RW	1	<p>GPIO Port G Power Control</p> <p>The Pn bit encodings are not applicable if the corresponding bit in the RCGCGPIO, SCGCGPIO or DCGCGPIO register is clear.</p> <p>Value Description</p> <p>0 GPIO Port G is not powered and does not receive a clock. In this case, the module's state is not retained. This configuration provides the lowest power consumption state.</p> <p>1 GPIO Port G is powered, but does not receive a clock. In this case, the module is inactive.</p>
5	P5	RW	1	<p>GPIO Port F Power Control</p> <p>The Pn bit encodings are not applicable if the corresponding bit in the RCGCGPIO, SCGCGPIO or DCGCGPIO register is clear.</p> <p>Value Description</p> <p>0 GPIO Port F is not powered and does not receive a clock. In this case, the module's state is not retained. This configuration provides the lowest power consumption state.</p> <p>1 GPIO Port F is powered, but does not receive a clock. In this case, the module is inactive.</p>
4	P4	RW	1	<p>GPIO Port E Power Control</p> <p>The Pn bit encodings are not applicable if the corresponding bit in the RCGCGPIO, SCGCGPIO or DCGCGPIO register is clear.</p> <p>Value Description</p> <p>0 GPIO Port E is not powered and does not receive a clock. In this case, the module's state is not retained. This configuration provides the lowest power consumption state.</p> <p>1 GPIO Port E is powered, but does not receive a clock. In this case, the module is inactive.</p>
3	P3	RW	1	<p>GPIO Port D Power Control</p> <p>The Pn bit encodings are not applicable if the corresponding bit in the RCGCGPIO, SCGCGPIO or DCGCGPIO register is clear.</p> <p>Value Description</p> <p>0 GPIO Port D is not powered and does not receive a clock. In this case, the module's state is not retained. This configuration provides the lowest power consumption state.</p> <p>1 GPIO Port D is powered, but does not receive a clock. In this case, the module is inactive.</p>

Bit/Field	Name	Type	Reset	Description
2	P2	RW	1	<p>GPIO Port C Power Control</p> <p>The Pn bit encodings are not applicable if the corresponding bit in the RCGCGPIO, SCGCGPIO or DCGCGPIO register is clear.</p> <p>Value Description</p> <p>0 GPIO Port C is not powered and does not receive a clock. In this case, the module's state is not retained. This configuration provides the lowest power consumption state.</p> <p>1 GPIO Port C is powered, but does not receive a clock. In this case, the module is inactive.</p>
1	P1	RW	1	<p>GPIO Port B Power Control</p> <p>The Pn bit encodings are not applicable if the corresponding bit in the RCGCGPIO, SCGCGPIO or DCGCGPIO register is clear.</p> <p>Value Description</p> <p>0 GPIO Port B is not powered and does not receive a clock. In this case, the module's state is not retained. This configuration provides the lowest power consumption state.</p> <p>1 GPIO Port B is powered, but does not receive a clock. In this case, the module is inactive.</p>
0	P0	RW	1	<p>GPIO Port A Power Control</p> <p>The Pn bit encodings are not applicable if the corresponding bit in the RCGCGPIO, SCGCGPIO or DCGCGPIO register is clear.</p> <p>Value Description</p> <p>0 GPIO Port A is not powered and does not receive a clock. In this case, the module's state is not retained. This configuration provides the lowest power consumption state.</p> <p>1 GPIO Port A is powered, but does not receive a clock. In this case, the module is inactive.</p>

Register 147: Micro Direct Memory Access Power Control (PCDMA), offset 0x90C

Important: The μ DMA module does not currently provide the ability to respond to the power down request. Setting a bit in this register has no effect on power consumption. This register is defined for future software compatibility.

The **PCDMA** register controls the power applied to the DMA module. The function of this bit depends on the current state of the device (Run, Sleep or Deep-Sleep mode) and value of the corresponding bits in the **RCGCDMA**, **SCGCDMA** and **DCGCDMA** registers. If the R_n , S_n , or D_n bit of the respective **RCGCDMA**, **SCGCDMA** and **DCGCDMA** registers is 1 and the device is in that mode, the module is powered and receives a clock irrespective of what the corresponding P_n bit in the **PCDMA** register is.

However, if the R_n , S_n , or D_n bit of the respective **RCGCDMA**, **SCGCDMA** and **DCGCDMA** registers is 0 and the device is in that mode, then the module behaves differently depending on the value of the corresponding P_n bit in the **PCDMA** register. In this case, when the P_n bit is clear the module is not powered and does not receive a clock. If the P_n bit is set, the module is powered but does not receive a clock. The table below details the differences.

Table 5-19. Module Power Control

R _n , S _n or D _n Value in Respective RCGC _x , SCGC _x , or DCGC _x Register	P _n	Description
0	0	Module is not powered and does not receive a clock. In this case, the peripheral's state is not retained. This is the lowest power consumption state of any peripheral since it consumes no dynamic nor leakage current. Hardware should perform a peripheral reset if the active mode changes and the RCGC_x , SCGC_x , or DCGC_x register is a 1 or the P0 bit is changed to a 1. Software must re-initialize the peripheral when re-enabled due to the loss of state.
0	1	Module is powered, but does not receive a clock. In this case, the peripheral is inactive. This is the second-lowest power consumption of any peripheral since it consumes only leakage current.
1	X	Module is powered and receives a clock.

Micro Direct Memory Access Power Control (PCDMA)

Base 0x400F.E000
Offset 0x90C
Type RW, reset 0x0000.0001

	31	30	29	28	27	26	25	24	23	22	21	20	19	18	17	16
	reserved															
Type	RO	RO	RO	RO	RO	RO	RO	RO	RO	RO	RO	RO	RO	RO	RO	RO
Reset	0	0	0	0	0	0	0	0	0	0	0	0	0	0	0	0
	15	14	13	12	11	10	9	8	7	6	5	4	3	2	1	0
	reserved															P0
Type	RO	RO	RO	RO	RO	RO	RO	RO	RO	RO	RO	RO	RO	RO	RO	RW
Reset	0	0	0	0	0	0	0	0	0	0	0	0	0	0	0	1

Bit/Field	Name	Type	Reset	Description
31:1	reserved	RO	0	Software should not rely on the value of a reserved bit. To provide compatibility with future products, the value of a reserved bit should be preserved across a read-modify-write operation.
0	P0	RW	1	<p>μDMA Module Power Control</p> <p>The Pn bit encodings are not applicable if the corresponding bit in the RCGCDMA, SCGCDMA or DCGCDMA register is clear.</p> <p>Value Description</p> <p>0 The μDMA module is not powered and does not receive a clock. In this case, the module's state is not retained. This configuration provides the lowest power consumption state.</p> <p>1 The μDMA module is powered, but does not receive a clock. In this case, the module is inactive.</p>

Register 148: External Peripheral Interface Power Control (PCEPI), offset 0x910

Important: The EPI module does not currently provide the ability to respond to the power down request. Setting a bit in this register has no effect on power consumption. This register is defined for future software compatibility.

The **PCEPI** register controls the power applied to the EPI module. The function of this bit depends on the current state of the device (Run, Sleep or Deep-Sleep mode) and value of the corresponding bits in the **RCGCEPI**, **SCGCEPI** and **DCGCEPI** registers. If the R_n , S_n , or D_n bit of the respective **RCGCEPI**, **SCGCEPI** and **DCGCEPI** registers is 1 and the device is in that mode, the module is powered and receives a clock irrespective of what the corresponding P_n bit in the **PCEPI** register is.

However, if the R_n , S_n , or D_n bit of the respective **RCGCEPI**, **SCGCEPI** and **DCGCEPI** registers is 0 and the device is in that mode, then the module behaves differently depending on the value of the corresponding P_n bit in the **PCEPI** register. In this case, when the P_n bit is clear the module is not powered and does not receive a clock. If the P_n bit is set, the module is powered but does not receive a clock. The table below details the differences.

Table 5-20. Module Power Control

R _n , S _n or D _n Value in Respective RCGC _x , SCGC _x , or DCGC _x Register	P _n	Description
0	0	Module is not powered and does not receive a clock. In this case, the peripheral's state is not retained. This is the lowest power consumption state of any peripheral since it consumes no dynamic nor leakage current. Hardware should perform a peripheral reset if the active mode changes and the RCGC_x , SCGC_x , or DCGC_x register is a 1 or the P0 bit is changed to a 1. Software must re-initialize the peripheral when re-enabled due to the loss of state.
0	1	Module is powered, but does not receive a clock. In this case, the peripheral is inactive. This is the second-lowest power consumption of any peripheral since it consumes only leakage current.
1	X	Module is powered and receives a clock.

External Peripheral Interface Power Control (PCEPI)

Base 0x400F.E000
Offset 0x910
Type RW, reset 0x0000.0001

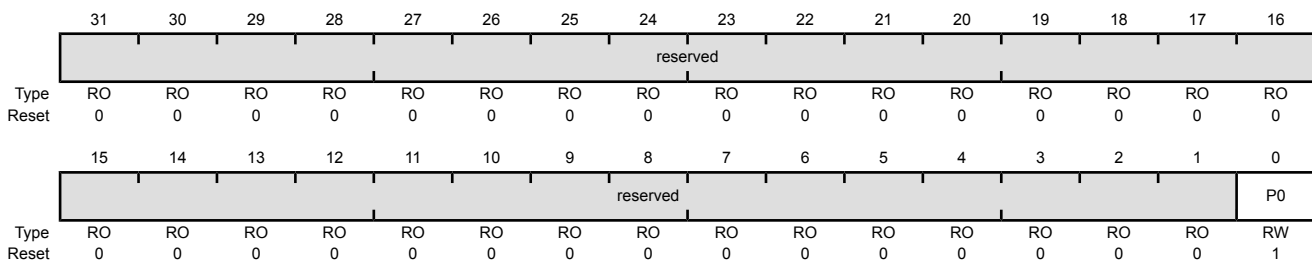

Bit/Field	Name	Type	Reset	Description
31:1	reserved	RO	0	Software should not rely on the value of a reserved bit. To provide compatibility with future products, the value of a reserved bit should be preserved across a read-modify-write operation.
0	P0	RW	1	<p>EPI Module Power Control</p> <p>The Pn bit encodings are not applicable if the corresponding bit in the RCGCEPI, SCGCEPI or DCGCEPI register is clear.</p> <p>Value Description</p> <p>0 The EPI module is not powered and does not receive a clock. In this case, the module's state is not retained. This configuration provides the lowest power consumption state.</p> <p>1 The EPI module is powered, but does not receive a clock. In this case, the module is inactive.</p>

Register 149: Hibernation Power Control (PCHIB), offset 0x914

Important: The Hibernation module does not currently provide the ability to respond to the power down request. Setting a bit in this register has no effect on power consumption. This register is defined for future software compatibility.

The **PCHIB** register controls the power applied to the HIB module. The function of this bit depends on the current state of the device (Run, Sleep or Deep-Sleep mode) and value of the corresponding bits in the **RCGCx**, **SCGCx** and **DCGCx** registers. If the R_n , S_n , or D_n bit of the respective **RCGCx**, **SCGCx** and **DCGCx** registers is 1 and the device is in that mode, the module is powered and receives a clock irrespective of what the corresponding P_n bit in the **PCHIB** register is.

However, if the R_n , S_n , or D_n bit of the respective **RCGCx**, **SCGCx** and **DCGCx** registers is 0 and the device is in that mode, then the module behaves differently depending on the value of the corresponding P_n bit in the **PCHIB** register. In this case, when the P_n bit is clear the module is not powered and does not receive a clock. If the P_n bit is set, the module is powered but does not receive a clock. The table below details the differences.

Table 5-21. Module Power Control

Rn, Sn or Dn Value in Respective RCGCx, SCGCx, or DCGCx Register	Pn	Description
0	0	Module is not powered and does not receive a clock. In this case, the peripheral's state is not retained. This is the lowest power consumption state of any peripheral since it consumes no dynamic nor leakage current. Hardware should perform a peripheral reset if the active mode changes and the RCGCx , SCGCx , or DCGCx register is a 1 or the P_0 bit is changed to a 1. Software must re-initialize the peripheral when re-enabled due to the loss of state.
0	1	Module is powered, but does not receive a clock. In this case, the peripheral is inactive. This is the second-lowest power consumption of any peripheral since it consumes only leakage current.
1	X	Module is powered and receives a clock.

Hibernation Power Control (PCHIB)

Base 0x400F.E000
Offset 0x914
Type RW, reset 0x0000.0001

	31	30	29	28	27	26	25	24	23	22	21	20	19	18	17	16
	reserved															
Type	RO	RO	RO	RO	RO	RO	RO	RO	RO	RO	RO	RO	RO	RO	RO	RO
Reset	0	0	0	0	0	0	0	0	0	0	0	0	0	0	0	0
	15	14	13	12	11	10	9	8	7	6	5	4	3	2	1	0
	reserved															P0
Type	RO	RO	RO	RO	RO	RO	RO	RO	RO	RO	RO	RO	RO	RO	RO	RW
Reset	0	0	0	0	0	0	0	0	0	0	0	0	0	0	0	1

Bit/Field	Name	Type	Reset	Description
31:1	reserved	RO	0	Software should not rely on the value of a reserved bit. To provide compatibility with future products, the value of a reserved bit should be preserved across a read-modify-write operation.

Bit/Field	Name	Type	Reset	Description
0	P0	RW	1	<p>Hibernation Module Power Control</p> <p>The Pn bit encodings are not applicable if the corresponding bit in the RCGCHIB, SCGCHIB or DCGCHIB register is clear.</p> <p>Value Description</p> <p>0 The HIB module is not powered and does not receive a clock. In this case, the module's state is not retained. This configuration provides the lowest power consumption state.</p> <p>1 The HIB module is powered, but does not receive a clock. In this case, the module is inactive.</p>

Register 150: Universal Asynchronous Receiver/Transmitter Power Control (PCUART), offset 0x918

Important: The UART module does not currently provide the ability to respond to the power down request. Setting a bit in this register has no effect on power consumption. This register is defined for future software compatibility.

The **PCUART** register controls the power applied to the UART module. The function of this bit depends on the current state of the device (Run, Sleep or Deep-Sleep mode) and value of the corresponding bits in the **RCGCUART**, **SCGCUART** and **DCGCUART** registers. If the R_n , S_n , or D_n bit of the respective **RCGCUART**, **SCGCUART** and **DCGCUART** registers is 1 and the device is in that mode, the module is powered and receives a clock irrespective of what the corresponding P_n bit in the **PCUART** register is.

However, if the R_n , S_n , or D_n bit of the respective **RCGCUART**, **SCGCUART** and **DCGCUART** registers is 0 and the device is in that mode, then the module behaves differently depending on the value of the corresponding P_n bit in the **PCUART** register. In this case, when the P_n bit is clear the module is not powered and does not receive a clock. If the P_n bit is set, the module is powered but does not receive a clock. The table below details the differences.

Table 5-22. Module Power Control

R_n , S_n or D_n Value in Respective RCGCx, SCGCx, or DGCx Register	P_n	Description
0	0	Module is not powered and does not receive a clock. In this case, the peripheral's state is not retained. This is the lowest power consumption state of any peripheral since it consumes no dynamic nor leakage current. Hardware should perform a peripheral reset if the active mode changes and the RCGCx, SCGCx, or DGCx register is a 1 or the P_0 bit is changed to a 1. Software must re-initialize the peripheral when re-enabled due to the loss of state.
0	1	Module is powered, but does not receive a clock. In this case, the peripheral is inactive. This is the second-lowest power consumption of any peripheral since it consumes only leakage current.
1	X	Module is powered and receives a clock.

Universal Asynchronous Receiver/Transmitter Power Control (PCUART)

Base 0x400F.E000
Offset 0x918
Type RW, reset 0x0000.00FF

	31	30	29	28	27	26	25	24	23	22	21	20	19	18	17	16
	reserved															
Type	RO	RO	RO	RO	RO	RO	RO	RO	RO	RO	RO	RO	RO	RO	RO	RO
Reset	0	0	0	0	0	0	0	0	0	0	0	0	0	0	0	0
	15	14	13	12	11	10	9	8	7	6	5	4	3	2	1	0
	reserved								P7	P6	P5	P4	P3	P2	P1	P0
Type	RO	RO	RO	RO	RO	RO	RO	RO	RW	RW	RW	RW	RW	RW	RW	RW
Reset	0	0	0	0	0	0	0	0	1	1	1	1	1	1	1	1

Bit/Field	Name	Type	Reset	Description
31:8	reserved	RO	0	Software should not rely on the value of a reserved bit. To provide compatibility with future products, the value of a reserved bit should be preserved across a read-modify-write operation.
7	P7	RW	1	<p>UART Module 7 Power Control</p> <p>The P_n bit encodings are not applicable if the corresponding bit in the RCGCUART, SCGCUART or DCGCUART register is clear.</p> <p>Value Description</p> <p>0 The UART module 7 is not powered and does not receive a clock. In this case, the module's state is not retained. This configuration provides the lowest power consumption state.</p> <p>1 The UART module 7 is powered, but does not receive a clock. In this case, the module is inactive.</p>
6	P6	RW	1	<p>UART Module 6 Power Control</p> <p>The P_n bit encodings are not applicable if the corresponding bit in the RCGCUART, SCGCUART or DCGCUART register is clear.</p> <p>Value Description</p> <p>0 The UART module 6 is not powered and does not receive a clock. In this case, the module's state is not retained. This configuration provides the lowest power consumption state.</p> <p>1 The UART module 6 is powered, but does not receive a clock. In this case, the module is inactive.</p>
5	P5	RW	1	<p>UART Module 5 Power Control</p> <p>The P_n bit encodings are not applicable if the corresponding bit in the RCGCUART, SCGCUART or DCGCUART register is clear.</p> <p>Value Description</p> <p>0 The UART module 5 is not powered and does not receive a clock. In this case, the module's state is not retained. This configuration provides the lowest power consumption state.</p> <p>1 The UART module 5 is powered, but does not receive a clock. In this case, the module is inactive.</p>
4	P4	RW	1	<p>UART Module 4 Power Control</p> <p>The P_n bit encodings are not applicable if the corresponding bit in the RCGCUART, SCGCUART or DCGCUART register is clear.</p> <p>Value Description</p> <p>0 The UART module 4 is not powered and does not receive a clock. In this case, the module's state is not retained. This configuration provides the lowest power consumption state.</p> <p>1 The UART module 4 is powered, but does not receive a clock. In this case, the module is inactive.</p>

Bit/Field	Name	Type	Reset	Description
3	P3	RW	1	<p>UART Module 3 Power Control</p> <p>The P_n bit encodings are not applicable if the corresponding bit in the RCGCUART, SCGCUART or DCGCUART register is clear.</p> <p>Value Description</p> <p>0 The UART module 3 is not powered and does not receive a clock. In this case, the module's state is not retained. This configuration provides the lowest power consumption state.</p> <p>1 The UART module 3 is powered, but does not receive a clock. In this case, the module is inactive.</p>
2	P2	RW	1	<p>UART Module 2 Power Control</p> <p>The P_n bit encodings are not applicable if the corresponding bit in the RCGCUART, SCGCUART or DCGCUART register is clear.</p> <p>Value Description</p> <p>0 The UART module 2 is not powered and does not receive a clock. In this case, the module's state is not retained. This configuration provides the lowest power consumption state.</p> <p>1 The UART module 2 is powered, but does not receive a clock. In this case, the module is inactive.</p>
1	P1	RW	1	<p>UART Module 1 Power Control</p> <p>The P_n bit encodings are not applicable if the corresponding bit in the RCGCUART, SCGCUART or DCGCUART register is clear.</p> <p>Value Description</p> <p>0 The UART module 1 is not powered and does not receive a clock. In this case, the module's state is not retained. This configuration provides the lowest power consumption state.</p> <p>1 The UART module 1 is powered, but does not receive a clock. In this case, the module is inactive.</p>
0	P0	RW	1	<p>UART Module 0 Power Control</p> <p>The P_n bit encodings are not applicable if the corresponding bit in the RCGCUART, SCGCUART or DCGCUART register is clear.</p> <p>Value Description</p> <p>0 The UART module 0 is not powered and does not receive a clock. In this case, the module's state is not retained. This configuration provides the lowest power consumption state.</p> <p>1 The UART module 0 is powered, but does not receive a clock. In this case, the module is inactive.</p>

Register 151: Synchronous Serial Interface Power Control (PCSSI), offset 0x91C

Important: The SSI module does not currently provide the ability to respond to the power down request. Setting a bit in this register has no effect on power consumption. This register is defined for future software compatibility.

The **PCSSI** register controls the power applied to the SSI module. The function of this bit depends on the current state of the device (Run, Sleep or Deep-Sleep mode) and value of the corresponding bits in the **RCGCSSI**, **SCGCSSI** and **DCGCSSI** registers. If the R_n , S_n , or D_n bit of the respective **RCGCSSI**, **SCGCSSI** and **DCGCSSI** registers is 1 and the device is in that mode, the module is powered and receives a clock irrespective of what the corresponding P_n bit in the **PCSSI** register is.

However, if the R_n , S_n , or D_n bit of the respective **RCGCSSI**, **SCGCSSI** and **DCGCSSI** registers is 0 and the device is in that mode, then the module behaves differently depending on the value of the corresponding P_n bit in the **PCSSI** register. In this case, when the P_n bit is clear the module is not powered and does not receive a clock. If the P_n bit is set, the module is powered but does not receive a clock. The table below details the differences.

Table 5-23. Module Power Control

R_n , S_n or D_n Value in Respective RCGCx , SCGCx , or DCGCx Register	P_n	Description
0	0	Module is not powered and does not receive a clock. In this case, the peripheral's state is not retained. This is the lowest power consumption state of any peripheral since it consumes no dynamic nor leakage current. Hardware should perform a peripheral reset if the active mode changes and the RCGCx , SCGCx , or DCGCx register is a 1 or the P_0 bit is changed to a 1. Software must re-initialize the peripheral when re-enabled due to the loss of state.
0	1	Module is powered, but does not receive a clock. In this case, the peripheral is inactive. This is the second-lowest power consumption of any peripheral since it consumes only leakage current.
1	X	Module is powered and receives a clock.

Synchronous Serial Interface Power Control (PCSSI)

Base 0x400F.E000
Offset 0x91C
Type RW, reset 0x0000.000F

	31	30	29	28	27	26	25	24	23	22	21	20	19	18	17	16	
	reserved																
Type	RO	RO	RO	RO	RO	RO	RO	RO	RO	RO	RO	RO	RO	RO	RO	RO	
Reset	0	0	0	0	0	0	0	0	0	0	0	0	0	0	0	0	
	15	14	13	12	11	10	9	8	7	6	5	4	3	2	1	0	
	reserved												P3	P2	P1	P0	
Type	RO	RO	RO	RO	RO	RO	RO	RO	RO	RO	RO	RO	RO	RW	RW	RW	RW
Reset	0	0	0	0	0	0	0	0	0	0	0	0	0	1	1	1	1

Bit/Field	Name	Type	Reset	Description				
31:4	reserved	RO	0	Software should not rely on the value of a reserved bit. To provide compatibility with future products, the value of a reserved bit should be preserved across a read-modify-write operation.				
3	P3	RW	1	<p>SSI Module 3 Power Control</p> <p>The P_n bit encodings are not applicable if the corresponding bit in the RCGCSSI, SCGCSSI or DCGCSSI register is clear.</p> <p>Value Description</p> <table border="1"> <tr> <td>0</td> <td>The SSI module 3 is not powered and does not receive a clock. In this case, the module's state is not retained. This configuration provides the lowest power consumption state.</td> </tr> <tr> <td>1</td> <td>The SSI module 3 is powered, but does not receive a clock. In this case, the module is inactive.</td> </tr> </table>	0	The SSI module 3 is not powered and does not receive a clock. In this case, the module's state is not retained. This configuration provides the lowest power consumption state.	1	The SSI module 3 is powered, but does not receive a clock. In this case, the module is inactive.
0	The SSI module 3 is not powered and does not receive a clock. In this case, the module's state is not retained. This configuration provides the lowest power consumption state.							
1	The SSI module 3 is powered, but does not receive a clock. In this case, the module is inactive.							
2	P2	RW	1	<p>SSI Module 2 Power Control</p> <p>The P_n bit encodings are not applicable if the corresponding bit in the RCGCSSI, SCGCSSI or DCGCSSI register is clear.</p> <p>Value Description</p> <table border="1"> <tr> <td>0</td> <td>The SSI module 2 is not powered and does not receive a clock. In this case, the module's state is not retained. This configuration provides the lowest power consumption state.</td> </tr> <tr> <td>1</td> <td>The SSI module 2 is powered, but does not receive a clock. In this case, the module is inactive.</td> </tr> </table>	0	The SSI module 2 is not powered and does not receive a clock. In this case, the module's state is not retained. This configuration provides the lowest power consumption state.	1	The SSI module 2 is powered, but does not receive a clock. In this case, the module is inactive.
0	The SSI module 2 is not powered and does not receive a clock. In this case, the module's state is not retained. This configuration provides the lowest power consumption state.							
1	The SSI module 2 is powered, but does not receive a clock. In this case, the module is inactive.							
1	P1	RW	1	<p>SSI Module 1 Power Control</p> <p>The P_n bit encodings are not applicable if the corresponding bit in the RCGCSSI, SCGCSSI or DCGCSSI register is clear.</p> <p>Value Description</p> <table border="1"> <tr> <td>0</td> <td>The SSI module 1 is not powered and does not receive a clock. In this case, the module's state is not retained. This configuration provides the lowest power consumption state.</td> </tr> <tr> <td>1</td> <td>The SSI module 1 is powered, but does not receive a clock. In this case, the module is inactive.</td> </tr> </table>	0	The SSI module 1 is not powered and does not receive a clock. In this case, the module's state is not retained. This configuration provides the lowest power consumption state.	1	The SSI module 1 is powered, but does not receive a clock. In this case, the module is inactive.
0	The SSI module 1 is not powered and does not receive a clock. In this case, the module's state is not retained. This configuration provides the lowest power consumption state.							
1	The SSI module 1 is powered, but does not receive a clock. In this case, the module is inactive.							
0	P0	RW	1	<p>SSI Module 0 Power Control</p> <p>The P_n bit encodings are not applicable if the corresponding bit in the RCGCSSI, SCGCSSI or DCGCSSI register is clear.</p> <p>Value Description</p> <table border="1"> <tr> <td>0</td> <td>The SSI module 0 is not powered and does not receive a clock. In this case, the module's state is not retained. This configuration provides the lowest power consumption state.</td> </tr> <tr> <td>1</td> <td>The SSI module 0 is powered, but does not receive a clock. In this case, the module is inactive.</td> </tr> </table>	0	The SSI module 0 is not powered and does not receive a clock. In this case, the module's state is not retained. This configuration provides the lowest power consumption state.	1	The SSI module 0 is powered, but does not receive a clock. In this case, the module is inactive.
0	The SSI module 0 is not powered and does not receive a clock. In this case, the module's state is not retained. This configuration provides the lowest power consumption state.							
1	The SSI module 0 is powered, but does not receive a clock. In this case, the module is inactive.							

Register 152: Inter-Integrated Circuit Power Control (PCI2C), offset 0x920

Important: The I2C module does not currently provide the ability to respond to the power down request. Setting a bit in this register has no effect on power consumption. This register is defined for future software compatibility.

The **PCI2C** register controls the power applied to the I2C module. The function of this bit depends on the current state of the device (Run, Sleep or Deep-Sleep mode) and value of the corresponding bits in the **RCGC12C**, **SCGC12C** and **DCGC12C** registers. If the R_n , S_n , or D_n bit of the respective **RCGC12C**, **SCGC12C** and **DCGC12C** registers is 1 and the device is in that mode, the module is powered and receives a clock irrespective of what the corresponding P_n bit in the **PCI2C** register is.

However, if the R_n , S_n , or D_n bit of the respective **RCGC12C**, **SCGC12C** and **DCGC12C** registers is 0 and the device is in that mode, then the module behaves differently depending on the value of the corresponding P_n bit in the **PCI2C** register. In this case, when the P_n bit is clear the module is not powered and does not receive a clock. If the P_n bit is set, the module is powered but does not receive a clock. The table below details the differences.

Table 5-24. Module Power Control

R _n , S _n or D _n Value in Respective RCGC _x , SCGC _x , or DCGC _x Register	P _n	Description
0	0	Module is not powered and does not receive a clock. In this case, the peripheral's state is not retained. This is the lowest power consumption state of any peripheral since it consumes no dynamic nor leakage current. Hardware should perform a peripheral reset if the active mode changes and the RCGC_x , SCGC_x , or DCGC_x register is a 1 or the P_0 bit is changed to a 1. Software must re-initialize the peripheral when re-enabled due to the loss of state.
0	1	Module is powered, but does not receive a clock. In this case, the peripheral is inactive. This is the second-lowest power consumption of any peripheral since it consumes only leakage current.
1	X	Module is powered and receives a clock.

Inter-Integrated Circuit Power Control (PCI2C)

Base 0x400F.E000
Offset 0x920
Type RW, reset 0x0000.03FF

	31	30	29	28	27	26	25	24	23	22	21	20	19	18	17	16
	reserved															
Type	RO	RO	RO	RO	RO	RO	RO	RO	RO	RO	RO	RO	RO	RO	RO	RO
Reset	0	0	0	0	0	0	0	0	0	0	0	0	0	0	0	0
	15	14	13	12	11	10	9	8	7	6	5	4	3	2	1	0
	reserved						P9	P8	P7	P6	P5	P4	P3	P2	P1	P0
Type	RO	RO	RO	RO	RO	RO	RW	RW	RW	RW	RW	RW	RW	RW	RW	RW
Reset	0	0	0	0	0	0	1	1	1	1	1	1	1	1	1	1

Bit/Field	Name	Type	Reset	Description
31:10	reserved	RO	0	Software should not rely on the value of a reserved bit. To provide compatibility with future products, the value of a reserved bit should be preserved across a read-modify-write operation.

Bit/Field	Name	Type	Reset	Description
9	P9	RW	1	<p>I²C Module 9 Power Control</p> <p>The P_n bit encodings are not applicable if the corresponding bit in the RCGCI2C, SCGCI2C or DCGCI2C register is clear.</p> <p>Value Description</p> <p>0 The I²C module 9 is not powered and does not receive a clock. In this case, the module's state is not retained. This configuration provides the lowest power consumption state.</p> <p>1 The I²C module 9 is powered, but does not receive a clock. In this case, the module is inactive.</p>
8	P8	RW	1	<p>I²C Module 8 Power Control</p> <p>The P_n bit encodings are not applicable if the corresponding bit in the RCGCI2C, SCGCI2C or DCGCI2C register is clear.</p> <p>Value Description</p> <p>0 The I²C module 8 is not powered and does not receive a clock. In this case, the module's state is not retained. This configuration provides the lowest power consumption state.</p> <p>1 The I²C module 8 is powered, but does not receive a clock. In this case, the module is inactive.</p>
7	P7	RW	1	<p>I²C Module 7 Power Control</p> <p>The P_n bit encodings are not applicable if the corresponding bit in the RCGCI2C, SCGCI2C or DCGCI2C register is clear.</p> <p>Value Description</p> <p>0 The I²C module 7 is not powered and does not receive a clock. In this case, the module's state is not retained. This configuration provides the lowest power consumption state.</p> <p>1 The I²C module 7 is powered, but does not receive a clock. In this case, the module is inactive.</p>
6	P6	RW	1	<p>I²C Module 6 Power Control</p> <p>The P_n bit encodings are not applicable if the corresponding bit in the RCGCI2C, SCGCI2C or DCGCI2C register is clear.</p> <p>Value Description</p> <p>0 The I²C module 6 is not powered and does not receive a clock. In this case, the module's state is not retained. This configuration provides the lowest power consumption state.</p> <p>1 The I²C module 6 is powered, but does not receive a clock. In this case, the module is inactive.</p>

Bit/Field	Name	Type	Reset	Description
5	P5	RW	1	<p>I²C Module 5 Power Control</p> <p>The P_n bit encodings are not applicable if the corresponding bit in the RCGCI2C, SCGCI2C or DCGCI2C register is clear.</p> <p>Value Description</p> <p>0 The I²C module 5 is not powered and does not receive a clock. In this case, the module's state is not retained. This configuration provides the lowest power consumption state.</p> <p>1 The I²C module 5 is powered, but does not receive a clock. In this case, the module is inactive.</p>
4	P4	RW	1	<p>I²C Module 4 Power Control</p> <p>The P_n bit encodings are not applicable if the corresponding bit in the RCGCI2C, SCGCI2C or DCGCI2C register is clear.</p> <p>Value Description</p> <p>0 The I²C module 4 is not powered and does not receive a clock. In this case, the module's state is not retained. This configuration provides the lowest power consumption state.</p> <p>1 The I²C module 4 is powered, but does not receive a clock. In this case, the module is inactive.</p>
3	P3	RW	1	<p>I²C Module 3 Power Control</p> <p>The P_n bit encodings are not applicable if the corresponding bit in the RCGCI2C, SCGCI2C or DCGCI2C register is clear.</p> <p>Value Description</p> <p>0 The I²C module 3 is not powered and does not receive a clock. In this case, the module's state is not retained. This configuration provides the lowest power consumption state.</p> <p>1 The I²C module 3 is powered, but does not receive a clock. In this case, the module is inactive.</p>
2	P2	RW	1	<p>I²C Module 2 Power Control</p> <p>The P_n bit encodings are not applicable if the corresponding bit in the RCGCI2C, SCGCI2C or DCGCI2C register is clear.</p> <p>Value Description</p> <p>0 The I²C module 2 is not powered and does not receive a clock. In this case, the module's state is not retained. This configuration provides the lowest power consumption state.</p> <p>1 The I²C module 2 is powered, but does not receive a clock. In this case, the module is inactive.</p>

Bit/Field	Name	Type	Reset	Description
1	P1	RW	1	<p>I²C Module 1 Power Control</p> <p>The P_n bit encodings are not applicable if the corresponding bit in the RCGCI2C, SCGCI2C or DCGCI2C register is clear.</p> <p>Value Description</p> <p>0 The I²C module 1 is not powered and does not receive a clock. In this case, the module's state is not retained. This configuration provides the lowest power consumption state.</p> <p>1 The I²C module 1 is powered, but does not receive a clock. In this case, the module is inactive.</p>
0	P0	RW	1	<p>I²C Module 0 Power Control</p> <p>The P_n bit encodings are not applicable if the corresponding bit in the RCGCI2C, SCGCI2C or DCGCI2C register is clear.</p> <p>Value Description</p> <p>0 The I²C module 0 is not powered and does not receive a clock. In this case, the module's state is not retained. This configuration provides the lowest power consumption state.</p> <p>1 The I²C module 0 is powered, but does not receive a clock. In this case, the module is inactive.</p>

Register 153: Universal Serial Bus Power Control (PCUSB), offset 0x928

The **PCUSB** register controls the power applied to the USB module. The function of this bit depends on the current state of the device (Run, Sleep or Deep-Sleep mode) and value of the corresponding bits in the **RCGCUSB**, **SCGCUSB** and **DCGCUSB** registers. If the R_n , S_n , or D_n bit of the respective **RCGCUSB**, **SCGCUSB** and **DCGCUSB** registers is 1 and the device is in that mode, the module is powered and receives a clock irrespective of what the corresponding P_n bit in the **PCUSB** register is.

However, if the R_n , S_n , or D_n bit of the respective **RCGCUSB**, **SCGCUSB** and **DCGCUSB** registers is 0 and the device is in that mode, then the module behaves differently depending on the value of the corresponding P_n bit in the **PCUSB** register. In this case, when the P_n bit is clear the module is not powered and does not receive a clock. If the P_n bit is set, the module is powered but does not receive a clock. The table below details the differences.

Table 5-25. Module Power Control

R_n , S_n or D_n Value in Respective RCGCx , SCGCx , or DCGCx Register	P_n	Description
0	0	Module is not powered and does not receive a clock. In this case, the peripheral's state is not retained. This is the lowest power consumption state of any peripheral since it consumes no dynamic nor leakage current. Hardware should perform a peripheral reset if the active mode changes and the RCGCx , SCGCx , or DCGCx register is a 1 or the P_0 bit is changed to a 1. Software must re-initialize the peripheral when re-enabled due to the loss of state.
0	1	Module is powered, but does not receive a clock. In this case, the peripheral is inactive. This is the second-lowest power consumption of any peripheral since it consumes only leakage current.
1	X	Module is powered and receives a clock.

Universal Serial Bus Power Control (PCUSB)

Base 0x400F.E000
Offset 0x928
Type RW, reset 0x0000.0001

	31	30	29	28	27	26	25	24	23	22	21	20	19	18	17	16	
	reserved																
Type	RO	RO	RO	RO	RO	RO	RO	RO	RO	RO	RO	RO	RO	RO	RO	RO	
Reset	0	0	0	0	0	0	0	0	0	0	0	0	0	0	0	0	
	15	14	13	12	11	10	9	8	7	6	5	4	3	2	1	0	
	reserved															P0	
Type	RO	RO	RO	RO	RO	RO	RO	RO	RO	RO	RO	RO	RO	RO	RO	RO	RW
Reset	0	0	0	0	0	0	0	0	0	0	0	0	0	0	0	0	1

Bit/Field	Name	Type	Reset	Description
31:1	reserved	RO	0	Software should not rely on the value of a reserved bit. To provide compatibility with future products, the value of a reserved bit should be preserved across a read-modify-write operation.

Bit/Field	Name	Type	Reset	Description
0	P0	RW	1	<p>USB Module Power Control</p> <p>The P_n bit encodings are not applicable if the corresponding bit in the RCGCUSB, SCGCUSB or DCGCUSB register is clear.</p> <p>Value Description</p> <p>0 The USB module is not powered and does not receive a clock. In this case, the module's state is not retained. This configuration provides the lowest power consumption state.</p> <p>1 The USB module is powered, but does not receive a clock. In this case, the module is inactive.</p>

Register 154: Ethernet PHY Power Control (PCEPHY), offset 0x930

The **PCEPHY** register controls the power applied to the EEPROM module. The function of this bit depends on the current state of the device (Run, Sleep or Deep-Sleep mode) and value of the corresponding bits in the **RCGCEPHY**, **SCGCEPHY** and **DCGCEPHY** registers. If the R_n , S_n , or D_n bit of the respective **RCGCEPHY**, **SCGCEPHY** and **DCGCEPHY** registers is 1 and the device is in that mode, the module is powered and receives a clock irrespective of what the corresponding P_n bit in the **PCEPHY** register is.

However, if the R_n , S_n , or D_n bit of the respective **RCGCEPHY**, **SCGCEPHY** and **DCGCEPHY** registers is 0 and the device is in that mode, then the module behaves differently depending on the value of the corresponding P_n bit in the **PCEPHY** register. In this case, when the P_n bit is clear the module is not powered and does not receive a clock. If the P_n bit is set, the module is powered but does not receive a clock. The table below details the differences.

Table 5-26. Module Power Control

R_n , S_n or D_n Value in Respective RCGCx , SCGCx , or DCGCx Register	P_n	Description
0	0	Module is not powered and does not receive a clock. In this case, the peripheral's state is not retained. This is the lowest power consumption state of any peripheral since it consumes no dynamic nor leakage current. Hardware should perform a peripheral reset if the active mode changes and the RCGCx , SCGCx , or DCGCx register is a 1 or the P_0 bit is changed to a 1. Software must re-initialize the peripheral when re-enabled due to the loss of state.
0	1	Module is powered, but does not receive a clock. In this case, the peripheral is inactive. This is the second-lowest power consumption of any peripheral since it consumes only leakage current.
1	X	Module is powered and receives a clock.

Note: The Ethernet PHY module is not powered up at reset to prevent an automatic negotiation on power-up. To properly initialize the PHY, first inhibit the PHY from running on power up by setting the **PHYHOLD** bit in the **Ethernet Peripheral Configuration (EMACPC)** register and then set the P_0 bit in the **PCEPHY** register. Once it is determined that the PHY is ready (by polling the R_0 bit in the **Peripheral Ready (PREPHY)** register), the PHY can be programmed with its appropriate values.

Note: If the MOSC is chosen as the clock to the Ethernet PHY then software has to enable the MOSC before enabling the Ethernet PHY by setting the P_0 bit in the **PCEPHY**.

Ethernet PHY Power Control (PCEPHY)

Base 0x400F.E000
Offset 0x930
Type RW, reset 0x0000.0000

	31	30	29	28	27	26	25	24	23	22	21	20	19	18	17	16
	reserved															
Type	RO	RO	RO	RO	RO	RO	RO	RO	RO	RO	RO	RO	RO	RO	RO	RO
Reset	0	0	0	0	0	0	0	0	0	0	0	0	0	0	0	0
	15	14	13	12	11	10	9	8	7	6	5	4	3	2	1	0
	reserved															P_0
Type	RO	RO	RO	RO	RO	RO	RO	RO	RO	RO	RO	RO	RO	RO	RO	RW
Reset	0	0	0	0	0	0	0	0	0	0	0	0	0	0	0	0

Bit/Field	Name	Type	Reset	Description
31:1	reserved	RO	0	Software should not rely on the value of a reserved bit. To provide compatibility with future products, the value of a reserved bit should be preserved across a read-modify-write operation.
0	P0	RW	0	Ethernet PHY Module Power Control The P _n bit encodings are not applicable if the corresponding bit in the RCGCEPHY , SCGCEPHY or DCGCEPHY register is clear. Value Description 0 The EPHY module is not powered and does not receive a clock. In this case, the module's state is not retained. This configuration provides the lowest power consumption state. 1 The EPHY module is powered, but does not receive a clock. In this case, the module is inactive.

Register 155: Controller Area Network Power Control (PCCAN), offset 0x934

The **PCCAN** register controls the power applied to the CAN module. The function of this bit depends on the current state of the device (Run, Sleep or Deep-Sleep mode) and value of the corresponding bits in the **RCGCCAN**, **SCGCCAN** and **DCGCCAN** registers. If the R_n , S_n , or D_n bit of the respective **RCGCCAN**, **SCGCCAN** and **DCGCCAN** registers is 1 and the device is in that mode, the module is powered and receives a clock irrespective of what the corresponding P_n bit in the **PCCAN** register is.

However, if the R_n , S_n , or D_n bit of the respective **RCGCCAN**, **SCGCCAN** and **DCGCCAN** registers is 0 and the device is in that mode, then the module behaves differently depending on the value of the corresponding P_n bit in the **PCCAN** register. In this case, when the P_n bit is clear the module is not powered and does not receive a clock. If the P_n bit is set, the module is powered but does not receive a clock. The table below details the differences.

Table 5-27. Module Power Control

R_n , S_n or D_n Value in Respective RCGCx , SCGCx , or DCGCx Register	P_n	Description
0	0	Module is not powered and does not receive a clock. In this case, the peripheral's state is not retained. This is the lowest power consumption state of any peripheral since it consumes no dynamic nor leakage current. Hardware should perform a peripheral reset if the active mode changes and the RCGCx , SCGCx , or DCGCx register is a 1 or the P_0 bit is changed to a 1. Software must re-initialize the peripheral when re-enabled due to the loss of state.
0	1	Module is powered, but does not receive a clock. In this case, the peripheral is inactive. This is the second-lowest power consumption of any peripheral since it consumes only leakage current.
1	X	Module is powered and receives a clock.

Controller Area Network Power Control (PCCAN)

Base 0x400F.E000
Offset 0x934
Type RW, reset 0x0000.0003

	31	30	29	28	27	26	25	24	23	22	21	20	19	18	17	16	
	reserved																
Type	RO	RO	RO	RO	RO	RO	RO	RO	RO	RO	RO	RO	RO	RO	RO	RO	
Reset	0	0	0	0	0	0	0	0	0	0	0	0	0	0	0	0	
	15	14	13	12	11	10	9	8	7	6	5	4	3	2	1	0	
	reserved															P1	P0
Type	RO	RO	RO	RO	RO	RO	RO	RO	RO	RO	RO	RO	RO	RO	RO	RW	RW
Reset	0	0	0	0	0	0	0	0	0	0	0	0	0	0	1	1	

Bit/Field	Name	Type	Reset	Description
31:2	reserved	RO	0	Software should not rely on the value of a reserved bit. To provide compatibility with future products, the value of a reserved bit should be preserved across a read-modify-write operation.

Bit/Field	Name	Type	Reset	Description
1	P1	RW	1	<p>CAN Module 1 Power Control</p> <p>The P_n bit encodings are not applicable if the corresponding bit in the RCGCCAN, SCGCCAN or DCGCCAN register is clear.</p> <p>Value Description</p> <p>0 The CAN module 1 is not powered and does not receive a clock. In this case, the module's state is not retained. This configuration provides the lowest power consumption state.</p> <p>1 The CAN module 1 is powered, but does not receive a clock. In this case, the module is inactive.</p>
0	P0	RW	1	<p>CAN Module 0 Power Control</p> <p>The P_n bit encodings are not applicable if the corresponding bit in the RCGCCAN, SCGCCAN or DCGCCAN register is clear.</p> <p>Value Description</p> <p>0 The CAN module 0 is not powered and does not receive a clock. In this case, the module's state is not retained. This configuration provides the lowest power consumption state.</p> <p>1 The CAN module 0 is powered, but does not receive a clock. In this case, the module is inactive.</p>

Register 156: Analog-to-Digital Converter Power Control (PCADC), offset 0x938

Important: The ADC module does not currently provide the ability to respond to the power down request. Setting a bit in this register has no effect on power consumption. This register is defined for future software compatibility.

The **PCADC** register controls the power applied to the ADC module. The function of this bit depends on the current state of the device (Run, Sleep or Deep-Sleep mode) and value of the corresponding bits in the **RCGCADC**, **SCGCADC** and **DCGCADC** registers. If the R_n , S_n , or D_n bit of the respective **RCGCADC**, **SCGCADC** and **DCGCADC** registers is 1 and the device is in that mode, the module is powered and receives a clock irrespective of what the corresponding P_n bit in the **PCADC** register is.

However, if the R_n , S_n , or D_n bit of the respective **RCGCADC**, **SCGCADC** and **DCGCADC** registers is 0 and the device is in that mode, then the module behaves differently depending on the value of the corresponding P_n bit in the **PCADC** register. In this case, when the P_n bit is clear the module is not powered and does not receive a clock. If the P_n bit is set, the module is powered but does not receive a clock. The table below details the differences.

Table 5-28. Module Power Control

R _n , S _n or D _n Value in Respective RCGC _x , SCGC _x , or DCGC _x Register	P _n	Description
0	0	Module is not powered and does not receive a clock. In this case, the peripheral's state is not retained. This is the lowest power consumption state of any peripheral since it consumes no dynamic nor leakage current. Hardware should perform a peripheral reset if the active mode changes and the RCGC_x , SCGC_x , or DCGC_x register is a 1 or the P0 bit is changed to a 1. Software must re-initialize the peripheral when re-enabled due to the loss of state.
0	1	Module is powered, but does not receive a clock. In this case, the peripheral is inactive. This is the second-lowest power consumption of any peripheral since it consumes only leakage current.
1	X	Module is powered and receives a clock.

Analog-to-Digital Converter Power Control (PCADC)

Base 0x400F.E000

Offset 0x938

Type RW, reset 0x0000.0003

	31	30	29	28	27	26	25	24	23	22	21	20	19	18	17	16	
	reserved																
Type	RO	RO	RO	RO	RO	RO	RO	RO	RO	RO	RO	RO	RO	RO	RO	RO	
Reset	0	0	0	0	0	0	0	0	0	0	0	0	0	0	0	0	
	15	14	13	12	11	10	9	8	7	6	5	4	3	2	1	0	
	reserved															P1	P0
Type	RO	RO	RO	RO	RO	RO	RO	RO	RO	RO	RO	RO	RO	RO	RO	RW	RW
Reset	0	0	0	0	0	0	0	0	0	0	0	0	0	0	0	1	1

Bit/Field	Name	Type	Reset	Description
31:2	reserved	RO	0	Software should not rely on the value of a reserved bit. To provide compatibility with future products, the value of a reserved bit should be preserved across a read-modify-write operation.
1	P1	RW	1	<p>ADC Module 1 Power Control</p> <p>The P_n bit encodings are not applicable if the corresponding bit in the RCGCADC, SCGCADC or DCGCADC register is clear.</p> <p>Value Description</p> <p>0 The ADC module 1 is not powered and does not receive a clock. In this case, the module's state is not retained. This configuration provides the lowest power consumption state.</p> <p>1 The ADC module 1 is powered, but does not receive a clock. In this case, the module is inactive.</p>
0	P0	RW	1	<p>ADC Module 0 Power Control</p> <p>The P_n bit encodings are not applicable if the corresponding bit in the RCGCADC, SCGCADC or DCGCADC register is clear.</p> <p>Value Description</p> <p>0 The ADC module 0 is not powered and does not receive a clock. In this case, the module's state is not retained. This configuration provides the lowest power consumption state.</p> <p>1 The ADC module 0 is powered, but does not receive a clock. In this case, the module is inactive.</p>

Register 157: Analog Comparator Power Control (PCACMP), offset 0x93C

Important: The ACMP module does not currently provide the ability to respond to the power down request. Setting a bit in this register has no effect on power consumption. This register is defined for future software compatibility.

The **PCACMP** register controls the power applied to the ACMP module. The function of this bit depends on the current state of the device (Run, Sleep or Deep-Sleep mode) and value of the corresponding bits in the **RCGCACMP**, **SCGCACMP** and **DCGCACMP** registers. If the R_n , S_n , or D_n bit of the respective **RCGCACMP**, **SCGCACMP** and **DCGCACMP** registers is 1 and the device is in that mode, the module is powered and receives a clock irrespective of what the corresponding P_n bit in the **PCACMP** register is.

However, if the R_n , S_n , or D_n bit of the respective **RCGCACMP**, **SCGCACMP** and **DCGCACMP** registers is 0 and the device is in that mode, then the module behaves differently depending on the value of the corresponding P_n bit in the **PCACMP** register. In this case, when the P_n bit is clear the module is not powered and does not receive a clock. If the P_n bit is set, the module is powered but does not receive a clock. The table below details the differences.

Table 5-29. Module Power Control

R_n , S_n or D_n Value in Respective RCGCx , SCGCx , or DCGCx Register	P_n	Description
0	0	Module is not powered and does not receive a clock. In this case, the peripheral's state is not retained. This is the lowest power consumption state of any peripheral since it consumes no dynamic nor leakage current. Hardware should perform a peripheral reset if the active mode changes and the RCGCx , SCGCx , or DCGCx register is a 1 or the P_0 bit is changed to a 1. Software must re-initialize the peripheral when re-enabled due to the loss of state.
0	1	Module is powered, but does not receive a clock. In this case, the peripheral is inactive. This is the second-lowest power consumption of any peripheral since it consumes only leakage current.
1	X	Module is powered and receives a clock.

Analog Comparator Power Control (PCACMP)

Base 0x400F.E000
Offset 0x93C
Type RW, reset 0x0000.0001

	31	30	29	28	27	26	25	24	23	22	21	20	19	18	17	16
	reserved															
Type	RO	RO	RO	RO	RO	RO	RO	RO	RO	RO	RO	RO	RO	RO	RO	RO
Reset	0	0	0	0	0	0	0	0	0	0	0	0	0	0	0	0
	15	14	13	12	11	10	9	8	7	6	5	4	3	2	1	0
	reserved															P0
Type	RO	RO	RO	RO	RO	RO	RO	RO	RO	RO	RO	RO	RO	RO	RO	RW
Reset	0	0	0	0	0	0	0	0	0	0	0	0	0	0	0	1

Bit/Field	Name	Type	Reset	Description
31:1	reserved	RO	0	Software should not rely on the value of a reserved bit. To provide compatibility with future products, the value of a reserved bit should be preserved across a read-modify-write operation.

Bit/Field	Name	Type	Reset	Description
0	P0	RW	1	<p>Analog Comparator Module 0 Power Control</p> <p>The Pn bit encodings are not applicable if the corresponding bit in the RCGCACMP, SCGCACMP or DCGCACMP register is clear.</p> <p>Value Description</p> <p>0 The Analog Comparator module is not powered and does not receive a clock. In this case, the module's state is not retained. This configuration provides the lowest power consumption state.</p> <p>1 The Analog Comparator module is powered, but does not receive a clock. In this case, the module is inactive.</p>

Register 158: Pulse Width Modulator Power Control (PCPWM), offset 0x940

Important: The PWM module does not currently provide the ability to respond to the power down request. Setting a bit in this register has no effect on power consumption. This register is defined for future software compatibility.

The **PCPWM** register controls the power applied to the PWM module. The function of this bit depends on the current state of the device (Run, Sleep or Deep-Sleep mode) and value of the corresponding bits in the **RCGCPWM**, **SCGCPWM** and **DCGCPWM** registers. If the R_n , S_n , or D_n bit of the respective **RCGCPWM**, **SCGCPWM** and **DCGCPWM** registers is 1 and the device is in that mode, the module is powered and receives a clock irrespective of what the corresponding P_n bit in the **PCPWM** register is.

However, if the R_n , S_n , or D_n bit of the respective **RCGCPWM**, **SCGCPWM** and **DCGCPWM** registers is 0 and the device is in that mode, then the module behaves differently depending on the value of the corresponding P_n bit in the **PCPWM** register. In this case, when the P_n bit is clear the module is not powered and does not receive a clock. If the P_n bit is set, the module is powered but does not receive a clock. The table below details the differences.

Table 5-30. Module Power Control

Rn, Sn or Dn Value in Respective RCGCx, SCGCx, or DCGCx Register	Pn	Description
0	0	Module is not powered and does not receive a clock. In this case, the peripheral's state is not retained. This is the lowest power consumption state of any peripheral since it consumes no dynamic nor leakage current. Hardware should perform a peripheral reset if the active mode changes and the RCGCx , SCGCx , or DCGCx register is a 1 or the P_0 bit is changed to a 1. Software must re-initialize the peripheral when re-enabled due to the loss of state.
0	1	Module is powered, but does not receive a clock. In this case, the peripheral is inactive. This is the second-lowest power consumption of any peripheral since it consumes only leakage current.
1	X	Module is powered and receives a clock.

Pulse Width Modulator Power Control (PCPWM)

Base 0x400F.E000
Offset 0x940
Type RW, reset 0x0000.0001

	31	30	29	28	27	26	25	24	23	22	21	20	19	18	17	16
	reserved															
Type	RO	RO	RO	RO	RO	RO	RO	RO	RO	RO	RO	RO	RO	RO	RO	RO
Reset	0	0	0	0	0	0	0	0	0	0	0	0	0	0	0	0
	15	14	13	12	11	10	9	8	7	6	5	4	3	2	1	0
	reserved															P0
Type	RO	RO	RO	RO	RO	RO	RO	RO	RO	RO	RO	RO	RO	RO	RO	RW
Reset	0	0	0	0	0	0	0	0	0	0	0	0	0	0	0	1

Bit/Field	Name	Type	Reset	Description
31:1	reserved	RO	0	Software should not rely on the value of a reserved bit. To provide compatibility with future products, the value of a reserved bit should be preserved across a read-modify-write operation.

Bit/Field	Name	Type	Reset	Description
0	P0	RW	1	<p>PWM Module 0 Power Control</p> <p>The P_n bit encodings are not applicable if the corresponding bit in the RCGCPWM, SCGCPWM or DCGCPWM register is clear.</p> <p>Value Description</p> <p>0 The PWM module 0 is not powered and does not receive a clock. In this case, the module's state is not retained. This configuration provides the lowest power consumption state.</p> <p>1 The PWM module 0 is powered, but does not receive a clock. In this case, the module is inactive.</p>

Register 159: Quadrature Encoder Interface Power Control (PCQEI), offset 0x944

Important: The QEI module does not currently provide the ability to respond to the power down request. Setting a bit in this register has no effect on power consumption. This register is defined for future software compatibility.

The **PCQEI** register controls the power applied to the QEI module. The function of this bit depends on the current state of the device (Run, Sleep or Deep-Sleep mode) and value of the corresponding bits in the **RCGCQEI**, **SCGCQEI** and **DCGCQEI** registers. If the R_n , S_n , or D_n bit of the respective **RCGCQEI**, **SCGCQEI** and **DCGCQEI** registers is 1 and the device is in that mode, the module is powered and receives a clock irrespective of what the corresponding P_n bit in the **PCQEI** register is.

However, if the R_n , S_n , or D_n bit of the respective **RCGCQEI**, **SCGCQEI** and **DCGCQEI** registers is 0 and the device is in that mode, then the module behaves differently depending on the value of the corresponding P_n bit in the **PCQEI** register. In this case, when the P_n bit is clear the module is not powered and does not receive a clock. If the P_n bit is set, the module is powered but does not receive a clock. The table below details the differences.

Table 5-31. Module Power Control

R _n , S _n or D _n Value in Respective RCGCx, SCGCx, or DCGCx Register	P _n	Description
0	0	Module is not powered and does not receive a clock. In this case, the peripheral's state is not retained. This is the lowest power consumption state of any peripheral since it consumes no dynamic nor leakage current. Hardware should perform a peripheral reset if the active mode changes and the RCGCx , SCGCx , or DCGCx register is a 1 or the P0 bit is changed to a 1. Software must re-initialize the peripheral when re-enabled due to the loss of state.
0	1	Module is powered, but does not receive a clock. In this case, the peripheral is inactive. This is the second-lowest power consumption of any peripheral since it consumes only leakage current.
1	X	Module is powered and receives a clock.

Quadrature Encoder Interface Power Control (PCQEI)

Base 0x400F.E000
Offset 0x944
Type RW, reset 0x0000.0001

	31	30	29	28	27	26	25	24	23	22	21	20	19	18	17	16
	reserved															
Type	RO	RO	RO	RO	RO	RO	RO	RO	RO	RO	RO	RO	RO	RO	RO	RO
Reset	0	0	0	0	0	0	0	0	0	0	0	0	0	0	0	0
	15	14	13	12	11	10	9	8	7	6	5	4	3	2	1	0
	reserved															P0
Type	RO	RO	RO	RO	RO	RO	RO	RO	RO	RO	RO	RO	RO	RO	RO	RW
Reset	0	0	0	0	0	0	0	0	0	0	0	0	0	0	0	1

Bit/Field	Name	Type	Reset	Description
31:1	reserved	RO	0	Software should not rely on the value of a reserved bit. To provide compatibility with future products, the value of a reserved bit should be preserved across a read-modify-write operation.
0	P0	RW	1	QEI Module 0 Power Control The P _n bit encodings are not applicable if the corresponding bit in the RCGCQE1 , SCGCQE1 or DCGCQE1 register is clear. Value Description 0 QEI module 0 is not powered and does not receive a clock. In this case, the module's state is not retained. This configuration provides the lowest power consumption state. 1 QEI module 0 is powered, but does not receive a clock. In this case, the module is inactive.

Register 160: EEPROM Power Control (PCEEPROM), offset 0x958

Important: The EEPROM module does not currently provide the ability to respond to the power down request. Setting a bit in this register has no effect on power consumption. This register is defined for future software compatibility.

The **PCEEPROM** register controls the power applied to the EEPROM module. The function of this bit depends on the current state of the device (Run, Sleep or Deep-Sleep mode) and value of the corresponding bits in the **RCGCEEPROM**, **SCGCEEPROM** and **DCGCEEPROM** registers. If the R_n , S_n , or D_n bit of the respective **RCGCEEPROM**, **SCGCEEPROM** and **DCGCEEPROM** registers is 1 and the device is in that mode, the module is powered and receives a clock irrespective of what the corresponding P_n bit in the **PCEEPROM** register is.

However, if the R_n , S_n , or D_n bit of the respective **RCGCEEPROM**, **SCGCEEPROM** and **DCGCEEPROM** registers is 0 and the device is in that mode, then the module behaves differently depending on the value of the corresponding P_n bit in the **PCEEPROM** register. In this case, when the P_n bit is clear the module is not powered and does not receive a clock. If the P_n bit is set, the module is powered but does not receive a clock. The table below details the differences.

Table 5-32. Module Power Control

R _n , S _n or D _n Value in Respective RCGCx, SCGCx, or DCGCx Register	P _n	Description
0	0	Module is not powered and does not receive a clock. In this case, the peripheral's state is not retained. This is the lowest power consumption state of any peripheral since it consumes no dynamic nor leakage current. Hardware should perform a peripheral reset if the active mode changes and the RCGCx , SCGCx , or DCGCx register is a 1 or the P_0 bit is changed to a 1. Software must re-initialize the peripheral when re-enabled due to the loss of state.
0	1	Module is powered, but does not receive a clock. In this case, the peripheral is inactive. This is the second-lowest power consumption of any peripheral since it consumes only leakage current.
1	X	Module is powered and receives a clock.

EEPROM Power Control (PCEEPROM)

Base 0x400F.E000
Offset 0x958
Type RW, reset 0x0000.0001

	31	30	29	28	27	26	25	24	23	22	21	20	19	18	17	16
	reserved															
Type	RO	RO	RO	RO	RO	RO	RO	RO	RO	RO	RO	RO	RO	RO	RO	RO
Reset	0	0	0	0	0	0	0	0	0	0	0	0	0	0	0	0
	15	14	13	12	11	10	9	8	7	6	5	4	3	2	1	0
	reserved															P0
Type	RO	RO	RO	RO	RO	RO	RO	RO	RO	RO	RO	RO	RO	RO	RO	RW
Reset	0	0	0	0	0	0	0	0	0	0	0	0	0	0	0	1

Bit/Field	Name	Type	Reset	Description
31:1	reserved	RO	0	Software should not rely on the value of a reserved bit. To provide compatibility with future products, the value of a reserved bit should be preserved across a read-modify-write operation.

Bit/Field	Name	Type	Reset	Description
0	P0	RW	1	EEPROM Module 0 Power Control The P_n bit encodings are not applicable if the corresponding bit in the RCGCEEPROM , SCGCEEPROM or DCGCEEPROM register is clear. Value Description 0 The EEPROM module is not powered and does not receive a clock. In this case, the module's state is not retained. This configuration provides the lowest power consumption state. 1 The EEPROM module is powered, but does not receive a clock. In this case, the module is inactive.

Register 161: CRC and Cryptographic Modules Power Control (PCCCM), offset 0x974

The **PCCCM** register controls the power applied to the CRC and AES, DES, and SHA/MD5 modules. The function of this bit depends on the current state of the device (Run, Sleep or Deep-Sleep mode) and value of the corresponding bits in the **RCGCCM**, **SCGCCM** and **DCGCCM** registers. If the R_n , S_n , or D_n bit of the respective **RCGCCM**, **SCGCCM** and **DCGCCM** registers is 1 and the device is in that mode, the module is powered and receives a clock irrespective of what the corresponding P_n bit in the **PCCCM** register is.

However, if the R_n , S_n , or D_n bit of the respective **RCGCCM**, **SCGCCM** and **DCGCCM** registers is 0 and the device is in that mode, then the module behaves differently depending on the value of the corresponding P_n bit in the **PCCCM** register. In this case, when the P_n bit is clear the module is not powered and does not receive a clock. If the P_n bit is set, the module is powered but does not receive a clock. The table below details the differences.

Table 5-33. Module Power Control

R _n , S _n or D _n Value in Respective RCGC _x , SCGC _x , or DCGC _x Register	P _n	Description
0	0	Module is not powered and does not receive a clock. In this case, the peripheral's state is not retained. This is the lowest power consumption state of any peripheral since it consumes no dynamic nor leakage current. Hardware should perform a peripheral reset if the active mode changes and the RCGC_x , SCGC_x , or DCGC_x register is a 1 or the P0 bit is changed to a 1. Software must re-initialize the peripheral when re-enabled due to the loss of state.
0	1	Module is powered, but does not receive a clock. In this case, the peripheral is inactive. This is the second-lowest power consumption of any peripheral since it consumes only leakage current.
1	X	Module is powered and receives a clock.

CRC and Cryptographic Modules Power Control (PCCCM)

Base 0x400F.E000
Offset 0x974
Type RW, reset 0x0000.0001

	31	30	29	28	27	26	25	24	23	22	21	20	19	18	17	16
	reserved															
Type	RO	RO	RO	RO	RO	RO	RO	RO	RO	RO	RO	RO	RO	RO	RO	RO
Reset	0	0	0	0	0	0	0	0	0	0	0	0	0	0	0	0
	15	14	13	12	11	10	9	8	7	6	5	4	3	2	1	0
	reserved															P0
Type	RO	RO	RO	RO	RO	RO	RO	RO	RO	RO	RO	RO	RO	RO	RO	RW
Reset	0	0	0	0	0	0	0	0	0	0	0	0	0	0	0	1

Bit/Field	Name	Type	Reset	Description
31:1	reserved	RO	0	Software should not rely on the value of a reserved bit. To provide compatibility with future products, the value of a reserved bit should be preserved across a read-modify-write operation.

Bit/Field	Name	Type	Reset	Description
0	P0	RW	1	<p>CRC and Cryptographic Modules Power Control</p> <p>The P_n bit encodings are not applicable if the corresponding bit in the RCGCCCM, SCGCCCM or DCGCCCM register is clear.</p> <p>Value Description</p> <p>0 The CRC, AES, DES, and SHA/MD5 modules are not powered and do not receive a clock. In this case, the module's state is not retained.</p> <p>This configuration provides the lowest power consumption state.</p> <p>1 The CRC, AES, DES, and SHA/MD5 modules are powered, but do not receive a clock. In this case, the modules are inactive.</p>

Register 162: Ethernet MAC Power Control (PCEMAC), offset 0x99C

The **PCEMAC** register controls the power applied to the EMAC module. The function of this bit depends on the current state of the device (Run, Sleep or Deep-Sleep mode) and value of the corresponding bits in the **RCGCEMAC**, **SCGCEMAC** and **DCGCEMAC** registers. If the R_n , S_n , or D_n bit of the respective **RCGCEMAC**, **SCGCEMAC** and **DCGCEMAC** registers is 1 and the device is in that mode, the module is powered and receives a clock irrespective of what the corresponding P_n bit in the **PCEMAC** register is.

However, if the R_n , S_n , or D_n bit of the respective **RCGCEMAC**, **SCGCEMAC** and **DCGCEMAC** registers is 0 and the device is in that mode, then the module behaves differently depending on the value of the corresponding P_n bit in the **PCEMAC** register. In this case, when the P_n bit is clear the module is not powered and does not receive a clock. If the P_n bit is set, the module is powered but does not receive a clock. The table below details the differences.

Table 5-34. Module Power Control

R _n , S _n or D _n Value in Respective RCGC _x , SCGC _x , or DCGC _x Register	P _n	Description
0	0	Module is not powered and does not receive a clock. In this case, the peripheral's state is not retained. This is the lowest power consumption state of any peripheral since it consumes no dynamic nor leakage current. Hardware should perform a peripheral reset if the active mode changes and the RCGC_x , SCGC_x , or DCGC_x register is a 1 or the P0 bit is changed to a 1. Software must re-initialize the peripheral when re-enabled due to the loss of state.
0	1	Module is powered, but does not receive a clock. In this case, the peripheral is inactive. This is the second-lowest power consumption of any peripheral since it consumes only leakage current.
1	X	Module is powered and receives a clock.

Ethernet MAC Power Control (PCEMAC)

Base 0x400F.E000
Offset 0x99C
Type RW, reset 0x0000.0001

	31	30	29	28	27	26	25	24	23	22	21	20	19	18	17	16	
	reserved																
Type	RO	RO	RO	RO	RO	RO	RO	RO	RO	RO	RO	RO	RO	RO	RO	RO	
Reset	0	0	0	0	0	0	0	0	0	0	0	0	0	0	0	0	
	15	14	13	12	11	10	9	8	7	6	5	4	3	2	1	0	
	reserved															P0	
Type	RO	RO	RO	RO	RO	RO	RO	RO	RO	RO	RO	RO	RO	RO	RO	RO	RW
Reset	0	0	0	0	0	0	0	0	0	0	0	0	0	0	0	0	1

Bit/Field	Name	Type	Reset	Description
31:1	reserved	RO	0	Software should not rely on the value of a reserved bit. To provide compatibility with future products, the value of a reserved bit should be preserved across a read-modify-write operation.

Bit/Field	Name	Type	Reset	Description
0	P0	RW	1	<p>Ethernet MAC Module 0 Power Control</p> <p>The Pn bit encodings are not applicable if the corresponding bit in the RCGCEMAC, SCGCEMAC or DCGCEMAC register is clear.</p> <p>Value Description</p> <p>0 Ethernet MAC Module 0 is not powered and does not receive a clock. In this case, the module's state is not retained. This configuration provides the lowest power consumption state.</p> <p>1 Ethernet MAC module 0 is powered, but does not receive a clock. In this case, the module is inactive.</p>

Register 163: Watchdog Timer Peripheral Ready (PRWD), offset 0xA00

The **PRWD** register indicates whether the watchdog modules are ready to be accessed by software following a change in status of power, Run mode clocking, or reset. A power change is initiated if the corresponding **PCWD** bit is changed from 0 to 1. A Run mode clocking change is initiated if the corresponding **RCGCWD** bit is changed. A reset change is initiated if the corresponding **SRWD** bit is changed from 0 to 1.

The **PRWD** bit is cleared on any of the above events and is not set again until the module is completely powered, enabled, and internally reset.

Watchdog Timer Peripheral Ready (PRWD)

Base 0x400F.E000

Offset 0xA00

Type RO, reset 0x0000.0000

	31	30	29	28	27	26	25	24	23	22	21	20	19	18	17	16	
	reserved																
Type	RO	RO	RO	RO	RO	RO	RO	RO	RO	RO	RO	RO	RO	RO	RO	RO	
Reset	0	0	0	0	0	0	0	0	0	0	0	0	0	0	0	0	
	15	14	13	12	11	10	9	8	7	6	5	4	3	2	1	0	
	reserved															R1	R0
Type	RO	RO	RO	RO	RO	RO	RO	RO	RO	RO	RO	RO	RO	RO	RO	RO	
Reset	0	0	0	0	0	0	0	0	0	0	0	0	0	0	0	0	

Bit/Field	Name	Type	Reset	Description
31:2	reserved	RO	0	Software should not rely on the value of a reserved bit. To provide compatibility with future products, the value of a reserved bit should be preserved across a read-modify-write operation.
1	R1	RO	0	Watchdog Timer 1 Peripheral Ready Value Description 0 Watchdog module 1 is not ready for access. It is unlocked, unpowered, or in the process of completing a reset sequence. 1 Watchdog module 1 is ready for access.
0	R0	RO	0	Watchdog Timer 0 Peripheral Ready Value Description 0 Watchdog module 0 is not ready for access. It is unlocked, unpowered, or in the process of completing a reset sequence. 1 Watchdog module 0 is ready for access.

Register 164: 16/32-Bit General-Purpose Timer Peripheral Ready (PRTIMER), offset 0xA04

The **PRGPT32** register indicates whether the timer modules are ready to be accessed by software following a change in status of power, Run mode clocking, or reset. A power change is initiated if the corresponding **PCGPT32** bit is changed from 0 to 1. A Run mode clocking change is initiated if the corresponding **RCGCGPT32** bit is changed. A reset change is initiated if the corresponding **SRGPT32** bit is changed from 0 to 1.

The **PRGPT32** bit is cleared on any of the above events and is not set again until the module is completely powered, enabled, and internally reset.

16/32-Bit General-Purpose Timer Peripheral Ready (PRTIMER)

Base 0x400F.E000
 Offset 0xA04
 Type RO, reset 0x0000.0000

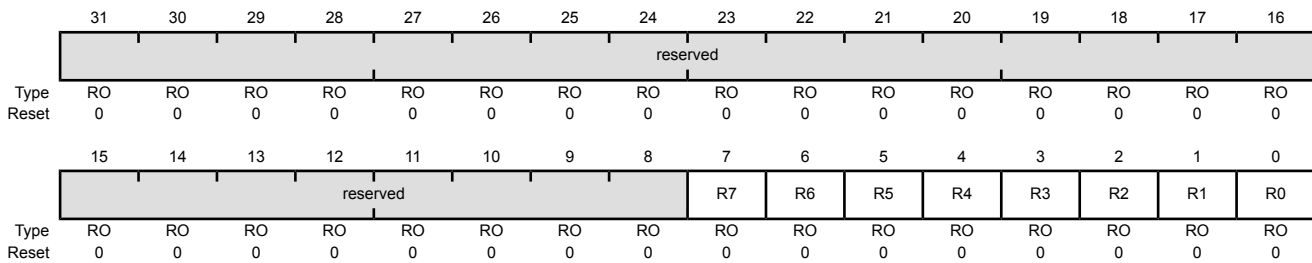

Bit/Field	Name	Type	Reset	Description
31:8	reserved	RO	0	Software should not rely on the value of a reserved bit. To provide compatibility with future products, the value of a reserved bit should be preserved across a read-modify-write operation.
7	R7	RO	0	16/32-Bit General-Purpose Timer 7 Peripheral Ready Value Description 0 16/32-bit timer module 7 is not ready for access. It is unlocked, unpowered, or in the process of completing a reset sequence. 1 16/32-bit timer module 7 is ready for access.
6	R6	RO	0	16/32-Bit General-Purpose Timer 6 Peripheral Ready Value Description 0 16/32-bit timer module 6 is not ready for access. It is unlocked, unpowered, or in the process of completing a reset sequence. 1 16/32-bit timer module 6 is ready for access.
5	R5	RO	0	16/32-Bit General-Purpose Timer 5 Peripheral Ready Value Description 0 16/32-bit timer module 5 is not ready for access. It is unlocked, unpowered, or in the process of completing a reset sequence. 1 16/32-bit timer module 5 is ready for access.

Bit/Field	Name	Type	Reset	Description
4	R4	RO	0	16/32-Bit General-Purpose Timer 4 Peripheral Ready Value Description 0 16/32-bit timer module 4 is not ready for access. It is unlocked, unpowered, or in the process of completing a reset sequence. 1 16/32-bit timer module 4 is ready for access.
3	R3	RO	0	16/32-Bit General-Purpose Timer 3 Peripheral Ready Value Description 0 16/32-bit timer module 3 is not ready for access. It is unlocked, unpowered, or in the process of completing a reset sequence. 1 16/32-bit timer module 3 is ready for access.
2	R2	RO	0	16/32-Bit General-Purpose Timer 2 Peripheral Ready Value Description 0 16/32-bit timer module 2 is not ready for access. It is unlocked, unpowered, or in the process of completing a reset sequence. 1 16/32-bit timer module 2 is ready for access.
1	R1	RO	0	16/32-Bit General-Purpose Timer 1 Peripheral Ready Value Description 0 16/32-bit timer module 1 is not ready for access. It is unlocked, unpowered, or in the process of completing a reset sequence. 1 16/32-bit timer module 1 is ready for access.
0	R0	RO	0	16/32-Bit General-Purpose Timer 0 Peripheral Ready Value Description 0 16/32-bit timer module 0 is not ready for access. It is unlocked, unpowered, or in the process of completing a reset sequence. 1 16/32-bit timer module 0 is ready for access.

Register 165: General-Purpose Input/Output Peripheral Ready (PRGPIO), offset 0xA08

The **PRGPIO** register indicates whether the GPIO modules are ready to be accessed by software following a change in status of power, Run mode clocking, or reset. A power change is initiated if the corresponding **PCGPIO** bit is changed from 0 to 1. A Run mode clocking change is initiated if the corresponding **RCGCGPIO** bit is changed. A reset change is initiated if the corresponding **SRGPIO** bit is changed from 0 to 1.

The **PRGPIO** bit is cleared on any of the above events and is not set again until the module is completely powered, enabled, and internally reset.

General-Purpose Input/Output Peripheral Ready (PRGPIO)

Base 0x400F.E000
 Offset 0xA08
 Type RO, reset 0x0000.0000

	31	30	29	28	27	26	25	24	23	22	21	20	19	18	17	16
	reserved															
Type	RO	RO	RO	RO	RO	RO	RO	RO	RO	RO	RO	RO	RO	RO	RO	RO
Reset	0	0	0	0	0	0	0	0	0	0	0	0	0	0	0	0
	15	14	13	12	11	10	9	8	7	6	5	4	3	2	1	0
	reserved	R14	R13	R12	R11	R10	R9	R8	R7	R6	R5	R4	R3	R2	R1	R0
Type	RO	RO	RO	RO	RO	RO	RO	RO	RO	RO	RO	RO	RO	RO	RO	RO
Reset	0	0	0	0	0	0	0	0	0	0	0	0	0	0	0	0

Bit/Field	Name	Type	Reset	Description
31:15	reserved	RO	0	Software should not rely on the value of a reserved bit. To provide compatibility with future products, the value of a reserved bit should be preserved across a read-modify-write operation.
14	R14	RO	0	GPIO Port Q Peripheral Ready Value Description 0 GPIO Port Q is not ready for access. It is unlocked, unpowered, or in the process of completing a reset sequence. 1 GPIO Port Q is ready for access.
13	R13	RO	0	GPIO Port P Peripheral Ready Value Description 0 GPIO Port P is not ready for access. It is unlocked, unpowered, or in the process of completing a reset sequence. 1 GPIO Port P is ready for access.
12	R12	RO	0	GPIO Port N Peripheral Ready Value Description 0 GPIO Port N is not ready for access. It is unlocked, unpowered, or in the process of completing a reset sequence. 1 GPIO Port N is ready for access.

Bit/Field	Name	Type	Reset	Description
11	R11	RO	0	GPIO Port M Peripheral Ready Value Description 0 GPIO Port M is not ready for access. It is unlocked, unpowered, or in the process of completing a reset sequence. 1 GPIO Port M is ready for access.
10	R10	RO	0	GPIO Port L Peripheral Ready Value Description 0 GPIO Port L is not ready for access. It is unlocked, unpowered, or in the process of completing a reset sequence. 1 GPIO Port L is ready for access.
9	R9	RO	0	GPIO Port K Peripheral Ready Value Description 0 GPIO Port K is not ready for access. It is unlocked, unpowered, or in the process of completing a reset sequence. 1 GPIO Port K is ready for access.
8	R8	RO	0	GPIO Port J Peripheral Ready Value Description 0 GPIO Port J is not ready for access. It is unlocked, unpowered, or in the process of completing a reset sequence. 1 GPIO Port J is ready for access.
7	R7	RO	0	GPIO Port H Peripheral Ready Value Description 0 GPIO Port H is not ready for access. It is unlocked, unpowered, or in the process of completing a reset sequence. 1 GPIO Port H is ready for access.
6	R6	RO	0	GPIO Port G Peripheral Ready Value Description 0 GPIO Port G is not ready for access. It is unlocked, unpowered, or in the process of completing a reset sequence. 1 GPIO Port G is ready for access.
5	R5	RO	0	GPIO Port F Peripheral Ready Value Description 0 GPIO Port F is not ready for access. It is unlocked, unpowered, or in the process of completing a reset sequence. 1 GPIO Port F is ready for access.

Bit/Field	Name	Type	Reset	Description
4	R4	RO	0	GPIO Port E Peripheral Ready Value Description 0 GPIO Port E is not ready for access. It is unlocked, unpowered, or in the process of completing a reset sequence. 1 GPIO Port E is ready for access.
3	R3	RO	0	GPIO Port D Peripheral Ready Value Description 0 GPIO Port D is not ready for access. It is unlocked, unpowered, or in the process of completing a reset sequence. 1 GPIO Port D is ready for access.
2	R2	RO	0	GPIO Port C Peripheral Ready Value Description 0 GPIO Port C is not ready for access. It is unlocked, unpowered, or in the process of completing a reset sequence. 1 GPIO Port C is ready for access.
1	R1	RO	0	GPIO Port B Peripheral Ready Value Description 0 GPIO Port B is not ready for access. It is unlocked, unpowered, or in the process of completing a reset sequence. 1 GPIO Port B is ready for access.
0	R0	RO	0	GPIO Port A Peripheral Ready Value Description 0 GPIO Port A is not ready for access. It is unlocked, unpowered, or in the process of completing a reset sequence. 1 GPIO Port A is ready for access.

Register 166: Micro Direct Memory Access Peripheral Ready (PRDMA), offset 0xA0C

The **PRDMA** register indicates whether the μ DMA module is ready to be accessed by software following a change in status of power, Run mode clocking, or reset. A power change is initiated if the corresponding **PCDMA** bit is changed from 0 to 1. A Run mode clocking change is initiated if the corresponding **RCGCDMA** bit is changed. A reset change is initiated if the corresponding **SRDMA** bit is changed from 0 to 1.

The **PRDMA** bit is cleared on any of the above events and is not set again until the module is completely powered, enabled, and internally reset.

Micro Direct Memory Access Peripheral Ready (PRDMA)

Base 0x400F.E000

Offset 0xA0C

Type RO, reset 0x0000.0000

	31	30	29	28	27	26	25	24	23	22	21	20	19	18	17	16
	reserved															
Type	RO	RO	RO	RO	RO	RO	RO	RO	RO	RO	RO	RO	RO	RO	RO	RO
Reset	0	0	0	0	0	0	0	0	0	0	0	0	0	0	0	0
	15	14	13	12	11	10	9	8	7	6	5	4	3	2	1	0
	reserved															RO
Type	RO	RO	RO	RO	RO	RO	RO	RO	RO	RO	RO	RO	RO	RO	RO	RO
Reset	0	0	0	0	0	0	0	0	0	0	0	0	0	0	0	0

Bit/Field	Name	Type	Reset	Description
31:1	reserved	RO	0	Software should not rely on the value of a reserved bit. To provide compatibility with future products, the value of a reserved bit should be preserved across a read-modify-write operation.
0	R0	RO	0	μ DMA Module Peripheral Ready
				Value Description
			0	The μ DMA module is not ready for access. It is unclocked, unpowered, or in the process of completing a reset sequence.
			1	The μ DMA module is ready for access.

Register 167: EPI Peripheral Ready (PREPI), offset 0xA10

The **PREPI** register indicates whether the EPI module is ready to be accessed by software following a change in status of power, Run mode clocking, or reset. A power change is initiated if the corresponding **PCEPI** bit is changed from 0 to 1. A Run mode clocking change is initiated if the corresponding **RCGCEPI** bit is changed. A reset change is initiated if the corresponding **SREPI** bit is changed from 0 to 1.

The **PREPI** bit is cleared on any of the above events and is not set again until the module is completely powered, enabled, and internally reset.

EPI Peripheral Ready (PREPI)

Base 0x400F.E000
 Offset 0xA10
 Type RO, reset 0x0000.0000

	31	30	29	28	27	26	25	24	23	22	21	20	19	18	17	16
	reserved															
Type	RO	RO	RO	RO	RO	RO	RO	RO	RO	RO	RO	RO	RO	RO	RO	RO
Reset	0	0	0	0	0	0	0	0	0	0	0	0	0	0	0	0
	15	14	13	12	11	10	9	8	7	6	5	4	3	2	1	0
	reserved															RO
Type	RO	RO	RO	RO	RO	RO	RO	RO	RO	RO	RO	RO	RO	RO	RO	RO
Reset	0	0	0	0	0	0	0	0	0	0	0	0	0	0	0	0

Bit/Field	Name	Type	Reset	Description
31:1	reserved	RO	0	Software should not rely on the value of a reserved bit. To provide compatibility with future products, the value of a reserved bit should be preserved across a read-modify-write operation.
0	R0	RO	0	EPI Module Peripheral Ready
Value Description				
	0	The EPI module is not ready for access. It is unclocked, unpowered, or in the process of completing a reset sequence.		
	1	The EPI module is ready for access.		

Register 168: Hibernation Peripheral Ready (PRHIB), offset 0xA14

The **PRHIB** register indicates whether the Hibernation module is ready to be accessed by software following a change in status of power, Run mode clocking, or reset. A power change is initiated if the corresponding **PCHIB** bit is changed from 0 to 1. A Run mode clocking change is initiated if the corresponding **RCGCHIB** bit is changed. A reset change is initiated if the corresponding **SRHIB** bit is changed from 0 to 1.

The **PRHIB** bit is cleared on any of the above events and is not set again until the module is completely powered, enabled, and internally reset.

Hibernation Peripheral Ready (PRHIB)

Base 0x400F.E000

Offset 0xA14

Type RO, reset 0x0000.0001

	31	30	29	28	27	26	25	24	23	22	21	20	19	18	17	16
	reserved															
Type	RO	RO	RO	RO	RO	RO	RO	RO	RO	RO	RO	RO	RO	RO	RO	RO
Reset	0	0	0	0	0	0	0	0	0	0	0	0	0	0	0	0
	15	14	13	12	11	10	9	8	7	6	5	4	3	2	1	0
	reserved															RO
Type	RO	RO	RO	RO	RO	RO	RO	RO	RO	RO	RO	RO	RO	RO	RO	RO
Reset	0	0	0	0	0	0	0	0	0	0	0	0	0	0	0	1

Bit/Field	Name	Type	Reset	Description
31:1	reserved	RO	0	Software should not rely on the value of a reserved bit. To provide compatibility with future products, the value of a reserved bit should be preserved across a read-modify-write operation.
0	R0	RO	1	Hibernation Module Peripheral Ready
				Value Description
			0	The Hibernation module is not ready for access. It is unlocked, unpowered, or in the process of completing a reset sequence.
			1	The Hibernation module is ready for access.

Register 169: Universal Asynchronous Receiver/Transmitter Peripheral Ready (PRUART), offset 0xA18

The **PRUART** register indicates whether the UART modules are ready to be accessed by software following a change in status of power, Run mode clocking, or reset. A power change is initiated if the corresponding **PCUART** bit is changed from 0 to 1. A Run mode clocking change is initiated if the corresponding **RCGCUART** bit is changed. A reset change is initiated if the corresponding **SRUART** bit is changed from 0 to 1.

The **PRUART** bit is cleared on any of the above events and is not set again until the module is completely powered, enabled, and internally reset.

Universal Asynchronous Receiver/Transmitter Peripheral Ready (PRUART)

Base 0x400F.E000
 Offset 0xA18
 Type RO, reset 0x0000.0000

	31	30	29	28	27	26	25	24	23	22	21	20	19	18	17	16
	reserved															
Type	RO	RO	RO	RO	RO	RO	RO	RO	RO	RO	RO	RO	RO	RO	RO	RO
Reset	0	0	0	0	0	0	0	0	0	0	0	0	0	0	0	0
	15	14	13	12	11	10	9	8	7	6	5	4	3	2	1	0
	reserved								R7	R6	R5	R4	R3	R2	R1	R0
Type	RO	RO	RO	RO	RO	RO	RO	RO	RO	RO	RO	RO	RO	RO	RO	RO
Reset	0	0	0	0	0	0	0	0	0	0	0	0	0	0	0	0

Bit/Field	Name	Type	Reset	Description
31:8	reserved	RO	0	Software should not rely on the value of a reserved bit. To provide compatibility with future products, the value of a reserved bit should be preserved across a read-modify-write operation.
7	R7	RO	0	UART Module 7 Peripheral Ready Value Description 0 UART module 7 is not ready for access. It is unlocked, unpowered, or in the process of completing a reset sequence. 1 UART module 7 is ready for access.
6	R6	RO	0	UART Module 6 Peripheral Ready Value Description 0 UART module 6 is not ready for access. It is unlocked, unpowered, or in the process of completing a reset sequence. 1 UART module 6 is ready for access.
5	R5	RO	0	UART Module 5 Peripheral Ready Value Description 0 UART module 5 is not ready for access. It is unlocked, unpowered, or in the process of completing a reset sequence. 1 UART module 5 is ready for access.

Bit/Field	Name	Type	Reset	Description
4	R4	RO	0	UART Module 4 Peripheral Ready Value Description 0 UART module 4 is not ready for access. It is unlocked, unpowered, or in the process of completing a reset sequence. 1 UART module 4 is ready for access.
3	R3	RO	0	UART Module 3 Peripheral Ready Value Description 0 UART module 3 is not ready for access. It is unlocked, unpowered, or in the process of completing a reset sequence. 1 UART module 3 is ready for access.
2	R2	RO	0	UART Module 2 Peripheral Ready Value Description 0 UART module 2 is not ready for access. It is unlocked, unpowered, or in the process of completing a reset sequence. 1 UART module 2 is ready for access.
1	R1	RO	0	UART Module 1 Peripheral Ready Value Description 0 UART module 1 is not ready for access. It is unlocked, unpowered, or in the process of completing a reset sequence. 1 UART module 1 is ready for access.
0	R0	RO	0	UART Module 0 Peripheral Ready Value Description 0 UART module 0 is not ready for access. It is unlocked, unpowered, or in the process of completing a reset sequence. 1 UART module 0 is ready for access.

Register 170: Synchronous Serial Interface Peripheral Ready (PRSSI), offset 0xA1C

The **PRSSI** register indicates whether the SSI modules are ready to be accessed by software following a change in status of power, Run mode clocking, or reset. A power change is initiated if the corresponding **PCSSI** bit is changed from 0 to 1. A Run mode clocking change is initiated if the corresponding **RCGCSI** bit is changed. A reset change is initiated if the corresponding **SRSSI** bit is changed from 0 to 1.

The **PRSSI** bit is cleared on any of the above events and is not set again until the module is completely powered, enabled, and internally reset.

Synchronous Serial Interface Peripheral Ready (PRSSI)

Base 0x400F.E000
 Offset 0xA1C
 Type RO, reset 0x0000.0000

	31	30	29	28	27	26	25	24	23	22	21	20	19	18	17	16	
	reserved																
Type	RO	RO	RO	RO	RO	RO	RO	RO	RO	RO	RO	RO	RO	RO	RO	RO	
Reset	0	0	0	0	0	0	0	0	0	0	0	0	0	0	0	0	
	15	14	13	12	11	10	9	8	7	6	5	4	3	2	1	0	
	reserved													R3	R2	R1	R0
Type	RO	RO	RO	RO	RO	RO	RO	RO	RO	RO	RO	RO	RO	RO	RO	RO	
Reset	0	0	0	0	0	0	0	0	0	0	0	0	0	0	0	0	

Bit/Field	Name	Type	Reset	Description
31:4	reserved	RO	0	Software should not rely on the value of a reserved bit. To provide compatibility with future products, the value of a reserved bit should be preserved across a read-modify-write operation.
3	R3	RO	0	SSI Module 3 Peripheral Ready Value Description 0 SSI module 3 is not ready for access. It is unlocked, unpowered, or in the process of completing a reset sequence. 1 SSI module 3 is ready for access.
2	R2	RO	0	SSI Module 2 Peripheral Ready Value Description 0 SSI module 2 is not ready for access. It is unlocked, unpowered, or in the process of completing a reset sequence. 1 SSI module 2 is ready for access.
1	R1	RO	0	SSI Module 1 Peripheral Ready Value Description 0 SSI module 1 is not ready for access. It is unlocked, unpowered, or in the process of completing a reset sequence. 1 SSI module 1 is ready for access.

Bit/Field	Name	Type	Reset	Description
0	R0	RO	0	SSI Module 0 Peripheral Ready
				Value Description
				0 SSI module 0 is not ready for access. It is unlocked, unpowered, or in the process of completing a reset sequence.
				1 SSI module 0 is ready for access.

Register 171: Inter-Integrated Circuit Peripheral Ready (PRI2C), offset 0xA20

The **PRI2C** register indicates whether the I²C modules are ready to be accessed by software following a change in status of power, Run mode clocking, or reset. A power change is initiated if the corresponding **PCI2C** bit is changed from 0 to 1. A Run mode clocking change is initiated if the corresponding **RCGCI2C** bit is changed. A reset change is initiated if the corresponding **SRI2C** bit is changed from 0 to 1.

The **PRI2C** bit is cleared on any of the above events and is not set again until the module is completely powered, enabled, and internally reset.

Inter-Integrated Circuit Peripheral Ready (PRI2C)

Base 0x400F.E000
 Offset 0xA20
 Type RO, reset 0x0000.0000

	31	30	29	28	27	26	25	24	23	22	21	20	19	18	17	16	
	reserved																
Type	RO	RO	RO	RO	RO	RO	RO	RO	RO	RO	RO	RO	RO	RO	RO	RO	
Reset	0	0	0	0	0	0	0	0	0	0	0	0	0	0	0	0	
	15	14	13	12	11	10	9	8	7	6	5	4	3	2	1	0	
	reserved							R9	R8	R7	R6	R5	R4	R3	R2	R1	R0
Type	RO	RO	RO	RO	RO	RO	RO	RO	RO	RO	RO	RO	RO	RO	RO	RO	
Reset	0	0	0	0	0	0	0	0	0	0	0	0	0	0	0	0	

Bit/Field	Name	Type	Reset	Description
31:10	reserved	RO	0	Software should not rely on the value of a reserved bit. To provide compatibility with future products, the value of a reserved bit should be preserved across a read-modify-write operation.
9	R9	RO	0	I ² C Module 9 Peripheral Ready Value Description 0 I ² C module 9 is not ready for access. It is unlocked, unpowered, or in the process of completing a reset sequence. 1 I ² C module 9 is ready for access.
8	R8	RO	0	I ² C Module 8 Peripheral Ready Value Description 0 I ² C module 8 is not ready for access. It is unlocked, unpowered, or in the process of completing a reset sequence. 1 I ² C module 8 is ready for access.
7	R7	RO	0	I ² C Module 7 Peripheral Ready Value Description 0 I ² C module 7 is not ready for access. It is unlocked, unpowered, or in the process of completing a reset sequence. 1 I ² C module 7 is ready for access.

Bit/Field	Name	Type	Reset	Description
6	R6	RO	0	I ² C Module 6 Peripheral Ready Value Description 0 I ² C module 6 is not ready for access. It is unlocked, unpowered, or in the process of completing a reset sequence. 1 I ² C module 6 is ready for access.
5	R5	RO	0	I ² C Module 5 Peripheral Ready Value Description 0 I ² C module 5 is not ready for access. It is unlocked, unpowered, or in the process of completing a reset sequence. 1 I ² C module 5 is ready for access.
4	R4	RO	0	I ² C Module 4 Peripheral Ready Value Description 0 I ² C module 4 is not ready for access. It is unlocked, unpowered, or in the process of completing a reset sequence. 1 I ² C module 4 is ready for access.
3	R3	RO	0	I ² C Module 3 Peripheral Ready Value Description 0 I ² C module 3 is not ready for access. It is unlocked, unpowered, or in the process of completing a reset sequence. 1 I ² C module 3 is ready for access.
2	R2	RO	0	I ² C Module 2 Peripheral Ready Value Description 0 I ² C module 2 is not ready for access. It is unlocked, unpowered, or in the process of completing a reset sequence. 1 I ² C module 2 is ready for access.
1	R1	RO	0	I ² C Module 1 Peripheral Ready Value Description 0 I ² C module 1 is not ready for access. It is unlocked, unpowered, or in the process of completing a reset sequence. 1 I ² C module 1 is ready for access.

Bit/Field	Name	Type	Reset	Description
0	R0	RO	0	I ² C Module 0 Peripheral Ready
				Value Description
				0 I ² C module 0 is not ready for access. It is unlocked, unpowered, or in the process of completing a reset sequence.
				1 I ² C module 0 is ready for access.

Register 172: Universal Serial Bus Peripheral Ready (PRUSB), offset 0xA28

The **PRUSB** register indicates whether the USB module is ready to be accessed by software following a change in status of power, Run mode clocking, or reset. A power change is initiated if the corresponding **PCUSB** bit is changed from 0 to 1. A Run mode clocking change is initiated if the corresponding **RCGCUSB** bit is changed. A reset change is initiated if the corresponding **SRUSB** bit is changed from 0 to 1.

The **PRUSB** bit is cleared on any of the above events and is not set again until the module is completely powered, enabled, and internally reset.

Universal Serial Bus Peripheral Ready (PRUSB)

Base 0x400F.E000

Offset 0xA28

Type RO, reset 0x0000.0000

	31	30	29	28	27	26	25	24	23	22	21	20	19	18	17	16
	reserved															
Type	RO	RO	RO	RO	RO	RO	RO	RO	RO	RO	RO	RO	RO	RO	RO	RO
Reset	0	0	0	0	0	0	0	0	0	0	0	0	0	0	0	0
	15	14	13	12	11	10	9	8	7	6	5	4	3	2	1	0
	reserved															RO
Type	RO	RO	RO	RO	RO	RO	RO	RO	RO	RO	RO	RO	RO	RO	RO	RO
Reset	0	0	0	0	0	0	0	0	0	0	0	0	0	0	0	0

Bit/Field	Name	Type	Reset	Description
31:1	reserved	RO	0	Software should not rely on the value of a reserved bit. To provide compatibility with future products, the value of a reserved bit should be preserved across a read-modify-write operation.
0	R0	RO	0	USB Module Peripheral Ready

Value Description

0	The USB module is not ready for access. It is unlocked, unpowered, or in the process of completing a reset sequence.
1	The USB module is ready for access.

Register 173: Ethernet PHY Peripheral Ready (PREPHY), offset 0xA30

The **PREPHY** register indicates whether the Ethernet PHY module is ready to be accessed by software following a change in status of power, Run mode clocking, or reset. A power change is initiated if the corresponding **PCEPHY** bit is changed from 0 to 1. A Run mode clocking change is initiated if the corresponding **RCGCEPHY** bit is changed. A reset change is initiated if the corresponding **SREPHY** bit is changed from 0 to 1.

The **PREPHY** bit is cleared on any of the above events and is not set again until the module is completely powered, enabled, and internally reset.

Ethernet PHY Peripheral Ready (PREPHY)

Base 0x400F.E000
 Offset 0xA30
 Type RO, reset 0x0000.0000

	31	30	29	28	27	26	25	24	23	22	21	20	19	18	17	16
	reserved															
Type	RO	RO	RO	RO	RO	RO	RO	RO	RO	RO	RO	RO	RO	RO	RO	RO
Reset	0	0	0	0	0	0	0	0	0	0	0	0	0	0	0	0
	15	14	13	12	11	10	9	8	7	6	5	4	3	2	1	0
	reserved															
Type	RO	RO	RO	RO	RO	RO	RO	RO	RO	RO	RO	RO	RO	RO	RO	RO
Reset	0	0	0	0	0	0	0	0	0	0	0	0	0	0	0	0

Bit/Field	Name	Type	Reset	Description
31:1	reserved	RO	0	Software should not rely on the value of a reserved bit. To provide compatibility with future products, the value of a reserved bit should be preserved across a read-modify-write operation.
0	R0	RO	0	Ethernet PHY Module Peripheral Ready

Value	Description
0	The Ethernet PHY module is not ready for access. It is unclocked, unpowered, or in the process of completing a reset sequence.
1	The Ethernet PHY module is ready for access.

Register 174: Controller Area Network Peripheral Ready (PRCAN), offset 0xA34

The **PRCAN** register indicates whether the CAN modules are ready to be accessed by software following a change in status of power, Run mode clocking, or reset. A power change is initiated if the corresponding **PCCAN** bit is changed from 0 to 1. A Run mode clocking change is initiated if the corresponding **RCGCCAN** bit is changed. A reset change is initiated if the corresponding **SRCAN** bit is changed from 0 to 1.

The **PRCAN** bit is cleared on any of the above events and is not set again until the module is completely powered, enabled, and internally reset.

Controller Area Network Peripheral Ready (PRCAN)

Base 0x400F.E000

Offset 0xA34

Type RO, reset 0x0000.0000

	31	30	29	28	27	26	25	24	23	22	21	20	19	18	17	16	
	reserved																
Type	RO	RO	RO	RO	RO	RO	RO	RO	RO	RO	RO	RO	RO	RO	RO	RO	
Reset	0	0	0	0	0	0	0	0	0	0	0	0	0	0	0	0	
	15	14	13	12	11	10	9	8	7	6	5	4	3	2	1	0	
	reserved															R1	R0
Type	RO	RO	RO	RO	RO	RO	RO	RO	RO	RO	RO	RO	RO	RO	RO	RO	RO
Reset	0	0	0	0	0	0	0	0	0	0	0	0	0	0	0	0	0

Bit/Field	Name	Type	Reset	Description
31:2	reserved	RO	0	Software should not rely on the value of a reserved bit. To provide compatibility with future products, the value of a reserved bit should be preserved across a read-modify-write operation.
1	R1	RO	0	CAN Module 1 Peripheral Ready Value Description 0 CAN module 1 is not ready for access. It is unlocked, unpowered, or in the process of completing a reset sequence. 1 CAN module 1 is ready for access.
0	R0	RO	0	CAN Module 0 Peripheral Ready Value Description 0 CAN module 0 is not ready for access. It is unlocked, unpowered, or in the process of completing a reset sequence. 1 CAN module 0 is ready for access.

Register 175: Analog-to-Digital Converter Peripheral Ready (PRADC), offset 0xA38

The **PRADC** register indicates whether the ADC modules are ready to be accessed by software following a change in status of power, Run mode clocking, or reset. A power change is initiated if the corresponding **PCADC** bit is changed from 0 to 1. A Run mode clocking change is initiated if the corresponding **RCGCADC** bit is changed. A reset change is initiated if the corresponding **SRADC** bit is changed from 0 to 1.

The **PRADC** bit is cleared on any of the above events and is not set again until the module is completely powered, enabled, and internally reset.

Analog-to-Digital Converter Peripheral Ready (PRADC)

Base 0x400F.E000
 Offset 0xA38
 Type RO, reset 0x0000.0000

	31	30	29	28	27	26	25	24	23	22	21	20	19	18	17	16	
	reserved																
Type	RO	RO	RO	RO	RO	RO	RO	RO	RO	RO	RO	RO	RO	RO	RO	RO	
Reset	0	0	0	0	0	0	0	0	0	0	0	0	0	0	0	0	
	15	14	13	12	11	10	9	8	7	6	5	4	3	2	1	0	
	reserved															R1	R0
Type	RO	RO	RO	RO	RO	RO	RO	RO	RO	RO	RO	RO	RO	RO	RO	RO	RO
Reset	0	0	0	0	0	0	0	0	0	0	0	0	0	0	0	0	0

Bit/Field	Name	Type	Reset	Description
31:2	reserved	RO	0	Software should not rely on the value of a reserved bit. To provide compatibility with future products, the value of a reserved bit should be preserved across a read-modify-write operation.
1	R1	RO	0	ADC Module 1 Peripheral Ready Value Description 0 ADC module 1 is not ready for access. It is unlocked, unpowered, or in the process of completing a reset sequence. 1 ADC module 1 is ready for access.
0	R0	RO	0	ADC Module 0 Peripheral Ready Value Description 0 ADC module 0 is not ready for access. It is unlocked, unpowered, or in the process of completing a reset sequence. 1 ADC module 0 is ready for access.

Register 176: Analog Comparator Peripheral Ready (PRACMP), offset 0xA3C

The **PRACMP** register indicates whether the analog comparator module is ready to be accessed by software following a change in status of power, Run mode clocking, or reset. A power change is initiated if the corresponding **PCACMP** bit is changed from 0 to 1. A Run mode clocking change is initiated if the corresponding **RCGCACMP** bit is changed. A reset change is initiated if the corresponding **SRACMP** bit is changed from 0 to 1.

The **PRACMP** bit is cleared on any of the above events and is not set again until the module is completely powered, enabled, and internally reset.

Analog Comparator Peripheral Ready (PRACMP)

Base 0x400F.E000

Offset 0xA3C

Type RO, reset 0x0000.0000

	31	30	29	28	27	26	25	24	23	22	21	20	19	18	17	16
	reserved															
Type	RO	RO	RO	RO	RO	RO	RO	RO	RO	RO	RO	RO	RO	RO	RO	RO
Reset	0	0	0	0	0	0	0	0	0	0	0	0	0	0	0	0
	15	14	13	12	11	10	9	8	7	6	5	4	3	2	1	0
	reserved															RO
Type	RO	RO	RO	RO	RO	RO	RO	RO	RO	RO	RO	RO	RO	RO	RO	RO
Reset	0	0	0	0	0	0	0	0	0	0	0	0	0	0	0	0

Bit/Field	Name	Type	Reset	Description
31:1	reserved	RO	0	Software should not rely on the value of a reserved bit. To provide compatibility with future products, the value of a reserved bit should be preserved across a read-modify-write operation.
0	R0	RO	0	Analog Comparator Module 0 Peripheral Ready
				Value Description
			0	The analog comparator module is not ready for access. It is unlocked, unpowered, or in the process of completing a reset sequence.
			1	The analog comparator module is ready for access.

Register 177: Pulse Width Modulator Peripheral Ready (PRPWM), offset 0xA40

The **PRPWM** register indicates whether the PWM modules are ready to be accessed by software following a change in status of power, Run mode clocking, or reset. A power change is initiated if the corresponding **PCPWM** bit is changed from 0 to 1. A Run mode clocking change is initiated if the corresponding **RCGCPWM** bit is changed. A reset change is initiated if the corresponding **SRPWM** bit is changed from 0 to 1.

The **PRPWM** bit is cleared on any of the above events and is not set again until the module is completely powered, enabled, and internally reset.

Pulse Width Modulator Peripheral Ready (PRPWM)

Base 0x400F.E000
 Offset 0xA40
 Type RO, reset 0x0000.0000

	31	30	29	28	27	26	25	24	23	22	21	20	19	18	17	16
	reserved															
Type	RO	RO	RO	RO	RO	RO	RO	RO	RO	RO	RO	RO	RO	RO	RO	RO
Reset	0	0	0	0	0	0	0	0	0	0	0	0	0	0	0	0
	15	14	13	12	11	10	9	8	7	6	5	4	3	2	1	0
	reserved															RO
Type	RO	RO	RO	RO	RO	RO	RO	RO	RO	RO	RO	RO	RO	RO	RO	RO
Reset	0	0	0	0	0	0	0	0	0	0	0	0	0	0	0	0

Bit/Field	Name	Type	Reset	Description	
31:1	reserved	RO	0	Software should not rely on the value of a reserved bit. To provide compatibility with future products, the value of a reserved bit should be preserved across a read-modify-write operation.	
0	R0	RO	0	PWM Module 0 Peripheral Ready	
Value Description					
	0	PWM module 0 is not ready for access. It is unlocked, unpowered, or in the process of completing a reset sequence.			
	1	PWM module 0 is ready for access.			

Register 178: Quadrature Encoder Interface Peripheral Ready (PRQEI), offset 0xA44

The **PRQEI** register indicates whether the QEI modules are ready to be accessed by software following a change in status of power, Run mode clocking, or reset. A power change is initiated if the corresponding **PCQEI** bit is changed from 0 to 1. A Run mode clocking change is initiated if the corresponding **RCGCQEI** bit is changed. A reset change is initiated if the corresponding **SRQEI** bit is changed from 0 to 1.

The **PRQEI** bit is cleared on any of the above events and is not set again until the module is completely powered, enabled, and internally reset.

Quadrature Encoder Interface Peripheral Ready (PRQEI)

Base 0x400F.E000

Offset 0xA44

Type RO, reset 0x0000.0000

	31	30	29	28	27	26	25	24	23	22	21	20	19	18	17	16
	reserved															
Type	RO	RO	RO	RO	RO	RO	RO	RO	RO	RO	RO	RO	RO	RO	RO	RO
Reset	0	0	0	0	0	0	0	0	0	0	0	0	0	0	0	0
	15	14	13	12	11	10	9	8	7	6	5	4	3	2	1	0
	reserved															RO
Type	RO	RO	RO	RO	RO	RO	RO	RO	RO	RO	RO	RO	RO	RO	RO	RO
Reset	0	0	0	0	0	0	0	0	0	0	0	0	0	0	0	0

Bit/Field	Name	Type	Reset	Description
31:1	reserved	RO	0	Software should not rely on the value of a reserved bit. To provide compatibility with future products, the value of a reserved bit should be preserved across a read-modify-write operation.
0	R0	RO	0	QEI Module 0 Peripheral Ready
				Value Description
			0	QEI module 0 is not ready for access. It is unclocked, unpowered, or in the process of completing a reset sequence.
			1	QEI module 0 is ready for access.

Register 179: EEPROM Peripheral Ready (PREEPROM), offset 0xA58

The **PREEPROM** register indicates whether the EEPROM module is ready to be accessed by software following a change in status of power, Run mode clocking, or reset. A power change is initiated if the corresponding **PCEEPROM** bit is changed from 0 to 1. A Run mode clocking change is initiated if the corresponding **RCGCEEPROM** bit is changed. A reset change is initiated if the corresponding **SREEPROM** bit is changed from 0 to 1.

The **PREEPROM** bit is cleared on any of the above events and is not set again until the module is completely powered, enabled, and internally reset.

EEPROM Peripheral Ready (PREEPROM)

Base 0x400F.E000
 Offset 0xA58
 Type RO, reset 0x0000.0000

	31	30	29	28	27	26	25	24	23	22	21	20	19	18	17	16
	reserved															
Type	RO	RO	RO	RO	RO	RO	RO	RO	RO	RO	RO	RO	RO	RO	RO	RO
Reset	0	0	0	0	0	0	0	0	0	0	0	0	0	0	0	0
	15	14	13	12	11	10	9	8	7	6	5	4	3	2	1	0
	reserved															RO
Type	RO	RO	RO	RO	RO	RO	RO	RO	RO	RO	RO	RO	RO	RO	RO	RO
Reset	0	0	0	0	0	0	0	0	0	0	0	0	0	0	0	0

Bit/Field	Name	Type	Reset	Description
31:1	reserved	RO	0	Software should not rely on the value of a reserved bit. To provide compatibility with future products, the value of a reserved bit should be preserved across a read-modify-write operation.
0	R0	RO	0	EEPROM Module 0 Peripheral Ready
				Value Description
				0 The EEPROM module is not ready for access. It is unlocked, unpowered, or in the process of completing a reset sequence.
				1 The EEPROM module is ready for access.

Register 180: CRC and Cryptographic Modules Peripheral Ready (PRCCM), offset 0xA74

The **PRCCM** register indicates whether the CRC and Cryptographic Modules(AES, DES, and SHA/MD5) are ready to be accessed by software following a change in status of power, Run mode clocking, or reset. A power change is initiated if the corresponding **PCCCM** bit is changed from 0 to 1. A Run mode clocking change is initiated if the corresponding **RCGCCM** bit is changed. A reset change is initiated if the corresponding **SRCCM** bit is changed from 0 to 1.

The **PRCCM** bit is cleared on any of the above events and is not set again until the modules are completely powered, enabled, and internally reset.

CRC and Cryptographic Modules Peripheral Ready (PRCCM)

Base 0x400F.E000

Offset 0xA74

Type RO, reset 0x0000.0000

	31	30	29	28	27	26	25	24	23	22	21	20	19	18	17	16
	reserved															
Type	RO	RO	RO	RO	RO	RO	RO	RO	RO	RO	RO	RO	RO	RO	RO	RO
Reset	0	0	0	0	0	0	0	0	0	0	0	0	0	0	0	0
	15	14	13	12	11	10	9	8	7	6	5	4	3	2	1	0
	reserved															RO
Type	RO	RO	RO	RO	RO	RO	RO	RO	RO	RO	RO	RO	RO	RO	RO	RO
Reset	0	0	0	0	0	0	0	0	0	0	0	0	0	0	0	0

Bit/Field	Name	Type	Reset	Description
31:1	reserved	RO	0	Software should not rely on the value of a reserved bit. To provide compatibility with future products, the value of a reserved bit should be preserved across a read-modify-write operation.
0	R0	RO	0	CRC and Cryptographic Modules Peripheral Ready
				Value Description
				0 The CRC, AES, DES, and SHA/MD modules are not ready for access. They are unlocked, unpowered, or in the process of completing a reset sequence.
				1 The CRC, AES, DES, and SHA/MD modules are ready for access.

Register 181: Ethernet MAC Peripheral Ready (PREMAC), offset 0xA9C

The **PREMAC** register indicates whether the Ethernet module is ready to be accessed by software following a change in status of power, Run mode clocking, or reset. A power change is initiated if the corresponding **PCEMAC** bit is changed from 0 to 1. A Run mode clocking change is initiated if the corresponding **RCGCEMAC** bit is changed. A reset change is initiated if the corresponding **SREMAC** bit is changed from 0 to 1.

The **PREMAC** bit is cleared on any of the above events and is not set again until the module is completely powered, enabled, and internally reset.

Ethernet MAC Peripheral Ready (PREMAC)

Base 0x400F.E000
 Offset 0xA9C
 Type RO, reset 0x0000.0000

	31	30	29	28	27	26	25	24	23	22	21	20	19	18	17	16
	reserved															
Type	RO	RO	RO	RO	RO	RO	RO	RO	RO	RO	RO	RO	RO	RO	RO	RO
Reset	0	0	0	0	0	0	0	0	0	0	0	0	0	0	0	0
	15	14	13	12	11	10	9	8	7	6	5	4	3	2	1	0
	reserved															RO
Type	RO	RO	RO	RO	RO	RO	RO	RO	RO	RO	RO	RO	RO	RO	RO	RO
Reset	0	0	0	0	0	0	0	0	0	0	0	0	0	0	0	0

Bit/Field	Name	Type	Reset	Description
31:1	reserved	RO	0	Software should not rely on the value of a reserved bit. To provide compatibility with future products, the value of a reserved bit should be preserved across a read-modify-write operation.
0	R0	RO	0	Ethernet MAC Module 0 Peripheral Ready
				Value Description
				0 Ethernet MAC module 0 is not ready for access. It is unclocked, unpowered, or in the process of completing a reset sequence.
				1 Ethernet MAC module 0 is ready for access.

Register 182: Unique ID 0 (UNIQUEID0), offset 0xF20

Register 183: Unique ID 1 (UNIQUEID1), offset 0xF24

Register 184: Unique ID 2 (UNIQUEID2), offset 0xF28

Register 185: Unique ID 3 (UNIQUEID3), offset 0xF2C

These registers contain a unique 128-bit identifier that cannot be modified by the user. This value is unique to each individual die but is not a random value. This unique device identifier can be used to initiate secure boot processes or as a serial number for USB or other end applications.

Unique ID n (UNIQUEIDn)

Base 0x400F.E000

Offset 0xF20

Type RO, reset -

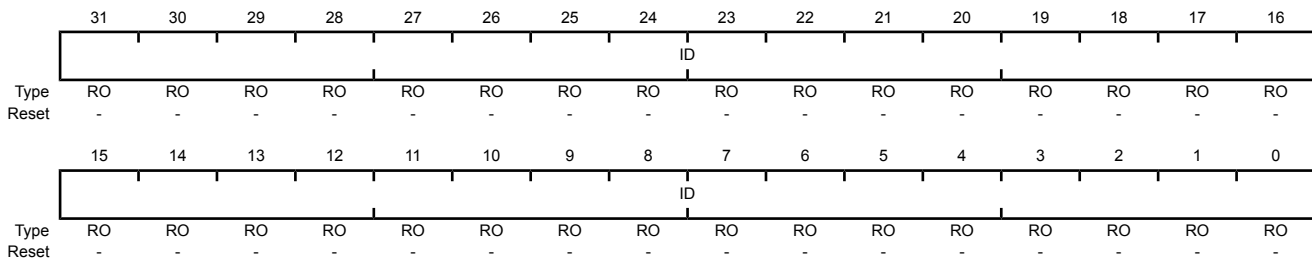

Bit/Field	Name	Type	Reset	Description
31:0	ID	RO	-	Unique ID The result of registers 0-3 concatenated defines the unique 128-bit device identifier.

5.6 Cryptographic System Control Register Description (CCM Offset)

This section lists and describes the system control registers for the CRC and Cryptographic (AES, DES, SHA) Modules. Registers in this section are relative to the CCM base address of 0x4403.0000.

Register 186: Cryptographic Modules Clock Gating Request (CCMCGREQ), offset 0x204

The **Cryptographic Modules Clock Gating Request (CCMCGREQ)** register is written to enable or disable clock gating in the AES, DES, and SHA/MD5 Module.

Cryptographic Modules Clock Gating Request (CCMCGREQ)

Base 0x400F.E000
 Offset 0x204
 Type RW, reset 0x0000.0000

	31	30	29	28	27	26	25	24	23	22	21	20	19	18	17	16
	reserved															
Type	RW	RW	RW	RW	RW	RW	RW	RW	RW	RW	RW	RW	RW	RW	RW	RW
Reset	0	0	0	0	0	0	0	0	0	0	0	0	0	0	0	0
	15	14	13	12	11	10	9	8	7	6	5	4	3	2	1	0
	reserved													DESCFG	AESCFG	SHACFG
Type	RW	RW	RW	RW	RW	RW	RW	RW	RW	RW	RW	RW	RW	RW	RW	RW
Reset	0	0	0	0	0	0	0	0	0	0	0	0	0	0	0	0

Bit/Field	Name	Type	Reset	Description
31:3	reserved	RW	0x00000	Software should not rely on the value of a reserved bit. To provide compatibility with future products, the value of a reserved bit should be preserved across a read-modify-write operation.
2	DESCFG	RW	0	DES Clock Gating Request Value Description 0 Request to un-gate clock gating 1 Request to gate the clock.
1	AESCFG	RW	0	AES Clock Gating Request Value Description 0 Request to un-gate clock gating 1 Request to gate the clock.
0	SHACFG	RW	0	SHA/MD5 Clock Gating Request Value Description 0 Request to un-gate clock gating 1 Request to gate the clock.

6 Processor Support and Exception Module

This module is an AHB peripheral that handles system-level Cortex-M4 FPU exceptions. For functions with registers mapped into this aperture, if the function is not available on a device, then all writes to the associated registers are ignored and reads return zeros.

6.1 Functional Description

The System Exception module provides control and status of the system-level interrupts. All the interrupt events are ORed together before being sent to the interrupt controller, so the System Exception module can only generate a single interrupt request to the controller at any given time. Software can service multiple interrupt events in a single interrupt service routine by reading the **System Exception Masked Interrupt Status (SYSEXC MIS)** register. The interrupt events that can trigger a controller-level interrupt are defined in the **System Exception Interrupt Mask (SYSEXC IM)** register by setting the corresponding interrupt mask bits. If interrupts are not used, the raw interrupt status is always visible via the **System Exception Raw Interrupt Status (SYSEXC RIS)** register. Interrupts are always cleared (for both the **SYSEXC MIS** and **SYSEXC RIS** registers) by writing a 1 to the corresponding bit in the **System Exception Interrupt Clear (SYSEXC IC)** register.

6.2 Register Map

Table 6-1 on page 531 lists the System Exception module registers. The offset listed is a hexadecimal increment to the register's address, relative to the System Exception base address of 0x400F.9000.

Note: Spaces in the System Exception register space that are not used are reserved for future or internal use. Software should not modify any reserved memory address.

Table 6-1. System Exception Register Map

Offset	Name	Type	Reset	Description	See page
0x000	SYSEXC RIS	RO	0x0000.0000	System Exception Raw Interrupt Status	532
0x004	SYSEXC IM	RW	0x0000.0000	System Exception Interrupt Mask	534
0x008	SYSEXC MIS	RO	0x0000.0000	System Exception Masked Interrupt Status	536
0x00C	SYSEXC IC	W1C	0x0000.0000	System Exception Interrupt Clear	538

6.3 Register Descriptions

All addresses given are relative to the System Exception base address of 0x400F.9000.

Register 1: System Exception Raw Interrupt Status (SYSEXCRIS), offset 0x000

The **SYSEXCRIS** register is the raw interrupt status register. On a read, this register gives the current raw status value of the corresponding interrupt. A write has no effect.

System Exception Raw Interrupt Status (SYSEXCRIS)

Base 0x400F.9000
 Offset 0x000
 Type RO, reset 0x0000.0000

	31	30	29	28	27	26	25	24	23	22	21	20	19	18	17	16	
	reserved																
Type	RO	RO	RO	RO	RO	RO	RO	RO	RO	RO	RO	RO	RO	RO	RO	RO	
Reset	0	0	0	0	0	0	0	0	0	0	0	0	0	0	0	0	
	15	14	13	12	11	10	9	8	7	6	5	4	3	2	1	0	
	reserved											FPIXCRIS	FPOFCRIS	FPUFCRIS	FPIOCRIS	FPDZCRIS	FPIDCRIS
Type	RO	RO	RO	RO	RO	RO	RO	RO	RO	RO	RO	RO	RO	RO	RO	RO	
Reset	0	0	0	0	0	0	0	0	0	0	0	0	0	0	0	0	

Bit/Field	Name	Type	Reset	Description
31:6	reserved	RO	0x0000.00	Software should not rely on the value of a reserved bit. To provide compatibility with future products, the value of a reserved bit should be preserved across a read-modify-write operation.
5	FPIXCRIS	RO	0	<p>Floating-Point Inexact Exception Raw Interrupt Status</p> <p>Value Description</p> <p>0 No interrupt</p> <p>1 A floating-point inexact exception has occurred.</p> <p>This bit is cleared by writing a 1 to the IXCIC bit in the SYSEXCIC register.</p>
4	FPOFCRIS	RO	0	<p>Floating-Point Overflow Exception Raw Interrupt Status</p> <p>Value Description</p> <p>0 No interrupt</p> <p>1 A floating-point overflow exception has occurred.</p> <p>This bit is cleared by writing a 1 to the OFCIC bit in the SYSEXCIC register.</p>
3	FPUFCRIS	RO	0	<p>Floating-Point Underflow Exception Raw Interrupt Status</p> <p>Value Description</p> <p>0 No interrupt</p> <p>1 A floating-point underflow exception has occurred.</p> <p>This bit is cleared by writing a 1 to the UFCIC bit in the SYSEXCIC register.</p>

Bit/Field	Name	Type	Reset	Description
2	FPIOCRIS	RO	0	<p>Floating-Point Invalid Operation Raw Interrupt Status</p> <p>Value Description</p> <p>0 No interrupt</p> <p>1 A floating-point invalid operation exception has occurred.</p> <p>This bit is cleared by writing a 1 to the IOCIC bit in the SYSEXCIC register.</p>
1	FPDZCRIS	RO	0	<p>Floating-Point Divide By 0 Exception Raw Interrupt Status</p> <p>Value Description</p> <p>0 No interrupt</p> <p>1 A floating-point divide by 0 exception has occurred.</p> <p>This bit is cleared by writing a 1 to the DZCIC bit in the SYSEXCIC register.</p>
0	FPIDCRIS	RO	0	<p>Floating-Point Input Denormal Exception Raw Interrupt Status</p> <p>Value Description</p> <p>0 No interrupt</p> <p>1 A floating-point input denormal exception has occurred.</p> <p>This bit is cleared by writing a 1 to the IDCIC bit in the SYSEXCIC register.</p>

Register 2: System Exception Interrupt Mask (SYSEXCIM), offset 0x004

The **SYSEXCIM** register is the interrupt mask set/clear register.

On a read, this register gives the current value of the mask on the relevant interrupt. Setting a bit allows the corresponding raw interrupt signal to be routed to the interrupt controller. Clearing a bit prevents the raw interrupt signal from being sent to the interrupt controller.

System Exception Interrupt Mask (SYSEXCIM)

Base 0x400F.9000
 Offset 0x004
 Type RW, reset 0x0000.0000

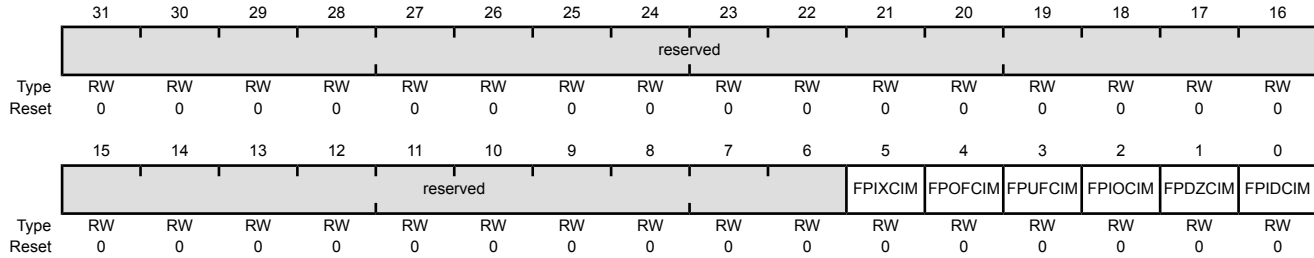

Bit/Field	Name	Type	Reset	Description
31:6	reserved	RW	0x0000.00	Software should not rely on the value of a reserved bit. To provide compatibility with future products, the value of a reserved bit should be preserved across a read-modify-write operation.
5	FPIXCIM	RW	0	Floating-Point Inexact Exception Interrupt Mask Value Description 0 The FPIXCRIS interrupt is suppressed and not sent to the interrupt controller. 1 An interrupt is sent to the interrupt controller when the FPIXCRIS bit in the SYSEXCIM register is set.
4	FPOFCIM	RW	0	Floating-Point Overflow Exception Interrupt Mask Value Description 0 The FPOFCRIS interrupt is suppressed and not sent to the interrupt controller. 1 An interrupt is sent to the interrupt controller when the FPOFCRIS bit in the SYSEXCIM register is set.
3	FPUFCIM	RW	0	Floating-Point Underflow Exception Interrupt Mask Value Description 0 The FPUFCRIS interrupt is suppressed and not sent to the interrupt controller. 1 An interrupt is sent to the interrupt controller when the FPUFCRIS bit in the SYSEXCIM register is set.

Bit/Field	Name	Type	Reset	Description
2	FPIOCIM	RW	0	<p>Floating-Point Invalid Operation Interrupt Mask</p> <p>Value Description</p> <p>0 The <code>FPIOCRIS</code> interrupt is suppressed and not sent to the interrupt controller.</p> <p>1 An interrupt is sent to the interrupt controller when the <code>FPIOCRIS</code> bit in the SYSEXCRIS register is set.</p>
1	FPDZCIM	RW	0	<p>Floating-Point Divide By 0 Exception Interrupt Mask</p> <p>Value Description</p> <p>0 The <code>FPDZCRIS</code> interrupt is suppressed and not sent to the interrupt controller.</p> <p>1 An interrupt is sent to the interrupt controller when the <code>FPDZCRIS</code> bit in the SYSEXCRIS register is set.</p>
0	FPIDCIM	RW	0	<p>Floating-Point Input Denormal Exception Interrupt Mask</p> <p>Value Description</p> <p>0 The <code>FPIDCRIS</code> interrupt is suppressed and not sent to the interrupt controller.</p> <p>1 An interrupt is sent to the interrupt controller when the <code>FPIDCRIS</code> bit in the SYSEXCRIS register is set.</p>

Register 3: System Exception Masked Interrupt Status (SYSEXC MIS), offset 0x008

The **SYSEXC MIS** register is the masked interrupt status register. On a read, this register gives the current masked status value of the corresponding interrupt. A write has no effect.

System Exception Masked Interrupt Status (SYSEXC MIS)

Base 0x400F.9000
 Offset 0x008
 Type RO, reset 0x0000.0000

	31	30	29	28	27	26	25	24	23	22	21	20	19	18	17	16	
	reserved																
Type	RO	RO	RO	RO	RO	RO	RO	RO	RO	RO	RO	RO	RO	RO	RO	RO	
Reset	0	0	0	0	0	0	0	0	0	0	0	0	0	0	0	0	
	15	14	13	12	11	10	9	8	7	6	5	4	3	2	1	0	
	reserved											FPIXCMIS	FPOFCMIS	FPUFCMIS	FPIOCMIS	FPDZCMIS	FPIDCMIS
Type	RO	RO	RO	RO	RO	RO	RO	RO	RO	RO	RO	RO	RO	RO	RO	RO	
Reset	0	0	0	0	0	0	0	0	0	0	0	0	0	0	0	0	

Bit/Field	Name	Type	Reset	Description
31:6	reserved	RO	0x0000.00	Software should not rely on the value of a reserved bit. To provide compatibility with future products, the value of a reserved bit should be preserved across a read-modify-write operation.
5	FPIXCMIS	RO	0	Floating-Point Inexact Exception Masked Interrupt Status Value Description 0 An interrupt has not occurred or is masked. 1 An unmasked interrupt was signaled due to an inexact exception. This bit is cleared by writing a 1 to the FPIXCMIS bit in the SYSEXCIC register.
4	FPOFCMIS	RO	0	Floating-Point Overflow Exception Masked Interrupt Status Value Description 0 An interrupt has not occurred or is masked. 1 An unmasked interrupt was signaled due to an overflow exception. This bit is cleared by writing a 1 to the FPOFCMIS bit in the SYSEXCIC register.
3	FPUFCMIS	RO	0	Floating-Point Underflow Exception Masked Interrupt Status Value Description 0 An interrupt has not occurred or is masked. 1 An unmasked interrupt was signaled due to an underflow exception. This bit is cleared by writing a 1 to the FPUFCMIS bit in the SYSEXCIC register.

Bit/Field	Name	Type	Reset	Description
2	FPIOCMIS	RO	0	<p>Floating-Point Invalid Operation Masked Interrupt Status</p> <p>Value Description</p> <p>0 An interrupt has not occurred or is masked.</p> <p>1 An unmasked interrupt was signaled due to an invalid operation.</p> <p>This bit is cleared by writing a 1 to the FPIOCIC bit in the SYSEXCIC register.</p>
1	FPDZCMIS	RO	0	<p>Floating-Point Divide By 0 Exception Masked Interrupt Status</p> <p>Value Description</p> <p>0 An interrupt has not occurred or is masked.</p> <p>1 An unmasked interrupt was signaled due to a divide by 0 exception.</p> <p>This bit is cleared by writing a 1 to the FPDZCIC bit in the SYSEXCIC register.</p>
0	FPIDCMIS	RO	0	<p>Floating-Point Input Denormal Exception Masked Interrupt Status</p> <p>Value Description</p> <p>0 An interrupt has not occurred or is masked.</p> <p>1 An unmasked interrupt was signaled due to an input denormal exception.</p> <p>This bit is cleared by writing a 1 to the FPIDCIC bit in the SYSEXCIC register.</p>

Register 4: System Exception Interrupt Clear (SYSEXCIC), offset 0x00C

The **SYSEXCIC** register is the interrupt clear register. On a write of 1, the corresponding interrupt (both raw interrupt and masked interrupt, if enabled) is cleared. A write of 0 has no effect.

System Exception Interrupt Clear (SYSEXCIC)

Base 0x400F.9000
 Offset 0x00C
 Type W1C, reset 0x0000.0000



Bit/Field	Name	Type	Reset	Description
31:6	reserved	W1C	0x0000.00	Software should not rely on the value of a reserved bit. To provide compatibility with future products, the value of a reserved bit should be preserved across a read-modify-write operation.
5	FPIXCIC	W1C	0	Floating-Point Inexact Exception Interrupt Clear Writing a 1 to this bit clears the FPIXCRIS bit in the SYSEXCRCRIS register and the FPIXCMIS bit in the SYSEXCRCMIS register.
4	FPOFCIC	W1C	0	Floating-Point Overflow Exception Interrupt Clear Writing a 1 to this bit clears the FPOFCRIS bit in the SYSEXCRCRIS register and the FPOFCMIS bit in the SYSEXCRCMIS register.
3	FPUFCIC	W1C	0	Floating-Point Underflow Exception Interrupt Clear Writing a 1 to this bit clears the FPUFCRIS bit in the SYSEXCRCRIS register and the FPUFCMIS bit in the SYSEXCRCMIS register.
2	FPIOCIC	W1C	0	Floating-Point Invalid Operation Interrupt Clear Writing a 1 to this bit clears the FPIOCRIS bit in the SYSEXCRCRIS register and the FPIOCMIS bit in the SYSEXCRCMIS register.
1	FPDZCIC	W1C	0	Floating-Point Divide By 0 Exception Interrupt Clear Writing a 1 to this bit clears the FPDZCRIS bit in the SYSEXCRCRIS register and the FPDZCMIS bit in the SYSEXCRCMIS register.
0	FPIDCIC	W1C	0	Floating-Point Input Denormal Exception Interrupt Clear Writing a 1 to this bit clears the FPIDCRIS bit in the SYSEXCRCRIS register and the FPIDCMIS bit in the SYSEXCRCMIS register.

7 Hibernation Module

The Hibernation Module manages removal and restoration of power to provide a means for reducing system power consumption. When the processor and peripherals are idle, power can be completely removed with only the Hibernation module remaining powered. Power can be restored based on an external signal or at a certain time using the built-in Real-Time Clock (RTC). The Hibernation module can be independently supplied from an external battery or an auxiliary power supply.

The Hibernation also integrates a tamper module which provides mechanisms to detect, respond to, and log system tampering events. The Tamper module is designed to be low power and operate from either a battery or the MCU I/O voltage supply.

The Hibernation module has the following features:

- 32-bit real-time seconds counter (RTC) with 1/32,768 second resolution and a 15-bit sub-seconds counter
 - 32-bit RTC seconds match register and a 15-bit sub seconds match for timed wake-up and interrupt generation with 1/32,768 second resolution
 - RTC predivider trim for making fine adjustments to the clock rate
- Hardware Calendar Function
 - Year, Month, Day, Day of Week, Hours, Minutes, Seconds
 - Four-year leap compensation
 - 24-hour or AM/PM configuration
- Two mechanisms for power control
 - System power control using discrete external regulator
 - On-chip power control using internal switches under register control
- V_{DD} supplies power when valid, even if $V_{BAT} > V_{DD}$
- Dedicated pin for waking using an external signal
- Capability to configure external reset (\overline{RST}) pin and/or up to four GPIO port pins as wake source, with programmable wake level
- Tamper Functionality
 - Support for four tamper inputs
 - Configurable level, weak pull-up, and glitch filter
 - Configurable tamper event response
 - Logging of up to four tamper events
 - Optional BBRAM erase on tamper detection
 - Tamper wake from hibernate capability

- Hibernation clock input failure detect with a switch to the internal oscillator on detection
- RTC operational and hibernation memory valid as long as V_{DD} or V_{BAT} is valid
- Low-battery detection, signaling, and interrupt generation, with optional wake on low battery
- GPIO pin state can be retained during hibernation
- Clock source from an internal low frequency oscillator (HIB LFIOOSC) or a 32.768-kHz external crystal or oscillator
- Sixteen 32-bit words of battery-backed memory to save state during hibernation
- Programmable interrupts for:
 - RTC match
 - External wake
 - Low battery

7.1 Block Diagram

Figure 7-1. Hibernation Module Block Diagram

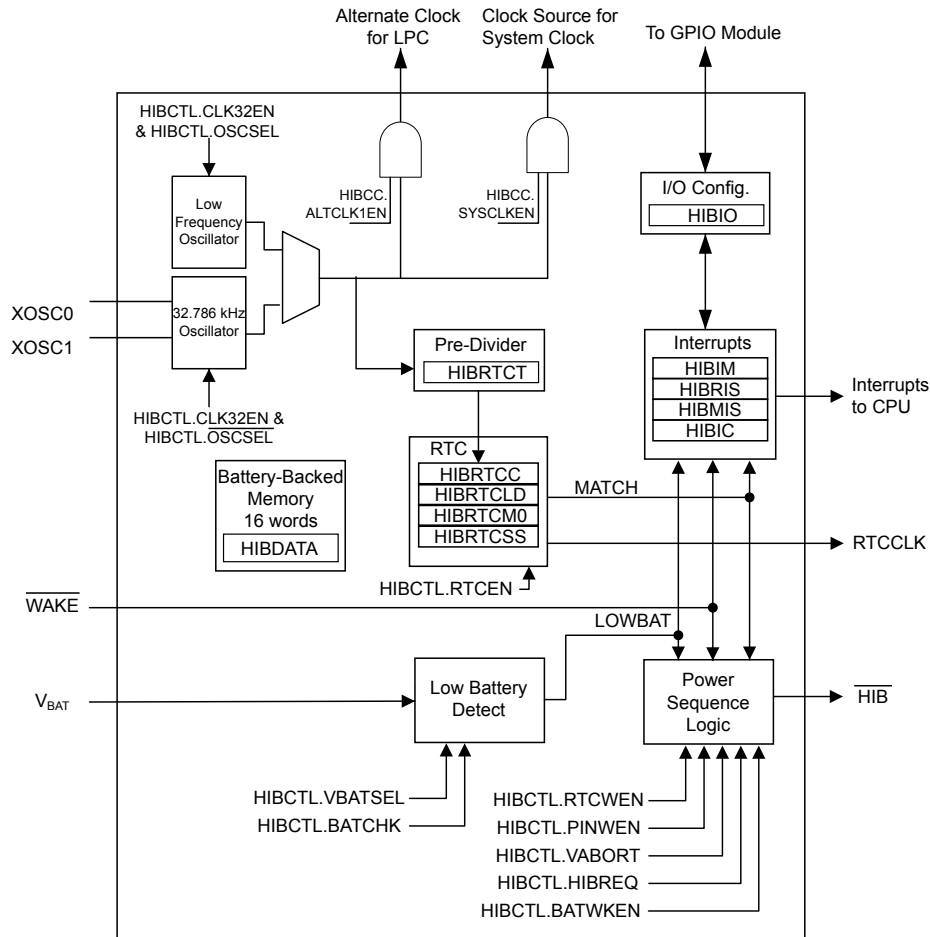

Note: References to alternate clock to LPC only apply to devices which have LPC.

7.2 Signal Description

The following table lists the external signals of the Hibernation module and describes the function of each.

The **RTCCLK** and **TMPR[3:0]** signals are alternate functions for a GPIO signal and defaults to be a GPIO signal at reset. The column in the table below titled "Pin Mux/Pin Assignment" lists the GPIO pin placement for the **RTCCLK** and **TMPR[3:0]** signals. The number in parentheses is the encoding that must be programmed into the **PMC_n** field in the **GPIO Port Control (GPIOCTL)** register (page 795) to assign each signal to its specified GPIO port pin. In addition, the **AFSEL** bit in the **GPIO Alternate Function Select (GPIOAFSEL)** register (page 778) should be set to choose the proper HIB function. For more information on configuring GPIOs, see "General-Purpose Input/Outputs (GPIOs)" on page 750.

The remaining signals have a fixed pin assignment and function.

Note: In addition to the Hibernation signals that are part of the Hibernation Module, GPIO pins K[7:4] can be configured as external wake sources. Refer to “Waking from Hibernate” on page 554 for more information.

Note: Port pins $PM[7:4]$ operate as Fast GPIO pads but support only 2-, 4-, 6-, and 8-mA drive capability. 10- and 12-mA drive are not supported. All standard GPIO register controls, except for the **GPIODR12R** register, apply to these port pins. Refer to “General-Purpose Input/Outputs (GPIOs)” on page 750 and “Recommended GPIO Operating Characteristics” on page 1944 for more information.

Table 7-1. Hibernate Signals (128TQFP)

Pin Name	Pin Number	Pin Mux / Pin Assignment	Pin Type	Buffer Type	Description
\overline{HTB}	65	fixed	O	TTL	An output that indicates the processor is in Hibernate mode.
RTCCLK	24 60 104	PC5 (7) PK7 (5) PP3 (7)	O	TTL	Buffered version of the Hibernation module's 32.768-kHz clock. This signal is not output when the part is in Hibernate mode and before being configured after power-on reset.
TMPR0	71	PM7	I/O	TTL	Tamper signal 0.
TMPR1	72	PM6	I/O	TTL	Tamper signal 1.
TMPR2	73	PM5	I/O	TTL	Tamper signal 2.
TMPR3	74	PM4	I/O	TTL	Tamper signal 3.
VBAT	68	fixed	-	Power	Power source for the Hibernation module. It is normally connected to the positive terminal of a battery and serves as the battery backup/Hibernation module power-source supply.
\overline{WAKE}	64	fixed	I	TTL	An external input that brings the processor out of Hibernate mode when asserted.
XOSC0	66	fixed	I	Analog	Hibernation module oscillator crystal input or an external clock reference input. Note that this is either a crystal or a 32.768-kHz oscillator for the Hibernation module RTC.
XOSC1	67	fixed	O	Analog	Hibernation module oscillator crystal output. Leave unconnected when using a single-ended clock source.

7.3 Functional Description

The Hibernation module provides two mechanisms for power control:

- The first mechanism uses internal switches to control power to the Cortex-M4F as well as to most analog and digital functions while retaining I/O pin power (VDD3ON mode).
- The second mechanism controls the power to the microcontroller with a control signal (\overline{HTB}) that signals an external voltage regulator to turn on or off.

The Hibernation module power source is supplied by V_{DD} as long as it is within a valid range, even if $V_{BAT} > V_{DD}$. The Hibernation module also has an independent clock source to maintain a real-time clock (RTC) when the system clock is powered down. Hibernate mode can be entered through one of two ways:

- The user initiates hibernation by setting the `HIBREQ` bit in the **Hibernation Control (HIBCTL)** register
- Power is arbitrarily removed from V_{DD} while a valid V_{BAT} is applied

Once in hibernation, the module signals an external voltage regulator to turn the power back on when an external pin (`WAKE`, `RST` or a wake-enabled GPIO pin) is asserted or when the internal RTC reaches a certain value. The Hibernation module can also detect when the battery voltage is low and optionally prevent hibernation or wake from hibernation when the battery voltage falls below a certain threshold. Note that multiple wake sources can be configured at the same time to generate a wake signal such that any of them can wake the module.

When waking from hibernation, the `HIB` signal is deasserted. The return of V_{DD} causes a POR to be executed. The time from when the `WAKE` signal is asserted to when code begins execution is equal to the wake-up time ($t_{WAKE_TO_HIB}$) plus the power-on reset time (T_{POR}).

7.3.1 Register Access Timing

Because the Hibernation module has an independent clocking domain, hibernation registers must be written only with a timing gap between accesses. The delay time is $t_{HIB_REG_ACCESS}$, therefore software must guarantee that this delay is inserted between back-to-back writes to Hibernation registers or between a write followed by a read. The `WC` interrupt in the **HIBMIS** register can be used to notify the application when the Hibernation modules registers can be accessed. Alternatively, software may make use of the `WRC` bit in the **Hibernation Control (HIBCTL)** register to ensure that the required timing gap has elapsed. This bit is cleared on a write operation and set once the write completes, indicating to software that another write or read may be started safely. Software should poll **HIBCTL** for `WRC=1` prior to accessing any hibernation register.

Back-to-back reads from Hibernation module registers have no timing restrictions. Reads are performed at the full peripheral clock rate.

7.3.2 Hibernation Clock Source

The HIB module can be clocked by one of three different clock sources:

- A 32.768-kHz oscillator
- An external 32.768-kHz clock source
- An internal low frequency oscillator (HIB LFIOSC)

Table 7-2 on page 543 summarizes the encodings for the bits in the **HIBCTL** register that are required for each clock source to be enabled. Note that `CLK32EN` must be set for any Hibernation clock source to be valid. The Hibernation module is not enabled until the `CLK32EN` bit is set. The HIB clock source is the source of the RTC Oscillator (RTCOS), which can be selected as the system clock source by programming a 0x4 in the `OSCSRC` field of the **Run and Sleep Mode Configuration (RSCLKCFG)** register in the System Control Module. Please refer to “System Control” on page 227 for more information.

Table 7-2. HIB Clock Source Configurations

HIB Clock Source	CLK32EN	OSCSSEL	OSCBYP
32.768 kHz Oscillator	1	0	0
External 32.768-kHz Clock Source	1	0	1

Table 7-2. HIB Clock Source Configurations (continued)

HIB Clock Source	CLK32EN	OSCSSEL	OSCBYP
Low-frequency internal oscillator (HIB LFIOSC) ^a	1	1	0

a. The frequency can have wide variations; refer to “Hibernation Clock Source Specifications” on page 1961 for more details.

To use an external crystal, a 32.768-kHz crystal is connected to the `XOSC0` and `XOSC1` pins. Alternatively, a 32.768-kHz oscillator can be connected to the `XOSC0` pin, leaving `XOSC1` unconnected. Care must be taken that the voltage amplitude of the 32.768-kHz oscillator is less than V_{BAT} , otherwise, the Hibernation module may draw power from the oscillator and not V_{BAT} during hibernation. See Figure 7-2 on page 545 and Figure 7-3 on page 545.

Alternatively, a low frequency oscillator source (HIB LFIOSC) present in the Hibernation module can be a clock source. (The frequency can have wide variations; refer to “Hibernation Clock Source Specifications” on page 1961 for more details.) The intent of this source is to provide an internal low power clock source to enable the use of the asynchronous pin wakes and memory storage without the requirement of an external crystal. To enable the HIB LFIOSC to be the clock source for the Hibernation module, both the `OSCSSEL` bit and the `CLK32EN` bit in the **Hibernation Control (HIBCTL)** register must be set.

Note: The HIB low-frequency oscillator (HIB LFIOSC) has a wide frequency variation, therefore the RTC is not accurate when using this clock source. It is not recommended to use the HIB LFIOSC as an RTC clock source.

The Hibernation module is enabled by setting the `CLK32EN` bit of the **HIBCTL** register. The `CLK32EN` bit must be set before accessing any other Hibernation module register. The type of clock source used for the HIB module is selected by setting the `OSCSSEL` and `OSCBYP` bit of the **HIBCTL** register. If the internal low frequency precision oscillator is used as the clock source, the `OSCSSEL` bit should be set to a 1 at the same time the `CLK32EN` bit is set. If a crystal is used for the clock source, the software must leave a delay of t_{HIBOSC_START} after writing to the `CLK32EN` bit and before any other accesses to the Hibernation module registers. The delay allows the crystal to power up and stabilize. If an external oscillator is used for the clock source, no delay is needed. When using an external clock source, the `OSCBYP` bit in the **HIBCTL** register should be set. When using a crystal clock source, the `GNDX` pin should be connected to digital ground along with the crystal load capacitors, as shown in Figure 7-2 on page 545. When using an external clock source, the `GNDX` pin should be connected to digital ground.

Note: In the figures below the parameters R_{BAT} and C_{BAT} have recommended values of $51\Omega \pm 5\%$ and $0.1\mu F \pm 5\%$, respectively. See “Hibernation Module” on page 1969 for more information.

Figure 7-2. Using a Crystal as the Hibernation Clock Source with a Single Battery Source

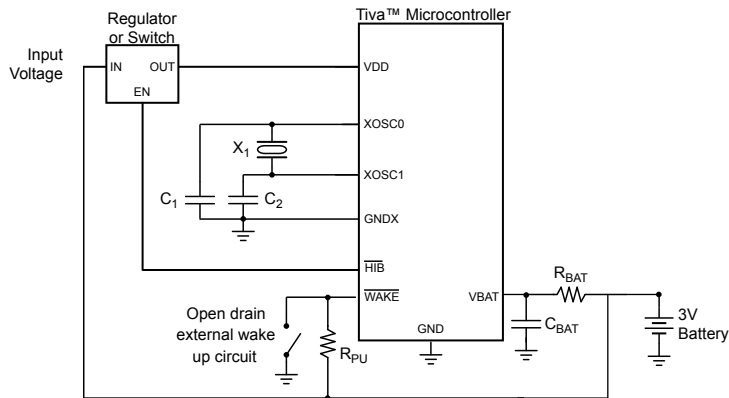

Note: Some devices may not supply the GNDX signal. If GNDX is absent, the crystal load capacitors can be tied to GND externally. See “Signal Tables” on page 1896 for pins specific to your device.

X_1 = Crystal frequency is f_{XOSC_XTAL} .

$C_{1,2}$ = Capacitor value derived from crystal vendor load capacitance specifications.

R_{PU} = Pull-up resistor is 200 k Ω

R_{BAT} = 51 Ω \pm 5%

C_{BAT} = 0.1 μ F \pm 20%

See “Hibernation Clock Source Specifications” on page 1961 for specific parameter values.

Figure 7-3. Using a Dedicated Oscillator as the Hibernation Clock Source with VDD3ON Mode

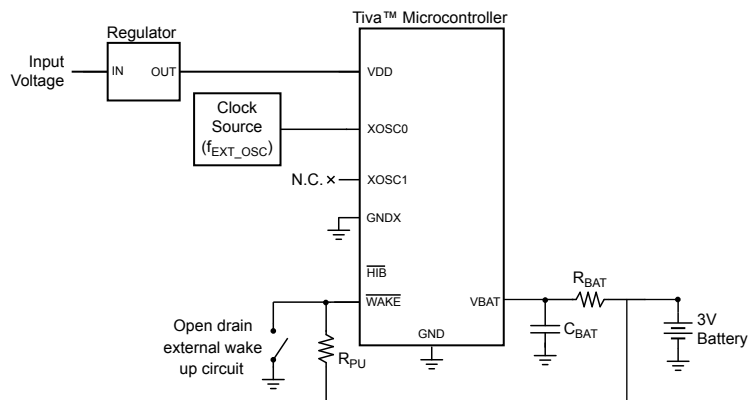

Note: Some devices may not supply a GNDX signal. See “Signal Tables” on page 1896 for pins specific to your device.

R_{PU} = Pull-up resistor is 1 M Ω

R_{BAT} = 51 Ω \pm 5%

C_{BAT} = 0.1 μ F \pm 20%

7.3.2.1 Hibernate Clock Output RTCOSC

The clock source that is configured as the HIB clock has the option of becoming an internal output, RTCOSC, and being selected as the clock source for the system clock. To enable RTCOSC as a system clock source, the `SYSCLKEN` bit must be set in the **Hibernate Clock Control (HIBCC)** register.

7.3.3 System Implementation

Several different system configurations are possible when using the Hibernation module:

- Using a single battery source, where the battery provides both V_{DD} and V_{BAT} , as shown in Figure 7-2 on page 545.
- Using the VDD3ON mode, where V_{DD} continues to be powered in hibernation, allowing the GPIO pins to retain their states, as shown in Figure 7-3 on page 545. In this mode, V_{DDC} is powered off internally. In VDD3ON mode, the `RETCLR` bit in the **HIBCTL** register must be set so that after power is reapplied, GPIO retention is held until software clears the bit. GPIO retention is released when software writes a 0 to the `RETCLR` bit.
- Using separate sources for V_{DD} and V_{BAT} . In this mode, additional circuitry is required for system start-up without a battery or with a depleted battery.
- Using a regulator to provide both V_{DD} and V_{BAT} with a switch enabled by \overline{HIB} to remove V_{DD} during hibernation as shown in Figure 7-4 on page 546.

Figure 7-4. Using a Regulator for Both V_{DD} and V_{BAT}

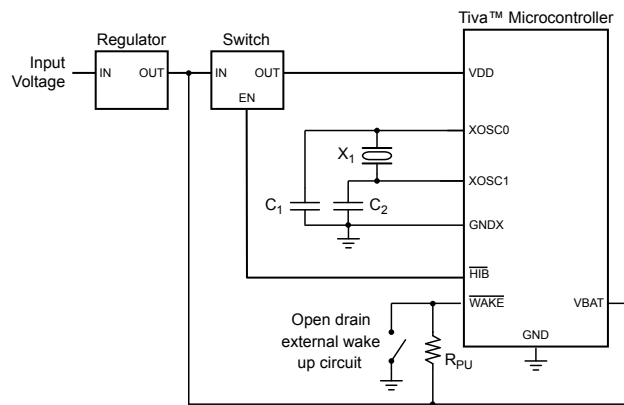

Note: Some devices may not supply a `GNDX` signal. See “Signal Tables” on page 1896 for pins specific to your device.

Adding external capacitance to the V_{BAT} supply reduces the accuracy of the low-battery measurement and should be avoided if possible. The diagrams referenced in this section only show the connection to the Hibernation pins and not to the full system.

If the application does not require the use of the Hibernation module, refer to “Connections for Unused Signals” on page 1940. In this situation, the `HIB` bit in the **Hibernation Run Mode Clock Gating Control (RCGCHIB)** register must be cleared, disabling the system clock to the Hibernation module and Hibernation module registers are not accessible.

7.3.4 Battery Management

Important: System-level factors may affect the accuracy of the low-battery detect circuit. The designer should consider battery type, discharge characteristics, and a test load during battery voltage measurements.

The Hibernation module can be independently powered by a battery or an auxiliary power source using the V_{BAT} pin. The module can monitor the voltage level of the battery and detect when the voltage drops below V_{LOWBAT} . The voltage threshold can be between 1.9 V and 2.5 V and is configured using the V_{BATSEL} field in the **HIBCTL** register. The module can also be configured so that it does not go into Hibernate mode if the battery voltage drops below this threshold. In addition, battery voltage is monitored while in hibernation, and the microcontroller can be configured to wake from hibernation if the battery voltage goes below the threshold using the $BATWKEN$ bit in the **HIBCTL** register.

The Hibernation module is designed to detect a low-battery condition and set the $LOWBAT$ bit of the **Hibernation Raw Interrupt Status (HIBRIS)** register when this occurs. If the V_{ABORT} bit in the **HIBCTL** register is also set, then the module is prevented from entering Hibernate mode when a low-battery is detected. The module can also be configured to generate an interrupt for the low-battery condition (see “Interrupts and Status” on page 556).

7.3.5 Real-Time Clock

The RTC module is designed to keep wall time. The RTC can operate in seconds counter mode or calendar mode. A 32.768 kHz clock source along with a 15-bit predivider reduces the clock to 1 Hz. The 1 Hz clock is used to increment the 32-bit counter and keep track of seconds. In calendar mode, registers are provided which support the tracking of date, month, year and day-of-week. A match register can be configured to interrupt or wake the system from hibernate. In addition, a software trim register is implemented to allow the user to compensate for oscillator inaccuracies using software.

7.3.5.1 RTC Counter - Seconds/Subseconds Mode

The clock signal to the RTC is provided by either of the 32.768-kHz clock sources available to the Hibernation module. The **Hibernation RTC Counter (HIBRTCC)** register displays the seconds value. The **Hibernation RTC Sub Seconds register (HIBRTCSS)** is provided for additional time resolution of an application requiring less than one-second divisions.

The RTC is enabled by setting the $RTCEN$ bit of the **HIBCTL** register. The $RTCEN$ bit is also used along with the $CALEN$ bit in the **Hibernation Calendar Control (HIBCALCTL)** register to enable the calendar. Thus, if the calendar is enabled, the RTC registers, **HIBRTCC**, **HIBRTCSS**, **HIBRTCMO** and **HIBRTCLD**, cannot be used. The RTC counter and sub-seconds counters begin counting immediately once $RTCEN$ is set. Both counters count up. The RTC continues counting as long as the RTC is enabled and a valid V_{BAT} is present, regardless of whether V_{DD} is present or if the device is in hibernation.

The **HIBRTCC** register is set by writing the **Hibernation RTC Load (HIBRTCLD)** register. A write to the **HIBRTCLD** register clears the 15-bit sub-seconds counter field, $RTCSSC$, in the **HIBRTCSS** register. To ensure a valid read of the RTC value, the **HIBRTCC** register should be read first, followed by a read of the $RTCSSC$ field in the **HIBRTCSS** register and then a re-read of the **HIBRTCC** register. If the two values for the **HIBRTCC** are equal, the read is valid. By following this procedure, errors in the application caused by the **HIBRTCC** register rolling over by a count of 1 during a read of the $RTCSSC$ field are prevented. The RTC can be configured to generate an alarm by setting the $RTCALO$ bit in the **HIBIM** register. When an RTC match occurs, an interrupt is generated and displayed in the **HIBRIS** register. Refer to “RTC Match - Seconds/Subseconds Mode” on page 548 for more information.

If the RTC is enabled, only a cold POR, where both V_{BAT} and V_{DD} are removed, resets the RTC registers. If any other reset occurs while the RTC is enabled, such as an external \overline{RST} assertion or BOR reset, the RTC is not reset. The RTC registers can be reset under any type of system reset as long as the RTC, external wake pins and tamper pins are not enabled.

A buffered version of the 32.768-kHz signal Hibernate clock source is available on the $RTCCLK$ signal output, which is muxed with a GPIO pin. The $RTCCLK$ signal can be the external 32.786-kHz clock source or the HIB LFIOSC depending on the value of the $OSCSEL$ bit in the **HIBCTL** register. See “Signal Description” on page 541 or pin mux information and “General-Purpose Input/Outputs (GPIOs)” on page 750 for additional details on initialization and configuration of this signal. The pin does not output $RTCCLK$ when Hibernate mode is active or before the $RTCCLK$ GPIO digital function has been selected through the **GPIO Digital Enable (GPIODEN)** register in the GPIO module. This includes selecting the $RTCCLK$ signal as an output source in the **GPIO Port Control (GPIOPCTL)** register and setting the $SYSCLKEN$ bit within the **Hibernate Clock Control (HIBCC)** register.

Note: The HIB low-frequency oscillator (HIB LFIOSC) has a wide frequency variation, therefore the RTC is not accurate when using this clock source. In addition, the $RTCCLK$ signal may not meet the specification shown in Table 30-30 on page 1969.

7.3.5.2 RTC Match - Seconds/Subseconds Mode

The Hibernation module includes a 32-bit match register, **HIBRTCM0**, which is compared to the value of the RTC 32-bit counter, **HIBRTCC**. The match functionality also extends to the sub-seconds counter. The 15-bit field ($RTCSSM$) in the **HIBRTCSS** register is compared to the value of the 15-bit sub-seconds counter. When a match occurs, the $RTCALT0$ bit is set in the **HIBRIS** register. For applications using Hibernate mode, the processor can be programmed to wake from Hibernate mode by setting the $RTCWEN$ bit in the **HIBCTL** register. The processor can also be programmed to generate an interrupt to the interrupt controller by setting the $RTCALT0$ bit in the **HIBIM** register.

The match interrupt generation takes priority over an interrupt clear. Therefore, writes to the $RTCALT0$ bit in the **Hibernation Interrupt Clear (HIBIC)** register do not clear the $RTCALT0$ bit if the **HIBRTCC** value and the **HIBRTCM0** value are equal. There are several methodologies to avoid this occurrence, such as writing a new value to the **HIBRTCLD** register prior to writing the **HIBIC** to clear the $RTCALT0$. Another example, would be to disable the RTC and re-enable the RTC by clearing and setting the $RTCEN$ bit in the **HIBCTL** register.

Note: A Hibernate request made while a match event is valid causes the module to immediately wake up. This occurs when the $RTCWEN$ bit is set and the $RTCALT0$ bit in the **HIBRIS** register is set at the same time the $HIBREQ$ bit in the **HIBCTL** register is written to a 1. This can be avoided by clearing the $RTCALT0$ bit in the **HIBRIS** register by writing a 1 to the corresponding bit in the **HIBIC** register before setting the $HIBREQ$ bit. Another example would be to disable the RTC and re-enable the RTC by clearing and setting the $RTCEN$ bit in the **HIBCTL** register.

7.3.5.3 RTC Calendar

The RTC Calendar function is selected by setting the $CALEN$ bit in the **HIB Calendar Control (HIBCALCTL)** register. In this mode, six 32-bit registers provide the read (**HIBCAL0/1**), match (**HIBCALM0/1**), and load (**HIBCALLD0/1**) interface. The standard RTC registers: **HIBRTCC**, **HIBRTCLD**, **HIBRTCSS**, and **HIBRTCM0** are disabled when the calendar function is enabled and read back as all 0s in this mode. In addition, writes have no effect on these registers when the calendar function is enabled.

The **Hibernation Calendar n (HIBCALn)**, **Hibernation Calendar Match (HIBCALMn)** and **Hibernation Calendar Load (HIBCALLDn)** register fields are written or stored in hexadecimal.

When reading the **Hibernation Calendar n (HIBCALn)** registers, the status of the `VALID` bit in the **HIBCAL0/1** register must be checked to ensure the registers are in sync before reading.

The calendar function will keep track of the following:

- Seconds (0-59 seconds)
- Minutes (0-59 minutes)
- Hours (0-23 or 0-11 hours with an AM/PM option)
- Day of the week (0-6)
- Day of the month (1-31 days)
- Month (1-12 months)
- Year (00-99 years)

The hours may be reported with AM/PM or 24-hour based on the `CAL24` bit in the **HIBCALCTL** register. The leap year compensation is handled within the calendar function. The number of days in February are adjusted to 29 whenever the year is divisible by four.

RTC Calendar Match

The HIB Calendar Match function can be used to generate an interrupt on a match of seconds, minutes, hours, and day of month. The day of the week, year and month are not included in the match function. To ignore a match function for the hours, minutes, or seconds, set each of the upper two bits to 1 in the respective fields of the **HIBCALMn** register. To ignore the day of the month, set the `DOM` field to all zeros in the **HIBCALM1** register. If a match occurs in any field, the `RTCALT0` bit is set in the **HIBRIS** register.

7.3.5.4 RTC Trim

The RTC counting rate can be adjusted to compensate for inaccuracies in the clock source by using the predivider trim register, **HIBRTCT**. This register has a nominal value of 0x7FFF, and is used for one second out of every 64 seconds in RTC counter mode, when bits [5:0] in the **HIBRTCC** register change from 0x00 to 0x01, to divide the input clock. Trim is applied every 60 seconds in calendar mode. This configuration allows the software to make fine corrections to the clock rate by adjusting the predivider trim register up or down from 0x7FFF. The predivider trim should be adjusted up from 0x7FFF in order to slow down the RTC rate and down from 0x7FFF in order to speed up the RTC rate.

Care must be taken when using trim values that are near to the sub seconds match value in the **HIBRTCSS** register. It is possible when using trim values above 0x7FFF to receive two match interrupts for the same counter value. In addition, it is possible when using trim values below 0x7FFF to miss a match interrupt.

In the case of a trim value above 0x7FFF, when the `RTCSSC` value in the **HIBRTCSS** register reaches 0x7FFF, the `RTCC` value increments from 0x0 to 0x1 while the `RTCSSC` value is decreased by the trim amount. The `RTCSSC` value is counted up again to 0x7FFF before rolling over to 0x0 to begin counting up again. If the match value is within this range, the match interrupt is triggered twice. For example, as shown in Figure 7-5 on page 550, if the match interrupt was configured with `RTCM0=0x1` and `RTCSSM=0x7FFD`, two interrupts would be triggered.

Figure 7-5. Counter Behavior with a TRIM Value of 0x8002

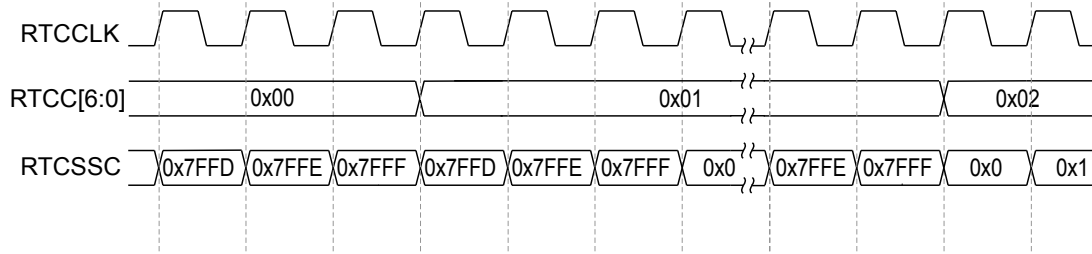

In the case of a trim value below 0x7FFF, the RTCSSC value is advanced from 0x7FFF to the trim value while the RTCC value is incremented from 0x0 to 0x1. If the match value is within that range, the match interrupt is not triggered. For example, as shown in Figure 7-6 on page 550, if the match interrupt was configured with RTCM0=0x1 and RTCSSM=0x2, an interrupt would never be triggered.

Figure 7-6. Counter Behavior with a TRIM Value of 0x7FFC

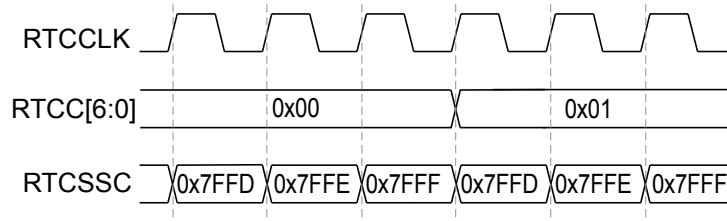

7.3.6 Tamper

The Tamper module provides a user with mechanisms to detect, respond to, and log system tampering events. The Tamper module is designed to be low power and operate either from a battery or the MCU I/O voltage supply. This module is a sub-module of the Hibernate module.

7.3.6.1 Tamper Block Diagram

Figure 7-7 on page 550 shows the Tamper block diagram.

Figure 7-7. Tamper Block Diagram

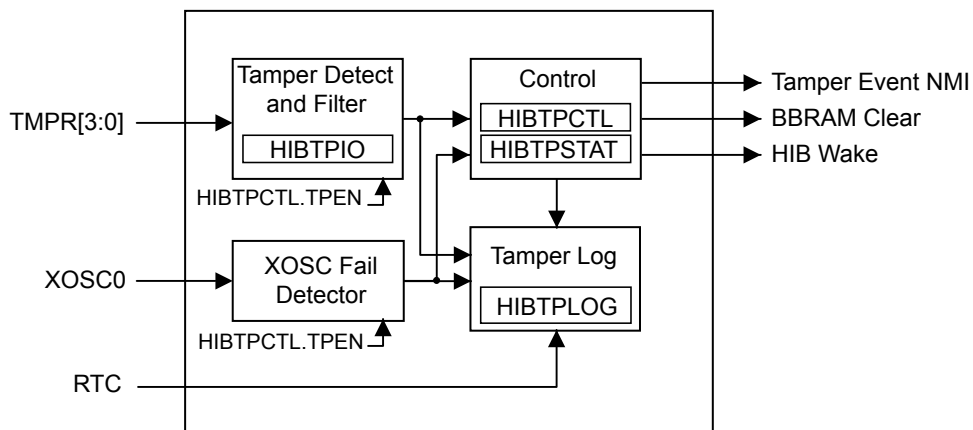

7.3.6.2 Functional Description

The Tamper module provides mechanisms to detect, respond, and log system tamper events. A tamper event is detected by state transitions on up to four GPIOs. The module may respond to a tamper event by clearing all or part of the hibernate module memory, generating a tamper event signal to the System Control module. The event will also be logged with a RTC time stamp to allow for tamper investigation.

Tamper Detection

Qualified tamper events are detected through an $XOSC_n$ pin failure or through tamper I/O level matches which pass through a glitch filter. Tamper I/O pad events are detected by comparing the level on a tamper I/O pad with an expected value. The tamper I/O is sampled using the hibernate clock source and when the glitch filtering is enabled, must be stable for about 100 ms. This provides debounce filtering of a breakaway switch as a results of a drop impact. The tamper module contains one long glitch filter and one short glitch filter which uses an OR of the inputs as shown in Figure 7-8 on page 551. This implies if two Tamper inputs are asserted and one deasserts, the glitch filter runs to timeout or until the second Tamper input is deasserted. The glitch filter or tamper logging logic does not re-trigger if the tamper event match continues. The glitch filter resets on the deassertion of the tamper conditions or when a qualified tamper event is logged.

If the $XOSC_n$ pins are enabled for use with the Hibernation module and subsequently fail, a tamper event is detected and is indicated by the *STATE* field in the **HIB Tamper Status (HIBTPSTAT)** register. In addition, the *XOSCST* and *XOSCFAIL* bits can be read for further details on the external oscillator source state.

Figure 7-8. Tamper Pad with Glitch Filtering

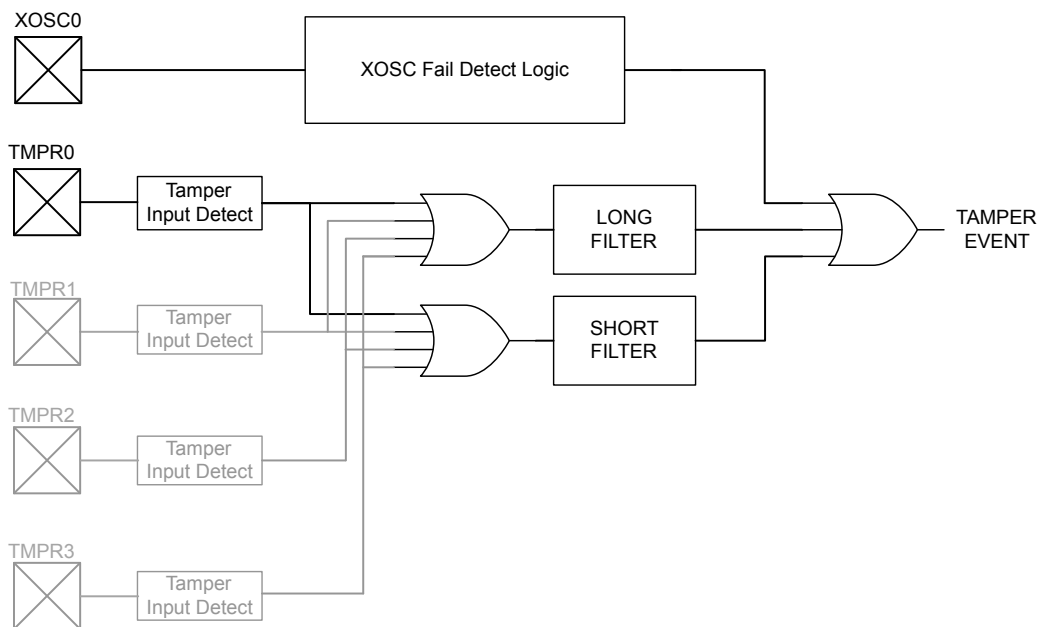

Tamper Event Responses

There are many responses to a tamper event including clearing some or all of Hibernate memory and generating a tamper signal to the System Control Module. The descriptions of the possible event responses follows.

- Tamper Register Status

The tamper status is indicated by the `STATE` bit field of the **HIB Tamper Status (HIBTPSTAT)** register. The register bits are reset to 0x0 on cold POR. When the tamper I/O is enabled/configured, the `STATE` field shows 0x1. The `STATE` field is set to 0x2 when a tamper event is detected. The software may reset the trigger source and the `STATE` field by writing to the `TPCLR` bit in the **HIBTPCTL** register.

- System Event Response

When a tamper event is detected, an NMI is generated. The NMI handler is responsible for performing any other system responses, including a simulate POR. If the tamper event was an XOSC fail condition, the part switches to the HIB LFIOSC. Once XOSC is stable, the XOSC may be enabled as the clock source once again.

- Hibernate Memory Clearing

On a tamper event, software has the option to clear all, the upper half, lower half, or none of the Hibernate memory. The feature is controlled through the `MEMCLR` field of the **HIBTPCTL** register.

- Wake from Hibernate

A tamper event will assert a wake event to the MCU if the `WAKE` bit in the **HIBTPCTL** register is set.

Tamper Event Logging

Up to four tamper events are stored in **HIB Tamper Log n (HIBTPLOGn)** registers within the Hibernate module. When a tamper event occurs the following status is logged:

- The RTC seconds or calendar values of year, minutes, day of month, hours and seconds in the **HIBTPLOG0/2/4/6** registers

Note: 24-hour mode must be used if RTC calendar mode is enabled. This mode is selected by setting the `CAL24` bit in **HIB Calendar Control (HIBCALCTL)** register.

- The tamper status of the `TMPRn` pins and the `XOSCn` pins in the **HIBTPLOG1/3/5** registers. The **HIBTPLOG7** register captures the OR of all events occurring after the 3rd event is logged in the **HIBTPLOG5** register.

On the assertion of a qualified tamper event (rising edge) on any of the `TMPRn` pins or an XOSC failure signal, the current status of all tamper inputs are logged in the **HIBTPLOGn** register.

Clearing a Tamper Event

After a tamper event, the **HIB Tamper Log (HIBTPLOGn)** registers and the NMI to the processor may be cleared by writing a 1 to the `TPCLR` bit in the **HIBTPCTL** register. This clear status is reflected by the `STATE` bit in the **HIBTPSTAT** register changing from 0x2 back to a 0x1. If the source of the tamper event comes from an XOSC failure, the clearing of a tamper event is delayed while the clock is switched to LFIOSC. The NMI interrupt handler may access the module immediately, but should read the **HIBTPLOGn** registers before issuing a tamper clear in the **HIBTPCTL** register.

Note: The **HIBTPLOG7** register is sticky and is only cleared by a Hibernate module reset.

Tamper I/O Control

Up to four tamper I/Os are available. These signals are individually enabled and the detection level can be configured per pin. Enabling the tamper IO will override all settings made in the GPIO module. Each tamper IO has a weak pull-up.

Tamper Clocking

The Hibernate clock is the clock source for the Tamper module. When an external oscillator is used and tamper is enabled, the external oscillator is monitored by the Tamper module. If the external oscillator stops for any reason, the `XOSCFAIL` bit is set in the `HIBTPSTAT` register and the Hibernate clock source is switched to the HIB LFIOSC immediately. When the `XOSCST` bit in the `HIBTPSTAT` register is 0, indicating the external oscillator is active, a 1 can be written to the `XOSCFAIL` bit to clear it and re-enable the external 32.768-kHz oscillator.

Note: Because the HIB LFIOSC has a wide frequency variation, it should not be configured as the HIB clock source when accurate monitoring of the tamper logs are important.

Tamper Resets

The Tamper module uses the resets from the Hibernate module.

Important: The Hibernation module registers are reset under two conditions:

1. Any type of system reset (if the `RTCEN` and the `PINWEN` bits in the `HIBCTL` register are clear and the `TPEN` bit in the `HIBTPCTL` register is clear).
2. A cold POR occurs when both the V_{DD} and V_{BAT} supplies are removed.

Any other reset condition is ignored by the Hibernation module.

7.3.7 Battery-Backed Memory

The Hibernation module contains 16 32-bit words of memory that are powered from the battery or an auxiliary power supply and therefore retained during hibernation. The processor software can save state information in this memory prior to hibernation and recover the state upon waking. To access the upper eight words of memory, the processor must be in privilege mode. Refer to “Processor Mode and Privilege Levels for Software Execution” on page 90 for more information about processor privilege mode. The battery-backed memory can be accessed through the `HIBDATA` registers. If both V_{DD} and V_{BAT} are removed, the contents of the `HIBDATA` registers are not retained.

7.3.8 Power Control Using \overline{HIB}

Important: The Hibernation Module requires special system implementation considerations when using \overline{HIB} to control power, as it is intended to power-down all other sections of the microcontroller. All system signals and power supplies that connect to the chip must be driven to 0 V or powered down with the same regulator controlled by \overline{HIB} .

The Hibernation module controls power to the microcontroller through the use of the \overline{HIB} pin which is intended to be connected to the enable signal of the external regulator(s) providing 3.3 V to the microcontroller and other circuits. When the \overline{HIB} signal is asserted by the Hibernation module, the external regulator is turned off and no longer powers the microcontroller and any parts of the system that are powered by the regulator. The Hibernation module remains powered from the V_{BAT} supply until a Wake event. Power to the microcontroller is restored by deasserting the \overline{HIB} signal, which causes the external regulator to turn power back on to the chip.

7.3.9 Power Control Using VDD3ON Mode

The Hibernation module may also be configured to cut power to all internal modules during Hibernate mode. While in this state, if `VDD3ON` is set in the **HIBCTL** register, all pins are held in the state they were in prior to entering hibernation. For example, inputs remain inputs; outputs driven high remain driven high, and so on. There are important procedural and functional items to note when in VDD3ON mode:

- JTAG Ports C[0] - C[3] do not retain their state in Hibernate VDD3ON mode.
- If GPIO pins K[7:4] are not used as a wake source, they should not be left floating. An internal pull-up resistor may be configured by the application before entering Hibernate mode by programming the **GPIO Pull-Up Select (GPIOPUR)** register in the GPIO module.
- In the VDD3ON mode, the regulator should maintain 3.3 V power to the microcontroller during Hibernate. GPIO retention is disabled when the `RETCLR` bit is cleared in the **HIBCTL** register.
- When entering hibernation in VDD3ON mode, the supply rails to the Ethernet resistors R1, R2, R3, R4 found in Figure 23-13 on page 1588 must be switched off.

7.3.10 Initiating Hibernate

Hibernate mode is initiated when the `HIBREQ` bit of the **HIBCTL** register is set. If a wake-up condition has not been configured using the `PINWEN` or `RTCWEN` bits in the **HIBCTL** register, the hibernation request is ignored. In addition, if the battery voltage is below the threshold voltage defined by the `VBATSEL` field in the **HIBCTL** register, the hibernation request is ignored.

7.3.11 Waking from Hibernate

The Hibernation module can be configured to wake from Hibernate mode if any of the following are enabled:

- External $\overline{\text{WAKE}}$
- External $\overline{\text{RST}}$
- GPIO K[7:4]
- Tamper `TMPR[3:0]`
- Tamper XOSC failure

The Hibernation module can also be configured to wake from hibernate when the following events occur:

- RTC match wake event
- Low Battery wake event

The external $\overline{\text{WAKE}}$ pin is enabled by setting the `PINWEN` bit in the **HIBCTL** register. The external $\overline{\text{WAKE}}$ pin can generate an interrupt by programming the `EXTWEN` bit in the **Hibernation Interrupt Mask (HIBIM)** register.

Note: If an external $\overline{\text{WAKE}}$ signal is asserted, the application is responsible for clearing the signal source once the `EXTWEN` bit has been registered in the **Hibernation Raw Interrupt Status (HIBRIS)** register.

To use the $\overline{\text{RST}}$ pin as a wake source, the `WURSTEN` bit must be set in the **Hibernate I/O Configuration (HIBIO)** register and the `WUUNLK` bit must be set in the same register.

To enable any of the assigned GPIO pins as a wake source, the `WUUNLK` bit must be set in the **HIBIO** register and the wake configuration must be programmed through the **GPIOWAKEPEN** and **GPIOWAKELVL** registers in the GPIO module. Please refer to “General-Purpose Input/Outputs (GPIOs)” on page 750 for more information on programming the GPIOs.

Note: The $\overline{\text{RST}}$ pin and GPIO wake sources are cleared by a write to either or both the `RSTWK` and `PADIOWK` bits. This clears the source of interrupts for `RSTWK`, `PADIOWK` and the **GPIOWAKESTAT** register.

`TMPR[3:0]` are enabled by setting the appropriate `ENn` bits the **Tamper IO Control and Status (HIBTPIO)** register. The **HIBTPIO** register overrides the GPIO port configuration registers. By setting the `WAKE` bit in the **Tamper Control (HIBTPCTL)** register, a tamper event can cause a wake from Hibernate. If a tamper event occurs, the time of the event and the status of the tamper pins are logged in the **Tamper Log (HIBTPLOG)** register.

By setting the `RTCWEN` bit in the **HIBCTL** register a wake from hibernate can occur when the value of the **HIBRTCC** register matches the value of the **HIBRTCM0** register and the value of the `RTCSSC` field matches the `RTCSSM` field in the **HIBRTCSS** register.

To allow a wake from Hibernate on a low battery event, the `BATWKEN` bit in the **HIBCTL** register must be set. In this configuration, the battery voltage is checked every 512 seconds while in hibernation. If the voltage is below the level specified by the `VBATSEL` field, the `LOWBAT` interrupt is set in the **HIBRIS** register.

Upon external wake-up, external reset, tamper event, or RTC match, the Hibernation module delays coming out of hibernation until V_{DD} is above the minimum specified voltage, see Table 30-6 on page 1944.

When the Hibernation module wakes, the microcontroller performs a normal power-on reset. The normal power-on reset does not reset the Hibernation module or Tamper module, but does reset the rest of the microcontroller. Software can detect that the power-on was due to a wake from hibernation by examining the raw interrupt status register (see “Interrupts and Status” on page 556) and by looking for state data in the battery-backed memory (see “Battery-Backed Memory” on page 553).

7.3.12 Arbitrary Power Removal

The microcontroller goes into hibernation if V_{DD} is arbitrarily removed when the `CLK32EN` bit is set and any of the following bits are set:

- `TPEN` bit in the **HIBTPCTL** register
- `PINWEN` bit in the **HIBCTL** register
- `RTCEN` bit in the **HIBCTL** register

The microcontroller wakes from hibernation when power is reapplied.

If the `CLK32EN` bit is set but the `TPEN`, `PINWEN`, and `RTCEN` bits are all clear, the microcontroller still goes into hibernation if power is removed; however, when V_{DD} is reapplied, the MCU executes a cold POR and the Hibernation module is reset. If the `CLK32EN` bit is not set and V_{DD} is arbitrarily removed, the part is simply powered off and executes a cold POR when power is reapplied.

If V_{DD} is arbitrarily removed while a Flash memory or **HIBDATA** register write operation is in progress, the write operation must be retried after V_{DD} is reapplied.

7.3.13 Interrupts and Status

The Hibernation module can generate interrupts when the following conditions occur:

- Assertion of \overline{WAKE} pin
- RTC match
- Low battery detected
- Write complete/capable
- Assertion of an external \overline{RESET} pin
- Assertion of an external wake-enabled GPIO pin (port K[7:4])

All of the interrupts except for the tamper signals are ORed together before being sent to the interrupt controller, so the Hibernation module can only generate a single interrupt request to the controller at any given time. The software interrupt handler can service multiple interrupt events by reading the **Hibernation Masked Interrupt Status (HIBMIS)** register. Software can also read the status of the Hibernation module at any time by reading the **HIBRIS** register which shows all of the pending events. This register can be used after waking from hibernation to see if a wake condition was caused by one of the events above or by a power loss.

The \overline{WAKE} pin can generate interrupts in Run, Sleep and Deep Sleep Mode. The events that can trigger an interrupt are configured by setting the appropriate bits in the **Hibernation Interrupt Mask (HIBIM)** register. Pending interrupts can be cleared by writing the corresponding bit in the **Hibernation Interrupt Clear (HIBIC)** register.

7.4 Initialization and Configuration

The Hibernation module has several different configurations. The following sections show the recommended programming sequence for various scenarios. Because the Hibernation module runs at a low frequency and is asynchronous to the rest of the microcontroller, which is run off the system clock, software must allow a delay of $t_{HIB_REG_ACCESS}$ after writes to registers (see “Register Access Timing” on page 543). The WC interrupt in the **HIBMIS** register can be used to notify the application when the Hibernation modules registers can be accessed.

7.4.1 Initialization

The Hibernation module comes out of reset with the system clock enabled to the module, but if the system clock to the module has been disabled, then it must be re-enabled, even if the RTC feature is not used. See page 394.

If a 32.768-kHz crystal is used as the Hibernation module clock source, perform the following steps:

1. Write 0x0000.0010 to the **HIBIM** register to enable the WC interrupt.
2. Write 0x40 to the **HIBCTL** register at offset 0x10 to enable the oscillator input.
3. Wait until the WC interrupt in the **HIBMIS** register has been triggered before performing any other operations with the Hibernation module.

If a 32.768-kHz single-ended oscillator is used as the Hibernation module clock source, then perform the following steps:

1. Write 0x0000.0010 to the **HIBIM** register to enable the **wc** interrupt.
2. Write 0x0001.0040 to the **HIBCTL** register at offset 0x10 to enable the oscillator input and bypass the on-chip oscillator.
3. Wait until the **wc** interrupt in the **HIBMIS** register has been triggered before performing any other operations with the Hibernation module.

If the internal low frequency oscillator is used as the Hibernation module clock source, then perform the following steps:

1. Write 0x0000.0010 to the **HIBIM** register to enable the **wc** interrupt.
2. Write 0x0008.0040 to the **HIBCTL** register at offset 0x10 to enable the internal low frequency oscillator.
3. Wait until the **wc** interrupt in the **HIBMIS** register has been triggered before performing any other operations with the Hibernation module.

The above steps are only necessary when the entire system is initialized for the first time. If the microcontroller has been in hibernation, then the Hibernation module has already been powered up and the above steps are not necessary. The software can detect that the Hibernation module and clock are already powered by examining the **CLK32EN** bit of the **HIBCTL** register.

7.4.2 RTC Match Functionality (No Hibernation)

Use the following steps to implement the RTC match functionality of the Hibernation module:

1. Write 0x0000.0040 to the **HIBCTL** register at offset 0x010 to enable 32.768-kHz Hibernation oscillator.
2. Write the required RTC match value to the **HIBRTCM0** register at offset 0x004 and the **RTCSSM** field in the **HIBRTCSS** register at offset 0x028.
3. Write the required RTC load value to the **HIBRTCLD** register at offset 0x00C.
4. Set the required RTC match interrupt mask in the **RTCALTO** in the **HIBIM** register at offset 0x014.
5. Write 0x0000.0041 to the **HIBCTL** register at offset 0x010 to enable the RTC to begin counting.

7.4.3 RTC Match/Wake-Up from Hibernation

Use the following steps to implement the RTC match and wake-up functionality of the Hibernation module:

1. Write 0x0000.0040 to the **HIBCTL** register at offset 0x010 to enable 32.768-kHz Hibernation oscillator.
2. Write the required RTC match value to the **HIBRTCM0** register at offset 0x004 and the **RTCSSM** field in the **HIBRTCSS** register at offset 0x028.
3. Write the required RTC load value to the **HIBRTCLD** register at offset 0x00C. This write causes the 15-bit sub seconds counter to be cleared.

4. Write any data to be retained during hibernation to the **HIBDATA** register at offsets 0x030-0x06F.
5. Set the RTC Match Wake-Up and start the hibernation sequence by writing 0x0000.004B to the **HIBCTL** register at offset 0x010.

7.4.4 External Wake-Up from Hibernation

Use the following steps to implement the Hibernation module with the external $\overline{\text{WAKE}}$ pin as the wake-up source for the microcontroller:

1. Write 0x0000.0040 to the **HIBCTL** register at offset 0x010 to enable 32.768-kHz Hibernation oscillator.
2. Write any data to be retained during hibernation to the **HIBDATA** register at offsets 0x030-0x06F.
3. Enable the external wake and start the hibernation sequence by writing 0x0000.0052 to the **HIBCTL** register at offset 0x010.

Use the following steps to program the external $\overline{\text{RESET}}$ pin as the wake source for the microcontroller:

1. Write 0x0000.0040 to the **HIBCTL** register at offset 0x010 to enable 32.768-kHz Hibernation oscillator.
2. Write any data to be retained during hibernation to the **HIBDATA** register at offsets 0x030-0x06F.
3. Enable the external $\overline{\text{RESET}}$ pin as a wake source by writing a 0x0000.0011 to the **HIBIO** register at offset 0x02C.
4. When the **IOWRC** bit in the **HIBIO** register is read as 1, clear the **WUUNLK** bit in the **HIBIO** register to lock the current pad configuration so that any other writes to the **WURSTEN** bit in the **HIBIO** register will be ignored.
5. The hibernation sequence may be initiated by writing 0x4000.0152 to the **HIBCTL** register. Note that when using $\overline{\text{RESET}}$, the user must enable VDD3ON mode and set the **RETCLR** bit in the **HIBCTL** register.

Use the following steps to program GPIO port K pins K[7:4] as the wake source for the microcontroller:

1. Write 0x0000.0040 to the **HIBCTL** register at offset 0x010 to enable 32.768-kHz Hibernation oscillator.
2. Write any data to be retained during hibernation to the **HIBDATA** register at offsets 0x030-0x06F.
3. Configure the **GPIOWAKEPEN** and **GPIOWAKELVL** registers at offsets 0x540 and 0x544 in the GPIO module. Enable the I/O wake pad configuration by writing 0x0000.0001 to the **HIBIO** register at offset 0x010.
4. When the **IOWRC** bit in the **HIBIO** register is read as 1, write 0x0000.0000 to the **HIBIO** register to lock the current pad configuration so that any other writes to the **GPIOWAKEPEN** and **GPIOWAKELVL** register will be ignored.
5. Clear any pending interrupts by writing a 1 to the **PADIOWK** bit in the **HIBIC** register.

6. The hibernation sequence may be initiated by writing 0x4000.0152 to the **HIBCTL** register. Note for Port M external wake, the user must enable VDD3ON mode and set the **RETCLR** bit in the **HIBCTL** register.

7.4.5 RTC or External Wake-Up from Hibernation

1. Write 0x0000.0040 to the **HIBCTL** register at offset 0x010 to enable 32.768-kHz Hibernation oscillator.
2. Write the required RTC match value to the **HIBRTCM0** register at offset 0x004 and the **RTCSSM** field in the **HIBRTCSS** register at offset 0x028.
3. Write the required RTC load value to the **HIBRTCLD** register at offset 0x00C. This write causes the 15-bit sub seconds counter to be cleared.
4. Write any data to be retained during hibernation to the **HIBDATA** register at offsets 0x030-0x06F.
5. Set the RTC Match/External Wake-Up and start the hibernation sequence by writing 0x0000.005B to the **HIBCTL** register at offset 0x010.

7.4.6 Tamper Initialization

Use the following steps to configure the Tamper module to interrupt the processor when a **TMPR** signal has triggered:

Note: Unlike other functions, the Tamper pins do not need to be configured for the GPIO in the **GPIOAFSEL** register. The **Tamper IO Control and Status (HIBTPIO)** register overrides configurations made to the GPIO module.

1. Write 0x0000.0041 to the **HIBCTL** register at offset 0x010 to enable the 32.768-kHz Hiberate oscillator and enable the RTC.
2. Enable the four Tamper I/O to trigger on the a high state on any of the pins by writing 0x0F0F.0F0F to the **HIBTPIO** register at offset 0x410.
3. Write 0x0000.0001 to the **HIBTPCTL** register to enable the tamper.

Note: Once tamper is enabled, the following **HIBCTL** register bits are locked and cannot be modified:

- OSCSEL
- OSCDRV
- OSCBYP
- VDD3ON
- CLK32EN
- RTCEN

7.5 Register Map

Table 7-3 on page 560 lists the Hibernation registers. All addresses given are relative to the Hibernation Module base address at 0x400F.C000. Note that the system clock to the Hibernation module must be enabled before the registers can be programmed (see page 394). There must be a delay of 3 system clocks after the Hibernation module clock is enabled before any Hibernation module registers

are accessed. In addition, the `CLK32EN` bit in the **HIBCTL** register must be set before accessing any other Hibernation module register.

Note: Except for the **HIBIO** and a portion of the **HIBIC** register, all other Hibernation module registers are on the Hibernation module clock domain and have special timing requirements. Software should make use of the `WRC` bit in the **HIBCTL** register to ensure that the required timing gap has elapsed. If the `WRC` bit is clear, any attempted write access is ignored. See “Register Access Timing” on page 543. The **HIBIO** register and bits `RSTWK`, `PADIOWK` and `WC` of the **HIBIC** register do not require waiting for write to complete. Because these registers are clocked by the system clock, writes to these registers/bits are immediate.

Writing to registers other than the **HIBCTL** and **HIBIM** before the `CLK32EN` bit in the **HIBCTL** register has been set may produce unexpected results.

Important: The Hibernation module registers are reset under two conditions:

1. Any type of system reset (if the `RTCEN` and the `PINWEN` bits in the **HIBCTL** register are clear and the `TPEN` bit in the **HIBTPCTL** register is clear).
2. A cold POR occurs when both the V_{DD} and V_{BAT} supplies are removed.

Any other reset condition is ignored by the Hibernation module.

Note that the following registers are only accessed through privileged mode (see “System Control” on page 227 for more details):

- **HIBTPCTL**
- **HIBPTSTAT**
- **HIBTPIO**
- **HIBTPLOG**
- Upper eight words of memory (**HIBDATA** register 0x50 to 0x6F)

Table 7-3. Hibernation Module Register Map

Offset	Name	Type	Reset	Description	See page
0x000	HIBRTCC	RO	0x0000.0000	Hibernation RTC Counter	562
0x004	HIBRTCM0	RW	0xFFFF.FFFF	Hibernation RTC Match 0	563
0x00C	HIBRTCLD	WO	0x0000.0000	Hibernation RTC Load	564
0x010	HIBCTL	RW	0x8000.2000	Hibernation Control	565
0x014	HIBIM	RW	0x0000.0000	Hibernation Interrupt Mask	570
0x018	HIBRIS	RO	0x0000.0000	Hibernation Raw Interrupt Status	572
0x01C	HIBMIS	RO	0x0000.0000	Hibernation Masked Interrupt Status	574
0x020	HIBIC	RW1C	0x0000.0000	Hibernation Interrupt Clear	576
0x024	HIBRTCT	RW	0x0000.7FFF	Hibernation RTC Trim	578
0x028	HIBRTCSS	RW	0x0000.0000	Hibernation RTC Sub Seconds	579

Table 7-3. Hibernation Module Register Map (continued)

Offset	Name	Type	Reset	Description	See page
0x02C	HIBIO	RW	0x8000.0000	Hibernation IO Configuration	580
0x030-0x06F	HIBDATA	RW	-	Hibernation Data	582
0x300	HIBCALCTL	RW	0x0000.0000	Hibernation Calendar Control	583
0x310	HIBCAL0	RO	0x0000.0000	Hibernation Calendar 0	584
0x314	HIBCAL1	RO	0x0000.0000	Hibernation Calendar 1	586
0x320	HIBCALLD0	WO	0x0000.0000	Hibernation Calendar Load 0	588
0x324	HIBCALLD1	WO	0x0000.0000	Hibernation Calendar Load	590
0x330	HIBCALM0	RW	0x0000.0000	Hibernation Calendar Match 0	591
0x334	HIBCALM1	RW	0x0000.0000	Hibernation Calendar Match 1	593
0x360	HIBLOCK	RW	0x0000.0000	Hibernation Lock	594
0x400	HIBTPCTL	RW	0x0000.0000	HIB Tamper Control	595
0x404	HIBTPSTAT	RW1C	0x0000.0000	HIB Tamper Status	597
0x410	HIBTPIO	RW	0x0000.0000	HIB Tamper I/O Control	599
0x4E0	HIBTPLOG0	RO	0x0000.0000	HIB Tamper Log 0	603
0x4E4	HIBTPLOG1	RO	0x0000.0000	HIB Tamper Log 1	604
0x4E8	HIBTPLOG2	RO	0x0000.0000	HIB Tamper Log 2	603
0x4EC	HIBTPLOG3	RO	0x0000.0000	HIB Tamper Log 3	604
0x4F0	HIBTPLOG4	RO	0x0000.0000	HIB Tamper Log 4	603
0x4F4	HIBTPLOG5	RO	0x0000.0000	HIB Tamper Log 5	604
0x4F8	HIBTPLOG6	RO	0x0000.0000	HIB Tamper Log 6	603
0x4FC	HIBTPLOG7	RO	0x0000.0000	HIB Tamper Log 7	604
0xFC0	HIBPP	RO	0x0000.0002	Hibernation Peripheral Properties	606
0xFC8	HIBCC	RW	0x0000.0000	Hibernation Clock Control	607

7.6 Register Descriptions

The remainder of this section lists and describes the Hibernation module registers, in numerical order by address offset.

Register 1: Hibernation RTC Counter (HIBRTCC), offset 0x000

This register is the current 32-bit value of the RTC counter.

The RTC counter consists of a 32-bit seconds counter and a 15-bit sub seconds counter. The RTC counters are reset by the Hibernation module reset. The RTC 32-bit seconds counter can be set by the user using the **HIBRTCLD** register. When the 32-bit seconds counter is set, the 15-bit sub second counter is cleared.

The RTC value can be read by first reading the **HIBRTCC** register, reading the **RTCCSSC** field in the **HIBRTCSS** register, and then rereading the **HIBRTCC** register. If the two values for **HIBRTCC** are equal, the read is valid.

Note: There is a minimum system clock rate of three times the HIB clock rate to properly read the **HIBRTCC** register.

Hibernation RTC Counter (HIBRTCC)

Base 0x400F.C000
 Offset 0x000
 Type RO, reset 0x0000.0000

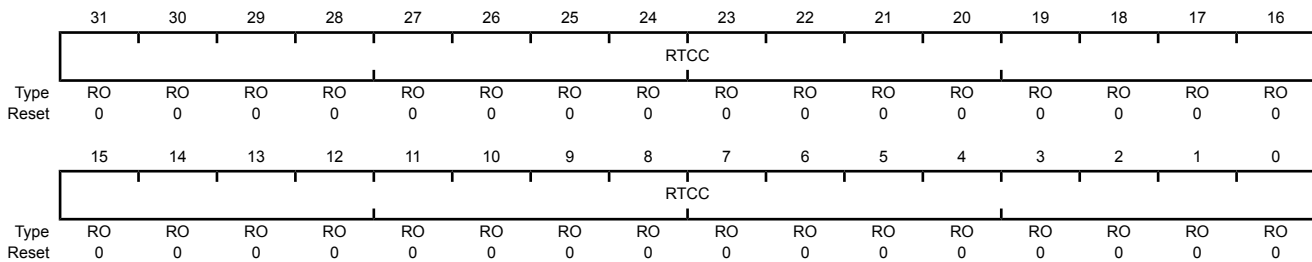

Bit/Field	Name	Type	Reset	Description
31:0	RTCC	RO	0x0000.0000	RTC Counter

A read returns the 32-bit counter value, which represents the seconds elapsed since the RTC was enabled. This register is read-only. To change the value, use the **HIBRTCLD** register.

Register 2: Hibernation RTC Match 0 (HIBRTCM0), offset 0x004

This register is the 32-bit seconds match register for the RTC counter. The 15-bit sub second match value is stored in the reading the `RTCSSC` field in the `HIBRTCSS` register and can be used in conjunction with this register for a more precise time match.

Note: Except for the `HIBIO` and a portion of the `HIBIC` register, all other Hibernation module registers are on the Hibernation module clock domain and have special timing requirements. Software should make use of the `WRC` bit in the `HIBCTL` register to ensure that the required timing gap has elapsed. If the `WRC` bit is clear, any attempted write access is ignored. See “Register Access Timing” on page 543. The `HIBIO` register and bits `RSTWK`, `PADIOWK` and `WC` of the `HIBIC` register do not require waiting for write to complete. Because these registers are clocked by the system clock, writes to these registers/bits are immediate.

Writing to registers other than the `HIBCTL` and `HIBIM` before the `CLK32EN` bit in the `HIBCTL` register has been set may produce unexpected results.

Hibernation RTC Match 0 (HIBRTCM0)

Base 0x400F.C000

Offset 0x004

Type RW, reset 0xFFFF.FFFF

	31	30	29	28	27	26	25	24	23	22	21	20	19	18	17	16
	RTCM0															
Type	RW	RW	RW	RW	RW	RW	RW	RW	RW	RW	RW	RW	RW	RW	RW	RW
Reset	1	1	1	1	1	1	1	1	1	1	1	1	1	1	1	1
	15	14	13	12	11	10	9	8	7	6	5	4	3	2	1	0
	RTCM0															
Type	RW	RW	RW	RW	RW	RW	RW	RW	RW	RW	RW	RW	RW	RW	RW	RW
Reset	1	1	1	1	1	1	1	1	1	1	1	1	1	1	1	1

Bit/Field	Name	Type	Reset	Description
31:0	RTCM0	RW	0xFFFF.FFFF	RTC Match 0 A write loads the value into the RTC match register. A read returns the current match value.

Register 3: Hibernation RTC Load (HIBRTCLD), offset 0x00C

This register is used to load a 32-bit value loaded into the RTC counter. The load occurs immediately upon this register being written. When this register is written, the 15-bit sub seconds counter is also cleared.

Note: This register is protected from errant code by using the **HIBLOCK** register. This register is write-only; any reads to this register read back as zeros.

Note: Except for the **HIBIO** and a portion of the **HIBIC** register, all other Hibernation module registers are on the Hibernation module clock domain and have special timing requirements. Software should make use of the **WRC** bit in the **HIBCTL** register to ensure that the required timing gap has elapsed. If the **WRC** bit is clear, any attempted write access is ignored. See “Register Access Timing” on page 543. The **HIBIO** register and bits **RSTWK**, **PADIOWK** and **WC** of the **HIBIC** register do not require waiting for write to complete. Because these registers are clocked by the system clock, writes to these registers/bits are immediate.

Writing to registers other than the **HIBCTL** and **HIBIM** before the **CLK32EN** bit in the **HIBCTL** register has been set may produce unexpected results.

Hibernation RTC Load (HIBRTCLD)

Base 0x400F.C000
 Offset 0x00C
 Type WO, reset 0x0000.0000

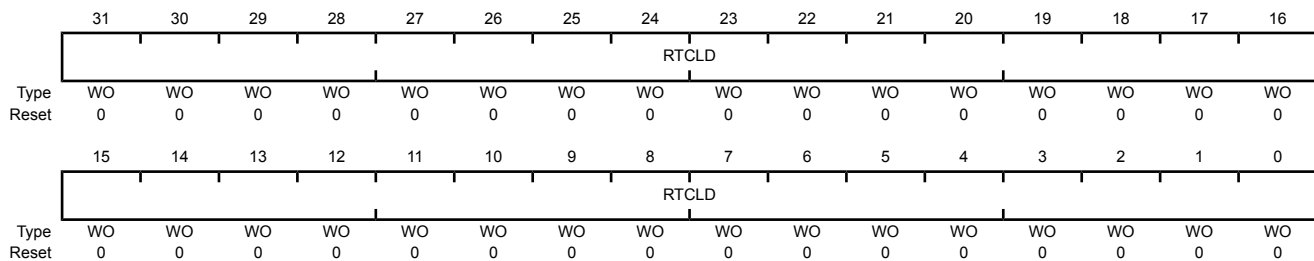

Bit/Field	Name	Type	Reset	Description
31:0	RTCLD	WO	0x0000.0000	RTC Load A write loads the current value into the RTC counter (RTCC). A read returns the 32-bit load value.

Register 4: Hibernation Control (HIBCTL), offset 0x010

This register is the control register for the Hibernation module. This register must be written last before a hibernate event is issued. Writes to other registers after the `HIBREQ` bit is set are not guaranteed to complete before hibernation is entered.

Note: Writes to this register have special timing requirements. Software should make use of the `WRC` bit in the `HIBCTL` register to ensure that the required synchronization has elapsed. While the `WRC` bit is clear, any attempts to write this register are ignored. Reads may occur at any time.

Note that once tamper is enabled, the following `HIBCTL` clock configuration bits and bus write stall bit are locked and cannot be modified:

- `OSCSEL`
- `OSCDRV`
- `OSCBYP`
- `VDD3ON`
- `CLK32EN`
- `RTCEN`

Hibernation Control (HIBCTL)

Base 0x400F.C000
Offset 0x010
Type RW, reset 0x8000.2000

	31	30	29	28	27	26	25	24	23	22	21	20	19	18	17	16
	WRC	RETCLR	reserved										OSCSEL	reserved	OSCDRV	OSCBYP
Type	RO	RW	RO	RO	RO	RO	RO	RO	RO	RO	RO	RO	RW	RO	RW	RW
Reset	1	0	0	0	0	0	0	0	0	0	0	0	0	0	0	0
	15	14	13	12	11	10	9	8	7	6	5	4	3	2	1	0
	reserved	VBATSEL	reserved		BATCHK	BATWKEN	VDD3ON	VABORT	CLK32EN	reserved	PINWEN	RTCWEN	reserved	HIBREQ	RTCEN	
Type	RO	RW	RW	RO	RO	RW	RW	RW	RW	RO	RW	RW	RO	RW	RW	
Reset	0	0	1	0	0	0	0	0	0	0	0	0	0	0	0	

Bit/Field	Name	Type	Reset	Description
31	WRC	RO	1	Write Complete/Capable

Value Description

- | | |
|---|--|
| 0 | The interface is processing a prior write and is busy. Any write operation that is attempted while <code>WRC</code> is 0 results in undetermined behavior. |
| 1 | The interface is ready to accept a write. |

Software must poll this bit between write requests and defer writes until `WRC=1` to ensure proper operation. An interrupt can be configured to indicate the `WRC` has completed.

The bit name `WRC` means "Write Complete," which is the normal use of the bit (between write accesses). However, because the bit is set out-of-reset, the name can also mean "Write Capable" which simply indicates that the interface may be written to by software. This difference may be exploited by software at reset time to detect which method of programming is appropriate: 0 = software delay loops required; 1 = `WRC` paced available.

Bit/Field	Name	Type	Reset	Description
30	RETCLR	RW	0	<p>GPIO Retention/Clear</p> <p>This bit is used when the VDD3ON bit is set. This bit must be set when entering the hibernate state when the VDD3ON bit is set. This does not affect behavior when VDD3ON is clear.</p> <p>Note: This bit must be set when enabling VDD3ON mode.</p> <p>Value Description</p> <p>0 GPIO retention is released when power is reapplied. The GPIOs are initialized to default values.</p> <p>1 GPIO retention set until software clears this bit.</p>
29:20	reserved	RO	0	<p>Software should not rely on the value of a reserved bit. To provide compatibility with future products, the value of a reserved bit should be preserved across a read-modify-write operation.</p>
19	OSCSEL	RW	0	<p>Oscillator Select</p> <p>This bit is used to select between the use of an external 32.768-kHz source or the HIB internal low frequency oscillator (HIB LFIOSC).</p> <p>Note: To enable the HIB LFIOSC, <code>CLK32EN</code> must be programmed to 1 at the same time the <code>OSCSEL</code> bit is set. Thus the HIBCTL register should be written with 0x0008.0040</p> <p>Value Description</p> <p>0 External 32.786-kHz clock source is enabled.</p> <p>1 HIB Low frequency oscillator (HIB LFIOSC) is enabled.</p> <p>Note: The HIB low-frequency oscillator has a wide frequency variation, therefore the RTC is not accurate when using this clock source.</p>
18	reserved	RO	0	<p>Software should not rely on the value of a reserved bit. To provide compatibility with future products, the value of a reserved bit should be preserved across a read-modify-write operation.</p>
17	OSCDRV	RW	0	<p>Oscillator Drive Capability</p> <p>This bit is used to compensate for larger or smaller filtering capacitors.</p> <p>Note: This bit is not meant to be changed once the Hibernation oscillator has started. Oscillator stability is not guaranteed if the user changes this value after the oscillator is running.</p> <p>Value Description</p> <p>0 Low drive strength is enabled, 12 pF.</p> <p>1 High drive strength is enabled, 24 pF.</p>
16	OSCBYP	RW	0	<p>Oscillator Bypass</p> <p>Value Description</p> <p>0 The internal 32.768-kHz Hibernation oscillator is enabled. This bit should be cleared when using an external 32.768-kHz crystal.</p> <p>1 The internal 32.768-kHz Hibernation oscillator is disabled and powered down. This bit should be set when using a single-ended oscillator attached to <code>XOSC0</code>.</p>

Bit/Field	Name	Type	Reset	Description										
15	reserved	RO	0	Software should not rely on the value of a reserved bit. To provide compatibility with future products, the value of a reserved bit should be preserved across a read-modify-write operation.										
14:13	VBATSEL	RW	0x1	<p>Select for Low-Battery Comparator</p> <p>This field selects the battery level that is used when checking the battery status. If the battery voltage is below the specified level, the LOWBAT interrupt bit in the HIBRIS register is set.</p> <table border="1"> <thead> <tr> <th>Value</th> <th>Description</th> </tr> </thead> <tbody> <tr> <td>0x0</td> <td>1.9 Volts</td> </tr> <tr> <td>0x1</td> <td>2.1 Volts (default)</td> </tr> <tr> <td>0x2</td> <td>2.3 Volts</td> </tr> <tr> <td>0x3</td> <td>2.5 Volts</td> </tr> </tbody> </table>	Value	Description	0x0	1.9 Volts	0x1	2.1 Volts (default)	0x2	2.3 Volts	0x3	2.5 Volts
Value	Description													
0x0	1.9 Volts													
0x1	2.1 Volts (default)													
0x2	2.3 Volts													
0x3	2.5 Volts													
12:11	reserved	RO	0x0	Software should not rely on the value of a reserved bit. To provide compatibility with future products, the value of a reserved bit should be preserved across a read-modify-write operation.										
10	BATCHK	RW	0	<p>Check Battery Status</p> <table border="1"> <thead> <tr> <th>Value</th> <th>Description</th> </tr> </thead> <tbody> <tr> <td>0</td> <td> <p>When read, indicates that the low-battery comparator cycle is not active.</p> <p>Writing a 0 has no effect.</p> </td> </tr> <tr> <td>1</td> <td> <p>When read, indicates the low-battery comparator cycle has not completed.</p> <p>Setting this bit initiates a low-battery comparator cycle. If the battery voltage is below the level specified by VBATSEL field, the LOWBAT interrupt bit in the HIBRIS register is set. A hibernation request is held off if a battery check is in progress.</p> </td> </tr> </tbody> </table>	Value	Description	0	<p>When read, indicates that the low-battery comparator cycle is not active.</p> <p>Writing a 0 has no effect.</p>	1	<p>When read, indicates the low-battery comparator cycle has not completed.</p> <p>Setting this bit initiates a low-battery comparator cycle. If the battery voltage is below the level specified by VBATSEL field, the LOWBAT interrupt bit in the HIBRIS register is set. A hibernation request is held off if a battery check is in progress.</p>				
Value	Description													
0	<p>When read, indicates that the low-battery comparator cycle is not active.</p> <p>Writing a 0 has no effect.</p>													
1	<p>When read, indicates the low-battery comparator cycle has not completed.</p> <p>Setting this bit initiates a low-battery comparator cycle. If the battery voltage is below the level specified by VBATSEL field, the LOWBAT interrupt bit in the HIBRIS register is set. A hibernation request is held off if a battery check is in progress.</p>													
9	BATWKEN	RW	0	<p>Wake on Low Battery</p> <table border="1"> <thead> <tr> <th>Value</th> <th>Description</th> </tr> </thead> <tbody> <tr> <td>0</td> <td>The battery voltage level is not automatically checked. Low battery voltage does not cause the microcontroller to wake from hibernation.</td> </tr> <tr> <td>1</td> <td> <p>In RTC mode, when this bit is set, the battery voltage level is checked every 512 seconds while in hibernation.</p> <p>In calendar mode, the battery voltage is checked on minutes divisible by 8 while in hibernation.</p> <p>If the voltage is below the level specified by VBATSEL field, the microcontroller wakes from hibernation and the LOWBAT interrupt bit in the HIBRIS register is set.</p> </td> </tr> </tbody> </table>	Value	Description	0	The battery voltage level is not automatically checked. Low battery voltage does not cause the microcontroller to wake from hibernation.	1	<p>In RTC mode, when this bit is set, the battery voltage level is checked every 512 seconds while in hibernation.</p> <p>In calendar mode, the battery voltage is checked on minutes divisible by 8 while in hibernation.</p> <p>If the voltage is below the level specified by VBATSEL field, the microcontroller wakes from hibernation and the LOWBAT interrupt bit in the HIBRIS register is set.</p>				
Value	Description													
0	The battery voltage level is not automatically checked. Low battery voltage does not cause the microcontroller to wake from hibernation.													
1	<p>In RTC mode, when this bit is set, the battery voltage level is checked every 512 seconds while in hibernation.</p> <p>In calendar mode, the battery voltage is checked on minutes divisible by 8 while in hibernation.</p> <p>If the voltage is below the level specified by VBATSEL field, the microcontroller wakes from hibernation and the LOWBAT interrupt bit in the HIBRIS register is set.</p>													

Bit/Field	Name	Type	Reset	Description
8	VDD3ON	RW	0	<p>VDD Powered</p> <p>Value Description</p> <p>0 The internal switches are not used. The \overline{HIB} signal should be used to control an external switch or regulator.</p> <p>1 The internal switches control the power to the on-chip modules (VDD3ON mode).</p> <p>Regardless of the status of the VDD3ON bit, the \overline{HIB} signal is asserted during Hibernate mode. Thus, when VDD3ON is set, the \overline{HIB} signal should not be connected to the 3.3V regulator, and the 3.3V power source should remain connected. When this bit is set while in hibernation, all pins are held in the state they were in prior to entering hibernation. For example, inputs remain inputs; outputs driven high remain driven high, and so on.</p> <p>Ports retain their state in VDD3ON mode until the RETCLR bit is cleared. The RETCLR bit must be set when the VDD3ON bit is set.</p>
7	VABORT	RW	0	<p>Power Cut Abort Enable</p> <p>Value Description</p> <p>0 The microcontroller goes into hibernation regardless of the voltage level of the battery.</p> <p>1 When this bit is set, the battery voltage level is checked before entering hibernation. If V_{BAT} is less than the voltage specified by VBATSEL, the microcontroller does not go into hibernation.</p>
6	CLK32EN	RW	0	<p>Clocking Enable</p> <p>This bit must be enabled to use the Hibernation module.</p> <p>Value Description</p> <p>0 The Hibernation module clock source is disabled.</p> <p>1 The Hibernation module clock source is enabled.</p>
5	reserved	RO	0	<p>Software should not rely on the value of a reserved bit. To provide compatibility with future products, the value of a reserved bit should be preserved across a read-modify-write operation.</p>
4	PINWEN	RW	0	<p>External Wake and Interrupt Pin Enable</p> <p>Value Description</p> <p>0 The status of the \overline{WAKE} or an external I/O wake pad source pin has no effect on hibernation.</p> <p>1 An assertion of the \overline{WAKE} pin or an external I/O wake pad source takes the microcontroller out of hibernation. An external I/O wake pad interrupt may be generated in active mode.</p> <p>Note: The external I/O wake pad interrupt is set if the \overline{WAKE} pin is asserted in Run, Sleep, or Deep Sleep mode regardless of whether the PINWEN bit is 0x0 or 0x1. The interrupt may be forwarded to the processor by setting the EXTW bit in the HIBIM register.</p>

Bit/Field	Name	Type	Reset	Description						
3	RTCWEN	RW	0	<p>RTC Wake-up Enable</p> <table border="1"> <thead> <tr> <th>Value</th> <th>Description</th> </tr> </thead> <tbody> <tr> <td>0</td> <td>An RTC match event has no effect on hibernation.</td> </tr> <tr> <td>1</td> <td>An RTC match event (the value the HIBRTCC register matches the value of the HIBRTCM0 register and the value of the RTCSSC field matches the RTCSSM field in the HIBRTCSS register) takes the microcontroller out of hibernation.</td> </tr> </tbody> </table>	Value	Description	0	An RTC match event has no effect on hibernation.	1	An RTC match event (the value the HIBRTCC register matches the value of the HIBRTCM0 register and the value of the RTCSSC field matches the RTCSSM field in the HIBRTCSS register) takes the microcontroller out of hibernation.
Value	Description									
0	An RTC match event has no effect on hibernation.									
1	An RTC match event (the value the HIBRTCC register matches the value of the HIBRTCM0 register and the value of the RTCSSC field matches the RTCSSM field in the HIBRTCSS register) takes the microcontroller out of hibernation.									
2	reserved	RO	0	Software should not rely on the value of a reserved bit. To provide compatibility with future products, the value of a reserved bit should be preserved across a read-modify-write operation.						
1	HIBREQ	RW	0	<p>Hibernation Request</p> <table border="1"> <thead> <tr> <th>Value</th> <th>Description</th> </tr> </thead> <tbody> <tr> <td>0</td> <td>No hibernation request.</td> </tr> <tr> <td>1</td> <td>Set this bit to initiate hibernation.</td> </tr> </tbody> </table> <p>After a wake-up event, this bit is automatically cleared by hardware. A hibernation request is ignored if both the PINWEN and RTCWEN bits are clear.</p>	Value	Description	0	No hibernation request.	1	Set this bit to initiate hibernation.
Value	Description									
0	No hibernation request.									
1	Set this bit to initiate hibernation.									
0	RTCEN	RW	0	<p>RTC Timer/Calendar Enable</p> <p>This bit must be set to enable RTC or calendar mode. For calendar mode enable, the CALEN bit in the HIBCALCTL register must also be set.</p> <table border="1"> <thead> <tr> <th>Value</th> <th>Description</th> </tr> </thead> <tbody> <tr> <td>0</td> <td>The Hibernation module RTC and calendar mode are disabled.</td> </tr> <tr> <td>1</td> <td>The Hibernation module RTC and calendar mode are enabled.</td> </tr> </tbody> </table> <p>Note: The low-frequency oscillator has a wide frequency variation, therefore the RTC is not accurate when using this clock source.</p>	Value	Description	0	The Hibernation module RTC and calendar mode are disabled.	1	The Hibernation module RTC and calendar mode are enabled.
Value	Description									
0	The Hibernation module RTC and calendar mode are disabled.									
1	The Hibernation module RTC and calendar mode are enabled.									

Register 5: Hibernation Interrupt Mask (HIBIM), offset 0x014

This register is the interrupt mask register for the Hibernation module interrupt sources. Each bit in this register masks the corresponding bit in the **Hibernation Raw Interrupt Status (HIBRIS)** register. If a bit is unmasked, the interrupt is sent to the interrupt controller. If the bit is masked, the interrupt is not sent to the interrupt controller. The **WC** bit of the **HIBIM** register may be set before the **CLK32EN** bit of the **HIBCTL** register is set. This allows software to use the **WC** interrupt trigger to detect when the **RTCOSC** clock is stable, which may be in excess of one second. If the **WC** bit is set before the **CLK32EN** has been set, the mask value is not preserved over a hibernate cycle unless the bit is written a second time.

Note: The **WC** bit of this register is in the system clock domain such that a write to this bit is immediate and may be done before the **CLK32EN** bit is set in the **HIBCTL** register.

Hibernation Interrupt Mask (HIBIM)

Base 0x400F.C000
 Offset 0x014
 Type RW, reset 0x0000.0000

	31	30	29	28	27	26	25	24	23	22	21	20	19	18	17	16
	reserved															
Type	RO	RO	RO	RO	RO	RO	RO	RO	RO	RO	RO	RO	RO	RO	RO	RO
Reset	0	0	0	0	0	0	0	0	0	0	0	0	0	0	0	0
	15	14	13	12	11	10	9	8	7	6	5	4	3	2	1	0
	reserved								VDDFAIL	RSTWK	PADIOWK	WC	EXTW	LOWBAT	reserved	RTCALTO
Type	RO	RO	RO	RO	RO	RO	RO	RO	RW	RW	RW	RW	RW	RW	RO	RW
Reset	0	0	0	0	0	0	0	0	0	0	0	0	0	0	0	0

Bit/Field	Name	Type	Reset	Description
31:8	reserved	RO	0x0000.000	Software should not rely on the value of a reserved bit. To provide compatibility with future products, the value of a reserved bit should be preserved across a read-modify-write operation.
7	VDDFAIL	RW	0	VDD Fail Interrupt Mask Value Description 0 The VDDFAIL interrupt is suppressed and not sent to the interrupt controller. 1 An interrupt is sent to the interrupt controller when the VDDFAIL bit in the HIBRIS register is set.
6	RSTWK	RW	0	Reset Pad I/O Wake-Up Interrupt Mask Value Description 0 The RSTWK interrupt is suppressed and not sent to the interrupt controller. 1 An interrupt is sent to the interrupt controller when the RSTWK bit in the HIBRIS register is set.

Bit/Field	Name	Type	Reset	Description
5	PADIOWK	RW	0	Pad I/O Wake-Up Interrupt Mask Value Description 0 The PADIOWK interrupt is suppressed and not sent to the interrupt controller. 1 An interrupt is sent to the interrupt controller when the PADIOWK bit in the HIBRIS register is set.
4	WC	RW	0	External Write Complete/Capable Interrupt Mask Value Description 0 The WC interrupt is suppressed and not sent to the interrupt controller. 1 An interrupt is sent to the interrupt controller when the WC bit in the HIBRIS register is set.
3	EXTW	RW	0	External Wake-Up Interrupt Mask Value Description 0 The EXTW interrupt is suppressed and not sent to the interrupt controller. 1 An interrupt is sent to the interrupt controller when the EXTW bit in the HIBRIS register is set.
2	LOWBAT	RW	0	Low Battery Voltage Interrupt Mask Value Description 0 The LOWBAT interrupt is suppressed and not sent to the interrupt controller. 1 An interrupt is sent to the interrupt controller when the LOWBAT bit in the HIBRIS register is set.
1	reserved	RO	0	Software should not rely on the value of a reserved bit. To provide compatibility with future products, the value of a reserved bit should be preserved across a read-modify-write operation.
0	RTCALTO	RW	0	RTC Alert 0 Interrupt Mask Value Description 0 The RTCALTO interrupt is suppressed and not sent to the interrupt controller. 1 An interrupt is sent to the interrupt controller when the RTCALTO bit in the HIBRIS register is set.

Register 6: Hibernation Raw Interrupt Status (HIBRIS), offset 0x018

This register is the raw interrupt status for the Hibernation module interrupt sources. Each bit can be masked by clearing the corresponding bit in the **HIBIM** register. When a bit is masked, the interrupt is not sent to the interrupt controller. Bits in this register are cleared by writing a 1 to the corresponding bit in the **Hibernation Interrupt Clear (HIBIC)** register or by entering hibernation.

Hibernation Raw Interrupt Status (HIBRIS)

Base 0x400F.C000
 Offset 0x018
 Type RO, reset 0x0000.0000

	31	30	29	28	27	26	25	24	23	22	21	20	19	18	17	16
	reserved															
Type	RO	RO	RO	RO	RO	RO	RO	RO	RO	RO	RO	RO	RO	RO	RO	RO
Reset	0	0	0	0	0	0	0	0	0	0	0	0	0	0	0	0
	15	14	13	12	11	10	9	8	7	6	5	4	3	2	1	0
	reserved								VDDFAIL	RSTWK	PADIOWK	WC	EXTW	LOWBAT	reserved	RTCALTO
Type	RO	RO	RO	RO	RO	RO	RO	RO	RO	RO	RO	RO	RO	RO	RO	RO
Reset	0	0	0	0	0	0	0	0	0	0	0	0	0	0	0	0

Bit/Field	Name	Type	Reset	Description
31:8	reserved	RO	0x0000.000	Software should not rely on the value of a reserved bit. To provide compatibility with future products, the value of a reserved bit should be preserved across a read-modify-write operation.
7	VDDFAIL	RO	0	VDD Fail Raw Interrupt Status Value Description 0 No VDDFAIL interrupt condition exists. 1 An interrupt is sent to the interrupt controller because of arbitrary power removal or because one or more of the supplies (V_{DD} , V_{DDA} or V_{DDC}) has dropped below the defined operating range.
6	RSTWK	RO	0	Reset Pad I/O Wake-Up Raw Interrupt Status Value Description 0 The $\overline{\text{RESET}}$ pin has not been asserted or has not been enabled to wake the device from hibernation. 1 An interrupt is sent to the interrupt controller because the $\overline{\text{RESET}}$ pin has been programmed to wake the device from hibernation.
5	PADIOWK	RO	0	Pad I/O Wake-Up Raw Interrupt Status Value Description 0 One of the wake-enabled GPIO pins or the external $\overline{\text{RESET}}$ pin has not been asserted or has not been enabled to wake the device from hibernation. 1 An interrupt is sent to the interrupt controller because one of the wake-enabled GPIO pins or the external $\overline{\text{RESET}}$ pin has been asserted.

Bit/Field	Name	Type	Reset	Description
4	WC	RO	0	<p>Write Complete/Capable Raw Interrupt Status</p> <p>Value Description</p> <p>0 The <code>WRC</code> bit in the <code>HIBCTL</code> has not been set.</p> <p>1 The <code>WRC</code> bit in the <code>HIBCTL</code> has been set.</p> <p>This bit is cleared by writing a 1 to the <code>WC</code> bit in the <code>HIBIC</code> register.</p>
3	EXTW	RO	0	<p>External Wake-Up Raw Interrupt Status</p> <p>Note that a wake signal source must be cleared by the application after the interrupt has been registered.</p> <p>Value Description</p> <p>0 The <code>WAKE</code> pin has not been asserted.</p> <p>1 The <code>WAKE</code> pin has been asserted.</p> <p>This bit is cleared by writing a 1 to the <code>EXTW</code> bit in the <code>HIBIC</code> register.</p> <p>Note: The <code>EXTW</code> bit is set if the <code>WAKE</code> pin is asserted in any mode of operation (Run, Sleep, Deep Sleep) regardless of whether the <code>PINWEN</code> bit is set in the <code>HIBCTL</code> register.</p>
2	LOWBAT	RO	0	<p>Low Battery Voltage Raw Interrupt Status</p> <p>Value Description</p> <p>0 The battery voltage has not dropped below V_{LOWBAT}.</p> <p>1 The battery voltage dropped below V_{LOWBAT}.</p> <p>This bit is cleared by writing a 1 to the <code>LOWBAT</code> bit in the <code>HIBIC</code> register.</p>
1	reserved	RO	0	<p>Software should not rely on the value of a reserved bit. To provide compatibility with future products, the value of a reserved bit should be preserved across a read-modify-write operation.</p>
0	RTCALTO	RO	0	<p>RTC Alert 0 Raw Interrupt Status</p> <p>Value Description</p> <p>0 No match</p> <p>1 If the RTC is enabled, the value of the <code>HIBRTCC</code> register matches the value in the <code>HIBRTCM0</code> register and the value of the <code>RTCSSC</code> field matches the <code>RTCSSM</code> field in the <code>HIBRTCSS</code> register.</p> <p>If the Calendar function is enabled, this interrupt status indicates that one or more of the allowed fields in the <code>HIBCALO/1</code> register matches in the <code>HIBCALM0/1</code> register..</p> <p>This bit is cleared by writing a 1 to the <code>RTCALTO</code> bit in the <code>HIBIC</code> register.</p>

Register 7: Hibernation Masked Interrupt Status (HIBMIS), offset 0x01C

This register is the masked interrupt status for the Hibernation module interrupt sources. Bits in this register are the AND of the corresponding bits in the **HIBRIS** and **HIBIM** registers. When both corresponding bits are set, the bit in this register is set, and the interrupt is sent to the interrupt controller.

Hibernation Masked Interrupt Status (HIBMIS)

Base 0x400F.C000
 Offset 0x01C
 Type RO, reset 0x0000.0000

	31	30	29	28	27	26	25	24	23	22	21	20	19	18	17	16
	reserved															
Type	RO	RO	RO	RO	RO	RO	RO	RO	RO	RO	RO	RO	RO	RO	RO	RO
Reset	0	0	0	0	0	0	0	0	0	0	0	0	0	0	0	0
	15	14	13	12	11	10	9	8	7	6	5	4	3	2	1	0
	reserved								VDDFAIL	RSTWK	PADIOWK	WC	EXTW	LOWBAT	reserved	RTCALTO
Type	RO	RO	RO	RO	RO	RO	RO	RO	RO	RO	RO	RO	RO	RO	RO	RO
Reset	0	0	0	0	0	0	0	0	0	0	0	0	0	0	0	0

Bit/Field	Name	Type	Reset	Description
31:8	reserved	RO	0x0000.000	Software should not rely on the value of a reserved bit. To provide compatibility with future products, the value of a reserved bit should be preserved across a read-modify-write operation.
7	VDDFAIL	RO	0	VDD Fail Interrupt Mask Value Description 0 An VDDFAIL interrupt has not occurred or is masked. 1 An unmasked interrupt was signaled due to an arbitrary loss of power or because on or more of the voltage supplies (VDD, VDDA or VDDC) has dropped below the defined operating range.
6	RSTWK	RO	0	Reset Pad I/O Wake-Up Interrupt Mask Value Description 0 An external reset interrupt has not occurred or is masked. 1 An unmasked interrupt was signaled due to a $\overline{\text{RESET}}$ pin assertion.
5	PADIOWK	RO	0	Pad I/O Wake-Up Interrupt Mask Value Description 0 An external GPIO or reset interrupt has not occurred or is masked. 1 An unmasked interrupt was signaled due to a wake-enabled GPIO or $\overline{\text{RESET}}$ pin assertion.

Bit/Field	Name	Type	Reset	Description
4	WC	RO	0	<p>Write Complete/Capable Masked Interrupt Status</p> <p>Value Description</p> <p>0 The <code>WRC</code> bit has not been set or the interrupt is masked.</p> <p>1 An unmasked interrupt was signaled due to the <code>WRC</code> bit being set.</p> <p>This bit is cleared by writing a 1 to the <code>WC</code> bit in the HIBIC register.</p>
3	EXTW	RO	0	<p>External Wake-Up Masked Interrupt Status</p> <p>Value Description</p> <p>0 An external wake-up interrupt has not occurred or is masked.</p> <p>1 An unmasked interrupt was signaled due to a <code>WAKE</code> pin assertion.</p> <p>This bit is cleared by writing a 1 to the <code>EXTW</code> bit in the HIBIC register.</p>
2	LOWBAT	RO	0	<p>Low Battery Voltage Masked Interrupt Status</p> <p>Value Description</p> <p>0 A low-battery voltage interrupt has not occurred or is masked.</p> <p>1 An unmasked interrupt was signaled due to a low-battery voltage condition.</p> <p>This bit is cleared by writing a 1 to the <code>LOWBAT</code> bit in the HIBIC register.</p>
1	reserved	RO	0	<p>Software should not rely on the value of a reserved bit. To provide compatibility with future products, the value of a reserved bit should be preserved across a read-modify-write operation.</p>
0	RTCALTO	RO	0	<p>RTC Alert 0 Masked Interrupt Status</p> <p>Note: The MIS may apply to either the RTC or calendar block depending on which is enabled.</p> <p>Value Description</p> <p>0 An RTC or calendar match interrupt has not occurred or is masked.</p> <p>1 An unmasked interrupt was signaled due to an RTC or calendar match.</p> <p>This bit is cleared by writing a 1 to the <code>RTCALTO</code> bit in the HIBIC register.</p>

Register 8: Hibernation Interrupt Clear (HIBIC), offset 0x020

This register is the interrupt write-one-to-clear register for the Hibernation module interrupt sources. Writing a 1 to a bit clears the corresponding interrupt in the **HIBRIS** register.

Note: Writes to the **RSTWK**, **PADIOWK** and **WC** bits of this register are immediate and the status may be read from the **HIBRIS** and **HIBMIS** registers without monitoring the **WRC** bit of the **HIBCTL** register.

Note: All I/O wake sources are cleared by a write to either or both the **RSTWK** and **PADIOWK** bits. This clears the source of interrupts for **RSTWK**, **PADIOWK** and the **GPIOWAKESTAT** register.

Hibernation Interrupt Clear (HIBIC)

Base 0x400F.C000
 Offset 0x020
 Type RW1C, reset 0x0000.0000

	31	30	29	28	27	26	25	24	23	22	21	20	19	18	17	16
	reserved															
Type	RO	RO	RO	RO	RO	RO	RO	RO	RO	RO	RO	RO	RO	RO	RO	RO
Reset	0	0	0	0	0	0	0	0	0	0	0	0	0	0	0	0
	15	14	13	12	11	10	9	8	7	6	5	4	3	2	1	0
	reserved								VDDFAIL	RSTWK	PADIOWK	WC	EXTW	LOWBAT	reserved	RTCALTO
Type	RO	RO	RO	RO	RO	RO	RO	RO	RW1C	RW1C	RW1C	RW1C	RW1C	RW1C	RO	RW1C
Reset	0	0	0	0	0	0	0	0	0	0	0	0	0	0	0	0

Bit/Field	Name	Type	Reset	Description
31:8	reserved	RO	0x0000.000	Software should not rely on the value of a reserved bit. To provide compatibility with future products, the value of a reserved bit should be preserved across a read-modify-write operation.
7	VDDFAIL	RW1C	0	VDD Fail Interrupt Clear Writing a 1 to this bit clears the VDDFAIL bit in the HIBRIS and HIBMIS registers. Reads return the raw interrupt status.
6	RSTWK	RW1C	0	Reset Pad I/O Wake-Up Interrupt Clear Writing a 1 to this bit clears the RSTWK bit in the HIBRIS and HIBMIS registers. Reads return the raw interrupt status.
5	PADIOWK	RW1C	0	Pad I/O Wake-Up Interrupt Clear Writing a 1 to this bit clears the PADIOWK bit in the HIBRIS and HIBMIS registers. Reads return the raw interrupt status.
4	WC	RW1C	0	Write Complete/Capable Interrupt Clear Writing a 1 to this bit clears the WC bit in the HIBRIS and HIBMIS registers. Reads return the raw interrupt status.
3	EXTW	RW1C	0	External Wake-Up Interrupt Clear Writing a 1 to this bit clears the EXTW bit in the HIBRIS and HIBMIS registers. Reads return the raw interrupt status.

Bit/Field	Name	Type	Reset	Description
2	LOWBAT	RW1C	0	Low Battery Voltage Interrupt Clear Writing a 1 to this bit clears the LOWBAT bit in the HIBRIS and HIBMIS registers. Reads return the raw interrupt status.
1	reserved	RO	0	Software should not rely on the value of a reserved bit. To provide compatibility with future products, the value of a reserved bit should be preserved across a read-modify-write operation.
0	RTCALTO	RW1C	0	RTC Alert0 Masked Interrupt Clear Writing a 1 to this bit clears the RTCALTO bit in the HIBRIS and HIBMIS registers. Reads return the raw interrupt status. Note: The timer interrupt source cannot be cleared if the RTC value and the HIBRTCM0 register / RTCMSS field values are equal. The match interrupt takes priority over the interrupt clear.

Register 9: Hibernation RTC Trim (HIBRTCT), offset 0x024

This register contains the value that is used to trim the RTC clock predivider. It represents the computed underflow value that is used during the trim cycle. It is represented as $0x7FFF \pm N$ clock cycles, where N is the number of clock cycles to add or subtract every 64 seconds in RTC mode or 60 seconds in calendar mode.

Note: Except for the **HIBIO** and a portion of the **HIBIC** register, all other Hibernation module registers are on the Hibernation module clock domain and have special timing requirements. Software should make use of the **WRC** bit in the **HIBCTL** register to ensure that the required timing gap has elapsed. If the **WRC** bit is clear, any attempted write access is ignored. See “Register Access Timing” on page 543. The **HIBIO** register and bits **RSTWK**, **PADIOWK** and **WC** of the **HIBIC** register do not require waiting for write to complete. Because these registers are clocked by the system clock, writes to these registers/bits are immediate.

Writing to registers other than the **HIBCTL** and **HIBIM** before the **CLK32EN** bit in the **HIBCTL** register has been set may produce unexpected results.

Hibernation RTC Trim (HIBRTCT)

Base 0x400F.C000
 Offset 0x024
 Type RW, reset 0x0000.7FFF

	31	30	29	28	27	26	25	24	23	22	21	20	19	18	17	16
	reserved															
Type	RO	RO	RO	RO	RO	RO	RO	RO	RO	RO	RO	RO	RO	RO	RO	RO
Reset	0	0	0	0	0	0	0	0	0	0	0	0	0	0	0	0
	15	14	13	12	11	10	9	8	7	6	5	4	3	2	1	0
	TRIM															
Type	RW	RW	RW	RW	RW	RW	RW	RW	RW	RW	RW	RW	RW	RW	RW	RW
Reset	0	1	1	1	1	1	1	1	1	1	1	1	1	1	1	1

Bit/Field	Name	Type	Reset	Description
31:16	reserved	RO	0x0000	Software should not rely on the value of a reserved bit. To provide compatibility with future products, the value of a reserved bit should be preserved across a read-modify-write operation.
15:0	TRIM	RW	0x7FFF	<p>RTC Trim Value</p> <p>This value is loaded into the RTC predivider every 64 seconds in RTC counter mode.</p> <p>In calendar mode, the value is loaded every 60 seconds.</p> <p>It is used to adjust the RTC rate to account for drift and inaccuracy in the clock source. Compensation can be adjusted by software by moving the default value of 0x7FFF up or down. Moving the value up slows down the RTC and moving the value down speeds up the RTC.</p>

Register 10: Hibernation RTC Sub Seconds (HIBRTCSS), offset 0x028

This register contains the RTC sub seconds counter and match values. The RTC value can be read by first reading the **HIBRTCC** register, reading the **RTCSSC** field in the **HIBRTCSS** register, and then rereading the **HIBRTCC** register. If the two values for **HIBRTCC** are equal, the read is valid.

Note: Except for the **HIBIO** and a portion of the **HIBIC** register, all other Hibernation module registers are on the Hibernation module clock domain and have special timing requirements. Software should make use of the **WRC** bit in the **HIBCTL** register to ensure that the required timing gap has elapsed. If the **WRC** bit is clear, any attempted write access is ignored. See “Register Access Timing” on page 543. The **HIBIO** register and bits **RSTWK**, **PADIOWK** and **WC** of the **HIBIC** register do not require waiting for write to complete. Because these registers are clocked by the system clock, writes to these registers/bits are immediate.

Writing to registers other than the **HIBCTL** and **HIBIM** before the **CLK32EN** bit in the **HIBCTL** register has been set may produce unexpected results.

Note: There is a minimum system clock rate of three times the HIB clock rate to properly read the **HIBRTCSS** register.

Hibernation RTC Sub Seconds (HIBRTCSS)

Base 0x400F.C000

Offset 0x028

Type RW, reset 0x0000.0000

	31	30	29	28	27	26	25	24	23	22	21	20	19	18	17	16
	reserved															
Type	RO	RW	RW	RW	RW	RW	RW	RW	RW	RW	RW	RW	RW	RW	RW	RW
Reset	0	0	0	0	0	0	0	0	0	0	0	0	0	0	0	0
	reserved															
Type	RO	RO	RO	RO	RO	RO	RO	RO	RO	RO	RO	RO	RO	RO	RO	RO
Reset	0	0	0	0	0	0	0	0	0	0	0	0	0	0	0	0

Bit/Field	Name	Type	Reset	Description
31	reserved	RO	0	Software should not rely on the value of a reserved bit. To provide compatibility with future products, the value of a reserved bit should be preserved across a read-modify-write operation.
30:16	RTCSSM	RW	0x0000	RTC Sub Seconds Match The match value is contained in this field in one RTCOSC clock increments. A read returns the current seconds match value.
15	reserved	RO	0	Software should not rely on the value of a reserved bit. To provide compatibility with future products, the value of a reserved bit should be preserved across a read-modify-write operation.
14:0	RTCSSC	RO	0x0000	RTC Sub Seconds Count This field contains the sub second RTC count and is read as RTCOSC clock units. For the 32.768-kHz clock source, this would be in units of 1/32,768 seconds.

Register 11: Hibernation IO Configuration (HIBIO), offset 0x02C

This register is used to lock and unlock the external wake pin levels and enable the external RST pin and/or GPIO pins, Port K[7:4], as valid external WAKE sources.

Note: This register is in the system clock domain and does not require monitoring the WRC bit of the HIBCTL register before issuing a read or write of this register. Writes to this register are immediate.

Note: This register is in the core voltage domain and will not retain values over a hibernate cycle

Hibernation IO Configuration (HIBIO)

Base 0x400F.C000
 Offset 0x02C
 Type RW, reset 0x8000.0000

	31	30	29	28	27	26	25	24	23	22	21	20	19	18	17	16
	IOWRC	reserved														
Type	RO	RO	RO	RO	RO	RO	RO	RO	RO	RO	RO	RO	RO	RO	RO	RO
Reset	1	0	0	0	0	0	0	0	0	0	0	0	0	0	0	0
	15	14	13	12	11	10	9	8	7	6	5	4	3	2	1	0
	reserved											WURSTEN	reserved			WUUNLK
Type	RO	RO	RO	RO	RO	RO	RO	RO	RO	RO	RO	RW	RO	RO	RO	RW
Reset	0	0	0	0	0	0	0	0	0	0	0	0	0	0	0	0

Bit/Field	Name	Type	Reset	Description
31	IOWRC	RO	0x1	<p>I/O Write Complete</p> <p>Indicates whether or not the configuration that was programmed by the WURSTEN bit or GPIOWAKEPEN and GPIOWAKELVL registers have propagated through the pad ring.</p> <p>Value Description</p> <p>0 The changes programmed in the external pad I/O wake source registers have not propagated through the pad I/O.</p> <p>1 The changes programmed in the external pad I/O wake source registers have propagated through the pad I/O.</p>
30:5	reserved	RO	0x0000.000	Software should not rely on the value of a reserved bit. To provide compatibility with future products, the value of a reserved bit should be preserved across a read-modify-write operation.
4	WURSTEN	RW	0	<p>Reset Wake Source Enable</p> <p>This register bit programming takes affect after WUUNLK has been set.</p> <p>Value Description</p> <p>0 The $\overline{\text{RST}}$ signal is not enabled as a wake source.</p> <p>1 The $\overline{\text{RST}}$ signal is enabled as a wake source.</p>
3:1	reserved	RO	0x0	Software should not rely on the value of a reserved bit. To provide compatibility with future products, the value of a reserved bit should be preserved across a read-modify-write operation.

Bit/Field	Name	Type	Reset	Description
0	WUUNLK	RW	0	I/O Wake Pad Configuration Enable
				Value Description
			0	The I/O WAKE configuration set by the <code>WURSTEN</code> bit or in the GPIO module registers <code>GPIOWAKEPEN</code> and <code>GPIOWAKELVL</code> is ignored.
			1	Implement the I/O WAKE configuration, level and enables for the external <code>RST</code> pin and/or GPIO wake-enabled pins.
			Note:	This bit must be cleared before issuing a hibernate request by setting the <code>HIBREQ</code> bit in the <code>HIBCTL</code> register.

Register 12: Hibernation Data (HIBDATA), offset 0x030-0x06F

This address space is implemented as a 16x32-bit memory (64 bytes). It can be loaded by the system processor in order to store state information and retains its state during a power cut operation as long as a battery is present. **HIBDATA** registers 0x050 to 0x064 (upper eight words) may only be accessed using the processor privileged mode (default).

Note: Except for the **HIBIO** and a portion of the **HIBIC** register, all other Hibernation module registers are on the Hibernation module clock domain and have special timing requirements. Software should make use of the **WRC** bit in the **HIBCTL** register to ensure that the required timing gap has elapsed. If the **WRC** bit is clear, any attempted write access is ignored. See “Register Access Timing” on page 543. The **HIBIO** register and bits **RSTWK**, **PADIOWK** and **WC** of the **HIBIC** register do not require waiting for write to complete. Because these registers are clocked by the system clock, writes to these registers/bits are immediate.

Writing to registers other than the **HIBCTL** and **HIBIM** before the **CLK32EN** bit in the **HIBCTL** register has been set may produce unexpected results.

Note: If V_{DD} is arbitrarily removed while a **HIBDATA** register write operation is in progress, the write operation must be retried after V_{DD} is reapplied.

Hibernation Data (HIBDATA)

Base 0x400F.C000
 Offset 0x030-0x06F
 Type RW, reset -

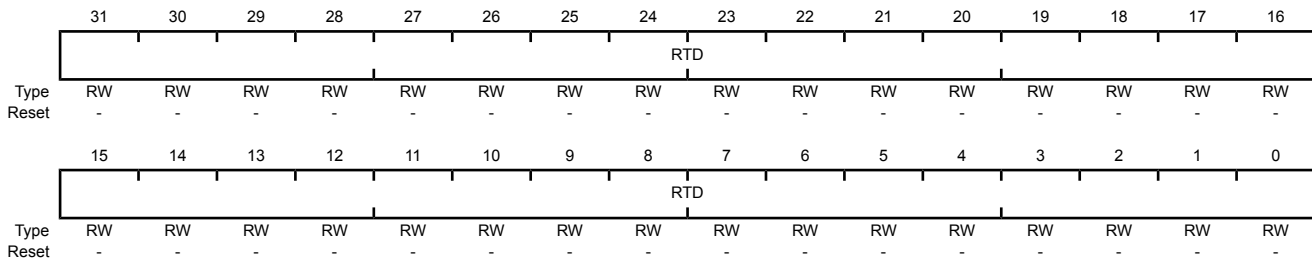

Bit/Field	Name	Type	Reset	Description
31:0	RTD	RW	-	Hibernation Module NV Data

Register 13: Hibernation Calendar Control (HIBCALCTL), offset 0x300

The Hibernate calendar is enabled by setting the `CALEN` bit in the `HIBCALCTL` register. If the `BCD` bit is set, the fields are reported in BCD format.

Hibernation Calendar Control (HIBCALCTL)

Base 0x400F.C000

Offset 0x300

Type RW, reset 0x0000.0000

	31	30	29	28	27	26	25	24	23	22	21	20	19	18	17	16
	reserved															
Type	RO	RO	RO	RO	RO	RO	RO	RO	RO	RO	RO	RO	RO	RO	RO	RO
Reset	0	0	0	0	0	0	0	0	0	0	0	0	0	0	0	0
	15	14	13	12	11	10	9	8	7	6	5	4	3	2	1	0
	reserved													CAL24	reserved	CALEN
Type	RO	RO	RO	RO	RO	RO	RO	RO	RO	RO	RO	RO	RO	RW	RO	RW
Reset	0	0	0	0	0	0	0	0	0	0	0	0	0	0	0	0

Bit/Field	Name	Type	Reset	Description
31:3	reserved	RO	0	Software should not rely on the value of a reserved bit. To provide compatibility with future products, the value of a reserved bit should be preserved across a read-modify-write operation.
2	CAL24	RW	0	Calendar Mode Value Description 0 12 hour, AM/PM Mode 1 24 hour mode
1	reserved	RO	0	Software should not rely on the value of a reserved bit. To provide compatibility with future products, the value of a reserved bit should be preserved across a read-modify-write operation.
0	CALEN	RW	0	RTC Calendar/Counter Mode Select Note that the RTC must be enabled by setting the <code>RTCEN</code> bit in the <code>HIBCTL</code> register to use this mode select. Value Description 0 RTC Counter mode enabled. 1 Calendar mode enabled

Register 14: Hibernation Calendar 0 (HIBCAL0), offset 0x310

The **Hibernation Calendar 0 (HIBCAL0)** register is used when the **CALEN** bit is set in the **HIBCALCTL** register.

Hibernation Calendar 0 (HIBCAL0)

Base 0x400F.C000

Offset 0x310

Type RO, reset 0x0000.0000

	31	30	29	28	27	26	25	24	23	22	21	20	19	18	17	16
	VALID	reserved								AMPM	reserved	HR				
Type	RO	RO	RO	RO	RO	RO	RO	RO	RO	RO	RO	RO	RO	RO	RO	RO
Reset	0	0	0	0	0	0	0	0	0	0	0	0	0	0	0	0
	15	14	13	12	11	10	9	8	7	6	5	4	3	2	1	0
	reserved		MIN					reserved			SEC					
Type	RO	RO	RO	RO	RO	RO	RO	RO	RO	RO	RO	RO	RO	RO	RO	RO
Reset	0	0	0	0	0	0	0	0	0	0	0	0	0	0	0	0

Bit/Field	Name	Type	Reset	Description				
31	VALID	RO	0	<p>Valid Calendar Load</p> <p>The calendar may take several cycles to update as the values roll over. This bit indicates whether the HIBCAL0 register contents are valid.</p> <p>Value Description</p> <table border="0"> <tr> <td>0</td> <td>Register currently updating or initializing</td> </tr> <tr> <td>1</td> <td>HIBCAL0 register valid and ready.</td> </tr> </table>	0	Register currently updating or initializing	1	HIBCAL0 register valid and ready.
0	Register currently updating or initializing							
1	HIBCAL0 register valid and ready.							
30:23	reserved	RO	0	Software should not rely on the value of a reserved bit. To provide compatibility with future products, the value of a reserved bit should be preserved across a read-modify-write operation.				
22	AMPM	RO	0	<p>AM/PM Designation</p> <p>This bit is used when CAL24=0 in the HIBCALCTL register.</p> <p>Value Description</p> <table border="0"> <tr> <td>0</td> <td>AM</td> </tr> <tr> <td>1</td> <td>PM</td> </tr> </table>	0	AM	1	PM
0	AM							
1	PM							
21	reserved	RO	0	Software should not rely on the value of a reserved bit. To provide compatibility with future products, the value of a reserved bit should be preserved across a read-modify-write operation.				
20:16	HR	RO	0	<p>Hours</p> <p>This field holds the hour information in hexadecimal.</p> <p>For military time, bits 20:16 range from 0x0 to 0x17 (0 to 23 hours).</p> <p>For standard time (AM/PM mode) bits 20:16 range from 0x0 to 0x11, with 0x0 representing 12AM or 12 PM.</p>				
15:14	reserved	RO	0	Software should not rely on the value of a reserved bit. To provide compatibility with future products, the value of a reserved bit should be preserved across a read-modify-write operation.				

Bit/Field	Name	Type	Reset	Description
13:8	MIN	RO	0	Minutes This field holds the minute information in hexadecimal. Bits 13:8 correspond to hex values from 0x0 to 0x3b (0 to 59 minutes).
7:6	reserved	RO	0	Software should not rely on the value of a reserved bit. To provide compatibility with future products, the value of a reserved bit should be preserved across a read-modify-write operation.
5:0	SEC	RO	0	Seconds This field holds the seconds value in hexadecimal. Bits 5:0 correspond to hex values from 0x0 to 0x3b (0 to 59 seconds).

Register 15: Hibernation Calendar 1 (HIBCAL1), offset 0x314

The **Hibernation Calendar 1 (HIBCAL1)** register is used when the `CALEN` bit is set in the **HIBCALCTL** register.

Hibernation Calendar 1 (HIBCAL1)

Base 0x400F.C000

Offset 0x314

Type RO, reset 0x0000.0000

	31	30	29	28	27	26	25	24	23	22	21	20	19	18	17	16
	VALID	reserved				DOW			reserved	YEAR						
Type	RO	RO	RO	RO	RO	RO	RO	RO	RO	RO	RO	RO	RO	RO	RO	RO
Reset	0	0	0	0	0	0	0	0	0	0	0	0	0	0	0	0
	15	14	13	12	11	10	9	8	7	6	5	4	3	2	1	0
	reserved				MON			reserved			DOM					
Type	RO	RO	RO	RO	RO	RO	RO	RO	RO	RO	RO	RO	RO	RO	RO	RO
Reset	0	0	0	0	0	0	0	0	0	0	0	0	0	0	0	0

Bit/Field	Name	Type	Reset	Description
31	VALID	RO	0	<p>Valid Calendar Load</p> <p>The calendar may take several cycles to update as the values roll over. This bit indicates whether the HIBCAL1 register contents are valid.</p> <p>Value Description</p> <p>0 Register currently updating or initializing</p> <p>1 HIBCAL1 register valid and ready.</p>
30:27	reserved	RO	0	Software should not rely on the value of a reserved bit. To provide compatibility with future products, the value of a reserved bit should be preserved across a read-modify-write operation.
26:24	DOW	RO	0	<p>Day of Week</p> <p>This field displays the day of the week in the encodings 0x0 to 0x6. The application defines which days are assigned to each encoding.</p>
23	reserved	RO	0	Software should not rely on the value of a reserved bit. To provide compatibility with future products, the value of a reserved bit should be preserved across a read-modify-write operation.
22:16	YEAR	RO	0	<p>Year Value</p> <p>The last two digits of the year are stored in hexadecimal in this field. Bits 22:16 correspond to hex values from 0x0 to 0x63 (0 to 99 years).</p>
15:12	reserved	RO	0	Software should not rely on the value of a reserved bit. To provide compatibility with future products, the value of a reserved bit should be preserved across a read-modify-write operation.
11:8	MON	RO	0	<p>Month</p> <p>This field holds the month value in hexadecimal. Bits 11:8 correspond to hex values from 0x1 to 0xC (1 to 12 months).</p>
7:5	reserved	RO	0	Software should not rely on the value of a reserved bit. To provide compatibility with future products, the value of a reserved bit should be preserved across a read-modify-write operation.

Bit/Field	Name	Type	Reset	Description
4:0	DOM	RO	0	Day of Month This field holds the day of the month value in hexadecimal. Bits 4:0 correspond to hex values from 0x1 to 1F (1 to 31 days). The value 0 is used to show an ignore match.

Register 16: Hibernation Calendar Load 0 (HIBCALLD0), offset 0x320

The **Hibernation Calendar Load (HIBCALLD0)** register is used when the **CALEN** bit is set in the **HIBCALCTL** register.

Note: This register is write-only; any reads to this register read back as zeros. Errant writes to the **HIBCALLD0/1** registers are protected by the Hibernate **HIBLOCK** register.

Hibernation Calendar Load 0 (HIBCALLD0)

Base 0x400F.C000
 Offset 0x320
 Type WO, reset 0x0000.0000

	31	30	29	28	27	26	25	24	23	22	21	20	19	18	17	16
	reserved									AMPM	reserved	HR				
Type	RO	RO	RO	RO	RO	RO	RO	RO	RO	WO	RO	WO	WO	WO	WO	WO
Reset	0	0	0	0	0	0	0	0	0	0	0	0	0	0	0	0
	15	14	13	12	11	10	9	8	7	6	5	4	3	2	1	0
	reserved		MIN						reserved			SEC				
Type	RO	RO	WO	WO	WO	WO	WO	WO	RO	RO	WO	WO	WO	WO	WO	WO
Reset	0	0	0	0	0	0	0	0	0	0	0	0	0	0	0	0

Bit/Field	Name	Type	Reset	Description
31:23	reserved	RO	0	Software should not rely on the value of a reserved bit. To provide compatibility with future products, the value of a reserved bit should be preserved across a read-modify-write operation.
22	AMPM	WO	0	AM/PM Designation This bit is used when CAL24=0 in the HIBCALCTL register. Value Description 0 AM 1 PM
21	reserved	RO	0	Software should not rely on the value of a reserved bit. To provide compatibility with future products, the value of a reserved bit should be preserved across a read-modify-write operation.
20:16	HR	WO	0	Hours This field holds the hour information in hexadecimal. Bits 20:16 correspond to hex values from 0x0 to 0x17 (0 to 23 hours).
15:14	reserved	RO	0	Software should not rely on the value of a reserved bit. To provide compatibility with future products, the value of a reserved bit should be preserved across a read-modify-write operation.
13:8	MIN	WO	0	Minutes This field holds the minute information in hexadecimal. Bits 13:8 correspond to hex values from 0x0 to 0x3B (0 to 59 minutes).
7:6	reserved	RO	0	Software should not rely on the value of a reserved bit. To provide compatibility with future products, the value of a reserved bit should be preserved across a read-modify-write operation.

Bit/Field	Name	Type	Reset	Description
5:0	SEC	WO	0	Seconds This field holds the seconds value in hexadecimal. Bits 5:0 correspond to hex values from 0x0 to 0x3B (0 to 59 seconds).

Register 17: Hibernation Calendar Load (HIBCALLD1), offset 0x324

The **Hibernation Calendar Load 1 (HIBCALLD1)** register is used when the `CALEN` bit is set in the **HIBCALCTL** register.

Note: This register is write-only; any reads to this register read back as zeros. Errant writes to the **HIBCALLD0/1** registers are protected by the Hibernate **HIBLOCK** register.

Hibernation Calendar Load (HIBCALLD1)

Base 0x400F.C000
 Offset 0x324
 Type WO, reset 0x0000.0000

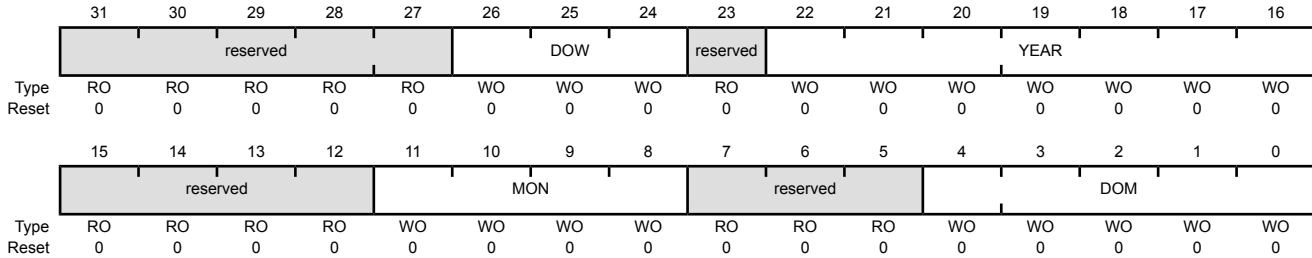

Bit/Field	Name	Type	Reset	Description
31:27	reserved	RO	0	Software should not rely on the value of a reserved bit. To provide compatibility with future products, the value of a reserved bit should be preserved across a read-modify-write operation.
26:24	DOW	WO	0	Day of Week This field is written with the day of the week in the encodings 0x0 to 0x6. The application defines which days are assigned to each encoding.
23	reserved	RO	0	Software should not rely on the value of a reserved bit. To provide compatibility with future products, the value of a reserved bit should be preserved across a read-modify-write operation.
22:16	YEAR	WO	0	Year Value The last two digits of the year are written in this field in hexadecimal. For example, "12" would be programmed into this field for 2012. Bits 22:16 correspond to hex values from 0x0 to 0x63 (0 to 99 years).
15:12	reserved	RO	0	Software should not rely on the value of a reserved bit. To provide compatibility with future products, the value of a reserved bit should be preserved across a read-modify-write operation.
11:8	MON	WO	0	Month The month value is written in this field in hexadecimal. Bits 11:8 correspond to hex values from 0x1 to 0xC (1 to 12 months).
7:5	reserved	RO	0	Software should not rely on the value of a reserved bit. To provide compatibility with future products, the value of a reserved bit should be preserved across a read-modify-write operation.
4:0	DOM	WO	0	Day of Month The day of the month value is written in this field in hexadecimal. Bits 4:0 correspond to hex values from 0x1 to 1F (1 to 31 days). The encoding 0x0 is reserved for the ignore match function.

Register 18: Hibernation Calendar Match 0 (HIBCALM0), offset 0x330

The **Hibernation Calendar Match 0 (HIBCALM0)** register is used when the `CALEN` bit is set in the **HIBCALCTL** register. This register is loaded with desired match values for calendar mode. Once the **HIBCAL0/1** register values equal the **HIBCALM0/1** register values, the `RTCALT0` bit is set in the **HIBRIS** register.

Note: The day of week, month and year are not included in the match functionality.

Hibernation Calendar Match 0 (HIBCALM0)

Base 0x400F.C000
Offset 0x330
Type RW, reset 0x0000.0000

	31	30	29	28	27	26	25	24	23	22	21	20	19	18	17	16
	reserved									AMPM	reserved	HR				
Type	RO	RO	RO	RO	RO	RO	RO	RO	RO	RW	RO	RW	RW	RW	RW	RW
Reset	0	0	0	0	0	0	0	0	0	0	0	0	0	0	0	0
	15	14	13	12	11	10	9	8	7	6	5	4	3	2	1	0
	reserved		MIN					reserved			SEC					
Type	RO	RO	RW	RW	RW	RW	RW	RW	RO	RO	RW	RW	RW	RW	RW	RW
Reset	0	0	0	0	0	0	0	0	0	0	0	0	0	0	0	0

Bit/Field	Name	Type	Reset	Description
31:23	reserved	RO	0	Software should not rely on the value of a reserved bit. To provide compatibility with future products, the value of a reserved bit should be preserved across a read-modify-write operation.
22	AMPM	RW	0	AM/PM Designation This bit is used when <code>CAL24=0</code> in the HIBCALCTL register. Value Description 0 AM 1 PM
21	reserved	RO	0	Software should not rely on the value of a reserved bit. To provide compatibility with future products, the value of a reserved bit should be preserved across a read-modify-write operation.
20:16	HR	RW	0	Hours This field match value for the hours in hexadecimal units. Bits 20:16 correspond to hex values from 0x0 to 0x17 (0 to 23 hours). To ignore the hours match, write this field to all 1s.
15:14	reserved	RO	0	Software should not rely on the value of a reserved bit. To provide compatibility with future products, the value of a reserved bit should be preserved across a read-modify-write operation.
13:8	MIN	RW	0	Minutes This field holds the match value for minutes in hexadecimal units. Bits 13:8 correspond to hex values from 0x0 to 0x3B (0 to 59 minutes). To ignore the hours match, write this field to all 1s.
7:6	reserved	RO	0	Software should not rely on the value of a reserved bit. To provide compatibility with future products, the value of a reserved bit should be preserved across a read-modify-write operation.

Bit/Field	Name	Type	Reset	Description
5:0	SEC	RW	0	Seconds This field holds the match value for seconds. The value is represented in hexadecimal. Bits 5:0 correspond to hex values from 0x0 to 0x3b (0 to 59 seconds). To ignore the hours match, write this field to all 1s.

Register 19: Hibernation Calendar Match 1 (HIBCALM1), offset 0x334

The **Hibernation Calendar Match 1 (HIBCALM1)** register is used when the `CALEN` bit is set in the **HIBCALCTL** register. This register is loaded with desired match values for calendar mode. Once the **HIBCAL0/1** register values equal the **HIBCALM0/1** register values, the `RTCALT0` bit is set in the **HIBRIS** register.

Note: The day of week, month and year are not included in the match functionality.

Hibernation Calendar Match 1 (HIBCALM1)

Base 0x400F.C000

Offset 0x334

Type RW, reset 0x0000.0000

	31	30	29	28	27	26	25	24	23	22	21	20	19	18	17	16
	reserved															
Type	RO	RO	RO	RO	RO	RO	RO	RO	RO	RO	RO	RO	RO	RO	RO	RO
Reset	0	0	0	0	0	0	0	0	0	0	0	0	0	0	0	0
	15	14	13	12	11	10	9	8	7	6	5	4	3	2	1	0
	reserved												DOM			
Type	RO	RO	RO	RO	RO	RO	RO	RO	RO	RO	RO	RO	RW	RW	RW	RW
Reset	0	0	0	0	0	0	0	0	0	0	0	0	0	0	0	0

Bit/Field	Name	Type	Reset	Description
31:5	reserved	RO	0	Software should not rely on the value of a reserved bit. To provide compatibility with future products, the value of a reserved bit should be preserved across a read-modify-write operation.
4:0	DOM	RW	0	Day of Month This field holds the match value for the day of the month in hexadecimal. Bits 4:0 correspond to hex values from 0x1 to 1F (1 to 31 days). To disable match for the day of the month, the value 0x0 is used.

Register 20: Hibernation Lock (HIBLOCK), offset 0x360

Writing 0xA335.9554 to the **HIBLOCK** register enables write access to the **HIBRTCLD**, **HIBCALLD0**, **HIBCALLD1** and Tamper registers. Writing any other value to the **HIBLOCK** register re-enables the locked state for register writes to all the other registers. Reading the **HIBLOCK** register returns the lock status rather than the 32-bit value written. Therefore, when write accesses are disabled, reading the **HIBLOCK** register returns 0x0000.0001 when locked; otherwise, the returned value is 0x0000.0000 (unlocked).

Hibernation Lock (HIBLOCK)

Base 0x400F.C000
 Offset 0x360
 Type RW, reset 0x0000.0000

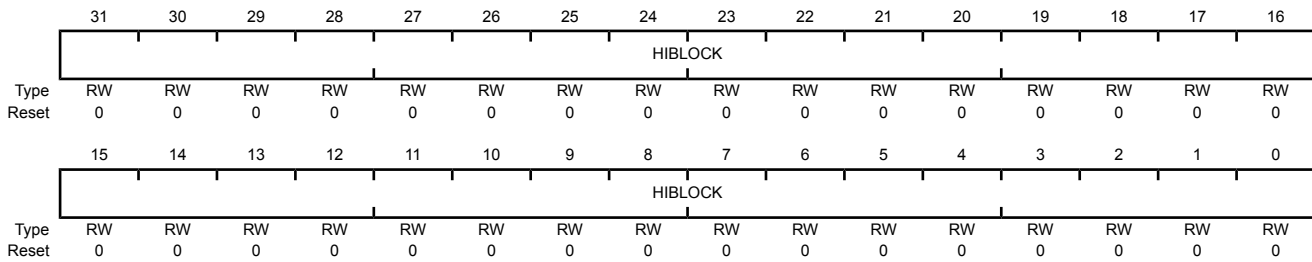

Bit/Field	Name	Type	Reset	Description
31:0	HIBLOCK	RW	0x0000	Hibernate Lock A write of 0xA335.9554 unlocks the HIBRCTL and Tamper registers.

Register 21: HIB Tamper Control (HIBTPCTL), offset 0x400

The **Tamper Control (HIBTPCTL)** register provides control of the module.

Note: Except for the **HIBIO** and a portion of the **HIBIC** register, all other Hibernation module registers are on the Hibernation module clock domain and have special timing requirements. Software should make use of the **WRC** bit in the **HIBCTL** register to ensure that the required timing gap has elapsed. If the **WRC** bit is clear, any attempted write access is ignored. See “Register Access Timing” on page 543. The **HIBIO** register and bits **RSTWK**, **PADIOWK** and **WC** of the **HIBIC** register do not require waiting for write to complete. Because these registers are clocked by the system clock, writes to these registers/bits are immediate.

Writing to registers other than the **HIBCTL** and **HIBIM** before the **CLK32EN** bit in the **HIBCTL** register has been set may produce unexpected results.

Note: Errant writes to the Tamper registers are protected by the Hibernate **HIBLOCK** register.

HIB Tamper Control (HIBTPCTL)

Base 0x400F.C000
Offset 0x400
Type RW, reset 0x0000.0000

	31	30	29	28	27	26	25	24	23	22	21	20	19	18	17	16
	reserved															
Type	RO	RO	RO	RO	RO	RO	RO	RO	RO	RO	RO	RO	RO	RO	RO	RO
Reset	0	0	0	0	0	0	0	0	0	0	0	0	0	0	0	0
	15	14	13	12	11	10	9	8	7	6	5	4	3	2	1	0
	reserved				WAKE	reserved	MEMCLR	reserved				TPCLR	reserved			TPEN
Type	RO	RO	RO	RO	RW	RO	RW	RW	RO	RO	RO	W1C	RO	RO	RO	RW
Reset	0	0	0	0	0	0	0	0	0	0	0	0	0	0	0	0

Bit/Field	Name	Type	Reset	Description
31:12	reserved	RO	0	Software should not rely on the value of a reserved bit. To provide compatibility with future products, the value of a reserved bit should be preserved across a read-modify-write operation.
11	WAKE	RW	0	Wake from Hibernate on a Tamper Event
				Value Description
				0 Do not wake from hibernate on a tamper event.
				1 Wake from hibernate on a tamper event.
10	reserved	RO	0	Software should not rely on the value of a reserved bit. To provide compatibility with future products, the value of a reserved bit should be preserved across a read-modify-write operation.
9:8	MEMCLR	RW	0	HIB Memory Clear on Tamper Event
				Value Description
				0x0 Do not Clear HIB memory on tamper event.
				0x1 Clear Lower 32 Bytes of HIB memory on tamper event
				0x2 Clear upper 32 Bytes of HIB memory on tamper event
				0x3 Clear all HIB memory on tamper event

Bit/Field	Name	Type	Reset	Description
7:5	reserved	RO	0	Software should not rely on the value of a reserved bit. To provide compatibility with future products, the value of a reserved bit should be preserved across a read-modify-write operation.
4	TPCLR	W1C	0	Tamper Event Clear Writing a 1 to this bit clears the tamper event. The status of the clear is reflected in the <i>STATE</i> bit field.
3:1	reserved	RO	0	Software should not rely on the value of a reserved bit. To provide compatibility with future products, the value of a reserved bit should be preserved across a read-modify-write operation.
0	TPEN	RW	0	Tamper Module Enable This bit enables the Tamper module.

Value Description

- 0 Tamper module disabled.
- 1 Tamper module Enabled.

Note: Once tamper is enabled, the following **HIBCTL** register bits are locked and cannot be modified:

- OSCSEL
- OSCDRV
- OSCBYP
- VDD3ON
- CLK32EN
- RTCEN

Register 22: HIB Tamper Status (HIBTPSTAT), offset 0x404

The **HIB Tamper Status (HIBTPCTL)** register provides status of the module.

Note: Except for the **HIBIO** and a portion of the **HIBIC** register, all other Hibernation module registers are on the Hibernation module clock domain and have special timing requirements. Software should make use of the **WRC** bit in the **HIBCTL** register to ensure that the required timing gap has elapsed. If the **WRC** bit is clear, any attempted write access is ignored. See “Register Access Timing” on page 543. The **HIBIO** register and bits **RSTWK**, **PADIOWK** and **WC** of the **HIBIC** register do not require waiting for write to complete. Because these registers are clocked by the system clock, writes to these registers/bits are immediate.

Writing to registers other than the **HIBCTL** and **HIBIM** before the **CLK32EN** bit in the **HIBCTL** register has been set may produce unexpected results.

Note: Errant writes to the Tamper registers are protected by the Hibernate **HIBLOCK** register.

HIB Tamper Status (HIBTPSTAT)

Base 0x400F.C000

Offset 0x404

Type RW1C, reset 0x0000.0000

	31	30	29	28	27	26	25	24	23	22	21	20	19	18	17	16	
	reserved																
Type	RO	RO	RO	RO	RO	RO	RO	RO	RO	RO	RO	RO	RO	RO	RO	RO	
Reset	0	0	0	0	0	0	0	0	0	0	0	0	0	0	0	0	
	15	14	13	12	11	10	9	8	7	6	5	4	3	2	1	0	
	reserved													STATE		XOSCST	XOSCFAIL
Type	RO	RO	RO	RO	RO	RO	RO	RO	RO	RO	RO	RO	RO	RO	RO	RO	RW1C
Reset	0	0	0	0	0	0	0	0	0	0	0	0	0	0	0	0	0

Bit/Field	Name	Type	Reset	Description
31:4	reserved	RO	0	Software should not rely on the value of a reserved bit. To provide compatibility with future products, the value of a reserved bit should be preserved across a read-modify-write operation.
3:2	STATE	RO	0	<p>Tamper Module Status</p> <p>Tamper is defined as being configured when the tamper I/Os have been enabled (setting the ENx bits in the HIBTPIO register).</p> <p>Value Description</p> <p>0x0 Tamper disabled.</p> <p>0x1 Tamper configured.</p> <p>0x2 Tamper pin event occurred.</p>
1	XOSCST	RO	0	<p>External Oscillator Status</p> <p>Value Description</p> <p>0 Active</p> <p>1 Stopped</p>

Bit/Field	Name	Type	Reset	Description
0	XOSCFAIL	RW1C	0	External Oscillator Failure Write a 1 to this bit to clear it.
				Value Description
				0 External oscillator is valid.
				1 External oscillator has failed

Register 23: HIB Tamper I/O Control (HIBTPIO), offset 0x410

The **HIB Tamper I/O Control (HIBTPIO)** register provides control of the Tamper I/O.

Note: Except for the **HIBIO** and a portion of the **HIBIC** register, all other Hibernation module registers are on the Hibernation module clock domain and have special timing requirements. Software should make use of the **WRC** bit in the **HIBCTL** register to ensure that the required timing gap has elapsed. If the **WRC** bit is clear, any attempted write access is ignored. See “Register Access Timing” on page 543. The **HIBIO** register and bits **RSTWK**, **PADIOWK** and **WC** of the **HIBIC** register do not require waiting for write to complete. Because these registers are clocked by the system clock, writes to these registers/bits are immediate.

Writing to registers other than the **HIBCTL** and **HIBIM** before the **CLK32EN** bit in the **HIBCTL** register has been set may produce unexpected results.

Note: Errant writes to the Tamper registers are protected by the Hibernate **HIBLOCK** register.

HIB Tamper I/O Control (HIBTPIO)

Base 0x400F.C000

Offset 0x410

Type RW, reset 0x0000.0000

	31	30	29	28	27	26	25	24	23	22	21	20	19	18	17	16
	reserved				GFLTR3	PUEN3	LEV3	EN3	reserved				GFLTR2	PUEN2	LEV2	EN2
Type	RO	RO	RO	RO	RW	RW	RW	RW	RO	RO	RO	RO	RW	RW	RW	RW
Reset	0	0	0	0	0	0	0	0	0	0	0	0	0	0	0	0
	15	14	13	12	11	10	9	8	7	6	5	4	3	2	1	0
	reserved				GFLTR1	PUEN1	LEV1	EN1	reserved				GFLTR0	PUEN0	LEV0	EN0
Type	RO	RO	RO	RO	RW	RW	RW	RW	RO	RO	RO	RO	RW	RW	RW	RW
Reset	0	0	0	0	0	0	0	0	0	0	0	0	0	0	0	0

Bit/Field	Name	Type	Reset	Description
31:28	reserved	RO	0	Software should not rely on the value of a reserved bit. To provide compatibility with future products, the value of a reserved bit should be preserved across a read-modify-write operation.
27	GFLTR3	RW	0	TMPR3 Glitch Filtering Value Description 0 A trigger match level is ignored until the TMPR3 signal is stable for two hibernate clocks. 1 A trigger match level is ignored until the TMPR3 signal is stable for 3,071 Hibernate Clocks (93.7ms using 32.768 kHz).
26	PUEN3	RW	0	TMPR3 Internal Weak Pull-up Enable Value Description 0 Pull-up disabled 1 Pull-up enabled

Bit/Field	Name	Type	Reset	Description
25	LEV3	RW	0	<p>TMPR3 Trigger Level</p> <p>Value Description</p> <p>0 Trigger on level low</p> <p>1 Trigger on level high</p>
24	EN3	RW	0	<p>TMPR3 Enable</p> <p>Value Description</p> <p>0 Detect disabled</p> <p>1 Detect enabled</p>
23:20	reserved	RO	0	Software should not rely on the value of a reserved bit. To provide compatibility with future products, the value of a reserved bit should be preserved across a read-modify-write operation.
19	GFLTR2	RW	0	<p>TMPR2 Glitch Filtering</p> <p>Value Description</p> <p>0 A trigger match level is ignored until the <code>TMPR2</code> signal is stable for two hibernate clocks.</p> <p>1 A trigger match level is ignored until the <code>TMPR2</code> signal is stable for 3,071 Hibernate Clocks (93.7ms using 32.768 kHz).</p>
18	PUEN2	RW	0	<p>TMPR2 Internal Weak Pull-up Enable</p> <p>Value Description</p> <p>0 Pull-up disabled</p> <p>1 Pull-up enabled</p>
17	LEV2	RW	0	<p>TMPR2 Trigger Level</p> <p>Value Description</p> <p>0 Trigger on level low</p> <p>1 Trigger on level high</p>
16	EN2	RW	0	<p>TMPR2 Enable</p> <p>Value Description</p> <p>0 Detect disabled</p> <p>1 Detect enabled</p>
15:12	reserved	RO	0	Software should not rely on the value of a reserved bit. To provide compatibility with future products, the value of a reserved bit should be preserved across a read-modify-write operation.

Bit/Field	Name	Type	Reset	Description
11	GFLTR1	RW	0	<p>TMPR1 Glitch Filtering</p> <p>Value Description</p> <p>0 A trigger match level is ignored until the <code>TMPR1</code> signal is stable for two hibernate clocks.</p> <p>1 A trigger match level is ignored until the <code>TMPR1</code> signal is stable for 3,071 Hibernate Clocks (93.7ms using 32.768 kHz).</p>
10	PUEN1	RW	0	<p>TMPR1 Internal Weak Pull-up Enable</p> <p>Value Description</p> <p>0 Pull-up disabled</p> <p>1 Pull-up enabled</p>
9	LEV1	RW	0	<p>TMPR1 Trigger Level</p> <p>Value Description</p> <p>0 Trigger on level low</p> <p>1 Trigger on level high</p>
8	EN1	RW	0	<p>TMPR1Enable</p> <p>Value Description</p> <p>0 Detect disabled</p> <p>1 Detect enabled</p>
7:4	reserved	RO	0	Software should not rely on the value of a reserved bit. To provide compatibility with future products, the value of a reserved bit should be preserved across a read-modify-write operation.
3	GFLTR0	RW	0	<p>TMPR0 Glitch Filtering</p> <p>Value Description</p> <p>0 A trigger match level is ignored until the <code>TMPR0</code> signal is stable for two hibernate clocks.</p> <p>1 A trigger match level is ignored until the <code>TMPR0</code> signal is stable for 3,071 Hibernate Clocks (93.7ms using 32.768 kHz).</p>
2	PUEN0	RW	0	<p>TMPR0 Internal Weak Pull-up Enable</p> <p>Value Description</p> <p>0 Pull-up disabled</p> <p>1 Pull-up enabled</p>

Bit/Field	Name	Type	Reset	Description
1	LEV0	RW	0	TMPR0 Trigger Level Value Description 0 Trigger on level low 1 Trigger on level high
0	EN0	RW	0	TMPR0 Enable Value Description 0 Detect disabled 1 Detect enabled

Register 24: HIB Tamper Log 0 (HIBTPLOG0), offset 0x4E0

Register 25: HIB Tamper Log 2 (HIBTPLOG2), offset 0x4E8

Register 26: HIB Tamper Log 4 (HIBTPLOG4), offset 0x4F0

Register 27: HIB Tamper Log 6 (HIBTPLOG6), offset 0x4F8

The **HIB Tamper Log (HIBTPLOG)** even registers capture the time information during a tamper event. Up to four tamper logs can be stored. The **HIBTPLOG** registers are cleared when the **TPCLR** bit is written in the **HIBTPCTL** register.

Note: It is recommended that an external oscillator is used if accurate time stamps on the tamper log are critical.

HIB Tamper Log 0 (HIBTPLOG0)

Base 0x400F.C000

Offset 0x4E0

Type RO, reset 0x0000.0000

	31	30	29	28	27	26	25	24	23	22	21	20	19	18	17	16
	TIME															
Type	RO	RO	RO	RO	RO	RO	RO	RO	RO	RO	RO	RO	RO	RO	RO	RO
Reset	0	0	0	0	0	0	0	0	0	0	0	0	0	0	0	0
	15	14	13	12	11	10	9	8	7	6	5	4	3	2	1	0
	TIME															
Type	RO	RO	RO	RO	RO	RO	RO	RO	RO	RO	RO	RO	RO	RO	RO	RO
Reset	0	0	0	0	0	0	0	0	0	0	0	0	0	0	0	0

Bit/Field	Name	Type	Reset	Description
31:0	TIME	RO	0x0	<p>Tamper Log Calendar Information.</p> <p>When the hibernate module is configured for RTC count mode, the time from the RTCC register is captured on a tamper event.</p> <p>If the calendar function is enabled, the captured time is configured as the hex values for year, month, day, hour, minute and seconds. 24 hour mode should be used by setting the CAL24 bit in HIBCALCTL register. The format of the calendar information is as follows:</p> <ul style="list-style-type: none"> ■ TIME[31:26]: Year (0-64) ■ TIME[25:22]: Month ■ TIME[21:17]: Day of month ■ TIME[16:12]: Hours ■ TIME[11:6]: Minutes ■ TIME[5:0]: Seconds

Register 28: HIB Tamper Log 1 (HIBTPLOG1), offset 0x4E4

Register 29: HIB Tamper Log 3 (HIBTPLOG3), offset 0x4EC

Register 30: HIB Tamper Log 5 (HIBTPLOG5), offset 0x4F4

Register 31: HIB Tamper Log 7 (HIBTPLOG7), offset 0x4FC

The **HIB Tamper Log (HIBTPLOGn)** odd registers capture the trigger information during a tamper event. Up to four tamper logs can be stored. The **HIBTPLOG** registers are cleared when the **TPCLR** bit is set to 1 in the **HIBTPCTL** register. The **HIBTPLOG7** register contains to OR of all events after the 3rd event is logged in **HIBTPLOG5**. The **HIBTPLOG7** register is cleared on a Hibernation module reset.

HIB Tamper Log 1 (HIBTPLOG1)

Base 0x400F.C000

Offset 0x4E4

Type RO, reset 0x0000.0000

	31	30	29	28	27	26	25	24	23	22	21	20	19	18	17	16
	reserved															XOSC
Type	RO	RO	RO	RO	RO	RO	RO	RO	RO	RO	RO	RO	RO	RO	RO	RO
Reset	0	0	0	0	0	0	0	0	0	0	0	0	0	0	0	0
	15	14	13	12	11	10	9	8	7	6	5	4	3	2	1	0
	reserved												TRIG3	TRIG2	TRIG1	TRIG0
Type	RO	RO	RO	RO	RO	RO	RO	RO	RO	RO	RO	RO	RO	RO	RO	RO
Reset	0	0	0	0	0	0	0	0	0	0	0	0	0	0	0	0

Bit/Field	Name	Type	Reset	Description
31:17	reserved	RO	0	Software should not rely on the value of a reserved bit. To provide compatibility with future products, the value of a reserved bit should be preserved across a read-modify-write operation.
16	XOSC	RO	0	Status of external 32.768-kHz oscillator Value Description 0 Default 1 32.768-kHz oscillator has failed
15:4	reserved	RO	0	Software should not rely on the value of a reserved bit. To provide compatibility with future products, the value of a reserved bit should be preserved across a read-modify-write operation.
3	TRIG3	RO	0	Status of TMPR[3] Trigger Value Description 0 Default 1 A tamper event has been detected on TMPR[3]
2	TRIG2	RO	0	Status of TMPR[2] Trigger Value Description 0 Default 1 A tamper event has been detected on TMPR[2]

Bit/Field	Name	Type	Reset	Description
1	TRIG1	RO	0	Status of TMPR[1] Trigger Value Description 0 Default 1 A tamper event has been detected on TMPR[1]
0	TRIG0	RO	0	Status of TMPR[0] Trigger Value Description 0 Default 1 A tamper event has been detected on TMPR[0]

Register 32: Hibernation Peripheral Properties (HIBPP) , offset 0xFC0

This register describes the features available within the Hibernation Module.

Hibernation Peripheral Properties (HIBPP)

Base 0x400F.C000
 Offset 0xFC0
 Type RO, reset 0x0000.0002

	31	30	29	28	27	26	25	24	23	22	21	20	19	18	17	16
	reserved															
Type	RO	RO	RO	RO	RO	RO	RO	RO	RO	RO	RO	RO	RO	RO	RO	RO
Reset	0	0	0	0	0	0	0	0	0	0	0	0	0	0	0	0
	15	14	13	12	11	10	9	8	7	6	5	4	3	2	1	0
	reserved														TAMPER	WAKENC
Type	RO	RO	RO	RO	RO	RO	RO	RO	RO	RO	RO	RO	RO	RO	RO	RO
Reset	0	0	0	0	0	0	0	0	0	0	0	0	0	0	1	0

Bit/Field	Name	Type	Reset	Description
31:2	reserved	RO	0x0	Software should not rely on the value of a reserved bit. To provide compatibility with future products, the value of a reserved bit should be preserved across a read-modify-write operation.
1	TAMPER	RO	0x1	Tamper Pin Presence Value Description 0 Tamper module is not present. 1 Tamper module is present.
0	WAKENC	RO	0x0	Wake Pin Presence Value Description 0 $\overline{\text{WAKE}}$ pin is present. 1 $\overline{\text{WAKE}}$ pin is not part of the package pinout.

Register 33: Hibernation Clock Control (HIBCC), offset 0xFC8

This register enables alternate clock sources.

Note: This register is in the system clock domain. Writes to this register do not require waiting for the `WRC` bit of the `HIBCTL` register to be set.

Hibernation Clock Control (HIBCC)

Base 0x400F.C000

Offset 0xFC8

Type RW, reset 0x0000.0000

	31	30	29	28	27	26	25	24	23	22	21	20	19	18	17	16
	reserved															
Type	RO	RO	RO	RO	RO	RO	RO	RO	RO	RO	RO	RO	RO	RO	RO	RO
Reset	0	0	0	0	0	0	0	0	0	0	0	0	0	0	0	0
	15	14	13	12	11	10	9	8	7	6	5	4	3	2	1	0
	reserved															SYSCLKEN
Type	RO	RO	RO	RO	RO	RO	RO	RO	RO	RO	RO	RO	RO	RO	RO	RW
Reset	0	0	0	0	0	0	0	0	0	0	0	0	0	0	0	0

Bit/Field	Name	Type	Reset	Description
31:1	reserved	RO	0x0000	Software should not rely on the value of a reserved bit. To provide compatibility with future products, the value of a reserved bit should be preserved across a read-modify-write operation.
0	SYSCLKEN	RW	0x0	<p>RTCOSC to System Clock Enable</p> <p>This bit RTCOSC clock to be sent to the system control for selection as a possible system clock source. Default mode is disabled to support low power modes.</p> <p>Value Description</p> <p>0 RTCOSC is not available as a system clock source.</p> <p>1 RTCOSC is available for use as a system clock source.</p>

8 Internal Memory

The TM4C129ENC PDT microcontroller comes with 256 KB of bit-banded SRAM, internal ROM, 1024 KB of Flash memory, and 6KB of EEPROM.

The TM4C129ENC PDT microcontroller provides 1024 KB of on-chip Flash memory. The Flash memory is configured as four banks of 16K x 128 bits (4 * 256 KB total) which are two-way interleaved. Memory blocks can be marked as read-only or execute-only, providing different levels of code protection. Read-only blocks cannot be erased or programmed, protecting the contents of those blocks from being modified. Execute-only blocks cannot be erased or programmed, and can only be read by the controller instruction fetch mechanism, protecting the contents of those blocks from being read by either the controller or by a debugger.

The TM4C129ENC PDT microcontroller provides enhanced performance and power savings by implementation of two sets of instruction prefetch buffers. Each prefetch buffer is 2 x 256 bits and can be combined as a 4 x 256-bit prefetch buffer.

The EEPROM module provides a well-defined register interface to support accesses to the EEPROM with both a random access style of read and write as well as a rolling or sequential access scheme. A password model allows the application to lock one or more EEPROM blocks to control access on 16-word boundaries.

8.1 Block Diagram

Figure 8-1 on page 609 illustrates the internal memory and control structure . The dashed box in the figure indicate registers residing in the System Control module.

Figure 8-1. Internal Memory Block Diagram

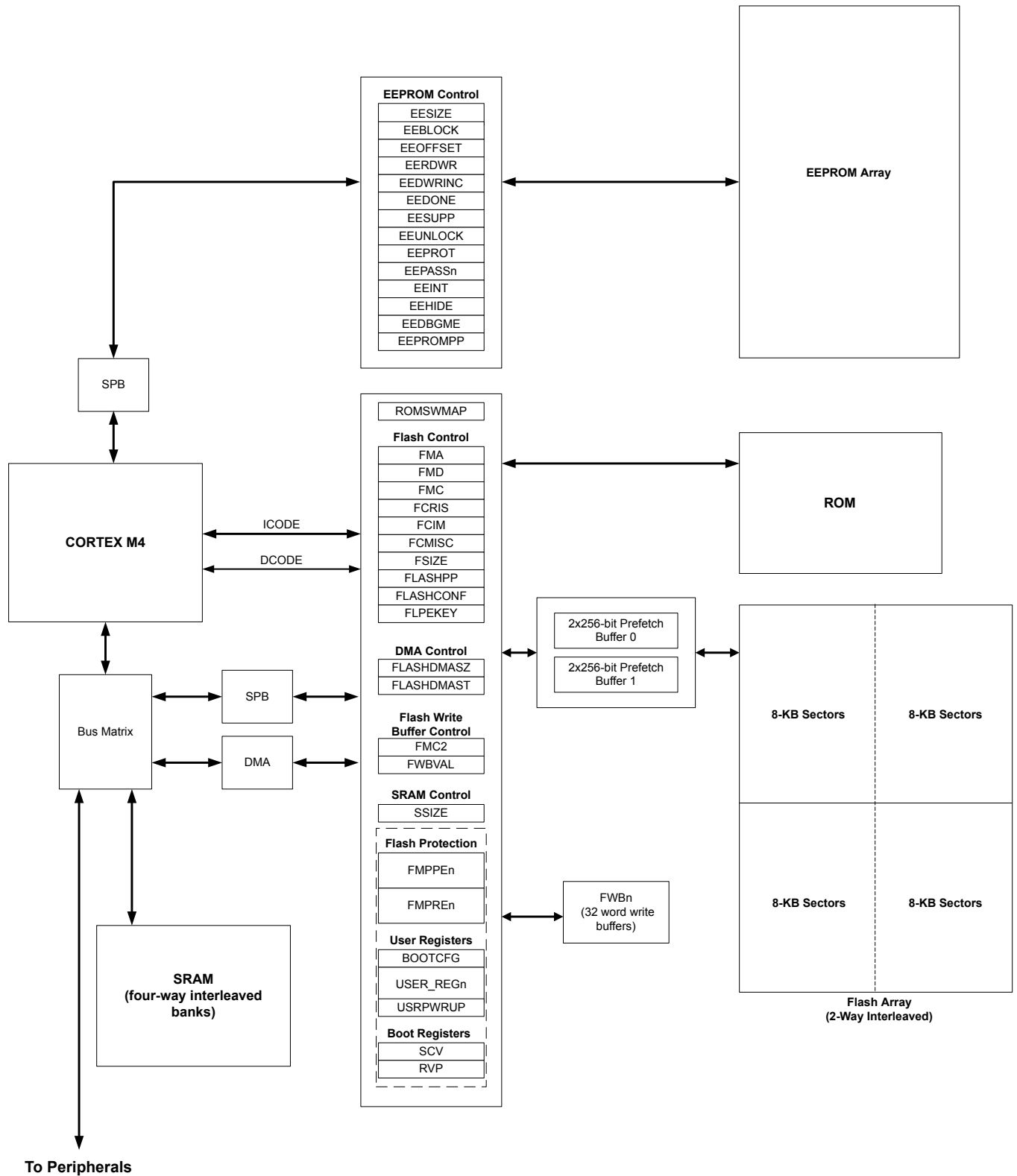

8.2 Functional Description

This section describes the functionality of the SRAM, ROM, Flash, and EEPROM memories.

Note: The μ DMA has read-only access to flash (in Run Mode only).

8.2.1 SRAM

The internal system SRAM of the Tiva™ C Series devices is located at address 0x2000.0000 of the device memory map. To reduce the number of time consuming read-modify-write (RMW) operations, ARM provides bit-banding technology in the processor. With a bit-band-enabled processor, certain regions in the memory map (SRAM and peripheral space) can use address aliases to access individual bits in a single, atomic operation. The bit-band base is located at address 0x2200.0000.

The bit-band alias is calculated by using the formula:

$$\text{bit-band alias} = \text{bit-band base} + (\text{byte offset} * 32) + (\text{bit number} * 4)$$

For example, if bit 3 at address 0x2000.1000 is to be modified, the bit-band alias is calculated as:

$$0x2200.0000 + (0x1000 * 32) + (3 * 4) = 0x2202.000C$$

With the alias address calculated, an instruction performing a read/write to address 0x2202.000C allows direct access to only bit 3 of the byte at address 0x2000.1000.

For details about bit-banding, see “Bit-Banding” on page 115.

Note: The SRAM is implemented using four-way 32-bit wide interleaved SRAM banks (separate SRAM arrays) which allow for increased speed between memory accesses. When using interleaving, a write to one bank followed by a read of another bank can occur in successive clock cycles without incurring any delay. However, a write access that is followed immediately by a read access to the same bank incurs a stall of a single clock cycle.

The SRAM memory layout allows for multiple masters to access different SRAM banks simultaneously. If two masters attempt to access the same SRAM bank, the master with the higher priority gains access to the memory bus and the master with the lower priority is stalled by one wait state. If four masters attempt to access the same SRAM bank, access by the master with the lowest priority is delayed by three wait states. The CPU core always has the highest priority for SRAM memory accesses.

8.2.2 ROM

The internal ROM of the Tiva™ C Series device is located at address 0x0100.0000 of the device memory map. Detailed information on the ROM contents can be found in the *Tiva™ C Series TM4C129x ROM User's Guide* (literature number [SPMU363](#)).

The ROM contains the following components:

- TivaWare™ Boot Loader and vector table
- TivaWare Peripheral Driver Library (DriverLib) release for product-specific peripherals and interfaces
- Advanced Encryption Standard (AES) cryptography tables
- Cyclic Redundancy Check (CRC) error detection functionality

The boot loader is used as an initial program loader (when the Flash location 0x0000.0004, the reset vector location is all 1s (that is, erased state of Flash)) as well as an application-initiated

firmware upgrade mechanism (by calling back to the boot loader). The Peripheral Driver Library APIs in ROM can be called by applications, reducing Flash memory requirements and freeing the Flash memory to be used for other purposes (such as additional features in the application). Advanced Encryption Standard (AES) is a publicly defined encryption standard used by the U.S. Government. Cyclic Redundancy Check (CRC) is a technique to validate whether a block of data has the same contents as when previously checked.

Note: CRC and AES software programs are available in TivaWare for backward-compatibility. A device that has enhanced CRC and AES integrated modules should utilize this hardware for best performance. Please refer to “Cyclical Redundancy Check (CRC)” on page 954 and “Advance Encryption Standard Accelerator (AES)” on page 963 for more information.

8.2.2.1 Boot Configuration

After Power-On-Reset (POR) and device initialization occurs, the hardware loads the stack pointer from either flash or ROM based on the presence of an application in flash and the state of the `EN` bit in the `BOOTCFG` register. If the flash address 0x0000.0004 contains an erased word (value 0xFFFF.FFFF) or the `EN` bit is of the `BOOTCFG` register is clear, the stack pointer and reset vector pointer are loaded from ROM at address 0x0100.0000 and 0x0100.0004, respectively. The boot loader executes and configures the available boot slave interfaces and waits for an external memory to load its software. The boot loader uses a simple packet interface to provide synchronous communication with the device. The speed of the boot loader is determined by the internal oscillator (PIOSC) frequency. The following serial interfaces can be used:

- UART0
- SSI0
- I²C0
- USB

If the check of the Flash at address 0x0000.0004 contains a valid reset vector value and the `EN` bit in the `BOOTCFG` register is set, the stack pointer and reset vector values are fetched from the beginning of flash. This application stack pointer and reset vector are loaded and the processor executes the application directly. Otherwise, the stack pointer and reset vector values are fetched from the beginning of ROM.

8.2.2.2 TivaWare Peripheral Driver Library

The TivaWare Peripheral Driver Library contains a file called `driverlib/rom.h` that assists with calling the peripheral driver library functions in the ROM. The detailed description of each function is available in the *Tiva™ C Series TM4C129x ROM User's Guide (literature number SPMU363)*. See the "Using the ROM" chapter of the *TivaWare™ Peripheral Driver Library for C Series User's Guide (literature number SPMU298)* for more details on calling the ROM functions and using `driverlib/rom.h`.

A table at the beginning of the ROM points to the entry points for the APIs that are provided in the ROM. Accessing the API through these tables provides scalability; while the API locations may change in future versions of the ROM, the API tables do not. The tables are split into two levels; the main table contains one pointer per peripheral which points to a secondary table that contains one pointer per API that is associated with that peripheral. The main table is located at 0x0100.0010, right after the Cortex-M4F vector table in the ROM.

DriverLib functions are described in detail in the *TivaWare™ Peripheral Driver Library for C Series User's Guide (literature number SPMU298)*.

Additional APIs are available for graphics and USB functions, but are not preloaded into ROM. The TivaWare Graphics Library provides a set of graphics primitives and a widget set for creating graphical

user interfaces on Tiva™ C Series microcontroller-based boards that have a graphical display (for more information, see the *TivaWare™ Graphics Library for C Series User's Guide (literature number SPMU300)*). The TivaWare USB Library is a set of data types and functions for creating USB Device, Host or On-The-Go (OTG) applications on Tiva™ C Series microcontroller-based boards (for more information, see the *TivaWare™ USB Library for C Series User's Guide (literature number SPMU297)*).

8.2.2.3 Advanced Encryption Standard (AES) Cryptography Tables

AES is a strong encryption method with reasonable performance and size. AES is fast in both hardware and software, is fairly easy to implement, and requires little memory. AES is ideal for applications that can use prearranged keys, such as setup during manufacturing or configuration. Four data tables used by the XySSL AES implementation are provided in the ROM. The first is the forward S-box substitution table, the second is the reverse S-box substitution table, the third is the forward polynomial table, and the final is the reverse polynomial table. See the *Tiva™ C Series TM4C129x ROM User's Guide (literature number SPMU363)* for more information on AES.

8.2.2.4 Cyclic Redundancy Check (CRC) Error Detection

The CRC technique can be used to validate correct receipt of messages (nothing lost or modified in transit), to validate data after decompression, to validate that Flash memory contents have not been changed, and for other cases where the data needs to be validated. A CRC is preferred over a simple checksum (for example, XOR all bits) because it catches changes more readily. When device initialization is executing from ROM, a CRC-32 validates the data being transferred into registers and memory. The CRC ensures no instructions were skipped in a sequence or no data was corrupted during transfer. See the *Tiva™ C Series TM4C129x ROM User's Guide (literature number SPMU363)* for more information on CRC.

8.2.3 Flash Memory

The Flash memory is configured in groups of four banks four banks of 16K x 128 bits (4 * 256 KB total) which are two-way interleaved as shown below.

Figure 8-2. Flash Memory Configuration

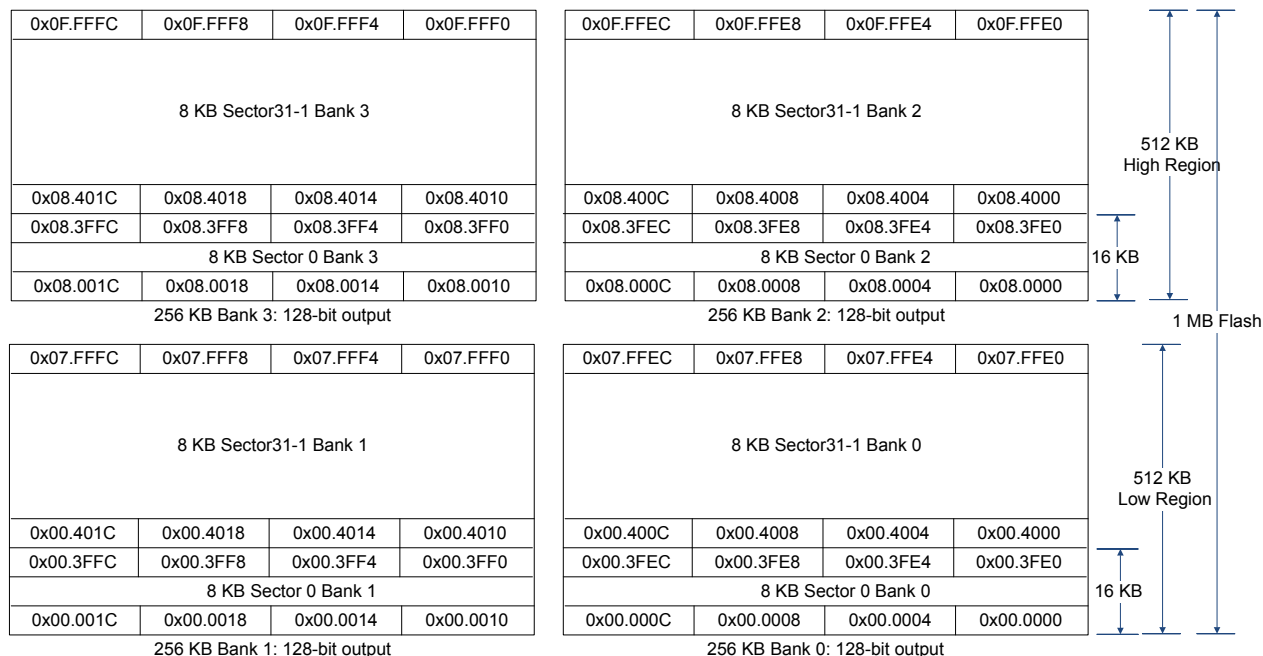

The interleaved memory prefetchs 256 bits at a time. The prefetch buffers allow the maximum performance of a 120 MHz CPU speed to be maintained with linear code or loops that fit within the prefetch buffer. It is recommended that code be compiled with switches set to eliminate "literals" as much as possible as a literal causes a flash access for that word and a stall for the wait states. Most compilers support transforming literals into "in-line" code, which executes faster in a system where the memory subsystem is slower than the CPU.

Because the memory is two-way interleaved and each bank individually is an 8-KB sector, when the user erases a sector, using the `ERASE` bits in the **Flash Memory Control (FMC) register**, it is a 16 KB erase. Erasing a block causes the entire contents of the block to be reset to all 1s.

8.2.3.1 Flash Configuration

Depending on the CPU frequency, the application must program the Flash clock high time (`FBCHT`), Flash Bank Clock Edge (`FBCE`) and Flash wait states (`FWS`) in the **Memory Timing Parameter Register 0 for Main Flash and EEPROM (MEMTIM0)**, System Control Module offset 0x0C0. The following table details the bit field values that are required for the given CPU frequency ranges.

Table 8-1. MEMTIM0 Register Configuration versus Frequency

CPU Frequency range (f) in MHz	Time Period Range (t) in ns	Flash Bank Clock High Time (<code>FBCHT</code>)	Flash Bank Clock Edge (<code>FBCE</code>)	Flash Wait States (<code>FWS</code>)
16	62.5	0x0	1	0x0
16 < f ≤ 40	62.5 > t ≥ 25	0x2	0	0x1
40 < f ≤ 60	25 > t ≥ 16.67	0x3	0	0x2
60 < f ≤ 80	16.67 > t ≥ 12.5	0x4	0	0x3
80 < f ≤ 100	12.5 > t ≥ 10	0x5	0	0x4

Table 8-1. MEMTIM0 Register Configuration versus Frequency (continued)

CPU Frequency range (f) in MHz	Time Period Range (t) in ns	Flash Bank Clock High Time (FBCHT)	Flash Bank Clock Edge (FBCE)	Flash Wait States (FWS)
100 < f ≤ 120	10 > t ≥ 8.33	0x6	0	0x5

To update the **MEMTIM0** register with the new Flash configuration values, the **MEMTIMU** bit should be set in the **Run and Sleep Mode Configuration Register (RSCLKCFG)**, System Control offset 0x0B0.

Note: The associated Flash and EEPROM fields in the **MEMTIM0** register must be programmed to the same values. For example, the **FWS** field must be programmed to the same value as the **EWS** field.

8.2.3.2 Prefetch Buffers

The prefetch buffers can exist as a single set of 2x256-bit buffers or 4x256-bit buffers depending on the **SPFE** bit programmed in the **Flash Configuration Register (FLASHCONF)** register, offset 0xFC8. At reset, all four buffers are enabled. The buffers are filled using a "least-recently-used" (LRU) method. When operating in a single set buffer configuration, the two, 256-bit buffers create a deterministic configuration as each "next" write is sent to the previous buffer that was written. Figure 8-3 on page 614 depicts the single 256-bit buffer set. The single prefetch buffer set should only be used when the code execution must be purely deterministic for the number of clock cycles it takes to execute. Utilizing the four prefetch buffer configuration is the preferred method of configuration.

Figure 8-3. Single 256-Bit Prefetch Buffer Set

Prefetch Buffer 0	TAG	WORD 7	WORD 6	WORD 5	WORD 4	WORD 3	WORD 2	WORD 1	WORD 0
Prefetch Buffer 1	TAG	WORD 7	WORD 6	WORD 5	WORD 4	WORD 3	WORD 2	WORD 1	WORD 0

When the buffers are configured as four, 256-bit buffers, they function as one set, with one of the four buffers tagged as the LRU and the next to be used when an auto-fill or miss occurs.

Figure 8-4. Four 256-Bit Prefetch Buffer Configuration

Prefetch Buffer 0	TAG	WORD 7	WORD 6	WORD 5	WORD 4	WORD 3	WORD 2	WORD 1	WORD 0
Prefetch Buffer 1	TAG	WORD 7	WORD 6	WORD 5	WORD 4	WORD 3	WORD 2	WORD 1	WORD 0
Prefetch Buffer 2	TAG	WORD 7	WORD 6	WORD 5	WORD 4	WORD 3	WORD 2	WORD 1	WORD 0
Prefetch Buffer 3	TAG	WORD 7	WORD 6	WORD 5	WORD 4	WORD 3	WORD 2	WORD 1	WORD 0

The address of the auto-fill is stored in this tag register so that address violations can be identified immediately and miss processing can begin directly. Every **ICODE** access is checked against valid tags to see if the target word is already in the buffers.

If there is a hit, the target word is immediately sent to the CPU with no wait states. If there is a miss, then the prefetch buffer is invalidated and the miss is processed as a 256-bit read from the flash

subsystem to fill the next, least-recently used prefetch buffer. Two memory banks are read in parallel to retrieve 256-bits worth of data.

If an auto-fill has been started and a miss occurs, the auto-fill completes before the miss is processed. If an auto-fill occurs that hits the prefetch buffer being processed for the auto-fill, then the ICODE bus is stalled until the auto fill is complete and new entry can be accessed. For an instruction miss, access to the flash bank starts immediately after the address is available provided the flash sub-system is not already processing a DCODE bus access or a PROGRAM/ERASE operation in the same banks. The target word is passed to the CPU one cycle after it is written to the prefetch buffer.

Figure 8-5 on page 615 shows the timing diagram for a hit in the prefetch buffer.

Figure 8-5. Single Cycle Access, 0 Wait States

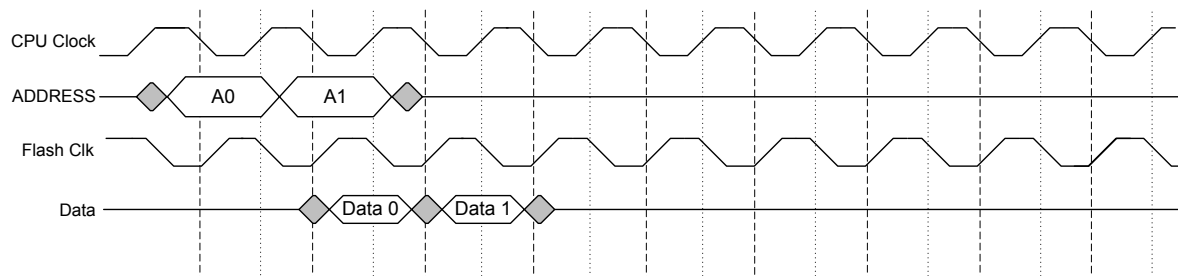

The Flash memory can operate at the CPU clock speed with zero-wait-state accesses when data is resident in the prefetch buffers. When an access does not hit in the prefetch buffer, there is a delay that is incurred while the data is transferred from the Flash. This delay is dependent on the programmed CPU frequency. Refer to Table 8-1 on page 613 for required CPU frequency versus programmed wait-state delay information. Figure 8-6 on page 616 depicts the events that occur as the CPU steps through the words in the prefetch buffer that has just been loaded until it reaches the end of the current prefetch line. The notable events are as follows (refer to Figure 8-6 on page 616):

- **EVENT A:** When the CPU has a miss in the prefetch buffer, a line is fetched from Flash. The target word is written to the prefetch buffer and sent to the CPU one cycle after.
- **EVENT B:** When the CPU reaches Word 3, the next 256-bit buffer line is fetched, resulting in a zero-wait-state access of next line's Word 0
- **EVENT C:** After this word, if the CPU is still executing sequentially, Word 0 of the next buffer line that was fetched is sent to the CPU, with zero-wait-state delay
- **EVENT D:** Word 0 from the second fetch that occurred is sent to the CPU

Figure 8-6. Prefetch Fills from Flash

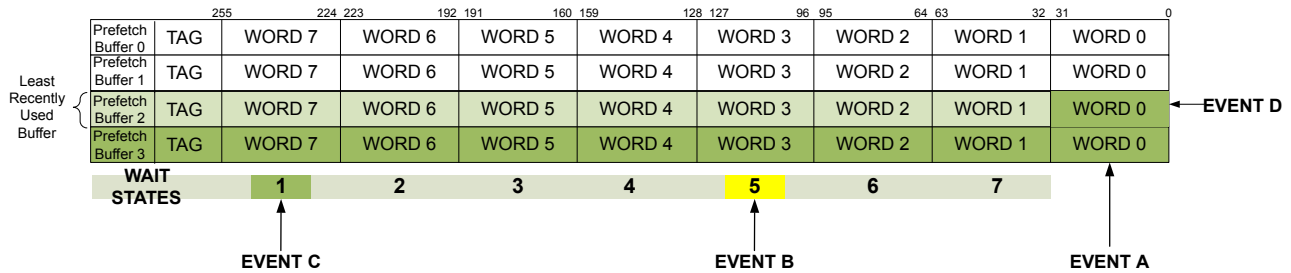

Note that if the CPU target word is beyond Word 2 (Word 3 through Word 7) then the next prefetch fill begins immediately and, depending on the CPU frequency, a delay is incurred between CPU access of Word 7 and Word 0 of the next line.

Note: For optimal prefetch buffer performance, align application code/branches on 8-word boundaries.

Note: Because the prefetch buffers and Flash memory can effectively be utilized at 20 Mhz and above, an application may see an improvement in current consumption from 16 MHz to 20 MHz.

The prefetch buffers can be forced ON and OFF by setting the `FPFON` and `FPFOFF` bits in the **Flash Configuration (FLASHCONF)** register at 0xFC8. If the application sets the `FPFON` or `FPFOFF` bit while the CPU is currently reading or writing to Flash, the prefetch buffer action of turning on or off happens only after the Flash operation has completed. This feature can be used in test modes when determining optimum memory configuration for code.

Prefetch buffer valid tags can be cleared in the following ways:

- Any **Flash Configuration (FLASHCONF)** register changes, such as:
 - Disabling the prefetch buffer by setting the `FPFOFF` bit
 - Setting the `CLRTV` bit to clear the prefetch buffer tags
- A system reset
- ROM accesses
- Error during ICODE accesses
- System aborts
- Mirror mode changes

Note: If the prefetch buffers are enabled and application code branches to a location other than flash memory which then modifies the flash memory, the prefetch tags must be cleared before returning to flash code execution. Prefetch buffer valid tags can be cleared by setting the `CLRTV` bit in the **FLASHCONF** register.

8.2.3.3 Flash Mirror Mode

Flash mirroring allows multiple copies of software to exist in Flash simultaneously. The software can run from the lower banks at the same time software is updating a mirrored copy on the upper bank. In addition to the data, the boot loader in both the lower and upper banks must be mirrored

while programming the flash contents. If data needs to be recovered, a hot swap can be done by setting the FMME bit in the **FLASHCONF** register to ensure the flash banks are idle during the swap. The prefetch buffers must be invalidated during the execution of a hot swap. Next, the address translation logic decodes up to 512 KB from the upper banks to the lower banks. Once the banks are swapped, the mirrored flash image is then used. The address translation logic translates the address to the upper banks until the next swap. Figure 8-7 on page 617 depicts the configuration necessary when executing Flash mirroring.

Note: After a mirror mode has been executed and the code locations have been swapped from the upper memory banks to the lower, the application can continue to read from the lower memory bank address locations. However, when erasing or programming the swapped memory, the application must use the "real" upper memory address of the code before it was swapped. For example, in Figure 8-7 on page 617, when the yellow highlighted location 0x00.3FE8 is swapped with 0x08.3FE8 the application's next read location is 0x00.3FEC. However, if the application were to program or erase the next location it would need to write or erase location 0x08.3FEC

Figure 8-7. Mirror Mode Function

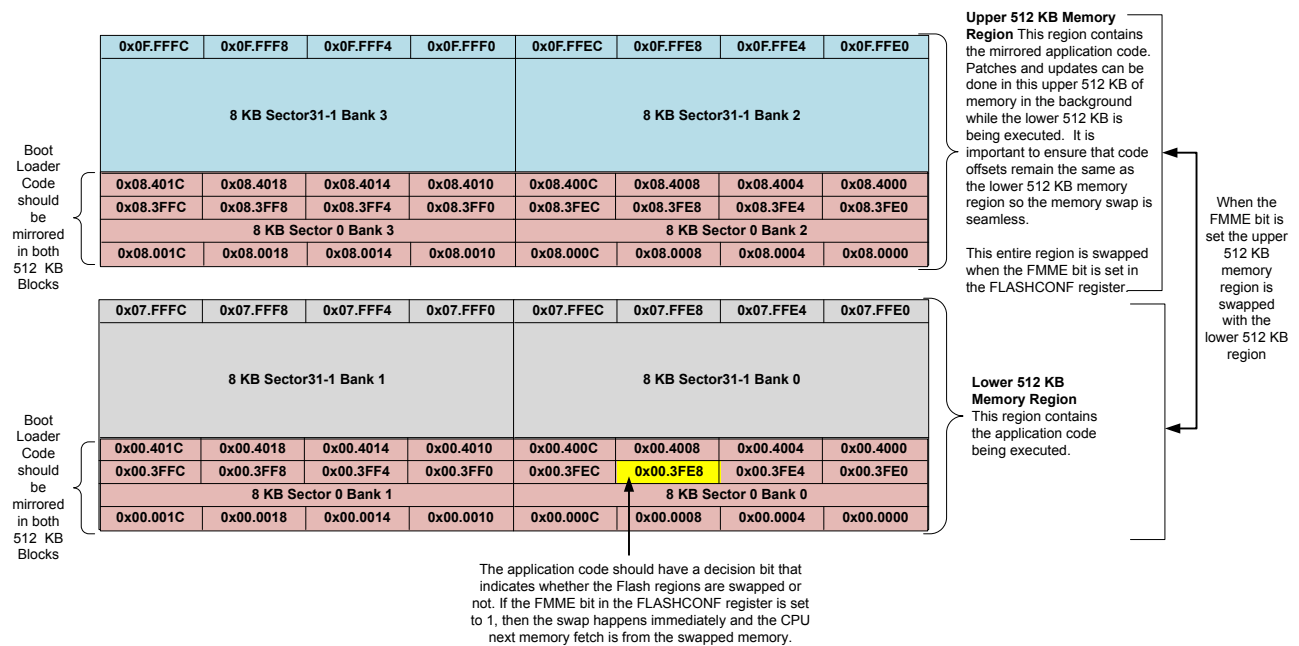

8.2.3.4 Protected Flash Memory Registers

The user is provided execution protection through 16 pairs of 32-bit wide registers. The policy for each protection form is controlled by individual bits (per policy per block) in the **FMPPEn** and **FMPREn** registers.

- Flash Memory Protection Program Enable (FMPPEn):** In the Flash, 16-KB blocks can be individually protected from being programmed or erased. Because each bit of the **FMPPE** register represents a 2-KB block, the application must clear all the bits in one byte to protect one 16-KB block. Execute-only protection can only be programmed in 16-KB increments. For example, to protect the first 16-KB block, bits [7:0] all need to be set to 0s. When bits in the **FMPPEn** register are set, the corresponding block may be programmed (written) or erased. When bits are cleared,

the corresponding block may not be changed. When a block is protected by clearing bits in both **FMPPEn** and **FMPREn** registers, execute-only protection can be achieved.

- **Flash Memory Protection Read Enable (FMPREn):** If a bit is set in this register, the corresponding block may be executed or read by software or debuggers. If a bits in this register are cleared and the same block in the **FMPREn** register is cleared, the corresponding block may only be executed, and contents of the memory block are prohibited from being read as data. **FMPREn** protection can be programmed in 2-KB increments, unlike the **FMPPEn**, which must be programmed in 16-KB increments. However, if an application does want to read-protect a 16-KB block, eight bits need to be written from 1s to 0s.

The policies may be combined as shown in Table 8-2 on page 618.

Table 8-2. Flash Memory Protection Policy Combinations

FMPPEn	FMPREn	Protection
0	0	Execute-only protection. The block may only be executed and may not be written or erased. This mode is used to protect code.
1	0	The block may be written, erased or executed, but not read. This combination is unlikely to be used.
0	1	Read-only protection. The block may be read or executed but may not be written or erased. This mode is used to lock the block from further modification while allowing any read or execute access.
1	1	No protection. The block may be written, erased, executed or read.

A Flash memory access that attempts to read a read-protected block (**FMPREn** bit is clear) is prohibited and generates a bus fault. A Flash memory access that attempts to program or erase a program-protected block (**FMPPEn** bit is clear) is prohibited and can optionally generate an interrupt (by setting the **AMASK** bit in the **Flash Controller Interrupt Mask (FCIM)** register) to alert software developers of poorly behaving software during the development and debug phases.

The factory settings for the **FMPREn** and **FMPPEn** registers are a value of 1 for all implemented banks. These settings create a policy of open access and programmability. The register bits may be changed by clearing the specific register bit. The changes are not permanent until the register is committed (saved), at which point the bit change is permanent. If a bit is changed from a 1 to a 0 and not committed, it may be restored by executing a any simulated power-on-reset (**SIM_POR**) event. The changes are committed using the **Flash Memory Control (FMC)** register. Details on programming these bits are discussed in “Non-Volatile Register Programming-- Flash Memory Resident Registers” on page 621.

8.2.3.5 Execute-Only Protection

Execute-only protection prevents both modification and visibility to a protected flash block. This mode is intended to be used in situations where a device requires debug capability, yet portions of the application space must be protected from external access. An example of this is a company that wishes to sell Tiva™ C Series devices with their proprietary software preprogrammed, yet allow the end user to add custom code to an unprotected region of the flash (such as a motor control module with a customizable motor configuration section in flash).

Literal data introduces a complication to the protection mechanism. When C code is compiled and linked, literal data (constants, and so on) is typically placed in the text section, between functions, by the compiler. The literal data is accessed at run time through the use of the LDR instruction, which loads the data from memory using a PC-relative memory address. The execution of the LDR instruction generates a read transaction across the Cortex-M3's DCode bus, which is subject to the execute-only protection mechanism. If the accessed block is marked as execute only, the transaction

is blocked, and the processor is prevented from loading the constant data and, therefore, inhibiting correct execution. Therefore, using execute-only protection requires that literal data be handled differently. There are three ways to address this:

1. Use a compiler that allows literal data to be collected into a separate section that is put into one or more read-enabled flash blocks. Note that the LDR instruction may use a PC-relative address, in which case the literal pool cannot be located outside the span of the offset, or the software may reserve a register to point to the base address of the literal pool and the LDR offset is relative to the beginning of the pool.
2. Use a compiler that generates literal data from arithmetic instruction immediate data and subsequent computation.
3. Use method 1 or 2, but in assembly language, if the compiler does not support either method.

8.2.3.6 Read-Only Protection

Read-only protection prevents the contents of the flash block from being re-programmed, while still allowing the content to be read by processor or the debug interface. Note that if a **FMPREn** bit is cleared, all read accesses to the Flash memory block are disallowed, including any data accesses. Care must be taken not to store required data in a Flash memory block that has the associated **FMPREn** bit cleared.

The read-only mode does not prevent read access to the stored program, but it does provide protection against accidental (or malicious) erasure or programming. Read-only is especially useful for utilities like the boot loader when the debug interface is permanently disabled. In such combinations, the boot loader, which provides access control to the Flash memory, is protected from being erased or modified.

8.2.3.7 Permanently Disabling Debug

For extremely sensitive applications, the debug interface to the processor and peripherals can be permanently disabled, blocking all accesses to the device through the JTAG or SWD interfaces. With the debug interface disabled, it is still possible to perform standard IEEE instructions (such as boundary scan operations), but access to the processor and peripherals is blocked.

The **DBG0** and **DBG1** bits of the **Boot Configuration (BOOTCFG)** register control whether the debug interface is turned on or off.

The debug interface should not be permanently disabled without providing some mechanism, such as the boot loader, to provide customer-installable updates or bug fixes. Disabling the debug interface is permanent and cannot be reversed.

8.2.3.8 Interrupts

The Flash memory controller can generate interrupts when the following conditions are observed:

- Programming Interrupt: Signals when a program or erase action is complete. (**PRIS**).
- Access Interrupt: Signals when a program or erase action has been attempted on a 16-kB block of memory that is protected by its corresponding **FMPPEn** bit. (**ARIS**).
- EEPROM Interrupt
- Pump Voltage Interrupt: Indicates if the regulated voltage of the pump went out of specification during a Flash operation and the operation was terminated. (**VOLTRIS**).

- Invalid Data Interrupt: Signals when a bit in Flash that was previously programmed as a 0 is now requested to be programmed as a 1. (*INVDRIS*).
- ERASE Operation Interrupt: Indicates an ERASE operation failed. (*ERRIS*).

The interrupt events that can trigger a controller-level interrupt are defined in the **Flash Controller Masked Interrupt Status (FCMIS)** register (see page 641) by setting the corresponding *MASK* bits. If interrupts are not used, the raw interrupt status is always visible via the **Flash Controller Raw Interrupt Status (FCRIS)** register (see page 638).

Interrupts are always cleared (for both the **FCMIS** and **FCRIS** registers) by writing a 1 to the corresponding bit in the **Flash Controller Masked Interrupt Status and Clear (FCMISC)** register (see page 643).

8.2.3.9 μ DMA

The μ DMA can be programmed to read from Flash. The **Flash DMA Address Size (FLASHDMASZ)** register configures 2-KB regions of Flash that can be accessed by the μ DMA. The starting address for this μ DMA-accessible region is defined in the **Flash DMA Starting Address (FLASHDMAST)** register. When the *DFA* bit is set in the **FLASHPP** register, the μ DMA can access the enabled region configured by the **FLASHDMASZ** and **FLASHDMAST** registers. The μ DMA checks the **Flash Protection Program Enable n (FMPPE_n)** registers for masked 2-KB Flash regions before initiating the transfer. If the access is out of range, then a bus fault is generated.

Note: The μ DMA can access Flash in Run Mode only (not available in low power modes).

8.2.3.10 Flash Memory Programming

The Tiva™ C Series devices provide a user-friendly interface for Flash memory programming. All erase/program operations are handled via three registers: **Flash Memory Address (FMA)**, **Flash Memory Data (FMD)**, and **Flash Memory Control (FMC)**. Note that if the debug capabilities of the microcontroller have been deactivated, resulting in a "locked" state, a recovery sequence must be performed in order to reactivate the debug module. See "Recovering a "Locked" Microcontroller" on page 220.

When a Flash memory operation write, page erase, or mass erase is executed in a Flash bank, access to that particular bank pair is inhibited. As a result, instruction and literal fetches to the bank pair are held off until the Flash memory operation is complete. If instruction execution is required during a Flash memory operation, the code that is executing must be placed in SRAM and executed from there while the flash operation is in progress.

Note: When programming Flash memory, the following characteristics of the memory must be considered:

- Only an erase can change bits from 0 to 1.
- A write can only change bits from 1 to 0. If the write attempts to change a 0 to a 1, the write fails and no bits are changed.
- All Flash operations are completed before entering sleep or deep sleep.

To program a 32-bit word

1. Write source data to the **FMD** register.
2. Write the target address to the **FMA** register.

3. Write the Flash memory write key and the `WRITE` bit (a value of 0xA442.0001) to the **FMC** register. The write key may be 0xA442 or the value programmed into the **FLPEKEY** register depending on the `KEY` value in the **BOOTCFG** register. See page 682 and page 648 for more information.
4. Poll the **FMC** register until the `WRITE` bit is cleared.

To perform an erase of a 16-KB sector

1. Write the 16-KB aligned address to the **FMA** register.
2. Write the Flash memory write key and the `ERASE` bit to the **FMC** register.
3. Poll the **FMC** register until the `ERASE` bit is cleared or, alternatively, enable the programming interrupt using the `PMASK` bit in the **FCIM** register.

To perform a mass erase of the Flash memory

1. Write the Flash memory write key and the `MERASE` bit to the **FMC** register.
2. Poll the **FMC** register until the `MERASE` bit is cleared or, alternatively, enable the programming interrupt using the `PMASK` bit in the **FCIM** register.

8.2.3.11 32-Word Flash Memory Write Buffer

A 32-word write buffer provides the capability to perform faster write accesses to the Flash memory by programming two 32-bit words at a time, allowing 32 words to be programmed in the same time as 16 would take using the method described above. The data for the buffered write is written to the **Flash Write Buffer (FWBn)** registers.

The registers are 32-word aligned with Flash memory, and therefore the register **FWB0** corresponds with the address in **FMA** where bits [6:0] of **FMA** are all 0. **FWB1** corresponds with the address in **FMA** + 0x4 and so on. Only the **FWBn** registers that have been updated since the previous buffered Flash memory write operation are written. The **Flash Write Buffer Valid (FWBVAL)** register shows which registers have been written since the last buffered Flash memory write operation. This register contains a bit for each of the 32 **FWBn** registers, where bit[n] of **FWBVAL** corresponds to **FWBn**. The **FWBn** register has been updated if the corresponding bit in the **FWBVAL** register is set.

To program 32 words with a single buffered Flash memory write operation

1. Write the source data to the **FWBn** registers.
2. Write the target address to the **FMA** register. This must be a 32-word aligned address (that is, bits [6:0] in **FMA** must be 0s).
3. Write the Flash memory write key and the `WRBUF` bit to the **FMC2** register.
4. Poll the **FMC2** register until the `WRBUF` bit is cleared or wait for the `PMIS` interrupt to be signaled.

8.2.3.12 Non-Volatile Register Programming-- Flash Memory Resident Registers

Note: The **Boot Configuration (BOOTCFG)** register requires a POR before the committed changes take effect.

This section discusses how to update the registers shown in Table 8-3 on page 622, which are resident within the Flash Memory. These registers exist in a separate space from the main Flash

memory array and are not affected by an ERASE or MASS ERASE operation. The bits in these registers can be changed from 1 to 0 with a commit operation. The register contents are unaffected by any reset condition except power-on reset, which returns the register contents to 0xFFFF.FFFE for the **BOOT Configuration (BOOTCFG)** register and 0xFFFF.FFFF for all others.

By committing the register values using the **COMT** bit in the **Flash Memory Control (FMC)** register, the register contents become non-volatile and are therefore retained following power cycling. Once the register contents are committed, the only way to restore the factory default values is to perform the sequence described in “Recovering a “Locked” Microcontroller” on page 220.

All of the **FMPREn**, **FMPPEn** and **USER_REGn** registers, in addition to the **BOOTCFG** register can be committed in non-volatile memory. The **FMPREn**, **FMPPEn**, and **USER_REGn** registers can be tested before being committed; the **BOOTCFG** register cannot. To program the **BOOTCFG** register, the value must be written into the **Flash Memory Data (FMD)** register before it is committed. The **BOOTCFG** configuration cannot be tried and verified before committing to non-volatile memory.

Important: All Flash memory resident registers can only have bits changed from 1 to 0 by user programming. The **FMPREn**, **FMPPEn** and **BOOTCFG** registers can be committed multiple times, but the **USER_REGn** registers can only be committed once, after the entire register has been set to 1s. After being committed, the **USER_REGn** registers can only be returned to their factory default values of all 1s by performing the sequence described in “Recovering a “Locked” Microcontroller” on page 220. The mass erase of the main Flash memory array caused by the sequence is performed prior to restoring these registers.

Table 8-3 on page 622 provides the **FMA** address required for commitment of each of the registers and the source of the data to be written when the **FMC** register is written with a key value of 0xA442 or the **PEKEY** value of the **FLPEKEY** register. The key value used is determined by the **KEY** bit in the **BOOTCFG** register at reset. If the **KEY** value is 0x0, the **PEKEY** value in the **FLPEKEY** register is used for commits in the **FMC/FMC2** register. If the **KEY** value is 0x1, the value 0xA442 is used as the **WRKEY** in the **FMC/FMC2** register. If the **COMT** bit is set, the user may poll the **FMC** register to wait for the commit operation to complete.

Note: To ensure non-volatile register data integrity, non-volatile register commits should not be interrupted with a power loss. If data integrity is compromised during a commit because of a power loss, a toggle mass erase function can be performed to clear these registers. See Table 8-3 on page 622 for the list of non-volatile registers.

Table 8-3. User-Programmable Flash Memory Resident Registers

Register to be Committed	FMA Value	Data Source
FMPRE0	0x0000.0000	FMPRE0
FMPRE1	0x0000.0002	FMPRE1
FMPRE2	0x0000.0004	FMPRE2
FMPRE3	0x0000.0006	FMPRE3
FMPRE4	0x0000.0008	FMPRE4
FMPRE5	0x0000.000A	FMPRE5
FMPRE6	0x0000.000C	FMPRE6
FMPRE7	0x0000.000E	FMPRE7
FMPRE8	0x0000.0010	FMPRE8
FMPRE9	0x0000.0012	FMPRE9
FMPRE10	0x0000.0014	FMPRE10

Table 8-3. User-Programmable Flash Memory Resident Registers (continued)

Register to be Committed	FMA Value	Data Source
FMPRE11	0x0000.0016	FMPRE11
FMPRE12	0x0000.0018	FMPRE12
FMPRE13	0x0000.001A	FMPRE13
FMPRE14	0x0000.001C	FMPRE14
FMPRE15	0x0000.001E	FMPRE15
FMPPE0	0x0000.0001	FMPPE0
FMPPE1	0x0000.0003	FMPPE1
FMPPE2	0x0000.0005	FMPPE2
FMPPE3	0x0000.0007	FMPPE3
FMPPE4	0x0000.0009	FMPPE4
FMPPE5	0x0000.000B	FMPPE5
FMPPE6	0x0000.000D	FMPPE6
FMPPE7	0x0000.000F	FMPPE7
FMPPE8	0x0000.00011	FMPPE8
FMPPE9	0x0000.00013	FMPPE9
FMPPE10	0x0000.00015	FMPPE10
FMPPE11	0x0000.00017	FMPPE11
FMPPE12	0x0000.00019	FMPPE12
FMPPE13	0x0000.0001B	FMPPE13
FMPPE14	0x0000.0001D	FMPPE14
FMPPE15	0x0000.0001F	FMPPE15
USER_REG0	0x8000.0000	USER_REG0
USER_REG1	0x8000.0001	USER_REG1
USER_REG2	0x8000.0002	USER_REG2
USER_REG3	0x8000.0003	USER_REG3
BOOTCFG	0x7510.0000	FMD

8.2.4 EEPROM

The TM4C129ENCPDT microcontroller includes an EEPROM with the following features:

- 6Kbytes of memory accessible as 1536 32-bit words
- 96 blocks of 16 words (64 bytes) each
- Built-in wear leveling
- Access protection per block
- Lock protection option for the whole peripheral as well as per block using 32-bit to 96-bit unlock codes (application selectable)
- Interrupt support for write completion to avoid polling
- Endurance of 500K writes (when writing at fixed offset in every alternate page in circular fashion) to 15M operations (when cycling through two pages) per each 2-page block.

8.2.4.1 Functional Description

The EEPROM module provides a well-defined register interface to support accesses to the EEPROM with both a random access style of read and write as well as a rolling or sequential access scheme.

A protection mechanism allows locking EEPROM blocks to prevent writes under a set of circumstances as well as reads under the same or different circumstances. The password model allows the application to lock one or more EEPROM blocks to control access on 16-word boundaries.

Blocks

There are 96 blocks of 16 words each in the EEPROM. These are readable and writable as words. Bytes and half-words can be read, and these accesses do not have to occur on a word boundary. The entire word is read and any unneeded data is simply ignored. The EEPROM blocks are writable only on a word basis. To write a byte, it is necessary to read the word value, modify the appropriate byte, and write the word back.

Each block is addressable as an offset within the EEPROM, using a block select register. Each word is offset addressable within the selected block.

The current block is selected by the **EEPROM Current Block (EEBLOCK)** register. The current offset is selected and checked for validity by the **EEPROM Current Offset (EEOFFSET)** register. The application may write the **EEOFFSET** register any time, and it is also automatically incremented when the **EEPROM Read-Write with Increment (EERDWRINC)** register is accessed. However, the **EERDWRINC** register does not increment the block number, but instead wraps within the block.

Blocks are individually protectable. Attempts to read from a block for which the application does not have permission return 0xFFFF.FFFF. Attempts to write into a block for which the application does not have permission results in an error in the **EEPROM Done Status (EEDONE)** register.

Timing Considerations

After enabling or resetting the EEPROM module, software must wait until the `WORKING` bit in the **EEDONE** register is clear before accessing any EEPROM registers.

Note: Software must ensure there are no Flash memory writes or erases pending before performing an EEPROM operation. When the **FMC** register reads as 0x0000.00000 and the `WRBUF` bit of the **FMC2** register is clear, there are no Flash memory writes or erases pending.

EEPROM operations must be completed before entering Sleep or Deep-Sleep mode. Ensure the EEPROM operations have completed by checking the **EEPROM Done Status (EEDONE)** register before issuing a `WFI` instruction to enter Sleep or Deep-Sleep.

Writes to words within a block are delayed by a variable amount of time. The application may use an interrupt to be notified when the write is done, or alternatively poll for the done status in the **EEDONE** register. The variability ranges from the write timing of the EEPROM to the erase timing of EEPROM, where the erase timing is less than the write timing of most external EEPROMs.

Depending on the CPU frequency, the application must program the EEPROM Clock High Time (`EBCHT`), EEPROM Bank Clock Edge (`EBCE`) and the EEPROM Wait States (`EWS`) in the **Memory Timing Parameter Register 0 for Main Flash and EEPROM (MENTIM0)** register at System Control Module offset 0x0C0.

Table 8-4. MEMTIM0 Register Configuration versus Frequency

CPU Frequency range (f) in MHz	Time Period Range (t) in ns	EEPROM Bank Clock High Time (EBCHT)	EEPROM Bank Clock Edge (EBCE)	EEPROM Wait States (EWS)
16	62.5	0x0	1	0x0
16 < f ≤ 40	62.5 > t ≥ 25	0x2	0	0x1
40 < f ≤ 60	25 > t ≥ 16.67	0x3	0	0x2
60 < f ≤ 80	16.67 > t ≥ 12.5	0x4	0	0x3
80 < f ≤ 100	12.5 > t ≥ 10	0x5	0	0x4
100 < f ≤ 120	10 > t ≥ 8.33	0x6	0	0x5

Note: The associated Flash and EEPROM fields in the **MEMTIM0** register must be programmed to the same values. For example, the **FWS** field must be programmed to the same value as the **EWS** field.

Locking and Passwords

The EEPROM can be locked at both the module level and the block level. The lock is controlled by a password that is stored in the **EEPROM Password (EEPASSn)** registers and can be any 32-bit to 96-bit value other than all 1s. Block 0 is the master block, the password for block 0 protects the control registers as well as all other blocks. Each block can be further protected with a password for that block.

If a password is registered for block 0, then the whole module is locked at reset. As a result, the **EEBLOCK** register cannot be changed from 0 until block 0 is unlocked.

A password registered with any block, including block 0, allows for protection rules that control access of that block based on whether it is locked or unlocked. Generally, the lock can be used to prevent write accesses when locked or can prevent read and write accesses when locked.

All password protected blocks are locked at reset. To unlock a block, the correct password value must be written to the **EEPROM Unlock (EEUNLOCK)** register by writing to it once, twice, or three times, depending on the size of the password. A block or the module may be re-locked by writing 0xFFFF.FFFF to the **EEUNLOCK** register because 0xFFFF.FFFF is not a valid password.

Protection and Access Control

The **PROT** protection field in the **EEPROM Protection (EEPROT)** register provides discrete control of read and write access for each block which allows various protection models per block. The protection configurations allowed are as follows:

- **PROT = 0x0**
 - Without password: Readable and writable at any time. This mode is the default when there is no password.
 - With password: Readable, but only writable when unlocked by the password. This mode is the default when there is a password.
- **PROT = 0x1**
 - With password: Readable or writable only when unlocked.
 - This value has no meaning when there is no password.

- PROT = 0x2
 - Without password: Readable but not writable.
 - With password: Readable only when unlocked, not writable under any conditions.

Additionally, access protection may be applied based on the processor mode. This configuration allows for supervisor-only access or supervisor and user access, which is the default. Supervisor-only access mode also prevents access by the μ DMA and Debugger.

Additionally, the master block may be used to control access protection for the protection mechanism itself. If access control for block 0 is for supervisor only, then the whole module may only be accessed in supervisor mode.

Hidden Blocks

Hiding provides a temporary form of protection. Every block except block 0 can be hidden, which prevents all accesses until the next reset.

This mechanism can allow a boot or initialization routine to access some data which is then made inaccessible to all further accesses. Because boot and initialization routines control the capabilities of the application, hidden blocks provide a powerful isolation of the data when debug is disabled.

A typical use model would be to have the initialization code store passwords, keys, and/or hashes to use for verification of the rest of the application. Once performed, the block is then hidden and made inaccessible until the next reset which then re-enters the initialization code.

Power and Reset Safety

Once the **EEDONE** register indicates that a location has been successfully written, the data is retained until that location is written again. There is no power or reset race after the **EEDONE** register indicates a write has completed.

Interrupt Control

The EEPROM module allows for an interrupt when a write completes to prevent the use of polling. The interrupt can be used to drive an application ISR which can then write more words or verify completion. The interrupt mechanism is used any time the **EEDONE** register goes from working to done, whether because of an error or the successful completion of a program or erase operation. This interrupt mechanism works for data writes, writes to password and protection registers, and mass erase using the **EEPROM Debug Mass Erase (EEDGBME)** register. The EEPROM interrupt is signaled to the core using the Flash memory interrupt vector. Software can determine that the source of the interrupt was the EEPROM by examining bit 2 of the **Flash Controller Masked Interrupt Status and Clear (FCMISC)** register.

Theory of Operation

The EEPROM operates using a traditional bank model which implements EEPROM-type cells, but uses sector erase. Additionally, words are replicated in the blocks to allow 500K+ erase cycles when needed, which means that each word has a latest version. As a result, a write creates a new version of the word in a new location, making the previous value obsolete. When a block runs out of room to store the latest version of a word, a copy buffer is used. The copy buffer copies the latest words of each block. The original block is then erased. Finally, the copy buffer contents are copied back to the block.

The EEPROM module includes functionality to prevent data corruption due to power-loss or a brown-out event during programming or erase operations. These conditions prevent corruption of

non-targeted memory areas but cannot guarantee that the operation is completed successfully. Refer to “EEPROM” on page 1972 for important timing information on EEPROM protection. The EEPROM mechanism properly tracks all state information to provide complete safety and protection. Although it should not normally be possible, errors during programming can occur in certain circumstances, for example, the voltage rail dropping during programming. In these cases, the **EESUPP** register can be used to know if a program or an erase had failed.

Debug Mass Erase

The EEPROM debug mass erase allows the developer to mass erase the EEPROM. For the mass erase to occur correctly, there can be no active EEPROM operations. After the last EEPROM operation, the application must ensure that no EEPROM registers are updated, including modifying the **EEBLOCK** and the **EEOFFSET** registers without doing an actual read or write operation. To hold off these operations, the application should reset the EEPROM module by setting the **R0** bit in the **EEPROM Software Reset (SREEPROM)** register, wait until **WORKING** bit in the **EEPROM Done Status (EEDONE)** register is clear, and then enable the debug mass erase by setting the **ME** bit in the **EEPROM Debug Mass Erase (EEDBGME)** register.

Error During Programming

Operations such as data-write, password set, protection set, and copy buffer erase may perform multiple operations. For example, a normal write performs two underlying writes: the control word write and the data write. If the control word writes but the data fails (for example, due to a voltage drop), the overall write fails with indication provided in the **EEDONE** register. Failure and the corrective action is broken down by the type of operation:

- If a normal write fails such that the control word is written but the data fails to write, the safe course of action is to retry the operation once the system is otherwise stable, for example, when the voltage is stabilized. After the retry, the control word and write data are advanced to the next location.
- If a password or protection write fails, the safe course of action is to retry the operation once the system is otherwise stable. In the event that multi-word passwords may be written outside of a manufacturing or bring-up mode, care must be taken to ensure all words are written in immediate succession. If not, then partial password unlock would need to be supported to recover.
- If the word write requires the block to be written to the copy buffer, then it is possible to fail or lose power during the subsequent operations. A control word mechanism is used to track what step the EEPROM was in if a failure occurs. If not completed, the **EESUPP** register indicates the partial completion.

After a reset and prior to writing any data to the EEPROM, software must read the **EESUPP** register and check for the presence of any error condition which may indicate that a write or erase was in progress when the system was reset due to a voltage drop. If either the **PRETRY** or **ERETRY** bits are set, the peripheral should be reset by setting and then clearing the **R0** bit in the **EEPROM Software Reset (SREEPROM)** register and waiting for the **WORKING** bit in the **EEDONE** register to clear before again checking the **EESUPP** register for error indicators. This procedure should allow the EEPROM to recover from the write or erase error. In very isolated cases, the **EESUPP** register may continue to register an error after this operation, in which case the reset should be repeated. After recovery, the application should rewrite the data which was being programmed when the initial failure occurred.

Soft Reset Handling

The following soft resets should not be asserted during an EEPROM program or erase operation:

- Software reset (SYSRESREQ)
- Software peripheral reset
- Watchdog reset (if configured as a system reset in the **RESBEHAVCTL** register)
- MOSC failure reset
- BOR reset (if configured as a system reset in the **RESBEHAVCTL** register)
- External reset (if configured as a system reset in the **RESBEHAVCTL** register)
- Writes to the **HSSR** register

The **WORKING** bit of the **EEDONE** register can be checked before the reset is asserted to see if an EEPROM program or erase operation is occurring. Soft resets may occur when using a debugger and should be avoided during an EEPROM operation. A reset such as the Watchdog reset can be mapped to an external reset using a GPIO, or Hibernate can be entered, if time is not a concern.

Endurance

Endurance is per meta-block which is 8 blocks. Endurance is measured in two ways:

1. To the application, it is the number of writes that can be performed.
2. To the microcontroller, it is the number of erases that can be performed on the meta-block.

Because of the second measure, the number of writes depends on how the writes are performed. For example:

- One word can be written more than 500K times, but, these writes impact the meta-block that the word is within. As a result, writing one word 500K times, then trying to write a nearby word 500K times is not assured to work. To ensure success, the words should be written more in parallel.
- All words can be written in a sweep with a total of more than 500K sweeps which updates all words more than 500K times.
- Different words can be written such that any or all words can be written more than 500K times when write counts per word stay about the same. For example, offset 0 could be written 3 times, then offset 1 could be written 2 times, then offset 2 is written 4 times, then offset 1 is written twice, then offset 0 is written again. As a result, all 3 offsets would have 4 writes at the end of the sequence. This kind of balancing within 7 writes maximizes the endurance of different words within the same meta-block.

8.2.4.2 EEPROM Initialization and Configuration

Before writing to any EEPROM registers, the clock to the EEPROM module must be enabled through the **EEPROM Run Mode Clock Gating Control (RCGCEEPROM)** register (see page 407) and the following initialization steps must be executed:

1. Insert delay (6 cycles plus function call overhead).
2. Poll the **WORKING** bit in the **EEPROM Done Status (EEDONE)** register until it is clear, indicating that the EEPROM has completed its power-on initialization. When **WORKING=0**, continue.

3. Read the `PRETRY` and `ERETRY` bits in the **EEPROM Support Control and Status (EESUPP)** register. If either of the bits are set, return an error, else continue.
4. Reset the EEPROM module using the **EEPROM Software Reset (SREEPROM)** register at offset 0x558 in the System Control register space.
5. Insert delay (6 cycles plus function call overhead).
6. Poll the `WORKING` bit in the **EEPROM Done Status (EEDONE)** register to determine when it is clear. When `WORKING=0`, continue.
7. Read the `PRETRY` and `ERETRY` bits in the **EESUPP** register. If either of the bits are set, return an error, else the EEPROM initialization is complete and software may use the peripheral as normal.

Important: Failure to perform these initialization steps after a reset may lead to incorrect operation or permanent data loss if the EEPROM is later written.

If the `PRETRY` or `ERETRY` bits are set in the **ESUPP** register, the EEPROM was unable to recover its state. If power is stable when this occurs, this indicates a fatal error and is likely an indication that the EEPROM memory has exceeded its specified lifetime write/erase specification. If the supply voltage is unstable when this return code is observed, retrying the operation once the voltage is stabilized may clear the error.

The EEPROM initialization function code is named `EEPROMInit()` in TivaWare, which can be downloaded from <http://www.ti.com/tivaware>.

8.2.5 Bus Matrix Memory Accesses

The following table identifies the Bus Masters and their access to the various memories on the bus matrix.

Table 8-5. Master Memory Access Availability

Master	Flash Access	ROM Access	SRAM Access	EEPROM Access	External Memory Access (via EPI)
CPU Instruction Bus	Yes	Yes (read-only)	Yes	Yes	Yes
CPU Data Bus	Yes	Yes (read-only)	-	Yes	Yes
μDMA	Yes (read-only, Run-Mode-only)	-	Yes	Yes	Yes
Ethernet Module	-	-	Yes	-	-
USB	-	-	Yes	-	-

8.3 Register Map

Table 8-6 on page 630 lists the ROM Controller register and the Flash memory control registers. The offset listed is a hexadecimal increment to the register's address. The Flash memory register offsets are relative to the Flash memory control base address of 0x400F.D000. The EEPROM registers are relative to the EEPROM base address of 0x400A.F000. The ROM control and Flash memory protection register offsets are relative to the System Control base address of 0x400F.E000.

Table 8-6. Flash Register Map

Offset	Name	Type	Reset	Description	See page
Internal Memory Registers (Internal Memory Control Offset)					
0x000	FMA	RW	0x0000.0000	Flash Memory Address	633
0x004	FMD	RW	0x0000.0000	Flash Memory Data	634
0x008	FMC	RW	0x0000.0000	Flash Memory Control	635
0x00C	FCRIS	RO	0x0000.0000	Flash Controller Raw Interrupt Status	638
0x010	FCIM	RW	0x0000.0000	Flash Controller Interrupt Mask	641
0x014	FCMISC	RW1C	0x0000.0000	Flash Controller Masked Interrupt Status and Clear	643
0x020	FMC2	RW	0x0000.0000	Flash Memory Control 2	646
0x030	FWBVAL	RW	0x0000.0000	Flash Write Buffer Valid	647
0x03C	FLPEKEY	RO	0x0000.FFFF	Flash Program/Erase Key	648
0x100 - 0x17C	FWBn	RW	0x0000.0000	Flash Write Buffer n	649
0xFC0	FLASHPP	RO	0xF014.01FF	Flash Peripheral Properties	650
0xFC4	SSIZE	RO	0x0000.03FF	SRAM Size	652
0xFC8	FLASHCONF	RW	0x0000.0000	Flash Configuration Register	653
0xFCC	ROMSWMAP	RO	0x0000.0000	ROM Third-Party Software	655
0xFD0	FLASHDMASZ	RW	0x0000.0000	Flash DMA Address Size	657
0xFD4	FLASHDMAST	RW	0x0000.0000	Flash DMA Starting Address	658
EEPROM Registers (EEPROM Control Offset)					
0x000	EESIZE	RO	0x0060.0600	EEPROM Size Information	659
0x004	EEBLOCK	RW	0x0000.0000	EEPROM Current Block	660
0x008	EEOFFSET	RW	0x0000.0000	EEPROM Current Offset	661
0x010	EERDWR	RW	-	EEPROM Read-Write	662
0x014	EERDWRINC	RW	-	EEPROM Read-Write with Increment	663
0x018	EEDONE	RO	0x0000.0000	EEPROM Done Status	664
0x01C	EESUPP	RW	-	EEPROM Support Control and Status	666
0x020	EEUNLOCK	RW	-	EEPROM Unlock	667
0x030	EEPROT	RW	0x0000.0000	EEPROM Protection	668
0x034	EEPASS0	RW	-	EEPROM Password	670
0x038	EEPASS1	RW	-	EEPROM Password	670
0x03C	EEPASS2	RW	-	EEPROM Password	670
0x040	EEINT	RW	0x0000.0000	EEPROM Interrupt	671

Table 8-6. Flash Register Map (continued)

Offset	Name	Type	Reset	Description	See page
0x050	EEHIDE0	RW	0x0000.0000	EEPROM Block Hide 0	672
0x054	EEHIDE1	RW	0x0000.0000	EEPROM Block Hide 1	673
0x058	EEHIDE2	RW	0x0000.0000	EEPROM Block Hide 2	673
0x080	EEDBGME	RW	0x0000.0000	EEPROM Debug Mass Erase	674
0xFC0	EEPROMPP	RO	0x0000.01FF	EEPROM Peripheral Properties	675
Memory Registers (System Control Offset)					
0x0D4	RVP	RO	0x0101.FFF0	Reset Vector Pointer	676
0x1D0	BOOTCFG	RO	0xFFFF.FFFE	Boot Configuration	682
0x1E0	USER_REG0	W0	0xFFFF.FFFF	User Register 0	685
0x1E4	USER_REG1	W0	0xFFFF.FFFF	User Register 1	685
0x1E8	USER_REG2	W0	0xFFFF.FFFF	User Register 2	685
0x1EC	USER_REG3	W0	0xFFFF.FFFF	User Register 3	685
0x200	FMPRE0	RW	0xFFFF.FFFF	Flash Memory Protection Read Enable 0	677
0x204	FMPRE1	RW	0xFFFF.FFFF	Flash Memory Protection Read Enable 1	677
0x208	FMPRE2	RW	0xFFFF.FFFF	Flash Memory Protection Read Enable 2	677
0x20C	FMPRE3	RW	0xFFFF.FFFF	Flash Memory Protection Read Enable 3	677
0x210	FMPRE4	RW	0xFFFF.FFFF	Flash Memory Protection Read Enable 4	677
0x214	FMPRE5	RW	0xFFFF.FFFF	Flash Memory Protection Read Enable 5	677
0x218	FMPRE6	RW	0xFFFF.FFFF	Flash Memory Protection Read Enable 6	677
0x21C	FMPRE7	RW	0xFFFF.FFFF	Flash Memory Protection Read Enable 7	677
0x220	FMPRE8	RW	0xFFFF.FFFF	Flash Memory Protection Read Enable 8	677
0x224	FMPRE9	RW	0xFFFF.FFFF	Flash Memory Protection Read Enable 9	677
0x228	FMPRE10	RW	0xFFFF.FFFF	Flash Memory Protection Read Enable 10	677
0x22C	FMPRE11	RW	0xFFFF.FFFF	Flash Memory Protection Read Enable 11	677
0x230	FMPRE12	RW	0xFFFF.FFFF	Flash Memory Protection Read Enable 12	677
0x234	FMPRE13	RW	0xFFFF.FFFF	Flash Memory Protection Read Enable 13	677
0x238	FMPRE14	RW	0xFFFF.FFFF	Flash Memory Protection Read Enable 14	677
0x23C	FMPRE15	RW	0xFFFF.FFFF	Flash Memory Protection Read Enable 15	677
0x400	FMPPE0	RW	0xFFFF.FFFF	Flash Memory Protection Program Enable 0	679
0x404	FMPPE1	RW	0xFFFF.FFFF	Flash Memory Protection Program Enable 1	679
0x408	FMPPE2	RW	0xFFFF.FFFF	Flash Memory Protection Program Enable 2	679
0x40C	FMPPE3	RW	0xFFFF.FFFF	Flash Memory Protection Program Enable 3	679

Table 8-6. Flash Register Map (continued)

Offset	Name	Type	Reset	Description	See page
0x410	FMPPE4	RW	0xFFFF.FFFF	Flash Memory Protection Program Enable 4	679
0x414	FMPPE5	RW	0xFFFF.FFFF	Flash Memory Protection Program Enable 5	679
0x418	FMPPE6	RW	0xFFFF.FFFF	Flash Memory Protection Program Enable 6	679
0x41C	FMPPE7	RW	0xFFFF.FFFF	Flash Memory Protection Program Enable 7	679
0x420	FMPPE8	RW	0xFFFF.FFFF	Flash Memory Protection Program Enable 8	679
0x424	FMPPE9	RW	0xFFFF.FFFF	Flash Memory Protection Program Enable 9	679
0x428	FMPPE10	RW	0xFFFF.FFFF	Flash Memory Protection Program Enable 10	679
0x42C	FMPPE11	RW	0xFFFF.FFFF	Flash Memory Protection Program Enable 11	679
0x430	FMPPE12	RW	0xFFFF.FFFF	Flash Memory Protection Program Enable 12	679
0x434	FMPPE13	RW	0xFFFF.FFFF	Flash Memory Protection Program Enable 13	679
0x438	FMPPE14	RW	0xFFFF.FFFF	Flash Memory Protection Program Enable 14	679
0x43C	FMPPE15	RW	0xFFFF.FFFF	Flash Memory Protection Program Enable 15	679

8.4 Internal Memory Register Descriptions (Internal Memory Control Offset)

This section lists and describes the memory control registers, in numerical order by address offset. Registers in this section are relative to the memory control base address of 0x400F.D000.

Register 1: Flash Memory Address (FMA), offset 0x000

During a write operation, this register contains a 4-byte-aligned address and specifies where the data is written. During erase operations for flash space that is not user configurable (that is, **FMPREn**, **FMPPEn**, **USER_REGn**, **BOOTCFG**), this register contains a 16 KB-aligned CPU byte address and specifies which block is erased. Note that the alignment requirements must be met by software or the results of the operation are unpredictable.

Flash Memory Address (FMA)

Base 0x400F.D000

Offset 0x000

Type RW, reset 0x0000.0000

	31	30	29	28	27	26	25	24	23	22	21	20	19	18	17	16
	reserved												OFFSET			
Type	RO	RO	RO	RO	RO	RO	RO	RO	RO	RO	RO	RO	RW	RW	RW	RW
Reset	0	0	0	0	0	0	0	0	0	0	0	0	0	0	0	0
	15	14	13	12	11	10	9	8	7	6	5	4	3	2	1	0
	OFFSET															
Type	RW	RW	RW	RW	RW	RW	RW	RW	RW	RW	RW	RW	RW	RW	RW	RW
Reset	0	0	0	0	0	0	0	0	0	0	0	0	0	0	0	0

Bit/Field	Name	Type	Reset	Description
31:20	reserved	RO	0x0	Software should not rely on the value of a reserved bit. To provide compatibility with future products, the value of a reserved bit should be preserved across a read-modify-write operation.
19:0	OFFSET	RW	0x0	Address Offset Address offset in Flash memory where operation is performed, except for non-volatile registers (see "Non-Volatile Register Programming--Flash Memory Resident Registers" on page 621 for details on values for this field).

Register 2: Flash Memory Data (FMD), offset 0x004

This register contains the data to be written during the programming cycle. Note that the contents of this register are undefined for a read access of an execute-only block. This register is not used during erase cycles.

Flash Memory Data (FMD)

Base 0x400F.D000
 Offset 0x004
 Type RW, reset 0x0000.0000

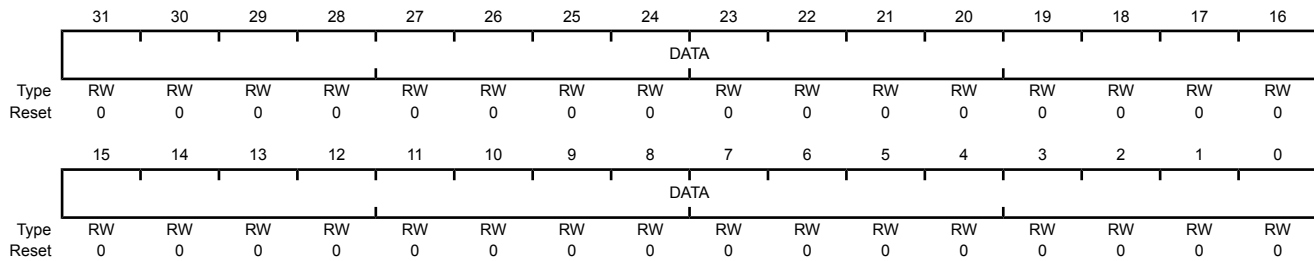

Bit/Field	Name	Type	Reset	Description
31:0	DATA	RW	0x0000.0000	Data Value Data value for write operation.

Register 3: Flash Memory Control (FMC), offset 0x008

When this register is written, the Flash memory controller initiates the appropriate access cycle for the location specified by the **Flash Memory Address (FMA)** register (see page 633). If the access is a write access, the data contained in the **Flash Memory Data (FMD)** register (see page 634) is written to the specified address.

For non-volatile registers, **FMPREn**, **FMPPEn**, **USER_REGn**, and **USER_REGn**, the respective register is programmed with the value to be written rather than the **FMD** register.

This register must be the final register written and initiates the memory operation. The four control bits in the lower byte of this register are used to initiate memory operations.

Care must be taken not to set multiple control bits as the results of such an operation are unpredictable.

Flash Memory Control (FMC)

Base 0x400F.D000

Offset 0x008

Type RW, reset 0x0000.0000

	31	30	29	28	27	26	25	24	23	22	21	20	19	18	17	16	
	WRKEY																
Type	WO	WO	WO	WO	WO	WO	WO	WO	WO	WO	WO	WO	WO	WO	WO	WO	
Reset	0	0	0	0	0	0	0	0	0	0	0	0	0	0	0	0	
	15	14	13	12	11	10	9	8	7	6	5	4	3	2	1	0	
	reserved												COMT	MERASE	ERASE	WRITE	
Type	RO	RO	RO	RO	RO	RO	RO	RO	RO	RO	RO	RO	RO	RW	RW	RW	RW
Reset	0	0	0	0	0	0	0	0	0	0	0	0	0	0	0	0	0

Bit/Field	Name	Type	Reset	Description
31:16	WRKEY	WO	0x0000	Flash Memory Write Key This field contains a write key, which is used to minimize the incidence of accidental Flash memory writes. The value 0xA442 or the <code>PEKEY</code> value in the <code>FLPEKEY</code> register must be written into this field for a Flash memory write to occur. The use of 0xA442 or <code>PEKEY</code> is dependent on the value of the <code>KEY</code> bit in the <code>BOOTCFG</code> register at 0x1D0. Writes to the <code>FMC</code> register without this <code>WRKEY</code> value are ignored. A read of this field returns the value 0.
15:4	reserved	RO	0x00	Software should not rely on the value of a reserved bit. To provide compatibility with future products, the value of a reserved bit should be preserved across a read-modify-write operation.

Bit/Field	Name	Type	Reset	Description
3	COMT	RW	0	<p>Commit Register Value</p> <p>This bit is used to commit writes to Flash-memory-resident registers and to monitor the progress of that process.</p> <p>Value Description</p> <p>0 A write of 0 has no effect on the state of this bit. When read, a 0 indicates that the previous commit access is complete.</p> <p>1 Set this bit to commit (write) the register value to a Flash-memory-resident register. When read, a 1 indicates that the previous commit access is not complete.</p> <p>See “Non-Volatile Register Programming-- Flash Memory Resident Registers” on page 621 for more information on programming Flash-memory-resident registers.</p>
2	MERASE	RW	0	<p>Mass Erase Flash Memory</p> <p>This bit is used to mass erase the Flash main memory and to monitor the progress of that process.</p> <p>Value Description</p> <p>0 A write of 0 has no effect on the state of this bit. When read, a 0 indicates that the previous mass erase access is complete.</p> <p>1 Set this bit to erase the Flash main memory. When read, a 1 indicates that the previous mass erase access is not complete.</p> <p>For information on erase time, see “Flash Memory” on page 1971.</p>
1	ERASE	RW	0	<p>Erase a Page of Flash Memory</p> <p>This bit is used to erase a page of Flash memory and to monitor the progress of that process.</p> <p>Value Description</p> <p>0 A write of 0 has no effect on the state of this bit. When read, a 0 indicates that the previous page erase access is complete.</p> <p>1 Set this bit to erase the Flash memory page specified by the contents of the FMA register. When read, a 1 indicates that the previous page erase access is not complete.</p> <p>For information on erase time, see “Flash Memory” on page 1971.</p>

Bit/Field	Name	Type	Reset	Description
0	WRITE	RW	0	<p>Write a Word into Flash Memory</p> <p>This bit is used to write a word into Flash memory and to monitor the progress of that process.</p> <p>Value Description</p> <p>0 A write of 0 has no effect on the state of this bit. When read, a 0 indicates that the previous write update access is complete.</p> <p>1 Set this bit to write the data stored in the FMD register into the Flash memory location specified by the contents of the FMA register. When read, a 1 indicates that the write update access is not complete.</p>

For information on programming time, see "Flash Memory" on page 1971.

Register 4: Flash Controller Raw Interrupt Status (FCRIS), offset 0x00C

This register indicates that the Flash memory controller has an interrupt condition. An interrupt is sent to the interrupt controller only if the corresponding **FCIM** register bit is set.

Flash Controller Raw Interrupt Status (FCRIS)

Base 0x400F.D000

Offset 0x00C

Type RO, reset 0x0000.0000

	31	30	29	28	27	26	25	24	23	22	21	20	19	18	17	16
	reserved															
Type	RO	RO	RO	RO	RO	RO	RO	RO	RO	RO	RO	RO	RO	RO	RO	RO
Reset	0	0	0	0	0	0	0	0	0	0	0	0	0	0	0	0
	15	14	13	12	11	10	9	8	7	6	5	4	3	2	1	0
	reserved		PROGRIS	reserved	ERRIS	INVDRIS	VOLTRIS	reserved						ERIS	PRIS	ARIS
Type	RO	RO	RO	RO	RO	RO	RO	RO	RO	RO	RO	RO	RO	RO	RO	RO
Reset	0	0	0	0	0	0	0	0	0	0	0	0	0	0	0	0

Bit/Field	Name	Type	Reset	Description
31:14	reserved	RO	0x0000.000	Software should not rely on the value of a reserved bit. To provide compatibility with future products, the value of a reserved bit should be preserved across a read-modify-write operation.
13	PROGRIS	RO	0	Program Verify Error Raw Interrupt Status Value Description 0 An interrupt has not occurred. 1 An interrupt is pending because the verify of a PROGRAM operation failed. If this error occurs when using the Flash write buffer, software must inspect the affected words to determine where the error occurred. This bit is cleared by writing a 1 to the PROGMISC bit in the FCMISC register.
12	reserved	RO	0	Software should not rely on the value of a reserved bit. To provide compatibility with future products, the value of a reserved bit should be preserved across a read-modify-write operation.
11	ERRIS	RO	0	Erase Verify Error Raw Interrupt Status Value Description 0 An interrupt has not occurred. 1 An interrupt is pending because the verify of an ERASE operation failed. If this error occurs when using the Flash write buffer, software must inspect the affected words to determine where the error occurred. This bit is cleared by writing a 1 to the ERMISC bit in the FCMISC register.

Bit/Field	Name	Type	Reset	Description
10	INVDRIS	RO	0	<p>Invalid Data Raw Interrupt Status</p> <p>Value Description</p> <p>0 An interrupt has not occurred.</p> <p>1 An interrupt is pending because a bit that was previously programmed as a 0 is now being requested to be programmed as a 1.</p> <p>This bit is cleared by writing a 1 to the <code>INVMISC</code> bit in the FCMISC register.</p>
9	VOLTRIS	RO	0	<p>Pump Voltage Raw Interrupt Status</p> <p>Value Description</p> <p>0 An interrupt has not occurred.</p> <p>1 An interrupt is pending because the regulated voltage of the pump went out of spec during the Flash operation and the operation was terminated.</p> <p>This bit is cleared by writing a 1 to the <code>VOLTMISC</code> bit in the FCMISC register.</p>
8:3	reserved	RO	0	Software should not rely on the value of a reserved bit. To provide compatibility with future products, the value of a reserved bit should be preserved across a read-modify-write operation.
2	ERIS	RO	0	<p>EEPROM Raw Interrupt Status</p> <p>This bit provides status EEPROM operation.</p> <p>Value Description</p> <p>0 An EEPROM interrupt has not occurred.</p> <p>1 An EEPROM interrupt has occurred.</p> <p>This bit is cleared by writing a 1 to the <code>EMISC</code> bit in the FCMISC register.</p>
1	PRIS	RO	0	<p>Programming Raw Interrupt Status</p> <p>This bit provides status on programming cycles which are write or erase actions generated through the FMC or FMC2 register bits (see page 635 and page 646).</p> <p>Value Description</p> <p>0 The programming or erase cycle has not completed.</p> <p>1 The programming or erase cycle has completed.</p> <p>This status is sent to the interrupt controller when the <code>PMASK</code> bit in the FCIM register is set.</p> <p>This bit is cleared by writing a 1 to the <code>PMISC</code> bit in the FCMISC register.</p>

Bit/Field	Name	Type	Reset	Description
0	ARIS	RO	0	Access Raw Interrupt Status Value Description 0 No access has tried to improperly program or erase the Flash memory. 1 A program or erase action was attempted on a block of Flash memory that contradicts the protection policy for that block as set in the FMPPEn registers. This status is sent to the interrupt controller when the AMASK bit in the FCIM register is set. This bit is cleared by writing a 1 to the AMISC bit in the FCMISC register.

Register 5: Flash Controller Interrupt Mask (FCIM), offset 0x010

This register controls whether the Flash memory controller generates interrupts to the controller.

Flash Controller Interrupt Mask (FCIM)

Base 0x400F.D000

Offset 0x010

Type RW, reset 0x0000.0000

	31	30	29	28	27	26	25	24	23	22	21	20	19	18	17	16
	reserved															
Type	RO	RO	RO	RO	RO	RO	RO	RO	RO	RO	RO	RO	RO	RO	RO	RO
Reset	0	0	0	0	0	0	0	0	0	0	0	0	0	0	0	0
	15	14	13	12	11	10	9	8	7	6	5	4	3	2	1	0
	reserved		PROGMASK	reserved	ERMASK	INVDMASK	VOLTMASK	reserved						EMASK	PMASK	AMASK
Type	RO	RO	RW	RO	RW	RW	RW	RO	RO	RO	RO	RO	RO	RW	RW	RW
Reset	0	0	0	0	0	0	0	0	0	0	0	0	0	0	0	0

Bit/Field	Name	Type	Reset	Description
31:14	reserved	RO	0x0000.000	Software should not rely on the value of a reserved bit. To provide compatibility with future products, the value of a reserved bit should be preserved across a read-modify-write operation.
13	PROGMASK	RW	0	Program Verify Error Interrupt Mask Value Description 0 The <code>PROGRIS</code> interrupt is suppressed and not sent to the interrupt controller. 1 An interrupt is sent to the interrupt controller when the <code>PROGRIS</code> bit is set.
12	reserved	RO	0	Software should not rely on the value of a reserved bit. To provide compatibility with future products, the value of a reserved bit should be preserved across a read-modify-write operation.
11	ERMASK	RW	0	Erase Verify Error Interrupt Mask Value Description 0 The <code>ERRIS</code> interrupt is suppressed and not sent to the interrupt controller. 1 An interrupt is sent to the interrupt controller when the <code>ERRIS</code> bit is set.
10	INVDMASK	RW	0	Invalid Data Interrupt Mask Value Description 0 The <code>INVDRIS</code> interrupt is suppressed and not sent to the interrupt controller. 1 An interrupt is sent to the interrupt controller when the <code>INVDRIS</code> bit is set.

Bit/Field	Name	Type	Reset	Description
9	VOLTMASK	RW	0	<p>Pump Voltage Interrupt Mask</p> <p>Value Description</p> <p>0 The <code>VOLTRIS</code> interrupt is suppressed and not sent to the interrupt controller.</p> <p>1 An interrupt is sent to the interrupt controller when the <code>VOLTRIS</code> bit is set.</p>
8:3	reserved	RO	0	<p>Software should not rely on the value of a reserved bit. To provide compatibility with future products, the value of a reserved bit should be preserved across a read-modify-write operation.</p>
2	EMASK	RW	0	<p>EEPROM Interrupt Mask</p> <p>Value Description</p> <p>0 The <code>ERIS</code> interrupt is suppressed and not sent to the interrupt controller.</p> <p>1 An interrupt is sent to the interrupt controller when the <code>ERIS</code> bit is set.</p>
1	PMASK	RW	0	<p>Programming Interrupt Mask</p> <p>This bit controls the reporting of the programming raw interrupt status to the interrupt controller.</p> <p>Value Description</p> <p>0 The <code>PRIS</code> interrupt is suppressed and not sent to the interrupt controller.</p> <p>1 An interrupt is sent to the interrupt controller when the <code>PRIS</code> bit is set.</p>
0	AMASK	RW	0	<p>Access Interrupt Mask</p> <p>This bit controls the reporting of the access raw interrupt status to the interrupt controller.</p> <p>Value Description</p> <p>0 The <code>ARIS</code> interrupt is suppressed and not sent to the interrupt controller.</p> <p>1 An interrupt is sent to the interrupt controller when the <code>ARIS</code> bit is set.</p>

Register 6: Flash Controller Masked Interrupt Status and Clear (FCMISC), offset 0x014

This register provides two functions. First, it reports the cause of an interrupt by indicating which interrupt source or sources are signalling the interrupt. Second, it serves as the method to clear the interrupt reporting.

Flash Controller Masked Interrupt Status and Clear (FCMISC)

Base 0x400F.D000

Offset 0x014

Type RW1C, reset 0x0000.0000

	31	30	29	28	27	26	25	24	23	22	21	20	19	18	17	16
	reserved															
Type	RO	RO	RO	RO	RO	RO	RO	RO	RO	RO	RO	RO	RO	RO	RO	RO
Reset	0	0	0	0	0	0	0	0	0	0	0	0	0	0	0	0
	15	14	13	12	11	10	9	8	7	6	5	4	3	2	1	0
	reserved		PROGMISC	reserved	ERMISC	INVMISC	VOLTMISC	reserved						EMISC	PMISC	AMISC
Type	RO	RO	RW1C	RO	RW1C	RW1C	RW1C	RO	RO	RO	RO	RO	RO	RW1C	RW1C	RW1C
Reset	0	0	0	0	0	0	0	0	0	0	0	0	0	0	0	0

Bit/Field	Name	Type	Reset	Description
31:14	reserved	RO	0x0000.000	Software should not rely on the value of a reserved bit. To provide compatibility with future products, the value of a reserved bit should be preserved across a read-modify-write operation.
13	PROGMISC	RW1C	0	<p>PROGVER Masked Interrupt Status and Clear</p> <p>Value Description</p> <p>0 When read, a 0 indicates that an interrupt has not occurred. A write of 0 has no effect on the state of this bit.</p> <p>1 When read, a 1 indicates that an unmasked interrupt was signaled. Writing a 1 to this bit clears PROGMISC and also the PROGRIS bit in the FCRIS register (see page 638).</p>
12	reserved	RO	0	Software should not rely on the value of a reserved bit. To provide compatibility with future products, the value of a reserved bit should be preserved across a read-modify-write operation.
11	ERMISC	RW1C	0	<p>ERVER Masked Interrupt Status and Clear</p> <p>Value Description</p> <p>0 When read, a 0 indicates that an interrupt has not occurred. A write of 0 has no effect on the state of this bit.</p> <p>1 When read, a 1 indicates that an unmasked interrupt was signaled. Writing a 1 to this bit clears ERMISC and also the ERRIS bit in the FCRIS register (see page 638).</p>

Bit/Field	Name	Type	Reset	Description
10	INVDMISC	RW1C	0	<p>Invalid Data Masked Interrupt Status and Clear</p> <p>Value Description</p> <p>0 When read, a 0 indicates that an interrupt has not occurred. A write of 0 has no effect on the state of this bit.</p> <p>1 When read, a 1 indicates that an unmasked interrupt was signaled. Writing a 1 to this bit clears <code>INVDMISC</code> and also the <code>INVDNIS</code> bit in the FCRIS register (see page 638).</p>
9	VOLTMISC	RW1C	0	<p>VOLT Masked Interrupt Status and Clear</p> <p>Value Description</p> <p>0 When read, a 0 indicates that an interrupt has not occurred. A write of 0 has no effect on the state of this bit.</p> <p>1 When read, a 1 indicates that an unmasked interrupt was signaled. Writing a 1 to this bit clears <code>VOLTMISC</code> and also the <code>VOLTRIS</code> bit in the FCRIS register (see page 638).</p>
8:3	reserved	RO	0	<p>Software should not rely on the value of a reserved bit. To provide compatibility with future products, the value of a reserved bit should be preserved across a read-modify-write operation.</p>
2	EMISC	RW1C	0	<p>EEPROM Masked Interrupt Status and Clear</p> <p>Value Description</p> <p>0 When read, a 0 indicates that an interrupt has not occurred. A write of 0 has no effect on the state of this bit.</p> <p>1 When read, a 1 indicates that an unmasked interrupt was signaled. Writing a 1 to this bit clears <code>EMISC</code> and also the <code>ERIS</code> bit in the FCRIS register (see page 638).</p>
1	PMISC	RW1C	0	<p>Programming Masked Interrupt Status and Clear</p> <p>Value Description</p> <p>0 When read, a 0 indicates that a programming cycle complete interrupt has not occurred. A write of 0 has no effect on the state of this bit.</p> <p>1 When read, a 1 indicates that an unmasked interrupt was signaled because a programming cycle completed. Writing a 1 to this bit clears <code>PMISC</code> and also the <code>PRIS</code> bit in the FCRIS register (see page 638).</p>

Bit/Field	Name	Type	Reset	Description
0	AMISC	RW1C	0	Access Masked Interrupt Status and Clear
				Value Description
			0	When read, a 0 indicates that no improper accesses have occurred. A write of 0 has no effect on the state of this bit.
			1	When read, a 1 indicates that an unmasked interrupt was signaled because a program or erase action was attempted on a block of Flash memory that contradicts the protection policy for that block as set in the FMPPEn registers. Writing a 1 to this bit clears AMISC and also the ARIS bit in the FCRIS register (see page 638).

Register 7: Flash Memory Control 2 (FMC2), offset 0x020

When this register is written, the Flash memory controller initiates the appropriate access cycle for the location specified by the **Flash Memory Address (FMA)** register (see page 633). If the access is a write access, the data contained in the **Flash Write Buffer (FWB)** registers is written.

This register must be the final register written as it initiates the memory operation.

Flash Memory Control 2 (FMC2)

Base 0x400F.D000
Offset 0x020
Type RW, reset 0x0000.0000

	31	30	29	28	27	26	25	24	23	22	21	20	19	18	17	16
	WRKEY															
Type	WO	WO	WO	WO	WO	WO	WO	WO	WO	WO	WO	WO	WO	WO	WO	WO
Reset	0	0	0	0	0	0	0	0	0	0	0	0	0	0	0	0
	15	14	13	12	11	10	9	8	7	6	5	4	3	2	1	0
	reserved															WRBUF
Type	RO	RO	RO	RO	RO	RO	RO	RO	RO	RO	RO	RO	RO	RO	RO	RW
Reset	0	0	0	0	0	0	0	0	0	0	0	0	0	0	0	0

Bit/Field	Name	Type	Reset	Description
31:16	WRKEY	WO	0x0000	<p>Flash Memory Write Key</p> <p>This field contains a write key, which is used to minimize the incidence of accidental Flash memory writes. There are two options for the WRKEY value:</p> <p>If the KEY value in the BOOTCFG register is 0x1 at reset, the value 0xA442 is used as a key enable to initiate the appropriate access cycle for the location specified by the address in the FMA register.</p> <p>If the KEY value in the BOOTCFG register is 0x0 at reset, the value programmed in the FLPEKEY register is used as a key enable to initiate the appropriate access cycle for the location specified by the address in the FMA register.</p> <p>Writes to the FMC2 register without this WRKEY value are ignored. A read of this field returns the value 0.</p>
15:1	reserved	RO	0x000	Software should not rely on the value of a reserved bit. To provide compatibility with future products, the value of a reserved bit should be preserved across a read-modify-write operation.
0	WRBUF	RW	0	<p>Buffered Flash Memory Write</p> <p>This bit is used to start a buffered write to Flash memory.</p> <p>Value Description</p> <p>0 A write of 0 has no effect on the state of this bit. When read, a 0 indicates that the previous buffered Flash memory write access is complete.</p> <p>1 Set this bit to write the data stored in the FWBn registers to the location specified by the contents of the FMA register. When read, a 1 indicates that the previous buffered Flash memory write access is not complete.</p>

For information on programming time, see "Flash Memory" on page 1971.

Register 8: Flash Write Buffer Valid (FWBVAL), offset 0x030

This register provides a bitwise status of which **FWB_n** registers have been written by the processor since the last write of the Flash memory write buffer. The entries with a 1 are written on the next write of the Flash memory write buffer. This register is cleared after the write operation by hardware. A protection violation on the write operation also clears this status.

Software can program the same 32 words to various Flash memory locations by setting the **FWB_[n]** bits after they are cleared by the write operation. The next write operation then uses the same data as the previous one. In addition, if a **FWB_n** register change should not be written to Flash memory, software can clear the corresponding **FWB_[n]** bit to preserve the existing data when the next write operation occurs.

Flash Write Buffer Valid (FWBVAL)

Base 0x400F.D000
Offset 0x030
Type RW, reset 0x0000.0000

	31	30	29	28	27	26	25	24	23	22	21	20	19	18	17	16
	FWB[n]															
Type	RW	RW	RW	RW	RW	RW	RW	RW	RW	RW	RW	RW	RW	RW	RW	RW
Reset	0	0	0	0	0	0	0	0	0	0	0	0	0	0	0	0
	15	14	13	12	11	10	9	8	7	6	5	4	3	2	1	0
	FWB[n]															
Type	RW	RW	RW	RW	RW	RW	RW	RW	RW	RW	RW	RW	RW	RW	RW	RW
Reset	0	0	0	0	0	0	0	0	0	0	0	0	0	0	0	0

Bit/Field	Name	Type	Reset	Description
31:0	FWB[n]	RW	0x0	Flash Memory Write Buffer

Value Description

Value	Description
0	The corresponding FWB_n register has no new data to be written.
1	The corresponding FWB_n register has been updated since the last buffer write operation and is ready to be written to Flash memory.

Bit 0 corresponds to **FWB0**, offset 0x100, and bit 31 corresponds to **FWB31**, offset 0x13C.

Register 9: Flash Program/Erase Key (FLPEKEY), offset 0x03C

This register provides a mechanism for protection from inadvertent writes to flash by supplying a 16-bit key. If the `KEY` value in the `BOOTCFG` register is 0, then this value is used as the 16-bit key in place of 0xA442 in the `FMC/FMC2` registers for committed flash writes.

This can be used for cases where a new image is downloaded and the first word of the new image has the 16-bit key value to be used for that product. This 16-bit key is used to allow the write to `FMC` or `FMC2` to take place.

Flash Program/Erase Key (FLPEKEY)

Base 0x400F.D000

Offset 0x03C

Type RO, reset 0x0000.FFFF

	31	30	29	28	27	26	25	24	23	22	21	20	19	18	17	16
	reserved															
Type	RO	RO	RO	RO	RO	RO	RO	RO	RO	RO	RO	RO	RO	RO	RO	RO
Reset	0	0	0	0	0	0	0	0	0	0	0	0	0	0	0	0
	15	14	13	12	11	10	9	8	7	6	5	4	3	2	1	0
	PEKEY															
Type	RO	RO	RO	RO	RO	RO	RO	RO	RO	RO	RO	RO	RO	RO	RO	RO
Reset	1	1	1	1	1	1	1	1	1	1	1	1	1	1	1	1

Bit/Field	Name	Type	Reset	Description
31:16	reserved	RO	0x0000	Software should not rely on the value of a reserved bit. To provide compatibility with future products, the value of a reserved bit should be preserved across a read-modify-write operation.
15:0	PEKEY	RO	0xFFFF	Key Value When a value other than all 1s or all 0s, this 16-bit value is used as the "match" for the upper 16-bits of the register <code>FMC</code> and <code>FMC2</code> keys.

Register 10: Flash Write Buffer n (FWBn), offset 0x100 - 0x17C

These 32 registers hold the contents of the data to be written into the Flash memory on a buffered Flash memory write operation. The offset selects one of the 32-bit registers. Only **FWBn** registers that have been updated since the preceding buffered Flash memory write operation are written into the Flash memory, so it is not necessary to write the entire bank of registers in order to write 1 or 2 words. The **FWBn** registers are written into the Flash memory with the **FWB0** register corresponding to the address contained in **FMA**. **FWB1** is written to the address **FMA+0x4** etc. Note that only data bits that are 0 result in the Flash memory being modified. A data bit that is 1 leaves the content of the Flash memory bit at its previous value.

Flash Write Buffer n (FWBn)

Base 0x400F.D000
Offset 0x100 - 0x17C
Type RW, reset 0x0000.0000

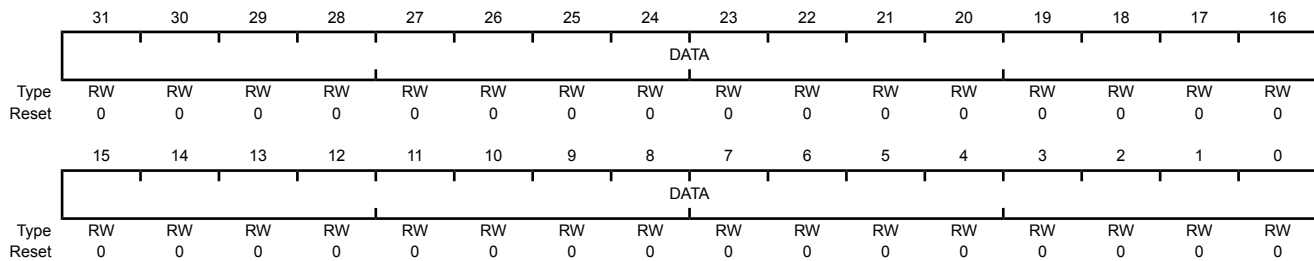

Bit/Field	Name	Type	Reset	Description
31:0	DATA	RW	0x0000.0000	Data Data to be written into the Flash memory.

Register 11: Flash Peripheral Properties (FLASHPP), offset 0xFC0

Flash Peripheral Properties (FLASHPP)

Base 0x400F.D000
 Offset 0xFC0
 Type RO, reset 0xF014.01FF

	31	30	29	28	27	26	25	24	23	22	21	20	19	18	17	16
	reserved	PFC	FMM	DFA	reserved				EESS				MAINSS			
Type	RO	RO	RO	RO	RO	RO	RO	RO	RO	RO	RO	RO	RO	RO	RO	RO
Reset	0	1	1	1	0	0	0	0	0	0	0	1	0	1	0	0
	15	14	13	12	11	10	9	8	7	6	5	4	3	2	1	0
	SIZE															
Type	RO	RO	RO	RO	RO	RO	RO	RO	RO	RO	RO	RO	RO	RO	RO	RO
Reset	0	0	0	0	0	0	0	1	1	1	1	1	1	1	1	1

Bit/Field	Name	Type	Reset	Description
31	reserved	RO	0	Software should not rely on the value of a reserved bit. To provide compatibility with future products, the value of a reserved bit should be preserved across a read-modify-write operation.
30	PFC	RO	0x1	Prefetch Buffer Mode Value Description 0 Single set of 2x256-bit buffers used. 1 Two sets of 2x256-bit prefetch buffers are available to use and may be enabled through the FLASHCONF register.
29	FMM	RO	0x1	Flash Mirror Mode Value Description 0 Mirror Mode not available. 1 Flash Mirror Mode is available to be enabled or disabled by user through FLASHCONF register.
28	DFA	RO	0x1	DMA Flash Access Note: μ DMA can only access flash in Run Mode (not available in low power modes). Value Description 0 DMA cannot be used to access Flash 1 DMA may access the Flash memory range specified by the FLASHDMASZ and FLASHDMASZ registers
27:23	reserved	RO	0	Software should not rely on the value of a reserved bit. To provide compatibility with future products, the value of a reserved bit should be preserved across a read-modify-write operation.

Bit/Field	Name	Type	Reset	Description
22:19	EESS	RO	0x2	EEPROM Sector Size of the physical bank Value Description 0x0 1 KB 0x1 2 KB 0x2 4 KB 0x3 8 KB 0x4-0x7 reserved
18:16	MAINSS	RO	0x4	Flash Sector Size of the physical bank Value Description 0x0 1 KB 0x1 2 KB 0x2 4 KB 0x3 8 KB 0x4 16 KB 0x5-0x7 reserved
15:0	SIZE	RO	0x1FF	Flash Size Indicates the size of the on-chip Flash memory Value Description 0x01FF 1024 KB of Flash

Register 12: SRAM Size (SSIZE), offset 0xFC4

This register indicates the size of the on-chip SRAM.

Important: This register should be used to determine the size of the SRAM that is implemented on this microcontroller.

SRAM Size (SSIZE)

Base 0x400F.D000
 Offset 0xFC4
 Type RO, reset 0x0000.03FF

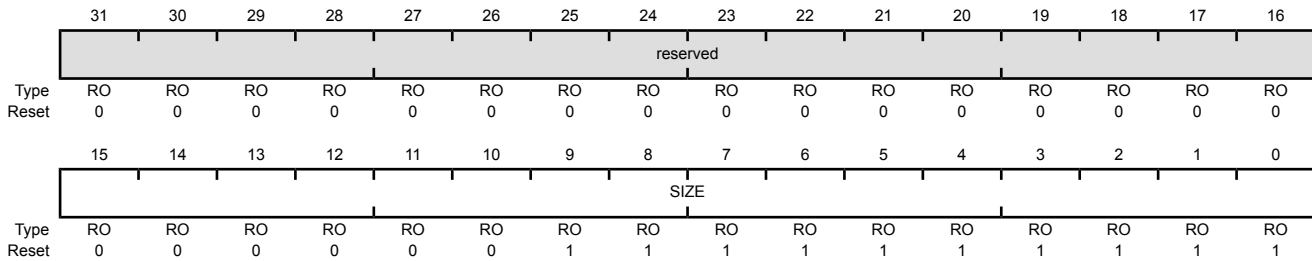

Bit/Field	Name	Type	Reset	Description
31:16	reserved	RO	0x0	Software should not rely on the value of a reserved bit. To provide compatibility with future products, the value of a reserved bit should be preserved across a read-modify-write operation.
15:0	SIZE	RO	0x3FF	SRAM Size Indicates the size of the on-chip SRAM.
				Value Description
				0x03FF 256 KB of SRAM

Register 13: Flash Configuration Register (FLASHCONF), offset 0xFC8

The **FLASHCONF** register allows the user to enable or disable various properties of the Flash. The force bits, **FBFON** and **FBFOFF**, can be used to test code performance and execution by turning the prefetch buffers on and subsequently forcing them off.

Flash Configuration Register (FLASHCONF)

Base 0x400F.D000

Offset 0xFC8

Type RW, reset 0x0000.0000

	31	30	29	28	27	26	25	24	23	22	21	20	19	18	17	16
	reserved	FMME	SPFE	reserved								CLRTV	reserved		FPFON	FPFOFF
Type	RO	RW	RW	RO	RO	RO	RO	RO	RO	RO	RO	RW	RO	RO	RW	RW
Reset	0	0	0	0	0	0	0	0	0	0	0	0	0	0	0	0
	15	14	13	12	11	10	9	8	7	6	5	4	3	2	1	0
	reserved															
Type	RO	RO	RO	RO	RO	RO	RO	RO	RO	RO	RO	RO	RO	RO	RO	RO
Reset	0	0	0	0	0	0	0	0	0	0	0	0	0	0	0	0

Bit/Field	Name	Type	Reset	Description
31	reserved	RO	0	Software should not rely on the value of a reserved bit. To provide compatibility with future products, the value of a reserved bit should be preserved across a read-modify-write operation.
30	FMME	RW	0x0	Flash Mirror Mode Enable Value Description 0 Flash mirror mode is disabled. 1 Flash mirror mode feature is enabled. Access to the lower banks is translated to upper.
29	SPFE	RW	0x0	Single Prefetch Mode Enable Value Description 0 A 4x256-bit prefetch buffer is enabled and used. 1 A single 2x256-bit prefetch buffer is enabled and used.
28:21	reserved	RO	0x000	Software should not rely on the value of a reserved bit. To provide compatibility with future products, the value of a reserved bit should be preserved across a read-modify-write operation.
20	CLRTV	RW	0	Clear Valid Tags This is a self-clearing bit. Value Description 0 No effect. 1 Clear valid tags in the prefetch buffer.
19:18	reserved	RO	0	Software should not rely on the value of a reserved bit. To provide compatibility with future products, the value of a reserved bit should be preserved across a read-modify-write operation.

Bit/Field	Name	Type	Reset	Description
17	FPFON	RW	0	Force Prefetch On Value Description 0 No effect 1 Force prefetch buffers to be enabled.
16	FPFOFF	RW	0	Force Prefetch Off Value Description 0 No effect 1 Force prefetch buffers to be disabled.
15:0	reserved	RO	0x0000	Software should not rely on the value of a reserved bit. To provide compatibility with future products, the value of a reserved bit should be preserved across a read-modify-write operation.

Register 14: ROM Third-Party Software (ROMSWMAP), offset 0xFCC

This register indicates the presence of third-party software in the on-chip ROM. ROMSWMAP enables the ROM apertures that are available.

ROM Third-Party Software (ROMSWMAP)

Base 0x400F.D000

Offset 0xFCC

Type RO, reset 0x0000.0000

	31	30	29	28	27	26	25	24	23	22	21	20	19	18	17	16
	reserved															
Type	RO	RO	RO	RO	RO	RO	RO	RO	RO	RO	RO	RO	RO	RO	RO	RO
Reset	0	0	0	0	0	0	0	0	0	0	0	0	0	0	0	0
	15	14	13	12	11	10	9	8	7	6	5	4	3	2	1	0
	SW7EN		SW6EN		SW5EN		SW4EN		SW3EN		SW2EN		SW1EN		SW0EN	
Type	RO	RO	RO	RO	RO	RO	RO	RO	RO	RO	RO	RO	RO	RO	RO	RO
Reset	0	0	0	0	0	0	0	0	0	0	0	0	0	0	0	0

Bit/Field	Name	Type	Reset	Description
31:16	reserved	RO	0x0	Software should not rely on the value of a reserved bit. To provide compatibility with future products, the value of a reserved bit should be preserved across a read-modify-write operation.
15:14	SW7EN	RO	0x0	ROM SW Region 7 Availability Value Description 0x0 Software region not available to the core. 0x1 Region available to core 0x2-0x3 reserved
13:12	SW6EN	RO	0x0	ROM SW Region 6 Availability Value Description 0x0 Software region not available to the core. 0x1 Region available to core 0x2-0x3 reserved
11:10	SW5EN	RO	0x0	ROM SW Region 5 Availability Value Description 0x0 Software region not available to the core. 0x1 Region available to core 0x2-0x3 reserved
9:8	SW4EN	RO	0x0	ROM SW Region 4 Availability Value Description 0x0 Software region not available to the core. 0x1 Region available to core 0x2-0x3 reserved

Bit/Field	Name	Type	Reset	Description
7:6	SW3EN	RO	0x0	ROM SW Region 3 Availability Value Description 0x0 Software region not available to the core. 0x1 Region available to core 0x2-0x3 reserved
5:4	SW2EN	RO	0x0	ROM SW Region 2 Availability Value Description 0x0 Software region not available to the core. 0x1 Region available to core 0x2-0x3 reserved
3:2	SW1EN	RO	0x0	ROM SW Region 1 Availability Value Description 0x0 Software region not available to the core. 0x1 Region available to core 0x2-0x3 reserved
1:0	SW0EN	RO	0x0	ROM SW Region 0 Availability Value Description 0x0 Software region not available to the core. 0x1 Region available to core 0x2-0x3 reserved

Register 15: Flash DMA Address Size (FLASHDMASZ), offset 0xFD0

The **FLASHDMASZ** register contains the area of Flash that the μ DMA can access.

Note: The μ DMA can access Flash in Run Mode only (not available in low power modes).

Flash DMA Address Size (FLASHDMASZ)

Base 0x400F.D000

Offset 0xFD0

Type RW, reset 0x0000.0000

	31	30	29	28	27	26	25	24	23	22	21	20	19	18	17	16
	reserved														SIZE	
Type	RO	RO	RO	RO	RO	RO	RO	RO	RO	RO	RO	RO	RO	RO	RW	RW
Reset	0	0	0	0	0	0	0	0	0	0	0	0	0	0	0	0
	15	14	13	12	11	10	9	8	7	6	5	4	3	2	1	0
	SIZE															
Type	RW	RW	RW	RW	RW	RW	RW	RW	RW	RW	RW	RW	RW	RW	RW	RW
Reset	0	0	0	0	0	0	0	0	0	0	0	0	0	0	0	0

Bit/Field	Name	Type	Reset	Description
31:18	reserved	RO	0x0000	Software should not rely on the value of a reserved bit. To provide compatibility with future products, the value of a reserved bit should be preserved across a read-modify-write operation.
17:0	SIZE	RW	0x0	μ DMA-accessible Memory Size The size of the region addressable by the μ DMA. Note that the <i>DFA</i> bit must be set in the FLASHPP register before this value can be programmed. Size of region is defined as $2^{*(SIZE + 1)}$ KB.

Register 16: Flash DMA Starting Address (FLASHDMAST), offset 0xFD4

The starting address for the Flash region accessible by the μ DMA is programmed in the **FLASHDMAST** register.

Note: The μ DMA can access Flash in Run Mode only (not available in low power modes).

Flash DMA Starting Address (FLASHDMAST)

Base 0x400F.D000

Offset 0xFD4

Type RW, reset 0x0000.0000

	31	30	29	28	27	26	25	24	23	22	21	20	19	18	17	16
	reserved			ADDR												
Type	RO	RO	RO	RW	RW	RW	RW	RW	RW	RW	RW	RW	RW	RW	RW	RW
Reset	0	0	0	0	0	0	0	0	0	0	0	0	0	0	0	0
	15	14	13	12	11	10	9	8	7	6	5	4	3	2	1	0
	ADDR					reserved										
Type	RW	RW	RW	RW	RW	RO	RO	RO	RO	RO	RO	RO	RO	RO	RO	RO
Reset	0	0	0	0	0	0	0	0	0	0	0	0	0	0	0	0

Bit/Field	Name	Type	Reset	Description
31:29	reserved	RO	0x0	Software should not rely on the value of a reserved bit. To provide compatibility with future products, the value of a reserved bit should be preserved across a read-modify-write operation.
28:11	ADDR	RW	0x0	Contains the starting address of the flash region accessible by μ DMA if the FLASHPP register <i>DFA</i> bit is set
10:0	reserved	RO	0x0	Software should not rely on the value of a reserved bit. To provide compatibility with future products, the value of a reserved bit should be preserved across a read-modify-write operation.

8.5 EEPROM Register Descriptions (EEPROM Offset)

This section lists and describes the EEPROM registers, in numerical order by address offset. Registers in this section are relative to the EEPROM base address of 0x400A.F000.

Note that the EEPROM module clock must be enabled before the registers can be programmed (see page 407). There must be a delay of 3 system clocks after the EEPROM module clock is enabled before any EEPROM module registers are accessed. In addition, after enabling or resetting the EEPROM module, software must wait until the *WORKING* bit in the **EEDONE** register is clear before accessing any EEPROM registers.

Register 17: EEPROM Size Information (EESIZE), offset 0x000

The **EESIZE** register indicates the number of 16-word blocks and 32-bit words in the EEPROM.

EEPROM Size Information (EESIZE)

Base 0x400A.F000

Offset 0x000

Type RO, reset 0x0060.0600

	31	30	29	28	27	26	25	24	23	22	21	20	19	18	17	16	
	reserved					BLKCNT											
Type	RO	RO	RO	RO	RO	RO	RO	RO	RO	RO	RO	RO	RO	RO	RO	RO	RO
Reset	0	0	0	0	0	0	0	0	0	0	1	1	0	0	0	0	0
	15	14	13	12	11	10	9	8	7	6	5	4	3	2	1	0	
	WORDCNT																
Type	RO	RO	RO	RO	RO	RO	RO	RO	RO	RO	RO	RO	RO	RO	RO	RO	RO
Reset	0	0	0	0	0	1	1	0	0	0	0	0	0	0	0	0	0

Bit/Field	Name	Type	Reset	Description
31:27	reserved	RO	0	Software should not rely on the value of a reserved bit. To provide compatibility with future products, the value of a reserved bit should be preserved across a read-modify-write operation.
26:16	BLKCNT	RO	0x60	Number of 16-Word Blocks This value encoded in this field describes the number of 16-word blocks in the EEPROM.
15:0	WORDCNT	RO	0x600	Number of 32-Bit Words This value encoded in this field describes the number of 32-bit words in the EEPROM.

Register 18: EEPROM Current Block (EEBLOCK), offset 0x004

The **EEBLOCK** register is used to select the EEPROM block for subsequent reads, writes, and protection control. The value is a page offset into the EEPROM, such that the first block is 0, then second block is 1, etc. Each block contains 16 words. Attempts to set an invalid block causes the **BLOCK** field to be configured to 0. To verify that the intended block is being accessed, software can read the **BLOCK** field after it has been written. An invalid block can be either a non-existent block or a block that has been hidden using the **EEHIDE** register. Note that block 0 cannot be hidden.

EEPROM Current Block (EEBLOCK)

Base 0x400A.F000

Offset 0x004

Type RW, reset 0x0000.0000

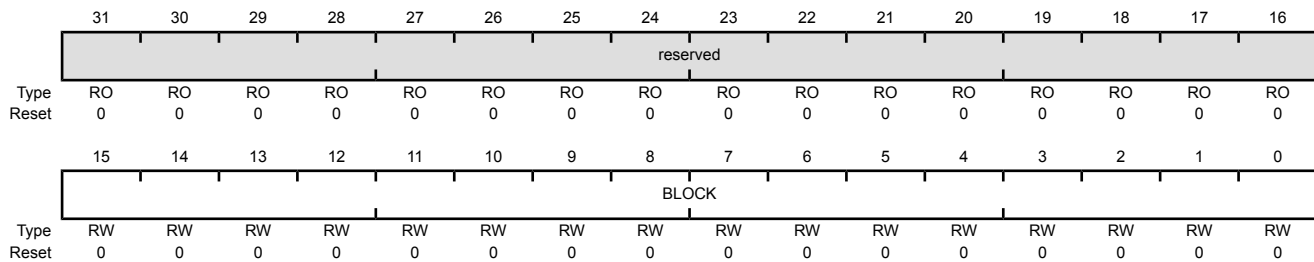

Bit/Field	Name	Type	Reset	Description
31:16	reserved	RO	0x00000	Software should not rely on the value of a reserved bit. To provide compatibility with future products, the value of a reserved bit should be preserved across a read-modify-write operation.
15:0	BLOCK	RW	0x0000	<p>Current Block</p> <p>This field specifies the block in the EEPROM that is selected for subsequent accesses. Once this field is configured, the read-write registers operate against the specified block, using the EEOFFSET register to select the word within the block. Additionally, the protection and unlock registers are used for the selected block. The maximum value that can be written into this register is determined by the block count, as indicated by the EESIZE register. Attempts to write this field larger than the maximum number of blocks or to a locked block causes this field to be configured to 0.</p>

Register 19: EEPROM Current Offset (EEOFFSET), offset 0x008

The **EEOFFSET** register is used to select the EEPROM word to read or write within the block selected by the **EEBLOCK** register. The value is a word offset into the block. Because accesses to the **EERDWRINC** register change the offset, software can read the contents of this register to determine the current offset.

EEPROM Current Offset (EEOFFSET)

Base 0x400A.F000

Offset 0x008

Type RW, reset 0x0000.0000

	31	30	29	28	27	26	25	24	23	22	21	20	19	18	17	16
	reserved															
Type	RO	RO	RO	RO	RO	RO	RO	RO	RO	RO	RO	RO	RO	RO	RO	RO
Reset	0	0	0	0	0	0	0	0	0	0	0	0	0	0	0	0
	15	14	13	12	11	10	9	8	7	6	5	4	3	2	1	0
	reserved												OFFSET			
Type	RO	RO	RO	RO	RO	RO	RO	RO	RO	RO	RO	RO	RW	RW	RW	RW
Reset	0	0	0	0	0	0	0	0	0	0	0	0	0	0	0	0

Bit/Field	Name	Type	Reset	Description
31:4	reserved	RO	0x0000.000	Software should not rely on the value of a reserved bit. To provide compatibility with future products, the value of a reserved bit should be preserved across a read-modify-write operation.
3:0	OFFSET	RW	0x0	Current Address Offset This value is the current address specified as an offset into the block selected by the EEBLOCK register. Once configured, the read-write registers, EERDRWR and EERDWRINC , operate against that address. The offset is automatically incremented by the EERDWRINC register, with wrap around within the block, which means the offset is incremented from 15 back to 0.

Register 20: EEPROM Read-Write (EERDWR), offset 0x010

The **EERDWR** register is used to read or write the EEPROM word at the address pointed to by the **EEBLOCK** and **EEOFFSET** registers. If the protection or access rules do not permit access, the operation is handled as follows: if reading is not allowed, the value 0xFFFF.FFFF is returned in all cases; if writing is not allowed, the **EEDONE** register is configured to indicate an error.

Note: A read of the **EERDWR** register during the EEPROM initialization sequence is only valid when the **WORKING** bit is 0 in **EEDONE** register:

EEPROM Read-Write (EERDWR)

Base 0x400A.F000

Offset 0x010

Type RW, reset -

	31	30	29	28	27	26	25	24	23	22	21	20	19	18	17	16
	VALUE															
Type	RW	RW	RW	RW	RW	RW	RW	RW	RW	RW	RW	RW	RW	RW	RW	RW
Reset	-	-	-	-	-	-	-	-	-	-	-	-	-	-	-	-
	15	14	13	12	11	10	9	8	7	6	5	4	3	2	1	0
	VALUE															
Type	RW	RW	RW	RW	RW	RW	RW	RW	RW	RW	RW	RW	RW	RW	RW	RW
Reset	-	-	-	-	-	-	-	-	-	-	-	-	-	-	-	-

Bit/Field	Name	Type	Reset	Description
-----------	------	------	-------	-------------

31:0	VALUE	RW	-	EEPROM Read or Write Data
------	-------	----	---	---------------------------

On a read, this field contains the value at the word pointed to by **EEOFFSET**. On a write, this field contains the data to be stored at the word pointed to by **EEOFFSET**. For writes, configuring this field starts the write process. If protection and access rules do not permit reads, all 1s are returned. If protection and access rules do not permit writes, the write fails and the **EEDONE** register indicates failure.

Register 21: EEPROM Read-Write with Increment (EERDWRINC), offset 0x014

The **EERDWRINC** register is used to read or write the EEPROM word at the address pointed to by the **EEBLOCK** and **EEOFFSET** registers, and then increment the **OFFSET** field in the **EEOFFSET** register. If the protection or access rules do not permit access, the operation is handled as follows: if reading is not allowed, the value 0xFFFF.FFFF is returned in all cases; if writing is not allowed, the **EEDONE** register is configured to indicate an error. In any case, the **OFFSET** field is incremented. If the last value is reached, **OFFSET** wraps around to 0 and points to the first word.

Note: A read of the **EERDWRINC** register during the EEPROM initialization sequence is only valid when the **WORKING** bit is 0 in **EEDONE** register:

EEPROM Read-Write with Increment (EERDWRINC)

Base 0x400A.F000

Offset 0x014

Type RW, reset -

	31	30	29	28	27	26	25	24	23	22	21	20	19	18	17	16
	VALUE															
Type	RW	RW	RW	RW	RW	RW	RW	RW	RW	RW	RW	RW	RW	RW	RW	RW
Reset	-	-	-	-	-	-	-	-	-	-	-	-	-	-	-	-
	15	14	13	12	11	10	9	8	7	6	5	4	3	2	1	0
	VALUE															
Type	RW	RW	RW	RW	RW	RW	RW	RW	RW	RW	RW	RW	RW	RW	RW	RW
Reset	-	-	-	-	-	-	-	-	-	-	-	-	-	-	-	-

Bit/Field	Name	Type	Reset	Description
31:0	VALUE	RW	-	<p>EEPROM Read or Write Data with Increment</p> <p>On a read, this field contains the value at the word pointed to by EEOFFSET. On a write, this field contains the data to be stored at the word pointed to by EEOFFSET. For writes, configuring this field starts the write process. If protection and access rules do not permit reads, all 1s are returned. If protection and access rules do not permit writes, the write fails and the EEDONE register indicates failure.</p> <p>Regardless of error, the OFFSET field in the EEOFFSET register is incremented by 1, and the value wraps around if the last word is reached.</p>

Register 22: EEPROM Done Status (EEDONE), offset 0x018

The **EEDONE** register indicates completion status of a write to the following registers:

- **EERDWR** or **EERDWRINC** register (for writes to the EEPROM memory)
- **EEPROT** register (for setting read and protection of the current block)
- **EEPASSn** registers (for configuring a password for a block)
- **EEDBGME** register (for mass erase of an EEPROM block)

This register can indicate if the write ended in an error or not. The **EEDONE** register can be used in conjunction with the **EEINT** register to indicate completion. The register can be **EEDONE** polled or read after an **EEINT** register interrupt fires. If any of the bit values in the **EEDONE** register are 1 after completion, then an error has occurred for that register write. If all of the bits are clear then the writes completed with success.

Note: Reads of the following registers during the EEPROM initialization sequence are only valid when the **WORKING** bit is 0 in **EEDONE** register:

- **EERDWR** or **EERDWRINC**
- **EEPROT**
- **EEPASSn**

EEPROM Done Status (EEDONE)

Base 0x400A.F000
 Offset 0x018
 Type RO, reset 0x0000.0000

	31	30	29	28	27	26	25	24	23	22	21	20	19	18	17	16	
	reserved																
Type	RO	RO	RO	RO	RO	RO	RO	RO	RO	RO	RO	RO	RO	RO	RO	RO	
Reset	0	0	0	0	0	0	0	0	0	0	0	0	0	0	0	0	
	15	14	13	12	11	10	9	8	7	6	5	4	3	2	1	0	
	reserved											WRBUSY	NOPERM	WKCOPY	WKERASE	reserved	WORKING
Type	RO	RO	RO	RO	RO	RO	RO	RO	RO	RO	RO	RO	RO	RO	RO	RO	
Reset	0	0	0	0	0	0	0	0	0	0	0	0	0	0	0	0	

Bit/Field	Name	Type	Reset	Description
31:6	reserved	RO	0x0000.0	Software should not rely on the value of a reserved bit. To provide compatibility with future products, the value of a reserved bit should be preserved across a read-modify-write operation.
5	WRBUSY	RO	0	Write Busy
				Value Description
				0 No error
				1 An attempt to access the EEPROM was made while a write was in progress.

Bit/Field	Name	Type	Reset	Description
4	NOPERM	RO	0	Write Without Permission Value Description 0 No error 1 An attempt was made to write without permission. This error can result because the block is locked, the write violates the programmed access protection, or when an attempt is made to write a password when the password has already been written.
3	WKCOPY	RO	0	Working on a Copy Value Description 0 The EEPROM is not copying. 1 A write is in progress and is waiting for the EEPROM to copy to or from the copy buffer.
2	WKERASE	RO	0	Working on an Erase Value Description 0 The EEPROM is not erasing. 1 A write is in progress and the original block is being erased after being copied.
1	reserved	RO	0	Software should not rely on the value of a reserved bit. To provide compatibility with future products, the value of a reserved bit should be preserved across a read-modify-write operation.
0	WORKING	RO	0	EEPROM Working Value Description 0 The EEPROM is not working. 1 The EEPROM is performing the requested operation.

Register 23: EEPROM Support Control and Status (EESUPP), offset 0x01C

The **EESUPP** register indicates if internal operations are required because an internal copy buffer must be erased or a programming failure has occurred and the operation must be completed. These conditions are explained below as well as in more detail in the section called “Error During Programming” on page 627.

- If either **PRETRY** or **ERETRY** is set indicating that an operation must be completed, setting the **START** bit causes the operation to be performed again
- The **PRETRY** and **ERETRY** bits are cleared automatically after the failed operation has been successfully completed.

These bits are not changed by reset, so any condition that occurred before a reset is still indicated after a reset.

EEPROM Support Control and Status (EESUPP)

Base 0x400A.F000
 Offset 0x01C
 Type RW, reset -

	31	30	29	28	27	26	25	24	23	22	21	20	19	18	17	16
	reserved															
Type	RO	RO	RO	RO	RO	RO	RO	RO	RO	RO	RO	RO	RO	RO	RO	RO
Reset	0	0	0	0	0	0	0	0	0	0	0	0	0	0	0	0
	15	14	13	12	11	10	9	8	7	6	5	4	3	2	1	0
	reserved												PRETRY	ERETRY	reserved	
Type	RO	RO	RO	RO	RO	RO	RO	RO	RO	RO	RO	RO	RO	RO	RO	RO
Reset	0	0	0	0	0	0	0	0	0	0	0	0	-	-	0	0

Bit/Field	Name	Type	Reset	Description
31:4	reserved	RO	0x0000.000	Software should not rely on the value of a reserved bit. To provide compatibility with future products, the value of a reserved bit should be preserved across a read-modify-write operation.
3	PRETRY	RO	-	Programming Must Be Retried Value Description 0 Programming has not failed. 1 Programming from a copy in either direction failed to complete.
2	ERETRY	RO	-	Erase Must Be Retried Value Description 0 Erasing has not failed. 1 Erasing failed to complete. If the failed erase is due to the erase of a main buffer, the copy is performed after the erase completes successfully.
1:0	reserved	RO	0	Software should not rely on the value of a reserved bit. To provide compatibility with future products, the value of a reserved bit should be preserved across a read-modify-write operation.

Register 24: EEPROM Unlock (EEUNLOCK), offset 0x020

The **EEUNLOCK** register can be used to unlock the whole EEPROM or a single block using a password. Unlocking is only required if a password is registered using the **EEPASSn** registers for the block that is selected by the **EEBLOCK** register. If block 0 has a password, it locks the remaining blocks from any type of access, but uses its own protection mechanism, for example readable, but not writable when locked. In addition, if block 0 has a password, it must be unlocked before unlocking any other block.

The **EEUNLOCK** register is written between 1 and 3 times to form the 32-bit, 64-bit, or 96-bit password registered using the **EEPASSn** registers. The value used to configure the **EEPASS0** register must always be written last. For example, for a 96-bit password, the value used to configure the **EEPASS2** register must be written first followed by the **EEPASS1** and **EEPASS0** register values. The block or the whole EEPROM can be re-locked by writing 0xFFFF.FFFF to this register.

In the event that an invalid value is written to this register, the block remains locked. The state of the EEPROM lock can be determined by reading back the **EEUNLOCK** register. If a multi-word password is set and the number of words written is incorrect, writing 0xFFFF.FFFF to this register reverts the EEPROM lock to the locked state, and the proper unlock sequence can be retried.

Note that the internal logic is balanced to prevent any electrical or time-based attack being used to find the correct password or its length.

Note: A read of the **EEUNLOCK** register during the EEPROM initialization sequence is only valid when the **WORKING** bit is 0 in **EEDONE** register:

EEPROM Unlock (EEUNLOCK)

Base 0x400A.F000
Offset 0x020
Type RW, reset -

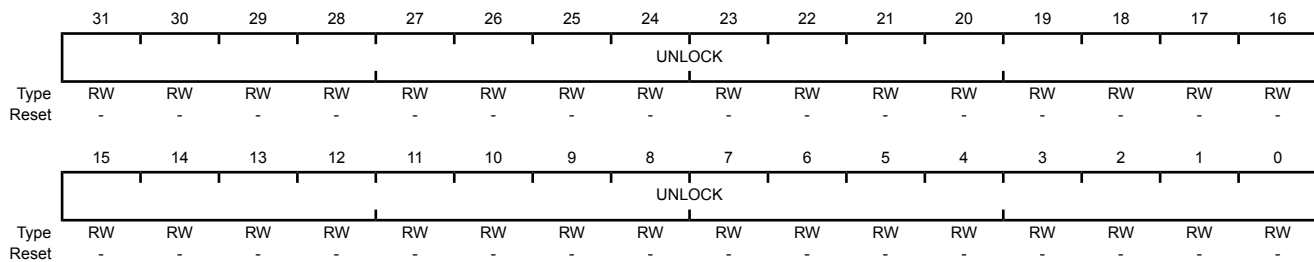

Bit/Field	Name	Type	Reset	Description
31:0	UNLOCK	RW	-	EEPROM Unlock

Value	Description
0	The EEPROM is locked.
1	The EEPROM is unlocked.

The EEPROM is locked if the block referenced by the **EEBLOCK** register has a password registered, or if the master block (block 0) has a password. Unlocking is performed by writing the password to this register. The block or the EEPROM stays unlocked until it is locked again or until the next reset. It can be locked again by writing 0xFFFF.FFFF to this register.

Register 25: EEPROM Protection (EEPROT), offset 0x030

The **EEPROT** register is used to set or read the protection for the current block, as selected by the **EEBLOCK** register. Protection and access control is used to determine when a block's contents can be read or written.

Note: A read of the **EEPROT** register during the EEPROM initialization sequence is only valid when the **WORKING** bit is 0 in **EEDONE** register:

EEPROM Protection (EEPROT)

Base 0x400A.F000
 Offset 0x030
 Type RW, reset 0x0000.0000

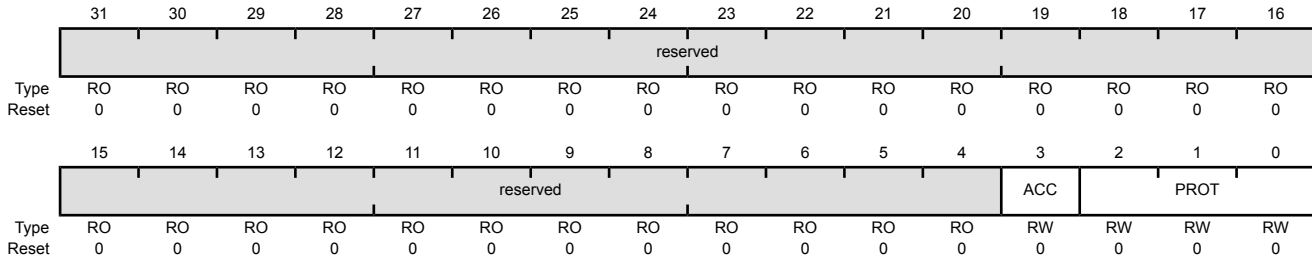

Bit/Field	Name	Type	Reset	Description
31:4	reserved	RO	0x0000.000	Software should not rely on the value of a reserved bit. To provide compatibility with future products, the value of a reserved bit should be preserved across a read-modify-write operation.
3	ACC	RW	0	Access Control
				Value Description
				0 Both user and supervisor code may access this block of the EEPROM.
				1 Only supervisor code may access this block of the EEPROM. μ DMA and Debug are also prevented from accessing the EEPROM.
				If this bit is set for block 0, then the whole EEPROM may only be accessed by supervisor code.

Bit/Field	Name	Type	Reset	Description										
2:0	PROT	RW	0x0	<p>Protection Control</p> <p>The Protection bits control what context is needed for reading and writing the block selected by the EEBLOCK register, or if block 0 is selected, all blocks. The following values are allowed:</p> <table><thead><tr><th>Value</th><th>Description</th></tr></thead><tbody><tr><td>0x0</td><td><p>This setting is the default.</p><p>Without password: the block is not protected and is readable and writable at any time.</p><p>With password: the block is readable, but only writable when unlocked.</p></td></tr><tr><td>0x1</td><td><p>With password: the block is readable or writable only when unlocked.</p><p>This value has no meaning when there is no password.</p></td></tr><tr><td>0x2</td><td><p>Without password: the block is readable, not writable.</p><p>With password: the block is readable only when unlocked, but is not writable under any conditions.</p></td></tr><tr><td>0x3</td><td>Reserved</td></tr></tbody></table>	Value	Description	0x0	<p>This setting is the default.</p> <p>Without password: the block is not protected and is readable and writable at any time.</p> <p>With password: the block is readable, but only writable when unlocked.</p>	0x1	<p>With password: the block is readable or writable only when unlocked.</p> <p>This value has no meaning when there is no password.</p>	0x2	<p>Without password: the block is readable, not writable.</p> <p>With password: the block is readable only when unlocked, but is not writable under any conditions.</p>	0x3	Reserved
Value	Description													
0x0	<p>This setting is the default.</p> <p>Without password: the block is not protected and is readable and writable at any time.</p> <p>With password: the block is readable, but only writable when unlocked.</p>													
0x1	<p>With password: the block is readable or writable only when unlocked.</p> <p>This value has no meaning when there is no password.</p>													
0x2	<p>Without password: the block is readable, not writable.</p> <p>With password: the block is readable only when unlocked, but is not writable under any conditions.</p>													
0x3	Reserved													

Register 26: EEPROM Password (EEPASS0), offset 0x034**Register 27: EEPROM Password (EEPASS1), offset 0x038****Register 28: EEPROM Password (EEPASS2), offset 0x03C**

The **EEPASSn** registers are used to configure a password for a block. A password may only be set once and cannot be changed. The password may be 32-bits, 64-bits, or 96-bits. Each word of the password can be any 32-bit value other than 0xFFFF.FFFF (all 1s). To set a password, the **EEPASS0** register is written to with a value other than 0xFFFF.FFFF. When the write completes, as indicated in the **EEDONE** register, the application may choose to write to the **EEPASS1** register with a value other than 0xFFFF.FFFF. When that write completes, the application may choose to write to the **EEPASS2** register with a value other than 0xFFFF.FFFF to create a 96-bit password. The registers do not have to be written consecutively, and the **EEPASS1** and **EEPASS2** registers may be written at a later date. Based on whether 1, 2, or all 3 registers have been written, the unlock code also requires the same number of words to unlock.

Note: Once the password is written, the block is not actually locked until either a reset occurs or 0xFFFF.FFFF is written to **EEUNLOCK**.

Note: A read of the **EEPASSn** register during the EEPROM initialization sequence is only valid when the **WORKING** bit is 0 in **EEDONE** register:

EEPROM Password (EEPASSn)

Base 0x400A.F000

Offset 0x034

Type RW, reset -

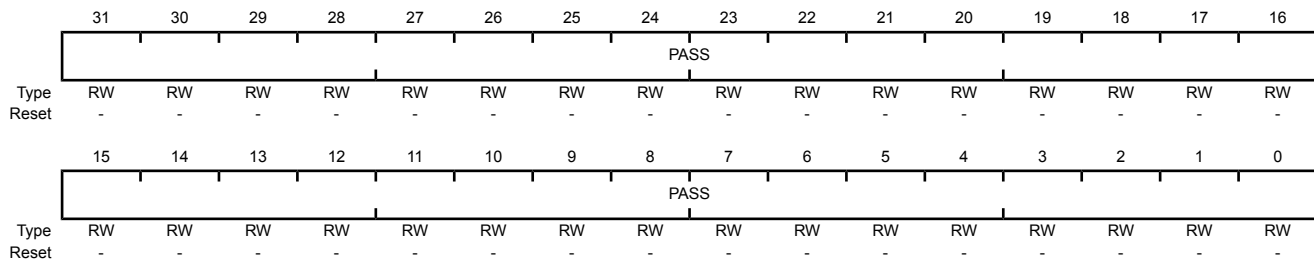

Bit/Field	Name	Type	Reset	Description
31:0	PASS	RW	-	Password This register reads as 0x1 if a password is registered for this block and 0x0 if no password is registered. A write to this register if it reads as 0x0 sets the password. If an attempt is made to write to this register when it reads as 0x1, the write is ignored and the NOPERM bit in the EEDONE register is set.

Register 29: EEPROM Interrupt (EEINT), offset 0x040

The **EEINT** register is used to control whether an interrupt should be generated when a write to EEPROM completes as indicated by the **EEDONE** register value changing from 0x1 to any other value. If the **INT** bit in this register is set, the **ERIS** bit in the **Flash Controller Raw Interrupt Status (FCRIS)** register is set whenever the **EEDONE** register value changes from 0x1 as the Flash memory and the EEPROM share an interrupt vector.

EEPROM Interrupt (EEINT)

Base 0x400A.F000

Offset 0x040

Type RW, reset 0x0000.0000

	31	30	29	28	27	26	25	24	23	22	21	20	19	18	17	16
	reserved															
Type	RO	RO	RO	RO	RO	RO	RO	RO	RO	RO	RO	RO	RO	RO	RO	RO
Reset	0	0	0	0	0	0	0	0	0	0	0	0	0	0	0	0
	15	14	13	12	11	10	9	8	7	6	5	4	3	2	1	0
	reserved															INT
Type	RO	RO	RO	RO	RO	RO	RO	RO	RO	RO	RO	RO	RO	RO	RO	RW
Reset	0	0	0	0	0	0	0	0	0	0	0	0	0	0	0	0

Bit/Field	Name	Type	Reset	Description
31:1	reserved	RO	0x0000.000	Software should not rely on the value of a reserved bit. To provide compatibility with future products, the value of a reserved bit should be preserved across a read-modify-write operation.
0	INT	RW	0	Interrupt Enable
				Value Description
				0 No interrupt is generated.
				1 An interrupt is generated when the EEDONE register transitions from 1 to 0 or an error occurs. The EEDONE register provides status after a write to an offset location as well as a write to the password and protection bits.

Register 30: EEPROM Block Hide 0 (EEHIDE0), offset 0x050

The **EEHIDE0** register is used to hide one or more blocks other than EEPROM block 0. Bits 1 through 31 of this register correspond to EEPROM blocks 1 through 31. Once hidden, the block is not accessible until the next reset. This model allows initialization code to have access to data which is not visible to the rest of the application. This register also provides for additional security in that there is no password to search for in the code or data.

EEPROM Block Hide 0 (EEHIDE0)

Base 0x400A.F000
 Offset 0x050
 Type RW, reset 0x0000.0000

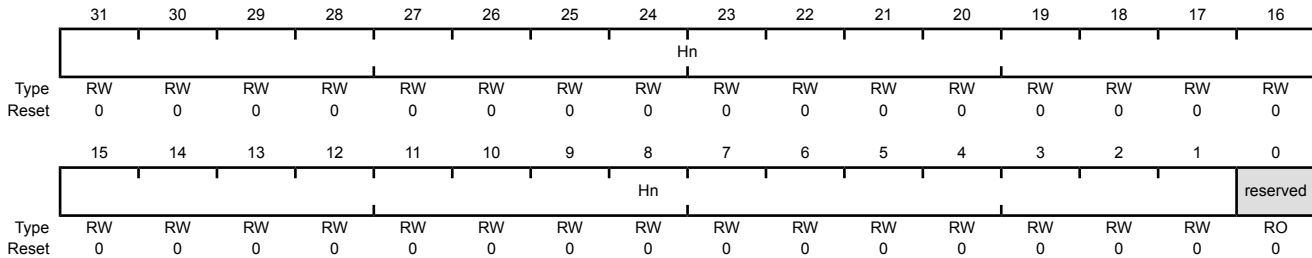

Bit/Field	Name	Type	Reset	Description
31:1	Hn	RW	0x0000.000	Hide Block

Value	Description
0	The corresponding block is not hidden.
1	The block number that corresponds to the bit number is hidden. A hidden block cannot be accessed, and the OFFSET value in the EEBLOCK register cannot be set to that block number. If an attempt is made to configure the OFFSET field to a hidden block, the EEBLOCK register is cleared. Any attempt to clear a bit in this register that is set is ignored.

0	reserved	RO	0	Software should not rely on the value of a reserved bit. To provide compatibility with future products, the value of a reserved bit should be preserved across a read-modify-write operation.
---	----------	----	---	---

Register 31: EEPROM Block Hide 1 (EEHIDE1), offset 0x054**Register 32: EEPROM Block Hide 2 (EEHIDE2), offset 0x058**

The **EEHIDE** register is used to hide one or more blocks. Bits 0 through 31 of the EEHIDE1 register correspond to EEPROM blocks 32 through 63. Bits 0 through 31 of the EEHIDE2 register correspond to EEPROM blocks 64 through 95. Once hidden, the block is not accessible until the next reset. This model allows initialization code to have access to data which is not visible to the rest of the application. This register also provides for additional security in that there is no password to search for in the code or data.

EEPROM Block Hide n (EEHIDEn)

Base 0x400A.F000

Offset 0x054

Type RW, reset 0x0000.0000

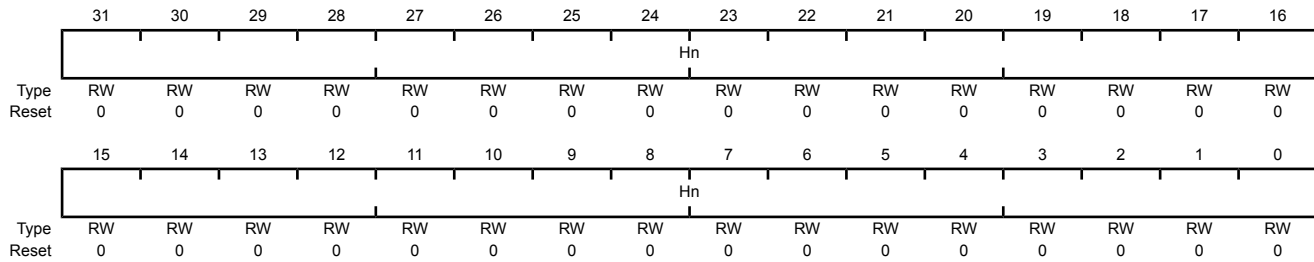

Bit/Field	Name	Type	Reset	Description
31:0	Hn	RW	0x0000.000	Hide Block

Value Description

- | | |
|---|--|
| 0 | The corresponding block is not hidden. |
| 1 | The block number that corresponds to the bit number is hidden. A hidden block cannot be accessed, and the OFFSET value in the EEBLOCK register cannot be set to that block number. If an attempt is made to configure the OFFSET field to a hidden block, the EEBLOCK register is cleared. |
- Any attempt to clear a bit in this register that is set is ignored.

Register 33: EEPROM Debug Mass Erase (EEDBGME), offset 0x080

The **EEDBGME** register is used to mass erase the EEPROM block back to its default state from the factory. This register is intended to be used only for debug and test purposes, not in production environments. The erase takes place in such a way as to be secure. It first erases all data and then erases the protection mechanism. This register can only be written from supervisor mode by the core, and can also be written by the Tiva™ C Series debug controller when enabled. A key is used to avoid accidental use of this mechanism. Note that if a power down takes place while erasing, the mechanism should be used again to complete the operation. Powering off prematurely does not expose secured data.

To start a mass erase, the whole register must be written as 0xE37B.0001. The register reads back as 0x1 until the erase is fully completed at which time it reads as 0x0. The **EEDONE** register is set to 0x1 when the erase is started and changes to 0x0 or an error when the mass erase is complete.

EEPROM Debug Mass Erase (EEDBGME)

Base 0x400A.F000

Offset 0x080

Type RW, reset 0x0000.0000

	31	30	29	28	27	26	25	24	23	22	21	20	19	18	17	16
	KEY															
Type	WO	WO	WO	WO	WO	WO	WO	WO	WO	WO	WO	WO	WO	WO	WO	WO
Reset	0	0	0	0	0	0	0	0	0	0	0	0	0	0	0	0
	15	14	13	12	11	10	9	8	7	6	5	4	3	2	1	0
	reserved															ME
Type	RO	RO	RO	RO	RO	RO	RO	RO	RO	RO	RO	RO	RO	RO	RO	RW
Reset	0	0	0	0	0	0	0	0	0	0	0	0	0	0	0	0

Bit/Field	Name	Type	Reset	Description
31:16	KEY	WO	0x0000	Erase Key This field must be written with 0xE37B for the ME field to be effective.
15:1	reserved	RO	0x000	Software should not rely on the value of a reserved bit. To provide compatibility with future products, the value of a reserved bit should be preserved across a read-modify-write operation.
0	ME	RW	0	Mass Erase
	Value	Description		
	0	No action.		
	1	When written as a 1, the EEPROM is mass erased. This bit continues to read as 1 until the EEPROM is fully erased.		

Register 34: EEPROM Peripheral Properties (EEPROMPP), offset 0xFC0

The **EEPROMPP** register indicates the size of the EEPROM for this part.

EEPROM Peripheral Properties (EEPROMPP)

Base 0x400A.F000

Offset 0xFC0

Type RO, reset 0x0000.01FF

	31	30	29	28	27	26	25	24	23	22	21	20	19	18	17	16
	reserved															
Type	RO	RO	RO	RO	RO	RO	RO	RO	RO	RO	RO	RO	RO	RO	RO	RO
Reset	0	0	0	0	0	0	0	0	0	0	0	0	0	0	0	0
	15	14	13	12	11	10	9	8	7	6	5	4	3	2	1	0
	SIZE															
Type	RO	RO	RO	RO	RO	RO	RO	RO	RO	RO	RO	RO	RO	RO	RO	RO
Reset	0	0	0	0	0	0	0	1	1	1	1	1	1	1	1	1

Bit/Field	Name	Type	Reset	Description
31:16	reserved	RO	0x0	Software should not rely on the value of a reserved bit. To provide compatibility with future products, the value of a reserved bit should be preserved across a read-modify-write operation.
15:0	SIZE	RO	0x1FF	EEPROM Size Indicates the size of the on-chip EEPROM. Any values not shown are reserved.
	Value	Description		
	0x0000	64 bytes of EEPROM		
	0x0001	128 bytes of EEPROM		
	0x0003	256 bytes of EEPROM		
	0x0007	512 bytes of EEPROM		
	0x000F	1 KB of EEPROM		
	0x001F	2 KB of EEPROM		
	0x003F	3 KB of EEPROM		
	0x007F	4 KB of EEPROM		
	0x00FF	5 KB of EEPROM		
	0x01FF	6 KB of EEPROM		

8.6 Memory Register Descriptions (System Control Offset)

The remainder of this section lists and describes the registers that reside in the System Control address space, in numerical order by address offset. Registers in this section are relative to the System Control base address of 0x400F.E000.

Register 35: Reset Vector Pointer (RVP), offset 0x0D4

The **Reset Vector Pointer (RVP)** register contains the address of the reset vector of the software module that is to be executed after boot loader execution. The **RVP** register is initialized by a power-on reset.

Reset Vector Pointer (RVP)

Base 0x400F.E000
 Offset 0x0D4
 Type RO, reset 0x0101.FFF0

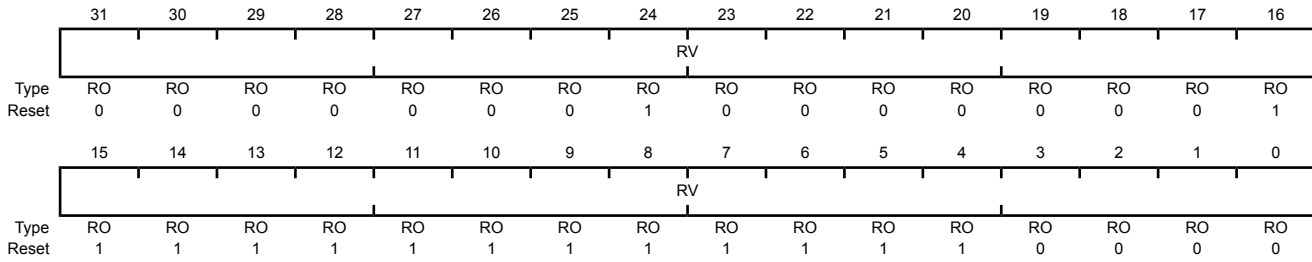

Bit/Field	Name	Type	Reset	Description
31:0	RV	RO	0x0101.FFF0	Reset Vector Pointer Address

Register 36: Flash Memory Protection Read Enable 0 (FMPRE0), offset 0x200

Register 37: Flash Memory Protection Read Enable 1 (FMPRE1), offset 0x204

Register 38: Flash Memory Protection Read Enable 2 (FMPRE2), offset 0x208

Register 39: Flash Memory Protection Read Enable 3 (FMPRE3), offset 0x20C

Register 40: Flash Memory Protection Read Enable 4 (FMPRE4), offset 0x210

Register 41: Flash Memory Protection Read Enable 5 (FMPRE5), offset 0x214

Register 42: Flash Memory Protection Read Enable 6 (FMPRE6), offset 0x218

Register 43: Flash Memory Protection Read Enable 7 (FMPRE7), offset 0x21C

Register 44: Flash Memory Protection Read Enable 8 (FMPRE8), offset 0x220

Register 45: Flash Memory Protection Read Enable 9 (FMPRE9), offset 0x224

Register 46: Flash Memory Protection Read Enable 10 (FMPRE10), offset 0x228

Register 47: Flash Memory Protection Read Enable 11 (FMPRE11), offset 0x22C

Register 48: Flash Memory Protection Read Enable 12 (FMPRE12), offset 0x230

Register 49: Flash Memory Protection Read Enable 13 (FMPRE13), offset 0x234

Register 50: Flash Memory Protection Read Enable 14 (FMPRE14), offset 0x238

Register 51: Flash Memory Protection Read Enable 15 (FMPRE15), offset 0x23C

Note: The **FMPRE0** register is aliased for backwards compatibility.

Note: Offset is relative to System Control base address of 0x400F.E000.

This register stores the read-only protection bits for each 2-KB flash block (**FMPPEn** stores the execute-only bits). Note that for protecting sectors, eight bits need to be cleared to create a 16-KB read-protected sector.

This register is loaded during the power-on reset sequence. The factory settings for the **FMPREn** and **FMPPEn** registers are a value of 1 for all implemented banks. This achieves a policy of open access and programmability. The register bits may be changed by writing the specific register bit. However, this register is RW0; the user can only change the protection bit from a 1 to a 0 (and may NOT change a 0 to a 1). The changes are not permanent until the register is committed (saved), at which point the bit change is permanent. If a bit is changed from a 1 to a 0 and not committed, it may be restored by executing a power-on reset sequence. The reset value shown only applies to power-on reset; any other type of reset does not affect this register. Once committed, the only way to restore the factory default value of this register is to perform the "Recover Locked Device" sequence detailed in the JTAG chapter.

Each **FMPREn** register controls a 64K block. For additional information, see "Protected Flash Memory Registers" on page 617.

- **FMPRE0:** 0 to 64 KB
- **FMPRE1:** 65 to 128 KB
- **FMPRE2:** 129 to 192 KB
- **FMPRE3:** 193 to 256 KB
- **FMPRE4:** 257 to 320 KB
- **FMPRE5:** 321 to 384 KB
- **FMPRE6:** 385 to 448 KB
- **FMPRE7:** 449 to 512 KB
- **FMPRE8:** 513 to 576 KB
- **FMPRE9:** 577 to 640 KB
- **FMPRE10:** 641 to 704 KB
- **FMPRE11:** 705 to 768 KB
- **FMPRE12:** 769 to 832 KB
- **FMPRE13:** 833 to 896 KB
- **FMPRE14:** 897 to 960 KB
- **FMPRE15:** 961 to 1024 KB

Flash Memory Protection Read Enable n (FMPREn)

Base 0x400F.E000
 Offset 0x200
 Type RW, reset 0xFFFF.FFFF

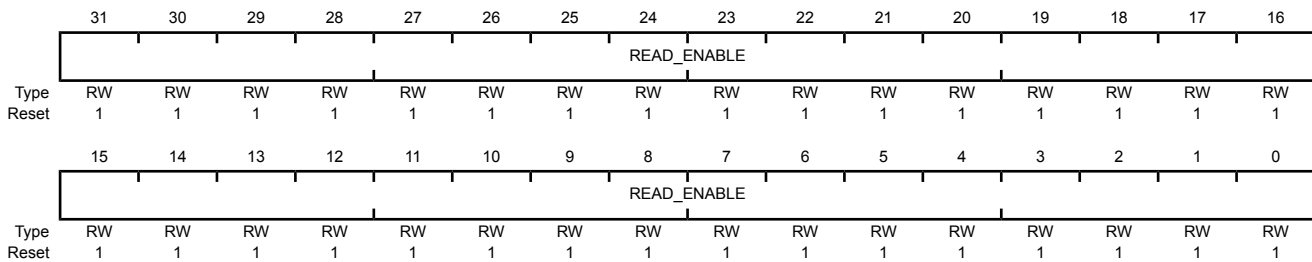

Bit/Field	Name	Type	Reset	Description
31:0	READ_ENABLE	RW	0xFFFF.FFFF	Flash Read Enable Each bit configures a 2-KB flash block to be read only. Note that for read-protection of sectors, eight bits need to be cleared to create a 16-KB read-protected sector. The policies may be combined as shown in the table "Flash Protection Policy Combinations".

Register 52: Flash Memory Protection Program Enable 0 (FMPPE0), offset 0x400

Register 53: Flash Memory Protection Program Enable 1 (FMPPE1), offset 0x404

Register 54: Flash Memory Protection Program Enable 2 (FMPPE2), offset 0x408

Register 55: Flash Memory Protection Program Enable 3 (FMPPE3), offset 0x40C

Register 56: Flash Memory Protection Program Enable 4 (FMPPE4), offset 0x410

Register 57: Flash Memory Protection Program Enable 5 (FMPPE5), offset 0x414

Register 58: Flash Memory Protection Program Enable 6 (FMPPE6), offset 0x418

Register 59: Flash Memory Protection Program Enable 7 (FMPPE7), offset 0x41C

Register 60: Flash Memory Protection Program Enable 8 (FMPPE8), offset 0x420

Register 61: Flash Memory Protection Program Enable 9 (FMPPE9), offset 0x424

Register 62: Flash Memory Protection Program Enable 10 (FMPPE10), offset 0x428

Register 63: Flash Memory Protection Program Enable 11 (FMPPE11), offset 0x42C

Register 64: Flash Memory Protection Program Enable 12 (FMPPE12), offset 0x430

Register 65: Flash Memory Protection Program Enable 13 (FMPPE13), offset 0x434

Register 66: Flash Memory Protection Program Enable 14 (FMPPE14), offset 0x438

Register 67: Flash Memory Protection Program Enable 15 (FMPPE15), offset 0x43C

Note: The **FMPPE0** register is aliased for backwards compatibility.

Note: Offset is relative to System Control base address of 0x400FE000.

This register stores the execute-only protection bits for each 2-KB flash block (**FMPPE_n** stores the read-only protection bits). Since the memory is two-way interleaved and each bank individually is an 8-KB sector, read-only protection must occur across a block size of 16-KB. No smaller block size

is supported. Note that the **Flash Memory Protection Read (FMPREn)** registers do allow read-protection of a block as small as 2 KB, unlike the **FMPPEn** registers.

Thus, in order to execute-only protect a 16-KB block, a user must program the entire eight bits of the byte to the same value. For example, to protect the first 16-KB block, bits [7:0] of the **FMPPE0** register need to be cleared to all 0s.

This register is loaded during the power-on reset sequence. The factory settings for the **FMPREn** and **FMPPEn** registers are a value of 1 for all implemented banks. This achieves a policy of open access and programmability. This register is RW0; the user can only change the protection byte from all 1s to all 0s (and may NOT change from all 0 to all 1). The changes are not permanent until the register is committed (saved), at which point the byte change is permanent. If a byte is changed from all 1s to all 0s and not committed, it may be restored by executing a power-on reset sequence. The reset value shown only applies to power-on reset; any other type of reset does not affect this register. Once committed, the only way to restore the factory default value of this register is to perform the "Recover Locked Device" sequence detailed in the JTAG chapter. For additional information, see "Protected Flash Memory Registers" on page 617.

Each **FMPPEn** register controls a 64K block. For additional information, see "Protected Flash Memory Registers" on page 617.

- **FMPPE0**: 0 to 64 KB
- **FMPPE1**: 65 to 128 KB
- **FMPPE2**: 129 to 192 KB
- **FMPPE3**: 193 to 256 KB
- **FMPPE4**: 257 to 320 KB
- **FMPPE5**: 321 to 384 KB
- **FMPPE6**: 385 to 448 KB
- **FMPPE7**: 449 to 512 KB
- **FMPPE8**: 513 to 576 KB
- **FMPPE9**: 577 to 640 KB
- **FMPPE10**: 641 to 704 KB
- **FMPPE11**: 705 to 768 KB
- **FMPPE12**: 769 to 832 KB
- **FMPPE13**: 833 to 896 KB
- **FMPPE14**: 897 to 960 KB
- **FMPPE15**: 961 to 1024 KB

Flash Memory Protection Program Enable n (FMPPEn)

Base 0x400F.E000
 Offset 0x400
 Type RW, reset 0xFFFF.FFFF

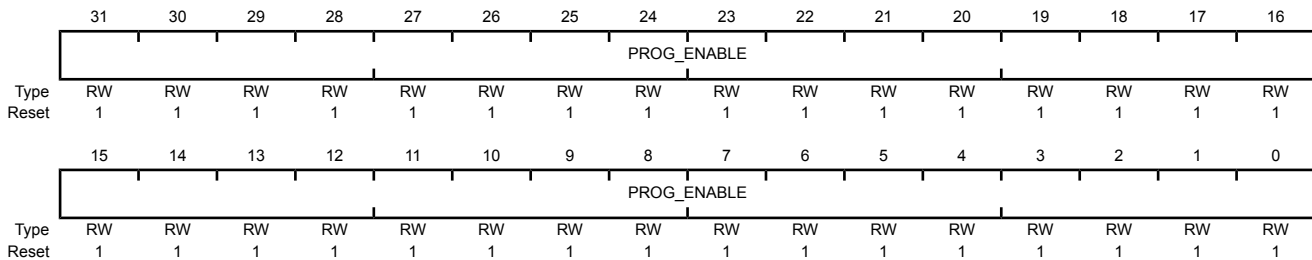

Bit/Field	Name	Type	Reset	Description
31:0	PROG_ENABLE	RW	0xFFFF.FFFF	Flash Programming Enable Every eighth bit programs an 16-KB flash sector to be execute only. The policies may be combined as shown in Table 8-2 on page 618.

Register 68: Boot Configuration (BOOTCFG), offset 0x1D0

Note: Offset is relative to System Control base address of 0x400F.E000.

Note: The **Boot Configuration (BOOTCFG)** register requires a POR before the committed changes take effect.

This register is not written directly, but instead uses the **FMD** register as explained in “Non-Volatile Register Programming-- Flash Memory Resident Registers” on page 621. When this register is committed, the new value cannot be read back until after the power cycle. This register provides configuration of a GPIO pin to enable the ROM Boot Loader as well as a write-once mechanism to disable external debugger access to the device. At reset, the user has the opportunity to direct the core to execute the ROM Boot Loader or the application in Flash memory by using any GPIO signal from Ports A through H as configured by the bits in this register. At reset, the following sequence is performed:

1. The **BOOTCFG** register is read. If the **EN** bit is clear, the ROM Boot Loader is executed.
2. In the ROM Boot Loader, the status of the specified GPIO pin is compared with the specified polarity. If the status matches the specified polarity, the ROM is mapped to address 0x0000.0000 and execution continues out of the ROM Boot Loader.
3. If the **EN** bit is set or the status doesn't match the specified polarity, the data at address 0x0000.0004 is read, and if the data at this address is 0xFFFF.FFFF, the ROM is mapped to address 0x0000.0000 and execution continues out of the ROM Boot Loader.
4. If there is data at address 0x0000.0004 that is not 0xFFFF.FFFF, the stack pointer (**SP**) is loaded from Flash memory at address 0x0000.0000 and the program counter (**PC**) is loaded from address 0x0000.0004. The user application begins executing.

The **DBG0** bit is cleared by the factory and the **DBG1** bit is set, which enables external debuggers. Clearing the **DBG1** bit disables any external debugger access to the device, starting with the next power-up cycle of the device. The **NW** bit indicates that bits in the register can be changed from 1 to 0.

By committing the register values using the **COMT** bit in the **FMC** register, the register contents become non-volatile and are therefore retained following power cycling. Prior to being committed, bits can only be changed from 1 to 0. The reset value shown only applies to power-on reset when the register is not yet committed; any other type of reset does not affect this register. Once committed, the register retains its value through power-on reset. Once committed, the only way to restore the factory default value of this register is to perform the sequence detailed in “Recovering a “Locked” Microcontroller” on page 220.

Boot Configuration (BOOTCFG)

Base 0x400F.E000
 Offset 0x1D0
 Type RO, reset 0xFFFF.FFFE

	31	30	29	28	27	26	25	24	23	22	21	20	19	18	17	16	
	NW	reserved															
Type	RO	RO	RO	RO	RO	RO	RO	RO	RO	RO	RO	RO	RO	RO	RO	RO	
Reset	1	1	1	1	1	1	1	1	1	1	1	1	1	1	1	1	
	15	14	13	12	11	10	9	8	7	6	5	4	3	2	1	0	
	PORT			PIN			POL	EN	reserved				KEY	reserved		DBG1	DBG0
Type	RO	RO	RO	RO	RO	RO	RO	RO	RO	RO	RO	RO	RO	RO	RO	RO	
Reset	1	1	1	1	1	1	1	1	1	1	1	1	1	1	1	0	

Bit/Field	Name	Type	Reset	Description																		
31	NW	RO	1	Not Written When set, this bit indicates that the values in this register can be changed from 1 to 0. When clear, this bit specifies that the contents of this register cannot be changed.																		
30:16	reserved	RO	0xFFFF	Software should not rely on the value of a reserved bit. To provide compatibility with future products, the value of a reserved bit should be preserved across a read-modify-write operation.																		
15:13	PORT	RO	0x7	<p>Boot GPIO Port This field selects the port of the GPIO port pin that enables the ROM boot loader at reset.</p> <p>Note: The selected port can be reprogrammed for a different function after reset.</p> <table border="1"> <thead> <tr> <th>Value</th> <th>Description</th> </tr> </thead> <tbody> <tr><td>0x0</td><td>Port A</td></tr> <tr><td>0x1</td><td>Port B</td></tr> <tr><td>0x2</td><td>Port C</td></tr> <tr><td>0x3</td><td>Port D</td></tr> <tr><td>0x4</td><td>Port E</td></tr> <tr><td>0x5</td><td>Port F</td></tr> <tr><td>0x6</td><td>Port G</td></tr> <tr><td>0x7</td><td>Port H</td></tr> </tbody> </table>	Value	Description	0x0	Port A	0x1	Port B	0x2	Port C	0x3	Port D	0x4	Port E	0x5	Port F	0x6	Port G	0x7	Port H
Value	Description																					
0x0	Port A																					
0x1	Port B																					
0x2	Port C																					
0x3	Port D																					
0x4	Port E																					
0x5	Port F																					
0x6	Port G																					
0x7	Port H																					
12:10	PIN	RO	0x7	<p>Boot GPIO Pin This field selects the pin number of the GPIO port pin that enables the ROM boot loader at reset.</p> <table border="1"> <thead> <tr> <th>Value</th> <th>Description</th> </tr> </thead> <tbody> <tr><td>0x0</td><td>Pin 0</td></tr> <tr><td>0x1</td><td>Pin 1</td></tr> <tr><td>0x2</td><td>Pin 2</td></tr> <tr><td>0x3</td><td>Pin 3</td></tr> <tr><td>0x4</td><td>Pin 4</td></tr> <tr><td>0x5</td><td>Pin 5</td></tr> <tr><td>0x6</td><td>Pin 6</td></tr> <tr><td>0x7</td><td>Pin 7</td></tr> </tbody> </table>	Value	Description	0x0	Pin 0	0x1	Pin 1	0x2	Pin 2	0x3	Pin 3	0x4	Pin 4	0x5	Pin 5	0x6	Pin 6	0x7	Pin 7
Value	Description																					
0x0	Pin 0																					
0x1	Pin 1																					
0x2	Pin 2																					
0x3	Pin 3																					
0x4	Pin 4																					
0x5	Pin 5																					
0x6	Pin 6																					
0x7	Pin 7																					
9	POL	RO	1	<p>Boot GPIO Polarity When set, this bit selects a high level for the GPIO port pin to enable the ROM boot loader at reset. When clear, this bit selects a low level for the GPIO port pin.</p>																		

Bit/Field	Name	Type	Reset	Description
8	EN	RO	1	<p>Boot GPIO Enable</p> <p>Clearing this bit enables the use of a GPIO pin to enable the ROM Boot Loader at reset. When this bit is set, the contents of address 0x0000.0004 are checked to see if the Flash memory has been programmed. If the contents are not 0xFFFF.FFFF, the core executes out of Flash memory. If the Flash has not been programmed, the core executes out of ROM.</p>
7:5	reserved	RO	0x7	Software should not rely on the value of a reserved bit. To provide compatibility with future products, the value of a reserved bit should be preserved across a read-modify-write operation.
4	KEY	RO	1	<p>KEY Select</p> <p>This bit chooses between using the value 0xA442 or the <code>PEKEY</code> value in the FLPEKEY register as the <code>WRKEY</code> value in the FMC/FMC2 register.</p> <p>Value Description</p> <p>0 The <code>PEKEY</code> value in the FLPEKEY register is committed by user and used as the <code>WRKEY</code> in the FMC/FMC2 register. Writes to FMC/FMC2 register with a 0xA442 key are ignored.</p> <p>1 0xA442 is used as key</p>
3:2	reserved	RO	0x3	Software should not rely on the value of a reserved bit. To provide compatibility with future products, the value of a reserved bit should be preserved across a read-modify-write operation.
1	DBG1	RO	1	<p>Debug Control 1</p> <p>The <code>DBG1</code> bit must be 1 and <code>DBG0</code> must be 0 for debug to be available.</p>
0	DBG0	RO	0	<p>Debug Control 0</p> <p>The <code>DBG1</code> bit must be 1 and <code>DBG0</code> must be 0 for debug to be available.</p>

Register 69: User Register 0 (USER_REG0), offset 0x1E0

Register 70: User Register 1 (USER_REG1), offset 0x1E4

Register 71: User Register 2 (USER_REG2), offset 0x1E8

Register 72: User Register 3 (USER_REG3), offset 0x1EC

Note: Offset is relative to System Control base address of 0x400F.E000.

These registers each provide 32 bits of user-defined data that is non-volatile. Bits can only be changed from 1 to 0. The reset value shown only applies to power-on reset when the register is not yet committed; any other type of reset does not affect this register. Once committed, the register retains its value through power-on reset. The only way to restore the factory default value of this register is to perform the "Recover Locked Device" sequence detailed in the JTAG section.

User Register n (USER_REGn)

Base 0x400F.E000

Offset 0x1E0

Type W0, reset 0xFFFF.FFFF

	31	30	29	28	27	26	25	24	23	22	21	20	19	18	17	16
	DATA															
Type	RW	RW	RW	RW	RW	RW	RW	RW	RW	RW	RW	RW	RW	RW	RW	RW
Reset	1	1	1	1	1	1	1	1	1	1	1	1	1	1	1	1
	15	14	13	12	11	10	9	8	7	6	5	4	3	2	1	0
	DATA															
Type	RW	RW	RW	RW	RW	RW	RW	RW	RW	RW	RW	RW	RW	RW	RW	RW
Reset	1	1	1	1	1	1	1	1	1	1	1	1	1	1	1	1

Bit/Field	Name	Type	Reset	Description
31:0	DATA	RW	0xFFFF.FFFF	User Data Contains the user data value. This field is initialized to all 1s and once committed, retains its value through power-on reset.

9 Micro Direct Memory Access (μ DMA)

The TM4C129ENCPDT microcontroller includes a Direct Memory Access (DMA) controller, known as micro-DMA (μ DMA). The μ DMA controller provides a way to offload data transfer tasks from the Cortex™-M4F processor, allowing for more efficient use of the processor and the available bus bandwidth. The μ DMA controller can perform transfers between memory and peripherals. It has dedicated channels for each supported on-chip module and can be programmed to automatically perform transfers between peripherals and memory as the peripheral is ready to transfer more data. The μ DMA controller provides the following features:

- ARM® PrimeCell® 32-channel configurable μ DMA controller
- Support for memory-to-memory, memory-to-peripheral, and peripheral-to-memory in multiple transfer modes
 - Basic for simple transfer scenarios
 - Ping-pong for continuous data flow
 - Scatter-gather for a programmable list of up to 256 arbitrary transfers initiated from a single request
- Highly flexible and configurable channel operation
 - Independently configured and operated channels
 - Dedicated channels for supported on-chip modules
 - Flexible channel assignments
 - One channel each for receive and transmit path for bidirectional modules
 - Dedicated channel for software-initiated transfers
 - Per-channel configurable priority scheme
 - Optional software-initiated requests for any channel
- Two levels of priority
- Design optimizations for improved bus access performance between μ DMA controller and the processor core
 - μ DMA controller access is subordinate to core access
 - RAM striping
 - Peripheral bus segmentation
- Data sizes of 8, 16, and 32 bits
- Transfer size is programmable in binary steps from 1 to 1024
- Source and destination address increment size of byte, half-word, word, or no increment

- Maskable peripheral requests
- Interrupt on transfer completion, with a separate interrupt per channel

9.1 Block Diagram

Figure 9-1. μ DMA Block Diagram

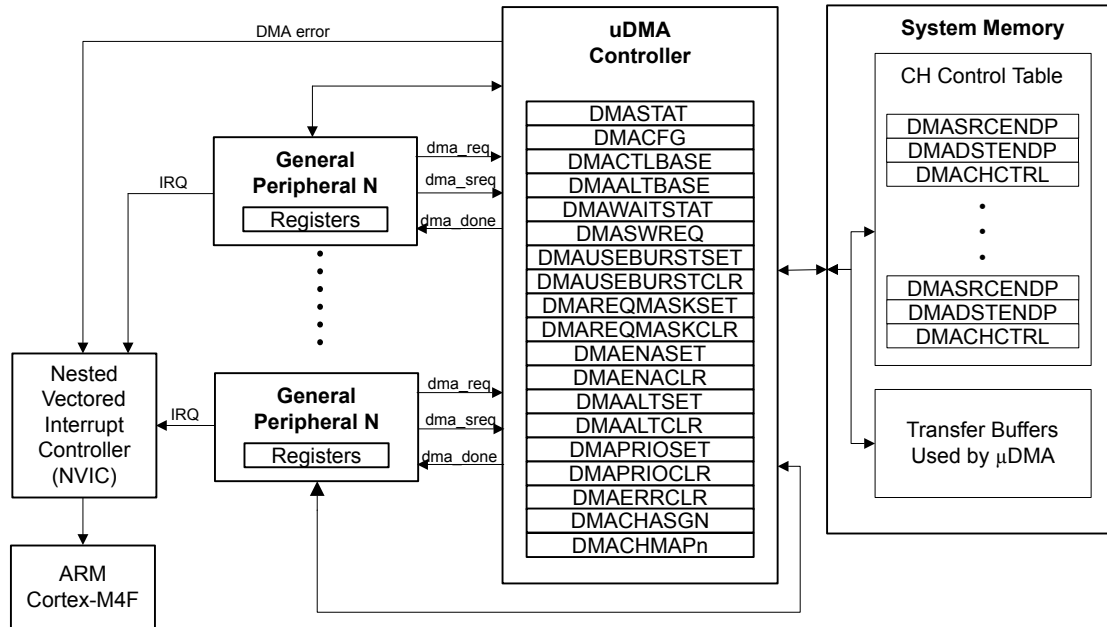

9.2 Functional Description

The μ DMA controller is a flexible and highly configurable DMA controller designed to work efficiently with the microcontroller's Cortex-M4F processor core. It supports multiple data sizes and address increment schemes, multiple levels of priority among DMA channels, and several transfer modes to allow for sophisticated programmed data transfers. The μ DMA controller's usage of the bus is always subordinate to the processor core, so it never holds up a bus transaction by the processor. Because the μ DMA controller is only using otherwise-idle bus cycles, the data transfer bandwidth it provides is essentially free, with no impact on the rest of the system. The bus architecture has been optimized to greatly enhance the ability of the processor core and the μ DMA controller to efficiently share the on-chip bus, thus improving performance. The optimizations include RAM striping and peripheral bus segmentation, which in many cases allow both the processor core and the μ DMA controller to access the bus and perform simultaneous data transfers.

Each peripheral function that is supported has a dedicated channel on the μ DMA controller that can be configured independently. The μ DMA controller implements a unique configuration method using channel control structures that are maintained in system memory by the processor. While simple transfer modes are supported, it is also possible to build up sophisticated "task" lists in memory that allow the μ DMA controller to perform arbitrary-sized transfers to and from arbitrary locations as part of a single transfer request. The μ DMA controller also supports the use of ping-pong buffering to accommodate constant streaming of data to or from a peripheral.

Each channel also has a configurable arbitration size. The arbitration size is the number of items that are transferred in a burst before the μ DMA controller re-arbitrates for channel priority. Using

the arbitration size, it is possible to control exactly how many items are transferred to or from a peripheral each time it makes a μ DMA service request.

9.2.1 Channel Assignments

Each DMA channel has up to nine possible assignments which are selected using the **DMA Channel Map Select n (DMACHMAPn)** registers with 4-bit assignment fields for each μ DMA channel.

Table 9-1 on page 688 shows the μ DMA channel mapping. The Enc. column shows the encoding for the respective **DMACHMAPn** bit field. Encodings 0x9-0xF are reserved. To support legacy software which uses the **DMA Channel Assignment (DMACHASGN)** register, Enc. 0 is equivalent to a **DMACHASGN** bit being clear, and Enc. 1 is equivalent to a **DMACHASGN** bit being set. If the **DMACHASGN** register is read, bit fields return 0 if the corresponding **DMACHMAPn** register field value are equal to 0, otherwise they return 1 if the corresponding **DMACHMAPn** register field values are not equal to 0. The Type indication in the table indicates if a particular peripheral uses a single request (S), burst request (B) or either (SB).

Note: Channels or encodings marked as reserved cannot be used for μ DMA transfers. Channels designated in the table as only "Software" are dedicated software channels. When only one software request is required in an application, dedicated software channels can be used. If multiple software requests in code are required, then peripheral channel software requests should be used for proper μ DMA completion acknowledgement.

Table 9-1. μ DMA Channel Assignments

Channel	Encoding																	
	0		1		2		3		4		5		6		7		8	
	Peripheral	Type	Peripheral	Type	Peripheral	Type	Peripheral	Type	Peripheral	Type	Peripheral	Type	Peripheral	Type	Peripheral	Type	Peripheral	Type
0	Reserved	-	UART2 RX	SB	Reserved	-	GPTimer 4A	B	Reserved	-	Reserved	-	I2C0 RX	SB B	Reserved	-	Reserved	-
1	Reserved	-	UART2 TX	SB	Reserved	-	GPTimer 4B	B	Reserved	-	Reserved	-	I2C0 TX	SB B	Reserved	-	Reserved	-
2	Reserved	-	GPTimer 3A	B	Reserved	-	Reserved	-	Reserved	-	Reserved	-	I2C1RX	SB B	Reserved	-	Reserved	-
3	Reserved	-	GPTimer 3B	B	Reserved	-	Software	S	Reserved	-	Reserved	-	I2C1 TX	SB B	Reserved	-	Reserved	-
4	Reserved	-	GPTimer 2A	B	Reserved	-	GPIO A	B	Reserved	-	SHAMD5 0 Cin	B	I2C2 RX	SB B	Reserved	-	Reserved	-
5	Reserved	-	GPTimer 2B	B	Reserved	-	GPIO B	B	Reserved	-	SHAMD5 0 Din	B	I2C2 TX	SB B	Reserved	-	Reserved	-
6	Reserved	-	GPTimer 2A	B	UART5 RX	SB	GPIO C	B	I2C0 RX	SB B	SHAMD5 0 Cout	B	Reserved	-	Reserved	-	Reserved	-
7	Reserved	-	GPTimer 2B	B	UART5 TX	SB	GPIO D	B	I2C0 TX	SB B	Reserved	-	Reserved	-	Reserved	-	Reserved	-
8	UART0 RX	SB	UART1 RX	SB	Reserved	-	GPTimer 5A	B	I2C1RX	SB B	Reserved	-	Reserved	-	Reserved	-	Reserved	-
9	UART0 TX	SB	UART1 TX	SB	Reserved	-	GPTimer 5B	B	I2C1 TX	SB B	Reserved	-	Reserved	-	Reserved	-	Reserved	-
10	SSI0 RX	SB	SSI1 RX	SB	UART6 RX	SB	Reserved	-	I2C2 RX	SB B	Reserved	-	Reserved	-	GPTimer 6A	B	Reserved	-

Table 9-1. μ DMA Channel Assignments (continued)

Channel	Encoding																	
	0		1		2		3		4		5		6		7		8	
	Peripheral	Type	Peripheral	Type	Peripheral	Type	Peripheral	Type	Peripheral	Type	Peripheral	Type	Peripheral	Type	Peripheral	Type	Peripheral	Type
11	SSI0 TX	SB	SSI1 TX	SB	UART6 TX	SB	Reserved	-	I2C2 TX	SB	Reserved	-	Reserved	-	GPTimer 6B	B	Reserved	-
12	Reserved	-	UART2 RX	SB	SSI2 RX	SB	Reserved	-	GPIO K	B	AES0 Cin	B	Reserved	-	GPTimer 7A	B	Reserved	-
13	Reserved	-	UART2 TX	SB	SSI2 TX	SB	Reserved	-	GPIO L	B	AES0 Cout	B	Reserved	-	GPTimer 7B	B	Reserved	-
14	ADC0 SS0	SB	GPTimer 2A	B	SSI3 RX	SB	GPIO E	B	GPIO M	B	AES0 Din	B	Reserved	-	Reserved	-	Reserved	-
15	ADC0 SS1	SB	GPTimer 2B	B	SSI3 TX	SB	GPIO F	B	GPIO N	B	AES0 Dout	B	Reserved	-	Reserved	-	Reserved	-
16	ADC0 SS2	SB	Reserved	-	UART3 RX	SB	Reserved	-	GPIO P	B	Reserved	-	Reserved	-	Reserved	-	Reserved	-
17	ADC0 SS3	SB	Reserved	-	UART3 TX	SB	Reserved	-	Reserved	-	Reserved	-	Reserved	-	Reserved	-	Reserved	-
18	GPTimer 0A	B	GPTimer 1A	B	UART4 RX	SB	GPIO B	B	I2C3 RX	SB	Reserved	-	Reserved	-	Reserved	-	Reserved	-
19	GPTimer 0B	B	GPTimer 1B	B	UART4 TX	SB	GPIO G	B	I2C3 TX	SB	Reserved	-	Reserved	-	Reserved	-	Reserved	-
20	GPTimer 1A	B	EPI 0 RX Software	B	UART7 RX	SB	GPIO H	B	I2C4 RX	SB	DES0 Cin	B	Reserved	-	Reserved	-	Reserved	-
21	GPTimer 1B	B	EPI 0 TX Software	B	UART7 TX	SB	GPIO J	B	I2C4 TX	SB	DES0 Din	B	Reserved	-	Reserved	-	Reserved	-
22	UART1 RX	SB	Software	B	Reserved	-	Software	B	I2C5 RX	SB	DES0 Dout	B	Reserved	-	Reserved	-	I2C8 RX	B
23	UART1 TX	SB	Software	B	Reserved	-	Software	B	I2C5 TX	SB	Reserved	-	Reserved	-	Reserved	-	I2C8 TX	B
24	SSI1 RX	SB	ADC1 SS0	SB	Reserved	-	Reserved	-	GPIO Q	B	Reserved	-	Reserved	-	Reserved	-	I2C9 RX	B
25	SSI1 TX	SB	ADC1 SS1	SB	Reserved	-	Reserved	-	Software		Reserved	-	Reserved	-	Reserved	-	I2C9 TX	B
26	Software	B	ADC1 SS2	SB	Reserved	-	Reserved	-	Software		Reserved	-	Reserved	-	Reserved	-	I2C6 RX	B
27	Software	B	ADC1 SS3	SB	Reserved	-	Reserved	-	Reserved	-	Reserved	-	Software	B	Reserved	-	I2C6 TX	B
28	Reserved	-	Reserved	-	Reserved	-	Reserved	-	Reserved	-	Reserved	-	Reserved	-	Reserved	-	I2C7 RX	B
29	Reserved	-	Reserved	-	Reserved	-	Reserved	-	Reserved	-	Reserved	-	Reserved	-	Reserved	-	I2C7 TX	B
30	Software	B	Software	B	Reserved	-	Software	B	Reserved	-	Reserved	-	Reserved	-	EPI0 RX	B	Software	B
31	Reserved	-	Reserved	-	Reserved	-	Reserved	B	Reserved	-	Reserved	-	Reserved	-	EPI0 TX	B	Reserved	-

9.2.2 Priority

The μ DMA controller assigns priority to each channel based on the channel number and the priority level bit for the channel. Channel number 0 has the highest priority and as the channel number increases, the priority of a channel decreases. Each channel has a priority level bit to provide two

levels of priority: default priority and high priority. If the priority level bit is set, then that channel has higher priority than all other channels at default priority. If multiple channels are set for high priority, then the channel number is used to determine relative priority among all the high priority channels.

The priority bit for a channel can be set using the **DMA Channel Priority Set (DMAPRIOSET)** register and cleared with the **DMA Channel Priority Clear (DMAPRIOCLR)** register.

Note: If one peripheral is mapped to two different channels, then the application should either use the default mapping for that peripheral or change the default mapping to another source. For example, if UART1 channels 8 and 9 are enabled for use, then even if channels 22 and 23 are disabled, they must be mapped to software or another peripheral (if available).

9.2.3 Arbitration Size

When a μ DMA channel requests a transfer, the μ DMA controller arbitrates among all the channels making a request and services the μ DMA channel with the highest priority. Once a transfer begins, it continues for a selectable number of transfers before re-arbitrating among the requesting channels again. The arbitration size can be configured for each channel, ranging from 1 to 1024 item transfers. After the μ DMA controller transfers the number of items specified by the arbitration size, it then checks among all the channels making a request and services the channel with the highest priority.

If a lower priority μ DMA channel uses a large arbitration size, the latency for higher priority channels is increased because the μ DMA controller completes the lower priority burst before checking for higher priority requests. Therefore, lower priority channels should not use a large arbitration size for best response on high priority channels.

The arbitration size can also be thought of as a burst size. It is the maximum number of items that are transferred at any one time in a burst. Here, the term arbitration refers to determination of μ DMA channel priority, not arbitration for the bus. When the μ DMA controller arbitrates for the bus, the processor always takes priority. Furthermore, the μ DMA controller is held off whenever the processor must perform a bus transaction on the same bus, even in the middle of a burst transfer.

9.2.4 Request Types

The μ DMA controller responds to two types of requests from a peripheral: single or burst. Each peripheral may support either or both types of requests. A single request means that the peripheral is ready to transfer one item, while a burst request means that the peripheral is ready to transfer multiple items.

The μ DMA controller responds differently depending on whether the peripheral is making a single request or a burst request. If both are asserted, and the μ DMA channel has been set up for a burst transfer, then the burst request takes precedence. See Table 9-2 on page 690, which shows how each peripheral supports the two request types.

Table 9-2. Request Type Support

Peripheral	Event that generates Single Request	Event that generates Burst Request
ADC	FIFO not empty	FIFO half full
EPI WFIFO	None	WFIFO Level (configurable)
EPI NBRFIFO	None	NBRFIFO Level (configurable)
General-Purpose Timer	None	Trigger event
GPIO	None	Trigger event
I ² C TX	TX Buffer Not Full	TX FIFO Level (configurable)
I ² C RX	RX Buffer Not Empty	RX FIFO Level (configurable)

Table 9-2. Request Type Support (continued)

Peripheral	Event that generates Single Request	Event that generates Burst Request
SSI TX	TX FIFO Not Full	TX FIFO Level (fixed at 4)
SSI RX	RX FIFO Not Empty	RX FIFO Level (fixed at 4)
UART TX	TX FIFO Not Full	TX FIFO Level (configurable)
UART RX	RX FIFO Not Empty	RX FIFO Level (configurable)
SHA/MD5	None	Context In DMA request (SHA/MD5 0 Cin) Context Out DMA request (SHA/MD5 0 Cout) Data In DMA request (SHA/MD5 0 Din)
AES	None	Context In DMA request (AES0 Cin) Context Out DMA request (AES0 Cout) Data In DMA request (AES0 Din) Data Out DMA request (AES0 Dout)
DES	None	Context In DMA request (DES0 Cin) Data In DMA request (DES0 Din) Data Out DMA request (DES0 Dout)

9.2.4.1 Single Request

When a single request is detected, and not a burst request, the μ DMA controller transfers one item and then stops to wait for another request.

9.2.4.2 Burst Request

When a burst request is detected, the μ DMA controller transfers the number of items that is the lesser of the arbitration size or the number of items remaining in the transfer. Therefore, the arbitration size should be the same as the number of data items that the peripheral can accommodate when making a burst request. For example, the UART generates a burst request based on the FIFO trigger level. In this case, the arbitration size should be set to the amount of data that the FIFO can transfer when the trigger level is reached. A burst transfer runs to completion once it is started, and cannot be interrupted, even by a higher priority channel. Burst transfers complete in a shorter time than the same number of non-burst transfers.

It may be desirable to use only burst transfers and not allow single transfers. For example, perhaps the nature of the data is such that it only makes sense when transferred together as a single unit rather than one piece at a time. The single request can be disabled by using the **DMA Channel Useburst Set (DMAUSEBURSTSET)** register. By setting the bit for a channel in this register, the μ DMA controller only responds to burst requests for that channel.

9.2.5 Channel Configuration

The μ DMA controller uses an area of system memory to store a set of channel control structures in a table. The control table may have one or two entries for each μ DMA channel. Each entry in the table structure contains source and destination pointers, transfer size, and transfer mode. The control table can be located anywhere in system memory, but it must be contiguous and aligned on a 1024-byte boundary.

Table 9-3 on page 692 shows the layout in memory of the channel control table. Each channel may have one or two control structures in the control table: a primary control structure and an optional alternate control structure. The table is organized so that all of the primary entries are in the first half of the table, and all the alternate structures are in the second half of the table. The primary entry is used for simple transfer modes where transfers can be reconfigured and restarted after each

transfer is complete. In this case, the alternate control structures are not used and therefore only the first half of the table must be allocated in memory; the second half of the control table is not necessary, and that memory can be used for something else. If a more complex transfer mode is used such as ping-pong or scatter-gather, then the alternate control structure is also used and memory space should be allocated for the entire table.

Any unused memory in the control table may be used by the application. This includes the control structures for any channels that are unused by the application as well as the unused control word for each channel.

Table 9-3. Control Structure Memory Map

Offset	Channel
0x0	0, Primary
0x10	1, Primary
...	...
0x1F0	31, Primary
0x200	0, Alternate
0x210	1, Alternate
...	...
0x3F0	31, Alternate

Table 9-4 shows an individual control structure entry in the control table. Each entry is aligned on a 16-byte boundary. The entry contains four long words: the source end pointer, the destination end pointer, the control word, and an unused entry. The end pointers point to the ending address of the transfer and are inclusive. If the source or destination is non-incrementing (as for a peripheral register), then the pointer should point to the transfer address.

Table 9-4. Channel Control Structure

Offset	Description
0x000	Source End Pointer
0x004	Destination End Pointer
0x008	Control Word
0x00C	Unused

The control word contains the following fields:

- Source and destination data sizes
- Source and destination address increment size
- Number of transfers before bus arbitration
- Total number of items to transfer
- Useburst flag
- Transfer mode

The control word and each field are described in detail in “ μ DMA Channel Control Structure” on page 710. The μ DMA controller updates the transfer size and transfer mode fields as the transfer is performed. At the end of a transfer, the transfer size indicates 0, and the transfer

mode indicates "stopped." Because the control word is modified by the μ DMA controller, it must be reconfigured before each new transfer. The source and destination end pointers are not modified, so they can be left unchanged if the source or destination addresses remain the same.

Prior to starting a transfer, a μ DMA channel must be enabled by setting the appropriate bit in the **DMA Channel Enable Set (DMAENASET)** register. A channel can be disabled by setting the channel bit in the **DMA Channel Enable Clear (DMAENACLR)** register. At the end of a complete μ DMA transfer, the controller automatically disables the channel.

9.2.6 Transfer Modes

The μ DMA controller supports several transfer modes. Two of the modes support simple one-time transfers. Several complex modes support a continuous flow of data.

9.2.6.1 Stop Mode

While Stop is not actually a transfer mode, it is a valid value for the mode field of the control word. When the mode field has this value, the μ DMA controller does not perform any transfers and disables the channel if it is enabled. At the end of a transfer, the μ DMA controller updates the control word to set the mode to Stop.

9.2.6.2 Basic Mode

In Basic mode, the μ DMA controller performs transfers as long as there are more items to transfer, and a transfer request is present. This mode is used with peripherals that assert a μ DMA request signal whenever the peripheral is ready for a data transfer. Basic mode should not be used in any situation where the request is momentary even though the entire transfer should be completed. For example, a software-initiated transfer creates a momentary request, and in Basic mode, only the number of transfers specified by the `ARBSIZE` field in the **DMA Channel Control Word (DMACHCTL)** register is transferred on a software request, even if there is more data to transfer.

When all of the items have been transferred using Basic mode, the μ DMA controller sets the mode for that channel to Stop.

BASIC mode can be programmed to ignore when `XFERSIZE` reaches 0x000 and continue copying on request until the channel is stopped manually. If the `NXTUSEBURST` bit in the **uDMA Channel Control Word (DMACHCTL)** register is set while in BASIC mode and the `XFERSIZE` reaches 0x000 and is not written back, transfers continue until the request is deasserted by the peripheral.

9.2.6.3 Auto Mode

Auto mode is similar to Basic mode, except that once a transfer request is received, the transfer runs to completion, even if the μ DMA request is removed. This mode is suitable for software-triggered transfers. Generally, Auto mode is not used with a peripheral.

When all the items have been transferred using Auto mode, the μ DMA controller sets the mode for that channel to Stop.

9.2.6.4 Ping-Pong

Ping-Pong mode is used to support a continuous data flow to or from a peripheral. To use Ping-Pong mode, both the primary and alternate data structures must be implemented. Both structures are set up by the processor for data transfer between memory and a peripheral. The transfer is started using the primary control structure. When the transfer using the primary control structure is complete, the μ DMA controller reads the alternate control structure for that channel to continue the transfer. Each time this happens, an interrupt is generated, and the processor can reload the control structure for the just-completed transfer. Data flow can continue indefinitely this way, using the primary and

alternate control structures to switch back and forth between buffers as the data flows to or from the peripheral.

Refer to Figure 9-2 on page 694 for an example showing operation in Ping-Pong mode.

Figure 9-2. Example of Ping-Pong μ DMA Transaction

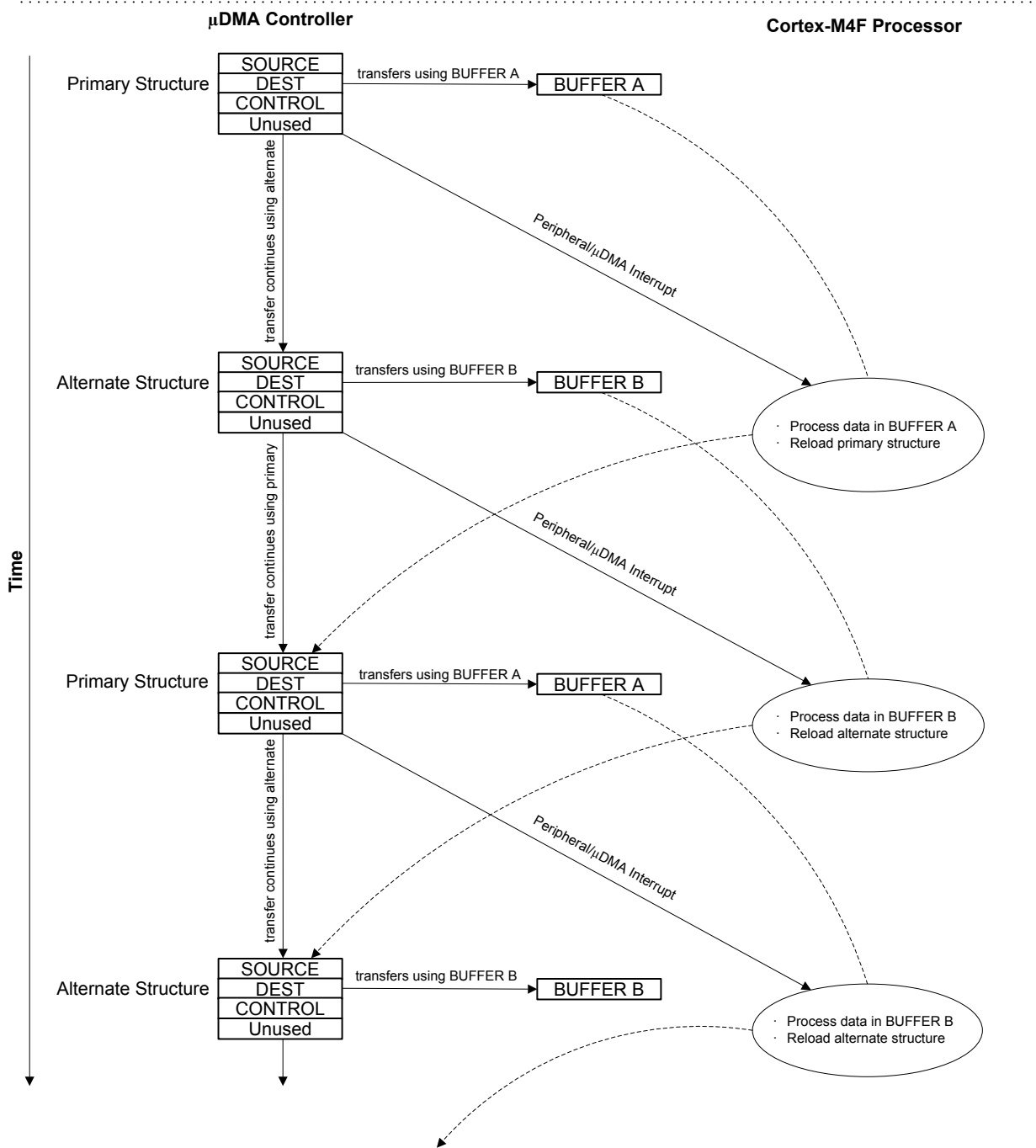

9.2.6.5 Memory Scatter-Gather

Memory Scatter-Gather mode is a complex mode used when data must be transferred to or from varied locations in memory instead of a set of contiguous locations in a memory buffer. For example, a gather μ DMA operation could be used to selectively read the payload of several stored packets of a communication protocol and store them together in sequence in a memory buffer.

In Memory Scatter-Gather mode, the primary control structure is used to program the alternate control structure from a table in memory. The table is set up by the processor software and contains a list of control structures, each containing the source and destination end pointers, and the control word for a specific transfer. The mode of each control word must be set to Scatter-Gather mode. Each entry in the table is copied in turn to the alternate structure where it is then executed. The μ DMA controller alternates between using the primary control structure to copy the next transfer instruction from the list and then executing the new transfer instruction. The end of the list is marked by programming the control word for the last entry to use Auto transfer mode. Once the last transfer is performed using Auto mode, the μ DMA controller stops. A completion interrupt is generated only after the last transfer. It is possible to loop the list by having the last entry copy the primary control structure to point back to the beginning of the list (or to a new list). It is also possible to trigger a set of other channels to perform a transfer, either directly, by programming a write to the software trigger for another channel, or indirectly, by causing a peripheral action that results in a μ DMA request.

By programming the μ DMA controller using this method, a set of up to 256 arbitrary transfers can be performed based on a single μ DMA request.

Refer to Figure 9-3 on page 696 and Figure 9-4 on page 697, which show an example of operation in Memory Scatter-Gather mode. This example shows a *gather* operation, where data in three separate buffers in memory is copied together into one buffer. Figure 9-3 on page 696 shows how the application sets up a μ DMA task list in memory that is used by the controller to perform three sets of copy operations from different locations in memory. The primary control structure for the channel that is used for the operation is configured to copy from the task list to the alternate control structure.

Figure 9-4 on page 697 shows the sequence as the μ DMA controller performs the three sets of copy operations. First, using the primary control structure, the μ DMA controller loads the alternate control structure with task A. It then performs the copy operation specified by task A, copying the data from the source buffer A to the destination buffer. Next, the μ DMA controller again uses the primary control structure to load task B into the alternate control structure, and then performs the B operation with the alternate control structure. The process is repeated for task C.

Figure 9-3. Memory Scatter-Gather, Setup and Configuration

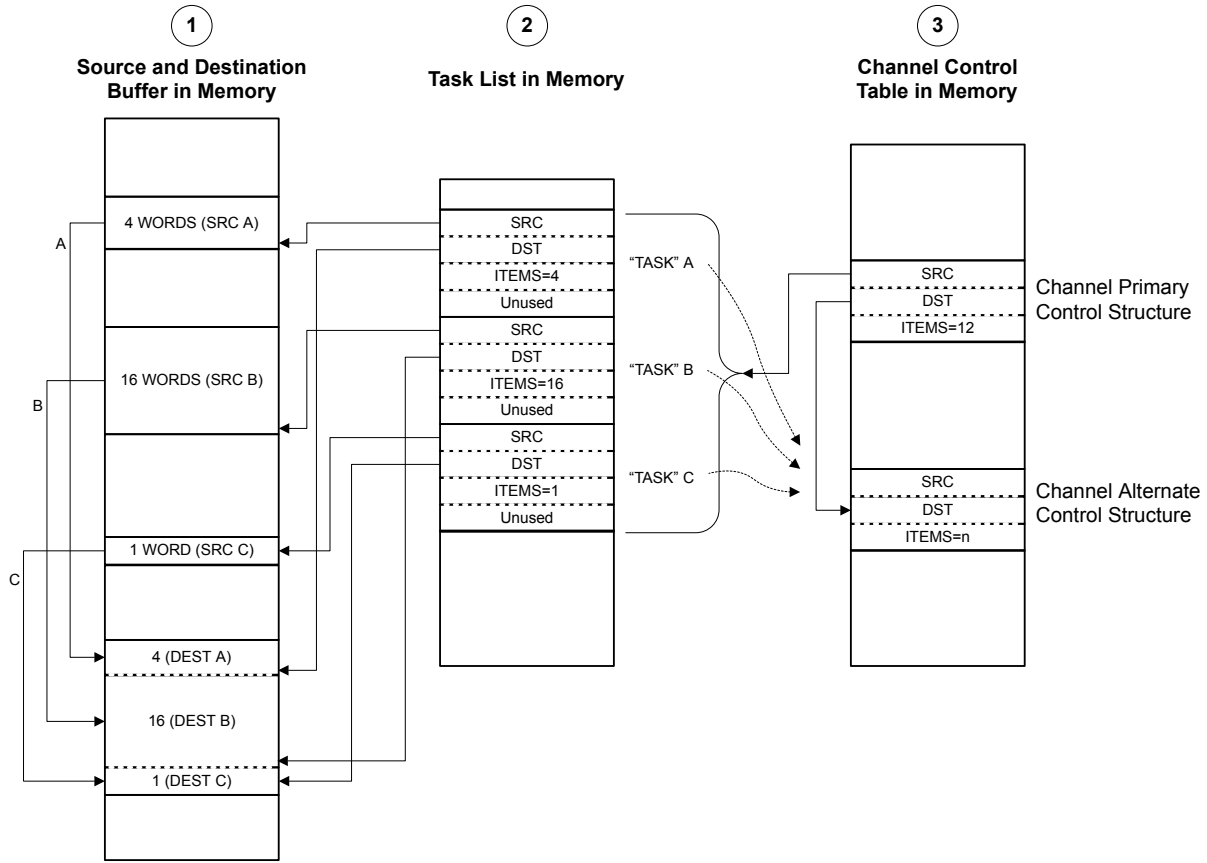

NOTES:

1. Application has a need to copy data items from three separate locations in memory into one combined buffer.
2. Application sets up μ DMA "task list" in memory, which contains the pointers and control configuration for three μ DMA copy "tasks."
3. Application sets up the channel primary control structure to copy each task configuration, one at a time, to the alternate control structure, where it is executed by the μ DMA controller.
4. The SRC and DST pointers in the task list must point to the last location in the corresponding buffer.

Figure 9-4. Memory Scatter-Gather, μ DMA Copy Sequence

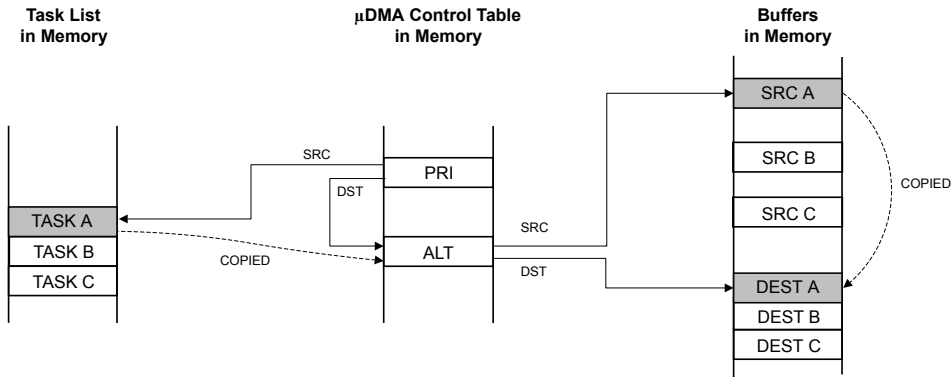

Using the channel's primary control structure, the μ DMA controller copies task A configuration to the channel's alternate control structure.

Then, using the channel's alternate control structure, the μ DMA controller copies data from the source buffer A to the destination buffer.

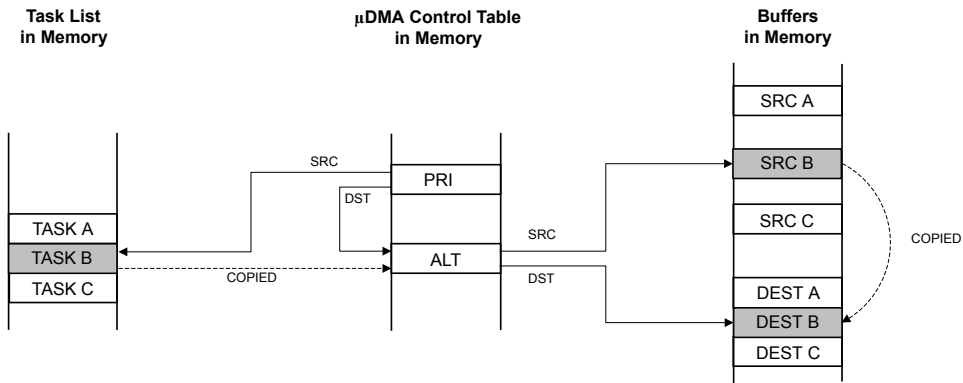

Using the channel's primary control structure, the μ DMA controller copies task B configuration to the channel's alternate control structure.

Then, using the channel's alternate control structure, the μ DMA controller copies data from the source buffer B to the destination buffer.

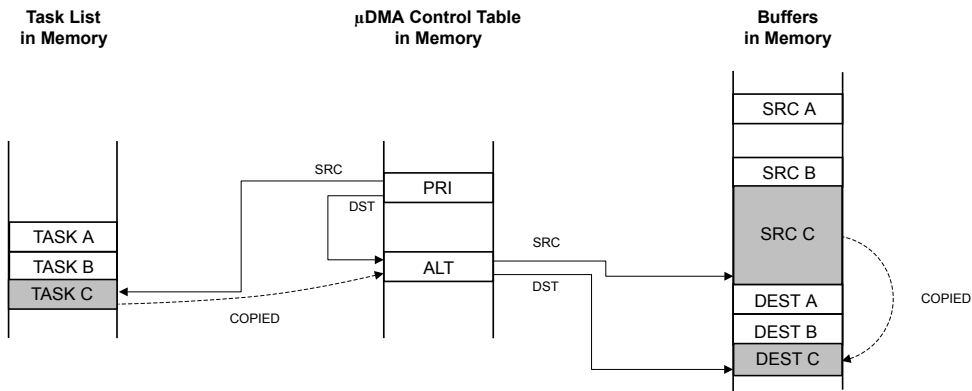

Using the channel's primary control structure, the μ DMA controller copies task C configuration to the channel's alternate control structure.

Then, using the channel's alternate control structure, the μ DMA controller copies data from the source buffer C to the destination buffer.

9.2.6.6 Peripheral Scatter-Gather

Peripheral Scatter-Gather mode is very similar to Memory Scatter-Gather, except that the transfers are controlled by a peripheral making a μ DMA request. Upon detecting a request from the peripheral, the μ DMA controller uses the primary control structure to copy one entry from the list to the alternate control structure and then performs the transfer. At the end of this transfer, the primary control structure will copy the next task to the alternate control structure. If the next task is a memory-to-memory transfer, execution will start immediately and run to completion; if the next task is a peripheral-type transfer, the μ DMA will wait for a peripheral request to begin.

By using this method, the μ DMA controller can transfer data to or from a peripheral from a set of arbitrary locations whenever the peripheral is ready to transfer data.

Refer to Figure 9-5 on page 699 and Figure 9-6 on page 700, which show an example of operation in Peripheral Scatter-Gather mode. This example shows a gather operation, where data from three separate buffers in memory is copied to a single peripheral data register. Figure 9-5 on page 699 shows how the application sets up a μ DMA task list in memory that is used by the controller to perform three sets of copy operations from different locations in memory. The primary control structure for the channel that is used for the operation is configured to copy from the task list to the alternate control structure.

Figure 9-6 on page 700 shows the sequence as the μ DMA controller performs the three sets of copy operations. First, using the primary control structure, the μ DMA controller loads the alternate control structure with task A. It then performs the copy operation specified by task A, copying the data from the source buffer A to the peripheral data register. Next, the μ DMA controller again uses the primary control structure to load task B into the alternate control structure, and then performs the B operation with the alternate control structure. The process is repeated for task C.

Figure 9-5. Peripheral Scatter-Gather, Setup and Configuration

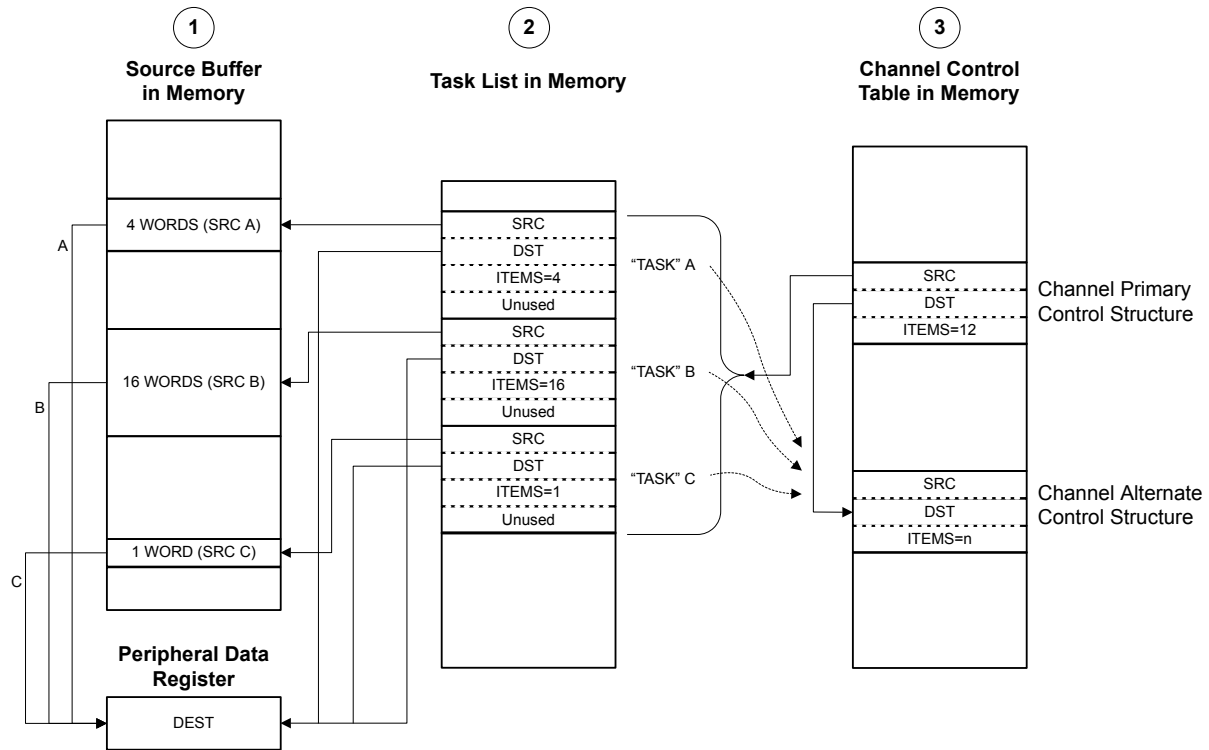

NOTES:

1. Application has a need to copy data items from three separate locations in memory into a peripheral data register.
2. Application sets up μ DMA "task list" in memory, which contains the pointers and control configuration for three μ DMA copy "tasks."
3. Application sets up the channel primary control structure to copy each task configuration, one at a time, to the alternate control structure, where it is executed by the μ DMA controller.

Figure 9-6. Peripheral Scatter-Gather, μ DMA Copy Sequence



Using the channel's primary control structure, the μ DMA controller copies task A configuration to the channel's alternate control structure.

Then, using the channel's alternate control structure, the μ DMA controller copies data from the source buffer A to the peripheral data register.



Using the channel's primary control structure, the μ DMA controller copies task B configuration to the channel's alternate control structure.

Then, using the channel's alternate control structure, the μ DMA controller copies data from the source buffer B to the peripheral data register.



Using the channel's primary control structure, the μ DMA controller copies task C configuration to the channel's alternate control structure.

Then, using the channel's alternate control structure, the μ DMA controller copies data from the source buffer C to the peripheral data register.

9.2.7 Transfer Size and Increment

The μ DMA controller supports transfer data sizes of 8, 16, or 32 bits. The source and destination data size must be the same for any given transfer. The source and destination address can be auto-incremented by bytes, half-words, or words, or can be set to no increment. The source and destination address increment values can be set independently, and it is not necessary for the address increment to match the data size as long as the increment is the same or larger than the data size. For example, it is possible to perform a transfer using 8-bit data size, but using an address increment of full words (4 bytes). The data to be transferred must be aligned in memory according to the data size (8, 16, or 32 bits).

Table 9-5 shows the configuration to read from a peripheral that supplies 8-bit data.

Table 9-5. μ DMA Read Example: 8-Bit Peripheral

Field	Configuration
Source data size	8 bits
Destination data size	8 bits
Source address increment	No increment
Destination address increment	Byte
Source end pointer	Peripheral read FIFO register
Destination end pointer	End of the data buffer in memory

9.2.8 Peripheral Interface

There are three main classes of μ DMA-connected peripherals:

- Peripherals with FIFOs serviced by the μ DMA to transmit or receive data.
- Peripherals that provide trigger inputs to the μ DMA

9.2.8.1 FIFO Peripherals

FIFO peripherals contain a FIFO of data to be sent and a FIFO of data that has been received. The μ DMA controller is used to transfer data between these FIFOs and system memory. For example, when a UART FIFO contains one or more entries, a single transfer request is sent to the μ DMA for processing. If this request has not been processed and the UART FIFO reaches the interrupt FIFO level set in the **UART Interrupt FIFO Level Select (UARTIFLS)** register, another interrupt is sent to the μ DMA which is higher priority than the single-transfer request. In this instance, an **ARBSIZ** transfer is performed as configured in the **DMACHCTL** register. After the transfer is complete, the DMA sends a receive or transmit complete interrupt to the **UART Raw Interrupt Status (UARTRIS)** register.

If the FIFO peripheral's **SETn** bit is set in the **DMA Channel Useburst Set (DMAUSEBURSTSET)** register, then the μ DMA will only perform transfers defined by the **ARBSIZ** bit field in the **DMACHCTL** register for better bus utilization. For peripherals that tend to transmit and receive in bursts, such as the UART, we recommend against the use of this configuration since it could cause the tail end of transmissions to stick in the FIFO.

9.2.8.2 Trigger Peripherals

Certain peripherals, such as the general purpose timer, trigger an interrupt to the μ DMA controller when a programmed event occurs. When a trigger event occurs, the μ DMA executes a transfer defined by the **ARBSIZ** bit field in the **DMACHCTL** register. If only a single transfer is needed for a μ DMA trigger, then the **ARBSIZ** field is set to 0x1.

If the trigger peripheral generates another μ DMA request while the prior one is being serviced and that particular channel is the highest priority asserted channel, the second request will be processed as soon as the handling of the first is complete. If two additional trigger peripheral μ DMA requests are generated prior to the completion of the first, the third request is lost.

9.2.9 Software Request

A transfer is initiated by software by first configuring and enabling the transfer, and then issuing a software request using the **DMA Channel Software Request (DMASWREQ)** register. For software-based transfers, the Auto transfer mode should be used.

It is possible to initiate a transfer on any available software channel using the **DMASWREQ** register. If a request is initiated by software using a peripheral μ DMA channel, then the completion interrupt occurs on the interrupt vector for the peripheral instead of the software interrupt vector. Any peripheral channel may be used for software requests as long as the corresponding peripheral is not using μ DMA for data transfer.

Note: Channels designated in the table as only "Software" are dedicated software channels. When only one software request is required in an application, dedicated software channels can be used. If multiple software requests in code are required, then peripheral channel software requests should be used for proper μ DMA completion acknowledgement.

9.2.10 Interrupts and Errors

Depending on the peripheral, the μ DMA can indicate transfer completion at the end of an entire transfer or when a FIFO or buffer reaches a certain level (see Table 9-2 on page 690 and the individual peripheral chapters). When a μ DMA transfer is complete, a `dma_done` signal is sent to the peripheral that initiated the μ DMA event. Interrupts can be enabled within the peripheral to trigger on μ DMA transfer completion. Please refer to the individual peripheral chapters for more information on peripheral μ DMA interrupts. If the transfer uses the software μ DMA channel, then the completion interrupt occurs on the dedicated software μ DMA interrupt vector (see Table 9-6 on page 702).

If the μ DMA controller encounters a bus or memory protection error as it attempts to perform a data transfer, it disables the μ DMA channel that caused the error and generates an interrupt on the μ DMA error interrupt vector. The processor can read the **DMA Bus Error Clear (DMAERRCLR)** register to determine if an error is pending. The `ERRCLR` bit is set if an error occurred. The error can be cleared by writing a 1 to the `ERRCLR` bit.

Table 9-6 shows the dedicated interrupt assignments for the μ DMA controller.

Table 9-6. μ DMA Interrupt Assignments

Interrupt	Assignment
44	μ DMA Software Channel Transfer
45	μ DMA Error

9.3 Initialization and Configuration

9.3.1 Module Initialization

Before the μ DMA controller can be used, it must be enabled in the System Control block and in the peripheral. The location of the channel control structure must also be programmed.

The following steps should be performed one time during system initialization:

1. Enable the μ DMA clock using the **RCGCDMA** register (see page 392).

2. Enable the μ DMA controller by setting the `MASTEREN` bit of the **DMA Configuration (DMACFG)** register.
3. Program the location of the channel control table by writing the base address of the table to the **DMA Channel Control Base Pointer (DMACTLBASE)** register. The base address must be aligned on a 1024-byte boundary.

9.3.2 Configuring a Memory-to-Memory Transfer

μ DMA channel 30 is dedicated for software-initiated transfers. However, any channel can be used for software-initiated, memory-to-memory transfer if the associated peripheral is not being used.

9.3.2.1 Configure the Channel Attributes

First, configure the channel attributes:

1. Program bit 30 of the **DMA Channel Priority Set (DMAPRIOSET)** or **DMA Channel Priority Clear (DMAPRIOCLR)** registers to set the channel to High priority or Default priority.
2. Set bit 30 of the **DMA Channel Primary Alternate Clear (DMAALTCLR)** register to select the primary channel control structure for this transfer.
3. Set bit 30 of the **DMA Channel Useburst Clear (DMAUSEBURSTCLR)** register to allow the μ DMA controller to respond to single and burst requests.
4. Set bit 30 of the **DMA Channel Request Mask Clear (DMAREQMASKCLR)** register to allow the μ DMA controller to recognize requests for this channel.

9.3.2.2 Configure the Channel Control Structure

Now the channel control structure must be configured.

This example transfers 256 words from one memory buffer to another. Channel 30 is used for a software transfer, and the control structure for channel 30 is at offset 0x1E0 of the channel control table. The channel control structure for channel 30 is located at the offsets shown in Table 9-7.

Table 9-7. Channel Control Structure Offsets for Channel 30

Offset	Description
Control Table Base + 0x1E0	Channel 30 Source End Pointer
Control Table Base + 0x1E4	Channel 30 Destination End Pointer
Control Table Base + 0x1E8	Channel 30 Control Word

Configure the Source and Destination

The source and destination end pointers must be set to the last address for the transfer (inclusive).

1. Program the source end pointer at offset 0x1E0 to the address of the source buffer + 0x3FC.
2. Program the destination end pointer at offset 0x1E4 to the address of the destination buffer + 0x3FC.

The control word at offset 0x1E8 must be programmed according to Table 9-8.

Table 9-8. Channel Control Word Configuration for Memory Transfer Example

Field in DMACHCTL	Bits	Value	Description
DSTINC	31:30	2	32-bit destination address increment
DSTSIZE	29:28	2	32-bit destination data size
SRCINC	27:26	2	32-bit source address increment
SRCSIZE	25:24	2	32-bit source data size
reserved	23:22	0	Reserved
DSTPROTO ^a	21	0	Privileged access protection for destination data writes
reserved	20:19	0	Reserved
SRCPROTO ^a	18	0	Privileged access protection for source data reads
ARBSIZE	17:14	3	Arbitrates after 8 transfers
XFERSIZE	13:4	255	Transfer 256 items
NXTUSEBURST	3	0	N/A for this transfer type
XFERMODE	2:0	2	Use Auto-request transfer mode

a. The value of this bit must be 1 (privileged) for AES, DES, or SHA accesses.

Configure Peripheral Interrupts

For memory-to-memory transfers, the peripheral involved must be configured to generate an interrupt when the μ DMA has completed its transfer. Upon completion, the μ DMA will send a `dma_done` signal to the peripheral.

9.3.2.3 Start the Transfer

Now the channel is configured and is ready to start.

1. Enable the channel by setting bit 30 of the **DMA Channel Enable Set (DMAENASET)** register.
2. Issue a transfer request by setting bit 30 of the **DMA Channel Software Request (DMASWREQ)** register.

The μ DMA transfer begins. If the interrupt is enabled, then the processor is notified by interrupt when the transfer is complete. If needed, the status can be checked by reading bit 30 of the **DMAENASET** register. This bit is automatically cleared when the transfer is complete. The status can also be checked by reading the `XFERMODE` field of the channel control word at offset 0x1E8. This field is automatically cleared at the end of the transfer.

9.3.3 Configuring a Peripheral for Simple Transmit

This example configures the μ DMA controller to transmit a buffer of data to a peripheral. The peripheral has a transmit FIFO with a trigger level of 4. The example peripheral uses μ DMA channel 7.

9.3.3.1 Configure the Channel Attributes

First, configure the channel attributes:

1. Configure bit 7 of the **DMA Channel Priority Set (DMAPRIOSET)** or **DMA Channel Priority Clear (DMAPRIOCLR)** registers to set the channel to High priority or Default priority.

2. Set bit 7 of the **DMA Channel Primary Alternate Clear (DMAALTCLR)** register to select the primary channel control structure for this transfer.
3. Set bit 7 of the **DMA Channel Useburst Clear (DMAUSEBURSTCLR)** register to allow the μ DMA controller to respond to single and burst requests.
4. Set bit 7 of the **DMA Channel Request Mask Clear (DMAREQMASKCLR)** register to allow the μ DMA controller to recognize requests for this channel.

9.3.3.2 Configure the Channel Control Structure

This example transfers 64 bytes from a memory buffer to the peripheral's transmit FIFO register using μ DMA channel 7. The control structure for channel 7 is at offset 0x070 of the channel control table. The channel control structure for channel 7 is located at the offsets shown in Table 9-9.

Table 9-9. Channel Control Structure Offsets for Channel 7

Offset	Description
Control Table Base + 0x070	Channel 7 Source End Pointer
Control Table Base + 0x074	Channel 7 Destination End Pointer
Control Table Base + 0x078	Channel 7 Control Word

Configure the Source and Destination

The source and destination end pointers must be set to the last address for the transfer (inclusive). Because the peripheral pointer does not change, it simply points to the peripheral's data register.

1. Program the source end pointer at offset 0x070 to the address of the source buffer + 0x3F.
2. Program the destination end pointer at offset 0x074 to the address of the peripheral's transmit FIFO register.

The control word at offset 0x078 must be programmed according to Table 9-10.

Table 9-10. Channel Control Word Configuration for Peripheral Transmit Example

Field in DMACHCTL	Bits	Value	Description
DSTINC	31:30	3	Destination address does not increment
DSTSIZE	29:28	0	8-bit destination data size
SRCINC	27:26	0	8-bit source address increment
SRCSIZE	25:24	0	8-bit source data size
reserved	23:22	0	Reserved
DSTPROT0 ^a	21	0	Privileged access protection for destination data writes
reserved	20:19	0	Reserved
SRCPROT0 ^a	18	0	Privileged access protection for source data reads
ARBSIZE	17:14	2	Arbitrates after 4 transfers
XFERSIZE	13:4	63	Transfer 64 items
NXTUSEBURST	3	0	N/A for this transfer type
XFERMODE	2:0	1	Use Basic transfer mode

a. The value of this bit must be 1 (privileged) for AES, DES, or SHA accesses.

Note: In this example, it is not important if the peripheral makes a single request or a burst request. Because the peripheral has a FIFO that triggers at a level of 4, the arbitration size is set to 4. If the peripheral does make a burst request, then 4 bytes are transferred, which is what the FIFO can accommodate. If the peripheral makes a single request (if there is any space in the FIFO), then one byte is transferred at a time. If it is important to the application that transfers only be made in bursts, then the Channel Useburst `SET[7]` bit should be set in the **DMA Channel Useburst Set (DMAUSEBURSTSET)** register.

9.3.3.3 Start the Transfer

Now the channel is configured and is ready to start.

1. Enable the channel by setting bit 7 of the **DMA Channel Enable Set (DMAENASET)** register.

The μ DMA controller is now configured for transfer on channel 7. The controller makes transfers to the peripheral whenever the peripheral asserts a μ DMA request. The transfers continue until the entire buffer of 64 bytes has been transferred. When that happens, the μ DMA controller disables the channel and sets the `XFERMODE` field of the channel control word to 0 (Stopped). The status of the transfer can be checked by reading bit 7 of the **DMA Channel Enable Set (DMAENASET)** register. This bit is automatically cleared when the transfer is complete. The status can also be checked by reading the `XFERMODE` field of the channel control word at offset 0x078. This field is automatically cleared at the end of the transfer.

If peripheral interrupts are enabled, then the peripheral generates an interrupt when the entire transfer is complete.

9.3.4 Configuring a Peripheral for Ping-Pong Receive

This example configures the μ DMA controller to continuously receive 8-bit data from a peripheral into a pair of 64-byte buffers. The peripheral has a receive FIFO with a trigger level of 8. The example peripheral uses μ DMA channel 8.

9.3.4.1 Configure the Channel Attributes

First, configure the channel attributes:

1. Configure bit 8 of the **DMA Channel Priority Set (DMAPRIOSET)** or **DMA Channel Priority Clear (DMAPRIOCLR)** registers to set the channel to High priority or Default priority.
2. Set bit 8 of the **DMA Channel Primary Alternate Clear (DMAALTCLR)** register to select the primary channel control structure for this transfer.
3. Set bit 8 of the **DMA Channel Useburst Clear (DMAUSEBURSTCLR)** register to allow the μ DMA controller to respond to single and burst requests.
4. Set bit 8 of the **DMA Channel Request Mask Clear (DMAREQMASKCLR)** register to allow the μ DMA controller to recognize requests for this channel.

9.3.4.2 Configure the Channel Control Structure

This example transfers bytes from the peripheral's receive FIFO register into two memory buffers of 64 bytes each. As data is received, when one buffer is full, the μ DMA controller switches to use the other.

To use Ping-Pong buffering, both primary and alternate channel control structures must be used. The primary control structure for channel 8 is at offset 0x080 of the channel control table, and the

alternate channel control structure is at offset 0x280. The channel control structures for channel 8 are located at the offsets shown in Table 9-11.

Table 9-11. Primary and Alternate Channel Control Structure Offsets for Channel 8

Offset	Description
Control Table Base + 0x080	Channel 8 Primary Source End Pointer
Control Table Base + 0x084	Channel 8 Primary Destination End Pointer
Control Table Base + 0x088	Channel 8 Primary Control Word
Control Table Base + 0x280	Channel 8 Alternate Source End Pointer
Control Table Base + 0x284	Channel 8 Alternate Destination End Pointer
Control Table Base + 0x288	Channel 8 Alternate Control Word

Configure the Source and Destination

The source and destination end pointers must be set to the last address for the transfer (inclusive). Because the peripheral pointer does not change, it simply points to the peripheral's data register. Both the primary and alternate sets of pointers must be configured.

1. Program the primary source end pointer at offset 0x080 to the address of the peripheral's receive buffer.
2. Program the primary destination end pointer at offset 0x084 to the address of ping-pong buffer A + 0x3F.
3. Program the alternate source end pointer at offset 0x280 to the address of the peripheral's receive buffer.
4. Program the alternate destination end pointer at offset 0x284 to the address of ping-pong buffer B + 0x3F.

The primary control word at offset 0x088 and the alternate control word at offset 0x288 are initially programmed the same way.

1. Program the primary channel control word at offset 0x088 according to Table 9-12.
2. Program the alternate channel control word at offset 0x288 according to Table 9-12.

Table 9-12. Channel Control Word Configuration for Peripheral Ping-Pong Receive Example

Field in DMACHCTL	Bits	Value	Description
DSTINC	31:30	0	8-bit destination address increment
DSTSIZE	29:28	0	8-bit destination data size
SRCINC	27:26	3	Source address does not increment
SRCSIZE	25:24	0	8-bit source data size
reserved	23:22	0	Reserved
DSTPROT0	21	0	Privileged access protection for destination data writes
reserved	20:19	0	Reserved
SRCPROT0	18	0	Privileged access protection for source data reads
ARBSIZE	17:14	3	Arbitrates after 8 transfers

Table 9-12. Channel Control Word Configuration for Peripheral Ping-Pong Receive Example (continued)

Field in DMACHCTL	Bits	Value	Description
XFERSIZE	13:4	63	Transfer 64 items
NXTUSEBURST	3	0	N/A for this transfer type
XFERMODE	2:0	3	Use Ping-Pong transfer mode

Note: In this example, it is not important if the peripheral makes a single request or a burst request. Because the peripheral has a FIFO that triggers at a level of 8, the arbitration size is set to 8. If the peripheral does make a burst request, then 8 bytes are transferred, which is what the FIFO can accommodate. If the peripheral makes a single request (if there is any data in the FIFO), then one byte is transferred at a time. If it is important to the application that transfers only be made in bursts, then the Channel Useburst `SET[8]` bit should be set in the **DMA Channel Useburst Set (DMAUSEBURSTSET)** register.

9.3.4.3 Configure the Peripheral Interrupt

An interrupt handler should be configured when using μ DMA Ping-Pong mode, it is best to use an interrupt handler. However, the Ping-Pong mode can be configured without interrupts by polling. The interrupt handler is triggered after each buffer is complete.

1. Configure and enable an interrupt handler for the peripheral.

9.3.4.4 Enable the μ DMA Channel

Now the channel is configured and is ready to start.

1. Enable the channel by setting bit 8 of the **DMA Channel Enable Set (DMAENASET)** register.

9.3.4.5 Process Interrupts

The μ DMA controller is now configured and enabled for transfer on channel 8. When the peripheral asserts the μ DMA request signal, the μ DMA controller makes transfers into buffer A using the primary channel control structure. When the primary transfer to buffer A is complete, it switches to the alternate channel control structure and makes transfers into buffer B. At the same time, the primary channel control word mode field is configured to indicate Stopped, and an interrupt is generated in the peripheral's raw interrupt status register.

When an interrupt is triggered, the interrupt handler must determine which buffer is complete and process the data or set a flag that the data must be processed by non-interrupt buffer processing code. Then the next buffer transfer must be set up.

In the interrupt handler:

1. Read the primary channel control word at offset 0x088 and check the `XFERMODE` field. If the field is 0, this means buffer A is complete. If buffer A is complete, then:
 - a. Process the newly received data in buffer A or signal the buffer processing code that buffer A has data available.
 - b. Reprogram the primary channel control word at offset 0x88 according to Table 9-12 on page 707.
2. Read the alternate channel control word at offset 0x288 and check the `XFERMODE` field. If the field is 0, this means buffer B is complete. If buffer B is complete, then:

- a. Process the newly received data in buffer B or signal the buffer processing code that buffer B has data available.
- b. Reprogram the alternate channel control word at offset 0x288 according to Table 9-12 on page 707.

9.3.5 Configuring Channel Assignments

Channel assignments for each μ DMA channel can be changed using the **DMACHMAPn** registers. Each 4-bit field represents a μ DMA channel.

Refer to Table 9-1 on page 688 for channel assignments.

For example, to use UART1 RX on channel 8, configure the **CH8SEL** bit in the **DMACHMAP1** register to be 0x1. If a peripheral is enabled on two different channels, the μ DMA channel that has the highest priority for that peripheral takes precedence. Thus, if UART 1 RX is enabled on both channel 8 and channel 22, the UART1 RX channel 22 priority needs to be lowered before channel 8 UART1 RX can be accessed by the μ DMA.

9.4 Register Map

Table 9-13 on page 709 lists the μ DMA channel control structures and registers. The channel control structure shows the layout of one entry in the channel control table. The channel control table is located in system memory, and the location is determined by the application, thus the base address is n/a (not applicable) and noted as such above the register descriptions. In the table below, the offset for the channel control structures is the offset from the entry in the channel control table. See “Channel Configuration” on page 691 and Table 9-3 on page 692 for a description of how the entries in the channel control table are located in memory. The μ DMA register addresses are given as a hexadecimal increment, relative to the μ DMA base address of 0x400F.F000. Note that the μ DMA module clock must be enabled before the registers can be programmed (see page 392). There must be a delay of 3 system clocks after the μ DMA module clock is enabled before any μ DMA module registers are accessed.

Table 9-13. μ DMA Register Map

Offset	Name	Type	Reset	Description	See page
μDMA Channel Control Structure (Offset from Channel Control Table Base)					
0x000	DMASRCENDP	RW	-	DMA Channel Source Address End Pointer	711
0x004	DMADSTENDP	RW	-	DMA Channel Destination Address End Pointer	712
0x008	DMACHCTL	RW	-	DMA Channel Control Word	713
μDMA Registers (Offset from μDMA Base Address)					
0x000	DMASTAT	RO	0x001F.0000	DMA Status	718
0x004	DMACFG	WO	-	DMA Configuration	720
0x008	DMACTLBASE	RW	0x0000.0000	DMA Channel Control Base Pointer	721
0x00C	DMAALTBASE	RO	0x0000.0200	DMA Alternate Channel Control Base Pointer	722
0x010	DMAWAITSTAT	RO	0x03C3.CF00	DMA Channel Wait-on-Request Status	723
0x014	DMASWREQ	WO	-	DMA Channel Software Request	724

Table 9-13. μ DMA Register Map (continued)

Offset	Name	Type	Reset	Description	See page
0x018	DMAUSEBURSTSET	RW	0x0000.0000	DMA Channel Useburst Set	725
0x01C	DMAUSEBURSTCLR	WO	-	DMA Channel Useburst Clear	726
0x020	DMAREQMASKSET	RW	0x0000.0000	DMA Channel Request Mask Set	727
0x024	DMAREQMASKCLR	WO	-	DMA Channel Request Mask Clear	728
0x028	DMAENASET	RW	0x0000.0000	DMA Channel Enable Set	729
0x02C	DMAENACL	WO	-	DMA Channel Enable Clear	730
0x030	DMAALTSET	RW	0x0000.0000	DMA Channel Primary Alternate Set	731
0x034	DMAALTCLR	WO	-	DMA Channel Primary Alternate Clear	732
0x038	DMAPRIOSET	RW	0x0000.0000	DMA Channel Priority Set	733
0x03C	DMAPRIOCLR	WO	-	DMA Channel Priority Clear	734
0x04C	DMAERRCLR	RW	0x0000.0000	DMA Bus Error Clear	735
0x500	DMACHASGN	RW	0x0000.0000	DMA Channel Assignment	736
0x510	DMACHMAP0	RW	0x0000.0000	DMA Channel Map Select 0	737
0x514	DMACHMAP1	RW	0x0000.0000	DMA Channel Map Select 1	738
0x518	DMACHMAP2	RW	0x0000.0000	DMA Channel Map Select 2	739
0x51C	DMACHMAP3	RW	0x0000.0000	DMA Channel Map Select 3	740
0xFD0	DMAPeriphID4	RO	0x0000.0004	DMA Peripheral Identification 4	745
0xFE0	DMAPeriphID0	RO	0x0000.0030	DMA Peripheral Identification 0	741
0xFE4	DMAPeriphID1	RO	0x0000.00B2	DMA Peripheral Identification 1	742
0xFE8	DMAPeriphID2	RO	0x0000.000B	DMA Peripheral Identification 2	743
0xFEC	DMAPeriphID3	RO	0x0000.0000	DMA Peripheral Identification 3	744
0xFF0	DMAPrimeCellID0	RO	0x0000.000D	DMA PrimeCell Identification 0	746
0xFF4	DMAPrimeCellID1	RO	0x0000.00F0	DMA PrimeCell Identification 1	747
0xFF8	DMAPrimeCellID2	RO	0x0000.0005	DMA PrimeCell Identification 2	748
0xFFC	DMAPrimeCellID3	RO	0x0000.00B1	DMA PrimeCell Identification 3	749

9.5 μ DMA Channel Control Structure

The μ DMA Channel Control Structure holds the transfer settings for a μ DMA channel. Each channel has two control structures, which are located in a table in system memory. Refer to “Channel Configuration” on page 691 for an explanation of the Channel Control Table and the Channel Control Structure.

The channel control structure is one entry in the channel control table. Each channel has a primary and alternate structure. The primary control structures are located at offsets 0x0, 0x10, 0x20 and so on. The alternate control structures are located at offsets 0x200, 0x210, 0x220, and so on.

Register 1: DMA Channel Source Address End Pointer (DMASRCENDP), offset 0x000

DMA Channel Source Address End Pointer (DMASRCENDP) is part of the Channel Control Structure and is used to specify the source address for a μ DMA transfer.

Note: The offset specified is from the base address of the control structure in system memory, not the μ DMA module base address.

DMA Channel Source Address End Pointer (DMASRCENDP)

Base n/a

Offset 0x000

Type RW, reset -

	31	30	29	28	27	26	25	24	23	22	21	20	19	18	17	16
	ADDR															
Type	RW	RW	RW	RW	RW	RW	RW	RW	RW	RW	RW	RW	RW	RW	RW	RW
Reset	-	-	-	-	-	-	-	-	-	-	-	-	-	-	-	-
	15	14	13	12	11	10	9	8	7	6	5	4	3	2	1	0
	ADDR															
Type	RW	RW	RW	RW	RW	RW	RW	RW	RW	RW	RW	RW	RW	RW	RW	RW
Reset	-	-	-	-	-	-	-	-	-	-	-	-	-	-	-	-

Bit/Field	Name	Type	Reset	Description
31:0	ADDR	RW	-	Source Address End Pointer This field points to the last address of the μ DMA transfer source (inclusive). If the source address is not incrementing (the <code>SRCINC</code> field in the <code>DMACHCTL</code> register is 0x3), then this field points at the source location itself (such as a peripheral data register).

Register 2: DMA Channel Destination Address End Pointer (DMADSTENDP), offset 0x004

DMA Channel Destination Address End Pointer (DMADSTENDP) is part of the Channel Control Structure and is used to specify the destination address for a μ DMA transfer.

Note: The offset specified is from the base address of the control structure in system memory, not the μ DMA module base address.

DMA Channel Destination Address End Pointer (DMADSTENDP)

Base n/a

Offset 0x004

Type RW, reset -

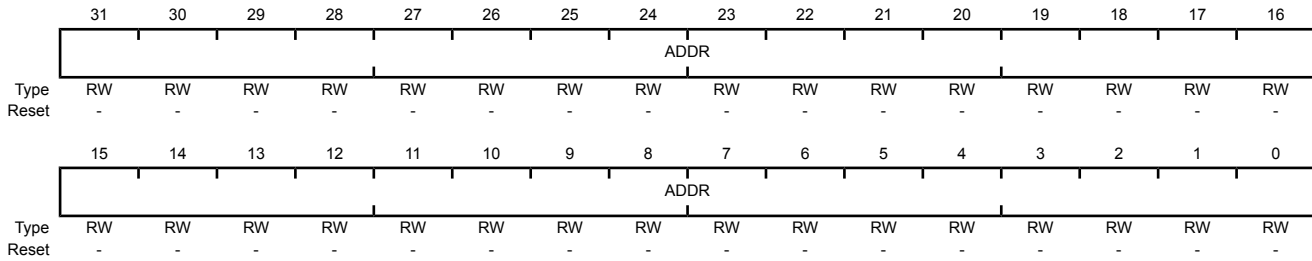

Bit/Field	Name	Type	Reset	Description
31:0	ADDR	RW	-	Destination Address End Pointer This field points to the last address of the μ DMA transfer destination (inclusive). If the destination address is not incrementing (the <i>DSTINC</i> field in the DMACHCTL register is 0x3), then this field points at the destination location itself (such as a peripheral data register).

Register 3: DMA Channel Control Word (DMACHCTL), offset 0x008

DMA Channel Control Word (DMACHCTL) is part of the Channel Control Structure and is used to specify parameters of a μ DMA transfer.

Note: The offset specified is from the base address of the control structure in system memory, not the μ DMA module base address.

DMA Channel Control Word (DMACHCTL)

Base n/a

Offset 0x008

Type RW, reset -

	31	30	29	28	27	26	25	24	23	22	21	20	19	18	17	16
	DSTINC		DSTSIZE		SRCINC		SRCSIZE		reserved		DSTPROTO	reserved		SRCPROTO	ARBSIZE	
Type	RW	RW	RW	RW	RW	RW	RW	RW	RO	RO	RW	RO	RO	RW	RW	RW
Reset	-	-	-	-	-	-	-	-	0	0	0	-	-	0	-	-
	15	14	13	12	11	10	9	8	7	6	5	4	3	2	1	0
	ARBSIZE		XFERSIZE										NXTUSEBURST	XFERMODE		
Type	RW	RW	RW	RW	RW	RW	RW	RW	RW	RW	RW	RW	RW	RW	RW	RW
Reset	-	-	-	-	-	-	-	-	-	-	-	-	-	-	-	-

Bit/Field	Name	Type	Reset	Description										
31:30	DSTINC	RW	-	<p>Destination Address Increment</p> <p>This field configures the destination address increment.</p> <p>The address increment value must be equal or greater than the value of the destination size (DSTSIZE).</p> <table border="1"> <thead> <tr> <th>Value</th> <th>Description</th> </tr> </thead> <tbody> <tr> <td>0x0</td> <td>Byte Increment by 8-bit locations</td> </tr> <tr> <td>0x1</td> <td>Half-word Increment by 16-bit locations</td> </tr> <tr> <td>0x2</td> <td>Word Increment by 32-bit locations</td> </tr> <tr> <td>0x3</td> <td>No increment Address remains set to the value of the Destination Address End Pointer (DMADSTENDP) for the channel</td> </tr> </tbody> </table>	Value	Description	0x0	Byte Increment by 8-bit locations	0x1	Half-word Increment by 16-bit locations	0x2	Word Increment by 32-bit locations	0x3	No increment Address remains set to the value of the Destination Address End Pointer (DMADSTENDP) for the channel
Value	Description													
0x0	Byte Increment by 8-bit locations													
0x1	Half-word Increment by 16-bit locations													
0x2	Word Increment by 32-bit locations													
0x3	No increment Address remains set to the value of the Destination Address End Pointer (DMADSTENDP) for the channel													

Bit/Field	Name	Type	Reset	Description										
29:28	DSTSIZE	RW	-	<p>Destination Data Size This field configures the destination item data size.</p> <p>Note: DSTSIZE must be the same as SRCSIZE.</p> <table border="1"> <thead> <tr> <th>Value</th> <th>Description</th> </tr> </thead> <tbody> <tr> <td>0x0</td> <td>Byte 8-bit data size</td> </tr> <tr> <td>0x1</td> <td>Half-word 16-bit data size</td> </tr> <tr> <td>0x2</td> <td>Word 32-bit data size</td> </tr> <tr> <td>0x3</td> <td>Reserved</td> </tr> </tbody> </table>	Value	Description	0x0	Byte 8-bit data size	0x1	Half-word 16-bit data size	0x2	Word 32-bit data size	0x3	Reserved
Value	Description													
0x0	Byte 8-bit data size													
0x1	Half-word 16-bit data size													
0x2	Word 32-bit data size													
0x3	Reserved													
27:26	SRCINC	RW	-	<p>Source Address Increment This field configures the source address increment. The address increment value must be equal or greater than the value of the source size (SRCSIZE).</p> <table border="1"> <thead> <tr> <th>Value</th> <th>Description</th> </tr> </thead> <tbody> <tr> <td>0x0</td> <td>Byte Increment by 8-bit locations</td> </tr> <tr> <td>0x1</td> <td>Half-word Increment by 16-bit locations</td> </tr> <tr> <td>0x2</td> <td>Word Increment by 32-bit locations</td> </tr> <tr> <td>0x3</td> <td>No increment Address remains set to the value of the Source Address End Pointer (DMASRCENDE) for the channel</td> </tr> </tbody> </table>	Value	Description	0x0	Byte Increment by 8-bit locations	0x1	Half-word Increment by 16-bit locations	0x2	Word Increment by 32-bit locations	0x3	No increment Address remains set to the value of the Source Address End Pointer (DMASRCENDE) for the channel
Value	Description													
0x0	Byte Increment by 8-bit locations													
0x1	Half-word Increment by 16-bit locations													
0x2	Word Increment by 32-bit locations													
0x3	No increment Address remains set to the value of the Source Address End Pointer (DMASRCENDE) for the channel													
25:24	SRCSIZE	RW	-	<p>Source Data Size This field configures the source item data size.</p> <p>Note: DSTSIZE must be the same as SRCSIZE.</p> <table border="1"> <thead> <tr> <th>Value</th> <th>Description</th> </tr> </thead> <tbody> <tr> <td>0x0</td> <td>Byte 8-bit data size.</td> </tr> <tr> <td>0x1</td> <td>Half-word 16-bit data size.</td> </tr> <tr> <td>0x2</td> <td>Word 32-bit data size.</td> </tr> <tr> <td>0x3</td> <td>Reserved</td> </tr> </tbody> </table>	Value	Description	0x0	Byte 8-bit data size.	0x1	Half-word 16-bit data size.	0x2	Word 32-bit data size.	0x3	Reserved
Value	Description													
0x0	Byte 8-bit data size.													
0x1	Half-word 16-bit data size.													
0x2	Word 32-bit data size.													
0x3	Reserved													
23:22	reserved	RO	0	Software should not rely on the value of a reserved bit. To provide compatibility with future products, the value of a reserved bit should be preserved across a read-modify-write operation.										

Bit/Field	Name	Type	Reset	Description																								
21	DSTPROTO	RW	0	<p>Destination Privilege Access</p> <p>This bit controls the privilege access protection for destination data writes.</p> <p>Note: For AES,DES, or SHA accesses, this bit must be set to 1.</p> <table border="1"> <thead> <tr> <th>Value</th> <th>Description</th> </tr> </thead> <tbody> <tr> <td>0</td> <td>The access is non-privileged.</td> </tr> <tr> <td>1</td> <td>The access is privileged.</td> </tr> </tbody> </table>	Value	Description	0	The access is non-privileged.	1	The access is privileged.																		
Value	Description																											
0	The access is non-privileged.																											
1	The access is privileged.																											
20:19	reserved	RO	-	Software should not rely on the value of a reserved bit. To provide compatibility with future products, the value of a reserved bit should be preserved across a read-modify-write operation.																								
18	SRCPROTO	RW	0	<p>Source Privilege Access</p> <p>This bit controls the privilege access protection for source data reads.</p> <p>Note: For AES,DES, or SHA accesses, this bit must be set to 1.</p> <table border="1"> <thead> <tr> <th>Value</th> <th>Description</th> </tr> </thead> <tbody> <tr> <td>0</td> <td>The access is non-privileged.</td> </tr> <tr> <td>1</td> <td>The access is privileged.</td> </tr> </tbody> </table>	Value	Description	0	The access is non-privileged.	1	The access is privileged.																		
Value	Description																											
0	The access is non-privileged.																											
1	The access is privileged.																											
17:14	ARBSIZE	RW	-	<p>Arbitration Size</p> <p>This field configures the number of transfers that can occur before the μDMA controller re-arbitrates. The possible arbitration rate configurations represent powers of 2 and are shown below.</p> <table border="1"> <thead> <tr> <th>Value</th> <th>Description</th> </tr> </thead> <tbody> <tr> <td>0x0</td> <td>1 Transfer Arbitrates after each μDMA transfer</td> </tr> <tr> <td>0x1</td> <td>2 Transfers</td> </tr> <tr> <td>0x2</td> <td>4 Transfers</td> </tr> <tr> <td>0x3</td> <td>8 Transfers</td> </tr> <tr> <td>0x4</td> <td>16 Transfers</td> </tr> <tr> <td>0x5</td> <td>32 Transfers</td> </tr> <tr> <td>0x6</td> <td>64 Transfers</td> </tr> <tr> <td>0x7</td> <td>128 Transfers</td> </tr> <tr> <td>0x8</td> <td>256 Transfers</td> </tr> <tr> <td>0x9</td> <td>512 Transfers</td> </tr> <tr> <td>0xA-0xF</td> <td>1024 Transfers</td> </tr> </tbody> </table> <p>In this configuration, no arbitration occurs during the μDMA transfer because the maximum transfer size is 1024.</p>	Value	Description	0x0	1 Transfer Arbitrates after each μ DMA transfer	0x1	2 Transfers	0x2	4 Transfers	0x3	8 Transfers	0x4	16 Transfers	0x5	32 Transfers	0x6	64 Transfers	0x7	128 Transfers	0x8	256 Transfers	0x9	512 Transfers	0xA-0xF	1024 Transfers
Value	Description																											
0x0	1 Transfer Arbitrates after each μ DMA transfer																											
0x1	2 Transfers																											
0x2	4 Transfers																											
0x3	8 Transfers																											
0x4	16 Transfers																											
0x5	32 Transfers																											
0x6	64 Transfers																											
0x7	128 Transfers																											
0x8	256 Transfers																											
0x9	512 Transfers																											
0xA-0xF	1024 Transfers																											

Bit/Field	Name	Type	Reset	Description																		
13:4	XFERSIZE	RW	-	<p>Transfer Size (minus 1)</p> <p>This field configures the total number of items to transfer. The value of this field is 1 less than the number to transfer (value 0 means transfer 1 item). The maximum value for this 10-bit field is 1023 which represents a transfer size of 1024 items.</p> <p>The transfer size is the number of items, not the number of bytes. If the data size is 32 bits, then this value is the number of 32-bit words to transfer.</p> <p>The μDMA controller updates this field immediately prior to entering the arbitration process, so it contains the number of outstanding items that is necessary to complete the μDMA cycle.</p>																		
3	NXTUSEBURST	RW	-	<p>Next Useburst</p> <p>This field controls whether the Useburst <code>SET[n]</code> bit is automatically set for the last transfer of a peripheral scatter-gather operation. Normally, for the last transfer, if the number of remaining items to transfer is less than the arbitration size, the μDMA controller uses single transfers to complete the transaction. If this bit is set, then the controller uses a burst transfer to complete the last transfer.</p>																		
2:0	XFERMODE	RW	-	<p>μDMA Transfer Mode</p> <p>This field configures the operating mode of the μDMA cycle. Refer to "Transfer Modes" on page 693 for a detailed explanation of transfer modes.</p> <p>Because this register is in system RAM, it has no reset value. Therefore, this field should be initialized to 0 before the channel is enabled.</p> <table border="1"> <thead> <tr> <th>Value</th> <th>Description</th> </tr> </thead> <tbody> <tr> <td>0x0</td> <td>Stop</td> </tr> <tr> <td>0x1</td> <td>Basic</td> </tr> <tr> <td>0x2</td> <td>Auto-Request</td> </tr> <tr> <td>0x3</td> <td>Ping-Pong</td> </tr> <tr> <td>0x4</td> <td>Memory Scatter-Gather</td> </tr> <tr> <td>0x5</td> <td>Alternate Memory Scatter-Gather</td> </tr> <tr> <td>0x6</td> <td>Peripheral Scatter-Gather</td> </tr> <tr> <td>0x7</td> <td>Alternate Peripheral Scatter-Gather</td> </tr> </tbody> </table>	Value	Description	0x0	Stop	0x1	Basic	0x2	Auto-Request	0x3	Ping-Pong	0x4	Memory Scatter-Gather	0x5	Alternate Memory Scatter-Gather	0x6	Peripheral Scatter-Gather	0x7	Alternate Peripheral Scatter-Gather
Value	Description																					
0x0	Stop																					
0x1	Basic																					
0x2	Auto-Request																					
0x3	Ping-Pong																					
0x4	Memory Scatter-Gather																					
0x5	Alternate Memory Scatter-Gather																					
0x6	Peripheral Scatter-Gather																					
0x7	Alternate Peripheral Scatter-Gather																					

XFERMODE Bit Field Values.

Stop

Channel is stopped or configuration data is invalid. No more transfers can occur.

Basic

For each trigger (whether from a peripheral or a software request), the μ DMA controller performs the number of transfers specified by the `ARBSIZE` field.

Auto-Request

The initial request (software- or peripheral-initiated) is sufficient to complete the entire transfer of `XFERSIZE` items without any further requests.

Ping-Pong

This mode uses both the primary and alternate control structures for this channel. When the number of transfers specified by the `XFERSIZE` field have completed for the current control structure (primary or alternate), the μ DMA controller switches to the other one. These switches continue until one of the control structures is not set to ping-pong mode. At that point, the μ DMA controller stops. An interrupt is generated on completion of the transfers configured by each control structure. See “Ping-Pong” on page 693.

Memory Scatter-Gather

When using this mode, the primary control structure for the channel is configured to allow a list of operations (tasks) to be performed. The source address pointer specifies the start of a table of tasks to be copied to the alternate control structure for this channel. The `XFERMODE` field for the alternate control structure should be configured to 0x5 (Alternate memory scatter-gather) to perform the task. When the task completes, the μ DMA switches back to the primary channel control structure, which then copies the next task to the alternate control structure. This process continues until the table of tasks is empty. The last task must have an `XFERMODE` value other than 0x5. Note that for continuous operation, the last task can update the primary channel control structure back to the start of the list or to another list. See “Memory Scatter-Gather” on page 695.

Alternate Memory Scatter-Gather

This value must be used in the alternate channel control data structure when the μ DMA controller operates in Memory Scatter-Gather mode.

Peripheral Scatter-Gather

This value must be used in the primary channel control data structure when the μ DMA controller operates in Peripheral Scatter-Gather mode. In this mode, the μ DMA controller operates exactly the same as in Memory Scatter-Gather mode, except that instead of performing the number of transfers specified by the `XFERSIZE` field in the alternate control structure at one time, the μ DMA controller only performs the number of transfers specified by the `ARBSIZE` field per trigger; see Basic mode for details. See “Peripheral Scatter-Gather” on page 698.

Alternate Peripheral Scatter-Gather

This value must be used in the alternate channel control data structure when the μ DMA controller operates in Peripheral Scatter-Gather mode.

9.6 μ DMA Register Descriptions

The register addresses given are relative to the μ DMA base address of 0x400F.F000.

Register 4: DMA Status (DMASTAT), offset 0x000

The **DMA Status (DMASTAT)** register returns the status of the μ DMA controller. You cannot read this register when the μ DMA controller is in the reset state.

DMA Status (DMASTAT)

Base 0x400F.F000

Offset 0x000

Type RO, reset 0x001F.0000

	31	30	29	28	27	26	25	24	23	22	21	20	19	18	17	16
	reserved											DMACHANS				
Type	RO	RO	RO	RO	RO	RO	RO	RO	RO	RO	RO	RO	RO	RO	RO	RO
Reset	0	0	0	0	0	0	0	0	0	0	0	1	1	1	1	1
	15	14	13	12	11	10	9	8	7	6	5	4	3	2	1	0
	reserved								STATE				reserved			MASTEN
Type	RO	RO	RO	RO	RO	RO	RO	RO	RO	RO	RO	RO	RO	RO	RO	RO
Reset	0	0	0	0	0	0	0	0	0	0	0	0	0	0	0	0

Bit/Field	Name	Type	Reset	Description																								
31:21	reserved	RO	0x000	Software should not rely on the value of a reserved bit. To provide compatibility with future products, the value of a reserved bit should be preserved across a read-modify-write operation.																								
20:16	DMACHANS	RO	0x1F	Available μ DMA Channels Minus 1 This field contains a value equal to the number of μ DMA channels the μ DMA controller is configured to use, minus one. The value of 0x1F corresponds to 32 μ DMA channels.																								
15:8	reserved	RO	0x00	Software should not rely on the value of a reserved bit. To provide compatibility with future products, the value of a reserved bit should be preserved across a read-modify-write operation.																								
7:4	STATE	RO	0x0	Control State Machine Status This field shows the current status of the control state machine. Status can be one of the following. <table border="1"> <thead> <tr> <th>Value</th> <th>Description</th> </tr> </thead> <tbody> <tr><td>0x0</td><td>Idle</td></tr> <tr><td>0x1</td><td>Reading channel controller data.</td></tr> <tr><td>0x2</td><td>Reading source end pointer.</td></tr> <tr><td>0x3</td><td>Reading destination end pointer.</td></tr> <tr><td>0x4</td><td>Reading source data.</td></tr> <tr><td>0x5</td><td>Writing destination data.</td></tr> <tr><td>0x6</td><td>Waiting for μDMA request to clear.</td></tr> <tr><td>0x7</td><td>Writing channel controller data.</td></tr> <tr><td>0x8</td><td>Stalled</td></tr> <tr><td>0x9</td><td>Done</td></tr> <tr><td>0xA-0xF</td><td>Undefined</td></tr> </tbody> </table>	Value	Description	0x0	Idle	0x1	Reading channel controller data.	0x2	Reading source end pointer.	0x3	Reading destination end pointer.	0x4	Reading source data.	0x5	Writing destination data.	0x6	Waiting for μ DMA request to clear.	0x7	Writing channel controller data.	0x8	Stalled	0x9	Done	0xA-0xF	Undefined
Value	Description																											
0x0	Idle																											
0x1	Reading channel controller data.																											
0x2	Reading source end pointer.																											
0x3	Reading destination end pointer.																											
0x4	Reading source data.																											
0x5	Writing destination data.																											
0x6	Waiting for μ DMA request to clear.																											
0x7	Writing channel controller data.																											
0x8	Stalled																											
0x9	Done																											
0xA-0xF	Undefined																											
3:1	reserved	RO	0x0	Software should not rely on the value of a reserved bit. To provide compatibility with future products, the value of a reserved bit should be preserved across a read-modify-write operation.																								

Bit/Field	Name	Type	Reset	Description
0	MASTEN	RO	0	Master Enable Status
				Value Description
			0	The μ DMA controller is disabled.
			1	The μ DMA controller is enabled.

Register 5: DMA Configuration (DMACFG), offset 0x004

The **DMACFG** register controls the configuration of the μ DMA controller.

DMA Configuration (DMACFG)

Base 0x400F.F000

Offset 0x004

Type WO, reset -

	31	30	29	28	27	26	25	24	23	22	21	20	19	18	17	16
	reserved															
Type	WO	WO	WO	WO	WO	WO	WO	WO	WO	WO	WO	WO	WO	WO	WO	WO
Reset	-	-	-	-	-	-	-	-	-	-	-	-	-	-	-	-
	15	14	13	12	11	10	9	8	7	6	5	4	3	2	1	0
	reserved															MASTEN
Type	WO	WO	WO	WO	WO	WO	WO	WO	WO	WO	WO	WO	WO	WO	WO	WO
Reset	-	-	-	-	-	-	-	-	-	-	-	-	-	-	-	-

Bit/Field	Name	Type	Reset	Description
31:1	reserved	WO	-	Software should not rely on the value of a reserved bit. To provide compatibility with future products, the value of a reserved bit should be preserved across a read-modify-write operation.
0	MASTEN	WO	-	Controller Master Enable
				Value Description
				0 Disables the μ DMA controller.
				1 Enables μ DMA controller.

Register 6: DMA Channel Control Base Pointer (DMACTLBASE), offset 0x008

The **DMACTLBASE** register must be configured so that the base pointer points to a location in system memory.

The amount of system memory that must be assigned to the μ DMA controller depends on the number of μ DMA channels used and whether the alternate channel control data structure is used. See “Channel Configuration” on page 691 for details about the Channel Control Table. The base address must be aligned on a 1024-byte boundary. This register cannot be read when the μ DMA controller is in the reset state.

DMA Channel Control Base Pointer (DMACTLBASE)

Base 0x400F.F000

Offset 0x008

Type RW, reset 0x0000.0000

	31	30	29	28	27	26	25	24	23	22	21	20	19	18	17	16
	ADDR															
Type	RW	RW	RW	RW	RW	RW	RW	RW	RW	RW	RW	RW	RW	RW	RW	RW
Reset	0	0	0	0	0	0	0	0	0	0	0	0	0	0	0	0
	15	14	13	12	11	10	9	8	7	6	5	4	3	2	1	0
	ADDR						reserved									
Type	RW	RW	RW	RW	RW	RW	RO	RO	RO	RO	RO	RO	RO	RO	RO	RO
Reset	0	0	0	0	0	0	0	0	0	0	0	0	0	0	0	0

Bit/Field	Name	Type	Reset	Description
31:10	ADDR	RW	0x0000.00	Channel Control Base Address This field contains the pointer to the base address of the channel control table. The base address must be 1024-byte aligned.
9:0	reserved	RO	0x00	Software should not rely on the value of a reserved bit. To provide compatibility with future products, the value of a reserved bit should be preserved across a read-modify-write operation.

Register 7: DMA Alternate Channel Control Base Pointer (DMAALTBASE), offset 0x00C

The **DMAALTBASE** register returns the base address of the alternate channel control data. This register removes the necessity for application software to calculate the base address of the alternate channel control structures. This register cannot be read when the μ DMA controller is in the reset state.

DMA Alternate Channel Control Base Pointer (DMAALTBASE)

Base 0x400F.F000
 Offset 0x00C
 Type RO, reset 0x0000.0200

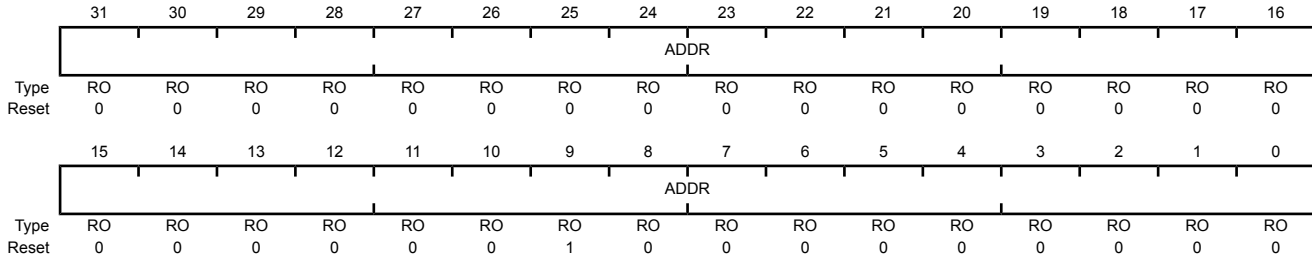

Bit/Field	Name	Type	Reset	Description
31:0	ADDR	RO	0x0000.0200	Alternate Channel Address Pointer This field provides the base address of the alternate channel control structures.

Register 8: DMA Channel Wait-on-Request Status (DMAWAITSTAT), offset 0x010

This read-only register indicates that the μ DMA channel is waiting on a request. A peripheral can hold off the μ DMA from performing a single request until the peripheral is ready for a burst request to enhance the μ DMA performance. The use of this feature is dependent on the design of the peripheral and is not controllable by software in any way. This register cannot be read when the μ DMA controller is in the reset state.

DMA Channel Wait-on-Request Status (DMAWAITSTAT)

Base 0x400F.F000
Offset 0x010
Type RO, reset 0x03C3.CF00

	31	30	29	28	27	26	25	24	23	22	21	20	19	18	17	16
	WAITREQ[n]															
Type	RO	RO	RO	RO	RO	RO	RO	RO	RO	RO	RO	RO	RO	RO	RO	RO
Reset	0	0	0	0	0	0	1	1	1	1	0	0	0	0	1	1
	15	14	13	12	11	10	9	8	7	6	5	4	3	2	1	0
	WAITREQ[n]															
Type	RO	RO	RO	RO	RO	RO	RO	RO	RO	RO	RO	RO	RO	RO	RO	RO
Reset	1	1	0	0	1	1	1	1	0	0	0	0	0	0	0	0

Bit/Field	Name	Type	Reset	Description
31:0	WAITREQ[n]	RO	0x03C3.CF00	Channel [n] Wait Status These bits provide the channel wait-on-request status. Bit 0 corresponds to channel 0.

Value Description

0	The corresponding channel is not waiting on a request.
1	The corresponding channel is waiting on a request.

Register 9: DMA Channel Software Request (DMASWREQ), offset 0x014

Each bit of the **DMASWREQ** register represents the corresponding μ DMA channel. Setting a bit generates a request for the specified μ DMA channel.

DMA Channel Software Request (DMASWREQ)

Base 0x400F.F000

Offset 0x014

Type WO, reset -



Bit/Field	Name	Type	Reset	Description
31:0	SWREQ[n]	WO	-	Channel [n] Software Request These bits generate software requests. Bit 0 corresponds to channel 0.
				Value Description
				0 No request generated.
				1 Generate a software request for the corresponding channel.
				These bits are automatically cleared when the software request has been completed.

Register 10: DMA Channel Useburst Set (DMAUSEBURSTSET), offset 0x018

Each bit of the **DMAUSEBURSTSET** register represents the corresponding μ DMA channel. Setting a bit disables the channel's single request input from generating requests, configuring the channel to only accept burst requests. Reading the register returns the status of USEBURST.

If the amount of data to transfer is a multiple of the arbitration (burst) size, the corresponding $SET[n]$ bit is cleared after completing the final transfer. If there are fewer items remaining to transfer than the arbitration (burst) size, the μ DMA controller automatically clears the corresponding $SET[n]$ bit, allowing the remaining items to transfer using single requests. In order to resume transfers using burst requests, the corresponding bit must be set again. A bit should not be set if the corresponding peripheral does not support the burst request model.

Refer to “Request Types” on page 690 for more details about request types.

DMA Channel Useburst Set (DMAUSEBURSTSET)

Base 0x400F.F000
Offset 0x018
Type RW, reset 0x0000.0000

	31	30	29	28	27	26	25	24	23	22	21	20	19	18	17	16
	SET[n]															
Type	RW	RW	RW	RW	RW	RW	RW	RW	RW	RW	RW	RW	RW	RW	RW	RW
Reset	0	0	0	0	0	0	0	0	0	0	0	0	0	0	0	0
	15	14	13	12	11	10	9	8	7	6	5	4	3	2	1	0
	SET[n]															
Type	RW	RW	RW	RW	RW	RW	RW	RW	RW	RW	RW	RW	RW	RW	RW	RW
Reset	0	0	0	0	0	0	0	0	0	0	0	0	0	0	0	0

Bit/Field	Name	Type	Reset	Description
31:0	SET[n]	RW	0x0000.0000	Channel [n] Useburst Set

Value	Description
0	μ DMA channel [n] responds to single or burst requests.
1	μ DMA channel [n] responds only to burst requests.

Bit 0 corresponds to channel 0. This bit is automatically cleared as described above. A bit can also be manually cleared by setting the corresponding $CLR[n]$ bit in the **DMAUSEBURSTCLR** register.

Register 11: DMA Channel Useburst Clear (DMAUSEBURSTCLR), offset 0x01C

Each bit of the **DMAUSEBURSTCLR** register represents the corresponding μ DMA channel. Setting a bit clears the corresponding **SET[n]** bit in the **DMAUSEBURSTSET** register.

DMA Channel Useburst Clear (DMAUSEBURSTCLR)

Base 0x400F.F000

Offset 0x01C

Type WO, reset -



Bit/Field	Name	Type	Reset	Description
31:0	CLR[n]	WO	-	Channel [n] Useburst Clear

Value Description

0 No effect.

1 Setting a bit clears the corresponding **SET[n]** bit in the **DMAUSEBURSTSET** register meaning that μ DMA channel [n] responds to single and burst requests.

Register 12: DMA Channel Request Mask Set (DMAREQMASKSET), offset 0x020

Each bit of the **DMAREQMASKSET** register represents the corresponding μ DMA channel. Setting a bit disables μ DMA requests for the channel. Reading the register returns the request mask status. When a μ DMA channel's request is masked, that means the peripheral can no longer request μ DMA transfers. The channel can then be used for software-initiated transfers.

DMA Channel Request Mask Set (DMAREQMASKSET)

Base 0x400F.F000
Offset 0x020
Type RW, reset 0x0000.0000

	31	30	29	28	27	26	25	24	23	22	21	20	19	18	17	16
	SET[n]															
Type	RW	RW	RW	RW	RW	RW	RW	RW	RW	RW	RW	RW	RW	RW	RW	RW
Reset	0	0	0	0	0	0	0	0	0	0	0	0	0	0	0	0
	15	14	13	12	11	10	9	8	7	6	5	4	3	2	1	0
	SET[n]															
Type	RW	RW	RW	RW	RW	RW	RW	RW	RW	RW	RW	RW	RW	RW	RW	RW
Reset	0	0	0	0	0	0	0	0	0	0	0	0	0	0	0	0

Bit/Field	Name	Type	Reset	Description
31:0	SET[n]	RW	0x0000.0000	Channel [n] Request Mask Set

Value Description

Value	Description
0	The peripheral associated with channel [n] is enabled to request μ DMA transfers.
1	The peripheral associated with channel [n] is not able to request μ DMA transfers. Channel [n] may be used for software-initiated transfers.

Bit 0 corresponds to channel 0. A bit can only be cleared by setting the corresponding CLR[n] bit in the **DMAREQMASKCLR** register.

Register 13: DMA Channel Request Mask Clear (DMAREQMASKCLR), offset 0x024

Each bit of the **DMAREQMASKCLR** register represents the corresponding μ DMA channel. Setting a bit clears the corresponding **SET[n]** bit in the **DMAREQMASKSET** register.

DMA Channel Request Mask Clear (DMAREQMASKCLR)

Base 0x400F.F000

Offset 0x024

Type WO, reset -



Bit/Field	Name	Type	Reset	Description
31:0	CLR[n]	WO	-	Channel [n] Request Mask Clear

Value Description

0 No effect.

1 Setting a bit clears the corresponding **SET[n]** bit in the **DMAREQMASKSET** register meaning that the peripheral associated with channel [n] is enabled to request μ DMA transfers.

Register 14: DMA Channel Enable Set (DMAENASET), offset 0x028

Each bit of the **DMAENASET** register represents the corresponding μ DMA channel. Setting a bit enables the corresponding μ DMA channel. Reading the register returns the enable status of the channels. If a channel is enabled but the request mask is set (**DMAREQMASKSET**), then the channel can be used for software-initiated transfers.

DMA Channel Enable Set (DMAENASET)

Base 0x400F.F000
Offset 0x028
Type RW, reset 0x0000.0000

	31	30	29	28	27	26	25	24	23	22	21	20	19	18	17	16
	SET[n]															
Type	RW	RW	RW	RW	RW	RW	RW	RW	RW	RW	RW	RW	RW	RW	RW	RW
Reset	0	0	0	0	0	0	0	0	0	0	0	0	0	0	0	0
	15	14	13	12	11	10	9	8	7	6	5	4	3	2	1	0
	SET[n]															
Type	RW	RW	RW	RW	RW	RW	RW	RW	RW	RW	RW	RW	RW	RW	RW	RW
Reset	0	0	0	0	0	0	0	0	0	0	0	0	0	0	0	0

Bit/Field	Name	Type	Reset	Description
31:0	SET[n]	RW	0x0000.0000	Channel [n] Enable Set

Value	Description
0	μ DMA Channel [n] is disabled.
1	μ DMA Channel [n] is enabled.

Bit 0 corresponds to channel 0. A bit can only be cleared by setting the corresponding **CLR[n]** bit in the **DMAENACL** register or when the end of a μ DMA transfer occurs.

Register 15: DMA Channel Enable Clear (DMAENACLRL), offset 0x02C

Each bit of the **DMAENACLRL** register represents the corresponding μ DMA channel. Setting a bit clears the corresponding **SET[n]** bit in the **DMAENASET** register.

DMA Channel Enable Clear (DMAENACLRL)

Base 0x400F.F000

Offset 0x02C

Type WO, reset -



Bit/Field	Name	Type	Reset	Description
31:0	CLR[n]	WO	-	Clear Channel [n] Enable Clear

Value	Description
0	No effect.
1	Setting a bit clears the corresponding SET[n] bit in the DMAENASET register meaning that channel [n] is disabled for μ DMA transfers.

Note: The controller disables a channel when it completes the μ DMA cycle.

Register 16: DMA Channel Primary Alternate Set (DMAALTSET), offset 0x030

Each bit of the **DMAALTSET** register represents the corresponding μ DMA channel. Setting a bit configures the μ DMA channel to use the alternate control data structure. Reading the register returns the status of which control data structure is in use for the corresponding μ DMA channel.

DMA Channel Primary Alternate Set (DMAALTSET)

Base 0x400F.F000
Offset 0x030
Type RW, reset 0x0000.0000

	31	30	29	28	27	26	25	24	23	22	21	20	19	18	17	16
	SET[n]															
Type	RW	RW	RW	RW	RW	RW	RW	RW	RW	RW	RW	RW	RW	RW	RW	RW
Reset	0	0	0	0	0	0	0	0	0	0	0	0	0	0	0	0
	15	14	13	12	11	10	9	8	7	6	5	4	3	2	1	0
	SET[n]															
Type	RW	RW	RW	RW	RW	RW	RW	RW	RW	RW	RW	RW	RW	RW	RW	RW
Reset	0	0	0	0	0	0	0	0	0	0	0	0	0	0	0	0

Bit/Field	Name	Type	Reset	Description
31:0	SET[n]	RW	0x0000.0000	Channel [n] Alternate Set

Value Description

Value	Description
0	μ DMA channel [n] is using the primary control structure.
1	μ DMA channel [n] is using the alternate control structure.

Bit 0 corresponds to channel 0. A bit can only be cleared by setting the corresponding CLR[n] bit in the **DMAALTCLR** register.

Note: For Ping-Pong and Scatter-Gather cycle types, the μ DMA controller automatically sets these bits to select the alternate channel control data structure.

Register 17: DMA Channel Primary Alternate Clear (DMAALTCLR), offset 0x034

Each bit of the **DMAALTCLR** register represents the corresponding μ DMA channel. Setting a bit clears the corresponding **SET[n]** bit in the **DMAALTSET** register.

DMA Channel Primary Alternate Clear (DMAALTCLR)

Base 0x400F.F000

Offset 0x034

Type WO, reset -

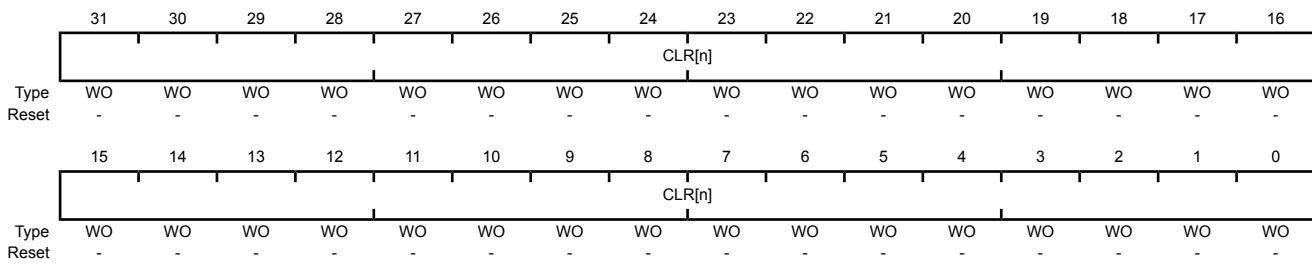

Bit/Field	Name	Type	Reset	Description
31:0	CLR[n]	WO	-	Channel [n] Alternate Clear

Value	Description
0	No effect.
1	Setting a bit clears the corresponding SET[n] bit in the DMAALTSET register meaning that channel [n] is using the primary control structure.

Note: For Ping-Pong and Scatter-Gather cycle types, the μ DMA controller automatically sets these bits to select the alternate channel control data structure.

Register 18: DMA Channel Priority Set (DMAPRIOSET), offset 0x038

Each bit of the **DMAPRIOSET** register represents the corresponding μ DMA channel. Setting a bit configures the μ DMA channel to have a high priority level. Reading the register returns the status of the channel priority mask.

DMA Channel Priority Set (DMAPRIOSET)

Base 0x400F.F000

Offset 0x038

Type RW, reset 0x0000.0000

	31	30	29	28	27	26	25	24	23	22	21	20	19	18	17	16
	SET[n]															
Type	RW	RW	RW	RW	RW	RW	RW	RW	RW	RW	RW	RW	RW	RW	RW	RW
Reset	0	0	0	0	0	0	0	0	0	0	0	0	0	0	0	0
	15	14	13	12	11	10	9	8	7	6	5	4	3	2	1	0
	SET[n]															
Type	RW	RW	RW	RW	RW	RW	RW	RW	RW	RW	RW	RW	RW	RW	RW	RW
Reset	0	0	0	0	0	0	0	0	0	0	0	0	0	0	0	0

Bit/Field	Name	Type	Reset	Description
31:0	SET[n]	RW	0x0000.0000	Channel [n] Priority Set

Value Description

0 μ DMA channel [n] is using the default priority level.1 μ DMA channel [n] is using a high priority level.

Bit 0 corresponds to channel 0. A bit can only be cleared by setting the corresponding CLR[n] bit in the **DMAPRIOCLR** register.

Register 19: DMA Channel Priority Clear (DMAPRIOCLR), offset 0x03C

Each bit of the **DMAPRIOCLR** register represents the corresponding μ DMA channel. Setting a bit clears the corresponding **SET[n]** bit in the **DMAPRIOSET** register.

DMA Channel Priority Clear (DMAPRIOCLR)

Base 0x400F.F000

Offset 0x03C

Type WO, reset -



Bit/Field	Name	Type	Reset	Description
31:0	CLR[n]	WO	-	Channel [n] Priority Clear
				Value Description
				0 No effect.
				1 Setting a bit clears the corresponding SET[n] bit in the DMAPRIOSET register meaning that channel [n] is using the default priority level.

Register 20: DMA Bus Error Clear (DMAERRCLR), offset 0x04C

The **DMAERRCLR** register is used to read and clear the μ DMA bus error status. The error status is set if the μ DMA controller encountered a bus error while performing a transfer. If a bus error occurs on a channel, that channel is automatically disabled by the μ DMA controller. The other channels are unaffected.

DMA Bus Error Clear (DMAERRCLR)

Base 0x400F.F000
Offset 0x04C
Type RW, reset 0x0000.0000

	31	30	29	28	27	26	25	24	23	22	21	20	19	18	17	16	
	reserved																
Type	RO	RO	RO	RO	RO	RO	RO	RO	RO	RO	RO	RO	RO	RO	RO	RO	
Reset	0	0	0	0	0	0	0	0	0	0	0	0	0	0	0	0	
	15	14	13	12	11	10	9	8	7	6	5	4	3	2	1	0	
	reserved															ERRCLR	
Type	RO	RO	RO	RO	RO	RO	RO	RO	RO	RO	RO	RO	RO	RO	RO	RO	RW1C
Reset	0	0	0	0	0	0	0	0	0	0	0	0	0	0	0	0	0

Bit/Field	Name	Type	Reset	Description
31:1	reserved	RO	0x0000.000	Software should not rely on the value of a reserved bit. To provide compatibility with future products, the value of a reserved bit should be preserved across a read-modify-write operation.

0	ERRCLR	RW1C	0	μ DMA Bus Error Status
---	--------	------	---	----------------------------

Value Description

0	No bus error is pending.
1	A bus error is pending.

This bit is cleared by writing a 1 to it.

Register 21: DMA Channel Assignment (DMACHASGN), offset 0x500

Each bit of the **DMACHASGN** register represents the corresponding μ DMA channel. Setting a bit selects the secondary channel assignment as specified in Table 9-1 on page 688.

Note: This register is provided to support legacy software. New software should use the **DMACHMAPn** registers. If a bit is clear in this register, the corresponding field in the **DMACHMAPn** registers is configured to 0x0. If a bit is set in this register, the corresponding field is configured to 0x1. If this register is read, a bit reads as 0 if the corresponding **DMACHMAPn** register field value is equal to 0, otherwise it reads as 1 if the corresponding **DMACHMAPn** register field value is not equal to 0.

DMA Channel Assignment (DMACHASGN)

Base 0x400F.F000
 Offset 0x500
 Type RW, reset 0x0000.0000



Bit/Field	Name	Type	Reset	Description
31:0	CHASGN[n]	RW	-	Channel [n] Assignment Select
				Value Description
				0 Use the primary channel assignment.
				1 Use the secondary channel assignment.

Register 22: DMA Channel Map Select 0 (DMACHMAP0), offset 0x510

Each 4-bit field of the **DMACHMAP0** register configures the μ DMA channel assignment as specified in Table 9-1 on page 688.

Note: To support legacy software which uses the **DMA Channel Assignment (DMACHASGN)** register, a value of 0x0 is equivalent to a **DMACHASGN** bit being clear, and a value of 0x1 is equivalent to a **DMACHASGN** bit being set.

DMA Channel Map Select 0 (DMACHMAP0)

Base 0x400F.F000
Offset 0x510
Type RW, reset 0x0000.0000

	31	30	29	28	27	26	25	24	23	22	21	20	19	18	17	16
	CH7SEL				CH6SEL				CH5SEL				CH4SEL			
Type	RW	RW	RW	RW	RW	RW	RW	RW	RW	RW	RW	RW	RW	RW	RW	RW
Reset	0	0	0	0	0	0	0	0	0	0	0	0	0	0	0	0
	15	14	13	12	11	10	9	8	7	6	5	4	3	2	1	0
	CH3SEL				CH2SEL				CH1SEL				CH0SEL			
Type	RW	RW	RW	RW	RW	RW	RW	RW	RW	RW	RW	RW	RW	RW	RW	RW
Reset	0	0	0	0	0	0	0	0	0	0	0	0	0	0	0	0

Bit/Field	Name	Type	Reset	Description
31:28	CH7SEL	RW	0x00	μ DMA Channel 7 Source Select See Table 9-1 on page 688 for channel assignments.
27:24	CH6SEL	RW	0x00	μ DMA Channel 6 Source Select See Table 9-1 on page 688 for channel assignments.
23:20	CH5SEL	RW	0x00	μ DMA Channel 5 Source Select See Table 9-1 on page 688 for channel assignments.
19:16	CH4SEL	RW	0x00	μ DMA Channel 4 Source Select See Table 9-1 on page 688 for channel assignments.
15:12	CH3SEL	RW	0x00	μ DMA Channel 3 Source Select See Table 9-1 on page 688 for channel assignments.
11:8	CH2SEL	RW	0x00	μ DMA Channel 2 Source Select See Table 9-1 on page 688 for channel assignments.
7:4	CH1SEL	RW	0x00	μ DMA Channel 1 Source Select See Table 9-1 on page 688 for channel assignments.
3:0	CH0SEL	RW	0x00	μ DMA Channel 0 Source Select See Table 9-1 on page 688 for channel assignments.

Register 23: DMA Channel Map Select 1 (DMACHMAP1), offset 0x514

Each 4-bit field of the **DMACHMAP1** register configures the μDMA channel assignment as specified in Table 9-1 on page 688.

Note: To support legacy software which uses the **DMA Channel Assignment (DMACHASGN)** register, a value of 0x0 is equivalent to a **DMACHASGN** bit being clear, and a value of 0x1 is equivalent to a **DMACHASGN** bit being set.

DMA Channel Map Select 1 (DMACHMAP1)

Base 0x400F.F000
 Offset 0x514
 Type RW, reset 0x0000.0000

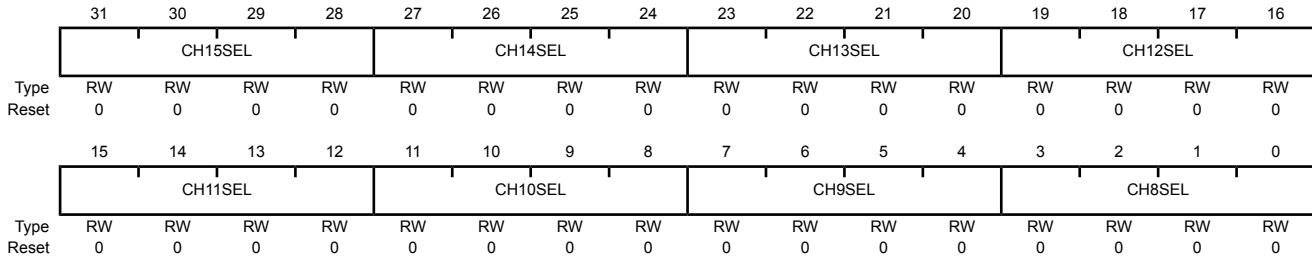

Bit/Field	Name	Type	Reset	Description
31:28	CH15SEL	RW	0x00	μDMA Channel 15 Source Select See Table 9-1 on page 688 for channel assignments.
27:24	CH14SEL	RW	0x00	μDMA Channel 14 Source Select See Table 9-1 on page 688 for channel assignments.
23:20	CH13SEL	RW	0x00	μDMA Channel 13 Source Select See Table 9-1 on page 688 for channel assignments.
19:16	CH12SEL	RW	0x00	μDMA Channel 12 Source Select See Table 9-1 on page 688 for channel assignments.
15:12	CH11SEL	RW	0x00	μDMA Channel 11 Source Select See Table 9-1 on page 688 for channel assignments.
11:8	CH10SEL	RW	0x00	μDMA Channel 10 Source Select See Table 9-1 on page 688 for channel assignments.
7:4	CH9SEL	RW	0x00	μDMA Channel 9 Source Select See Table 9-1 on page 688 for channel assignments.
3:0	CH8SEL	RW	0x00	μDMA Channel 8 Source Select See Table 9-1 on page 688 for channel assignments.

Register 24: DMA Channel Map Select 2 (DMACHMAP2), offset 0x518

Each 4-bit field of the **DMACHMAP2** register configures the μ DMA channel assignment as specified in Table 9-1 on page 688.

Note: To support legacy software which uses the **DMA Channel Assignment (DMACHASGN)** register, a value of 0x0 is equivalent to a **DMACHASGN** bit being clear, and a value of 0x1 is equivalent to a **DMACHASGN** bit being set.

DMA Channel Map Select 2 (DMACHMAP2)

Base 0x400F.F000
Offset 0x518
Type RW, reset 0x0000.0000

	31	30	29	28	27	26	25	24	23	22	21	20	19	18	17	16
	CH23SEL				CH22SEL				CH21SEL				CH20SEL			
Type	RW	RW	RW	RW	RW	RW	RW	RW	RW	RW	RW	RW	RW	RW	RW	RW
Reset	0	0	0	0	0	0	0	0	0	0	0	0	0	0	0	0
	15	14	13	12	11	10	9	8	7	6	5	4	3	2	1	0
	CH19SEL				CH18SEL				CH17SEL				CH16SEL			
Type	RW	RW	RW	RW	RW	RW	RW	RW	RW	RW	RW	RW	RW	RW	RW	RW
Reset	0	0	0	0	0	0	0	0	0	0	0	0	0	0	0	0

Bit/Field	Name	Type	Reset	Description
31:28	CH23SEL	RW	0x00	μ DMA Channel 23 Source Select See Table 9-1 on page 688 for channel assignments.
27:24	CH22SEL	RW	0x00	μ DMA Channel 22 Source Select See Table 9-1 on page 688 for channel assignments.
23:20	CH21SEL	RW	0x00	μ DMA Channel 21 Source Select See Table 9-1 on page 688 for channel assignments.
19:16	CH20SEL	RW	0x00	μ DMA Channel 20 Source Select See Table 9-1 on page 688 for channel assignments.
15:12	CH19SEL	RW	0x00	μ DMA Channel 19 Source Select See Table 9-1 on page 688 for channel assignments.
11:8	CH18SEL	RW	0x00	μ DMA Channel 18 Source Select See Table 9-1 on page 688 for channel assignments.
7:4	CH17SEL	RW	0x00	μ DMA Channel 17 Source Select See Table 9-1 on page 688 for channel assignments.
3:0	CH16SEL	RW	0x00	μ DMA Channel 16 Source Select See Table 9-1 on page 688 for channel assignments.

Register 25: DMA Channel Map Select 3 (DMACHMAP3), offset 0x51C

Each 4-bit field of the **DMACHMAP3** register configures the μ DMA channel assignment as specified in Table 9-1 on page 688.

Note: To support legacy software which uses the **DMA Channel Assignment (DMACHASGN)** register, a value of 0x0 is equivalent to a **DMACHASGN** bit being clear, and a value of 0x1 is equivalent to a **DMACHASGN** bit being set.

DMA Channel Map Select 3 (DMACHMAP3)

Base 0x400F.F000
Offset 0x51C
Type RW, reset 0x0000.0000

	31	30	29	28	27	26	25	24	23	22	21	20	19	18	17	16
	CH31SEL				CH30SEL				CH29SEL				CH28SEL			
Type	RW	RW	RW	RW	RW	RW	RW	RW	RW	RW	RW	RW	RW	RW	RW	RW
Reset	0	0	0	0	0	0	0	0	0	0	0	0	0	0	0	0
	15	14	13	12	11	10	9	8	7	6	5	4	3	2	1	0
	CH27SEL				CH26SEL				CH25SEL				CH24SEL			
Type	RW	RW	RW	RW	RW	RW	RW	RW	RW	RW	RW	RW	RW	RW	RW	RW
Reset	0	0	0	0	0	0	0	0	0	0	0	0	0	0	0	0

Bit/Field	Name	Type	Reset	Description
31:28	CH31SEL	RW	0x00	μ DMA Channel 31 Source Select See Table 9-1 on page 688 for channel assignments.
27:24	CH30SEL	RW	0x00	μ DMA Channel 30 Source Select See Table 9-1 on page 688 for channel assignments.
23:20	CH29SEL	RW	0x00	μ DMA Channel 29 Source Select See Table 9-1 on page 688 for channel assignments.
19:16	CH28SEL	RW	0x00	μ DMA Channel 28 Source Select See Table 9-1 on page 688 for channel assignments.
15:12	CH27SEL	RW	0x00	μ DMA Channel 27 Source Select See Table 9-1 on page 688 for channel assignments.
11:8	CH26SEL	RW	0x00	μ DMA Channel 26 Source Select See Table 9-1 on page 688 for channel assignments.
7:4	CH25SEL	RW	0x00	μ DMA Channel 25 Source Select See Table 9-1 on page 688 for channel assignments.
3:0	CH24SEL	RW	0x00	μ DMA Channel 24 Source Select See Table 9-1 on page 688 for channel assignments.

Register 26: DMA Peripheral Identification 0 (DMAPeriphID0), offset 0xFE0

The **DMAPeriphIDn** registers are hard-coded, and the fields within the registers determine the reset values.

DMA Peripheral Identification 0 (DMAPeriphID0)

Base 0x400F.F000

Offset 0xFE0

Type RO, reset 0x0000.0030

	31	30	29	28	27	26	25	24	23	22	21	20	19	18	17	16
	reserved															
Type	RO	RO	RO	RO	RO	RO	RO	RO	RO	RO	RO	RO	RO	RO	RO	RO
Reset	0	0	0	0	0	0	0	0	0	0	0	0	0	0	0	0
	15	14	13	12	11	10	9	8	7	6	5	4	3	2	1	0
	reserved								PID0							
Type	RO	RO	RO	RO	RO	RO	RO	RO	RO	RO	RO	RO	RO	RO	RO	RO
Reset	0	0	0	0	0	0	0	0	0	0	1	1	0	0	0	0

Bit/Field	Name	Type	Reset	Description
31:8	reserved	RO	0x0000.00	Software should not rely on the value of a reserved bit. To provide compatibility with future products, the value of a reserved bit should be preserved across a read-modify-write operation.
7:0	PID0	RO	0x30	μDMA Peripheral ID Register [7:0] Can be used by software to identify the presence of this peripheral.

Register 27: DMA Peripheral Identification 1 (DMAPeriphID1), offset 0xFE4

The **DMAPeriphIDn** registers are hard-coded, and the fields within the registers determine the reset values.

DMA Peripheral Identification 1 (DMAPeriphID1)

Base 0x400F.F000
 Offset 0xFE4
 Type RO, reset 0x0000.00B2

	31	30	29	28	27	26	25	24	23	22	21	20	19	18	17	16
	reserved															
Type	RO	RO	RO	RO	RO	RO	RO	RO	RO	RO	RO	RO	RO	RO	RO	RO
Reset	0	0	0	0	0	0	0	0	0	0	0	0	0	0	0	0
	15	14	13	12	11	10	9	8	7	6	5	4	3	2	1	0
	reserved								PID1							
Type	RO	RO	RO	RO	RO	RO	RO	RO	RO	RO	RO	RO	RO	RO	RO	RO
Reset	0	0	0	0	0	0	0	0	1	0	1	1	0	0	1	0

Bit/Field	Name	Type	Reset	Description
31:8	reserved	RO	0x0000.00	Software should not rely on the value of a reserved bit. To provide compatibility with future products, the value of a reserved bit should be preserved across a read-modify-write operation.
7:0	PID1	RO	0xB2	μ DMA Peripheral ID Register [15:8] Can be used by software to identify the presence of this peripheral.

Register 28: DMA Peripheral Identification 2 (DMAPeriphID2), offset 0xFE8

The **DMAPeriphIDn** registers are hard-coded, and the fields within the registers determine the reset values.

DMA Peripheral Identification 2 (DMAPeriphID2)

Base 0x400F.F000

Offset 0xFE8

Type RO, reset 0x0000.000B

	31	30	29	28	27	26	25	24	23	22	21	20	19	18	17	16
	reserved															
Type	RO	RO	RO	RO	RO	RO	RO	RO	RO	RO	RO	RO	RO	RO	RO	RO
Reset	0	0	0	0	0	0	0	0	0	0	0	0	0	0	0	0
	15	14	13	12	11	10	9	8	7	6	5	4	3	2	1	0
	reserved								PID2							
Type	RO	RO	RO	RO	RO	RO	RO	RO	RO	RO	RO	RO	RO	RO	RO	RO
Reset	0	0	0	0	0	0	0	0	0	0	0	0	1	0	1	1

Bit/Field	Name	Type	Reset	Description
31:8	reserved	RO	0x0000.00	Software should not rely on the value of a reserved bit. To provide compatibility with future products, the value of a reserved bit should be preserved across a read-modify-write operation.
7:0	PID2	RO	0x0B	μDMA Peripheral ID Register [23:16] Can be used by software to identify the presence of this peripheral.

Register 29: DMA Peripheral Identification 3 (DMAPeriphID3), offset 0xFEC

The **DMAPeriphIDn** registers are hard-coded and the fields within the registers determine the reset values.

DMA Peripheral Identification 3 (DMAPeriphID3)

Base 0x400F.F000
 Offset 0xFEC
 Type RO, reset 0x0000.0000

	31	30	29	28	27	26	25	24	23	22	21	20	19	18	17	16
	reserved															
Type	RO	RO	RO	RO	RO	RO	RO	RO	RO	RO	RO	RO	RO	RO	RO	RO
Reset	0	0	0	0	0	0	0	0	0	0	0	0	0	0	0	0
	15	14	13	12	11	10	9	8	7	6	5	4	3	2	1	0
	reserved								PID3							
Type	RO	RO	RO	RO	RO	RO	RO	RO	RO	RO	RO	RO	RO	RO	RO	RO
Reset	0	0	0	0	0	0	0	0	0	0	0	0	0	0	0	0

Bit/Field	Name	Type	Reset	Description
31:8	reserved	RO	0x0000.00	Software should not rely on the value of a reserved bit. To provide compatibility with future products, the value of a reserved bit should be preserved across a read-modify-write operation.
7:0	PID3	RO	0x00	μ DMA Peripheral ID Register [31:24] Can be used by software to identify the presence of this peripheral.

Register 30: DMA Peripheral Identification 4 (DMAPeriphID4), offset 0xFD0

The **DMAPeriphIDn** registers are hard-coded, and the fields within the registers determine the reset values.

DMA Peripheral Identification 4 (DMAPeriphID4)

Base 0x400F.F000

Offset 0xFD0

Type RO, reset 0x0000.0004

	31	30	29	28	27	26	25	24	23	22	21	20	19	18	17	16
	reserved															
Type	RO	RO	RO	RO	RO	RO	RO	RO	RO	RO	RO	RO	RO	RO	RO	RO
Reset	0	0	0	0	0	0	0	0	0	0	0	0	0	0	0	0
	15	14	13	12	11	10	9	8	7	6	5	4	3	2	1	0
	reserved								PID4							
Type	RO	RO	RO	RO	RO	RO	RO	RO	RO	RO	RO	RO	RO	RO	RO	RO
Reset	0	0	0	0	0	0	0	0	0	0	0	0	0	1	0	0

Bit/Field	Name	Type	Reset	Description
31:8	reserved	RO	0x0000.00	Software should not rely on the value of a reserved bit. To provide compatibility with future products, the value of a reserved bit should be preserved across a read-modify-write operation.
7:0	PID4	RO	0x04	μDMA Peripheral ID Register Can be used by software to identify the presence of this peripheral.

Register 31: DMA PrimeCell Identification 0 (DMAPCellID0), offset 0xFF0

The **DMAPCellIDn** registers are hard-coded, and the fields within the registers determine the reset values.

DMA PrimeCell Identification 0 (DMAPCellID0)

Base 0x400F.F000
 Offset 0xFF0
 Type RO, reset 0x0000.000D

	31	30	29	28	27	26	25	24	23	22	21	20	19	18	17	16
	reserved															
Type	RO	RO	RO	RO	RO	RO	RO	RO	RO	RO	RO	RO	RO	RO	RO	RO
Reset	0	0	0	0	0	0	0	0	0	0	0	0	0	0	0	0
	15	14	13	12	11	10	9	8	7	6	5	4	3	2	1	0
	reserved								CID0							
Type	RO	RO	RO	RO	RO	RO	RO	RO	RO	RO	RO	RO	RO	RO	RO	RO
Reset	0	0	0	0	0	0	0	0	0	0	0	0	1	1	0	1

Bit/Field	Name	Type	Reset	Description
31:8	reserved	RO	0x0000.00	Software should not rely on the value of a reserved bit. To provide compatibility with future products, the value of a reserved bit should be preserved across a read-modify-write operation.
7:0	CID0	RO	0x0D	μ DMA PrimeCell ID Register [7:0] Provides software a standard cross-peripheral identification system.

Register 32: DMA PrimeCell Identification 1 (DMAPCellID1), offset 0xFF4

The **DMAPCellIDn** registers are hard-coded, and the fields within the registers determine the reset values.

DMA PrimeCell Identification 1 (DMAPCellID1)

Base 0x400F.F000

Offset 0xFF4

Type RO, reset 0x0000.00F0

	31	30	29	28	27	26	25	24	23	22	21	20	19	18	17	16
	reserved															
Type	RO	RO	RO	RO	RO	RO	RO	RO	RO	RO	RO	RO	RO	RO	RO	RO
Reset	0	0	0	0	0	0	0	0	0	0	0	0	0	0	0	0
	15	14	13	12	11	10	9	8	7	6	5	4	3	2	1	0
	reserved								CID1							
Type	RO	RO	RO	RO	RO	RO	RO	RO	RO	RO	RO	RO	RO	RO	RO	RO
Reset	0	0	0	0	0	0	0	0	1	1	1	1	0	0	0	0

Bit/Field	Name	Type	Reset	Description
31:8	reserved	RO	0x0000.00	Software should not rely on the value of a reserved bit. To provide compatibility with future products, the value of a reserved bit should be preserved across a read-modify-write operation.
7:0	CID1	RO	0xF0	μDMA PrimeCell ID Register [15:8] Provides software a standard cross-peripheral identification system.

Register 33: DMA PrimeCell Identification 2 (DMAPCellID2), offset 0xFF8

The **DMAPCellIDn** registers are hard-coded, and the fields within the registers determine the reset values.

DMA PrimeCell Identification 2 (DMAPCellID2)

Base 0x400F.F000
 Offset 0xFF8
 Type RO, reset 0x0000.0005

	31	30	29	28	27	26	25	24	23	22	21	20	19	18	17	16
	reserved															
Type	RO	RO	RO	RO	RO	RO	RO	RO	RO	RO	RO	RO	RO	RO	RO	RO
Reset	0	0	0	0	0	0	0	0	0	0	0	0	0	0	0	0
	15	14	13	12	11	10	9	8	7	6	5	4	3	2	1	0
	reserved								CID2							
Type	RO	RO	RO	RO	RO	RO	RO	RO	RO	RO	RO	RO	RO	RO	RO	RO
Reset	0	0	0	0	0	0	0	0	0	0	0	0	0	1	0	1

Bit/Field	Name	Type	Reset	Description
31:8	reserved	RO	0x00	Software should not rely on the value of a reserved bit. To provide compatibility with future products, the value of a reserved bit should be preserved across a read-modify-write operation.
7:0	CID2	RO	0x05	μ DMA PrimeCell ID Register [23:16] Provides software a standard cross-peripheral identification system.

Register 34: DMA PrimeCell Identification 3 (DMAPCellID3), offset 0xFFC

The **DMAPCellIDn** registers are hard-coded, and the fields within the registers determine the reset values.

DMA PrimeCell Identification 3 (DMAPCellID3)

Base 0x400F.F000

Offset 0xFFC

Type RO, reset 0x0000.00B1

	31	30	29	28	27	26	25	24	23	22	21	20	19	18	17	16
	reserved															
Type	RO	RO	RO	RO	RO	RO	RO	RO	RO	RO	RO	RO	RO	RO	RO	RO
Reset	0	0	0	0	0	0	0	0	0	0	0	0	0	0	0	0
	15	14	13	12	11	10	9	8	7	6	5	4	3	2	1	0
	reserved								CID3							
Type	RO	RO	RO	RO	RO	RO	RO	RO	RO	RO	RO	RO	RO	RO	RO	RO
Reset	0	0	0	0	0	0	0	0	1	0	1	1	0	0	0	1

Bit/Field	Name	Type	Reset	Description
31:8	reserved	RO	0x00	Software should not rely on the value of a reserved bit. To provide compatibility with future products, the value of a reserved bit should be preserved across a read-modify-write operation.
7:0	CID3	RO	0xB1	μDMA PrimeCell ID Register [31:24] Provides software a standard cross-peripheral identification system.

10 General-Purpose Input/Outputs (GPIOs)

The GPIO module is composed of 15 physical GPIO blocks, each corresponding to an individual GPIO port (Port A, Port B, Port C, Port D, Port E, Port F, Port G, Port H, Port J, Port K, Port L, Port M, Port N, Port P, Port Q). The GPIO module supports up to 90 programmable input/output pins, depending on the peripherals being used.

The GPIO module has the following features:

- Up to 90 GPIOs, depending on configuration
- Highly flexible pin muxing allows use as GPIO or one of several peripheral functions
- 3.3-V-tolerant in input configuration
- Advanced High Performance Bus accesses all ports:
 - Ports A-H and J; Ports K-N and P-Q
- Fast toggle capable of a change every clock cycle for ports on AHB
- Programmable control for GPIO interrupts
 - Interrupt generation masking
 - Edge-triggered on rising, falling, or both
 - Level-sensitive on High or Low values
 - Per-pin interrupts available on Port P and Port Q
- Bit masking in both read and write operations through address lines
- Can be used to initiate an ADC sample sequence or a μ DMA transfer
- Pin state can be retained during Hibernation mode; pins on port P can be programmed to wake on level in Hibernation mode
- Pins configured as digital inputs are Schmitt-triggered
- Programmable control for GPIO pad configuration
 - Weak pull-up or pull-down resistors
 - 2-mA, 4-mA, 6-mA, 8-mA, 10-mA and 12-mA pad drive for digital communication; up to four pads can sink 18-mA for high-current applications
 - Slew rate control for 8-mA, 10-mA and 12-mA pad drive
 - Open drain enables
 - Digital input enables

10.1 Signal Description

GPIO signals have alternate hardware functions. The following table lists the GPIO pins and their analog and digital alternate functions. The digital alternate hardware functions are enabled by setting the appropriate bit in the **GPIO Alternate Function Select (GPIOAFSEL)** and **GPIO DEN** registers and configuring the PMC_x bit field in the **GPIO Port Control (GPIOPCTL)** register to the numeric encoding shown in the table below. Analog signals in the table below are also 3.3-V tolerant and are configured by clearing the **DEN** bit in the **GPIO Digital Enable (GPIODEN)** register. The A_{INx} analog signals have internal circuitry to protect them from voltages over V_{DD} (up to the maximum specified in Table 30-1 on page 1942), but analog performance specifications are only guaranteed if the input signal swing at the I/O pad is kept inside the range $0\text{ V} < V_{IN} < V_{DD}$. Note that each pin must be programmed individually; no type of grouping is implied by the columns in the table. Table entries that are shaded gray are the default values for the corresponding GPIO pin.

Important: The table below shows special consideration GPIO pins. Most GPIO pins are configured as GPIOs and tri-stated by default (**GPIOAFSEL=0**, **GPIODEN=0**, **GPIOPDR=0**, **GPIOPUR=0**, and **GPIOPCTL=0**). Special consideration pins may be programmed to a non-GPIO function or may have special commit controls out of reset. In addition, a Power-On-Reset (\overline{POR}) returns these GPIO to their original special consideration state.

Table 10-1. GPIO Pins With Special Considerations

GPIO Pins	Default Reset State	GPIOAFSEL	GPIODEN	GPIOPDR	GPIOPUR	GPIOPCTL	GPIOCR
PC[3:0]	JTAG/SWD	1	1	0	1	0x1	0
PD[7]	GPIO ^a	0	0	0	0	0x0	0
PE[7]	GPIO ^a	0	0	0	0	0x0	0

a. This pin is configured as a GPIO by default but is locked and can only be reprogrammed by unlocking the pin in the **GPIOLOCK** register and uncommitting it by setting the **GPIOCR** register.

The GPIO commit control registers provide a layer of protection against accidental programming of critical hardware signals including the GPIO pins that can function as JTAG/SWD signals and the **NMI** signal. The commit control process must be followed for these pins, even if they are programmed as alternate functions other than JTAG/SWD or **NMI**; see “Commit Control” on page 760.

Note: If the device fails initialization during reset, the hardware toggles the **TDO** output as an indication of failure. Thus, during board layout, designers should not designate the **TDO** pin as a GPIO in sensitive applications where the possibility of toggling could affect the design.

Table 10-2. GPIO Pins and Alternate Functions (128TQFP)

IO	Pin	Analog or Special Function ^a	Digital Function (GPIOPCTL PMC_x Bit Field Encoding) ^b											
			1	2	3	4	5	6	7	8	11	13	14	15
PA0	33	-	U0Rx	I2C9SCL	T0CCP0	-	-	-	CAN0Rx	-	-	-	-	-
PA1	34	-	U0Tx	I2C9SDA	T0CCP1	-	-	-	CAN0Tx	-	-	-	-	-
PA2	35	-	U4Rx	I2C8SCL	T1CCP0	-	-	-	-	-	-	-	-	SSI0Clk
PA3	36	-	U4Tx	I2C8SDA	T1CCP1	-	-	-	-	-	-	-	-	SSI0Fss
PA4	37	-	U3Rx	I2C7SCL	T2CCP0	-	-	-	-	-	-	-	-	SSI0XDAT0

Table 10-2. GPIO Pins and Alternate Functions (128TQFP) (continued)

IO	Pin	Analog or Special Function ^a	Digital Function (GPIO PCTL PMCx Bit Field Encoding) ^b											
			1	2	3	4	5	6	7	8	11	13	14	15
PA5	38	-	U3Tx	I2C7SDA	T2CCP1	-	-	-	-	-	-	-	-	SSI0XDAT1
PA6	40	-	U2Rx	I2C6SCL	T3CCP0	-	USB0EPEN	-	-	-	-	SSI0XDAT2	-	EPI0S8
PA7	41	-	U2Tx	I2C6SDA	T3CCP1	-	USB0PFLT	-	-	-	USB0EPEN	SSI0XDAT3	-	EPI0S9
PB0	95	USB0ID	U1Rx	I2C5SCL	T4CCP0	-	-	-	CAN1Rx	-	-	-	-	-
PB1	96	USB0VBUS	U1Tx	I2C5SDA	T4CCP1	-	-	-	CAN1Tx	-	-	-	-	-
PB2	91	-	-	I2C0SCL	T5CCP0	-	-	-	-	-	-	-	USB0STP	EPI0S27
PB3	92	-	-	I2C0SDA	T5CCP1	-	-	-	-	-	-	-	USB0CLK	EPI0S28
PB4	121	AIN10	U0CTS	I2C5SCL	-	-	-	-	-	-	-	-	-	SSI1Fss
PB5	120	AIN11	U0RTS	I2C5SDA	-	-	-	-	-	-	-	-	-	SSI1Clk
PC0	100	-	TCK SWCLK	-	-	-	-	-	-	-	-	-	-	-
PC1	99	-	TMS SWDIO	-	-	-	-	-	-	-	-	-	-	-
PC2	98	-	TDI	-	-	-	-	-	-	-	-	-	-	-
PC3	97	-	TDO SWO	-	-	-	-	-	-	-	-	-	-	-
PC4	25	C1-	U7Rx	-	-	-	-	-	-	-	-	-	-	EPI0S7
PC5	24	C1+	U7Tx	-	-	-	-	-	RTCCLK	-	-	-	-	EPI0S6
PC6	23	C0+	U5Rx	-	-	-	-	-	-	-	-	-	-	EPI0S5
PC7	22	C0-	U5Tx	-	-	-	-	-	-	-	-	-	-	EPI0S4
PD0	1	AIN15	-	I2C7SCL	T0CCP0	-	C0o	-	-	-	-	-	-	SSI2XDAT1
PD1	2	AIN14	-	I2C7SDA	T0CCP1	-	C1o	-	-	-	-	-	-	SSI2XDAT0
PD2	3	AIN13	-	I2C8SCL	T1CCP0	-	C2o	-	-	-	-	-	-	SSI2Fss
PD3	4	AIN12	-	I2C8SDA	T1CCP1	-	-	-	-	-	-	-	-	SSI2Clk
PD4	125	AIN7	U2Rx	-	T3CCP0	-	-	-	-	-	-	-	-	SSI1XDAT2
PD5	126	AIN6	U2Tx	-	T3CCP1	-	-	-	-	-	-	-	-	SSI1XDAT3
PD6	127	AIN5	U2RTS	-	T4CCP0	-	USB0EPEN	-	-	-	-	-	-	SSI2XDAT3
PD7	128	AIN4	U2CTS	-	T4CCP1	-	USB0PFLT	-	-	NMI	-	-	-	SSI2XDAT2
PE0	15	AIN3	U1RTS	-	-	-	-	-	-	-	-	-	-	-
PE1	14	AIN2	U1DSR	-	-	-	-	-	-	-	-	-	-	-
PE2	13	AIN1	U1DCD	-	-	-	-	-	-	-	-	-	-	-
PE3	12	AIN0	U1DTR	-	-	-	-	-	-	-	-	-	-	-
PE4	123	AIN9	U1RI	-	-	-	-	-	-	-	-	-	-	SSI1XDAT0
PE5	124	AIN8	-	-	-	-	-	-	-	-	-	-	-	SSI1XDAT1
PF0	42	-	-	-	-	-	ENOLED0	MOPWM0	-	-	-	-	SSI3XDAT1	TRD2
PF1	43	-	-	-	-	-	ENOLED2	MOPWM1	-	-	-	-	SSI3XDAT0	TRD1

Table 10-2. GPIO Pins and Alternate Functions (128TQFP) (continued)

IO	Pin	Analog or Special Function ^a	Digital Function (GPIOCTL PMCx Bit Field Encoding) ^b												
			1	2	3	4	5	6	7	8	11	13	14	15	
PF2	44	-	-	-	-	-	-	-	M0PWM2	-	-	-	-	SSI3Fss	TRD0
PF3	45	-	-	-	-	-	-	-	M0PWM3	-	-	-	-	SSI3Clk	TRCLK
PF4	46	-	-	-	-	-	-	ENOLED1	M0FAULT0	-	-	-	-	SSI3XDAT2	TRD3
PG0	49	-	-	I2C1SCL	-	-	-	ENOPPS	M0PWM4	-	-	-	-	-	EPI0S11
PG1	50	-	-	I2C1SDA	-	-	-	-	M0PWM5	-	-	-	-	-	EPI0S10
PH0	29	-	U0RTS	-	-	-	-	-	-	-	-	-	-	-	EPI0S0
PH1	30	-	U0CTS	-	-	-	-	-	-	-	-	-	-	-	EPI0S1
PH2	31	-	U0DCD	-	-	-	-	-	-	-	-	-	-	-	EPI0S2
PH3	32	-	U0DSR	-	-	-	-	-	-	-	-	-	-	-	EPI0S3
PJ0	116	-	U3Rx	-	-	-	-	ENOPPS	-	-	-	-	-	-	-
PJ1	117	-	U3Tx	-	-	-	-	-	-	-	-	-	-	-	-
PK0	18	AIN16	U4Rx	-	-	-	-	-	-	-	-	-	-	-	EPI0S0
PK1	19	AIN17	U4Tx	-	-	-	-	-	-	-	-	-	-	-	EPI0S1
PK2	20	AIN18	U4RTS	-	-	-	-	-	-	-	-	-	-	-	EPI0S2
PK3	21	AIN19	U4CTS	-	-	-	-	-	-	-	-	-	-	-	EPI0S3
PK4	63	-	-	I2C3SCL	-	-	-	ENOLED0	M0PWM6	-	-	-	-	-	EPI0S32
PK5	62	-	-	I2C3SDA	-	-	-	ENOLED2	M0PWM7	-	-	-	-	-	EPI0S31
PK6	61	-	-	I2C4SCL	-	-	-	ENOLED1	M0FAULT1	-	-	-	-	-	EPI0S25
PK7	60	-	U0RI	I2C4SDA	-	-	-	RTCCLK	M0FAULT2	-	-	-	-	-	EPI0S24
PL0	81	-	-	I2C2SDA	-	-	-	-	M0FAULT3	-	-	-	-	USB0D0	EPI0S16
PL1	82	-	-	I2C2SCL	-	-	-	-	PhA0	-	-	-	-	USB0D1	EPI0S17
PL2	83	-	-	-	-	-	-	C0o	PhB0	-	-	-	-	USB0D2	EPI0S18
PL3	84	-	-	-	-	-	-	C1o	IDX0	-	-	-	-	USB0D3	EPI0S19
PL4	85	-	-	-	-	T0CCP0	-	-	-	-	-	-	-	USB0D4	EPI0S26
PL5	86	-	-	-	-	T0CCP1	-	-	-	-	-	-	-	USB0D5	EPI0S33
PL6	94	USB0DP	-	-	-	T1CCP0	-	-	-	-	-	-	-	-	-
PL7	93	USB0DM	-	-	-	T1CCP1	-	-	-	-	-	-	-	-	-
PM0	78	-	-	-	-	T2CCP0	-	-	-	-	-	-	-	-	EPI0S15
PM1	77	-	-	-	-	T2CCP1	-	-	-	-	-	-	-	-	EPI0S14
PM2	76	-	-	-	-	T3CCP0	-	-	-	-	-	-	-	-	EPI0S13
PM3	75	-	-	-	-	T3CCP1	-	-	-	-	-	-	-	-	EPI0S12
PM4	74	TMPR3	U0CTS	-	-	T4CCP0	-	-	-	-	-	-	-	-	-
PM5	73	TMPR2	U0DCD	-	-	T4CCP1	-	-	-	-	-	-	-	-	-
PM6	72	TMPR1	U0DSR	-	-	T5CCP0	-	-	-	-	-	-	-	-	-

Table 10-2. GPIO Pins and Alternate Functions (128TQFP) (continued)

IO	Pin	Analog or Special Function ^a	Digital Function (GPIO PCTL PMCx Bit Field Encoding) ^b											
			1	2	3	4	5	6	7	8	11	13	14	15
PM7	71	TMPR0	U0RI	-	T5CCP1	-	-	-	-	-	-	-	-	-
PN0	107	-	U1RTS	-	-	-	-	-	-	-	-	-	-	-
PN1	108	-	U1CTS	-	-	-	-	-	-	-	-	-	-	-
PN2	109	-	U1DCD	U2RTS	-	-	-	-	-	-	-	-	-	EPI0S29
PN3	110	-	U1DSR	U2CTS	-	-	-	-	-	-	-	-	-	EPI0S30
PN4	111	-	U1DTR	U3RTS	I2C2SDA	-	-	-	-	-	-	-	-	EPI0S34
PN5	112	-	U1RI	U3CTS	I2C2SCL	-	-	-	-	-	-	-	-	EPI0S35
PP0	118	C2+	U6Rx	-	-	-	-	-	-	-	-	-	-	SSI3XDAT2
PP1	119	C2-	U6Tx	-	-	-	-	-	-	-	-	-	-	SSI3XDAT3
PP2	103	-	U0DTR	-	-	-	-	-	-	-	-	-	USB0NXT	EPI0S29
PP3	104	-	U1CTS	U0DCD	-	-	-	-	RTCCLK	-	-	-	USB0DIR	EPI0S30
PP4	105	-	U3RTS	U0DSR	-	-	-	-	-	-	-	-	USB0D7	-
PP5	106	-	U3CTS	I2C2SCL	-	-	-	-	-	-	-	-	USB0D6	-
PQ0	5	-	-	-	-	-	-	-	-	-	-	-	SSI3Clk	EPI0S20
PQ1	6	-	-	-	-	-	-	-	-	-	-	-	SSI3Fss	EPI0S21
PQ2	11	-	-	-	-	-	-	-	-	-	-	-	SSI3DAT0	EPI0S22
PQ3	27	-	-	-	-	-	-	-	-	-	-	-	SSI3DAT1	EPI0S23
PQ4	102	-	U1Rx	-	-	-	-	-	DIVSCLK	-	-	-	-	-

a. The TMPRn signals are digital signals enabled and configured by the Hibernation module. All other signals listed in this column are analog signals.

b. The digital signals that are shaded gray are the power-on default values for the corresponding GPIO pin. Encodings 9, 10, and 12 are not used on this device.

10.2 Pad Capabilities

There are two main types of pads provided on the device:

- Fast GPIO pads: These pads provide variable, programmable drive strength and optimized voltage output levels.
- Slow GPIO pads: These pads provide 2-mA drive strength and are designed to be sensitive to voltage inputs. The following GPIOs port pins are designed with Slow GPIO Pads:
 - PJ1

Please refer to “Recommended GPIO Operating Characteristics” on page 1944 for details on the GPIO operating conditions for these two different pad types.

Note: Port pins **PL6** and **PL7** operate as Fast GPIO pads, but have 4-mA drive capability only. GPIO register controls for drive strength, slew rate and open drain have no effect on these pins. The registers which have no effect are as follows: **GPIODR2R**, **GPIODR4R**, **GPIODR8R**, **GPIODR12R**, **GPIOSLR**, and **GPIOODR**.

Note: Port pins $PM[7:4]$ operate as Fast GPIO pads but support only 2-, 4-, 6-, and 8-mA drive capability. 10- and 12-mA drive are not supported. All standard GPIO register controls, except for the **GPIODR12R** register, apply to these port pins.

10.3 Functional Description

Each GPIO port is a separate hardware instantiation of the same physical block (see Figure 10-1 on page 755 and Figure 10-2 on page 756). The TM4C129ENCPDT microcontroller contains 15 ports and thus 15 of these physical GPIO blocks. Note that not all pins are implemented on every block. Some GPIO pins can function as I/O signals for the on-chip peripheral modules. For information on which GPIO pins are used for alternate hardware functions, refer to Table 29-5 on page 1932.

Figure 10-1. Digital I/O Pads

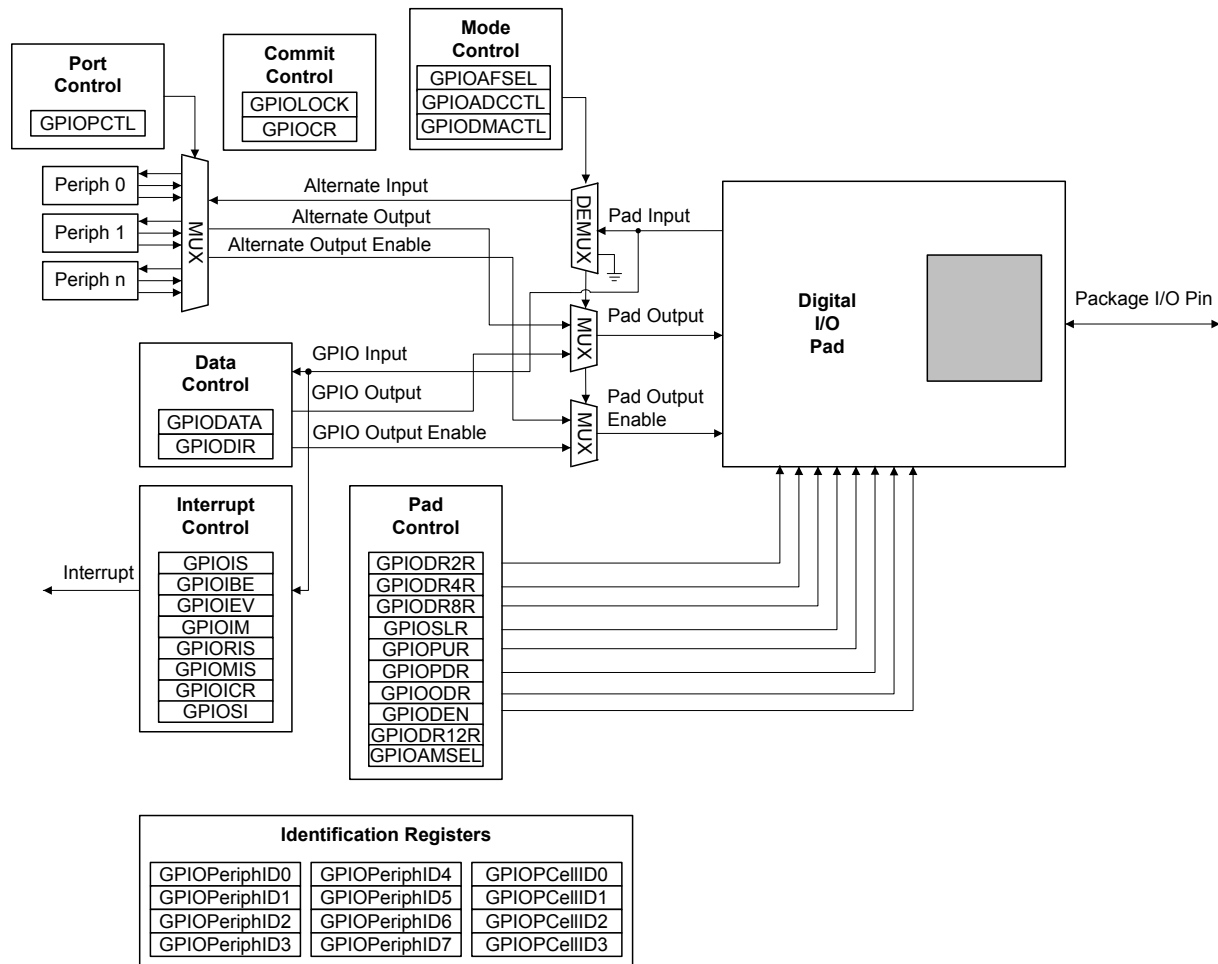
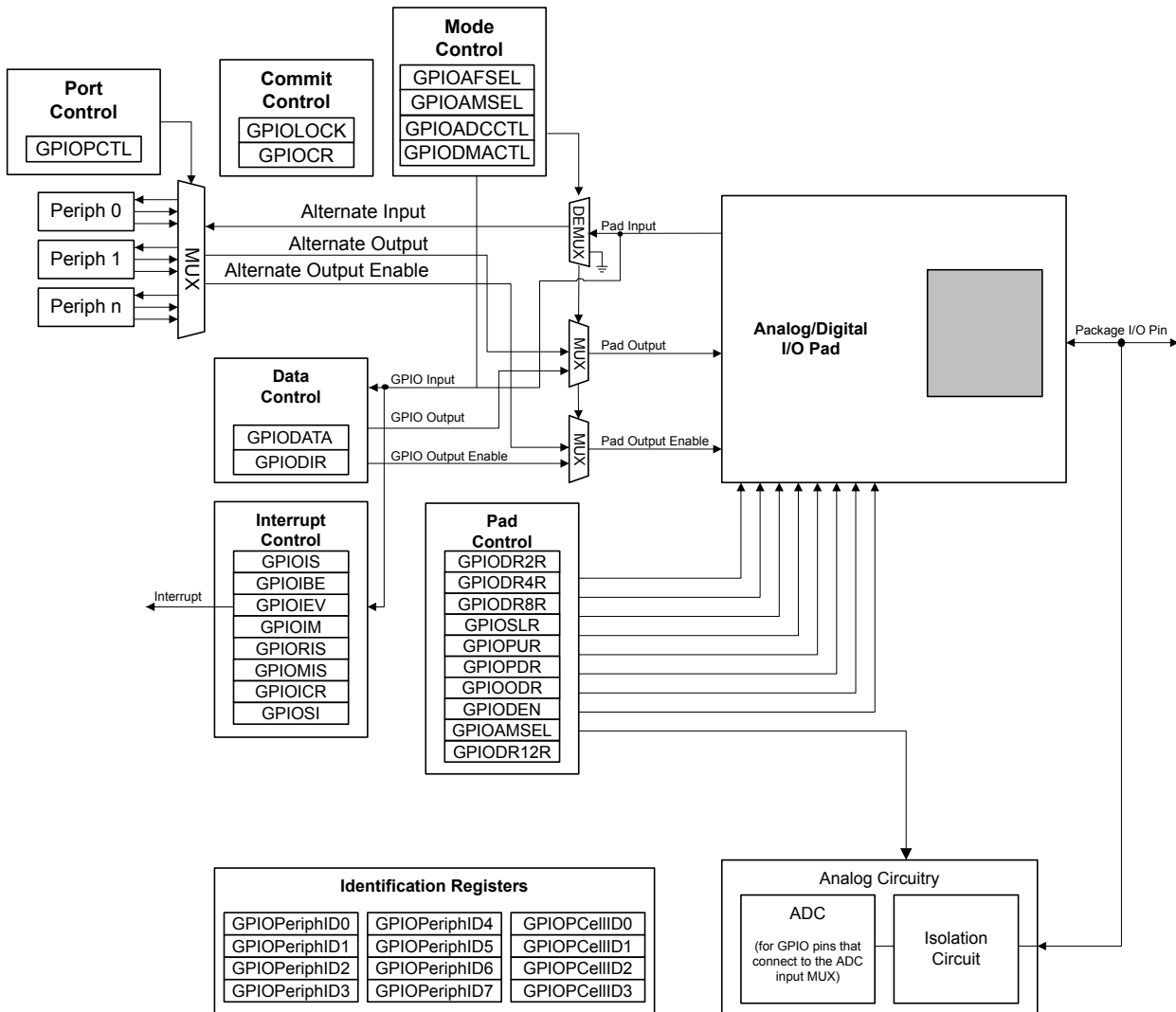

Figure 10-2. Analog/Digital I/O Pads



10.3.1 Data Control

The data control registers allow software to configure the operational modes of the GPIOs. The data direction register configures the GPIO as an input or an output while the data register either captures incoming data or drives it out to the pads.

Caution – It is possible to create a software sequence that prevents the debugger from connecting to the TM4C129ENC PDT microcontroller. If the program code loaded into flash immediately changes the JTAG pins to their GPIO functionality, the debugger may not have enough time to connect and halt the controller before the JTAG pin functionality switches. As a result, the debugger may be locked out of the part. This issue can be avoided with a software routine that restores JTAG functionality based on an external or software trigger. In the case that the software routine is not implemented and the device is locked out of the part, this issue can be solved by using the TM4C129ENC PDT Flash Programmer "Unlock" feature. Please refer to [LMFLASHPROGRAMMER](#) on the TI web for more information.

10.3.1.1 Data Direction Operation

The **GPIO Direction (GPIODIR)** register (see page 768) is used to configure each individual pin as an input or output. When the data direction bit is cleared, the GPIO is configured as an input, and the corresponding data register bit captures and stores the value on the GPIO port. When the data direction bit is set, the GPIO is configured as an output, and the corresponding data register bit is driven out on the GPIO port.

10.3.1.2 Data Register Operation

To aid in the efficiency of software, the GPIO ports allow for the modification of individual bits in the **GPIO Data (GPIODATA)** register (see page 767) by using bits [9:2] of the address bus as a mask. In this manner, software drivers can modify individual GPIO pins in a single instruction without affecting the state of the other pins. This method is more efficient than the conventional method of performing a read-modify-write operation to set or clear an individual GPIO pin. To implement this feature, the **GPIODATA** register covers 256 locations in the memory map.

During a write, if the address bit associated with that data bit is set, the value of the **GPIODATA** register is altered. If the address bit is cleared, the data bit is left unchanged.

For example, writing a value of 0xEB to the address GPIODATA + 0x098 has the results shown in Figure 10-3, where u indicates that data is unchanged by the write. This example demonstrates how **GPIODATA** bits 5, 2, and 1 are written.

Figure 10-3. GPIODATA Write Example

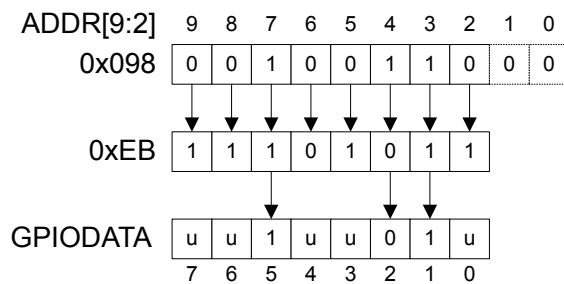

During a read, if the address bit associated with the data bit is set, the value is read. If the address bit associated with the data bit is cleared, the data bit is read as a zero, regardless of its actual value. For example, reading address GPIODATA + 0x0C4 yields as shown in Figure 10-4. This example shows how to read **GPIODATA** bits 5, 4, and 0.

Figure 10-4. GPIODATA Read Example

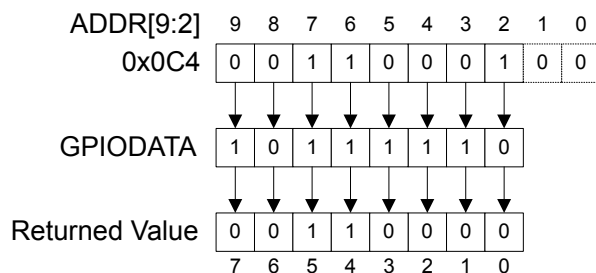

10.3.2 Interrupt Control

The interrupt capabilities of each GPIO port are controlled by a set of seven registers. These registers are used to select the source of the interrupt, its polarity, and the edge properties. When one or more GPIO inputs cause an interrupt, a single interrupt output is sent to the interrupt controller for the entire GPIO port. For edge-triggered interrupts, software must clear the interrupt to enable any further interrupts. For a level-sensitive interrupt, the external source must hold the level constant for the interrupt to be recognized by the controller.

Three registers define the edge or sense that causes interrupts:

- **GPIO Interrupt Sense (GPIOIS)** register (see page 769)
- **GPIO Interrupt Both Edges (GPIOIBE)** register (see page 770)
- **GPIO Interrupt Event (GPIOIEV)** register (see page 771)

Interrupts are enabled/disabled via the **GPIO Interrupt Mask (GPIOIM)** register (see page 772).

When an interrupt condition occurs, the state of the interrupt signal can be viewed in two locations: the **GPIO Raw Interrupt Status (GPIORIS)** and **GPIO Masked Interrupt Status (GPIOMIS)** registers (see page 773 and page 775). As the name implies, the **GPIOMIS** register only shows interrupt conditions that are allowed to be passed to the interrupt controller. The **GPIORIS** register indicates that a GPIO pin meets the conditions for an interrupt, but has not necessarily been sent to the interrupt controller.

For a GPIO level-detect interrupt, the interrupt signal generating the interrupt must be held until serviced. Once the input signal deasserts from the interrupt generating logical sense, the corresponding **RIS** bit in the **GPIORIS** register clears. For a GPIO edge-detect interrupt, the **RIS** bit in the **GPIORIS** register is cleared by writing a '1' to the corresponding bit in the **GPIO Interrupt Clear (GPIOICR)** register (see page 777). The corresponding **GPIOMIS** bit reflects the masked value of the **RIS** bit.

When programming the interrupt control registers (**GPIOIS**, **GPIOIBE**, or **GPIOIEV**), the interrupts should be masked (**GPIOIM** cleared). Writing any value to an interrupt control register can generate a spurious interrupt if the corresponding bits are enabled.

10.3.2.1 Interrupts Per Pin

Each pin of GPIO Port P and Port Q can trigger an interrupt. Each pin has a dedicated interrupt vector and can be handled by a separate interrupt handler. The **PP0** and **PQ0** interrupts serve as a master interrupt and provide a legacy aggregated interrupt version. For interrupt assignments, see Table 2-9 on page 122.

Note: The OR'ed summary interrupt occurs on bit 0 of the **GPIORIS** register. For summary interrupt mode, software should set the **GPIOIM** register to 0xFF and mask the port pin interrupts 1 through 7 in the **Interrupt Clear Enable (DISn)** register (see "NVIC Register Descriptions" on page 160). When servicing this interrupt, write a 1 to the corresponding bit in the **UNPENDn** register to clear the pending interrupt in the NVIC and clear the **GPIORIS** register pin interrupt bits by setting the **IC** field of the **GPIOICR** register to 0xFF.

10.3.2.2 ADC Trigger Source

Any GPIO pin can be configured to be an external trigger for the ADC using the **GPIO ADC Control (GPIOADCCTL)** register. If any GPIO is configured as a non-masked interrupt pin (the appropriate bit of **GPIOIM** is set), and an interrupt for that port is generated, a trigger signal is sent to the ADC. If the **ADC Event Multiplexer Select (ADCEMUX)** register is configured to use the external trigger,

an ADC conversion is initiated. See page 1215. Note that whether the GPIO is configured to trigger on edge events or level events, a single-clock ADC trigger pulse is created in either event. Thus, when a level event is selected, the ADC sample sequence will run only one time and multiple sample sequences will not be executed if the level remains the same. It is recommended that edge events be used as ADC trigger source.

Note that if the Port B **GPIOADCCTL** register is cleared, PB4 can still be used as an external trigger for the ADC. This is a legacy mode which allows code written for previous devices to operate on this microcontroller.

10.3.2.3 μ DMA Trigger Source

Any GPIO pin can be configured to be an external trigger for the μ DMA using the **GPIO DMA Control (GPIODMACTL)** register. If any GPIO is configured as a non-masked interrupt pin (the appropriate bit of **GPIOIM** is set), a `dma_req` signal is sent to the μ DMA. If the μ DMA is configured to start a transfer based on the GPIO signal, a transfer is initiated. When transfer is complete, the `dma_done` signal is sent from the μ DMA to the GPIO and is reported as a DMA (done) interrupt in the **GPIOISR** register.

10.3.2.4 HIB Wake Source

GPIO pins K[7:4] on Port K can be configured as an external wake source for the hibernation (HIB) module. The pins can be configured in the following way:

1. Write 0x0000.0040 to the **HIBCTL** register at offset 0x010 to enable 32.768-kHz Hibernation oscillator.
2. Write any data to be retained during power cut to the **HIBDATA** register at offsets 0x030-0x06F.
3. Configure the **GPIOWAKEPEN** and **GPIOWAKELVL** registers at offsets 0x540 and 0x544 in the GPIO module. Enable the I/O wake pad configuration by writing 0x0000.0001 to the **HIBIO** register at offset 0x010.
4. When the **IOWRC** bit in the **HIBIO** register is read as 1, write 0x0000.0000 to the **HIBIO** register to lock the current pad configuration so that any other writes to the **GPIOWAKEPEN** and **GPIOWAKELVL** register will be ignored.
5. The hibernation sequence may be initiated by writing 0x0000.0052 to the **HIBCTL** register.

The **GPIOWAKESTAT** register at offset 0x548 can be read to determine which port caused a wake pin assertion.

10.3.3 Mode Control

The GPIO pins can be controlled by either software or hardware. Software control is the default for most signals and corresponds to the GPIO mode, where the **GPIODATA** register is used to read or write the corresponding pins. When hardware control is enabled via the **GPIO Alternate Function Select (GPIOAFSEL)** register (see page 778), the pin state is controlled by its alternate function (that is, the peripheral).

Further pin muxing options are provided through the **GPIO Port Control (GPIOPCTL)** register which selects one of several peripheral functions for each GPIO. For information on the configuration options, refer to Table 29-5 on page 1932.

Note: If any pin is to be used as an ADC input, the appropriate bit in the **GPIOAMSEL** register must be set to disable the analog isolation circuit.

10.3.4 Commit Control

The GPIO commit control registers provide a layer of protection against accidental programming of critical hardware peripherals. Protection is provided for the GPIO pins that can be used as the four JTAG/SWD pins and the NMI pin (see “Signal Tables” on page 1896 for pin numbers). Writes to protected bits of the **GPIO Alternate Function Select (GPIOAFSEL)** register (see page 778), **GPIO Pull Up Select (GPIOPUR)** register (see page 784), **GPIO Pull-Down Select (GPIOPDR)** register (see page 786), and **GPIO Digital Enable (GPIODEN)** register (see page 789) are not committed to storage unless the **GPIO Lock (GPIOLCK)** register (see page 791) has been unlocked and the appropriate bits of the **GPIO Commit (GPIOCR)** register (see page 792) have been set.

10.3.5 Pad Control

The pad control registers allow software to configure the GPIO pads based on the application requirements. The pad control registers include the **GPIODR2R**, **GPIODR4R**, **GPIODR8R**, **GPIODR12R**, **GPIODR**, **GPIOPUR**, **GPIOPDR**, **GPIOSLR**, and **GPIODEN** registers. These registers control drive strength, open-drain configuration, pull-up and pull-down resistors, slew-rate control and digital input enable for each GPIO. If 3.3V is applied to a GPIO configured as an open-drain output, the output voltage will depend on the strength of your pull-up resistor. The GPIO pad is not electrically configured to output 3.3 V.

Note: Port pins **PL6** and **PL7** operate as Fast GPIO pads, but have 4-mA drive capability only. GPIO register controls for drive strength, slew rate and open drain have no effect on these pins. The registers which have no effect are as follows: **GPIODR2R**, **GPIODR4R**, **GPIODR8R**, **GPIODR12R**, **GPIOSLR**, and **GPIODR**.

Note: Port pins **PM[7:4]** operate as Fast GPIO pads but support only 2-, 4-, 6-, and 8-mA drive capability. 10- and 12-mA drive are not supported. All standard GPIO register controls, except for the **GPIODR12R** register, apply to these port pins.

10.3.5.1 Extended Drive Enable

The **GPIO Peripheral Configuration (GPIOPC)** register controls the extended drive modes of the GPIO. When the **EDE** bit in **GPIO Peripheral Properties (GPIOPP)** register is set and the **EDM_n** bit field for a GPIO pin is non-zero in the **GPIOPC** register, the **GPIODR_{nR}** registers do not drive their default value, but instead output an incremental drive strength, which has an additive effect. This allows for more drive strength possibilities. When the **EDE** bit is set and the **EDM_n** bit field is non-zero, the 2 mA driver is always enabled. Any bits enabled in the **GPIODR4R** register for a pin with a non-zero **EDM_n** value, add an additional 2 mA. Any bits set in the **GPIODR8R** add an extra 4 mA of drive. The **GPIODR12R** register is only valid when the **EDM_n** value is 0x3. For this encoding, setting a bit in the **GPIODR12R** register adds 4 mA of drive to the already existing 8 mA, for a 12 mA drive strength. To attain a 10-mA drive strength, the pin's **GPIODR12R** and **GPIODR8R** register should be enabled; this would result in the addition of two, 4-mA current drivers to the already enabled 2-mA driver. The table below shows the drive capability options. If **EDM_n** is 0x00, then the **GPIODR2R**, **GPIODR4R**, and **GPIODR8R** function as stated in their default register description.

Note: A **GPIOPC** register write must precede the configuration of the **GPIODR_{nR}** registers in order for extended drive mode to take effect.

Table 10-3. GPIO Drive Strength Options

EDE (GPIOPP)	EDMn (GPIOPC)	GPIO12R (+4mA)	GPIO8R (+4mA)	GPIO4R (+2mA)	GPIO2R (2mA)	Drive (mA)
X	0x0	N/A	0	0	1	2
			0	1	0	4
			1	0	0	8
1	0x1	N/A	0	0	N/A	2
			0	1	N/A	4
			1	0	N/A	6
			1	1	N/A	8
1	0x3	0	0	0	N/A	2
		0	0	1	N/A	4
		0	1	0	N/A	6
		0	1	1	N/A	8
		1	1	0	N/A	10
		1	1	1	N/A	12
		1	0	N/A	N/A	N/A
1	0x2	N/A	N/A	N/A	N/A	N/A

10.3.6 Identification

The identification registers configured at reset allow software to detect and identify the module as a GPIO block. The identification registers include the **GPIOPeriphID0-GPIOPeriphID7** registers as well as the **GPIOCellID0-GPIOCellID3** registers.

10.4 Initialization and Configuration

To configure the GPIO pins of a particular port, follow these steps:

1. Enable the clock to the port by setting the appropriate bits in the **RCGCGPIO** register (see page 389). In addition, the **SCGCGPIO** and **DCGCGPIO** registers can be programmed in the same manner to enable clocking in Sleep and Deep-Sleep modes.
2. Set the direction of the GPIO port pins by programming the **GPIODIR** register. A write of a 1 indicates output and a write of a 0 indicates input.
3. Configure the **GPIOAFSEL** register to program each bit as a GPIO or alternate pin. If an alternate pin is chosen for a bit, then the **PMCx** field must be programmed in the **GPIOCTL** register for the specific peripheral required. There are also two registers, **GPIOADCCTL** and **GPIODMACTL**, which can be used to program a GPIO pin as a ADC or μ DMA trigger, respectively.
4. Set the **EDMn** field in the **GPIOPC** register as shown in Table 10-3 on page 761.
5. Set or clear the **GPIO4R** register bits as shown in Table 10-3 on page 761.
6. Set or clear the **GPIO8R** register bits as shown in Table 10-3 on page 761.
7. Set or clear the **GPIO12R** register bits as shown in Table 10-3 on page 761.

8. Program each pad in the port to have either pull-up, pull-down, or open drain functionality through the **GPIOPUR**, **GPIOPDR**, **GPIOODR** register. Slew rate may also be programmed, if needed, through the **GPIOSLR** register.
9. To enable GPIO pins as digital I/Os, set the appropriate **DEN** bit in the **GPIODEN** register. To enable GPIO pins to their analog function (if available), set the **GPIOAMSEL** bit in the **GPIOAMSEL** register.
10. Program the **GPIOIS**, **GPIOIBE**, **GPIOEVS**, and **GPIOIM** registers to configure the type, event, and mask of the interrupts for each port.

Note: To prevent false interrupts, the following steps should be taken when re-configuring GPIO edge and interrupt sense registers:

 - a. Mask the corresponding port by clearing the **IME** field in the **GPIOIM** register.
 - b. Configure the **IS** field in the **GPIOIS** register and the **IBE** field in the **GPIOIBE** register.
 - c. Clear the **GPIORIS** register.
 - d. Unmask the port by setting the **IME** field in the **GPIOIM** register.
11. Optionally, software can lock the configurations of the NMI and JTAG/SWD pins on the GPIO port pins, by setting the **LOCK** bits in the **GPIOLOCK** register.

When the internal POR signal is asserted and until otherwise configured, all GPIO pins are configured to be undriven (tristate): **GPIOAFSEL=0**, **GPIODEN=0**, **GPIOPDR=0**, and **GPIOPUR=0** Table 10-4 on page 762 shows all possible configurations of the GPIO pads and the control register settings required to achieve them. Table 10-5 on page 763 shows how a rising edge interrupt is configured for pin 2 of a GPIO port.

Table 10-4. GPIO Pad Configuration Examples

Configuration	GPIO Register Bit Value ^a										
	AFSEL	DIR	ODR	DEN	PUR	PDR	DR2R	DR4R	DR8R	DR12R	SLR
Digital Input (GPIO)	0	0	0	1	?	?	X	X	X	X	X
Digital Output (GPIO)	0	1	0	1	?	?	?	?	?	?	?
Open Drain Output (GPIO)	0	1	1	1	X	X	?	?	?	?	?
Open Drain Input/Output (I2CSDA)	1	X	1	1	X	X	?	?	?	?	?
Digital Input/Output (I2CSCL)	1	X	0	1	X	X	?	?	?	?	?
Digital Input (Timer CCP)	1	X	0	1	?	?	X	X	X	X	X
Digital Input (QEI)	1	X	0	1	?	?	X	X	X	X	X
Digital Output (PWM)	1	X	0	1	?	?	?	?	?	?	?
Digital Output (Timer PWM)	1	X	0	1	?	?	?	?	?	?	?

Table 10-4. GPIO Pad Configuration Examples (continued)

Configuration	GPIO Register Bit Value ^a										
	AFSEL	DIR	ODR	DEN	PUR	PDR	DR2R	DR4R	DR8R	DR12R	SLR
Digital Input/Output (SSI)	1	X	0	1	?	?	?	?	?	?	?
Digital Input/Output (UART)	1	X	0	1	?	?	?	?	?	?	?
Analog Input (Comparator)	0	0	0	0	0	0	X	X	X	X	X
Digital Output (Comparator)	1	X	0	1	?	?	?	?	?	?	?

a. X=Ignored (don't care bit)

?=Can be either 0 or 1, depending on the configuration

Table 10-5. GPIO Interrupt Configuration Example

Register	Desired Interrupt Event Trigger	Pin 2 Bit Value ^a							
		7	6	5	4	3	2	1	0
GPIOIS	0=edge 1=level	X	X	X	X	X	0	X	X
GPIOIBE	0=single edge 1=both edges	X	X	X	X	X	0	X	X
GPIOIEV	0=Low level, or falling edge 1=High level, or rising edge	X	X	X	X	X	1	X	X
GPIOIM	0=masked 1=not masked	0	0	0	0	0	1	0	0

a. X=Ignored (don't care bit)

10.5 Register Map

Table 10-7 on page 765 lists the GPIO registers.

Important: The GPIO registers in this chapter are duplicated in each GPIO block; however, depending on the block, all eight bits may not be connected to a GPIO pad. In those cases, writing to unconnected bits has no effect, and reading unconnected bits returns no meaningful data. See “Signal Description” on page 751 for the GPIOs included on this device.

The offset listed is a hexadecimal increment to the register's address, relative to that GPIO port's base address:

- GPIO Port A (AHB): 0x4005.8000
- GPIO Port B (AHB): 0x4005.9000
- GPIO Port C (AHB): 0x4005.A000
- GPIO Port D (AHB): 0x4005.B000
- GPIO Port E (AHB): 0x4005.C000
- GPIO Port F (AHB): 0x4005.D000
- GPIO Port G (AHB): 0x4005.E000
- GPIO Port H (AHB): 0x4005.F000

- GPIO Port J (AHB): 0x4006.0000
- GPIO Port K (AHB): 0x4006.1000
- GPIO Port L (AHB): 0x4006.2000
- GPIO Port M (AHB): 0x4006.3000
- GPIO Port N (AHB): 0x4006.4000
- GPIO Port P (AHB): 0x4006.5000
- GPIO Port Q (AHB): 0x4006.6000

Note that each GPIO module clock must be enabled before the registers can be programmed (see page 389). There must be a delay of 3 system clocks after the GPIO module clock is enabled before any GPIO module registers are accessed.

Important: The table below shows special consideration GPIO pins. Most GPIO pins are configured as GPIOs and tri-stated by default (**GPIOAFSEL**=0, **GIODEN**=0, **GPIOPDR**=0, **GPIOPUR**=0, and **GPIOPCTL**=0). Special consideration pins may be programmed to a non-GPIO function or may have special commit controls out of reset. In addition, a Power-On-Reset (\overline{POR}) returns these GPIO to their original special consideration state.

Table 10-6. GPIO Pins With Special Considerations

GPIO Pins	Default Reset State	GPIOAFSEL	GIODEN	GPIOPDR	GPIOPUR	GPIOPCTL	GPIOCR
PC[3:0]	JTAG/SWD	1	1	0	1	0x1	0
PD[7]	GPIO ^a	0	0	0	0	0x0	0
PE[7]	GPIO ^a	0	0	0	0	0x0	0

a. This pin is configured as a GPIO by default but is locked and can only be reprogrammed by unlocking the pin in the **GPIOLOCK** register and uncommitting it by setting the **GPIOCR** register.

The GPIO commit control registers provide a layer of protection against accidental programming of critical hardware signals including the GPIO pins that can function as JTAG/SWD signals and the **NMI** signal. The commit control process must be followed for these pins, even if they are programmed as alternate functions other than JTAG/SWD or **NMI**; see “Commit Control” on page 760.

Note: If the device fails initialization during reset, the hardware toggles the **TDO** output as an indication of failure. Thus, during board layout, designers should not designate the **TDO** pin as a GPIO in sensitive applications where the possibility of toggling could affect the design.

The default register type for the **GPIOCR** register is RO for all GPIO pins with the exception of the **NMI** pin and the four JTAG/SWD pins (see “Signal Tables” on page 1896 for pin numbers). These six pins are the only GPIOs that are protected by the **GPIOCR** register. Because of this, the register type for the corresponding GPIO Ports is RW.

The default reset value for the **GPIOCR** register is 0x0000.00FF for all GPIO pins, with the exception of the **NMI** and JTAG/SWD pins (see “Signal Tables” on page 1896 for pin numbers). To ensure that the JTAG and **NMI** pins are not accidentally programmed as GPIO pins, these pins default to non-committable. Because of this, the default reset value of **GPIOCR** changes for the corresponding ports.

Table 10-7. GPIO Register Map

Offset	Name	Type	Reset	Description	See page
0x000	GPIODATA	RW	0x0000.0000	GPIO Data	767
0x400	GPIODIR	RW	0x0000.0000	GPIO Direction	768
0x404	GPIOIS	RW	0x0000.0000	GPIO Interrupt Sense	769
0x408	GPIOIBE	RW	0x0000.0000	GPIO Interrupt Both Edges	770
0x40C	GPIOIEV	RW	0x0000.0000	GPIO Interrupt Event	771
0x410	GPIOIM	RW	0x0000.0000	GPIO Interrupt Mask	772
0x414	GPIORIS	RO	0x0000.0000	GPIO Raw Interrupt Status	773
0x418	GIOMIS	RO	0x0000.0000	GPIO Masked Interrupt Status	775
0x41C	GPIOICR	W1C	0x0000.0000	GPIO Interrupt Clear	777
0x420	GPIOAFSEL	RW	-	GPIO Alternate Function Select	778
0x500	GPIODR2R	RW	0x0000.00FF	GPIO 2-mA Drive Select	780
0x504	GPIODR4R	RW	0x0000.0000	GPIO 4-mA Drive Select	781
0x508	GPIODR8R	RW	0x0000.0000	GPIO 8-mA Drive Select	782
0x50C	GPIOODR	RW	0x0000.0000	GPIO Open Drain Select	783
0x510	GIOPUR	RW	-	GPIO Pull-Up Select	784
0x514	GIOPDR	RW	0x0000.0000	GPIO Pull-Down Select	786
0x518	GPIOSLR	RW	0x0000.0000	GPIO Slew Rate Control Select	788
0x51C	GPIODEN	RW	-	GPIO Digital Enable	789
0x520	GPIOLOCK	RW	0x0000.0001	GPIO Lock	791
0x524	GPIOCR	-	-	GPIO Commit	792
0x528	GPIOAMSEL	RW	0x0000.0000	GPIO Analog Mode Select	794
0x52C	GIOPCTL	RW	-	GPIO Port Control	795
0x530	GPIOADCCTL	RW	0x0000.0000	GPIO ADC Control	797
0x534	GPIODMACTL	RW	0x0000.0000	GPIO DMA Control	798
0x538	GPIOSSI	RW	0x0000.0000	GPIO Select Interrupt	799
0x53C	GPIODR12R	RW	0x0000.0000	GPIO 12-mA Drive Select	800
0x540	GPIOWAKEPEN	RW	0x0000.0000	GPIO Wake Pin Enable	801
0x544	GPIOWAKELVL	RW	0x0000.0000	GPIO Wake Level	803
0x548	GPIOWAKESTAT	RO	0x0000.0000	GPIO Wake Status	805
0xFC0	GPIOPP	RO	0x0000.0001	GPIO Peripheral Property	807
0xFC4	GPIOPC	RW	0x0000.0000	GPIO Peripheral Configuration	808
0xFD0	GPIOPeriphID4	RO	0x0000.0000	GPIO Peripheral Identification 4	811

Table 10-7. GPIO Register Map (continued)

Offset	Name	Type	Reset	Description	See page
0xFD4	GPIOPeriphID5	RO	0x0000.0000	GPIO Peripheral Identification 5	812
0xFD8	GPIOPeriphID6	RO	0x0000.0000	GPIO Peripheral Identification 6	813
0xFDC	GPIOPeriphID7	RO	0x0000.0000	GPIO Peripheral Identification 7	814
0xFE0	GPIOPeriphID0	RO	0x0000.0061	GPIO Peripheral Identification 0	815
0xFE4	GPIOPeriphID1	RO	0x0000.0000	GPIO Peripheral Identification 1	816
0xFE8	GPIOPeriphID2	RO	0x0000.0018	GPIO Peripheral Identification 2	817
0xFEC	GPIOPeriphID3	RO	0x0000.0001	GPIO Peripheral Identification 3	818
0xFF0	GPIOPrimeCellID0	RO	0x0000.000D	GPIO PrimeCell Identification 0	819
0xFF4	GPIOPrimeCellID1	RO	0x0000.00F0	GPIO PrimeCell Identification 1	820
0xFF8	GPIOPrimeCellID2	RO	0x0000.0005	GPIO PrimeCell Identification 2	821
0xFFC	GPIOPrimeCellID3	RO	0x0000.00B1	GPIO PrimeCell Identification 3	822

10.6 Register Descriptions

The remainder of this section lists and describes the GPIO registers, in numerical order by address offset.

Register 1: GPIO Data (GPIODATA), offset 0x000

The **GPIODATA** register is the data register. In software control mode, values written in the **GPIODATA** register are transferred onto the GPIO port pins if the respective pins have been configured as outputs through the **GPIO Direction (GPIODIR)** register (see page 768).

In order to write to **GPIODATA**, the corresponding bits in the mask, resulting from the address bus bits [9:2], must be set. Otherwise, the bit values remain unchanged by the write.

Similarly, the values read from this register are determined for each bit by the mask bit derived from the address used to access the data register, bits [9:2]. Bits that are set in the address mask cause the corresponding bits in **GPIODATA** to be read, and bits that are clear in the address mask cause the corresponding bits in **GPIODATA** to be read as 0, regardless of their value.

A read from **GPIODATA** returns the last bit value written if the respective pins are configured as outputs, or it returns the value on the corresponding input pin when these are configured as inputs. All bits are cleared by a reset.

GPIO Data (GPIODATA)

GPIO Port A (AHB) base: 0x4005.8000
 GPIO Port B (AHB) base: 0x4005.9000
 GPIO Port C (AHB) base: 0x4005.A000
 GPIO Port D (AHB) base: 0x4005.B000
 GPIO Port E (AHB) base: 0x4005.C000
 GPIO Port F (AHB) base: 0x4005.D000
 GPIO Port G (AHB) base: 0x4005.E000
 GPIO Port H (AHB) base: 0x4005.F000
 GPIO Port J (AHB) base: 0x4006.0000
 GPIO Port K (AHB) base: 0x4006.1000
 GPIO Port L (AHB) base: 0x4006.2000
 GPIO Port M (AHB) base: 0x4006.3000
 GPIO Port N (AHB) base: 0x4006.4000
 GPIO Port P (AHB) base: 0x4006.5000
 GPIO Port Q (AHB) base: 0x4006.6000
 Offset 0x000
 Type RW, reset 0x0000.0000

	31	30	29	28	27	26	25	24	23	22	21	20	19	18	17	16
	reserved															
Type	RO	RO	RO	RO	RO	RO	RO	RO	RO	RO	RO	RO	RO	RO	RO	RO
Reset	0	0	0	0	0	0	0	0	0	0	0	0	0	0	0	0
	15	14	13	12	11	10	9	8	7	6	5	4	3	2	1	0
	reserved								DATA							
Type	RO	RO	RO	RO	RO	RO	RO	RO	RW	RW	RW	RW	RW	RW	RW	RW
Reset	0	0	0	0	0	0	0	0	0	0	0	0	0	0	0	0

Bit/Field	Name	Type	Reset	Description
31:8	reserved	RO	0x0000.00	Software should not rely on the value of a reserved bit. To provide compatibility with future products, the value of a reserved bit should be preserved across a read-modify-write operation.
7:0	DATA	RW	0x00	GPIO Data This register is virtually mapped to 256 locations in the address space. To facilitate the reading and writing of data to these registers by independent drivers, the data read from and written to the registers are masked by the eight address lines [9:2]. Reads from this register return its current state. Writes to this register only affect bits that are not masked by ADDR[9:2] and are configured as outputs. See "Data Register Operation" on page 757 for examples of reads and writes.

Register 2: GPIO Direction (GPIODIR), offset 0x400

The **GPIODIR** register is the data direction register. Setting a bit in the **GPIODIR** register configures the corresponding pin to be an output, while clearing a bit configures the corresponding pin to be an input. All bits are cleared by a reset, meaning all GPIO pins are inputs by default.

GPIO Direction (GPIODIR)

GPIO Port A (AHB) base: 0x4005.8000
 GPIO Port B (AHB) base: 0x4005.9000
 GPIO Port C (AHB) base: 0x4005.A000
 GPIO Port D (AHB) base: 0x4005.B000
 GPIO Port E (AHB) base: 0x4005.C000
 GPIO Port F (AHB) base: 0x4005.D000
 GPIO Port G (AHB) base: 0x4005.E000
 GPIO Port H (AHB) base: 0x4005.F000
 GPIO Port J (AHB) base: 0x4006.0000
 GPIO Port K (AHB) base: 0x4006.1000
 GPIO Port L (AHB) base: 0x4006.2000
 GPIO Port M (AHB) base: 0x4006.3000
 GPIO Port N (AHB) base: 0x4006.4000
 GPIO Port P (AHB) base: 0x4006.5000
 GPIO Port Q (AHB) base: 0x4006.6000
 Offset 0x400

Type RW, reset 0x0000.0000

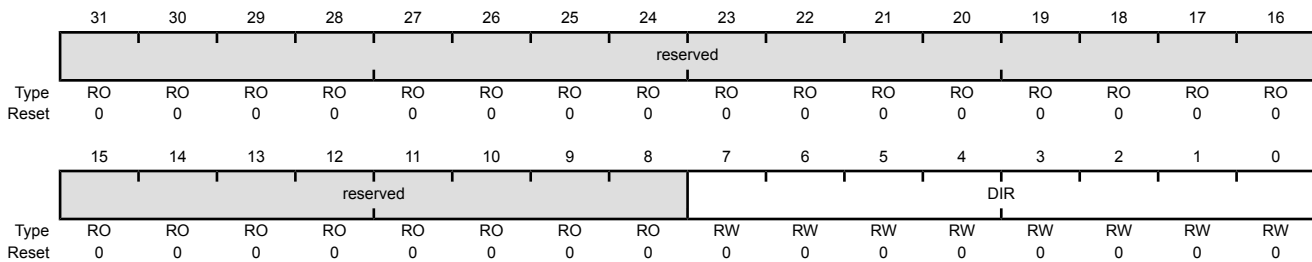

Bit/Field	Name	Type	Reset	Description
31:8	reserved	RO	0x0000.00	Software should not rely on the value of a reserved bit. To provide compatibility with future products, the value of a reserved bit should be preserved across a read-modify-write operation.
7:0	DIR	RW	0x00	GPIO Data Direction
				Value Description
				0 Corresponding pin is an input.
				1 Corresponding pins is an output.

Register 3: GPIO Interrupt Sense (GPIOIS), offset 0x404

The **GPIOIS** register is the interrupt sense register. Setting a bit in the **GPIOIS** register configures the corresponding pin to detect levels, while clearing a bit configures the corresponding pin to detect edges. All bits are cleared by a reset.

Note: To prevent false interrupts, the following steps should be taken when re-configuring GPIO edge and interrupt sense registers:

1. Mask the corresponding port by clearing the **IME** field in the **GPIOIM** register.
2. Configure the **IS** field in the **GPIOIS** register and the **IBE** field in the **GPIOIBE** register.
3. Clear the **GPORIS** register.
4. Unmask the port by setting the **IME** field in the **GPIOIM** register.

GPIO Interrupt Sense (GPIOIS)

GPIO Port A (AHB) base: 0x4005.8000
 GPIO Port B (AHB) base: 0x4005.9000
 GPIO Port C (AHB) base: 0x4005.A000
 GPIO Port D (AHB) base: 0x4005.B000
 GPIO Port E (AHB) base: 0x4005.C000
 GPIO Port F (AHB) base: 0x4005.D000
 GPIO Port G (AHB) base: 0x4005.E000
 GPIO Port H (AHB) base: 0x4005.F000
 GPIO Port J (AHB) base: 0x4006.0000
 GPIO Port K (AHB) base: 0x4006.1000
 GPIO Port L (AHB) base: 0x4006.2000
 GPIO Port M (AHB) base: 0x4006.3000
 GPIO Port N (AHB) base: 0x4006.4000
 GPIO Port P (AHB) base: 0x4006.5000
 GPIO Port Q (AHB) base: 0x4006.6000
 Offset 0x404

Type RW, reset 0x0000.0000

	31	30	29	28	27	26	25	24	23	22	21	20	19	18	17	16
	reserved															
Type	RO	RO	RO	RO	RO	RO	RO	RO	RO	RO	RO	RO	RO	RO	RO	RO
Reset	0	0	0	0	0	0	0	0	0	0	0	0	0	0	0	0
	15	14	13	12	11	10	9	8	7	6	5	4	3	2	1	0
	reserved								IS							
Type	RO	RO	RO	RO	RO	RO	RO	RO	RW	RW	RW	RW	RW	RW	RW	RW
Reset	0	0	0	0	0	0	0	0	0	0	0	0	0	0	0	0

Bit/Field	Name	Type	Reset	Description
31:8	reserved	RO	0x0000.00	Software should not rely on the value of a reserved bit. To provide compatibility with future products, the value of a reserved bit should be preserved across a read-modify-write operation.
7:0	IS	RW	0x00	GPIO Interrupt Sense
				Value Description
				0 The edge on the corresponding pin is detected (edge-sensitive).
				1 The level on the corresponding pin is detected (level-sensitive).

Register 4: GPIO Interrupt Both Edges (GPIOIBE), offset 0x408

The **GPIOIBE** register allows both edges to cause interrupts. When the corresponding bit in the **GPIO Interrupt Sense (GPIOIS)** register (see page 769) is set to detect edges, setting a bit in the **GPIOIBE** register configures the corresponding pin to detect both rising and falling edges, regardless of the corresponding bit in the **GPIO Interrupt Event (GPIOIEV)** register (see page 771). Clearing a bit configures the pin to be controlled by the **GPIOIEV** register. All bits are cleared by a reset.

Note: To prevent false interrupts, the following steps should be taken when re-configuring GPIO edge and interrupt sense registers:

1. Mask the corresponding port by clearing the **IME** field in the **GPIOIM** register.
2. Configure the **IS** field in the **GPIOIS** register and the **IBE** field in the **GPIOIBE** register.
3. Clear the **GPIORIS** register.
4. Unmask the port by setting the **IME** field in the **GPIOIM** register.

GPIO Interrupt Both Edges (GPIOIBE)

GPIO Port A (AHB) base: 0x4005.8000
 GPIO Port B (AHB) base: 0x4005.9000
 GPIO Port C (AHB) base: 0x4005.A000
 GPIO Port D (AHB) base: 0x4005.B000
 GPIO Port E (AHB) base: 0x4005.C000
 GPIO Port F (AHB) base: 0x4005.D000
 GPIO Port G (AHB) base: 0x4005.E000
 GPIO Port H (AHB) base: 0x4005.F000
 GPIO Port J (AHB) base: 0x4006.0000
 GPIO Port K (AHB) base: 0x4006.1000
 GPIO Port L (AHB) base: 0x4006.2000
 GPIO Port M (AHB) base: 0x4006.3000
 GPIO Port N (AHB) base: 0x4006.4000
 GPIO Port P (AHB) base: 0x4006.5000
 GPIO Port Q (AHB) base: 0x4006.6000
 Offset 0x408
 Type RW, reset 0x0000.0000

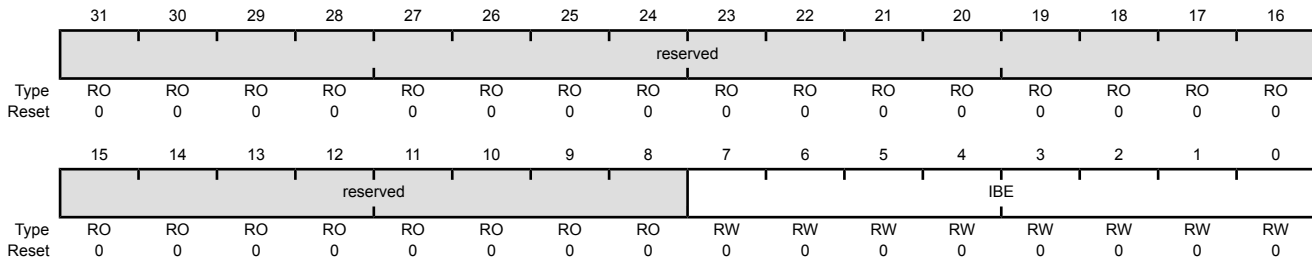

Bit/Field	Name	Type	Reset	Description
31:8	reserved	RO	0x0000.00	Software should not rely on the value of a reserved bit. To provide compatibility with future products, the value of a reserved bit should be preserved across a read-modify-write operation.
7:0	IBE	RW	0x00	GPIO Interrupt Both Edges
				Value Description
				0 Interrupt generation is controlled by the GPIO Interrupt Event (GPIOIEV) register (see page 771).
				1 Both edges on the corresponding pin trigger an interrupt.

Register 5: GPIO Interrupt Event (GPIOIEV), offset 0x40C

The **GPIOIEV** register is the interrupt event register. Setting a bit in the **GPIOIEV** register configures the corresponding pin to detect rising edges or high levels, depending on the corresponding bit value in the **GPIO Interrupt Sense (GPIOIS)** register (see page 769). Clearing a bit configures the pin to detect falling edges or low levels, depending on the corresponding bit value in the **GPIOIS** register. All bits are cleared by a reset.

GPIO Interrupt Event (GPIOIEV)

GPIO Port A (AHB) base: 0x4005.8000
 GPIO Port B (AHB) base: 0x4005.9000
 GPIO Port C (AHB) base: 0x4005.A000
 GPIO Port D (AHB) base: 0x4005.B000
 GPIO Port E (AHB) base: 0x4005.C000
 GPIO Port F (AHB) base: 0x4005.D000
 GPIO Port G (AHB) base: 0x4005.E000
 GPIO Port H (AHB) base: 0x4005.F000
 GPIO Port J (AHB) base: 0x4006.0000
 GPIO Port K (AHB) base: 0x4006.1000
 GPIO Port L (AHB) base: 0x4006.2000
 GPIO Port M (AHB) base: 0x4006.3000
 GPIO Port N (AHB) base: 0x4006.4000
 GPIO Port P (AHB) base: 0x4006.5000
 GPIO Port Q (AHB) base: 0x4006.6000
 Offset 0x40C

Type RW, reset 0x0000.0000

	31	30	29	28	27	26	25	24	23	22	21	20	19	18	17	16
	reserved															
Type	RO	RO	RO	RO	RO	RO	RO	RO	RO	RO	RO	RO	RO	RO	RO	RO
Reset	0	0	0	0	0	0	0	0	0	0	0	0	0	0	0	0
	15	14	13	12	11	10	9	8	7	6	5	4	3	2	1	0
	reserved								IEV							
Type	RO	RO	RO	RO	RO	RO	RO	RO	RW	RW	RW	RW	RW	RW	RW	RW
Reset	0	0	0	0	0	0	0	0	0	0	0	0	0	0	0	0

Bit/Field	Name	Type	Reset	Description
31:8	reserved	RO	0x0000.00	Software should not rely on the value of a reserved bit. To provide compatibility with future products, the value of a reserved bit should be preserved across a read-modify-write operation.
7:0	IEV	RW	0x00	GPIO Interrupt Event
				Value Description
			0	A falling edge or a Low level on the corresponding pin triggers an interrupt.
			1	A rising edge or a High level on the corresponding pin triggers an interrupt.

Register 6: GPIO Interrupt Mask (GPIOIM), offset 0x410

The **GPIOIM** register is the interrupt mask register. Setting a bit in the **GPIOIM** register allows interrupts that are generated by the corresponding pin to be sent to the interrupt controller on the combined interrupt signal. Clearing a bit prevents an interrupt on the corresponding pin from being sent to the interrupt controller. All bits are cleared by a reset.

GPIO Interrupt Mask (GPIOIM)

GPIO Port A (AHB) base: 0x4005.8000
 GPIO Port B (AHB) base: 0x4005.9000
 GPIO Port C (AHB) base: 0x4005.A000
 GPIO Port D (AHB) base: 0x4005.B000
 GPIO Port E (AHB) base: 0x4005.C000
 GPIO Port F (AHB) base: 0x4005.D000
 GPIO Port G (AHB) base: 0x4005.E000
 GPIO Port H (AHB) base: 0x4005.F000
 GPIO Port J (AHB) base: 0x4006.0000
 GPIO Port K (AHB) base: 0x4006.1000
 GPIO Port L (AHB) base: 0x4006.2000
 GPIO Port M (AHB) base: 0x4006.3000
 GPIO Port N (AHB) base: 0x4006.4000
 GPIO Port P (AHB) base: 0x4006.5000
 GPIO Port Q (AHB) base: 0x4006.6000
 Offset 0x410

Type RW, reset 0x0000.0000

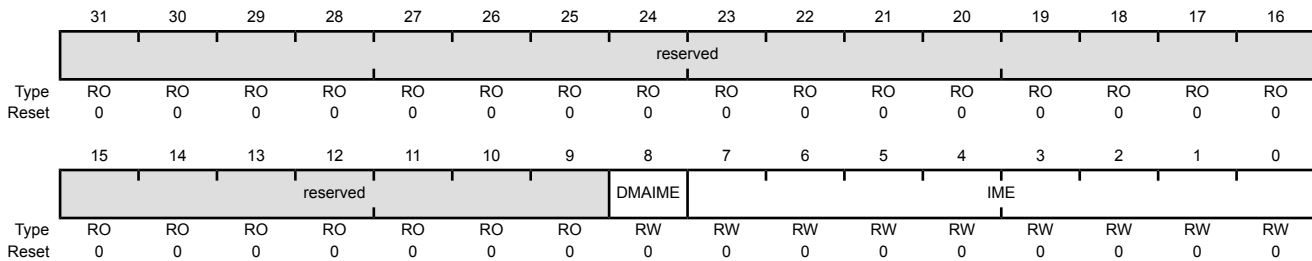

Bit/Field	Name	Type	Reset	Description
31:9	reserved	RO	0	Software should not rely on the value of a reserved bit. To provide compatibility with future products, the value of a reserved bit should be preserved across a read-modify-write operation.
8	DMAIME	RW	0	GPIO uDMA Done Interrupt Mask Enable Value Description 0 The μ DMA done interrupt is masked and does not cause an interrupt. 1 The μ DMA done interrupt is not masked and can generate an interrupt to the interrupt controller.
7:0	IME	RW	0x00	GPIO Interrupt Mask Enable Value Description 0 The interrupt from the corresponding pin is masked. 1 The interrupt from the corresponding pin is sent to the interrupt controller.

Register 7: GPIO Raw Interrupt Status (GPIORIS), offset 0x414

The **GPIORIS** register is the raw interrupt status register. A bit in this register is set when an interrupt condition occurs on the corresponding GPIO pin or if a μ DMA done interrupt occurs. If the corresponding bit in the **GPIO Interrupt Mask (GPIOIM)** register (see page 772) is set, the interrupt is sent to the interrupt controller. Bits read as zero indicate that corresponding input pins have not initiated an interrupt. For a GPIO level-detect interrupt, the interrupt signal generating the interrupt must be held until serviced. Once the input signal deasserts from the interrupt generating logical sense, the corresponding **RIS** bit in the **GPIORIS** register clears. For a GPIO edge-detect interrupt, the **RIS** bit in the **GPIORIS** register is cleared by writing a '1' to the corresponding bit in the **GPIO Interrupt Clear (GPIOICR)** register. The corresponding **GPIOMIS** bit reflects the masked value of the **RIS** bit.

GPIO Raw Interrupt Status (GPIORIS)

GPIO Port A (AHB) base: 0x4005.8000
 GPIO Port B (AHB) base: 0x4005.9000
 GPIO Port C (AHB) base: 0x4005.A000
 GPIO Port D (AHB) base: 0x4005.B000
 GPIO Port E (AHB) base: 0x4005.C000
 GPIO Port F (AHB) base: 0x4005.D000
 GPIO Port G (AHB) base: 0x4005.E000
 GPIO Port H (AHB) base: 0x4005.F000
 GPIO Port J (AHB) base: 0x4006.0000
 GPIO Port K (AHB) base: 0x4006.1000
 GPIO Port L (AHB) base: 0x4006.2000
 GPIO Port M (AHB) base: 0x4006.3000
 GPIO Port N (AHB) base: 0x4006.4000
 GPIO Port P (AHB) base: 0x4006.5000
 GPIO Port Q (AHB) base: 0x4006.6000
 Offset 0x414
 Type RO, reset 0x0000.0000

	31	30	29	28	27	26	25	24	23	22	21	20	19	18	17	16
	reserved															
Type	RO	RO	RO	RO	RO	RO	RO	RO	RO	RO	RO	RO	RO	RO	RO	RO
Reset	0	0	0	0	0	0	0	0	0	0	0	0	0	0	0	0
	15	14	13	12	11	10	9	8	7	6	5	4	3	2	1	0
	reserved							DMARIS	RIS							
Type	RO	RO	RO	RO	RO	RO	RO	RO	RO	RO	RO	RO	RO	RO	RO	RO
Reset	0	0	0	0	0	0	0	0	0	0	0	0	0	0	0	0

Bit/Field	Name	Type	Reset	Description
31:9	reserved	RO	0	Software should not rely on the value of a reserved bit. To provide compatibility with future products, the value of a reserved bit should be preserved across a read-modify-write operation.
8	DMARIS	RO	0	GPIO μ DMA Done Interrupt Raw Status
				Value Description
				0 A μ DMA done interrupt has not occurred.
				1 A μ DMA done interrupt has occurred and an interrupt has been triggered and is pending.

This bit is cleared by writing a 1 to the **DMARIS** bit in the **GPIOICR** register.

Bit/Field	Name	Type	Reset	Description
7:0	RIS	RO	0x00	GPIO Interrupt Raw Status
				Value Description
				0 An interrupt condition has not occurred on the corresponding pin.
				1 An interrupt condition has occurred on the corresponding pin.
				For edge-detect interrupts, this bit is cleared by writing a 1 to the corresponding bit in the GPIOICR register.
				For a GPIO level-detect interrupt, the bit is cleared when the level is deasserted.

Register 8: GPIO Masked Interrupt Status (GPIOMIS), offset 0x418

The **GPIOMIS** register is the masked interrupt status register. If a bit is set in this register, the corresponding interrupt has triggered an interrupt to the interrupt controller. If a bit is clear, either no interrupt has been generated, or the interrupt is masked.

Note that if the Port B **GPIOADCTL** register is cleared, PB4 can still be used as an external trigger for the ADC. This is a legacy mode which allows code written for previous devices to operate on this microcontroller.

GPIOMIS is the state of the interrupt after masking.

GPIO Masked Interrupt Status (GPIOMIS)

GPIO Port A (AHB) base: 0x4005.8000
 GPIO Port B (AHB) base: 0x4005.9000
 GPIO Port C (AHB) base: 0x4005.A000
 GPIO Port D (AHB) base: 0x4005.B000
 GPIO Port E (AHB) base: 0x4005.C000
 GPIO Port F (AHB) base: 0x4005.D000
 GPIO Port G (AHB) base: 0x4005.E000
 GPIO Port H (AHB) base: 0x4005.F000
 GPIO Port J (AHB) base: 0x4006.0000
 GPIO Port K (AHB) base: 0x4006.1000
 GPIO Port L (AHB) base: 0x4006.2000
 GPIO Port M (AHB) base: 0x4006.3000
 GPIO Port N (AHB) base: 0x4006.4000
 GPIO Port P (AHB) base: 0x4006.5000
 GPIO Port Q (AHB) base: 0x4006.6000
 Offset 0x418

Type RO, reset 0x0000.0000

	31	30	29	28	27	26	25	24	23	22	21	20	19	18	17	16
	reserved															
Type	RO	RO	RO	RO	RO	RO	RO	RO	RO	RO	RO	RO	RO	RO	RO	RO
Reset	0	0	0	0	0	0	0	0	0	0	0	0	0	0	0	0
	15	14	13	12	11	10	9	8	7	6	5	4	3	2	1	0
	reserved							DMAMIS	MIS							
Type	RO	RO	RO	RO	RO	RO	RO	RO	RO	RO	RO	RO	RO	RO	RO	RO
Reset	0	0	0	0	0	0	0	0	0	0	0	0	0	0	0	0

Bit/Field	Name	Type	Reset	Description
31:9	reserved	RO	0	Software should not rely on the value of a reserved bit. To provide compatibility with future products, the value of a reserved bit should be preserved across a read-modify-write operation.
8	DMAMIS	RO	0	GPIO μ DMA Done Masked Interrupt Status
				Value Description
				0 The μ DMA done interrupt is masked or has not occurred.
				1 An unmasked μ DMA done interrupt has occurred.

This bit is cleared by writing a 1 to the **DMAIC** bit in the **GPIOICR** register.

Bit/Field	Name	Type	Reset	Description
7:0	MIS	RO	0x00	GPIO Masked Interrupt Status Value Description 0 An interrupt condition on the corresponding pin is masked or has not occurred. 1 An interrupt condition on the corresponding pin has triggered an interrupt to the interrupt controller. For edge-detect interrupts, this bit is cleared by writing a 1 to the corresponding bit in the GPIOICR register. For a GPIO level-detect interrupt, the bit is cleared when the level is deasserted.

Register 9: GPIO Interrupt Clear (GPIOICR), offset 0x41C

The **GPIOICR** register is the interrupt clear register. Writing a 1 to the **DMAIC** bit in this register clears the corresponding interrupt bit in the **GPIORIS** and **GPIOMIS** registers. For edge-detect interrupts, writing a 1 to the **IC** bit in the **GPIOICR** register clears the corresponding bit in the **GPIORIS** and **GPIOMIS** registers. If the interrupt is a level-detect, the **IC** bit in this register has no effect. In addition, writing a 0 to any of the bits in the **GPIOICR** register has no effect.

GPIO Interrupt Clear (GPIOICR)

GPIO Port A (AHB) base: 0x4005.8000
 GPIO Port B (AHB) base: 0x4005.9000
 GPIO Port C (AHB) base: 0x4005.A000
 GPIO Port D (AHB) base: 0x4005.B000
 GPIO Port E (AHB) base: 0x4005.C000
 GPIO Port F (AHB) base: 0x4005.D000
 GPIO Port G (AHB) base: 0x4005.E000
 GPIO Port H (AHB) base: 0x4005.F000
 GPIO Port J (AHB) base: 0x4006.0000
 GPIO Port K (AHB) base: 0x4006.1000
 GPIO Port L (AHB) base: 0x4006.2000
 GPIO Port M (AHB) base: 0x4006.3000
 GPIO Port N (AHB) base: 0x4006.4000
 GPIO Port P (AHB) base: 0x4006.5000
 GPIO Port Q (AHB) base: 0x4006.6000
 Offset 0x41C
 Type W1C, reset 0x0000.0000

	31	30	29	28	27	26	25	24	23	22	21	20	19	18	17	16
	reserved															
Type	RO	RO	RO	RO	RO	RO	RO	RO	RO	RO	RO	RO	RO	RO	RO	RO
Reset	0	0	0	0	0	0	0	0	0	0	0	0	0	0	0	0
	15	14	13	12	11	10	9	8	7	6	5	4	3	2	1	0
	reserved							DMAIC	IC							
Type	RO	RO	RO	RO	RO	RO	RO	W1C	W1C	W1C	W1C	W1C	W1C	W1C	W1C	W1C
Reset	0	0	0	0	0	0	0	0	0	0	0	0	0	0	0	0

Bit/Field	Name	Type	Reset	Description
31:9	reserved	RO	0	Software should not rely on the value of a reserved bit. To provide compatibility with future products, the value of a reserved bit should be preserved across a read-modify-write operation.
8	DMAIC	W1C	0	GPIO μ DMA Interrupt Clear Value Description 0 The μ DMA done interrupt is unaffected. 1 The μ DMA done interrupt is cleared.
7:0	IC	W1C	0x00	GPIO Interrupt Clear Value Description 0 The corresponding interrupt is unaffected. 1 The corresponding interrupt is cleared.

Register 10: GPIO Alternate Function Select (GPIOAFSEL), offset 0x420

Note: Tamper pins enabled in the **Hibernate Tamper IO Control and Status (HIBTPIO)** register override the AFSEL configuration.

The **GPIOAFSEL** register is the mode control select register. If a bit is clear, the pin is used as a GPIO and is controlled by the GPIO registers. Setting a bit in this register configures the corresponding GPIO line to be controlled by an associated peripheral. Several possible peripheral functions are multiplexed on each GPIO. The **GPIO Port Control (GPIOPCTL)** register is used to select one of the possible functions. Table 29-5 on page 1932 details which functions are muxed on each GPIO pin. The reset value for this register is 0x0000.0000 for GPIO ports that are not listed in the table below.

Important: The table below shows special consideration GPIO pins. Most GPIO pins are configured as GPIOs and tri-stated by default (**GPIOAFSEL=0**, **GPIODEN=0**, **GPIOPDR=0**, **GPIOPUR=0**, and **GPIOPCTL=0**). Special consideration pins may be programmed to a non-GPIO function or may have special commit controls out of reset. In addition, a Power-On-Reset (\overline{POR}) returns these GPIO to their original special consideration state.

Table 10-8. GPIO Pins With Special Considerations

GPIO Pins	Default Reset State	GPIOAFSEL	GPIODEN	GPIOPDR	GPIOPUR	GPIOPCTL	GPIOCR
PC[3:0]	JTAG/SWD	1	1	0	1	0x1	0
PD[7]	GPIO ^a	0	0	0	0	0x0	0
PE[7]	GPIO ^a	0	0	0	0	0x0	0

a. This pin is configured as a GPIO by default but is locked and can only be reprogrammed by unlocking the pin in the **GPIOLOCK** register and uncommitting it by setting the **GPIOCR** register.

The GPIO commit control registers provide a layer of protection against accidental programming of critical hardware signals including the GPIO pins that can function as JTAG/SWD signals and the **NMI** signal. The commit control process must be followed for these pins, even if they are programmed as alternate functions other than JTAG/SWD or NMI; see “Commit Control” on page 760.

Note: If the device fails initialization during reset, the hardware toggles the **TDO** output as an indication of failure. Thus, during board layout, designers should not designate the **TDO** pin as a GPIO in sensitive applications where the possibility of toggling could affect the design.

Caution – It is possible to create a software sequence that prevents the debugger from connecting to the TM4C129ENC PDT microcontroller. If the program code loaded into flash immediately changes the JTAG pins to their GPIO functionality, the debugger may not have enough time to connect and halt the controller before the JTAG pin functionality switches. As a result, the debugger may be locked out of the part. This issue can be avoided with a software routine that restores JTAG functionality based on an external or software trigger. In the case that the software routine is not implemented and the device is locked out of the part, this issue can be solved by using the TM4C129ENC PDT Flash Programmer "Unlock" feature. Please refer to [LMFLASHPROGRAMMER](#) on the TI web for more information.

The GPIO commit control registers provide a layer of protection against accidental programming of critical hardware peripherals. Protection is provided for the GPIO pins that can be used as the four JTAG/SWD pins and the **NMI** pin (see “Signal Tables” on page 1896 for pin numbers). Writes to protected bits of the **GPIO Alternate Function Select (GPIOAFSEL)** register (see page 778), **GPIO**

Pull Up Select (GPIOPUR) register (see page 784), **GPIO Pull-Down Select (GPIOPDR)** register (see page 786), and **GPIO Digital Enable (GPIODEN)** register (see page 789) are not committed to storage unless the **GPIO Lock (GPIOLOCK)** register (see page 791) has been unlocked and the appropriate bits of the **GPIO Commit (GPIOCR)** register (see page 792) have been set.

When using the I²C module, in addition to setting the **GPIOAFSEL** register bits for the I²C clock and data pins, the data pins should be set to open drain using the **GPIO Open Drain Select (GPIOODR)** register (see examples in “Initialization and Configuration” on page 761).

GPIO Alternate Function Select (GPIOAFSEL)

GPIO Port A (AHB) base: 0x4005.8000
 GPIO Port B (AHB) base: 0x4005.9000
 GPIO Port C (AHB) base: 0x4005.A000
 GPIO Port D (AHB) base: 0x4005.B000
 GPIO Port E (AHB) base: 0x4005.C000
 GPIO Port F (AHB) base: 0x4005.D000
 GPIO Port G (AHB) base: 0x4005.E000
 GPIO Port H (AHB) base: 0x4005.F000
 GPIO Port J (AHB) base: 0x4006.0000
 GPIO Port K (AHB) base: 0x4006.1000
 GPIO Port L (AHB) base: 0x4006.2000
 GPIO Port M (AHB) base: 0x4006.3000
 GPIO Port N (AHB) base: 0x4006.4000
 GPIO Port P (AHB) base: 0x4006.5000
 GPIO Port Q (AHB) base: 0x4006.6000
 Offset 0x420
 Type RW, reset -

	31	30	29	28	27	26	25	24	23	22	21	20	19	18	17	16
	reserved															
Type	RO	RO	RO	RO	RO	RO	RO	RO	RO	RO	RO	RO	RO	RO	RO	RO
Reset	0	0	0	0	0	0	0	0	0	0	0	0	0	0	0	0
	15	14	13	12	11	10	9	8	7	6	5	4	3	2	1	0
	reserved								AFSEL							
Type	RO	RO	RO	RO	RO	RO	RO	RO	RW	RW	RW	RW	RW	RW	RW	RW
Reset	0	0	0	0	0	0	0	0	-	-	-	-	-	-	-	-

Bit/Field	Name	Type	Reset	Description
31:8	reserved	RO	0x0000.00	Software should not rely on the value of a reserved bit. To provide compatibility with future products, the value of a reserved bit should be preserved across a read-modify-write operation.
7:0	AFSEL	RW	-	GPIO Alternate Function Select

Value Description

- | | |
|---|---|
| 0 | The associated pin functions as a GPIO and is controlled by the GPIO registers. |
| 1 | The associated pin functions as a peripheral signal and is controlled by the alternate hardware function. |
- The reset value for this register is 0x0000.0000 for GPIO ports that are not listed in Table 10-1 on page 751.

Register 11: GPIO 2-mA Drive Select (GPIODR2R), offset 0x500

The **GPIODR2R** register is the 2-mA drive control register. Each GPIO signal in the port can be individually configured without affecting the other pads. When setting the **DRV2** bit for a GPIO signal, the corresponding **DRV4** bit in the **GPIODR4R** register and **DRV8** bit in the **GPIODR8R** register are automatically cleared by hardware. By default, all GPIO pins have 2-mA drive.

Note: This register has no effect on port pins **PL6** and **PL7**.

GPIO 2-mA Drive Select (GPIODR2R)

GPIO Port A (AHB) base: 0x4005.8000
 GPIO Port B (AHB) base: 0x4005.9000
 GPIO Port C (AHB) base: 0x4005.A000
 GPIO Port D (AHB) base: 0x4005.B000
 GPIO Port E (AHB) base: 0x4005.C000
 GPIO Port F (AHB) base: 0x4005.D000
 GPIO Port G (AHB) base: 0x4005.E000
 GPIO Port H (AHB) base: 0x4005.F000
 GPIO Port J (AHB) base: 0x4006.0000
 GPIO Port K (AHB) base: 0x4006.1000
 GPIO Port L (AHB) base: 0x4006.2000
 GPIO Port M (AHB) base: 0x4006.3000
 GPIO Port N (AHB) base: 0x4006.4000
 GPIO Port P (AHB) base: 0x4006.5000
 GPIO Port Q (AHB) base: 0x4006.6000
 Offset 0x500
 Type RW, reset 0x0000.00FF

	31	30	29	28	27	26	25	24	23	22	21	20	19	18	17	16
	reserved															
Type	RO	RO	RO	RO	RO	RO	RO	RO	RO	RO	RO	RO	RO	RO	RO	RO
Reset	0	0	0	0	0	0	0	0	0	0	0	0	0	0	0	0
	15	14	13	12	11	10	9	8	7	6	5	4	3	2	1	0
	reserved								DRV2							
Type	RO	RO	RO	RO	RO	RO	RO	RO	RW	RW	RW	RW	RW	RW	RW	RW
Reset	0	0	0	0	0	0	0	0	1	1	1	1	1	1	1	1

Bit/Field	Name	Type	Reset	Description
31:8	reserved	RO	0x0000.00	Software should not rely on the value of a reserved bit. To provide compatibility with future products, the value of a reserved bit should be preserved across a read-modify-write operation.
7:0	DRV2	RW	0xFF	Output Pad 2-mA Drive Enable

Value	Description
0	The drive for the corresponding GPIO pin is controlled by the GPIODR4R or GPIODR8R register.
1	The corresponding GPIO pin has 2-mA drive.

Setting a bit in either the **GPIODR4** register or the **GPIODR8** register clears the corresponding 2-mA enable bit. The change is effective on the next clock cycle.

Register 12: GPIO 4-mA Drive Select (GPIODR4R), offset 0x504

The **GPIODR4R** register is the 4-mA drive control register. Each GPIO signal in the port can be individually configured without affecting the other pads. When setting the **DRV4** bit for a GPIO signal, the corresponding **DRV2** bit in the **GPIODR2R** register and **DRV8** bit in the **GPIODR8R** register are automatically cleared by hardware.

Note: This register has no effect on port pins **PL6** and **PL7**.

GPIO 4-mA Drive Select (GPIODR4R)

GPIO Port A (AHB) base: 0x4005.8000
 GPIO Port B (AHB) base: 0x4005.9000
 GPIO Port C (AHB) base: 0x4005.A000
 GPIO Port D (AHB) base: 0x4005.B000
 GPIO Port E (AHB) base: 0x4005.C000
 GPIO Port F (AHB) base: 0x4005.D000
 GPIO Port G (AHB) base: 0x4005.E000
 GPIO Port H (AHB) base: 0x4005.F000
 GPIO Port J (AHB) base: 0x4006.0000
 GPIO Port K (AHB) base: 0x4006.1000
 GPIO Port L (AHB) base: 0x4006.2000
 GPIO Port M (AHB) base: 0x4006.3000
 GPIO Port N (AHB) base: 0x4006.4000
 GPIO Port P (AHB) base: 0x4006.5000
 GPIO Port Q (AHB) base: 0x4006.6000
 Offset 0x504
 Type RW, reset 0x0000.0000

	31	30	29	28	27	26	25	24	23	22	21	20	19	18	17	16
	reserved															
Type	RO	RO	RO	RO	RO	RO	RO	RO	RO	RO	RO	RO	RO	RO	RO	RO
Reset	0	0	0	0	0	0	0	0	0	0	0	0	0	0	0	0
	15	14	13	12	11	10	9	8	7	6	5	4	3	2	1	0
	reserved								DRV4							
Type	RO	RO	RO	RO	RO	RO	RO	RO	RW	RW	RW	RW	RW	RW	RW	RW
Reset	0	0	0	0	0	0	0	0	0	0	0	0	0	0	0	0

Bit/Field	Name	Type	Reset	Description
31:8	reserved	RO	0x0000.00	Software should not rely on the value of a reserved bit. To provide compatibility with future products, the value of a reserved bit should be preserved across a read-modify-write operation.
7:0	DRV4	RW	0x00	Output Pad 4-mA Drive Enable

Value	Description
0	The drive for the corresponding GPIO pin is controlled by the GPIODR2R or GPIODR8R register.
1	The corresponding GPIO pin has 4-mA drive.

Setting a bit in either the **GPIODR2** register or the **GPIODR8** register clears the corresponding 4-mA enable bit. The change is effective on the next clock cycle.

Register 13: GPIO 8-mA Drive Select (GPIODR8R), offset 0x508

The **GPIODR8R** register is the 8-mA drive control register. Each GPIO signal in the port can be individually configured without affecting the other pads. When setting the **DRV8** bit for a GPIO signal, the corresponding **DRV2** bit in the **GPIODR2R** register and **DRV4** bit in the **GPIODR4R** register are automatically cleared by hardware. The 8-mA setting is also used for high-current operation.

Note: There is no configuration difference between 8-mA and high-current operation. The additional current capacity results from a shift in the V_{OH}/V_{OL} levels. See “Recommended Operating Conditions” on page 1944 for further information.

Note: This register has no effect on port pins **PL6** and **PL7**.

GPIO 8-mA Drive Select (GPIODR8R)

GPIO Port A (AHB) base: 0x4005.8000
 GPIO Port B (AHB) base: 0x4005.9000
 GPIO Port C (AHB) base: 0x4005.A000
 GPIO Port D (AHB) base: 0x4005.B000
 GPIO Port E (AHB) base: 0x4005.C000
 GPIO Port F (AHB) base: 0x4005.D000
 GPIO Port G (AHB) base: 0x4005.E000
 GPIO Port H (AHB) base: 0x4005.F000
 GPIO Port J (AHB) base: 0x4006.0000
 GPIO Port K (AHB) base: 0x4006.1000
 GPIO Port L (AHB) base: 0x4006.2000
 GPIO Port M (AHB) base: 0x4006.3000
 GPIO Port N (AHB) base: 0x4006.4000
 GPIO Port P (AHB) base: 0x4006.5000
 GPIO Port Q (AHB) base: 0x4006.6000
 Offset 0x508
 Type RW, reset 0x0000.0000

	31	30	29	28	27	26	25	24	23	22	21	20	19	18	17	16
	reserved															
Type	RO	RO	RO	RO	RO	RO	RO	RO	RO	RO	RO	RO	RO	RO	RO	RO
Reset	0	0	0	0	0	0	0	0	0	0	0	0	0	0	0	0
	15	14	13	12	11	10	9	8	7	6	5	4	3	2	1	0
	reserved								DRV8							
Type	RO	RO	RO	RO	RO	RO	RO	RO	RW	RW	RW	RW	RW	RW	RW	RW
Reset	0	0	0	0	0	0	0	0	0	0	0	0	0	0	0	0

Bit/Field	Name	Type	Reset	Description
31:8	reserved	RO	0x0000.00	Software should not rely on the value of a reserved bit. To provide compatibility with future products, the value of a reserved bit should be preserved across a read-modify-write operation.
7:0	DRV8	RW	0x00	Output Pad 8-mA Drive Enable

Value	Description
0	The drive for the corresponding GPIO pin is controlled by the GPIODR2R or GPIODR4R register.
1	The corresponding GPIO pin has 8-mA drive.

Setting a bit in either the **GPIODR2** register or the **GPIODR4** register clears the corresponding 8-mA enable bit. The change is effective on the next clock cycle.

Register 14: GPIO Open Drain Select (GPIODR), offset 0x50C

The **GPIODR** register is the open drain control register. Setting a bit in this register enables the open-drain configuration of the corresponding GPIO pad. When open-drain mode is enabled, the corresponding bit should also be set in the **GPIO Digital Enable (GPIODEN)** register (see page 789). Corresponding bits in the drive strength and slew rate control registers (**GPIODR2R**, **GPIODR4R**, **GPIODR8R**, and **GPIOSLR**) can be set to achieve the desired fall times. The GPIO acts as an input if the corresponding bit in the **GPIODIR** register is cleared. If open drain is selected while the GPIO is configured as an input, the GPIO will remain an input and the open-drain selection has no effect until the GPIO is changed to an output.

When using the I²C module, in addition to configuring the data pin to open drain, the **GPIO Alternate Function Select (GPIOAFSEL)** register bits for the I²C clock and data pins should be set (see examples in “Initialization and Configuration” on page 761).

Note: This register has no effect on port pins PL6 and PL7.

GPIO Open Drain Select (GPIODR)

GPIO Port A (AHB) base: 0x4005.8000
 GPIO Port B (AHB) base: 0x4005.9000
 GPIO Port C (AHB) base: 0x4005.A000
 GPIO Port D (AHB) base: 0x4005.B000
 GPIO Port E (AHB) base: 0x4005.C000
 GPIO Port F (AHB) base: 0x4005.D000
 GPIO Port G (AHB) base: 0x4005.E000
 GPIO Port H (AHB) base: 0x4005.F000
 GPIO Port J (AHB) base: 0x4006.0000
 GPIO Port K (AHB) base: 0x4006.1000
 GPIO Port L (AHB) base: 0x4006.2000
 GPIO Port M (AHB) base: 0x4006.3000
 GPIO Port N (AHB) base: 0x4006.4000
 GPIO Port P (AHB) base: 0x4006.5000
 GPIO Port Q (AHB) base: 0x4006.6000
 Offset 0x50C

Type RW, reset 0x0000.0000

	31	30	29	28	27	26	25	24	23	22	21	20	19	18	17	16
	reserved															
Type	RO	RO	RO	RO	RO	RO	RO	RO	RO	RO	RO	RO	RO	RO	RO	RO
Reset	0	0	0	0	0	0	0	0	0	0	0	0	0	0	0	0
	15	14	13	12	11	10	9	8	7	6	5	4	3	2	1	0
	reserved								ODE							
Type	RO	RO	RO	RO	RO	RO	RO	RO	RW	RW	RW	RW	RW	RW	RW	RW
Reset	0	0	0	0	0	0	0	0	0	0	0	0	0	0	0	0

Bit/Field	Name	Type	Reset	Description
31:8	reserved	RO	0x0000.00	Software should not rely on the value of a reserved bit. To provide compatibility with future products, the value of a reserved bit should be preserved across a read-modify-write operation.
7:0	ODE	RW	0x00	Output Pad Open Drain Enable
	Value	Description		
	0	The corresponding pin is not configured as open drain.		
	1	The corresponding pin is configured as open drain.		

Register 15: GPIO Pull-Up Select (GPIOPUR), offset 0x510

The **GPIOPUR** register is the pull-up control register. When a bit is set, a weak pull-up resistor on the corresponding GPIO signal is enabled. Setting a bit in **GPIOPUR** automatically clears the corresponding bit in the **GPIO Pull-Down Select (GPIOPDR)** register (see page 786). Write access to this register is protected with the **GPIOCR** register. Bits in **GPIOCR** that are cleared prevent writes to the equivalent bit in this register.

Important: The table below shows special consideration GPIO pins. Most GPIO pins are configured as GPIOs and tri-stated by default (**GPIOAFSEL**=0, **GPIODEN**=0, **GPIOPDR**=0, **GPIOPUR**=0, and **GPIOCTL**=0). Special consideration pins may be programmed to a non-GPIO function or may have special commit controls out of reset. In addition, a Power-On-Reset (\overline{POR}) returns these GPIO to their original special consideration state.

Table 10-9. GPIO Pins With Special Considerations

GPIO Pins	Default Reset State	GPIOAFSEL	GPIODEN	GPIOPDR	GPIOPUR	GPIOCTL	GPIOCR
PC[3:0]	JTAG/SWD	1	1	0	1	0x1	0
PD[7]	GPIO ^a	0	0	0	0	0x0	0
PE[7]	GPIO ^a	0	0	0	0	0x0	0

a. This pin is configured as a GPIO by default but is locked and can only be reprogrammed by unlocking the pin in the **GPIOLOCK** register and uncommitting it by setting the **GPIOCR** register.

The GPIO commit control registers provide a layer of protection against accidental programming of critical hardware signals including the GPIO pins that can function as JTAG/SWD signals and the **NMI** signal. The commit control process must be followed for these pins, even if they are programmed as alternate functions other than JTAG/SWD or **NMI**; see “Commit Control” on page 760.

Note: If the device fails initialization during reset, the hardware toggles the **TDO** output as an indication of failure. Thus, during board layout, designers should not designate the **TDO** pin as a GPIO in sensitive applications where the possibility of toggling could affect the design.

Note: The GPIO commit control registers provide a layer of protection against accidental programming of critical hardware peripherals. Protection is provided for the GPIO pins that can be used as the four JTAG/SWD pins and the **NMI** pin (see “Signal Tables” on page 1896 for pin numbers). Writes to protected bits of the **GPIO Alternate Function Select (GPIOAFSEL)** register (see page 778), **GPIO Pull Up Select (GPIOPUR)** register (see page 784), **GPIO Pull-Down Select (GPIOPDR)** register (see page 786), and **GPIO Digital Enable (GPIODEN)** register (see page 789) are not committed to storage unless the **GPIO Lock (GPIOLOCK)** register (see page 791) has been unlocked and the appropriate bits of the **GPIO Commit (GPIOCR)** register (see page 792) have been set.

GPIO Pull-Up Select (GPIOPUR)

GPIO Port A (AHB) base: 0x4005.8000
 GPIO Port B (AHB) base: 0x4005.9000
 GPIO Port C (AHB) base: 0x4005.A000
 GPIO Port D (AHB) base: 0x4005.B000
 GPIO Port E (AHB) base: 0x4005.C000
 GPIO Port F (AHB) base: 0x4005.D000
 GPIO Port G (AHB) base: 0x4005.E000
 GPIO Port H (AHB) base: 0x4005.F000
 GPIO Port J (AHB) base: 0x4006.0000
 GPIO Port K (AHB) base: 0x4006.1000
 GPIO Port L (AHB) base: 0x4006.2000
 GPIO Port M (AHB) base: 0x4006.3000
 GPIO Port N (AHB) base: 0x4006.4000
 GPIO Port P (AHB) base: 0x4006.5000
 GPIO Port Q (AHB) base: 0x4006.6000

Offset 0x510

Type RW, reset -

	31	30	29	28	27	26	25	24	23	22	21	20	19	18	17	16
	reserved															
Type	RO	RO	RO	RO	RO	RO	RO	RO	RO	RO	RO	RO	RO	RO	RO	RO
Reset	0	0	0	0	0	0	0	0	0	0	0	0	0	0	0	0
	15	14	13	12	11	10	9	8	7	6	5	4	3	2	1	0
	reserved								PUE							
Type	RO	RO	RO	RO	RO	RO	RO	RO	RW	RW	RW	RW	RW	RW	RW	RW
Reset	0	0	0	0	0	0	0	0	-	-	-	-	-	-	-	-

Bit/Field	Name	Type	Reset	Description
31:8	reserved	RO	0x0000.00	Software should not rely on the value of a reserved bit. To provide compatibility with future products, the value of a reserved bit should be preserved across a read-modify-write operation.
7:0	PUE	RW	-	Pad Weak Pull-Up Enable

Value Description

Value	Description
0	The corresponding pin's weak pull-up resistor is disabled.
1	The corresponding pin's weak pull-up resistor is enabled.

Setting a bit in the **GPIOPDR** register clears the corresponding bit in the **GPIOPUR** register. The change is effective on the next clock cycle. The reset value for this register is 0x0000.0000 for GPIO ports that are not listed in Table 10-1 on page 751.

Register 16: GPIO Pull-Down Select (GPIOPDR), offset 0x514

The **GPIOPDR** register is the pull-down control register. When a bit is set, a weak pull-down resistor on the corresponding GPIO signal is enabled. Setting a bit in **GPIOPDR** automatically clears the corresponding bit in the **GPIO Pull-Up Select (GPIOPUR)** register (see page 784).

Important: The table below shows special consideration GPIO pins. Most GPIO pins are configured as GPIOs and tri-stated by default (**GPIOAFSEL**=0, **GPIODEN**=0, **GPIOPDR**=0, **GPIOPUR**=0, and **GPIOCTL**=0). Special consideration pins may be programmed to a non-GPIO function or may have special commit controls out of reset. In addition, a Power-On-Reset (\overline{POR}) returns these GPIO to their original special consideration state.

Table 10-10. GPIO Pins With Special Considerations

GPIO Pins	Default Reset State	GPIOAFSEL	GPIODEN	GPIOPDR	GPIOPUR	GPIOCTL	GPIOCR
PC[3:0]	JTAG/SWD	1	1	0	1	0x1	0
PD[7]	GPIO ^a	0	0	0	0	0x0	0
PE[7]	GPIO ^a	0	0	0	0	0x0	0

a. This pin is configured as a GPIO by default but is locked and can only be reprogrammed by unlocking the pin in the **GPIOLOCK** register and uncommitting it by setting the **GPIOCR** register.

The GPIO commit control registers provide a layer of protection against accidental programming of critical hardware signals including the GPIO pins that can function as JTAG/SWD signals and the **NMI** signal. The commit control process must be followed for these pins, even if they are programmed as alternate functions other than JTAG/SWD or **NMI**; see “Commit Control” on page 760.

Note: If the device fails initialization during reset, the hardware toggles the **TDO** output as an indication of failure. Thus, during board layout, designers should not designate the **TDO** pin as a GPIO in sensitive applications where the possibility of toggling could affect the design.

Note: The GPIO commit control registers provide a layer of protection against accidental programming of critical hardware peripherals. Protection is provided for the GPIO pins that can be used as the four JTAG/SWD pins and the **NMI** pin (see “Signal Tables” on page 1896 for pin numbers). Writes to protected bits of the **GPIO Alternate Function Select (GPIOAFSEL)** register (see page 778), **GPIO Pull Up Select (GPIOPUR)** register (see page 784), **GPIO Pull-Down Select (GPIOPDR)** register (see page 786), and **GPIO Digital Enable (GPIODEN)** register (see page 789) are not committed to storage unless the **GPIO Lock (GPIOLOCK)** register (see page 791) has been unlocked and the appropriate bits of the **GPIO Commit (GPIOCR)** register (see page 792) have been set.

GPIO Pull-Down Select (GPIOPDR)

GPIO Port A (AHB) base: 0x4005.8000
 GPIO Port B (AHB) base: 0x4005.9000
 GPIO Port C (AHB) base: 0x4005.A000
 GPIO Port D (AHB) base: 0x4005.B000
 GPIO Port E (AHB) base: 0x4005.C000
 GPIO Port F (AHB) base: 0x4005.D000
 GPIO Port G (AHB) base: 0x4005.E000
 GPIO Port H (AHB) base: 0x4005.F000
 GPIO Port J (AHB) base: 0x4006.0000
 GPIO Port K (AHB) base: 0x4006.1000
 GPIO Port L (AHB) base: 0x4006.2000
 GPIO Port M (AHB) base: 0x4006.3000
 GPIO Port N (AHB) base: 0x4006.4000
 GPIO Port P (AHB) base: 0x4006.5000
 GPIO Port Q (AHB) base: 0x4006.6000

Offset 0x514

Type RW, reset 0x0000.0000

	31	30	29	28	27	26	25	24	23	22	21	20	19	18	17	16
	reserved															
Type	RO	RO	RO	RO	RO	RO	RO	RO	RO	RO	RO	RO	RO	RO	RO	RO
Reset	0	0	0	0	0	0	0	0	0	0	0	0	0	0	0	0
	15	14	13	12	11	10	9	8	7	6	5	4	3	2	1	0
	reserved								PDE							
Type	RO	RO	RO	RO	RO	RO	RO	RO	RW	RW	RW	RW	RW	RW	RW	RW
Reset	0	0	0	0	0	0	0	0	0	0	0	0	0	0	0	0

Bit/Field	Name	Type	Reset	Description
31:8	reserved	RO	0x0000.00	Software should not rely on the value of a reserved bit. To provide compatibility with future products, the value of a reserved bit should be preserved across a read-modify-write operation.
7:0	PDE	RW	0x00	Pad Weak Pull-Down Enable

Value Description

0	The corresponding pin's weak pull-down resistor is disabled.
1	The corresponding pin's weak pull-down resistor is enabled.

Setting a bit in the **GPIOPUR** register clears the corresponding bit in the **GPIOPDR** register. The change is effective on the next clock cycle.

Register 17: GPIO Slew Rate Control Select (GPIOSLR), offset 0x518

The **GPIOSLR** register is the slew rate control register. Slew rate control is only available when using the 8-mA, 10-mA or 12-mA drive strength option. The selection of drive strength is done through the **GPIO Drive Select (GPIODRnR** registers and the **GPIO Peripheral Configuration (GPIOPC)** register.

Note: This register has no effect on port pins **PL6** and **PL7**.

GPIO Slew Rate Control Select (GPIOSLR)

GPIO Port A (AHB) base: 0x4005.8000
 GPIO Port B (AHB) base: 0x4005.9000
 GPIO Port C (AHB) base: 0x4005.A000
 GPIO Port D (AHB) base: 0x4005.B000
 GPIO Port E (AHB) base: 0x4005.C000
 GPIO Port F (AHB) base: 0x4005.D000
 GPIO Port G (AHB) base: 0x4005.E000
 GPIO Port H (AHB) base: 0x4005.F000
 GPIO Port J (AHB) base: 0x4006.0000
 GPIO Port K (AHB) base: 0x4006.1000
 GPIO Port L (AHB) base: 0x4006.2000
 GPIO Port M (AHB) base: 0x4006.3000
 GPIO Port N (AHB) base: 0x4006.4000
 GPIO Port P (AHB) base: 0x4006.5000
 GPIO Port Q (AHB) base: 0x4006.6000

Offset 0x518
 Type RW, reset 0x0000.0000

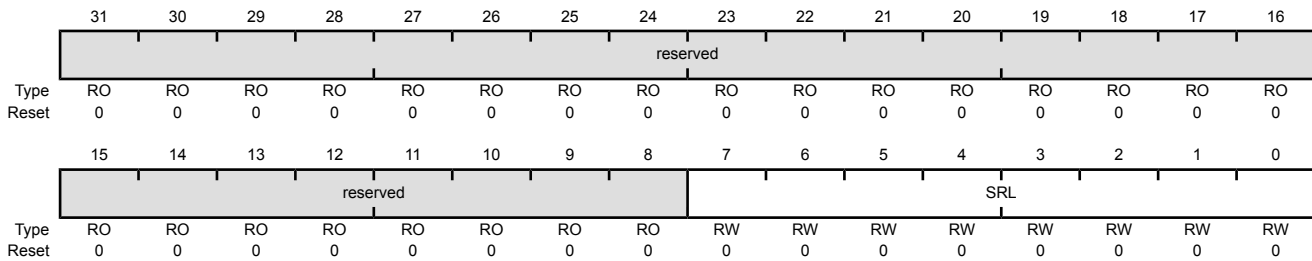

Bit/Field	Name	Type	Reset	Description
31:8	reserved	RO	0x0000.00	Software should not rely on the value of a reserved bit. To provide compatibility with future products, the value of a reserved bit should be preserved across a read-modify-write operation.
7:0	SRL	RW	0x00	Slew Rate Limit Enable (8-mA, 10-mA and 12-mA drive only)

Value	Description
0	Slew rate control is disabled for the corresponding pin.
1	Slew rate control is enabled for the corresponding pin.

Register 18: GPIO Digital Enable (GPIODEN), offset 0x51C

Note: Pins configured as digital inputs are Schmitt-triggered.

The **GPIODEN** register is the digital enable register. By default, all GPIO signals except those listed below are configured out of reset to be undriven (tristate). Their digital function is disabled; they do not drive a logic value on the pin and they do not allow the pin voltage into the GPIO receiver. To use the pin as a digital input or output (either GPIO or alternate function), the corresponding **GPIODEN** bit must be set.

Important: The table below shows special consideration GPIO pins. Most GPIO pins are configured as GPIOs and tri-stated by default (**GPIODEN**=0, **GPIODEN**=0, **GPIOPDR**=0, **GPIOPUR**=0, and **GPIOPCTL**=0). Special consideration pins may be programmed to a non-GPIO function or may have special commit controls out of reset. In addition, a Power-On-Reset (\overline{POR}) returns these GPIO to their original special consideration state.

Table 10-11. GPIO Pins With Special Considerations

GPIO Pins	Default Reset State	GPIODEN	GPIODEN	GPIOPDR	GPIOPUR	GPIOPCTL	GPIOCR
PC[3:0]	JTAG/SWD	1	1	0	1	0x1	0
PD[7]	GPIO ^a	0	0	0	0	0x0	0
PE[7]	GPIO ^a	0	0	0	0	0x0	0

a. This pin is configured as a GPIO by default but is locked and can only be reprogrammed by unlocking the pin in the **GPIOLOCK** register and uncommitting it by setting the **GPIOCR** register.

The GPIO commit control registers provide a layer of protection against accidental programming of critical hardware signals including the GPIO pins that can function as JTAG/SWD signals and the **NMI** signal. The commit control process must be followed for these pins, even if they are programmed as alternate functions other than JTAG/SWD or **NMI**; see “Commit Control” on page 760.

Note: If the device fails initialization during reset, the hardware toggles the **TDO** output as an indication of failure. Thus, during board layout, designers should not designate the **TDO** pin as a GPIO in sensitive applications where the possibility of toggling could affect the design.

Note: The GPIO commit control registers provide a layer of protection against accidental programming of critical hardware peripherals. Protection is provided for the GPIO pins that can be used as the four JTAG/SWD pins and the **NMI** pin (see “Signal Tables” on page 1896 for pin numbers). Writes to protected bits of the **GPIO Alternate Function Select (GPIODEN)** register (see page 778), **GPIO Pull Up Select (GPIOPUR)** register (see page 784), **GPIO Pull-Down Select (GPIOPDR)** register (see page 786), and **GPIO Digital Enable (GPIODEN)** register (see page 789) are not committed to storage unless the **GPIO Lock (GPIOLOCK)** register (see page 791) has been unlocked and the appropriate bits of the **GPIO Commit (GPIOCR)** register (see page 792) have been set.

GPIO Digital Enable (GPIODEN)

GPIO Port A (AHB) base: 0x4005.8000
 GPIO Port B (AHB) base: 0x4005.9000
 GPIO Port C (AHB) base: 0x4005.A000
 GPIO Port D (AHB) base: 0x4005.B000
 GPIO Port E (AHB) base: 0x4005.C000
 GPIO Port F (AHB) base: 0x4005.D000
 GPIO Port G (AHB) base: 0x4005.E000
 GPIO Port H (AHB) base: 0x4005.F000
 GPIO Port J (AHB) base: 0x4006.0000
 GPIO Port K (AHB) base: 0x4006.1000
 GPIO Port L (AHB) base: 0x4006.2000
 GPIO Port M (AHB) base: 0x4006.3000
 GPIO Port N (AHB) base: 0x4006.4000
 GPIO Port P (AHB) base: 0x4006.5000
 GPIO Port Q (AHB) base: 0x4006.6000
 Offset 0x51C
 Type RW, reset -

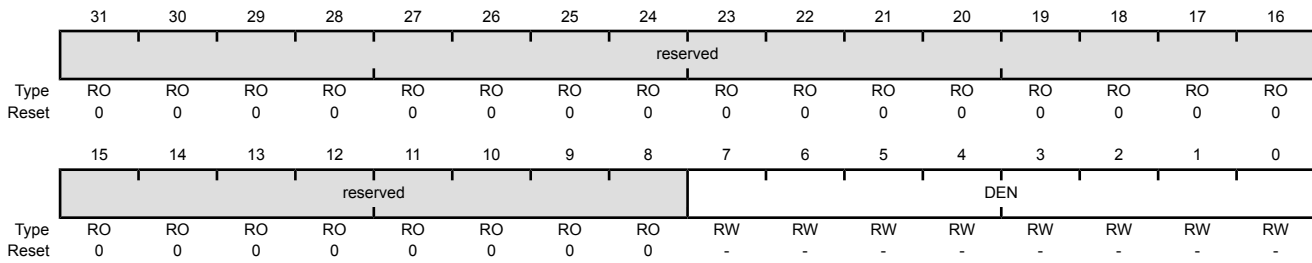

Bit/Field	Name	Type	Reset	Description
31:8	reserved	RO	0x0000.00	Software should not rely on the value of a reserved bit. To provide compatibility with future products, the value of a reserved bit should be preserved across a read-modify-write operation.
7:0	DEN	RW	-	Digital Enable

Value	Description
0	The digital functions for the corresponding pin are disabled.
1	The digital functions for the corresponding pin are enabled.

The reset value for this register is 0x0000.0000 for GPIO ports that are not listed in Table 10-1 on page 751.

Register 19: GPIO Lock (GPIOLOCK), offset 0x520

The **GPIOLOCK** register enables write access to the **GPIOCR** register (see page 792). Writing 0x4C4F.434B to the **GPIOLOCK** register unlocks the **GPIOCR** register. Writing any other value to the **GPIOLOCK** register re-enables the locked state. Reading the **GPIOLOCK** register returns the lock status rather than the 32-bit value that was previously written. Therefore, when write accesses are disabled, or locked, reading the **GPIOLOCK** register returns 0x0000.0001. When write accesses are enabled, or unlocked, reading the **GPIOLOCK** register returns 0x0000.0000.

GPIO Lock (GPIOLOCK)

GPIO Port A (AHB) base: 0x4005.8000
 GPIO Port B (AHB) base: 0x4005.9000
 GPIO Port C (AHB) base: 0x4005.A000
 GPIO Port D (AHB) base: 0x4005.B000
 GPIO Port E (AHB) base: 0x4005.C000
 GPIO Port F (AHB) base: 0x4005.D000
 GPIO Port G (AHB) base: 0x4005.E000
 GPIO Port H (AHB) base: 0x4005.F000
 GPIO Port J (AHB) base: 0x4006.0000
 GPIO Port K (AHB) base: 0x4006.1000
 GPIO Port L (AHB) base: 0x4006.2000
 GPIO Port M (AHB) base: 0x4006.3000
 GPIO Port N (AHB) base: 0x4006.4000
 GPIO Port P (AHB) base: 0x4006.5000
 GPIO Port Q (AHB) base: 0x4006.6000
 Offset 0x520

Type RW, reset 0x0000.0001

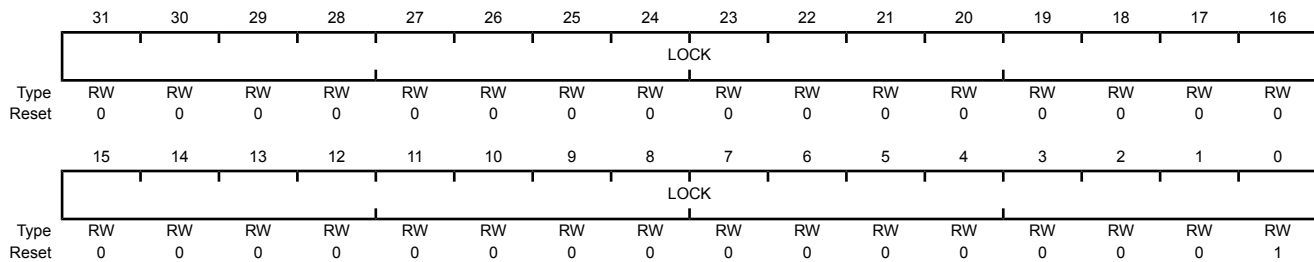

Bit/Field	Name	Type	Reset	Description
31:0	LOCK	RW	0x0000.0001	GPIO Lock

A write of the value 0x4C4F.434B unlocks the **GPIO Commit (GPIOCR)** register for write access. A write of any other value or a write to the **GPIOCR** register reapplies the lock, preventing any register updates.

A read of this register returns the following values:

Value Description

0x1 The **GPIOCR** register is locked and may not be modified.

0x0 The **GPIOCR** register is unlocked and may be modified.

Register 20: GPIO Commit (GPIOCR), offset 0x524

The **GPIOCR** register is the commit register. The value of the **GPIOCR** register determines which bits of the **GPIOAFSEL**, **GPIOPUR**, **GPIOPDR**, and **GPIONEN** registers are committed when a write to these registers is performed. If a bit in the **GPIOCR** register is cleared, the data being written to the corresponding bit in the **GPIOAFSEL**, **GPIOPUR**, **GPIOPDR**, or **GPIONEN** registers cannot be committed and retains its previous value. If a bit in the **GPIOCR** register is set, the data being written to the corresponding bit of the **GPIOAFSEL**, **GPIOPUR**, **GPIOPDR**, or **GPIONEN** registers is committed to the register and reflects the new value.

The contents of the **GPIOCR** register can only be modified if the status in the **GPIOLOCK** register is unlocked. Writes to the **GPIOCR** register are ignored if the status in the **GPIOLOCK** register is locked.

Important: This register is designed to prevent accidental programming of the registers that control connectivity to the NMI and JTAG/SWD debug hardware. By initializing the bits of the **GPIOCR** register to 0 for the NMI and JTAG/SWD pins (see “Signal Tables” on page 1896 for pin numbers), the NMI and JTAG/SWD debug port can only be converted to GPIOs through a deliberate set of writes to the **GPIOLOCK**, **GPIOCR**, and the corresponding registers.

Because this protection is currently only implemented on the NMI and JTAG/SWD pins (see “Signal Tables” on page 1896 for pin numbers), all of the other bits in the **GPIOCR** registers cannot be written with 0x0. These bits are hardwired to 0x1, ensuring that it is always possible to commit new values to the **GPIOAFSEL**, **GPIOPUR**, **GPIOPDR**, or **GPIONEN** register bits of these other pins.

GPIO Commit (GPIOCR)

GPIO Port A (AHB) base: 0x4005.8000
 GPIO Port B (AHB) base: 0x4005.9000
 GPIO Port C (AHB) base: 0x4005.A000
 GPIO Port D (AHB) base: 0x4005.B000
 GPIO Port E (AHB) base: 0x4005.C000
 GPIO Port F (AHB) base: 0x4005.D000
 GPIO Port G (AHB) base: 0x4005.E000
 GPIO Port H (AHB) base: 0x4005.F000
 GPIO Port J (AHB) base: 0x4006.0000
 GPIO Port K (AHB) base: 0x4006.1000
 GPIO Port L (AHB) base: 0x4006.2000
 GPIO Port M (AHB) base: 0x4006.3000
 GPIO Port N (AHB) base: 0x4006.4000
 GPIO Port P (AHB) base: 0x4006.5000
 GPIO Port Q (AHB) base: 0x4006.6000
 Offset 0x524
 Type -, reset -

	31	30	29	28	27	26	25	24	23	22	21	20	19	18	17	16
	reserved															
Type	RO	RO	RO	RO	RO	RO	RO	RO	RO	RO	RO	RO	RO	RO	RO	RO
Reset	0	0	0	0	0	0	0	0	0	0	0	0	0	0	0	0
	15	14	13	12	11	10	9	8	7	6	5	4	3	2	1	0
	reserved								CR							
Type	RO	RO	RO	RO	RO	RO	RO	RO	-	-	-	-	-	-	-	-
Reset	0	0	0	0	0	0	0	0	-	-	-	-	-	-	-	-

Bit/Field	Name	Type	Reset	Description
31:8	reserved	RO	0x0000.00	Software should not rely on the value of a reserved bit. To provide compatibility with future products, the value of a reserved bit should be preserved across a read-modify-write operation.

Bit/Field	Name	Type	Reset	Description
7:0	CR	-	-	GPIO Commit
				Value Description
			0	The corresponding GPIODEN , GPIOPUR , GPIOPDR , or GPIODEN bits cannot be written.
			1	The corresponding GPIODEN , GPIOPUR , GPIOPDR , or GPIODEN bits can be written.
			Note:	The default register type for the GPIOCR register is RO for all GPIO pins with the exception of the NMI pin and the four JTAG/SWD pins (see "Signal Tables" on page 1896 for pin numbers). These six pins are the only GPIOs that are protected by the GPIOCR register. Because of this, the register type for the corresponding GPIO Ports is RW.
				The default reset value for the GPIOCR register is 0x0000.00FF for all GPIO pins, with the exception of the NMI and JTAG/SWD pins (see "Signal Tables" on page 1896 for pin numbers). To ensure that the JTAG and NMI pins are not accidentally programmed as GPIO pins, these pins default to non-committable. Because of this, the default reset value of GPIOCR changes for the corresponding ports.

Register 21: GPIO Analog Mode Select (GPIOAMSEL), offset 0x528

Important: This register is only valid for ports and pins that can be used as ADC AINx inputs.

If any pin is to be used as an ADC input, the appropriate bit in **GPIOAMSEL** must be set to disable the analog isolation circuit.

The **GPIOAMSEL** register controls isolation circuits to the analog side of a unified I/O pad. Because the GPIOs may be driven by a 3.3-V source and affect analog operation, analog circuitry requires isolation from the pins when they are not used in their analog function.

Each bit of this register controls the isolation circuitry for the corresponding GPIO signal. For information on which GPIO pins can be used for ADC functions, refer to Table 29-5 on page 1932.

GPIO Analog Mode Select (GPIOAMSEL)

GPIO Port A (AHB) base: 0x4005.8000
 GPIO Port B (AHB) base: 0x4005.9000
 GPIO Port C (AHB) base: 0x4005.A000
 GPIO Port D (AHB) base: 0x4005.B000
 GPIO Port E (AHB) base: 0x4005.C000
 GPIO Port F (AHB) base: 0x4005.D000
 GPIO Port G (AHB) base: 0x4005.E000
 GPIO Port H (AHB) base: 0x4005.F000
 GPIO Port J (AHB) base: 0x4006.0000
 GPIO Port K (AHB) base: 0x4006.1000
 GPIO Port L (AHB) base: 0x4006.2000
 GPIO Port M (AHB) base: 0x4006.3000
 GPIO Port N (AHB) base: 0x4006.4000
 GPIO Port P (AHB) base: 0x4006.5000
 GPIO Port Q (AHB) base: 0x4006.6000
 Offset 0x528
 Type RW, reset 0x0000.0000

	31	30	29	28	27	26	25	24	23	22	21	20	19	18	17	16
	reserved															
Type	RO	RO	RO	RO	RO	RO	RO	RO	RO	RO	RO	RO	RO	RO	RO	RO
Reset	0	0	0	0	0	0	0	0	0	0	0	0	0	0	0	0
	15	14	13	12	11	10	9	8	7	6	5	4	3	2	1	0
	reserved								GPIOAMSEL							
Type	RO	RO	RO	RO	RO	RO	RO	RO	RW	RW	RW	RW	RW	RW	RW	RW
Reset	0	0	0	0	0	0	0	0	0	0	0	0	0	0	0	0

Bit/Field	Name	Type	Reset	Description
31:8	reserved	RO	0x0000.00	Software should not rely on the value of a reserved bit. To provide compatibility with future products, the value of a reserved bit should be preserved across a read-modify-write operation.
7:0	GPIOAMSEL	RW	0x00	GPIO Analog Mode Select

Value	Description
0	The analog function of the pin is disabled, the isolation is enabled, and the pin is capable of digital functions as specified by the other GPIO configuration registers.
1	The analog function of the pin is enabled, the isolation is disabled, and the pin is capable of analog functions.

Note: This register and bits are only valid for GPIO signals that share analog function through a unified I/O pad.

The reset state of this register is 0 for all signals.

Register 22: GPIO Port Control (GPIOPCTL), offset 0x52C

The **GPIOPCTL** register is used in conjunction with the **GPIOAFSEL** register and selects the specific peripheral signal for each GPIO pin when using the alternate function mode. Most bits in the **GPIOAFSEL** register are cleared on reset, therefore most GPIO pins are configured as GPIOs by default. When a bit is set in the **GPIOAFSEL** register, the corresponding GPIO signal is controlled by an associated peripheral. The **GPIOPCTL** register selects one out of a set of peripheral functions for each GPIO, providing additional flexibility in signal definition. For information on the defined encodings for the bit fields in this register, refer to Table 29-5 on page 1932. The reset value for this register is 0x0000.0000 for GPIO ports that are not listed in the table below.

Note: If a particular input signal to a peripheral is assigned to two different GPIO port pins, the signal is assigned to the port with the lowest letter and the assignment to the higher letter port is ignored. If a particular output signal from a peripheral is assigned to two different GPIO port pins, the signal will output to both pins. Assigning an output signal from a peripheral to two different GPIO pins is not recommended.

Important: The table below shows special consideration GPIO pins. Most GPIO pins are configured as GPIOs and tri-stated by default (**GPIOAFSEL**=0, **GPIODEN**=0, **GPIOPDR**=0, **GPIOPUR**=0, and **GPIOPCTL**=0). Special consideration pins may be programmed to a non-GPIO function or may have special commit controls out of reset. In addition, a Power-On-Reset (\overline{POR}) returns these GPIO to their original special consideration state.

Table 10-12. GPIO Pins With Special Considerations

GPIO Pins	Default Reset State	GPIOAFSEL	GPIODEN	GPIOPDR	GPIOPUR	GPIOPCTL	GPIOCR
PC[3:0]	JTAG/SWD	1	1	0	1	0x1	0
PD[7]	GPIO ^a	0	0	0	0	0x0	0
PE[7]	GPIO ^a	0	0	0	0	0x0	0

a. This pin is configured as a GPIO by default but is locked and can only be reprogrammed by unlocking the pin in the **GPIOLOCK** register and uncommitting it by setting the **GPIOCR** register.

The GPIO commit control registers provide a layer of protection against accidental programming of critical hardware signals including the GPIO pins that can function as JTAG/SWD signals and the **NMI** signal. The commit control process must be followed for these pins, even if they are programmed as alternate functions other than JTAG/SWD or **NMI**; see “Commit Control” on page 760.

Note: If the device fails initialization during reset, the hardware toggles the **TDO** output as an indication of failure. Thus, during board layout, designers should not designate the **TDO** pin as a GPIO in sensitive applications where the possibility of toggling could affect the design.

GPIO Port Control (GPIOPCTL)

GPIO Port A (AHB) base: 0x4005.8000
 GPIO Port B (AHB) base: 0x4005.9000
 GPIO Port C (AHB) base: 0x4005.A000
 GPIO Port D (AHB) base: 0x4005.B000
 GPIO Port E (AHB) base: 0x4005.C000
 GPIO Port F (AHB) base: 0x4005.D000
 GPIO Port G (AHB) base: 0x4005.E000
 GPIO Port H (AHB) base: 0x4005.F000
 GPIO Port J (AHB) base: 0x4006.0000
 GPIO Port K (AHB) base: 0x4006.1000
 GPIO Port L (AHB) base: 0x4006.2000
 GPIO Port M (AHB) base: 0x4006.3000
 GPIO Port N (AHB) base: 0x4006.4000
 GPIO Port P (AHB) base: 0x4006.5000
 GPIO Port Q (AHB) base: 0x4006.6000
 Offset 0x52C
 Type RW, reset -

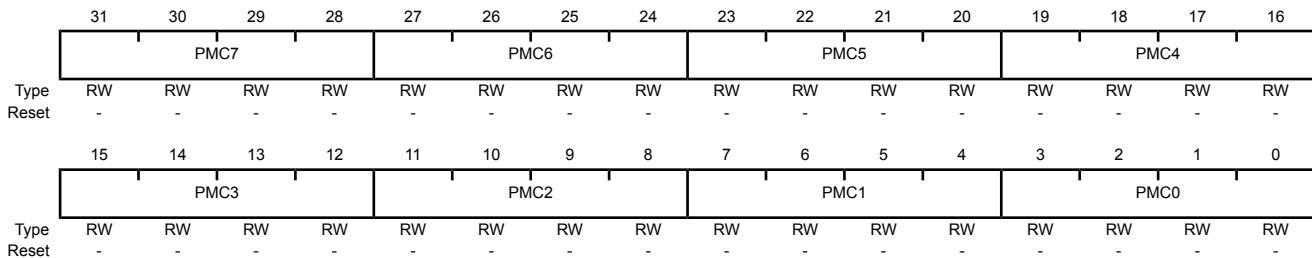

Bit/Field	Name	Type	Reset	Description
31:28	PMC7	RW	-	Port Mux Control 7 This field controls the configuration for GPIO pin 7.
27:24	PMC6	RW	-	Port Mux Control 6 This field controls the configuration for GPIO pin 6.
23:20	PMC5	RW	-	Port Mux Control 5 This field controls the configuration for GPIO pin 5.
19:16	PMC4	RW	-	Port Mux Control 4 This field controls the configuration for GPIO pin 4.
15:12	PMC3	RW	-	Port Mux Control 3 This field controls the configuration for GPIO pin 3.
11:8	PMC2	RW	-	Port Mux Control 2 This field controls the configuration for GPIO pin 2.
7:4	PMC1	RW	-	Port Mux Control 1 This field controls the configuration for GPIO pin 1.
3:0	PMC0	RW	-	Port Mux Control 0 This field controls the configuration for GPIO pin 0.

Register 23: GPIO ADC Control (GPIOADCCTL), offset 0x530

This register is used to configure a GPIO pin as a source for the ADC trigger.

Note that if the Port B **GPIOADCCTL** register is cleared, PB4 can still be used as an external trigger for the ADC. This is a legacy mode which allows code written for previous devices to operate on this microcontroller.

GPIO ADC Control (GPIOADCCTL)

GPIO Port A (AHB) base: 0x4005.8000
 GPIO Port B (AHB) base: 0x4005.9000
 GPIO Port C (AHB) base: 0x4005.A000
 GPIO Port D (AHB) base: 0x4005.B000
 GPIO Port E (AHB) base: 0x4005.C000
 GPIO Port F (AHB) base: 0x4005.D000
 GPIO Port G (AHB) base: 0x4005.E000
 GPIO Port H (AHB) base: 0x4005.F000
 GPIO Port J (AHB) base: 0x4006.0000
 GPIO Port K (AHB) base: 0x4006.1000
 GPIO Port L (AHB) base: 0x4006.2000
 GPIO Port M (AHB) base: 0x4006.3000
 GPIO Port N (AHB) base: 0x4006.4000
 GPIO Port P (AHB) base: 0x4006.5000
 GPIO Port Q (AHB) base: 0x4006.6000
 Offset 0x530
 Type RW, reset 0x0000.0000

	31	30	29	28	27	26	25	24	23	22	21	20	19	18	17	16
	reserved															
Type	RO	RO	RO	RO	RO	RO	RO	RO	RO	RO	RO	RO	RO	RO	RO	RO
Reset	0	0	0	0	0	0	0	0	0	0	0	0	0	0	0	0
	15	14	13	12	11	10	9	8	7	6	5	4	3	2	1	0
	reserved								ADCEN							
Type	RO	RO	RO	RO	RO	RO	RO	RO	RW	RW	RW	RW	RW	RW	RW	RW
Reset	0	0	0	0	0	0	0	0	0	0	0	0	0	0	0	0

Bit/Field	Name	Type	Reset	Description
31:8	reserved	RO	0x0000.00	Software should not rely on the value of a reserved bit. To provide compatibility with future products, the value of a reserved bit should be preserved across a read-modify-write operation.
7:0	ADCEN	RW	0x00	ADC Trigger Enable
				Value Description
				0 The corresponding pin is not used to trigger the ADC.
				1 The corresponding pin is used to trigger the ADC.

Register 24: GPIO DMA Control (GPIODMACTL), offset 0x534

This register is used to configure a GPIO pin as a source for the μ DMA trigger.

GPIO DMA Control (GPIODMACTL)

GPIO Port A (AHB) base: 0x4005.8000
 GPIO Port B (AHB) base: 0x4005.9000
 GPIO Port C (AHB) base: 0x4005.A000
 GPIO Port D (AHB) base: 0x4005.B000
 GPIO Port E (AHB) base: 0x4005.C000
 GPIO Port F (AHB) base: 0x4005.D000
 GPIO Port G (AHB) base: 0x4005.E000
 GPIO Port H (AHB) base: 0x4005.F000
 GPIO Port J (AHB) base: 0x4006.0000
 GPIO Port K (AHB) base: 0x4006.1000
 GPIO Port L (AHB) base: 0x4006.2000
 GPIO Port M (AHB) base: 0x4006.3000
 GPIO Port N (AHB) base: 0x4006.4000
 GPIO Port P (AHB) base: 0x4006.5000
 GPIO Port Q (AHB) base: 0x4006.6000
 Offset 0x534

Type RW, reset 0x0000.0000

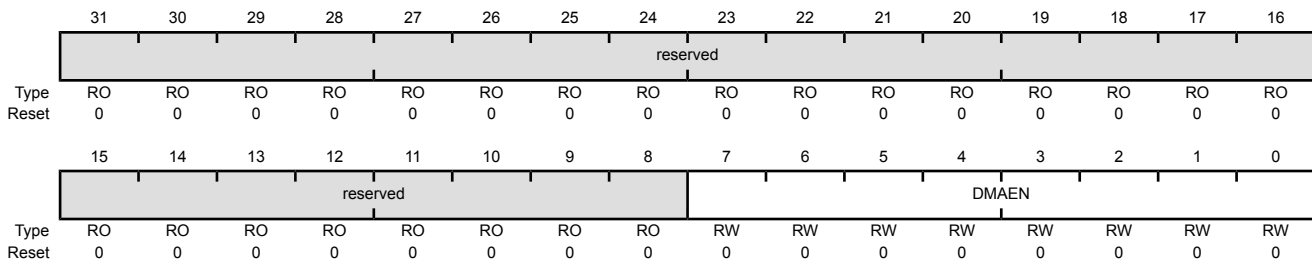

Bit/Field	Name	Type	Reset	Description
31:8	reserved	RO	0x0000.00	Software should not rely on the value of a reserved bit. To provide compatibility with future products, the value of a reserved bit should be preserved across a read-modify-write operation.
7:0	DMAEN	RW	0x00	μ DMA Trigger Enable
				Value Description
			0	The corresponding pin is not used to trigger the μ DMA.
			1	The corresponding pin is used to trigger the μ DMA.

Register 25: GPIO Select Interrupt (GPIOSI), offset 0x538

This register is used to enable individual interrupts for each pin.

Note: This register is only available on Port P and Port Q.

GPIO Select Interrupt (GPIOSI)

GPIO Port A (AHB) base: 0x4005.8000
 GPIO Port B (AHB) base: 0x4005.9000
 GPIO Port C (AHB) base: 0x4005.A000
 GPIO Port D (AHB) base: 0x4005.B000
 GPIO Port E (AHB) base: 0x4005.C000
 GPIO Port F (AHB) base: 0x4005.D000
 GPIO Port G (AHB) base: 0x4005.E000
 GPIO Port H (AHB) base: 0x4005.F000
 GPIO Port J (AHB) base: 0x4006.0000
 GPIO Port K (AHB) base: 0x4006.1000
 GPIO Port L (AHB) base: 0x4006.2000
 GPIO Port M (AHB) base: 0x4006.3000
 GPIO Port N (AHB) base: 0x4006.4000
 GPIO Port P (AHB) base: 0x4006.5000
 GPIO Port Q (AHB) base: 0x4006.6000
 Offset 0x538
 Type RW, reset 0x0000.0000

	31	30	29	28	27	26	25	24	23	22	21	20	19	18	17	16
	reserved															
Type	RO	RO	RO	RO	RO	RO	RO	RO	RO	RO	RO	RO	RO	RO	RO	RO
Reset	0	0	0	0	0	0	0	0	0	0	0	0	0	0	0	0
	15	14	13	12	11	10	9	8	7	6	5	4	3	2	1	0
	reserved															
	SUM															
Type	RO	RO	RO	RO	RO	RO	RO	RO	RO	RO	RO	RO	RO	RO	RO	RW
Reset	0	0	0	0	0	0	0	0	0	0	0	0	0	0	0	0

Bit/Field	Name	Type	Reset	Description
31:1	reserved	RO	0x0000.000	Software should not rely on the value of a reserved bit. To provide compatibility with future products, the value of a reserved bit should be preserved across a read-modify-write operation.
0	SUM	RW	0	Summary Interrupt

Value	Description
0	All port pin interrupts are OR'ed together to produce a summary interrupt.

Note: The OR'ed summary interrupt occurs on bit 0 of the **GPIORIS** register. For summary interrupt mode, software should set the **GPIOIM** register to 0xFF and mask the port pin interrupts 1 through 7 in the **Interrupt Clear Enable (DISn)** register (see “NVIC Register Descriptions” on page 160). When servicing this interrupt, write a 1 to the corresponding bit in the **UNPENDn** register to clear the pending interrupt in the NVIC and clear the **GPIORIS** register pin interrupt bits by setting the **IC** field of the **GPIOICR** register to 0xFF.

1	Each pin has its own interrupt vector.
---	--

Register 26: GPIO 12-mA Drive Select (GPIODR12R), offset 0x53C

The **GPIODR12R** register is the 12-mA drive control register. Each GPIO signal in the port can be individually configured without affecting the other pads.

Note: This register has no effect on port pins **PL6** and **PL7** or **PM[7:4]**.

GPIO 12-mA Drive Select (GPIODR12R)

GPIO Port A (AHB) base: 0x4005.8000
 GPIO Port B (AHB) base: 0x4005.9000
 GPIO Port C (AHB) base: 0x4005.A000
 GPIO Port D (AHB) base: 0x4005.B000
 GPIO Port E (AHB) base: 0x4005.C000
 GPIO Port F (AHB) base: 0x4005.D000
 GPIO Port G (AHB) base: 0x4005.E000
 GPIO Port H (AHB) base: 0x4005.F000
 GPIO Port J (AHB) base: 0x4006.0000
 GPIO Port K (AHB) base: 0x4006.1000
 GPIO Port L (AHB) base: 0x4006.2000
 GPIO Port M (AHB) base: 0x4006.3000
 GPIO Port N (AHB) base: 0x4006.4000
 GPIO Port P (AHB) base: 0x4006.5000
 GPIO Port Q (AHB) base: 0x4006.6000
 Offset 0x53C
 Type RW, reset 0x0000.0000

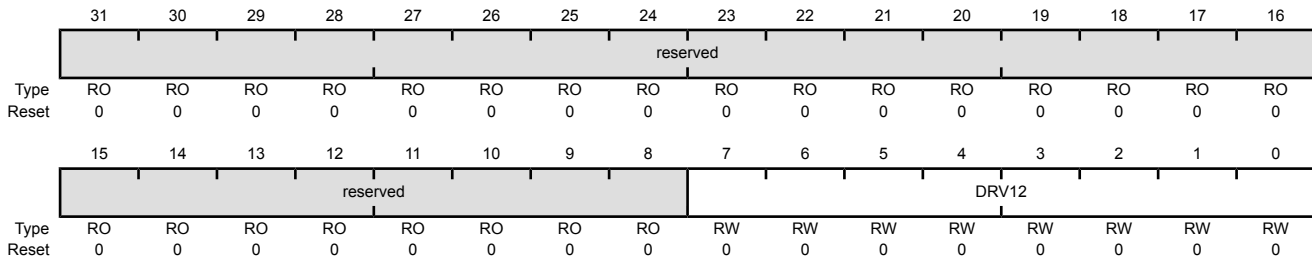

Bit/Field	Name	Type	Reset	Description
31:8	reserved	RO	0x0000.00	Software should not rely on the value of a reserved bit. To provide compatibility with future products, the value of a reserved bit should be preserved across a read-modify-write operation.
7:0	DRV12	RW	0x00	Output Pad 12-mA Drive Enable

Value	Description
0	The drive for the corresponding GPIO pin is controlled by the GPIODR2R , GPIODR4R , and/or the GPIODR8R register.
1	The corresponding GPIO pin has 12-mA drive. This encoding is only valid if the GPIOPP EDE bit is set and the appropriate GPIOPC EDM bit field is programmed to 0x3.

Note: Please refer to Table 10-3 on page 761 for information on how to configure the drive strength.

Changes in the **GPIODR2R**, the **GPIODR4R** register and/or the **GPIODR8R** registers to configure 12 mA are effective on the next clock cycle.

Register 27: GPIO Wake Pin Enable (GPIOWAKEPEN), offset 0x540

This register is used to configure K[7:4] as a wake enable source for the hibernation module. The wake level must be programmed in the **GPIOWAKELVL** register at offset 0x544. In order for this register configuration to become implemented, the **WUUNLK** bit needs to be set in the **HIBIO** register at offset 0x02C in the hibernation module.

Note: This register is only available on Port K.

GPIO Wake Pin Enable (GPIOWAKEPEN)

GPIO Port A (AHB) base: 0x4005.8000
 GPIO Port B (AHB) base: 0x4005.9000
 GPIO Port C (AHB) base: 0x4005.A000
 GPIO Port D (AHB) base: 0x4005.B000
 GPIO Port E (AHB) base: 0x4005.C000
 GPIO Port F (AHB) base: 0x4005.D000
 GPIO Port G (AHB) base: 0x4005.E000
 GPIO Port H (AHB) base: 0x4005.F000
 GPIO Port J (AHB) base: 0x4006.0000
 GPIO Port K (AHB) base: 0x4006.1000
 GPIO Port L (AHB) base: 0x4006.2000
 GPIO Port M (AHB) base: 0x4006.3000
 GPIO Port N (AHB) base: 0x4006.4000
 GPIO Port P (AHB) base: 0x4006.5000
 GPIO Port Q (AHB) base: 0x4006.6000
 Offset 0x540
 Type RW, reset 0x0000.0000

	31	30	29	28	27	26	25	24	23	22	21	20	19	18	17	16
	reserved															
Type	RO	RO	RO	RO	RO	RO	RO	RO	RO	RO	RO	RO	RO	RO	RO	RO
Reset	0	0	0	0	0	0	0	0	0	0	0	0	0	0	0	0
	15	14	13	12	11	10	9	8	7	6	5	4	3	2	1	0
	reserved								WAKEP7	WAKEP6	WAKEP5	WAKEP4	reserved			
Type	RO	RO	RO	RO	RO	RO	RO	RO	RW	RW	RW	RW	RO	RO	RO	RO
Reset	0	0	0	0	0	0	0	0	0	0	0	0	0	0	0	0

Bit/Field	Name	Type	Reset	Description
31:8	reserved	RO	0x0000.000	Software should not rely on the value of a reserved bit. To provide compatibility with future products, the value of a reserved bit should be preserved across a read-modify-write operation.
7	WAKEP7	RW	0	K[7] Wake Enable Value Description 0 Wake-on level is not enabled. 1 Wake-on level is enabled.
6	WAKEP6	RW	0	K[6] Wake Enable Value Description 0 Wake-on level is not enabled. 1 Wake-on level is enabled.

Bit/Field	Name	Type	Reset	Description
5	WAKEP5	RW	0	K[5] Wake Enable Value Description 0 Wake-on level is not enabled. 1 Wake-on level is enabled.
4	WAKEP4	RW	0	K[4] Wake Enable Value Description 0 Wake-on level is not enabled. 1 Wake-on level is enabled.
3:0	reserved	RO	0	Software should not rely on the value of a reserved bit. To provide compatibility with future products, the value of a reserved bit should be preserved across a read-modify-write operation.

Register 28: GPIO Wake Level (GPIOWAKELVL), offset 0x544

This register is used to configure the wake level for K[7:4] in the hibernation module. The wake source must be enabled in the **GPIOWAKEPEN** register at offset 0x540. In order for this register configuration to become implemented, the **WUUNLK** bit needs to be set in the **HIBIO** register at offset 0x02C in the hibernation module.

Note: This register is only available on Port K.

GPIO Wake Level (GPIOWAKELVL)

GPIO Port A (AHB) base: 0x4005.8000
 GPIO Port B (AHB) base: 0x4005.9000
 GPIO Port C (AHB) base: 0x4005.A000
 GPIO Port D (AHB) base: 0x4005.B000
 GPIO Port E (AHB) base: 0x4005.C000
 GPIO Port F (AHB) base: 0x4005.D000
 GPIO Port G (AHB) base: 0x4005.E000
 GPIO Port H (AHB) base: 0x4005.F000
 GPIO Port J (AHB) base: 0x4006.0000
 GPIO Port K (AHB) base: 0x4006.1000
 GPIO Port L (AHB) base: 0x4006.2000
 GPIO Port M (AHB) base: 0x4006.3000
 GPIO Port N (AHB) base: 0x4006.4000
 GPIO Port P (AHB) base: 0x4006.5000
 GPIO Port Q (AHB) base: 0x4006.6000
 Offset 0x544
 Type RW, reset 0x0000.0000

	31	30	29	28	27	26	25	24	23	22	21	20	19	18	17	16
	reserved															
Type	RO	RO	RO	RO	RO	RO	RO	RO	RO	RO	RO	RO	RO	RO	RO	RO
Reset	0	0	0	0	0	0	0	0	0	0	0	0	0	0	0	0
	15	14	13	12	11	10	9	8	7	6	5	4	3	2	1	0
	reserved								WAKELVL7	WAKELVL6	WAKELVL5	WAKELVL4	reserved			
Type	RO	RO	RO	RO	RO	RO	RO	RO	RW	RW	RW	RW	RO	RO	RO	RO
Reset	0	0	0	0	0	0	0	0	0	0	0	0	0	0	0	0

Bit/Field	Name	Type	Reset	Description
31:8	reserved	RO	0x0000.000	Software should not rely on the value of a reserved bit. To provide compatibility with future products, the value of a reserved bit should be preserved across a read-modify-write operation.
7	WAKELVL7	RW	0	K[7] Wake Level Value Description 0 Wake level low 1 Wake level high
6	WAKELVL6	RW	0	K[6] Wake Level Value Description 0 Wake level low 1 Wake level high

Bit/Field	Name	Type	Reset	Description
5	WAKELVL5	RW	0	K[5] Wake Level Value Description 0 Wake level low 1 Wake level high
4	WAKELVL4	RW	0	K[4] Wake Level Value Description 0 Wake level low 1 Wake level high
3:0	reserved	RO	0	Software should not rely on the value of a reserved bit. To provide compatibility with future products, the value of a reserved bit should be preserved across a read-modify-write operation.

Register 29: GPIO Wake Status (GPIOWAKESTAT), offset 0x548

This register indicates the GPIO wake event status. If a register bit has been set for K[7:4], a wake event signal has been sent to the Hibernate module.

Note: This register is only available on Port K.

GPIO Wake Status (GPIOWAKESTAT)

GPIO Port A (AHB) base: 0x4005.8000
 GPIO Port B (AHB) base: 0x4005.9000
 GPIO Port C (AHB) base: 0x4005.A000
 GPIO Port D (AHB) base: 0x4005.B000
 GPIO Port E (AHB) base: 0x4005.C000
 GPIO Port F (AHB) base: 0x4005.D000
 GPIO Port G (AHB) base: 0x4005.E000
 GPIO Port H (AHB) base: 0x4005.F000
 GPIO Port J (AHB) base: 0x4006.0000
 GPIO Port K (AHB) base: 0x4006.1000
 GPIO Port L (AHB) base: 0x4006.2000
 GPIO Port M (AHB) base: 0x4006.3000
 GPIO Port N (AHB) base: 0x4006.4000
 GPIO Port P (AHB) base: 0x4006.5000
 GPIO Port Q (AHB) base: 0x4006.6000
 Offset 0x548
 Type RO, reset 0x0000.0000

	31	30	29	28	27	26	25	24	23	22	21	20	19	18	17	16
	reserved															
Type	RO	RO	RO	RO	RO	RO	RO	RO	RO	RO	RO	RO	RO	RO	RO	RO
Reset	0	0	0	0	0	0	0	0	0	0	0	0	0	0	0	0
	15	14	13	12	11	10	9	8	7	6	5	4	3	2	1	0
	reserved								STAT7	STAT6	STAT5	STAT4	reserved			
Type	RO	RO	RO	RO	RO	RO	RO	RO	RO	RO	RO	RO	RO	RO	RO	RO
Reset	0	0	0	0	0	0	0	0	0	0	0	0	0	0	0	0

Bit/Field	Name	Type	Reset	Description
31:8	reserved	RO	0x0000.000	Software should not rely on the value of a reserved bit. To provide compatibility with future products, the value of a reserved bit should be preserved across a read-modify-write operation.
7	STAT7	RO	0	K[7] Wake Status This is for future use. Value Description 0 Pin is not wake up source 1 Pin wake event asserted to hibernate module
6	STAT6	RO	0	K[6] Wake Status This is for future use. Value Description 0 Pin is not wake up source 1 Pin wake event asserted to hibernate module

Bit/Field	Name	Type	Reset	Description
5	STAT5	RO	0	K[5] Wake Status This is for future use. Value Description 0 Pin is not wake up source 1 Pin wake event asserted to hibernate module
4	STAT4	RO	0	K[4] Wake Status Value Description 0 Pin is not wake up source 1 Pin wake event asserted to hibernate module
3:0	reserved	RO	0	Software should not rely on the value of a reserved bit. To provide compatibility with future products, the value of a reserved bit should be preserved across a read-modify-write operation.

Register 30: GPIO Peripheral Property (GPIOPP), offset 0xFC0

The **GPIOPP** register provides information regarding the GPIO properties.

GPIO Peripheral Property (GPIOPP)

GPIO Port A (AHB) base: 0x4005.8000
 GPIO Port B (AHB) base: 0x4005.9000
 GPIO Port C (AHB) base: 0x4005.A000
 GPIO Port D (AHB) base: 0x4005.B000
 GPIO Port E (AHB) base: 0x4005.C000
 GPIO Port F (AHB) base: 0x4005.D000
 GPIO Port G (AHB) base: 0x4005.E000
 GPIO Port H (AHB) base: 0x4005.F000
 GPIO Port J (AHB) base: 0x4006.0000
 GPIO Port K (AHB) base: 0x4006.1000
 GPIO Port L (AHB) base: 0x4006.2000
 GPIO Port M (AHB) base: 0x4006.3000
 GPIO Port N (AHB) base: 0x4006.4000
 GPIO Port P (AHB) base: 0x4006.5000
 GPIO Port Q (AHB) base: 0x4006.6000

Offset 0xFC0

Type RO, reset 0x0000.0001

	31	30	29	28	27	26	25	24	23	22	21	20	19	18	17	16
	reserved															
Type	RO	RO	RO	RO	RO	RO	RO	RO	RO	RO	RO	RO	RO	RO	RO	RO
Reset	0	0	0	0	0	0	0	0	0	0	0	0	0	0	0	0
	15	14	13	12	11	10	9	8	7	6	5	4	3	2	1	0
	reserved															EDE
Type	RO	RO	RO	RO	RO	RO	RO	RO	RO	RO	RO	RO	RO	RO	RO	RO
Reset	0	0	0	0	0	0	0	0	0	0	0	0	0	0	0	1

Bit/Field	Name	Type	Reset	Description
31:1	reserved	RO	0x0	Software should not rely on the value of a reserved bit. To provide compatibility with future products, the value of a reserved bit should be preserved across a read-modify-write operation.
0	EDE	RO	0x1	Extended Drive Enable This bit specifies whether the extended drive capabilities are provided. Extended drive is configured by the EDM bits in the GPIOPC register.
Value Description				
0	No Extended Drive Capability provided.			
1	Extended Drive Capability provided.			

Register 31: GPIO Peripheral Configuration (GPIOPC), offset 0xFC4

This **GPIOPC** register controls the extended drive modes of the GPIO and must be configured before the **GPIODRnR** registers in order for extended drive mode to take effect. When the **EDE** bit in **GPIOPP** register is set and the **EDM_n** bit field is non-zero, the **GPIODRnR** registers do not drive their default value, but instead output an incremental drive strength, which has an additive effect. This allows for more drive strength possibilities. When the **EDE** bit is set and the **EDM_n** bit field is non-zero, the 2 mA driver is always enabled. Any bits enabled in the **GPIODR4R** register will add an additional 2 mA; any bits set in the **GPIODR8R** add an extra 4 mA of drive. The **GPIODR12R** register is only valid when the **EDM_n** value is 0x3. For this encoding, setting a bit in the **GPIODR12R** register adds 4 mA of drive to the already existing 8 mA, for a 12 mA drive strength. Table 10-3 on page 761 shows the drive capability options. If **EDM_n** is 0x00, then the **GPIODR2R**, **GPIODR4R**, and **GPIODR8R** function as stated in their default register description.

Table 10-13. GPIO Drive Strength Options

EDE (GPIOPP)	EDM _n (GPIOPC)	GPIODR12R (+4mA)	GPIODR8R (+4mA)	GPIODR4R (+2mA)	GPIODR2R (2mA)	Drive (mA)
X	0x0	N/A	0	0	1	2
			0	1	0	4
			1	0	0	8
1	0x1	N/A	0	0	N/A	2
			0	1	N/A	4
			1	0	N/A	6
			1	1	N/A	8
1	0x3	0	0	0	N/A	2
		0	0	1	N/A	4
		0	1	0	N/A	6
		0	1	1	N/A	8
		1	1	0	N/A	10
		1	1	1	N/A	12
		1	0	N/A	N/A	N/A
1	0x2	N/A	N/A	N/A	N/A	N/A

GPIO Peripheral Configuration (GPIOPC)

GPIO Port A (AHB) base: 0x4005.8000
 GPIO Port B (AHB) base: 0x4005.9000
 GPIO Port C (AHB) base: 0x4005.A000
 GPIO Port D (AHB) base: 0x4005.B000
 GPIO Port E (AHB) base: 0x4005.C000
 GPIO Port F (AHB) base: 0x4005.D000
 GPIO Port G (AHB) base: 0x4005.E000
 GPIO Port H (AHB) base: 0x4005.F000
 GPIO Port J (AHB) base: 0x4006.0000
 GPIO Port K (AHB) base: 0x4006.1000
 GPIO Port L (AHB) base: 0x4006.2000
 GPIO Port M (AHB) base: 0x4006.3000
 GPIO Port N (AHB) base: 0x4006.4000
 GPIO Port P (AHB) base: 0x4006.5000
 GPIO Port Q (AHB) base: 0x4006.6000
 Offset 0xFC4
 Type RW, reset 0x0000.0000

	31	30	29	28	27	26	25	24	23	22	21	20	19	18	17	16
	reserved															
Type	RO	RO	RO	RO	RO	RO	RO	RO	RO	RO	RO	RO	RO	RO	RO	RO
Reset	0	0	0	0	0	0	0	0	0	0	0	0	0	0	0	0
	15	14	13	12	11	10	9	8	7	6	5	4	3	2	1	0
	EDM7		EDM6		EDM5		EDM4		EDM3		EDM2		EDM1		EDM0	
Type	RW	RW	RW	RW	RW	RW	RW	RW	RW	RW	RW	RW	RW	RW	RW	RW
Reset	0	0	0	0	0	0	0	0	0	0	0	0	0	0	0	0

Bit/Field	Name	Type	Reset	Description
31:16	reserved	RO	0x0000.000	Software should not rely on the value of a reserved bit. To provide compatibility with future products, the value of a reserved bit should be preserved across a read-modify-write operation.
15:14	EDM7	RW	0	Extended Drive Mode Bit 7 Same encoding as EDM0, but applies to bit 7 of GPIO port.
13:12	EDM6	RW	0	Extended Drive Mode Bit 6 Same encoding as EDM0, but applies to bit 6 of GPIO port.
11:10	EDM5	RW	0	Extended Drive Mode Bit 5 Same encoding as EDM0, but applies to bit 5 of GPIO port.
9:8	EDM4	RW	0	Extended Drive Mode Bit 4 Same encoding as EDM0, but applies to bit 4 of GPIO port.
7:6	EDM3	RW	0	Extended Drive Mode Bit 3 Same encoding as EDM0, but applies to bit 3 of GPIO port.
5:4	EDM2	RW	0	Extended Drive Mode Bit 2 Same encoding as EDM0, but applies to bit 2 of GPIO port.
3:2	EDM1	RW	0	Extended Drive Mode Bit 1 Same encoding as EDM0, but applies to bit 1 of GPIO port.

Bit/Field	Name	Type	Reset	Description
1:0	EDM0	RW	0	<p>Extended Drive Mode Bit 0</p> <p>This field controls extended drive modes of bit 0 of the GPIO port.</p> <p>Note that depending on the encoding used the GPIO drive strength control registers may change their decoding. Moreover, the write one, clear other register behavior may be disabled.</p> <p>Value Description</p> <p>0x0 Drive values of 2, 4 and 8 mA are maintained. GPIO n Drive Select (GPIODRnR) registers function as normal.</p> <p>0x1 An additional 6 mA option is provided. Write one, clear other behavior of GPIODDRnR registers is disabled. A 2 mA driver is always enabled; setting the corresponding GPIODR4R register bit adds 2 mA and setting the corresponding GPIODR8R register bit adds an additional 4 mA.</p> <p>0x2 reserved</p> <p>0x3 Additional drive strength options of 6, 10, and 12 mA are provided. The write one, clear other behavior of GPIODDRnR registers is disabled. A 2 mA driver is always enabled; setting the corresponding GPIODR4R register bit adds 2 mA and setting the corresponding GPIODR8R of GPIODR12R register bit adds an additional 4 mA.</p>

Register 32: GPIO Peripheral Identification 4 (GPIOPeriphID4), offset 0xFD0

The **GPIOPeriphID4**, **GPIOPeriphID5**, **GPIOPeriphID6**, and **GPIOPeriphID7** registers can conceptually be treated as one 32-bit register; each register contains eight bits of the 32-bit register, used by software to identify the peripheral.

GPIO Peripheral Identification 4 (GPIOPeriphID4)

GPIO Port A (AHB) base: 0x4005.8000
 GPIO Port B (AHB) base: 0x4005.9000
 GPIO Port C (AHB) base: 0x4005.A000
 GPIO Port D (AHB) base: 0x4005.B000
 GPIO Port E (AHB) base: 0x4005.C000
 GPIO Port F (AHB) base: 0x4005.D000
 GPIO Port G (AHB) base: 0x4005.E000
 GPIO Port H (AHB) base: 0x4005.F000
 GPIO Port J (AHB) base: 0x4006.0000
 GPIO Port K (AHB) base: 0x4006.1000
 GPIO Port L (AHB) base: 0x4006.2000
 GPIO Port M (AHB) base: 0x4006.3000
 GPIO Port N (AHB) base: 0x4006.4000
 GPIO Port P (AHB) base: 0x4006.5000
 GPIO Port Q (AHB) base: 0x4006.6000
 Offset 0xFD0

Type RO, reset 0x0000.0000

	31	30	29	28	27	26	25	24	23	22	21	20	19	18	17	16
	reserved															
Type	RO	RO	RO	RO	RO	RO	RO	RO	RO	RO	RO	RO	RO	RO	RO	RO
Reset	0	0	0	0	0	0	0	0	0	0	0	0	0	0	0	0
	15	14	13	12	11	10	9	8	7	6	5	4	3	2	1	0
	reserved								PID4							
Type	RO	RO	RO	RO	RO	RO	RO	RO	RO	RO	RO	RO	RO	RO	RO	RO
Reset	0	0	0	0	0	0	0	0	0	0	0	0	0	0	0	0

Bit/Field	Name	Type	Reset	Description
31:8	reserved	RO	0x0000.00	Software should not rely on the value of a reserved bit. To provide compatibility with future products, the value of a reserved bit should be preserved across a read-modify-write operation.
7:0	PID4	RO	0x00	GPIO Peripheral ID Register [7:0]

Register 33: GPIO Peripheral Identification 5 (GPIOPeriphID5), offset 0xFD4

The **GPIOPeriphID4**, **GPIOPeriphID5**, **GPIOPeriphID6**, and **GPIOPeriphID7** registers can conceptually be treated as one 32-bit register; each register contains eight bits of the 32-bit register, used by software to identify the peripheral.

GPIO Peripheral Identification 5 (GPIOPeriphID5)

- GPIO Port A (AHB) base: 0x4005.8000
- GPIO Port B (AHB) base: 0x4005.9000
- GPIO Port C (AHB) base: 0x4005.A000
- GPIO Port D (AHB) base: 0x4005.B000
- GPIO Port E (AHB) base: 0x4005.C000
- GPIO Port F (AHB) base: 0x4005.D000
- GPIO Port G (AHB) base: 0x4005.E000
- GPIO Port H (AHB) base: 0x4005.F000
- GPIO Port J (AHB) base: 0x4006.0000
- GPIO Port K (AHB) base: 0x4006.1000
- GPIO Port L (AHB) base: 0x4006.2000
- GPIO Port M (AHB) base: 0x4006.3000
- GPIO Port N (AHB) base: 0x4006.4000
- GPIO Port P (AHB) base: 0x4006.5000
- GPIO Port Q (AHB) base: 0x4006.6000

Offset 0xFD4
Type RO, reset 0x0000.0000

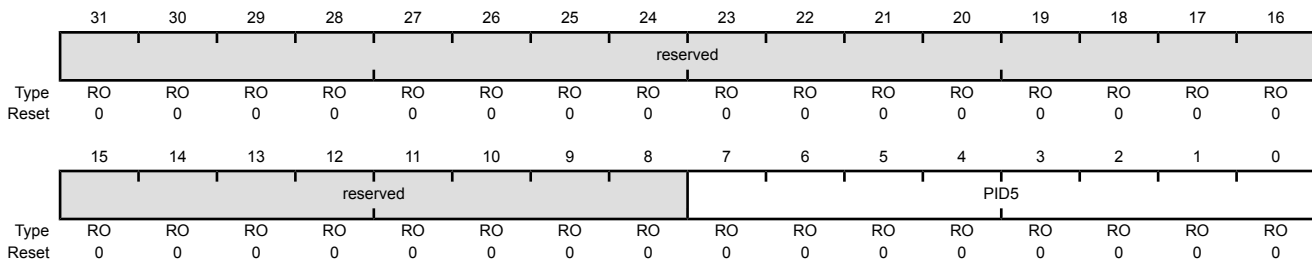

Bit/Field	Name	Type	Reset	Description
31:8	reserved	RO	0x0000.00	Software should not rely on the value of a reserved bit. To provide compatibility with future products, the value of a reserved bit should be preserved across a read-modify-write operation.
7:0	PID5	RO	0x00	GPIO Peripheral ID Register [15:8]

Register 34: GPIO Peripheral Identification 6 (GPIOPeriphID6), offset 0xFD8

The **GPIOPeriphID4**, **GPIOPeriphID5**, **GPIOPeriphID6**, and **GPIOPeriphID7** registers can conceptually be treated as one 32-bit register; each register contains eight bits of the 32-bit register, used by software to identify the peripheral.

GPIO Peripheral Identification 6 (GPIOPeriphID6)

GPIO Port A (AHB) base: 0x4005.8000
 GPIO Port B (AHB) base: 0x4005.9000
 GPIO Port C (AHB) base: 0x4005.A000
 GPIO Port D (AHB) base: 0x4005.B000
 GPIO Port E (AHB) base: 0x4005.C000
 GPIO Port F (AHB) base: 0x4005.D000
 GPIO Port G (AHB) base: 0x4005.E000
 GPIO Port H (AHB) base: 0x4005.F000
 GPIO Port J (AHB) base: 0x4006.0000
 GPIO Port K (AHB) base: 0x4006.1000
 GPIO Port L (AHB) base: 0x4006.2000
 GPIO Port M (AHB) base: 0x4006.3000
 GPIO Port N (AHB) base: 0x4006.4000
 GPIO Port P (AHB) base: 0x4006.5000
 GPIO Port Q (AHB) base: 0x4006.6000
 Offset 0xFD8

Type RO, reset 0x0000.0000

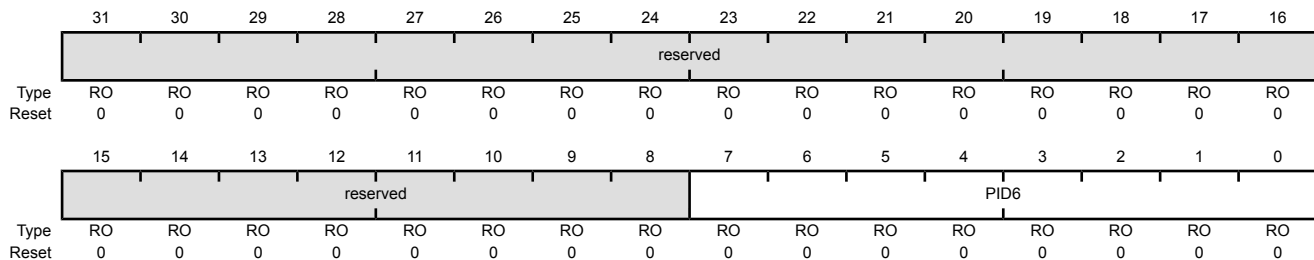

Bit/Field	Name	Type	Reset	Description
31:8	reserved	RO	0x0000.00	Software should not rely on the value of a reserved bit. To provide compatibility with future products, the value of a reserved bit should be preserved across a read-modify-write operation.
7:0	PID6	RO	0x00	GPIO Peripheral ID Register [23:16]

Register 35: GPIO Peripheral Identification 7 (GPIOPeriphID7), offset 0xFDC

The **GPIOPeriphID4**, **GPIOPeriphID5**, **GPIOPeriphID6**, and **GPIOPeriphID7** registers can conceptually be treated as one 32-bit register; each register contains eight bits of the 32-bit register, used by software to identify the peripheral.

GPIO Peripheral Identification 7 (GPIOPeriphID7)

- GPIO Port A (AHB) base: 0x4005.8000
- GPIO Port B (AHB) base: 0x4005.9000
- GPIO Port C (AHB) base: 0x4005.A000
- GPIO Port D (AHB) base: 0x4005.B000
- GPIO Port E (AHB) base: 0x4005.C000
- GPIO Port F (AHB) base: 0x4005.D000
- GPIO Port G (AHB) base: 0x4005.E000
- GPIO Port H (AHB) base: 0x4005.F000
- GPIO Port J (AHB) base: 0x4006.0000
- GPIO Port K (AHB) base: 0x4006.1000
- GPIO Port L (AHB) base: 0x4006.2000
- GPIO Port M (AHB) base: 0x4006.3000
- GPIO Port N (AHB) base: 0x4006.4000
- GPIO Port P (AHB) base: 0x4006.5000
- GPIO Port Q (AHB) base: 0x4006.6000

Offset 0xFDC
Type RO, reset 0x0000.0000

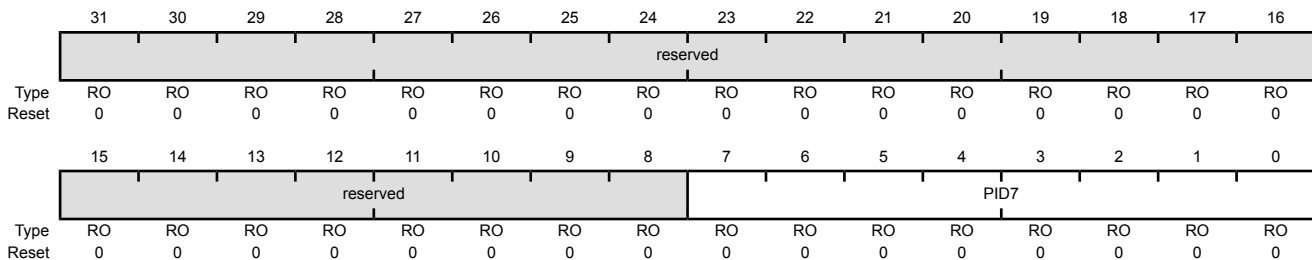

Bit/Field	Name	Type	Reset	Description
31:8	reserved	RO	0x0000.00	Software should not rely on the value of a reserved bit. To provide compatibility with future products, the value of a reserved bit should be preserved across a read-modify-write operation.
7:0	PID7	RO	0x00	GPIO Peripheral ID Register [31:24]

Register 36: GPIO Peripheral Identification 0 (GPIOPeriphID0), offset 0xFE0

The **GPIOPeriphID0**, **GPIOPeriphID1**, **GPIOPeriphID2**, and **GPIOPeriphID3** registers can conceptually be treated as one 32-bit register; each register contains eight bits of the 32-bit register, used by software to identify the peripheral.

GPIO Peripheral Identification 0 (GPIOPeriphID0)

GPIO Port A (AHB) base: 0x4005.8000
 GPIO Port B (AHB) base: 0x4005.9000
 GPIO Port C (AHB) base: 0x4005.A000
 GPIO Port D (AHB) base: 0x4005.B000
 GPIO Port E (AHB) base: 0x4005.C000
 GPIO Port F (AHB) base: 0x4005.D000
 GPIO Port G (AHB) base: 0x4005.E000
 GPIO Port H (AHB) base: 0x4005.F000
 GPIO Port J (AHB) base: 0x4006.0000
 GPIO Port K (AHB) base: 0x4006.1000
 GPIO Port L (AHB) base: 0x4006.2000
 GPIO Port M (AHB) base: 0x4006.3000
 GPIO Port N (AHB) base: 0x4006.4000
 GPIO Port P (AHB) base: 0x4006.5000
 GPIO Port Q (AHB) base: 0x4006.6000
 Offset 0xFE0

Type RO, reset 0x0000.0061

	31	30	29	28	27	26	25	24	23	22	21	20	19	18	17	16
	reserved															
Type	RO	RO	RO	RO	RO	RO	RO	RO	RO	RO	RO	RO	RO	RO	RO	RO
Reset	0	0	0	0	0	0	0	0	0	0	0	0	0	0	0	0
	15	14	13	12	11	10	9	8	7	6	5	4	3	2	1	0
	reserved								PID0							
Type	RO	RO	RO	RO	RO	RO	RO	RO	RO	RO	RO	RO	RO	RO	RO	RO
Reset	0	0	0	0	0	0	0	0	0	1	1	0	0	0	0	1

Bit/Field	Name	Type	Reset	Description
31:8	reserved	RO	0x0000.00	Software should not rely on the value of a reserved bit. To provide compatibility with future products, the value of a reserved bit should be preserved across a read-modify-write operation.
7:0	PID0	RO	0x61	GPIO Peripheral ID Register [7:0] Can be used by software to identify the presence of this peripheral.

Register 37: GPIO Peripheral Identification 1 (GPIOPeriphID1), offset 0xFE4

The **GPIOPeriphID0**, **GPIOPeriphID1**, **GPIOPeriphID2**, and **GPIOPeriphID3** registers can conceptually be treated as one 32-bit register; each register contains eight bits of the 32-bit register, used by software to identify the peripheral.

GPIO Peripheral Identification 1 (GPIOPeriphID1)

GPIO Port A (AHB) base: 0x4005.8000
 GPIO Port B (AHB) base: 0x4005.9000
 GPIO Port C (AHB) base: 0x4005.A000
 GPIO Port D (AHB) base: 0x4005.B000
 GPIO Port E (AHB) base: 0x4005.C000
 GPIO Port F (AHB) base: 0x4005.D000
 GPIO Port G (AHB) base: 0x4005.E000
 GPIO Port H (AHB) base: 0x4005.F000
 GPIO Port J (AHB) base: 0x4006.0000
 GPIO Port K (AHB) base: 0x4006.1000
 GPIO Port L (AHB) base: 0x4006.2000
 GPIO Port M (AHB) base: 0x4006.3000
 GPIO Port N (AHB) base: 0x4006.4000
 GPIO Port P (AHB) base: 0x4006.5000
 GPIO Port Q (AHB) base: 0x4006.6000
 Offset 0xFE4

Type RO, reset 0x0000.0000

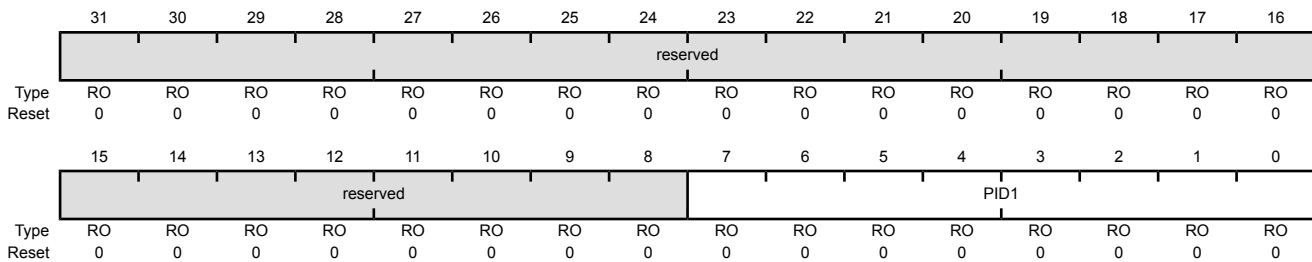

Bit/Field	Name	Type	Reset	Description
31:8	reserved	RO	0x0000.00	Software should not rely on the value of a reserved bit. To provide compatibility with future products, the value of a reserved bit should be preserved across a read-modify-write operation.
7:0	PID1	RO	0x00	GPIO Peripheral ID Register [15:8] Can be used by software to identify the presence of this peripheral.

Register 38: GPIO Peripheral Identification 2 (GPIOPeriphID2), offset 0xFE8

The **GPIOPeriphID0**, **GPIOPeriphID1**, **GPIOPeriphID2**, and **GPIOPeriphID3** registers can conceptually be treated as one 32-bit register; each register contains eight bits of the 32-bit register, used by software to identify the peripheral.

GPIO Peripheral Identification 2 (GPIOPeriphID2)

GPIO Port A (AHB) base: 0x4005.8000
 GPIO Port B (AHB) base: 0x4005.9000
 GPIO Port C (AHB) base: 0x4005.A000
 GPIO Port D (AHB) base: 0x4005.B000
 GPIO Port E (AHB) base: 0x4005.C000
 GPIO Port F (AHB) base: 0x4005.D000
 GPIO Port G (AHB) base: 0x4005.E000
 GPIO Port H (AHB) base: 0x4005.F000
 GPIO Port J (AHB) base: 0x4006.0000
 GPIO Port K (AHB) base: 0x4006.1000
 GPIO Port L (AHB) base: 0x4006.2000
 GPIO Port M (AHB) base: 0x4006.3000
 GPIO Port N (AHB) base: 0x4006.4000
 GPIO Port P (AHB) base: 0x4006.5000
 GPIO Port Q (AHB) base: 0x4006.6000
 Offset 0xFE8

Type RO, reset 0x0000.0018

	31	30	29	28	27	26	25	24	23	22	21	20	19	18	17	16
	reserved															
Type	RO	RO	RO	RO	RO	RO	RO	RO	RO	RO	RO	RO	RO	RO	RO	RO
Reset	0	0	0	0	0	0	0	0	0	0	0	0	0	0	0	0
	15	14	13	12	11	10	9	8	7	6	5	4	3	2	1	0
	reserved								PID2							
Type	RO	RO	RO	RO	RO	RO	RO	RO	RO	RO	RO	RO	RO	RO	RO	RO
Reset	0	0	0	0	0	0	0	0	0	0	0	0	1	1	0	0

Bit/Field	Name	Type	Reset	Description
31:8	reserved	RO	0x0000.00	Software should not rely on the value of a reserved bit. To provide compatibility with future products, the value of a reserved bit should be preserved across a read-modify-write operation.
7:0	PID2	RO	0x18	GPIO Peripheral ID Register [23:16] Can be used by software to identify the presence of this peripheral.

Register 39: GPIO Peripheral Identification 3 (GPIOPeriphID3), offset 0xFEC

The **GPIOPeriphID0**, **GPIOPeriphID1**, **GPIOPeriphID2**, and **GPIOPeriphID3** registers can conceptually be treated as one 32-bit register; each register contains eight bits of the 32-bit register, used by software to identify the peripheral.

GPIO Peripheral Identification 3 (GPIOPeriphID3)

GPIO Port A (AHB) base: 0x4005.8000
 GPIO Port B (AHB) base: 0x4005.9000
 GPIO Port C (AHB) base: 0x4005.A000
 GPIO Port D (AHB) base: 0x4005.B000
 GPIO Port E (AHB) base: 0x4005.C000
 GPIO Port F (AHB) base: 0x4005.D000
 GPIO Port G (AHB) base: 0x4005.E000
 GPIO Port H (AHB) base: 0x4005.F000
 GPIO Port J (AHB) base: 0x4006.0000
 GPIO Port K (AHB) base: 0x4006.1000
 GPIO Port L (AHB) base: 0x4006.2000
 GPIO Port M (AHB) base: 0x4006.3000
 GPIO Port N (AHB) base: 0x4006.4000
 GPIO Port P (AHB) base: 0x4006.5000
 GPIO Port Q (AHB) base: 0x4006.6000
 Offset 0xFEC

Type RO, reset 0x0000.0001

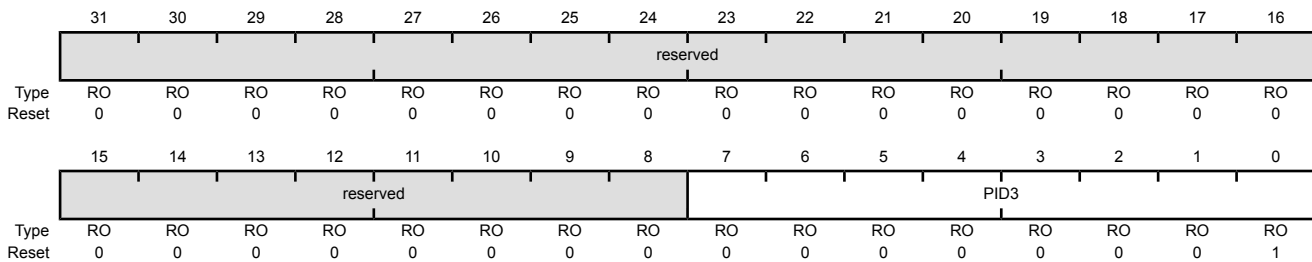

Bit/Field	Name	Type	Reset	Description
31:8	reserved	RO	0x0000.00	Software should not rely on the value of a reserved bit. To provide compatibility with future products, the value of a reserved bit should be preserved across a read-modify-write operation.
7:0	PID3	RO	0x01	GPIO Peripheral ID Register [31:24] Can be used by software to identify the presence of this peripheral.

Register 40: GPIO PrimeCell Identification 0 (GPIOCellID0), offset 0xFF0

The **GPIOCellID0**, **GPIOCellID1**, **GPIOCellID2**, and **GPIOCellID3** registers are four 8-bit wide registers, that can conceptually be treated as one 32-bit register. The register is used as a standard cross-peripheral identification system.

GPIO PrimeCell Identification 0 (GPIOCellID0)

GPIO Port A (AHB) base: 0x4005.8000
 GPIO Port B (AHB) base: 0x4005.9000
 GPIO Port C (AHB) base: 0x4005.A000
 GPIO Port D (AHB) base: 0x4005.B000
 GPIO Port E (AHB) base: 0x4005.C000
 GPIO Port F (AHB) base: 0x4005.D000
 GPIO Port G (AHB) base: 0x4005.E000
 GPIO Port H (AHB) base: 0x4005.F000
 GPIO Port J (AHB) base: 0x4006.0000
 GPIO Port K (AHB) base: 0x4006.1000
 GPIO Port L (AHB) base: 0x4006.2000
 GPIO Port M (AHB) base: 0x4006.3000
 GPIO Port N (AHB) base: 0x4006.4000
 GPIO Port P (AHB) base: 0x4006.5000
 GPIO Port Q (AHB) base: 0x4006.6000
 Offset 0xFF0

Type RO, reset 0x0000.000D

	31	30	29	28	27	26	25	24	23	22	21	20	19	18	17	16
	reserved															
Type	RO	RO	RO	RO	RO	RO	RO	RO	RO	RO	RO	RO	RO	RO	RO	RO
Reset	0	0	0	0	0	0	0	0	0	0	0	0	0	0	0	0
	15	14	13	12	11	10	9	8	7	6	5	4	3	2	1	0
	reserved								CID0							
Type	RO	RO	RO	RO	RO	RO	RO	RO	RO	RO	RO	RO	RO	RO	RO	RO
Reset	0	0	0	0	0	0	0	0	0	0	0	0	1	1	0	1

Bit/Field	Name	Type	Reset	Description
31:8	reserved	RO	0x0000.00	Software should not rely on the value of a reserved bit. To provide compatibility with future products, the value of a reserved bit should be preserved across a read-modify-write operation.
7:0	CID0	RO	0x0D	GPIO PrimeCell ID Register [7:0] Provides software a standard cross-peripheral identification system.

Register 41: GPIO PrimeCell Identification 1 (GPIOCellID1), offset 0xFF4

The **GPIOCellID0**, **GPIOCellID1**, **GPIOCellID2**, and **GPIOCellID3** registers are four 8-bit wide registers, that can conceptually be treated as one 32-bit register. The register is used as a standard cross-peripheral identification system.

GPIO PrimeCell Identification 1 (GPIOCellID1)

GPIO Port A (AHB) base: 0x4005.8000
 GPIO Port B (AHB) base: 0x4005.9000
 GPIO Port C (AHB) base: 0x4005.A000
 GPIO Port D (AHB) base: 0x4005.B000
 GPIO Port E (AHB) base: 0x4005.C000
 GPIO Port F (AHB) base: 0x4005.D000
 GPIO Port G (AHB) base: 0x4005.E000
 GPIO Port H (AHB) base: 0x4005.F000
 GPIO Port J (AHB) base: 0x4006.0000
 GPIO Port K (AHB) base: 0x4006.1000
 GPIO Port L (AHB) base: 0x4006.2000
 GPIO Port M (AHB) base: 0x4006.3000
 GPIO Port N (AHB) base: 0x4006.4000
 GPIO Port P (AHB) base: 0x4006.5000
 GPIO Port Q (AHB) base: 0x4006.6000
 Offset 0xFF4

Type RO, reset 0x0000.00F0

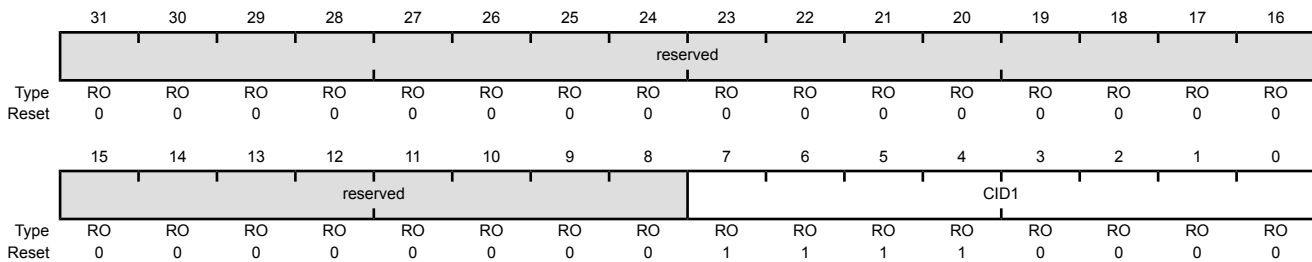

Bit/Field	Name	Type	Reset	Description
31:8	reserved	RO	0x0000.00	Software should not rely on the value of a reserved bit. To provide compatibility with future products, the value of a reserved bit should be preserved across a read-modify-write operation.
7:0	CID1	RO	0xF0	GPIO PrimeCell ID Register [15:8] Provides software a standard cross-peripheral identification system.

Register 42: GPIO PrimeCell Identification 2 (GPIOCellID2), offset 0xFF8

The **GPIOCellID0**, **GPIOCellID1**, **GPIOCellID2**, and **GPIOCellID3** registers are four 8-bit wide registers, that can conceptually be treated as one 32-bit register. The register is used as a standard cross-peripheral identification system.

GPIO PrimeCell Identification 2 (GPIOCellID2)

GPIO Port A (AHB) base: 0x4005.8000
 GPIO Port B (AHB) base: 0x4005.9000
 GPIO Port C (AHB) base: 0x4005.A000
 GPIO Port D (AHB) base: 0x4005.B000
 GPIO Port E (AHB) base: 0x4005.C000
 GPIO Port F (AHB) base: 0x4005.D000
 GPIO Port G (AHB) base: 0x4005.E000
 GPIO Port H (AHB) base: 0x4005.F000
 GPIO Port J (AHB) base: 0x4006.0000
 GPIO Port K (AHB) base: 0x4006.1000
 GPIO Port L (AHB) base: 0x4006.2000
 GPIO Port M (AHB) base: 0x4006.3000
 GPIO Port N (AHB) base: 0x4006.4000
 GPIO Port P (AHB) base: 0x4006.5000
 GPIO Port Q (AHB) base: 0x4006.6000
 Offset 0xFF8

Type RO, reset 0x0000.0005

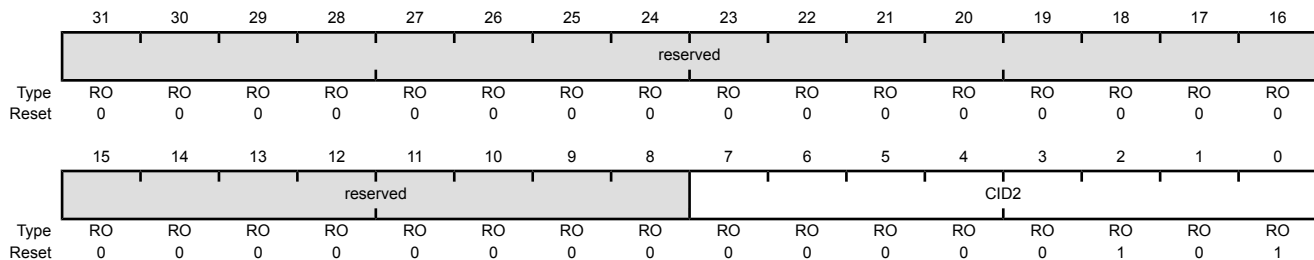

Bit/Field	Name	Type	Reset	Description
31:8	reserved	RO	0x0000.00	Software should not rely on the value of a reserved bit. To provide compatibility with future products, the value of a reserved bit should be preserved across a read-modify-write operation.
7:0	CID2	RO	0x05	GPIO PrimeCell ID Register [23:16] Provides software a standard cross-peripheral identification system.

Register 43: GPIO PrimeCell Identification 3 (GPIOCellID3), offset 0xFFC

The **GPIOCellID0**, **GPIOCellID1**, **GPIOCellID2**, and **GPIOCellID3** registers are four 8-bit wide registers, that can conceptually be treated as one 32-bit register. The register is used as a standard cross-peripheral identification system.

GPIO PrimeCell Identification 3 (GPIOCellID3)

GPIO Port A (AHB) base: 0x4005.8000
 GPIO Port B (AHB) base: 0x4005.9000
 GPIO Port C (AHB) base: 0x4005.A000
 GPIO Port D (AHB) base: 0x4005.B000
 GPIO Port E (AHB) base: 0x4005.C000
 GPIO Port F (AHB) base: 0x4005.D000
 GPIO Port G (AHB) base: 0x4005.E000
 GPIO Port H (AHB) base: 0x4005.F000
 GPIO Port J (AHB) base: 0x4006.0000
 GPIO Port K (AHB) base: 0x4006.1000
 GPIO Port L (AHB) base: 0x4006.2000
 GPIO Port M (AHB) base: 0x4006.3000
 GPIO Port N (AHB) base: 0x4006.4000
 GPIO Port P (AHB) base: 0x4006.5000
 GPIO Port Q (AHB) base: 0x4006.6000

Offset 0xFFC
 Type RO, reset 0x0000.00B1

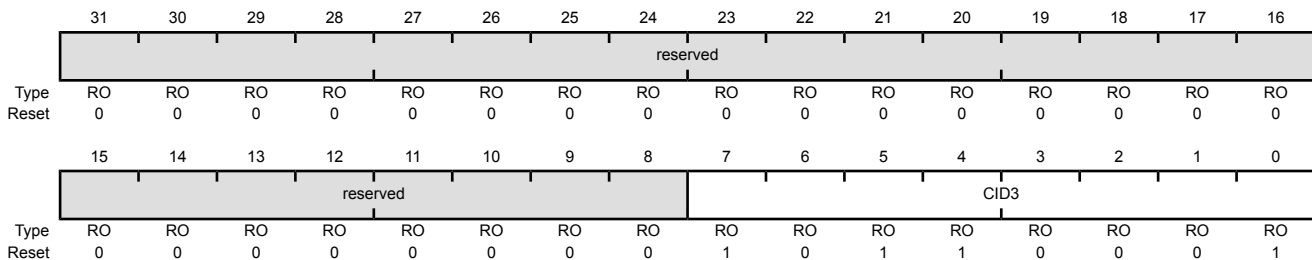

Bit/Field	Name	Type	Reset	Description
31:8	reserved	RO	0x0000.00	Software should not rely on the value of a reserved bit. To provide compatibility with future products, the value of a reserved bit should be preserved across a read-modify-write operation.
7:0	CID3	RO	0xB1	GPIO PrimeCell ID Register [31:24] Provides software a standard cross-peripheral identification system.

11 External Peripheral Interface (EPI)

The External Peripheral Interface is a high-speed parallel bus for external peripherals or memory. It has several modes of operation to interface gluelessly to many types of external devices. The External Peripheral Interface is similar to a standard microprocessor address/data bus, except that it must typically be connected to just one type of external device. Enhanced capabilities include μ DMA support, clocking control and support for external FIFO buffers.

The EPI has the following features:

- 8/16/32-bit dedicated parallel bus for external peripherals and memory
- Memory interface supports contiguous memory access independent of data bus width, thus enabling code execution directly from SDRAM, SRAM and Flash memory
- Blocking and non-blocking reads
- Separates processor from timing details through use of an internal write FIFO
- Efficient transfers using Micro Direct Memory Access Controller (μ DMA)
 - Separate channels for read and write
 - Read channel request asserted by programmable levels on the internal Non-Blocking Read FIFO (NBRFIFO)
 - Write channel request asserted by empty on the internal Write FIFO (WFIFO)

The EPI supports three primary functional modes: Synchronous Dynamic Random Access Memory (SDRAM) mode, Traditional Host-Bus mode, and General-Purpose mode. The EPI module also provides custom GPIOs; however, unlike regular GPIOs, the EPI module uses a FIFO in the same way as a communication mechanism and is speed-controlled using clocking.

- Synchronous Dynamic Random Access Memory (SDRAM) mode
 - Supports x16 (single data rate) SDRAM at up to 60 MHz
 - Supports low-cost SDRAMs up to 64 MB (512 megabits)
 - Includes automatic refresh and access to all banks/rows
 - Includes a Sleep/Standby mode to keep contents active with minimal power draw
 - Multiplexed address/data interface for reduced pin count
- Host-Bus mode
 - Traditional x8 and x16 MCU bus interface capabilities
 - Similar device compatibility options as PIC, ATmega, 8051, and others
 - Access to SRAM, NOR Flash memory, and other devices, with up to 1 MB of addressing in non-multiplexed mode and 256 MB in multiplexed mode (512 MB in Host-Bus 16 mode with no byte selects)

- Support for up to 512 Mb PSRAM in quad chip select mode, with dedicated configuration register read and write enable.
- Support of both muxed and de-muxed address and data
- Access to a range of devices supporting the non-address FIFO x8 and x16 interface variant, with support for external FIFO (XFIFO) EMPTY and FULL signals
- Speed controlled, with read and write data wait-state counters
- Support for read/write burst mode to Host Bus
- Multiple chip select modes including single, dual, and quad chip selects, with and without ALE
- External iRDY signal provided for stall capability of reads and writes
- Manual chip-enable (or use extra address pins)
- General-Purpose mode
 - Wide parallel interfaces for fast communications with CPLDs and FPGAs
 - Data widths up to 32 bits
 - Data rates up to 150 MB/second
 - Optional "address" sizes from 4 bits to 20 bits
 - Optional clock output, read/write strobes, framing (with counter-based size), and clock-enable input
- General parallel GPIO
 - 1 to 32 bits, FIFOed with speed control
 - Useful for custom peripherals or for digital data acquisition and actuator controls

11.1 EPI Block Diagram

Figure 11-1 on page 825 provides a block diagram of a TM4C129ENCPDT EPI module.

Figure 11-1. EPI Block Diagram

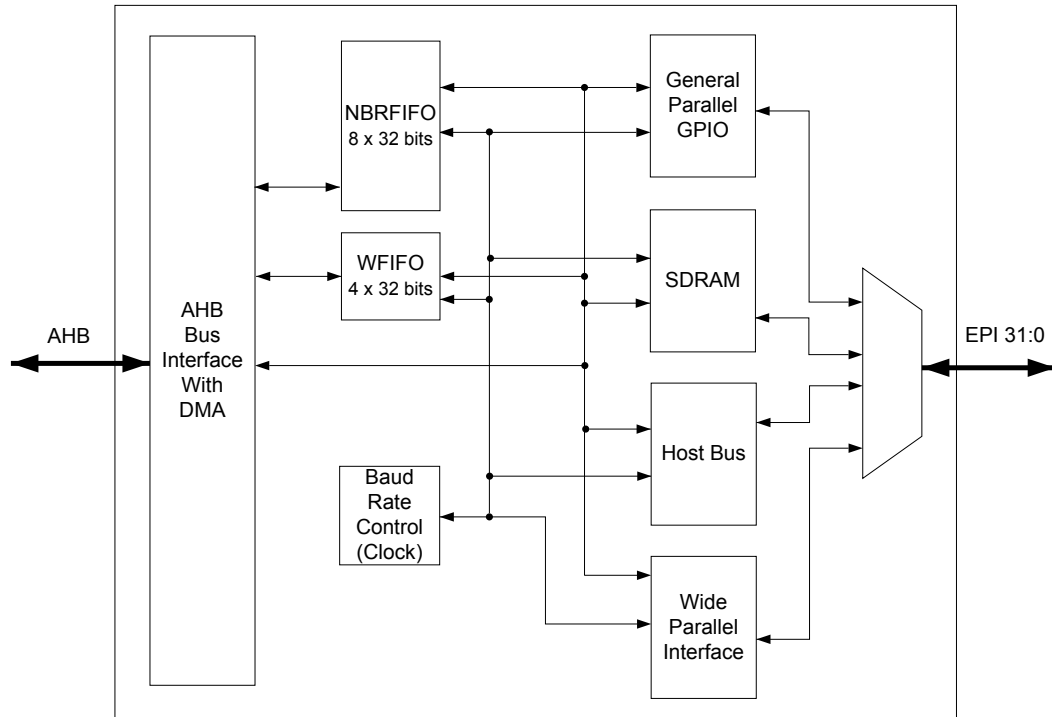

11.2 Signal Description

The following table lists the external signals of the EPI controller and describes the function of each. The EPI controller signals are alternate functions for GPIO signals and default to be GPIO signals at reset. The column in the table below titled "Pin Mux/Pin Assignment" lists the GPIO pin placement for the EPI signals. The `AFSEL` bit in the **GPIO Alternate Function Select (GPIOAFSEL)** register (page 778) should be set to choose the EPI controller function. The number in parentheses is the encoding that must be programmed into the `PMCn` field in the **GPIO Port Control (GPIOPTL)** register (page 795) to assign the EPI signals to the specified GPIO port pins. For more information on configuring GPIOs, see "General-Purpose Input/Outputs (GPIOs)" on page 750.

Table 11-1. External Peripheral Interface Signals (128TQFP)

Pin Name	Pin Number	Pin Mux / Pin Assignment	Pin Type	Buffer Type	Description
EPI0S0	18 29	PK0 (15) PH0 (15)	I/O	TTL	EPI module 0 signal 0.
EPI0S1	19 30	PK1 (15) PH1 (15)	I/O	TTL	EPI module 0 signal 1.
EPI0S2	20 31	PK2 (15) PH2 (15)	I/O	TTL	EPI module 0 signal 2.
EPI0S3	21 32	PK3 (15) PH3 (15)	I/O	TTL	EPI module 0 signal 3.
EPI0S4	22	PC7 (15)	I/O	TTL	EPI module 0 signal 4.
EPI0S5	23	PC6 (15)	I/O	TTL	EPI module 0 signal 5.
EPI0S6	24	PC5 (15)	I/O	TTL	EPI module 0 signal 6.
EPI0S7	25	PC4 (15)	I/O	TTL	EPI module 0 signal 7.

Table 11-1. External Peripheral Interface Signals (128TQFP) (continued)

Pin Name	Pin Number	Pin Mux / Pin Assignment	Pin Type	Buffer Type	Description
EPI0S8	40	PA6 (15)	I/O	TTL	EPI module 0 signal 8.
EPI0S9	41	PA7 (15)	I/O	TTL	EPI module 0 signal 9.
EPI0S10	50	PG1 (15)	I/O	TTL	EPI module 0 signal 10.
EPI0S11	49	PG0 (15)	I/O	TTL	EPI module 0 signal 11.
EPI0S12	75	PM3 (15)	I/O	TTL	EPI module 0 signal 12.
EPI0S13	76	PM2 (15)	I/O	TTL	EPI module 0 signal 13.
EPI0S14	77	PM1 (15)	I/O	TTL	EPI module 0 signal 14.
EPI0S15	78	PM0 (15)	I/O	TTL	EPI module 0 signal 15.
EPI0S16	81	PL0 (15)	I/O	TTL	EPI module 0 signal 16.
EPI0S17	82	PL1 (15)	I/O	TTL	EPI module 0 signal 17.
EPI0S18	83	PL2 (15)	I/O	TTL	EPI module 0 signal 18.
EPI0S19	84	PL3 (15)	I/O	TTL	EPI module 0 signal 19.
EPI0S20	5	PQ0 (15)	I/O	TTL	EPI module 0 signal 20.
EPI0S21	6	PQ1 (15)	I/O	TTL	EPI module 0 signal 21.
EPI0S22	11	PQ2 (15)	I/O	TTL	EPI module 0 signal 22.
EPI0S23	27	PQ3 (15)	I/O	TTL	EPI module 0 signal 23.
EPI0S24	60	PK7 (15)	I/O	TTL	EPI module 0 signal 24.
EPI0S25	61	PK6 (15)	I/O	TTL	EPI module 0 signal 25.
EPI0S26	85	PL4 (15)	I/O	TTL	EPI module 0 signal 26.
EPI0S27	91	PB2 (15)	I/O	TTL	EPI module 0 signal 27.
EPI0S28	92	PB3 (15)	I/O	TTL	EPI module 0 signal 28.
EPI0S29	103 109	PP2 (15) PN2 (15)	I/O	TTL	EPI module 0 signal 29.
EPI0S30	104 110	PP3 (15) PN3 (15)	I/O	TTL	EPI module 0 signal 30.
EPI0S31	62	PK5 (15)	I/O	TTL	EPI module 0 signal 31.
EPI0S32	63	PK4 (15)	I/O	TTL	EPI module 0 signal 32.
EPI0S33	86	PL5 (15)	I/O	TTL	EPI module 0 signal 33.
EPI0S34	111	PN4 (15)	I/O	TTL	EPI module 0 signal 34.
EPI0S35	112	PN5 (15)	I/O	TTL	EPI module 0 signal 35.

11.3 Functional Description

The EPI controller provides a glueless, programmable interface to a variety of common external peripherals such as SDRAM x 16, Host Bus x8 and x16 devices, RAM, NOR Flash memory, CPLDs and FPGAs. In addition, the EPI controller provides custom GPIO that can use a FIFO with speed control by using either the internal write FIFO (WFIFO) or the non-blocking read FIFO (NBRFIFO). The WFIFO can hold 4 words of data that are written to the external interface at the rate controlled by the **EPI Main Baud Rate (EPIBAUD)** registers. The NBRFIFO can hold 8 words of data and samples at the rate controlled by the **EPIBAUD** register. The EPI controller provides predictable operation and thus has an advantage over regular GPIO which has more variable timing due to on-chip bus arbitration and delays across bus bridges. Blocking reads stall the CPU until the transaction completes. Non-blocking reads are performed in the background and allow the processor

to continue operation. In addition, write data can also be stored in the WFIFO to allow multiple writes with no stalls.

Note: Both the `WTAV` bit field in the `EPIWFIFOCNT` register and the `WBUSY` bit in the `EPISTAT` register must be polled to determine if there is a current write transaction from the WFIFO. If both of these bits are clear, then a new bus access may begin.

Main read and write operations can be performed in subsets of the range `0x6000.0000` to `0xDFFF.FFFF`. A read from an address mapped location uses the offset and size to control the address and size of the external operation. When performing a multi-value load, the read is done as a burst (when available) to maximize performance. A write to an address mapped location uses the offset and size to control the address and size of the external operation. When performing a multi-value store, the write is done as a burst (when available) to maximize performance.

11.3.1 Master Access to EPI

The following lists the Bus Masters which have access to the EPI:

- CPU
- μ DMA

11.3.2 Non-Blocking Reads

The EPI Controller supports a special kind of read called a non-blocking read, also referred to as a posted read. Where a normal read stalls the processor or μ DMA until the data is returned, a non-blocking read is performed in the background.

A non-blocking read is configured by writing the start address into a `EPIRADDRn` register, the size per transaction into a `EPIRSIZEn` register, and then the count of operations into a `EPIRPSTDn` register. After each read is completed, the result is written into the NBRFIFO and the `EPIRADDRn` register is incremented by the size (1, 2, or 4). The three most significant bits of `EPIRADDRn` register are only relevant in the Host Bus multi-chip select mode when they are used to enable the different chip selects.

If the NBRFIFO is filled, then the reads pause until space is made available. The NBRFIFO can be configured to interrupt the processor or trigger the μ DMA based on fullness using the `EPIFIFOLVL` register. By using the trigger/interrupt method, the μ DMA (or processor) can keep space available in the NBRFIFO and allow the reads to continue unimpeded.

When performing non-blocking reads, the SDRAM controller issues two additional read transactions after the burst request is terminated. The data for these additional transfers is discarded. This situation is transparent to the user other than the additional EPI bus activity and can safely be ignored.

Two non-blocking read register sets are available to allow sequencing and ping-pong use. When one completes, the other then activates. So, for example, if 20 words are to be read from `0x100` and 10 words from `0x200`, the `EPIRPSTD0` register can be set up with the read from `0x100` (with a count of 20), and the `EPIRPSTD1` register can be set up with the read from `0x200` (with a count of 10). When `EPIRPSTD0` finishes (count goes to 0), the `EPIRPSTD1` register then starts its operation. The NBRFIFO has then passed 30 values. When used with the μ DMA, it may transfer 30 values (simple sequence), or the primary/alternate model may be used to handle the first 20 in one way and the second 10 in another. It is also possible to reload the `EPIRPSTD0` register when it is finished (and the `EPIRPSTD1` register is active); thereby, keeping the interface constantly busy.

To cancel a non-blocking read, the `EPIRPSTDn` register is cleared. Care must be taken, however if the register set was active to drain away any values read into the NBRFIFO and ensure that any read in progress is allowed to complete.

To ensure that the cancel is complete, the following algorithm is used (using the **EPIRPSTD0** register for example):

```
EPIRPSTD0 = 0;
while ((EPISTAT & 0x11) == 0x10)
; // we are active and busy
// if here, then other one is active or interface no longer busy
cnt = (EPIRADDR0 – original_address) / EPIRSIZE0; // count of values read
cnt -= values_read_so_far;
// cnt is now number left in FIFO
while (cnt--)
value = EPIREADFIFO; // drain
```

The above algorithm can be optimized in code; however, the important point is to wait for the cancel to complete because the external interface could have been in the process of reading a value when the cancel came in, and it must be allowed to complete.

11.3.3 DMA Operation

The μ DMA can be used to achieve maximum transfer rates on the EPI through the NBRFIFO and the WRFIFO. The μ DMA has one channel for write and one for read. For writes, the **EPI DMA Transmit Count (EPIDMATXCNT)** register is programmed with the total number of transfers by the μ DMA. An equivalent value is programmed into the **DMA Channel Control Word (DMACHCTL)** register of the μ DMA at offset 0x008. A μ DMA request is asserted by the EPI WRFIFO when the **TXCNT** value of the **EPIDMATXCNT** register is greater than zero and the **WTAV** bit field of the **EPIWFIFOCNT** register is less than the programmed threshold trigger, **WRFIFO**, of the **EPIFIFOLVL** register. The write channel continues to write data until the **TXCNT** value in the **EPIDMATXCNT** register is zero.

Note: When the **WRFIFO** bit in the **EPIFIFOLVL** register is set to 0x4 and the application bursts four words to an empty FIFO, the WRFIFO trigger may or may not deassert depending on if all four words were written to the WRFIFO or if the first word was passed immediately to the function requiring it. Thus, the application may not see the **WRRIS** bit in the **EPIRIS** register clear on a burst of four words.

The non-blocking read channel copies values from the NBRFIFO when the NBRFIFO is at the level specified by the **EPIFIFOLVL** register. For non-blocking reads, the start address, the size per transaction, and the count of elements must be programmed in the μ DMA. Note that both non-blocking read register sets can be used, and they fill the NBRFIFO such that one runs to completion, then the next one starts (they do not interleave). Using the NBRFIFO provides the best possible transfer rate.

For blocking reads, the μ DMA software channel (or another unused channel) is used for memory-to-memory transfers (or memory to peripheral, where some other peripheral is used). In this situation, the μ DMA stalls until the read is complete and is not able to service another channel until the read is done. As a result, the arbitration size should normally be programmed to one access at a time. The μ DMA controller can also transfer from and to the NBRFIFO and the WRFIFO using the μ DMA software channel in memory mode, however, the μ DMA is stalled once the NBRFIFO is empty or the WRFIFO is full. Note that when the μ DMA controller is stalled, the core continues operation. See “Micro Direct Memory Access (μ DMA)” on page 686 for more information on configuring the μ DMA.

The size of the FIFOs must be taken into consideration when configuring the μ DMA to transfer data to and from the EPI. The arbitration size should be 4 or less when writing to EPI address space and 8 or less when reading from EPI address space.

11.4 Initialization and Configuration

To enable and initialize the EPI controller, the following steps are necessary:

1. Enable the EPI module using the **RCGCEPI** register. See page 393.
2. Enable the clock to the appropriate GPIO module via the **RCGCGPIO** register. See page 389. To find out which GPIO port to enable, refer to “Signal Description” on page 825.
3. Set the GPIO **AFSEL** bits for the appropriate pins. See page 778. To determine which GPIOs to configure, see Table 29-4 on page 1921.
4. Configure the GPIO current level and/or slew rate as specified for the mode selected. See page 780 and page 788.
5. Configure the **PMC_n** fields in the **GPIOPCTL** register to assign the EPI signals to the appropriate pins. See page 795 and Table 29-5 on page 1932.
6. Select the mode for the EPI block to SDRAM, HB8, HB16, or general parallel use, using the **MODE** field in the **EPI Configuration (EPICFG)** register. Set the mode-specific details (if needed) using the appropriate mode configuration **EPI Host Bus Configuration (EPIHBnCFGn)** registers for the desired chip-select configuration. Set the **EPI Main Baud Rate (EPIBAUD)** and **EPI Main Baud Rate 2 (EPIBAUD2)** register if the baud rate must be slower than the system clock rate.
7. Configure the address mapping using the **EPI Address Map (EPIADDRMAP)** register. The selected start address and range is dependent on the type of external device and maximum address (as appropriate). For example, for a 512-megabit SDRAM, program the **ERADR** field to 0x1 for address 0x6000.0000 or 0x2 for address 0x8000.0000; and program the **ERSZ** field to 0x3 for 256 MB. If using General-Purpose mode and no address at all, program the **EPADR** field to 0x1 for address 0xA000.0000 or 0x2 for address 0xC000.0000; and program the **EPSZ** field to 0x0 for 256 bytes.
8. To read or write directly, use the mapped address area (configured with the **EPIADDRMAP** register). Up to 4 or 5 writes can be performed at once without blocking. Each read is blocked until the value is retrieved.
9. To perform a non-blocking read, see “Non-Blocking Reads” on page 827.

Note: The application should not attempt to access externally until eight system clock cycles after the EPI has been fully configured.

Note: Once a **MODE** field has been programmed in the **EPICFG** register, the application should reset all configuration registers before re-programming to a new **MODE** value.

The following sub-sections describe the initialization and configuration for each of the modes of operation. Care must be taken to initialize everything properly to ensure correct operation. Control of the GPIO states is also important, as changes may cause the external device to interpret pin states as actions or commands (see “Register Descriptions” on page 766). Normally, a pull-up or pull-down is needed on the board to at least control the chip-select or chip-enable as the TM4C129ENCPDT GPIOs come out of reset in tri-state.

11.4.1 EPI Interface Options

There are a variety of memories and peripherals that can interface to the EPI module. Table 11-2 on page 830 shows the various configurations with their maximum performance.

Table 11-2. EPI Interface Options

Interface	Maximum Frequency
Single SDRAM	60 MHz
Single SRAM	60 MHz
Single PSRAM without iRDY signal use	55 MHz
Single PSRAM with iRDY signal use	52 MHz
FPGAs, CPLDs, etc using General Purpose Mode	60 MHz
Memory configurations with 2 chip selects	40 MHz
Memory configurations with 4 chip selects	20 MHz

11.4.2 SDRAM Mode

When activating the SDRAM mode, it is important to consider a few points:

1. Generally, it takes over 100 μ s from when the mode is activated to when the first operation is allowed. The SDRAM controller begins the SDRAM initialization sequence as soon as the mode is selected and enabled via the **EPICFG** register. It is important that the GPIOs are properly configured before the SDRAM mode is enabled, as the EPI controller is relying on the GPIO block's ability to drive the pins immediately. As part of the initialization sequence, the LOAD MODE REGISTER command is automatically sent to the SDRAM with a value of 0x27, which sets a CAS latency of 2 and a full page burst length.
2. The **INITSEQ** bit in the **EPI Status (EPISTAT)** register can be checked to determine when the initialization sequence is complete.
3. When using a frequency range and/or refresh value other than the default value, it is important to configure the **FREQ** and **RFSH** fields in the **EPI SDRAM Configuration (EPISDRAMCFG)** register shortly after activating the mode. After the 100- μ s startup time, the EPI block must be configured properly to keep the SDRAM contents stable.
4. The **SLEEP** bit in the **EPISDRAMCFG** register may be configured to put the SDRAM into a low-power self-refreshing state. It is important to note that the SDRAM mode must not be disabled once enabled, or else the SDRAM is no longer clocked and the contents are lost.
5. Before entering SLEEP mode, make sure all non-blocking reads and normal reads and writes have completed. If the system is running at 30 to 50 MHz, wait 2 EPI clocks after clearing the **SLEEP** bit before executing non-blocking reads, or normal reads and writes. If the system is configured to greater than 50 MHz, wait 5 EPI clocks before read and write transactions. For all other configurations, wait 1 EPI clock.

The **SIZE** field of the **EPISDRAMCFG** register must be configured correctly based on the amount of SDRAM in the system.

The **FREQ** field must be configured according to the value that represents the range being used. Based on the range selected, the number of external clocks used between certain operations (for example, PRECHARGE or ACTIVATE) is determined. If a higher frequency is given than is used, then the only downside is that the peripheral is slower (uses more cycles for these delays). If a lower frequency is given, incorrect operation occurs.

See “External Peripheral Interface (EPI)” on page 1977 for timing details for the SDRAM mode.

11.4.2.1 External Signal Connections

Table 11-3 on page 831 defines how EPI module signals should be connected to SDRAMs. The table applies when using a x16 SDRAM up to 512 megabits. Note that the EPI signals must use 8-mA drive when interfacing to SDRAM, see page 782. Any unused EPI controller signals can be used as GPIOs or another alternate function.

Table 11-3. EPI SDRAM x16 Signal Connections

EPI Signal	SDRAM Signal ^a	
EPI0S0	A0	D0
EPI0S1	A1	D1
EPI0S2	A2	D2
EPI0S3	A3	D3
EPI0S4	A4	D4
EPI0S5	A5	D5
EPI0S6	A6	D6
EPI0S7	A7	D7
EPI0S8	A8	D8
EPI0S9	A9	D9
EPI0S10	A10	D10
EPI0S11	A11	D11
EPI0S12	A12 ^b	D12
EPI0S13	BA0	D13
EPI0S14	BA1	D14
EPI0S15	D15	
EPI0S16	DQML	
EPI0S17	DQMH	
EPI0S18	CASn	
EPI0S19	RASn	
EPI0S20-EPI0S27	not used	
EPI0S28	WEn	
EPI0S29	CSn	
EPI0S30	CKE	
EPI0S31	CLK	

a. If two signals are listed, connect the EPI signal to both pins.

b. Only for 256/512 megabit SDRAMs.

11.4.2.2 Refresh Configuration

The refresh count is based on the external clock speed and the number of rows per bank as well as the refresh period. The `RFSH` field represents how many external clock cycles remain before an AUTO-REFRESH is required. The normal formula is:

$$RFSH = (t_{Refresh_us} / number_rows) / ext_clock_period$$

A refresh period is normally 64 ms, or 64000 μ s. The number of rows is normally 4096 or 8192. The `ext_clock_period` is a value expressed in μ sec and is derived by dividing 1000 by the clock speed

expressed in MHz. So, 50 MHz is $1000/50=20$ ns, or $0.02 \mu\text{s}$. A typical SDRAM is 4096 rows per bank if the system clock is running at 50 MHz with an **EPIBAUD** register value of 0:

$$RFSH = (64000/4096) / 0.02 = 15.625 \mu\text{s} / 0.02 \mu\text{s} = 781.25$$

The default value in the `RFSH` field is 750 decimal or `0x2EE` to allow for a margin of safety and providing $15 \mu\text{s}$ per refresh. It is important to note that this number should always be smaller or equal to what is required by the above equation. For example, if running the external clock at 25 MHz (40 ns per clock period), 390 is the highest number that may be used. Note that the external clock may be 25 MHz when the system clock is 25 MHz or when the system clock is 50 MHz and configuring the `COUNT0` field in the **EPIBAUD** register to 1 (divide by 2).

If a number larger than allowed is used, the SDRAM is not refreshed often enough, and data is lost.

11.4.2.3 Bus Interface Speed

The EPI Controller SDRAM interface can operate up to 60 MHz. The `COUNT0` field in the **EPIBAUD** register configures the speed of the EPI clock. For system clock (`SysClk`) speeds up to 60 MHz, the `COUNT0` field can be `0x0000`, and the SDRAM interface can run at the same speed as `SysClk`. However, if `SysClk` is running at higher speeds, the bus interface can run only as fast as half speed, and the `COUNT0` field must be configured to at least `0x0001`.

11.4.2.4 Non-Blocking Read Cycle

Figure 11-2 on page 832 shows a non-blocking read cycle of n halfwords; n can be any number greater than or equal to 1. The cycle begins with the Activate command and the row address on the `EPIOS[15:0]` signals. With the programmed CAS latency of 2, the Read command with the column address on the `EPIOS[15:0]` signals follows after 2 clock cycles. Following one more NOP cycle, data is read in on the `EPIOS[15:0]` signals on every rising clock edge. The Burst Terminate command is issued during the cycle when the next-to-last halfword is read in. The `DQMH` and `DQML` signals are deasserted after the last halfword of data is received; the `CSn` signal deasserts on the following clock cycle, signaling the end of the read cycle. At least one clock period of inactivity separates any two SDRAM cycles.

Figure 11-2. SDRAM Non-Blocking Read Cycle

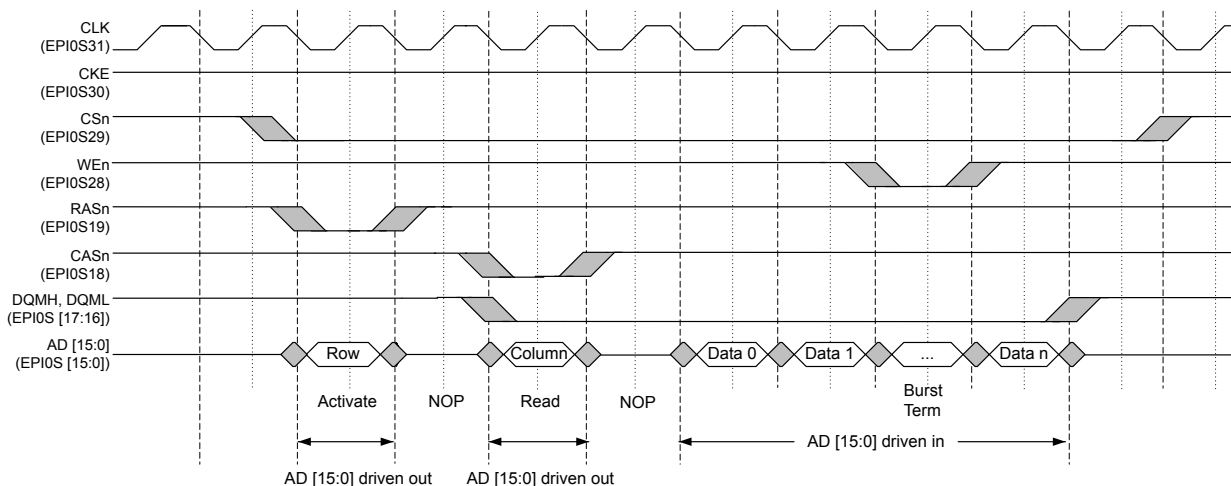

11.4.2.5 Normal Read Cycle

Figure 11-3 on page 833 shows a normal read cycle of n halfwords; n can be 1 or 2. The cycle begins with the Activate command and the row address on the $EPIOS[15:0]$ signals. With the programmed CAS latency of 2, the Read command with the column address on the $EPIOS[15:0]$ signals follows after 2 clock cycles. Following one more NOP cycle, data is read in on the $EPIOS[15:0]$ signals on every rising clock edge. The DQMH, DQML, and CSn signals are deasserted after the last halfword of data is received, signaling the end of the cycle. At least one clock period of inactivity separates any two SDRAM cycles.

Figure 11-3. SDRAM Normal Read Cycle

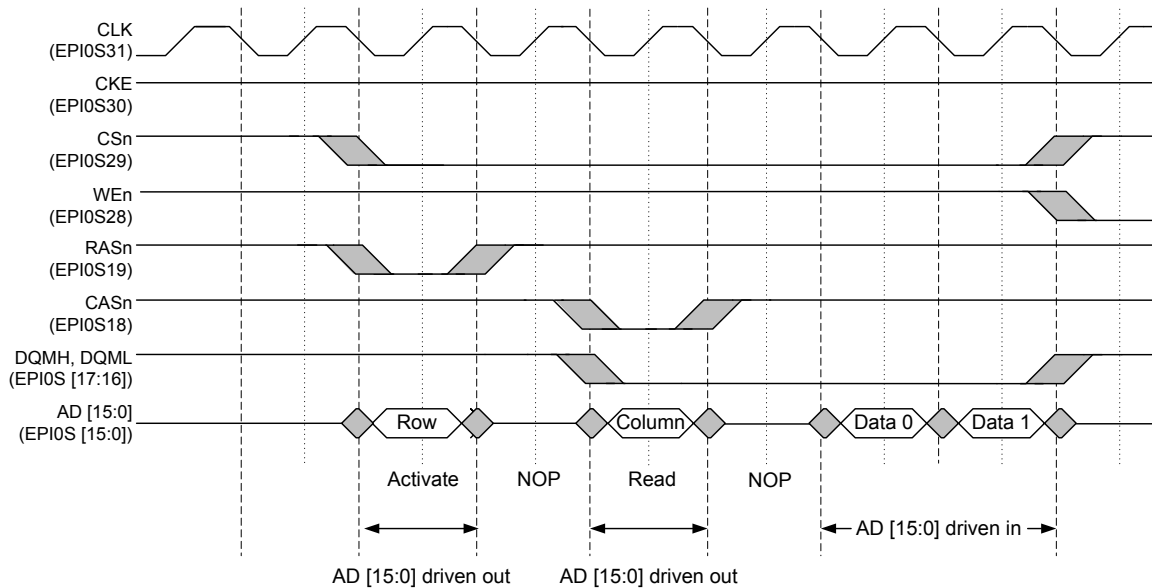

11.4.2.6 Write Cycle

Figure 11-4 on page 834 shows a write cycle of n halfwords; n can be any number greater than or equal to 1. The cycle begins with the Activate command and the row address on the $EPIOS[15:0]$ signals. With the programmed CAS latency of 2, the Write command with the column address on the $EPIOS[15:0]$ signals follows after 2 clock cycles. When writing to SDRAMs, the Write command is presented with the first halfword of data. Because the address lines and the data lines are multiplexed, the column address is modified to be (programmed address - 1). During the Write command, the DQMH and DQML signals are high, so no data is written to the SDRAM. On the next clock, the DQMH and DQML signals are asserted, and the data associated with the programmed address is written. The Burst Terminate command occurs during the clock cycle following the write of the last halfword of data. The WEn, DQMH, DQML, and CSn signals are deasserted after the last halfword of data is received, signaling the end of the access. At least one clock period of inactivity separates any two SDRAM cycles.

Figure 11-4. SDRAM Write Cycle

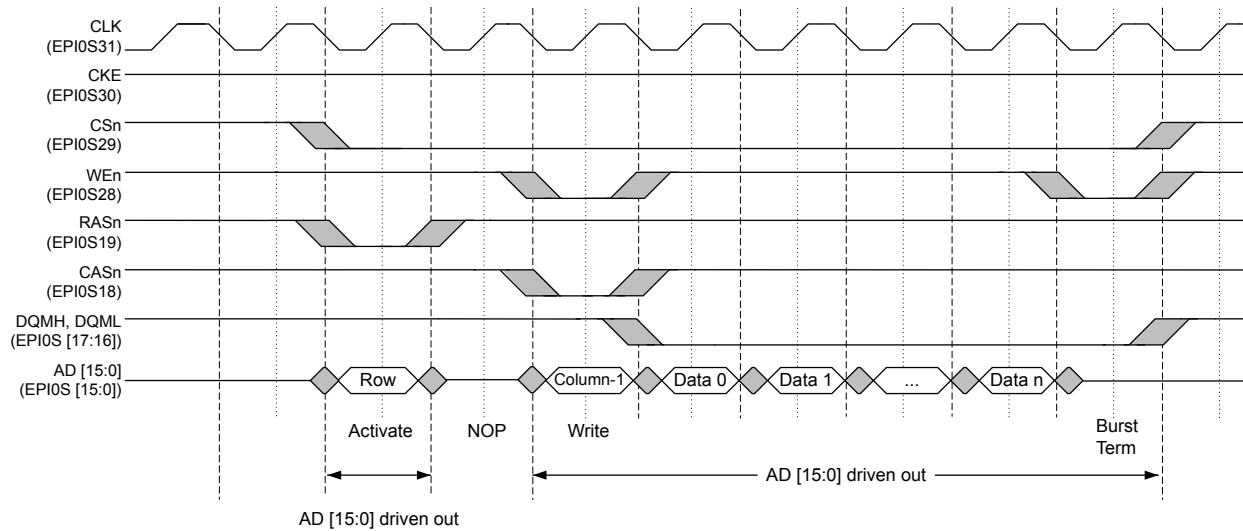

11.4.3 Host Bus Mode

Host Bus supports the traditional 8-bit and 16-bit interfaces popularized by the 8051 devices and SRAM devices, as well as PSRAM and NOR Flash memory. This interface is asynchronous and uses strobe pins to control activity. Addressable memory can be doubled using Host Bus-16 mode as it performs half-word accesses. The `EPIOS0` is the LSB of the address and is equivalent to the internal Cortex-M4 A1 address. `EPIOS0` should be connected to A0 of 16-bit memories.

11.4.3.1 Control Pins

The main three strobes are Address Latch Enable (ALE), Write (`WRn`), and Read (`RDn`, sometimes called `OEn`). Note that the timings are designed for older logic and so are hold-time versus setup-time specific. The polarity of the read and write strobes can be active High or active Low by clearing or setting the `RDHIGH` and `WRHIGH` bits in the **EPI Host-Bus n Configuration (EPIHBnCFGn)** register.

The ALE can be changed to an active-low chip select signal, `CSn`, through the **EPIHBnCFGn** register. The ALE is best used for Host-Bus muxed mode in which EPI address and data pins are shared. All Host-Bus accesses have an address phase followed by a data phase. The ALE indicates to an external latch to capture the address then hold it until the data phase. The polarity of the ALE can be active High or Low by clearing or setting the `ALEHIGH` bit in the **EPI Host-Bus n Configuration (EPIHBnCFGn)** register. `CSn` is best used for Host-Bus unmuxed mode in which EPI address and data pins are separate. The `CSn` indicates when the address and data phases of a read or write access are occurring. Both the ALE and the `CSn` modes can be enhanced to access four external devices using settings in the **EPIHBnCFGn** register. PSRAM accesses must use both ALE and `CSn`. Wait states can be added to the data phase of the access using the `WRWS` and `RDWS` bits in the **EPIHBnCFGn** register. Additionally, within these wait state options, the `WRWSM` and `RDWSM` bit of the **EPIHBnTIMEn** register can be set to reduce the given wait states by 1 EPI clock cycle for finer granularity.

For FIFO mode, the ALE is not used, and two input holds are optionally supported to gate input and output to what the XFIFO can handle. FIFO mode is only applicable in EPI asynchronous mode.

Host-Bus 8 and Host-Bus 16 modes are very configurable. The user has the ability to connect 1, 2, or 4 external devices to the EPI signals, as well as control whether byte select signals are provided in HB16 mode. These capabilities depend on the configuration of the `MODE` field in the **EPIHBnCFGn**

register, the **CSCFG** field and the **CSCFGEXT** bit in the **EPIHBnCFGn** register, and the **BSEL** bit in the **EPIHB16CFG** register. The **CSCFGEXT** bit extends the chip select configuration possibilities by providing the most significant bit of the **CSCFG** field. Refer to Table 11-4 on page 835 for the possible ALE and chip select options that can be programmed by the combination of the **CSCFGEXT** and **CSCFG** bits. Note that **CSCFGEXT** is the most significant bit.

Table 11-4. CSCFGEXT + CSCFG Encodings

Value	Description
0x0	ALE Configuration EPIOS30 is used as an address latch (ALE). The ALE signal is generally used when the address and data are muxed (MODE field in the EPIHB8CFG register is 0x0). The ALE signal is used by an external latch to hold the address through the bus cycle.
0x1	CSn Configuration EPIOS30 is used as a Chip Select (CSn). When using this mode, the address and data are generally not muxed (MODE field in the EPIHB8CFG register is 0x1). However, if address and data muxing is needed, the WR signal (EPIOS29) and the RD signal (EPIOS28) can be used to latch the address when CSn is low.
0x2	Dual CSn Configuration EPIOS30 is used as CS0n and EPIOS27 is used as CS1n. Whether CS0n or CS1n is asserted is determined by the most significant address bit for a respective external address map. This configuration can be used for a RAM bank split between 2 devices as well as when using both an external RAM and an external peripheral.
0x3	ALE with Dual CSn Configuration EPIOS30 is used as address latch (ALE), EPIOS27 is used as CS1n, and EPIOS26 is used as CS0n. Whether CS0n or CS1n is asserted is determined by the most significant address bit for a respective external address map.
0x4	ALE with Single CSn Configuration EPIOS30 is used as address latch (ALE) and EPIOS27 is used as CSn.
0x5	Quad CSn Configuration EPIOS30 is used as CS0n and EPIOS27 is used as CS1n. EPIOS34 is used as CS2n and EPIOS33 is used as CS3n.
0x6	ALE with Quad CSn Configuration EPIOS30 is ALE, EPIOS26 is CS0n and EPIOS27 is used as CS1n. EPIOS34 is used as CS2n and EPIOS33 is used as CS3n.
0x7	Reserved

If one of the Dual-Chip-Select modes is selected (**CSCFGEXT** is 0x0 and **CSCFG** is 0x2 or 0x3 in the **EPIHBnCFGn** register), both chip selects can share the peripheral, code, or the memory space, or one chip select can use the peripheral space and the other can use the memory or code space. In the **EPIADDRMAP** register, if the **EPADR** field is not 0x0, the **ECADR** field is 0x0, and the **ERADR** field is 0x0, then the address specified by **EPADR** is used for both chip selects, with **CS0n** being asserted when the MSB of the address range is 0 and **CS1n** being asserted when the MSB of the address range is 1. If the **ERADR** field is not 0x0, the **ECADR** field is 0x0, and the **EPADR** field is 0x0, then the address specified by **ERADR** is used for both chip selects, with the MSB performing the same delineation. If both the **EPADR** and the **ERADR** are not 0x0, and the **ECADR** field is 0x0 and the EPI is configured for dual-chip selects, then **CS0n** is asserted for either address range defined by **EPADR** and **CS1n** is asserted for either address range defined by **ERADR**. The two chip selects can also be shared between the code space and memory or peripheral space. If the **ECADR** field is 0x1, **ERADR** field is 0x0, and the **EPADR** field is not 0x0, then **CS0n** is asserted for the address range defined by **ECADR** and **CS1n** is asserted for either address range defined by **EPADR**. If the **ECADR** field is 0x1, **EPADR** field is 0x0, and the **ERADR** field is not 0x0, then **CS0n** is asserted for the address range defined by **ECADR** and **CS1n** is asserted for either address range defined by **ERADR**.

In quad chip select mode (`CSCFGEXT` is 0x1 and `CSCFG` is 0x1 or 0x2 in the **EPIHBnCFG2** register), both the peripheral and the memory space must be enabled. In the **EPIADDRMAP** register, the `EPADR` field is 0x3, the `ERADR` field is 0x3, and the `ECADR` field is 0x0. With this configuration, `CS0n` asserts for the address range beginning at 0x6000.0000, `CS1n` asserts for 0x8000.0000, `CS2n` for 0xA000.0000, and `CS3n` for 0xC000.0000. Table 11-5 on page 836 gives a detailed explanation of chip select address range mappings based on combinations of enabled peripheral and memory space.

Note: Only one memory area can be mapped to a single chip select. Enabling multiple memory areas for one chip select may produce unexpected results.

Table 11-5. Dual- and Quad- Chip Select Address Mappings

Chip Select Mode	ERADR	EPADR	ECADR	CS0 ^a	CS1	CS2	CS3
Dual-chip select	0x0	0x1 or 0x2	0x0	EPADR defined address range (0xA000.000 or 0xC000.0000)	EPADR defined address range (0xA000.000 or 0xC000.0000)	N/A	N/A
Dual-chip select	0x1 or 0x2	0x0	0x0	ERADR defined address range (0x6000.000 or 0x8000.000)	ERADR defined address range (0x6000.000 or 0x8000.000)	N/A	N/A
Dual-chip select	0x1 or 0x2	0x1 or 0x2	0x0	EPADR defined address range (0xA000.000 or 0xC000.0000)	ERADR defined address range (0x6000.000 or 0x8000.000)	N/A	N/A
Dual-chip select	0x0	0x1 or 0x2	0x1	ECADR defined address range (0x1000.000)	EPADR defined address range (0xA000.0000 or 0xC000.0000)	N/A	N/A
Dual-chip select	0x1 or 0x2	0x0	0x1	ECADR defined address range (0x1000.000)	ERADR defined address range (0x6000.000 or 0x8000.000)	N/A	N/A
Quad-chip select	0x3	0x3	0x0	0x6000.0000	0x8000.0000	0xA000.0000	0xC000.0000

a. When `CS0` & `CS1` share address space, `CS0` asserts when the MSB of the address is 0 and `CS1`, when the MSB of the address is '1.'

The `MODE` field of the **EPIHBnCFGn** registers configure the interface for the chip selects, which support `ADMUX` or `ADNOMUX`. See Table 11-6 on page 837 for details on which configuration register controls each chip select. If the `CSBAUD` bit is clear, all chip selects are configured by the `MODE` bit field of the **EPIHBnCFG** register.

If the `CSBAUD` bit in the **EPIHBnCFG2** register is set in Dual-chip select mode, the 2 chip selects can use different clock frequencies, wait states and strobe polarity. If the `CSBAUD` bit is clear, both chip selects use the clock frequency, wait states, and strobe polarity defined for `CS0n`. Additionally, if the `CSBAUD` bit is set, the two chip selects can use different interface modes. If any interface modes are programmed to `ADMUX`, then dual chip select mode must include the ALE capability. In quad chip select mode, if the `CSBAUD` bit in the **EPIHBnCFG2** register is set, the 4 chip selects can use different clock frequencies, wait states and strobe polarity. If the `CSBAUD` bit is clear, all chip selects use the clock frequency, wait states, and strobe polarity defined for `CS0n`. If the `CSBAUD` bit is set, the four chip selects can use different interface modes.

Table 11-6. Chip Select Configuration Register Assignment

Configuration Register ^a	Corresponding Chip Select
EPIHBnCFG	CS0n
EPIHBnCFG2	CS1n
EPIHBnCFG3	CS2n
EPIHBnCFG4	CS3n

a. If the CSBAUD bit in the **EPIHBnCFG2** register is clear and multiple chip selects are enabled, then all chip selects are configured by the MODE bit field in the **EPIHBnCFG** register.

Note that multiple chip select modes do not allow the intermixing of Host-Bus 8 and Host-Bus16 modes.

When BSEL=1 in the **EPIHB16CFG** register, byte select signals are provided, so byte-sized data can be read and written at any address, however these signals reduce the available address width by 2 pins. The byte select signals are active Low. BSEL0n corresponds to the LSB of the halfword, and BSEL1n corresponds to the MSB of the halfword.

When BSEL=0, byte reads and writes at odd addresses only act on the even byte, and byte writes at even addresses write invalid values into the odd byte. As a result, accesses should be made as half-words (16-bits) or words (32-bits). In C/C++, programmers should use only short int and long int for accesses. Also, because data accesses in HB16 mode with no byte selects are on 2-byte boundaries, the available address space is doubled. For example, 28 bits of address accesses 512 MB in this mode. Table 11-7 on page 837 shows the capabilities of the HB8 and HB16 modes as well as the available address bits with the possible combinations of these bits.

Although the EPI0S31 signal can be configured for the EPI clock signal in Host-Bus mode, it is not required and should be configured as a GPIO to reduce EMI in the system.

Table 11-7. Capabilities of Host Bus 8 and Host Bus 16 Modes

Host Bus Type	MODE	CSCFGEXT	CSCFG	Max # of External Devices	BSEL	Byte Access	Available Address	Addressable Memory
HB8	0x0	0	0x0, 0x1	1	N/A	Always	28 bits	256 MB
HB8	0x0	0	0x2	2	N/A	Always	27 bits	128 MB
HB8	0x0	0	0x3	2	N/A	Always	26 bits	64 MB
HB8	0x0	1	0x0	1	N/A	Always	27 bits	128 MB
HB8	0x0	1	0x1	4	N/A	Always	27 bits	128 MB
HB8	0x0	1	0x2	4	N/A	Always	26 bits	64 MB
HB8	0x1	0	0x0, 0x1	1	N/A	Always	20 bits	1 MB
HB8	0x1	0	0x2	2	N/A	Always	19 bits	512 kB
HB8	0x1	0	0x3	2	N/A	Always	18 bits	256 kB
HB8	0x1	1	0x0	1	N/A	Always	19 bits	512 kB
HB8	0x1	1	0x1	4	N/A	Always	19 bits	512 MB
HB8	0x1	1	0x2	4	N/A	Always	18 bits	256 kB
HB8	0x2	0	0x1	1	N/A	Always	20 bits	1 MB
HB8	0x3	0	0x1	1	N/A	Always	none	-
HB8	0x3	0	0x3	2	N/A	Always	none	-
HB8	0x3	1	0x0	1	N/A	Always	none	-
HB8	0x3	1	0x1	4	N/A	Always	none	-

Table 11-7. Capabilities of Host Bus 8 and Host Bus 16 Modes (continued)

Host Bus Type	MODE	CSCFGEXT	CSCFG	Max # of External Devices	BSEL	Byte Access	Available Address	Addressable Memory
HB8	0x3	1	0x2	4	N/A	Always	none	-
HB16	0x0	0	0x0, 0x1	1	0	No	28 bits ^a	512 MB
HB16	0x0	0	0x0, 0x1	1	1	Yes	26 bits ^b	128 MB
HB16	0x0	0	0x2	2	0	No	27 bits ^a	256 MB
HB16	0x0	0	0x2	2	1	Yes	25 bits ^b	64 MB
HB16	0x0	0	0x3	2	0	No	26 bits ^a	128 MB
HB16	0x0	0	0x3	2	1	Yes	24 bits ^b	32 MB
HB16	0x0	1	0x0	1	0	No	27 bits ^a	256 MB
HB16	0x0	1	0x0	1	1	Yes	25 bits ^b	128 MB
HB16	0x0	1	0x1	4	0	No	27 bits ^a	256 MB
HB16	0x0	1	0x1	4	1	Yes	25 bits ^b	64 MB
HB16	0x0	1	0x2	4	0	No	26 bits ^a	128 MB
HB16	0x0	1	0x2	4	1	Yes	24 bits ^b	32 MB
HB16	0x1	0	0x0, 0x1	1	0	No	12 bits ^a	8 kB
HB16	0x1	0	0x0, 0x1	1	1	Yes	10 bits ^b	2 kB
HB16	0x1	0	0x2	2	0	No	11 bits ^a	4 kB
HB16	0x1	0	0x2	2	1	Yes	9 bits ^b	1 kB
HB16	0x1	0	0x3	2	0	No	10 bits ^a	2 kB
HB16	0x1	0	0x3	2	1	Yes	8 bits ^b	512 B
HB16	0x1	1	0x0	1	0	No	11 bits ^a	4 kB
HB16	0x1	1	0x0	1	1	Yes	9 bits ^b	1 kB
HB16	0x1	1	0x1	4	0	No	11 bits ^a	4 kB
HB16	0x1	1	0x1	4	1	Yes	9 bits ^b	1 kB
HB16	0x1	1	0x2	4	0	No	10 bits ^a	2 kB
HB16	0x1	1	0x2	4	1	Yes	8 bits ^b	512 B
HB16	0x3	0	0x1	1	0	No	none	-
HB16	0x3	0	0x1	1	1	Yes	none	-
HB16	0x3	0	0x3	2	0	No	none	-
HB16	0x3	0	0x3	2	1	Yes	none	-
HB16	0x3	1	0x0	1	0	No	none	-
HB16	0x3	1	0x0	1	1	Yes	none	-
HB16	0x3	1	0x1	4	0	No	none	-
HB16	0x3	1	0x1	4	1	Yes	none	-
HB16	0x3	1	0x2	4	0	No	none	-
HB16	0x3	1	0x2	4	1	Yes	none	-

a. If byte selects are not used, data accesses are on 2-byte boundaries. As a result, the available address space is doubled.

b. Two EPI signals are used for byte selects, reducing the available address space by two bits.

Table 11-8 on page 839 shows how the EPI[31:0] signals function while in Host-Bus 8 mode. Notice that the signal configuration changes based on the address/data mode selected by the MODE

field in the **EPIHB8CFGn** register and on the chip select configuration selected by the **CSCFG** and **CSCFGEXT** field in the **EPIHB8CFG2** register.

Although the **EPI0S31** signal can be configured for the EPI clock signal in Host-Bus mode, it is not required and should be configured as a GPIO to reduce EMI in the system. Any unused EPI controller signals can be used as GPIOs or another alternate function.

Table 11-8. EPI Host-Bus 8 Signal Connections

EPI Signal	CSCFG	HB8 Signal (MODE =ADMUX)	HB8 Signal (MODE =ADNOMUX (Cont. Read))	HB8 Signal (MODE =XFIFO)
EPI0S0	X ^a	AD0	D0	D0
EPI0S1	X	AD1	D1	D1
EPI0S2	X	AD2	D2	D2
EPI0S3	X	AD3	D3	D3
EPI0S4	X	AD4	D4	D4
EPI0S5	X	AD5	D5	D5
EPI0S6	X	AD6	D6	D6
EPI0S7	X	AD7	D7	D7
EPI0S8	X	A8	A0	-
EPI0S9	X	A9	A1	-
EPI0S10	X	A10	A2	-
EPI0S11	X	A11	A3	-
EPI0S12	X	A12	A4	-
EPI0S13	X	A13	A5	-
EPI0S14	X	A14	A6	-
EPI0S15	X	A15	A7	-
EPI0S16	X	A16	A8	-
EPI0S17	X	A17	A9	-
EPI0S18	X	A18	A10	-
EPI0S19	X	A19	A11	-
EPI0S20	X	A20	A12	-
EPI0S21	X	A21	A13	-
EPI0S22	X	A22	A14	-
EPI0S23	X	A23	A15	-
EPI0S24	X	A24	A16	-
EPI0S25	0x0	A25 ^b	A17	-
	0x1			CS1n
	0x2			
	0x3			
	0x4			
	0x5			
	0x6			

Table 11-8. EPI Host-Bus 8 Signal Connections (*continued*)

EPI Signal	CSCFG	HB8 Signal (MODE =ADMUX)	HB8 Signal (MODE =ADNOMUX (Cont. Read))	HB8 Signal (MODE =XFIFO)
EPI0S26	0x0	A26	A18	FEMPTY
	0x1			
	0x2			
	0x3	CS0n	CS0n	
	0x4	A26	A18	
	0x5			
	0x6	CS0n	CS0n	
EPI0S27	0x0	A27	A19	FFULL
	0x1			
	0x2	CS1n	CS1n	
	0x3			
	0x4	CS0n	CS0n	
	0x5	CS1n	CS1n	
	0x6			
EPI0S28	X	RDn/OEn	RDn/OEn	RDn
EPI0S29	X	WRn	WRn	WRn
EPI0S30	0x0	ALE	ALE	-
	0x1	CSn	CSn	CSn
	0x2	CS0n	CS0n	CS0n
	0x3	ALE	ALE	-
	0x4			-
	0x5	CS0n	CS0n	-
	0x6	ALE	ALE	-
EPI0S31	X	Clock ^c	Clock ^c	Clock ^c
EPI0S32	X	iRDY	iRDY	iRDY
EPI0S33	0x0	X	X	X
	0x1	X	X	X
	0x2	X	X	X
	0x3	X	X	X
	0x4	X	X	X
	0x5	CS3n	CS3n	X
	0x6			X
EPI0S34	0x0	X	X	X
	0x1	X	X	X
	0x2	X	X	X
	0x3	X	X	X
	0x4	X	X	X
	0x5	CS2n	CS2n	X
	0x6			X

Table 11-8. EPI Host-Bus 8 Signal Connections (continued)

EPI Signal	CSCFG	HB8 Signal (MODE =ADMUX)	HB8 Signal (MODE =ADNOMUX (Cont. Read))	HB8 Signal (MODE =XFIFO)
EPI0S35	0x0	X	X	X
	0x1	X	X	X
	0x2	X	X	X
	0x3	X	X	X
	0x4	X	X	X
	0x5	CRE	CRE	X
	0x6			X

a. "X" indicates the state of this field is a don't care.

b. When an entry straddles several row, the signal configuration is the same for all rows.

c. The clock signal is not required for this mode.

Table 11-9 on page 841 shows how the EPI[31:0] signals function while in Host-Bus 16 mode. Notice that the signal configuration changes based on the address/data mode selected by the MODE field in the EPIHB16CFGn register, on the chip select configuration selected by the CSCFG and CSCFGEXT field in the same register, and on whether byte selects are used as configured by the BSEL bit in the EPIHB16CFG register.

Although the EPI0S31 signal can be configured for the EPI clock signal in Host-Bus mode, it is not required and should be configured as a GPIO to reduce EMI in the system. Any unused EPI controller signals can be used as GPIOs or another alternate function.

Table 11-9. EPI Host-Bus 16 Signal Connections

EPI Signal	CSCFG	BSEL	HB16 Signal (MODE =ADMUX)	HB16 Signal (MODE =ADNOMUX (Cont. Read))	HB16 Signal (MODE =XFIFO)
EPI0S0	X ^a	X	AD0 ^b	D0	D0
EPI0S1	X	X	AD1	D1	D1
EPI0S2	X	X	AD2	D2	D2
EPI0S3	X	X	AD3	D3	D3
EPI0S4	X	X	AD4	D4	D4
EPI0S5	X	X	AD5	D5	D5
EPI0S6	X	X	AD6	D6	D6
EPI0S7	X	X	AD7	D7	D7
EPI0S8	X	X	AD8	D8	D8
EPI0S9	X	X	AD9	D9	D9
EPI0S10	X	X	AD10	D10	D10
EPI0S11	X	X	AD11	D11	D11
EPI0S12	X	X	AD12	D12	D12
EPI0S13	X	X	AD13	D13	D13
EPI0S14	X	X	AD14	D14	D14
EPI0S15	X	X	AD15	D15	D15
EPI0S16	X	X	A16	A0 ^b	-
EPI0S17	X	X	A17	A1	-

Table 11-9. EPI Host-Bus 16 Signal Connections (continued)

EPI Signal	CSCFG	BSEL	HB16 Signal (MODE =ADMUX)	HB16 Signal (MODE =ADNOMUX (Cont. Read))	HB16 Signal (MODE =XFIFO)					
EPIOS18	X	X	A18	A2	-					
EPIOS19	X	X	A19	A3	-					
EPIOS20	X	X	A20	A4	-					
EPIOS21	X	X	A21	A5	-					
EPIOS22	X	X	A22	A6	-					
EPIOS23	X ^c	0	A23	A7	-					
		1								
EPIOS24	0x0	0	A24	A8	-					
		1								
	0x1	0								
		1								
	0x2	0								
		1								
	0x3	0				BSEL0n	BSEL0n			
		1								
	0x4	0				A24	A8	-		
		1								
	0x5	0								
		1								
	0x6	0						BSEL0n	BSEL0n	-
		1								
EPIOS25	0x0	X	A25	A9	-					
								0x1		
	0x2	0	A25	A9	CS1n					
		1	BSEL0n	BSEL0n						
	0x3	0	A25	A9	--					
		1	BSEL1n	BSEL1n						
	0x4	0	A25	A9	-					
		1	BSEL0n	BSEL0n						
	0x5	0	A25	A9	-					
		1	BSEL0n	BSEL0n						
	0x6	0	A25	A9	-					
		1	BSEL1n	BSEL1n						

Table 11-9. EPI Host-Bus 16 Signal Connections (continued)

EPI Signal	CSCFG	BSEL	HB16 Signal (MODE =ADMUX)	HB16 Signal (MODE =ADNOMUX (Cont. Read))	HB16 Signal (MODE =XFIFO)
EPIOS26	0x0	0	A26	A10	EMPTY
		1	BSEL0n	BSEL0n	
	0x1	0	A26	A10	
		1	BSEL0n	BSEL0n	
	0x2	0	A26	A10	
		1	BSEL1n	BSEL1n	
	0x3	X	CS0n	CS0n	
	0x4	0	A26	A10	-
		1	BSEL1n	BSEL1n	
	0x5	0	A26	A10	-
		1	BSEL1n	BSEL1n	
	0x6	0	CS0n	CS0n	-
1					
EPIOS27	0x0	0	A27	A11	FULL
		1	BSEL1n	BSEL1n	
	0x1	0	A27	A11	
		1	BSEL1n	BSEL1n	
	0x2	X	CS1n	CS1n	
	0x3	X	CS1n	CS1n	
	0x4	X	CS0n	CS0n	-
0x5	X	CS1n	CS1n	-	
0x6	X	CS1n	CS1n	-	
EPIOS28	X	X	RDn/OEn	RDn/OEn	RDn
EPIOS29	X	X	WRn	WRn	WRn
EPIOS30	0x0	X	ALE	ALE	-
	0x1	X	CSn	CSn	CSn
	0x2	X	CS0n	CS0n	CS0n
	0x3	X	ALE	ALE	-
	0x4	X	ALE	ALE	-
	0x5	X	CS0n	CS0n	-
	0x6	X	ALE	ALE	-
EPIOS31	X	X	Clock ^d	Clock ^d	Clock ^d
EPIOS32	X	X	iRDY	iRDY	iRDY
EPIOS33	X	X	CS3n	CS3n	X
EPIOS34	X	X	CS2n	CS2n	X
EPIOS35	X	X	CRE	CRE	X

a. "X" indicates the state of this field is a don't care.

b. In this mode, half-word accesses are used. A0 is the LSB of the address and is equivalent to the internal Cortex-M3 A1 address. This pin should be connected to A0 of 16-bit memories.

c. When an entry straddles several row, the signal configuration is the same for all rows.

d. The clock signal is not required for this mode.

The `RDYEN` in the `EPIHBnCFG` enables the monitoring of the external `iRDY` pin to stall accesses. On the rising edge of EPI clock, if `iRDY` is low, access is stalled. The `IRDYDLY` can program the number of EPI clock cycles in advance to the stall (1,2 or 3) as shown in Figure 11-5 on page 844. This is a conceptual timing diagram of how the `iRDY` signal works with different `IRDYDLY` configurations. When enabled, the `iRDY` stalls the EPI's internal states, while `IRDYDLY` controls the delay pipeline when this stall takes affect. The `iRDY` signal can be connected to multiple devices with a pull up resistor as shown in Figure 11-6 on page 844. Note that when multiple PSRAMs are connected to `iRDY`, the `EPIHPnCFG` registers must be programmed to the same `iRDY` signal polarity through the `IRDYINV` bit. When connected to a PSRAM, `iRDY` is used to control the address to data latency.

Figure 11-5. `iRDY` Access Stalls, `IRDYDLY==01, 10, 11`

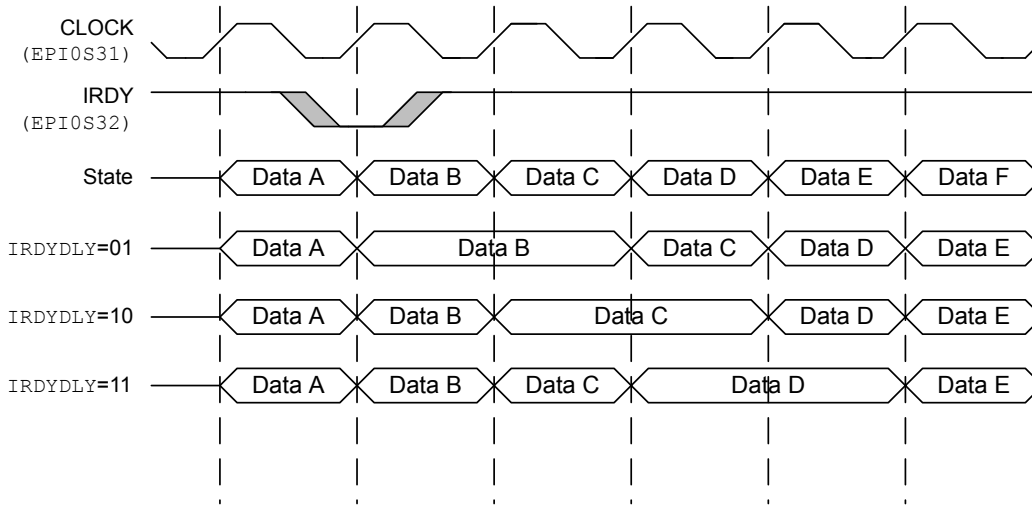
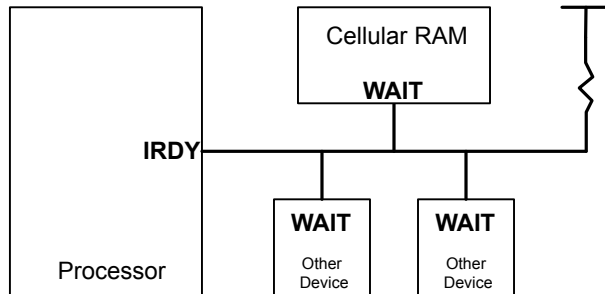

Figure 11-6. `iRDY` Signal Connection



11.4.3.2 PSRAM Support

The EPI Host Bus supports both a synchronous and asynchronous interface to PSRAM memory when configured in 16-bit bus multiplexed mode. The `EPIHBPSRAM` register holds the values for the PSRAM's bus configuration registers (CR). The contents of the `EPIHBPSRAM` register can be sent to different memories depending on which `WRCRE` or `RDCRE` bit is set in the various `EPIHB16CFGn` registers. For example, if the `WRCRE` bit is enabled in `EPIHB16CFG`, then the `CRE` signal asserts and the contents are sent to the memory enabled by `CS0`. Enabling the `WRCRE` or `RDCRE` bit in `EPIHB16CFG2` register activates `CS1n` during a PSRAM configuration register write or read. The `WRCRE` and `RDCRE` bit in `EPIHB16CFG3` corresponds to `CS2n` and `EPIHB16CFG4`, to `CS3n`. The `WRCRE` bit clears when the transfer is done. There must not be any system access or

non-blocking read activity during the CRE read or write-enable transfer. During a write to the PSRAM's CR, the configuration data is written out on data pins [20:0] of the EPI bus. For a PSRAM configuration read access, the `RDCRE` bit in the **EPIHB16CFG** register is set to signal that the next access is a read of the PSRAM configuration register (CR). The address for the CR is written to bits `CR[19:18]` of the **EPIHBPSRAM** register. The read data is returned at `CR` bits [15:0] of the **EPIHBPSRAM** register.

- Note:**
- CRE read and write operations may only occur in asynchronous mode. During synchronous mode the CRE bit should be disabled. Setting the CRE bit during synchronous PSRAM accesses can lead to unpredictable behavior.
 - When the chip select is programmed to access the PSRAM, the `MODE` bit of the **EPIHBnCFGn** register must be programmed to enable address and data muxed (ADMUX). Page mode accesses are not supported by the EPI.
 - BURST is optimized for word-length bursting for SDRAM and PSRAM accesses.

The subsequent list identifies the steps for initializing the PSRAM interface:

1. Follow the EPI initialization steps in “Initialization and Configuration” on page 829.
2. Enable Host Bus 16 Mode by setting the `MODE` bits in the **EPICFG** register to 0x13. Choose between an integer or formula clock divide for the baud rate by configuring the `INTDIV` bit in the **EPICFG** register.
3. Configure the **EPIBAUD** register to the desired baud rate.
4. Since the EPI module only supports asynchronous programming of the configuration registers, clock gate the EPI clock by programming both the `CLKGATE` and `CLKGATEI` bits in the **EPIHB16CFG** register to 0.
5. Prepare for writing the PSRAM's Bus Configuration Register by setting the `ALEHIGH = 1` and `MODE=0x0` in the **EPIHB16CFG** register.
6. Program the **EPIHBPSRAM** register to be loaded into the CR register of the PSRAM by configuring bits [21:0].
 - `CR[20:19] = 0x0`, reserved
 - `CR[19:18] = 0x2` to enable configuring of the CR register
 - `CR[15] = 0x1` to enable asynchronous access
 - `CR[14] = 0` if the `iRDY` signal is used for memory transfers; if the design will not use the `iRDY` signal `CR[14]` should be cleared.
 - `CR[13:11]` must be programmed to have a matching read and write wait state configuration as is programmed in the **EPIHB16CFG** and **EPIHB16TIME** register.
 - `CR[10]` configures the polarity of the `WAIT` signal and should match the configuration of the `IRDYINV` bit in the **EPIHB16CFG** register.
 - `CR[8] = 0x1` to configure the appropriate wait configuration of the data
 - `CR[2:0] = 0x7` since the EPI interface in PSRAM mode is a continuous burst access.

7. Set the `WRCRE` bit in the **EPIHB16CFGn** register to initiate a write from the **EPIHBPSRAM** register to PSRAM's CR register.

Note: If the PSRAM's CR register must be reprogrammed after initialization, the application should allow the previous transfer to complete before beginning configuration to ensure proper PSRAM functionality.

Table 11-10. PSRAM Fixed Latency Wait State Configuration

Latency Counter	Latency in Clocks	RDWS[1:0]/WRWS[1:0]	RWSM/WRWSM
BCR Code 2	3	0x0	0
BCR Code 3	4	0x1	1
BCR Code 4	5	0x1	0
BCR Code 5	6	0x2	1
BCR Code 6	7	0x2	0
BCR Code 8	9	0x3	0

In variable initial latency mode, the memory's WAIT (iRDY) pin guides the EPI module when to read and write. The WAIT (iRDY) pin stalls the access for the duration of the latency and adds cycles if there is a refresh collision. To get the best performance, set `CR[13:11] = 0x2`, the `WRWS` field of the **EPIHB16CFG** register to 0x0, and the `WRWSM` and `RDWSM` bit of the **EPI16TIMEn** register to 0. For the WAIT pin to be recognized correctly set the `IRDYDLY` bit in the **EPI16TIMEn** register to 1 and the `CR[8] = 1` in the **EPIHBPSRAM** register.

Note: Wait state latency works differently in PSRAM Burst mode than in other modes. In PSRAM Burst mode the `RDWS` and `WRWS` bit fields define the latency for only the first access of the write or read cycle. Every access after that is a single access.

Figure 11-7 on page 847 and Figure 11-8 on page 847 depict a PSRAM burst read and write.

Figure 11-7. PSRAM Burst Read

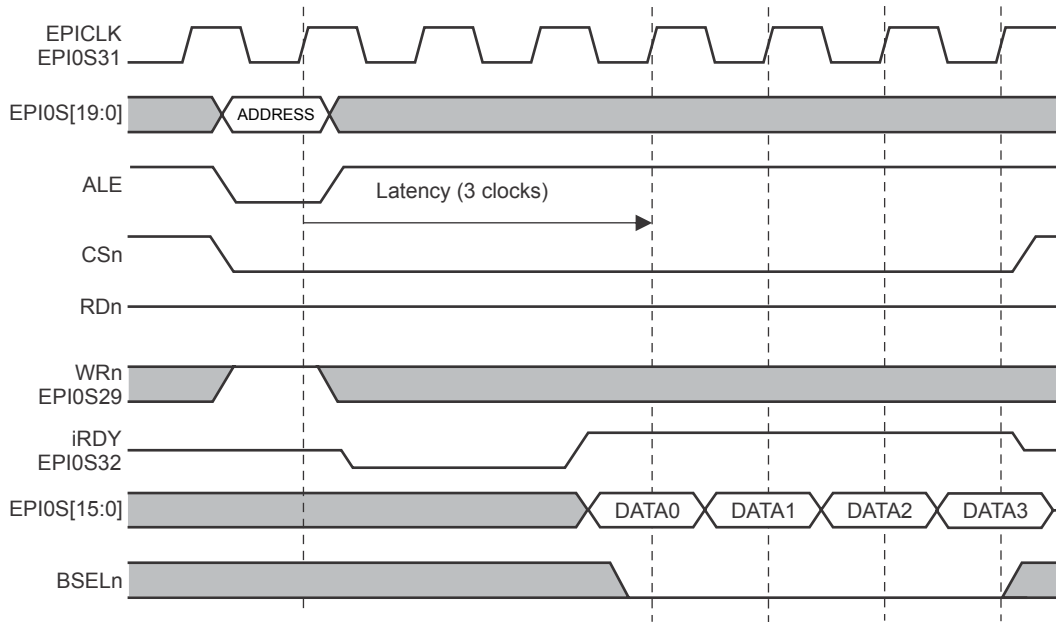
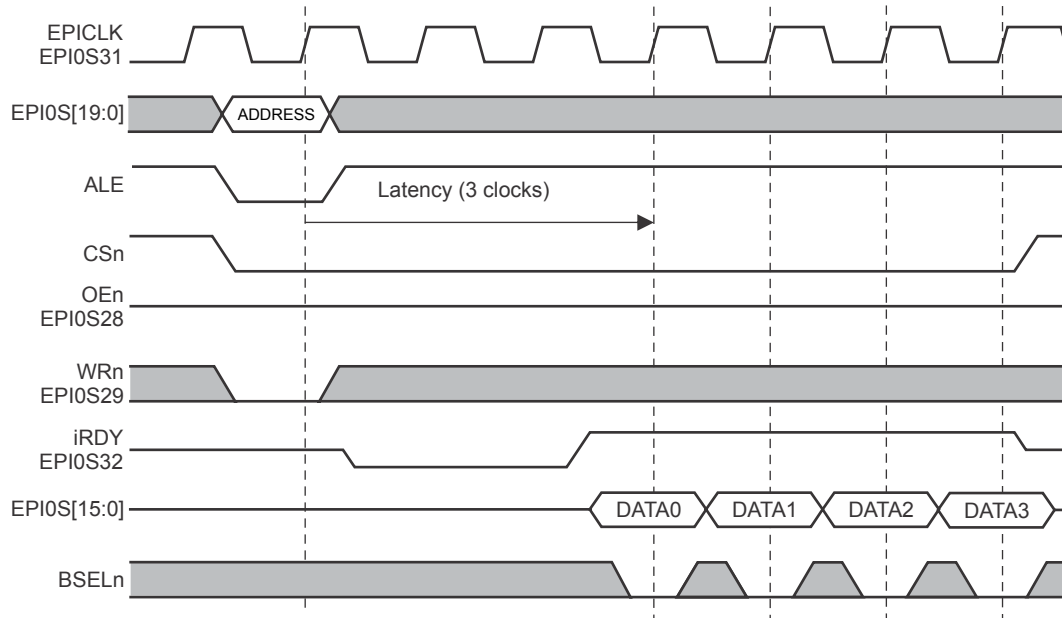

Figure 11-8. PSRAM Burst Write



Note that if a read or write transfer attempts to begin during a refresh event, the transfer is held off by the assertion of the iRDY pin by the memory to the EPI module. Figure 11-9 on page 848 and Figure 11-10 on page 849 depict the delay in data transfer during a refresh collision.

Figure 11-9. Read Delay During Refresh Event

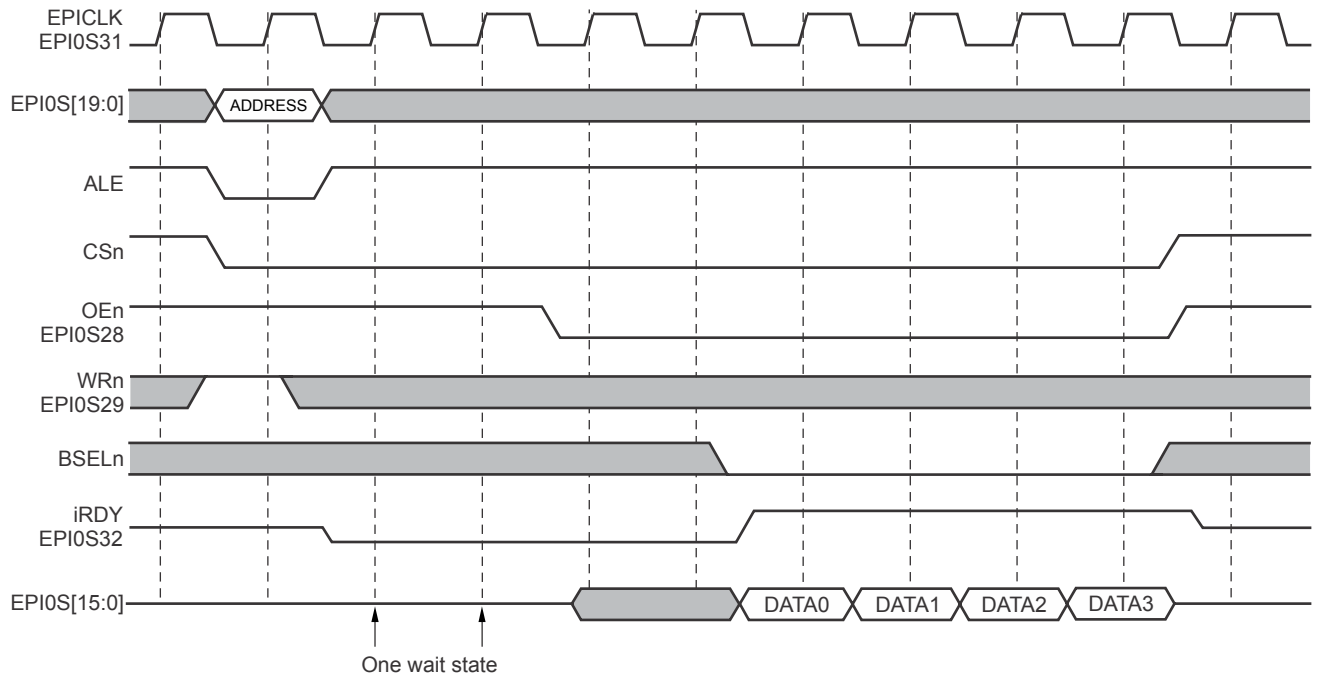
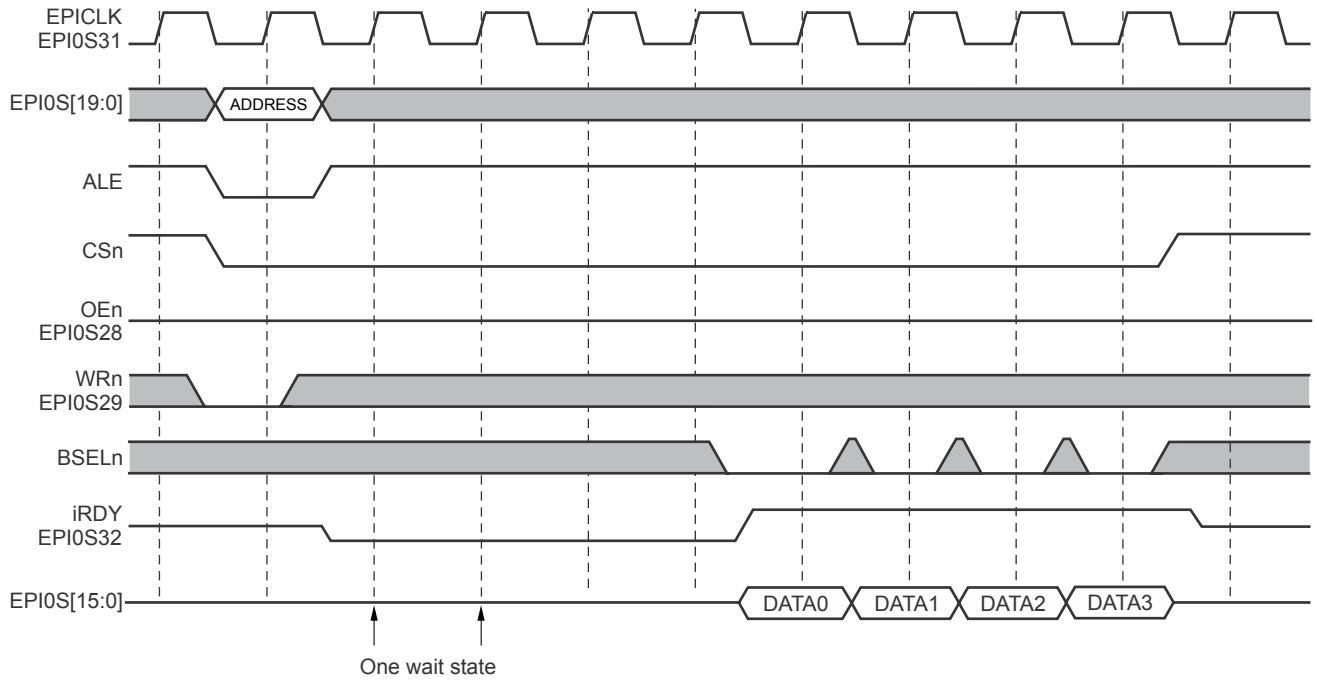
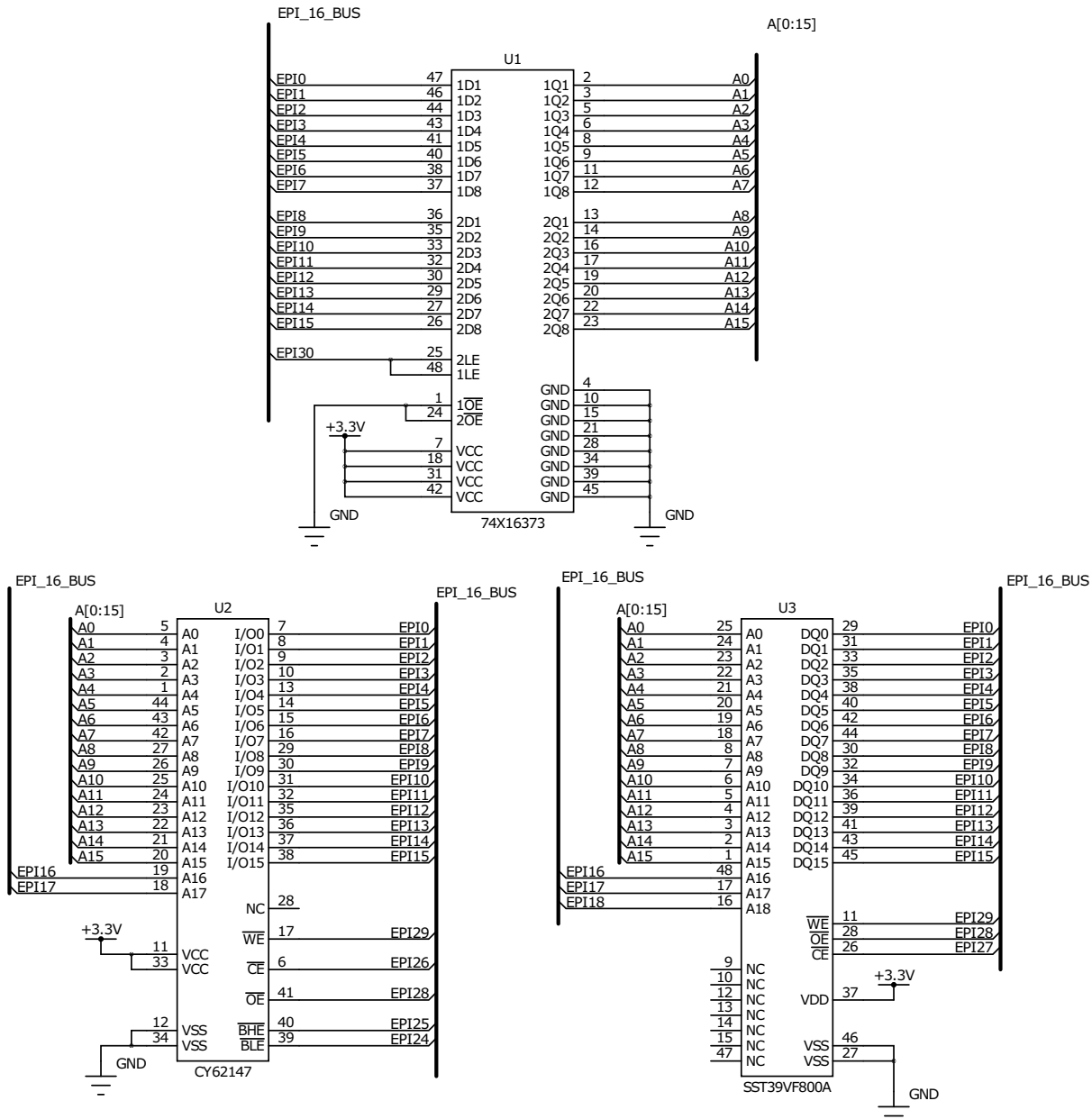

Figure 11-10. Write Delay During Refresh Event

11.4.3.3 Host Bus 16-bit Muxed Interface

Figure 11-11 on page 850 shows how to connect the EPI signals to a 16-bit SRAM and a 16-bit Flash memory with muxed address and memory using byte selects and dual chip selects with ALE. This schematic is just an example of how to connect the signals; timing and loading have not been analyzed. In addition, not all bypass capacitors are shown.

Figure 11-11. Example Schematic for Muxed Host-Bus 16 Mode



11.4.3.4 Speed of Transactions

The COUNT0 field in the **EPIBAUD** register must be configured to set the main transaction rate based on what the slave device can support (including wiring considerations). The main control transitions are normally 1/2 the baud rate (COUNT0 = 1) because the EPI block forces data versus control to change on alternating clocks. When using dual chip selects, each chip select can access the bus using differing baud rates by setting the CSBAUD bit in the **EPIHBnCFG2** register. In this case, the COUNT0 field controls the CS0n transactions, and the COUNT1 field controls the CS1n transactions. When using quad chip select mode, the COUNT0 bit field of the **EPIBAUD2** register

controls the baud rate of CS2n and the COUNT1 bit field is programmed to control the baud rate of CS3n.

Additionally, the Host-Bus mode provides read and write wait states for the data portion to support different classes of device. These wait states stretch the data period (hold the rising edge of data strobe) and may be used in all four sub-modes. The wait states are set using the WRWS and RDWS bits in the **EPI Host-Bus n Configuration (EPIHBnCFGn)** register. The WRWS and RDWS bits are enhanced with more precision by WRWSM and RDWSM bits in the **EPIHBnTIMEn** registers. Note none of the wait state configuration bits can be set concurrently with the BURST bit in the same **EPIHBnCFGn** register. See Table 11-11 on page 851 for programming information.

Table 11-11. Data Phase Wait State Programming

RDWS or WRWS Encoding in EPIHBnCFGn Register	RDWSM or WRWSM Encoding in EPIHBnTIMEn Registers	Data Phase Wait States
0x0	1	1 EPI clocks
0x0	0	2 EPI clocks
0x1	1	3 EPI clocks
0x1	0	4 EPI clocks
0x2	1	5 EPI clocks
0x2	0	6 EPI clocks
0x3	1	7 EPI clocks
0x3	0	8 EPI clocks

The CAPWIDTH bit in **EPIHBnTIMEn** registers controls the delay between Host-Bus transfers. When the CSBAUD bit is set and multi-chip selects have been configured in the **EPIHBnCFG2** registers, delay takes an additional clock cycle to adjust the clock rate of different chip selects.

Word read and write transactions can be enhanced through the enabling of the BURST bit in the **EPIHB16CFGn** registers.

11.4.3.5 Sub-Modes of Host Bus 8/16

The EPI controller supports four variants of the Host-Bus model using 8 or 16 bits of data in all four cases. The four sub-modes are selected using the MODE bits in the **EPIHBnCFG** register, and are:

1. Address and data are muxed. This scheme is used by many 8051 devices, some Microchip PIC parts, and some ATmega parts. When used for standard SRAMs, a latch must be used between the microcontroller and the SRAM. This sub-mode is provided for compatibility with existing devices that support data transfers without a latch (that is, CPLDs). In general, the de-muxed sub-mode should normally be used. The ALE configuration should be used in this mode, as all Host-Bus accesses have an address phase followed by a data phase. The ALE indicates to an external latch to capture the address then hold until the data phase. The ALE configuration is controlled by configuring the CSCFG and CSCFGEXT field to be 0x0 in the **EPIHBnCFG2** register. The ALE can be enhanced to access two or four external devices with four separate CSn signals. By configuring the CSCFG field to be 0x3 and the CSCFGEXT bit to be 0 in the **EPIHBnCFG2** register, EPI0S30 functions as ALE, EPI0S27 functions as CS1n, and EPI0S26 functions as CS0n. When the CSCFG field is set to 0x0 and the CSCFGEXT bit is set to 1 in the **EPIHBnCFG2** register, EPI0S30 functions as ALE, EPI0S33 functions as CS3n, EPI0S34 functions as CS2n, EPI0S27 functions as CS1n, and EPI0S26 functions as CS0n. The CSn is best used for Host-Bus unmuxed mode, in which EPI address and data pins are separate. The CSn indicates when the address and data phases of a read or write access are occurring.

2. Address and data are separate with 8 or 16 bits of data and up to 20 bits of address (1 MB). This scheme is used by more modern 8051 devices, as well as some PIC and ATmega parts. This mode is generally used with SRAMs in continuous read modes, many EEPROMs, and many NOR Flash memory devices. Note that there is no hardware command write support for Flash memory devices; this mode should only be used for Flash memory devices programmed at manufacturing time. If a Flash memory device must be written and does not support a direct programming model, the command mechanism must be performed in software. The CSn configuration should be used in this mode. The CSn signal indicates when the address and data phases of a read or write access is occurring. The CSn configuration is controlled by configuring the `CSCFG` field to be 0x1 and the `CSCFGEXT` bit to be 0 in the **EPIHBnCFG2** register.
3. Continuous read mode where address and data are separate. This read sub-mode is used by some SRAMs and can read more quickly by only changing the address (and not using RDn/OEn strobing). In this sub-mode, reads are performed by keeping the read mode selected (output enable is asserted) and then changing the address pins. The data pins are changed by the SRAM after the address pins change. For example, to read data from address 0x100 and then 0x101, the EPI controller asserts the output-enable signal and then configures the address pins to 0x100; the EPI controller then captures what is on the data pins and increments A0 to 1 (so the address is now 0x101); the EPI controller then captures what is on the data pins. Note that this mode consumes higher power because the SRAM must continuously drive the data pins. This mode is not practical in HB16 mode for normal SRAMs because there are generally not enough address bits available. Writes are not permitted in this mode.
4. FIFO mode uses 8 or 16 bits of data, removes ALE and address pins and optionally adds external XFIFO FULL/EMPTY flag inputs. This scheme is used by many devices, such as radios, communication devices (including USB2 devices), and some FPGA configurations (FIFO through block RAM). This sub-mode provides the data side of the normal Host-Bus interface, but is paced by the FIFO control signals. It is important to consider that the XFIFO FULL/EMPTY control signals may stall the interface and could have an impact on blocking read latency from the processor or μ DMA. Note that the EPI FIFO can only be used in asynchronous mode.

For the three modes above (1, 2, 4) that the Host-Bus 16 mode supports, byte select signals can be optionally implemented by setting the `BSEL` bit in the **EPIHB16CFG** register.

Note: Byte accesses should not be attempted if the `BSEL` bit has not been enabled in Host-Bus 16 Mode.

See “External Peripheral Interface (EPI)” on page 1977 for timing details for the Host-Bus mode.

11.4.3.6 Bus Operation

Bus operation is the same in Host-Bus 8 and Host-Bus 16 modes and is asynchronous. Timing diagrams show both ALE and CSn operation. The optional HB16 byte select signals have the same timing as the address signals. If wait states are required in the bus access, they can be inserted during the data phase of the access using the `WRWS` and `RDWS` bits in the **EPIHBnCFG2** register. Each wait state adds 2 EPI clock cycles to the duration of the WRn or RDn strobe. During idle cycles, the address and muxed address data signals maintain the state of the last cycle.

Figure 11-12 on page 853 shows a basic Host-Bus read cycle. Figure 11-13 on page 853 shows a basic Host-Bus write cycle. Both of these figures show address and data signals in the non-multiplexed mode (`MODE` field is 0x1 in the **EPIHBnCFG** register).

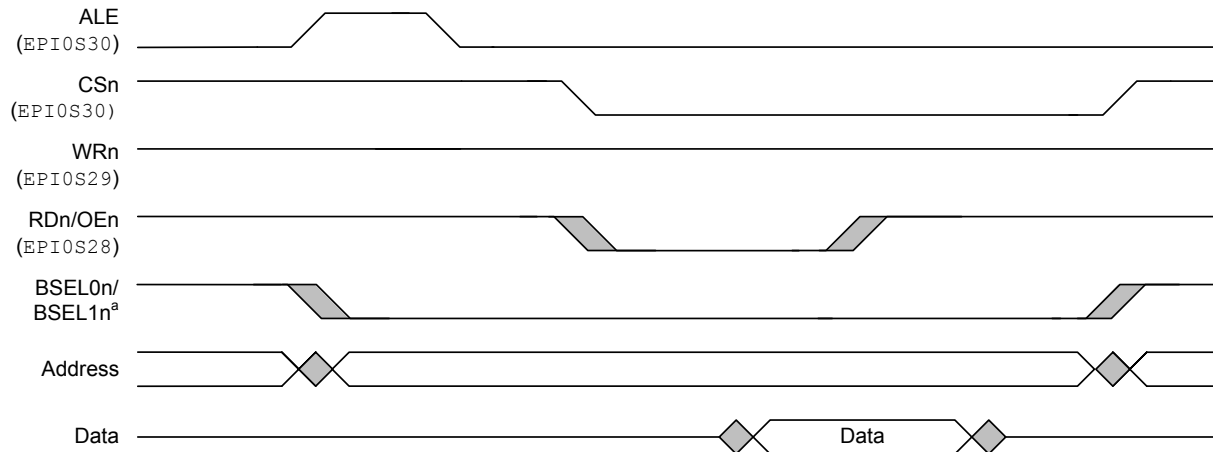
Figure 11-12. Host-Bus Read Cycle, MODE = 0x1, WRHIGH = 0, RDHIGH = 0

^a BSEL0n and BSEL1n are available in Host-Bus 16 mode only.

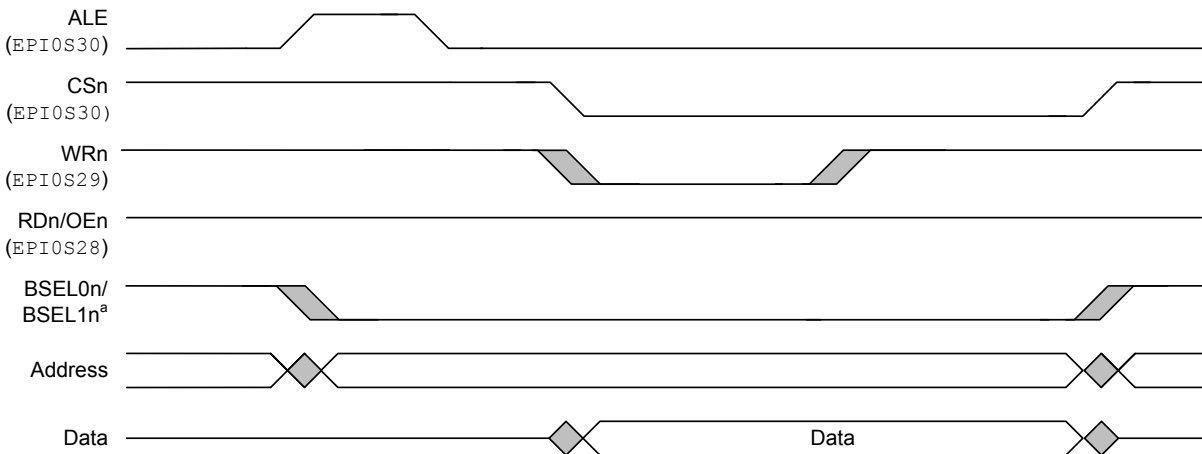
Figure 11-13. Host-Bus Write Cycle, MODE = 0x1, WRHIGH = 0, RDHIGH = 0

^a BSEL0n and BSEL1n are available in Host-Bus 16 mode only.

Figure 11-14 on page 854 shows a write cycle with the address and data signals multiplexed (MODE field is 0x0 in the **EPIHBnCFG** register). A read cycle would look similar, with the RDn strobe being asserted along with CSn and data being latched on the rising edge of RDn.

Figure 11-14. Host-Bus Write Cycle with Multiplexed Address and Data, MODE = 0x0, WRHIGH = 0, RDHIGH = 0

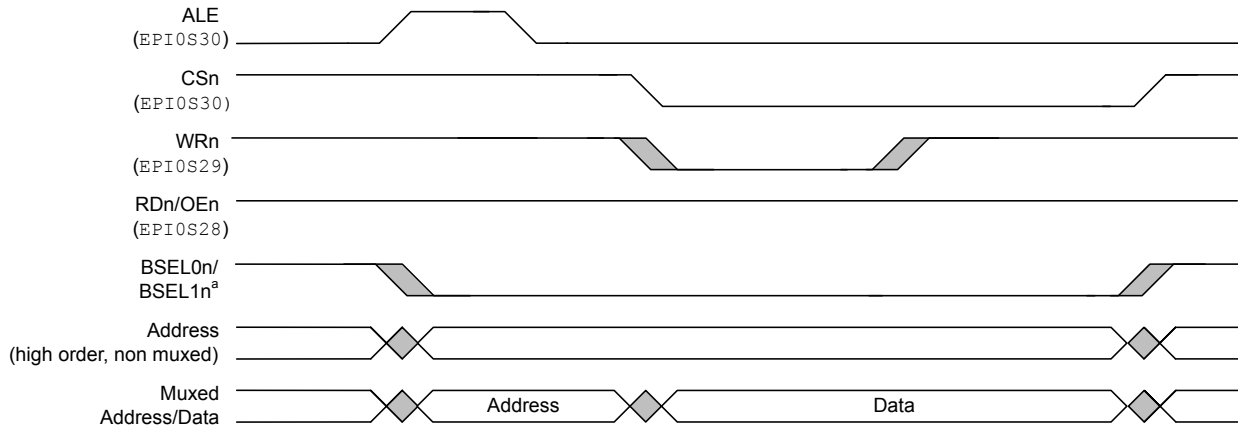

^a BSEL0n and BSEL1n are available in Host-Bus 16 mode only.

When using ALE with dual CSn configuration (CSCFGEXT bit is 0 and the CSCFG field is 0x3 in the **EPIHBnCFG2** register) or quad chip select (CSCFGEXT bit is 1 and CSCSFG is 0x2), the appropriate CSn signal is asserted at the same time as ALE, as shown in Figure 11-15 on page 854.

Figure 11-15. Host-Bus Write Cycle with Multiplexed Address and Data and ALE with Dual or Quad CSn

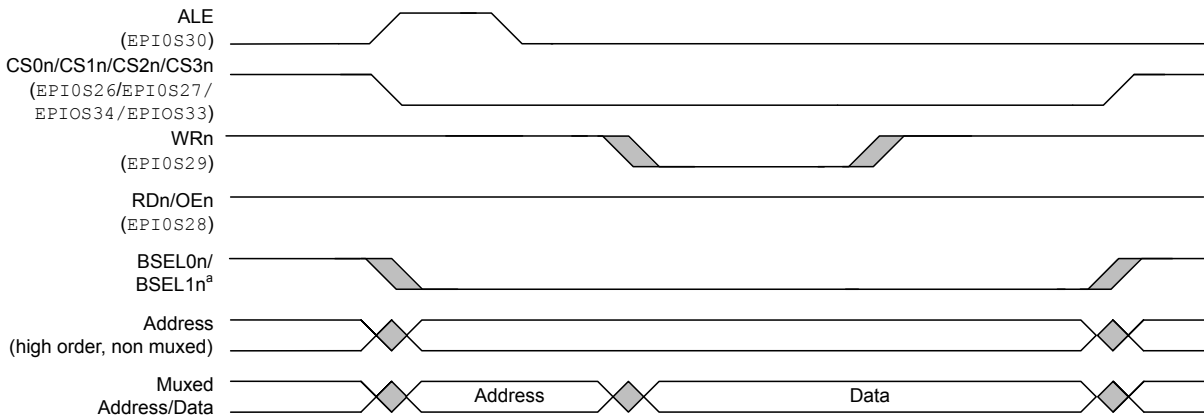

^a BSEL0n and BSEL1n are available in Host-Bus 16 mode only.

Figure 11-16 on page 854 shows continuous read mode accesses. In this mode, reads are performed by keeping the read mode selected (output enable is asserted) and then changing the address pins. The data pins are changed by the SRAM after the address pins change.

Figure 11-16. Continuous Read Mode Accesses

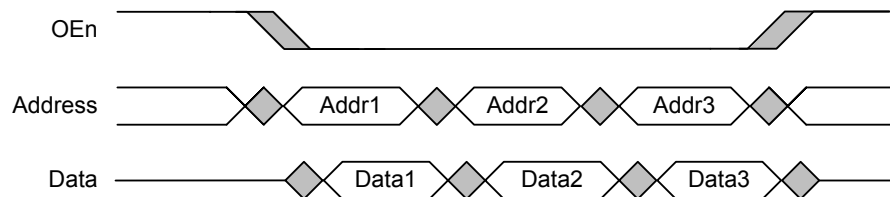

FIFO mode accesses are the same as normal read and write accesses, except that the ALE signal and address pins are not present. Two input signals can be used to indicate when the XFIFO is full or empty to gate transactions and avoid overruns and underruns. The FFULL and FEMPTY signals are synchronized and must be recognized as asserted by the microcontroller for 2 system clocks before they affect transaction status. The MAXWAIT field in the **EPIHBnCFG** register defines the maximum number of EPI clocks to wait while the FEMPTY or FFULL signal is holding off a transaction. Figure 11-17 on page 855 shows how the FEMPTY signal should respond to a write and read from the XFIFO. Figure 11-18 on page 855 shows how the FEMPTY and FFULL signals should respond to 2 writes and 1 read from an external FIFO that contains two entries.

Figure 11-17. Write Followed by Read to External FIFO

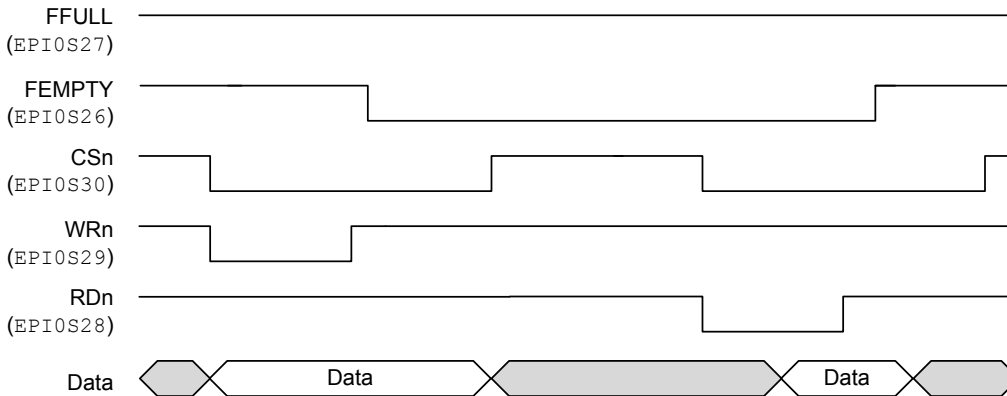
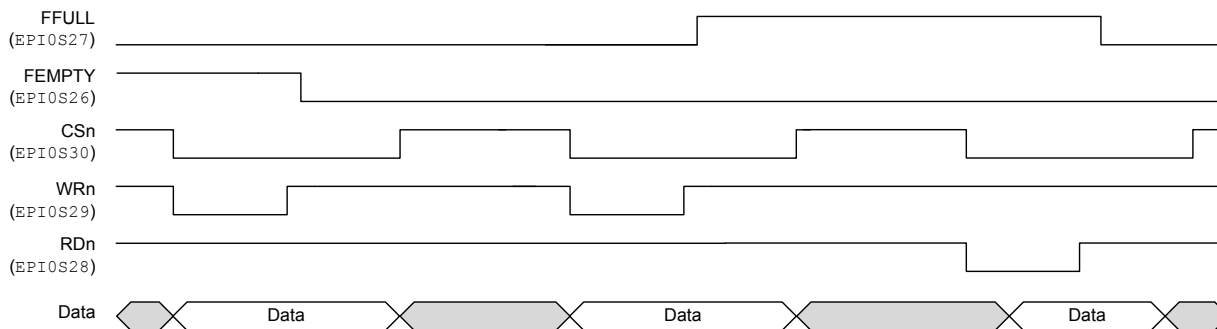

Figure 11-18. Two-Entry FIFO



11.4.4 General-Purpose Mode

The **General-Purpose Mode Configuration (EPIGPCFG)** register is used to configure the control, data, and address pins, if used. Any unused EPI controller signals can be used as GPIOs or another alternate function. The general-purpose configuration can be used for custom interfaces with FPGAs, CPLDs, and digital data acquisition and actuator control.

General-Purpose mode is designed for three general types of use:

- Extremely high-speed clocked interfaces to FPGAs and CPLDs. Three sizes of data and optional address are supported. Framing and clock-enable functions permit more optimized interfaces.
- General parallel GPIO. From 1 to 32 pins may be written or read, with the speed precisely controlled by the **EPIBAUD** register baud rate (when used with the WFIFO and/or the NBRFIFO) or by the rate of accesses from software or μ DMA. Examples of this type of use include:

- Reading 20 sensors at fixed time periods by configuring 20 pins to be inputs, configuring the `COUNT0` field in the **EPIBAUD** register to some divider, and then using non-blocking reads.
- Implementing a very wide ganged PWM/PCM with fixed frequency for driving actuators, LEDs, etc.
- General custom interfaces of any speed.

The configuration allows for choice of an output clock (free-running or gated), a framing signal (with frame size), a ready input (to stretch transactions), an address (of varying sizes), and data (of varying sizes). Additionally, provisions are made for separating data and address phases.

The interface has the following optional features:

- Use of the EPI clock output is controlled by the `CLKPIN` bit in the **EPIGPCFG** register. Unclocked uses include general-purpose I/O and asynchronous interfaces (optionally using RD and WR strobes). Clocked interfaces allow for higher speeds and are much easier to connect to FPGAs and CPLDs (which usually include input clocks).
- EPI clock, if used, may be free running or gated depending on the `CLKGATE` bit in the **EPIGPCFG** register. A free-running EPI clock requires another method for determining when data is live, such as the frame pin or RD/WR strobes. A gated clock approach uses a setup-time model in which the EPI clock controls when transactions are starting and stopping. The gated clock is held high until a new transaction is started and goes high at the end of the cycle where RD/WR/FRAME and address (and data if write) are emitted.
- Use of the RD and WR outputs is controlled by the `RW` bit in the **EPIGPCFG** register. For interfaces where the direction is known (in advance, related to frame size, or other means), these strobes are not needed. For most other interfaces, RD and WR are used so the external peripheral knows what transaction is taking place, and if any transaction is taking place.
- Separation of address/request and data phases may be used on writes using the `WR2CYC` bit in the **EPIGPCFG** register. This configuration allows the external peripheral extra time to act. Address and data phases must be separated on reads. When configured to use an address as specified by the `ASIZE` field in the **EPIGPCFG** register, the address is emitted on the with the RD strobe (first cycle) and data is expected to be returned on the next cycle (when RD is not asserted). If no address is used, then RD is asserted on the first cycle and data is captured on the second cycle (when RD is not asserted), allowing more setup time for data.

Note: When `WR2CYC = 0`, write data is valid when the WR strobe is asserted (High). When `WR2CYC = 1`, write data is valid when the WR strobe is Low after being asserted (High).

For writes, the output may be in one or two cycles. In the two-cycle case, the address (if any) is emitted on the first cycle with the WR strobe and the data is emitted on the second cycle (with WR not asserted). Although split address and write data phases are not normally needed for logic reasons, it may be useful to make read and write timings match. If 2-cycle reads or writes are used, the `RW` bit is automatically set.

- Address may be emitted (controlled by the `ASIZE` field in the **EPIGPCFG** register). The address may be up to 4 bits (16 possible values), up to 12 bits (4096 possible values), or up to 20 bits (1 M possible values). Size of address limits size of data, for example, 4 bits of address support up to 24 bits data. 4-bit address uses `EPIOS[27:24]`; 12-bit address uses `EPIOS[27:16]`; 20-bit address uses `EPIOS[27:8]`. The address signals may be used by the external peripheral as an address, code (command), or for other unrelated uses (such as a chip enable). If the chosen address/data combination does not use all of the EPI signals, the unused pins can be

used as GPIOs or for other functions. For example, when using a 4-bit address with an 8-bit data, the pins assigned to `EPI0S[23:8]` can be assigned to other functions.

- Data may be 8 bits, 16 bits, 24 bits, or 32 bits (controlled by the `DSIZE` field in the **EPIGPCFG** register). By default, the EPI controller uses data bits [7:0] when the `DSIZE` field in the **EPIGPCFG** register is 0x0; data bits [15:0] when the `DSIZE` field is 0x1; data bits [23:0] when the `DSIZE` field is 0x2; and data bits [31:0] when the `DSIZE` field is 0x3. 32-bit data cannot be used with address or EPI clock or any other signal. 24-bit data can only be used with 4-bit address or no address.
- When using the EPI controller as a GPIO interface, writes are FIFOed (up to 4 can be held at any time), and up to 32 pins are changed using the **EPIBAUD** clock rate specified by `COUNT0`. As a result, output pin control can be very precisely controlled as a function of time. By contrast, when writing to normal GPIOs, writes can only occur 8-bits at a time and take up to two clock cycles to complete. In addition, the write itself may be further delayed by the bus due to μ DMA or draining of a previous write. With both GPIO and the EPI controller, reads may be performed directly, in which case the current pin states are read back. With the EPI controller, the non-blocking interface may also be used to perform reads based on a fixed time rule via the **EPIBAUD** clock rate.

Table 11-12 on page 857 shows how the `EPI0S[31:0]` signals function while in General-Purpose mode. Notice that the address connections vary depending on the data-width restrictions of the external peripheral.

Table 11-12. EPI General-Purpose Signal Connections

EPI Signal	General-Purpose Signal (D8, A20)	General- Purpose Signal (D16, A12)	General- Purpose Signal (D24, A4)	General- Purpose Signal (D32)
EPI0S0	D0	D0	D0	D0
EPI0S1	D1	D1	D1	D1
EPI0S2	D2	D2	D2	D2
EPI0S3	D3	D3	D3	D3
EPI0S4	D4	D4	D4	D4
EPI0S5	D5	D5	D5	D5
EPI0S6	D6	D6	D6	D6
EPI0S7	D7	D7	D7	D7
EPI0S8	A0	D8	D8	D8
EPI0S9	A1	D9	D9	D9
EPI0S10	A2	D10	D10	D10
EPI0S11	A3	D11	D11	D11
EPI0S12	A4	D12	D12	D12
EPI0S13	A5	D13	D13	D13
EPI0S14	A6	D14	D14	D14
EPI0S15	A7	D15	D15	D15
EPI0S16	A8	A0 ^a	D16	D16
EPI0S17	A9	A1	D17	D17
EPI0S18	A10	A2	D18	D18
EPI0S19	A11	A3	D19	D19
EPI0S20	A12	A4	D20	D20

Table 11-12. EPI General-Purpose Signal Connections (*continued*)

EPI Signal	General-Purpose Signal (D8, A20)	General- Purpose Signal (D16, A12)	General- Purpose Signal (D24, A4)	General- Purpose Signal (D32)
EPI0S21	A13	A5	D21	D21
EPI0S22	A14	A6	D22	D22
EPI0S23	A15	A7	D23	D23
EPI0S24	A16	A8	A0 ^b	D24
EPI0S25	A17	A9	A1	D25
EPI0S26	A18	A10	A2	D26
EPI0S27	A19	A11	A3	D27
EPI0S28	WR	WR	WR	D28
EPI0S29	RD	RD	RD	D29
EPI0S30	Frame	Frame	Frame	D30
EPI0S31	Clock	Clock	Clock	D31

a. In this mode, half-word accesses are used. AO is the LSB of the address and is equivalent to the system A1 address.

b. In this mode, word accesses are used. AO is the LSB of the address and is equivalent to the system A2 address.

11.4.4.1 Bus Operation

A basic access is 1 EPI clock for write cycles and 2 EPI clocks for read cycles. An additional EPI clock can be inserted into a write cycle by setting the `WR2CYC` bit in the `EPIGPCFG` register.

Figure 11-19. Single-Cycle Single Write Access, `FRM50=0`, `FRMCNT=0`, `WR2CYC=0`

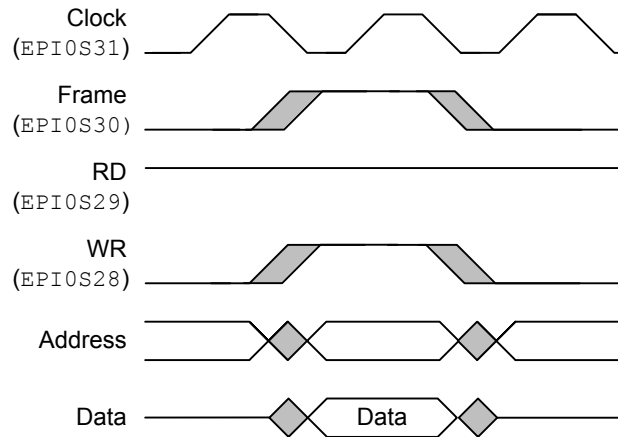
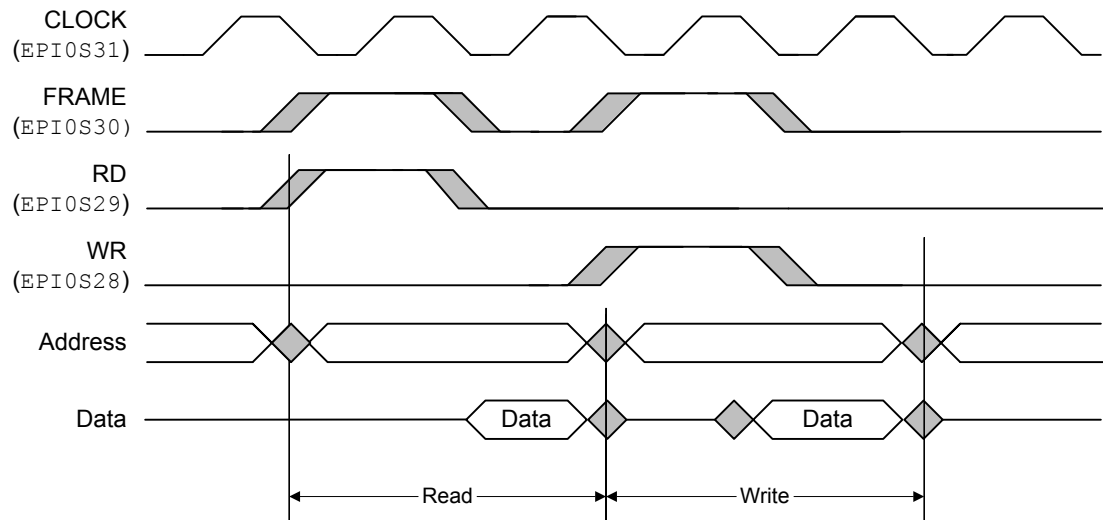
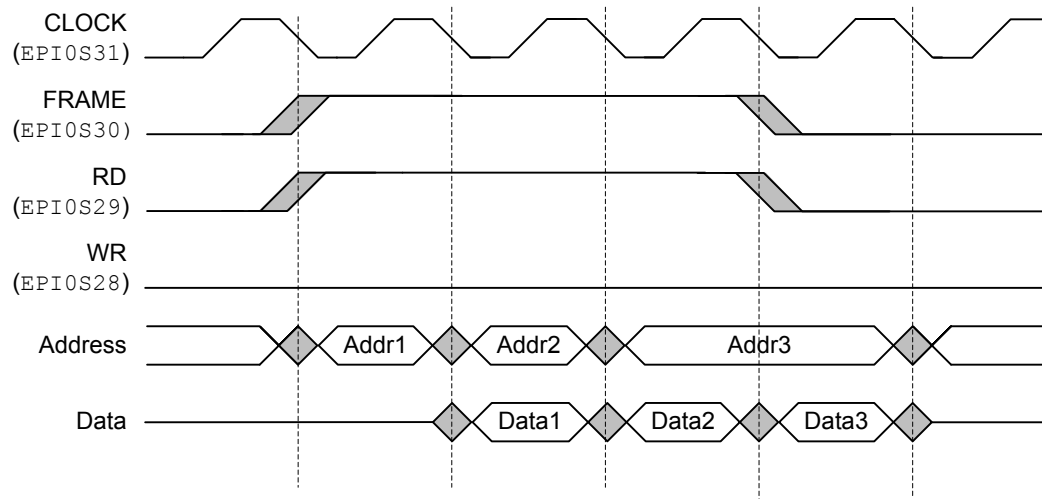
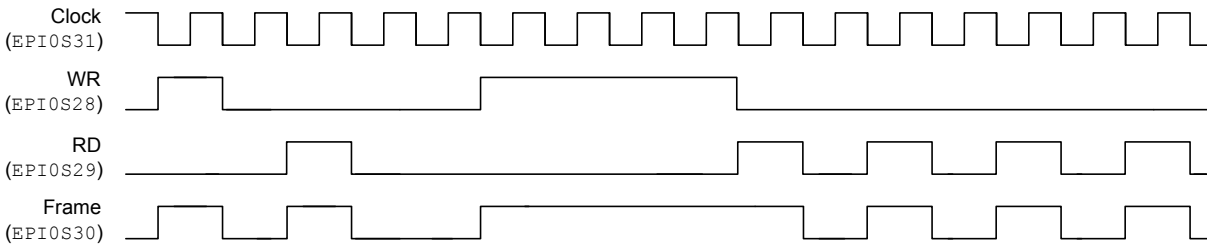

Figure 11-20. Two-Cycle Read, Write Accesses, FRM50=0, FRMCNT=0, WR2CYC=1**Figure 11-21. Read Accesses, FRM50=0, FRMCNT=0****FRAME Signal Operation**

The operation of the FRAME signal is controlled by the FRMCNT and FRM50 bits. When FRM50 is clear, the FRAME signal is high whenever the WR or RD strobe is high. When FRMCNT is clear, the FRAME signal is simply the logical OR of the WR and RD strobes so the FRAME signal is high during every read or write access, see Figure 11-22 on page 860.

Figure 11-22. FRAME Signal Operation, FRM50=0 and FRMCNT=0



If the `FRMCNT` field is `0x1`, then the `FRAME` signal pulses high during every other read or write access, see Figure 11-23 on page 860.

Figure 11-23. FRAME Signal Operation, FRM50=0 and FRMCNT=1

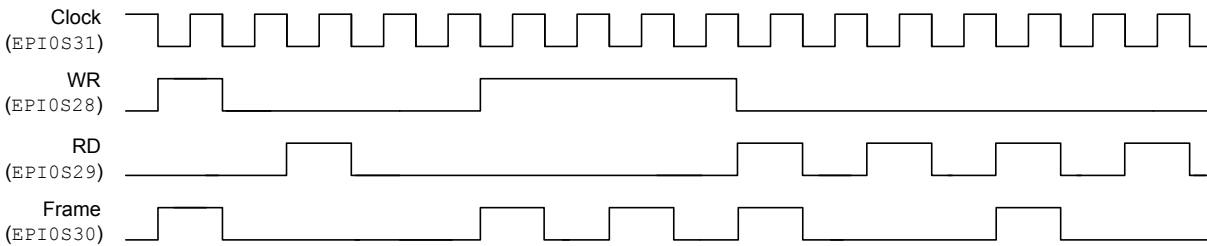

If the `FRMCNT` field is `0x2` and `FRM50` is clear, then the `FRAME` signal pulses high during every third access, and so on for every value of `FRMCNT`, see Figure 11-24 on page 860.

Figure 11-24. FRAME Signal Operation, FRM50=0 and FRMCNT=2

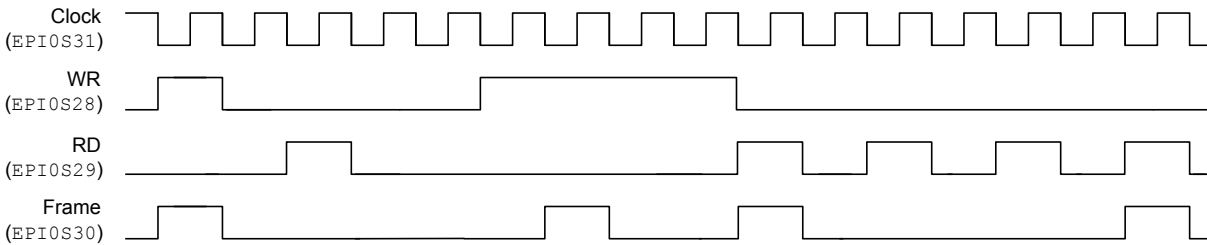

When `FRM50` is set, the `FRAME` signal transitions on the rising edge of either the `WR` or `RD` strobes. When `FRMCNT=0`, the `FRAME` signal transitions on the rising edge of `WR` or `RD` for every access, see Figure 11-25 on page 860.

Figure 11-25. FRAME Signal Operation, FRM50=1 and FRMCNT=0

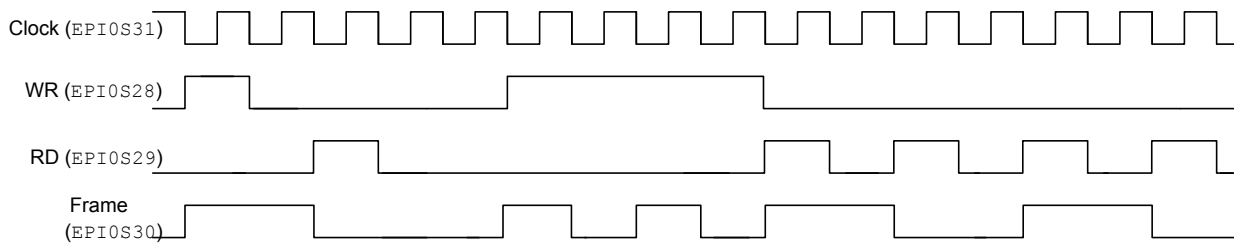

When `FRMCNT=1`, the `FRAME` signal transitions on the rising edge of the `WR` or `RD` strobes for every other access, see Figure 11-26 on page 861.

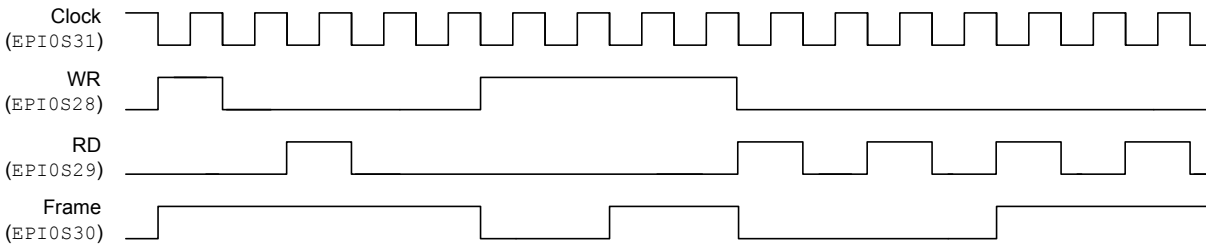
Figure 11-26. FRAME Signal Operation, FRM50=1 and FRMCNT=1

When $FRMCNT=2$, the FRAME signal transitions the rising edge of the WR or RD strobes for every third access, and so on for every value of $FRMCNT$, see Figure 11-27 on page 861.

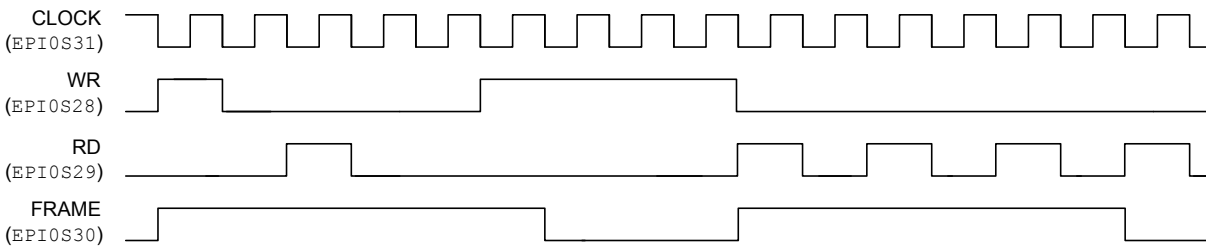
Figure 11-27. FRAME Signal Operation, FRM50=1 and FRMCNT=2

EPI Clock Operation

If the $CLKGATE$ bit in the **EPIGPCFG** register is clear, the EPI clock always toggles when General-purpose mode is enabled. If $CLKGATE$ is set, the clock is output only when a transaction is occurring, otherwise the clock is held high. If the $WR2CYC$ bit is clear, the EPI clock begins toggling 1 cycle before the WR strobe goes High. If the $WR2CYC$ bit is set, the EPI clock begins toggling when the WR strobe goes High. The clock stops toggling after the first rising edge after the WR strobe is deasserted. The RD strobe operates in the same manner as the WR strobe when the $WR2CYC$ bit is set. See Figure 11-28 on page 861 and Figure 11-29 on page 862.

Figure 11-28. EPI Clock Operation, CLKGATE=1, WR2CYC=0

Figure 11-29. EPI Clock Operation, CLKGATE=1, WR2CYC=1



11.5 Register Map

Table 11-13 on page 862 lists the EPI registers. The offset listed is a hexadecimal increment to the register's address, relative to the base address of 0x400D.0000. Note that the EPI controller clock must be enabled before the registers can be programmed (see page 393). There must be a delay of 3 system clocks after the EPI module clock is enabled before any EPI module registers are accessed.

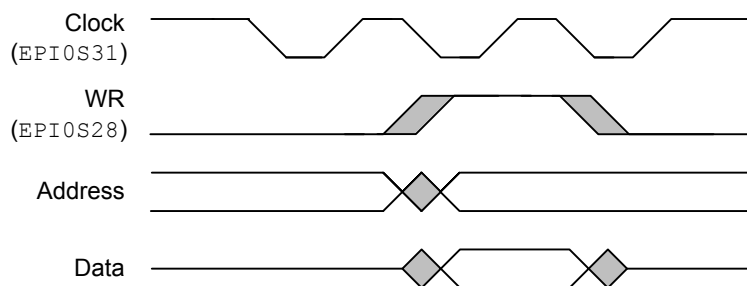
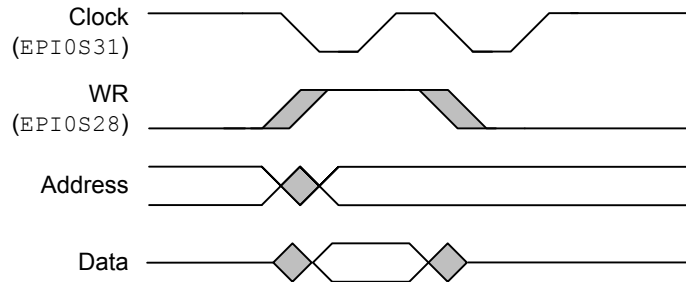
Note: A write immediately followed by a read of the same register, may not return correct data. A delay (instruction or NOP) must be inserted between the write and the read for correct operation. Read-write does not have this issue, so use of read-write for clear of error interrupt cause is not affected.

Note: For all versions of EPI, only WORD read and write accesses to registers are supported.

Table 11-13. External Peripheral Interface (EPI) Register Map

Offset	Name	Type	Reset	Description	See page
0x000	EPICFG	RW	0x0000.0000	EPI Configuration	865
0x004	EPIBAUD	RW	0x0000.0000	EPI Main Baud Rate	867
0x008	EPIBAUD2	RW	0x0000.0000	EPI Main Baud Rate	869
0x010	EPISDRAMCFG	RW	0x82EE.0000	EPI SDRAM Configuration	871
0x010	EPIHB8CFG	RW	0x0008.FF00	EPI Host-Bus 8 Configuration	873
0x010	EPIHB16CFG	RW	0x0008.FF00	EPI Host-Bus 16 Configuration	878
0x010	EPIGPCFG	RW	0x0000.0000	EPI General-Purpose Configuration	884
0x014	EPIHB8CFG2	RW	0x0008.0000	EPI Host-Bus 8 Configuration 2	887
0x014	EPIHB16CFG2	RW	0x0008.0000	EPI Host-Bus 16 Configuration 2	893
0x01C	EPIADDRMAP	RW	0x0000.0000	EPI Address Map	900
0x020	EPIRSIZE0	RW	0x0000.0003	EPI Read Size 0	903
0x024	EPIRADDR0	RW	0x0000.0000	EPI Read Address 0	904
0x028	EPIRPSTD0	RW	0x0000.0000	EPI Non-Blocking Read Data 0	905
0x030	EPIRSIZE1	RW	0x0000.0003	EPI Read Size 1	903

Table 11-13. External Peripheral Interface (EPI) Register Map (continued)

Offset	Name	Type	Reset	Description	See page
0x034	EPIRADDR1	RW	0x0000.0000	EPI Read Address 1	904
0x038	EPIRSTD1	RW	0x0000.0000	EPI Non-Blocking Read Data 1	905
0x060	EPISTAT	RO	0x0000.0000	EPI Status	907
0x06C	EPIRFIFOCNT	RO	-	EPI Read FIFO Count	909
0x070	EPIREADFIFO0	RO	-	EPI Read FIFO	910
0x074	EPIREADFIFO1	RO	-	EPI Read FIFO Alias 1	910
0x078	EPIREADFIFO2	RO	-	EPI Read FIFO Alias 2	910
0x07C	EPIREADFIFO3	RO	-	EPI Read FIFO Alias 3	910
0x080	EPIREADFIFO4	RO	-	EPI Read FIFO Alias 4	910
0x084	EPIREADFIFO5	RO	-	EPI Read FIFO Alias 5	910
0x088	EPIREADFIFO6	RO	-	EPI Read FIFO Alias 6	910
0x08C	EPIREADFIFO7	RO	-	EPI Read FIFO Alias 7	910
0x200	EPIFIFOLVL	RW	0x0000.0033	EPI FIFO Level Selects	911
0x204	EPIWFIFOCNT	RO	0x0000.0004	EPI Write FIFO Count	913
0x208	EPIDMATXCNT	RW	0x0000.0000	EPI DMA Transmit Count	914
0x210	EPIIM	RW	0x0000.0000	EPI Interrupt Mask	915
0x214	EPIRIS	RO	0x0000.0004	EPI Raw Interrupt Status	917
0x218	EPIMIS	RO	0x0000.0000	EPI Masked Interrupt Status	919
0x21C	EPIEISC	RW1C	0x0000.0000	EPI Error and Interrupt Status and Clear	921
0x308	EPIHB8CFG3	RW	0x0008.0000	EPI Host-Bus 8 Configuration 3	923
0x308	EPIHB16CFG3	RW	0x0008.0000	EPI Host-Bus 16 Configuration 3	926
0x30C	EPIHB8CFG4	RW	0x0008.0000	EPI Host-Bus 8 Configuration 4	930
0x30C	EPIHB16CFG4	RW	0x0008.0000	EPI Host-Bus 16 Configuration 4	933
0x310	EPIHB8TIME	RW	0x0002.2000	EPI Host-Bus 8 Timing Extension	937
0x310	EPIHB16TIME	RW	0x0002.2000	EPI Host-Bus 16 Timing Extension	939
0x314	EPIHB8TIME2	RW	0x0002.2000	EPI Host-Bus 8 Timing Extension	941
0x314	EPIHB16TIME2	RW	0x0002.2000	EPI Host-Bus 16 Timing Extension	943
0x318	EPIHB8TIME3	RW	0x0002.2000	EPI Host-Bus 8 Timing Extension	945
0x318	EPIHB16TIME3	RW	0x0002.2000	EPI Host-Bus 16 Timing Extension	947
0x31C	EPIHB8TIME4	RW	0x0002.2000	EPI Host-Bus 8 Timing Extension	949
0x31C	EPIHB16TIME4	RW	0x0002.2000	EPI Host-Bus 16 Timing Extension	951
0x360	EPIHBPSRAM	RW	0x0000.0000	EPI Host-Bus PSRAM	953

11.6 Register Descriptions

This section lists and describes the EPI registers, in numerical order by address offset.

Register 1: EPI Configuration (EPICFG), offset 0x000

Important: The `MODE` field determines which configuration register is accessed for offsets 0x010 and 0x014. Any write to the `EPICFG` register resets the register contents at offsets 0x010 and 0x014.

The configuration register is used to enable the block, select a mode, and select the basic pin use (based on the mode). Note that attempting to program an undefined `MODE` field clears the `BLKEN` bit and disables the EPI controller.

EPI Configuration (EPICFG)

Base 0x400D.0000
Offset 0x000
Type RW, reset 0x0000.0000

	31	30	29	28	27	26	25	24	23	22	21	20	19	18	17	16
	reserved															
Type	RO	RO	RO	RO	RO	RO	RO	RO	RO	RO	RO	RO	RO	RO	RO	RO
Reset	0	0	0	0	0	0	0	0	0	0	0	0	0	0	0	0
	15	14	13	12	11	10	9	8	7	6	5	4	3	2	1	0
	reserved							INTDIV	reserved			BLKEN	MODE			
Type	RO	RO	RO	RO	RO	RO	RO	RW	RO	RO	RO	RW	RW	RW	RW	RW
Reset	0	0	0	0	0	0	0	0	0	0	0	0	0	0	0	0

Bit/Field	Name	Type	Reset	Description
31:9	reserved	RO	0x0000.00	Software should not rely on the value of a reserved bit. To provide compatibility with future products, the value of a reserved bit should be preserved across a read-modify-write operation.
8	INTDIV	RW	0	Integer Clock Divider Enable Value Description 0 EPIBAUD register values create formula clock divide. 1 EPIBAUD register values create integer clock divide.
7:5	reserved	RO	0x0	Software should not rely on the value of a reserved bit. To provide compatibility with future products, the value of a reserved bit should be preserved across a read-modify-write operation.
4	BLKEN	RW	0	Block Enable Value Description 0 The EPI controller is disabled. 1 The EPI controller is enabled.

Bit/Field	Name	Type	Reset	Description												
3:0	MODE	RW	0x0	Mode Select												
				<table border="1"> <thead> <tr> <th>Value</th> <th>Description</th> </tr> </thead> <tbody> <tr> <td>0x0</td> <td> General Purpose General-Purpose mode. Control, address, and data pins are configured using the EPIGPCFG and EPIGPCFG2 registers. </td> </tr> <tr> <td>0x1</td> <td> SDRAM Supports SDR SDRAM. Control, address, and data pins are configured using the EPISDRAMCFG register. </td> </tr> <tr> <td>0x2</td> <td> 8-Bit Host-Bus (HB8) Host-bus 8-bit interface (also known as the MCU interface). Control, address, and data pins are configured using the EPIHB8CFG and EPIHB8CFG2 registers. </td> </tr> <tr> <td>0x3</td> <td> 16-Bit Host-Bus (HB16) Host-bus 16-bit interface (standard SRAM). Control, address, and data pins are configured using the EPIHB16CFG and EPIHB16CFG2 registers. </td> </tr> <tr> <td>0x3-0xF</td> <td>Reserved</td> </tr> </tbody> </table>	Value	Description	0x0	General Purpose General-Purpose mode. Control, address, and data pins are configured using the EPIGPCFG and EPIGPCFG2 registers.	0x1	SDRAM Supports SDR SDRAM. Control, address, and data pins are configured using the EPISDRAMCFG register.	0x2	8-Bit Host-Bus (HB8) Host-bus 8-bit interface (also known as the MCU interface). Control, address, and data pins are configured using the EPIHB8CFG and EPIHB8CFG2 registers.	0x3	16-Bit Host-Bus (HB16) Host-bus 16-bit interface (standard SRAM). Control, address, and data pins are configured using the EPIHB16CFG and EPIHB16CFG2 registers.	0x3-0xF	Reserved
Value	Description															
0x0	General Purpose General-Purpose mode. Control, address, and data pins are configured using the EPIGPCFG and EPIGPCFG2 registers.															
0x1	SDRAM Supports SDR SDRAM. Control, address, and data pins are configured using the EPISDRAMCFG register.															
0x2	8-Bit Host-Bus (HB8) Host-bus 8-bit interface (also known as the MCU interface). Control, address, and data pins are configured using the EPIHB8CFG and EPIHB8CFG2 registers.															
0x3	16-Bit Host-Bus (HB16) Host-bus 16-bit interface (standard SRAM). Control, address, and data pins are configured using the EPIHB16CFG and EPIHB16CFG2 registers.															
0x3-0xF	Reserved															

Register 2: EPI Main Baud Rate (EPIBAUD), offset 0x004

The system clock is used internally to the EPI Controller. The baud rate counter can be used to divide the system clock down to control the speed on the external interface. If the mode selected emits an external EPI clock, this register defines the EPI clock emitted. If the mode selected does not use an EPI clock, this register controls the speed of changes on the external interface. Care must be taken to program this register properly so that the speed of the external bus corresponds to the speed of the external peripheral and puts acceptable current load on the pins. `COUNT0` is the bit field used in all modes except in HB8 and HB16 modes with dual chip selects and quad chip selects when different baud rates are selected, see page 887 and page 893. If different baud rates are used, `COUNT0` is associated with the address range specified by `CS0n` and `COUNT1` is associated with the address range specified by `CS1`. The **EPIBAUD2** register configures the baud rates for `CS2n` and `CS3n`.

The `COUNTn` field is not a straight divider or count. The EPI Clock on `EPI0S31` is related to the `COUNTn` field and the system clock as follows:

If `COUNTn = 0`,

$$EPIClockFreq = SystemClockFreq$$

otherwise:

$$EPIClockFreq = \frac{SystemClockFreq}{\left(\left\lfloor \frac{COUNTn}{2} \right\rfloor + 1\right) \times 2}$$

where the symbol around `COUNTn/2` is the floor operator, meaning the largest integer less than or equal to `COUNTn/2`.

So, for example, a `COUNTn` of 0x0001 results in a clock rate of $\frac{1}{2}$ (system clock); a `COUNTn` of 0x0002 or 0x0003 results in a clock rate of $\frac{1}{4}$ (system clock).

The baud rate counter can also be configured as an integer divide by enabling `INTDIV` in the **EPICFG** register. When enabled, `COUNTn` of 0x0000 or 0x0001 results in a clock rate equal to system clock. `COUNTn` of 0x0002 results in a clock rate of $\frac{1}{2}$ (system clock). `COUNTn` of 0x0003 results in a clock rate of $\frac{1}{3}$ (system clock).

EPI Main Baud Rate (EPIBAUD)

Base 0x400D.0000

Offset 0x004

Type RW, reset 0x0000.0000

	31	30	29	28	27	26	25	24	23	22	21	20	19	18	17	16
	COUNT1															
Type	RW	RW	RW	RW	RW	RW	RW	RW	RW	RW	RW	RW	RW	RW	RW	RW
Reset	0	0	0	0	0	0	0	0	0	0	0	0	0	0	0	0
	15	14	13	12	11	10	9	8	7	6	5	4	3	2	1	0
	COUNT0															
Type	RW	RW	RW	RW	RW	RW	RW	RW	RW	RW	RW	RW	RW	RW	RW	RW
Reset	0	0	0	0	0	0	0	0	0	0	0	0	0	0	0	0

Bit/Field	Name	Type	Reset	Description
31:16	COUNT1	RW	0x0000	<p>Baud Rate Counter 1</p> <p>This bit field is only valid with multiple chip selects which are enabled when the <code>CSCFG</code> field is 0x2 or 0x3 or the <code>CSCFGEXT</code> field is set to 1, with <code>CSCFG</code> field as 0x1 or 0x2 and the <code>CSBAUD</code> bit is set in the EPIHBnCFG2 register.</p> <p>This bit field contains a counter used to divide the system clock by the count.</p> <p>A count of 0 means the system clock is used as is.</p>
15:0	COUNT0	RW	0x0000	<p>Baud Rate Counter 0</p> <p>This bit field contains a counter used to divide the system clock by the count.</p> <p>A count of 0 means the system clock is used as is.</p>

Register 3: EPI Main Baud Rate (EPIBAUD2), offset 0x008

The system clock is used internally to the EPI Controller. The baud rate counter can be used to divide the system clock down to control the speed on the external interface. If the mode selected emits an external EPI clock, this register defines the EPI clock emitted. If the mode selected does not use an EPI clock, this register controls the speed of changes on the external interface. Care must be taken to program this register properly so that the speed of the external bus corresponds to the speed of the external peripheral and puts acceptable current load on the pins. COUNT0 and COUNT1 are used in quad chip select mode when different baud rates are selected, page 887 or page 893. If different baud rates are used, COUNT0 is associated with the address range specified by CS2n and COUNT1 is associated with the address range specified by CS3n.

The COUNTn field is not a straight divider or count. The EPI Clock on EPI0S31 is related to the COUNTn field and the system clock as follows:

If COUNTn = 0,

$$EPIClockFreq = SystemClockFreq$$

otherwise:

$$EPIClockFreq = \frac{SystemClockFreq}{\left(\left\lfloor \frac{COUNTn}{2} \right\rfloor + 1\right) \times 2}$$

where the symbol around COUNTn/2 is the floor operator, meaning the largest integer less than or equal to COUNTn/2.

So, for example, a COUNTn of 0x0001 results in a clock rate of 1/2(system clock); a COUNTn of 0x0002 or 0x0003 results in a clock rate of 1/4(system clock).

EPI Main Baud Rate (EPIBAUD2)

Base 0x400D.0000
Offset 0x008
Type RW, reset 0x0000.0000

	31	30	29	28	27	26	25	24	23	22	21	20	19	18	17	16
	COUNT1															
Type	RW	RW	RW	RW	RW	RW	RW	RW	RW	RW	RW	RW	RW	RW	RW	RW
Reset	0	0	0	0	0	0	0	0	0	0	0	0	0	0	0	0
	15	14	13	12	11	10	9	8	7	6	5	4	3	2	1	0
	COUNT0															
Type	RW	RW	RW	RW	RW	RW	RW	RW	RW	RW	RW	RW	RW	RW	RW	RW
Reset	0	0	0	0	0	0	0	0	0	0	0	0	0	0	0	0

Bit/Field	Name	Type	Reset	Description
31:16	COUNT1	RW	0x0000	CS3n Baud Rate Counter 1 This bit field contains a counter used to divide the system clock by the count. A count of 0 means the system clock is unchanged. This bit field is only valid when quad chip selects are enabled by setting the CSCFGEXT bit to 1 and the CSCFG field to 0x1 or 0x2. In addition, the CSBAUD bit must be set in the EPIHBnCFG2 register.

Bit/Field	Name	Type	Reset	Description
15:0	COUNT0	RW	0x0000	<p>CS2n Baud Rate Counter 0</p> <p>This bit field contains a counter used to divide the system clock by the count.</p> <p>A count of 0 means the system clock is unchanged.</p> <p>This bit field is only valid when quad chip selects are enabled by setting the <code>CSCFGEXT</code> to 1 and the <code>CSCFG</code> field to 0x1 or 0x2. In addition, the <code>CSBAUD</code> bit must be set in the EPIHBnCFG2 register.</p>

Register 4: EPI SDRAM Configuration (EPISDRAMCFG), offset 0x010

Important: The `MODE` field in the `EPICFG` register determines which configuration register is accessed for offsets 0x010 and 0x014.

To access `EPISDRAMCFG`, the `MODE` field must be 0x1.

The SDRAM Configuration register is used to specify several parameters for the SDRAM controller. Note that this register is reset when the `MODE` field in the `EPICFG` register is changed. If another mode is selected and the SDRAM mode is selected again, the values must be reinitialized.

The SDRAM interface is designed to interface to x16 SDR SDRAMs of 64 MHz or higher, with the address and data pins overlapped (wire ORed on the board). See Table 11-3 on page 831 for pin assignments.

EPI SDRAM Configuration (EPISDRAMCFG)

Base 0x400D.0000

Offset 0x010

Type RW, reset 0x82EE.0000

	31	30	29	28	27	26	25	24	23	22	21	20	19	18	17	16
	FREQ		reserved			RFSH										
Type	RW	RW	RO	RO	RO	RW	RW	RW	RW	RW	RW	RW	RW	RW	RW	RW
Reset	1	0	0	0	0	0	1	0	1	1	1	0	1	1	1	0
	15	14	13	12	11	10	9	8	7	6	5	4	3	2	1	0
	reserved						SLEEP	reserved							SIZE	
Type	RO	RO	RO	RO	RO	RO	RW	RO	RO	RO	RO	RO	RO	RO	RW	RW
Reset	0	0	0	0	0	0	0	0	0	0	0	0	0	0	0	0

Bit/Field	Name	Type	Reset	Description										
31:30	FREQ	RW	0x2	<p>EPI Frequency Range</p> <p>This field configures the frequency range used for delay references by internal counters. This EPI frequency is the system frequency with the divider programmed by the <code>COUNT0</code> bit in the <code>EPICBAUDn</code> register bit. This field affects the power up, precharge, and auto refresh delays. This field does not affect the refresh counting, which is configured separately using the <code>RFSH</code> field (and is based on system clock rate and number of rows per bank). The ranges are:</p> <table border="1"> <thead> <tr> <th>Value</th> <th>Description</th> </tr> </thead> <tbody> <tr> <td>0x0</td> <td>0 - 15 MHz</td> </tr> <tr> <td>0x1</td> <td>15 - 30 MHz</td> </tr> <tr> <td>0x2</td> <td>30 - 50 MHz</td> </tr> <tr> <td>0x3</td> <td>50 - 100 MHz</td> </tr> </tbody> </table>	Value	Description	0x0	0 - 15 MHz	0x1	15 - 30 MHz	0x2	30 - 50 MHz	0x3	50 - 100 MHz
Value	Description													
0x0	0 - 15 MHz													
0x1	15 - 30 MHz													
0x2	30 - 50 MHz													
0x3	50 - 100 MHz													
29:27	reserved	RO	0x0	Software should not rely on the value of a reserved bit. To provide compatibility with future products, the value of a reserved bit should be preserved across a read-modify-write operation.										
26:16	RFSH	RW	0x2EE	<p>Refresh Counter</p> <p>This field contains the refresh counter in EPI clocks. The reset value of 0x2EE provides a refresh period of 64 ms when using a 50 MHz EPI clock.</p>										

Bit/Field	Name	Type	Reset	Description
15:10	reserved	RO	0x0	Software should not rely on the value of a reserved bit. To provide compatibility with future products, the value of a reserved bit should be preserved across a read-modify-write operation.
9	SLEEP	RW	0	Sleep Mode Value Description 0 No effect. 1 The SDRAM is put into low power state, but is self-refreshed.
8:2	reserved	RO	0	Software should not rely on the value of a reserved bit. To provide compatibility with future products, the value of a reserved bit should be preserved across a read-modify-write operation.
1:0	SIZE	RW	0x0	Size of SDRAM The value of this field affects address pins and behavior. Value Description 0x0 64 megabits (8MB) 0x1 128 megabits (16MB) 0x2 256 megabits (32MB) 0x3 512 megabits (64MB)

Register 5: EPI Host-Bus 8 Configuration (EPIHB8CFG), offset 0x010

Important: The `MODE` field in the `EPICFG` register determines which configuration register is accessed for offsets 0x010 and 0x014.

To access `EPIHB8CFG`, the `MODE` field must be 0x2.

The Host Bus 8 Configuration register is activated when the HB8 mode is selected. The HB8 mode supports muxed address/data (overlay of lower 8 address and all 8 data pins), separate address/data, and address-less FIFO mode. Note that this register is reset when the `MODE` field in the `EPICFG` register is changed. If another mode is selected and the HB8 mode is selected again, the values must be reinitialized.

This mode is intended to support SRAMs, Flash memory (read), FIFOs, CPLDs/FPGAs, and devices with an MCU/HostBus slave or 8-bit FIFO interface support.

Refer to Table 11-8 on page 839 for information on signal configuration controlled by this register and the `EPIHB8CFG2` register.

If less address pins are required, the corresponding `AFSEL` bit (page 778) should not be enabled so the EPI controller does not drive those pins, and they are available as standard GPIOs.

EPI Host-Bus 8 Mode can be configured to use one to four chip selects with and without the use of ALE. If an alternative to chip selects are required, a chip enable can be handled in one of three ways:

1. Manually control via GPIOs.
2. Associate one or more upper address pins to CE. Because CE is normally CEn, lower addresses are not used. For example, if pins `EPI0S27` and `EPI0S26` are used for Device 1 and 0 respectively, then address 0x6800.0000 accesses Device 0 (Device 1 has its CEn high), and 0x6400.0000 accesses Device 1 (Device 0 has its CEn high). The pull-up behavior on the corresponding GPIOs must be properly configured to ensure that the pins are disabled when the interface is not in use.
3. With certain SRAMs, the ALE can be used as CEn because the address remains stable after the ALE strobe. The subsequent `WRn` or `RDn` signals write or read when ALE is low thus providing CEn functionality.

EPI Host-Bus 8 Configuration (EPIHB8CFG)

Base 0x400D.0000

Offset 0x010

Type RW, reset 0x0008.FF00

	31	30	29	28	27	26	25	24	23	22	21	20	19	18	17	16
	CLKGATE	CLKGATEI	CLKINV	RDYEN	IRDYINV	reserved			XFFEN	XFEEN	WRHIGH	RDHIGH	ALEHIGH	reserved		
Type	RW	RW	RW	RW	RW	RO	RO	RO	RW	RW	RW	RW	RW	RO	RO	RO
Reset	0	0	0	0	0	0	0	0	0	0	0	0	1	0	0	0
	15	14	13	12	11	10	9	8	7	6	5	4	3	2	1	0
	MAXWAIT					WRWS				RDWS		reserved		MODE		
Type	RW	RW	RW	RW	RW	RW	RW	RW	RW	RW	RW	RW	RO	RO	RW	RW
Reset	1	1	1	1	1	1	1	1	0	0	0	0	0	0	0	0

Bit/Field	Name	Type	Reset	Description
31	CLKGATE	RW	0	<p>Clock Gated</p> <p>Value Description</p> <p>0 The EPI clock is free running.</p> <p>1 The EPI clock is held low.</p> <p>Note: A software application should only set the <code>CLKGATE</code> bit when there are no pending transfers or no EPI register access has been issued.</p>
30	CLKGATEI	RW	0	<p>Clock Gated when Idle</p> <p>Value Description</p> <p>0 The EPI clock is free running.</p> <p>1 The EPI clock is output only when there is data to write or read (current transaction); otherwise the EPI clock is held low.</p> <p>Note that <code>EPIOS32</code> is an <code>iRDY</code> signal if <code>RDYEN</code> is set. <code>CLKGATEI</code> is ignored if <code>CLKPIN</code> is 0 or if the <code>COUNT0</code> field in the <code>EPIBAUD</code> register is cleared.</p>
29	CLKINV	RW	0	<p>Invert Output Clock Enable</p> <p>Value Description</p> <p>0 No effect.</p> <p>1 Invert EPI clock to ensure the rising edge is centered for outbound signal's setup and hold. Inbound signal is captured on rising edge EPI clock.</p>
28	RDYEN	RW	0	<p>Input Ready Enable</p> <p>Value Description</p> <p>0 No effect.</p> <p>1 An external ready can be used to control the continuation of the current access. If this bit is set and the <code>iRDY</code> signal (<code>EPIS032</code>) is low, the current access is stalled.</p>
27	IRDYINV	RW	0	<p>Input Ready Invert</p> <p>Value Description</p> <p>0 No effect.</p> <p>1 Invert the polarity of incoming external ready (<code>iRDY</code> signal). If this bit is set and the <code>iRDY</code> signal (<code>EPIS032</code>) is high the current access is stalled.</p>
26:24	reserved	RO	0x0	Software should not rely on the value of a reserved bit. To provide compatibility with future products, the value of a reserved bit should be preserved across a read-modify-write operation.

Bit/Field	Name	Type	Reset	Description
23	XFFEN	RW	0	External FIFO FULL Enable Value Description 0 No effect. 1 An external FIFO full signal can be used to control write cycles. If this bit is set and the FFULL full signal is high, XFIFO writes are stalled.
22	XFEEN	RW	0	External FIFO EMPTY Enable Value Description 0 No effect. 1 An external FIFO empty signal can be used to control read cycles. If this bit is set and the FEMPTY signal is high, XFIFO reads are stalled.
21	WRHIGH	RW	0	WRITE Strobe Polarity Value Description 0 The WRITE strobe for CS0n is WRn (active Low). 1 The WRITE strobe for CS0n is WR (active High).
20	RDHIGH	RW	0	READ Strobe Polarity Value Description 0 The READ strobe for CS0n is RDn (active Low). 1 The READ strobe for CS0n is RD (active High).
19	ALEHIGH	RW	1	ALE Strobe Polarity Value Description 0 The address latch strobe for CS0n accesses is ALEn (active Low). 1 The address latch strobe for CS0n accesses is ALE (active High).
18:16	reserved	RO	0x0	Software should not rely on the value of a reserved bit. To provide compatibility with future products, the value of a reserved bit should be preserved across a read-modify-write operation.
15:8	MAXWAIT	RW	0xFF	Maximum Wait This field defines the maximum number of external clocks to wait while an external FIFO ready signal is holding off a transaction (FFULL and FEMPTY). When the MAXWAIT value is reached the ERRRIS interrupt status bit is set in the EPIRIS register. When this field is clear, the transaction can be held off forever without a system interrupt. Note: When the MODE field is configured to be 0x2 and the BLKEN bit is set in the EPICFG register, enabling HB8 mode, this field defaults to 0xFF.

Bit/Field	Name	Type	Reset	Description
7:6	WRWS	RW	0x0	<p>Write Wait States</p> <p>This field adds wait states to the data phase of CS0n (the address phase is not affected). The effect is to delay the rising edge of WRn (or the falling edge of WR). Each wait state adds 2 EPI clock cycles to the access time. The WRWSM bit in the EPIHB8TIME register can decrease the number of wait states by 1 EPI clock cycle for greater granularity. This field is not applicable in BURST mode.</p> <p>Value Description</p> <p>0x0 Active WRn is 2 EPI clocks.</p> <p>0x1 Active WRn is 4 EPI clocks.</p> <p>0x2 Active WRn is 6 EPI clocks.</p> <p>0x3 Active WRn is 8 EPI clocks.</p> <p>This field is used in conjunction with the EPIBAUD register.</p>
5:4	RDWS	RW	0x0	<p>Read Wait States</p> <p>This field adds wait states to the data phase of CS0n (the address phase is not affected).</p> <p>The effect is to delay the rising edge of RDn/Oen (or the falling edge of RD). Each wait state adds 2 EPI clock cycles to the access time. The RDWSM bit in the EPIHB8TIME register can decrease the number of wait states by 1 EPI clock cycle for greater granularity. This field is not applicable in BURST mode.</p> <p>Value Description</p> <p>0x0 Active RDn is 2 EPI clocks.</p> <p>0x1 Active RDn is 4 EPI clocks.</p> <p>0x2 Active RDn is 6 EPI clocks.</p> <p>0x3 Active RDn is 8 EPI clocks.</p> <p>This field is used in conjunction with the EPIBAUD register</p>
3:2	reserved	RO	0x0	<p>Software should not rely on the value of a reserved bit. To provide compatibility with future products, the value of a reserved bit should be preserved across a read-modify-write operation.</p>

Bit/Field	Name	Type	Reset	Description
1:0	MODE	RW	0x0	<p>Host Bus Sub-Mode</p> <p>This field determines which of four Host Bus 8 sub-modes to use. Sub-mode use is determined by the connected external peripheral. See Table 11-8 on page 839 for information on how this bit field affects the operation of the EPI signals. When used with multiple chip select option and the CSBAUD bit is set to 1 in the EPIHB8CFG2 register, this configuration is for CS0n. If the multiple chip select option is enabled and CSBAUD is clear, all chip-selects use the MODE encoding programmed in this register.</p> <p>Value Description</p> <p>0x0 ADMUX – AD[7:0] Data and Address are muxed.</p> <p>0x1 ADNONMUX – D[7:0] Data and address are separate.</p> <p>0x2 Continuous Read - D[7:0] This mode is the same as ADNONMUX, but uses address switch for multiple reads instead of OEn strobing.</p> <p>0x3 XFIFO – D[7:0] This mode adds XFIFO controls with sense of XFIFO full and XFIFO empty. This mode uses no address or ALE. Note that the XFIFO can only be used in asynchronous mode.</p>

Register 6: EPI Host-Bus 16 Configuration (EPIHB16CFG), offset 0x010

Important: The `MODE` field in the `EPICFG` register determines which configuration register is accessed for offsets 0x010 and 0x014.

To access `EPIHB16CFG`, the `MODE` field must be 0x3.

The Host Bus 16 sub-configuration register is activated when the HB16 mode is selected. The HB16 mode supports muxed address/data (overlay of lower 16 address and all 16 data pins), separated address/data, and address-less FIFO mode. Note that this register is reset when the `MODE` field in the `EPICFG` register is changed. If another mode is selected and the HB16 mode is selected again, the values must be reinitialized.

This mode is intended to support SRAMs, Flash memory (read), FIFOs, and CPLDs/FPGAs, and devices with an MCU/HostBus slave or 16-bit FIFO interface support.

Refer to Table 11-9 on page 841 for information on signal configuration controlled by this register and the `EPIHB16CFG2` register.

If less address pins are required, the corresponding `AFSEL` bit (page 778) should not be enabled so the EPI controller does not drive those pins, and they are available as standard GPIOs.

EPI Host-Bus 16 Mode can be configured to use one to four chip selects with and without the use of ALE. If an alternative to chip selects are required, a chip enable can be handled in one of three ways:

1. Manually control via GPIOs.
2. Associate one or more upper address pins to CE. Because CE is normally CEn, lower addresses are not used. For example, if pins `EPI0S27` and `EPI0S26` are used for Device 1 and 0 respectively, then address 0x6800.0000 accesses Device 0 (Device 1 has its CEn high), and 0x6400.0000 accesses Device 1 (Device 0 has its CEn high). The pull-up behavior on the corresponding GPIOs must be properly configured to ensure that the pins are disabled when the interface is not in use.
3. With certain SRAMs, the ALE can be used as CEn because the address remains stable after the ALE strobe. The subsequent `WRn` or `RDn` signals write or read when ALE is low thus providing CEn functionality.

EPI Host-Bus 16 Configuration (EPIHB16CFG)

Base 0x400D.0000

Offset 0x010

Type RW, reset 0x0008.FF00

	31	30	29	28	27	26	25	24	23	22	21	20	19	18	17	16
	CLKGATE	CLKGATEI	CLKINV	RDYEN	IRDYINV	reserved			XFFEN	XFEEN	WRHIGH	RDHIGH	ALEHIGH	WRCRE	RDCRE	BURST
Type	RW	RW	RW	RW	RW	RO	RO	RO	RW	RW	RW	RW	RW	RW	RW	RW
Reset	0	0	0	0	0	0	0	0	0	0	0	0	1	0	0	0
	15	14	13	12	11	10	9	8	7	6	5	4	3	2	1	0
	MAXWAIT								WRWS		RDWS		reserved	BSEL	MODE	
Type	RW	RW	RW	RW	RW	RW	RW	RW	RW	RW	RW	RW	RO	RW	RW	RW
Reset	1	1	1	1	1	1	1	1	0	0	0	0	0	0	0	0

Bit/Field	Name	Type	Reset	Description
31	CLKGATE	RW	0	<p>Clock Gated</p> <p>Value Description</p> <p>0 The EPI clock is free running.</p> <p>1 The EPI clock is held low.</p> <p>Note: A software application should only set the CLKGATE bit when there are no pending transfers or no EPI register access has been issued.</p>
30	CLKGATEI	RW	0	<p>Clock Gated Idle</p> <p>Value Description</p> <p>0 The EPI clock is free running.</p> <p>1 The EPI clock is output only when there is data to write or read (current transaction); otherwise the EPI clock is held low.</p> <p>Note that EPIS032 is an iRDY signal if RDYEN is set. CLKGATEI is ignored if CLKPIN is 0 or if the COUNT0 field in the EPIBAUD register is cleared.</p>
29	CLKINV	RW	0	<p>Invert Output Clock Enable</p> <p>Note: If operating in asynchronous mode, CLKINV must be 0.</p> <p>Value Description</p> <p>0 No effect.</p> <p>1 Invert EPI clock to ensure the rising edge is centered for outbound signal's setup and hold. Inbound signal is captured on rising edge EPI clock.</p>
28	RDYEN	RW	0	<p>Input Ready Enable</p> <p>Value Description</p> <p>0 No effect.</p> <p>1 An external ready (iRDY) can be used to control the continuation of the current access. If this bit is set and the iRDY signal (EPIS032) is low, the current access is stalled.</p>
27	IRDYINV	RW	0	<p>Input Ready Invert</p> <p>Value Description</p> <p>0 No effect.</p> <p>1 Invert polarity of incoming external ready. If this bit is set and the iRDY signal (EPIS032) is high the current access is stalled.</p>
26:24	reserved	RO	0x00	Software should not rely on the value of a reserved bit. To provide compatibility with future products, the value of a reserved bit should be preserved across a read-modify-write operation.

Bit/Field	Name	Type	Reset	Description
23	XFFEN	RW	0	<p>External FIFO FULL Enable</p> <p>Value Description</p> <p>0 No effect.</p> <p>1 An external FIFO full signal can be used to control write cycles. If this bit is set and the FFULL signal is high, XFIFO writes are stalled.</p>
22	XFEEN	RW	0	<p>External FIFO EMPTY Enable</p> <p>Value Description</p> <p>0 No effect.</p> <p>1 An external FIFO empty signal can be used to control read cycles. If this bit is set and the FEMPTY signal is high, XFIFO reads are stalled.</p>
21	WRHIGH	RW	0	<p>WRITE Strobe Polarity</p> <p>Value Description</p> <p>0 The WRITE strobe for CS0n is WRn (active Low).</p> <p>1 The WRITE strobe for CS0n is WR (active High).</p>
20	RDHIGH	RW	0	<p>READ Strobe Polarity</p> <p>Value Description</p> <p>0 The READ strobe for CS0n is RDn (active Low).</p> <p>1 The READ strobe for CS0n is RD (active High).</p>
19	ALEHIGH	RW	1	<p>ALE Strobe Polarity</p> <p>Value Description</p> <p>0 The address latch strobe for CS0n is ALEn (active Low).</p> <p>1 The address latch strobe for CS0n is ALE (active High).</p>
18	WRCRE	RW	0	<p>PSRAM Configuration Register Write</p> <p>Used for PSRAM configuration registers.</p> <p>With <code>WRCRE</code> set, the next transaction by the EPI will be a write of the <code>CR</code> bit field in the EPIHBPSRAM register to the configuration register (CR) of the PSRAM. The <code>WRCRE</code> bit will self clear once the write-enabled CRE access is complete.</p> <p>Value Description</p> <p>0 No Action.</p> <p>1 Start CRE write transaction for CS0n.</p>

Bit/Field	Name	Type	Reset	Description
17	RDCRE	RW	0	<p>PSRAM Configuration Register Read</p> <p>Enables read of PSRAM configuration registers.</p> <p>With the <code>RDCRE</code> set, the next access is a read of the PSRAM's Configuration Register (CR). This bit self clears once the read-enabled CRE access is complete. The address for the CRE access is located at EPIHBPSRAM[19:18]. The read data is returned on EPIHBPSRAM[15:0].</p> <p>Value Description</p> <p>0 No Action.</p> <p>1 Start CRE read transaction for CS0n.</p>
16	BURST	RW	0	<p>Burst Mode</p> <p>Burst mode must be used with an ALE-enabled interface. Burst mode must be used with ADMUX, which is configured by the <code>MODE</code> field in the EPIHB16CFG register.</p> <p>Note: Burst mode is optimized for word-length accesses.</p> <p>Value Description</p> <p>0 Burst mode is disabled.</p> <p>1 Burst mode is enabled for CS0n or single chip access.</p>
15:8	MAXWAIT	RW	0xFF	<p>Maximum Wait</p> <p>This field defines the maximum number of external clocks to wait while an external FIFO ready signal is holding off a transaction (FFULL and FEMPTY).</p> <p>When this field is clear, the transaction can be held off forever without a system interrupt.</p> <p>Note: When the <code>MODE</code> field is configured to be 0x3 and the BLKEN bit is set in the EPICFG register, enabling HB16 mode, this field defaults to 0xFF.</p>
7:6	WRWS	RW	0x0	<p>Write Wait States</p> <p>This field adds wait states to the data phase of CS0n (the address phase is not affected). The effect is to delay the rising edge of WRn (or the falling edge of WR). Each wait state adds 2 EPI clock cycles to the access time. The <code>WRWSM</code> bit EPIHB16TIME register can decrease the number of wait states by 1 EPI clock cycle for greater granularity. This field is not applicable in BURST mode.</p> <p>Value Description</p> <p>0x0 Active WRn is 2 EPI clocks.</p> <p>0x1 Active WRn is 4 EPI clocks.</p> <p>0x2 Active WRn is 6 EPI clocks.</p> <p>0x3 Active WRn is 8 EPI clocks.</p> <p>This field is used in conjunction with the EPIBAUD register.</p>

Bit/Field	Name	Type	Reset	Description
5:4	RDWS	RW	0x0	<p>Read Wait States</p> <p>This field adds wait states to the data phase of CS0n (the address phase is not affected).</p> <p>The effect is to delay the rising edge of RDn/Oen (or the falling edge of RD). Each wait state adds 2 EPI clock cycles to the access time. The RDWSM bit in the EPIHB16TIME register can decrease the number of wait states by 1 EPI clock cycle for greater granularity. This field is not applicable in BURST mode.</p> <p>Value Description</p> <p>0x0 Active RDn is 2 EPI clocks.</p> <p>0x1 Active RDn is 4 EPI clocks.</p> <p>0x2 Active RDn is 6 EPI clocks.</p> <p>0x3 Active RDn is 8 EPI clocks.</p> <p>This field is used in conjunction with the EPIBAUD register</p>
3	reserved	RO	0	<p>Software should not rely on the value of a reserved bit. To provide compatibility with future products, the value of a reserved bit should be preserved across a read-modify-write operation.</p>
2	BSEL	RW	0	<p>Byte Select Configuration</p> <p>This bit enables byte select operation.</p> <p>Value Description</p> <p>0 No Byte Selects Data is read and written as 16 bits.</p> <p>1 Enable Byte Selects Two EPI signals function as byte select signals to allow 8-bit transfers. See Table 11-9 on page 841 for details on which EPI signals are used.</p> <p>Note: If BSEL = 0, byte accesses cannot be executed.</p>

Bit/Field	Name	Type	Reset	Description
1:0	MODE	RW	0x0	<p>Host Bus Sub-Mode</p> <p>This field determines which of three Host Bus 16 sub-modes to use. Sub-mode use is determined by the connected external peripheral. See Table 11-9 on page 841 for information on how this bit field affects the operation of the EPI signals. When used with multiple chip select option and the CSBAUD bit is set to 1 in the EPIHB16CFG2 register, this configuration is for CS0n. If the multiple chip select option is enabled and CSBAUD is clear, all chip-selects use the MODE encoding programmed in this register.</p> <p>Value Description</p> <p>0x0 ADMUX – AD[15:0] Data and Address are muxed.</p> <p>0x1 ADNONMUX – D[15:0] Data and address are separate. This mode is not practical in HB16 mode for normal peripherals because there are generally not enough address bits available.</p> <p>0x2 Continuous Read - D[15:0] This mode is the same as ADNONMUX, but uses address switch for multiple reads instead of OEn strobing. This mode is not practical in HB16 mode for normal SRAMs because there are generally not enough address bits available.</p> <p>0x3 XFIFO – D[15:0] This mode adds XFIFO controls with sense of XFIFO full and XFIFO empty. This mode uses no address or ALE. Note that the XFIFO can only be used in asynchronous mode.</p>

Register 7: EPI General-Purpose Configuration (EPIGPCFG), offset 0x010

Important: The `MODE` field in the **EPICFG** register determines which configuration register is accessed for offsets 0x010 and 0x014.

To access **EPIGPCFG**, the `MODE` field must be 0x0.

The General-Purpose configuration register is used to configure the control, data, and address pins. This mode can be used for custom interfaces with FPGAs, CPLDs, and for digital data acquisition and actuator control. Note that this register is reset when the `MODE` field in the **EPICFG** register is changed. If another mode is selected and the General-purpose mode is selected again, the register the values must be reinitialized.

This mode is designed for 3 general types of use:

- Extremely high-speed clocked interfaces to FPGAs and CPLDs, with 3 sizes of data and optional address. Framing and clock-enable permit more optimized interfaces.
- General parallel GPIO. From 1 to 32 pins may be written or read, with the speed precisely controlled by the baud rate in the **EPIBAUD** register (when used with the NBRFIFO and/or the WFIFO) or by rate of accesses from software or μ DMA.
- General custom interfaces of any speed.

The configuration allows for choice of an output clock (free running or gated), a framing signal (with frame size), a ready input (to stretch transactions), read and write strobes, address of varying sizes, and data of varying sizes. Additionally, provisions are made for splitting address and data phases on the external interface.

EPI General-Purpose Configuration (EPIGPCFG)

Base 0x400D.0000
 Offset 0x010
 Type RW, reset 0x0000.0000

	31	30	29	28	27	26	25	24	23	22	21	20	19	18	17	16
	CLKPIN	CLKGATE	reserved			FRM50	FRMCNT				reserved		WR2CYC	reserved		
Type	RW	RW	RO	RO	RO	RW	RW	RW	RW	RW	RO	RO	RW	RO	RO	RO
Reset	0	0	0	0	0	0	0	0	0	0	0	0	0	0	0	0
	15	14	13	12	11	10	9	8	7	6	5	4	3	2	1	0
	reserved										ASIZE		reserved		DSIZE	
Type	RO	RO	RO	RO	RO	RO	RO	RO	RO	RO	RW	RW	RO	RO	RW	RW
Reset	0	0	0	0	0	0	0	0	0	0	0	0	0	0	0	0

Bit/Field	Name	Type	Reset	Description
31	CLKPIN	RW	0	Clock Pin

Value	Description
0	No clock output.
1	<code>EPI0S31</code> functions as the EPI clock output.

The EPI clock is generated from the `COUNT0` field in the **EPIBAUD** register (as is the system clock which is divided down from it).

Bit/Field	Name	Type	Reset	Description
30	CLKGATE	RW	0	<p>Clock Gated</p> <p>Value Description</p> <p>0 The EPI clock is free running.</p> <p>1 The EPI clock is output only when there is data to write or read (current transaction); otherwise the EPI clock is held low.</p> <p>CLKGATE is ignored if CLKPIN is 0 or if the COUNT0 field in the EPIBAUD register is cleared.</p>
29:27	reserved	RO	0	Software should not rely on the value of a reserved bit. To provide compatibility with future products, the value of a reserved bit should be preserved across a read-modify-write operation.
26	FRM50	RW	0	<p>50/50 Frame</p> <p>Value Description</p> <p>0 The FRAME signal is output as a single pulse, and then held low for the count.</p> <p>1 The FRAME signal is output as 50/50 duty cycle using count (see FRMCNT).</p>
25:22	FRMCNT	RW	0x0	<p>Frame Count</p> <p>This field specifies the size of the frame in EPI clocks. The frame counter is used to determine the frame size. The count is FRMCNT+1. So, a FRMCNT of 0 forms a pure transaction valid signal (held high during transactions, low otherwise).</p> <p>A FRMCNT of 0 with FRM50 set inverts the FRAME signal on each transaction. A FRMCNT of 1 means the FRAME signal is inverted every other transaction; a value of 15 means every sixteenth transaction.</p> <p>If FRM50 is set, the frame is held high for FRMCNT+1 transactions, then held low for that many transactions, and so on.</p> <p>If FRM50 is clear, the frame is pulsed high for one EPI clock and then low for FRMCNT EPI clocks.</p>
21:20	reserved	RO	0	Software should not rely on the value of a reserved bit. To provide compatibility with future products, the value of a reserved bit should be preserved across a read-modify-write operation.
19	WR2CYC	RW	0	<p>2-Cycle Writes</p> <p>Value Description</p> <p>0 Data is output on the same EPI clock cycle as the address. EPI clock begins toggling one cycle before the WR strobe goes High.</p> <p>1 Writes are two EPI clock cycles long, with address on one EPI clock cycle (with the WR strobe asserted) and data written on the following EPI clock cycle (with WR strobe deasserted). The next address (if any) is in the cycle following.</p> <p>If the WR2CYC bit is set, the EPI clock begins toggling when the WR strobe goes High.</p> <p>When this bit is set, then the RW bit is forced to be set.</p>

Bit/Field	Name	Type	Reset	Description										
18:6	reserved	RO	0	Software should not rely on the value of a reserved bit. To provide compatibility with future products, the value of a reserved bit should be preserved across a read-modify-write operation.										
5:4	ASIZE	RW	0x0	<p>Address Bus Size</p> <p>This field defines the size of the address bus. The address can be up to 4-bits wide with a 24-bit data bus, up to 12-bits wide with a 16-bit data bus, and up to 20-bits wide with an 8-bit data bus. If the full address bus is not used, use the least significant address bits. Any unused address bits can be used as GPIOs by clearing the <code>AFSEL</code> bit for the corresponding GPIOs.</p> <p>The values are:</p> <table border="1"> <thead> <tr> <th>Value</th> <th>Description</th> </tr> </thead> <tbody> <tr> <td>0x0</td> <td>No address</td> </tr> <tr> <td>0x1</td> <td>Up to 4 bits wide.</td> </tr> <tr> <td>0x2</td> <td>Up to 12 bits wide. This size cannot be used with 24-bit data.</td> </tr> <tr> <td>0x3</td> <td>Up to 20 bits wide. This size cannot be used with data sizes other than 8.</td> </tr> </tbody> </table>	Value	Description	0x0	No address	0x1	Up to 4 bits wide.	0x2	Up to 12 bits wide. This size cannot be used with 24-bit data.	0x3	Up to 20 bits wide. This size cannot be used with data sizes other than 8.
Value	Description													
0x0	No address													
0x1	Up to 4 bits wide.													
0x2	Up to 12 bits wide. This size cannot be used with 24-bit data.													
0x3	Up to 20 bits wide. This size cannot be used with data sizes other than 8.													
3:2	reserved	RO	0x0	Software should not rely on the value of a reserved bit. To provide compatibility with future products, the value of a reserved bit should be preserved across a read-modify-write operation.										
1:0	DSIZE	RW	0x0	<p>Size of Data Bus</p> <p>This field defines the size of the data bus (starting at <code>EPI0S0</code>). Subsets of these numbers can be created by clearing the <code>AFSEL</code> bit for the corresponding GPIOs. Note that size 32 may not be used with clock, frame, address, or other control.</p> <p>The values are:</p> <table border="1"> <thead> <tr> <th>Value</th> <th>Description</th> </tr> </thead> <tbody> <tr> <td>0x0</td> <td>8 Bits Wide (<code>EPI0S0</code> to <code>EPI0S7</code>)</td> </tr> <tr> <td>0x1</td> <td>16 Bits Wide (<code>EPI0S0</code> to <code>EPI0S15</code>)</td> </tr> <tr> <td>0x2</td> <td>24 Bits Wide (<code>EPI0S0</code> to <code>EPI0S23</code>)</td> </tr> <tr> <td>0x3</td> <td>32 Bits Wide (<code>EPI0S0</code> to <code>EPI0S31</code>)</td> </tr> </tbody> </table> <p>This size may not be used with an EPI clock. This value is normally used for acquisition input and actuator control as well as other general-purpose uses that require 32 bits per direction.</p>	Value	Description	0x0	8 Bits Wide (<code>EPI0S0</code> to <code>EPI0S7</code>)	0x1	16 Bits Wide (<code>EPI0S0</code> to <code>EPI0S15</code>)	0x2	24 Bits Wide (<code>EPI0S0</code> to <code>EPI0S23</code>)	0x3	32 Bits Wide (<code>EPI0S0</code> to <code>EPI0S31</code>)
Value	Description													
0x0	8 Bits Wide (<code>EPI0S0</code> to <code>EPI0S7</code>)													
0x1	16 Bits Wide (<code>EPI0S0</code> to <code>EPI0S15</code>)													
0x2	24 Bits Wide (<code>EPI0S0</code> to <code>EPI0S23</code>)													
0x3	32 Bits Wide (<code>EPI0S0</code> to <code>EPI0S31</code>)													

Register 8: EPI Host-Bus 8 Configuration 2 (EPIHB8CFG2), offset 0x014

Important: The `MODE` field in the `EPICFG` register determines which configuration register is accessed for offsets 0x010 and 0x014.

To access `EPIHB8CFG2`, the `MODE` field of the `EPICFG` register must be 0x2.

This register is used to configure operation while in Host-Bus 8 mode. Note that this register is reset when the `MODE` field in the `EPICFG` register is changed. If another mode is selected and the Host-Bus 8 mode is selected again, the values must be reinitialized.

EPI Host-Bus 8 Configuration 2 (EPIHB8CFG2)

Base 0x400D.0000

Offset 0x014

Type RW, reset 0x0008.0000

	31	30	29	28	27	26	25	24	23	22	21	20	19	18	17	16
	reserved				CSCFGEXT	CSBAUD	CSCFG		reserved		WRHIGH	RDHIGH	ALEHIGH	reserved		
Type	RO	RO	RO	RO	RW	RW	RW	RW	RO	RO	RW	RW	RW	RO	RO	RO
Reset	0	0	0	0	0	0	0	0	0	0	0	0	1	0	0	0
	15	14	13	12	11	10	9	8	7	6	5	4	3	2	1	0
	reserved								WRWS		RDWS		reserved		MODE	
Type	RO	RO	RO	RO	RO	RO	RO	RO	RW	RW	RW	RW	RO	RO	RW	RW
Reset	0	0	0	0	0	0	0	0	0	0	0	0	0	0	0	0

Bit/Field	Name	Type	Reset	Description
31:28	reserved	RO	0	Software should not rely on the value of a reserved bit. To provide compatibility with future products, the value of a reserved bit should be preserved across a read-modify-write operation.

Bit/Field	Name	Type	Reset	Description
27	CSCFGEXT	RW	0	<p>Chip Select Extended Configuration</p> <p>This field is used in conjunction with <code>CSCFG</code>, to extend the chip select options, and ALE format. The values 0x0 through 0x3 are from the <code>CSCFG</code> field. The <code>CSCFGEXT</code> bit extends the values to 0x7.</p>

Value Description

- 0 `CSCFG` bit field is used in chip select configuration.
- 1 The `CSCFG` bit field is extended with `CSCFGEXT` representing the MSB.

The possible chip select configurations when the `CSCFGEXT` bit is enabled are shown below:

Table 11-14. CSCFGEXT + CSCFG Encodings

Value	Description
0x0	<p>ALE Configuration</p> <p><code>EPI0S30</code> is used as an address latch (ALE). The ALE signal is generally used when the address and data are muxed (<code>MODE</code> field in the <code>EPIHB8CFG</code> register is 0x0). The ALE signal is used by an external latch to hold the address through the bus cycle.</p>
0x1	<p>CSn Configuration</p> <p><code>EPI0S30</code> is used as a Chip Select (CSn). When using this mode, the address and data are generally not muxed (<code>MODE</code> field in the <code>EPIHB8CFG</code> register is 0x1). However, if address and data muxing is needed, the <code>WR</code> signal (<code>EPI0S29</code>) and the <code>RD</code> signal (<code>EPI0S28</code>) can be used to latch the address when CSn is low.</p>
0x2	<p>Dual CSn Configuration</p> <p><code>EPI0S30</code> is used as CS0n and <code>EPI0S27</code> is used as CS1n. Whether CS0n or CS1n is asserted is determined by the most significant address bit for a respective external address map. This configuration can be used for a RAM bank split between 2 devices as well as when using both an external RAM and an external peripheral.</p>
0x3	<p>ALE with Dual CSn Configuration</p> <p><code>EPI0S30</code> is used as address latch (ALE), <code>EPI0S27</code> is used as CS1n, and <code>EPI0S26</code> is used as CS0n. Whether CS0n or CS1n is asserted is determined by the most significant address bit for a respective external address map.</p>
0x4	<p>ALE with Single CSn Configuration</p> <p><code>EPI0S30</code> is used as address latch (ALE) and <code>EPI0S27</code> is used as CSn.</p>
0x5	<p>Quad CSn Configuration</p> <p><code>EPI0S30</code> is used as CS0n and <code>EPI0S27</code> is used as CS1n. <code>EPI0S34</code> is used as CS2n and <code>EPI0S33</code> is used as CS3n.</p>
0x6	<p>ALE with Quad CSn Configuration</p> <p><code>EPI0S30</code> is used as ALE, <code>EPI0S26</code> is CS0n, and <code>EPI0S27</code> is used as CS1n. <code>EPI0S34</code> is used as CS2n and <code>EPI0S33</code> is used as CS3n.</p>
0x7	Reserved

Bit/Field	Name	Type	Reset	Description
26	CSBAUD	RW	0	<p>Chip Select Baud Rate and Multiple Sub-Mode Configuration enable</p> <p>This bit is only valid when the <code>CSCFGEXT + CSCFG</code> field is programmed to 0x2 or 0x3, 0x5 or 0x6. This bit configures the baud rate settings for CS0n, CS1n, CS2n, and CS3n.</p> <p>This bit must also be set to allow different sub-mode configurations on chip-selects. If this bit is clear, all chip-select sub-modes are based on the <code>MODE</code> encoding defined in the EPI8HBCFG register.</p> <p>If the <code>CSBAUD</code> bit is set in the EPIHnCFG2 register and dual- or quad-chip selects are enabled, then the individual chip selects can use different clock frequencies, wait states and strobe polarity.</p> <p>Value Description</p> <p>0 Same Baud Rate and Same Sub-Mode All CSn use the baud rate for the external bus that is defined by the <code>COUNT0</code> field in the EPIBAUD register and the sub-mode programmed in the <code>MODE</code> field of the EPIH8CFG register.</p> <p>1 Different Baud Rates CS0n uses the baud rate for the external bus that is defined by the <code>COUNT0</code> field in the EPIBAUD register. CS1n uses the baud rate defined by the <code>COUNT1</code> field in the EPIBAUD register. CS2n uses the baud rate for the external bus that is defined by the <code>COUNT0</code> field in the EPIBAUD2 register. CS3n uses the baud rate defined by the <code>COUNT1</code> field in the EPIBAUD2 register. In addition, the sub-modes for each chip select are individually programmed in their respective EPIH8CFGn registers.</p>

Bit/Field	Name	Type	Reset	Description
25:24	CSCFG	RW	0x0	<p>Chip Select Configuration</p> <p>This field controls the chip select options, including an ALE format, a single chip select, two chip selects, and an ALE combined with two chip selects. These bits are also used in combination with the CSCFGEXT bit for further configurations, including quad- chip select.</p> <p>Value Description</p> <p>0x0 ALE Configuration EPIOS30 is used as an address latch (ALE). The ALE signal is generally used when the address and data are muxed (HB8MODE field in the EPIHB8CFG register is 0x0). The ALE signal is used by an external latch to hold the address through the bus cycle.</p> <p>0x1 CSn Configuration EPIOS30 is used as a Chip Select (CSn). When using this mode, the address and data are generally not muxed (HB8MODE field in the EPIHB8CFG register is 0x1). However, if address and data muxing is needed, the WR signal (EPIOS29) and the RD signal (EPIOS28) can be used to latch the address when CSn is low.</p> <p>0x2 Dual CSn Configuration EPIOS30 is used as CS0n and EPIOS27 is used as CS1n. Whether CS0n or CS1n is asserted is determined by two methods. If only external RAM or external PER is enabled in the address map, the most significant address bit for a respective external address map controls CS0n or CS1n. If both external RAM and external PER is enabled, CS0n is mapped to PER and CS1n is mapped to RAM. This configuration can be used for a RAM bank split between 2 devices as well as when using both an external RAM and an external peripheral.</p> <p>0x3 ALE with Dual CSn Configuration EPIOS30 is used as address latch (ALE), EPIOS27 is used as CS1n, and EPIOS26 is used as CS0n. Whether CS0n or CS1n is asserted is determined by the most significant address bit for a respective external address map.</p>
23:22	reserved	RO	0x0	Software should not rely on the value of a reserved bit. To provide compatibility with future products, the value of a reserved bit should be preserved across a read-modify-write operation.
21	WRHIGH	RW	0	<p>CS1n WRITE Strobe Polarity</p> <p>This field is used if the CSBAUD bit in the EPIHB8CFG2 register is enabled.</p> <p>Value Description</p> <p>0 The WRITE strobe for CS1n accesses is WRn (active Low).</p> <p>1 The WRITE strobe for CS1n accesses is WR (active High).</p>

Bit/Field	Name	Type	Reset	Description
20	RDHIGH	RW	0	<p>CS1n READ Strobe Polarity</p> <p>This field is used if the CSBAUD bit in the EPIHB8CFG2 register is enabled.</p> <p>Value Description</p> <p>0 The READ strobe for CS1n accesses is RDn (active Low).</p> <p>1 The READ strobe for CS1n accesses is RD (active High).</p>
19	ALEHIGH	RW	1	<p>CS1n ALE Strobe Polarity</p> <p>This field is used if the CSBAUD bit in the EPIHB8CFG2 register is enabled.</p> <p>Value Description</p> <p>0 The address latch strobe for CS1n accesses is ALEn (active Low).</p> <p>1 The address latch strobe for CS1n accesses is ALE (active High).</p>
18:8	reserved	RO	0	<p>Software should not rely on the value of a reserved bit. To provide compatibility with future products, the value of a reserved bit should be preserved across a read-modify-write operation.</p>
7:6	WRWS	RW	0x0	<p>CS1n Write Wait States</p> <p>This field adds wait states to the data phase of CS1n accesses (the address phase is not affected).</p> <p>The effect is to delay the rising edge of WRn (or the falling edge of WR). Each wait state encoding adds 2 EPI clock cycles to the access time. The WRWSM bit in the EPIHB8TIME2 register can decrease the number of wait states by 1 EPI clock cycle for greater granularity.</p> <p>This field is used if the CSBAUD bit is enabled in the EPIHB8CFG2 register. This field is used in conjunction with the EPIBAUD register and is not applicable in BURST mode.</p> <p>Value Description</p> <p>0x0 Active WRn is 2 EPI clocks.</p> <p>0x1 Active WRn is 4 EPI clocks</p> <p>0x2 Active WRn is 6 EPI clocks</p> <p>0x3 Active WRn is 8 EPI clocks</p>

Bit/Field	Name	Type	Reset	Description
5:4	RDWS	RW	0x0	<p>CS1n Read Wait States</p> <p>This field adds wait states to the data phase of CS1n accesses (the address phase is not affected).</p> <p>The effect is to delay the rising edge of RDn/Oen (or the falling edge of RD). Each wait state encoding adds 2 EPI clock cycles to the access time. The RDWSM bit in the EPIHB8TIME2 register can decrease the number of states by 1 EPI clock cycle for greater granularity.</p> <p>This field is used if the CSBAUD bit is enabled in the EPIHB8CFG2 register. This field is used in conjunction with the EPIBAUD register and is not applicable in BURST mode.</p> <p>Value Description</p> <p>0x0 Active RDn is 2 EPI clocks</p> <p>0x1 Active RDn is 4 EPI clocks</p> <p>0x2 Active RDn is 6 EPI clocks</p> <p>0x3 Active RDn is 8 EPI clocks</p>
3:2	reserved	RO	0x0	<p>Software should not rely on the value of a reserved bit. To provide compatibility with future products, the value of a reserved bit should be preserved across a read-modify-write operation.</p>
1:0	MODE	RW	0x0	<p>CS1n Host Bus Sub-Mode</p> <p>This field determines which Host Bus 8 sub-mode to use for CS1n. Sub-mode use is determined by the externally connected peripheral or memory. See Table 11-8 on page 839 for information on how this bit field affects the operation of the EPI signals.</p> <p>Note: The CSBAUD bit must be set to enable this CS1n MODE field. If CSBAUD is clear, all chip-selects use the MODE configuration defined in the EPIHB8CFG register.</p> <p>Value Description</p> <p>0x0 ADMUX – AD[7:0] Data and Address are muxed.</p> <p>0x1 ADNONMUX – D[7:0] Data and address are separate.</p> <p>0x2-0x3 reserved</p>

Register 9: EPI Host-Bus 16 Configuration 2 (EPIHB16CFG2), offset 0x014

Important: The `MODE` field in the `EPICFG` register determines which configuration register is accessed for offsets 0x010 and 0x014.

To access `EPIHB16CFG2`, the `MODE` field must be 0x3.

This register is used to configure operation while in Host-Bus 16 mode. Note that this register is reset when the `MODE` field in the `EPICFG` register is changed. If another mode is selected and the Host-Bus 16 mode is selected again, the values must be reinitialized.

EPI Host-Bus 16 Configuration 2 (EPIHB16CFG2)

Base 0x400D.0000

Offset 0x014

Type RW, reset 0x0008.0000

	31	30	29	28	27	26	25	24	23	22	21	20	19	18	17	16
	reserved				CSCFGEXT	CSBAUD	CSCFG		reserved		WRHIGH	RDHIGH	ALEHIGH	WRCRE	RDCRE	BURST
Type	RO	RO	RO	RO	RW	RW	RW	RW	RO	RO	RW	RW	RW	RW	RW	RW
Reset	0	0	0	0	0	0	0	0	0	0	0	0	1	0	0	0
	15	14	13	12	11	10	9	8	7	6	5	4	3	2	1	0
	reserved								WRWS		RDWS		reserved		MODE	
Type	RO	RO	RO	RO	RO	RO	RO	RO	RW	RW	RW	RW	RO	RO	RW	RW
Reset	0	0	0	0	0	0	0	0	0	0	0	0	0	0	0	0

Bit/Field	Name	Type	Reset	Description
31:28	reserved	RO	0	Software should not rely on the value of a reserved bit. To provide compatibility with future products, the value of a reserved bit should be preserved across a read-modify-write operation.

Bit/Field	Name	Type	Reset	Description
27	CSCFGEXT	RW	0	<p>Chip Select Extended Configuration</p> <p>This field is used in conjunction with <code>CSCFG</code>, to extend the chip select options, and ALE format. The values 0x0 through 0x3 are from the <code>CSCFG</code> field. The <code>CSCFGEXT</code> bit extends the values to 0x7.</p>

Value	Description
0	<code>CSCFG</code> bit field is used in chip select configuration.
1	The <code>CSCFG</code> bit field is extended with <code>CSCFGEXT</code> representing the MSB.

The possible chip select configurations when the `CSCFGEXT` bit is enabled are shown below:

Table 11-15. CSCFGEXT + CSCFG Encodings

Value	Description
0x0	<p>ALE Configuration</p> <p><code>EPI0S30</code> is used as an address latch (ALE). The ALE signal is generally used when the address and data are muxed (<code>MODE</code> field in the <code>EPIHB16CFG</code> register is 0x0). The ALE signal is used by an external latch to hold the address through the bus cycle.</p>
0x1	<p>CSn Configuration</p> <p><code>EPI0S30</code> is used as a Chip Select (CSn). When using this mode, the address and data are generally not muxed (<code>MODE</code> field in the <code>EPIHB16CFG</code> register is 0x1). However, if address and data muxing is needed, the <code>WR</code> signal (<code>EPI0S29</code>) and the <code>RD</code> signal (<code>EPI0S28</code>) can be used to latch the address when CSn is low.</p>
0x2	<p>Dual CSn Configuration</p> <p><code>EPI0S30</code> is used as CS0n and <code>EPI0S27</code> is used as CS1n. Whether CS0n or CS1n is asserted is determined by the most significant address bit for a respective external address map. This configuration can be used for a RAM bank split between 2 devices as well as when using both an external RAM and an external peripheral.</p>
0x3	<p>ALE with Dual CSn Configuration</p> <p><code>EPI0S30</code> is used as address latch (ALE), <code>EPI0S27</code> is used as CS1n, and <code>EPI0S26</code> is used as CS0n. Whether CS0n or CS1n is asserted is determined by the most significant address bit for a respective external address map.</p>
0x4	<p>ALE with Single CSn Configuration</p> <p><code>EPI0S30</code> is used as address latch (ALE) and <code>EPI0S27</code> is used as CSn.</p>
0x5	<p>Quad CSn Configuration</p> <p><code>EPI0S30</code> is used as CS0n and <code>EPI0S27</code> is used as CS1n. <code>EPI0S34</code> is used as CS2n and <code>EPI0S33</code> is used as CS3n.</p>
0x6	<p>ALE with Quad CSn Configuration</p> <p><code>EPI0S30</code> is used as ALE, <code>EPI0S26</code> is CS0n, and <code>EPI0S27</code> is used as CS1n. <code>EPI0S34</code> is used as CS2n and <code>EPI0S33</code> is used as CS3n.</p>
0x7	Reserved

Bit/Field	Name	Type	Reset	Description
26	CSBAUD	RW	0	<p>Chip Select Baud Rate and Multiple Sub-Mode Configuration enable</p> <p>This bit is only valid when the <code>CSCFGEXT + CSCFG</code> field is programmed to 0x2 or 0x3, 0x5 or 0x6. This bit configures the baud rate settings for CS0n, CS1n, CS2n, and CS3n.</p> <p>This bit must also be set to allow different sub-mode configurations on chip-selects. If this bit is clear, all chip-select sub-modes are based on the <code>MODE</code> encoding defined in the EPI8HBCFG register.</p> <p>If the <code>CSBAUD</code> bit is set in the EPIHBnCFG2 register and dual- or quad-chip selects are enabled, then the individual chip selects can use different clock frequencies, wait states and strobe polarity.</p> <p>Value Description</p> <p>0 Same Baud Rate and Same Sub-Mode All CSn use the baud rate for the external bus that is defined by the <code>COUNT0</code> field in the EPIBAUD register and the sub-mode programmed in the <code>MODE</code> field of the EPIHB16CFG register.</p> <p>1 Different Baud Rates CS0n uses the baud rate for the external bus that is defined by the <code>COUNT0</code> field in the EPIBAUD register. CS1n uses the baud rate defined by the <code>COUNT1</code> field in the EPIBAUD register. CS2n uses the baud rate for the external bus that is defined by the <code>COUNT0</code> field in the EPIBAUD2 register. CS3n uses the baud rate defined by the <code>COUNT1</code> field in the EPIBAUD2 register. In addition, the sub-modes for each chip select are individually programmed in their respective EPIHB16CFGn registers.</p>

Bit/Field	Name	Type	Reset	Description
25:24	CSCFG	RW	0x0	<p>Chip Select Configuration</p> <p>This field controls the chip select options, including an ALE format, a single chip select, two chip selects, and an ALE combined with two chip selects. These bits are also used in combination with the CSCFGEXT bit for further configurations, including quad- chip select.</p> <p>Value Description</p> <p>0x0 ALE Configuration EPI0S30 is used as an address latch (ALE). When using this mode, the address and data should be muxed (HB16MODE field in the EPIHB16CFG register should be configured to 0x0). If needed, the address can be latched by external logic.</p> <p>0x1 CSn Configuration EPI0S30 is used as a Chip Select (CSn). When using this mode, the address and data should not be muxed (MODE field in the EPIHB16CFG register should be configured to 0x1). In this mode, the WR signal (EPI0S29) and the RD signal (EPI0S28) are used to latch the address when CSn is low.</p> <p>0x2 Dual CSn Configuration EPI0S30 is used as CS0n and EPI0S27 is used as CS1n. Whether CS0n or CS1n is asserted is determined by the most significant address bit for a respective external address map. This configuration can be used for a RAM bank split between 2 devices as well as when using both an external RAM and an external peripheral.</p> <p>0x3 ALE with Dual CSn Configuration EPI0S30 is used as address latch (ALE), EPI0S27 is used as CS1n, and EPI0S26 is used as CS0n. Whether CS0n or CS1n is asserted is determined by the most significant address bit for a respective external address map.</p>
23:22	reserved	RO	0x0	Software should not rely on the value of a reserved bit. To provide compatibility with future products, the value of a reserved bit should be preserved across a read-modify-write operation.
21	WRHIGH	RW	0	<p>CS1n WRITE Strobe Polarity</p> <p>This field is used if CSBAUD bit of the EPIHB16CFG2 register is enabled.</p> <p>Value Description</p> <p>0 The WRITE strobe for CS1n accesses is WRn (active Low).</p> <p>1 The WRITE strobe for CS1n accesses is WR (active High).</p>
20	RDHIGH	RW	0	<p>CS1n READ Strobe Polarity</p> <p>This field is used if CSBAUD bit of the EPIHB16CFG2 register is enabled.</p> <p>Value Description</p> <p>0 The READ strobe for CS1n accesses is RDn (active Low).</p> <p>1 The READ strobe for CS1n accesses is RD (active High).</p>

Bit/Field	Name	Type	Reset	Description
19	ALEHIGH	RW	1	<p>CS1n ALE Strobe Polarity</p> <p>This field is used if CSBAUD bit of the EPIHB16CFG2 register is enabled.</p> <p>Value Description</p> <p>0 The address latch strobe for CS1n accesses is ALEn (active Low).</p> <p>1 The address latch strobe for CS1n accesses is ALE (active High).</p>
18	WRCRE	RW	0	<p>CS1n PSRAM Configuration Register Write</p> <p>Used for the PSRAM configuration registers (CR).</p> <p>With WRCRE set, the next transaction by the EPI is a write of the CR bit field in the EPIHBPSRAM register to the configuration register (CR) of the PSRAM. The WRCRE bit self clears once the write-enabled CRE access is complete.</p> <p>Value Description</p> <p>0 No Action.</p> <p>1 Start CRE write transaction for CS1n.</p>
17	RDCRE	RW	0	<p>CS1n PSRAM Configuration Register Read</p> <p>Used for the PSRAM configuration registers (CR).</p> <p>With the RDCRE set, the next access is a read of the PSRAM's Configuration Register (CR). This bit self clears once the CRE access is complete. The address for the CRE access is located at EPIHBPSRAM[19:18]. The read data is returned on EPIHBPSRAM[15:0].</p> <p>Value Description</p> <p>0 No Action.</p> <p>1 Start CRE read transaction for CS1n.</p>
16	BURST	RW	0	<p>CS1n Burst Mode</p> <p>Burst mode must be used with an ALE which is configured by programming the CSCFG and CSCFGEXT fields in the EPIHB16CFG2 register. Burst mode must be used in ADMUX, which is set by the MODE field in EPIHB16CFG2.</p> <p>Note: Burst mode is optimized for word-length accesses.</p> <p>Value Description</p> <p>0 Burst mode is disabled.</p> <p>1 Burst mode is enabled for CS1n.</p>
15:8	reserved	RO	0x0	<p>Software should not rely on the value of a reserved bit. To provide compatibility with future products, the value of a reserved bit should be preserved across a read-modify-write operation.</p>

Bit/Field	Name	Type	Reset	Description
7:6	WRWS	RW	0x0	<p>CS1n Write Wait States</p> <p>This field adds wait states to the data phase of CS1n accesses (the address phase is not affected).</p> <p>The effect is to delay the rising edge of WRn (or the falling edge of WR). Each wait state encoding adds 2 EPI clock cycles to the access time. The WRWSM bit in the EPIHB16TIME2 register can decrease the number of wait states by 1 EPI clock cycle for greater granularity.</p> <p>This field is used if the CSBAUD bit is enabled in the EPIHB16CFG2 register. This field is used in conjunction with the EPIBAUD register and is not applicable in BURST mode.</p> <p>Value Description</p> <p>0x0 Active WRn is 2 EPI clocks</p> <p>0x1 Active WRn is 4 EPI clocks.</p> <p>0x2 Active WRn is 6 EPI clocks</p> <p>0x3 Active WRn is 8 EPI clocks</p>
5:4	RDWS	RW	0x0	<p>CS1n Read Wait States</p> <p>This field adds wait states to the data phase of CS1n accesses (the address phase is not affected).</p> <p>The effect is to delay the rising edge of RDn/Oen (or the falling edge of RD). Each wait state encoding adds 2 EPI clock cycles to the access time. The RDWSM bit in the EPIHB16TIME2 register can decrease the number of states by 1 EPI clock cycle for greater granularity.</p> <p>This field is used if the CSBAUD bit is enabled in the EPIHB16CFG2 register. This field is used in conjunction with the EPIBAUD register and is not applicable in BURST mode.</p> <p>Value Description</p> <p>0x0 Active RDn is 2 EPI clocks</p> <p>0x1 Active RDn is 4 EPI clocks</p> <p>0x2 Active RDn is 6 EPI clocks</p> <p>0x3 Active RDn is 8 EPI clocks</p>
3:2	reserved	RO	0	<p>Software should not rely on the value of a reserved bit. To provide compatibility with future products, the value of a reserved bit should be preserved across a read-modify-write operation.</p>

Bit/Field	Name	Type	Reset	Description								
1:0	MODE	RW	0x0	<p>CS1n Host Bus Sub-Mode</p> <p>This field determines which Host Bus 16 sub-mode to use for CS1n. Sub-mode use is determined by the connected external peripheral. See Table 11-9 on page 841 for information on how this bit field affects the operation of the EPI signals. When used with multiple chip select option this configuration is for CS1n.</p> <p>Note: The CSBAUD bit must be set to enable this CS1n MODE field. If CSBAUD is clear, all chip-selects use the MODE configuration defined in the EPIHB16CFG register.</p> <table border="1"> <thead> <tr> <th>Value</th> <th>Description</th> </tr> </thead> <tbody> <tr> <td>0x0</td> <td> ADMUX – AD[15:0] Data and Address are muxed. </td> </tr> <tr> <td>0x1</td> <td> ADNONMUX – D[15:0] Data and address are separate. This mode is not practical in HB16 mode for normal peripherals because there are generally not enough address bits available. </td> </tr> <tr> <td>0x2-0x3</td> <td>reserved</td> </tr> </tbody> </table>	Value	Description	0x0	ADMUX – AD[15:0] Data and Address are muxed.	0x1	ADNONMUX – D[15:0] Data and address are separate. This mode is not practical in HB16 mode for normal peripherals because there are generally not enough address bits available.	0x2-0x3	reserved
Value	Description											
0x0	ADMUX – AD[15:0] Data and Address are muxed.											
0x1	ADNONMUX – D[15:0] Data and address are separate. This mode is not practical in HB16 mode for normal peripherals because there are generally not enough address bits available.											
0x2-0x3	reserved											

Register 10: EPI Address Map (EPIADDRMAP), offset 0x01C

This register enables address mapping. The EPI controller can directly address memory and peripherals. In addition, the EPI controller supports address mapping to allow indirect accesses in the External RAM and External Peripheral areas.

If the external device is a peripheral, including a FIFO or a directly addressable device, the `EPSZ` and `EPADR` bit fields should be configured for the address space. If the external device is SDRAM, SRAM, or NOR Flash memory, the `ERADR` and `ERSZ` bit fields should be configured for the address space.

If one of the dual chip select modes is selected (`CSCFGEXT` is 0x0 and `CSCFG` is 0x2 or 0x3 in the `EPIHBnCFG2` register), both chip selects can share the peripheral or the memory space, or one chip select can use the peripheral space and the other can use the memory space. In the `EPIADDRMAP` register, if the `EPADR` field is not 0x0, the `ECADR` field is 0x0, and the `ERADR` field is 0x0, then the address specified by `EPADR` is used for both chip selects, with `CS0n` being asserted when the MSB of the address range is 0 and `CS1n` being asserted when the MSB of the address range is 1. If the `ERADR` field is not 0x0, the `ECADR` field is 0x0, and the `EPADR` field is 0x0, then the address specified by `ERADR` is used for both chip selects, with the MSB performing the same delineation. If both the `EPADR` and the `ERADR` are not 0x0 and the `ECADR` field is 0x0, then `CS0n` is asserted for either address range defined by `EPADR` and `CS1n` is asserted for either address range defined by `ERADR`. The two chip selects can also be shared between the code space and memory or peripheral space. If the `ECADR` field is 0x1, `ERADR` field is 0x0, and the `EPADR` field is not 0x0, then `CS0n` is asserted for the address range defined by `ECADR` and `CS1n` is asserted for either address range defined by `EPADR`. If the `ECADR` field is 0x1, `EPADR` field is 0x0, and the `ERADR` field is not 0x0, then `CS0n` is asserted for the address range defined by `ECADR` and `CS1n` is asserted for either address range defined by `ERADR`.

If one of the Quad-Chip-Select modes is selected (`CSCFGEXT` is 0x1 and `CSCFG` is 0x2 or 0x3 in the `EPIHBnCFG2` register), both the peripheral and the memory space must be enabled. In the `EPIADDRMAP` register, the `EPADR` field is 0x3, the `ERADR` field is 0x3, and the `ECADR` field is 0x0. In this case, `CS0n` maps to 0x6000.0000; `CS1n` maps to 0x8000.0000; `CS2n` maps to 0xA000.0000; and `CS3n` maps to 0xC000.0000. The `MODE` field of the `EPIHBnCFGn` registers configures the interface for the individual chip selects, which support `ADMUX` or `ADNOMUX`. If the `CSBAUD` bit is clear, all chip selects use the mode configured in the `MODE` bit field of the `EPIHBnCFG` register. Table 11-5 on page 836 gives a detailed explanation of chip select address range mappings based on which combinations of peripheral and memory space are enabled.

EPI Address Map (EPIADDRMAP)

Base 0x400D.0000
 Offset 0x01C
 Type RW, reset 0x0000.0000

	31	30	29	28	27	26	25	24	23	22	21	20	19	18	17	16
	reserved															
Type	RO	RO	RO	RO	RO	RO	RO	RO	RO	RO	RO	RO	RO	RO	RO	RO
Reset	0	0	0	0	0	0	0	0	0	0	0	0	0	0	0	0
	15	14	13	12	11	10	9	8	7	6	5	4	3	2	1	0
	reserved				ECSZ		ECADR		EPSZ		EPADR		ERSZ		ERADR	
Type	RO	RO	RO	RO	RW	RW	RW	RW	RW	RW	RW	RW	RW	RW	RW	RW
Reset	0	0	0	0	0	0	0	0	0	0	0	0	0	0	0	0

Bit/Field	Name	Type	Reset	Description										
31:12	reserved	RO	0x0000.0	Software should not rely on the value of a reserved bit. To provide compatibility with future products, the value of a reserved bit should be preserved across a read-modify-write operation.										
11:10	ECSZ	RW	0x0	<p>External Code Size</p> <p>This field selects the size of the external code. If the size of the external code is larger, a bus fault occurs. If the size of the external peripheral is smaller, it wraps (upper address bits unused).</p> <p>Note: When not using byte selects in Host-Bus 16, data is accessed on 2-byte boundaries. As a result, the available address space is double the amount shown below.</p> <table border="1"> <thead> <tr> <th>Value</th> <th>Description</th> </tr> </thead> <tbody> <tr> <td>0x0</td> <td>256 bytes; lower address range: 0x00 to 0xFF</td> </tr> <tr> <td>0x1</td> <td>64 KB; lower address range: 0x0000 to 0xFFFF</td> </tr> <tr> <td>0x2</td> <td>16 MB; lower address range: 0x00.0000 to 0xFF.FFFF</td> </tr> <tr> <td>0x3</td> <td>256MB; lower address range: 0x000.0000 to 0xFFFF.FFFF</td> </tr> </tbody> </table>	Value	Description	0x0	256 bytes; lower address range: 0x00 to 0xFF	0x1	64 KB; lower address range: 0x0000 to 0xFFFF	0x2	16 MB; lower address range: 0x00.0000 to 0xFF.FFFF	0x3	256MB; lower address range: 0x000.0000 to 0xFFFF.FFFF
Value	Description													
0x0	256 bytes; lower address range: 0x00 to 0xFF													
0x1	64 KB; lower address range: 0x0000 to 0xFFFF													
0x2	16 MB; lower address range: 0x00.0000 to 0xFF.FFFF													
0x3	256MB; lower address range: 0x000.0000 to 0xFFFF.FFFF													
9:8	ECADR	RW	0x0	<p>External Code Address</p> <p>This field selects address mapping for the external code area.</p> <table border="1"> <thead> <tr> <th>Value</th> <th>Description</th> </tr> </thead> <tbody> <tr> <td>0x0</td> <td>Not mapped</td> </tr> <tr> <td>0x1</td> <td>At 0x1000.0000</td> </tr> <tr> <td>0x2</td> <td>reserved</td> </tr> <tr> <td>0x3</td> <td>reserved</td> </tr> </tbody> </table>	Value	Description	0x0	Not mapped	0x1	At 0x1000.0000	0x2	reserved	0x3	reserved
Value	Description													
0x0	Not mapped													
0x1	At 0x1000.0000													
0x2	reserved													
0x3	reserved													
7:6	EPSZ	RW	0x0	<p>External Peripheral Size</p> <p>This field selects the size of the external peripheral. If the size of the external peripheral is larger, a bus fault occurs. If the size of the external peripheral is smaller, it wraps (upper address bits unused).</p> <p>Note: When not using byte selects in Host-Bus 16, data is accessed on 2-byte boundaries. As a result, the available address space is double the amount shown below.</p> <table border="1"> <thead> <tr> <th>Value</th> <th>Description</th> </tr> </thead> <tbody> <tr> <td>0x0</td> <td>256 bytes; lower address range: 0x00 to 0xFF</td> </tr> <tr> <td>0x1</td> <td>64 KB; lower address range: 0x0000 to 0xFFFF</td> </tr> <tr> <td>0x2</td> <td>16 MB; lower address range: 0x00.0000 to 0xFF.FFFF</td> </tr> <tr> <td>0x3</td> <td>256 MB; lower address range: 0x000.0000 to 0xFFFF.FFFF</td> </tr> </tbody> </table>	Value	Description	0x0	256 bytes; lower address range: 0x00 to 0xFF	0x1	64 KB; lower address range: 0x0000 to 0xFFFF	0x2	16 MB; lower address range: 0x00.0000 to 0xFF.FFFF	0x3	256 MB; lower address range: 0x000.0000 to 0xFFFF.FFFF
Value	Description													
0x0	256 bytes; lower address range: 0x00 to 0xFF													
0x1	64 KB; lower address range: 0x0000 to 0xFFFF													
0x2	16 MB; lower address range: 0x00.0000 to 0xFF.FFFF													
0x3	256 MB; lower address range: 0x000.0000 to 0xFFFF.FFFF													

Bit/Field	Name	Type	Reset	Description
5:4	EPADR	RW	0x0	<p>External Peripheral Address</p> <p>This field selects address mapping for the external peripheral area.</p> <p>Value Description</p> <p>0x0 Not mapped</p> <p>0x1 At 0xA000.0000</p> <p>0x2 At 0xC000.0000</p> <p>0x3 Only to be used with Host Bus quad chip select. In quad chip select mode, CS2n maps to 0xA000.0000 and CS3n maps to 0xC000.0000.</p>
3:2	ERSZ	RW	0x0	<p>External RAM Size</p> <p>This field selects the size of mapped RAM. If the size of the external memory is larger, a bus fault occurs. If the size of the external memory is smaller, it wraps (upper address bits unused):</p> <p>Value Description</p> <p>0x0 256 bytes; lower address range: 0x00 to 0xFF</p> <p>0x1 64 KB; lower address range: 0x0000 to 0xFFFF</p> <p>0x2 16 MB; lower address range: 0x00.0000 to 0xFF.FFFF</p> <p>0x3 256 MB; lower address range: 0x000.0000 to 0xFFF.FFFF</p>
1:0	ERADR	RW	0x0	<p>External RAM Address</p> <p>Selects address mapping for external RAM area:</p> <p>Value Description</p> <p>0x0 Not mapped</p> <p>0x1 At 0x6000.0000</p> <p>0x2 At 0x8000.0000</p> <p>0x3 Only to be used with Host Bus quad chip select. In quad chip select mode, CS0n maps to 0x6000.0000 and CS1n maps to 0x8000.0000.</p>

Register 11: EPI Read Size 0 (EPIRSIZE0), offset 0x020**Register 12: EPI Read Size 1 (EPIRSIZE1), offset 0x030**

This register selects the size of transactions when performing non-blocking reads with the **EPIRPSTDn** registers. This size affects how the external address is incremented.

The **SIZE** field must match the external data width as configured in the **EPIHBnCFG** or **EPIGPCFG** register.

SDRAM mode uses a 16-bit data interface. If **SIZE** is 0x1, data is returned on the least significant bits (D[7:0]), and the remaining bits D[31:8] are all zeros, therefore the data on bits D[15:8] is lost. If **SIZE** is 0x2, data is returned on the least significant bits (D[15:0]), and the remaining bits D[31:16] are all zeros.

Note that changing this register while a read is active has an unpredictable effect.

EPI Read Size n (EPIRSIZEn)

Base 0x400D.0000

Offset 0x020

Type RW, reset 0x0000.0003

	31	30	29	28	27	26	25	24	23	22	21	20	19	18	17	16
	reserved															
Type	RO	RO	RO	RO	RO	RO	RO	RO	RO	RO	RO	RO	RO	RO	RO	RO
Reset	0	0	0	0	0	0	0	0	0	0	0	0	0	0	0	0
	15	14	13	12	11	10	9	8	7	6	5	4	3	2	1	0
	reserved														SIZE	
Type	RO	RO	RO	RO	RO	RO	RO	RO	RO	RO	RO	RO	RO	RO	RW	RW
Reset	0	0	0	0	0	0	0	0	0	0	0	0	0	0	1	1

Bit/Field	Name	Type	Reset	Description
31:2	reserved	RO	0x0000.000	Software should not rely on the value of a reserved bit. To provide compatibility with future products, the value of a reserved bit should be preserved across a read-modify-write operation.
1:0	SIZE	RW	0x3	Current Size
	Value	Description		
	0x0	reserved		
	0x1	Byte (8 bits)		
	0x2	Half-word (16 bits)		
	0x3	Word (32 bits)		

Register 13: EPI Read Address 0 (EPIRADDR0), offset 0x024

Register 14: EPI Read Address 1 (EPIRADDR1), offset 0x034

This register holds the current address value. When performing non-blocking reads via the **EPIRSTDn** registers, this register's value forms the address (when used by the mode). That is, when an **EPIRSTDn** register is written with a non-0 value, this register is used as the first address. After each read, it is incremented by the size specified by the corresponding **EPIRSIZEn** register. Thus at the end of a read, this register contains the next address for the next read. For example, if the last read was 0x20, and the size is word, then the register contains 0x24. When a non-blocking read is cancelled, this register contains the next address that would have been read had it not been cancelled. For example, if reading by bytes and 0x103 had been read but not 0x104, this register contains 0x104. In this manner, the system can determine the number of values in the NBRFIFO to drain.

Note that changing this register while a read is active has an unpredictable effect due to race condition.

EPI Read Address n (EPIRADDRn)

Base 0x400D.0000
 Offset 0x024
 Type RW, reset 0x0000.0000

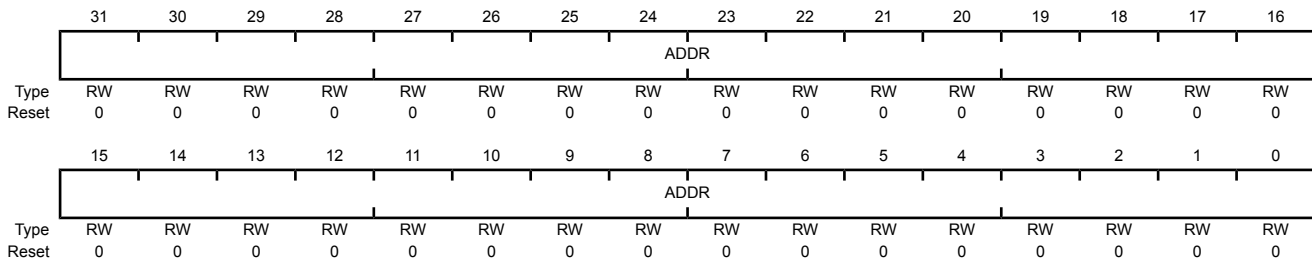

Bit/Field	Name	Type	Reset	Description
31:0	ADDR	RW	0x0000.0000	Current Address Next address to read.

Register 15: EPI Non-Blocking Read Data 0 (EPIRPSTD0), offset 0x028**Register 16: EPI Non-Blocking Read Data 1 (EPIRPSTD1), offset 0x038**

This register sets up a non-blocking read via the external interface. A non-blocking read is started by writing to this register with the count (other than 0). Clearing this register terminates an active non-blocking read as well as cancelling any that are pending. This register should always be cleared before writing a value other than 0; failure to do so can cause improper operation. Note that both NBR channels can be enabled at the same time, but NBR channel 0 has the highest priority and channel 1 does not start until channel 0 is finished.

The first address is based on the corresponding **EPIADDRn** register. The address register is incremented by the size specified by the **EPIRSIZEn** register after each read. If the size is less than a word, only the least significant bits of data are filled into the NBRFIFO; the most significant bits are cleared.

Note that all three registers may be written using one STM instruction, such as with a structure copy in C/C++.

The data may be read from the **EPIREADFIFO** register after the read cycle is completed. The interrupt mechanism is normally used to trigger the FIFO reads via ISR or μ DMA.

If the countdown has not reached 0 and the NBRFIFO is full, the external interface waits until a NBRFIFO entry becomes available to continue.

Note: if a blocking read or write is performed through the address mapped area (at 0x6000.0000 through 0xDFFF.FFFF), any current non-blocking read is paused (at the next safe boundary), and the blocking request is inserted. After completion of any blocking reads or writes, the non-blocking reads continue from where they were paused.

The other way to read data is via the address mapped locations (see the **EPIADDRMAP** register), but this method is blocking (core or μ DMA waits until result is returned).

To cancel a non-blocking read, clear this register. To make sure that all values read are drained from the NBRFIFO, the **EPISTAT** register must be consulted to be certain that bits **NBRBUSY** and **ACTIVE** are cleared. One of these registers should not be cleared until either the other **EPIRPSTDn** register becomes active or the external interface is not busy. At that point, the corresponding **EPIADDRn** register indicates how many values were read.

EPI Non-Blocking Read Data n (EPIRPSTDn)

Base 0x400D.0000
Offset 0x028
Type RW, reset 0x0000.0000

	31	30	29	28	27	26	25	24	23	22	21	20	19	18	17	16
	reserved															
Type	RO	RO	RO	RO	RO	RO	RO	RO	RO	RO	RO	RO	RO	RO	RO	RO
Reset	0	0	0	0	0	0	0	0	0	0	0	0	0	0	0	0
	15	14	13	12	11	10	9	8	7	6	5	4	3	2	1	0
	reserved			POSTCNT												
Type	RO	RO	RO	RW	RW	RW	RW	RW	RW	RW	RW	RW	RW	RW	RW	RW
Reset	0	0	0	0	0	0	0	0	0	0	0	0	0	0	0	0

Bit/Field	Name	Type	Reset	Description
31:13	reserved	RO	0x0000.0	Software should not rely on the value of a reserved bit. To provide compatibility with future products, the value of a reserved bit should be preserved across a read-modify-write operation.

Bit/Field	Name	Type	Reset	Description
12:0	POSTCNT	RW	0x000	Post Count A write of a non-zero value starts a read operation for that count. Note that it is the software's responsibility to handle address wrap-around. Reading this register provides the current count. A write of 0 cancels a non-blocking read (whether active now or pending). Prior to writing a non-zero value, this register must first be cleared.

Register 17: EPI Status (EPISTAT), offset 0x060

This register indicates which non-blocking read register is currently active; it also indicates whether the external interface is busy performing a write or non-blocking read (it cannot be performing a blocking read, as the bus would be blocked and as a result, this register could not be accessed).

This register is useful for determining which non-blocking read register is active when both are loaded with values and when implementing sequencing or sharing.

This register is also useful when canceling non-blocking reads, as it shows how many values were read by the canceled side.

EPI Status (EPISTAT)

Base 0x400D.0000

Offset 0x060

Type RO, reset 0x0000.0000

	31	30	29	28	27	26	25	24	23	22	21	20	19	18	17	16
	reserved															
Type	RO	RO	RO	RO	RO	RO	RO	RO	RO	RO	RO	RO	RO	RO	RO	RO
Reset	0	0	0	0	0	0	0	0	0	0	0	0	0	0	0	0
	15	14	13	12	11	10	9	8	7	6	5	4	3	2	1	0
	reserved							XFFULL	XFEMPTY	INITSEQ	WBUSY	NBRBUSY	reserved			ACTIVE
Type	RO	RO	RO	RO	RO	RO	RO	RO	RO	RO	RO	RO	RO	RO	RO	RO
Reset	0	0	0	0	0	0	0	0	0	0	0	0	0	0	0	0

Bit/Field	Name	Type	Reset	Description				
31:9	reserved	RO	0x0000.00	Software should not rely on the value of a reserved bit. To provide compatibility with future products, the value of a reserved bit should be preserved across a read-modify-write operation.				
8	XFFULL	RO	0	<p>External FIFO Full</p> <p>This bit provides information on the XFIFO when in the FIFO sub-mode of the Host Bus n mode with the XFFEN bit set in the EPIHBnCFG register. The EPIOS26 signal reflects the status of this bit.</p> <p>Value Description</p> <table border="0"> <tr> <td>0</td> <td>The external device is not gating the clock.</td> </tr> <tr> <td>1</td> <td>The XFIFO is signaling as full (the FIFO full signal is high). Attempts to write in this case are stalled until the XFIFO full signal goes low or the counter times out as specified by the MAXWAIT field.</td> </tr> </table>	0	The external device is not gating the clock.	1	The XFIFO is signaling as full (the FIFO full signal is high). Attempts to write in this case are stalled until the XFIFO full signal goes low or the counter times out as specified by the MAXWAIT field.
0	The external device is not gating the clock.							
1	The XFIFO is signaling as full (the FIFO full signal is high). Attempts to write in this case are stalled until the XFIFO full signal goes low or the counter times out as specified by the MAXWAIT field.							
7	XFEMPTY	RO	0	<p>External FIFO Empty</p> <p>This bit provides information on the XFIFO when in the FIFO sub-mode of the Host Bus n mode with the XFEEN bit set in the EPIHBnCFG register. The EPIOS27 signal reflects the status of this bit.</p> <p>Value Description</p> <table border="0"> <tr> <td>0</td> <td>The external device is not gating the clock.</td> </tr> <tr> <td>1</td> <td>The XFIFO is signaling as empty (the FIFO empty signal is high). Attempts to read in this case are stalled until the XFIFO empty signal goes low or the counter times out as specified by the MAXWAIT field.</td> </tr> </table>	0	The external device is not gating the clock.	1	The XFIFO is signaling as empty (the FIFO empty signal is high). Attempts to read in this case are stalled until the XFIFO empty signal goes low or the counter times out as specified by the MAXWAIT field.
0	The external device is not gating the clock.							
1	The XFIFO is signaling as empty (the FIFO empty signal is high). Attempts to read in this case are stalled until the XFIFO empty signal goes low or the counter times out as specified by the MAXWAIT field.							

Bit/Field	Name	Type	Reset	Description
6	INITSEQ	RO	0	<p>Initialization Sequence</p> <p>Value Description</p> <p>0 The SDRAM interface is not in the wakeup period.</p> <p>1 The SDRAM interface is running through the wakeup period (greater than 100 μs). If an attempt is made to read or write the SDRAM during this period, the access is held off until the wakeup period is complete.</p>
5	WBUSY	RO	0	<p>Write Busy</p> <p>Value Description</p> <p>0 The external interface is not performing a write.</p> <p>1 The external interface is performing a write.</p>
4	NBRBUSY	RO	0	<p>Non-Blocking Read Busy</p> <p>Value Description</p> <p>0 The external interface is not performing a non-blocking read.</p> <p>1 The external interface is performing a non-blocking read, or if the non-blocking read is paused due to a write.</p>
3:1	reserved	RO	0x0	<p>Software should not rely on the value of a reserved bit. To provide compatibility with future products, the value of a reserved bit should be preserved across a read-modify-write operation.</p>
0	ACTIVE	RO	0	<p>Register Active</p> <p>Value Description</p> <p>0 If NBRBUSY is set, the EPIRPSTD0 register is active. If the NBRBUSY bit is clear, then neither EPIRPSTDx register is active.</p> <p>1 The EPIRPSTD1 register is active.</p>

Register 18: EPI Read FIFO Count (EPIRFIFOCNT), offset 0x06C

This register returns the number of values in the NBRFIFO (the data in the NBRFIFO can be read via the **EPIREADFIFO** register). A race is possible, but that only means that more values may come in after this register has been read.

EPI Read FIFO Count (EPIRFIFOCNT)

Base 0x400D.0000

Offset 0x06C

Type RO, reset -

	31	30	29	28	27	26	25	24	23	22	21	20	19	18	17	16
	reserved															
Type	RO	RO	RO	RO	RO	RO	RO	RO	RO	RO	RO	RO	RO	RO	RO	RO
Reset	0	0	0	0	0	0	0	0	0	0	0	0	0	0	0	0
	15	14	13	12	11	10	9	8	7	6	5	4	3	2	1	0
	reserved												COUNT			
Type	RO	RO	RO	RO	RO	RO	RO	RO	RO	RO	RO	RO	RO	RO	RO	RO
Reset	0	0	0	0	0	0	0	0	0	0	0	0	-	-	-	-

Bit/Field	Name	Type	Reset	Description
31:4	reserved	RO	0x0000.000	Software should not rely on the value of a reserved bit. To provide compatibility with future products, the value of a reserved bit should be preserved across a read-modify-write operation.
3:0	COUNT	RO	-	FIFO Count Number of filled entries in the NBRFIFO.

Register 19: EPI Read FIFO (EPIREADFIFO0), offset 0x070

Register 20: EPI Read FIFO Alias 1 (EPIREADFIFO1), offset 0x074

Register 21: EPI Read FIFO Alias 2 (EPIREADFIFO2), offset 0x078

Register 22: EPI Read FIFO Alias 3 (EPIREADFIFO3), offset 0x07C

Register 23: EPI Read FIFO Alias 4 (EPIREADFIFO4), offset 0x080

Register 24: EPI Read FIFO Alias 5 (EPIREADFIFO5), offset 0x084

Register 25: EPI Read FIFO Alias 6 (EPIREADFIFO6), offset 0x088

Register 26: EPI Read FIFO Alias 7 (EPIREADFIFO7), offset 0x08C

Important: This register is read-sensitive. See the register description for details.

This register returns the contents of the NBRFIFO or 0 if the NBRFIFO is empty. Each read returns the data that is at the top of the NBRFIFO, and then empties that value from the NBRFIFO. The alias registers can be used with the LDmia instruction for more efficient operation (for up to 8 registers). See *Cortex™-M3/M4 Instruction Set Technical User's Manual (literature number SPMU159)* for more information on the LDmia instruction.

EPI Read FIFn (EPIREADFIFOn)

Base 0x400D.0000

Offset 0x070

Type RO, reset -

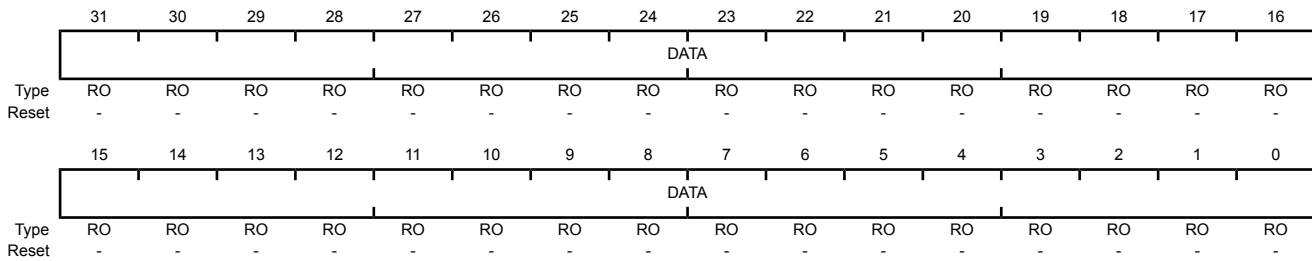

Bit/Field	Name	Type	Reset	Description
31:0	DATA	RO	-	Reads Data This field contains the data that is at the top of the NBRFIFO. After being read, the NBRFIFO entry is removed.

Register 27: EPI FIFO Level Selects (EPIFIFOLVL), offset 0x200

This register allows selection of the FIFO levels which trigger an interrupt to the interrupt controller or, more efficiently, a DMA request to the μ DMA. The NBRFIFO select triggers on fullness such that it triggers on match or above (more full) in order for the processor or the μ DMA to extract the read data. The WFIFO triggers on emptiness such that it triggers on match or below (less entries) in order for the processor or the μ DMA to insert more write data.

It should be noted that the FIFO triggers are not identical to other such FIFOs in TM4C129ENCPDT peripherals. In particular, empty and full triggers are provided to avoid wait states when using blocking operations.

The settings in this register are only meaningful if the μ DMA is active or the interrupt is enabled.

Additionally, this register allows protection against writes stalling and notification of performing blocking reads which stall for extra time due to preceding writes. The two functions behave in a non-orthogonal way because read and write are not orthogonal.

The write error bit configures the system such that an attempted write to an already full WFIFO abandons the write and signals an error interrupt to prevent accidental latencies due to stalling writes.

The read error bit configures the system such that after a read has been stalled due to any preceding writes in the WFIFO, the error interrupt is generated. Note that the excess stall is not prevented, but an interrupt is generated after the fact to notify that it has happened.

EPI FIFO Level Selects (EPIFIFOLVL)

Base 0x400D.0000
Offset 0x200
Type RW, reset 0x0000.0033

	31	30	29	28	27	26	25	24	23	22	21	20	19	18	17	16
	reserved														WFERR	RSERR
Type	RO	RO	RO	RO	RO	RO	RO	RO	RO	RO	RO	RO	RO	RO	RW	RW
Reset	0	0	0	0	0	0	0	0	0	0	0	0	0	0	0	0
	15	14	13	12	11	10	9	8	7	6	5	4	3	2	1	0
	reserved										WRFIFO		reserved	RDFIFO		
Type	RO	RO	RO	RO	RO	RO	RO	RO	RO	RW	RW	RW	RO	RW	RW	RW
Reset	0	0	0	0	0	0	0	0	0	0	1	1	0	0	1	1

Bit/Field	Name	Type	Reset	Description
31:18	reserved	RO	0x0000	Software should not rely on the value of a reserved bit. To provide compatibility with future products, the value of a reserved bit should be preserved across a read-modify-write operation.
17	WFERR	RW	0	Write Full Error
				Value Description
			0	The Write Full error interrupt is disabled. Writes are stalled when the WFIFO is full until a space becomes available but an error is not generated. Note that the Cortex-M3 write buffer may hide that stall if no other memory transactions are attempted during that time.
			1	This bit enables the Write Full error interrupt (WTFULL in the EPIEISC register) to be generated when a write is attempted and the WFIFO is full. The write stalls until a WFIFO entry becomes available.

Bit/Field	Name	Type	Reset	Description
16	RSERR	RW	0	<p>Read Stall Error</p> <p>Value Description</p> <p>0 The Read Stalled error interrupt is disabled. Reads behave as normal and are stalled until any preceding writes have completed and the read has returned a result.</p> <p>1 This bit enables the Read Stalled error interrupt (<code>RSTALL</code> in the EPIEISC register) to be generated when a read is attempted and the WFIFO is not empty. The read is still stalled during the time the WFIFO drains, but this error notifies the application that this excess delay has occurred.</p> <p>Note that the configuration of this bit has no effect on non-blocking reads.</p>
15:7	reserved	RO	0x00	Software should not rely on the value of a reserved bit. To provide compatibility with future products, the value of a reserved bit should be preserved across a read-modify-write operation.
6:4	WRFIFO	RW	0x3	<p>Write FIFO</p> <p>Value Description</p> <p>0x0 Interrupt is triggered while WRFIFO is empty. It will be deasserted when not empty. This encoding is optimized for burst of 4 writes.</p> <p>0x1 reserved</p> <p>0x2 Interrupt is triggered until there are only two slots available. Thus, trigger is deasserted when there are two WRFIFO entries present. This configuration is optimized for bursts of 2.</p> <p>0x3 Interrupt is triggered until there is one WRFIFO entry available. This configuration expects only single writes.</p> <p>0x4 Trigger interrupt when WRFIFO is not full, meaning trigger will continue to assert until there are four entries in the WRFIFO.</p> <p>0x5-0x7 reserved</p>
3	reserved	RO	0	Software should not rely on the value of a reserved bit. To provide compatibility with future products, the value of a reserved bit should be preserved across a read-modify-write operation.
2:0	RDFIFO	RW	0x3	<p>Read FIFO</p> <p>This field configures the trigger point for the NBRFIFO.</p> <p>Value Description</p> <p>0x0 reserved</p> <p>0x1 Trigger when there are 1 or more entries in the NBRFIFO.</p> <p>0x2 Trigger when there are 2 or more entries in the NBRFIFO.</p> <p>0x3 Trigger when there are 4 or more entries in the NBRFIFO.</p> <p>0x4 Trigger when there are 6 or more entries in the NBRFIFO.</p> <p>0x5 Trigger when there are 7 or more entries in the NBRFIFO.</p> <p>0x6 Trigger when there are 8 entries in the NBRFIFO.</p> <p>0x7 reserved</p>

Register 28: EPI Write FIFO Count (EPIWFIFOCNT), offset 0x204

This register contains the number of slots currently available in the WFIFO. This register may be used for polled writes to avoid stalling and for blocking reads to avoid excess stalling (due to undrained writes). An example use for writes may be:

```
for (idx = 0; idx < cnt; idx++) {
while (EPIWFIFOCNT == 0) ;
*ext_ram = *mydata++;
}
```

The above code ensures that writes to the address mapped location do not occur unless the WFIFO has room. Although polling makes the code wait (spinning in the loop), it does not prevent interrupts being serviced due to bus stalling.

EPI Write FIFO Count (EPIWFIFOCNT)

Base 0x400D.0000

Offset 0x204

Type RO, reset 0x0000.0004

	31	30	29	28	27	26	25	24	23	22	21	20	19	18	17	16
	reserved															
Type	RO	RO	RO	RO	RO	RO	RO	RO	RO	RO	RO	RO	RO	RO	RO	RO
Reset	0	0	0	0	0	0	0	0	0	0	0	0	0	0	0	0
	15	14	13	12	11	10	9	8	7	6	5	4	3	2	1	0
	reserved													WTAV		
Type	RO	RO	RO	RO	RO	RO	RO	RO	RO	RO	RO	RO	RO	RO	RO	RO
Reset	0	0	0	0	0	0	0	0	0	0	0	0	0	0	1	0

Bit/Field	Name	Type	Reset	Description
31:3	reserved	RO	0x0000.000	Software should not rely on the value of a reserved bit. To provide compatibility with future products, the value of a reserved bit should be preserved across a read-modify-write operation.
2:0	WTAV	RO	0x4	Available Write Transactions The number of write transactions available in the WFIFO. When clear, a write is stalled waiting for a slot to become free (from a preceding write completing).

Register 29: EPI DMA Transmit Count (EPIDMATXCNT), offset 0x208

This register is used to program the total number of transfers (byte, halfword or word) by the μ DMA to WRFIFO. As each transfer is processed by the EPI, the TXCNT bit field value is decreased by 1. When TXCNT = 0, the EPI's uDMA request signal is deasserted.

EPI DMA Transmit Count (EPIDMATXCNT)

Base 0x400D.0000
 Offset 0x208
 Type RW, reset 0x0000.0000

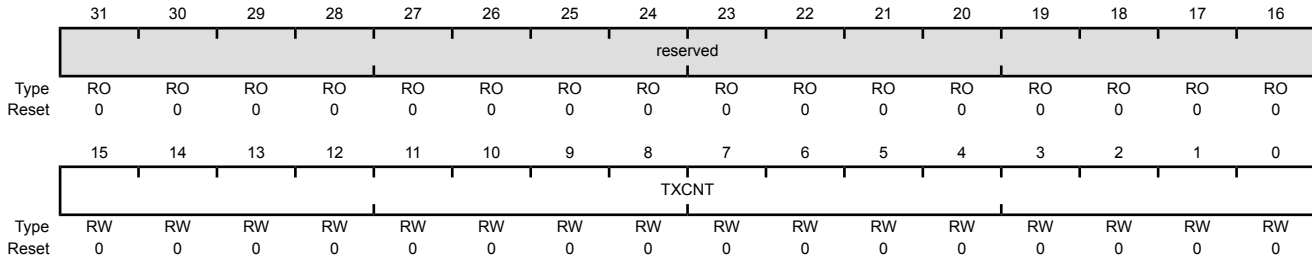

Bit/Field	Name	Type	Reset	Description
31:16	reserved	RO	0x0000	Software should not rely on the value of a reserved bit. To provide compatibility with future products, the value of a reserved bit should be preserved across a read-modify-write operation.
15:0	TXCNT	RW	0x0000	DMA Count This field is used to program the total number of transfers (byte, halfword or word) from the μ DMA to the EPI WRFIFO.

Register 30: EPI Interrupt Mask (EPIIM), offset 0x210

This register is the interrupt mask set or clear register. For each interrupt source (read, write, and error), a mask value of 1 allows the interrupt source to trigger an interrupt to the interrupt controller; a mask value of 0 prevents the interrupt source from triggering an interrupt.

EPI Interrupt Mask (EPIIM)

Base 0x400D.0000

Offset 0x210

Type RW, reset 0x0000.0000

	31	30	29	28	27	26	25	24	23	22	21	20	19	18	17	16	
	reserved																
Type	RO	RO	RO	RO	RO	RO	RO	RO	RO	RO	RO	RO	RO	RO	RO	RO	
Reset	0	0	0	0	0	0	0	0	0	0	0	0	0	0	0	0	
	15	14	13	12	11	10	9	8	7	6	5	4	3	2	1	0	
	reserved												DMAWRIM	DMARDIM	WRIM	RDIM	ERRIM
Type	RO	RO	RO	RO	RO	RO	RO	RO	RO	RO	RO	RW	RW	RW	RW	RW	
Reset	0	0	0	0	0	0	0	0	0	0	0	0	0	0	0	0	

Bit/Field	Name	Type	Reset	Description
31:5	reserved	RO	0x000	Software should not rely on the value of a reserved bit. To provide compatibility with future products, the value of a reserved bit should be preserved across a read-modify-write operation.
4	DMAWRIM	RW	0	Write uDMA Interrupt Mask Value Description 0 DMAWRRIS in the EPIRIS register is masked and does not cause an interrupt. 1 DMAWRRIS in the EPIRIS register is not masked and can trigger an interrupt to the interrupt controller.
3	DMARDIM	RW	0	Read uDMA Interrupt Mask Value Description 0 DMARDRIS in the EPIRIS register is masked and does not cause an interrupt. 1 DMARDRIS in the EPIRIS register is not masked and can trigger an interrupt to the interrupt controller.
2	WRIM	RW	0	Write FIFO Empty Interrupt Mask Value Description 0 WRRIS in the EPIRIS register is masked and does not cause an interrupt. 1 WRRIS in the EPIRIS register is not masked and can trigger an interrupt to the interrupt controller.

Bit/Field	Name	Type	Reset	Description
1	RDIM	RW	0	Read FIFO Full Interrupt Mask Value Description 0 RDRIS in the EPIRIS register is masked and does not cause an interrupt. 1 RDRIS in the EPIRIS register is not masked and can trigger an interrupt to the interrupt controller.
0	ERRIM	RW	0	Error Interrupt Mask Value Description 0 ERRIS in the EPIRIS register is masked and does not cause an interrupt. 1 ERRIS in the EPIRIS register is not masked and can trigger an interrupt to the interrupt controller.

Register 31: EPI Raw Interrupt Status (EPIRIS), offset 0x214

This register is the raw interrupt status register. On a read, it gives the current state of each interrupt source. A write has no effect.

Note that raw status for read and write is set or cleared based on FIFO fullness as controlled by **EPIFIFOLVL**.

Raw status for error is held until the error is cleared by writing to the **EPIEISC** register.

EPI Raw Interrupt Status (EPIRIS)

Base 0x400D.0000

Offset 0x214

Type RO, reset 0x0000.0004

	31	30	29	28	27	26	25	24	23	22	21	20	19	18	17	16	
	reserved																
Type	RO	RO	RO	RO	RO	RO	RO	RO	RO	RO	RO	RO	RO	RO	RO	RO	
Reset	0	0	0	0	0	0	0	0	0	0	0	0	0	0	0	0	
	15	14	13	12	11	10	9	8	7	6	5	4	3	2	1	0	
	reserved												DMAWRRIS	DMARDRIS	WRRIS	RDRIS	ERRRIS
Type	RO	RO	RO	RO	RO	RO	RO	RO	RO	RO	RO	RO	RO	RO	RO	RO	
Reset	0	0	0	0	0	0	0	0	0	0	0	0	0	0	1	0	

Bit/Field	Name	Type	Reset	Description
31:5	reserved	RO	0x000	Software should not rely on the value of a reserved bit. To provide compatibility with future products, the value of a reserved bit should be preserved across a read-modify-write operation.
4	DMAWRRIS	RO	0	Write uDMA Raw Interrupt Status Value Description 0 The write uDMA has not completed. 1 The write uDMA has completed. This bit is cleared by writing a 1 to the DMAWRIC bit in the EPIEISC register.
3	DMARDRIS	RO	0	Read uDMA Raw Interrupt Status Value Description 0 The read uDMA has not completed. 1 The read uDMA has completed. This bit is cleared by writing a 1 to the DMARDIC bit in the EPIEISC register.

Bit/Field	Name	Type	Reset	Description
2	WRRIS	RO	1	<p>Write Raw Interrupt Status</p> <p>Value Description</p> <p>0 The number of available entries in the WFIFO is above the range specified by the <code>WRFIFO</code> field in the EPIFIFOLVL register.</p> <p>1 The number of available entries in the WFIFO is within the trigger range specified by the <code>WRFIFO</code> field in the EPIFIFOLVL register.</p> <p>This bit is cleared when the level in the WFIFO is above the trigger point programmed by the <code>WRFIFO</code> field.</p>
1	RDRIS	RO	0	<p>Read Raw Interrupt Status</p> <p>Value Description</p> <p>0 The number of valid entries in the NBRFIFO is below the trigger range specified by the <code>RDFIFO</code> field in the EPIFIFOLVL register.</p> <p>1 The number of valid entries in the NBRFIFO is in the trigger range specified by the <code>RDFIFO</code> field in the EPIFIFOLVL register.</p> <p>This bit is cleared when the level in the NBRFIFO is below the trigger point programmed by the <code>RDFIFO</code> field.</p>
0	ERRRIS	RO	0	<p>Error Raw Interrupt Status</p> <p>The error interrupt occurs in the following situations:</p> <ul style="list-style-type: none"> ■ WFIFO Full. For a full WFIFO to generate an error interrupt, the <code>WFERR</code> bit in the EPIFIFOLVL register must be set. ■ Read Stalled. For a stalled read to generate an error interrupt, the <code>RSERR</code> bit in the EPIFIFOLVL register must be set. ■ Timeout. If the <code>MAXWAIT</code> field in the EPIHBnCFG register is configured to a value other than 0, a timeout error occurs when XFIFO not-ready signals hold a transaction for more than the count in the <code>MAXWAIT</code> field. <p>Value Description</p> <p>0 An error has not occurred.</p> <p>1 A WFIFO Full, a Read Stalled, or a Timeout error has occurred.</p> <p>To determine which error occurred, read the status of the EPI Error Interrupt Status and Clear (EPIEISC) register. This bit is cleared by writing a 1 to the bit in the EPIEISC register that caused the interrupt.</p>

Register 32: EPI Masked Interrupt Status (EPIMIS), offset 0x218

This register is the masked interrupt status register. On read, it gives the current state of each interrupt source (read, write, and error) after being masked via the **EPIIM** register. A write has no effect.

The values returned are the ANDing of the **EPIIM** and **EPIRIS** registers. If a bit is set in this register, the interrupt is sent to the interrupt controller.

EPI Masked Interrupt Status (EPIMIS)

Base 0x400D.0000

Offset 0x218

Type RO, reset 0x0000.0000

	31	30	29	28	27	26	25	24	23	22	21	20	19	18	17	16	
	reserved																
Type	RO	RO	RO	RO	RO	RO	RO	RO	RO	RO	RO	RO	RO	RO	RO	RO	
Reset	0	0	0	0	0	0	0	0	0	0	0	0	0	0	0	0	
	15	14	13	12	11	10	9	8	7	6	5	4	3	2	1	0	
	reserved												DMAWRMIS	DMARDMIS	WRMIS	RDMIS	ERRMIS
Type	RO	RO	RO	RO	RO	RO	RO	RO	RO	RO	RO	RO	RO	RO	RO	RO	
Reset	0	0	0	0	0	0	0	0	0	0	0	0	0	0	0	0	

Bit/Field	Name	Type	Reset	Description						
31:5	reserved	RO	0x000	Software should not rely on the value of a reserved bit. To provide compatibility with future products, the value of a reserved bit should be preserved across a read-modify-write operation.						
4	DMAWRMIS	RO	0	Write uDMA Masked Interrupt Status <table border="0"> <tr> <td>Value</td> <td>Description</td> </tr> <tr> <td>0</td> <td>The write uDMA has not completed or the interrupt is masked.</td> </tr> <tr> <td>1</td> <td>The write uDMA has completed and the DMAWRIM bit in the EPIIM register is set, triggering an interrupt to the interrupt controller.</td> </tr> </table> <p>This bit is cleared by writing a 1 to the DMAWRIC bit in the EPIEISC register.</p>	Value	Description	0	The write uDMA has not completed or the interrupt is masked.	1	The write uDMA has completed and the DMAWRIM bit in the EPIIM register is set, triggering an interrupt to the interrupt controller.
Value	Description									
0	The write uDMA has not completed or the interrupt is masked.									
1	The write uDMA has completed and the DMAWRIM bit in the EPIIM register is set, triggering an interrupt to the interrupt controller.									
3	DMARDMIS	RO	0	Read uDMA Masked Interrupt Status <table border="0"> <tr> <td>Value</td> <td>Description</td> </tr> <tr> <td>0</td> <td>The read uDMA has not completed or the interrupt is masked.</td> </tr> <tr> <td>1</td> <td>The read uDMA has completed and the DMARDIM bit in the EPIIM register is set, triggering an interrupt to the interrupt controller.</td> </tr> </table> <p>This bit is cleared by writing a 1 to the DMARDIC bit in the EPIEISC register.</p>	Value	Description	0	The read uDMA has not completed or the interrupt is masked.	1	The read uDMA has completed and the DMARDIM bit in the EPIIM register is set, triggering an interrupt to the interrupt controller.
Value	Description									
0	The read uDMA has not completed or the interrupt is masked.									
1	The read uDMA has completed and the DMARDIM bit in the EPIIM register is set, triggering an interrupt to the interrupt controller.									

Bit/Field	Name	Type	Reset	Description
2	WRMIS	RO	0	<p>Write Masked Interrupt Status</p> <p>Value Description</p> <p>0 The number of available entries in the WFIFO is above the range specified by the trigger level or the interrupt is masked.</p> <p>1 The number of available entries in the WFIFO is within the range specified by the trigger level (the <code>WRFIFO</code> field in the EPIFIFOLVL register) and the <code>WRIM</code> bit in the EPIIM register is set, triggering an interrupt to the interrupt controller.</p>
1	RDMIS	RO	0	<p>Read Masked Interrupt Status</p> <p>Value Description</p> <p>0 The number of valid entries in the NBRFIFO is below the range specified by the trigger level or the interrupt is masked.</p> <p>1 The number of valid entries in the NBRFIFO is within the range specified by the trigger level (the <code>RDFIFO</code> field in the EPIFIFOLVL register) and the <code>RDIM</code> bit in the EPIIM register is set, triggering an interrupt to the interrupt controller.</p>
0	ERRMIS	RO	0	<p>Error Masked Interrupt Status</p> <p>Value Description</p> <p>0 An error has not occurred or the interrupt is masked.</p> <p>1 A WFIFO Full, a Read Stalled, or a Timeout error has occurred and the <code>ERIM</code> bit in the EPIIM register is set, triggering an interrupt to the interrupt controller.</p>

Register 33: EPI Error and Interrupt Status and Clear (EPIEISC), offset 0x21C

This register is used to clear a pending error interrupt. Clearing any defined bit in the **EPIEISC** has no effect; setting a bit clears the error source and the raw error returns to 0. When any of bits[2:0] of this register are read as set, it indicates that the **ERRRIS** bit in the **EPIRIS** register is set and an EPI controller error is sent to the interrupt controller if the **ERIM** bit in the **EPIIM** register is set. If any of bits [2:0] are written as 1, the register bit being written to, as well as the **ERRRIS** bit in the **EPIRIS** register and the **ERIM** bit in the **EPIIM** register are cleared. If the **DMAWRIC** or **DMARDIC** bit in this register is set, then the corresponding bit in the **EPIRIS** and **EPIMIS** register is cleared. Note that writing to this register and reading back immediately (pipelined by the processor) returns the old register contents. One cycle is needed between write and read.

EPI Error and Interrupt Status and Clear (EPIEISC)

Base 0x400D.0000

Offset 0x21C

Type RW1C, reset 0x0000.0000

	31	30	29	28	27	26	25	24	23	22	21	20	19	18	17	16	
	reserved																
Type	RO	RO	RO	RO	RO	RO	RO	RO	RO	RO	RO	RO	RO	RO	RO	RO	
Reset	0	0	0	0	0	0	0	0	0	0	0	0	0	0	0	0	
	15	14	13	12	11	10	9	8	7	6	5	4	3	2	1	0	
	reserved												DMAWRIC	DMARDIC	WTFULL	RSTALL	TOUT
Type	RO	RO	RO	RO	RO	RO	RO	RO	RO	RO	RO	W1C	W1C	RW1C	RW1C	RW1C	
Reset	0	0	0	0	0	0	0	0	0	0	0	0	0	0	0	0	

Bit/Field	Name	Type	Reset	Description
31:5	reserved	RO	0x000	Software should not rely on the value of a reserved bit. To provide compatibility with future products, the value of a reserved bit should be preserved across a read-modify-write operation.
4	DMAWRIC	W1C	0	Write uDMA Interrupt Clear Writing a 1 to this bit clears the DMAWRRIS bit in the EPIRIS register and the DMAWRMIS bit in the EPIMIS register.
3	DMARDIC	W1C	0	Read uDMA Interrupt Clear Writing a 1 to this bit clears the DMARDRIS bit in the EPIRIS register and the DMARDMIS bit in the EPIMIS register.
2	WTFULL	RW1C	0	Write FIFO Full Error Value Description 0 The WFERR bit is not enabled or no writes are stalled. 1 The WFERR bit is enabled and a write is stalled due to the WFIFO being full. Writing a 1 to this bit clears it, as well as the ERRRIS and ERIM bits.
1	RSTALL	RW1C	0	Read Stalled Error Value Description 0 The RSERR bit is not enabled or no pending reads are stalled. 1 The RSERR bit is enabled and a pending read is stalled due to writes in the WFIFO. Writing a 1 to this bit clears it, as well as the ERRRIS and ERIM bits.

Bit/Field	Name	Type	Reset	Description
0	TOUT	RW1C	0	<p>Timeout Error</p> <p>This bit is the timeout error source. The timeout error occurs when the XFIFO not-ready signals hold a transaction for more than the count in the MAXWAIT field (when not 0).</p> <p>Value Description</p> <p>0 No timeout error has occurred.</p> <p>1 A timeout error has occurred.</p> <p>Writing a 1 to this bit clears it, as well as the ERRRIS and ERIM bits.</p>

Register 34: EPI Host-Bus 8 Configuration 3 (EPIHB8CFG3), offset 0x308

Important: The `MODE` field in the `EPICFG` register configures whether EPI Host Bus mode is enabled. For `EPIHB8CFG3` to be valid, the `MODE` field must be 0x2.

EPI Host-Bus 8 Configuration 3 (EPIHB8CFG3)

Base 0x400D.0000

Offset 0x308

Type RW, reset 0x0008.0000

	31	30	29	28	27	26	25	24	23	22	21	20	19	18	17	16
	reserved										WRHIGH	RDHIGH	ALEHIGH	reserved		
Type	RO	RO	RO	RO	RO	RO	RO	RO	RO	RO	RW	RW	RW	RO	RO	RO
Reset	0	0	0	0	0	0	0	0	0	0	0	0	1	0	0	0
	15	14	13	12	11	10	9	8	7	6	5	4	3	2	1	0
	reserved								WRWS		RDWS		reserved		MODE	
Type	RO	RO	RO	RO	RO	RO	RO	RO	RW	RW	RW	RW	RO	RO	RW	RW
Reset	0	0	0	0	0	0	0	0	0	0	0	0	0	0	0	0

Bit/Field	Name	Type	Reset	Description
31:22	reserved	RO	0x000	Software should not rely on the value of a reserved bit. To provide compatibility with future products, the value of a reserved bit should be preserved across a read-modify-write operation.
21	WRHIGH	RW	0	CS2n WRITE Strobe Polarity This field is used if the <code>CSBAUD</code> bit is enabled in EPIHB8CFG2 . Value Description 0 The WRITE strobe for CS2n accesses is WRn (active Low). 1 The WRITE strobe for CS2n accesses is WR (active High).
20	RDHIGH	RW	0	CS2n READ Strobe Polarity This field is used if the <code>CSBAUD</code> bit is enabled in EPIHB8CFG2 . Value Description 0 The READ strobe for CS2n accesses is RDn (active Low). 1 The READ strobe for CS2n accesses is RD (active High).
19	ALEHIGH	RW	1	CS2n ALE Strobe Polarity This field is used if the <code>CSBAUD</code> bit is enabled in EPIHB8CFG2 . Value Description 0 The address latch strobe for CS2n accesses is ADVn (active Low). 1 The address latch strobe for CS2n accesses is ALE (active High).
18:8	reserved	RO	0x00	Software should not rely on the value of a reserved bit. To provide compatibility with future products, the value of a reserved bit should be preserved across a read-modify-write operation.

Bit/Field	Name	Type	Reset	Description
7:6	WRWS	RW	0x0	<p>CS2n Write Wait States</p> <p>This field adds wait states to the data phase of CS2n accesses (the address phase is not affected).</p> <p>The effect is to delay the rising edge of WRn (or the falling edge of WR). Each wait state adds 2 EPI clock cycles to the access time. The WRWSM bit in the EPIHB8TIME3 register can decrease the number of wait states by 1 EPI clock cycle for greater granularity. This field is used if the CSBAUD bit is enabled in the EPIHB8CFG2 register. This field is not applicable in BURST mode.</p> <p>Value Description</p> <p>0x0 Active WRn is 2 EPI clocks</p> <p>0x1 Active WRn is 4 EPI clocks</p> <p>0x2 Active WRn is 6 EPI clocks</p> <p>0x3 Active WRn is 8 EPI clocks</p> <p>This field is used in conjunction with the EPIBAUD2 register.</p>
5:4	RDWS	RW	0x0	<p>CS2n Read Wait States</p> <p>This field adds wait states to the data phase of CS2n accesses (the address phase is not affected).</p> <p>The effect is to delay the rising edge of RDn/Oen (or the falling edge of RD). Each wait state adds 2 EPI clock cycles to the access time. The RDWSM bit in the EPIHB8TIME3 register can decrease the number of wait states by 1 EPI clock cycle for greater granularity. This field is used if the CSBAUD bit is enabled in the EPIHB8CFG2 register. This field is not applicable in BURST mode.</p> <p>Value Description</p> <p>0x0 Active RDn is 2 EPI clocks</p> <p>0x1 Active RDn is 4 EPI clocks</p> <p>0x2 Active RDn is 6 EPI clocks</p> <p>0x3 Active RDn is 8 EPI clocks</p> <p>This field is used in conjunction with the EPIBAUD2 register.</p>
3:2	reserved	RO	0x0	<p>Software should not rely on the value of a reserved bit. To provide compatibility with future products, the value of a reserved bit should be preserved across a read-modify-write operation.</p>

Bit/Field	Name	Type	Reset	Description								
1:0	MODE	RW	0x0	<p>CS2n Host Bus Sub-Mode</p> <p>This field determines which Host Bus 8 sub-mode to use for CS2n in multiple chip-select mode.</p> <p>Sub-mode use is determined by the connected external peripheral. See Table 11-8 on page 839 for information on how this bit field affects the operation of the EPI signals.</p> <p>Note: The CSBAUD bit must be set to enable this CS2n MODE field. If CSBAUD is clear, all chip-selects use the MODE configuration defined in the EPIHB8CFG register.</p> <table border="1"> <thead> <tr> <th>Value</th> <th>Description</th> </tr> </thead> <tbody> <tr> <td>0x0</td> <td>ADMUX – AD[7:0] Data and Address are muxed.</td> </tr> <tr> <td>0x1</td> <td>ADNONMUX – D[7:0] Data and address are separate.</td> </tr> <tr> <td>0x2-0x3</td> <td>reserved</td> </tr> </tbody> </table>	Value	Description	0x0	ADMUX – AD[7:0] Data and Address are muxed.	0x1	ADNONMUX – D[7:0] Data and address are separate.	0x2-0x3	reserved
Value	Description											
0x0	ADMUX – AD[7:0] Data and Address are muxed.											
0x1	ADNONMUX – D[7:0] Data and address are separate.											
0x2-0x3	reserved											

Register 35: EPI Host-Bus 16 Configuration 3 (EPIHB16CFG3), offset 0x308

Important: The `MODE` field in the `EPICFG` register determines which configuration is enabled.

For **EPIHB16CFG3** to be valid, the `MODE` field must be 0x3.

EPI Host-Bus 16 Configuration 3 (EPIHB16CFG3)

Base 0x400D.0000

Offset 0x308

Type RW, reset 0x0008.0000

	31	30	29	28	27	26	25	24	23	22	21	20	19	18	17	16
	reserved										WRHIGH	RDHIGH	ALEHIGH	WRCRE	RDCRE	BURST
Type	RO	RO	RO	RO	RO	RO	RO	RO	RO	RO	RW	RW	RW	RW	RW	RW
Reset	0	0	0	0	0	0	0	0	0	0	0	0	1	0	0	0
	15	14	13	12	11	10	9	8	7	6	5	4	3	2	1	0
	reserved										WRWS	RDWS	reserved		MODE	
Type	RO	RO	RO	RO	RO	RO	RO	RO	RO	RO	RW	RW	RW	RW	RO	RO
Reset	0	0	0	0	0	0	0	0	0	0	0	0	0	0	0	0

Bit/Field	Name	Type	Reset	Description
31:22	reserved	RO	0x000	Software should not rely on the value of a reserved bit. To provide compatibility with future products, the value of a reserved bit should be preserved across a read-modify-write operation.
21	WRHIGH	RW	0	CS2n WRITE Strobe Polarity This field is used if the <code>CSBAUD</code> bit is enabled in EPIHB16CFG2 . Value Description 0 The WRITE strobe for CS2n accesses is WRn (active Low). 1 The WRITE strobe for CS2n accesses is WR (active High).
20	RDHIGH	RW	0	CS2n READ Strobe Polarity This field is used if the <code>CSBAUD</code> bit is enabled in EPIHB16CFG2 . Value Description 0 The READ strobe for CS2n accesses is RDn (active Low). 1 The READ strobe for CS2n accesses is RD (active High).
19	ALEHIGH	RW	1	CS2n ALE Strobe Polarity This field is used if the <code>CSBAUD</code> bit is enabled in EPIHB16CFG2 . Value Description 0 The address latch strobe for CS2n accesses is ADVn (active Low). 1 The address latch strobe for CS2n accesses is ALE (active High).

Bit/Field	Name	Type	Reset	Description
18	WRCRE	RW	0	<p>CS2n PSRAM Configuration Register Write</p> <p>Used for PSRAM configuration registers.</p> <p>With <code>WRCRE</code> set, the next transaction by the EPI is a write of the <code>CR</code> bit field in the EPIHBPSRAM register to the configuration register (CR) of the PSRAM. The <code>WRCRE</code> bit self clears once the write-enabled CRE access is complete.</p> <p>Value Description</p> <p>0 No Action.</p> <p>1 Start CRE write transaction for CS2n.</p>
17	RDCRE	RW	0	<p>CS2n PSRAM Configuration Register Read</p> <p>Used for PSRAM configuration registers.</p> <p>With the <code>RDCRE</code> set, the next access is a read of the PSRAM's Configuration Register (CR). This bit self clears once the CRE access is complete. The address for the CRE access is located at EPIHBPSRAM[19:18]. The read data is returned on EPIHBPSRAM[15:0].</p> <p>Value Description</p> <p>0 No Action.</p> <p>1 Start CRE read transaction for CS2n.</p>
16	BURST	RW	0	<p>CS2n Burst Mode</p> <p>Burst mode must be used with an ALE, which is configured by programming the <code>CSCFG</code> and <code>CSCFGEXT</code> fields in the EPIHB16CFG2 register. Burst mode must be used in ADMUX, which is set by the <code>MODE</code> field in EPIHB16CFG3.</p> <p>Note: Burst mode is optimized for word-length accesses.</p> <p>Value Description</p> <p>0 Burst mode is disabled.</p> <p>1 Burst mode is enabled for CS2n.</p>
15:8	reserved	RO	0x00	<p>Software should not rely on the value of a reserved bit. To provide compatibility with future products, the value of a reserved bit should be preserved across a read-modify-write operation.</p>

Bit/Field	Name	Type	Reset	Description
7:6	WRWS	RW	0x0	<p>CS2n Write Wait States</p> <p>This field adds wait states to the data phase of CS2n accesses (the address phase is not affected).</p> <p>The effect is to delay the rising edge of WRn (or the falling edge of WR). Each wait state adds 2 EPI clock cycles to the access time. The <code>WRWSM</code> bit in the EPIHB16TIME3 register can decrease the number of wait states by 1 EPI clock cycle for greater granularity. This field is used if the EPIHB16CFG2 register. This field is not applicable in BURST mode.</p> <p>Value Description</p> <p>0x0 Active WRn is 2 EPI clocks</p> <p>0x1 Active WRn is 4 EPI clocks</p> <p>0x2 Active WRn is 6 EPI clocks</p> <p>0x3 Active WRn is 8 EPI clocks</p> <p>This field is used in conjunction with the EPIBAUD2 register.</p>
5:4	RDWS	RW	0x0	<p>CS2n Read Wait States</p> <p>This field adds wait states to the data phase of CS2n accesses (the address phase is not affected).</p> <p>The effect is to delay the rising edge of RDn/Oen (or the falling edge of RD). Each wait state adds 2 EPI clock cycles to the access time. The <code>RDWSM</code> bit in the EPIHB16TIME3 register can decrease the number of wait states by 1 EPI clock cycle for greater granularity. This field is used if the <code>CSBAUD</code> bit is enabled in the EPIHB16CFG2 register.</p> <p>This field is not applicable in BURST mode.</p> <p>Value Description</p> <p>0x0 Active RDn is 2 EPI clocks</p> <p>0x1 Active RDn is 4 EPI clocks</p> <p>0x2 Active RDn is 6 EPI clocks</p> <p>0x3 Active RDn is 8 EPI clocks</p> <p>This field is used in conjunction with the EPIBAUD2 register.</p>
3:2	reserved	RO	0	<p>Software should not rely on the value of a reserved bit. To provide compatibility with future products, the value of a reserved bit should be preserved across a read-modify-write operation.</p>

Bit/Field	Name	Type	Reset	Description								
1:0	MODE	RW	0x0	<p>CS2n Host Bus Sub-Mode</p> <p>This field determines which Host Bus 16 sub-mode to use for CS2n in multiple chip select mode.</p> <p>Sub-mode use is determined by the connected external peripheral. See Table 11-9 on page 841 for information on how this bit field affects the operation of the EPI signals.</p> <p>Note: The CSBAUD bit must be set to enable this CS2n MODE field. If CSBAUD is clear, all chip-selects use the MODE configuration defined in the EPIHB16CFG register.</p> <table border="1"> <thead> <tr> <th>Value</th> <th>Description</th> </tr> </thead> <tbody> <tr> <td>0x0</td> <td> ADMUX – AD[15:0] Data and Address are muxed. </td> </tr> <tr> <td>0x1</td> <td> ADNONMUX – D[15:0] Data and address are separate. This mode is not practical in HB16 mode for normal peripherals because there are generally not enough address bits available. </td> </tr> <tr> <td>0x2-0x3</td> <td>reserved</td> </tr> </tbody> </table>	Value	Description	0x0	ADMUX – AD[15:0] Data and Address are muxed.	0x1	ADNONMUX – D[15:0] Data and address are separate. This mode is not practical in HB16 mode for normal peripherals because there are generally not enough address bits available.	0x2-0x3	reserved
Value	Description											
0x0	ADMUX – AD[15:0] Data and Address are muxed.											
0x1	ADNONMUX – D[15:0] Data and address are separate. This mode is not practical in HB16 mode for normal peripherals because there are generally not enough address bits available.											
0x2-0x3	reserved											

Register 36: EPI Host-Bus 8 Configuration 4 (EPIHB8CFG4), offset 0x30C

Important: The `MODE` field in the `EPICFG` register determines which configuration is enabled.

For `EPIHB8CFG4` to be valid, the `MODE` field must be 0x2.

EPI Host-Bus 8 Configuration 4 (EPIHB8CFG4)

Base 0x400D.0000
 Offset 0x30C
 Type RW, reset 0x0008.0000

	31	30	29	28	27	26	25	24	23	22	21	20	19	18	17	16
	reserved										WRHIGH	RDHIGH	ALEHIGH	reserved		
Type	RO	RO	RO	RO	RO	RO	RO	RO	RO	RO	RW	RW	RW	RO	RO	RO
Reset	0	0	0	0	0	0	0	0	0	0	0	0	1	0	0	0
	15	14	13	12	11	10	9	8	7	6	5	4	3	2	1	0
	reserved								WRWS		RDWS		reserved		MODE	
Type	RO	RO	RO	RO	RO	RO	RO	RO	RW	RW	RW	RW	RO	RO	RW	RW
Reset	0	0	0	0	0	0	0	0	0	0	0	0	0	0	0	0

Bit/Field	Name	Type	Reset	Description
31:22	reserved	RO	0x0	Software should not rely on the value of a reserved bit. To provide compatibility with future products, the value of a reserved bit should be preserved across a read-modify-write operation.
21	WRHIGH	RW	0	CS3n WRITE Strobe Polarity This field is used if the <code>CSBAUD</code> bit is enabled in EPIHB8CFG2 . Value Description 0 The WRITE strobe for CS3n accesses is WRn (active Low). 1 The WRITE strobe for CS3n accesses is WR (active High).
20	RDHIGH	RW	0	CS2n READ Strobe Polarity This field is used if the <code>CSBAUD</code> bit is enabled in EPIHB8CFG2 . Value Description 0 The READ strobe for CS3n accesses is RDn (active Low). 1 The READ strobe for CS3n accesses is RD (active High).
19	ALEHIGH	RW	1	CS3n ALE Strobe Polarity This field is used if the <code>CSBAUD</code> bit is enabled in EPIHB8CFG2 . Value Description 0 The address latch strobe for CS3n accesses is ADVn (active Low). 1 The address latch strobe for CS3n accesses is ALE (active High).
18:8	reserved	RO	0x00	Software should not rely on the value of a reserved bit. To provide compatibility with future products, the value of a reserved bit should be preserved across a read-modify-write operation.

Bit/Field	Name	Type	Reset	Description
7:6	WRWS	RW	0x0	<p>CS3n Write Wait States</p> <p>This field adds wait states to the data phase of CS3n accesses (the address phase is not affected). The effect is to delay the rising edge of WRn (or the falling edge of WR). Each wait state adds 2 EPI clock cycles to the access time. The WRWSM bit in the EPIHB8TIME4 register can decrease the number of wait states by 1 EPI clock cycle for greater granularity. This field is used if the CSBAUD bit is enabled in the EPIHB8CFG2 register. This field is not applicable in BURST mode.</p> <p>Value Description</p> <p>0x0 Active WRn is 2 EPI clocks</p> <p>0x1 Active WRn is 4 EPI clocks</p> <p>0x2 Active WRn is 6 EPI clocks</p> <p>0x3 Active WRn is 8 EPI clocks</p> <p>This field is used in conjunction with the EPIBAUD2 register.</p>
5:4	RDWS	RW	0x0	<p>CS3n Read Wait States</p> <p>This field adds wait states to the data phase of CS3n accesses (the address phase is not affected).</p> <p>The effect is to delay the rising edge of RDn/Oen (or the falling edge of RD). Each wait state adds 2 EPI clock cycles to the access time. The RDWSM bit in the EPIHB8TIME4 register can decrease the number of wait states by 1 EPI clock cycle for greater granularity. This field is used when the CSBAUD bit is set in the EPIHB8CFG2 register.</p> <p>This field is not applicable in BURST mode.</p> <p>Value Description</p> <p>0x0 Active RDn is 2 EPI clocks</p> <p>0x1 Active RDn is 4 EPI clocks</p> <p>0x2 Active RDn is 6 EPI clocks</p> <p>0x3 Active RDn is 8 EPI clocks</p> <p>This field is used in conjunction with the EPIBAUD2 register.</p>
3:2	reserved	RO	0x0	<p>Software should not rely on the value of a reserved bit. To provide compatibility with future products, the value of a reserved bit should be preserved across a read-modify-write operation.</p>

Bit/Field	Name	Type	Reset	Description								
1:0	MODE	RW	0x0	<p>CS3n Host Bus Sub-Mode</p> <p>This field determines which Host Bus 8 sub-mode to use for CS3n in multiple chip select mode. Sub-mode use is determined by the connected external peripheral. See Table 11-8 on page 839 for information on how this bit field affects the operation of the EPI signals.</p> <p>Note: The CSBAUD bit must be set to enable this CS3n MODE field. If CSBAUD is clear, all chip-selects use the MODE configuration defined in the EPIHB8CFG register.</p> <table border="1"><thead><tr><th>Value</th><th>Description</th></tr></thead><tbody><tr><td>0x0</td><td>ADMUX – AD[7:0] Data and Address are muxed.</td></tr><tr><td>0x1</td><td>ADNONMUX – D[7:0] Data and address are separate.</td></tr><tr><td>0x2-0x3</td><td>reserved</td></tr></tbody></table>	Value	Description	0x0	ADMUX – AD[7:0] Data and Address are muxed.	0x1	ADNONMUX – D[7:0] Data and address are separate.	0x2-0x3	reserved
Value	Description											
0x0	ADMUX – AD[7:0] Data and Address are muxed.											
0x1	ADNONMUX – D[7:0] Data and address are separate.											
0x2-0x3	reserved											

Register 37: EPI Host-Bus 16 Configuration 4 (EPIHB16CFG4), offset 0x30C**Important:** The `MODE` field in the `EPICFG` register determines which configuration is enabled.For **EPIHB16CFG4** to be valid, the `MODE` field must be 0x3.

EPI Host-Bus 16 Configuration 4 (EPIHB16CFG4)

Base 0x400D.0000

Offset 0x30C

Type RW, reset 0x0008.0000

	31	30	29	28	27	26	25	24	23	22	21	20	19	18	17	16
	reserved										WRHIGH	RDHIGH	ALEHIGH	WRCRE	RDCRE	BURST
Type	RO	RO	RO	RO	RO	RO	RO	RO	RO	RO	RW	RW	RW	RW	RW	RW
Reset	0	0	0	0	0	0	0	0	0	0	0	0	1	0	0	0
	15	14	13	12	11	10	9	8	7	6	5	4	3	2	1	0
	reserved								WRWS		RDWS		reserved		MODE	
Type	RO	RO	RO	RO	RO	RO	RO	RO	RW	RW	RW	RW	RO	RO	RW	RW
Reset	0	0	0	0	0	0	0	0	0	0	0	0	0	0	0	0

Bit/Field	Name	Type	Reset	Description
31:22	reserved	RO	0x00	Software should not rely on the value of a reserved bit. To provide compatibility with future products, the value of a reserved bit should be preserved across a read-modify-write operation.
21	WRHIGH	RW	0	CS3n WRITE Strobe Polarity This field is used if the <code>CSBAUD</code> bit is enabled in EPIHB16CFG2 . Value Description 0 The WRITE strobe for CS3n accesses is WRn (active Low). 1 The WRITE strobe for CS3n accesses is WR (active High).
20	RDHIGH	RW	0	CS3n READ Strobe Polarity This field is used if the <code>CSBAUD</code> bit is enabled in EPIHB16CFG2 . Value Description 0 The READ strobe for CS3n accesses is RDn (active Low). 1 The READ strobe for CS3n accesses is RD (active High).
19	ALEHIGH	RW	1	CS3n ALE Strobe Polarity This field is used if the <code>CSBAUD</code> bit is enabled in EPIHB16CFG2 . Value Description 0 The address latch strobe for CS3n accesses is ADVn (active Low). 1 The address latch strobe for CS3n accesses is ALE (active High).

Bit/Field	Name	Type	Reset	Description
18	WRCRE	RW	0	<p>CS3n PSRAM Configuration Register Write Used for PSRAM configuration registers.</p> <p>With <code>WRCRE</code> set, the next transaction by the EPI will be a write of the <code>CR</code> bit field in the EPIHBPSRAM register to the configuration register (CR) of the PSRAM. The <code>WRCRE</code> bit will self clear once the write-enabled CRE access is complete.</p> <p>Value Description</p> <p>0 No Action.</p> <p>1 Start CRE write transaction for CS3n.</p>
17	RDCRE	RW	0	<p>CS3n PSRAM Configuration Register Read Used for PSRAM configuration registers.</p> <p>With the <code>RDCRE</code> set, the next access is a read of the PSRAM's Configuration Register (CR). This bit self clears once the CRE access is complete. The address for the CRE access is located at EPIHBPSRAM[19:18]. The read data is returned on EPIHBPSRAM[15:0].</p> <p>Value Description</p> <p>0 No Action.</p> <p>1 Start CRE read transaction for CS3n.</p>
16	BURST	RW	0	<p>CS3n Burst Mode</p> <p>Burst mode must be used with an ALE, which is configured by programming the <code>CSCFG</code> and <code>CSCFGEXT</code> fields in the EPIHB16CFG2 register. Burst mode must be used in ADMUX, which is set by the <code>MODE</code> field in EPIHB16CFG4.</p> <p>Note: Burst mode is optimized for word-length accesses.</p> <p>Value Description</p> <p>0 Burst mode is disabled.</p> <p>1 Burst mode is enabled for CS3n.</p>
15:8	reserved	RO	0x00	<p>Software should not rely on the value of a reserved bit. To provide compatibility with future products, the value of a reserved bit should be preserved across a read-modify-write operation.</p>

Bit/Field	Name	Type	Reset	Description
7:6	WRWS	RW	0x0	<p>CS3n Write Wait States</p> <p>This field adds wait states to the data phase of CS2n accesses (the address phase is not affected).</p> <p>The effect is to delay the rising edge of WRn (or the falling edge of WR). Each wait state adds 2 EPI clock cycles to the access time. The WRWSM bit in the EPIHB16TIME4 register can decrease the number of wait states by 1 EPI clock cycle for greater granularity. This field is used if the CSBAUD bit is set in the EPIHB16CFG2 register. This field is not applicable in BURST mode.</p> <p>Value Description</p> <p>0x0 Active WRn is 2 EPI clocks</p> <p>0x1 Active WRn is 4 EPI clocks</p> <p>0x2 Active WRn is 6 EPI clocks</p> <p>0x3 Active WRn is 8 EPI clocks</p> <p>This field is used in conjunction with the EPIBAUD2 register.</p>
5:4	RDWS	RW	0x0	<p>CS3n Read Wait States</p> <p>This field adds wait states to the data phase of CS3n accesses (the address phase is not affected).</p> <p>The effect is to delay the rising edge of RDn/Oen (or the falling edge of RD). Each wait state adds 2 EPI clock cycles to the access time. The RDWSM bit in the EPIHB16TIME4 register can decrease the number of wait states by 1 EPI clock cycle for greater granularity. This field is used when the CSBAUD bit is set in the EPIHB16CFG2 register.</p> <p>This field is not applicable in BURST mode.</p> <p>Value Description</p> <p>0x0 Active RDn is 2 EPI clocks</p> <p>0x1 Active RDn is 4 EPI clocks</p> <p>0x2 Active RDn is 6 EPI clocks</p> <p>0x3 Active RDn is 8 EPI clocks</p> <p>This field is used in conjunction with the EPIBAUD2 register.</p>
3:2	reserved	RO	0	<p>Software should not rely on the value of a reserved bit. To provide compatibility with future products, the value of a reserved bit should be preserved across a read-modify-write operation.</p>

Bit/Field	Name	Type	Reset	Description								
1:0	MODE	RW	0x0	<p>CS3n Host Bus Sub-Mode</p> <p>This field determines which Host Bus 16 sub-mode to use for CS3n in multiple chip select mode.</p> <p>Sub-mode use is determined by the connected external peripheral. See Table 11-9 on page 841 for information on how this bit field affects the operation of the EPI signals.</p> <p>Note: The CSBAUD bit must be set to enable this CS3n MODE field. If CSBAUD is clear, all chip-selects use the MODE configuration defined in the EPIHB16CFG register.</p> <table border="1"> <thead> <tr> <th>Value</th> <th>Description</th> </tr> </thead> <tbody> <tr> <td>0x0</td> <td> ADMUX – AD[15:0] Data and Address are muxed. </td> </tr> <tr> <td>0x1</td> <td> ADNONMUX – D[15:0] Data and address are separate. This mode is not practical in HB16 mode for normal peripherals because there are generally not enough address bits available. </td> </tr> <tr> <td>0x2-0x3</td> <td>reserved</td> </tr> </tbody> </table>	Value	Description	0x0	ADMUX – AD[15:0] Data and Address are muxed.	0x1	ADNONMUX – D[15:0] Data and address are separate. This mode is not practical in HB16 mode for normal peripherals because there are generally not enough address bits available.	0x2-0x3	reserved
Value	Description											
0x0	ADMUX – AD[15:0] Data and Address are muxed.											
0x1	ADNONMUX – D[15:0] Data and address are separate. This mode is not practical in HB16 mode for normal peripherals because there are generally not enough address bits available.											
0x2-0x3	reserved											

Register 38: EPI Host-Bus 8 Timing Extension (EPIHB8TIME), offset 0x310**Important:** The `MODE` field in the `EPICFG` register determines which configuration is enabled.For `EPIHB8TIME` to be valid, the `MODE` field must be 0x2.

EPI Host-Bus 8 Timing Extension (EPIHB8TIME)

Base 0x400D.0000

Offset 0x310

Type RW, reset 0x0002.2000

	31	30	29	28	27	26	25	24	23	22	21	20	19	18	17	16
	reserved						IRDYDLY		reserved							
Type	RO	RO	RO	RO	RO	RO	RW	RW	RO	RO	RO	RO	RO	RO	RO	RO
Reset	0	0	0	0	0	0	0	0	0	0	0	0	0	0	1	0
	15	14	13	12	11	10	9	8	7	6	5	4	3	2	1	0
	reserved		CAPWIDTH		reserved							WRWSM	reserved			RDWSM
Type	RO	RO	RW	RW	RO	RO	RO	RO	RO	RO	RO	RW	RO	RO	RO	RW
Reset	0	0	1	0	0	0	0	0	0	0	0	0	0	0	0	0

Bit/Field	Name	Type	Reset	Description
31:26	reserved	RO	0x00	Software should not rely on the value of a reserved bit. To provide compatibility with future products, the value of a reserved bit should be preserved across a read-modify-write operation.
25:24	IRDYDLY	RW	0x0	CS0n Input Ready Delay Value Description 0 reserved 1 Stall begins one EPI clocks past iRDY low being sampled on the rising edge of EPIO clock. 2 Stall begins two EPI clocks past iRDY low being sampled on the rising edge of EPIO clock. 3 Stall begins three EPI clocks past iRDY low being sampled on the rising edge of EPIO clock.
23:14	reserved	RO	0x008	Software should not rely on the value of a reserved bit. To provide compatibility with future products, the value of a reserved bit should be preserved across a read-modify-write operation.
13:12	CAPWIDTH	RW	0x2	CS0n Inter-transfer Capture Width Controls the delay between Host-Bus transfers. Value Description 0x0 Reserved 0x1 1 EPI clock. 0x2 2 EPI clock. 0x3 Reserved
11:5	reserved	RO	0x00	Software should not rely on the value of a reserved bit. To provide compatibility with future products, the value of a reserved bit should be preserved across a read-modify-write operation.

Bit/Field	Name	Type	Reset	Description
4	WRWSM	RW	0	<p>Write Wait State Minus One</p> <p>This bit is used with the <code>WRWS</code> field in EPIHB8CFG. This field is not applicable in BURST mode.</p> <p>Value Description</p> <p>0 No change in the number of wait state clock cycles programmed in the in <code>WRWS</code> field in EPIHB8CFG register.</p> <p>1 Wait state value is now: <code>WRWS - 1</code> <code>WRWS</code> field is programmed in EPIHB8CFG.</p>
3:1	reserved	RO	0x0	<p>Software should not rely on the value of a reserved bit. To provide compatibility with future products, the value of a reserved bit should be preserved across a read-modify-write operation.</p>
0	RDWSM	RW	0	<p>Read Wait State Minus One</p> <p>Use with <code>RDWS</code> field in the EPIHB8CFG register. This field is not applicable in BURST mode.</p> <p>Value Description</p> <p>0 No change in the number of wait state clock cycles programmed in the <code>RDWS</code> field of EPIHB8CFG.</p> <p>1 Wait state value is now: <code>RDWS - 1</code> <code>RDWS</code> field is programmed in EPIHB8CFG.</p>

Register 39: EPI Host-Bus 16 Timing Extension (EPIHB16TIME), offset 0x310**Important:** The `MODE` field in the `EPICFG` register determines which configuration is enabled.For `EPIHB16TIME` to be valid, the `MODE` field must be 0x3.

EPI Host-Bus 16 Timing Extension (EPIHB16TIME)

Base 0x400D.0000

Offset 0x310

Type RW, reset 0x0002.2000

	31	30	29	28	27	26	25	24	23	22	21	20	19	18	17	16
	reserved						IRDYDLY		reserved						PSRAMSZ	
Type	RO	RO	RO	RO	RO	RO	RW	RW	RO	RO	RO	RO	RO	RW	RW	RW
Reset	0	0	0	0	0	0	0	0	0	0	0	0	0	0	1	0
	15	14	13	12	11	10	9	8	7	6	5	4	3	2	1	0
	reserved		CAPWIDTH		reserved						WRWSM		reserved		RDWSM	
Type	RO	RO	RW	RW	RO	RO	RO	RO	RO	RO	RO	RW	RO	RO	RO	RW
Reset	0	0	1	0	0	0	0	0	0	0	0	0	0	0	0	0

Bit/Field	Name	Type	Reset	Description																		
31:26	reserved	RO	0x00	Software should not rely on the value of a reserved bit. To provide compatibility with future products, the value of a reserved bit should be preserved across a read-modify-write operation.																		
25:24	IRDYDLY	RW	0x0	CS0n Input Ready Delay <table border="0"> <tr> <td>Value</td> <td>Description</td> </tr> <tr> <td>0</td> <td>reserved</td> </tr> <tr> <td>1</td> <td>Stall begins one EPI clocks past iRDY low being sampled on the rising edge of EPIO clock.</td> </tr> <tr> <td>2</td> <td>Stall begins two EPI clocks past iRDY low being sampled on the rising edge of EPIO clock.</td> </tr> <tr> <td>3</td> <td>Stall begins three EPI clocks past iRDY low being sampled on the rising edge of EPIO clock.</td> </tr> </table>	Value	Description	0	reserved	1	Stall begins one EPI clocks past iRDY low being sampled on the rising edge of EPIO clock.	2	Stall begins two EPI clocks past iRDY low being sampled on the rising edge of EPIO clock.	3	Stall begins three EPI clocks past iRDY low being sampled on the rising edge of EPIO clock.								
Value	Description																					
0	reserved																					
1	Stall begins one EPI clocks past iRDY low being sampled on the rising edge of EPIO clock.																					
2	Stall begins two EPI clocks past iRDY low being sampled on the rising edge of EPIO clock.																					
3	Stall begins three EPI clocks past iRDY low being sampled on the rising edge of EPIO clock.																					
23:19	reserved	RO	0x000	Software should not rely on the value of a reserved bit. To provide compatibility with future products, the value of a reserved bit should be preserved across a read-modify-write operation.																		
18:16	PSRAMSZ	RW	0x2	PSRAM Row Size Defines the row size for the PSRAM controlled by CS0n <table border="0"> <tr> <td>Value</td> <td>Description</td> </tr> <tr> <td>0x0</td> <td>No row size limitation</td> </tr> <tr> <td>0x1</td> <td>128 B</td> </tr> <tr> <td>0x2</td> <td>256 B</td> </tr> <tr> <td>0x3</td> <td>512 B</td> </tr> <tr> <td>0x4</td> <td>1024 B</td> </tr> <tr> <td>0x5</td> <td>2048 B</td> </tr> <tr> <td>0x6</td> <td>4096 B</td> </tr> <tr> <td>0x7</td> <td>8192 B</td> </tr> </table>	Value	Description	0x0	No row size limitation	0x1	128 B	0x2	256 B	0x3	512 B	0x4	1024 B	0x5	2048 B	0x6	4096 B	0x7	8192 B
Value	Description																					
0x0	No row size limitation																					
0x1	128 B																					
0x2	256 B																					
0x3	512 B																					
0x4	1024 B																					
0x5	2048 B																					
0x6	4096 B																					
0x7	8192 B																					

Bit/Field	Name	Type	Reset	Description
15:14	reserved	RO	0x0	Software should not rely on the value of a reserved bit. To provide compatibility with future products, the value of a reserved bit should be preserved across a read-modify-write operation.
13:12	CAPWIDTH	RW	0x2	CS0n Inter-transfer Capture Width Controls the delay between Host-Bus transfers. Value Description 0x0 Reserved 0x1 1 EPI clock. 0x2 2 EPI clock. 0x3 Reserved
11:5	reserved	RO	0x0	Software should not rely on the value of a reserved bit. To provide compatibility with future products, the value of a reserved bit should be preserved across a read-modify-write operation.
4	WRWSM	RW	0	Write Wait State Minus One This bit is used with the WRWS field in EPIHB16CFG . This field is not applicable in BURST mode. Value Description 0 No change in the number of wait state clock cycles programmed in the in WRWS field in EPIHB16CFG register. 1 Wait state value is now: WRWS - 1 WRWS field is programmed in EPIHB16CFG .
3:1	reserved	RO	0x0	Software should not rely on the value of a reserved bit. To provide compatibility with future products, the value of a reserved bit should be preserved across a read-modify-write operation.
0	RDWSM	RW	0	Read Wait State Minus One Use with RDWS field in the EPIHB16CFG register. This field is not applicable in BURST mode. Value Description 0 No change in the number of wait state clock cycles programmed in the RDWS field of EPIHB16CFG . 1 Wait state value is now: RDWS - 1 RDWS field is programmed in EPIHB16CFG .

Register 40: EPI Host-Bus 8 Timing Extension (EPIHB8TIME2), offset 0x314**Important:** The `MODE` field in the `EPICFG` register determines which configuration is enabled.For `EPIHB8TIME2` to be valid, the `MODE` field must be 0x2.

EPI Host-Bus 8 Timing Extension (EPIHB8TIME2)

Base 0x400D.0000

Offset 0x314

Type RW, reset 0x0002.2000

	31	30	29	28	27	26	25	24	23	22	21	20	19	18	17	16
	reserved						IRDYDLY		reserved							
Type	RO	RO	RO	RO	RO	RO	RW	RW	RO	RO	RO	RO	RO	RO	RO	RO
Reset	0	0	0	0	0	0	0	0	0	0	0	0	0	0	0	0
	15	14	13	12	11	10	9	8	7	6	5	4	3	2	1	0
	reserved		CAPWIDTH		reserved							WRWSM	reserved			RDWSM
Type	RO	RO	RW	RW	RO	RO	RO	RO	RO	RO	RO	RW	RO	RO	RO	RW
Reset	1	0	1	0	0	0	0	0	0	0	0	0	0	0	0	0

Bit/Field	Name	Type	Reset	Description										
31:26	reserved	RO	0x00	Software should not rely on the value of a reserved bit. To provide compatibility with future products, the value of a reserved bit should be preserved across a read-modify-write operation.										
25:24	IRDYDLY	RW	0x0	CS1n Input Ready Delay <table border="0"> <tr> <td>Value</td> <td>Description</td> </tr> <tr> <td>0</td> <td>reserved</td> </tr> <tr> <td>1</td> <td>Stall begins one EPI clocks past iRDY low being sampled on the rising edge of EPIO clock.</td> </tr> <tr> <td>2</td> <td>Stall begins two EPI clocks past iRDY low being sampled on the rising edge of EPIO clock.</td> </tr> <tr> <td>3</td> <td>Stall begins three EPI clocks past iRDY low being sampled on the rising edge of EPIO clock.</td> </tr> </table>	Value	Description	0	reserved	1	Stall begins one EPI clocks past iRDY low being sampled on the rising edge of EPIO clock.	2	Stall begins two EPI clocks past iRDY low being sampled on the rising edge of EPIO clock.	3	Stall begins three EPI clocks past iRDY low being sampled on the rising edge of EPIO clock.
Value	Description													
0	reserved													
1	Stall begins one EPI clocks past iRDY low being sampled on the rising edge of EPIO clock.													
2	Stall begins two EPI clocks past iRDY low being sampled on the rising edge of EPIO clock.													
3	Stall begins three EPI clocks past iRDY low being sampled on the rising edge of EPIO clock.													
23:14	reserved	RO	0x002	Software should not rely on the value of a reserved bit. To provide compatibility with future products, the value of a reserved bit should be preserved across a read-modify-write operation.										
13:12	CAPWIDTH	RW	0x2	CS1n Inter-transfer Capture Width Controls the delay between Host-Bus transfers. <table border="0"> <tr> <td>Value</td> <td>Description</td> </tr> <tr> <td>0x0</td> <td>Reserved</td> </tr> <tr> <td>0x1</td> <td>1 EPI clock.</td> </tr> <tr> <td>0x2</td> <td>2 EPI clock.</td> </tr> <tr> <td>0x3</td> <td>Reserved</td> </tr> </table>	Value	Description	0x0	Reserved	0x1	1 EPI clock.	0x2	2 EPI clock.	0x3	Reserved
Value	Description													
0x0	Reserved													
0x1	1 EPI clock.													
0x2	2 EPI clock.													
0x3	Reserved													
11:5	reserved	RO	0x00	Software should not rely on the value of a reserved bit. To provide compatibility with future products, the value of a reserved bit should be preserved across a read-modify-write operation.										

Bit/Field	Name	Type	Reset	Description
4	WRWSM	RW	0	<p>CS1n Write Wait State Minus One</p> <p>This bit is used with the <code>WRWS</code> field in EPIHB8CFG2. This field is not applicable in BURST mode.</p> <p>Value Description</p> <p>0 No change in the number of wait state clock cycles programmed in the in <code>WRWS</code> field in EPIHB8CFG2 register.</p> <p>1 Wait state value is now: <code>WRWS - 1</code> <code>WRWS</code> field is programmed in EPIHB8CFG2.</p>
3:1	reserved	RO	0x0	<p>Software should not rely on the value of a reserved bit. To provide compatibility with future products, the value of a reserved bit should be preserved across a read-modify-write operation.</p>
0	RDWSM	RW	0	<p>CS1n Read Wait State Minus One</p> <p>This field is used with <code>RDWS</code> field in EPIHB8CFG2. This bit is not applicable in BURST mode.</p> <p>Value Description</p> <p>0 No change in the number of wait state clock cycles programmed in the <code>RDWS</code> field of EPIHB8CFG2.</p> <p>1 Wait state value is now: <code>RDWS - 1</code> <code>RDWS</code> field is programmed in EPIHB8CFG2.</p>

Register 41: EPI Host-Bus 16 Timing Extension (EPIHB16TIME2), offset 0x314

Important: The `MODE` field in the `EPICFG` register determines which configuration is enabled.

For `EPIHB16TIME2` to be valid, the `MODE` field must be 0x3.

EPI Host-Bus 16 Timing Extension (EPIHB16TIME2)

Base 0x400D.0000

Offset 0x314

Type RW, reset 0x0002.2000

	31	30	29	28	27	26	25	24	23	22	21	20	19	18	17	16
	reserved						IRDYDLY		reserved						PSRAMSZ	
Type	RO	RO	RO	RO	RO	RO	RW	RW	RO	RO	RO	RO	RO	RW	RW	RW
Reset	0	0	0	0	0	0	0	0	0	0	0	0	0	0	1	0
	15	14	13	12	11	10	9	8	7	6	5	4	3	2	1	0
	reserved		CAPWIDTH		reserved						WRWSM		reserved		RDWSM	
Type	RO	RO	RW	RW	RO	RO	RO	RO	RO	RO	RO	RW	RO	RO	RO	RW
Reset	0	0	1	0	0	0	0	0	0	0	0	0	0	0	0	0

Bit/Field	Name	Type	Reset	Description																		
31:26	reserved	RO	0x00	Software should not rely on the value of a reserved bit. To provide compatibility with future products, the value of a reserved bit should be preserved across a read-modify-write operation.																		
25:24	IRDYDLY	RW	0x0	CS1n Input Ready Delay <table border="1"> <thead> <tr> <th>Value</th> <th>Description</th> </tr> </thead> <tbody> <tr> <td>0</td> <td>reserved</td> </tr> <tr> <td>1</td> <td>Stall begins one EPI clocks past iRDY low being sampled on the rising edge of EPIO clock.</td> </tr> <tr> <td>2</td> <td>Stall begins two EPI clocks past iRDY low being sampled on the rising edge of EPIO clock.</td> </tr> <tr> <td>3</td> <td>Stall begins three EPI clocks past iRDY low being sampled on the rising edge of EPIO clock.</td> </tr> </tbody> </table>	Value	Description	0	reserved	1	Stall begins one EPI clocks past iRDY low being sampled on the rising edge of EPIO clock.	2	Stall begins two EPI clocks past iRDY low being sampled on the rising edge of EPIO clock.	3	Stall begins three EPI clocks past iRDY low being sampled on the rising edge of EPIO clock.								
Value	Description																					
0	reserved																					
1	Stall begins one EPI clocks past iRDY low being sampled on the rising edge of EPIO clock.																					
2	Stall begins two EPI clocks past iRDY low being sampled on the rising edge of EPIO clock.																					
3	Stall begins three EPI clocks past iRDY low being sampled on the rising edge of EPIO clock.																					
23:19	reserved	RO	0x000	Software should not rely on the value of a reserved bit. To provide compatibility with future products, the value of a reserved bit should be preserved across a read-modify-write operation.																		
18:16	PSRAMSZ	RW	0x2	PSRAM Row Size Defines the row size for the PSRAM controlled by CS1n <table border="1"> <thead> <tr> <th>Value</th> <th>Description</th> </tr> </thead> <tbody> <tr> <td>0x0</td> <td>No row size limitation</td> </tr> <tr> <td>0x1</td> <td>128 B</td> </tr> <tr> <td>0x2</td> <td>256 B</td> </tr> <tr> <td>0x3</td> <td>512 B</td> </tr> <tr> <td>0x4</td> <td>1024 B</td> </tr> <tr> <td>0x5</td> <td>2048 B</td> </tr> <tr> <td>0x6</td> <td>4096 B</td> </tr> <tr> <td>0x7</td> <td>8192 B</td> </tr> </tbody> </table>	Value	Description	0x0	No row size limitation	0x1	128 B	0x2	256 B	0x3	512 B	0x4	1024 B	0x5	2048 B	0x6	4096 B	0x7	8192 B
Value	Description																					
0x0	No row size limitation																					
0x1	128 B																					
0x2	256 B																					
0x3	512 B																					
0x4	1024 B																					
0x5	2048 B																					
0x6	4096 B																					
0x7	8192 B																					

Bit/Field	Name	Type	Reset	Description
15:14	reserved	RO	0x0	Software should not rely on the value of a reserved bit. To provide compatibility with future products, the value of a reserved bit should be preserved across a read-modify-write operation.
13:12	CAPWIDTH	RW	0x2	<p>CS1n Inter-transfer Capture Width Controls the delay between Host-Bus transfers.</p> <p>Value Description</p> <p>0x0 Reserved</p> <p>0x1 1 EPI clock.</p> <p>0x2 2 EPI clock.</p> <p>0x3 Reserved</p>
11:5	reserved	RO	0x00	Software should not rely on the value of a reserved bit. To provide compatibility with future products, the value of a reserved bit should be preserved across a read-modify-write operation.
4	WRWSM	RW	0	<p>CS1n Write Wait State Minus One This bit is used with the WRWS field in EPIHB16CFG2. This field is not applicable in BURST mode..</p> <p>Value Description</p> <p>0 No change in the number of wait state clock cycles programmed in the in WRWS field in EPIHB16CFG2 register.</p> <p>1 Wait state value is now: WRWS - 1 WRWS field is programmed in EPIHB16CFG2.</p>
3:1	reserved	RO	0x0	Software should not rely on the value of a reserved bit. To provide compatibility with future products, the value of a reserved bit should be preserved across a read-modify-write operation.
0	RDWSM	RW	0	<p>CS1n Read Wait State Minus One This field is used with RDWS field in EPIHB16CFG2. This bit is not applicable in BURST mode.</p> <p>Value Description</p> <p>0 No change in the number of wait state clock cycles programmed in the RDWS field of EPIHB16CFG2.</p> <p>1 Wait state value is now: RDWS - 1 RDWS field is programmed in EPIHB16CFG2.</p>

Register 42: EPI Host-Bus 8 Timing Extension (EPIHB8TIME3), offset 0x318**Important:** The `MODE` field in the `EPICFG` register determines which configuration is enabled.For `EPIHB8TIME3` to be valid, the `MODE` field must be 0x2.

EPI Host-Bus 8 Timing Extension (EPIHB8TIME3)

Base 0x400D.0000

Offset 0x318

Type RW, reset 0x0002.2000

	31	30	29	28	27	26	25	24	23	22	21	20	19	18	17	16
	reserved						IRDYDLY		reserved							
Type	RO	RO	RO	RO	RO	RO	RW	RW	RO	RO	RO	RO	RO	RO	RO	RO
Reset	0	0	0	0	0	0	0	0	0	0	0	0	0	0	0	0
	15	14	13	12	11	10	9	8	7	6	5	4	3	2	1	0
	reserved		CAPWIDTH		reserved							WRWSM	reserved			RDWSM
Type	RO	RO	RW	RW	RO	RO	RO	RO	RO	RO	RO	RW	RO	RO	RO	RW
Reset	1	0	1	0	0	0	0	0	0	0	0	0	0	0	0	0

Bit/Field	Name	Type	Reset	Description										
31:26	reserved	RO	0x00	Software should not rely on the value of a reserved bit. To provide compatibility with future products, the value of a reserved bit should be preserved across a read-modify-write operation.										
25:24	IRDYDLY	RW	0x0	CS2n Input Ready Delay <table border="0"> <tr> <td>Value</td> <td>Description</td> </tr> <tr> <td>0</td> <td>reserved</td> </tr> <tr> <td>1</td> <td>Stall begins one EPI clocks past iRDY low being sampled on the rising edge of EPIO clock.</td> </tr> <tr> <td>2</td> <td>Stall begins two EPI clocks past iRDY low being sampled on the rising edge of EPIO clock.</td> </tr> <tr> <td>3</td> <td>Stall begins three EPI clocks past iRDY low being sampled on the rising edge of EPIO clock.</td> </tr> </table>	Value	Description	0	reserved	1	Stall begins one EPI clocks past iRDY low being sampled on the rising edge of EPIO clock.	2	Stall begins two EPI clocks past iRDY low being sampled on the rising edge of EPIO clock.	3	Stall begins three EPI clocks past iRDY low being sampled on the rising edge of EPIO clock.
Value	Description													
0	reserved													
1	Stall begins one EPI clocks past iRDY low being sampled on the rising edge of EPIO clock.													
2	Stall begins two EPI clocks past iRDY low being sampled on the rising edge of EPIO clock.													
3	Stall begins three EPI clocks past iRDY low being sampled on the rising edge of EPIO clock.													
23:14	reserved	RO	0x002	Software should not rely on the value of a reserved bit. To provide compatibility with future products, the value of a reserved bit should be preserved across a read-modify-write operation.										
13:12	CAPWIDTH	RW	0x2	CS2n Inter-transfer Capture Width Controls the delay between Host-Bus transfers. <table border="0"> <tr> <td>Value</td> <td>Description</td> </tr> <tr> <td>0x0</td> <td>Reserved</td> </tr> <tr> <td>0x1</td> <td>1 EPI clock.</td> </tr> <tr> <td>0x2</td> <td>2 EPI clock.</td> </tr> <tr> <td>0x3</td> <td>Reserved</td> </tr> </table>	Value	Description	0x0	Reserved	0x1	1 EPI clock.	0x2	2 EPI clock.	0x3	Reserved
Value	Description													
0x0	Reserved													
0x1	1 EPI clock.													
0x2	2 EPI clock.													
0x3	Reserved													
11:5	reserved	RO	0x00	Software should not rely on the value of a reserved bit. To provide compatibility with future products, the value of a reserved bit should be preserved across a read-modify-write operation.										

Bit/Field	Name	Type	Reset	Description
4	WRWSM	RW	0	<p>CS2n Write Wait State Minus One</p> <p>This bit is used with the <code>WRWS</code> field in EPIHB8CFG3. This field is not applicable in BURST mode.</p> <p>Value Description</p> <p>0 No change in the number of wait state clock cycles programmed in the in <code>WRWS</code> field in EPIHB8CFG3 register.</p> <p>1 Wait state value is now: <code>WRWS - 1</code> <code>WRWS</code> field is programmed in EPIHB8CFG3.</p>
3:1	reserved	RO	0x0	<p>Software should not rely on the value of a reserved bit. To provide compatibility with future products, the value of a reserved bit should be preserved across a read-modify-write operation.</p>
0	RDWSM	RW	0	<p>CS2n Read Wait State Minus One</p> <p>This field is used with <code>RDWS</code> field in EPIHB8CFG3. This bit is not applicable in BURST mode.</p> <p>Value Description</p> <p>0 No change in the number of wait state clock cycles programmed in the <code>RDWS</code> field of EPIHB8CFG3.</p> <p>1 Wait state value is now: <code>RDWS - 1</code> <code>RDWS</code> field is programmed in EPIHB8CFG3.</p>

Register 43: EPI Host-Bus 16 Timing Extension (EPIHB16TIME3), offset 0x318

Important: The `MODE` field in the `EPICFG` register determines which configuration is enabled.

For `EPIHB16TIME3` to be valid, the `MODE` field must be 0x3.

EPI Host-Bus 16 Timing Extension (EPIHB16TIME3)

Base 0x400D.0000

Offset 0x318

Type RW, reset 0x0002.2000

	31	30	29	28	27	26	25	24	23	22	21	20	19	18	17	16
	reserved						IRDYDLY		reserved						PSRAMSZ	
Type	RO	RO	RO	RO	RO	RO	RW	RW	RO	RO	RO	RO	RO	RW	RW	RW
Reset	0	0	0	0	0	0	0	0	0	0	0	0	0	0	1	0
	15	14	13	12	11	10	9	8	7	6	5	4	3	2	1	0
	reserved		CAPWIDTH		reserved						WRWSM		reserved		RDWSM	
Type	RO	RO	RW	RW	RO	RO	RO	RO	RO	RO	RO	RW	RO	RO	RO	RW
Reset	0	0	1	0	0	0	0	0	0	0	0	0	0	0	0	0

Bit/Field	Name	Type	Reset	Description																		
31:26	reserved	RO	0x00	Software should not rely on the value of a reserved bit. To provide compatibility with future products, the value of a reserved bit should be preserved across a read-modify-write operation.																		
25:24	IRDYDLY	RW	0x0	CS2n Input Ready Delay <table border="0"> <tr> <td>Value</td> <td>Description</td> </tr> <tr> <td>0</td> <td>reserved</td> </tr> <tr> <td>1</td> <td>Stall begins one EPI clocks past iRDY low being sampled on the rising edge of EPIO clock.</td> </tr> <tr> <td>2</td> <td>Stall begins two EPI clocks past iRDY low being sampled on the rising edge of EPIO clock.</td> </tr> <tr> <td>3</td> <td>Stall begins three EPI clocks past iRDY low being sampled on the rising edge of EPIO clock.</td> </tr> </table>	Value	Description	0	reserved	1	Stall begins one EPI clocks past iRDY low being sampled on the rising edge of EPIO clock.	2	Stall begins two EPI clocks past iRDY low being sampled on the rising edge of EPIO clock.	3	Stall begins three EPI clocks past iRDY low being sampled on the rising edge of EPIO clock.								
Value	Description																					
0	reserved																					
1	Stall begins one EPI clocks past iRDY low being sampled on the rising edge of EPIO clock.																					
2	Stall begins two EPI clocks past iRDY low being sampled on the rising edge of EPIO clock.																					
3	Stall begins three EPI clocks past iRDY low being sampled on the rising edge of EPIO clock.																					
23:19	reserved	RO	0x000	Software should not rely on the value of a reserved bit. To provide compatibility with future products, the value of a reserved bit should be preserved across a read-modify-write operation.																		
18:16	PSRAMSZ	RW	0x2	PSRAM Row Size Defines the row size for the PSRAM controlled by CS2n <table border="0"> <tr> <td>Value</td> <td>Description</td> </tr> <tr> <td>0x0</td> <td>No row size limitation</td> </tr> <tr> <td>0x1</td> <td>128 B</td> </tr> <tr> <td>0x2</td> <td>256 B</td> </tr> <tr> <td>0x3</td> <td>512 B</td> </tr> <tr> <td>0x4</td> <td>1024 B</td> </tr> <tr> <td>0x5</td> <td>2048 B</td> </tr> <tr> <td>0x6</td> <td>4096 B</td> </tr> <tr> <td>0x7</td> <td>8192 B</td> </tr> </table>	Value	Description	0x0	No row size limitation	0x1	128 B	0x2	256 B	0x3	512 B	0x4	1024 B	0x5	2048 B	0x6	4096 B	0x7	8192 B
Value	Description																					
0x0	No row size limitation																					
0x1	128 B																					
0x2	256 B																					
0x3	512 B																					
0x4	1024 B																					
0x5	2048 B																					
0x6	4096 B																					
0x7	8192 B																					

Bit/Field	Name	Type	Reset	Description								
15:14	reserved	RO	0x0	Software should not rely on the value of a reserved bit. To provide compatibility with future products, the value of a reserved bit should be preserved across a read-modify-write operation.								
13:12	CAPWIDTH	RW	0x2	<p>CS2n Inter-transfer Capture Width Controls the delay between Host-Bus transfers.</p> <p>Value Description</p> <table border="1"> <tr> <td>0x0</td> <td>Reserved</td> </tr> <tr> <td>0x1</td> <td>1 EPI clock.</td> </tr> <tr> <td>0x2</td> <td>2 EPI clock.</td> </tr> <tr> <td>0x3</td> <td>Reserved</td> </tr> </table>	0x0	Reserved	0x1	1 EPI clock.	0x2	2 EPI clock.	0x3	Reserved
0x0	Reserved											
0x1	1 EPI clock.											
0x2	2 EPI clock.											
0x3	Reserved											
11:5	reserved	RO	0x00	Software should not rely on the value of a reserved bit. To provide compatibility with future products, the value of a reserved bit should be preserved across a read-modify-write operation.								
4	WRWSM	RW	0	<p>CS2n Write Wait State Minus One This bit is used with the WRWS field in EPIHB16CFG3. This field is not applicable in BURST mode.</p> <p>Value Description</p> <table border="1"> <tr> <td>0</td> <td>No change in the number of wait state clock cycles programmed in the in WRWS field in EPIHB16CFG3 register.</td> </tr> <tr> <td>1</td> <td>Wait state value is now: WRWS - 1 WRWS field is programmed in EPIHB16CFG3.</td> </tr> </table>	0	No change in the number of wait state clock cycles programmed in the in WRWS field in EPIHB16CFG3 register.	1	Wait state value is now: WRWS - 1 WRWS field is programmed in EPIHB16CFG3 .				
0	No change in the number of wait state clock cycles programmed in the in WRWS field in EPIHB16CFG3 register.											
1	Wait state value is now: WRWS - 1 WRWS field is programmed in EPIHB16CFG3 .											
3:1	reserved	RO	0x0	Software should not rely on the value of a reserved bit. To provide compatibility with future products, the value of a reserved bit should be preserved across a read-modify-write operation.								
0	RDWSM	RW	0	<p>CS2n Read Wait State Minus One This field is used with RDWS field in EPIHB16CFG3. This bit is not applicable in BURST mode.</p> <p>Value Description</p> <table border="1"> <tr> <td>0</td> <td>No change in the number of wait state clock cycles programmed in the RDWS field of EPIHB16CFG3.</td> </tr> <tr> <td>1</td> <td>Wait state value is now: RDWS - 1 RDWS field is programmed in EPIHB16CFG3.</td> </tr> </table>	0	No change in the number of wait state clock cycles programmed in the RDWS field of EPIHB16CFG3 .	1	Wait state value is now: RDWS - 1 RDWS field is programmed in EPIHB16CFG3 .				
0	No change in the number of wait state clock cycles programmed in the RDWS field of EPIHB16CFG3 .											
1	Wait state value is now: RDWS - 1 RDWS field is programmed in EPIHB16CFG3 .											

Register 44: EPI Host-Bus 8 Timing Extension (EPIHB8TIME4), offset 0x31C

Important: The `MODE` field in the `EPICFG` register determines which configuration is enabled.

For `EPIHB8TIME4` to be valid, the `MODE` field must be 0x2.

EPI Host-Bus 8 Timing Extension (EPIHB8TIME4)

Base 0x400D.0000

Offset 0x31C

Type RW, reset 0x0002.2000

	31	30	29	28	27	26	25	24	23	22	21	20	19	18	17	16
	reserved						IRDYDLY		reserved							
Type	RO	RO	RO	RO	RO	RO	RW	RW	RO	RO	RO	RO	RO	RO	RO	RO
Reset	0	0	0	0	0	0	0	0	0	0	0	0	0	0	0	0
	15	14	13	12	11	10	9	8	7	6	5	4	3	2	1	0
	reserved		CAPWIDTH		reserved						WRWSM		reserved			RDWSM
Type	RO	RO	RW	RW	RO	RO	RO	RO	RO	RO	RO	RW	RO	RO	RO	RW
Reset	1	0	1	0	0	0	0	0	0	0	0	0	0	0	0	0

Bit/Field	Name	Type	Reset	Description
31:26	reserved	RO	0x00	Software should not rely on the value of a reserved bit. To provide compatibility with future products, the value of a reserved bit should be preserved across a read-modify-write operation.
25:24	IRDYDLY	RW	0x0	CS3n Input Ready Delay Value Description 0 reserved 1 Stall begins one EPI clocks past iRDY low being sampled on the rising edge of EPIO clock. 2 Stall begins two EPI clocks past iRDY low being sampled on the rising edge of EPIO clock. 3 Stall begins three EPI clocks past iRDY low being sampled on the rising edge of EPIO clock.
23:14	reserved	RO	0x002	Software should not rely on the value of a reserved bit. To provide compatibility with future products, the value of a reserved bit should be preserved across a read-modify-write operation. Bits [18:16] have the same RTL implementation as the <code>HB16TIMEn</code> register, even though this is not used in HB8 mode. Thus, the reset value of 0x2 is carried over from the <code>PSRAMSZ</code> bits of <code>HB16TIMEn</code> .
13:12	CAPWIDTH	RW	0x2	CS3n Inter-transfer Capture Width Controls the delay between Host-Bus transfers. Value Description 0x0 Reserved 0x1 1 EPI clock. 0x2 2 EPI clock. 0x3 Reserved

Bit/Field	Name	Type	Reset	Description
11:5	reserved	RO	0x00	Software should not rely on the value of a reserved bit. To provide compatibility with future products, the value of a reserved bit should be preserved across a read-modify-write operation.
4	WRWSM	RW	0	<p>CS3n Write Wait State Minus One</p> <p>This bit is used with the <code>WRWS</code> field in EPIHB8CFG4. This field is not applicable in BURST mode.</p> <p>Value Description</p> <p>0 No change in the number of wait state clock cycles programmed in the in <code>WRWS</code> field in EPIHB8CFG4 register.</p> <p>1 Wait state value is now: <code>WRWS - 1</code> <code>WRWS</code> field is programmed in EPIHB8CFG4.</p>
3:1	reserved	RO	0x0	Software should not rely on the value of a reserved bit. To provide compatibility with future products, the value of a reserved bit should be preserved across a read-modify-write operation.
0	RDWSM	RW	0	<p>CS3n Read Wait State Minus One</p> <p>This field is used with <code>RDWS</code> field in EPIHB8CFG4. This bit is not applicable in BURST mode.</p> <p>Value Description</p> <p>0 No change in the number of wait state clock cycles programmed in the <code>RDWS</code> field of EPIHB8CFG4.</p> <p>1 Wait state value is now: <code>RDWS - 1</code> <code>RDWS</code> field is programmed in EPIHB8CFG4.</p>

Register 45: EPI Host-Bus 16 Timing Extension (EPIHB16TIME4), offset 0x31C**Important:** The `MODE` field in the `EPICFG` register determines which configuration is enabled.For `EPIHB16TIME4` to be valid, the `MODE` field must be 0x3.

EPI Host-Bus 16 Timing Extension (EPIHB16TIME4)

Base 0x400D.0000

Offset 0x31C

Type RW, reset 0x0002.2000

	31	30	29	28	27	26	25	24	23	22	21	20	19	18	17	16
	reserved						IRDYDLY		reserved						PSRAMSZ	
Type	RO	RO	RO	RO	RO	RO	RW	RW	RO	RO	RO	RO	RO	RW	RW	RW
Reset	0	0	0	0	0	0	0	0	0	0	0	0	0	0	1	0
	15	14	13	12	11	10	9	8	7	6	5	4	3	2	1	0
	reserved		CAPWIDTH		reserved						WRWSM		reserved		RDWSM	
Type	RO	RO	RW	RW	RO	RO	RO	RO	RO	RO	RO	RW	RO	RO	RO	RW
Reset	0	0	1	0	0	0	0	0	0	0	0	0	0	0	0	0

Bit/Field	Name	Type	Reset	Description																		
31:26	reserved	RO	0x00	Software should not rely on the value of a reserved bit. To provide compatibility with future products, the value of a reserved bit should be preserved across a read-modify-write operation.																		
25:24	IRDYDLY	RW	0x0	CS3n Input Ready Delay <table border="1"> <thead> <tr> <th>Value</th> <th>Description</th> </tr> </thead> <tbody> <tr> <td>0</td> <td>reserved</td> </tr> <tr> <td>1</td> <td>Stall begins one EPI clocks past iRDY low being sampled on the rising edge of EPIO clock.</td> </tr> <tr> <td>2</td> <td>Stall begins two EPI clocks past iRDY low being sampled on the rising edge of EPIO clock.</td> </tr> <tr> <td>3</td> <td>Stall begins three EPI clocks past iRDY low being sampled on the rising edge of EPIO clock.</td> </tr> </tbody> </table>	Value	Description	0	reserved	1	Stall begins one EPI clocks past iRDY low being sampled on the rising edge of EPIO clock.	2	Stall begins two EPI clocks past iRDY low being sampled on the rising edge of EPIO clock.	3	Stall begins three EPI clocks past iRDY low being sampled on the rising edge of EPIO clock.								
Value	Description																					
0	reserved																					
1	Stall begins one EPI clocks past iRDY low being sampled on the rising edge of EPIO clock.																					
2	Stall begins two EPI clocks past iRDY low being sampled on the rising edge of EPIO clock.																					
3	Stall begins three EPI clocks past iRDY low being sampled on the rising edge of EPIO clock.																					
23:19	reserved	RO	0x000	Software should not rely on the value of a reserved bit. To provide compatibility with future products, the value of a reserved bit should be preserved across a read-modify-write operation.																		
18:16	PSRAMSZ	RW	0x2	PSRAM Row Size Defines the row size for the PSRAM controlled by CS3n <table border="1"> <thead> <tr> <th>Value</th> <th>Description</th> </tr> </thead> <tbody> <tr> <td>0x0</td> <td>No row size limitation</td> </tr> <tr> <td>0x1</td> <td>128 B</td> </tr> <tr> <td>0x2</td> <td>256 B</td> </tr> <tr> <td>0x3</td> <td>512 B</td> </tr> <tr> <td>0x4</td> <td>1024 B</td> </tr> <tr> <td>0x5</td> <td>2048 B</td> </tr> <tr> <td>0x6</td> <td>4096 B</td> </tr> <tr> <td>0x7</td> <td>8192 B</td> </tr> </tbody> </table>	Value	Description	0x0	No row size limitation	0x1	128 B	0x2	256 B	0x3	512 B	0x4	1024 B	0x5	2048 B	0x6	4096 B	0x7	8192 B
Value	Description																					
0x0	No row size limitation																					
0x1	128 B																					
0x2	256 B																					
0x3	512 B																					
0x4	1024 B																					
0x5	2048 B																					
0x6	4096 B																					
0x7	8192 B																					

Bit/Field	Name	Type	Reset	Description
15:14	reserved	RO	0x0	Software should not rely on the value of a reserved bit. To provide compatibility with future products, the value of a reserved bit should be preserved across a read-modify-write operation.
13:12	CAPWIDTH	RW	0x2	<p>CS3n Inter-transfer Capture Width Controls the delay between Host-Bus transfers.</p> <p>Value Description</p> <p>0x0 Reserved</p> <p>0x1 1 EPI clock.</p> <p>0x2 2 EPI clock.</p> <p>0x3 Reserved</p>
11:5	reserved	RO	0x00	Software should not rely on the value of a reserved bit. To provide compatibility with future products, the value of a reserved bit should be preserved across a read-modify-write operation.
4	WRWSM	RW	0	<p>CS3n Write Wait State Minus One This bit is used with the WRWS field in EPIHB16CFG4. This field is not applicable in BURST mode.</p> <p>Value Description</p> <p>0 No change in the number of wait state clock cycles programmed in the in WRWS field in EPIHB16CFG4 register.</p> <p>1 Wait state value is now: WRWS - 1 WRWS field is programmed in EPIHB16CFG4.</p>
3:1	reserved	RO	0x0	Software should not rely on the value of a reserved bit. To provide compatibility with future products, the value of a reserved bit should be preserved across a read-modify-write operation.
0	RDWSM	RW	0	<p>CS3n Read Wait State Minus One This field is used with RDWS field in EPIHB16CFG4. This bit is not applicable in BURST mode.</p> <p>Value Description</p> <p>0 No change in the number of wait state clock cycles programmed in the RDWS field of EPIHB16CFG4.</p> <p>1 Wait state value is now: RDWS - 1 RDWS field is programmed in EPIHB16CFG4.</p>

Register 46: EPI Host-Bus PSRAM (EPIHBPSRAM), offset 0x360

This register holds the PSRAM configuration register value. When the `WRCRE` bit in the `EPIHB16CFGn` register is set, all 21 bits of the `EPIHBPSRAM` register's `CR` value are written to the PSRAM's configuration register. When the `RDCRE` bit is set in the `EPIHB16CFGn` register, a read of the PSRAM's configuration register takes place and the value is written to bits[15:0] of the `EPIHBPSRAM`. Bits[20:16] will not contain any valid data.

EPI Host-Bus PSRAM (EPIHBPSRAM)

Base 0x400D.0000

Offset 0x360

Type RW, reset 0x0000.0000

	31	30	29	28	27	26	25	24	23	22	21	20	19	18	17	16
	reserved											CR				
Type	RO	RO	RO	RO	RO	RO	RO	RO	RO	RO	RO	RW	RW	RW	RW	RW
Reset	0	0	0	0	0	0	0	0	0	0	0	0	0	0	0	0
	15	14	13	12	11	10	9	8	7	6	5	4	3	2	1	0
	CR															
Type	RW	RW	RW	RW	RW	RW	RW	RW	RW	RW	RW	RW	RW	RW	RW	RW
Reset	0	0	0	0	0	0	0	0	0	0	0	0	0	0	0	0

Bit/Field	Name	Type	Reset	Description
31:21	reserved	RO	0x000	Software should not rely on the value of a reserved bit. To provide compatibility with future products, the value of a reserved bit should be preserved across a read-modify-write operation.
20:0	CR	RW	0x000000	PSRAM Config Register During a configuration write, all 21 bits of the <code>CR</code> bit field are written to the PSRAM. During configuration reads, <code>CR</code> bits[15:0] of this register contain the configuration read of the PSRAM. <code>CR</code> [20:16] will not contain valid data.

12 Cyclical Redundancy Check (CRC)

The Cyclical Redundancy Check (CRC) computation module can be used for message transfer and safety system checks, as well as in conjunction with the AES and DES modules. The following features are supported:

- Support four major CRC forms:
 - CRC16-CCITT as used by CCITT/ITU X.25
 - CRC16-IBM as used by USB and ANSI
 - CRC32-IEEE as used by IEEE802.3 and MPEG2
 - CRC32C as used by G.Hn
- Allows word and byte feed
- Supports auto-initialization and manual initialization
- Supports MSb and LSb
- Supports CCITT post-processing
- Can be fed by μ DMA, Flash memory and code

12.1 Functional Description

The following sections describe the features of CRC.

12.1.1 CRC Support

The purpose of the CRC engine is to accelerate CRC and TCP checksum operation. The result of the CRC operation is a 32- and 16-bit signature which can be used to check the sanity of data. The required mode of operation is selected through the `TYPE` bit in the **CRC Control (CRCCTRL)** register, offset 0x400. A μ DMA software channel can be used to burst data into the CRC module. CRCs are computed combinatorially in one clock.

The CRC module contains all of the control registers to which the input context interfaces. Because CRC calculations are a single cycle, as soon as data is written to **CRC Data Input (CRCDIN)** register, the result of CRC/CSUM is updated in the **CRC SEED/Context (CRCSEED)** register, offset 0x410. The input data is computed by the selected CRC polynomial or CSUM.

12.1.1.1 CRC Checksum engine

Software can offload the CRC and checksum task to the CRC checksum engine accelerator. The accelerator has registers that need to be programmed to initiate processing. These registers should be fed with data in order to calculate CRC/CSUM. Software should configure the μ DMA channel for data movement through the **DMA Channel Map Select n (DMACHMAPn)** register in the μ DMA module. Further μ DMA configuration guidelines are available in the “Micro Direct Memory Access (μ DMA)” on page 686.

The starting seed for the CRC and checksum operation is programmed in the **CRC SEED/Context (CRCSEED)** register at offset 0x410. Depending on the encoding of the `INIT` field in the **CRCCTRL** register, the value of the `SEED` field can be initialized to any one of the following:

- A unique context value written to the **CRCSEED** register (INIT=0x0)
- All 0s (INIT=0x2)
- All 1s (INIT=0x3)

Once the operation is done, software should read the result from the **CRC Post Processing Result (CRCRSLTPP)** register, offset 0x418, and a software channel μ DMA interrupt should be used to identify completion.

12.1.1.2 Data Size

The CRC module supports data being fed 32-bit words and 8 bits at a time and can dynamically switch back and forth. The data size is configured by programming the **SIZE** bit in the **CRCCTRL** register, offset 0x400.

Because CRC is a division on a long stream of bits, the application must take into consideration the bit order. When processing message data that is read out by words, bit order is not an issue. For example, if the data value in the message is 0x12345678, the most significant eight byte is 0x12 (00010010 in binary). If the data is processed as bytes, 0x12, 0x34, 0x56, and 0x78 are copied into memory in that order and the word is stored as 0x78563412, where 0x12 is written as byte 0, 0x34 is written as byte 1, and so on.

12.1.1.3 Endian Configuration

The following endian configuration is provided by the **ENDIAN** field in the **CRCCTRL** register:

- Swap byte in half-word
- Swap half word

Input data width is four bytes, hence the configuration only affects the four-byte word. The **ENDIAN** bit field supports the following configurations, assuming the input word is {B3, B2, B1, B0}

Table 12-1. Endian Configuration

ENDIAN Encoding	Definition	Configuration
0x0	Configuration unchanged.	{B3, B2, B1, B0}
0x1	Bytes are swapped in half-words but half-words are not swapped	{B2, B3, B0, B1}
0x2	Half-words are swapped but bytes are not swapped in half-word.	{B1, B0, B3, B2}
0x3	Bytes are swapped in half-words and half-words are swapped.	{B0, B1, B2, B3}

Bit reversal is supported by the **BR** bit in the **CRCCTRL** register. The bit reversal operation works in tandem with endian control. For example, the above table with the **BR** option set would look like this:

Table 12-2. Endian Configuration with Bit Reversal

ENDIAN Encoding	Initial Endian Configuration	Configuration with Bit Reversal (BR = 1)
0x0	Configuration unchanged. {B3[31:24], B2[23:16], B1[15:8], B0[7:0]}	B3[24:31], B2[16:23], B1[8:15], B0[0:7]

Table 12-2. Endian Configuration with Bit Reversal (*continued*)

ENDIAN Encoding	Initial Endian Configuration	Configuration with Bit Reversal (BR = 1)
0x1	Bytes are swapped in half-words but half-words are not swapped {B2[23:16], B3[31:24], B0[7:0], B1[15:8]}	B2[16:23],B3[24:31],B0[0:7],B1[8:15]
0x2	Half-words are swapped but bytes are not swapped in half-word. {B1[15:8], B0[7:0], B3[31:24], B2[23:16]}	B1[8:15],B0[0:7],B3[24:31],B2[16:23]
0x3	Bytes are swapped in half-words and half-words are swapped {B0[7:0], B1[15:8], B2[23:16], B3[31:24]}	B0[0:7],B1[8:15],B2[16:23],B3[24:31]

12.2 Initialization and Configuration

The following describes the initialization and configuration procedures of the CRC module.

12.2.1 CRC Initialization and Configuration

The CRC engine works in push through mode, which means it works on streaming data. This section describes the steps for initializing the CRC module:

1. Enable the CRC by setting the `R0` bit in the CRC and Cryptographic Modules (RCGCCM) register, System Control offset 0x674.
2. Configure the desired CRC data size, bit order, endian configuration and CRC type by programming the **CRC Control (CRCCTRL)** register, offset 0x400.
3. If the CRC value has not been initialized to all 0s or all 1s using the `INIT` field in the **CRCCTRL** register, program the initial value in the **CRC SEED/Context (CRCSEED)** register, offset 0x410.
4. Repeatedly write the `DATAIN` field in the **CRC Data Input (CRCDIN)** register, offset 0x414. If the `SIZE` bit in the **CRCCTRL** register is set to select byte, the CRC engine operates in byte mode and only the least significant byte is used for CRC calculation.
5. When CRC is finished, read the **CRCSEED** register for the final result. If using post-processing, the raw CRC result is stored in the **CRCSEED** register and the final, post-processed result can be read from the **CRC Post-Processing Result (CRCRSLTPP)** register, offset 0x418. Post-processing options are selectable through the `OBR` and `OLNV` bits of the **CRCCTRL** register.

Alternatively a software μ DMA channel can be configured to copy data from the source into the **CRCDIN** register. When configuring the μ DMA, the destination should be configured to not increment. For more information on how to configure the μ DMA, refer to “Micro Direct Memory Access (μ DMA)” on page 686.

12.2.1.1 Data Endian Convention for the CRC Engine

If the input stream is expressed as a byte stream, `Din`, where `Din` = {D0, D1, D2, D3, D4, D5, D6, D7, D8, D9, D11, D12, D13, D14, D15, D16.....}, then data should be fed to the CRC engine as follows:

- If operating in Byte mode, the **CRCDIN** register should be written in the following order:
 1. {00, 00, 00, D0}

2. {00, 00, 00, D1}
3. {00, 00, 00, D2}
4. {00, 00, 00, D3}
5. {00, 00, 00, D4}
6. {00, 00, 00, D5}
7. {00, 00, 00, D6}
8.
9.

- If operating in word mode, the **CRC DIN** register should be written in the following order:

1. {D3, D2, D1, D0}
2. {D7, D6, D5, D4}
3. {D11, D10, D9, D8}
4.
5.

12.3 Register Map

Table 12-3 on page 957 lists the CRC Module registers. The offset listed is a hexadecimal increment to the register's address, relative to the base address 0x4403.0000.

Table 12-3. CCM Register Map

Offset	Name	Type	Reset	Description	See page
0x400	CRCCTRL	RW	0x0000.0000	CRC Control	958
0x410	CRCSEED	RW	0x0000.0000	CRC SEED/Context	960
0x414	CRC DIN	RW	0x0000.0000	CRC Data Input	961
0x418	CRCRSLTPP	RO	0x0000.0000	CRC Post Processing Result	962

12.4 CRC Module Register Descriptions

This section lists and describes the CRC registers, in numerical order by address offset.

Note: The CRC module can only be accessed through privileged mode. If the μ DMA is used for CRC transfers, then the μ DMA's **DMA Channel Control (DMACHCTL)** register also needs to be programmed to allow for privileged accesses.

Register 1: CRC Control (CRCCTRL), offset 0x400

The **CRC Control (CRCCTRL)** register is used to configure control of the CRC.

CRC Control (CRCCTRL)

Base 0x4403.0000
 Offset 0x400
 Type RW, reset 0x0000.0000

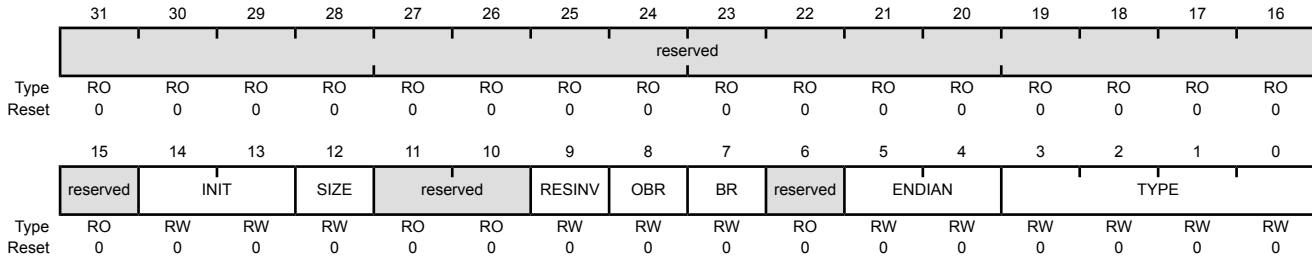

Bit/Field	Name	Type	Reset	Description										
31:15	reserved	RO	0x0000	Software should not rely on the value of a reserved bit. To provide compatibility with future products, the value of a reserved bit should be preserved across a read-modify-write operation.										
14:13	INIT	RW	0x0	<p>CRC Initialization</p> <p>Determines initialization value of CRC. This field is self-clearing. With the first write to the CRC Data Input (CRCDIN) register, this value clears to zero and remains zero for the rest of the operation unless written again.</p> <table border="1"> <tr> <th>Value</th> <th>Description</th> </tr> <tr> <td>0x0</td> <td>Use the CRCSEED register context as the starting value</td> </tr> <tr> <td>0x1</td> <td>reserved</td> </tr> <tr> <td>0x2</td> <td>Initialize to all '0s'</td> </tr> <tr> <td>0x3</td> <td>Initialize to all '1s'</td> </tr> </table>	Value	Description	0x0	Use the CRCSEED register context as the starting value	0x1	reserved	0x2	Initialize to all '0s'	0x3	Initialize to all '1s'
Value	Description													
0x0	Use the CRCSEED register context as the starting value													
0x1	reserved													
0x2	Initialize to all '0s'													
0x3	Initialize to all '1s'													
12	SIZE	RW	0	<p>Input Data Size</p> <table border="1"> <tr> <th>Value</th> <th>Description</th> </tr> <tr> <td>0</td> <td>32-bit (word)</td> </tr> <tr> <td>1</td> <td>8-bit (byte)</td> </tr> </table>	Value	Description	0	32-bit (word)	1	8-bit (byte)				
Value	Description													
0	32-bit (word)													
1	8-bit (byte)													
11:10	reserved	RO	0x0	Software should not rely on the value of a reserved bit. To provide compatibility with future products, the value of a reserved bit should be preserved across a read-modify-write operation.										
9	RESINV	RW	0	<p>Result Inverse Enable</p> <table border="1"> <tr> <th>Value</th> <th>Description</th> </tr> <tr> <td>0</td> <td>No effect</td> </tr> <tr> <td>1</td> <td>Invert the result bits before storing in the CRCRSLTPP register.</td> </tr> </table>	Value	Description	0	No effect	1	Invert the result bits before storing in the CRCRSLTPP register.				
Value	Description													
0	No effect													
1	Invert the result bits before storing in the CRCRSLTPP register.													

Bit/Field	Name	Type	Reset	Description
8	OBR	RW	0	<p>Output Reverse Enable</p> <p>Refer to Table 12-2 on page 955 for more information regarding bit reversal.</p> <p>Value Description</p> <p>0 No change to result.</p> <p>1 Bit reverse the output result byte before storing to CRCRSLTPP register. The reversal is applied to all bytes in a word.</p>
7	BR	RW	0	<p>Bit reverse enable</p> <p>Refer to Table 12-2 on page 955 for more information regarding bit reversal.</p> <p>Value Description</p> <p>0 No change to result.</p> <p>1 Bit reverse the input byte for all bytes in a word.</p>
6	reserved	RO	0	<p>Software should not rely on the value of a reserved bit. To provide compatibility with future products, the value of a reserved bit should be preserved across a read-modify-write operation.</p>
5:4	ENDIAN	RW	0	<p>Endian Control</p> <p>This field is used to program the endian configuration. The encodings below are with respect to an input word = (B3, B2, B1, B0)</p> <p>Refer to Table 12-1 on page 955 for more information regarding endian configuration and control.</p> <p>Value Description</p> <p>0x0 Configuration unchanged. (B3, B2, B1, B0)</p> <p>0x1 Bytes are swapped in half-words but half-words are not swapped (B2, B3, B0, B1)</p> <p>0x2 Half-words are swapped but bytes are not swapped in half-word. (B1, B0, B3, B2)</p> <p>0x3 Bytes are swapped in half-words and half-words are swapped. (B0, B1, B2, B3)</p>
3:0	TYPE	RW	0	<p>Operation Type</p> <p>The TYPE value in the CRCCTRL register should be exclusive.</p> <p>Value Description</p> <p>0x0 Polynomial 0x8005</p> <p>0x1 Polynomial 0x1021</p> <p>0x2 Polynomial 0x4C11DB7</p> <p>0x3 Polynomial 0x1EDC6F41</p> <p>0x4-0x7 reserved</p> <p>0x8 TCP checksum</p> <p>0x9-0xF reserved</p>

Register 2: CRC SEED/Context (CRCSEED), offset 0x410

The **CRC SEED/Context (CRCSEED)** register is initially written with one of the following three values depending on the encoding of the **INIT** field in the **CRCCTRL** register:

- The context value written to the **CRCSEED** register. This encoding is for **SEED** values from a previous CRC calculation or a specific protocol. (**INIT**=0x0)
- 0x0000.0000 (**INIT**=0x2)
- 0x1111.1111 (**INIT**=0x3)

CRC SEED/Context (CRCSEED)

Base 0x4403.0000
 Offset 0x410
 Type RW, reset 0x0000.0000

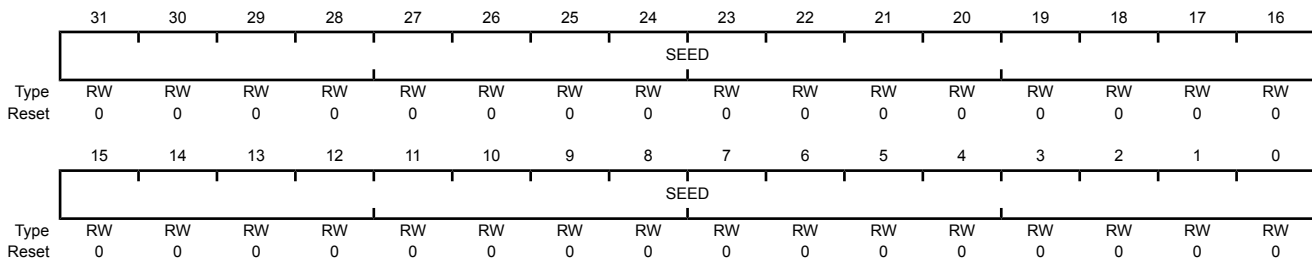

Bit/Field	Name	Type	Reset	Description
31:0	SEED	RW	0x0000.0000	SEED/Context Value This register contains the starting seed of the CRC and checksum operation. This register also holds the latest result of CRC or checksum operation.

Register 3: CRC Data Input (CRCDIN), offset 0x414

The application or μ DMA writes the **CRC Data Input (CRCDIN)** register with the next byte or word to compute.

CRC Data Input (CRCDIN)

Base 0x4403.0000

Offset 0x414

Type RW, reset 0x0000.0000

	31	30	29	28	27	26	25	24	23	22	21	20	19	18	17	16
	DATAIN															
Type	RW	RW	RW	RW	RW	RW	RW	RW	RW	RW	RW	RW	RW	RW	RW	RW
Reset	0	0	0	0	0	0	0	0	0	0	0	0	0	0	0	0
	15	14	13	12	11	10	9	8	7	6	5	4	3	2	1	0
	DATAIN															
Type	RW	RW	RW	RW	RW	RW	RW	RW	RW	RW	RW	RW	RW	RW	RW	RW
Reset	0	0	0	0	0	0	0	0	0	0	0	0	0	0	0	0

Bit/Field	Name	Type	Reset	Description
31:0	DATAIN	RW	0x0000.0000	Data Input This register contains the input data value for the CRC or checksum operation.

Register 4: CRC Post Processing Result (CRCSRSLTPP), offset 0x418

This register contains the post-processed CRC result as configured by the **CRCCTRL** register.

CRC Post Processing Result (CRCSRSLTPP)

Base 0x4403.0000
 Offset 0x418
 Type RO, reset 0x0000.0000

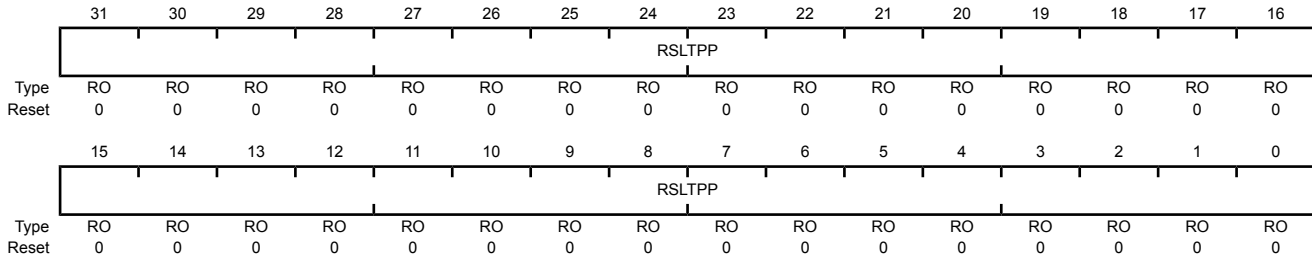

Bit/Field	Name	Type	Reset	Description
31:0	RSLTPP	RO	0x0000.0000	Post Processing Result This register contains the post-processed CRC result.

13 Advance Encryption Standard Accelerator (AES)

This section describes the Advanced Encryption Standard (AES) cryptographic hardware-accelerated module.

13.1 AES Overview

This section introduces the AES and describes the AES main functions and connections in the device.

The advanced encryption standard (AES) security modules provide hardware-accelerated data encryption and decryption operations based on a binary key. The AES is a symmetric cipher module that supports a 128-bit, 192-bit, or 256-bit key in hardware for both encryption and decryption. The AES module is based on a symmetric algorithm, meaning that the encryption and decryption keys are identical. To encrypt data means to convert it from plain text to an unintelligible form called cipher text. Decrypting cipher text converts previously encrypted data back to its original plain text form.

The main features of the AES accelerator are:

- Support for basic AES encrypt and decrypt operations:
 - Galois/Counter Mode (GCM), with basic GHASH operation
 - Counter Mode with CBC-MAC (CCM)
 - XTS Mode
- Availability of the following feedback operating modes:
 - Electronic Code Book Mode (ECB)
 - Cipher Block Chaining Mode (CBC)
 - Counter Mode (CTR)
 - Cipher Feedback Mode (CFB), 128-bit
 - F8 Mode
- Key sizes 128-, 192- and 256-bits
- Support for CBC_MAC and Fedora 9 (F9) authentication modes
- Basic GHASH operation (when selecting no encryption)
- Key scheduling in hardware
- Support for μ DMA transfers
- Fully synchronous design

13.2 AES Functional Description

The following sections describe the features of the AES Module.

13.2.1 AES Block Diagram

Figure 13-1 on page 964 shows the AES block diagram. A single-core/dual-interface architecture is used.

Figure 13-1. AES Block Diagram

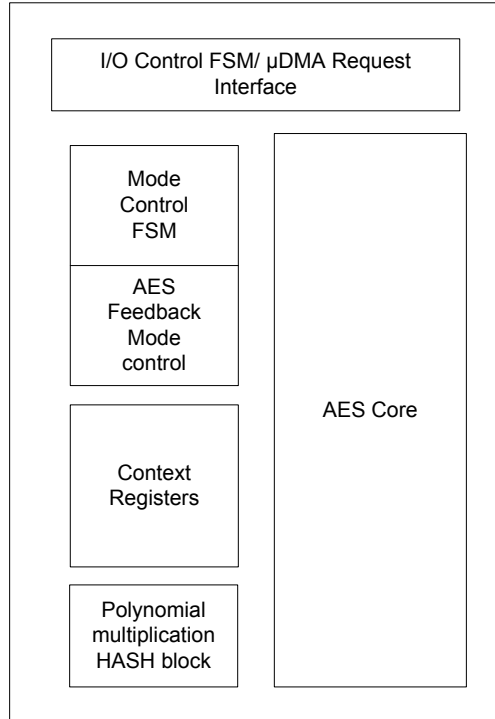

AES is an efficient implementation of the Rijndael cipher (the AES algorithm) and a 128-bit polynomial multiplication (referred to here as GHASH, as per the AES-GCM specification). Rijndael is a block cipher in which each data block is 128 bits. The polynomial multiplication multiplies two 128-bit vectors using the smallest 128-bit irreducible polynomial, represented by the following 128-bit string: $\{0^{120}\}||10000111$. The two implementations are combined into the AES wide-bus engine.

Depending on the availability of context and data, the AES wide-bus engine is automatically triggered to process the data. The AES wide-bus engine is directly connected to the context and data registers so that it can immediately start processing when all data is available. The AES wide-bus engine also interfaces to the I/O Control FSM/ μ DMA Request Interface.

AES comprises the following major functional blocks:

- Global control FSM and μ DMA interface
- Register interface module
- The AES wide-bus engine

The AES wide-bus engine, which is the major top-level component, comprises the following functional blocks:

- Mode control FSM: Manages the data flow to and from the AES wide-bus engine and starts each encryption/decryption operation.

- Feedback modes: The logic that implements the various feedback modes supported by AES.
- GHASH core: The polynomial multiplication algorithm used for AES-GCM
- AES key scheduler: Generates AES encryption and decryption (round) keys
- AES encryption core: The AES encryption algorithm
- AES decryption core: The AES decryption algorithm
- Substitution-boxes (S-Boxes): Contain AES S-Box GF(2⁸) implementations

AES encryption requires a specific number of rounds, depending on the key length. The supported key lengths are 128-, 192-, and 256-bit, which require 10, 12, and 14 rounds, respectively, or 32, 38, and 44 clock cycles, respectively, because {number of clock cycles} = 2 + 3 x {number of rounds}.

The larger key lengths provide greater encryption strength at the expense of additional rounds and therefore reduced throughput. The overall throughput of the AES executing polynomial multiplication is adjusted based on the overall cryptographic performance. The AES module contains one Electronic Codebook (ECB) core and a dedicated 32-cycle polynomial multiplication module for performing GHASH operations. Polynomial multiplication operates in parallel with the AES core, if data is available for both modules.

Depending on the key size (128/192/256 bits), this core requires 32, 38, or 44 clock cycles to process one 128-bit data block. While one data block processes, the next block can be preloaded immediately. When a block is preloaded, the previous block must finish before additional data can be loaded. Therefore, once the pipeline is full, sequential data blocks can be passed every 32, 38, or 44 clock cycles.

13.2.1.1 Interfaces

The interface signals to the AES module can be grouped into the following four categories:

- Clock and reset signals
- Register interface
- μ DMA/INT interface, used to request new context and packet data or to indicate available result data (encrypted/decrypted data or authentication result)

13.2.1.2 Register Interface

The register interface block performs all address decoding and control. However, not all registers are located in this block. The context and data input registers are in the AES wide-bus engine. The data output registers are available in this block.

13.2.1.3 AES Wide-Bus Engine

The AES wide-bus engine performs the cryptographic operations. The composition of the AES core is:

- The main data path operates on the input block, performing the required substitution, shift, and mix operations.
- The key scheduler generates the round keys. A new subkey is generated and XORed with the data each round.

AES Key Scheduler

The AES key scheduler generates the round keys. During each round, a new subkey is generated from the input key to be XORed with the data. Round keys are generated on-the-fly and parallel to data processing to minimize register requirements.

For encryption operations, the key sequencer transfers the initial key data to the AES core. For decryption operations, the key scheduler must provide the final subkey to the AES core so it can generate the subkeys in reverse order.

AES Encryption Core

The AES encryption core implements the Rijndael algorithm as specified in [FIPS-197]. This core operates on the input block and performs the required substitution, shift, and mix operations. For each round, the encryption core receives the proper round key from the AES key scheduler. A fundamental component of the AES algorithm is the S-Box. The S-Box provides a unique 8-bit output for each 8-bit input. This implementation of the AES encryption core has a 64-bit data path.

AES Decryption Core

The architecture of the AES decryption core is generally the same as the architecture of the encryption core. One difference is that the generation of round keys for decryption requires an initial conversion of the input key (always supplied by the host in the form of an encryption key) to the corresponding decryption key. This conversion is done by performing a dummy encryption operation and storing the final round key as a decryption key. The key scheduler is then reversed to generate the round keys for the decryption operation. Consequently, for each sequence of decryption operations under the same key, a single throughput reduction equal to the time to encrypt a single block occurs. Once a decryption key is generated, subsequent decryption operations with the same key use this generated decryption key directly.

AES Feedback Mode Block

The AES feedback mode block buffers the feedback parameters and controls the various feedback modes. For more information about the ECB, CBC, CTR, and CFB modes of operation, see the [NIST-SP800-38A](#) specification.

CTR implements the standard incrementing function, as described in the NIST-SP800-38A specification, with m set to 16 or a multiple of 32.

AES-XTS mode requires a polynomial multiplication for initialization vector (IV) generation of the AES operation. This multiplication can be simplified when the first result is available due to the definition and use of the block number within a unit. The input for the polynomial multiplication is not directly j , but α^j , where $\alpha = x^2$ in the $GF(2^{128})$ domain.

In addition, f8 encryption/decryption mode and f9 and (X)CBC-MAC authentication modes are available.

GHASH Block

The data sequencer manages the data flow to and from the AES core. For data input, the data sequencer monitors the input buffer until a 16-byte block is available. If the AES core is idle, the data sequencer writes this data block to the internal working registers of the AES core, thus clearing the buffer for the next block.

After completing an encryption or decryption operation, the data sequencer writes the AES output to the output buffer. If the output buffer is full at the time of completion, the AES core is held until the buffer clears. Although the data sequencer is designed to support uninterrupted packet encryption, the host must properly manage the input and output packet buffers to achieve optimal performance.

13.2.2 AES Algorithm

The AES algorithm generates block ciphers. The AES block size is 16 bytes. The AES key(s) can be coded on 128, 192, or 256 bits. The larger key sizes provide a higher level of security, but at the cost of a moderate decrease in throughput.

For the AES algorithm:

- The length of the input and output blocks is 128 bits, which is represented by $N_b = 4$, which reflects the number of 32-bit words.
- The length of the cipher key (K) is 128, 192, or 256 bits. The key length is represented by $N_k = 4, 6, \text{ or } 8$, which reflects the number of 32-bit words in the cipher key.
- The number of rounds to be performed during the execution of the algorithm is dependent on the key size. The number of rounds is represented by N_r , where $N_r = 10$ when $N_k = 4$ (128-bit key); $N_r = 12$ when $N_k = 6$ (192-bit key); and $N_r = 14$ when $N_k = 8$ (256-bit key).

Table 13-1 on page 967 lists the combinations of keys, blocks, and rounds.

Table 13-1. Key-Block-Round Combinations

Key	Key Length (Nk)	Block Size (Nb)	Number of Rounds (Nr)
128 bits	4	4	10
192 bits	6	4	12
256 bits	8	4	14

The AES algorithm for cipher and inverse cipher uses a round function composed of four different byte-oriented transformations:

- Byte substitution using a substitution table (S-Box)

This transformation is a non-linear byte substitution that operates independently on each byte of the state (the state is an intermediate processed block of 128 bits inside the AES; the state is arranged as an array of $[4 \times N_k]$ bytes) using an S-Box. This S-Box transformation is reversible.
- Shifting rows of the state array by different offsets

In this transformation, the bytes in the last three rows of the state are cyclically shifted over different numbers of bytes (offsets). The first row ($r = 0$) is not shifted.
- Mixing the data within each column of the state array

This transformation operates on the state column-by-column, treating each column as a four-term polynomial. The columns are considered polynomials over $GF(2^8)$ and multiplied modulo $x^4 + 1$ with a fixed polynomial $a(x)$.
- Adding a round key to the state

In this transformation, a round key is added to the state by a simple bitwise XOR operation. Each round key consists of N_b words from the key schedule.

The AES algorithm takes the cipher key (K) and performs a key expansion routine to generate a key schedule. The key expansion generates a total of $N_b \times (N_r + 1)$ words: The algorithm requires an initial set of N_b words, and each of the N_r rounds requires N_b words of key data. The resulting key schedule consists of a linear array of 4-byte words, denoted $[w_i]$, with i in the range $0 \leq i < N_b \times (N_r + 1)$.

13.2.3 AES Operating Modes

13.2.3.1 Supported Modes of Operation

ECB Feedback Mode

Figure 13-2 on page 968 shows the basic ECB feedback mode of operation, where the input data is passed directly to the basic cryptographic core and the output is passed directly to the output buffer.

For decryption, the cryptographic core operates in reverse: the decryption data path is used for data processing, whereas encryption uses the encryption data path.

Figure 13-2. AES - ECB Feedback Mode

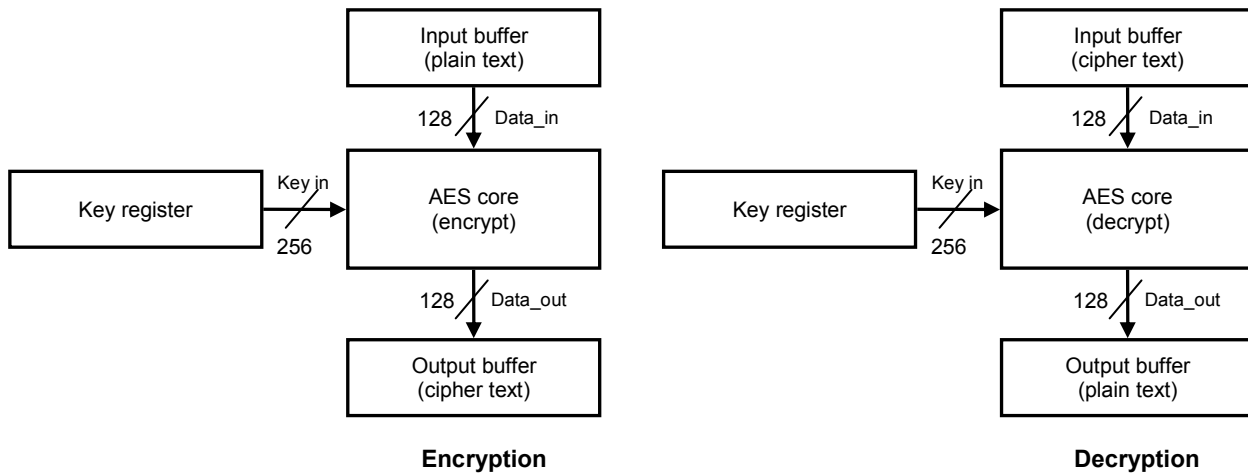

CBC Feedback Mode

Figure 13-3 on page 969 shows the CBC feedback mode of operation, where the input data is XORed with the IV before it is passed to the basic cryptographic core. The output of the cryptographic core passes directly to the output buffer and becomes the next IV.

The operation is reversed for decryption, resulting in an XOR at the output of the cryptographic core. The input cipher text of the current operation is the IV for the next operation.

Figure 13-3. AES - CBC Feedback Mode

**CTR and ICM Feedback Modes**

Figure 13-4 on page 969 shows the counter feedback (CTR/ICM) mode of operation. This operation encrypts the IV. The output of the cryptographic core (encrypted IV) is XORed with the data, thus creating the output result.

The IV is built out of two components: a fixed part and a counter part. The counter part is incremented with each block. The counter width is selectable per context and can be 16, 32, 64, 96, or 128 bits wide. In this mode, encryption and decryption use the same operation.

Figure 13-4. AES Encryption With CTR/ICM Mode

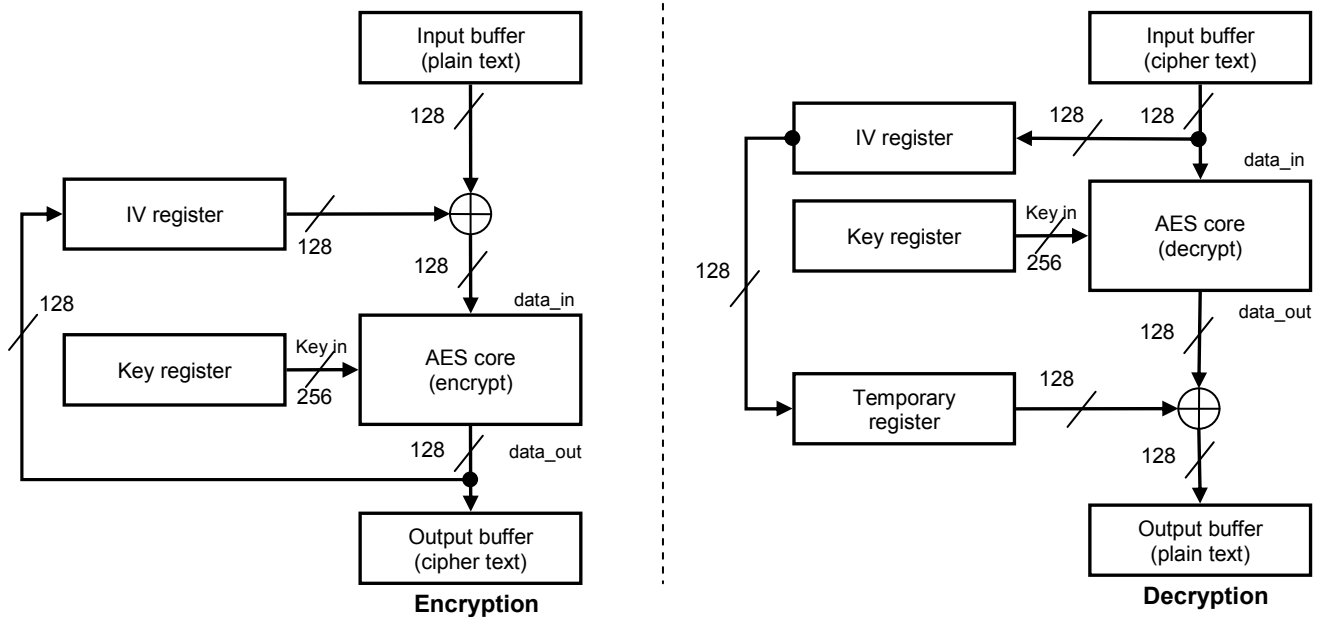
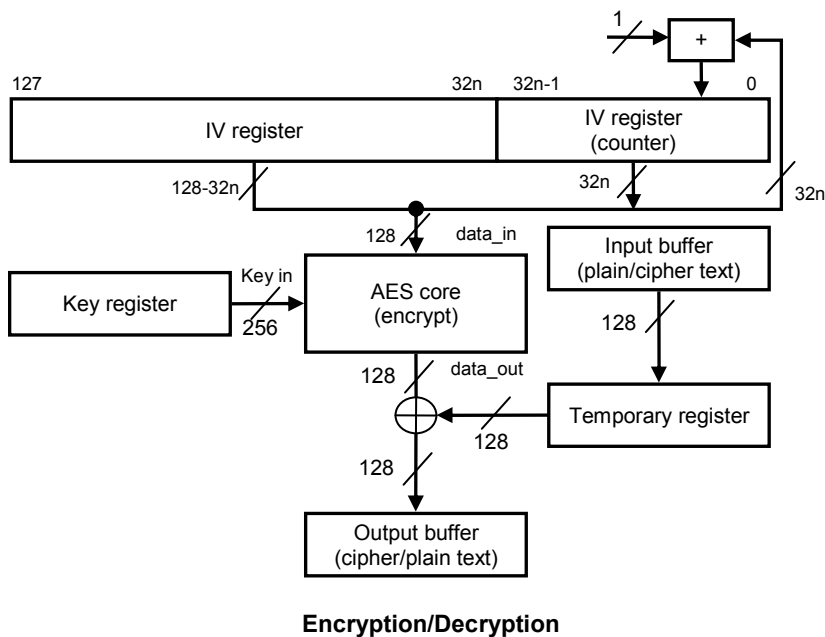

Note: The value for n can be 1, 2, 3, or 4 for CTR mode and is ½ for ICM mode.

CFB Mode

Figure 13-5 on page 970 shows the full block (128 bits) CFB mode of operation for encryption and decryption. The input for the cryptographic core is the IV; the result is XORed with the data. The result is fed back through the IV register as the next input for the cryptographic core. The decryption operation is reversed, but the cryptographic core still performs encryption.

Figure 13-5. AES - CFB Feedback Mode

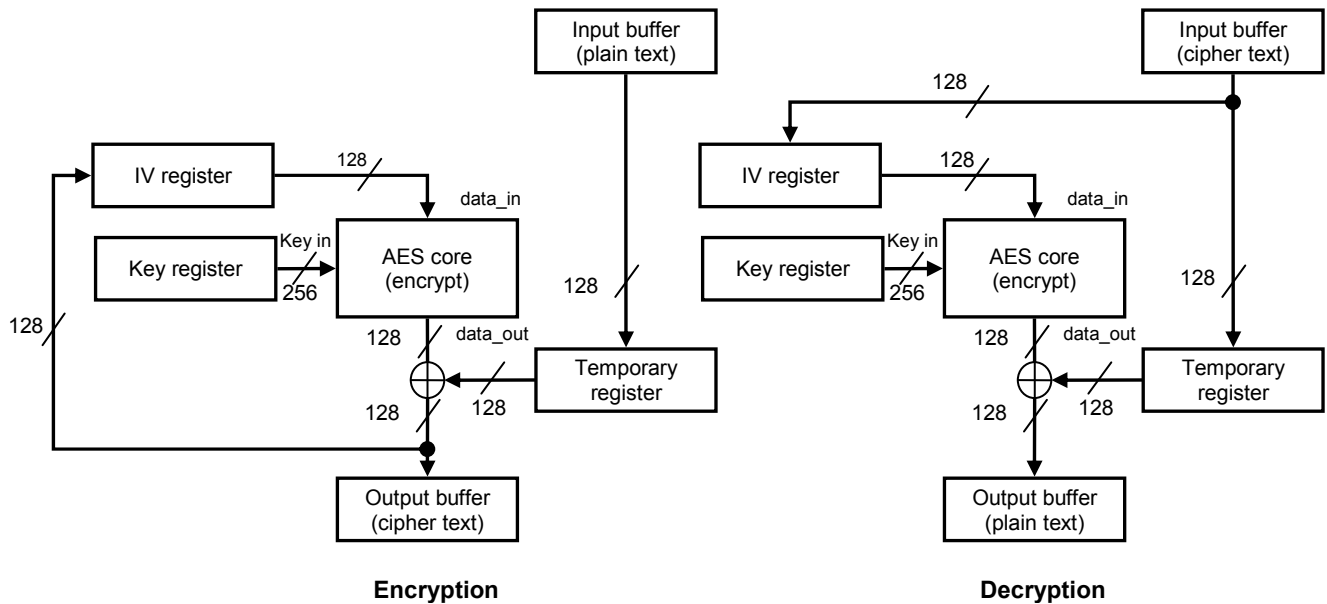

F8 Mode

Figure 13-6 on page 971 shows the F8 feedback mode of operation for encryption and decryption. The input to the cryptographic core is the result of the XOR operation of the previous cryptographic core output, a constant IV, and a block counter. The output of the cryptographic core is XORed with the input to create the result. In this mode, encryption and decryption use the same operations.

Figure 13-6. AES - F8 Mode

**XTS Operation**

Figure 13-7 on page 971 shows the XTS mode of operation for encryption and decryption. The input to the cryptographic core is XORed with the IV; the output of the cryptographic core is XORed with the same IV. For decryption, the cryptographic core operates in reverse, but the XOR operations are the same.

Figure 13-7. AES - XTS Operation

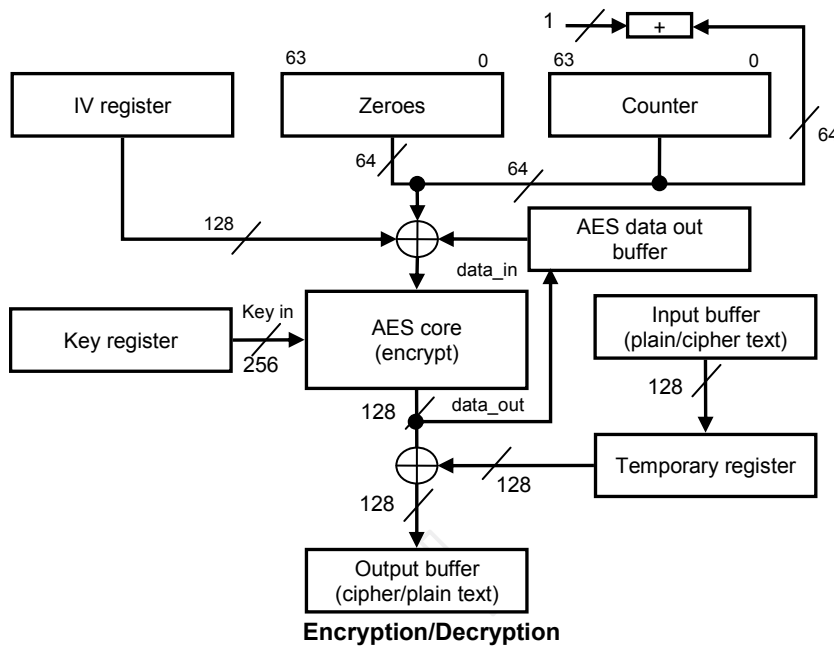
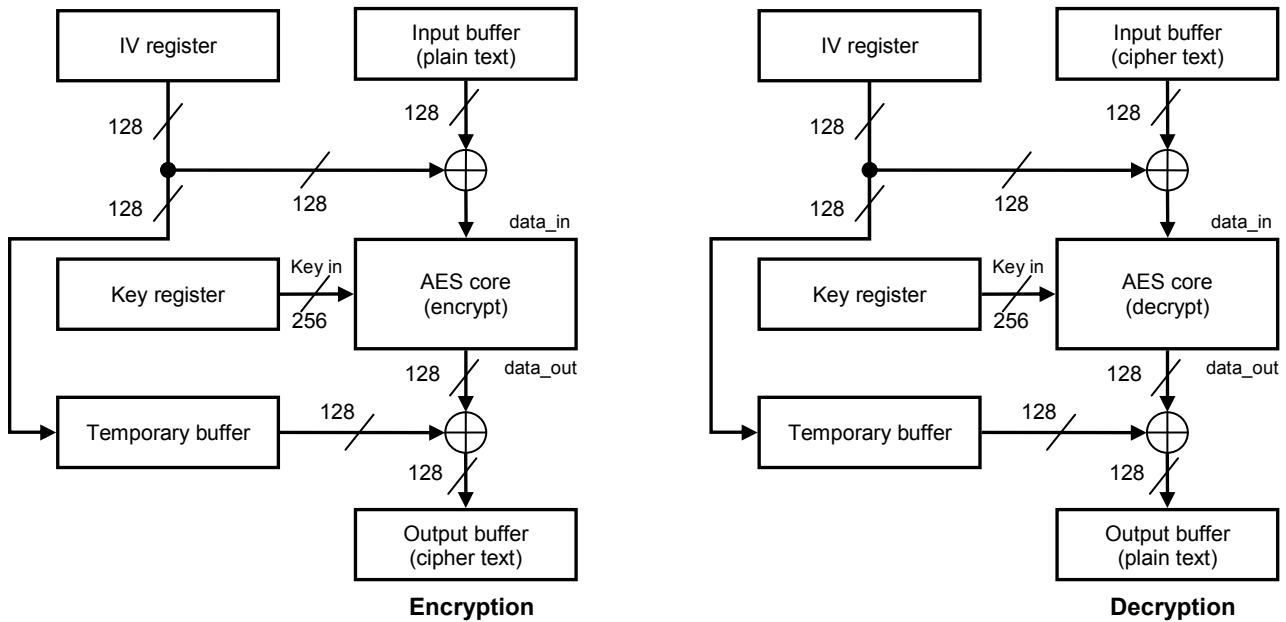

Note: The IV is created with an initial encryption, followed by an LFSR operation for each new block.

F9 Operation

Figure 13-8 on page 972 shows the F9 authentication mode of operation, where the input to the cryptographic core is XORed with the IV, and the output is XORed with the previous result to create the next result. The cryptographic core output is fed back as IV for the next block. The result is the output of the last XOR operation of the cryptographic core output.

Figure 13-8. AES - F9 Operation

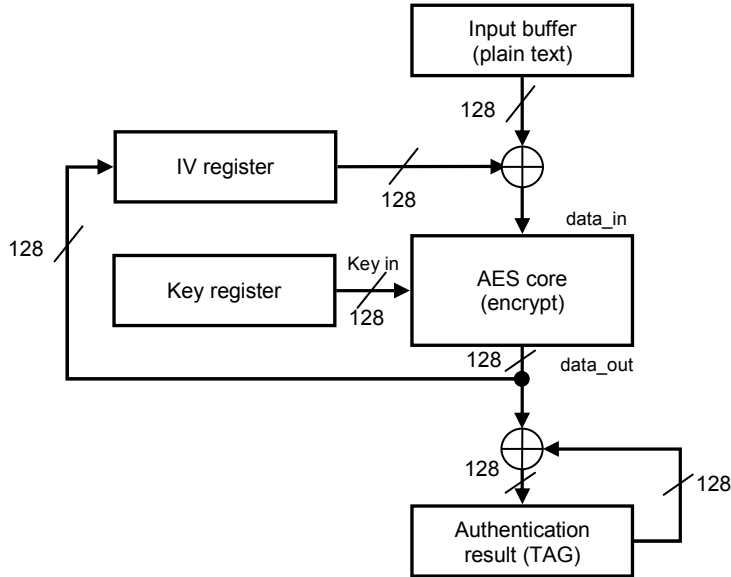

CBC-MAC Operation

Figure 13-9 on page 973 shows the CBC-MAC authentication mode of operation, where the input to the cryptographic core is XORed with the IV. The cryptographic core output is then fed back as IV for the next block. The last data input block is XORed with an additional input value stored in the temporary buffer; this can be any precalculated value and is dependent on the alignment of the last input block. The result is the cryptographic core output of the last encryption operation.

Figure 13-9. AES - CBC-MAC Authentication Mode**GCM Operation**

Figure 13-10 on page 974 shows one round of a GCM operation for encryption and decryption. A 32-bit counter is used as IV (as it is for CTR mode). The data is encrypted in the same way as in CTR mode, by XORing the cryptographic core output with the input. After the encryption/decryption, the ciphertext is XORed with the intermediate authentication result. The XORed result is used as input for the polynomial multiplication to create the next (intermediate) authentication result. For more information about the GCM protocol, see the section called “GCM Protocol Operation” on page 975.

Figure 13-10. AES - GCM Operation

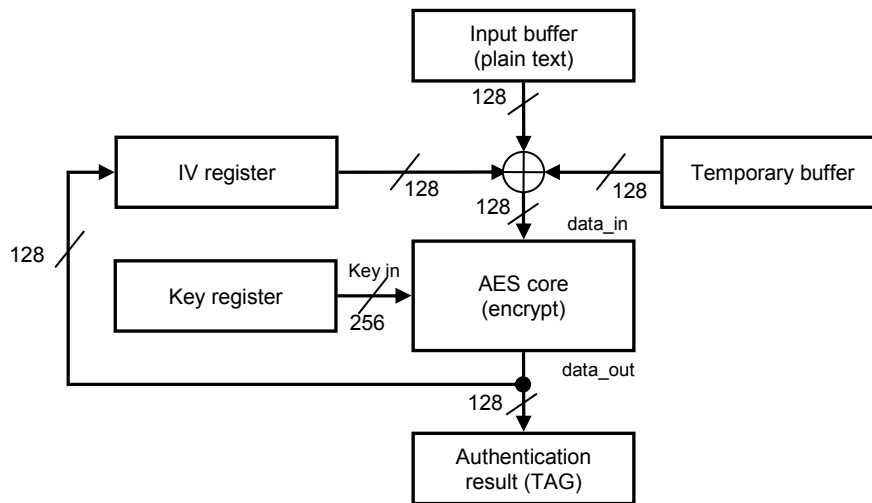
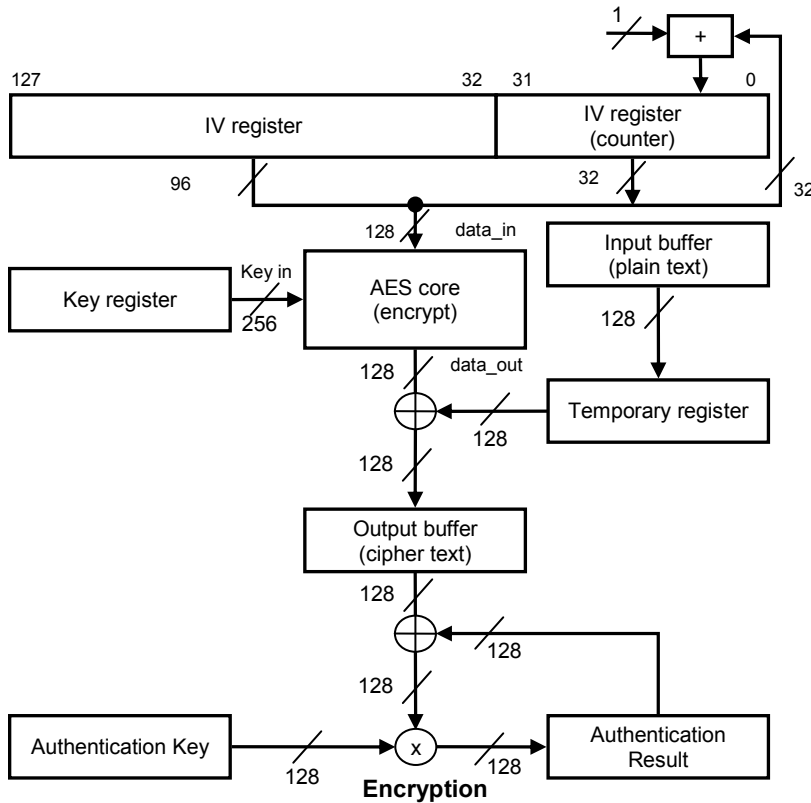

CCM Operation

Figure 13-11 on page 975 shows one round of a CCM (counter with CBC-MAC) operation for encryption and decryption. A 32-bit counter is used as IV (as it is for CTR mode). The data is encrypted in the same way as in CTR mode, by XORing the cryptographic core output with the input. Immediately after the encryption operation, the plaintext is XORed with the intermediate authentication result. The XOR result is used as input for a second encryption operation to calculate the next (intermediate) authentication result.

Figure 13-11. AES - CCM Operation

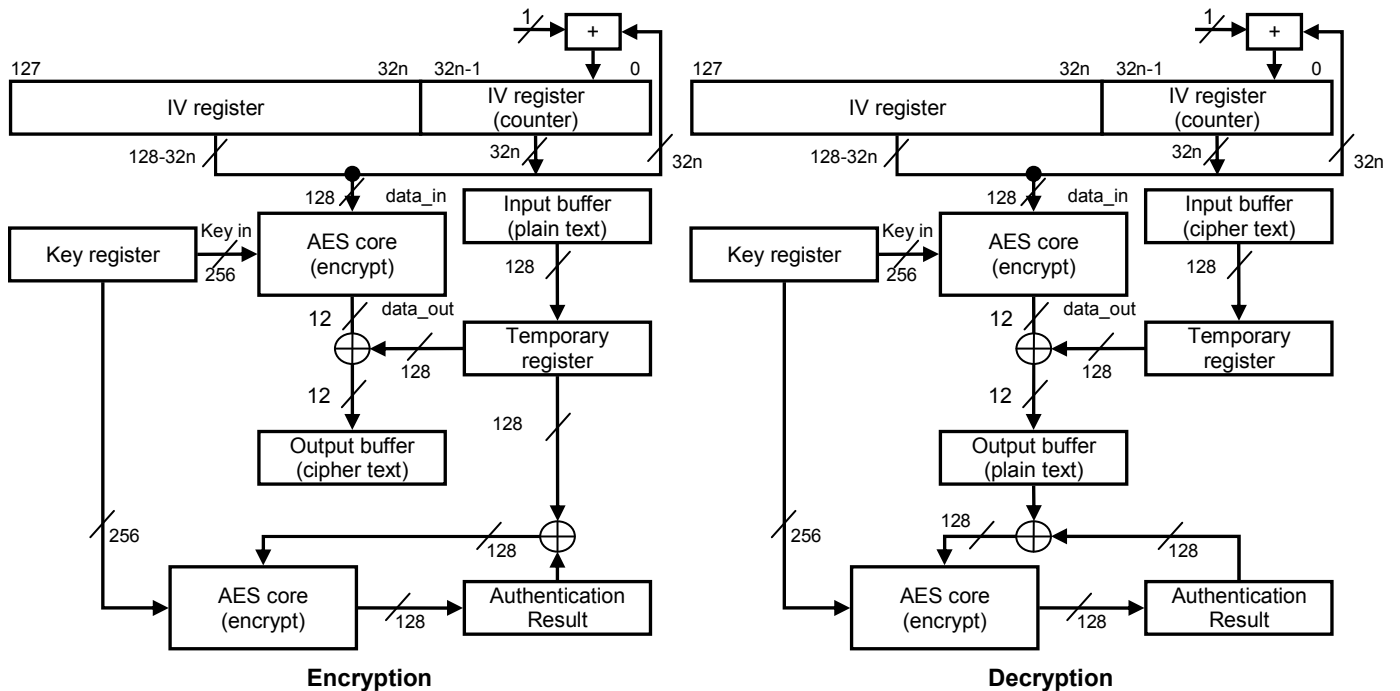

13.2.3.2 Extended and Combined Modes of Operations

This section describes the protocols (or autonomous precalculations) supported by the AES wide-bus engine.

GCM Protocol Operation

A GCM protocol operation is a combined operation consisting of encryption/decryption and authentication. A part of the input data stream can be authenticated only, while normally most of the input data is encrypted/decrypted and authenticated. The authentication-only data must always be in front of the data requiring encryption. Within GCM, the authentication-only data is called the additional authentication data (AAD). The AAD is fetched independently of other data.

The intermediate (temporary) result data is used as input to the remaining authentication operation. Because the authentication operation does not require the cryptographic core but only the polynomial multiplication, encryption/decryption and authentication can be performed in parallel. After encryption of the last data block, additional polynomial multiplication and encryption are required to authenticate a 128-bit length vector and finally encrypt the authentication result.

CCM Protocol Operation

The CCM protocol operation is a combined operation consisting of encryption/decryption and authentication. The authentication and encryption/decryption operations use the cryptographic core; these are executed sequentially on the AES core. A part of the data stream can require authentication only. The authentication-only data must always be in front of the data requiring encryption.

Authentication starts with the encryption of a predefined block B0. This block consists of flags, nonce, and message length. The next blocks contain the authentication data length concatenated with the authentication-only data. After processing the authentication-only data, the encryption/decryption operations are performed, each followed by the related authentication of the plaintext data block (which equals the input in the case of encryption, and the output in the case of

decryption). The final authentication result must be encrypted using the output of the encryption of the IV block A0. This block contains the IV (consisting of flags and nonce) concatenated with the counter, which is zero for A0.

13.2.4 AES Software Reset

To perform a software reset of the AES module, write a 1 to the `SOFTRESET` bit in the **AES System Configuration (AES_SYSCONFIG)** register. The `RESETDONE` bit in the **AES Secure System Status (AES_SYSSTATUS)** register indicates that the software reset is complete when its value is 1. When the software reset completes, the `SOFTRESET` bit in the **AES_SYSCONFIG** register is automatically reset. Software must ensure that the software reset completes before doing any operations.

The behavior of the software reset is the same as the hardware reset, except that the software reset bit resets this module without affecting the reset core domain of the entire device.

13.2.5 Power Management

To save power, the application can disable the clock to the AES module when not in use. The AES is clock gated by setting the `AESCFG` bit in the **Cryptographic Modules Clock Gating Request (CCMCGREQ)** register, CRC and Cryptographic Modules (CCM) offset 0x204. The AES in addition to the DES, SHA/MD5 and CRC can also be clock gated as a group by setting the `D0` bit in the **CRC and Cryptographic Modules (DCGCCM)** register, System Control Module offset 0x874.

13.2.6 Hardware Requests

The AES module can assert a μ DMA request for context in, context out, input data, or output data read. The **AES uDMA Interrupt Mask (AES_DMAIM)** register can be set to generate interrupts during the following events:

- Context In μ DMA request (AES0 Cin)
- Context Out μ DMA request (AES0 Cout)
- Data In μ DMA request (AES0 Din)
- Data Out μ DMA request (AES0 Dout)

The AES Module can be programmed to assert an interrupt when the uDMA has completed its last transfer. Please refer to “AES μ DMA Interrupt Register Descriptions (CCM Offset)” on page 1008 for more information.

If context and data transfers are to be handled through software, then the **AES Interrupt Enable (AES_IRQENABLE)**, offset 0x090, can be used to enable interrupt triggering when context out, context in, data in or data out is ready. The **AES Interrupt Status (AES_IRQSTATUS)**, offset 0x08C, indicates when an interrupt is triggered.

Table 13-2. Interrupts and Events

Event	Description
<code>AES_IRQSTATUS[3]: CONTEXT_OUT</code>	Context output interrupt
<code>AES_IRQSTATUS[2]: DATA_OUT</code>	Data output interrupt
<code>AES_IRQSTATUS[1]: DATA_IN</code>	Data input interrupt
<code>AES_IRQSTATUS[0]: CONTEXT_IN</code>	Context input interrupt

13.3 AES Performance Information

Table 13-3 on page 977 lists the performance for all supported key sizes and modes of operations. It assumes that the engine is kept fully utilized (that is, the host is supplying input blocks and retrieving output blocks in such a way that the engine never has to wait for input), and that the previous output has been retrieved before the next output is ready.

Table 13-3. AES Module Performance (Input/Output Block Size = 128)

Key Size	Mode of Operation	Cycles per Block ^a	Throughput (bits/cycle)
128	ECB-encrypt / decrypt	32	4.00
	CBC-decrypt		
	CTR/ICM-encrypt / decrypt		
	CFB128-decrypt		
	CBC-encrypt	33	3.88
	OFB-encrypt / decrypt		
	f8-encrypt / decrypt		
	CFB128-encrypt		
	XTS-encrypt / decrypt		
	GCM-outbound / inbound	66	1.94
	CCM-encrypt / decrypt		
	CBC-MAC ^b	33	3.88
	f9 ^b		
	192	ECB-encrypt / decrypt	38
CBC-decrypt			
CTR/ICM-encrypt / decrypt			
CFB128-decrypt			
CBC-encrypt		39	3.28
OFB-encrypt / decrypt			
f8-encrypt / decrypt			
CFB128-encrypt			
XTS-encrypt / decrypt			
GCM-outbound / inbound		78	1.64
CCM-encrypt / decrypt			
CBC-MAC ^b		39	3.28
f9 ^b			

Table 13-3. AES Module Performance (Input/Output Block Size = 128) (continued)

Key Size	Mode of Operation	Cycles per Block ^a	Throughput (bits/cycle)
256	ECB-encrypt / decrypt	44	2.91
	CBC-decrypt		
	CTR/ICM-encrypt / decrypt		
	CFB128-decrypt		
	CBC-encrypt	45	2.84
	OFB-encrypt / decrypt		
	f8-encrypt / decrypt		
	CFB128-encrypt		
	XTS-encrypt / decrypt		
	GCM-outbound inbound	90	1.42
	CCM-encrypt / decrypt		
	CBC-MAC ^b	45	2.84
	f9 ^b		

a. Standard Block Size (128 bits)

b. Input Only

The "Cycles per block" numbers do not apply to the first block after selection of a new key and/or mode of operation, or the last block before switching to a new algorithm. The next table indicates the additional clock cycles; required for changing context data.

Table 13-4. AES Module Packet Mode Switch Overhead

New Context	Cycles needed for first block/and to finish the last block	Total
mode is encrypt	1 / 1	2
mode is decrypt, key size is 128	32 / 1	33
mode is decrypt, key size is 192	38 / 1	39
mode is decrypt, key size is 256	44 / 1	45
mode is XTS, key size is 128	34 / 1	35
mode is XTS, key size is 192	40 / 1	41
mode is XTS, key size is 256	46 / 1	47
outbound GCM, AES key size is 128	33 ^a / 52	85
outbound GCM, AES key size is 192	39 ^a / 52	91
outbound GCM, AES key size is 256	45 ^a / 52	97
inbound GCM, AES key size is 128	33 ^a / 27	60
inbound GCM, AES key size is 192	39 ^a / 27	66
inbound GCM, AES key size is 256	45 ^a / 27	72
outbound CCM, AES key size is 128	33 ^b / 33	66
outbound CCM, AES key size is 192	39 ^b / 39	78
outbound CCM, AES key size is 256	45 ^b / 45	90
inbound CCM, AES key size is 128	33 ^b / 33	66
inbound CCM, AES key size is 192	39 ^b / 39	78

Table 13-4. AES Module Packet Mode Switch Overhead (continued)

New Context	Cycles needed for first block/and to finish the last block	Total
inbound CCM, AES key size is 256	45 ^b / 45	90

- a. Numbers for regular GCM mode (H is precalculated and Y0-encrypted need to be calculated internally using the new IV). If H needs to be calculated by the core (complete GCM mode), this number needs to be doubled. If Y0-encrypted is not calculated (forced to zero, such that the hash result is not encrypted) this number is zero.
- b. Numbers for regular CCM mode. Dependent on the AAD length it is possible that one additional encryption needs to be done to finalize the AAD authentication; if the additional operation is required, this number needs to be doubled.

13.4 AES Module Programming Guide

13.4.1 AES Low - Level Programming Models

This section describes the low-level hardware programming sequences for configuring and using the AES Module.

13.4.1.1 Global Initialization

The following list describes the requirements for initializing the AES and surrounding modules when AES is used for the first time after a device reset.

1. When reset has completed, enable the AES by setting the `R0` bit in the **CRC and Cryptographic Modules Run Mode Clock Gating Control (RCGCCM)**, System Control offset 0x674. When the `R0` bit is set in the **CRC and Cryptographic Modules Peripheral Ready (PRCCM)**, System Control offset 0xA74 register, the AES is powered and ready to be configured.
2. Configure the AES μ DMA channels for Context In, Context Out, Data In, and/or Data Out by programming the appropriate encoding value in the **DMA Channel Map Select n (DMACHMAPn)** register in the μ DMA module, offset 0x510. For more information on how to program channel assignments as well as enabling burst and the configured channels, refer to “Micro Direct Memory Access (μ DMA)” on page 686.
3. Execute a software reset by setting the `SOFTRESET` bit in the **AES_SYSCONFIG** register. When reset is complete, the `RESETDONE` bit reads as 1 in the **AES_SYSSTATUS** register.
4. If the AES channels are configured in the μ DMA, enable the required AES DMA requests by programming bits [9:5] of the **AES_SYSCONFIG** register, in addition to the completion interrupts in the **AES DMA Interrupt Mask (AES_DMAIM)** register, CCM offset 0x020.
5. Specify the size of the keys by programming the `KEY_SIZE` bit field in the **AES_CTRL** register.
6. Load **AES Key 1 (AES_KEY1_n)** register.
7. Load **AES Key 2 (AES_KEY2_n)** register if it is used by the configuration mode. Refer to Table 13-6 on page 987 for information regarding which configuration modes require a load to this register.
8. Configure the AES for the appropriate encryption/decryption mode (see the section called “Subsequence: Initialize CCM AES Core Mode” on page 980 through the section called “Subsequence: Initialize CBC AES Core Mode” on page 981).
9. Select encryption or decryption by programming the `DIRECTION` bit in the **AES Control (AES_CTRL)** register, offset 0x050.

13.4.1.2 Initialization Subsequence

The following sections list the initialization subsequences for the available encryption/decryption modes:

Subsequence: Initialize CCM AES Core Mode

The CCM mode initialization is as follows:

1. Define the width of the length field and the length of the authentication field by programming the `CCM_L` and `CCM_M` bit fields in the **AES_CTRL** register at offset 0x050.
2. Enable counter mode by setting the `CTR` bit in the **AES_CTRL** register.
3. Load the authentication data length in the `AUTH` field of the **AES Authentication Data Length (AES_AUTH_LENGTH)** register at offset 0x05C.
4. Select the IV counter by programming the `CTR_WIDTH` field in the **AES_CTRL** register.
5. Load the **AES Initialization Vector Input n (AES_IV_IN_n)** registers at offset 0x040 to 0x04C.

Subsequence: Initialize GCM AES Core Mode

The following steps to enable GCM mode is as follows:

1. Enable counter mode by setting the `CTR` bit in the **AES_CTRL** register.
2. Load the authentication data length in the `AUTH` field of the **AES Authentication Data Length (AES_AUTH_LENGTH)** register at offset 0x05C.
3. Select the IV counter by programming the `CTR_WIDTH` field in the **AES_CTRL** register.
4. Load the **AES Initialization Vector Input n (AES_IV_IN_n)** registers at offset 0x040 to 0x04C.

Subsequence: Initialize CBC-MAC AES Core Mode

To initialize CBC-MAC Mode:

1. Enable CBC-MAC Mode by setting the `CBCMAC` bit in the **AES_CTRL** register.
2. Select encryption mode by setting the `DIRECTION` bit in the **AES_CTRL** register at offset 0x050.
3. Load the **AES Initialization Vector Input n (AES_IV_IN_n)** registers at offset 0x040 to 0x04C.

Subsequence: Initialize F9 AES Core Mode

The steps for configuring the AES for F9 mode is as follows:

1. Enable F9 Mode by setting the `F9` bit in the **AES_CTRL** register.
2. Set the key size to 128 bits by programming the `KEY_SIZE` field to 0x1 in the **AES_CTRL** register.
3. Load the **AES Initialization Vector Input n (AES_IV_IN_n)** registers at offset 0x040 to 0x04C.

Subsequence: Initialize F8 AES Core Mode

The steps for configuring the AES for F8 mode is as follows:

1. Enable F8 Mode by setting the F8 bit in the **AES_CTRL** register.
2. Select the counter width by programming the **CTR_WIDTH** field in the **AES_CTRL** register.
3. Set the key size to 128 bits by setting the **KEY_SIZE** field to 0x1 in the **AES_CTRL** register.
4. Load the **AES Initialization Vector Input n (AES_IV_IN_n)** registers at offset 0x040 to 0x04C.

Subsequence: Initialize XTS AES Core Mode

The steps for XTS mode configuration are as follows:

1. Enable XTS Mode by configuring the **XTS** field in the **AES_CTRL** register.
2. If the **XTS** field in the **AES_CTRL** register indicates that the AAD length is required, load the AAD length in the **AES_AUTH_LENGTH** register.
3. Load the **AES Initialization Vector Input n (AES_IV_IN_n)** registers at offset 0x040 to 0x04C.

Subsequence: Initialize CFB AES Core Mode

To initialize the AES code for CFB mode:

1. Enable CFB Mode by setting the **CFB** bit in the **AES_CTRL** register.
2. Load the **AES Initialization Vector Input n (AES_IV_IN_n)** registers at offset 0x040 to 0x04C.

Subsequence: Initialize ICM AES Core Mode

To initialize the AES code for ICM mode:

1. Enable ICM Mode by setting the **ICM** bit in the **AES_CTRL** register.
2. Configure for a 16-bit counter by programming the **CTR_WIDTH** to 0x0 in the **AES_CTRL** register.
3. Load the **AES Initialization Vector Input n (AES_IV_IN_n)** registers at offset 0x040 to 0x04C.

Subsequence: Initialize CTR AES Core Mode

To initialize CTR mode:

1. Enable CTR Mode by setting the **CTR** bit in the **AES_CTRL** register.
2. Select counter width by programming the **CTR_WIDTH** in the **AES_CTRL** register.
3. Load the **AES Initialization Vector Input n (AES_IV_IN_n)** registers at offset 0x040 to 0x04C.

Subsequence: Initialize CBC AES Core Mode

To configure CBC mode:

1. Enable CBC Mode by setting the **MODE** bit in the **AES_CTRL** register.
2. Load the **AES Initialization Vector Input n (AES_IV_IN_n)** registers at offset 0x040 to 0x04C.

13.4.1.3 Operational Modes Configuration

AES Polling Mode

Main Sequence: AES Polling Mode

Figure 13-12 on page 982 shows AES polling mode. The registers used in AES polling mode are:

- AES Data RW Plaintext/Ciphertext 0 (AES_DATA_IN_0) registers, offset 0x060 to 0x06C
- AES Control (AES_CTRL) register, offset 0x050
- AES Hash Tag Out 0 (AES_TAG_OUT_0), offset 0x070

Figure 13-12. AES Polling Mode

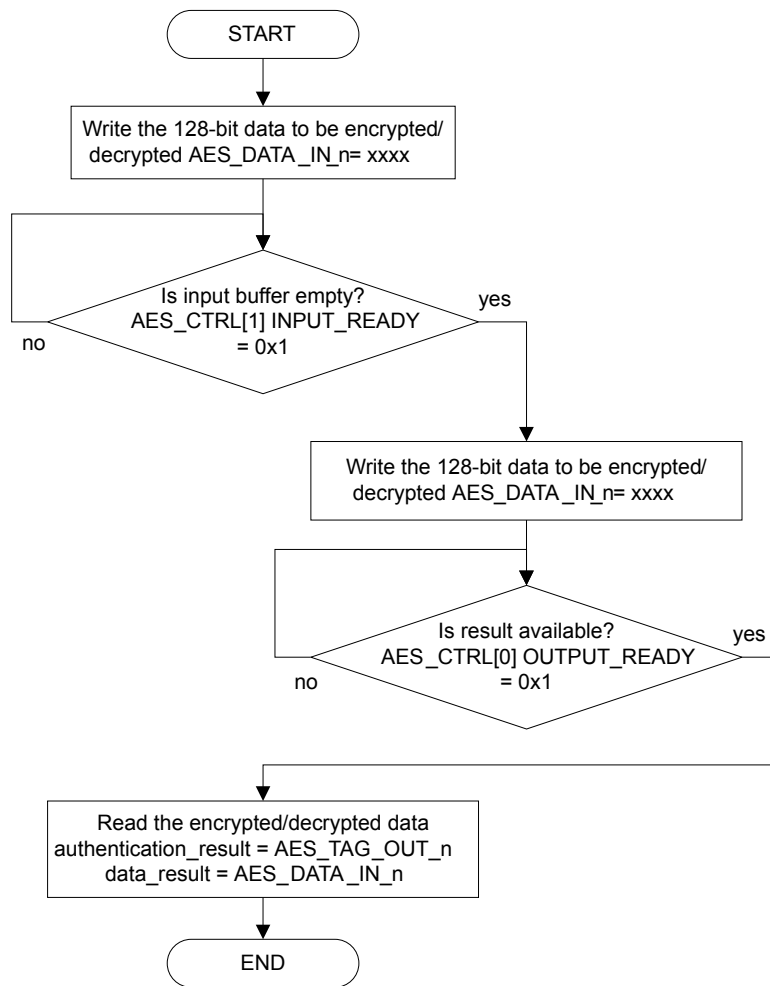

AES Interrupt Mode

The application can use software interrupts to control the flow of Context In, Context Out, Data In, and Data Out requests. To enable these interrupts:

1. Once the device has been initialized, following the initialization sequences described in “Global Initialization” on page 979 and “Initialization Subsequence” on page 980, the application can enable the AES module interrupts through the **AES Interrupt Enable (AES_IRQENABLE)** register, offset 0x090. If all four interrupts must be enabled, the application can write 0x0000.000F to the **AES_IRQENABLE** register.
2. Load the input buffers, **AES_DATA_IN_n**, with data.

Note: If the application uses Interrupt Mode, an interrupt is generated for each block of processed data. To support larger data flow, AES μ DMA Mode should be used and the bits in the **AES_IRQENABLE** register should be cleared.

AES DMA Mode

When AES DMA Mode is enabled, the **AES_IRQENABLE** register should be cleared. To enable the μ DMA to transfer data follow these steps:

1. Once the AES module has been initialized, enable the AES module μ DMA channels by programming the **DMA Channel Map Select n (DMACHMAPn)** register in the μ DMA module. Further μ DMA configuration guidelines are available in the “Micro Direct Memory Access (μ DMA)” on page 686.
2. Configure the dma_done interrupts by programming the **AES DMA Masked Interrupt Status (AES_DMAMIS)** register, at CCM offset 0x028.
3. Enable the μ DMA channels in the AES by programming the μ DMA enable bits in the **AES System Configuration (AES_SYSCONFIG)** register, offset 0x084.
4. The input buffer registers, **AES_DATA_IN_n**, at offsets 0x060 to 0x06C, are loaded.

13.4.1.4 AES Events Servicing

Interrupt Servicing

This section describes the event servicing of the module. Figure 13-13 on page 984 shows the AES interrupt service. The registers used during event servicing are:

- **AES_IRQSTATUS**
- **AES_KEY1_n**
- **AES_KEY2_n**
- **AES_IV_IN_n**
- **AES_DATA_IN_n**
- **AES_TAG_OUT_n**
- **AES_IRQENABLE**

Figure 13-13. AES Interrupt Service

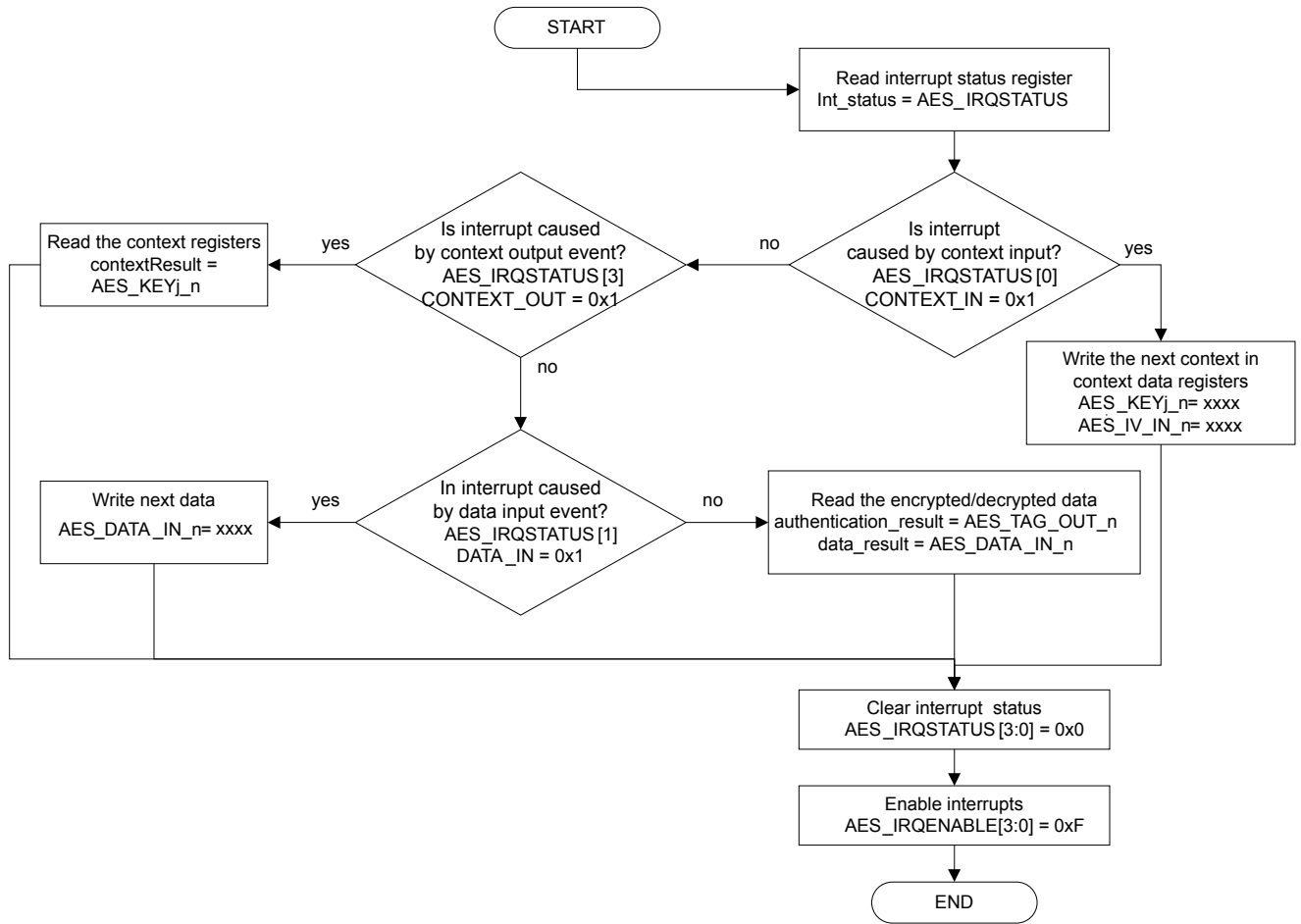

13.5 Register Map

Table 13-5 on page 984 lists the AES registers. The AES Module comprises registers that exist at an offset relative to the AES Module base address and a small set of AES μ DMA registers that exist at an offset relative to an Encryption Control Module base address. The AES Module register offsets are relative to the base address 0x4403.6000. The AES μ DMA interrupt registers are offset relative to the base address 0x4403.0000.

Table 13-5. AES Register Map

Offset	Name	Type	Reset	Description	See page
AES Module Registers (AES Module Offset)					
0x000	AES_KEY2_6	RW	0x0000.0000	AES Key 2_6	987
0x004	AES_KEY2_7	RW	0x0000.0000	AES Key 2_7	987
0x008	AES_KEY2_4	RW	0x0000.0000	AES Key 2_4	987

Table 13-5. AES Register Map (continued)

Offset	Name	Type	Reset	Description	See page
0x00C	AES_KEY2_5	RW	0x0000.0000	AES Key 2_5	987
0x010	AES_KEY2_2	RW	0x0000.0000	AES Key 2_2	987
0x014	AES_KEY2_3	RW	0x0000.0000	AES Key 2_3	987
0x018	AES_KEY2_0	RW	0x0000.0000	AES Key 2_0	987
0x01C	AES_KEY2_1	RW	0x0000.0000	AES Key 2_1	987
0x020	AES_KEY1_6	RW	0x0000.0000	AES Key 1_6	987
0x024	AES_KEY1_7	RW	0x0000.0000	AES Key 1_7	987
0x028	AES_KEY1_4	RW	0x0000.0000	AES Key 1_4	987
0x02C	AES_KEY1_5	RW	0x0000.0000	AES Key 1_5	987
0x030	AES_KEY1_2	RW	0x0000.0000	AES Key 1_2	987
0x034	AES_KEY1_3	RW	0x0000.0000	AES Key 1_3	987
0x038	AES_KEY1_0	RW	0x0000.0000	AES Key 1_0	987
0x03C	AES_KEY1_1	RW	0x0000.0000	AES Key 1_1	987
0x040	AES_IV_IN_0	RW	0x0000.0000	AES Initialization Vector Input 0	989
0x044	AES_IV_IN_1	RW	0x0000.0000	AES Initialization Vector Input 1	989
0x048	AES_IV_IN_2	RW	0x0000.0000	AES Initialization Vector Input 2	989
0x04C	AES_IV_IN_3	RW	0x0000.0000	AES Initialization Vector Input 3	989
0x050	AES_CTRL	RW	0x8000.0000	AES Control	990
0x054	AES_C_LENGTH_0	RW	0x0000.0000	AES Crypto Data Length 0	995
0x058	AES_C_LENGTH_1	RW	0x0000.0000	AES Crypto Data Length 1	995
0x05C	AES_AUTH_LENGTH	RW	0x0000.0000	AES Authentication Data Length	996
0x060	AES_DATA_IN_0	RW	0x0000.0000	AES Data RW Plaintext/Ciphertext 0	997
0x064	AES_DATA_IN_1	RW	0x0000.0000	AES Data RW Plaintext/Ciphertext 1	997
0x068	AES_DATA_IN_2	RW	0x0000.0000	AES Data RW Plaintext/Ciphertext 2	997
0x06C	AES_DATA_IN_3	RW	0x0000.0000	AES Data RW Plaintext/Ciphertext 3	997
0x070	AES_TAG_OUT_0	RW	0x0000.0000	AES Hash Tag Out 0	998
0x074	AES_TAG_OUT_1	RW	0x0000.0000	AES Hash Tag Out 1	998
0x078	AES_TAG_OUT_2	RW	0x0000.0000	AES Hash Tag Out 2	998
0x07C	AES_TAG_OUT_3	RW	0x0000.0000	AES Hash Tag Out 3	998
0x080	AES_REVISION	RO	0x00000041	AES IP Revision Identifier	999
0x084	AES_SYSCONFIG	RW	0x0000.0001	AES System Configuration	1000
0x088	AES_SYSSTATUS	RO	0x0000.0001	AES System Status	1003

Table 13-5. AES Register Map (continued)

Offset	Name	Type	Reset	Description	See page
0x08C	AES_IRQSTATUS	RO	0x0000.0000	AES Interrupt Status	1004
0x090	AES_IRQENABLE	RW	0x0000.0000	AES Interrupt Enable	1006
0x094	AES_DIRTYBITS	RW1C	0x0000.0000	AES Dirty Bits	1008
AES μDMA Interrupt Registers (CRC and Cryptographic Modules (CCM) Offset)					
0x020	AES_DMAIM	RW	0x0000.0000	AES DMA Interrupt Mask	1009
0x024	AES_DMARIS	RO	0x0000.0000	AES DMA Raw Interrupt Status	1011
0x028	AES_DMAMIS	RO	0x0000.0000	AES DMA Masked Interrupt Status	1013
0x02C	AES_DMAIC	W1C	0x0000.0000	AES DMA Interrupt Clear	1014

13.6 AES Register Descriptions

This section lists and describes the AES registers, in numerical order by address offset.

- Register 1: AES Key 2_6 (AES_KEY2_6), offset 0x000**
Register 2: AES Key 2_7 (AES_KEY2_7), offset 0x004
Register 3: AES Key 2_4 (AES_KEY2_4), offset 0x008
Register 4: AES Key 2_5 (AES_KEY2_5), offset 0x00C
Register 5: AES Key 2_2 (AES_KEY2_2), offset 0x010
Register 6: AES Key 2_3 (AES_KEY2_3), offset 0x014
Register 7: AES Key 2_0 (AES_KEY2_0), offset 0x018
Register 8: AES Key 2_1 (AES_KEY2_1), offset 0x01C
Register 9: AES Key 1_6 (AES_KEY1_6), offset 0x020
Register 10: AES Key 1_7 (AES_KEY1_7), offset 0x024
Register 11: AES Key 1_4 (AES_KEY1_4), offset 0x028
Register 12: AES Key 1_5 (AES_KEY1_5), offset 0x02C
Register 13: AES Key 1_2 (AES_KEY1_2), offset 0x030
Register 14: AES Key 1_3 (AES_KEY1_3), offset 0x034
Register 15: AES Key 1_0 (AES_KEY1_0), offset 0x038
Register 16: AES Key 1_1 (AES_KEY1_1), offset 0x03C

This register contains the 32-bit key data for the AES module. This value can be expanded to 256-bits depending on the mode of operation. Table 13-6 on page 987 describes the type of key that is held in register.

Note: Reads return zeros.

Table 13-6. AES Key Register Descriptions

Register Name	Address Offset	Description
AES_KEY2_6	0x000	Secure XTS second key / CBC-MAC third key
AES_KEY2_7	0x004	Secure XTS second key (MSW for 256-bit key) / CBC-MAC third key (MSW)
AES_KEY2_4	0x008	Secure XTS / CCM second key / CBC-MAC third key (LSW)
AES_KEY2_5	0x00C	Secure XTS second key (MSW for 192-bit key) / CBC-MAC third key
AES_KEY2_2	0x010	Secure XTS / CCM / CBC-MAC second key / Hash Key input
AES_KEY2_3	0x014	Secure XTS second key (MSW for 128-bit key) + CCM/CBC-MAC second key (MSW) / Hash Key input (MSW)
AES_KEY2_0	0x018	Secure XTS / CCM / CBC-MAC second key (LSW) / Hash Key input (LSW)
AES_KEY2_1	0x01C	Secure XTS / CCM / CBC-MAC second key / Hash Key input
AES_KEY1_6	0x020	Secure Key (LSW for 256-bit key)
AES_KEY1_7	0x024	Secure Key (MSW for 256-bit key)
AES_KEY1_4	0x028	Secure Key (LSW for 192-bit key)
AES_KEY1_5	0x02C	Secure Key (MSW for 192-bit key)

Table 13-6. AES Key Register Descriptions (continued)

Register Name	Address Offset	Description
AES_KEY1_2	0x030	Secure Key
AES_KEY1_3	0x034	Secure Key (MSW for 128-bit key)
AES_KEY1_0	0x038	Secure Key (LSW for 128-bit key)
AES_KEY1_1	0x03C	Secure Key

AES Key (AES_KEYn_n)

Base 0x4403.6000
 Offset 0x000
 Type RW, reset 0x0000.0000

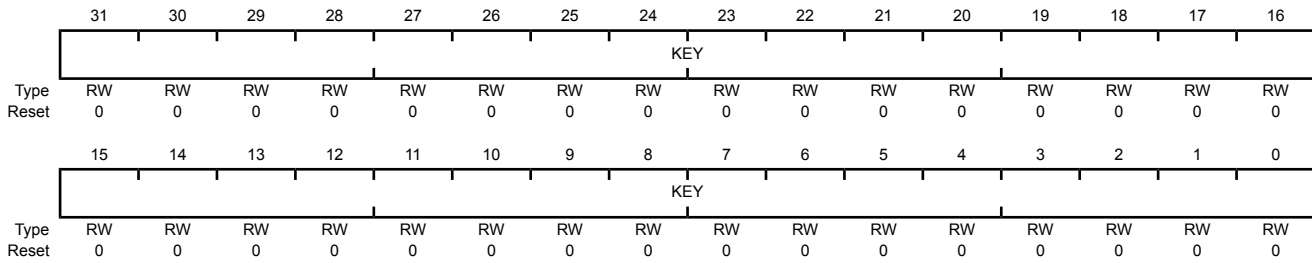

Bit/Field	Name	Type	Reset	Description
31:0	KEY	RW	0x00000000	Key Data This register contains the 32-bit key data for the AES module.

Register 17: AES Initialization Vector Input 0 (AES_IV_IN_0), offset 0x040

Register 18: AES Initialization Vector Input 1 (AES_IV_IN_1), offset 0x044

Register 19: AES Initialization Vector Input 2 (AES_IV_IN_2), offset 0x048

Register 20: AES Initialization Vector Input 3 (AES_IV_IN_3), offset 0x04C

This register contains the initialization vector input.

AES Initialization Vector Input (AES_IV_IN_n)

Base 0x4403.6000

Offset 0x040

Type RW, reset 0x0000.0000

	31	30	29	28	27	26	25	24	23	22	21	20	19	18	17	16
	DATA															
Type	RW	RW	RW	RW	RW	RW	RW	RW	RW	RW	RW	RW	RW	RW	RW	RW
Reset	0	0	0	0	0	0	0	0	0	0	0	0	0	0	0	0
	15	14	13	12	11	10	9	8	7	6	5	4	3	2	1	0
	DATA															
Type	RW	RW	RW	RW	RW	RW	RW	RW	RW	RW	RW	RW	RW	RW	RW	RW
Reset	0	0	0	0	0	0	0	0	0	0	0	0	0	0	0	0

Bit/Field	Name	Type	Reset	Description
31:0	DATA	RW	0x0000.0000	Initialization Vector Input This field contains the initialization input vector. The least significant word (LSW) is represented in register AES_IV_IN_0 and the most significant word is stored in AES_IV_IN_3

Register 21: AES Control (AES_CTRL), offset 0x050

This register determines the mode of operation of the AES Engine.

AES Control (AES_CTRL)

Base 0x4403.6000
 Offset 0x050
 Type RW, reset 0x8000.0000

	31	30	29	28	27	26	25	24	23	22	21	20	19	18	17	16
	CTXTRDY	SVCTXTRDY	SAVE_CONTEXT	reserved				CCM_M			CCM_L			CCM	GCM	
Type	RO	RO	RW	R	R	R	R	RW	RW	RW	RW	RW	RW	RW	RW	RW
Reset	1	0	0	0	0	0	0	0	0	0	0	0	0	0	0	0
	15	14	13	12	11	10	9	8	7	6	5	4	3	2	1	0
	CBCMAC	F9	F8	XTS		CFB	ICM	CTR_WIDTH		CTR	MODE	KEY_SIZE		DIRECTION	INPUT_READY	OUTPUT_READY
Type	RW	RW	RW	RW	RW	RW	RW	RW	RW	RW	RW	RW	RW	RW	RO	RO
Reset	0	0	0	0	0	0	0	0	0	0	0	0	0	0	0	0

Bit/Field	Name	Type	Reset	Description
31	CTXTRDY	RO	1	Context Data Registers Ready Value Description 0 The context data registers are not ready to be overwritten. 1 The context data registers can be overwritten and the host is permitted to write the next context.
30	SVCTXTRDY	RO	0	AES TAG/IV Block(s) Ready Note: This bit is only asserted if the SAVE_CONTEXT bit is set to 1. This bit is mutual exclusive with the CTXTRDY bit. Value Description 0 AES authentication TAG and/or IV block(s) is/are not available. 1 Indicates the AES authentication TAG and /or IV block(s) is/are available for the host to retrieve.
29	SAVE_CONTEXT	RW	0	TAG or Result IV Save If this bit is set, the CONTEXT_OUT interrupt bit is set in the AES_IRQSTATUS register if the operation is finished and related signals are enabled. Value Description 0 No effect. 1 Indicates an authentication TAG of result IV needs to be stored as a result context.

Bit/Field	Name	Type	Reset	Description														
28:25	reserved	R	0	Software should not rely on the value of a reserved bit. To provide compatibility with future products, the value of a reserved bit should be preserved across a read-modify-write operation.														
24:22	CCM_M	RW	0	Counter with CBC-MAC (CCM) Defines M which indicates the length of the authentication field for CCM operations; the authentication field length equals two times the sum of CCM-M plus one. Note: The AES Engine always returns a 128-bit authentication field, of which the M least significant bytes are valid. All values are supported.														
21:19	CCM_L	RW	0	L Value Defines L, which indicates the width of the length field for CCM operations; the length field in bytes equals the value of CMM-L plus one. Supported values for L are: <table border="1"> <thead> <tr> <th>Value</th> <th>Description</th> </tr> </thead> <tbody> <tr> <td>0x0</td> <td>width = 0</td> </tr> <tr> <td>0x1</td> <td>width = 2</td> </tr> <tr> <td>0x2</td> <td>reserved</td> </tr> <tr> <td>0x3</td> <td>width = 4</td> </tr> <tr> <td>0x4 - 0x6</td> <td>reserved</td> </tr> <tr> <td>0x7</td> <td>width = 8</td> </tr> </tbody> </table>	Value	Description	0x0	width = 0	0x1	width = 2	0x2	reserved	0x3	width = 4	0x4 - 0x6	reserved	0x7	width = 8
Value	Description																	
0x0	width = 0																	
0x1	width = 2																	
0x2	reserved																	
0x3	width = 4																	
0x4 - 0x6	reserved																	
0x7	width = 8																	
18	CCM	RW	0	AES-CCM Mode Enable <table border="1"> <thead> <tr> <th>Value</th> <th>Description</th> </tr> </thead> <tbody> <tr> <td>0</td> <td>AES-CCM mode is not enabled.</td> </tr> <tr> <td>1</td> <td>AES-CCM mode enabled. This is a combined mode, using AES for both authentication and encryption. No additional mode selection is required.</td> </tr> </tbody> </table>	Value	Description	0	AES-CCM mode is not enabled.	1	AES-CCM mode enabled. This is a combined mode, using AES for both authentication and encryption. No additional mode selection is required.								
Value	Description																	
0	AES-CCM mode is not enabled.																	
1	AES-CCM mode enabled. This is a combined mode, using AES for both authentication and encryption. No additional mode selection is required.																	
17:16	GCM	RW	0	AES-GCM Mode Enable This is a combined mode, using the Galois field-multiplier GF(2 ¹²⁸) for authentication and AES-CTR mode for encryption; the bits specify the GCM mode. <table border="1"> <thead> <tr> <th>Value</th> <th>Description</th> </tr> </thead> <tbody> <tr> <td>0x0</td> <td>No operation</td> </tr> <tr> <td>0x1</td> <td>GHASH with H loaded and Y0-encrypted forced to zero</td> </tr> <tr> <td>0x2</td> <td>GHASH with H loaded and Y0-encrypted calculated internally</td> </tr> <tr> <td>0x3</td> <td>Autonomous GHASH (both H and Y0-encrypted calculated internally)</td> </tr> </tbody> </table>	Value	Description	0x0	No operation	0x1	GHASH with H loaded and Y0-encrypted forced to zero	0x2	GHASH with H loaded and Y0-encrypted calculated internally	0x3	Autonomous GHASH (both H and Y0-encrypted calculated internally)				
Value	Description																	
0x0	No operation																	
0x1	GHASH with H loaded and Y0-encrypted forced to zero																	
0x2	GHASH with H loaded and Y0-encrypted calculated internally																	
0x3	Autonomous GHASH (both H and Y0-encrypted calculated internally)																	

Bit/Field	Name	Type	Reset	Description
15	CBCMAC	RW	0	<p>AES-CBC MAC Enable</p> <p>The <code>DIRECTION</code> bit must be set to 1 for this mode.</p> <p>Value Description</p> <p>0 AES-CBC MAC mode is not enabled.</p> <p>1 AES-CBC MAC mode enabled.</p>
14	F9	RW	0	<p>AES f9 Mode Enable</p> <p>The AES key size must be set to 128-bit for this mode.</p> <p>Value Description</p> <p>0 f9 mode is not enabled</p> <p>1 f9 mode is enabled.</p>
13	F8	RW	0	<p>AES f8 Mode Enable</p> <p>The <code>KEY_SIZE</code> must be set to 128-bit for this mode.</p> <p>Value Description</p> <p>0 AES f8 mode is not enabled.</p> <p>1 AES f8 mode is enabled.</p>
12:11	XTS	RW	0	<p>AES-XTS Operation Enabled</p> <p>The bits specify the XTS mode.</p> <p>Value Description</p> <p>0x0 No operation</p> <p>0x1 Previous/intermediate tweak value and j loaded (value is loaded via IV, j is loaded via the AAD length register)</p> <p>0x2 Key2, n and j are loaded (n is loaded via IV, j is loaded via the AAD length register)</p> <p>0x3 Key2 and n are loaded; j=0 (n is loaded via IV)</p>
10	CFB	RW	0	<p>Full block AES cipher feedback mode (CFB128) Enable</p> <p>Value Description</p> <p>0 AES-CFB mode is not enabled.</p> <p>1 AES-CFB mode is enabled.</p>
9	ICM	RW	0	<p>AES Integer Counter Mode (ICM) Enable</p> <p>This is a counter mode with a 16-bit wide counter.</p> <p>Value Description</p> <p>0 AES-ICM mode is not enabled.</p> <p>1 AES-ICM mode is enabled.</p>

Bit/Field	Name	Type	Reset	Description
8:7	CTR_WIDTH	RW	0	<p>AES-CTR Mode Counter Width</p> <p>Value Description</p> <p>0x0 Counter is 32 bits</p> <p>0x1 Counter is 64 bits</p> <p>0x2 Counter is 96 bits</p> <p>0x3 Counter is 128 bits</p>
6	CTR	RW	0	<p>Counter Mode</p> <p>This bit must also be set for GCM and CCM mode, when encryption/decryption is required.</p> <p>Value Description</p> <p>0 Counter mode is not enabled.</p> <p>1 Counter mode is enabled.</p>
5	MODE	RW	0	<p>ECB/CBC Mode</p> <p>Value Description</p> <p>0 ECB mode</p> <p>1 CBC mode</p>
4:3	KEY_SIZE	RW	0	<p>Key Size</p> <p>Value Description</p> <p>0x0 reserved</p> <p>0x1 Key is 128 bits</p> <p>0x2 Key is 192 bits</p> <p>0x3 Key is 256 bits</p>
2	DIRECTION	RW	0	<p>Encryption/Decryption Selection</p> <p>If set to <code>DIRECTION=1</code>, an encrypt operation is performed. If set to 0, a decrypt operation is performed.</p> <p>Value Description</p> <p>0 Decryption is selected.</p> <p>1 Encryption is selected.</p>
1	INPUT_READY	RO	0	<p>Input Ready Status</p> <p>Value Description</p> <p>0 Input buffer is not empty.</p> <p>1 Indicates that the 16-byte input buffer is empty, and the host is permitted to write the next block of data.</p>

Bit/Field	Name	Type	Reset	Description
0	OUTPUT_READY	RO	0	Output Ready Status
				Value Description
			0	No AES output block is available.
			1	An AES output block is available for the host to retrieve.

Register 22: AES Crypto Data Length 0 (AES_C_LENGTH_0), offset 0x054**Register 23: AES Crypto Data Length 1 (AES_C_LENGTH_1), offset 0x058**

AES Crypto Data Length n (AES_C_LENGTH_n) registers (LSW and MSW) store the cryptographic data length in bytes for all modes. The **AES_C_LENGTH_0** register stores the most significant word and the **AES_C_LENGTH_1** register stores the least significant word. Once processing with this context is started, this length decrements to zero. Data lengths up to $(2^{61} - 1)$ bytes are allowed. For GCM, any value up to 236 - 32 bytes can be used. This is because a 32-bit counter mode is used; the maximum number of 128-bit blocks is $2^{32} - 2$, resulting in a maximum number of bytes of $2^{36} - 32$. A write to this register triggers the engine to start using this context. This is valid for all modes except GCM and CCM. Note that for the combined modes, this length does not include the authentication only data; the authentication length is specified in the **AES_AUTH_LENGTH** register below. All modes must have a length greater than 0. For the combined modes, it is permissible to have one of the lengths equal to zero. For the basic encryption modes (ECB/CBC/CTR/ICM/CFB128) it is permissible to program zero to the length field; in that case the length is assumed infinite. All data must be byte (8-bit) aligned; bit aligned data streams are not supported by the AES Engine.

Note: For a Host read operation, these registers return all zeroes.

AES Crypto Data Length (AES_C_LENGTH_n)

Base 0x4403.6000
Offset 0x054
Type RW, reset 0x0000.0000

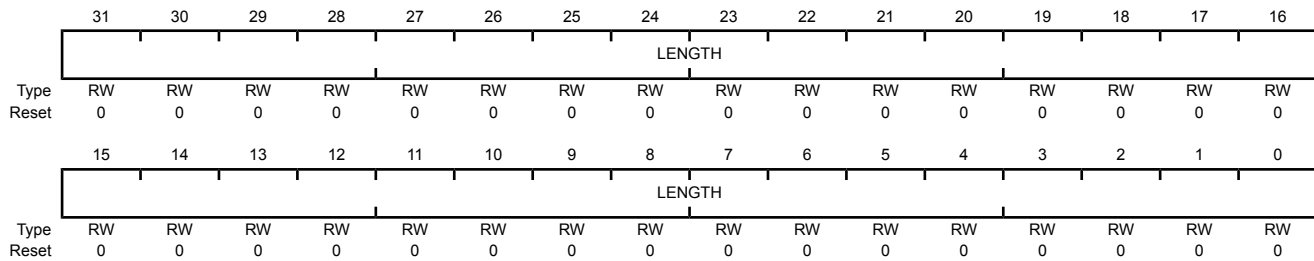

Bit/Field	Name	Type	Reset	Description
31:0	LENGTH	RW	0x00000000	Data Length This field stores the cryptographic data length in bytes for all modes.

Register 24: AES Authentication Data Length (AES_AUTH_LENGTH), offset 0x05C

The **AES Authentication Data Length (AES_AUTH_LENGTH)** register stores the authentication data length in bytes for combined modes only (GCM or CCM). Supported `AUTH` lengths for CCM are from 0 to $(2^{16} - 28)$ bytes. For GCM any value up to $(2^{32} - 1)$ bytes can be used. Once processing with this context is started, this length decrements to zero. A write to this register triggers the engine to start using this context for GCM and CCM. For XTS, this register is optionally used to load `j`. Loading of `j` is only required if `j` \neq 0. `j` is a 28-bit value and must be written to bits [31-4] of this register. `j` represents the sequential number of the 128-bit block inside the data unit. For the first block in a unit, this value is zero. It is not required to provide a `j` for each new data block within a unit. Note that it is possible to start with a `j` unequal to zero.

Note: For a Host read operation, these registers return all-zeroes..

AES Authentication Data Length (AES_AUTH_LENGTH)

Base 0x4403.6000
 Offset 0x05C
 Type RW, reset 0x0000.0000

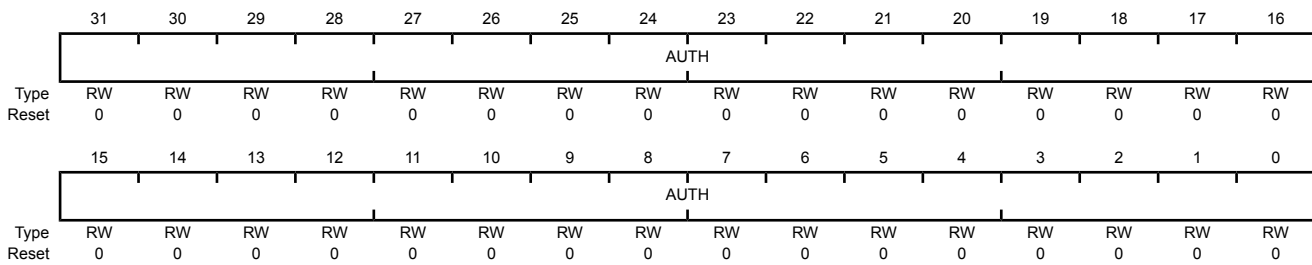

Bit/Field	Name	Type	Reset	Description
31:0	AUTH	RW	0x00000000	Authentication Data Length This field stores the authentication data length in bytes for combined modes (GCM or CCM).

Register 25: AES Data RW Plaintext/Ciphertext 0 (AES_DATA_IN_0), offset 0x060

Register 26: AES Data RW Plaintext/Ciphertext 1 (AES_DATA_IN_1), offset 0x064

Register 27: AES Data RW Plaintext/Ciphertext 2 (AES_DATA_IN_2), offset 0x068

Register 28: AES Data RW Plaintext/Ciphertext 3 (AES_DATA_IN_3), offset 0x06C

The **AES Data RW Plaintext/Ciphertext n (AES_DATA_IN_n)** registers are used to read and write plaintext/ciphertext. The **AES_DATA_IN_0** register contains the most significant word; the **AES_DATA_IN_3** register contains least significant word.

Note: The **AES_DATA_IN_0** register acts as a FIFO and shifts data into the other **AES_DATA_IN_n** registers.

AES Data RW Plaintext/Ciphertext (AES_DATA_IN_n)

Base 0x4403.6000
Offset 0x060
Type RW, reset 0x0000.0000

	31	30	29	28	27	26	25	24	23	22	21	20	19	18	17	16
	DATA															
Type	RW	RW	RW	RW	RW	RW	RW	RW	RW	RW	RW	RW	RW	RW	RW	RW
Reset	0	0	0	0	0	0	0	0	0	0	0	0	0	0	0	0
	15	14	13	12	11	10	9	8	7	6	5	4	3	2	1	0
	DATA															
Type	RW	RW	RW	RW	RW	RW	RW	RW	RW	RW	RW	RW	RW	RW	RW	RW
Reset	0	0	0	0	0	0	0	0	0	0	0	0	0	0	0	0

Bit/Field	Name	Type	Reset	Description
31:0	DATA	RW	0x00000000	Secure Data RW Plaintext/Ciphertext This field holds the plaintext/ciphertext data.

Register 29: AES Hash Tag Out 0 (AES_TAG_OUT_0), offset 0x070

Register 30: AES Hash Tag Out 1 (AES_TAG_OUT_1), offset 0x074

Register 31: AES Hash Tag Out 2 (AES_TAG_OUT_2), offset 0x078

Register 32: AES Hash Tag Out 3 (AES_TAG_OUT_3), offset 0x07C

This register displays the Hash result. The **AES_TAG_OUT_0** register is the most significant word of the Hash and the **AES_TAG_OUT_3** register is the least significant word.

AES Hash Tag Out (AES_TAG_OUT_n)

Base 0x4403.6000
 Offset 0x070
 Type RW, reset 0x0000.0000

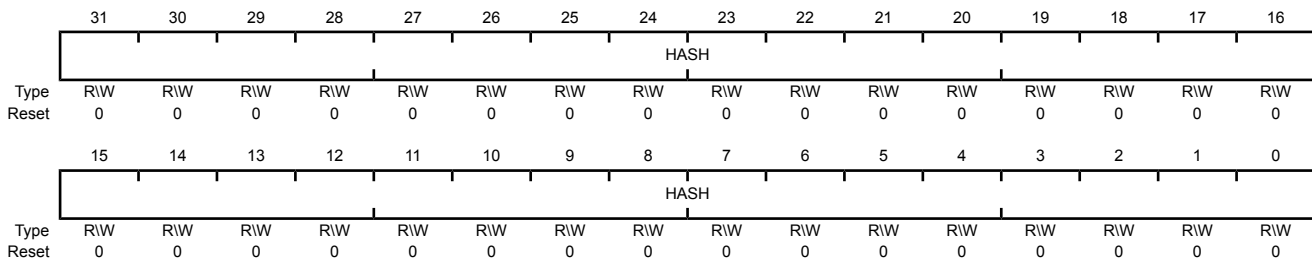

Bit/Field	Name	Type	Reset	Description
31:0	HASH	RW	0x00000000	Hash Result This field holds the hash result.

Register 33: AES IP Revision Identifier (AES_REVISION), offset 0x080

This register contains the IP revision number of the AES.

AES IP Revision Identifier (AES_REVISION)

Base 0x4403.6000

Offset 0x080

Type RO, reset 0x00000041

	31	30	29	28	27	26	25	24	23	22	21	20	19	18	17	16
	REVISION															
Type	RO	RO	RO	RO	RO	RO	RO	RO	RO	RO	RO	RO	RO	RO	RO	RO
Reset	0	0	0	0	0	0	0	0	0	0	0	0	0	0	0	0
	15	14	13	12	11	10	9	8	7	6	5	4	3	2	1	0
	REVISION															
Type	RO	RO	RO	RO	RO	RO	RO	RO	RO	RO	RO	RO	RO	RO	RO	RO
Reset	0	0	0	0	0	0	0	0	0	1	0	0	0	0	0	1

Bit/Field	Name	Type	Reset	Description
31:0	REVISION	RO	0x00000041	Revision number

Register 34: AES System Configuration (AES_SYSCONFIG), offset 0x084

This register controls the IDLE and reset logic.

Note: After one operation has completed, the **AES_SYSCONFIG** register must be cleared and re-configured for the next operation to ensure proper DMA and data operation functionality.

AES System Configuration (AES_SYSCONFIG)

Base 0x4403.6000
 Offset 0x084
 Type RW, reset 0x0000.0001

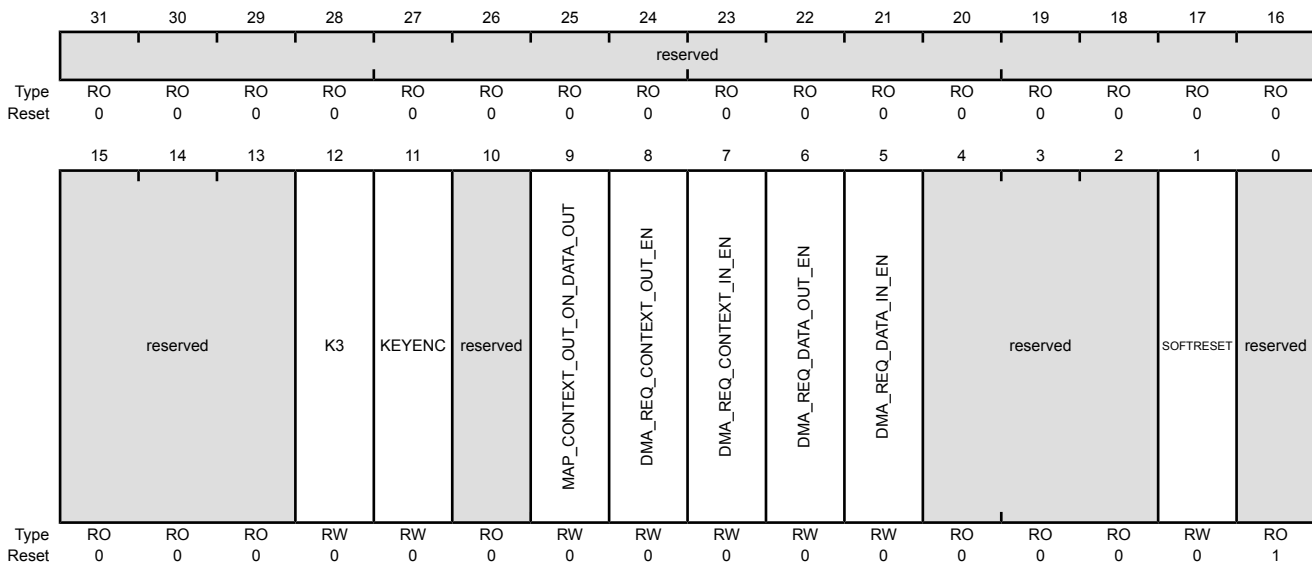

Bit/Field	Name	Type	Reset	Description
31:13	reserved	RO	0	Software should not rely on the value of a reserved bit. To provide compatibility with future products, the value of a reserved bit should be preserved across a read-modify-write operation.
12	K3	RW	0	K3 Select Value Description 0 A regular cryptographic operation is performed. 1 The K3 key is used as the key for the selected cryptographic operation. The key size should be 128-bits. This bit may only be set to one if the KEYENC bit of this register is cleared to zero.
11	KEYENC	RW	0	Key Encoding Value Description 0 A regular cryptographic operation is performed 1 The KEK key (see KEKMODE bit) is XOR-ed with a predefined constant value before it is used as a key for the selected cryptographic operation.

Bit/Field	Name	Type	Reset	Description
10	reserved	RO	0	Software should not rely on the value of a reserved bit. To provide compatibility with future products, the value of a reserved bit should be preserved across a read-modify-write operation.
9	MAP_CONTEXT_OUT_ON_DATA_OUT	RW	0	Map Context Out on Data Out Enable Value Description 0 Original context out bit values are used. 1 The DMA_REQ_CONTEXT_OUT_EN bit in this register and the CONTEXT_OUT bit in the AES_IRQENABLE register are mapped on the corresponding DATA_OUT request bits. In this case, the original CONTEXT_OUT bit values are ignored.
8	DMA_REQ_CONTEXT_OUT_EN	RW	0	DMA Request Context Out Enable If set to '1', the DMA context output request is enabled (for context data out, for example, TAG for authentication modes). The dma_done indication bits in AES_DMARIS register, at CCM module offset 0x024, identify to the application when the DMA transfer is complete. Value Description 0 DMA disabled for context output request. 1 DMA enabled for context output request.
7	DMA_REQ_CONTEXT_IN_EN	RW	0	DMA Request Context In Enable The dma_done indication bits in AES_DMARIS register, at CCM offset 0x024, identify to the application when the DMA transfer is complete. Value Description 0 DMA disabled for context input request. 1 DMA enabled for context input request.
6	DMA_REQ_DATA_OUT_EN	RW	0	DMA Request Data Out Enable The dma_done indication bits in AES_DMARIS register, at CCM offset 0x024, identify to the application when the DMA transfer is complete. Value Description 0 DMA disabled for data output request. 1 DMA enabled for data output request.
5	DMA_REQ_DATA_IN_EN	RW	0	DMA Request Data In Enable The dma_done indication bits in AES_DMARIS register, at CCM module offset 0x024, identify to the application when the DMA transfer is complete. Value Description 0 DMA disabled for data input request. 1 DMA enabled for data input request.

Bit/Field	Name	Type	Reset	Description
4:2	reserved	RO	0	Software should not rely on the value of a reserved bit. To provide compatibility with future products, the value of a reserved bit should be preserved across a read-modify-write operation.
1	SOFTRESET	RW	0	Soft reset Value Description 0 No operation 1 Start soft reset sequence
0	reserved	RO	1	Software should not rely on the value of a reserved bit. To provide compatibility with future products, the value of a reserved bit should be preserved across a read-modify-write operation.

Register 35: AES System Status (AES_SYSSTATUS), offset 0x088

This register indicates if reset has completed.

AES System Status (AES_SYSSTATUS)

Base 0x4403.6000

Offset 0x088

Type RO, reset 0x0000.0001

	31	30	29	28	27	26	25	24	23	22	21	20	19	18	17	16
	reserved															
Type	RO	RO	RO	RO	RO	RO	RO	RO	RO	RO	RO	RO	RO	RO	RO	RO
Reset	0	0	0	0	0	0	0	0	0	0	0	0	0	0	0	0
	15	14	13	12	11	10	9	8	7	6	5	4	3	2	1	0
	reserved															RESETDONE
Type	RO	RO	RO	RO	RO	RO	RO	RO	RO	RO	RO	RO	RO	RO	RO	RO
Reset	0	0	0	0	0	0	0	0	0	0	0	0	0	0	0	1

Bit/Field	Name	Type	Reset	Description
31:1	reserved	RO	0	Software should not rely on the value of a reserved bit. To provide compatibility with future products, the value of a reserved bit should be preserved across a read-modify-write operation.
0	RESETDONE	RO	1	Reset Done
				Value Description
				0 Reset is not complete.
				1 Reset is has completed.

Register 36: AES Interrupt Status (AES_IRQSTATUS), offset 0x08C

This register indicates the interrupt status. If one of the interrupt bits is set, the interrupt output is asserted.

AES Interrupt Status (AES_IRQSTATUS)

Base 0x4403.6000
 Offset 0x08C
 Type RO, reset 0x0000.0000

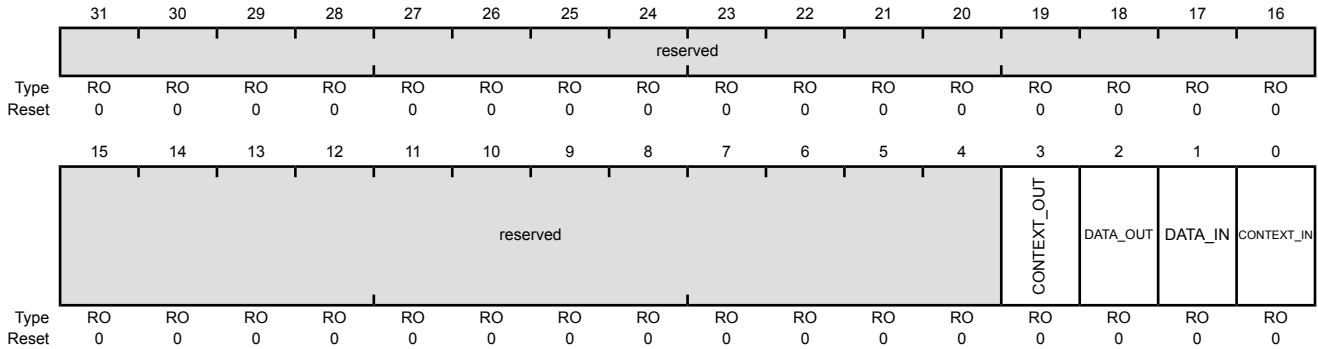

Bit/Field	Name	Type	Reset	Description
31:4	reserved	RO	0	Software should not rely on the value of a reserved bit. To provide compatibility with future products, the value of a reserved bit should be preserved across a read-modify-write operation.
3	CONTEXT_OUT	RO	0	Context Output Interrupt Status Value Description 0 Authentication tag (and IV) interrupt(s) is/are not active. 1 Authentication tag (and IV) interrupt(s) is/are active and the interrupt output has been triggered.
2	DATA_OUT	RO	0	Data Out Interrupt Status Value Description 0 The data out interrupt is not active. 1 The data out interrupt is active and the interrupt output has been triggered.
1	DATA_IN	RO	0	Data In Interrupt Status Value Description 0 The data in interrupt is not active. 1 The data in interrupt is active and the interrupt output has been triggered.

Bit/Field	Name	Type	Reset	Description
0	CONTEXT_IN	RO	0	Context In Interrupt Status
				Value Description
				0 The context in interrupt is not active.
				1 The context in interrupt is active and the interrupt output has been triggered.

Register 37: AES Interrupt Enable (AES_IRQENABLE), offset 0x090

This register contains an enable bit for each unique interrupt generated by the module. It matches the layout of **AES_IRQSTATUS** register. An interrupt is enabled when the bit in this register is set to 1. An interrupt that is enabled is propagated to the NVIC controller. All AES software interrupts need to be enabled explicitly by writing this register.

Note: If the application uses Interrupt Mode, an interrupt is generated for each block of processed data. To support larger data flow, AES μ DMA Mode should be used and the bits in the **AES_IRQENABLE** register should be cleared.

AES Interrupt Enable (AES_IRQENABLE)

Base 0x4403.6000
 Offset 0x090
 Type RW, reset 0x0000.0000

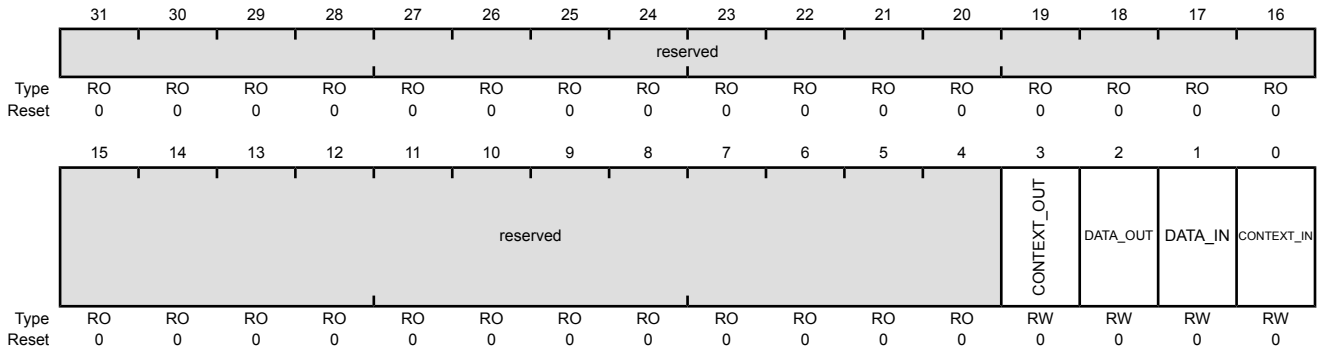

Bit/Field	Name	Type	Reset	Description
31:4	reserved	RO	0	Software should not rely on the value of a reserved bit. To provide compatibility with future products, the value of a reserved bit should be preserved across a read-modify-write operation.
3	CONTEXT_OUT	RW	0	Context Out Interrupt Enable Value Description 0 Authentication tag (and IV) interrupt(s) is/are disabled. 1 Authentication tag (and IV) interrupt(s) is/are enabled.
2	DATA_OUT	RW	0	Data Out Interrupt Enable Value Description 0 The data out interrupt is disabled. 1 The data out interrupt is enabled.
1	DATA_IN	RW	0	Data In Interrupt Enable Value Description 0 The data in interrupt is disabled. 1 The data in interrupt is enabled.

Bit/Field	Name	Type	Reset	Description
0	CONTEXT_IN	RW	0	Context In Interrupt Enable
				Value Description
				0 The context in interrupt is disabled.
				1 The context in interrupt is enabled.

Register 38: AES Dirty Bits (AES_DIRTYBITS), offset 0x094

This register can be used to identify if AES registers have been read or written to.

AES Dirty Bits (AES_DIRTYBITS)

Base 0x4403.6000
 Offset 0x094
 Type RW1C, reset 0x0000.0000

	31	30	29	28	27	26	25	24	23	22	21	20	19	18	17	16
	reserved															
Type	R	R	R	R	R	R	R	R	R	R	R	R	R	R	R	R
Reset	0	0	0	0	0	0	0	0	0	0	0	0	0	0	0	0
	15	14	13	12	11	10	9	8	7	6	5	4	3	2	1	0
	reserved														S_DIRTY	S_ACCESS
Type	R	R	R	R	R	R	R	R	R	R	R	R	R	R	RW1C	RW1C
Reset	0	0	0	0	0	0	0	0	0	0	0	0	0	0	0	0

Bit/Field	Name	Type	Reset	Description
31:2	reserved	R	0	Software should not rely on the value of a reserved bit. To provide compatibility with future products, the value of a reserved bit should be preserved across a read-modify-write operation.
1	S_DIRTY	RW1C	0	AES Dirty Bit This bit must be written to a 1 to clear. Value Description 0 No AES registers have been written. 1 Indicates when any of the AES_x registers have been written (except for the AES_DIRTYBITS register).
0	S_ACCESS	RW1C	0	AES Access Bit This bit must be written to a 1 to clear. Value Description 0 No AES registers have been read. 1 Indicates when any of the AES_x registers have been read (except for the AES_DIRTYBITS register).

13.7 AES µDMA Interrupt Register Descriptions (CCM Offset)

This section lists and describes the AES µDMA registers, in numerical order by address offset. Registers in this section are relative to the base address of 0x4403.0000.

Register 39: AES DMA Interrupt Mask (AES_DMAIM), offset 0x020

The **AES DMA Interrupt Mask (AES_DMAIM)** register controls interrupt behavior and is used to program which interrupts are suppressed.

AES DMA Interrupt Mask (AES_DMAIM)

Base 0x4403.0000
Offset 0x020
Type RW, reset 0x0000.0000

	31	30	29	28	27	26	25	24	23	22	21	20	19	18	17	16	
	reserved																
Type	RO	RO	RO	RO	RO	RO	RO	RO	RO	RO	RO	RO	RO	RO	RO	RO	
Reset	0	0	0	0	0	0	0	0	0	0	0	0	0	0	0	0	
	15	14	13	12	11	10	9	8	7	6	5	4	3	2	1	0	
	reserved												DOUT	DIN	COUT	CIN	
Type	RO	RO	RO	RO	RO	RO	RO	RO	RO	RO	RO	RO	RO	RW	RW	RW	RW
Reset	0	0	0	0	0	0	0	0	0	0	0	0	0	0	0	0	0

Bit/Field	Name	Type	Reset	Description				
31:4	reserved	RO	0x0000.000	Software should not rely on the value of a reserved bit. To provide compatibility with future products, the value of a reserved bit should be preserved across a read-modify-write operation.				
3	DOUT	RW	0	<p>Data Out DMA Done Interrupt Mask</p> <p>If this bit is unmasked, an interrupt is generated when the μDMA writes the last word of the process result.</p> <p>Value Description</p> <table border="0"> <tr> <td>0</td> <td>The <code>DOUT</code> interrupt is suppressed and not sent to the interrupt controller.</td> </tr> <tr> <td>1</td> <td>The <code>DOUT</code> interrupt is sent to the interrupt controller.</td> </tr> </table>	0	The <code>DOUT</code> interrupt is suppressed and not sent to the interrupt controller.	1	The <code>DOUT</code> interrupt is sent to the interrupt controller.
0	The <code>DOUT</code> interrupt is suppressed and not sent to the interrupt controller.							
1	The <code>DOUT</code> interrupt is sent to the interrupt controller.							
2	DIN	RW	0	<p>Data In DMA Done Interrupt Mask</p> <p>If this bit is unmasked, an interrupt is generated when the μDMA writes the last word of input data to the internal FIFO of the engine.</p> <p>Value Description</p> <table border="0"> <tr> <td>0</td> <td>The <code>DIN</code> interrupt is suppressed and not sent to the interrupt controller.</td> </tr> <tr> <td>1</td> <td>The <code>DIN</code> interrupt is sent to the interrupt controller.</td> </tr> </table>	0	The <code>DIN</code> interrupt is suppressed and not sent to the interrupt controller.	1	The <code>DIN</code> interrupt is sent to the interrupt controller.
0	The <code>DIN</code> interrupt is suppressed and not sent to the interrupt controller.							
1	The <code>DIN</code> interrupt is sent to the interrupt controller.							
1	COUT	RW	0	<p>Context Out DMA Done Interrupt Mask</p> <p>If this bit is unmasked, an interrupt is generated when the μDMA completes the output context read from the internal register.</p> <p>Value Description</p> <table border="0"> <tr> <td>0</td> <td>The <code>COUT</code> interrupt is suppressed and not sent to the interrupt controller.</td> </tr> <tr> <td>1</td> <td>The <code>COUT</code> interrupt is sent to the interrupt controller.</td> </tr> </table>	0	The <code>COUT</code> interrupt is suppressed and not sent to the interrupt controller.	1	The <code>COUT</code> interrupt is sent to the interrupt controller.
0	The <code>COUT</code> interrupt is suppressed and not sent to the interrupt controller.							
1	The <code>COUT</code> interrupt is sent to the interrupt controller.							

Bit/Field	Name	Type	Reset	Description
0	CIN	RW	0	<p>Context In DMA Done Interrupt Mask</p> <p>If this bit is unmasked, an interrupt is generated when the μDMA completes a context write to the internal register.</p> <p>Value Description</p> <p>0 The CIN interrupt is suppressed and not sent to the interrupt controller.</p> <p>1 The CIN interrupt is sent to the interrupt controller.</p>

Register 40: AES DMA Raw Interrupt Status (AES_DMARIS), offset 0x024

The **AES DMA Raw Interrupt Status (AES_DMARIS)** register contains the raw interrupt status. If any of these bits read 1, the processor is interrupted if the corresponding masked interrupt status bit is set to '1.'

AES DMA Raw Interrupt Status (AES_DMARIS)

Base 0x4403.0000

Offset 0x024

Type RO, reset 0x0000.0000

	31	30	29	28	27	26	25	24	23	22	21	20	19	18	17	16	
	reserved																
Type	RO	RO	RO	RO	RO	RO	RO	RO	RO	RO	RO	RO	RO	RO	RO	RO	
Reset	0	0	0	0	0	0	0	0	0	0	0	0	0	0	0	0	
	15	14	13	12	11	10	9	8	7	6	5	4	3	2	1	0	
	reserved												DOUT	DIN	COUT	CIN	
Type	RO	RO	RO	RO	RO	RO	RO	RO	RO	RO	RO	RO	RO	RW	RW	RW	RW
Reset	0	0	0	0	0	0	0	0	0	0	0	0	0	0	0	0	0

Bit/Field	Name	Type	Reset	Description
31:4	reserved	RO	0x0000.000	Software should not rely on the value of a reserved bit. To provide compatibility with future products, the value of a reserved bit should be preserved across a read-modify-write operation.
3	DOUT	RW	0	Data Out DMA Done Raw Interrupt Status Value Description 0 No Interrupt. 1 The μ DMA has written the last word of the process result and an interrupt has been triggered and is pending.
2	DIN	RW	0	Data In DMA Done Raw Interrupt Status Value Description 0 No Interrupt. 1 The μ DMA has written the last word of input data to the internal FIFO of the engine and an interrupt has been triggered and is pending.
1	COUT	RW	0	Context Out DMA Done Raw Interrupt Status Value Description 0 No Interrupt. 1 The μ DMA has completed the output context read from the internal register and an interrupt has been triggered and is pending.

Bit/Field	Name	Type	Reset	Description
0	CIN	RW	0	Context In DMA Done Raw Interrupt Status
				Value Description
				0 No interrupt.
				1 The μ DMA has completed a context write to the internal register and an interrupt has been triggered and is pending.

Register 41: AES DMA Masked Interrupt Status (AES_DMAMIS), offset 0x028

The **AES DMA Masked Interrupt Status (AES_DMAMIS)** register displays the raw interrupts that are unmasked in the **AES DMA Raw Interrupt Status (AES_DMARIS)** register.

AES DMA Masked Interrupt Status (AES_DMAMIS)

Base 0x4403.0000

Offset 0x028

Type RO, reset 0x0000.0000

	31	30	29	28	27	26	25	24	23	22	21	20	19	18	17	16	
	reserved																
Type	RO	RO	RO	RO	RO	RO	RO	RO	RO	RO	RO	RO	RO	RO	RO	RO	
Reset	0	0	0	0	0	0	0	0	0	0	0	0	0	0	0	0	
	15	14	13	12	11	10	9	8	7	6	5	4	3	2	1	0	
	reserved													DOUT	DIN	COUT	CIN
Type	RO	RO	RO	RO	RO	RO	RO	RO	RO	RO	RO	RO	RO	RO	RO	RO	
Reset	0	0	0	0	0	0	0	0	0	0	0	0	0	0	0	0	

Bit/Field	Name	Type	Reset	Description
31:4	reserved	RO	0x0000.000	Software should not rely on the value of a reserved bit. To provide compatibility with future products, the value of a reserved bit should be preserved across a read-modify-write operation.
3	DOUT	RO	0	Data Out DMA Done Masked Interrupt Status Value Description 0 An interrupt has not occurred or is masked. 1 A DOUT interrupt has occurred.
2	DIN	RO	0	Data In DMA Done Masked Interrupt Status Value Description 0 An interrupt has not occurred or is masked. 1 A DIN interrupt has occurred.
1	COUT	RO	0	Context Out DMA Done Masked Interrupt Status Value Description 0 An interrupt has not occurred or is masked. 1 A COUT interrupt has occurred.
0	CIN	RO	0	Context In DMA Done Raw Interrupt Status Value Description 0 An interrupt has not occurred or is masked. 1 A CIN interrupt has occurred.

Register 42: AES DMA Interrupt Clear (AES_DMAIC), offset 0x02C

The **AES DMA Interrupt Clear (AES_DMAIC)** register is used to clear the **AES_DMARIS** and **AES_DMAMIS** registers by writing a 1 to each register bit.

Note: This registers always reads as zero.

AES DMA Interrupt Clear (AES_DMAIC)

Base 0x4403.0000
 Offset 0x02C
 Type W1C, reset 0x0000.0000

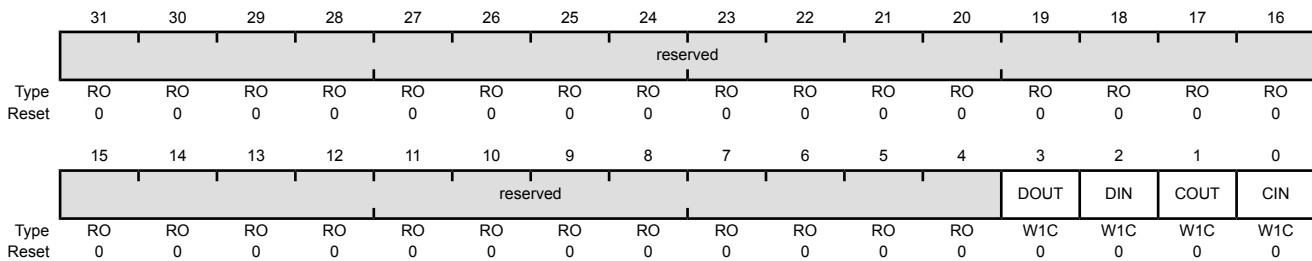

Bit/Field	Name	Type	Reset	Description
31:4	reserved	RO	0x0000.000	Software should not rely on the value of a reserved bit. To provide compatibility with future products, the value of a reserved bit should be preserved across a read-modify-write operation.
3	DOUT	W1C	0	Data Out DMA Done Interrupt Clear Writing a 1 to this bit clears the DOUT bit in the AES_DMARIS and AES_DMAMIS register.
2	DIN	W1C	0	Data In DMA Done Interrupt Clear Writing a 1 to this bit clears the DIN bit in the AES_DMARIS and AES_DMAMIS register.
1	COUT	W1C	0	Context Out DMA Done Masked Interrupt Status Writing a 1 to this bit clears the COUT bit in the AES_DMARIS and AES_DMAMIS register.
0	CIN	W1C	0	Context In DMA Done Raw Interrupt Status Writing a 1 to this bit clears the CIN bit in the AES_DMARIS and AES_DMAMIS register.

14 Data Encryption Standard Accelerator (DES)

The DES module provides hardware accelerated data encryption and decryption functions. The module runs either the single DES or the triple DES (3DES) algorithm in compliance with the [FIPS 46-3 standard](#) and supports electronic codebook (ECB), cipher block chaining (CBC), and cipher feedback (CFB) modes of operation. It does not support the output feedback (OFB) mode of operation in hardware.

The purpose of the DES algorithm is to encrypt (encipher) or decrypt (decipher) binary coded information. Encrypting data converts it to an unintelligible form called cipher text. Decrypting cipher text converts the data back to its original form called plaintext. DES is a symmetrical algorithm in that the encryption and decryption keys are identical. Each triple DES encrypt/decrypt operation is a compound of DES encrypt and decrypt operations.

The DES accelerator includes the following main features:

- DES/3DES encryption and decryption.
- Feedback modes: ECB, CBC, CFB
- Host interrupt or μ DMA driven modes of operation. μ DMA support for data and context in/result out
- Fully synchronous design
- Internal wide-bus interface

14.1 DES Functional Description

The DES module is an efficient implementation of a DES block cipher. Block ciphers, as opposed to stream ciphers, operate on blocks of plain text and cipher text. The DES block size is 8-byte. The DES key consists of 64 binary digits, but only 56 bits are actually used directly by the algorithm. The other 8 bits are used for error detection.

The 64-bit block of input data to be enciphered is initially permuted, then passed through 16 iterations of a calculation that uses a cipher function and finally permuted to the inverse of the initial permutation. At each of the 16 iterations, a 48-bit key computed from the 64-bit input key is applied to one of the 32-bit sub-blocks of the 64-bit input block using the cipher function. The 48-bit key value changes for each iteration. The result of the cipher function is a 32-bit sub-block, which is concatenated with the second 32-bit input sub-block. The resulting 64-bit output block of each iteration feeds back as the input of the next iteration. To decipher, it is only necessary to apply the same algorithm to the enciphered message block, taking care that each iteration of the computation will use the same 48-bit key which was used during enciphering.

The triple DES is the DES used three times in a row (also known as DES-EDE). It uses three keys key1, key2, and key3, so that key length is 168 bits effective: a 64-bit block plaintext is encrypted with key1, decrypted with key2, and encrypted with key3, and a 64-bit ciphertext is decrypted with key1, encrypted with key2, and decrypted with key3.

There are three keying options defined in ANSI X9.52 for DES-EDE:

- The three keys key1, key2, and key3 are independent.
- key1 and key2 are independent, but key1 = key3
- key1 = key2 = key3

The first option provides highest level of security; the last option is compatible with single DES. See Table 14-1 on page 1016 for key use.

Table 14-1. Key Repartition

Mode	Key1_L	Key1_H	Key2_L	Key2_H	Key3_L	Key3_H
64-bit (DES)	√	√	X	X	X	X
192-bit (3DES)	√	√	√	√	√	√

ECB, CBC, and CFB modes can be used with DES and 3DES modes.

14.2 DES Block Diagram

The module architecture consists of primary blocks, as shown in Figure 14-1 on page 1016. The DES module includes a register interface, and a μ DMA and interrupt interface.

Depending of the availability of context and data, the DES engine is automatically triggered to process the data. The DES engine is directly connected to the context and data registers such that it can immediately start processing when all data is available.

Packets (blocks of 64 bits) must be parsed into blocks and sequentially fed into the DES, which can buffer the block currently being processed as well as an additional block that may be queued in advance.

Figure 14-1. DES Block Diagram

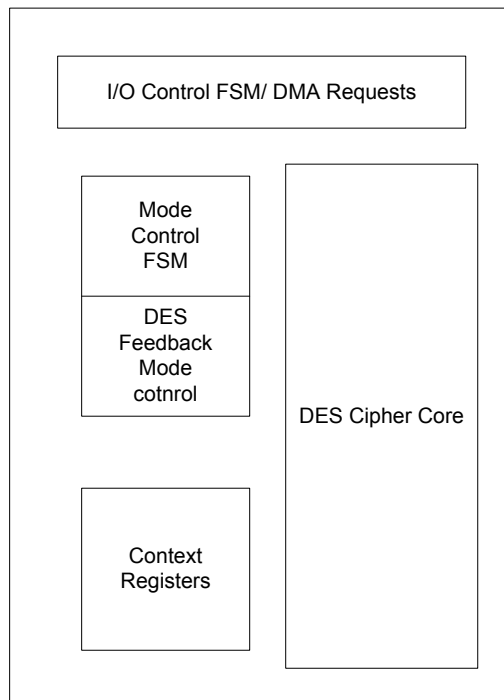

14.2.1 μ DMA Control

The μ DMA and interrupt request logic is controlled by the DES Engine. The DES Engine can have multiple μ DMA request signals active in parallel.

There are three DMA channels available:

- DMA context in - Request a new context (DES0 Cin)
- DMA data in - Request input data (DES0 Din)
- DMA data out - Request output data read (DES0 Dout)

14.2.2 Interrupt Control

There is one interrupt for the DES that is sent to the interrupt controller. This interrupt is an OR of the enabled interrupt bits in the **DES Interrupt Status (DES_IRQSTATUS)** register. These bits are enabled through the **DES Interrupt Enable (DES_IRQENABLE)** register. The following events can generate an interrupt bit to be set in the **DES_IRQSTATUS** register. These are:

- New context input required
- Data input required
- Data output ready

14.2.3 Register Interface

The Register Interface block performs all address decoding and control; however, not all registers are available in this block. The context and data input registers are in the DES engine.

14.2.4 DES Engine

The DES buffered engine consists of the following major functional blocks:

- Cipher core: the DES algorithm
- Mode control FSM: manages the data flow to and from the DES buffered engine and starts each encrypt/decrypt operation
- DES feedback mode block: the logic that implements the various feedback modes supported by the DES buffered engine

14.2.4.1 Mode Control FSM

The Mode control FSM manages the data flow to and from the DES engine. This block also sends a start pulse to the encrypt/decrypt core and triggers the core to use the new mode keys when a new context is needed. This module also controls the 3DES operation, such that the DES core module is triggered three times (with different keys) before the result data becomes available.

14.2.4.2 DES Feedback Mode Block

The DES feedback mode block buffers the input and output blocks and contains all logic to implement the 3DES and various feedback modes. See the FIPS-81 document for details on the ECB, CBC, and CFB modes of operation.

By itself, the DES cipher core outputs data compliant for ECB encryption. However, most applications use DES with feedback. Feedback provides additional security by randomizing repeated patterns in the plain text, which could otherwise be exploited to attack the cipher text. The DES buffered engine supports ECB, CBC, and CFB modes of operations for the DES and 3DES algorithm.

3DES mode performs the DES algorithm three times on a single block and uses a different key for each invocation of the DES algorithm, greatly increasing security of the cipher text but at the cost

of a 3x reduction in throughput. The DES buffered engine implements a 3DES logic wrapper around the 2-round DES core, enabling seamless 3DES encryption.

14.2.4.3 DES Cipher Core

The DES cipher core implements the DES algorithm as specified in the FIPS 46-3. The core operates on the input block and performs the required substitution, shift, and mix operations. The core also applies the correct key-scheduling.

Inherently, considerable parallelism is possible with the DES algorithm. This is exploited in two ways. For high performance, the 64 bits composing the data block are processed concurrently (4-round implementation). For low gate-count, resources are shared on both the main data and key paths (1-round implementation).

A fundamental component of the DES algorithm is the substitution box (S-Box). The S-Box provides a unique 4-bit output for each 6-bit input. The S-Box design is a primary factor for both performance and gate count. The DES Cipher Core has a standard lookup table S-Box that allows room for the synthesizer to optimize on timing or gate count.

14.3 Software Reset

Table 14-2 on page 1018 lists the resets used in the DES module.

Table 14-2. DES Reset Description

Type	Name	Source	Description
Hardware	DES_RST	PRCM	Global reset
Software	DES_SYSCONFIG [1] SOFTRESET	Internal	Starts the soft reset sequence. When the DES_SYSSTATUS/DES_P_SYSSTATUS[0] RESETDONE bit goes to 1, the soft reset sequence is finished.

14.4 DES Supported Modes of Operation

14.4.1 ECB Feedback Mode

Figure 14-2 on page 1019 shows the basic ECB feedback mode of operation, where the input data is passed directly to the basic cryptographic core and the output of the cryptographic core is passed directly to the output buffer. For decryption the DES core operates in reverse, this means the decrypt key sequence is used for the data processing, where encryption uses the encrypt key sequence.

Figure 14-2. DES - ECB Feedback Mode

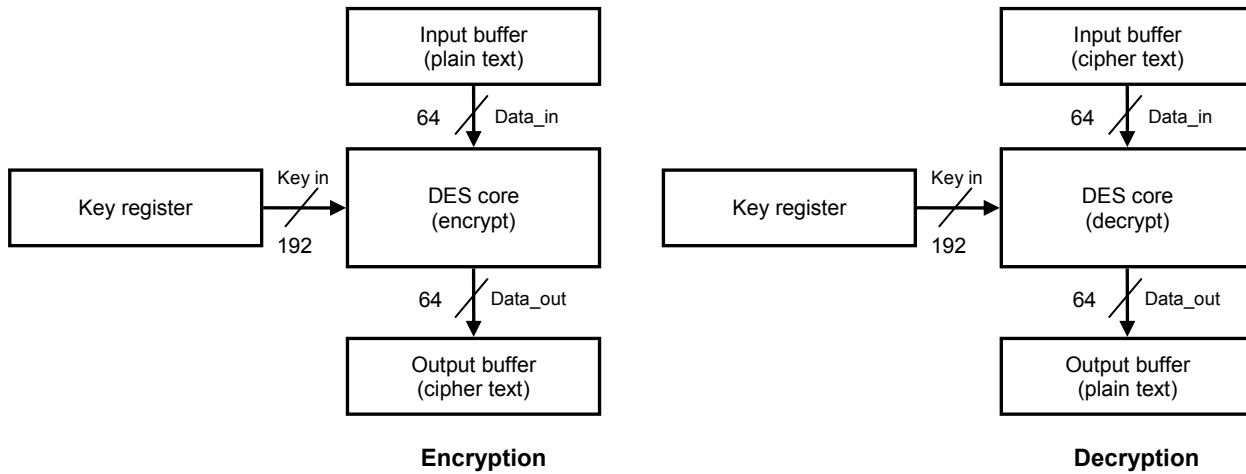

14.4.1.1 CBC Feedback Mode

Figure 14-3 on page 1019 shows the CBC feedback mode of operation, where the input data is XORed with the initialization vector (IV) before it is passed to the basic crypto core. The output of the crypto core is passed directly to the output buffer. For decryption the operation is reversed, resulting in an XOR at the output of the crypto core.

Figure 14-3. DES3DES - CBC Feedback Mode

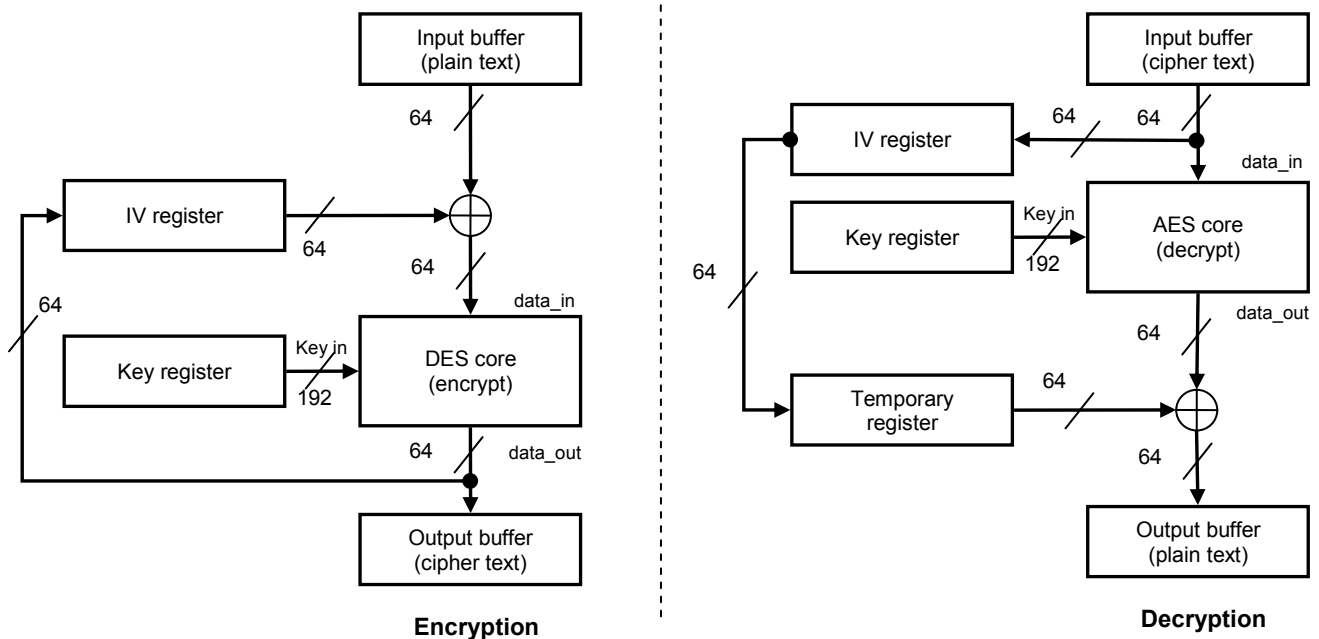

14.4.1.2 CFB Feedback Mode

Figure 14-4 on page 1020 shows the CFB mode of operation for encryption and decryption. The input for the crypto core is the IV; the result is XORed with the data. The result is fed back via the IV register, as the next input for the crypto core. The decrypt operation is reversed, but the crypto core is still performing an encryption.

Figure 14-4. DES3DES-CFB Feedback Mode

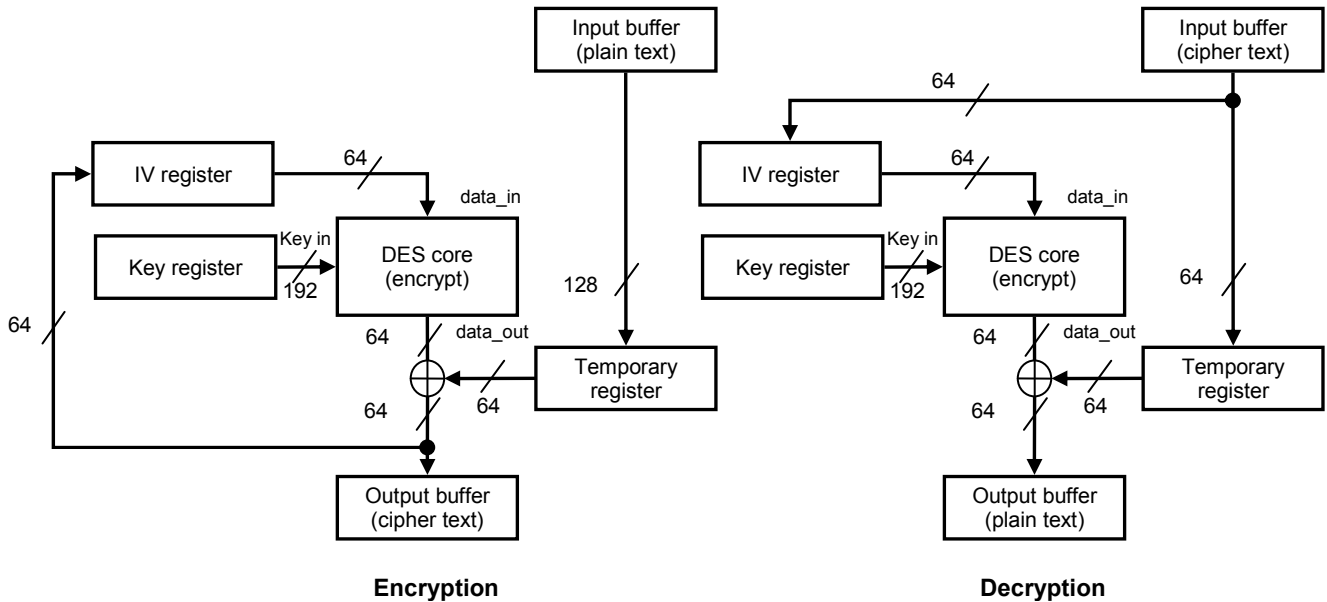

14.5 DES Module Programming Guide -Low Level Programming Models

14.5.1 Surrounding Modules Global Initialization

14.5.1.1 Main Sequence - DES Global Initialization

This procedure initializes the DES after a POR.

Table 14-3. DES Global Initialization

Step	Register/Bit Field/Programming Model	Value
Execute software reset.	DES_SYSCONFIG[1] SOFTRESET	0x1
Wait for reset to complete	DES_SYSSTATUS[0] RESETDONE	= 0x1
Select force idle mode	DES_SYSCONFIG[3:2] SIDLE	0x0
Select the algorithm type (DES or 3DES)	See the programming models	
Select the operating mode (ECB, CBC or CFB).	DES_CTRL[5:4] MODE	-
IF: ECB operating mode not selected.	DES_CTRL[5:4] MODE	≠ 0x0
Load the initialization vector LSW.	DES_IV_L[31:0] IV_L	-
Load the initialization vector MSW.	DES_IV_H[31:0] IV_H	-
Define the cryptographic data length.	DES_LENGTH[31:0] LENGTH	-
ENDIF		
Select encryption or decryption.	DES_CTRL[2] DIRECTION	-

14.5.1.2 Subsequence - Configure the DES Algorithm Type

This subsequence details the DES algorithm type settings.

Table 14-4. DES Algorithm Type Configuration

Step	Register/Bit Field/Programming Model	Value
Load key 1 LSW.	DES_KEY1_L[31:0] KEY1_L	-
Load key 1 MSW.	DES_KEY1_H[31:0] KEY1_H	-
Select DES algorithm.	DES_CTRL[3] TDES	0x0

14.5.1.3 Subsequence - Configure the 3DES Algorithm Type

This subsequence details the 3DES algorithm type settings.

Table 14-5. 3DES Algorithm Type Configuration

Step	Register/Bit Field/Programming Model	Value
Load key 1 LSW.	DES_KEY1_L[31:0] KEY1_L	-
Load key 1 MSW.	DES_KEY1_H[31:0] KEY1_H	-
Load key 2 LSW.	DES_KEY2_L[31:0] KEY2_L	-
Load key 2 MSW.	DES_KEY2_H[31:0] KEY2_H	-
Load key 3 LSW.	DES_KEY3_L[31:0] KEY3_L	-
Load key 3 MSW.	DES_KEY3_H[31:0] KEY3_H	-
Select 3DES algorithm.	DES_CTRL[3] TDES	0x1

14.5.2 Operational Modes Configuration

14.5.2.1 Main Sequence - DES Polling Mode

Figure 14-5 on page 1022 shows DES polling mode. The registers used in DES polling mode are: DES_DATA_L, DES_DATA_H, and DES_CTRL.

Figure 14-5. DES Polling Mode

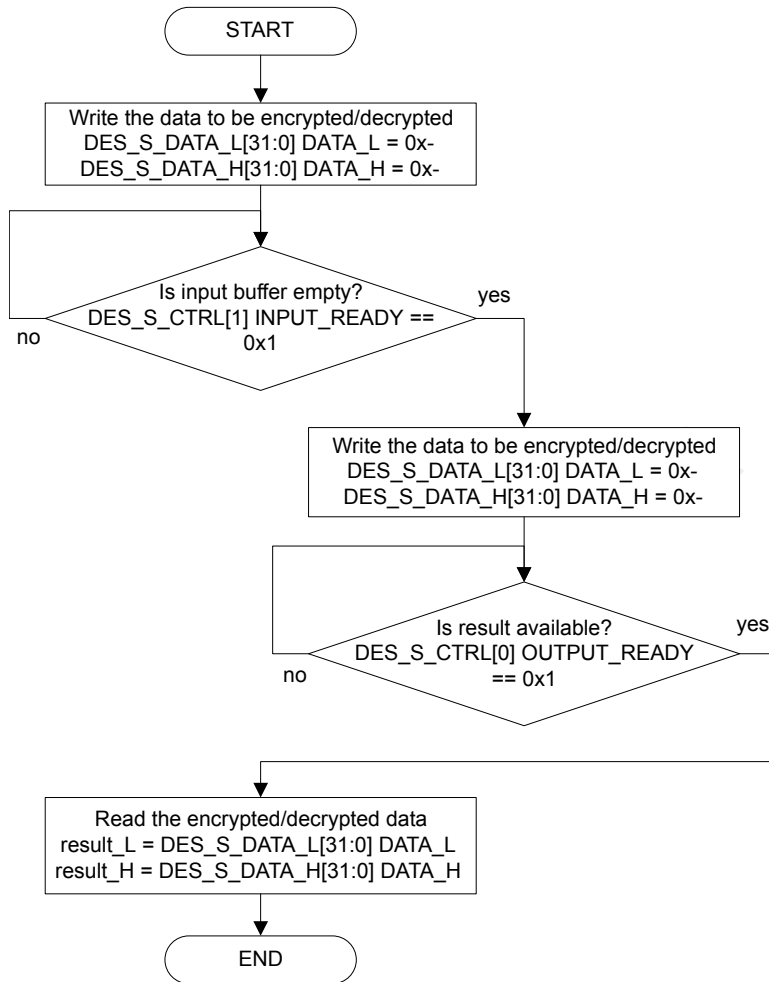

14.5.2.2 DES Interrupt Mode

Table 14-6 on page 1022 lists the DES interrupt mode steps.

Table 14-6. DES Interrupt Mode

Step	Register/Bit Field/Programming Model	Value
Enable DES module interrupts.	DES_IRQENABLE[2:0]	0x7
Load the input buffer data LSW register.	DES_DATA_L[31:0] DATA_L	-
Load the input buffer data HSW register.	DES_DATA_H[31:0] DATA_H	-

14.5.2.3 DES Interrupt DMA Mode

Table 14-7 on page 1022 lists the DES DMA mode steps.

Table 14-7. DES DMA Mode

Step	Register/Bit Field/Programming Model	Value
Enable DES module DMA requests.	DES_SYSCONFIG[7:5]	0x7
Load the input buffer data LSW register.	DES_DATA_L[31:0] DATA_L	-

Table 14-7. DES DMA Mode (continued)

Step	Register/Bit Field/Programming Model	Value
Load the input buffer data HSW register.	DES_DATA_H[31:0] DATA_H	-

14.5.3 DES Events Servicing

14.5.3.1 Interrupt Servicing

This section describes the event servicing of the module. Figure 14-6 on page 1023 shows the DES interrupt service. The registers used during event servicing are: DES_IRQSTATUS, DES_DATA_L, and DES_DATA_H.

Figure 14-6. DES Interrupt Service

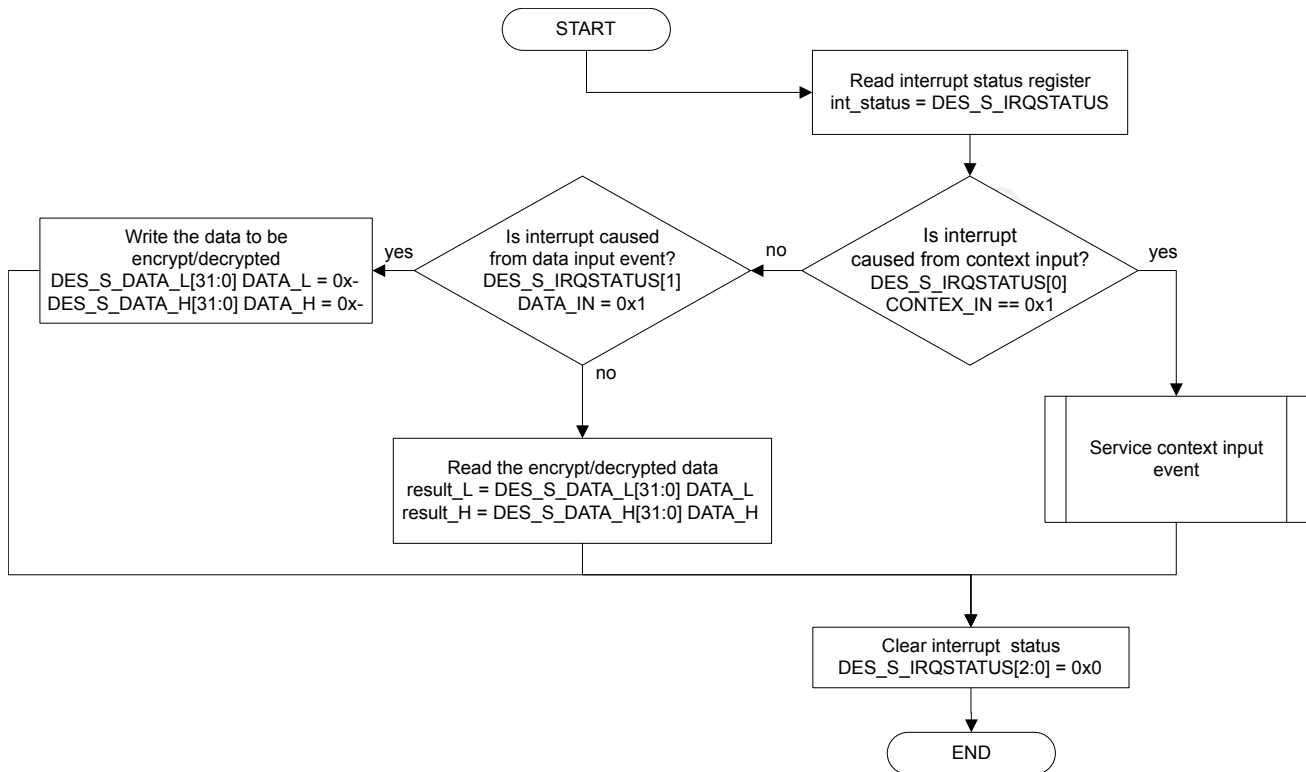

14.5.3.2 Context Input Event Servicing

This section describes the context input event servicing of the module, as shown in Figure 14-7 on page 1024. The registers used during event servicing are: DES_CTRL, DES_SYSCONFIG, DES_KEY1_L, DES_KEY1_H, DES_KEY2_L, DES_KEY2_H, DES_KEY3_L, DES_KEY3_H, DES_IV_L, DES_IV_H, and DES_LENGTH.

Figure 14-7. DES Context Input Event Service

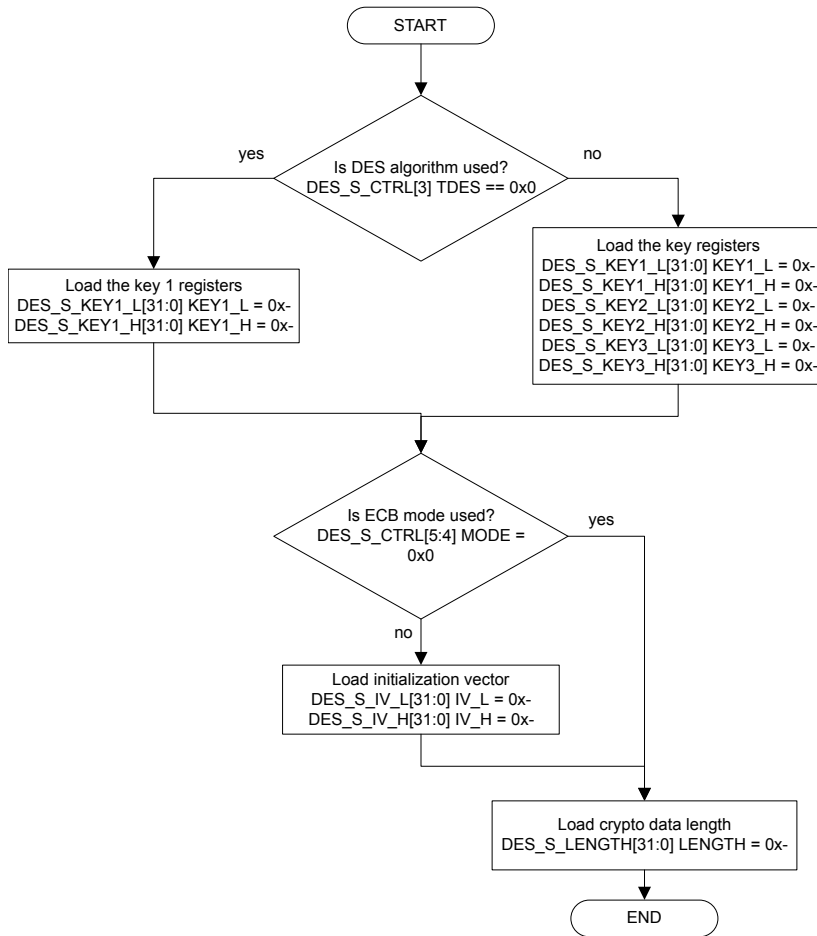

14.6 Register Map

Table 14-8 on page 1024 lists the DES registers. The DES Module comprises registers that exist at an offset relative to the DES Module base address and a small set of DES μ DMA registers that exist at an offset relative to an Encryption Control Module base address. The DES Module register offsets are relative to the base address 0x4403.8000 . The Encryption Control register offsets are relative to the base address 0x4403.0000.

Note: The DES registers are limited to 32-bit data accesses; 8- and 16-bit accesses are not allowed and can corrupt register contents.

Table 14-8. DES Register Map

Offset	Name	Type	Reset	Description	See page
DES Module Registers (DES Module Offset)					
0x000	DES_KEY3_L	RW	0x0000.0000	DES Key 3 LSW for 192-Bit Key	1026
0x004	DES_KEY3_H	RW	0x0000.0000	DES Key 3 MSW for 192-Bit Key	1026
0x008	DES_KEY2_L	RW	0x0000.0000	DES Key 2 LSW for 128-Bit Key	1026

Table 14-8. DES Register Map (continued)

Offset	Name	Type	Reset	Description	See page
0x00C	DES_KEY2_H	RW	0x0000.0000	DES Key 2 MSW for 128-Bit Key	1026
0x010	DES_KEY1_L	RW	0x0000.0000	DES Key 1 LSW for 64-Bit Key	1026
0x014	DES_KEY1_H	RW	0x0000.0000	DES Key 1 MSW for 64-Bit Key	1026
0x018	DES_IV_L	RW	0x0000.0000	DES Initialization Vector	1027
0x01C	DES_IV_H	RW	0x0000.0000	DES Initialization Vector	1028
0x020	DES_CTRL	RW	0x8000.0000	DES Control	1029
0x024	DES_LENGTH	RW	0x0000.0000	DES Cryptographic Data Length	1030
0x028	DES_DATA_L	RW	0x0000.0000	DES LSW Data RW	1031
0x02C	DES_DATA_H	RW	0x0000.0000	DES MSW Data RW	1032
0x030	DES_REVISION	RO	0x0000.0021	DES Revision Number	1033
0x034	DES_SYSCONFIG	RW	0x0000.0001	DES System Configuration	1034
0x038	DES_SYSSTATUS	RO	0x0000.0001	DES System Status	1036
0x03C	DES_IRQSTATUS	RO	0x0000.0000	DES Interrupt Status	1037
0x040	DES_IRQENABLE	RW	0x0000.0000	DES Interrupt Enable	1038
0x044	DES_DIRTYBITS	RW1C	0x0000.0000	DES Dirty Bits	1039
DES μDMA Interrupt Registers (CRC and Cryptographic Modules (CCM) Offset)					
0x030	DES_DMAIM	RW	0x0000.0000	DES DMA Interrupt Mask	1040
0x034	DES_DMARIS	RO	0x0000.0000	DES DMA Raw Interrupt Status	1041
0x038	DES_DMAMIS	RO	0x0000.0000	DES DMA Masked Interrupt Status	1042
0x03C	DES_DMAIC	W1C	0x0000.0000	DES DMA Interrupt Clear	1043

14.7 DES Register Description

This section lists and describes the DES registers, in numerical order by address offset.

- Register 1: DES Key 3 LSW for 192-Bit Key (DES_KEY3_L), offset 0x000**
- Register 2: DES Key 3 MSW for 192-Bit Key (DES_KEY3_H), offset 0x004**
- Register 3: DES Key 2 LSW for 128-Bit Key (DES_KEY2_L), offset 0x008**
- Register 4: DES Key 2 MSW for 128-Bit Key (DES_KEY2_H), offset 0x00C**
- Register 5: DES Key 1 LSW for 64-Bit Key (DES_KEY1_L), offset 0x010**
- Register 6: DES Key 1 MSW for 64-Bit Key (DES_KEY1_H), offset 0x014**

The function of each of these registers is described in more detail in Table 14-9 on page 1026.

Note: A read of this register returns all zeros.

Table 14-9. DES Key Register Mapping

Register Name	Address Offset	Description
DES_KEY3_L	0x00000000	KEY3 (LSW) for 192-bit key
DES_KEY3_H	0x00000004	KEY3 (MSW) for 192-bit key
DES_KEY2_L	0x00000008	KEY2 (LSW) for 192-bit key
DES_KEY2_H	0x0000000C	KEY2 (MSW) for 192-bit key
DES_KEY1_L	0x00000010	KEY1 (LSW) for 64-bit key/192-bit key
DES_KEY1_H	0x00000014	KEY1 (MSW) for 64-bit key/192-bit key

DES Key for 192-Bit Key (DES_KEYn_n)

Base 0x4403.8000
 Offset 0x000
 Type RW, reset 0x0000.0000

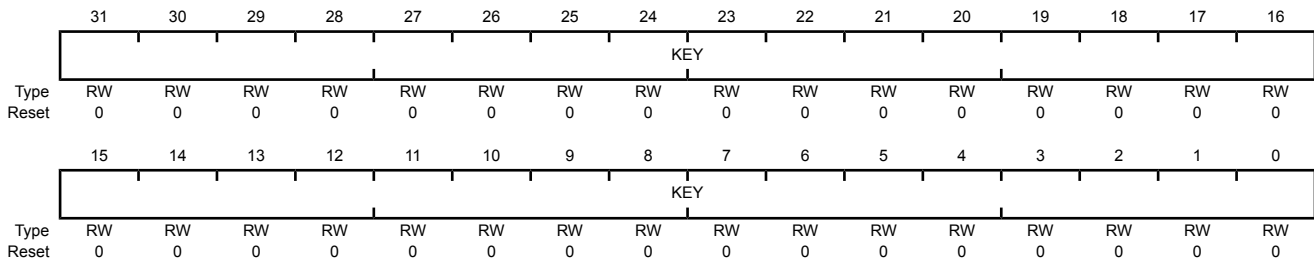

Bit/Field	Name	Type	Reset	Description
31:0	KEY	RW	0x00000000	Key Data

Register 7: DES Initialization Vector (DES_IV_L), offset 0x018

Least significant word of the initialization vector.

DES Initialization Vector (DES_IV_L)

Base 0x4403.8000

Offset 0x018

Type RW, reset 0x0000.0000

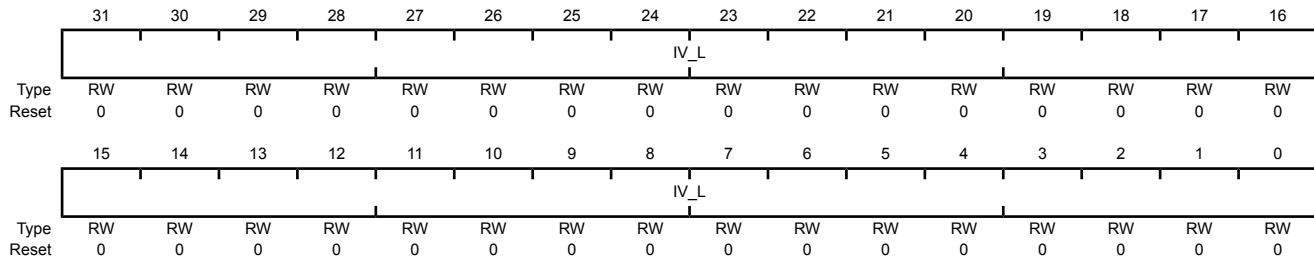

Bit/Field	Name	Type	Reset	Description
31:0	IV_L	RW	0x00000000	Initialization vector for CBC, CFB modes (LSW)

Register 8: DES Initialization Vector (DES_IV_H), offset 0x01C

Most significant word of the initialization vector.

DES Initialization Vector (DES_IV_H)

Base 0x4403.8000
 Offset 0x01C
 Type RW, reset 0x0000.0000

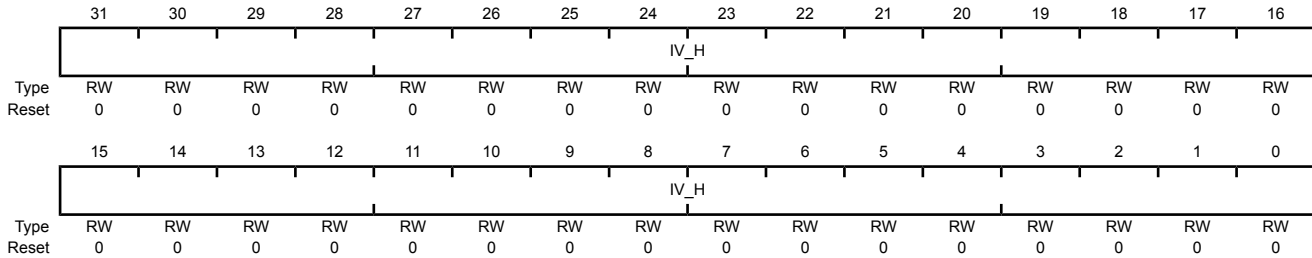

Bit/Field	Name	Type	Reset	Description
31:0	IV_H	RW	0x00000000	Initialization vector for CBC, CFB modes (MSW)

Register 9: DES Control (DES_CTRL), offset 0x020

DES Control (DES_CTRL)

Base 0x4403.8000

Offset 0x020

Type RW, reset 0x8000.0000

	31	30	29	28	27	26	25	24	23	22	21	20	19	18	17	16	
	CONTEXT	reserved															
Type	R	R	R	R	R	R	R	R	R	R	R	R	R	R	R	R	
Reset	1	0	0	0	0	0	0	0	0	0	0	0	0	0	0	0	
	15	14	13	12	11	10	9	8	7	6	5	4	3	2	1	0	
	reserved											MODE		TDES	DIRECTION	INPUT_READY	OUTPUT_READY
Type	R	R	R	R	R	R	R	R	R	R	RW	RW	RW	RW	R	R	
Reset	0	0	0	0	0	0	0	0	0	0	0	0	0	0	0	0	

Bit/Field	Name	Type	Reset	Description
31	CONTEXT	R	1	If 1, this read-only status bit indicates that the context data registers can be overwritten and the host is permitted to write the next context.
30:6	reserved	R	0	Software should not rely on the value of a reserved bit. To provide compatibility with future products, the value of a reserved bit should be preserved across a read-modify-write operation.
5:4	MODE	RW	0	Select CBC, ECB or CFB mode0x0: ECB mode0x1: CBC mode0x2: CFB mode0x3: reserved
3	TDES	RW	0	Select DES or triple DES encryption/decryption.0x0: DES mode0x1:TDESmode
2	DIRECTION	RW	0	Select encryption/decryption 0x0: decryption is selected0x1: Encryption is selected
1	INPUT_READY	R	0	When 1, ready to encrypt/decrypt data
0	OUTPUT_READY	R	0	When 1, Data decrypted/encrypted ready

Register 10: DES Cryptographic Data Length (DES_LENGTH), offset 0x024

Indicates the cryptographic data length in bytes for all modes. Once processing is started with this context, this length decrements to zero. Data lengths up to (232 - 1) bytes are allowed. A write to this register triggers the engine to start using this context.

Note: A read of this register returns all zeros.

DES Cryptographic Data Length (DES_LENGTH)

Base 0x4403.8000
 Offset 0x024
 Type RW, reset 0x0000.0000

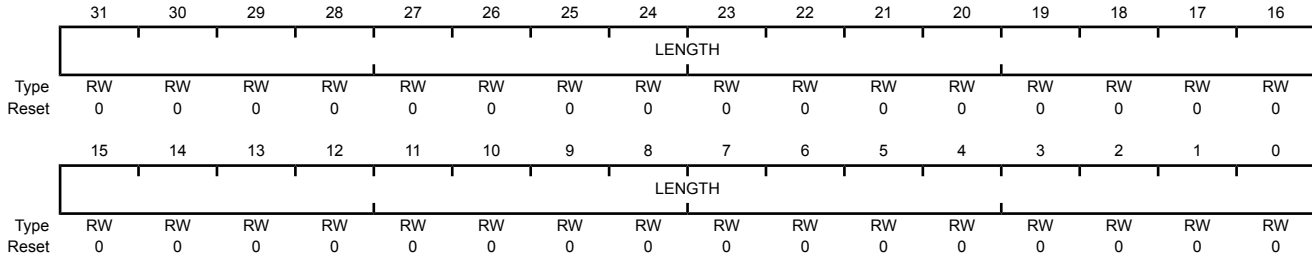

Bit/Field	Name	Type	Reset	Description
31:0	LENGTH	RW	0x00000000	Cryptographic data length in bytes for all modes

Register 11: DES LSW Data RW (DES_DATA_L), offset 0x028

Data register (LSW) to read/write encrypted/decrypted data.

DES LSW Data RW (DES_DATA_L)

Base 0x4403.8000

Offset 0x028

Type RW, reset 0x0000.0000

	31	30	29	28	27	26	25	24	23	22	21	20	19	18	17	16
	DATA_L															
Type	RW	RW	RW	RW	RW	RW	RW	RW	RW	RW	RW	RW	RW	RW	RW	RW
Reset	0	0	0	0	0	0	0	0	0	0	0	0	0	0	0	0
	15	14	13	12	11	10	9	8	7	6	5	4	3	2	1	0
	DATA_L															
Type	RW	RW	RW	RW	RW	RW	RW	RW	RW	RW	RW	RW	RW	RW	RW	RW
Reset	0	0	0	0	0	0	0	0	0	0	0	0	0	0	0	0

Bit/Field	Name	Type	Reset	Description
31:0	DATA_L	RW	0x00000000	Data for encryption/decryption, LSW

Register 12: DES MSW Data RW (DES_DATA_H), offset 0x02C

Data register (MSW) to read/write encrypted/decrypted data.

DES MSW Data RW (DES_DATA_H)

Base 0x4403.8000
 Offset 0x02C
 Type RW, reset 0x0000.0000

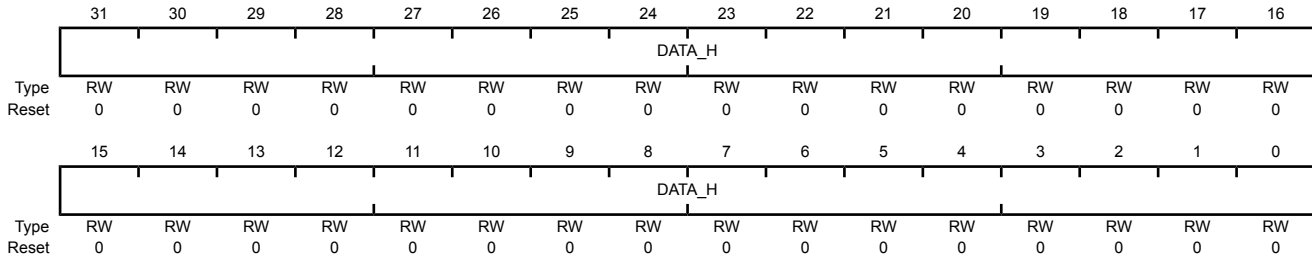

Bit/Field	Name	Type	Reset	Description
31:0	DATA_H	RW	0x00000000	Data for encryption/decryption, MSW

Register 13: DES Revision Number (DES_REVISION), offset 0x030

Revision Number

DES Revision Number (DES_REVISION)

Base 0x4403.8000

Offset 0x030

Type RO, reset 0x0000.0021

	31	30	29	28	27	26	25	24	23	22	21	20	19	18	17	16
	REVISION															
Type	RO	RO	RO	RO	RO	RO	RO	RO	RO	RO	RO	RO	RO	RO	RO	RO
Reset	0	0	0	0	0	0	0	0	0	0	0	0	0	0	0	0
	15	14	13	12	11	10	9	8	7	6	5	4	3	2	1	0
	REVISION															
Type	RO	RO	RO	RO	RO	RO	RO	RO	RO	RO	RO	RO	RO	RO	RO	RO
Reset	0	0	0	0	0	0	0	0	0	0	1	0	0	0	0	1

Bit/Field	Name	Type	Reset	Description
31:0	REVISION	RO	0x0000.0021	Revision number

Register 14: DES System Configuration (DES_SYSCONFIG), offset 0x034

System Configuration of DES module

Note: After one operation has completed, the **DES_SYSCONFIG** register must be cleared and re-configured for the next operation to ensure proper DMA and data operation functionality.

DES System Configuration (DES_SYSCONFIG)

Base 0x4403.8000
Offset 0x034
Type RW, reset 0x0000.0001

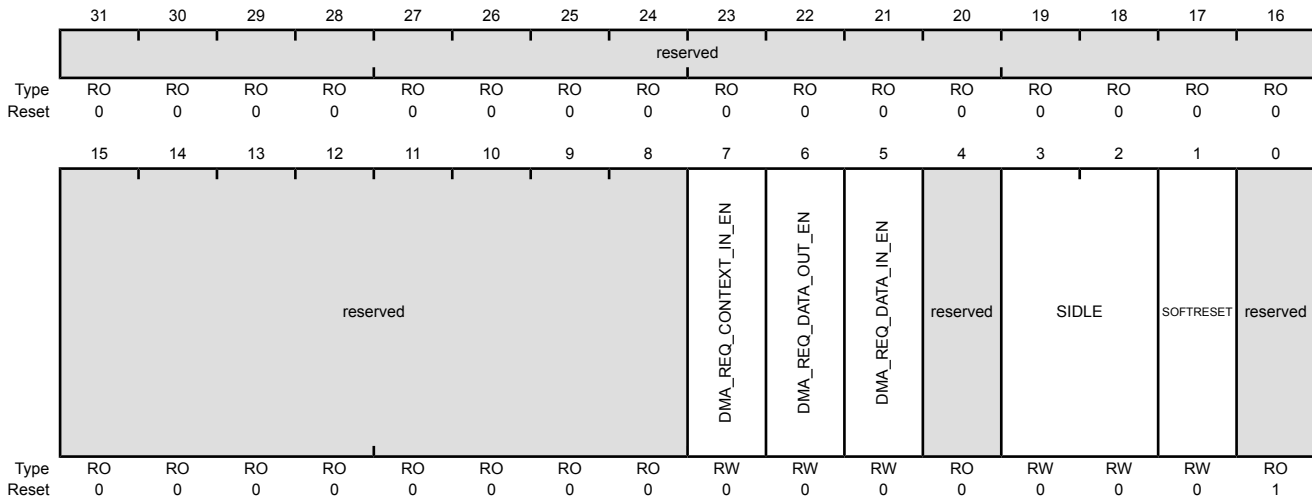

Bit/Field	Name	Type	Reset	Description
31:8	reserved	RO	0	Software should not rely on the value of a reserved bit. To provide compatibility with future products, the value of a reserved bit should be preserved across a read-modify-write operation.
7	DMA_REQ_CONTEXT_IN_EN	RW	0	DMA Request Context In Enable Value Description 0 DMA disabled 1 DMA enabled
6	DMA_REQ_DATA_OUT_EN	RW	0	DMA Request Data Out Enable Value Description 0 DMA disabled 1 DMA enabled
5	DMA_REQ_DATA_IN_EN	RW	0	DMA Request Data In Enable Value Description 0 DMA disabled 1 DMA enabled

Bit/Field	Name	Type	Reset	Description						
4	reserved	RO	0	Software should not rely on the value of a reserved bit. To provide compatibility with future products, the value of a reserved bit should be preserved across a read-modify-write operation.						
3:2	SIDLE	RW	0x0	<p>Sidle mode</p> <table border="1"> <thead> <tr> <th>Value</th> <th>Description</th> </tr> </thead> <tbody> <tr> <td>0x0</td> <td>Force-idle mode</td> </tr> <tr> <td>0x1-0x3</td> <td>reserved</td> </tr> </tbody> </table>	Value	Description	0x0	Force-idle mode	0x1-0x3	reserved
Value	Description									
0x0	Force-idle mode									
0x1-0x3	reserved									
1	SOFTRESET	RW	0	<p>Soft reset</p> <table border="1"> <thead> <tr> <th>Value</th> <th>Description</th> </tr> </thead> <tbody> <tr> <td>0</td> <td>No operation</td> </tr> <tr> <td>1</td> <td>Start soft reset sequence</td> </tr> </tbody> </table>	Value	Description	0	No operation	1	Start soft reset sequence
Value	Description									
0	No operation									
1	Start soft reset sequence									
0	reserved	RO	1	Software should not rely on the value of a reserved bit. To provide compatibility with future products, the value of a reserved bit should be preserved across a read-modify-write operation.						

Register 15: DES System Status (DES_SYSSTATUS), offset 0x038

System Status Register

DES System Status (DES_SYSSTATUS)

Base 0x4403.8000

Offset 0x038

Type RO, reset 0x0000.0001

	31	30	29	28	27	26	25	24	23	22	21	20	19	18	17	16
	reserved															
Type	RO	RO	RO	RO	RO	RO	RO	RO	RO	RO	RO	RO	RO	RO	RO	RO
Reset	0	0	0	0	0	0	0	0	0	0	0	0	0	0	0	0
	15	14	13	12	11	10	9	8	7	6	5	4	3	2	1	0
	reserved															RESETDONE
Type	RO	RO	RO	RO	RO	RO	RO	RO	RO	RO	RO	RO	RO	RO	RO	RO
Reset	0	0	0	0	0	0	0	0	0	0	0	0	0	0	0	1

Bit/Field	Name	Type	Reset	Description
31:1	reserved	RO	0	Software should not rely on the value of a reserved bit. To provide compatibility with future products, the value of a reserved bit should be preserved across a read-modify-write operation.
0	RESETDONE	RO	1	Reset Done
				Value Description
				0 Reset is not complete
				1 Reset done

Register 16: DES Interrupt Status (DES_IRQSTATUS), offset 0x03C

This register indicates the interrupt status. If one of the interrupt bits is set the interrupt output will be asserted.

DES Interrupt Status (DES_IRQSTATUS)

Base 0x4403.8000

Offset 0x03C

Type RO, reset 0x0000.0000

	31	30	29	28	27	26	25	24	23	22	21	20	19	18	17	16
	reserved															
Type	RO	RO	RO	RO	RO	RO	RO	RO	RO	RO	RO	RO	RO	RO	RO	RO
Reset	0	0	0	0	0	0	0	0	0	0	0	0	0	0	0	0
	15	14	13	12	11	10	9	8	7	6	5	4	3	2	1	0
	reserved													DATA_OUT	DATA_IN	CONTEX_IN
Type	RO	RO	RO	RO	RO	RO	RO	RO	RO	RO	RO	RO	RO	RO	RO	RO
Reset	0	0	0	0	0	0	0	0	0	0	0	0	0	0	0	0

Bit/Field	Name	Type	Reset	Description
31:3	reserved	RO	0x0000.0000	Software should not rely on the value of a reserved bit. To provide compatibility with future products, the value of a reserved bit should be preserved across a read-modify-write operation.
2	DATA_OUT	RO	0	This bit indicates data output interrupt is active and triggers the interrupt output.
1	DATA_IN	RO	0	This bit indicates data input interrupt is active and triggers the interrupt output.
0	CONTEX_IN	RO	0	This bit indicates context interrupt is active and triggers the interrupt output.

Register 17: DES Interrupt Enable (DES_IRQENABLE), offset 0x040

This register contains an enable bit for each unique interrupt generated by the module. It matches the layout of **DES_IRQSTATUS** register. An interrupt is enabled when the bit in this register is set to 1.

DES Interrupt Enable (DES_IRQENABLE)

Base 0x4403.8000
 Offset 0x040
 Type RW, reset 0x0000.0000

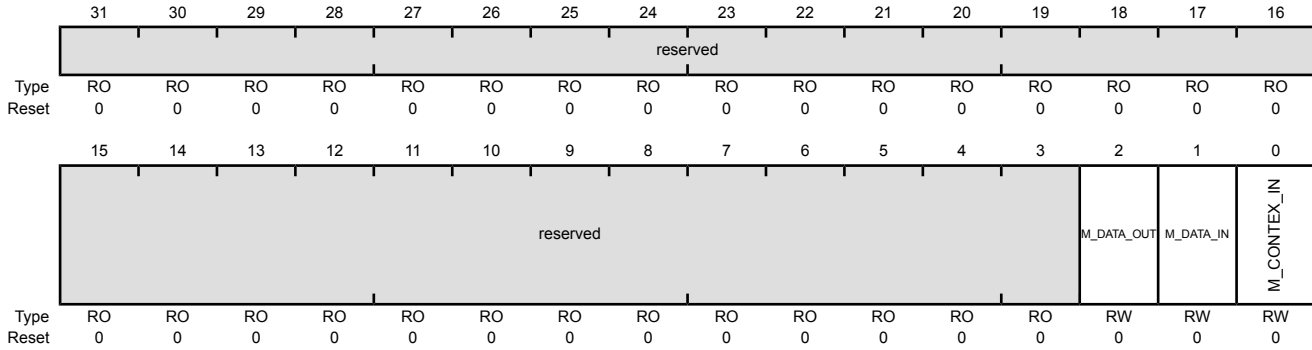

Bit/Field	Name	Type	Reset	Description
31:3	reserved	RO	0x0000.0000	Software should not rely on the value of a reserved bit. To provide compatibility with future products, the value of a reserved bit should be preserved across a read-modify-write operation.
2	M_DATA_OUT	RW	0	If this bit is set to 1 the data output interrupt is enabled.
1	M_DATA_IN	RW	0	If this bit is set to 1 the data input interrupt is enabled.
0	M_CONTEX_IN	RW	0	If this bit is set to 1 the context interrupt is enabled.

Register 18: DES Dirty Bits (DES_DIRTYBITS), offset 0x044

DES Dirty Bits (DES_DIRTYBITS)

Base 0x4403.8000

Offset 0x044

Type RW1C, reset 0x0000.0000

	31	30	29	28	27	26	25	24	23	22	21	20	19	18	17	16
	reserved															
Type	R	R	R	R	R	R	R	R	R	R	R	R	R	R	R	R
Reset	0	0	0	0	0	0	0	0	0	0	0	0	0	0	0	0
	15	14	13	12	11	10	9	8	7	6	5	4	3	2	1	0
	reserved														S_DIRTY	S_ACCESS
Type	R	R	R	R	R	R	R	R	R	R	R	R	R	R	RW1C	RW1C
Reset	0	0	0	0	0	0	0	0	0	0	0	0	0	0	0	0

Bit/Field	Name	Type	Reset	Description
31:2	reserved	R	0	Software should not rely on the value of a reserved bit. To provide compatibility with future products, the value of a reserved bit should be preserved across a read-modify-write operation.
1	S_DIRTY	RW1C	0	This bit is set to 1 by the module if any of the DES_* registers is written. Except DES_DIRTYBITS and DES_LOCKDOWN.
0	S_ACCESS	RW1C	0	This bit is set to 1 by the module if any of the DES_* registers is read. Except DES_DIRTYBITS and DES_LOCKDOWN.

14.8 DES μ DMA Interrupt Register Descriptions (CCM Offset)

This section lists and describes the DES μ DMA registers, in numerical order by address offset. Registers in this section are relative to the base address of 0x4403.0000.

Register 19: DES DMA Interrupt Mask (DES_DMAIM), offset 0x030

The **DES DMA Interrupt Mask** register control interrupt behavior and are used to program which interrupts are suppressed.

DES DMA Interrupt Mask (DES_DMAIM)

Base 0x4403.0000
 Offset 0x030
 Type RW, reset 0x0000.0000

	31	30	29	28	27	26	25	24	23	22	21	20	19	18	17	16	
	reserved																
Type	RO	RO	RO	RO	RO	RO	RO	RO	RO	RO	RO	RO	RO	RO	RO	RO	
Reset	0	0	0	0	0	0	0	0	0	0	0	0	0	0	0	0	
	15	14	13	12	11	10	9	8	7	6	5	4	3	2	1	0	
	reserved													DOUT	DIN	CIN	
Type	RO	RO	RO	RO	RO	RO	RO	RO	RO	RO	RO	RO	RO	RO	RW	RW	RW
Reset	0	0	0	0	0	0	0	0	0	0	0	0	0	0	0	0	0

Bit/Field	Name	Type	Reset	Description				
31:3	reserved	RO	0x0000.000	Software should not rely on the value of a reserved bit. To provide compatibility with future products, the value of a reserved bit should be preserved across a read-modify-write operation.				
2	DOUT	RW	0	<p>Data Out DMA Done Interrupt Mask</p> <p>If this bit is unmasked, an interrupt is generated when the μDMA writes the last word of the process result.</p> <p>Value Description</p> <table border="0"> <tr> <td>0</td> <td>The <code>DOUT</code> interrupt is suppressed and not sent to the interrupt controller.</td> </tr> <tr> <td>1</td> <td>The <code>DOUT</code> interrupt is sent to the interrupt controller.</td> </tr> </table>	0	The <code>DOUT</code> interrupt is suppressed and not sent to the interrupt controller.	1	The <code>DOUT</code> interrupt is sent to the interrupt controller.
0	The <code>DOUT</code> interrupt is suppressed and not sent to the interrupt controller.							
1	The <code>DOUT</code> interrupt is sent to the interrupt controller.							
1	DIN	RW	0	<p>Data In DMA Done Interrupt Mask</p> <p>If this bit is unmasked, an interrupt is generated when the μDMA writes the last word of input data to the internal FIFO of the engine.</p> <p>Value Description</p> <table border="0"> <tr> <td>0</td> <td>The <code>DIN</code> interrupt is suppressed and not sent to the interrupt controller.</td> </tr> <tr> <td>1</td> <td>The <code>DIN</code> interrupt is sent to the interrupt controller.</td> </tr> </table>	0	The <code>DIN</code> interrupt is suppressed and not sent to the interrupt controller.	1	The <code>DIN</code> interrupt is sent to the interrupt controller.
0	The <code>DIN</code> interrupt is suppressed and not sent to the interrupt controller.							
1	The <code>DIN</code> interrupt is sent to the interrupt controller.							
0	CIN	RW	0	<p>Context In DMA Done Interrupt Mask</p> <p>If this bit is unmasked, an interrupt is generated when the μDMA completes a context write to the internal register.</p> <p>Value Description</p> <table border="0"> <tr> <td>0</td> <td>The <code>CIN</code> interrupt is suppressed and not sent to the interrupt controller.</td> </tr> <tr> <td>1</td> <td>The <code>CIN</code> interrupt is sent to the interrupt controller.</td> </tr> </table>	0	The <code>CIN</code> interrupt is suppressed and not sent to the interrupt controller.	1	The <code>CIN</code> interrupt is sent to the interrupt controller.
0	The <code>CIN</code> interrupt is suppressed and not sent to the interrupt controller.							
1	The <code>CIN</code> interrupt is sent to the interrupt controller.							

Register 20: DES DMA Raw Interrupt Status (DES_DMARIS), offset 0x034

The **DES DMA Raw Interrupt Status** register contains the raw interrupt status. If any of these bits read 1, the processor is interrupted if the corresponding masked interrupt status bit is set to 1.

DES DMA Raw Interrupt Status (DES_DMARIS)

Base 0x4403.0000

Offset 0x034

Type RO, reset 0x0000.0000

	31	30	29	28	27	26	25	24	23	22	21	20	19	18	17	16	
	reserved																
Type	RO	RO	RO	RO	RO	RO	RO	RO	RO	RO	RO	RO	RO	RO	RO	RO	
Reset	0	0	0	0	0	0	0	0	0	0	0	0	0	0	0	0	
	15	14	13	12	11	10	9	8	7	6	5	4	3	2	1	0	
	reserved													DOUT	DIN	CIN	
Type	RO	RO	RO	RO	RO	RO	RO	RO	RO	RO	RO	RO	RO	RO	RW	RW	RW
Reset	0	0	0	0	0	0	0	0	0	0	0	0	0	0	0	0	0

Bit/Field	Name	Type	Reset	Description
31:3	reserved	RO	0x0000.000	Software should not rely on the value of a reserved bit. To provide compatibility with future products, the value of a reserved bit should be preserved across a read-modify-write operation.
2	DOUT	RW	0	Data Out DMA Done Raw Interrupt Status Value Description 0 No Interrupt. 1 The μ DMA has written the last word of the process result and an interrupt has been triggered and is pending.
1	DIN	RW	0	Data In DMA Done Raw Interrupt Status Value Description 0 No Interrupt. 1 The μ DMA has written the last word of input data to the internal FIFO of the engine and an interrupt has been triggered and is pending.
0	CIN	RW	0	Context In DMA Done Raw Interrupt Status Value Description 0 No interrupt. 1 The μ DMA has completed a context write to the internal register and an interrupt has been triggered and is pending.

Register 21: DES DMA Masked Interrupt Status (DES_DMAMIS), offset 0x038

The **DES DMA Masked Interrupt Status** register displays the raw interrupts that are unmasked in the **DES DMA Raw Interrupt Status (DES_DMARIS)** register.

DES DMA Masked Interrupt Status (DES_DMAMIS)

Base 0x4403.0000
 Offset 0x038
 Type RO, reset 0x0000.0000

	31	30	29	28	27	26	25	24	23	22	21	20	19	18	17	16
	reserved															
Type	RO	RO	RO	RO	RO	RO	RO	RO	RO	RO	RO	RO	RO	RO	RO	RO
Reset	0	0	0	0	0	0	0	0	0	0	0	0	0	0	0	0
	15	14	13	12	11	10	9	8	7	6	5	4	3	2	1	0
	reserved													DOUT	DIN	CIN
Type	RO	RO	RO	RO	RO	RO	RO	RO	RO	RO	RO	RO	RO	RO	RO	RO
Reset	0	0	0	0	0	0	0	0	0	0	0	0	0	0	0	0

Bit/Field	Name	Type	Reset	Description
31:3	reserved	RO	0x0000.000	Software should not rely on the value of a reserved bit. To provide compatibility with future products, the value of a reserved bit should be preserved across a read-modify-write operation.
2	DOUT	RO	0	Data Out DMA Done Masked Interrupt Status Value Description 0 An interrupt has not occurred or is masked. 1 A DOUT interrupt has occurred.
1	DIN	RO	0	Data In DMA Done Masked Interrupt Status Value Description 0 An interrupt has not occurred or is masked. 1 A DIN interrupt has occurred.
0	CIN	RO	0	Context In DMA Done Raw Interrupt Status Value Description 0 An interrupt has not occurred or is masked. 1 A CIN interrupt has occurred.

Register 22: DES DMA Interrupt Clear (DES_DMAIC), offset 0x03C

The **DES DMA Interrupt Clear** register is used to clear the **DES_DMARIS** and **DES_DMAMIS** registers by writing a 1 to the corresponding register bit.

Note: This registers always reads as zero.

DES DMA Interrupt Clear (DES_DMAIC)

Base 0x4403.0000

Offset 0x03C

Type W1C, reset 0x0000.0000

	31	30	29	28	27	26	25	24	23	22	21	20	19	18	17	16	
	reserved																
Type	RO	RO	RO	RO	RO	RO	RO	RO	RO	RO	RO	RO	RO	RO	RO	RO	
Reset	0	0	0	0	0	0	0	0	0	0	0	0	0	0	0	0	
	15	14	13	12	11	10	9	8	7	6	5	4	3	2	1	0	
	reserved													DOUT	DIN	CIN	
Type	RO	RO	RO	RO	RO	RO	RO	RO	RO	RO	RO	RO	RO	RO	W1C	W1C	W1C
Reset	0	0	0	0	0	0	0	0	0	0	0	0	0	0	0	0	0

Bit/Field	Name	Type	Reset	Description
31:3	reserved	RO	0x0000.000	Software should not rely on the value of a reserved bit. To provide compatibility with future products, the value of a reserved bit should be preserved across a read-modify-write operation.
2	DOUT	W1C	0	Data Out DMA Done Interrupt Clear Writing a 1 to this bit clears the DOUT bit in the DES_DMARIS and DES_DMAMIS register.
1	DIN	W1C	0	Data In DMA Done Interrupt Clear Writing a 1 to this bit clears the DIN bit in the DES_DMARIS and DES_DMAMIS register.
0	CIN	W1C	0	Context In DMA Done Raw Interrupt Status Writing a 1 to this bit clears the CIN bit in the DES_DMARIS and DES_DMAMIS register.

15 SHA/MD5 Accelerator

The SHA/MD5 module provides hardware-accelerated hash functions and can run:

- MD5 message digest algorithm developed by Ron Rivest in 1991
- SHA-1 algorithm compliant with the [FIPS 180-3 standard](#)
- SHA-2 (SHA-224 and SHA-256) algorithm compliant with the FIPS 180-3 standard
- Hash message authentication code (HMAC) operation

The algorithms produce a condensed representation of a message or a data file, called digest or signature, which can then be used to verify the message integrity.

- Hashing of 0 to $2^{33} - 2$ bytes of data (of which $2^{32} - 1$ bytes are in one pass) using the MD5, SHA-1, SHA-224, or SHA-256 hash algorithm (byte granularity only, no support for bit granularity)
- Automatic HMAC key preprocessing for HMAC keys up to 64 bytes
- Host-assisted HMAC key preprocessing for HMAC keys larger than 64 bytes
- HMAC from precomputes (inner/outer digest) for improved performance on small blocks
- Supports μ DMA operation for data and context in/result out transfers
- Supports interrupt to read the digest (signature)

15.1 SHA/MD5 Functional Description

15.1.1 SHA/MD5 Block Diagram

Figure 15-1 on page 1045 shows the module architecture, which consists of four primary blocks: the Hash/HMAC engine, the configuration registers and the interface to μ DMA and the interrupt handler.

Figure 15-1. SHA/MD5 Module Block Diagram

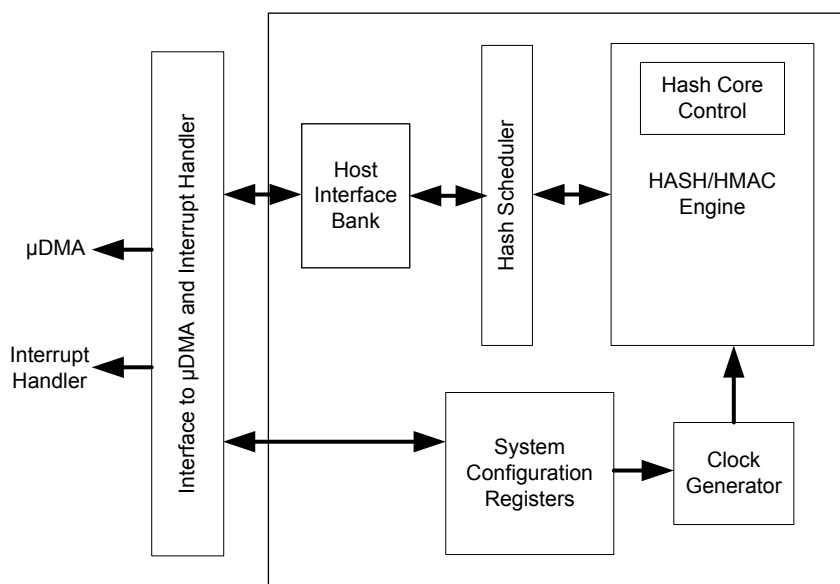

15.1.1.1 Configuration Registers

The configuration registers contain the following global control and status registers for the SHA/MD5 Module:

- System control register that controls the mode of operation (**SHA_SYSCONFIG** register)
- μ DMA interrupt control registers (**SHA_DMAIM**, **SHA_DMARIS**, **SHA_DMAMIS**, and **SHA_DMAIC** registers, which reside in the Encryption Control Base address space)
- Interrupt status register (**SHA_IRQSTATUS** register)
- Enable register (**SHA_IRQENABLE** register)

15.1.1.2 Hash/HMAC Engine

The Hash/HMAC engine performs the SHA-1, SHA-2, or MD5 hash computation. When loaded with a data block, and optionally an intermediate digest, it independently performs the hash computation (64 or 80 rounds, depending on the algorithm) on that data block.

It can also start from the specified initial digest values instead of a loaded intermediate. Furthermore, it can perform the IPAD and OPAD XORs for MAC operations. The hash core does not perform any hash padding; this is performed in the Host Interface Block, where the data input registers are located. A loaded data block must always be a full 64 bytes (512 bits) long.

15.1.1.3 Hash Core Control

When the hash core is idle or done, a new hash operation can be started. Any additional information needed by the hash core (mode of operation, data to process, input digest if not starting from algorithm constants or continuing) must be provided by programming the SHA registers before the core can accept the operation.

15.1.1.4 Host Interface Bank

The Host Interface Bank can access the hash core for hashing individual 64-byte hash blocks. The Host Interface Bank contains registers such as the data FIFO (**SHA Data n Input (SHA_DATA_n_IN)** registers), the **SHA Inner Digest x (SHA_IDIGEST_X)** registers, and several control and status registers.

The Host Interface Block contains all relevant control logic for performing hash and HMAC computations on large (that is, larger than one hash block) blocks of data, including hash padding, final hash, and outer hash. It provides the necessary flow control to the SHA μ DMA and interrupt interface.

15.1.2 Power Management

To save power, the application can disable the clock to the SHA/MD5 module when not in use. The SHA/MD5 is clock gated by setting the `SHACFG` bit in the **Cryptographic Modules Clock Gating Request (CCMCGREQ)** register, CCM offset 0x204. The SHA in addition to the AES, DES, and Enhanced CRC can also be clock gated as a group by setting the `D0` bit in the **CRC and Cryptographic Modules Deep-Sleep Mode Clock Gating Control (DCGCCM)** register, System Control Module offset 0x874.

15.1.3 Reset Management

To perform a software reset of the SHA module, write a 1 to the `SOFTRESET` bit in the **SHA System Configuration (SHA_SYSCONFIG)** register. The `RESETDONE` bit in the **SHA System Status (SHA_SYSSTATUS)** register indicates that the software reset is complete when its value is 1. When the software reset completes, the `SOFTRESET` bit in the **SHA_SYSCONFIG** register is automatically reset. Software must ensure that the software reset completes before doing any operations.

The behavior of the software reset is the same as the hardware reset, except that the software reset bit resets this module without affecting the reset core domain of the entire device.

15.1.4 μ DMA and Interrupt Requests

The SHA/MD5 module can operate in μ DMA mode where the module can assert a μ DMA request for context in, context out, or data input. The μ DMA signals that can be generated are:

- Context In μ DMA request (SHA/MD5 0 Cin): Request for Key, Digest, Mode and LENGTH information
- Context Out μ DMA request (SHA/MD5 0 Cout): Request for read from HMAC
- Data In μ DMA request (SHA/MD5 0 Din): Request input data in multiples of 16 bytes

The SHA/MD5 Module be programmed to assert an interrupt when the μ DMA has completed its last transfer by programming the **SHA DMA Interrupt Mask (SHA_DMAIM)**, at the CRC and Cryptographic Modules (CCM) offset 0x010. The **SHA DMA Raw Interrupt Status (SHA_DMARIS)** register, at CCM offset 0x014, indicates when the μ DMA has completed and can be cleared by the **SHA DMA Interrupt Clear (SHA_DMAIC)** register at CCM offset 0x01C.

Note: The SHA module can only be accessed through privileged mode. If the μ DMA is used for SHA transfers, then the μ DMA's **DMA Channel Control (DMACHCTL)** register also needs to be programmed to allow for privileged accesses.

If context and data transfers are to be handled through software in Interrupt Mode, then the **SHA Interrupt Enable (SHA_IRQENABLE)**, offset 0x11C, can be used to enable interrupt triggering

when context out, context in, data in or data out is ready. The **SHA Interrupt Status (SHA_IRQSTATUS)**, offset 0x118, indicates when an interrupt is triggered.

Note: If the application uses Interrupt Mode, an interrupt is generated for each block of processed data. To support larger data flow, SHA μ DMA Mode should be used and the bits in the **SHA_IRQENABLE** register should be cleared.

Table 15-1. Interrupts and Events

Event	Description
SHA_IRQSTATUS[3]: CONTEXT_OUT	Context output interrupt
SHA_IRQSTATUS[1]: DATA_IN	Data input interrupt
SHA_IRQSTATUS[0]: CONTEXT_IN	Context input interrupt

15.1.5 Operation Description

The SHA/MD5 Module can run the SHA-1, SHA-224, SHA-256, and MD5 algorithms, depending on the value of the **ALGO** bit field in the **SHA Mode (SHA_MODE)** register, offset 0x044, as listed in Table 15-2 on page 1047.

Table 15-2. SHA/MD5 Module Algorithm Selection

ALGO Field Value in SHA_MODE Register	Description
0x0	MD5 algorithm selected
0x1	SHA-1 algorithm selected
0x2	SHA-224 algorithm selected
0x3	SHA-256 algorithm selected

15.1.5.1 SHA Mode

Starting a New Hash

To start a new hash, follow these steps:

1. Set the **ALGO** bitfield in the **SHA_MODE** register, at offset 0x044, to 0x1, 0x2, or 0x3 to select SHA-1, SHA-224, or SHA-256, respectively.
2. Set the **ALGO_CONSTANT** bit in the **SHA_MODE** register to 1 to initialize all **SHA Inner/Outer Digest n** registers from **SHA_ODIGEST_A/SHA_IDIGEST_A** to **SHA_ODIGEST_H/SHA_IDIGEST_H** with their default values specified by the algorithm, and set the **SHA_DIGESTCOUNT** register to 0.
3. Set the **CLOSE_HASH** bit of the **SHA Mode (SHA_MODE)** register to let the SHA engine do the padding. If the Hash is computed in one shot, the length of the message can be any value up to 128 MB. To process an intermediate Hash digest, the **CLOSE_HASH** bit is set to 0, in which case the packets hashed must be 64 bytes; the last packet must be hashed with the **CLOSE_HASH** bit set to 1.
4. Specify the **LENGTH** field in the **SHA Length (SHA_LENGTH)** register of the hash data to process in bytes.

After the configuration is complete, the **INPUT_READY** status bit equals 1 in the **SHA Interrupt Status (SHA_IRQSTATUS)** register (regardless of whether or not the **M_INPUT_READY** bit in the **SHA_IRQENABLE** register is set. When this bit is set, it indicates the SHA engine can receive the

data to process. Data must be written to the 16 x 32-bit **SHA_DATA_n_IN** registers that provide storage for one 64-byte block of data. Unless the `CLOSE_HASH` bit is set, all of the **SHA_DATA_n_IN** input buffers must be filled. Data can be written by single write accesses to the 16 registers from a processor or by a DMA transfer.

For μ DMA transfers, the `DMA_EN` bit must be set in the **SHA_SYSCONFIG** register and the appropriate mask bits must be set in the **SHA_DMAIM** register before starting the new hash. Note that if the μ DMA is used for transfers, the **SHA_IRQENABLE** register should be clear so all interrupts are generated through the μ DMA interrupt registers.

The μ DMA must be configured to transfer 16 data words of 32 bits each time it is triggered by a μ DMA request from the SHA/MD5 Module. The 16 data words written are sent to the 16 **SHA_DATA_n_IN** registers.

The module detects that a 64-byte block is available, and then moves the data to a working register space for processing and asserts the `INPUT_READY` bit in the **SHA_IRQSTATUS** register to 1. If the `DMA_EN` bit in the **SHA_SYSCONFIG** register has been set to 1, a new μ DMA request triggers a new block transfer; otherwise, the processor polls the `INPUT_READY` bit and writes the 16 data words of 32 bits when it equals 1.

This operation is repeated until the length of the message to hash is reached. The `OUTPUT_READY` bit in the **SHA_IRQSTATUS** register then indicates that the hash operation is complete. If the `IT_EN` bit in the **SHA_SYSCONFIG** register is set, an interrupt (active low) is also generated to indicate the hash completion.

The processor can then read the eight digest registers A through H that contain the hash and/or HMAC result. If the hash is an intermediate result of a larger hash, the digest count register must also be read and saved.

Note: The number of digest registers used depends on the algorithm selected for the SHA/MD5 Module (MD5, SHA-1, SHA-224, or SHA-256), as shown in Table 15-3 on page 1048 and Table 15-4 on page 1049

Table 15-3. Outer Digest Registers

Register	Address	MD5 (Read/Write)	SHA-1 (Read/Write)	SHA-2 (Read/Write)	HMAC Key Processing (write)
SHA_ODIGEST_A	0x000	Outer digest [127:96]	Outer digest [159:128]	Outer digest [255:224]	HMAC Key [31:0]
SHA_ODIGEST_B	0x004	Outer digest [95:64]	Outer digest [127:96]	Outer digest [223:192]	HMAC key [63:32]
SHA_ODIGEST_C	0x008	Outer digest [63:32]	Outer digest [95:64]	Outer digest [191:160]	HMAC key [95:64]
SHA_ODIGEST_D	0x00C	Outer digest [31:0]	Outer digest [63:32]	Outer digest [159:128]	HMAC key [127:96]
SHA_ODIGEST_E	0x010		Outer digest [31:0]	Outer digest [127:96]	HMAC key [159:128]
SHA_ODIGEST_F	0x014			Outer digest [95:64]	HMAC key [191:160]
SHA_ODIGEST_G	0x018			Outer digest [63:32]	HMAC key [223:192]
SHA_ODIGEST_H	0x01C			Outer digest [31:0]	HMAC key [255:224]

Table 15-4. Inner Digest Registers

Register	Address	MD5 (Read/Write)	SHA-1 (Read/Write)	SHA-2 (Read/Write)	SHA-256 (Read/Write)	HMAC Key Processing (write)
SHA_IDIGEST_A	0x020	Inner digest [127:96]	Inner digest [159:128]	Inner digest [223:192]	Inner digest [255:224]	HMAC key [287:256]
SHA_IDIGEST_B	0x024	Inner digest [95:64]	Inner digest [127:96]	Inner digest [191:160]	Inner digest [223:192]	HMAC key [319:288]
SHA_IDIGEST_C	0x028	Inner digest [63:32]	Inner digest [95:64]	Inner digest [159:128]	Inner digest [191:160]	HMAC key [351:320]
SHA_IDIGEST_D	0x02C	Inner digest [31:0]	Inner digest [63:32]	Inner digest [127:96]	Inner digest [159:128]	HMAC key [383:352]
SHA_IDIGEST_E	0x030		Inner digest[31:0]	Inner digest [95:64]	Inner digest [127:96]	HMAC key [415:384]
SHA_IDIGEST_F	0x034			Inner digest [63:32]	Inner digest [95:64]	HMAC key [447:416]
SHA_IDIGEST_G	0x038			Inner digest [31:0]	Inner digest [63:32]	HMAC key [479:448]
SHA_IDIGEST_H	0x03C				Inner digest[31:0]	HMAC key [511:480]

Note: Inner digests are initial, intermediate, and result digests.

Outer Digest Registers

The **SHA_ODIGEST_A** to **SHA_ODIGEST_H** registers are relevant only for HMAC operations; the contents are ignored for hash operations.

Before writing to the digest registers, the operation must be configured in the **SHA Mode (SHA_MODE)** register. For HMAC operations without key processing, the **HMAC_KEY_PROC** bit must be clear in the **SHA_MODE** register before starting operations. Once the algorithm has been programmed in the **SHA_MODE** register, only the relevant digest registers for the selected algorithm must be written:

- **SHA_ODIGEST_A** to **SHA_ODIGEST_D** registers for MD5
- **SHA_ODIGEST_A** to **SHA_ODIGEST_E** registers for SHA-1
- **SHA_ODIGEST_A** to **SHA_ODIGEST_H** registers for SHA-2 (224 to 256)

When HMAC key processing is enabled (**HMAC_KEY_PROC**=1), these registers must be written with the lower 256 bits of the HMAC key to be processed in little-endian format (first byte of key string in bits [7:0]).

Note: If the HMAC key is less than 512 bits, it must be properly padded with zeros: all 16 HMAC key registers must be written explicitly; the core does not pad. Additionally, if the HMAC key is larger than 512 bits, the host must perform a preprocessing step to reduce it to one 512-bit block. This involves hashing the large key and padding the hash result with zeros until it is 512 bits wide.

The computed outer digest can be read from these registers when the **SHA Interrupt Status (SHA_IRQSTATUS)** register when the **OUTPUT_READY** bit has been set indicating that the operation is done.

Note: If no HMAC key processing is performed, the value read is identical to the value written initially. The MD5 outer digest is available from registers **SHA_ODIGEST_A** to

SHA_ODIGEST_D, the SHA-1 outer digest from registers **SHA_ODIGEST_A** to **SHA_ODIGEST_E**, and the SHA-224 and SHA-256 outer digest from registers **SHA_ODIGEST_A** to **SHA_ODIGEST_H**.

Note: The HMAC key is not preserved. If another block must be authenticated using the same key, the key must be reloaded by the host. If the same key must be used many times, it is advisable to do a HMAC key processing-only pass to obtain the inner and outer digest precomputes and load these precomputes for subsequent passes (only the inner digest must be reloaded if the outer digest is not modified by the host), because this saves two hash blocks worth of computation time.

Inner Digest Registers

The **SHA_IDIGEST_A** to **SHA_IDIGEST_H** registers are used for HMAC and hash operations.

The inner/initial digest for HMAC and hash continue operations (**HMAC_KEY_PROC** = 0 and **ALGO_CONSTANT** = 0) must be written to these registers before starting the operation by writing to the **SHA_MODE** register. Only the relevant digest registers for the selected algorithm must be written:

- **SHA_IDIGEST_A** to **SHA_IDIGEST_D** registers for MD5
- **SHA_IDIGEST_A** to **SHA_IDIGEST_E** registers for SHA-1
- **SHA_IDIGEST_A** to **SHA_IDIGEST_H** registers for SHA-2

When **ALGO_CONSTANT** = 1 in the **SHA_MODE** register, the **SHA Inner Digest n (SHA_IDIGEST_n)** registers do not need to be written by the application because they are overwritten with the appropriate algorithm constants.

When **HMAC_KEY_PROC** is 1, these registers must be written with the upper 256 bits of the HMAC key to be processed in little-endian format (first byte of key string in bits [7:0]).

Note: If the HMAC key is less than 512 bits, it must be properly padded with zeros: all 16 HMAC key registers must be written explicitly; the core does not pad. Additionally, if the HMAC key is larger than 512 bits, the host must perform a preprocessing step to reduce it to one 512-bit block. This involves hashing the large key and padding the hash result with zeros until it is 512 bits wide.

The order of the bytes within the digest is such that it can be fed back unmodified into the little-endian data input when preprocessing HMAC keys larger than 64 bytes, or it can typically be inserted unmodified into a little-endian data stream (for example, IPSEC packets), regardless of the selected algorithm.

Note: The HMAC key or inner digest is not preserved. If another block must be authenticated using the same key, the key or inner digest must be reloaded by the host. If the same key must be used many times, it is advisable to do a HMAC key processing-only pass to obtain the inner and outer digest precomputes and load these precomputes for subsequent passes (only the inner digest must be reloaded if the outer digest is not modified by the host), because this saves two hash blocks worth of computation time.

Closing a Hash

The amount of data to hash is not necessarily a multiple of 64 bytes. The **CLOSE_HASH** bit in the **SHA_MODE** register is set to append padding so that the message size becomes a multiple of 64 bytes. Consequently, a minimum of 9 bytes must be added to the message. Nine bytes is the minimum number of bytes that contains the minimum 65-bit padding specified by FIPS 180-1.

If the size of the last block of data is less than or equal to 55 bytes, no additional 64-byte block is required. However, if the last block of data contains more than 55 bytes, an extra 64-byte block must be added to make the padding as specified by FIPS 180-1. This extra block is added automatically by the hardware; thus, the module is fed with a 64-byte block of data. However, appending a pad on the last block of data can result in the creation of an extra 64-byte block.

The one or two last blocks that contain the padding are processed in the same way as the other blocks. Hash completion is then indicated in the same way as for a new hash, and the hash result can be read in the digest registers. The **SHA_DIGESTCOUNT** register returns restored Digest Count + Length when it is read, and hashing completes.

Assuming a message of 129 bytes, Table 15-5 on page 1051 shows the SHA digest for three passes. Table 15-6 on page 1051 shows the SHA digest for one pass.

Table 15-5. SHA Digest Processed in Three Passes

	Digest (A to E)	SHA_DIGESTCOUNT	SHA_MODE and SHA_LENGTH	SHA_DATA_n_IN
First pass			WRITE: LENGTH=64 ALGO (dependent on the algorithm to apply) ALGO_CONSTANT=1 CLOSE_HASH=0	First 64 bytes of message
Second pass	Round 1 digest calculation	WRITE: 64	WRITE: LENGTH=64 ALGO (dependent on the algorithm to apply) ALGO_CONSTANT=0 CLOSE_HASH=0	Second 64 bytes of message
Third pass	Round 2 digest calculation	WRITE: 128	Write: LENGTH=1 ALGO (dependent on the algorithm to apply) ALGO_CONSTANT=0 CLOSE_HASH=1	Last byte of message
	Final digest	READ: 129		

If the three passes are not performed in succession, the digest registers must be saved and restored for the next use of the SHA/MD5 engine. If the rounds are performed consecutively, there is no need to do anything with the digest registers.

Table 15-6. SHA Digest Processed in One Pass

	Digest (A to E)	SHA_DIGEST_COUNT	SHA_MODE and SHA_LENGTH	SHA_DATA_n_IN
First pass			WRITE: LENGTH=129 ALGO (dependent on the algorithm to apply) ALGO_CONSTANT=1 CLOSE_HASH=1	First 64 bytes of message

Table 15-6. SHA Digest Processed in One Pass (continued)

	Digest (A to E)	SHA_DIGEST_COUNT	SHA_MODE and SHA_LENGTH	SHA_DATA_n_IN
	Round 1 digest calculation			Second 64 bytes of message
	Round 2 digest calculation			Last byte of message
	Final digest	Read: 129		

15.1.5.2 MD5 Mode

Starting a New Hash

To start a new hash, perform the following steps:

1. Set the **ALGO** bit field in the **SHA_MODE** register to 0x0 to select the MD5 algorithm.
2. Set the **ALGO_CONSTANT** bit to 1 in the **SHA_MODE** register to initialize all digest registers from **SHA_ODIGEST_A/SHA_IDIGEST_A** to **SHA_ODIGEST_H/SHA_IDIGEST_H** with default values specified by the algorithm, and set the **SHA_DIGESTCOUNT** register to 0.
3. Specify the **LENGTH** field in the **SHA_LENGTH** register of the hash data to process in bytes.
4. Set the **CLOSE_HASH** bit in the **SHA_MODE** register to let the SHA/MD5 engine do the padding. If MD5 is computed in one shot, the length of the message can be any value up to . To process an intermediate MD5 digest, the **CLOSE_HASH** bit is set to 0, in which case packets to be hashed must be 64 bytes; the last packet must be hashed with the **CLOSE_HASH** bit set to 1.

After the configuration is complete, the hash engine can receive the data to process (the **INPUT_READY** bit is 1 in the **SHA_IRQSTATUS** register). Data must be written to the 16 x 32-bit **SHA_DATA_n_IN** registers that provide storage for one 64-byte block of data. Unless the **CLOSE_HASH** bit is set in the **SHA_MODE** register, the **SHA_DATA_n_IN** 64-byte input buffer must be filled. Data can be written by single write transactions to the 16 registers from a processor or by a μ DMA transfer.

For a μ DMA transfer, the **SDAM_EN** bit must be set in the **SHA_SYSCONFIG** register before starting the new hash and the μ DMA channel for SHA/MD5 0 Data In Request must be configured. The μ DMA must be configured to the appropriate hash transfer size. See “Micro Direct Memory Access (μ DMA)” on page 686 for more information on programming the μ DMA. A μ DMA done is asserted after the last **SHA_DATA_n_IN** register is filled..

The module detects that a 64-byte block is available, and then moves the data to a working register space for processing and sets the **INPUT_READY** bit to 1 in the **SHA_IRQSTATUS** register. If the **DMA_EN** bit is set in the **SHA_SYSCONFIG** register, then a new μ DMA request triggers a new block transfer; otherwise, the processor polls the **INPUT_READY** bit in the **SHA_IRQSTATUS** register and writes the 16 data words of 32 bits when it equals 1.

This operation repeats until the length of the message to hash is reached. The **OUTPUT_READY** bit in the **SHA_IRQSTATUS** register then indicates that the hash operation is complete. If the **IT_EN** bit in the **SHA_SYSCONFIG** register is set, an interrupt (active low) is also generated to indicate the hash completion.

Closing a Hash

The amount of data to hash is not necessarily a multiple of 64 bytes. In this case, the CLOSE_HASH bit in the SHA_MODE register must be set to append padding so that the message size becomes a multiple of 64 bytes. See the previous MD5 algorithm for more information on padding.

The module is fed with a 64-byte block of data, as long as enough data is available. However, a pad is appended on the last block of data. This can result in the creation of an extra 64-byte block.

The one or two last blocks that contain the padding are processed the same way as the other blocks. Hash completion is then indicated the same way as for a new hash, and the 128-bit result can be read in the digest registers. The **SHA_DIGESTCOUNT** register returns restored digest count and length when it is read, and hashing completes.

15.1.5.3 Generating an Software Interrupt

If the **IT_EN** bit is 1 in the **SHA_SYSCONFIG** register, an interrupt is generated at the completion of the hash by the following steps:

1. Receive last block of data (= 64 bytes). (The number of data bytes defined by the **SHA_LENGTH** register is received in the digest registers, from **SHA_ODIGEST_A/SHA_IDIGEST_A** to **SHA_ODIGEST_H/SHA_IDIGEST_H**.)
2. If required, apply padding to the last block of data.
3. Hash the last block of data (80 cycles in SHA-1 mode and 64 cycles in MD5, SHA-224, and SHA-256 modes).
4. If required, add an extra 64-byte block of data to complete the padding.
5. Hash this extra block of data (80 cycles in SHA-1 mode and 64 cycles in MD5, SHA-224, and SHA-256 modes).
6. An interrupt is generated (active low).

15.1.6 SHA/MD5 Performance Information

The following table lists the performance for all supported key sizes and modes of operations. It assumed that the engine is kept fully utilized (that is, the host is supplying input block and retrieving output blocks in such a way, that the engine never has to wait for input) and that the previous output has been retrieved before the next output is ready.

Maximum throughput does not include per operation overhead cycles, as the impact on the throughput depends on the size of the block being processed, and would be negligible for large blocks anyway.

Table 15-7. SHA/MD5 Performance

Operation	Algorithm	Cycles per operation	Cycles per block
Hash	MD5	0 / 65	65
	SHA-1	0 / 81	81
	SHA-224	0 / 65	65
	SHA-256	0 / 65	65

Table 15-7. SHA/MD5 Performance (continued)

Operation	Algorithm	Cycles per operation	Cycles per block
HMAC from Key	MD5	196 / 261	65
	SHA-1	244 / 325	81
	SHA-224	196 / 261	65
	SHA-256	196 / 261	65
	MD5	66 / 131	65
HMAC from precomputes	SHA-1	82 / 163	81
	SHA-224	66 / 131	65
	SHA-256	66 / 131	65

Note: An extra block needs to be processed if the length of the data block to be hashed module 64 is 0 or equal to 56.

15.1.7 SHA/MD5 Programming Guide

This section covers the hardware programming sequences for configuration and use of the SHA/MD5 Module.

15.1.7.1 Global Initialization

Surrounding Modules Global Initialization

This section identifies the requirements for initializing the surrounding modules when the SHAM is used for the first time after a device reset.

1. When reset has completed, enable the SHA/MD5 Module by setting the `R0` bit in the **CRC And Cryptographic Modules Run Mode Clock Gating Control (RCGCCM)** register, System Control offset 0x674. When the `R0` bit is set in the **CRC and Cryptographic Modules (PRCCM)** register, System Control offset 0xA74 register, the SHA/MD5 Module is powered and ready to be configured.
2. Configure the SHA μ DMA channels for Context In, Context Out, Data In, and/or Data Out by programming the appropriate encoding value in the **DMA Channel Map Select n (DMACHMAPn)** register in the μ DMA module, offset 0x510. For more information on how to program channel assignments as well as enabling burst and the configured channels, refer to “Micro Direct Memory Access (μ DMA)” on page 686.
3. Execute a software reset by setting the `SOFTRESET` bit in the **SHA_SYSCONFIG** register. When reset is complete, the `RESETDONE` bit reads as 1 in the **SHA_SYSSTATUS** register.
4. If the SHA channels are configured in the μ DMA, enable the required SHA DMA requests by programming bits [9:5] of the **SHA_SYSCONFIG** register, in addition to the completion interrupts in the **SHA DMA Interrupt Mask (SHA_DMAIM)** register, CRC and Cryptographic Modules offset 0x020.

Starting a New HMAC using the SHA-1 Hash Function and HMAC Key Processing

The following procedure is used to begin a new HMAC operation, starting from initial digest values.

1. Load the key value in the **SHA_ODIGEST_A/SHA_IDIGEST_A** to **SHA_ODIGEST_H/SHA_IDIGEST_H** registers.

2. Pad the rest of the SHA_ODIGEST_x and SHA_IDIGEST registers with zeros.
3. Load the message in the **SHA_DATA_n_IN** FIFO registers.
4. Enable HMAC key processing by setting the HMAC_KEY_PROC bit in the **SHA_MODE** register.
5. Select the SHA-1 hash function by programming the ALGO bit in the **SHA_MODE** register to 0x1.
6. Select the already loaded key by programming the ALGO_CONSTANT bit in the SHA_MODE register to 0x0.
7. Set the CLOSE_HASH bit and the HMAC_OUTER_HASH bit in the **SHA_MODE** register so that appropriate padding is inserted and the outer hash is performed immediately after the inner hash has finished.
8. Program the **SHA_LENGTH** register with the block length. Writing this register triggers the HMAC engine to begin processing.

Note: If more than one pass is used during the process (SHA_MODE[4] CLOSE_HASH == 0x0), the block length value must be a 64-byte multiple. From this point, three operational modes are possible to continue with the processing: polling, interrupt, and DMA. For more information, see the Operational Modes Configuration section.

Subsequence - Continuing a Prior HMAC Using the SHA-1 Hash Function

The procedure in continues a prior HMAC calculation interrupted from a high priority task.

Table 15-8. Continuing a Prior HMAC

Step	Register/Bit Field/Programming Model	Value
Load the initial digest for the used hash algorithm.	SHA_IDIGEST_i[31:0] DATA	-
Restore the digest counter with the value before the switch to the high-priority task.	SHA_DIGEST_COUNT[31:0] COUNT	-
Use the already loaded in the engine key.	SHA_MODE[5] HMAC_KEY_PROC	0x0
Do not use the constants of the selected hash algorithm.	SHA_MODE[3] ALGO_CONSTANT	0x0
Select the SHA-1 hash algorithm.	SHA_MODE[2:1] ALGO	0x1
IF: This is the last 64-byte data block from the input message?	User decision	
Close the hash; an appropriate padding is added.	SHA_MODE[4] CLOSE_HASH	0x1
ENDIF		
Load the block length; this is the trigger to start processing.	SHA_LENGTH[31:0] LENGTH	-

Note: This initial digest is the intermediate digest from the previous calculation before switching to the high priority task. The value is equal to context1 in .

Note: The value is equal to context2 in .

Note: The block length is equal to the context3 value in .

Subsequence - Hashing a Key Bigger than 512 Bits with the SHA-1 Hash Function

The procedure in creates a hash value from the key in only one pass.

Table 15-9. SHA-1 Apply on the Key

Step	Register/Bit Field/Programming Model	Value
Load the first part of the key. (Here, the key is like a message.)	SHA_DATA_n_IN (i = 0 to 15)	-
Select the SHA-1 hash function.	SHA_MODE[2:1] ALGO	0x1
Select a new hash operation.	SHA_MODE[3] ALGO_CONSTANT	0x1
Close the hash; the key is processed in single pass.	SHA_MODE[4] CLOSE_HASH	0x1

Operational Modes Configuration

SHA/MD5 Polling Mode

Figure 15-2 on page 1056 shows the SHA/MD5 polling mode. SHA/MD5 polling mode uses the following registers: SHA_IRQSTATUS, SHA_DATA_n_IN, SHA_ODIGEST_A, SHA_DIGEST_COUNT, and SHA_LENGTH.

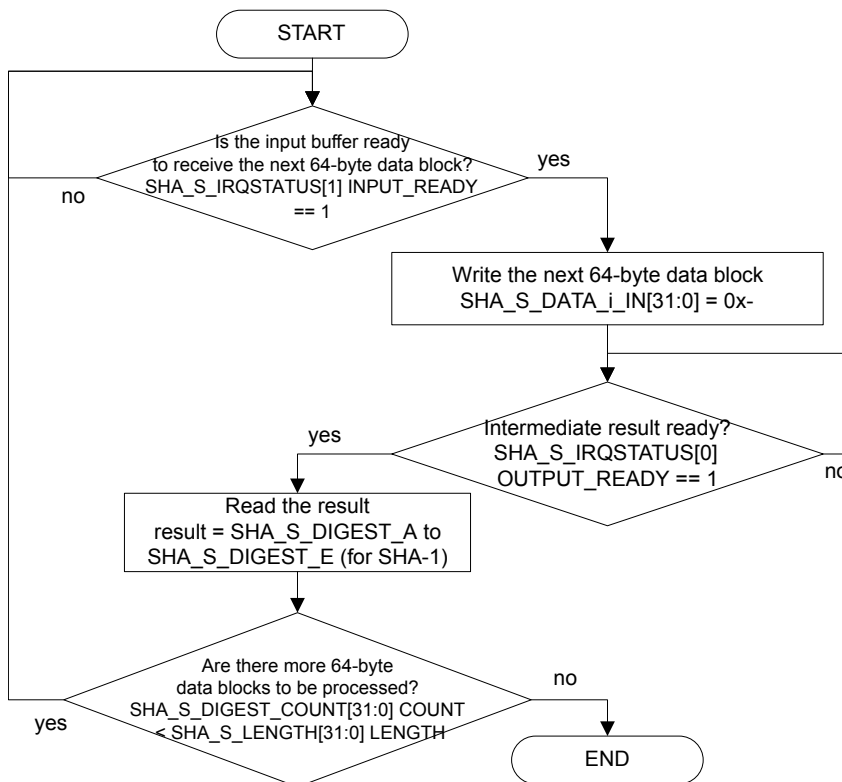
Figure 15-2. SHA/MD5 Polling Mode

SHA/MD5 Interrupt Mode

The procedure in configures the SHA/MD5 module to work in interrupt-based mode. (For the interrupt subroutine, see the Interrupt Servicing section.)

Table 15-10. Interrupt Mode

Step	Register/Bit Field/Programming Model	Value
Enable the interrupt request to the Cortex-A8 MPU INTC.	SHA_SYSCONFIG[2] IT_EN	0x1

Table 15-10. Interrupt Mode (continued)

Step	Register/Bit Field/Programming Model	Value
Load the message length; this is the trigger to start processing.	SHA_LENGTH[31:0] LENGTH	-

SHA/MD5 DMA Mode

The procedure in configures the SHA/MD5 module to work in DMA-based mode.

Table 15-11. DMA Mode

Step	Register/Bit Field/Programming Model	Value
Enable the DMA request to the CDMA controller.	SHA_SYSCONFIG[3] DMA_EN	0x1
Load the message length; this is the trigger to start processing.	SHA_LENGTH[31:0] LENGTH	-

SHA/MD5 Event Servicing**Interrupt Servicing**

This section describes the interrupt event servicing of the module. Figure 15-3 on page 1058 shows the interrupt subroutine. The following registers are used in the SHA/MD5 interrupt routine: SHA_IRQSTATUS, SHA_DATA_n_IN, SHA_ODIGEST_A, SHA_DIGEST_COUNT, SHA_LENGTH, and SHA_IDIGEST_A.

Figure 15-3. SHA/MD5 Interrupt Subroutine

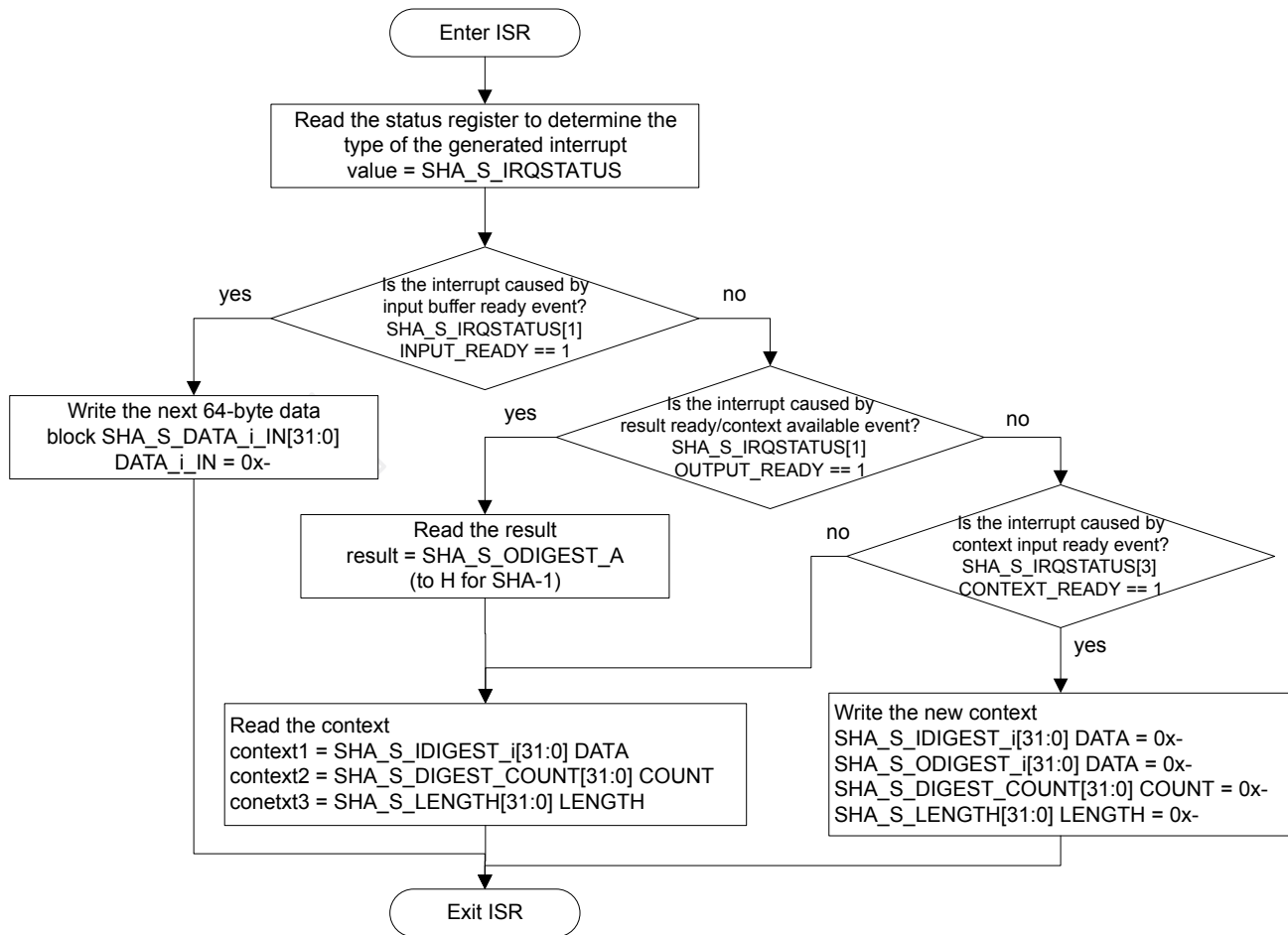

15.2 SHA/MD5 Register Map

Table 15-12 on page 1058 lists the SHA/MD5 registers. The SHA Module comprises registers that exist at an offset relative to the SHA/MD5 Module base address and a small set of SHA/MD5 μ DMA interrupt registers that exist at an offset relative to an CRC and Cryptographic Modules base address. The SHA/MD5 Module register offsets are relative to the base address 0x4403.4000. The SHA μ DMA offsets are relative to the base address 0x4403.0000 .

Table 15-12. SHA/MD5 Register Map

Offset	Name	Type	Reset	Description	See page
SHA/MD5 Module Registers (SHA/MD5 Module Offset)					
0x000	SHA_ODIGEST_A	RW	0x0000.0000	SHA Outer Digest A	1062
0x004	SHA_ODIGEST_B	RW	0x0000.0000	SHA Outer Digest B	1062
0x008	SHA_ODIGEST_C	RW	0x0000.0000	SHA Outer Digest C	1062
0x00C	SHA_ODIGEST_D	RW	0x0000.0000	SHA Outer Digest D	1062

Table 15-12. SHA/MD5 Register Map (continued)

Offset	Name	Type	Reset	Description	See page
0x010	SHA_ODIGEST_E	RW	0x0000.0000	SHA Outer Digest E	1062
0x014	SHA_ODIGEST_F	RW	0x0000.0000	SHA Outer Digest F	1062
0x018	SHA_ODIGEST_G	RW	0x0000.0000	SHA Outer Digest G	1062
0x01C	SHA_ODIGEST_H	RW	0x0000.0000	SHA Outer Digest H	1062
0x020	SHA_IDIGEST_A	RW	0x0000.0000	SHA Inner Digest A	1062
0x024	SHA_IDIGEST_B	RW	0x0000.0000	SHA Inner Digest B	1062
0x028	SHA_IDIGEST_C	RW	0x0000.0000	SHA Inner Digest C	1062
0x02C	SHA_IDIGEST_D	RW	0x0000.0000	SHA Inner Digest D	1062
0x030	SHA_IDIGEST_E	RW	0x0000.0000	SHA Inner Digest E	1062
0x034	SHA_IDIGEST_F	RW	0x0000.0000	SHA Inner Digest F	1062
0x038	SHA_IDIGEST_G	RW	0x0000.0000	SHA Inner Digest G	1062
0x03C	SHA_IDIGEST_H	RW	0x0000.0000	SHA Inner Digest H	1062
0x040	SHA_DIGEST_COUNT	RW	0x0000.0000	SHA Digest Count	1063
0x044	SHA_MODE	RW	0x0000.0000	SHA Mode	1064
0x048	SHA_LENGTH	RW	0x0000.0000	SHA Length	1066
0x080	SHA_DATA_0_IN	RW	0x0000.0000	SHA Data 0 Input	1067
0x084	SHA_DATA_1_IN	RW	0x0000.0000	SHA Data 1 Input	1067
0x088	SHA_DATA_2_IN	RW	0x0000.0000	SHA Data 2 Input	1067
0x08C	SHA_DATA_3_IN	RW	0x0000.0000	SHA Data 3 Input	1067
0x090	SHA_DATA_4_IN	RW	0x0000.0000	SHA Data 4 Input	1067
0x094	SHA_DATA_5_IN	RW	0x0000.0000	SHA Data 5 Input	1067
0x098	SHA_DATA_6_IN	RW	0x0000.0000	SHA Data 6 Input	1067
0x09C	SHA_DATA_7_IN	RW	0x0000.0000	SHA Data 7 Input	1067
0x0A0	SHA_DATA_8_IN	RW	0x0000.0000	SHA Data 8 Input	1067
0x0A4	SHA_DATA_9_IN	RW	0x0000.0000	SHA Data 9 Input	1067
0x0A8	SHA_DATA_10_IN	RW	0x0000.0000	SHA Data 10 Input	1067
0x0AC	SHA_DATA_11_IN	RW	0x0000.0000	SHA Data 11 Input	1067
0x0B0	SHA_DATA_12_IN	RW	0x0000.0000	SHA Data 12 Input	1067
0x0B4	SHA_DATA_13_IN	RW	0x0000.0000	SHA Data 13 Input	1067
0x0B8	SHA_DATA_14_IN	RW	0x0000.0000	SHA Data 14 Input	1067
0x0BC	SHA_DATA_15_IN	RW	0x0000.0000	SHA Data 15 Input	1067
0x100	SHA_REVISION	RO	0x40000C03	SHA Revision	1068

Table 15-12. SHA/MD5 Register Map (continued)

Offset	Name	Type	Reset	Description	See page
0x110	SHA_SYSCONFIG	RW	0x0000.0001	SHA System Configuration	1069
0x114	SHA_SYSSTATUS	RO	0x0000.0001	SHA System Status	1071
0x118	SHA_IRQSTATUS	RO	0x0000.0008	SHA Interrupt Status	1072
0x11C	SHA_IRQENABLE	RW	0x0000.0007	SHA Interrupt Enable	1073
Encryption Control (Encryption Control Offset)					
0x010	SHA_DMAIM	RW	0x0000.0000	SHA DMA Interrupt Mask	1075
0x014	SHA_DMARIS	RO	0x0000.0000	SHA DMA Raw Interrupt Status	1076
0x018	SHA_DMAMIS	RO	0x0000.0000	SHA DMA Masked Interrupt Status	1077
0x01C	SHA_DMAIC	W1C	0x0000.0000	SHA DMA Interrupt Clear	1078

15.3 SHA/MD5 Register Descriptions

This section describes the SHA/MD5 registers.

Note: The SHA/MD5 registers are limited to 32-bit data accesses; 8- and 16-bit accesses are not allowed and can corrupt register contents.

The first 16 registers of HIB1 are the outer and inner digest registers.

Table 15-13. SHA/MD5 Inner/Outer Digest/HMAC Key Register Mapping

Register Name	Address Offset	MD5 (read/write)	SHA-1 (read/write)	SHA-2 (read/write)		HMAC key proc (write)
SHA_ODIGEST_A	0x00000000	Outer digest [127:96]	Outer digest [159:128]	Outer digest [255:224]		HMAC key [31,0]
SHA_ODIGEST_B	0x00000004	Outer digest [95:64]	Outer digest [127:96]	Outer digest [223:192]		HMAC key [63,32]
SHA_ODIGEST_C	0x00000008	Outer digest [63:32]	Outer digest [95:64]	Outer digest [191:160]		HMAC key [95,64]
SHA_ODIGEST_D	0x0000000C	Outer digest [31:0]	Outer digest [63:32]	Outer digest [159:128]		HMAC key [127,96]
SHA_ODIGEST_E	0x00000010		Outer digest [31:0]	Outer digest [127:96]		HMAC key [159,128]
SHA_ODIGEST_F	0x00000014			Outer digest [95:64]		HMAC key [191,160]
SHA_ODIGEST_G	0x00000018			Outer digest [63:32]		HMAC key [223,192]
SHA_ODIGEST_H	0x0000001C			Outer digest [31:0]		HMAC key [255,224]
SHA_IDIGEST_A	0x00000020	Inner digest [127:96]	Inner digest [159:128]	Inner digest [223:192]	Inner digest [255:224]	HMAC key [287,256]
SHA_IDIGEST_B	0x00000024	Inner digest [95:64]	Inner digest [127:96]	Inner digest [191:160]	Inner digest [223:192]	HMAC key [319,288]
SHA_IDIGEST_C	0x00000028	Inner digest [63:32]	Inner digest [95:64]	Inner digest [159:128]	Inner digest [191:160]	HMAC key [351,320]

Table 15-13. SHA/MD5 Inner/Outer Digest/HMAC Key Register Mapping (continued)

Register Name	Address Offset	MD5 (read/write)	SHA-1 (read/write)	SHA-2 (read/write)		HMAC key proc (write)
SHA_IDIGEST_D	0x0000002C	Inner digest [31:0]	Inner digest [63:32]	Inner digest [127:96]	Inner digest [159:128]	HMAC key [383,352]
SHA_IDIGEST_E	0x00000030		Inner digest[31:0]	Inner digest [95:64]	Inner digest [127:96]	HMAC key [415,384]
SHA_IDIGEST_F	0x00000034			Inner digest [63:32]	Inner digest [95:64]	HMAC key [447,416]
SHA_IDIGEST_G	0x00000038			Inner digest [31:0]	Inner digest [63:32]	HMAC key [479,448]
SHA_IDIGEST_H	0x0000003C				Inner digest[31:0]	HMAC key [511,480]

- Register 1: SHA Outer Digest A (SHA_ODIGEST_A), offset 0x000**
Register 2: SHA Outer Digest B (SHA_ODIGEST_B), offset 0x004
Register 3: SHA Outer Digest C (SHA_ODIGEST_C), offset 0x008
Register 4: SHA Outer Digest D (SHA_ODIGEST_D), offset 0x00C
Register 5: SHA Outer Digest E (SHA_ODIGEST_E), offset 0x010
Register 6: SHA Outer Digest F (SHA_ODIGEST_F), offset 0x014
Register 7: SHA Outer Digest G (SHA_ODIGEST_G), offset 0x018
Register 8: SHA Outer Digest H (SHA_ODIGEST_H), offset 0x01C
Register 9: SHA Inner Digest A (SHA_IDIGEST_A), offset 0x020
Register 10: SHA Inner Digest B (SHA_IDIGEST_B), offset 0x024
Register 11: SHA Inner Digest C (SHA_IDIGEST_C), offset 0x028
Register 12: SHA Inner Digest D (SHA_IDIGEST_D), offset 0x02C
Register 13: SHA Inner Digest E (SHA_IDIGEST_E), offset 0x030
Register 14: SHA Inner Digest F (SHA_IDIGEST_F), offset 0x034
Register 15: SHA Inner Digest G (SHA_IDIGEST_G), offset 0x038
Register 16: SHA Inner Digest H (SHA_IDIGEST_H), offset 0x03C

PKA Status Register

SHA Outer Digest n (SHA_ODIGEST_n)

Base 0x4403.4000
 Offset 0x000
 Type RW, reset 0x0000.0000

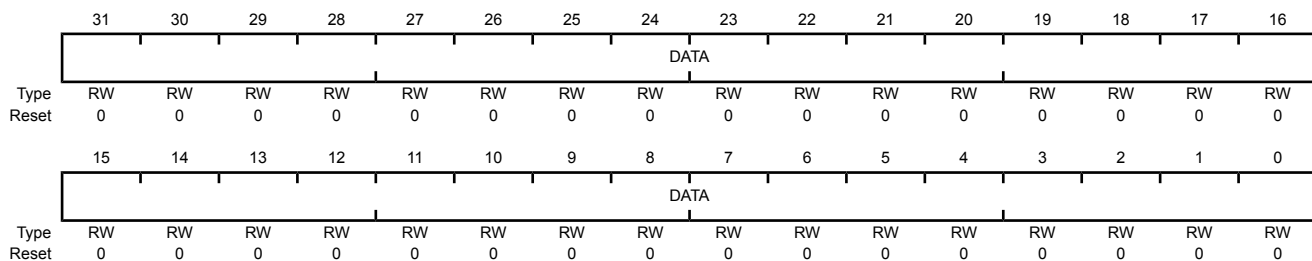

Bit/Field	Name	Type	Reset	Description
31:0	DATA	RW	0x0000.0000	Digest/Key Data

Register 17: SHA Digest Count (SHA_DIGEST_COUNT), offset 0x040

This register is written with the initial digest count and can be read to determine the digest count result. Note that for Initial Digest Count writes, bits 5:0 must be zero. This register is written the initial digest byte count when both the `HMAC_KEY_PROC` bit and the `ALGO_CONSTANT` bit is zero in the `SHA_MODE` register. When either the `HMAC_KEY_PROC` bit or the `ALGO_CONSTANT` bit is 1, this register does not need to be written because it is overwritten with 64 or 0 automatically. When starting an HMAC operation from precomputes (`HMAC_KEY_PROC=0`), the value 64 must be written in the `SHA_DIGESTCOUNT` register. Note that the value written should always be a 64 byte multiple, the lower 6 bits written are ignored. The updated digest byte count (initial digest byte count + bytes processed) can be read from this register when the status register indicates that the operation is done or when a μ DMA context out is requested.

SHA Digest Count (SHA_DIGEST_COUNT)

Base 0x4403.4000
Offset 0x040
Type RW, reset 0x0000.0000

	31	30	29	28	27	26	25	24	23	22	21	20	19	18	17	16
	COUNT															
Type	RW	RW	RW	RW	RW	RW	RW	RW	RW	RW	RW	RW	RW	RW	RW	RW
Reset	0	0	0	0	0	0	0	0	0	0	0	0	0	0	0	0
	15	14	13	12	11	10	9	8	7	6	5	4	3	2	1	0
	COUNT															
Type	RW	RW	RW	RW	RW	RW	RW	RW	RW	RW	RW	RW	RW	RW	RW	RW
Reset	0	0	0	0	0	0	0	0	0	0	0	0	0	0	0	0

Bit/Field	Name	Type	Reset	Description
31:0	COUNT	RW	0x0000.0000	Digest Count This field is written with the initial digest value for bits [31:6] only ([5:0] are assumed to be zeros). When read, this outputs the result/intermediate digest count.

Register 18: SHA Mode (SHA_MODE), offset 0x044

This register is written to configure the hash algorithm to be used in the hash operation.

SHA Mode (SHA_MODE)

Base 0x4403.4000

Offset 0x044

Type RW, reset 0x0000.0000

	31	30	29	28	27	26	25	24	23	22	21	20	19	18	17	16
	reserved															
Type	RO	RO	RO	RO	RO	RO	RO	RO	RO	RO	RO	RO	RO	RO	RO	RO
Reset	0	0	0	0	0	0	0	0	0	0	0	0	0	0	0	0
	15	14	13	12	11	10	9	8	7	6	5	4	3	2	1	0
	reserved								HMAC_OUTER_HASH	reserved	HMAC_KEY_PROC	CLOSE_HASH	ALGO_CONSTANT	ALGO		
Type	RO	RO	RO	RO	RO	RO	RO	RO	RW	R	RW	RW	RW	RW	RW	RW
Reset	0	0	0	0	0	0	0	0	0	0	0	0	0	0	0	0

Bit/Field	Name	Type	Reset	Description				
31:8	reserved	RO	0	Software should not rely on the value of a reserved bit. To provide compatibility with future products, the value of a reserved bit should be preserved across a read-modify-write operation.				
7	HMAC_OUTER_HASH	RW	0	<p>HMAC Outer Hash Processing Enable</p> <p>This bit is written to indicate that the outer hash should be performed on the hash digest when the inner hash has finished. The inner hash finishes when the length of hash has been processed the final inner hash is performed (if <code>CLOSE_HASH</code> was set to 1).</p> <p>This bit should normally be set together with <code>CLOSE_HASH</code> to finish the inner hash first, or immediately when block length is zero (HMAC continue with the just outer hash to be done). This bit is auto-cleared when outer hash is finished.</p> <p>Value Description</p> <table border="0"> <tr> <td>0</td> <td>No operation</td> </tr> <tr> <td>1</td> <td>Enable HMAC processing of outer hash.</td> </tr> </table> <p>This bit self-clears when outer hash is finished.</p>	0	No operation	1	Enable HMAC processing of outer hash.
0	No operation							
1	Enable HMAC processing of outer hash.							
6	reserved	R	0	Software should not rely on the value of a reserved bit. To provide compatibility with future products, the value of a reserved bit should be preserved across a read-modify-write operation.				

Bit/Field	Name	Type	Reset	Description																
5	HMAC_KEY_PROC	RW	0x00	<p>HMAC Key Processing Enable</p> <p>This bit enables HMAC key processing on the 512-bit HMAC key loaded into the SHA_IDIGEST_A through SHA_IDIGEST_H registers and the SHA_ODIGEST_A through SHA_ODIGEST_H register block. Once HMAC key processing is finished, this bit is automatically cleared and the resulting Inner and Outer digest is available in the SHA_IDIGEST_x and SHA_ODIGEST_x respectively.</p> <p>After key processing is complete, regular hash processing begins until the block length is exhausted.</p> <p>Value Description</p> <table border="1"> <tr> <td>0</td> <td>No operation</td> </tr> <tr> <td>1</td> <td>Enable HMAC key processing. This bit is automatically cleared once HMAC key processing is finished.</td> </tr> </table>	0	No operation	1	Enable HMAC key processing. This bit is automatically cleared once HMAC key processing is finished.												
0	No operation																			
1	Enable HMAC key processing. This bit is automatically cleared once HMAC key processing is finished.																			
4	CLOSE_HASH	RW	0	<p>Performs the padding, the Hash/HMAC will be 'closed' at the end of the block, as per MD5/SHA-1/SHA-2 specification (that is, appropriate padding is added), or no padding is done, allowing the hash to be continued later. However, if the Hash/HMAC is not closed, then the Block Length must be a multiple of 64 bytes to ensure correct operation. Auto cleared internally when hash closed.</p> <p>Value Description</p> <table border="1"> <tr> <td>0</td> <td>No padding, hash computation can be continued.</td> </tr> <tr> <td>1</td> <td>Last packet will be padded.</td> </tr> </table>	0	No padding, hash computation can be continued.	1	Last packet will be padded.												
0	No padding, hash computation can be continued.																			
1	Last packet will be padded.																			
3	ALGO_CONSTANT	RW	0	<p>The initial digest register will be overwritten with the algorithm constants for the selected algorithm when hashing and the initial digest count register will be reset to 0. This will start a normal hash operation. When continuing an existing hash or when performing an HMAC operation, this register must be set to 0 and the intermediate/inner digest or HMAC key and digest count need to be written to the context input registers prior to writing SHA_MODE. Auto cleared internally after first block processed.</p> <p>Value Description</p> <table border="1"> <tr> <td>0</td> <td>Use precalculated digest (from another operation)</td> </tr> <tr> <td>1</td> <td>Use constants of the selected algorithm</td> </tr> </table>	0	Use precalculated digest (from another operation)	1	Use constants of the selected algorithm												
0	Use precalculated digest (from another operation)																			
1	Use constants of the selected algorithm																			
2:0	ALGO	RW	0x0	<p>Hash Algorithm</p> <p>Value Description</p> <table border="1"> <tr> <td>0x0</td> <td>MD5</td> </tr> <tr> <td>0x1</td> <td>reserved</td> </tr> <tr> <td>0x2</td> <td>SHA-1</td> </tr> <tr> <td>0x3</td> <td>reserved</td> </tr> <tr> <td>0x4</td> <td>SHA-224</td> </tr> <tr> <td>0x5</td> <td>reserved</td> </tr> <tr> <td>0x6</td> <td>SHA-256</td> </tr> <tr> <td>0x7</td> <td>reserved</td> </tr> </table>	0x0	MD5	0x1	reserved	0x2	SHA-1	0x3	reserved	0x4	SHA-224	0x5	reserved	0x6	SHA-256	0x7	reserved
0x0	MD5																			
0x1	reserved																			
0x2	SHA-1																			
0x3	reserved																			
0x4	SHA-224																			
0x5	reserved																			
0x6	SHA-256																			
0x7	reserved																			

Register 19: SHA Length (SHA_LENGTH), offset 0x048

WRITE: Block Length/Remaining Byte Count (bytes) READ: Remaining Byte Count. The value programmed MUST be a 64-byte multiple if Close Hash is set to 0. This register is also the trigger to start processing: once this register is written, the core will commence requesting input data via DMA or IRQ (if programmed length > 0) and start processing. The remaining byte count for the active operation can be read from this register when the interrupt status register indicates that the operation is suspended due to a context switch request.

SHA Length (SHA_LENGTH)

Base 0x4403.4000

Offset 0x048

Type RW, reset 0x0000.0000

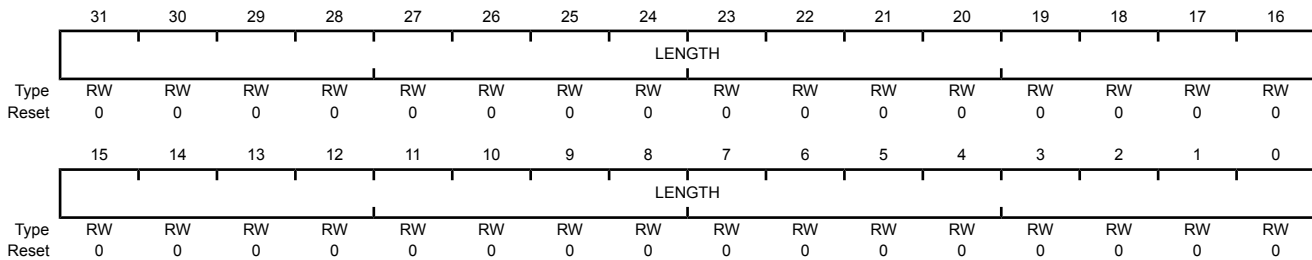

Bit/Field	Name	Type	Reset	Description
31:0	LENGTH	RW	0x0000.0000	Block Length/Remaining Byte Count This field is written with the block length in bytes of the data to be processed. When read, this field contains the remaining byte count.

- Register 20: SHA Data 0 Input (SHA_DATA_0_IN), offset 0x080**
Register 21: SHA Data 1 Input (SHA_DATA_1_IN), offset 0x084
Register 22: SHA Data 2 Input (SHA_DATA_2_IN), offset 0x088
Register 23: SHA Data 3 Input (SHA_DATA_3_IN), offset 0x08C
Register 24: SHA Data 4 Input (SHA_DATA_4_IN), offset 0x090
Register 25: SHA Data 5 Input (SHA_DATA_5_IN), offset 0x094
Register 26: SHA Data 6 Input (SHA_DATA_6_IN), offset 0x098
Register 27: SHA Data 7 Input (SHA_DATA_7_IN), offset 0x09C
Register 28: SHA Data 8 Input (SHA_DATA_8_IN), offset 0x0A0
Register 29: SHA Data 9 Input (SHA_DATA_9_IN), offset 0x0A4
Register 30: SHA Data 10 Input (SHA_DATA_10_IN), offset 0x0A8
Register 31: SHA Data 11 Input (SHA_DATA_11_IN), offset 0x0AC
Register 32: SHA Data 12 Input (SHA_DATA_12_IN), offset 0x0B0
Register 33: SHA Data 13 Input (SHA_DATA_13_IN), offset 0x0B4
Register 34: SHA Data 14 Input (SHA_DATA_14_IN), offset 0x0B8
Register 35: SHA Data 15 Input (SHA_DATA_15_IN), offset 0x0BC

Data input message

Note: The **SHA_DATA_n_IN_0** register acts as a FIFO and shifts data into the other **SHA_DATA_n_IN** registers.

SHA Data n Input (SHA_DATA_n_IN)

Base 0x4403.4000
 Offset 0x080
 Type RW, reset 0x0000.0000

	31	30	29	28	27	26	25	24	23	22	21	20	19	18	17	16
	DATA_IN															
Type	RW	RW	RW	RW	RW	RW	RW	RW	RW	RW	RW	RW	RW	RW	RW	RW
Reset	0	0	0	0	0	0	0	0	0	0	0	0	0	0	0	0
	15	14	13	12	11	10	9	8	7	6	5	4	3	2	1	0
	DATA_IN															
Type	RW	RW	RW	RW	RW	RW	RW	RW	RW	RW	RW	RW	RW	RW	RW	RW
Reset	0	0	0	0	0	0	0	0	0	0	0	0	0	0	0	0

Bit/Field	Name	Type	Reset	Description
31:0	DATA_IN	RW	0x0000.0000	Digest/Key Data

Register 36: SHA Revision (SHA_REVISION), offset 0x100

This register provides the unique revision number of the module. This can be used by the driver to determine the capabilities available.

SHA Revision (SHA_REVISION)

Base 0x4403.4000

Offset 0x100

Type RO, reset 0x40000C03

	31	30	29	28	27	26	25	24	23	22	21	20	19	18	17	16
	REVISION															
Type	RO	RO	RO	RO	RO	RO	RO	RO	RO	RO	RO	RO	RO	RO	RO	RO
Reset	0	1	0	0	0	0	0	0	0	0	0	0	0	0	0	0
	15	14	13	12	11	10	9	8	7	6	5	4	3	2	1	0
	REVISION															
Type	RO	RO	RO	RO	RO	RO	RO	RO	RO	RO	RO	RO	RO	RO	RO	RO
Reset	0	0	0	0	1	1	0	0	0	0	0	0	0	0	1	1

Bit/Field	Name	Type	Reset	Description
31:0	REVISION	RO	0x40000C03	Revision Number This field indicates the revision number of the module.

Register 37: SHA System Configuration (SHA_SYSCONFIG), offset 0x110

System configuration register

Note: After one operation has completed, the **SHA_SYSCONFIG** register must be cleared and re-configured for the next operation to ensure proper μ DMA and data operation functionality.

SHA System Configuration (SHA_SYSCONFIG)

Base 0x4403.4000
Offset 0x110
Type RW, reset 0x0000.0001

	31	30	29	28	27	26	25	24	23	22	21	20	19	18	17	16
	reserved															
Type	RO	RO	RO	RO	RO	RO	RO	RO	RO	RO	RO	RO	RO	RO	RO	RO
Reset	0	0	0	0	0	0	0	0	0	0	0	0	0	0	0	0
	15	14	13	12	11	10	9	8	7	6	5	4	3	2	1	0
	reserved								SADVANCED	reserved	SIDLE		DMA_EN	IT_EN	SOFTRESET	reserved
Type	RO	RO	RO	RO	RO	RO	RO	RO	RW	RO	RW	RW	RW	RW	RW	RO
Reset	0	0	0	0	0	0	0	0	0	0	0	0	0	0	0	1

Bit/Field	Name	Type	Reset	Description
31:8	reserved	RO	0	Software should not rely on the value of a reserved bit. To provide compatibility with future products, the value of a reserved bit should be preserved across a read-modify-write operation.
7	SADVANCED	RW	0	Advanced Mode Enable
				Value Description
			0	Legacy mode enabled for the Secure World. In Legacy mode, the Secure World, the context input DMA request, and the result output DMA request are masked. This means that neither DMAREQUEST_CTXIN_S and DMAREQUEST_CTXOUT_S are asserted.
			1	Advanced mode is enabled. These DMA requests are enabled by bit 3 of this register.
6	reserved	RO	0	Software should not rely on the value of a reserved bit. To provide compatibility with future products, the value of a reserved bit should be preserved across a read-modify-write operation.
5:4	SIDLE	RW	0	Side mode
				Value Description
			0x0	Force-idle mode
			0x1-0x3	reserved

Bit/Field	Name	Type	Reset	Description
3	DMA_EN	RW	0	<p>μDMA Request Enable</p> <p>This bit controls whether the μDMA interrupts can be programmed/controlled in the SHA_DMA_IM register.</p> <p>Note: If the μDMA is used for transferring data, then the IT_EN bit should be set to 0 and the SHA_IRQENABLE register should be clear.</p> <p>Value Description</p> <p>0 μDMA interrupts are disabled.</p> <p>1 μDMA interrupts are enabled.</p>
2	IT_EN	RW	0	<p>Interrupt Enable</p> <p>This bit controls whether the software interrupts can be programmed/controlled in the SHA_IRQENABLE register.</p> <p>Note: When enabling the interrupts in the SHA_IRQENABLE register, the application should poll these interrupts and configure a software interrupt in the μDMA to handle a trigger event.</p> <p>Value Description</p> <p>0 SHA software Interrupts are disabled.</p> <p>1 SHA software interrupts are enabled.</p>
1	SOFTRESET	RW	0	<p>Soft reset</p> <p>Value Description</p> <p>0 No operation</p> <p>1 Start soft reset sequence</p>
0	reserved	RO	1	<p>Software should not rely on the value of a reserved bit. To provide compatibility with future products, the value of a reserved bit should be preserved across a read-modify-write operation.</p>

Register 38: SHA System Status (SHA_SYSSTATUS), offset 0x114

System status register

SHA System Status (SHA_SYSSTATUS)

Base 0x4403.4000

Offset 0x114

Type RO, reset 0x0000.0001

	31	30	29	28	27	26	25	24	23	22	21	20	19	18	17	16
	reserved															
Type	RO	RO	RO	RO	RO	RO	RO	RO	RO	RO	RO	RO	RO	RO	RO	RO
Reset	0	0	0	0	0	0	0	0	0	0	0	0	0	0	0	0
	15	14	13	12	11	10	9	8	7	6	5	4	3	2	1	0
	reserved															RESETDONE
Type	RO	RO	RO	RO	RO	RO	RO	RO	RO	RO	RO	RO	RO	RO	RO	RO
Reset	0	0	0	0	0	0	0	0	0	0	0	0	0	0	0	1

Bit/Field	Name	Type	Reset	Description
31:1	reserved	RO	0	Software should not rely on the value of a reserved bit. To provide compatibility with future products, the value of a reserved bit should be preserved across a read-modify-write operation.
0	RESETDONE	RO	1	Reset done status
				Value Description
				0 Reset not complete
				1 Reset complete

Register 39: SHA Interrupt Status (SHA_IRQSTATUS), offset 0x118

Interrupt Status Register

SHA Interrupt Status (SHA_IRQSTATUS)

Base 0x4403.4000
 Offset 0x118
 Type RO, reset 0x0000.0008

	31	30	29	28	27	26	25	24	23	22	21	20	19	18	17	16
	reserved															
Type	RO	RO	RO	RO	RO	RO	RO	RO	RO	RO	RO	RO	RO	RO	RO	RO
Reset	0	0	0	0	0	0	0	0	0	0	0	0	0	0	0	0
	15	14	13	12	11	10	9	8	7	6	5	4	3	2	1	0
	reserved												CONTEXT_READY	reserved	INPUT_READY	OUTPUT_READY
Type	RO	RO	RO	RO	RO	RO	RO	RO	RO	RO	RO	RO	RO	RO	RO	RO
Reset	0	0	0	0	0	0	0	0	0	0	0	0	1	0	0	0

Bit/Field	Name	Type	Reset	Description
31:4	reserved	RO	0x0000.000	Software should not rely on the value of a reserved bit. To provide compatibility with future products, the value of a reserved bit should be preserved across a read-modify-write operation.
3	CONTEXT_READY	RO	1	Context Ready Status Value Description 0 The context registers are not available for a new context. 1 The context input registers are available for a new context for the next packet to be processed.
2	reserved	RO	0	Software should not rely on the value of a reserved bit. To provide compatibility with future products, the value of a reserved bit should be preserved across a read-modify-write operation.
1	INPUT_READY	RO	0	Input Ready Status Value Description 0 The Data FIFO is not ready to receive the next 64-byte data block. 1 The Data FIFO (SHA_DATA_n_IN registers) is ready to receive the next 64-byte data block.
0	OUTPUT_READY	RO	0	Output Ready Status Value Description 0 No saved context available. 1 A saved context is available from the context output registers.

Register 40: SHA Interrupt Enable (SHA_IRQENABLE), offset 0x11C

The **SHA_IRQENABLE** register contains an enable bit for each unique interrupt. An interrupt is enabled when both the global enable, the **IT_EN** bit, in the **SHA_SYSCONFIG** register and the bit in this register are both set to 1.

SHA Interrupt Enable (SHA_IRQENABLE)

Base 0x4403.4000
Offset 0x11C
Type RW, reset 0x0000.0007

	31	30	29	28	27	26	25	24	23	22	21	20	19	18	17	16	
	reserved																
Type	RO	RO	RO	RO	RO	RO	RO	RO	RO	RO	RO	RO	RO	RO	RO	RO	
Reset	0	0	0	0	0	0	0	0	0	0	0	0	0	0	0	0	
	15	14	13	12	11	10	9	8	7	6	5	4	3	2	1	0	
	reserved													M_CONTEXT_READY	reserved	M_INPUT_READY	M_OUTPUT_READY
Type	RO	RO	RO	RO	RO	RO	RO	RO	RO	RO	RO	RO	RO	RW	RO	RW	RW
Reset	0	0	0	0	0	0	0	0	0	0	0	0	0	0	0	1	1

Bit/Field	Name	Type	Reset	Description
31:4	reserved	RO	0x0000.000	Software should not rely on the value of a reserved bit. To provide compatibility with future products, the value of a reserved bit should be preserved across a read-modify-write operation.
3	M_CONTEXT_READY	RW	0	Mask for context ready interrupt Value Description 0 Context ready interrupt is disabled (masked). 1 Context ready interrupt is enabled.
2	reserved	RO	0	Software should not rely on the value of a reserved bit. To provide compatibility with future products, the value of a reserved bit should be preserved across a read-modify-write operation.
1	M_INPUT_READY	RW	1	Mask for input ready interrupt Value Description 0 Input ready interrupt is disabled (masked). 1 Input ready interrupt is enabled.
0	M_OUTPUT_READY	RW	1	Mask for output ready interrupt Value Description 0 Output ready interrupt is disabled (masked). 1 Output ready interrupt is enabled.

15.4 SHA/MD5 μ DMA Control Register Descriptions (Encryption Control Offset)

This section lists and describes the SHA/MD5 μ DMA registers, in numerical order by address offset. Registers in this section are relative to the Encryption Control base address of 0x4403.0000.

Note: The SHA module can only be accessed through privileged mode. If the μ DMA is used for SHA transfers, then the μ DMA's **DMA Channel Control (DMACHCTL)** register also needs to be programmed to allow for privileged accesses.

Note: If the application uses SHA μ DMA interrupt triggers, the bits in the **SHA_IRQENABLE** register should be cleared.

Register 41: SHA DMA Interrupt Mask (SHA_DMAIM), offset 0x010

The **SHA DMA Interrupt Mask (SHA_DMA_IM)** register controls interrupt behavior and are used to program which interrupts are suppressed.

SHA DMA Interrupt Mask (SHA_DMAIM)

Base
Offset 0x010
Type RW, reset 0x0000.0000

	31	30	29	28	27	26	25	24	23	22	21	20	19	18	17	16
	reserved															
Type	RO	RO	RO	RO	RO	RO	RO	RO	RO	RO	RO	RO	RO	RO	RO	RO
Reset	0	0	0	0	0	0	0	0	0	0	0	0	0	0	0	0
	15	14	13	12	11	10	9	8	7	6	5	4	3	2	1	0
	reserved													COUT	DIN	CIN
Type	RO	RO	RO	RO	RO	RO	RO	RO	RO	RO	RO	RO	RO	RW	RW	RW
Reset	0	0	0	0	0	0	0	0	0	0	0	0	0	0	0	0

Bit/Field	Name	Type	Reset	Description
31:3	reserved	RO	0x0000.000	Software should not rely on the value of a reserved bit. To provide compatibility with future products, the value of a reserved bit should be preserved across a read-modify-write operation.
2	COUT	RW	0	Context Out DMA Done Interrupt Mask If this bit is unmasked, an interrupt is generated when the μ DMA completes the output context read from the internal register. Value Description 0 The COUT interrupt is suppressed and not sent to the interrupt controller. 1 The COUT interrupt is sent to the interrupt controller.
1	DIN	RW	0	Data In DMA Done Interrupt Mask If this bit is unmasked, an interrupt is generated when the μ DMA writes the last word of input data to the internal FIFO of the engine. Value Description 0 The DIN interrupt is suppressed and not sent to the interrupt controller. 1 The DIN interrupt is sent to the interrupt controller.
0	CIN	RW	0	Context In DMA Done Interrupt Mask If this bit is unmasked, an interrupt is generated when the μ DMA completes a context write to the internal register. Value Description 0 The CIN interrupt is suppressed and not sent to the interrupt controller. 1 The CIN interrupt is sent to the interrupt controller.

Register 42: SHA DMA Raw Interrupt Status (SHA_DMARIS), offset 0x014

The **SHA DMA Raw Interrupt Status (SHA_DMA_RIS)** register contains the raw interrupt status. If any of these bits read 1, the processor is interrupted if the corresponding masked interrupt status bit is set to '1.'

SHA DMA Raw Interrupt Status (SHA_DMARIS)

Base
Offset 0x014
Type RO, reset 0x0000.0000

	31	30	29	28	27	26	25	24	23	22	21	20	19	18	17	16	
	reserved																
Type	RO	RO	RO	RO	RO	RO	RO	RO	RO	RO	RO	RO	RO	RO	RO	RO	
Reset	0	0	0	0	0	0	0	0	0	0	0	0	0	0	0	0	
	15	14	13	12	11	10	9	8	7	6	5	4	3	2	1	0	
	reserved													COUT	DIN	CIN	
Type	RO	RO	RO	RO	RO	RO	RO	RO	RO	RO	RO	RO	RO	RO	RW	RW	RW
Reset	0	0	0	0	0	0	0	0	0	0	0	0	0	0	0	0	0

Bit/Field	Name	Type	Reset	Description
31:3	reserved	RO	0x0000.000	Software should not rely on the value of a reserved bit. To provide compatibility with future products, the value of a reserved bit should be preserved across a read-modify-write operation.
2	COUT	RW	0	Context Out DMA Done Raw Interrupt Status Value Description 0 No Interrupt. 1 The μ DMA has completed the output context read from the internal register and an interrupt has been triggered and is pending.
1	DIN	RW	0	Data In DMA Done Raw Interrupt Status Value Description 0 No Interrupt. 1 The μ DMA has written the last word of input data to the internal FIFO of the engine and an interrupt has been triggered and is pending.
0	CIN	RW	0	Context In DMA Done Raw Interrupt Status Value Description 0 No interrupt. 1 The μ DMA has completed a context write to the internal register and an interrupt has been triggered and is pending.

Register 43: SHA DMA Masked Interrupt Status (SHA_DMAMIS), offset 0x018

The **SHA DMA Masked Interrupt Status (SHA_DMA_MIS)** register displays the raw interrupts that are unmasked in the **SHA_DMA_RIS** register.

SHA DMA Masked Interrupt Status (SHA_DMAMIS)

Base
Offset 0x018
Type RO, reset 0x0000.0000

	31	30	29	28	27	26	25	24	23	22	21	20	19	18	17	16
	reserved															
Type	RO	RO	RO	RO	RO	RO	RO	RO	RO	RO	RO	RO	RO	RO	RO	RO
Reset	0	0	0	0	0	0	0	0	0	0	0	0	0	0	0	0
	15	14	13	12	11	10	9	8	7	6	5	4	3	2	1	0
	reserved													COUT	DIN	CIN
Type	RO	RO	RO	RO	RO	RO	RO	RO	RO	RO	RO	RO	RO	RO	RO	RO
Reset	0	0	0	0	0	0	0	0	0	0	0	0	0	0	0	0

Bit/Field	Name	Type	Reset	Description
31:3	reserved	RO	0x0000.000	Software should not rely on the value of a reserved bit. To provide compatibility with future products, the value of a reserved bit should be preserved across a read-modify-write operation.
2	COUT	RO	0	Context Out DMA Done Masked Interrupt Status Value Description 0 An interrupt has not occurred or is masked. 1 A COUT interrupt has occurred.
1	DIN	RO	0	Data In DMA Done Masked Interrupt Status Value Description 0 An interrupt has not occurred or is masked. 1 A DIN interrupt has occurred.
0	CIN	RO	0	Context In DMA Done Raw Interrupt Status Value Description 0 An interrupt has not occurred or is masked. 1 A CIN interrupt has occurred.

Register 44: SHA DMA Interrupt Clear (SHA_DMAIC), offset 0x01C

The **SHA DMA Interrupt Clear** register is used to clear the **SHA_DMA_RIS** and **SHA_DMA_MIS** registers by writing a 1 to each register bit.

Note: This registers always reads as zero.

SHA DMA Interrupt Clear (SHA_DMAIC)

Base

Offset 0x01C

Type W1C, reset 0x0000.0000

	31	30	29	28	27	26	25	24	23	22	21	20	19	18	17	16	
	reserved																
Type	RO	RO	RO	RO	RO	RO	RO	RO	RO	RO	RO	RO	RO	RO	RO	RO	
Reset	0	0	0	0	0	0	0	0	0	0	0	0	0	0	0	0	
	15	14	13	12	11	10	9	8	7	6	5	4	3	2	1	0	
	reserved													COUT	DIN	CIN	
Type	RO	RO	RO	RO	RO	RO	RO	RO	RO	RO	RO	RO	RO	RO	W1C	W1C	W1C
Reset	0	0	0	0	0	0	0	0	0	0	0	0	0	0	0	0	0

Bit/Field	Name	Type	Reset	Description
31:3	reserved	RO	0x0000.000	Software should not rely on the value of a reserved bit. To provide compatibility with future products, the value of a reserved bit should be preserved across a read-modify-write operation.
2	COUT	W1C	0	Context Out DMA Done Masked Interrupt Status Writing a 1 to this bit clears the COUT bit in the SHA_DMA_RIS and SHA_DMA_MIS register.
1	DIN	W1C	0	Data In DMA Done Interrupt Clear Writing a 1 to this bit clears the DIN bit in the SHA_DMA_RIS and SHA_DMA_MIS register.
0	CIN	W1C	0	Context In DMA Done Raw Interrupt Status Writing a 1 to this bit clears the CIN bit in the SHA_DMA_RIS and SHA_DMA_MIS register..

16 General-Purpose Timers

Programmable timers can be used to count or time external events that drive the Timer input pins. The TM4C129ENCPDT General-Purpose Timer Module (GPTM) contains 16/32-bit GPTM blocks. Each 16/32-bit GPTM block provides two 16-bit timers/counters (referred to as Timer A and Timer B) that can be configured to operate independently as timers or event counters, or concatenated to operate as one 32-bit timer or one 32-bit Real-Time Clock (RTC). Timers can also be used to trigger μ DMA transfers.

In addition, timers can be used to trigger analog-to-digital conversions (ADC). The ADC trigger signals from all of the general-purpose timers are ORed together before reaching the ADC module, so only one timer should be used to trigger ADC events.

The GPT Module is one timing resource available on the Tiva™ C Series microcontrollers. Other timer resources include the System Timer (SysTick) (see 142) and the PWM timer in the PWM module (see “PWM Timer” on page 1796).

The General-Purpose Timer Module (GPTM) contains eight 16/32-bit GPTM blocks with the following functional options:

- Operating modes:
 - 16- or 32-bit programmable one-shot timer
 - 16- or 32-bit programmable periodic timer
 - 16-bit general-purpose timer with an 8-bit prescaler
 - 32-bit Real-Time Clock (RTC) when using an external 32.768-KHz clock as the input
 - 16-bit input-edge count- or time-capture modes with an 8-bit prescaler
 - 16-bit PWM mode with an 8-bit prescaler and software-programmable output inversion of the PWM signal
 - The System Clock or a global Alternate Clock (ALTCLK) resource can be used as timer clock source. The global ALTCLK can be:
 - PIOSC
 - Hibernation Module Real-time clock output (RTCOSC)
 - Low-frequency internal oscillator (LFIOSC)
- Count up or down
- Twelve 16/32-bit Capture Compare PWM pins (CCP)
- Daisy chaining of timer modules to allow a single timer to initiate multiple timing events
- Timer synchronization allows selected timers to start counting on the same clock cycle
- ADC event trigger
- User-enabled stalling when the microcontroller asserts CPU Halt flag during debug (excluding RTC mode)

- Ability to determine the elapsed time between the assertion of the timer interrupt and entry into the interrupt service routine
- Efficient transfers using Micro Direct Memory Access Controller (μ DMA)
 - Dedicated channel for each timer
 - Burst request generated on timer interrupt

16.1 Block Diagram

In the block diagram, the specific Capture Compare PWM (CCP) pins available depend on the TM4C129ENCPDT device. See Table 16-1 on page 1080 for the available CCP pins and their timer assignments.

Figure 16-1. GPTM Module Block Diagram

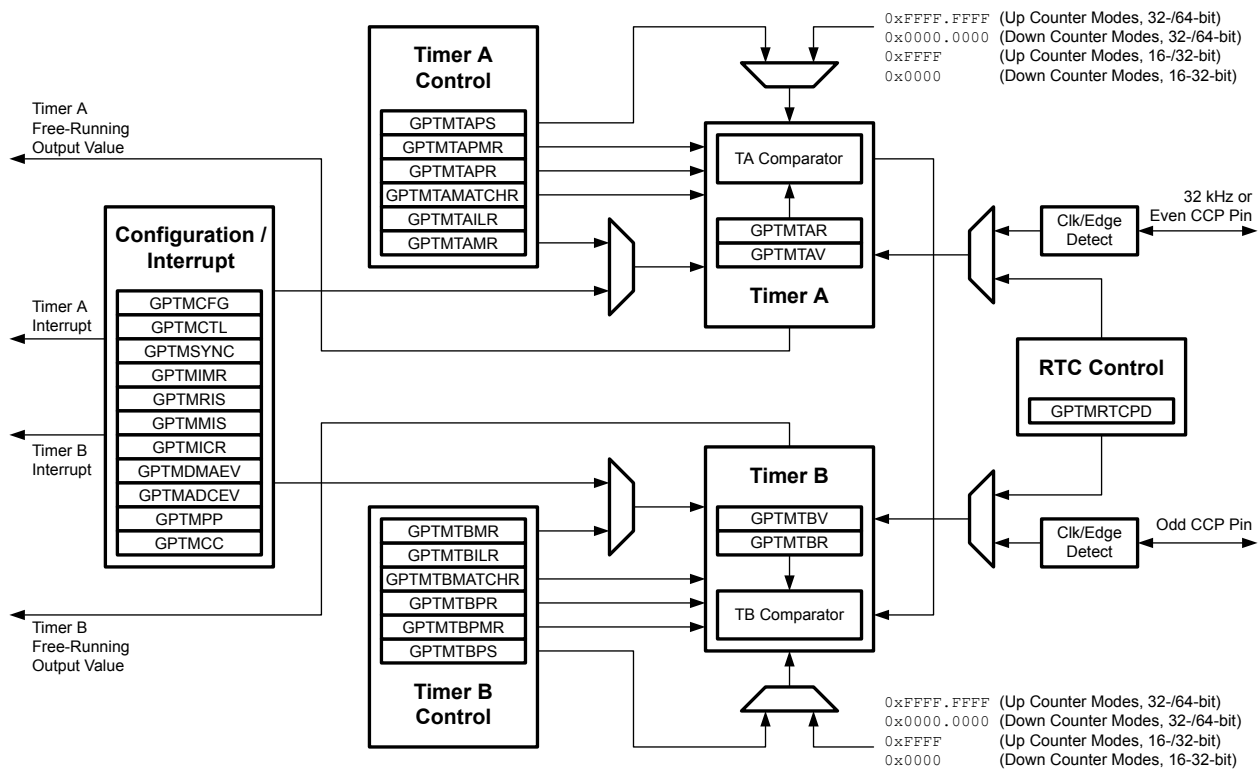

Table 16-1. Available CCP Pins

Timer	Up/Down Counter	Even CCP Pin	Odd CCP Pin
16/32-Bit Timer 0	Timer A	T0CCP0	-
	Timer B	-	T0CCP1
16/32-Bit Timer 1	Timer A	T1CCP0	-
	Timer B	-	T1CCP1
16/32-Bit Timer 2	Timer A	T2CCP0	-
	Timer B	-	T2CCP1

Table 16-1. Available CCP Pins (continued)

Timer	Up/Down Counter	Even CCP Pin	Odd CCP Pin
16/32-Bit Timer 3	Timer A	T3CCP0	-
	Timer B	-	T3CCP1
16/32-Bit Timer 4	Timer A	T4CCP0	-
	Timer B	-	T4CCP1
16/32-Bit Timer 5	Timer A	T5CCP0	-
	Timer B	-	T5CCP1
16/32-Bit Timer 6	Timer A	T6CCP0	-
	Timer B	-	T6CCP1
16/32-Bit Timer 7	Timer A	T7CCP0	-
	Timer B	-	T7CCP1

16.2 Signal Description

The following table lists the external signals of the GP Timer module and describes the function of each. The GP Timer signals are alternate functions for some GPIO signals and default to be GPIO signals at reset. The column in the table below titled "Pin Mux/Pin Assignment" lists the possible GPIO pin placements for these GP Timer signals. The `AFSEL` bit in the **GPIO Alternate Function Select (GPIOAFSEL)** register (page 778) should be set to choose the GP Timer function. The number in parentheses is the encoding that must be programmed into the `PMCn` field in the **GPIO Port Control (GPIOCTL)** register (page 795) to assign the GP Timer signal to the specified GPIO port pin. For more information on configuring GPIOs, see "General-Purpose Input/Outputs (GPIOs)" on page 750.

Table 16-2. General-Purpose Timers Signals (128TQFP)

Pin Name	Pin Number	Pin Mux / Pin Assignment	Pin Type	Buffer Type	Description
T0CCP0	1	PD0 (3)	I/O	TTL	16/32-Bit Timer 0 Capture/Compare/PWM 0.
	33	PA0 (3)			
	85	PL4 (3)			
T0CCP1	2	PD1 (3)	I/O	TTL	16/32-Bit Timer 0 Capture/Compare/PWM 1.
	34	PA1 (3)			
	86	PL5 (3)			
T1CCP0	3	PD2 (3)	I/O	TTL	16/32-Bit Timer 1 Capture/Compare/PWM 0.
	35	PA2 (3)			
	94	PL6 (3)			
T1CCP1	4	PD3 (3)	I/O	TTL	16/32-Bit Timer 1 Capture/Compare/PWM 1.
	36	PA3 (3)			
	93	PL7 (3)			
T2CCP0	37	PA4 (3)	I/O	TTL	16/32-Bit Timer 2 Capture/Compare/PWM 0.
	78	PM0 (3)			
T2CCP1	38	PA5 (3)	I/O	TTL	16/32-Bit Timer 2 Capture/Compare/PWM 1.
	77	PM1 (3)			
T3CCP0	40	PA6 (3)	I/O	TTL	16/32-Bit Timer 3 Capture/Compare/PWM 0.
	76	PM2 (3)			
	125	PD4 (3)			
T3CCP1	41	PA7 (3)	I/O	TTL	16/32-Bit Timer 3 Capture/Compare/PWM 1.
	75	PM3 (3)			
	126	PD5 (3)			

Table 16-2. General-Purpose Timers Signals (128TQFP) (continued)

Pin Name	Pin Number	Pin Mux / Pin Assignment	Pin Type	Buffer Type	Description
T4CCP0	74 95 127	PM4 (3) PB0 (3) PD6 (3)	I/O	TTL	16/32-Bit Timer 4 Capture/Compare/PWM 0.
T4CCP1	73 96 128	PM5 (3) PB1 (3) PD7 (3)	I/O	TTL	16/32-Bit Timer 4 Capture/Compare/PWM 1.
T5CCP0	72 91	PM6 (3) PB2 (3)	I/O	TTL	16/32-Bit Timer 5 Capture/Compare/PWM 0.
T5CCP1	71 92	PM7 (3) PB3 (3)	I/O	TTL	16/32-Bit Timer 5 Capture/Compare/PWM 1.

16.3 Functional Description

The main components of each GPTM block are two free-running up/down counters (referred to as Timer A and Timer B), two prescaler registers, two match registers, two prescaler match registers, two shadow registers, and two load/initialization registers and their associated control functions. The exact functionality of each GPTM is controlled by software and configured through the register interface. Timer A and Timer B can be used individually, in which case they have a 16-bit counting range for the 16/32-bit GPTM blocks. In addition, Timer A and Timer B can be concatenated to provide a 32-bit counting range for the 16/32-bit GPTM blocks. Note that the prescaler can only be used when the timers are used individually.

The available modes for each GPTM block are shown in Table 16-3 on page 1082. Note that when counting down in one-shot or periodic modes, the prescaler acts as a true prescaler and contains the least-significant bits of the count. When counting up in one-shot or periodic modes, the prescaler acts as a timer extension and holds the most-significant bits of the count. In input edge count, input edge time and PWM mode, the prescaler always acts as a timer extension, regardless of the count direction.

Table 16-3. General-Purpose Timer Capabilities

Mode	Timer Use	Count Direction	Counter Size	Prescaler Size ^a
One-shot	Individual	Up or Down	16-bit	8-bit
	Concatenated	Up or Down	32-bit	-
Periodic	Individual	Up or Down	16-bit	8-bit
	Concatenated	Up or Down	32-bit	-
RTC	Concatenated	Up	32-bit	-
Edge Count	Individual	Up or Down	16-bit	8-bit
Edge Time	Individual	Up or Down	16-bit	8-bit
PWM	Individual	Down	16-bit	8-bit

a. The prescaler is only available when the timers are used individually

Software configures the GPTM using the **GPTM Configuration (GPTMCFG)** register (see page 1100), the **GPTM Timer A Mode (GPTMTAMR)** register (see page 1101), and the **GPTM Timer B Mode (GPTMTBMR)** register (see page 1106). When in one of the concatenated modes, Timer A and Timer B can only operate in one mode. However, when configured in an individual mode, Timer A and Timer B can be independently configured in any combination of the individual modes.

16.3.1 GPTM Reset Conditions

After reset has been applied to the GPTM module, the module is in an inactive state, and all control registers are cleared and in their default states. Counters Timer A and Timer B are initialized to all 1s, along with their corresponding registers:

- Load Registers:
 - **GPTM Timer A Interval Load (GPTMTAILR)** register (see page 1128)
 - **GPTM Timer B Interval Load (GPTMTBILR)** register (see page 1129)
- Shadow Registers:
 - **GPTM Timer A Value (GPTMTAV)** register (see page 1138)
 - **GPTM Timer B Value (GPTMTBV)** register (see page 1139)

The following prescale counters are initialized to all 0s:

- **GPTM Timer A Prescale (GPTMTAPR)** register (see page 1132)
- **GPTM Timer B Prescale (GPTMTBPR)** register (see page 1133)
- **GPTM Timer A Prescale Snapshot (GPTMTAPS)** register (see page 1141)
- **GPTM Timer B Prescale Snapshot (GPTMTBPS)** register (see page 1142)

16.3.2 Timer Clock Source

The general purpose timer has the capability of being clocked by either the system clock or an alternate clock source. By setting the `ALTCLK` bit in the **GPTM Clock Configuration (GPTMCC)** register, offset 0xFC8, software can select an alternate clock source as programmed in the **Alternate Clock Configuration (ALTCLKCFG)** register, offset 0x138 in the System Control Module. The alternate clock source options available are `PIOSC`, `RTCOSC` and `LFIOOSC`. Refer to “System Control” on page 227 for additional information.

Note: When the `ALTCLK` bit is set in the **GPTMCC** register to enable using the alternate clock source, the synchronization imposes restrictions on the starting count value (down-count), terminal value (up-count) and the match value. This restriction applies to all modes of operation. Each event must be spaced by 4 Timer (`ALTCLK`) clock periods + 2 system clock periods. If some events do not meet this requirement, then it is possible that the timer block may need to be reset for correct functionality to be restored.

Example: $ALTCLK = T_{PIOSC} = 62.5\text{ns}$ (16Mhz Trimmed)

$T_{hclk} = 1\mu\text{s}$ (1Mhz)

$4 * 62.5\text{ns} + 2 * 1\mu\text{s} = 2.25\mu\text{s}$ $2.25\mu\text{s} / 62.5\text{ns} = 36$ or 0x23

The minimum values for the periodic or one-shot with a match interrupt enabled are:

GPTMTAMATCHR = 0x23 **GPTMTAILR** = 0x46

16.3.3 Timer Modes

This section describes the operation of the various timer modes. When using Timer A and Timer B in concatenated mode, only the Timer A control and status bits must be used; there is no need to use Timer B control and status bits. The GPTM is placed into individual/split mode by writing a value

of 0x4 to the **GPTM Configuration (GPTMCFG)** register (see page 1100). In the following sections, the variable "n" is used in bit field and register names to imply either a Timer A function or a Timer B function. Throughout this section, the timeout event in down-count mode is 0x0 and in up-count mode is the value in the **GPTM Timer n Interval Load (GPTMTnILR)** and the optional **GPTM Timer n Prescale (GPTMTnPR)** registers, with the exception of RTC mode.

16.3.3.1 One-Shot/Periodic Timer Mode

The selection of one-shot or periodic mode is determined by the value written to the T_nMR field of the **GPTM Timer n Mode (GPTMTnMR)** register (see page 1101). The timer is configured to count up or down using the T_nCDIR bit in the **GPTMTnMR** register.

When software sets the T_nEN bit in the **GPTM Control (GPTMCTL)** register (see page 1110), the timer begins counting up from 0x0 or down from its preloaded value. Alternatively, if the T_nWOT bit is set in the **GPTMTnMR** register, once the T_nEN bit is set, the timer waits for a trigger to begin counting (see "Wait-for-Trigger Mode" on page 1092). Table 16-4 on page 1084 shows the values that are loaded into the timer registers when the timer is enabled.

Table 16-4. Counter Values When the Timer is Enabled in Periodic or One-Shot Modes

Register	Count Down Mode	Count Up Mode
GPTMTnR	GPTMTnILR	0x0
GPTMTnV	GPTMTnILR in concatenated mode; GPTMTnPR in combination with GPTMTnILR in individual mode	0x0
GPTMTnPS	GPTMTnPR in individual mode; not available in concatenated mode	0x0 in individual mode; not available in concatenated mode

When the timer is counting down and it reaches the timeout event (0x0), the timer reloads its start value from the **GPTMTnILR** and the **GPTMTnPR** registers on the next cycle. When the timer is counting up and it reaches the timeout event (the value in the **GPTMTnILR** and the optional **GPTMTnPR** registers), the timer reloads with 0x0. If configured to be a one-shot timer, the timer stops counting and clears the T_nEN bit in the **GPTMCTL** register. If configured as a periodic timer, the timer starts counting again on the next cycle.

In periodic, snap-shot mode (T_nMR field is 0x2 and the T_nSNAPS bit is set in the **GPTMTnMR** register), the value of the timer at the time-out event is loaded into the **GPTMTnR** register and the value of the prescaler is loaded into the **GPTMTnPS** register. The free-running counter value is shown in the **GPTMTnV** register. In this manner, software can determine the time elapsed from the interrupt assertion to the ISR entry by examining the snapshot values and the current value of the free-running timer. Snapshot mode is not available when the timer is configured in one-shot mode.

In addition to reloading the count value, the GPTM can generate interrupts, CCP outputs and triggers when it reaches the time-out event. The GPTM sets the T_nTORIS bit in the **GPTM Raw Interrupt Status (GPTMRIS)** register (see page 1120), and holds it until it is cleared by writing the **GPTM Interrupt Clear (GPTMICR)** register (see page 1126). If the time-out interrupt is enabled in the **GPTM Interrupt Mask (GPTMIMR)** register (see page 1117), the GPTM also sets the T_nTOMIS bit in the **GPTM Masked Interrupt Status (GPTMMIS)** register (see page 1123). The time-out interrupt can be disabled entirely by setting the T_nCINTD bit in the **GPTM Timer n Mode (GPTMTnMR)** register. In this case, the T_nTORIS bit does not even set in the **GPTMRIS** register.

By setting the T_nMIE bit in the **GPTMTnMR** register, an interrupt condition can also be generated when the Timer value equals the value loaded into the **GPTM Timer n Match (GPTMTnMATCHR)** and **GPTM Timer n Prescale Match (GPTMTnPMR)** registers. This interrupt has the same status, masking, and clearing functions as the time-out interrupt, but uses the match interrupt bits instead (for example, the raw interrupt status is monitored via T_nMRIS bit in the **GPTM Raw Interrupt Status**

(**GPTMRIS**) register). Note that the interrupt status bits are not updated by the hardware unless the **TnMIE** bit in the **GPTMTnMR** register is set, which is different than the behavior for the time-out interrupt. The ADC trigger is enabled by setting the **TnOTE** bit in **GPTMCTL** and the event that activates the ADC is configured in the **GPTM ADC Event (GPTMADCEV)** register. The μ DMA trigger is enabled by configuring and enabling the appropriate μ DMA channel as well as the type of trigger enable in the **GPTM DMA Event (GPTMDMAEV)** register. See “Channel Configuration” on page 691.

The **TCACT** field of the **GPTM Timer n Mode (GPTMTnMR)** register can be configured to clear, set or toggle an output on a time-out event.

If software updates the **GPTMTnILR** or the **GPTMTnPR** register while the counter is counting down, the counter loads the new value on the next clock cycle and continues counting from the new value if the **TnILD** bit in the **GPTMTnMR** register is clear. If the **TnILD** bit is set, the counter loads the new value after the next timeout. If software updates the **GPTMTnILR** or the **GPTMTnPR** register while the counter is counting up, the timeout event is changed on the next cycle to the new value. If software updates the **GPTM Timer n Value (GPTMTnV)** register while the counter is counting up or down, the counter loads the new value on the next clock cycle and continues counting from the new value. If software updates the **GPTMTnMATCHR** or the **GPTMTnPMR** registers, the new values are reflected on the next clock cycle if the **TnMRSU** bit in the **GPTMTnMR** register is clear. If the **TnMRSU** bit is set, the new value will not take effect until the next timeout.

If the **TnSTALL** bit in the **GPTMCTL** register is set and the **RTCEN** bit is not set in the **GPTMCTL** register, the timer freezes counting while the processor is halted by the debugger. The timer resumes counting when the processor resumes execution. If the **RTCEN** bit is set, it prevents the **TnSTALL** bit from freezing the count when the processor is halted by the debugger.

The following table shows a variety of configurations for a 16-bit free-running timer while using the prescaler. All values assume a 120-MHz clock with $T_c=8.33$ ns (clock period). The prescaler can only be used when a 16/32-bit timer is configured in 16-bit mode.

Table 16-5. 16-Bit Timer With Prescaler Configurations

Prescale (8-bit value)	# of Timer Clocks (T_c) ^a	Max Time	Units
00000000	1	0.548258	ms
00000001	2	1.096517	ms
00000010	3	1.644775	ms
-----	--	--	--
11111101	254	139.2576	ms
11111110	255	139.8059	ms
11111111	256	140.3541	ms

a. T_c is the clock period.

Timer Compare Action Mode

The timer compare mode is an extension to the GPTM's existing one-shot and periodic modes. This mode can be used when an application requires a pin change state at some time in the future, regardless of the processor state. The compare mode does not operate when the PWM mode is active and is mutually exclusive to the PWM mode. The compare mode is enabled when the **TAMR** field is set to 0x1 or 0x2 (one-shot or periodic), the **TnAMS** bit is 0 (capture or compare mode) and the **TCACT** field is nonzero in the **GPTM Timer n Mode (GPTMTnMR)** register. Depending on the **TCACT** encoding, the timer can perform a set, clear or toggle on the corresponding CCPn pin when a timer match occurs. In 16-bit mode, the corresponding CCP pin can have an action applied, but when operating in 32-bit mode, the action can only be applied to the even CCP pin.

The **TCACT** field can be changed while the GPTM is enabled to generate different combinations of actions. For example, during a periodic event, encodings **TCACT** = 0x6 or 0x7 can be used to force the initial state of the **CCP_n** pin before the first interrupt and following that, **TCACT**=0x2 and **TCACT**=0x3 can be used (alternately) to change the sense of the pin for the subsequent toggle, while possible changing load value for the next period.

The time-out interrupts used for one-shot and periodic modes are used in the compare action modes. Thus, the **T_nTORIS** bits in the **GPTMRIS** register are triggered if the appropriate mask bits are set in the **GPTMIM** register.

16.3.3.2 Real-Time Clock Timer Mode

In Real-Time Clock (RTC) mode, the concatenated versions of the Timer A and Timer B registers are configured as an up-counter. When RTC mode is selected for the first time after reset, the counter is loaded with a value of 0x1. All subsequent load values must be written to the **GPTM Timer n Interval Load (GPTMTnILR)** registers (see page 1128). If the **GPTMTnILR** register is loaded with a new value, the counter begins counting at that value and rolls over at the fixed value of 0xFFFFFFFF. Table 16-6 on page 1086 shows the values that are loaded into the timer registers when the timer is enabled.

Table 16-6. Counter Values When the Timer is Enabled in RTC Mode

Register	Count Down Mode	Count Up Mode
GPTMTnR	Not available	0x1
GPTMTnV	Not available	0x1
GPTMTnPS	Not available	Not available

The input clock on a **CCP0** input is required to be 32.768 KHz in RTC mode. The clock signal is then divided down to a 1-Hz rate and is passed along to the input of the counter.

When software writes the **TAEN** bit in the **GPTMCTL** register, the counter starts counting up from its preloaded value of 0x1. When the current count value matches the preloaded value in the **GPTMTnMATCHR** registers, the GPTM asserts the **RTC_{RIS}** bit in **GPTMRIS** and continues counting until either a hardware reset, or it is disabled by software (clearing the **TAEN** bit). When the timer value reaches the terminal count, the timer rolls over and continues counting up from 0x0. If the RTC interrupt is enabled in **GPTMIMR**, the GPTM also sets the **RTC_{MIS}** bit in **GPTMMIS** and generates a controller interrupt. The status flags are cleared by writing the **RTC_{CINT}** bit in **GPTMICR**.

In this mode, the **GPTMTnR** and **GPTMTnV** registers always have the same value.

In addition to generating interrupts, the RTC can generate a μ DMA trigger. The μ DMA trigger is enabled by configuring and enabling the appropriate μ DMA channel as well as the type of trigger enable in the **GPTM DMA Event (GPTMDMAEV)** register. See “Channel Configuration” on page 691.

16.3.3.3 Input Edge-Count Mode

Note: For rising-edge detection, the input signal must be High for at least two clock periods following the rising edge. Similarly, for falling-edge detection, the input signal must be Low for at least two clock periods following the falling edge. Based on this criteria, the maximum input frequency for edge detection is 1/4 of the frequency.

In Edge-Count mode, the timer is configured as a 24-bit up- or down-counter including the optional prescaler with the upper count value stored in the **GPTM Timer n Prescale (GPTMTnPR)** register and the lower bits in the **GPTMTnR** register. In this mode, the timer is capable of capturing three types of events: rising edge, falling edge, or both. To place the timer in Edge-Count mode, the **T_nCMR** bit of the **GPTMTnMR** register must be cleared. The type of edge that the timer counts is

determined by the $TnEVENT$ fields of the **GPTMCTL** register. During initialization in down-count mode, the **GPTMTnMATCHR** and **GPTMTnPMR** registers are configured so that the difference between the value in the **GPTMTnILR** and **GPTMTnPR** registers and the **GPTMTnMATCHR** and **GPTMTnPMR** registers equals the number of edge events that must be counted. In up-count mode, the timer counts from 0x0 to the value in the **GPTMTnMATCHR** and **GPTMTnPMR** registers. Note that when executing an up-count, that the value of **GPTMTnPR** and **GPTMTnILR** must be greater than the value of **GPTMTnPMR** and **GPTMTnMATCHR**. Table 16-7 on page 1087 shows the values that are loaded into the timer registers when the timer is enabled.

Table 16-7. Counter Values When the Timer is Enabled in Input Edge-Count Mode

Register	Count Down Mode	Count Up Mode
GPTMTnR	GPTMTnPR in combination with GPTMTnILR	0x0
GPTMTnV	GPTMTnPR in combination with GPTMTnILR	0x0

When software writes the $TnEN$ bit in the **GPTM Control (GPTMCTL)** register, the timer is enabled for event capture. Each input event on the CCP pin decrements or increments the counter by 1 until the event count matches **GPTMTnMATCHR** and **GPTMTnPMR**. When the counts match, the GPTM asserts the $CnMRIS$ bit in the **GPTM Raw Interrupt Status (GPTMRIS)** register, and holds it until it is cleared by writing the **GPTM Interrupt Clear (GPTMICR)** register. If the capture mode match interrupt is enabled in the **GPTM Interrupt Mask (GPTMIMR)** register, the GPTM also sets the $CnMMIS$ bit in the **GPTM Masked Interrupt Status (GPTMMIS)** register. In up-count mode, the current count of the input events is held in both the **GPTMTnR** and **GPTMTnV** registers. In down-count mode, the current count of the input events can be obtained by subtracting the **GPTMTnR** or **GPTMTnV** from the value made up of the **GPTMTnPR** and **GPTMTnILR** register combination.

In addition to generating interrupts, an ADC and/or a μ DMA trigger can be generated. The ADC trigger is enabled by setting the $TnOTE$ bit in **GPTMCTL** and the event that activates the ADC is configured in the **GPTM ADC Event (GPTMADCEV)** register. The μ DMA trigger is enabled by configuring and enabling the appropriate μ DMA channel as well as the type of trigger enable in the **GPTM DMA Event (GPTMDMAEV)** register. See “Channel Configuration” on page 691.

After the match value is reached in down-count mode, the counter is then reloaded using the value in **GPTMTnILR** and **GPTMTnPR** registers, and stopped because the GPTM automatically clears the $TnEN$ bit in the **GPTMCTL** register. Once the event count has been reached, all further events are ignored until $TnEN$ is re-enabled by software. In up-count mode, the timer is reloaded with 0x0 and continues counting.

Figure 16-2 on page 1088 shows how Input Edge-Count mode works. In this case, the timer start value is set to **GPTMTnILR** = 0x000A and the match value is set to **GPTMTnMATCHR** = 0x0006 so that four edge events are counted. The counter is configured to detect both edges of the input signal.

Note that the last two edges are not counted because the timer automatically clears the $TnEN$ bit after the current count matches the value in the **GPTMTnMATCHR** register.

Figure 16-2. Input Edge-Count Mode Example, Counting Down



16.3.3.4 Input Edge-Time Mode

Note: For rising-edge detection, the input signal must be High for at least two system clock periods following the rising edge. Similarly, for falling edge detection, the input signal must be Low for at least two system clock periods following the falling edge. Based on this criteria, the maximum input frequency for edge detection is 1/4 of the system frequency.

In Edge-Time mode, the timer is configured as a 24-bit up- or down-counter including the optional prescaler with the upper timer value stored in the **GPTMTnPR** register and the lower bits in the **GPTMTnILR** register. In this mode, the timer is initialized to the value loaded in the **GPTMTnILR** and **GPTMTnPR** registers when counting down and 0x0 when counting up. The timer is capable of capturing three types of events: rising edge, falling edge, or both. The timer is placed into Edge-Time mode by setting the **TnCMR** bit in the **GPTMTnMR** register, and the type of event that the timer captures is determined by the **TnEVENT** fields of the **GPTMCTL** register. Table 16-8 on page 1088 shows the values that are loaded into the timer registers when the timer is enabled.

Table 16-8. Counter Values When the Timer is Enabled in Input Event-Count Mode

Register	Count Down Mode	Count Up Mode
TnR	GPTMTnILR	0x0
TnV	GPTMTnILR	0x0

When software writes the **TnEN** bit in the **GPTMCTL** register, the timer is enabled for event capture. When the selected input event is detected, the current timer counter value is captured in the **GPTMTnR** and **GPTMTnPS** register and is available to be read by the microcontroller. The GPTM then asserts the **CnERIS** bit in the **GPTM Raw Interrupt Status (GPTMRIS)** register, and holds it until it is cleared by writing the **GPTM Interrupt Clear (GPTMICR)** register. If the capture mode event interrupt is enabled in the **GPTM Interrupt Mask (GPTMIMR)** register, the GPTM also sets the **CnEMIS** bit in the **GPTM Masked Interrupt Status (GPTMMIS)** register. In this mode, the **GPTMTnR** and **GPTMTnPS** registers hold the time at which the selected input event occurred while

the **GPTMTnV** register holds the free-running timer value. These registers can be read to determine the time that elapsed between the interrupt assertion and the entry into the ISR.

In addition to generating interrupts, an ADC and/or a μ DMA trigger can be generated. The ADC trigger is enabled by setting the **TnOTE** bit in **GPTMCTL** and the event that activates the ADC is configured in the **GPTM ADC Event (GPTMADCEV)** register. The μ DMA trigger is enabled by configuring the appropriate μ DMA channel as well as the type of trigger selected in the **GPTM DMA Event (GPTMDMAEV)** register. See “Channel Configuration” on page 691.

After an event has been captured, the timer does not stop counting. It continues to count until the **TnEN** bit is cleared. When the timer reaches the timeout value, it is reloaded with 0x0 in up-count mode and the value from the **GPTMTnILR** and **GPTMTnPR** registers in down-count mode.

Figure 16-3 on page 1089 shows how input edge timing mode works. In the diagram, it is assumed that the start value of the timer is the default value of 0xFFFF, and the timer is configured to capture rising edge events.

Each time a rising edge event is detected, the current count value is loaded into the **GPTMTnR** and **GPTMTnPS** registers, and is held there until another rising edge is detected (at which point the new count value is loaded into the **GPTMTnR** and **GPTMTnPS** registers).

Figure 16-3. 16-Bit Input Edge-Time Mode Example

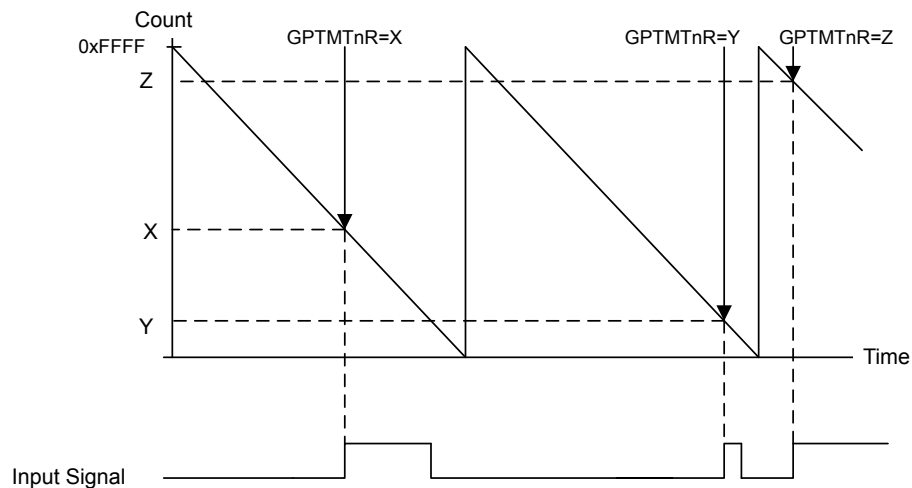

Note: When operating in Edge-time mode, the counter uses a modulo 2^{24} count if prescaler is enabled or 2^{16} , if not. If there is a possibility the edge could take longer than the count, then another timer configured in periodic-timer mode can be implemented to ensure detection of the missed edge. The periodic timer should be configured in such a way that:

- The periodic timer cycles at the same rate as the edge-time timer
- The periodic timer interrupt has a higher interrupt priority than the edge-time timeout interrupt.
- If the periodic timer interrupt service routine is entered, software must check if an edge-time interrupt is pending and if it is, the value of the counter must be subtracted by 1 before being used to calculate the snapshot time of the event.

16.3.3.5 PWM Mode

The GPTM supports a simple PWM generation mode. In PWM mode, the timer is configured as a 24-bit down-counter with a start value (and thus period) defined by the **GPTMTnILR** and **GPTMTnPR** registers. In this mode, the PWM frequency and period are synchronous events and therefore guaranteed to be glitch free. PWM mode is enabled with the **GPTMTnMR** register by setting the **TnAMS** bit to 0x1, the **TnCMR** bit to 0x0, and the **TnMR** field to 0x2. Table 16-9 on page 1090 shows the values that are loaded into the timer registers when the timer is enabled.

Table 16-9. Counter Values When the Timer is Enabled in PWM Mode

Register	Count Down Mode	Count Up Mode
GPTMTnR	GPTMTnILR	Not available
GPTMTnV	GPTMTnILR	Not available

When software writes the **TnEN** bit in the **GPTMCTL** register, the counter begins counting down until it reaches the 0x0 state. Alternatively, if the **TnWOT** bit is set in the **GPTMTnMR** register, once the **TnEN** bit is set, the timer waits for a trigger to begin counting (see “Wait-for-Trigger Mode” on page 1092). On the next counter cycle in periodic mode, the counter reloads its start value from the **GPTMTnILR** and **GPTMTnPR** registers and continues counting until disabled by software clearing the **TnEN** bit in the **GPTMCTL** register. The timer is capable of generating interrupts based on three types of events: rising edge, falling edge, or both. The event is configured by the **TnEVENT** field of the **GPTMCTL** register, and the interrupt is enabled by setting the **TnPWMIE** bit in the **GPTMTnMR** register. When the event occurs, the **CnERIS** bit is set in the **GPTM Raw Interrupt Status (GPTMRIS)** register, and holds it until it is cleared by writing the **GPTM Interrupt Clear (GPTMICR)** register. If the capture mode event interrupt is enabled in the **GPTM Interrupt Mask (GPTMIMR)** register, the GPTM also sets the **CnEMIS** bit in the **GPTM Masked Interrupt Status (GPTMMIS)** register. Note that the interrupt status bits are not updated unless the **TnPWMIE** bit is set.

In addition, when the **TnPWMIE** bit is set and a capture event occurs, the Timer automatically generates triggers to the ADC and DMA if the trigger capability is enabled by setting the **TnOTE** bit in the **GPTMCTL** register and the **CnEDMAEN** bit in the **GPTMDMAEV** register, respectively.

In this mode, the **GPTMTnR** and **GPTMTnV** registers always have the same value.

The output PWM signal asserts when the counter is at the value of the **GPTMTnILR** and **GPTMTnPR** registers (its start state), and is deasserted when the counter value equals the value in the **GPTMTnMATCHR** and **GPTMTnPMR** registers. Software has the capability of inverting the output PWM signal by setting the **TnPWML** bit in the **GPTMCTL** register.

Note: If PWM output inversion is enabled, edge detection interrupt behavior is reversed. Thus, if a positive-edge interrupt trigger has been set and the PWM inversion generates a positive edge, no event-trigger interrupt asserts. Instead, the interrupt is generated on the negative edge of the PWM signal.

Figure 16-4 on page 1091 shows how to generate an output PWM with a 1-ms period and a 66% duty cycle assuming a 50-MHz input clock and **TnPWML** = 0 (duty cycle would be 33% for the **TnPWML** = 1 configuration). For this example, the start value is **GPTMTnILR**=0xC350 and the match value is **GPTMTnMATCHR**=0x411A.

Figure 16-4. 16-Bit PWM Mode Example

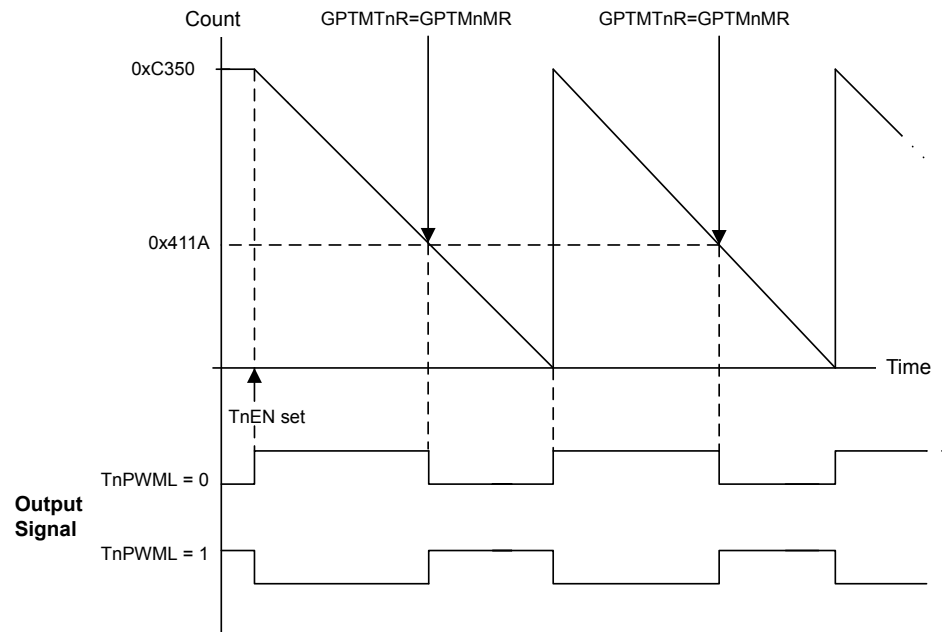

When synchronizing the timers using the **GPTMSYNC** register, the timer must be properly configured to avoid glitches on the CCP outputs. Both the $TnPLO$ and the $TnMRSU$ bits must be set in the **GPTMTnMR** register. Figure 16-5 on page 1091 shows how the CCP output operates when the $TnPLO$ and $TnMRSU$ bits are set and the **GPTMTnMATCHR** value is greater than the **GPTMTnILR** value.

Figure 16-5. CCP Output, $GPTMTnMATCHR > GPTMTnILR$ 

Figure 16-6 on page 1092 shows how the CCP output operates when the PLO and $MRSU$ bits are set and the **GPTMTnMATCHR** value is the same as the **GPTMTnILR** value. In this situation, if the PLO bit is 0, the CCP signal goes high when the **GPTMTnILR** value is loaded and the match would be essentially ignored.

Figure 16-6. CCP Output, GPTMTnMATCHR = GPTMTnILR



Figure 16-7 on page 1092 shows how the CCP output operates when the `PLO` and `MRSU` bits are set and the `GPTMTnILR` is greater than the `GPTMTnMATCHR` value.

Figure 16-7. CCP Output, GPTMTnILR > GPTMTnMATCHR



16.3.4 Wait-for-Trigger Mode

The Wait-for-Trigger mode allows daisy chaining of the timer modules such that once configured, a single timer can initiate multiple timing events using the Timer triggers. Wait-for-Trigger mode is enabled by setting the `TnWOT` bit in the `GPTMTnMR` register. When the `TnWOT` bit is set, Timer N+1 does not begin counting until the timer in the previous position in the daisy chain (Timer N) reaches its time-out event. The daisy chain is configured such that GPTM1 always follows GPTM0, GPTM2 follows GPTM1, and so on. If Timer A is configured as a 32-bit (16/32-bit mode) timer (controlled by the `GPTMCFG` field in the `GPTMCFG` register), it triggers Timer A in the next module. If Timer A is configured as a 16-bit (16/32-bit mode) timer, it triggers Timer B in the same module, and Timer B triggers Timer A in the next module. Figure 16-8 on page 1093 shows how the `GPTMCFG` bit affects the daisy chain. This function is valid for one-shot, periodic, and PWM modes.

Note: If the application requires cyclical daisy-chaining, the `TAWOT` bit in the `GPTMTAMR` register of Timer 0 can be set. In this case, Timer 0 waits for a trigger from the last timer module in the chain.

Figure 16-8. Timer Daisy Chain

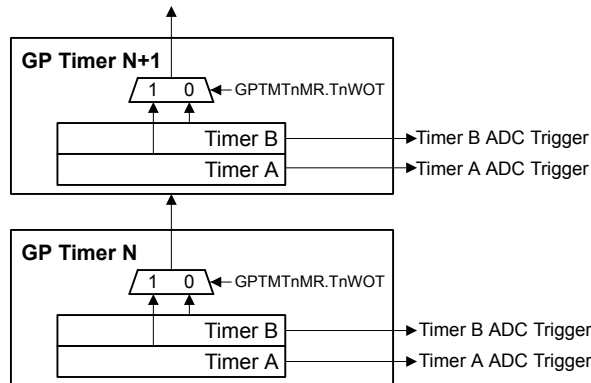

16.3.5 Synchronizing GP Timer Blocks

The **GPTM Synchronizer Control (GPTMSYNC)** register in the GPTM0 block can be used to synchronize selected timers to begin counting at the same time. Setting a bit in the **GPTMSYNC** register causes the associated timer to perform the actions of a timeout event. An interrupt is not generated when the timers are synchronized. If a timer is being used in concatenated mode, only the bit for Timer A must be set in the **GPTMSYNC** register.

Note: All timers must use the same clock source for this feature to work correctly.

Table 16-10 on page 1093 shows the actions for the timeout event performed when the timers are synchronized in the various timer modes.

Table 16-10. Timeout Actions for GPTM Modes

Mode	Count Dir	Time Out Action
32-bit One-Shot (concatenated timers)	—	N/A
32-bit Periodic (concatenated timers)	Down	Count value = ILR
	Up	Count value = 0
32-bit RTC (concatenated timers)	Up	Count value = 0
16-bit One Shot (individual/split timers)	—	N/A
16-bit Periodic (individual/split timers)	Down	Count value = ILR
	Up	Count value = 0
16-bit Edge-Count (individual/split timers)	Down	Count value = ILR
	Up	Count value = 0
16-bit Edge-Time (individual/split timers)	Down	Count value = ILR
	Up	Count value = 0
16-bit PWM	Down	Count value = ILR

16.3.6 DMA Operation

The timers each have a dedicated μ DMA channel and can provide a request signal to the μ DMA controller. Pulse requests are generated by a timer via its own `dma_req` signal. A `dma_done` signal is provided from the μ DMA to each timer to indicate transfer completion and trigger a μ DMA done interrupt (`DMAnRIS`) in the **GPTM Raw Interrupt Status Register (GPTMRIS) register**. The request is a burst type and occurs whenever a timer raw interrupt condition occurs. The arbitration size of the μ DMA transfer should be set to the amount of data that should be transferred whenever a timer event occurs.

For example, to transfer 256 items, 8 items at a time every 10 ms, configure a timer to generate a periodic timeout at 10 ms. Configure the μ DMA transfer for a total of 256 items, with a burst size of 8 items. Each time the timer times out, the μ DMA controller transfers 8 items, until all 256 items have been transferred. Refer to “Micro Direct Memory Access (μ DMA)” on page 686 for more details about programming the μ DMA controller.

A **GPTM DMA Event (GPTMDMAEV) register** is provided to enable the types of events that can cause a `dma_req` signal assertion by the timer module. Application software can enable a `dma_req` trigger for a match, capture or time-out event for each timer using the **GPTMDMAEV** register. For an individual timer, all active timer trigger events that have been enabled through the **GPTMDMAEV** register are ORed together to create a single `dma_req` pulse that is sent to the μ DMA. When the μ DMA transfer has completed, a `dma_done` signal is sent to the timer resulting in a `DMAnRIS` bit set in the **GPTMRIS** register.

16.3.7 ADC Operation

The timer has the capability to trigger the ADC when the `TnOTE` bit is set in the **GPTMCTL** register at offset `0x00C`. The **GPTM ADC Event (GPTMADCEV) register** is additionally provided so that the type of ADC trigger can be defined. For example, by setting the `CBMADCEN` bit in the **GPTMADCEV** register, a trigger pulse will be sent to the ADC whenever a Capture Match event occurs in GPTM B. Similar to the μ DMA operation, all active trigger events that have also been enabled in the **GPTMADCEV** register are ORed together to create an ADC trigger pulse.

16.3.8 Accessing Concatenated 16/32-Bit GPTM Register Values

The GPTM is placed into concatenated mode by writing a `0x0` or a `0x1` to the `GPTMCFG` bit field in the **GPTM Configuration (GPTMCFG) register**. In both configurations, certain 16/32-bit GPTM registers are concatenated to form pseudo 32-bit registers. These registers include:

- **GPTM Timer A Interval Load (GPTMTAILR) register** [15:0], see page 1128
- **GPTM Timer B Interval Load (GPTMTBILR) register** [15:0], see page 1129
- **GPTM Timer A (GPTMTAR) register** [15:0], see page 1136
- **GPTM Timer B (GPTMTBR) register** [15:0], see page 1137
- **GPTM Timer A Value (GPTMTAV) register** [15:0], see page 1138
- **GPTM Timer B Value (GPTMTBV) register** [15:0], see page 1139
- **GPTM Timer A Match (GPTMTAMATCHR) register** [15:0], see page 1130
- **GPTM Timer B Match (GPTMTBMATCHR) register** [15:0], see page 1131

In the 32-bit modes, the GPTM translates a 32-bit write access to **GPTMTAILR** into a write access to both **GPTMTAILR** and **GPTMTBILR**. The resulting word ordering for such a write operation is:

```
GPTMTBILR[15:0]:GPTMTAILR[15:0]
```

Likewise, a 32-bit read access to **GPTMTAR** returns the value:

```
GPTMTBR[15:0]:GPTMTAR[15:0]
```

A 32-bit read access to **GPTMTAV** returns the value:

```
GPTMTBV[15:0]:GPTMTAV[15:0]
```

16.4 Initialization and Configuration

To use a GPTM, the appropriate **TIMERN** bit must be set in the **RCGCTIMER** register (see page 387). If using any CCP pins, the clock to the appropriate GPIO module must be enabled via the **RCGCGPIO** register (see page 389). To find out which GPIO port to enable, refer to Table 29-4 on page 1921. Configure the **PMCn** fields in the **GPIOPCTL** register to assign the CCP signals to the appropriate pins (see page 795 and Table 29-5 on page 1932).

This section shows module initialization and configuration examples for each of the supported timer modes.

16.4.1 One-Shot/Periodic Timer Mode

The GPTM is configured for One-Shot and Periodic modes by the following sequence:

1. Ensure the timer is disabled (the **TnEN** bit in the **GPTMCTL** register is cleared) before making any changes.
2. Write the **GPTM Configuration Register (GPTMCFG)** with a value of 0x0000.0000.
3. Configure the **TnMR** field in the **GPTM Timer n Mode Register (GPTMTnMR)**:
 - a. Write a value of 0x1 for One-Shot mode.
 - b. Write a value of 0x2 for Periodic mode.
4. Optionally configure the **TnSNAPS**, **TnWOT**, **TnMTE**, and **TnCDIR** bits in the **GPTMTnMR** register to select whether to capture the value of the free-running timer at time-out, use an external trigger to start counting, configure an additional trigger or interrupt, and count up or down. In addition, if using CCP pins, the **TnCACT** field can be programmed to configure the compare action.
5. Load the start value into the **GPTM Timer n Interval Load Register (GPTMTnILR)**.
6. If interrupts are required, set the appropriate bits in the **GPTM Interrupt Mask Register (GPTMIMR)**.
7. Set the **TnEN** bit in the **GPTMCTL** register to enable the timer and start counting.
8. Poll the **GPTMRIS** register or wait for the interrupt to be generated (if enabled). In both cases, the status flags are cleared by writing a 1 to the appropriate bit of the **GPTM Interrupt Clear Register (GPTMICR)**.

If the `TnMIE` bit in the **GPTMTnMR** register is set, the `RTCRES` bit in the **GPTMRIS** register is set, and the timer continues counting. In One-Shot mode, the timer stops counting after the time-out event. To re-enable the timer, repeat the sequence. A timer configured in Periodic mode reloads the timer and continues counting after the time-out event.

16.4.2 Real-Time Clock (RTC) Mode

To use the RTC mode, the timer must have a 32.768-KHz input signal on an even CCP input. To enable the RTC feature, follow these steps:

1. Ensure the timer is disabled (the `TAEN` bit is cleared) before making any changes.
2. If the timer has been operating in a different mode prior to this, clear any residual set bits in the **GPTM Timer n Mode (GPTMTnMR)** register before reconfiguring.
3. Write the **GPTM Configuration Register (GPTMCFG)** with a value of `0x0000.0001`.
4. Write the match value to the **GPTM Timer n Match Register (GPTMTnMATCHR)**.
5. Set/clear the `RTCEN` and `TnSTALL` bit in the **GPTM Control Register (GPTMCTL)** as needed.
6. If interrupts are required, set the `RTCIM` bit in the **GPTM Interrupt Mask Register (GPTMIMR)**.
7. Set the `TAEN` bit in the **GPTMCTL** register to enable the timer and start counting.

When the timer count equals the value in the **GPTMTnMATCHR** register, the GPTM asserts the `RTCRES` bit in the **GPTMRIS** register and continues counting until Timer A is disabled or a hardware reset. The interrupt is cleared by writing the `RTCCINT` bit in the **GPTMICR** register. Note that if the **GPTMTnILR** register is loaded with a new value, the timer begins counting at this new value and continues until it reaches `0xFFFF.FFFF`, at which point it rolls over.

16.4.3 Input Edge-Count Mode

A timer is configured to Input Edge-Count mode by the following sequence:

1. Ensure the timer is disabled (the `TnEN` bit is cleared) before making any changes.
2. Write the **GPTM Configuration (GPTMCFG)** register with a value of `0x0000.0004`.
3. In the **GPTM Timer Mode (GPTMTnMR)** register, write the `TnCMR` field to `0x0` and the `TnMR` field to `0x3`.
4. Configure the type of event(s) that the timer captures by writing the `TnEVENT` field of the **GPTM Control (GPTMCTL)** register.
5. Program registers according to count direction:
 - In down-count mode, the **GPTMTnMATCHR** and **GPTMTnPMR** registers are configured so that the difference between the value in the **GPTMTnILR** and **GPTMTnPR** registers and the **GPTMTnMATCHR** and **GPTMTnPMR** registers equals the number of edge events that must be counted.
 - In up-count mode, the timer counts from `0x0` to the value in the **GPTMTnMATCHR** and **GPTMTnPMR** registers. Note that when executing an up-count, the value of the **GPTMTnPR** and **GPTMTnILR** must be greater than the value of **GPTMTnPMR** and **GPTMTnMATCHR**.

6. If interrupts are required, set the $CnMIM$ bit in the **GPTM Interrupt Mask (GPTMIMR)** register.
7. Set the $TnEN$ bit in the **GPTMCTL** register to enable the timer and begin waiting for edge events.
8. Poll the $CnMRIS$ bit in the **GPTMRIS** register or wait for the interrupt to be generated (if enabled). In both cases, the status flags are cleared by writing a 1 to the $CnMCINT$ bit of the **GPTM Interrupt Clear (GPTMICR)** register.

When counting down in Input Edge-Count Mode, the timer stops after the programmed number of edge events has been detected. To re-enable the timer, ensure that the $TnEN$ bit is cleared and repeat steps 4 through 8.

16.4.4 Input Edge Time Mode

A timer is configured to Input Edge Time mode by the following sequence:

1. Ensure the timer is disabled (the $TnEN$ bit is cleared) before making any changes.
2. Write the **GPTM Configuration (GPTMCFG)** register with a value of 0x0000.0004.
3. In the **GPTM Timer Mode (GPTMTnMR)** register, write the $TnCMR$ field to 0x1 and the $TnMR$ field to 0x3 and select a count direction by programming the $TnCDIR$ bit.
4. Configure the type of event that the timer captures by writing the $TnEVENT$ field of the **GPTM Control (GPTMCTL)** register.
5. If a prescaler is to be used, write the prescale value to the **GPTM Timer n Prescale Register (GPTMTnPR)**.
6. Load the timer start value into the **GPTM Timer n Interval Load (GPTMTnILR)** register.
7. If interrupts are required, set the $CnEIM$ bit in the **GPTM Interrupt Mask (GPTMIMR)** register.
8. Set the $TnEN$ bit in the **GPTM Control (GPTMCTL)** register to enable the timer and start counting.
9. Poll the $CnERIS$ bit in the **GPTMRIS** register or wait for the interrupt to be generated (if enabled). In both cases, the status flags are cleared by writing a 1 to the $CnECINT$ bit of the **GPTM Interrupt Clear (GPTMICR)** register. The time at which the event happened can be obtained by reading the **GPTM Timer n (GPTMTnR)** register.

In Input Edge Timing mode, the timer continues running after an edge event has been detected, but the timer interval can be changed at any time by writing the **GPTMTnILR** register and clearing the $TnILD$ bit in the **GPTMTnMR** register. The change takes effect at the next cycle after the write.

16.4.5 PWM Mode

A timer is configured to PWM mode using the following sequence:

1. Ensure the timer is disabled (the $TnEN$ bit is cleared) before making any changes.
2. Write the **GPTM Configuration (GPTMCFG)** register with a value of 0x0000.0004.
3. In the **GPTM Timer Mode (GPTMTnMR)** register, set the $TnAMS$ bit to 0x1, the $TnCMR$ bit to 0x0, and the $TnMR$ field to 0x2.

4. Configure the output state of the PWM signal (whether or not it is inverted) in the T_nPWML field of the **GPTM Control (GPTMCTL)** register.
5. If a prescaler is to be used, write the prescale value to the **GPTM Timer n Prescale Register (GPTMTnPR)**.
6. If PWM interrupts are used, configure the interrupt condition in the T_nEVENT field in the **GPTMCTL** register and enable the interrupts by setting the T_nPWMIE bit in the **GPTMTnMR** register. Note that edge detect interrupt behavior is reversed when the PWM output is inverted (see page 1110).
7. Load the timer start value into the **GPTM Timer n Interval Load (GPTMTnILR)** register.
8. Load the **GPTM Timer n Match (GPTMTnMATCHR)** register with the match value.
9. Set the T_nEN bit in the **GPTM Control (GPTMCTL)** register to enable the timer and begin generation of the output PWM signal.

In PWM Time mode, the timer continues running after the PWM signal has been generated. The PWM period can be adjusted at any time by writing the **GPTMTnILR** register, and the change takes effect at the next cycle after the write.

16.5 Register Map

Table 16-11 on page 1098 lists the GPTM registers. The offset listed is a hexadecimal increment to the register's address, relative to that timer's base address:

- 16/32-bit Timer 0: 0x4003.0000
- 16/32-bit Timer 1: 0x4003.1000
- 16/32-bit Timer 2: 0x4003.2000
- 16/32-bit Timer 3: 0x4003.3000
- 16/32-bit Timer 4: 0x4003.4000
- 16/32-bit Timer 5: 0x4003.5000
- 16/32-bit Timer 6: 0x400E.0000
- 16/32-bit Timer 7: 0x400E.1000

Note that the GP Timer module clock must be enabled before the registers can be programmed (see page 387). There must be a delay of 3 system clocks after the Timer module clock is enabled before any Timer module registers are accessed.

Table 16-11. Timers Register Map

Offset	Name	Type	Reset	Description	See page
0x000	GPTMCFG	RW	0x0000.0000	GPTM Configuration	1100
0x004	GPTMTAMR	RW	0x0000.0000	GPTM Timer A Mode	1101
0x008	GPTMTBMR	RW	0x0000.0000	GPTM Timer B Mode	1106
0x00C	GPTMCTL	RW	0x0000.0000	GPTM Control	1110
0x010	GPTMSYNC	RW	0x0000.0000	GPTM Synchronize	1114
0x018	GPTMIMR	RW	0x0000.0000	GPTM Interrupt Mask	1117

Table 16-11. Timers Register Map (continued)

Offset	Name	Type	Reset	Description	See page
0x01C	GPTMRIS	RO	0x0000.0000	GPTM Raw Interrupt Status	1120
0x020	GPTMMIS	RO	0x0000.0000	GPTM Masked Interrupt Status	1123
0x024	GPTMICR	W1C	0x0000.0000	GPTM Interrupt Clear	1126
0x028	GPTMTAILR	RW	0xFFFF.FFFF	GPTM Timer A Interval Load	1128
0x02C	GPTMTBILR	RW	0x0000.FFFF	GPTM Timer B Interval Load	1129
0x030	GPTMTAMATCHR	RW	0xFFFF.FFFF	GPTM Timer A Match	1130
0x034	GPTMTBMATCHR	RW	0x0000.FFFF	GPTM Timer B Match	1131
0x038	GPTMTAPR	RW	0x0000.0000	GPTM Timer A Prescale	1132
0x03C	GPTMTBPR	RW	0x0000.0000	GPTM Timer B Prescale	1133
0x040	GPTMTAPMR	RW	0x0000.0000	GPTM TimerA Prescale Match	1134
0x044	GPTMTBPMR	RW	0x0000.0000	GPTM TimerB Prescale Match	1135
0x048	GPTMTAR	RO	0xFFFF.FFFF	GPTM Timer A	1136
0x04C	GPTMTBR	RO	0x0000.FFFF	GPTM Timer B	1137
0x050	GPTMTAV	RW	0xFFFF.FFFF	GPTM Timer A Value	1138
0x054	GPTMTBV	RW	0x0000.FFFF	GPTM Timer B Value	1139
0x058	GPTMRTCPD	RO	0x0000.7FFF	GPTM RTC Predivide	1140
0x05C	GPTMTAPS	RO	0x0000.0000	GPTM Timer A Prescale Snapshot	1141
0x060	GPTMTBPS	RO	0x0000.0000	GPTM Timer B Prescale Snapshot	1142
0x06C	GPTMDMAEV	RW	0x0000.0000	GPTM DMA Event	1143
0x070	GPTMADCEV	RW	0x0000.0000	GPTM ADC Event	1146
0xFC0	GPTMPP	RO	0x0000.0070	GPTM Peripheral Properties	1149
0xFC8	GPTMCC	RW	0x0000.0000	GPTM Clock Configuration	1151

16.6 Register Descriptions

The remainder of this section lists and describes the GPTM registers, in numerical order by address offset.

Register 1: GPTM Configuration (GPTMCFG), offset 0x000

This register configures the global operation of the GPTM module. The value written to this register determines whether the GPTM is in 32- or 16-bit mode.

Important: Bits in this register should only be changed when the TAEN and TBEN bits in the GPTMCTL register are cleared.

GPTM Configuration (GPTMCFG)

16/32-bit Timer 0 base: 0x4003.0000
 16/32-bit Timer 1 base: 0x4003.1000
 16/32-bit Timer 2 base: 0x4003.2000
 16/32-bit Timer 3 base: 0x4003.3000
 16/32-bit Timer 4 base: 0x4003.4000
 16/32-bit Timer 5 base: 0x4003.5000
 16/32-bit Timer 6 base: 0x400E.0000
 16/32-bit Timer 7 base: 0x400E.1000
 Offset 0x000
 Type RW, reset 0x0000.0000

	31	30	29	28	27	26	25	24	23	22	21	20	19	18	17	16	
	reserved																
Type	RO	RO	RO	RO	RO	RO	RO	RO	RO	RO	RO	RO	RO	RO	RO	RO	
Reset	0	0	0	0	0	0	0	0	0	0	0	0	0	0	0	0	
	15	14	13	12	11	10	9	8	7	6	5	4	3	2	1	0	
	reserved													GPTMCFG			
Type	RO	RO	RO	RO	RO	RO	RO	RO	RO	RO	RO	RO	RO	RO	RW	RW	RW
Reset	0	0	0	0	0	0	0	0	0	0	0	0	0	0	0	0	0

Bit/Field	Name	Type	Reset	Description												
31:3	reserved	RO	0x0000.000	Software should not rely on the value of a reserved bit. To provide compatibility with future products, the value of a reserved bit should be preserved across a read-modify-write operation.												
2:0	GPTMCFG	RW	0x0	GPTM Configuration The GPTMCFG values are defined as follows: <table border="0"> <tr> <td>Value</td> <td>Description</td> </tr> <tr> <td>0x0</td> <td>For a 16/32-bit timer, this value selects the 32-bit timer configuration.</td> </tr> <tr> <td>0x1</td> <td>For a 16/32-bit timer, this value selects the 32-bit real-time clock (RTC) counter configuration.</td> </tr> <tr> <td>0x2-0x3</td> <td>Reserved</td> </tr> <tr> <td>0x4</td> <td>For a 16/32-bit timer, this value selects the 16-bit timer configuration. The function is controlled by bits 1:0 of GPTMTAMR and GPTMTBMR.</td> </tr> <tr> <td>0x5-0x7</td> <td>Reserved</td> </tr> </table>	Value	Description	0x0	For a 16/32-bit timer, this value selects the 32-bit timer configuration.	0x1	For a 16/32-bit timer, this value selects the 32-bit real-time clock (RTC) counter configuration.	0x2-0x3	Reserved	0x4	For a 16/32-bit timer, this value selects the 16-bit timer configuration. The function is controlled by bits 1:0 of GPTMTAMR and GPTMTBMR.	0x5-0x7	Reserved
Value	Description															
0x0	For a 16/32-bit timer, this value selects the 32-bit timer configuration.															
0x1	For a 16/32-bit timer, this value selects the 32-bit real-time clock (RTC) counter configuration.															
0x2-0x3	Reserved															
0x4	For a 16/32-bit timer, this value selects the 16-bit timer configuration. The function is controlled by bits 1:0 of GPTMTAMR and GPTMTBMR.															
0x5-0x7	Reserved															

Register 2: GPTM Timer A Mode (GPTMTAMR), offset 0x004

This register configures the GPTM based on the configuration selected in the **GPTMCFG** register. When in PWM mode, set the **TAAMS** bit, clear the **TACMR** bit, and configure the **TAMR** field to 0x1 or 0x2.

This register controls the modes for Timer A when it is used individually. When Timer A and Timer B are concatenated, this register controls the modes for both Timer A and Timer B, and the contents of **GPTMTBMR** are ignored.

Important: Except for the **TCACT** bit field, all other bits in this register should only be changed when the **TAEN** bit in the **GPTMCTL** register is cleared.

GPTM Timer A Mode (GPTMTAMR)

16/32-bit Timer 0 base: 0x4003.0000
 16/32-bit Timer 1 base: 0x4003.1000
 16/32-bit Timer 2 base: 0x4003.2000
 16/32-bit Timer 3 base: 0x4003.3000
 16/32-bit Timer 4 base: 0x4003.4000
 16/32-bit Timer 5 base: 0x4003.5000
 16/32-bit Timer 6 base: 0x400E.0000
 16/32-bit Timer 7 base: 0x400E.1000
 Offset 0x004

Type RW, reset 0x0000.0000

	31	30	29	28	27	26	25	24	23	22	21	20	19	18	17	16
	reserved															
Type	RO	RO	RO	RO	RO	RO	RO	RO	RO	RO	RO	RO	RO	RO	RO	RO
Reset	0	0	0	0	0	0	0	0	0	0	0	0	0	0	0	0
	15	14	13	12	11	10	9	8	7	6	5	4	3	2	1	0
	TCACT		TACINTD	TAPLO	TAMRSU	TAPWMIE	TAILD	TASNAPS	TAWOT	TAMIE	TACDIR	TAAMS	TACMR	TAMR		
Type	RW	RW	RW	RW	RW	RW	RW	RW	RW	RW	RW	RW	RW	RW	RW	RW
Reset	0	0	0	0	0	0	0	0	0	0	0	0	0	0	0	0

Bit/Field	Name	Type	Reset	Description
31:16	reserved	RO	0x0000.00	Software should not rely on the value of a reserved bit. To provide compatibility with future products, the value of a reserved bit should be preserved across a read-modify-write operation.
15:13	TCACT	RW	0x0	Timer Compare Action Select
	Value	Description		
	0x0	Disable compare operations.		
	0x1	Toggle State on Time-Out		
	0x2	Clear CCP on Time-Out		
	0x3	Set CCP on Time-Out		
	0x4	Set CCP immediately and toggle on Time-Out		
	0x5	Clear CCP immediately and toggle on Time-Out		
	0x6	Set CCP immediately and clear on Time-Out		
	0x7	Clear CCP immediately and set on Time-Out		

Bit/Field	Name	Type	Reset	Description
12	TACINTD	RW	0	<p>One-shot/Periodic Interrupt Disable</p> <p>Value Description</p> <p>0 Time-out interrupt functions as normal.</p> <p>1 Time-out interrupt are disabled.</p> <p>Note: Setting the TACINTD bit in the GPTMTAMR register does not have an effect on the μDMA or ADC interrupt time-out event trigger assertions. If the TATODMAEN bit is set in the GPTMDMAEV register or the TATOADCEN bit is set in the GPTMADCEV register, a μDMA or ADC time-out trigger is sent to the μDMA or ADC, respectively, even if the TACINTD bit is set.</p>
11	TAPLO	RW	0	<p>GPTM Timer A PWM Legacy Operation</p> <p>Value Description</p> <p>0 Legacy operation with CCP pin driven Low when the GPTMTAILR is reloaded after the timer reaches 0.</p> <p>1 CCP is driven High when the GPTMTAILR is reloaded after the timer reaches 0.</p> <p>This bit is only valid in PWM mode.</p>
10	TAMRSU	RW	0	<p>GPTM Timer A Match Register Update</p> <p>Value Description</p> <p>0 Update the GPTMTAMATCHR register and the GPTMTAPR register, if used, on the next cycle.</p> <p>1 Update the GPTMTAMATCHR register and the GPTMTAPR register, if used, on the next timeout.</p> <p>If the timer is disabled (TAEN is clear) when this bit is set, GPTMTAMATCHR and GPTMTAPR are updated when the timer is enabled. If the timer is stalled (TASTALL is set), GPTMTAMATCHR and GPTMTAPR are updated according to the configuration of this bit.</p>
9	TAPWMIE	RW	0	<p>GPTM Timer A PWM Interrupt Enable</p> <p>This bit enables interrupts in PWM mode on rising, falling, or both edges of the CCP output, as defined by the TAEVENT field in the GPTMCTL register.</p> <p>In addition, when this bit is set and a capture event occurs, Timer A automatically generates triggers to the ADC and DMA if the trigger capability is enabled by setting the TAOTE bit in the GPTMCTL register and the CAEDMAEN bit in the GPTMDMAEV register, respectively.</p> <p>Value Description</p> <p>0 Capture event interrupt is disabled.</p> <p>1 Capture event interrupt is enabled.</p> <p>This bit is only valid in PWM mode.</p>

Bit/Field	Name	Type	Reset	Description
8	TAILD	RW	0	<p>GPTM Timer A Interval Load Write</p> <p>Value Description</p> <p>0 Update the GPTMTAR and GPTMTAV registers with the value in the GPTMTAILR register on the next cycle. Also update the GPTMTAPS register with the value in the GPTMTAPR register on the next cycle.</p> <p>1 Update the GPTMTAR and GPTMTAV registers with the value in the GPTMTAILR register on the next timeout. Also update the GPTMTAPS register with the value in the GPTMTAPR register on the next timeout.</p> <p>Note the state of this bit has no effect when counting up.</p> <p>The bit descriptions above apply if the timer is enabled and running. If the timer is disabled (TAEN is clear) when this bit is set, GPTMTAR, GPTMTAV and GPTMTAPs, are updated when the timer is enabled. If the timer is stalled (TASTALL is set), GPTMTAR and GPTMTAPS are updated according to the configuration of this bit.</p>
7	TASNAPS	RW	0	<p>GPTM Timer A Snap-Shot Mode</p> <p>Value Description</p> <p>0 Snap-shot mode is disabled.</p> <p>1 If Timer A is configured in the periodic mode, the actual free-running, capture or snapshot value of Timer A is loaded at the time-out event/capture or snapshot event into the GPTM Timer A (GPTMTAR) register. If the timer prescaler is used, the prescaler snapshot is loaded into the GPTM Timer A (GPTMTAPR).</p>
6	TAWOT	RW	0	<p>GPTM Timer A Wait-on-Trigger</p> <p>Note: If the application requires cyclical daisy-chaining, the TAWOT bit in the GPTMTAMR register of Timer 0 can be set. In this case, Timer 0 waits for a trigger from the last timer module in the chain.</p> <p>Value Description</p> <p>0 Timer A begins counting as soon as it is enabled.</p> <p>1 If Timer A is enabled (TAEN is set in the GPTMCTL register), Timer A does not begin counting until it receives a trigger from the timer in the previous position in the daisy chain, see Figure 16-8 on page 1093. This function is valid for one-shot, periodic, and PWM modes.</p>

Bit/Field	Name	Type	Reset	Description
5	TAMIE	RW	0	<p>GPTM Timer A Match Interrupt Enable</p> <p>Value Description</p> <p>0 The match interrupt is disabled for match events.</p> <p>Note: Clearing the TAMIE bit in the GPTMTAMR register prevents assertion of μDMA or ADC requests generated on a match event. Even if the TATODMAEN bit is set in the GPTMDMAEV register or the TATOADCEN bit is set in the GPTMADCEV register, a μDMA or ADC match trigger is not sent to the μDMA or ADC, respectively, when the TAMIE bit is clear.</p> <p>1 An interrupt is generated when the match value in the GPTMTAMATCHR register is reached in the one-shot and periodic modes.</p>
4	TACDIR	RW	0	<p>GPTM Timer A Count Direction</p> <p>Value Description</p> <p>0 The timer counts down.</p> <p>1 The timer counts up. When counting up, the timer starts from a value of 0x0.</p> <p>When in PWM or RTC mode, the status of this bit is ignored. PWM mode always counts down and RTC mode always counts up.</p>
3	TAAMS	RW	0	<p>GPTM Timer A Alternate Mode Select</p> <p>The TAAMS values are defined as follows:</p> <p>Value Description</p> <p>0 Capture or compare mode is enabled.</p> <p>1 PWM mode is enabled.</p> <p>Note: To enable PWM mode, you must also clear the TACMR bit and configure the TAMR field to 0x1 or 0x2.</p>
2	TACMR	RW	0	<p>GPTM Timer A Capture Mode</p> <p>The TACMR values are defined as follows:</p> <p>Value Description</p> <p>0 Edge-Count mode</p> <p>1 Edge-Time mode</p>

Bit/Field	Name	Type	Reset	Description
1:0	TAMR	RW	0x0	GPTM Timer A Mode The TAMR values are defined as follows: Value Description 0x0 Reserved 0x1 One-Shot Timer mode 0x2 Periodic Timer mode 0x3 Capture mode The Timer mode is based on the timer configuration defined by bits 2:0 in the GPTMCFG register.

Register 3: GPTM Timer B Mode (GPTMTBMR), offset 0x008

This register configures the GPTM based on the configuration selected in the **GPTMCFG** register. When in PWM mode, set the **TBAMS** bit, clear the **TBCMR** bit, and configure the **TBMR** field to 0x1 or 0x2.

This register controls the modes for Timer B when it is used individually. When Timer A and Timer B are concatenated, this register is ignored and **GPTMTAMR** controls the modes for both Timer A and Timer B.

Important: Except for the **TCACT** bit field, all other bits in this register should only be changed when the **TBEN** bit in the **GPTMCTL** register is cleared.

GPTM Timer B Mode (GPTMTBMR)

16/32-bit Timer 0 base: 0x4003.0000
 16/32-bit Timer 1 base: 0x4003.1000
 16/32-bit Timer 2 base: 0x4003.2000
 16/32-bit Timer 3 base: 0x4003.3000
 16/32-bit Timer 4 base: 0x4003.4000
 16/32-bit Timer 5 base: 0x4003.5000
 16/32-bit Timer 6 base: 0x400E.0000
 16/32-bit Timer 7 base: 0x400E.1000
 Offset 0x008
 Type RW, reset 0x0000.0000

	31	30	29	28	27	26	25	24	23	22	21	20	19	18	17	16
	reserved															
Type	RO	RO	RO	RO	RO	RO	RO	RO	RO	RO	RO	RO	RO	RO	RO	RO
Reset	0	0	0	0	0	0	0	0	0	0	0	0	0	0	0	0
	15	14	13	12	11	10	9	8	7	6	5	4	3	2	1	0
	TCACT			TBCINTD	TBPLO	TBMRSU	TBPWMIE	TBILD	TBSNAPS	TBWOT	TBMIE	TBCDIR	TBAMS	TBCMR	TBMR	
Type	RW	RW	RW	RW	RW	RW	RW	RW	RW	RW	RW	RW	RW	RW	RW	RW
Reset	0	0	0	0	0	0	0	0	0	0	0	0	0	0	0	0

Bit/Field	Name	Type	Reset	Description
31:16	reserved	RO	0x0000.00	Software should not rely on the value of a reserved bit. To provide compatibility with future products, the value of a reserved bit should be preserved across a read-modify-write operation.
15:13	TCACT	RW	0x0	Timer Compare Action Select
				Value Description
			0x0	Disable compare operations
			0x1	Toggle State on Time-Out
			0x2	Clear CCP on Time-Out
			0x3	Set CCP on Time-Out
			0x4	Set CCP immediately and toggle on Time-Out
			0x5	Clear CCP immediately and toggle on Time-Out
			0x6	Set CCP immediately and clear on Time-Out
			0x7	Clear CCP immediately and set on Time-Out

Bit/Field	Name	Type	Reset	Description
12	TBCINTD	RW	0	<p>One-Shot/Periodic Interrupt Disable</p> <p>Value Description</p> <p>0 Time-out interrupt functions normally</p> <p>1 Time-out interrupt functionality is disabled</p> <p>Note: Setting the TBCINTD bit in the GPTMTBMR register does not have an effect on the μDMA or ADC interrupt time-out event trigger assertions. If the TBODMAEN bit is set in the GPTMDMAEV register or the TBTOADCEN bit is set in the GPTMADCEV register, a μDMA or ADC time-out trigger is sent to the μDMA or ADC, respectively, even if the TBCINTD bit is set.</p>
11	TBPLO	RW	0	<p>GPTM Timer B PWM Legacy Operation</p> <p>Value Description</p> <p>0 Legacy operation with CCP pin driven Low when the GPTMTAILR is reloaded after the timer reaches 0.</p> <p>1 CCP is driven High when the GPTMTAILR is reloaded after the timer reaches 0.</p> <p>This bit is only valid in PWM mode.</p>
10	TBMRSU	RW	0	<p>GPTM Timer B Match Register Update</p> <p>Value Description</p> <p>0 Update the GPTMTBMATCHR register and the GPTMTBPR register, if used, on the next cycle.</p> <p>1 Update the GPTMTBMATCHR register and the GPTMTBPR register, if used, on the next timeout.</p> <p>If the timer is disabled (TBEN is clear) when this bit is set, GPTMTBMATCHR and GPTMTBPR are updated when the timer is enabled. If the timer is stalled (TBSTALL is set), GPTMTBMATCHR and GPTMTBPR are updated according to the configuration of this bit.</p>
9	TBPWMIE	RW	0	<p>GPTM Timer B PWM Interrupt Enable</p> <p>This bit enables interrupts in PWM mode on rising, falling, or both edges of the CCP output as defined by the TBEVENT field in the GPTMCTL register.</p> <p>In addition, when this bit is set and a capture event occurs, Timer B automatically generates triggers to the ADC and DMA if the trigger capability is enabled by setting the TBOTE bit in the GPTMCTL register and the CBEDMAEN bit in the GPTMDMAEV register, respectively.</p> <p>Value Description</p> <p>0 Capture event interrupt is disabled.</p> <p>1 Capture event is enabled.</p> <p>This bit is only valid in PWM mode.</p>

Bit/Field	Name	Type	Reset	Description
8	TBILD	RW	0	<p>GPTM Timer B Interval Load Write</p> <p>Value Description</p> <p>0 Update the GPTMTBR and GPTMTBV registers with the value in the GPTMTBILR register on the next cycle. Also update the GPTMTBPS register with the value in the GPTMTBPR register on the next cycle.</p> <p>1 Update the GPTMTBR and GPTMTBV registers with the value in the GPTMTBILR register on the next timeout. Also update the GPTMTBPS register with the value in the GPTMTBPR register on the next timeout.</p> <p>Note the state of this bit has no effect when counting up.</p> <p>The bit descriptions above apply if the timer is enabled and running. If the timer is disabled (TBEN is clear) when this bit is set, GPTMTBR, GPTMTBV and are updated when the timer is enabled. If the timer is stalled (TBSTALL is set), GPTMTBR and GPTMTBPS are updated according to the configuration of this bit.</p>
7	TBSNAPS	RW	0	<p>GPTM Timer B Snap-Shot Mode</p> <p>Value Description</p> <p>0 Snap-shot mode is disabled.</p> <p>1 If Timer B is configured in the periodic mode, the actual free-running value of Timer B is loaded at the time-out event into the GPTM Timer B (GPTMTBR) register. If the timer prescaler is used, the prescaler snapshot is loaded into the GPTM Timer B (GPTMTBPR).</p>
6	TBWOT	RW	0	<p>GPTM Timer B Wait-on-Trigger</p> <p>Value Description</p> <p>0 Timer B begins counting as soon as it is enabled.</p> <p>1 If Timer B is enabled (TBEN is set in the GPTMCTL register), Timer B does not begin counting until it receives a trigger from the timer in the previous position in the daisy chain, see . This function is valid for one-shot, periodic, and PWM modes.</p>
5	TBMIE	RW	0	<p>GPTM Timer B Match Interrupt Enable</p> <p>Value Description</p> <p>0 The match interrupt is disabled for match events. Additionally, triggers to the DMA and ADC on match events are prevented.</p> <p>1 An interrupt is generated when the match value in the GPTMTBMATCHR register is reached in the one-shot and periodic modes.</p> <p>Note: Clearing the TBMIE bit in the GPTMTBMR register prevents assertion of μDMA or ADC requests generated on a match event. Even if the TBTODMAEN bit is set in the GPTMDMAEV register or the TBTOADCEN bit is set in the GPTMADCEV register, a μDMA or ADC match trigger is not sent to the μDMA or ADC, respectively, when the TBMIE bit is clear.</p>

Bit/Field	Name	Type	Reset	Description
4	TBCDIR	RW	0	<p>GPTM Timer B Count Direction</p> <p>Value Description</p> <p>0 The timer counts down.</p> <p>1 The timer counts up. When counting up, the timer starts from a value of 0x0.</p> <p>When in PWM or RTC mode, the status of this bit is ignored. PWM mode always counts down and RTC mode always counts up.</p>
3	TBAMS	RW	0	<p>GPTM Timer B Alternate Mode Select</p> <p>The TBAMS values are defined as follows:</p> <p>Value Description</p> <p>0 Capture or compare mode is enabled.</p> <p>1 PWM mode is enabled.</p> <p>Note: To enable PWM mode, you must also clear the TBCMR bit and configure the TBMR field to 0x1 or 0x2.</p>
2	TBCMR	RW	0	<p>GPTM Timer B Capture Mode</p> <p>The TBCMR values are defined as follows:</p> <p>Value Description</p> <p>0 Edge-Count mode</p> <p>1 Edge-Time mode</p>
1:0	TBMR	RW	0x0	<p>GPTM Timer B Mode</p> <p>The TBMR values are defined as follows:</p> <p>Value Description</p> <p>0x0 Reserved</p> <p>0x1 One-Shot Timer mode</p> <p>0x2 Periodic Timer mode</p> <p>0x3 Capture mode</p> <p>The timer mode is based on the timer configuration defined by bits 2:0 in the GPTMCFG register.</p>

Register 4: GPTM Control (GPTMCTL), offset 0x00C

This register is used alongside the **GPTMCFG** and **GMTMTnMR** registers to fine-tune the timer configuration, and to enable other features such as timer stall and the output trigger. The output trigger can be used to initiate transfers on the ADC module.

Important: Bits in this register should only be changed when the **TnEN** bit for the respective timer is cleared.

GPTM Control (GPTMCTL)

16/32-bit Timer 0 base: 0x4003.0000
 16/32-bit Timer 1 base: 0x4003.1000
 16/32-bit Timer 2 base: 0x4003.2000
 16/32-bit Timer 3 base: 0x4003.3000
 16/32-bit Timer 4 base: 0x4003.4000
 16/32-bit Timer 5 base: 0x4003.5000
 16/32-bit Timer 6 base: 0x400E.0000
 16/32-bit Timer 7 base: 0x400E.1000
 Offset 0x00C
 Type RW, reset 0x0000.0000

	31	30	29	28	27	26	25	24	23	22	21	20	19	18	17	16
	reserved															
Type	RO	RO	RO	RO	RO	RO	RO	RO	RO	RO	RO	RO	RO	RO	RO	RO
Reset	0	0	0	0	0	0	0	0	0	0	0	0	0	0	0	0
	15	14	13	12	11	10	9	8	7	6	5	4	3	2	1	0
	reserved	TBPWML	TBOTE	reserved	TBEVENT	TBSTALL	TBEN	reserved	TAPWML	TAOTE	RTCEN	TAEVENT	TASTALL	TAEN		
Type	RO	RW	RW	RO	RW	RW	RW	RW	RO	RW	RW	RW	RW	RW	RW	RW
Reset	0	0	0	0	0	0	0	0	0	0	0	0	0	0	0	0

Bit/Field	Name	Type	Reset	Description
31:15	reserved	RO	0x0000	Software should not rely on the value of a reserved bit. To provide compatibility with future products, the value of a reserved bit should be preserved across a read-modify-write operation.
14	TBPWML	RW	0	GPTM Timer B PWM Output Level The TBPWML values are defined as follows: Value Description 0 Output is unaffected. 1 Output is inverted.
13	TBOTE	RW	0	GPTM Timer B Output Trigger Enable The TBOTE values are defined as follows: Value Description 0 The output Timer B ADC trigger is disabled. 1 The output Timer B ADC trigger is enabled. In addition, the ADC must be enabled and the timer selected as a trigger source with the EMn bit in the ADCEMUX register (see page 1215).
12	reserved	RO	0	Software should not rely on the value of a reserved bit. To provide compatibility with future products, the value of a reserved bit should be preserved across a read-modify-write operation.

Bit/Field	Name	Type	Reset	Description										
11:10	TBEVENT	RW	0x0	<p>GPTM Timer B Event Mode</p> <p>The TBEVENT values are defined as follows:</p> <table border="1"> <thead> <tr> <th>Value</th> <th>Description</th> </tr> </thead> <tbody> <tr> <td>0x0</td> <td>Positive edge</td> </tr> <tr> <td>0x1</td> <td>Negative edge</td> </tr> <tr> <td>0x2</td> <td>Reserved</td> </tr> <tr> <td>0x3</td> <td>Both edges</td> </tr> </tbody> </table> <p>Note: If PWM output inversion is enabled, edge detection interrupt behavior is reversed. Thus, if a positive-edge interrupt trigger has been set and the PWM inversion generates a positive edge, no event-trigger interrupt asserts. Instead, the interrupt is generated on the negative edge of the PWM signal.</p>	Value	Description	0x0	Positive edge	0x1	Negative edge	0x2	Reserved	0x3	Both edges
Value	Description													
0x0	Positive edge													
0x1	Negative edge													
0x2	Reserved													
0x3	Both edges													
9	TBSTALL	RW	0	<p>GPTM Timer B Stall Enable</p> <p>The TBSTALL values are defined as follows:</p> <table border="1"> <thead> <tr> <th>Value</th> <th>Description</th> </tr> </thead> <tbody> <tr> <td>0</td> <td>Timer B continues counting while the processor is halted by the debugger.</td> </tr> <tr> <td>1</td> <td>Timer B freezes counting while the processor is halted by the debugger.</td> </tr> </tbody> </table> <p>If the processor is executing normally, the TBSTALL bit is ignored.</p>	Value	Description	0	Timer B continues counting while the processor is halted by the debugger.	1	Timer B freezes counting while the processor is halted by the debugger.				
Value	Description													
0	Timer B continues counting while the processor is halted by the debugger.													
1	Timer B freezes counting while the processor is halted by the debugger.													
8	TBEN	RW	0	<p>GPTM Timer B Enable</p> <p>The TBEN values are defined as follows:</p> <table border="1"> <thead> <tr> <th>Value</th> <th>Description</th> </tr> </thead> <tbody> <tr> <td>0</td> <td>Timer B is disabled.</td> </tr> <tr> <td>1</td> <td>Timer B is enabled and begins counting or the capture logic is enabled based on the GPTMCFG register.</td> </tr> </tbody> </table>	Value	Description	0	Timer B is disabled.	1	Timer B is enabled and begins counting or the capture logic is enabled based on the GPTMCFG register.				
Value	Description													
0	Timer B is disabled.													
1	Timer B is enabled and begins counting or the capture logic is enabled based on the GPTMCFG register.													
7	reserved	RO	0	Software should not rely on the value of a reserved bit. To provide compatibility with future products, the value of a reserved bit should be preserved across a read-modify-write operation.										
6	TAPWML	RW	0	<p>GPTM Timer A PWM Output Level</p> <p>The TAPWML values are defined as follows:</p> <table border="1"> <thead> <tr> <th>Value</th> <th>Description</th> </tr> </thead> <tbody> <tr> <td>0</td> <td>Output is unaffected.</td> </tr> <tr> <td>1</td> <td>Output is inverted.</td> </tr> </tbody> </table>	Value	Description	0	Output is unaffected.	1	Output is inverted.				
Value	Description													
0	Output is unaffected.													
1	Output is inverted.													

Bit/Field	Name	Type	Reset	Description										
5	TAOTE	RW	0	<p>GPTM Timer A Output Trigger Enable</p> <p>The TAOTE values are defined as follows:</p> <table border="1"> <thead> <tr> <th>Value</th> <th>Description</th> </tr> </thead> <tbody> <tr> <td>0</td> <td>The output Timer A ADC trigger is disabled.</td> </tr> <tr> <td>1</td> <td>The output Timer A ADC trigger is enabled.</td> </tr> </tbody> </table> <p>In addition, the ADC must be enabled and the timer selected as a trigger source with the EMn bit in the ADCEMUX register (see page 1215).</p>	Value	Description	0	The output Timer A ADC trigger is disabled.	1	The output Timer A ADC trigger is enabled.				
Value	Description													
0	The output Timer A ADC trigger is disabled.													
1	The output Timer A ADC trigger is enabled.													
4	RTCEN	RW	0	<p>GPTM RTC Stall Enable</p> <p>The RTCEN values are defined as follows:</p> <table border="1"> <thead> <tr> <th>Value</th> <th>Description</th> </tr> </thead> <tbody> <tr> <td>0</td> <td>RTC counting freezes while the processor is halted by the debugger.</td> </tr> <tr> <td>1</td> <td>RTC counting continues while the processor is halted by the debugger.</td> </tr> </tbody> </table> <p>If the RTCEN bit is set, it prevents the timer from stalling in all operating modes, even if TnSTALL is set.</p>	Value	Description	0	RTC counting freezes while the processor is halted by the debugger.	1	RTC counting continues while the processor is halted by the debugger.				
Value	Description													
0	RTC counting freezes while the processor is halted by the debugger.													
1	RTC counting continues while the processor is halted by the debugger.													
3:2	TAEVENT	RW	0x0	<p>GPTM Timer A Event Mode</p> <p>The TAEVENT values are defined as follows:</p> <table border="1"> <thead> <tr> <th>Value</th> <th>Description</th> </tr> </thead> <tbody> <tr> <td>0x0</td> <td>Positive edge</td> </tr> <tr> <td>0x1</td> <td>Negative edge</td> </tr> <tr> <td>0x2</td> <td>Reserved</td> </tr> <tr> <td>0x3</td> <td>Both edges</td> </tr> </tbody> </table> <p>Note: If PWM output inversion is enabled, edge detection interrupt behavior is reversed. Thus, if a positive-edge interrupt trigger has been set and the PWM inversion generates a positive edge, no event-trigger interrupt asserts. Instead, the interrupt is generated on the negative edge of the PWM signal.</p>	Value	Description	0x0	Positive edge	0x1	Negative edge	0x2	Reserved	0x3	Both edges
Value	Description													
0x0	Positive edge													
0x1	Negative edge													
0x2	Reserved													
0x3	Both edges													
1	TASTALL	RW	0	<p>GPTM Timer A Stall Enable</p> <p>The TASTALL values are defined as follows:</p> <table border="1"> <thead> <tr> <th>Value</th> <th>Description</th> </tr> </thead> <tbody> <tr> <td>0</td> <td>Timer A continues counting while the processor is halted by the debugger.</td> </tr> <tr> <td>1</td> <td>Timer A freezes counting while the processor is halted by the debugger.</td> </tr> </tbody> </table> <p>If the processor is executing normally, the TASTALL bit is ignored.</p>	Value	Description	0	Timer A continues counting while the processor is halted by the debugger.	1	Timer A freezes counting while the processor is halted by the debugger.				
Value	Description													
0	Timer A continues counting while the processor is halted by the debugger.													
1	Timer A freezes counting while the processor is halted by the debugger.													

Bit/Field	Name	Type	Reset	Description
0	TAEN	RW	0	GPTM Timer A Enable The TAEN values are defined as follows: Value Description 0 Timer A is disabled. 1 Timer A is enabled and begins counting or the capture logic is enabled based on the GPTMCFG register.

Register 5: GPTM Synchronize (GPTMSYNC), offset 0x010

Note: This register is only implemented on GPTM Module 0 only.

This register allows software to synchronize a number of timers.

GPTM Synchronize (GPTMSYNC)

16/32-bit Timer 0 base: 0x4003.0000
 16/32-bit Timer 1 base: 0x4003.1000
 16/32-bit Timer 2 base: 0x4003.2000
 16/32-bit Timer 3 base: 0x4003.3000
 16/32-bit Timer 4 base: 0x4003.4000
 16/32-bit Timer 5 base: 0x4003.5000
 16/32-bit Timer 6 base: 0x400E.0000
 16/32-bit Timer 7 base: 0x400E.1000
 Offset 0x010
 Type RW, reset 0x0000.0000

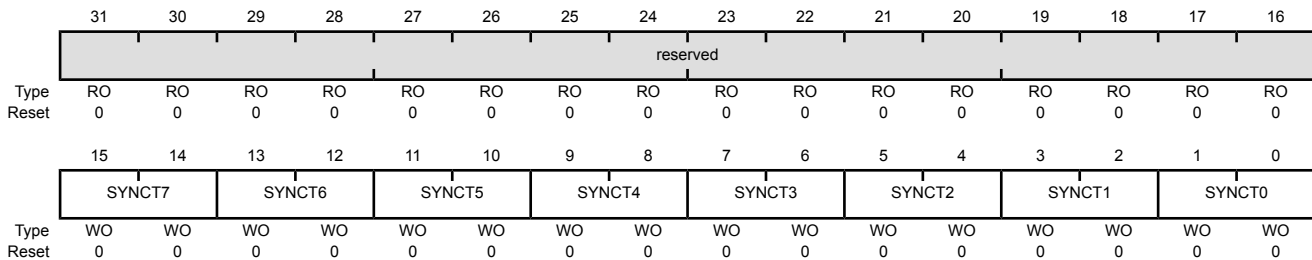

Bit/Field	Name	Type	Reset	Description
31:16	reserved	RO	0x00	Software should not rely on the value of a reserved bit. To provide compatibility with future products, the value of a reserved bit should be preserved across a read-modify-write operation.
15:14	SYNCT7	WO	0x0	Synchronize GPTM Timer 7 Value Description 0x0 GPT7 is not affected. 0x1 A timeout event for Timer A of GPTM7 is triggered. 0x2 A timeout event for Timer B of GPTM7 is triggered. 0x3 A timeout event for both Timer A and Timer B of GPTM7 is triggered.
13:12	SYNCT6	WO	0x0	Synchronize GPTM Timer 6 Value Description 0x0 GPTM6 is not affected. 0x1 A timeout event for Timer A of GPTM6 is triggered. 0x2 A timeout event for Timer B of GPTM6 is triggered. 0x3 A timeout event for both Timer A and Timer B of GPTM6 is triggered.

Bit/Field	Name	Type	Reset	Description
11:10	SYNCT5	WO	0x0	Synchronize GPTM Timer 5 Value Description 0x0 GPTM5 is not affected. 0x1 A timeout event for Timer A of GPTM5 is triggered. 0x2 A timeout event for Timer B of GPTM5 is triggered. 0x3 A timeout event for both Timer A and Timer B of GPTM5 is triggered.
9:8	SYNCT4	WO	0x0	Synchronize GPTM Timer 4 Value Description 0x0 GPTM4 is not affected. 0x1 A timeout event for Timer A of GPTM4 is triggered. 0x2 A timeout event for Timer B of GPTM4 is triggered. 0x3 A timeout event for both Timer A and Timer B of GPTM4 is triggered.
7:6	SYNCT3	WO	0x0	Synchronize GPTM Timer 3 Value Description 0x0 GPTM3 is not affected. 0x1 A timeout event for Timer A of GPTM3 is triggered. 0x2 A timeout event for Timer B of GPTM3 is triggered. 0x3 A timeout event for both Timer A and Timer B of GPTM3 is triggered.
5:4	SYNCT2	WO	0x0	Synchronize GPTM Timer 2 Value Description 0x0 GPTM2 is not affected. 0x1 A timeout event for Timer A of GPTM2 is triggered. 0x2 A timeout event for Timer B of GPTM2 is triggered. 0x3 A timeout event for both Timer A and Timer B of GPTM2 is triggered.
3:2	SYNCT1	WO	0x0	Synchronize GPTM Timer 1 Value Description 0x0 GPTM1 is not affected. 0x1 A timeout event for Timer A of GPTM1 is triggered. 0x2 A timeout event for Timer B of GPTM1 is triggered. 0x3 A timeout event for both Timer A and Timer B of GPTM1 is triggered.

Bit/Field	Name	Type	Reset	Description
1:0	SYNCT0	WO	0x0	Synchronize GPTM Timer 0
				Value Description
				0x0 GPTM0 is not affected.
				0x1 A timeout event for Timer A of GPTM0 is triggered.
				0x2 A timeout event for Timer B of GPTM0 is triggered.
				0x3 A timeout event for both Timer A and Timer B of GPTM0 is triggered.

Register 6: GPTM Interrupt Mask (GPTMIMR), offset 0x018

This register allows software to enable/disable GPTM controller-level interrupts. Setting a bit enables the corresponding interrupt, while clearing a bit disables it.

GPTM Interrupt Mask (GPTMIMR)

16/32-bit Timer 0 base: 0x4003.0000
 16/32-bit Timer 1 base: 0x4003.1000
 16/32-bit Timer 2 base: 0x4003.2000
 16/32-bit Timer 3 base: 0x4003.3000
 16/32-bit Timer 4 base: 0x4003.4000
 16/32-bit Timer 5 base: 0x4003.5000
 16/32-bit Timer 6 base: 0x400E.0000
 16/32-bit Timer 7 base: 0x400E.1000
 Offset 0x018
 Type RW, reset 0x0000.0000

	31	30	29	28	27	26	25	24	23	22	21	20	19	18	17	16
	reserved															
Type	RO	RO	RO	RO	RO	RO	RO	RO	RO	RO	RO	RO	RO	RO	RO	RO
Reset	0	0	0	0	0	0	0	0	0	0	0	0	0	0	0	0
	15	14	13	12	11	10	9	8	7	6	5	4	3	2	1	0
	reserved		DMABIM	reserved	TBMIM	CBEIM	CBMIM	TBTOIM	reserved		DMAAIM	TAMIM	RTCIM	CAEIM	CAMIM	TATOIM
Type	RO	RO	RW	RO	RW	RW	RW	RW	RO	RO	RW	RW	RW	RW	RW	RW
Reset	0	0	0	0	0	0	0	0	0	0	0	0	0	0	0	0

Bit/Field	Name	Type	Reset	Description
31:14	reserved	RO	0x0000	Software should not rely on the value of a reserved bit. To provide compatibility with future products, the value of a reserved bit should be preserved across a read-modify-write operation.
13	DMABIM	RW	0	GPTM Timer B DMA Done Interrupt Mask The DMABIM values are defined as follows: Value Description 0 Interrupt is disabled. 1 Interrupt is enabled.
12	reserved	RO	0x0	Software should not rely on the value of a reserved bit. To provide compatibility with future products, the value of a reserved bit should be preserved across a read-modify-write operation.
11	TBMIM	RW	0	GPTM Timer B Match Interrupt Mask The TBMIM values are defined as follows: Value Description 0 Interrupt is disabled. 1 Interrupt is enabled.
10	CBEIM	RW	0	GPTM Timer B Capture Mode Event Interrupt Mask The CBEIM values are defined as follows: Value Description 0 Interrupt is disabled. 1 Interrupt is enabled.

Bit/Field	Name	Type	Reset	Description
9	CBMIM	RW	0	GPTM Timer B Capture Mode Match Interrupt Mask The CBMIM values are defined as follows: Value Description 0 Interrupt is disabled. 1 Interrupt is enabled.
8	TBTOIM	RW	0	GPTM Timer B Time-Out Interrupt Mask The TBTOIM values are defined as follows: Value Description 0 Interrupt is disabled. 1 Interrupt is enabled.
7:6	reserved	RO	0	Software should not rely on the value of a reserved bit. To provide compatibility with future products, the value of a reserved bit should be preserved across a read-modify-write operation.
5	DMAAIM	RW	0	GPTM Timer A DMA Done Interrupt Mask The DMAAIM values are defined as follows: Value Description 0 Interrupt is disabled. 1 Interrupt is enabled.
4	TAMIM	RW	0	GPTM Timer A Match Interrupt Mask The TAMIM values are defined as follows: Value Description 0 Interrupt is disabled. 1 Interrupt is enabled.
3	RTCIM	RW	0	GPTM RTC Interrupt Mask The RTCIM values are defined as follows: Value Description 0 Interrupt is disabled. 1 Interrupt is enabled.
2	CAEIM	RW	0	GPTM Timer A Capture Mode Event Interrupt Mask The CAEIM values are defined as follows: Value Description 0 Interrupt is disabled. 1 Interrupt is enabled.

Bit/Field	Name	Type	Reset	Description
1	CAMIM	RW	0	GPTM Timer A Capture Mode Match Interrupt Mask The CAMIM values are defined as follows: Value Description 0 Interrupt is disabled. 1 Interrupt is enabled.
0	TATOIM	RW	0	GPTM Timer A Time-Out Interrupt Mask The TATOIM values are defined as follows: Value Description 0 Interrupt is disabled. 1 Interrupt is enabled.

Register 7: GPTM Raw Interrupt Status (GPTMRIS), offset 0x01C

This register shows the state of the GPTM's internal interrupt signal. These bits are set whether or not the interrupt is masked in the **GPTMIMR** register. Each bit can be cleared by writing a 1 to its corresponding bit in **GPTMICR**.

Note: The state of the **GPTMRIS** register is not affected by disabling and then re-enabling the timer using the **TnEN** bits in the **GPTM Control (GPTMCTL)** register. If an application requires that all or certain status bits should not carry over after re-enabling the timer, then the appropriate bits in the **GPTMRIS** register should be cleared using the **GPTMICR** register prior to re-enabling the timer. If this is not done, any status bits set in the **GPTMRIS** register and unmasked in the **GPTMIMR** register generate an interrupt once the timer is re-enabled.

GPTM Raw Interrupt Status (GPTMRIS)

16/32-bit Timer 0 base: 0x4003.0000
 16/32-bit Timer 1 base: 0x4003.1000
 16/32-bit Timer 2 base: 0x4003.2000
 16/32-bit Timer 3 base: 0x4003.3000
 16/32-bit Timer 4 base: 0x4003.4000
 16/32-bit Timer 5 base: 0x4003.5000
 16/32-bit Timer 6 base: 0x400E.0000
 16/32-bit Timer 7 base: 0x400E.1000
 Offset 0x01C
 Type RO, reset 0x0000.0000

	31	30	29	28	27	26	25	24	23	22	21	20	19	18	17	16
	reserved															
Type	RO	RO	RO	RO	RO	RO	RO	RO	RO	RO	RO	RO	RO	RO	RO	RO
Reset	0	0	0	0	0	0	0	0	0	0	0	0	0	0	0	0
	15	14	13	12	11	10	9	8	7	6	5	4	3	2	1	0
	reserved		DMABRIS	reserved	TBRIS	CBERIS	CBMRIS	TBTORIS	reserved		DMAARIS	TAMRIS	RTCRIS	CAERIS	CAMRIS	TATORIS
Type	RO	RO	RO	RO	RO	RO	RO	RO	RO	RO	RO	RO	RO	RO	RO	RO
Reset	0	0	0	0	0	0	0	0	0	0	0	0	0	0	0	0

Bit/Field	Name	Type	Reset	Description
31:14	reserved	RO	0x0000	Software should not rely on the value of a reserved bit. To provide compatibility with future products, the value of a reserved bit should be preserved across a read-modify-write operation.
13	DMABRIS	RO	0	GPTM Timer B DMA Done Raw Interrupt Status Value Description 0 The Timer B DMA transfer has not completed. 1 The Timer B DMA transfer has completed.
12	reserved	RO	0x0	Software should not rely on the value of a reserved bit. To provide compatibility with future products, the value of a reserved bit should be preserved across a read-modify-write operation.

Bit/Field	Name	Type	Reset	Description
11	TBMRIS	RO	0	<p>GPTM Timer B Match Raw Interrupt</p> <p>Value Description</p> <p>0 The match value has not been reached.</p> <p>1 The TBMIE bit is set in the GPTMTBMR register, and the match values in the GPTMTBMATCHR and (optionally) GPTMTBPMR registers have been reached when configured in one-shot or periodic mode.</p> <p>This bit is cleared by writing a 1 to the TBMCINT bit in the GPTMICR register.</p>
10	CBERIS	RO	0	<p>GPTM Timer B Capture Mode Event Raw Interrupt</p> <p>Value Description</p> <p>0 The capture mode event for Timer B has not occurred.</p> <p>1 A capture mode event has occurred for Timer B. This interrupt asserts when the subtimer is configured in Input Edge-Time mode.</p> <p>This bit is cleared by writing a 1 to the CBECINT bit in the GPTMICR register.</p>
9	CBMRIS	RO	0	<p>GPTM Timer B Capture Mode Match Raw Interrupt</p> <p>Value Description</p> <p>0 The capture mode match for Timer B has not occurred.</p> <p>1 The capture mode match has occurred for Timer B. This interrupt asserts when the values in the GPTMTBR and GPTMTBPR match the values in the GPTMTBMATCHR and GPTMTBPMR when configured in Input Edge-Time mode.</p> <p>This bit is cleared by writing a 1 to the CBMCINT bit in the GPTMICR register.</p>
8	TBTORIS	RO	0	<p>GPTM Timer B Time-Out Raw Interrupt</p> <p>Value Description</p> <p>0 Timer B has not timed out.</p> <p>1 Timer B has timed out. This interrupt is asserted when a one-shot or periodic mode timer reaches its count limit (0 or the value loaded into GPTMTBILR, depending on the count direction).</p> <p>This bit is cleared by writing a 1 to the TBTOCINT bit in the GPTMICR register.</p>
7:6	reserved	RO	0	Software should not rely on the value of a reserved bit. To provide compatibility with future products, the value of a reserved bit should be preserved across a read-modify-write operation.
5	DMAARIS	RO	0	<p>GPTM Timer A DMA Done Raw Interrupt Status</p> <p>Value Description</p> <p>0 The Timer A DMA transfer has not completed.</p> <p>1 The Timer A DMA transfer has completed.</p>

Bit/Field	Name	Type	Reset	Description
4	TAMRIS	RO	0	<p>GPTM Timer A Match Raw Interrupt</p> <p>Value Description</p> <p>0 The match value has not been reached.</p> <p>1 The TAMIE bit is set in the GPTMTAMR register, and the match value in the GPTMTAMATCHR and (optionally) GPTMTAPMR registers have been reached when configured in one-shot or periodic mode.</p> <p>This bit is cleared by writing a 1 to the TAMCINT bit in the GPTMICR register.</p>
3	RTCRIS	RO	0	<p>GPTM RTC Raw Interrupt</p> <p>Value Description</p> <p>0 The RTC event has not occurred.</p> <p>1 The RTC event has occurred.</p> <p>This bit is cleared by writing a 1 to the RTCCINT bit in the GPTMICR register.</p>
2	CAERIS	RO	0	<p>GPTM Timer A Capture Mode Event Raw Interrupt</p> <p>Value Description</p> <p>0 The capture mode event for Timer A has not occurred.</p> <p>1 A capture mode event has occurred for Timer A. This interrupt asserts when the subtimer is configured in Input Edge-Time mode.</p> <p>This bit is cleared by writing a 1 to the CAECINT bit in the GPTMICR register.</p>
1	CAMRIS	RO	0	<p>GPTM Timer A Capture Mode Match Raw Interrupt</p> <p>Value Description</p> <p>0 The capture mode match for Timer A has not occurred.</p> <p>1 A capture mode match has occurred for Timer A. This interrupt asserts when the values in the GPTMTAR and GPTMTAPR match the values in the GPTMTAMATCHR and GPTMTAPMR when configured in Input Edge-Time mode.</p> <p>This bit is cleared by writing a 1 to the CAMCINT bit in the GPTMICR register.</p>
0	TATORIS	RO	0	<p>GPTM Timer A Time-Out Raw Interrupt</p> <p>Value Description</p> <p>0 Timer A has not timed out.</p> <p>1 Timer A has timed out. This interrupt is asserted when a one-shot or periodic mode timer reaches its count limit (0 or the value loaded into GPTMTAILR, depending on the count direction).</p> <p>This bit is cleared by writing a 1 to the TATOCINT bit in the GPTMICR register.</p>

Register 8: GPTM Masked Interrupt Status (GPTMMIS), offset 0x020

This register show the state of the GPTM's controller-level interrupt. If an interrupt is unmasked in **GPTMIMR**, and there is an event that causes the interrupt to be asserted, the corresponding bit is set in this register. All bits are cleared by writing a 1 to the corresponding bit in **GPTMICR**.

GPTM Masked Interrupt Status (GPTMMIS)

16/32-bit Timer 0 base: 0x4003.0000
 16/32-bit Timer 1 base: 0x4003.1000
 16/32-bit Timer 2 base: 0x4003.2000
 16/32-bit Timer 3 base: 0x4003.3000
 16/32-bit Timer 4 base: 0x4003.4000
 16/32-bit Timer 5 base: 0x4003.5000
 16/32-bit Timer 6 base: 0x400E.0000
 16/32-bit Timer 7 base: 0x400E.1000
 Offset 0x020
 Type RO, reset 0x0000.0000

	31	30	29	28	27	26	25	24	23	22	21	20	19	18	17	16
	reserved															
Type	RO	RO	RO	RO	RO	RO	RO	RO	RO	RO	RO	RO	RO	RO	RO	RO
Reset	0	0	0	0	0	0	0	0	0	0	0	0	0	0	0	0
	15	14	13	12	11	10	9	8	7	6	5	4	3	2	1	0
	reserved	DMABMIS	reserved	TBMMIS	CBEMIS	CBMMIS	TBTOMIS	reserved	DMAAMIS	TAMMIS	RTCMIS	CAEMIS	CAMMIS	TATOMIS		
Type	RO	RO	RO	RO	RO	RO	RO	RO	RO	RO	RO	RO	RO	RO	RO	RO
Reset	0	0	0	0	0	0	0	0	0	0	0	0	0	0	0	0

Bit/Field	Name	Type	Reset	Description
31:14	reserved	RO	0x0000	Software should not rely on the value of a reserved bit. To provide compatibility with future products, the value of a reserved bit should be preserved across a read-modify-write operation.
13	DMABMIS	RO	0	GPTM Timer B DMA Done Masked Interrupt Value Description 0 A Timer B DMA done interrupt has not occurred or is masked. 1 An unmasked Timer B DMA done interrupt has occurred. This bit is cleared by writing a 1 to the <code>DMABINT</code> bit in the GPTMICR register.
12	reserved	RO	0x0	Software should not rely on the value of a reserved bit. To provide compatibility with future products, the value of a reserved bit should be preserved across a read-modify-write operation.
11	TBMMIS	RO	0	GPTM Timer B Match Masked Interrupt Value Description 0 A Timer B Mode Match interrupt has not occurred or is masked. 1 An unmasked Timer B Mode Match interrupt has occurred. This bit is cleared by writing a 1 to the <code>TBMCINT</code> bit in the GPTMICR register.

Bit/Field	Name	Type	Reset	Description
10	CBEMIS	RO	0	<p>GPTM Timer B Capture Mode Event Masked Interrupt</p> <p>Value Description</p> <p>0 A Capture B event interrupt has not occurred or is masked.</p> <p>1 An unmasked Capture B event interrupt has occurred.</p> <p>This bit is cleared by writing a 1 to the <code>CBECINT</code> bit in the GPTMICR register.</p>
9	CBMMIS	RO	0	<p>GPTM Timer B Capture Mode Match Masked Interrupt</p> <p>Value Description</p> <p>0 A Capture B Mode Match interrupt has not occurred or is masked.</p> <p>1 An unmasked Capture B Match interrupt has occurred.</p> <p>This bit is cleared by writing a 1 to the <code>CBMCINT</code> bit in the GPTMICR register.</p>
8	TBTOMIS	RO	0	<p>GPTM Timer B Time-Out Masked Interrupt</p> <p>Value Description</p> <p>0 A Timer B Time-Out interrupt has not occurred or is masked.</p> <p>1 An unmasked Timer B Time-Out interrupt has occurred.</p> <p>This bit is cleared by writing a 1 to the <code>TBTOCINT</code> bit in the GPTMICR register.</p>
7:6	reserved	RO	0	Software should not rely on the value of a reserved bit. To provide compatibility with future products, the value of a reserved bit should be preserved across a read-modify-write operation.
5	DMAAMIS	RO	0	<p>GPTM Timer A DMA Done Masked Interrupt</p> <p>Value Description</p> <p>0 A Timer A DMA done interrupt has not occurred or is masked.</p> <p>1 An unmasked Timer A DMA done interrupt has occurred.</p> <p>This bit is cleared by writing a 1 to the <code>DMAAINT</code> bit in the GPTMICR register.</p>
4	TAMMIS	RO	0	<p>GPTM Timer A Match Masked Interrupt</p> <p>Value Description</p> <p>0 A Timer A Mode Match interrupt has not occurred or is masked.</p> <p>1 An unmasked Timer A Mode Match interrupt has occurred.</p> <p>This bit is cleared by writing a 1 to the <code>TAMCINT</code> bit in the GPTMICR register.</p>

Bit/Field	Name	Type	Reset	Description
3	RTCMIS	RO	0	<p>GPTM RTC Masked Interrupt</p> <p>Value Description</p> <p>0 An RTC event interrupt has not occurred or is masked.</p> <p>1 An unmasked RTC event interrupt has occurred.</p> <p>This bit is cleared by writing a 1 to the <code>RTCCINT</code> bit in the GPTMICR register.</p>
2	CAEMIS	RO	0	<p>GPTM Timer A Capture Mode Event Masked Interrupt</p> <p>Value Description</p> <p>0 A Capture A event interrupt has not occurred or is masked.</p> <p>1 An unmasked Capture A event interrupt has occurred.</p> <p>This bit is cleared by writing a 1 to the <code>CAECINT</code> bit in the GPTMICR register.</p>
1	CAMMIS	RO	0	<p>GPTM Timer A Capture Mode Match Masked Interrupt</p> <p>Value Description</p> <p>0 A Capture A Mode Match interrupt has not occurred or is masked.</p> <p>1 An unmasked Capture A Match interrupt has occurred.</p> <p>This bit is cleared by writing a 1 to the <code>CAMCINT</code> bit in the GPTMICR register.</p>
0	TATOMIS	RO	0	<p>GPTM Timer A Time-Out Masked Interrupt</p> <p>Value Description</p> <p>0 A Timer A Time-Out interrupt has not occurred or is masked.</p> <p>1 An unmasked Timer A Time-Out interrupt has occurred.</p> <p>This bit is cleared by writing a 1 to the <code>TATOCINT</code> bit in the GPTMICR register.</p>

Register 9: GPTM Interrupt Clear (GPTMICR), offset 0x024

This register is used to clear the status bits in the **GPTMRIS** and **GPTMMIS** registers. Writing a 1 to a bit clears the corresponding bit in the **GPTMRIS** and **GPTMMIS** registers.

GPTM Interrupt Clear (GPTMICR)

16/32-bit Timer 0 base: 0x4003.0000
 16/32-bit Timer 1 base: 0x4003.1000
 16/32-bit Timer 2 base: 0x4003.2000
 16/32-bit Timer 3 base: 0x4003.3000
 16/32-bit Timer 4 base: 0x4003.4000
 16/32-bit Timer 5 base: 0x4003.5000
 16/32-bit Timer 6 base: 0x400E.0000
 16/32-bit Timer 7 base: 0x400E.1000
 Offset 0x024
 Type W1C, reset 0x0000.0000

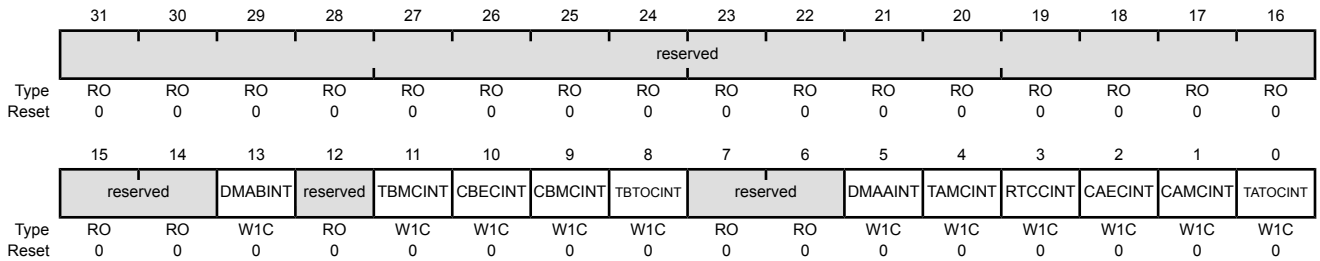

Bit/Field	Name	Type	Reset	Description
31:14	reserved	RO	0x0000	Software should not rely on the value of a reserved bit. To provide compatibility with future products, the value of a reserved bit should be preserved across a read-modify-write operation.
13	DMABINT	W1C	0	GPTM Timer B DMA Done Interrupt Clear Writing a 1 to this bit clears the DMABRIS bit in the GPTMRIS register and the DMABMIS bit in the GPTMMIS register.
12	reserved	RO	0x0	Software should not rely on the value of a reserved bit. To provide compatibility with future products, the value of a reserved bit should be preserved across a read-modify-write operation.
11	TBMCINT	W1C	0	GPTM Timer B Match Interrupt Clear Writing a 1 to this bit clears the TBMRIS bit in the GPTMRIS register and the TBMMIS bit in the GPTMMIS register.
10	CBECINT	W1C	0	GPTM Timer B Capture Mode Event Interrupt Clear Writing a 1 to this bit clears the CBERIS bit in the GPTMRIS register and the CBEMIS bit in the GPTMMIS register.
9	CBMCINT	W1C	0	GPTM Timer B Capture Mode Match Interrupt Clear Writing a 1 to this bit clears the CBMRIS bit in the GPTMRIS register and the CBMMIS bit in the GPTMMIS register.
8	TBTOCINT	W1C	0	GPTM Timer B Time-Out Interrupt Clear Writing a 1 to this bit clears the TBTORIS bit in the GPTMRIS register and the TBTOMIS bit in the GPTMMIS register.
7:6	reserved	RO	0	Software should not rely on the value of a reserved bit. To provide compatibility with future products, the value of a reserved bit should be preserved across a read-modify-write operation.

Bit/Field	Name	Type	Reset	Description
5	DMAAINT	W1C	0	GPTM Timer A DMA Done Interrupt Clear Writing a 1 to this bit clears the DMAARIS bit in the GPTMRIS register and the DMAAMIS bit in the GPTMMIS register.
4	TAMCINT	W1C	0	GPTM Timer A Match Interrupt Clear Writing a 1 to this bit clears the TAMRIS bit in the GPTMRIS register and the TAMMIS bit in the GPTMMIS register.
3	RTCCINT	W1C	0	GPTM RTC Interrupt Clear Writing a 1 to this bit clears the RTCRIS bit in the GPTMRIS register and the RTCMIS bit in the GPTMMIS register.
2	CAECINT	W1C	0	GPTM Timer A Capture Mode Event Interrupt Clear Writing a 1 to this bit clears the CAERIS bit in the GPTMRIS register and the CAEMIS bit in the GPTMMIS register.
1	CAMCINT	W1C	0	GPTM Timer A Capture Mode Match Interrupt Clear Writing a 1 to this bit clears the CAMRIS bit in the GPTMRIS register and the CAMMIS bit in the GPTMMIS register.
0	TATOCINT	W1C	0	GPTM Timer A Time-Out Raw Interrupt Writing a 1 to this bit clears the TATORIS bit in the GPTMRIS register and the TATOMIS bit in the GPTMMIS register.

Register 10: GPTM Timer A Interval Load (GPTMTAILR), offset 0x028

When the timer is counting down, this register is used to load the starting count value into the timer. When the timer is counting up, this register sets the upper bound for the timeout event.

When a GPTM is configured to one of the 32-bit modes, **GPTMTAILR** appears as a 32-bit register (the upper 16-bits correspond to the contents of the **GPTM Timer B Interval Load (GPTMTBILR)** register). In a 16-bit mode, the upper 16 bits of this register read as 0s and have no effect on the state of **GPTMTBILR**.

GPTM Timer A Interval Load (GPTMTAILR)

16/32-bit Timer 0 base: 0x4003.0000
 16/32-bit Timer 1 base: 0x4003.1000
 16/32-bit Timer 2 base: 0x4003.2000
 16/32-bit Timer 3 base: 0x4003.3000
 16/32-bit Timer 4 base: 0x4003.4000
 16/32-bit Timer 5 base: 0x4003.5000
 16/32-bit Timer 6 base: 0x400E.0000
 16/32-bit Timer 7 base: 0x400E.1000
 Offset 0x028
 Type RW, reset 0xFFFF.FFFF

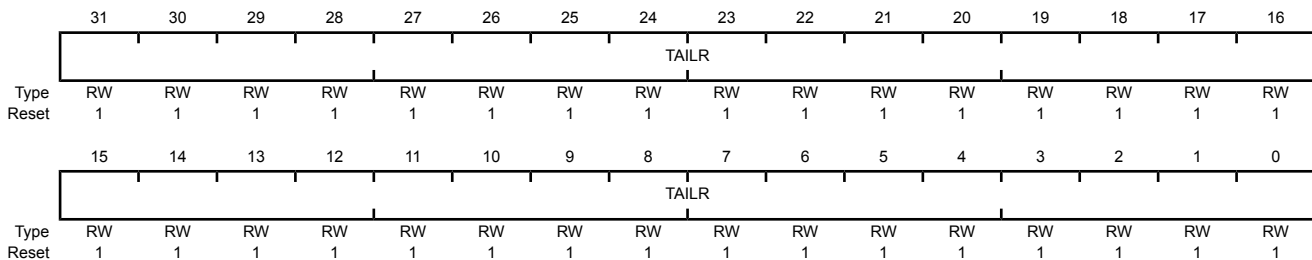

Bit/Field	Name	Type	Reset	Description
31:0	TAILR	RW	0xFFFF.FFFF	GPTM Timer A Interval Load Register Writing this field loads the counter for Timer A. A read returns the current value of GPTMTAILR .

Register 11: GPTM Timer B Interval Load (GPTMTBILR), offset 0x02C

When the timer is counting down, this register is used to load the starting count value into the timer. When the timer is counting up, this register sets the upper bound for the timeout event.

When a GPTM is configured to one of the 32-bit modes, the contents of bits 15:0 in this register are loaded into the upper 16 bits of the **GPTMTAILR** register. Reads from this register return the current value of Timer B and writes are ignored. In a 16-bit mode, bits 15:0 are used for the load value. Bits 31:16 are reserved in both cases.

GPTM Timer B Interval Load (GPTMTBILR)

16/32-bit Timer 0 base: 0x4003.0000
 16/32-bit Timer 1 base: 0x4003.1000
 16/32-bit Timer 2 base: 0x4003.2000
 16/32-bit Timer 3 base: 0x4003.3000
 16/32-bit Timer 4 base: 0x4003.4000
 16/32-bit Timer 5 base: 0x4003.5000
 16/32-bit Timer 6 base: 0x400E.0000
 16/32-bit Timer 7 base: 0x400E.1000
 Offset 0x02C
 Type RW, reset 0x0000.FFFF

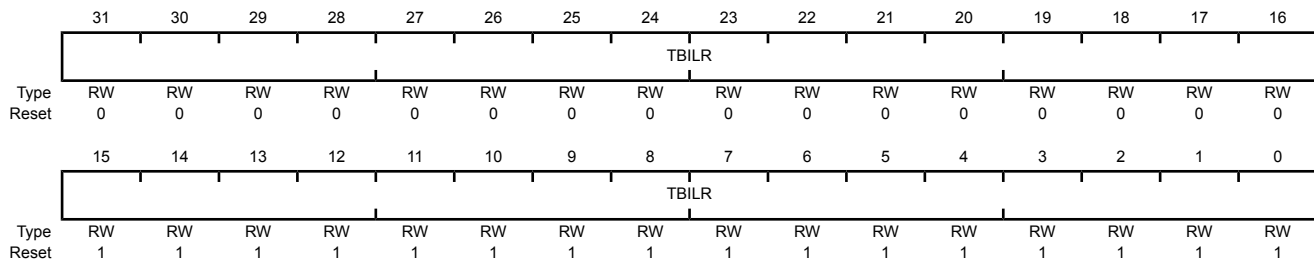

Bit/Field	Name	Type	Reset	Description
31:0	TBILR	RW	0x0000.FFFF	GPTM Timer B Interval Load Register Writing this field loads the counter for Timer B. A read returns the current value of GPTMTBILR . When a 16/32-bit GPTM is in 32-bit mode, writes are ignored, and reads return the current value of GPTMTBILR .

Register 12: GPTM Timer A Match (GPTMTAMATCHR), offset 0x030

This register is loaded with a match value. Interrupts can be generated when the timer value is equal to the value in this register in one-shot or periodic mode.

In Edge-Count mode, this register along with **GPTMTAILR**, determines how many edge events are counted. The total number of edge events counted is equal to the value in **GPTMTAILR** minus this value. Note that in edge-count mode, when executing an up-count, the value of **GPTMTnPR** and **GPTMTnILR** must be greater than the value of **GPTMTnPMR** and **GPTMTnMATCHR**.

In PWM mode, this value along with **GPTMTAILR**, determines the duty cycle of the output PWM signal.

When a 16/32-bit GPTM is configured to one of the 32-bit modes, **GPTMTAMATCHR** appears as a 32-bit register (the upper 16-bits correspond to the contents of the **GPTM Timer B Match (GPTMTBMATCHR)** register). In a 16-bit mode, the upper 16 bits of this register read as 0s and have no effect on the state of **GPTMTBMATCHR**.

GPTM Timer A Match (GPTMTAMATCHR)

16/32-bit Timer 0 base: 0x4003.0000
 16/32-bit Timer 1 base: 0x4003.1000
 16/32-bit Timer 2 base: 0x4003.2000
 16/32-bit Timer 3 base: 0x4003.3000
 16/32-bit Timer 4 base: 0x4003.4000
 16/32-bit Timer 5 base: 0x4003.5000
 16/32-bit Timer 6 base: 0x400E.0000
 16/32-bit Timer 7 base: 0x400E.1000
 Offset 0x030
 Type RW, reset 0xFFFF.FFFF

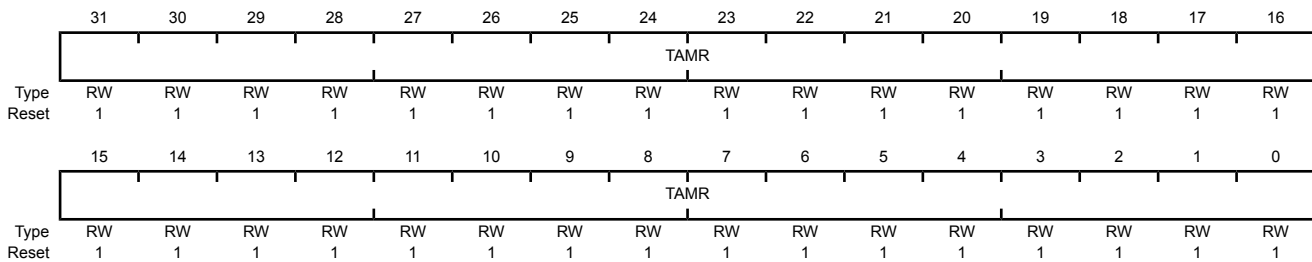

Bit/Field	Name	Type	Reset	Description
31:0	TAMR	RW	0xFFFF.FFFF	GPTM Timer A Match Register This value is compared to the GPTMTAR register to determine match events.

Register 13: GPTM Timer B Match (GPTMTBMATCHR), offset 0x034

This register is loaded with a match value. Interrupts can be generated when the timer value is equal to the value in this register in one-shot or periodic mode.

In Edge-Count mode, this register along with **GPTMTBILR** determines how many edge events are counted. The total number of edge events counted is equal to the value in **GPTMTBILR** minus this value. Note that in edge-count mode, when executing an up-count, the value of **GPTMTnPR** and **GPTMTnILR** must be greater than the value of **GPTMTnPMR** and **GPTMTnMATCHR**.

In PWM mode, this value along with **GPTMTBILR**, determines the duty cycle of the output PWM signal.

When a GPTM is configured to one of the 32-bit modes, the contents of bits 15:0 in this register are loaded into the upper 16 bits of the **GPTMTAMATCHR** register. Reads from this register return the current match value of Timer B and writes are ignored. In a 16-bit mode, bits 15:0 are used for the match value. Bits 31:16 are reserved in both cases.

GPTM Timer B Match (GPTMTBMATCHR)

16/32-bit Timer 0 base: 0x4003.0000
 16/32-bit Timer 1 base: 0x4003.1000
 16/32-bit Timer 2 base: 0x4003.2000
 16/32-bit Timer 3 base: 0x4003.3000
 16/32-bit Timer 4 base: 0x4003.4000
 16/32-bit Timer 5 base: 0x4003.5000
 16/32-bit Timer 6 base: 0x400E.0000
 16/32-bit Timer 7 base: 0x400E.1000
 Offset 0x034

Type RW, reset 0x0000.FFFF

	31	30	29	28	27	26	25	24	23	22	21	20	19	18	17	16
	TBMR															
Type	RW	RW	RW	RW	RW	RW	RW	RW	RW	RW	RW	RW	RW	RW	RW	RW
Reset	0	0	0	0	0	0	0	0	0	0	0	0	0	0	0	0
	15	14	13	12	11	10	9	8	7	6	5	4	3	2	1	0
	TBMR															
Type	RW	RW	RW	RW	RW	RW	RW	RW	RW	RW	RW	RW	RW	RW	RW	RW
Reset	1	1	1	1	1	1	1	1	1	1	1	1	1	1	1	1

Bit/Field	Name	Type	Reset	Description
31:0	TBMR	RW	0x0000.FFFF	GPTM Timer B Match Register This value is compared to the GPTMTBR register to determine match events.

Register 14: GPTM Timer A Prescale (GPTMTAPR), offset 0x038

This register allows software to extend the range of the timers when they are used individually. When in one-shot or periodic down count modes, this register acts as a true prescaler for the timer counter. When acting as a true prescaler, the prescaler counts down to 0 before the value in the **GPTMTAR** and **GPTMTAV** registers are incremented. In all other individual/split modes, this register is a linear extension of the upper range of the timer counter, holding bits 23:16 in the 16-bit modes of the 16/32-bit GPTM.

GPTM Timer A Prescale (GPTMTAPR)

16/32-bit Timer 0 base: 0x4003.0000
 16/32-bit Timer 1 base: 0x4003.1000
 16/32-bit Timer 2 base: 0x4003.2000
 16/32-bit Timer 3 base: 0x4003.3000
 16/32-bit Timer 4 base: 0x4003.4000
 16/32-bit Timer 5 base: 0x4003.5000
 16/32-bit Timer 6 base: 0x400E.0000
 16/32-bit Timer 7 base: 0x400E.1000
 Offset 0x038
 Type RW, reset 0x0000.0000

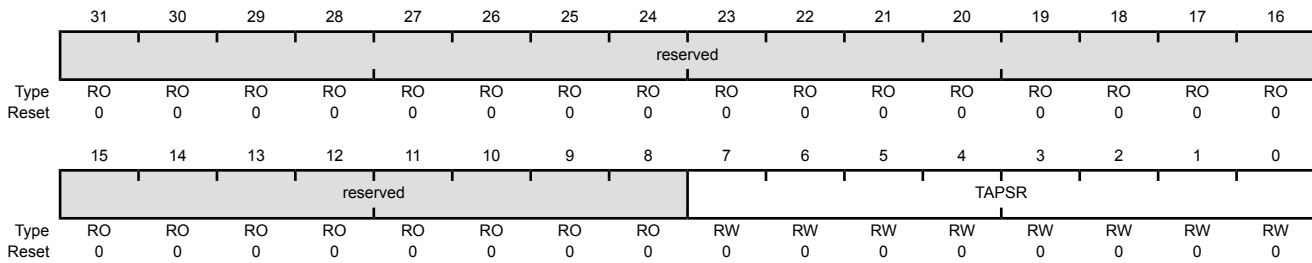

Bit/Field	Name	Type	Reset	Description
31:8	reserved	RO	0	Software should not rely on the value of a reserved bit. To provide compatibility with future products, the value of a reserved bit should be preserved across a read-modify-write operation.
7:0	TAPSR	RW	0x00	GPTM Timer A Prescale The register loads this value on a write. A read returns the current value of the register. For the 16/32-bit GPTM, this field contains the entire 8-bit prescaler. Refer to Table 16-5 on page 1085 for more details and an example.

Register 15: GPTM Timer B Prescale (GPTMTBPR), offset 0x03C

This register allows software to extend the range of the timers when they are used individually. When in one-shot or periodic down count modes, this register acts as a true prescaler for the timer counter. When acting as a true prescaler, the prescaler counts down to 0 before the value in the **GPTMTBR** and **GPTMTBV** registers are incremented. In all other individual/split modes, this register is a linear extension of the upper range of the timer counter, holding bits 23:16 in the 16-bit modes of the 16/32-bit GPTM.

GPTM Timer B Prescale (GPTMTBPR)

16/32-bit Timer 0 base: 0x4003.0000
 16/32-bit Timer 1 base: 0x4003.1000
 16/32-bit Timer 2 base: 0x4003.2000
 16/32-bit Timer 3 base: 0x4003.3000
 16/32-bit Timer 4 base: 0x4003.4000
 16/32-bit Timer 5 base: 0x4003.5000
 16/32-bit Timer 6 base: 0x400E.0000
 16/32-bit Timer 7 base: 0x400E.1000
 Offset 0x03C
 Type RW, reset 0x0000.0000

	31	30	29	28	27	26	25	24	23	22	21	20	19	18	17	16
	reserved															
Type	RO	RO	RO	RO	RO	RO	RO	RO	RO	RO	RO	RO	RO	RO	RO	RO
Reset	0	0	0	0	0	0	0	0	0	0	0	0	0	0	0	0
	15	14	13	12	11	10	9	8	7	6	5	4	3	2	1	0
	reserved								TBPSR							
Type	RO	RO	RO	RO	RO	RO	RO	RO	RW	RW	RW	RW	RW	RW	RW	RW
Reset	0	0	0	0	0	0	0	0	0	0	0	0	0	0	0	0

Bit/Field	Name	Type	Reset	Description
31:8	reserved	RO	0	Software should not rely on the value of a reserved bit. To provide compatibility with future products, the value of a reserved bit should be preserved across a read-modify-write operation.
7:0	TBPSR	RW	0x00	GPTM Timer B Prescale The register loads this value on a write. A read returns the current value of this register. For the 16/32-bit GPTM, this field contains the entire 8-bit prescaler. Refer to Table 16-5 on page 1085 for more details and an example.

Register 16: GPTM TimerA Prescale Match (GPTMTAPMR), offset 0x040

This register allows software to extend the range of the **GPTMTAMATCHR** when the timers are used individually. This register holds bits 23:16 in the 16-bit modes of the 16/32-bit GPTM.

GPTM TimerA Prescale Match (GPTMTAPMR)

16/32-bit Timer 0 base: 0x4003.0000
 16/32-bit Timer 1 base: 0x4003.1000
 16/32-bit Timer 2 base: 0x4003.2000
 16/32-bit Timer 3 base: 0x4003.3000
 16/32-bit Timer 4 base: 0x4003.4000
 16/32-bit Timer 5 base: 0x4003.5000
 16/32-bit Timer 6 base: 0x400E.0000
 16/32-bit Timer 7 base: 0x400E.1000
 Offset 0x040
 Type RW, reset 0x0000.0000

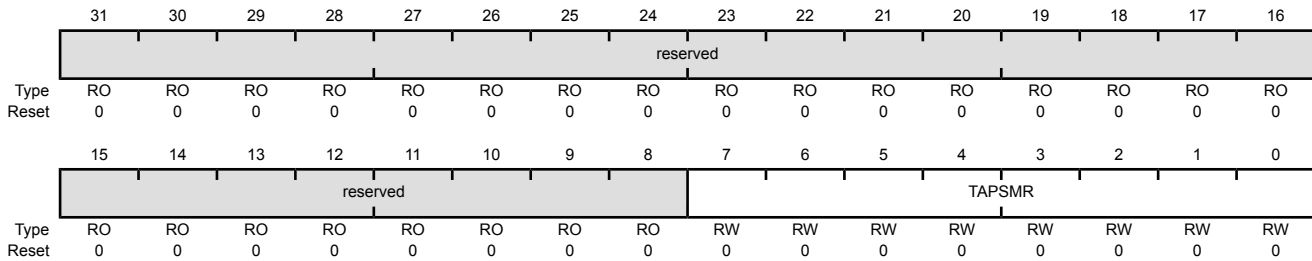

Bit/Field	Name	Type	Reset	Description
31:8	reserved	RO	0x0000	Software should not rely on the value of a reserved bit. To provide compatibility with future products, the value of a reserved bit should be preserved across a read-modify-write operation.
7:0	TAPSMR	RW	0x00	GPTM TimerA Prescale Match This value is used alongside GPTMTAMATCHR to detect timer match events while using a prescaler. For the 16/32-bit GPTM, this field contains the entire 8-bit prescaler match value.

Register 17: GPTM TimerB Prescale Match (GPTMTBPMR), offset 0x044

This register allows software to extend the range of the **GPTMTBMATCHR** when the timers are used individually. This register holds bits 23:16 in the 16-bit modes of the 16/32-bit GPTM.

GPTM TimerB Prescale Match (GPTMTBPMR)

16/32-bit Timer 0 base: 0x4003.0000
 16/32-bit Timer 1 base: 0x4003.1000
 16/32-bit Timer 2 base: 0x4003.2000
 16/32-bit Timer 3 base: 0x4003.3000
 16/32-bit Timer 4 base: 0x4003.4000
 16/32-bit Timer 5 base: 0x4003.5000
 16/32-bit Timer 6 base: 0x400E.0000
 16/32-bit Timer 7 base: 0x400E.1000
 Offset 0x044
 Type RW, reset 0x0000.0000

	31	30	29	28	27	26	25	24	23	22	21	20	19	18	17	16
	reserved															
Type	RO	RO	RO	RO	RO	RO	RO	RO	RO	RO	RO	RO	RO	RO	RO	RO
Reset	0	0	0	0	0	0	0	0	0	0	0	0	0	0	0	0
	15	14	13	12	11	10	9	8	7	6	5	4	3	2	1	0
	reserved								TBPSMR							
Type	RO	RO	RO	RO	RO	RO	RO	RO	RW	RW	RW	RW	RW	RW	RW	RW
Reset	0	0	0	0	0	0	0	0	0	0	0	0	0	0	0	0

Bit/Field	Name	Type	Reset	Description
31:8	reserved	RO	0x0000	Software should not rely on the value of a reserved bit. To provide compatibility with future products, the value of a reserved bit should be preserved across a read-modify-write operation.
7:0	TBPSMR	RW	0x00	GPTM TimerB Prescale Match This value is used alongside GPTMTBMATCHR to detect timer match events while using a prescaler.

Register 18: GPTM Timer A (GPTMTAR), offset 0x048

This register shows the current value of the Timer A counter in all cases except for Input Edge Count and Time modes. In the Input Edge Count mode, this register contains the number of edges that have occurred. In the Input Edge Time mode, this register contains the time at which the last edge event took place.

Note: When an alternate clock source is enabled, a read of this register returns the current count -1.

When a GPTM is configured to one of the 32-bit modes, **GPTMTAR** appears as a 32-bit register (the upper 16-bits correspond to the contents of the **GPTM Timer B (GPTMTBR)** register). In the 16-bit Input Edge Count, Input Edge Time, and PWM modes, bits 15:0 contain the value of the counter and bits 23:16 contain the value of the prescaler, which is the upper 8 bits of the count. Bits 31:24 always read as 0. To read the value of the prescaler in 16-bit One-Shot and Periodic modes, read bits [23:16] in the **GPTMTAV** register. To read the value of the prescaler in periodic snapshot mode, read the **Timer A Prescale Snapshot (GPTMTAPS)** register.

GPTM Timer A (GPTMTAR)

16/32-bit Timer 0 base: 0x4003.0000
 16/32-bit Timer 1 base: 0x4003.1000
 16/32-bit Timer 2 base: 0x4003.2000
 16/32-bit Timer 3 base: 0x4003.3000
 16/32-bit Timer 4 base: 0x4003.4000
 16/32-bit Timer 5 base: 0x4003.5000
 16/32-bit Timer 6 base: 0x400E.0000
 16/32-bit Timer 7 base: 0x400E.1000
 Offset 0x048
 Type RO, reset 0xFFFF.FFFF

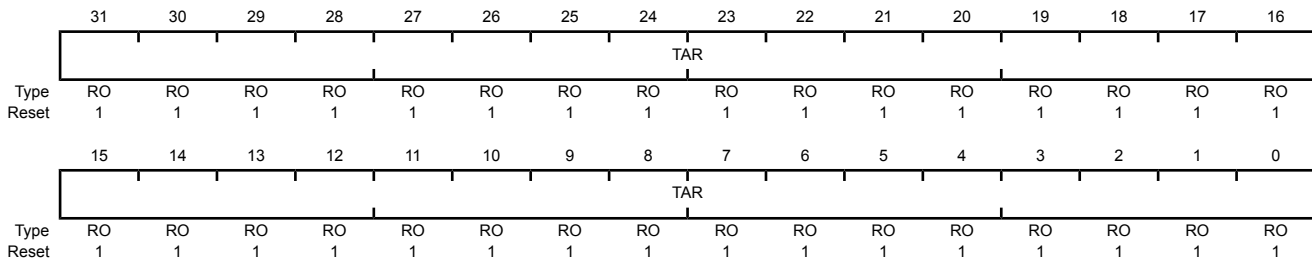

Bit/Field	Name	Type	Reset	Description
31:0	TAR	RO	0xFFFF.FFFF	GPTM Timer A Register

A read returns the current value of the **GPTM Timer A Count Register**, in all cases except for Input Edge Count and Time modes. In the Input Edge Count mode, this register contains the number of edges that have occurred. In the Input Edge Time mode, this register contains the time at which the last edge event took place.

Register 19: GPTM Timer B (GPTMTBR), offset 0x04C

This register shows the current value of the Timer B counter in all cases except for Input Edge Count and Time modes. In the Input Edge Count mode, this register contains the number of edges that have occurred. In the Input Edge Time mode, this register contains the time at which the last edge event took place.

Note: When an alternate clock source is enabled, a read of this register returns the current count -1.

When a GPTM is configured to one of the 32-bit modes, the contents of bits 15:0 in this register are loaded into the upper 16 bits of the **GPTMTAR** register. Reads from this register return the current value of Timer B. In a 16-bit mode, bits 15:0 contain the value of the counter and bits 23:16 contain the value of the prescaler in Input Edge Count, Input Edge Time, and PWM modes, which is the upper 8 bits of the count. Bits 31:24 always read as 0. To read the value of the prescaler in 16-bit One-Shot and Periodic modes, read bits [23:16] in the **GPTMTBV** register. To read the value of the prescaler in periodic snapshot mode, read the **Timer B Prescale Snapshot (GPTMTBPS)** register.

GPTM Timer B (GPTMTBR)

16/32-bit Timer 0 base: 0x4003.0000
 16/32-bit Timer 1 base: 0x4003.1000
 16/32-bit Timer 2 base: 0x4003.2000
 16/32-bit Timer 3 base: 0x4003.3000
 16/32-bit Timer 4 base: 0x4003.4000
 16/32-bit Timer 5 base: 0x4003.5000
 16/32-bit Timer 6 base: 0x400E.0000
 16/32-bit Timer 7 base: 0x400E.1000
 Offset 0x04C
 Type RO, reset 0x0000.FFFF

	31	30	29	28	27	26	25	24	23	22	21	20	19	18	17	16
	TBR															
Type	RO	RO	RO	RO	RO	RO	RO	RO	RO	RO	RO	RO	RO	RO	RO	RO
Reset	0	0	0	0	0	0	0	0	0	0	0	0	0	0	0	0
	15	14	13	12	11	10	9	8	7	6	5	4	3	2	1	0
	TBR															
Type	RO	RO	RO	RO	RO	RO	RO	RO	RO	RO	RO	RO	RO	RO	RO	RO
Reset	1	1	1	1	1	1	1	1	1	1	1	1	1	1	1	1

Bit/Field	Name	Type	Reset	Description
31:0	TBR	RO	0x0000.FFFF	GPTM Timer B Register

A read returns the current value of the **GPTM Timer B Count Register**, in all cases except for Input Edge Count and Time modes. In the Input Edge Count mode, this register contains the number of edges that have occurred. In the Input Edge Time mode, this register contains the time at which the last edge event took place.

Register 20: GPTM Timer A Value (GPTMTAV), offset 0x050

When read, this register shows the current, free-running value of Timer A in all modes. Software can use this value to determine the time elapsed between an interrupt and the ISR entry when using the snapshot feature with the periodic operating mode. When written, the value written into this register is loaded into the **GPTMTAR** register on the next clock cycle.

Note: When an alternate clock source is enabled, a read of this register returns the current count -1.

When a 16/32-bit GPTM is configured to one of the 32-bit modes, **GPTMTAV** appears as a 32-bit register (the upper 16-bits correspond to the contents of the **GPTM Timer B Value (GPTMTBV)** register). In a 16-bit mode, bits 15:0 contain the value of the counter and bits 23:16 contain the current, free-running value of the prescaler, which is the upper 8 bits of the count in Input Edge Count, Input Edge Time, PWM and one-shot or periodic up count modes. In one-shot or periodic down count modes, the prescaler stored in 23:16 is a true prescaler, meaning bits 23:16 count down before decrementing the value in bits 15:0. The prescaler in bits 31:24 always reads as 0.

GPTM Timer A Value (GPTMTAV)

16/32-bit Timer 0 base: 0x4003.0000
 16/32-bit Timer 1 base: 0x4003.1000
 16/32-bit Timer 2 base: 0x4003.2000
 16/32-bit Timer 3 base: 0x4003.3000
 16/32-bit Timer 4 base: 0x4003.4000
 16/32-bit Timer 5 base: 0x4003.5000
 16/32-bit Timer 6 base: 0x400E.0000
 16/32-bit Timer 7 base: 0x400E.1000
 Offset 0x050
 Type RW, reset 0xFFFF.FFFF

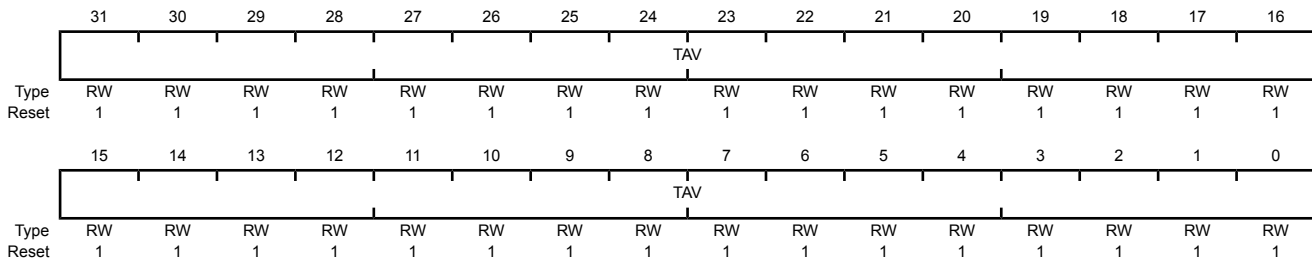

Bit/Field	Name	Type	Reset	Description
31:0	TAV	RW	0xFFFF.FFFF	GPTM Timer A Value

A read returns the current, free-running value of Timer A in all modes. When written, the value written into this register is loaded into the **GPTMTAR** register on the next clock cycle.

Note: In 16-bit mode, only the lower 16-bits of the **GPTMTAV** register can be written with a new value. Writes to the prescaler bits have no effect.

Register 21: GPTM Timer B Value (GPTMTBV), offset 0x054

When read, this register shows the current, free-running value of Timer B in all modes. Software can use this value to determine the time elapsed between an interrupt and the ISR entry. When written, the value written into this register is loaded into the **GPTMTBR** register on the next clock cycle.

Note: When an alternate clock source is enabled, a read of this register returns the current count -1.

When a 16/32-bit GPTM is configured to one of the 32-bit modes, the contents of bits 15:0 in this register are loaded into the upper 16 bits of the **GPTMTAV** register. Reads from this register return the current free-running value of Timer B. In a 16-bit mode, bits 15:0 contain the value of the counter and bits 23:16 contain the current, free-running value of the prescaler, which is the upper 8 bits of the count in Input Edge Count, Input Edge Time, PWM and one-shot or periodic up count modes. In one-shot or periodic down count modes, the prescaler stored in 23:16 is a true prescaler, meaning bits 23:16 count down before decrementing the value in bits 15:0. The prescaler in bits 31:24 always reads as 0.

GPTM Timer B Value (GPTMTBV)

16/32-bit Timer 0 base: 0x4003.0000
 16/32-bit Timer 1 base: 0x4003.1000
 16/32-bit Timer 2 base: 0x4003.2000
 16/32-bit Timer 3 base: 0x4003.3000
 16/32-bit Timer 4 base: 0x4003.4000
 16/32-bit Timer 5 base: 0x4003.5000
 16/32-bit Timer 6 base: 0x400E.0000
 16/32-bit Timer 7 base: 0x400E.1000
 Offset 0x054
 Type RW, reset 0x0000.FFFF

	31	30	29	28	27	26	25	24	23	22	21	20	19	18	17	16
	TBV															
Type	RW	RW	RW	RW	RW	RW	RW	RW	RW	RW	RW	RW	RW	RW	RW	RW
Reset	0	0	0	0	0	0	0	0	0	0	0	0	0	0	0	0
	15	14	13	12	11	10	9	8	7	6	5	4	3	2	1	0
	TBV															
Type	RW	RW	RW	RW	RW	RW	RW	RW	RW	RW	RW	RW	RW	RW	RW	RW
Reset	1	1	1	1	1	1	1	1	1	1	1	1	1	1	1	1

Bit/Field	Name	Type	Reset	Description
31:0	TBV	RW	0x0000.FFFF	GPTM Timer B Value

A read returns the current, free-running value of Timer A in all modes. When written, the value written into this register is loaded into the **GPTMTAR** register on the next clock cycle.

Note: In 16-bit mode, only the lower 16-bits of the **GPTMTBV** register can be written with a new value. Writes to the prescaler bits have no effect.

Register 22: GPTM RTC Predivide (GPTMRTCPD), offset 0x058

This register provides the current RTC predivider value when the timer is operating in RTC mode. Software must perform an atomic access with consecutive reads of the **GPTMTAR**, **GPTMTBR**, and **GPTMRTCPD** registers.

Note: When an alternate clock source is enabled, a read of this register returns the current count -1.

GPTM RTC Predivide (GPTMRTCPD)

16/32-bit Timer 0 base: 0x4003.0000
 16/32-bit Timer 1 base: 0x4003.1000
 16/32-bit Timer 2 base: 0x4003.2000
 16/32-bit Timer 3 base: 0x4003.3000
 16/32-bit Timer 4 base: 0x4003.4000
 16/32-bit Timer 5 base: 0x4003.5000
 16/32-bit Timer 6 base: 0x400E.0000
 16/32-bit Timer 7 base: 0x400E.1000
 Offset 0x058
 Type RO, reset 0x0000.7FFF

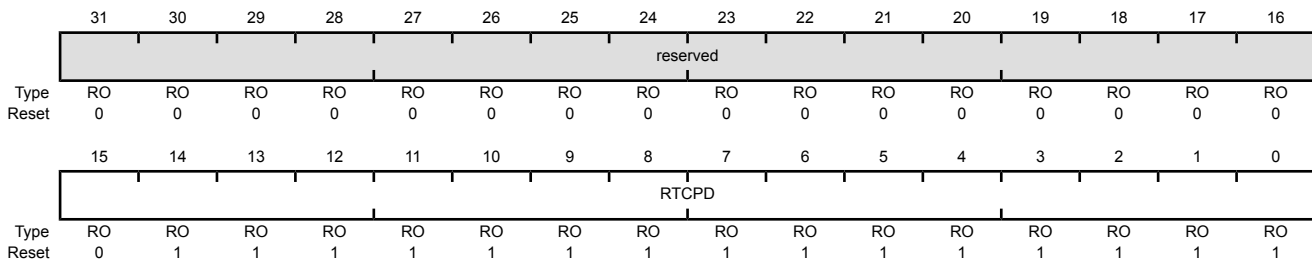

Bit/Field	Name	Type	Reset	Description
31:16	reserved	RO	0x0000	Software should not rely on the value of a reserved bit. To provide compatibility with future products, the value of a reserved bit should be preserved across a read-modify-write operation.
15:0	RTCPD	RO	0x0000.7FFF	RTC Predivide Counter Value The current RTC predivider value when the timer is operating in RTC mode. This field has no meaning in other timer modes.

Register 23: GPTM Timer A Prescale Snapshot (GPTMTAPS), offset 0x05C

For 16-/32-bit wide GPTM, this register shows the current value of the Timer A prescaler for periodic snapshot mode.

GPTM Timer A Prescale Snapshot (GPTMTAPS)

16/32-bit Timer 0 base: 0x4003.0000
 16/32-bit Timer 1 base: 0x4003.1000
 16/32-bit Timer 2 base: 0x4003.2000
 16/32-bit Timer 3 base: 0x4003.3000
 16/32-bit Timer 4 base: 0x4003.4000
 16/32-bit Timer 5 base: 0x4003.5000
 16/32-bit Timer 6 base: 0x400E.0000
 16/32-bit Timer 7 base: 0x400E.1000
 Offset 0x05C
 Type RO, reset 0x0000.0000

	31	30	29	28	27	26	25	24	23	22	21	20	19	18	17	16
	reserved															
Type	RO	RO	RO	RO	RO	RO	RO	RO	RO	RO	RO	RO	RO	RO	RO	RO
Reset	0	0	0	0	0	0	0	0	0	0	0	0	0	0	0	0
	15	14	13	12	11	10	9	8	7	6	5	4	3	2	1	0
	PSS															
Type	RO	RO	RO	RO	RO	RO	RO	RO	RO	RO	RO	RO	RO	RO	RO	RO
Reset	0	0	0	0	0	0	0	0	0	0	0	0	0	0	0	0

Bit/Field	Name	Type	Reset	Description
31:16	reserved	RO	0x0000	Software should not rely on the value of a reserved bit. To provide compatibility with future products, the value of a reserved bit should be preserved across a read-modify-write operation.
15:0	PSS	RO	0x0000	GPTM Timer A Prescaler Snapshot A read returns the current value of the GPTM Timer A Prescaler .

Register 24: GPTM Timer B Prescale Snapshot (GPTMTBPS), offset 0x060

For 16-/32-bit wide GPTM, this register shows the current value of the Timer B prescaler for periodic snapshot mode.

GPTM Timer B Prescale Snapshot (GPTMTBPS)

16/32-bit Timer 0 base: 0x4003.0000
 16/32-bit Timer 1 base: 0x4003.1000
 16/32-bit Timer 2 base: 0x4003.2000
 16/32-bit Timer 3 base: 0x4003.3000
 16/32-bit Timer 4 base: 0x4003.4000
 16/32-bit Timer 5 base: 0x4003.5000
 16/32-bit Timer 6 base: 0x400E.0000
 16/32-bit Timer 7 base: 0x400E.1000
 Offset 0x060
 Type RO, reset 0x0000.0000

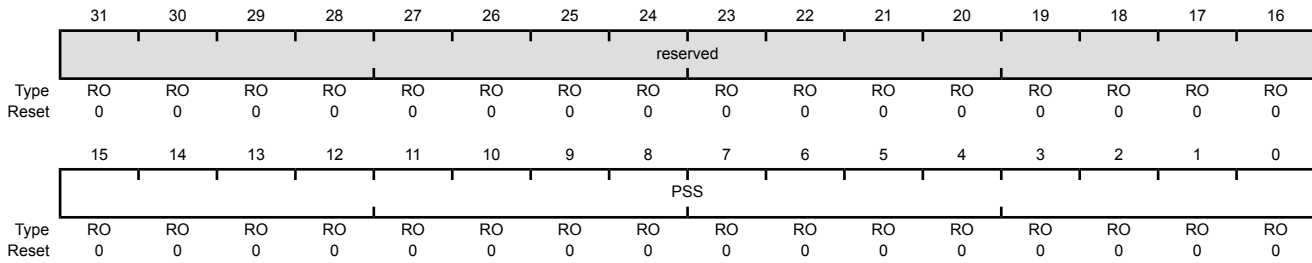

Bit/Field	Name	Type	Reset	Description
31:16	reserved	RO	0x0000	Software should not rely on the value of a reserved bit. To provide compatibility with future products, the value of a reserved bit should be preserved across a read-modify-write operation.
15:0	PSS	RO	0x0000	GPTM Timer A Prescaler Value A read returns the current value of the GPTM Timer A Prescaler .

Register 25: GPTM DMA Event (GPTMDMAEV), offset 0x06C

This register allows software to enable/disable GPTM DMA trigger events. Setting a bit enables the corresponding DMA trigger, while clearing a bit disables it.

GPTM DMA Event (GPTMDMAEV)

16/32-bit Timer 0 base: 0x4003.0000
 16/32-bit Timer 1 base: 0x4003.1000
 16/32-bit Timer 2 base: 0x4003.2000
 16/32-bit Timer 3 base: 0x4003.3000
 16/32-bit Timer 4 base: 0x4003.4000
 16/32-bit Timer 5 base: 0x4003.5000
 16/32-bit Timer 6 base: 0x400E.0000
 16/32-bit Timer 7 base: 0x400E.1000
 Offset 0x06C
 Type RW, reset 0x0000.0000

	31	30	29	28	27	26	25	24	23	22	21	20	19	18	17	16	
	reserved																
Type	RO	RO	RO	RO	RO	RO	RO	RO	RO	RO	RO	RO	RO	RO	RO	RO	
Reset	0	0	0	0	0	0	0	0	0	0	0	0	0	0	0	0	
	15	14	13	12	11	10	9	8	7	6	5	4	3	2	1	0	
	reserved				TBMDMAEN	CBEDMAEN	CBMDMAEN	TBTODMAEN	reserved				TAMDMAEN	RTCDMAEN	CAEDMAEN	CAMDMAEN	TATODMAEN
Type	RO	RO	RO	RO	RW	RW	RW	RW	RO	RO	RO	RW	RW	RW	RW	RW	
Reset	0	0	0	0	0	0	0	0	0	0	0	0	0	0	0	0	

Bit/Field	Name	Type	Reset	Description
31:12	reserved	RO	0	Software should not rely on the value of a reserved bit. To provide compatibility with future products, the value of a reserved bit should be preserved across a read-modify-write operation.
11	TBMDMAEN	RW	0	GPTM B Mode Match Event DMA Trigger Enable When this bit is enabled, a Timer B <code>dma_req</code> signal is sent to the μ DMA when a mode match has occurred. Value Description 0 Timer B Mode Match DMA trigger is disabled. 1 Timer B DMA Mode Match trigger is enabled.
10	CBEDMAEN	RW	0	GPTM B Capture Event DMA Trigger Enable When this bit is enabled, a Timer B <code>dma_req</code> signal is sent to the μ DMA when a capture event has occurred. Value Description 0 Timer B Capture Event DMA trigger is disabled. 1 Timer B Capture Event DMA trigger is enabled.
9	CBMDMAEN	RW	0	GPTM B Capture Match Event DMA Trigger Enable When this bit is enabled, a Timer B <code>dma_req</code> signal is sent to the μ DMA when a capture match event has occurred. Value Description 0 Timer B Capture Match DMA trigger is disabled. 1 Timer B Capture Match DMA trigger is enabled.

Bit/Field	Name	Type	Reset	Description
8	TBTODMAEN	RW	0	<p>GPTM B Time-Out Event DMA Trigger Enable</p> <p>When this bit is enabled, a Timer B <code>dma_req</code> signal is sent to the μDMA on a time-out event.</p> <p>Value Description</p> <p>0 Timer B Time-Out DMA trigger is disabled.</p> <p>1 Timer B Time-Out DMA trigger is enabled.</p>
7:5	reserved	RO	0	<p>Software should not rely on the value of a reserved bit. To provide compatibility with future products, the value of a reserved bit should be preserved across a read-modify-write operation.</p>
4	TAMDMAEN	RW	0	<p>GPTM A Mode Match Event DMA Trigger Enable</p> <p>When this bit is enabled, a Timer A <code>dma_req</code> signal is sent to the μDMA when a mode match has occurred.</p> <p>Value Description</p> <p>0 Timer A Mode Match DMA trigger is disabled.</p> <p>1 Timer A DMA Mode Match trigger is enabled.</p>
3	RTCDMAEN	RW	0	<p>GPTM A RTC Match Event DMA Trigger Enable</p> <p>When this bit is enabled, a Timer A <code>dma_req</code> signal is sent to the μDMA when a RTC match has occurred.</p> <p>Value Description</p> <p>0 Timer A RTC Match DMA trigger is disabled.</p> <p>1 Timer A RTC Match DMA trigger is enabled.</p>
2	CAEDMAEN	RW	0	<p>GPTM A Capture Event DMA Trigger Enable</p> <p>When this bit is enabled, a Timer A <code>dma_req</code> signal is sent to the μDMA when a capture event has occurred.</p> <p>Value Description</p> <p>0 Timer A Capture Event DMA trigger is disabled.</p> <p>1 Timer A Capture Event DMA trigger is enabled.</p>
1	CAMDMAEN	RW	0	<p>GPTM A Capture Match Event DMA Trigger Enable</p> <p>When this bit is enabled, a Timer A <code>dma_req</code> signal is sent to the μDMA when a capture match event has occurred.</p> <p>Value Description</p> <p>0 Timer A Capture Match DMA trigger is disabled.</p> <p>1 Timer A Capture Match DMA trigger is enabled.</p>

Bit/Field	Name	Type	Reset	Description
0	TATODMAEN	RW	0	GPTM A Time-Out Event DMA Trigger Enable When this bit is enabled, a Timer A <code>dma_req</code> signal is sent to the μ DMA on a time-out event. Value Description 0 Timer A Time-Out DMA trigger is disabled. 1 Timer A Time-Out DMA trigger is enabled.

Register 26: GPTM ADC Event (GPTMADCEV), offset 0x070

This register allows software to enable/disable GPTM ADC trigger events. Setting a bit enables the corresponding ADC trigger, while clearing a bit disables it.

GPTM ADC Event (GPTMADCEV)

16/32-bit Timer 0 base: 0x4003.0000
 16/32-bit Timer 1 base: 0x4003.1000
 16/32-bit Timer 2 base: 0x4003.2000
 16/32-bit Timer 3 base: 0x4003.3000
 16/32-bit Timer 4 base: 0x4003.4000
 16/32-bit Timer 5 base: 0x4003.5000
 16/32-bit Timer 6 base: 0x400E.0000
 16/32-bit Timer 7 base: 0x400E.1000
 Offset 0x070
 Type RW, reset 0x0000.0000

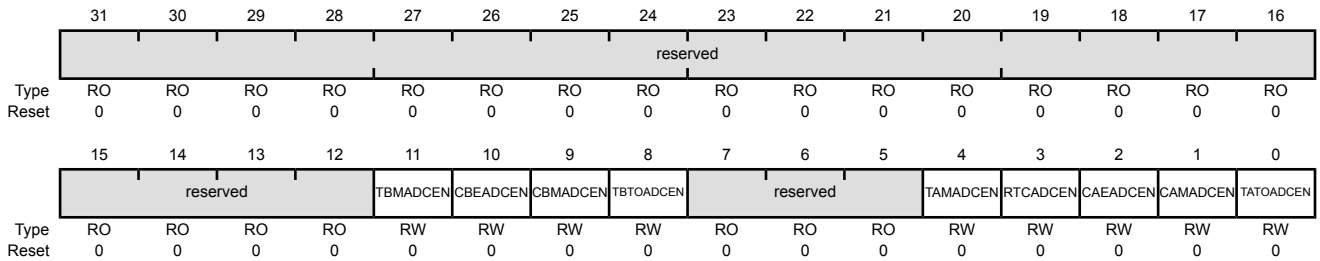

Bit/Field	Name	Type	Reset	Description
31:12	reserved	RO	0	Software should not rely on the value of a reserved bit. To provide compatibility with future products, the value of a reserved bit should be preserved across a read-modify-write operation.
11	TBMADCEN	RW	0	GPTM B Mode Match Event ADC Trigger Enable When this bit is enabled, a a trigger pulse is sent to the ADC when a mode match has occurred. Value Description 0 Timer B Mode Match ADC trigger is disabled. 1 Timer B Mode Match ADC trigger is enabled.
10	CBEADCEN	RW	0	GPTM B Capture Event ADC Trigger Enable When this bit is enabled, a trigger pulse is sent to the ADC when a capture event has occurred. Value Description 0 Timer B Capture Event ADC trigger is disabled. 1 Timer B Capture Event ADC trigger is enabled.
9	CBMADCEN	RW	0	GPTM B Capture Match Event ADC Trigger Enable When this bit is enabled, a trigger signal is sent to the ADC when a capture match event has occurred. Value Description 0 Timer B Capture Match ADC trigger is disabled. 1 Timer B Capture Match ADC trigger is enabled.

Bit/Field	Name	Type	Reset	Description
8	TBTOADCEN	RW	0	<p>GPTM B Time-Out Event ADC Trigger Enable</p> <p>When this bit is enabled, a trigger signal is sent to the ADC on a time-out event.</p> <p>Value Description</p> <p>0 Timer B Time-Out ADC trigger is disabled.</p> <p>1 Timer B Time-Out ADC trigger is enabled.</p>
7:5	reserved	RO	0	Software should not rely on the value of a reserved bit. To provide compatibility with future products, the value of a reserved bit should be preserved across a read-modify-write operation.
4	TAMADCEN	RW	0	<p>GPTM A Mode Match Event ADC Trigger Enable</p> <p>When this bit is enabled, a a trigger pulse is sent to the ADC when a mode match has occurred.</p> <p>Value Description</p> <p>0 Timer A Mode Match ADC trigger is disabled.</p> <p>1 Timer A Mode Match ADC trigger is enabled.</p>
3	RTCADCEN	RW	0	<p>GPTM RTC Match Event ADC Trigger Enable</p> <p>When this bit is enabled, a trigger signal is sent to the ADC when a RTC match has occurred.</p> <p>Value Description</p> <p>0 Timer A RTC Match ADC trigger is disabled.</p> <p>1 Timer A RTC Match ADC trigger is enabled.</p>
2	CAEADCEN	RW	0	<p>GPTM A Capture Event ADC Trigger Enable</p> <p>When this bit is enabled, a trigger pulse is sent to the ADC when a capture event has occurred.</p> <p>Value Description</p> <p>0 Timer A Capture Event ADC trigger is disabled.</p> <p>1 Timer A Capture Event ADC trigger is enabled.</p>
1	CAMADCEN	RW	0	<p>GPTM A Capture Match Event ADC Trigger Enable</p> <p>When this bit is enabled, a trigger signal is sent to the ADC when a capture match event has occurred.</p> <p>Value Description</p> <p>0 Timer A Capture Match ADC trigger is disabled.</p> <p>1 Timer A Capture Match ADC trigger is enabled.</p>

Bit/Field	Name	Type	Reset	Description
0	TATOADCEN	RW	0	GPTM A Time-Out Event ADC Trigger Enable When this bit is enabled, a trigger signal is sent to the ADC on a time-out event.
				Value Description
				0 Timer A Time-Out Event ADC trigger is disabled.
				1 Timer A Time-Out Event ADC trigger is enabled.

Register 27: GPTM Peripheral Properties (GPTMPP), offset 0xFC0

The **GPTMPP** register provides information regarding the properties of the General-Purpose Timer module.

GPTM Peripheral Properties (GPTMPP)

16/32-bit Timer 0 base: 0x4003.0000
 16/32-bit Timer 1 base: 0x4003.1000
 16/32-bit Timer 2 base: 0x4003.2000
 16/32-bit Timer 3 base: 0x4003.3000
 16/32-bit Timer 4 base: 0x4003.4000
 16/32-bit Timer 5 base: 0x4003.5000
 16/32-bit Timer 6 base: 0x400E.0000
 16/32-bit Timer 7 base: 0x400E.1000
 Offset 0xFC0
 Type RO, reset 0x0000.0070

	31	30	29	28	27	26	25	24	23	22	21	20	19	18	17	16
	reserved															
Type	RO	RO	RO	RO	RO	RO	RO	RO	RO	RO	RO	RO	RO	RO	RO	RO
Reset	0	0	0	0	0	0	0	0	0	0	0	0	0	0	0	0
	15	14	13	12	11	10	9	8	7	6	5	4	3	2	1	0
	reserved										ALTCLK	SYNCCNT	CHAIN	SIZE		
Type	RO	RO	RO	RO	RO	RO	RO	RO	RO	RO	RO	RO	RO	RO	RO	RO
Reset	0	0	0	0	0	0	0	0	0	1	1	1	0	0	0	0

Bit/Field	Name	Type	Reset	Description
31:7	reserved	RO	0	Software should not rely on the value of a reserved bit. To provide compatibility with future products, the value of a reserved bit should be preserved across a read-modify-write operation.
6	ALTCLK	RO	0x1	Alternate Clock Source Value Description 0 The alternate clock source (ALTCLK) is not available to the Timer module. 1 The alternate clock source (ALTCLK) is available to the Timer module.
5	SYNCCNT	RO	0x1	Synchronize Start Value Description 0 Timer is not capable of synchronizing the counter value with other GPTimers. 1 Timer is capable of synchronizing the counter value with other Timers.
4	CHAIN	RO	0x1	Chain with Other Timers Value Description 0 Timer is not capable of chaining with the previously numbered Timer. 1 Timer is capable of chaining with the previously numbered Timer.

Note that although this bit is set for Timer 0A, this timer cannot chain because there is not a previously numbered Timer.

Bit/Field	Name	Type	Reset	Description
3:0	SIZE	RO	0x0	Count Size
				Value Description
				0 Timer A and Timer B counters are 16 bits each with an 8-bit prescale counter.
				1 Timer A and Timer B counters are 32 bits each with a 16-bit prescale counter.

Register 28: GPTM Clock Configuration (GPTMCC), offset 0xFC8

The **GPTMCC** register controls the clock source for the General-Purpose Timer module.

Note: When the **ALTCLK** bit is set in the **GPTMCC** register to enable using the alternate clock source, the synchronization imposes restrictions on the starting count value (down-count), terminal value (up-count) and the match value. This restriction applies to all modes of operation. Each event must be spaced by 4 Timer (ALTCLK) clock periods + 2 system clock periods. If some events do not meet this requirement, then it is possible that the timer block may need to be reset for correct functionality to be restored.

Example: $ALTCLK = T_{PIOSC} = 62.5ns$ (16Mhz Trimmed)

$T_{hclk} = 1\mu s$ (1Mhz)

$4 * 62.5ns + 2 * 1\mu s = 2.25\mu s$ $2.25\mu s / 62.5ns = 36$ or 0x23

The minimum values for the periodic or one-shot with a match interrupt enabled are:
GPTMTAMATCHR = 0x23 **GPTMTAILR = 0x46**

GPTM Clock Configuration (GPTMCC)

16/32-bit Timer 0 base: 0x4003.0000
 16/32-bit Timer 1 base: 0x4003.1000
 16/32-bit Timer 2 base: 0x4003.2000
 16/32-bit Timer 3 base: 0x4003.3000
 16/32-bit Timer 4 base: 0x4003.4000
 16/32-bit Timer 5 base: 0x4003.5000
 16/32-bit Timer 6 base: 0x400E.0000
 16/32-bit Timer 7 base: 0x400E.1000
 Offset 0xFC8
 Type RW, reset 0x0000.0000

	31	30	29	28	27	26	25	24	23	22	21	20	19	18	17	16
	reserved															
Type	RO	RO	RO	RO	RO	RO	RO	RO	RO	RO	RO	RO	RO	RO	RO	RO
Reset	0	0	0	0	0	0	0	0	0	0	0	0	0	0	0	0
	15	14	13	12	11	10	9	8	7	6	5	4	3	2	1	0
	reserved															ALTCLK
Type	RO	RO	RO	RO	RO	RO	RO	RO	RO	RO	RO	RO	RO	RO	RO	RW
Reset	0	0	0	0	0	0	0	0	0	0	0	0	0	0	0	0

Bit/Field	Name	Type	Reset	Description
31:1	reserved	RO	0x0000.0000	Software should not rely on the value of a reserved bit. To provide compatibility with future products, the value of a reserved bit should be preserved across a read-modify-write operation.
0	ALTCLK	RW	0x0	Alternate Clock Source
				Value Description
			0	System clock (based on clock source and divisor factor programmed in RSCLKCFG register in the System Control Module)
			1	Alternate clock source as defined by ALTCLKCFG register in System Control Module.

17 Watchdog Timers

A watchdog timer can generate a non-maskable interrupt (NMI), a regular interrupt or a reset when a time-out value is reached. The watchdog timer is used to regain control when a system has failed due to a software error or due to the failure of an external device to respond in the expected way. The TM4C129ENC PDT microcontroller has two Watchdog Timer Modules, one module is clocked by the system clock (Watchdog Timer 0) and the other (Watchdog Timer 1) is clocked by the clock source programmed in the `ALTCLK` field of the **Alternate Clock Configuration (ALTCLKCFG)** register, System Control offset 0x138. The two modules are identical except that WDT1 is in a different clock domain, and therefore requires synchronizers. As a result, WDT1 has a bit defined in the **Watchdog Timer Control (WDTCTL)** register to indicate when a write to a WDT1 register is complete. Software can use this bit to ensure that the previous access has completed before starting the next access.

The TM4C129ENC PDT controller has two Watchdog Timer modules with the following features:

- 32-bit down counter with a programmable load register
- Separate watchdog clock with an enable
- Programmable interrupt generation logic with interrupt masking and optional NMI function
- Lock register protection from runaway software
- Reset generation logic with an enable/disable
- User-enabled stalling when the microcontroller asserts the CPU Halt flag during debug

The Watchdog Timer can be configured to generate an interrupt to the controller on its first time-out, and to generate a reset signal on its second time-out. Once the Watchdog Timer has been configured, the lock register can be written to prevent the timer configuration from being inadvertently altered.

17.1 Block Diagram

Figure 17-1. WDT Module Block Diagram

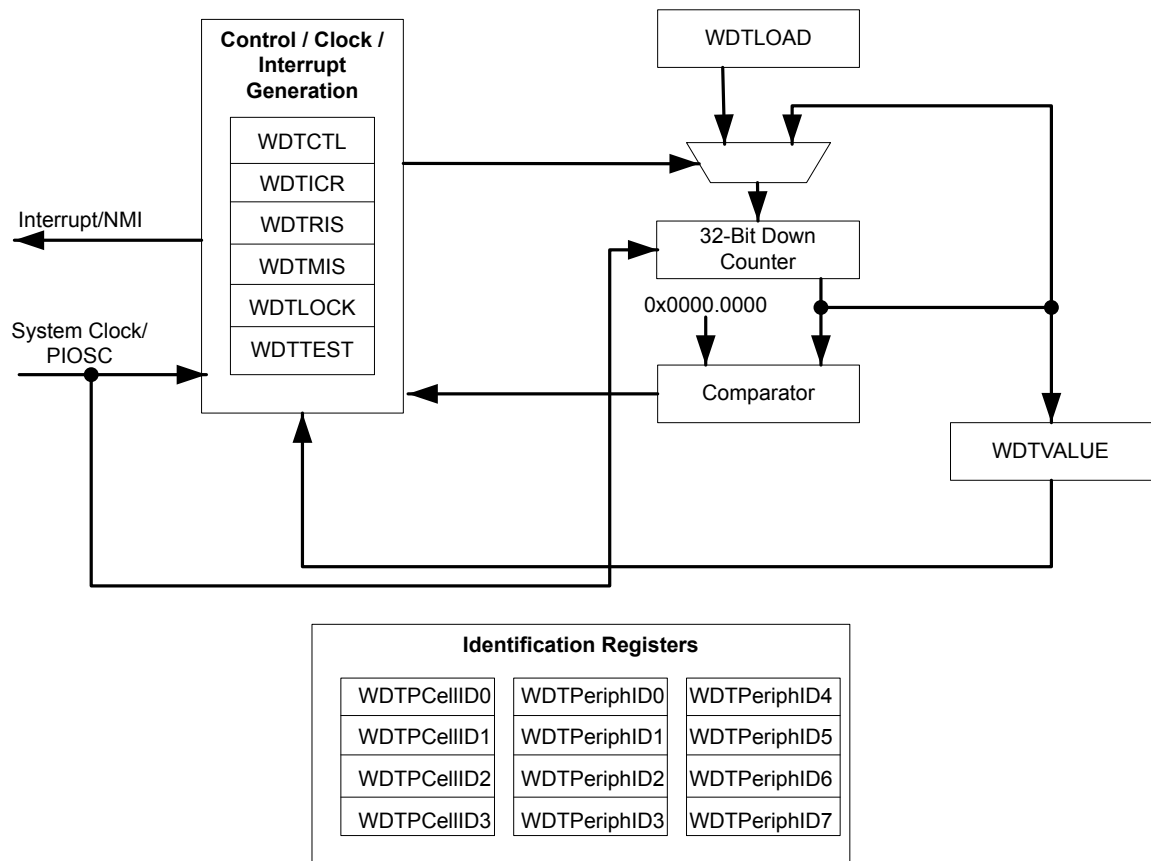

17.2 Functional Description

The Watchdog Timer module generates the first time-out signal when the 32-bit counter reaches the zero state after being enabled; enabling the counter also enables the watchdog timer interrupt. The watchdog interrupt can be programmed to be a non-maskable interrupt (NMI) using the `INTTYPE` bit in the **WDTCTL** register. After the first time-out event, the 32-bit counter is re-loaded with the value of the **Watchdog Timer Load (WDTLOAD)** register, and the timer resumes counting down from that value. Once the Watchdog Timer has been configured, the **Watchdog Timer Lock (WDTLOCK)** register is written, which prevents the timer configuration from being inadvertently altered by software.

If the timer counts down to its zero state again before the first time-out interrupt is cleared, and the reset signal has been enabled by setting the `RESEN` bit in the **WDTCTL** register, the Watchdog timer asserts its reset signal to the system. If the interrupt is cleared before the 32-bit counter reaches its second time-out, the 32-bit counter is loaded with the value in the **WDTLOAD** register, and counting resumes from that value.

If **WDTLOAD** is written with a new value while the Watchdog Timer counter is counting, then the counter is loaded with the new value and continues counting.

Writing to **WDTLOAD** does not clear an active interrupt. An interrupt must be specifically cleared by writing to the **Watchdog Interrupt Clear (WDTICR)** register.

The Watchdog module interrupt and reset generation can be enabled or disabled as required. When the interrupt is re-enabled, the 32-bit counter is preloaded with the load register value and not its last state.

The watchdog timer is disabled by default out of reset. To achieve maximum watchdog protection of the device, the watchdog timer can be enabled at the start of the reset vector.

17.2.1 Register Access Timing

Because the Watchdog Timer 1 module has an independent clocking domain, its registers must be written with a timing gap between accesses. Software must guarantee that this delay is inserted between back-to-back writes to WDT1 registers or between a write followed by a read to the registers. The timing for back-to-back reads from the WDT1 module has no restrictions. The **WRC** bit in the **Watchdog Control (WDTCTL)** register for WDT1 indicates that the required timing gap has elapsed. This bit is cleared on a write operation and set once the write completes, indicating to software that another write or read may be started safely. Software should poll **WDTCTL** for **WRC=1** prior to accessing another register. Note that WDT0 does not have this restriction as it runs off the system clock.

17.3 Initialization and Configuration

To use the WDT, its peripheral clock must be enabled by setting the **Rn** bit in the **Watchdog Timer Run Mode Clock Gating Control (RCGCWD)** register, see page 386.

The Watchdog Timer is configured using the following sequence:

1. Load the **WDTLOAD** register with the desired timer load value.
2. If WDT1, wait for the **WRC** bit in the **WDTCTL** register to be set.
3. Set the **INTEN** bit (if interrupts are required) or the **RESEN** bit (if a reset is required after two timeouts) in the **WDTCTL** register. The Watchdog Timer starts when either of them is enabled.

If software requires that all of the watchdog registers are locked, the Watchdog Timer module can be fully locked by writing any value to the **WDTLOCK** register. To unlock the Watchdog Timer, write a value of 0x1ACC.E551.

To service the watchdog, periodically reload the count value into the **WDTLOAD** register to restart the count. The interrupt can be enabled using the **INTEN** bit in the **WDTCTL** register to allow the processor to attempt corrective action if the watchdog is not serviced often enough. The **RESEN** bit in **WDTCTL** can be set so that the system resets if the failure is not recoverable using the ISR.

Note: The application should be sure not to modify the **ALTCLK** encoding in the **ALTCLKCFG** register while the WDT1 is enabled and running.

17.4 Register Map

Table 17-1 on page 1155 lists the Watchdog registers. The offset listed is a hexadecimal increment to the register's address, relative to the Watchdog Timer base address:

- WDT0: 0x4000.0000
- WDT1: 0x4000.1000

Note that the Watchdog Timer module clock must be enabled before the registers can be programmed (see page 386).

Table 17-1. Watchdog Timers Register Map

Offset	Name	Type	Reset	Description	See page
0x000	WDTLOAD	RW	0xFFFF.FFFF	Watchdog Load	1156
0x004	WDTVALUE	RO	0xFFFF.FFFF	Watchdog Value	1157
0x008	WDTCTL	RW	0x0000.0000 (WDT0) 0x8000.0000 (WDT1)	Watchdog Control	1158
0x00C	WDTICR	WO	-	Watchdog Interrupt Clear	1160
0x010	WDTRIS	RO	0x0000.0000	Watchdog Raw Interrupt Status	1161
0x014	WDTMIS	RO	0x0000.0000	Watchdog Masked Interrupt Status	1162
0x418	WDTTEST	RW	0x0000.0000	Watchdog Test	1163
0xC00	WDTLOCK	RW	0x0000.0000	Watchdog Lock	1164
0xFD0	WDTPeriphID4	RO	0x0000.0000	Watchdog Peripheral Identification 4	1165
0xFD4	WDTPeriphID5	RO	0x0000.0000	Watchdog Peripheral Identification 5	1166
0xFD8	WDTPeriphID6	RO	0x0000.0000	Watchdog Peripheral Identification 6	1167
0xFDC	WDTPeriphID7	RO	0x0000.0000	Watchdog Peripheral Identification 7	1168
0xFE0	WDTPeriphID0	RO	0x0000.0005	Watchdog Peripheral Identification 0	1169
0xFE4	WDTPeriphID1	RO	0x0000.0018	Watchdog Peripheral Identification 1	1170
0xFE8	WDTPeriphID2	RO	0x0000.0018	Watchdog Peripheral Identification 2	1171
0xFEC	WDTPeriphID3	RO	0x0000.0001	Watchdog Peripheral Identification 3	1172
0xFF0	WDTPrimeCellID0	RO	0x0000.000D	Watchdog PrimeCell Identification 0	1173
0xFF4	WDTPrimeCellID1	RO	0x0000.00F0	Watchdog PrimeCell Identification 1	1174
0xFF8	WDTPrimeCellID2	RO	0x0000.0006	Watchdog PrimeCell Identification 2	1175
0xFFC	WDTPrimeCellID3	RO	0x0000.00B1	Watchdog PrimeCell Identification 3	1176

17.5 Register Descriptions

The remainder of this section lists and describes the WDT registers, in numerical order by address offset.

Register 1: Watchdog Load (WDTLOAD), offset 0x000

This register is the 32-bit interval value used by the 32-bit counter. When this register is written, the value is immediately loaded and the counter restarts counting down from the new value. If the **WDTLOAD** register is loaded with 0x0000.0000, an interrupt is immediately generated.

Watchdog Load (WDTLOAD)

WDT0 base: 0x4000.0000
 WDT1 base: 0x4000.1000
 Offset 0x000
 Type RW, reset 0xFFFF.FFFF

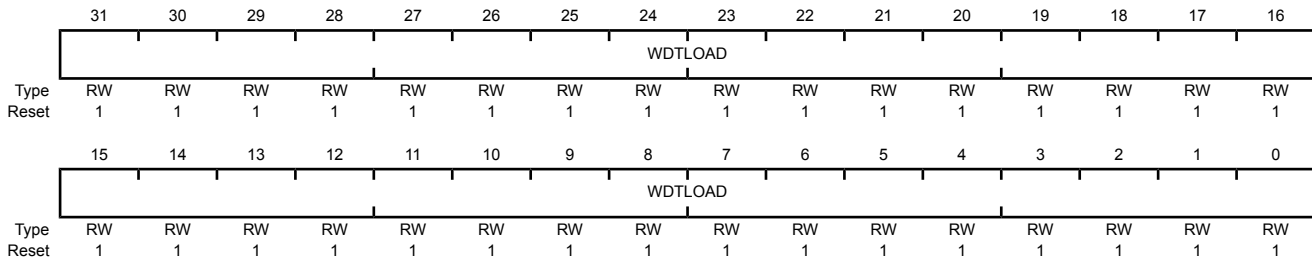

Bit/Field	Name	Type	Reset	Description
31:0	WDTLOAD	RW	0xFFFF.FFFF	Watchdog Load Value

Register 2: Watchdog Value (WDTVALUE), offset 0x004

This register contains the current count value of the timer.

Watchdog Value (WDTVALUE)

WDT0 base: 0x4000.0000

WDT1 base: 0x4000.1000

Offset 0x004

Type RO, reset 0xFFFF.FFFF

	31	30	29	28	27	26	25	24	23	22	21	20	19	18	17	16
	WDTVALUE															
Type	RO	RO	RO	RO	RO	RO	RO	RO	RO	RO	RO	RO	RO	RO	RO	RO
Reset	1	1	1	1	1	1	1	1	1	1	1	1	1	1	1	1
	15	14	13	12	11	10	9	8	7	6	5	4	3	2	1	0
	WDTVALUE															
Type	RO	RO	RO	RO	RO	RO	RO	RO	RO	RO	RO	RO	RO	RO	RO	RO
Reset	1	1	1	1	1	1	1	1	1	1	1	1	1	1	1	1

Bit/Field	Name	Type	Reset	Description
31:0	WDTVALUE	RO	0xFFFF.FFFF	Watchdog Value Current value of the 32-bit down counter.

Register 3: Watchdog Control (WDTCTL), offset 0x008

This register is the watchdog control register. The watchdog timer can be configured to generate a reset signal (on second time-out) or an interrupt on time-out.

When the watchdog interrupt has been enabled by setting the `INTEN` bit, all subsequent writes to the `INTEN` bit are ignored. The only mechanisms that can re-enable writes to this bit are a hardware reset or a software reset initiated by setting the appropriate bit in the **Watchdog Timer Software Reset (SRWD)** register.

Important: Because the Watchdog Timer 1 module has an independent clocking domain, its registers must be written with a timing gap between accesses. Software must guarantee that this delay is inserted between back-to-back writes to WDT1 registers or between a write followed by a read to the registers. The timing for back-to-back reads from the WDT1 module has no restrictions. The `WRC` bit in the **Watchdog Control (WDTCTL)** register for WDT1 indicates that the required timing gap has elapsed. This bit is cleared on a write operation and set once the write completes, indicating to software that another write or read may be started safely. Software should poll **WDTCTL** for `WRC=1` prior to accessing another register. Note that WDT0 does not have this restriction as it runs off the system clock and therefore does not have a `WRC` bit.

Watchdog Control (WDTCTL)

WDT0 base: 0x4000.0000

WDT1 base: 0x4000.1000

Offset 0x008

Type RW, reset 0x0000.0000 (WDT0) and 0x8000.0000 (WDT1)

	31	30	29	28	27	26	25	24	23	22	21	20	19	18	17	16	
	WRC	reserved															
Type	RO	RO	RO	RO	RO	RO	RO	RO	RO	RO	RO	RO	RO	RO	RO	RO	
Reset	1	0	0	0	0	0	0	0	0	0	0	0	0	0	0	0	
	15	14	13	12	11	10	9	8	7	6	5	4	3	2	1	0	
	reserved													INTTYPE	RESEN	INTEN	
Type	RO	RO	RO	RO	RO	RO	RO	RO	RO	RO	RO	RO	RO	RO	RW	RW	RW
Reset	0	0	0	0	0	0	0	0	0	0	0	0	0	0	0	0	0

Bit/Field	Name	Type	Reset	Description						
31	WRC	RO	1	Write Complete The <code>WRC</code> values are defined as follows: <table border="1"> <thead> <tr> <th>Value</th> <th>Description</th> </tr> </thead> <tbody> <tr> <td>0</td> <td>A write access to one of the WDT1 registers is in progress.</td> </tr> <tr> <td>1</td> <td>A write access is not in progress, and WDT1 registers can be read or written.</td> </tr> </tbody> </table>	Value	Description	0	A write access to one of the WDT1 registers is in progress.	1	A write access is not in progress, and WDT1 registers can be read or written.
Value	Description									
0	A write access to one of the WDT1 registers is in progress.									
1	A write access is not in progress, and WDT1 registers can be read or written.									
30:3	reserved	RO	0x000.000	Software should not rely on the value of a reserved bit. To provide compatibility with future products, the value of a reserved bit should be preserved across a read-modify-write operation.						

Bit/Field	Name	Type	Reset	Description						
2	INTTYPE	RW	0	Watchdog Interrupt Type The <code>INTTYPE</code> values are defined as follows: <table border="1"> <thead> <tr> <th>Value</th> <th>Description</th> </tr> </thead> <tbody> <tr> <td>0</td> <td>Watchdog interrupt is a standard interrupt.</td> </tr> <tr> <td>1</td> <td>Watchdog interrupt is a non-maskable interrupt.</td> </tr> </tbody> </table>	Value	Description	0	Watchdog interrupt is a standard interrupt.	1	Watchdog interrupt is a non-maskable interrupt.
Value	Description									
0	Watchdog interrupt is a standard interrupt.									
1	Watchdog interrupt is a non-maskable interrupt.									
1	RESEN	RW	0	Watchdog Reset Enable The <code>RESEN</code> values are defined as follows: <table border="1"> <thead> <tr> <th>Value</th> <th>Description</th> </tr> </thead> <tbody> <tr> <td>0</td> <td>Disabled.</td> </tr> <tr> <td>1</td> <td>Enable the Watchdog module reset output. Setting this bit enables the Watchdog Timer.</td> </tr> </tbody> </table>	Value	Description	0	Disabled.	1	Enable the Watchdog module reset output. Setting this bit enables the Watchdog Timer.
Value	Description									
0	Disabled.									
1	Enable the Watchdog module reset output. Setting this bit enables the Watchdog Timer.									
0	INTEN	RW	0	Watchdog Interrupt Enable The <code>INTEN</code> values are defined as follows: <table border="1"> <thead> <tr> <th>Value</th> <th>Description</th> </tr> </thead> <tbody> <tr> <td>0</td> <td>Interrupt event disabled. Once this bit is set, it can only be cleared by a hardware reset or a software reset initiated by setting the appropriate bit in the Watchdog Timer Software Reset (SRWD) register.</td> </tr> <tr> <td>1</td> <td>Interrupt event enabled. Once enabled, all writes are ignored. Setting this bit enables the Watchdog Timer.</td> </tr> </tbody> </table>	Value	Description	0	Interrupt event disabled. Once this bit is set, it can only be cleared by a hardware reset or a software reset initiated by setting the appropriate bit in the Watchdog Timer Software Reset (SRWD) register.	1	Interrupt event enabled. Once enabled, all writes are ignored. Setting this bit enables the Watchdog Timer.
Value	Description									
0	Interrupt event disabled. Once this bit is set, it can only be cleared by a hardware reset or a software reset initiated by setting the appropriate bit in the Watchdog Timer Software Reset (SRWD) register.									
1	Interrupt event enabled. Once enabled, all writes are ignored. Setting this bit enables the Watchdog Timer.									

Register 4: Watchdog Interrupt Clear (WDTICR), offset 0x00C

This register is the interrupt clear register. A write of any value to this register clears the Watchdog interrupt and reloads the 32-bit counter from the **WDTLOAD** register. Write to this register when a watchdog time-out interrupt has occurred to properly service the Watchdog. Value for a read or reset is indeterminate.

Note: Locking the watchdog registers by using the **WDTLOCK** register does not affect the **WDTICR** register and allows interrupts to always be serviced. Thus, a write at any time of the **WDTICR** register clears the **WDTMIS** register and reloads the 32-bit counter from the **WDTLOAD** register. The **WDTICR** register should only be written when interrupts have triggered and need to be serviced.

Watchdog Interrupt Clear (WDTICR)

WDT0 base: 0x4000.0000

WDT1 base: 0x4000.1000

Offset 0x00C

Type WO, reset -



Bit/Field	Name	Type	Reset	Description
31:0	WDTINTCLR	WO	-	<p>Watchdog Interrupt Clear</p> <p>A write of any value to this register clears the Watchdog interrupt and reloads the 32-bit counter from the WDTLOAD register. Write to this register when a watchdog time-out interrupt has occurred to properly service the Watchdog. Value for a read or reset is indeterminate.</p>

Register 5: Watchdog Raw Interrupt Status (WDTRIS), offset 0x010

This register is the raw interrupt status register. Watchdog interrupt events can be monitored via this register if the controller interrupt is masked.

Watchdog Raw Interrupt Status (WDTRIS)

WDT0 base: 0x4000.0000
 WDT1 base: 0x4000.1000
 Offset 0x010
 Type RO, reset 0x0000.0000

	31	30	29	28	27	26	25	24	23	22	21	20	19	18	17	16
	reserved															
Type	RO	RO	RO	RO	RO	RO	RO	RO	RO	RO	RO	RO	RO	RO	RO	RO
Reset	0	0	0	0	0	0	0	0	0	0	0	0	0	0	0	0
	15	14	13	12	11	10	9	8	7	6	5	4	3	2	1	0
	reserved															WDTRIS
Type	RO	RO	RO	RO	RO	RO	RO	RO	RO	RO	RO	RO	RO	RO	RO	RO
Reset	0	0	0	0	0	0	0	0	0	0	0	0	0	0	0	0

Bit/Field	Name	Type	Reset	Description
31:1	reserved	RO	0x0000.000	Software should not rely on the value of a reserved bit. To provide compatibility with future products, the value of a reserved bit should be preserved across a read-modify-write operation.
0	WDTRIS	RO	0	Watchdog Raw Interrupt Status

Value Description

0	The watchdog has not timed out.
1	A watchdog time-out event has occurred.

Register 6: Watchdog Masked Interrupt Status (WDTMIS), offset 0x014

This register is the masked interrupt status register. The value of this register is the logical AND of the raw interrupt bit and the Watchdog interrupt enable bit.

Watchdog Masked Interrupt Status (WDTMIS)

WDT0 base: 0x4000.0000
 WDT1 base: 0x4000.1000
 Offset 0x014
 Type RO, reset 0x0000.0000

	31	30	29	28	27	26	25	24	23	22	21	20	19	18	17	16
	reserved															
Type	RO	RO	RO	RO	RO	RO	RO	RO	RO	RO	RO	RO	RO	RO	RO	RO
Reset	0	0	0	0	0	0	0	0	0	0	0	0	0	0	0	0
	15	14	13	12	11	10	9	8	7	6	5	4	3	2	1	0
	reserved															WDTMIS
Type	RO	RO	RO	RO	RO	RO	RO	RO	RO	RO	RO	RO	RO	RO	RO	RO
Reset	0	0	0	0	0	0	0	0	0	0	0	0	0	0	0	0

Bit/Field	Name	Type	Reset	Description
31:1	reserved	RO	0x0000.000	Software should not rely on the value of a reserved bit. To provide compatibility with future products, the value of a reserved bit should be preserved across a read-modify-write operation.
0	WDTMIS	RO	0	Watchdog Masked Interrupt Status
				Value Description
			0	The watchdog has not timed out or the watchdog timer interrupt is masked.
			1	A watchdog time-out event has been signalled to the interrupt controller.

Register 7: Watchdog Test (WDTTEST), offset 0x418

This register provides user-enabled stalling when the microcontroller asserts the CPU halt flag during debug.

Watchdog Test (WDTTEST)

WDT0 base: 0x4000.0000

WDT1 base: 0x4000.1000

Offset 0x418

Type RW, reset 0x0000.0000

	31	30	29	28	27	26	25	24	23	22	21	20	19	18	17	16
	reserved															
Type	RO	RO	RO	RO	RO	RO	RO	RO	RO	RO	RO	RO	RO	RO	RO	RO
Reset	0	0	0	0	0	0	0	0	0	0	0	0	0	0	0	0
	15	14	13	12	11	10	9	8	7	6	5	4	3	2	1	0
	reserved							STALL	reserved							
Type	RO	RO	RO	RO	RO	RO	RO	RW	RO	RO	RO	RO	RO	RO	RO	RO
Reset	0	0	0	0	0	0	0	0	0	0	0	0	0	0	0	0

Bit/Field	Name	Type	Reset	Description
31:9	reserved	RO	0x0000.00	Software should not rely on the value of a reserved bit. To provide compatibility with future products, the value of a reserved bit should be preserved across a read-modify-write operation.
8	STALL	RW	0	Watchdog Stall Enable Value Description 0 The watchdog timer continues counting if the microcontroller is stopped with a debugger. 1 If the microcontroller is stopped with a debugger, the watchdog timer stops counting. Once the microcontroller is restarted, the watchdog timer resumes counting.
7:0	reserved	RO	0x00	Software should not rely on the value of a reserved bit. To provide compatibility with future products, the value of a reserved bit should be preserved across a read-modify-write operation.

Register 8: Watchdog Lock (WDTLOCK), offset 0xC00

Writing 0x1ACC.E551 to the **WDTLOCK** register enables write access to all other registers. Writing any other value to the **WDTLOCK** register re-enables the locked state for register writes to all the other registers, except for the **Watchdog Test (WDTTEST)** register. Reading the **WDTLOCK** register returns the lock status rather than the 32-bit value written. Therefore, when write accesses are disabled, reading the **WDTLOCK** register returns 0x0000.0001 (when locked; otherwise, the returned value is 0x0000.0000 (unlocked)).

Watchdog Lock (WDTLOCK)

WDT0 base: 0x4000.0000
 WDT1 base: 0x4000.1000
 Offset 0xC00
 Type RW, reset 0x0000.0000

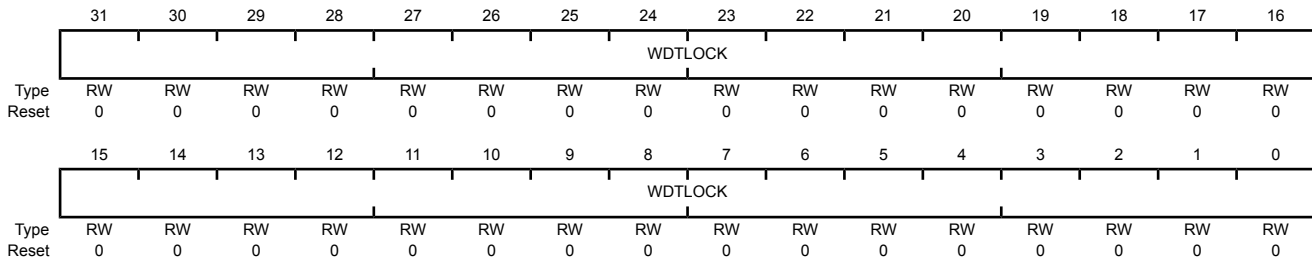

Bit/Field	Name	Type	Reset	Description
-----------	------	------	-------	-------------

31:0	WDTLOCK	RW	0x0000.0000	Watchdog Lock
------	---------	----	-------------	---------------

A write of the value 0x1ACC.E551 unlocks the watchdog registers for write access. A write of any other value reapplies the lock, preventing any register updates, except for the **WDTTEST** register. Avoid writes to the **WDTTEST** register when the watchdog registers are locked.

A read of this register returns the following values:

Value	Description
0x0000.0001	Locked
0x0000.0000	Unlocked

Register 9: Watchdog Peripheral Identification 4 (WDTPeriphID4), offset 0xFD0

The **WDTPeriphIDn** registers are hard-coded and the fields within the register determine the reset value.

Watchdog Peripheral Identification 4 (WDTPeriphID4)

WDT0 base: 0x4000.0000

WDT1 base: 0x4000.1000

Offset 0xFD0

Type RO, reset 0x0000.0000

	31	30	29	28	27	26	25	24	23	22	21	20	19	18	17	16
	reserved															
Type	RO	RO	RO	RO	RO	RO	RO	RO	RO	RO	RO	RO	RO	RO	RO	RO
Reset	0	0	0	0	0	0	0	0	0	0	0	0	0	0	0	0
	15	14	13	12	11	10	9	8	7	6	5	4	3	2	1	0
	reserved								PID4							
Type	RO	RO	RO	RO	RO	RO	RO	RO	RO	RO	RO	RO	RO	RO	RO	RO
Reset	0	0	0	0	0	0	0	0	0	0	0	0	0	0	0	0

Bit/Field	Name	Type	Reset	Description
31:8	reserved	RO	0x0000.00	Software should not rely on the value of a reserved bit. To provide compatibility with future products, the value of a reserved bit should be preserved across a read-modify-write operation.
7:0	PID4	RO	0x00	WDT Peripheral ID Register [7:0]

Register 10: Watchdog Peripheral Identification 5 (WDTPeriphID5), offset 0xFD4

The **WDTPeriphIDn** registers are hard-coded and the fields within the register determine the reset value.

Watchdog Peripheral Identification 5 (WDTPeriphID5)

WDT0 base: 0x4000.0000
 WDT1 base: 0x4000.1000
 Offset 0xFD4
 Type RO, reset 0x0000.0000

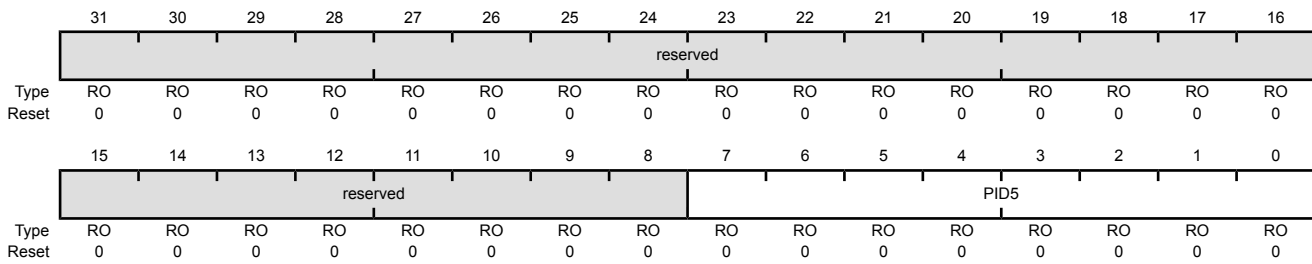

Bit/Field	Name	Type	Reset	Description
31:8	reserved	RO	0x0000.00	Software should not rely on the value of a reserved bit. To provide compatibility with future products, the value of a reserved bit should be preserved across a read-modify-write operation.
7:0	PID5	RO	0x00	WDT Peripheral ID Register [15:8]

Register 11: Watchdog Peripheral Identification 6 (WDTPeriphID6), offset 0xFD8

The **WDTPeriphIDn** registers are hard-coded and the fields within the register determine the reset value.

Watchdog Peripheral Identification 6 (WDTPeriphID6)

WDT0 base: 0x4000.0000

WDT1 base: 0x4000.1000

Offset 0xFD8

Type RO, reset 0x0000.0000

	31	30	29	28	27	26	25	24	23	22	21	20	19	18	17	16
	reserved															
Type	RO	RO	RO	RO	RO	RO	RO	RO	RO	RO	RO	RO	RO	RO	RO	RO
Reset	0	0	0	0	0	0	0	0	0	0	0	0	0	0	0	0
	15	14	13	12	11	10	9	8	7	6	5	4	3	2	1	0
	reserved								PID6							
Type	RO	RO	RO	RO	RO	RO	RO	RO	RO	RO	RO	RO	RO	RO	RO	RO
Reset	0	0	0	0	0	0	0	0	0	0	0	0	0	0	0	0

Bit/Field	Name	Type	Reset	Description
31:8	reserved	RO	0x0000.00	Software should not rely on the value of a reserved bit. To provide compatibility with future products, the value of a reserved bit should be preserved across a read-modify-write operation.
7:0	PID6	RO	0x00	WDT Peripheral ID Register [23:16]

Register 12: Watchdog Peripheral Identification 7 (WDTPeriphID7), offset 0xFDC

The **WDTPeriphIDn** registers are hard-coded and the fields within the register determine the reset value.

Watchdog Peripheral Identification 7 (WDTPeriphID7)

WDT0 base: 0x4000.0000
 WDT1 base: 0x4000.1000
 Offset 0xFDC
 Type RO, reset 0x0000.0000

	31	30	29	28	27	26	25	24	23	22	21	20	19	18	17	16
	reserved															
Type	RO	RO	RO	RO	RO	RO	RO	RO	RO	RO	RO	RO	RO	RO	RO	RO
Reset	0	0	0	0	0	0	0	0	0	0	0	0	0	0	0	0
	15	14	13	12	11	10	9	8	7	6	5	4	3	2	1	0
	reserved								PID7							
Type	RO	RO	RO	RO	RO	RO	RO	RO	RO	RO	RO	RO	RO	RO	RO	RO
Reset	0	0	0	0	0	0	0	0	0	0	0	0	0	0	0	0

Bit/Field	Name	Type	Reset	Description
31:8	reserved	RO	0x0000.00	Software should not rely on the value of a reserved bit. To provide compatibility with future products, the value of a reserved bit should be preserved across a read-modify-write operation.
7:0	PID7	RO	0x00	WDT Peripheral ID Register [31:24]

Register 13: Watchdog Peripheral Identification 0 (WDTPeriphID0), offset 0xFE0

The **WDTPeriphIDn** registers are hard-coded and the fields within the register determine the reset value.

Watchdog Peripheral Identification 0 (WDTPeriphID0)

WDT0 base: 0x4000.0000

WDT1 base: 0x4000.1000

Offset 0xFE0

Type RO, reset 0x0000.0005

	31	30	29	28	27	26	25	24	23	22	21	20	19	18	17	16
	reserved															
Type	RO	RO	RO	RO	RO	RO	RO	RO	RO	RO	RO	RO	RO	RO	RO	RO
Reset	0	0	0	0	0	0	0	0	0	0	0	0	0	0	0	0
	15	14	13	12	11	10	9	8	7	6	5	4	3	2	1	0
	reserved								PID0							
Type	RO	RO	RO	RO	RO	RO	RO	RO	RO	RO	RO	RO	RO	RO	RO	RO
Reset	0	0	0	0	0	0	0	0	0	0	0	0	0	1	0	1

Bit/Field	Name	Type	Reset	Description
31:8	reserved	RO	0x0000.00	Software should not rely on the value of a reserved bit. To provide compatibility with future products, the value of a reserved bit should be preserved across a read-modify-write operation.
7:0	PID0	RO	0x05	Watchdog Peripheral ID Register [7:0]

Register 14: Watchdog Peripheral Identification 1 (WDTPeriphID1), offset 0xFE4

The **WDTPeriphIDn** registers are hard-coded and the fields within the register determine the reset value.

Watchdog Peripheral Identification 1 (WDTPeriphID1)

WDT0 base: 0x4000.0000
 WDT1 base: 0x4000.1000
 Offset 0xFE4
 Type RO, reset 0x0000.0018

	31	30	29	28	27	26	25	24	23	22	21	20	19	18	17	16
	reserved															
Type	RO	RO	RO	RO	RO	RO	RO	RO	RO	RO	RO	RO	RO	RO	RO	RO
Reset	0	0	0	0	0	0	0	0	0	0	0	0	0	0	0	0
	15	14	13	12	11	10	9	8	7	6	5	4	3	2	1	0
	reserved								PID1							
Type	RO	RO	RO	RO	RO	RO	RO	RO	RO	RO	RO	RO	RO	RO	RO	RO
Reset	0	0	0	0	0	0	0	0	0	0	0	1	1	0	0	0

Bit/Field	Name	Type	Reset	Description
31:8	reserved	RO	0x0000.00	Software should not rely on the value of a reserved bit. To provide compatibility with future products, the value of a reserved bit should be preserved across a read-modify-write operation.
7:0	PID1	RO	0x18	Watchdog Peripheral ID Register [15:8]

Register 15: Watchdog Peripheral Identification 2 (WDTPeriphID2), offset 0xFE8

The **WDTPeriphIDn** registers are hard-coded and the fields within the register determine the reset value.

Watchdog Peripheral Identification 2 (WDTPeriphID2)

WDT0 base: 0x4000.0000

WDT1 base: 0x4000.1000

Offset 0xFE8

Type RO, reset 0x0000.0018

	31	30	29	28	27	26	25	24	23	22	21	20	19	18	17	16
	reserved															
Type	RO	RO	RO	RO	RO	RO	RO	RO	RO	RO	RO	RO	RO	RO	RO	RO
Reset	0	0	0	0	0	0	0	0	0	0	0	0	0	0	0	0
	15	14	13	12	11	10	9	8	7	6	5	4	3	2	1	0
	reserved								PID2							
Type	RO	RO	RO	RO	RO	RO	RO	RO	RO	RO	RO	RO	RO	RO	RO	RO
Reset	0	0	0	0	0	0	0	0	0	0	0	1	1	0	0	0

Bit/Field	Name	Type	Reset	Description
31:8	reserved	RO	0x0000.00	Software should not rely on the value of a reserved bit. To provide compatibility with future products, the value of a reserved bit should be preserved across a read-modify-write operation.
7:0	PID2	RO	0x18	Watchdog Peripheral ID Register [23:16]

Register 16: Watchdog Peripheral Identification 3 (WDTPeriphID3), offset 0xFEC

The **WDTPeriphIDn** registers are hard-coded and the fields within the register determine the reset value.

Watchdog Peripheral Identification 3 (WDTPeriphID3)

WDT0 base: 0x4000.0000

WDT1 base: 0x4000.1000

Offset 0xFEC

Type RO, reset 0x0000.0001

	31	30	29	28	27	26	25	24	23	22	21	20	19	18	17	16
	reserved															
Type	RO	RO	RO	RO	RO	RO	RO	RO	RO	RO	RO	RO	RO	RO	RO	RO
Reset	0	0	0	0	0	0	0	0	0	0	0	0	0	0	0	0
	15	14	13	12	11	10	9	8	7	6	5	4	3	2	1	0
	reserved								PID3							
Type	RO	RO	RO	RO	RO	RO	RO	RO	RO	RO	RO	RO	RO	RO	RO	RO
Reset	0	0	0	0	0	0	0	0	0	0	0	0	0	0	0	1

Bit/Field	Name	Type	Reset	Description
31:8	reserved	RO	0x0000.00	Software should not rely on the value of a reserved bit. To provide compatibility with future products, the value of a reserved bit should be preserved across a read-modify-write operation.
7:0	PID3	RO	0x01	Watchdog Peripheral ID Register [31:24]

Register 17: Watchdog PrimeCell Identification 0 (WDTPCellID0), offset 0xFF0

The **WDTPCellIDn** registers are hard-coded and the fields within the register determine the reset value.

Watchdog PrimeCell Identification 0 (WDTPCellID0)

WDT0 base: 0x4000.0000

WDT1 base: 0x4000.1000

Offset 0xFF0

Type RO, reset 0x0000.000D

	31	30	29	28	27	26	25	24	23	22	21	20	19	18	17	16
	reserved															
Type	RO	RO	RO	RO	RO	RO	RO	RO	RO	RO	RO	RO	RO	RO	RO	RO
Reset	0	0	0	0	0	0	0	0	0	0	0	0	0	0	0	0
	15	14	13	12	11	10	9	8	7	6	5	4	3	2	1	0
	reserved								CID0							
Type	RO	RO	RO	RO	RO	RO	RO	RO	RO	RO	RO	RO	RO	RO	RO	RO
Reset	0	0	0	0	0	0	0	0	0	0	0	0	1	1	0	1

Bit/Field	Name	Type	Reset	Description
31:8	reserved	RO	0x0000.00	Software should not rely on the value of a reserved bit. To provide compatibility with future products, the value of a reserved bit should be preserved across a read-modify-write operation.
7:0	CID0	RO	0x0D	Watchdog PrimeCell ID Register [7:0]

Register 18: Watchdog PrimeCell Identification 1 (WDTPCellID1), offset 0xFF4

The **WDTPCellIDn** registers are hard-coded and the fields within the register determine the reset value.

Watchdog PrimeCell Identification 1 (WDTPCellID1)

WDT0 base: 0x4000.0000
 WDT1 base: 0x4000.1000
 Offset 0xFF4
 Type RO, reset 0x0000.00F0

	31	30	29	28	27	26	25	24	23	22	21	20	19	18	17	16
	reserved															
Type	RO	RO	RO	RO	RO	RO	RO	RO	RO	RO	RO	RO	RO	RO	RO	RO
Reset	0	0	0	0	0	0	0	0	0	0	0	0	0	0	0	0
	15	14	13	12	11	10	9	8	7	6	5	4	3	2	1	0
	reserved								CID1							
Type	RO	RO	RO	RO	RO	RO	RO	RO	RO	RO	RO	RO	RO	RO	RO	RO
Reset	0	0	0	0	0	0	0	0	1	1	1	1	0	0	0	0

Bit/Field	Name	Type	Reset	Description
31:8	reserved	RO	0x0000.00	Software should not rely on the value of a reserved bit. To provide compatibility with future products, the value of a reserved bit should be preserved across a read-modify-write operation.
7:0	CID1	RO	0xF0	Watchdog PrimeCell ID Register [15:8]

Register 19: Watchdog PrimeCell Identification 2 (WDTPCellID2), offset 0xFF8

The **WDTPCellIDn** registers are hard-coded and the fields within the register determine the reset value.

Watchdog PrimeCell Identification 2 (WDTPCellID2)

WDT0 base: 0x4000.0000

WDT1 base: 0x4000.1000

Offset 0xFF8

Type RO, reset 0x0000.0006

	31	30	29	28	27	26	25	24	23	22	21	20	19	18	17	16
	reserved															
Type	RO	RO	RO	RO	RO	RO	RO	RO	RO	RO	RO	RO	RO	RO	RO	RO
Reset	0	0	0	0	0	0	0	0	0	0	0	0	0	0	0	0
	15	14	13	12	11	10	9	8	7	6	5	4	3	2	1	0
	reserved								CID2							
Type	RO	RO	RO	RO	RO	RO	RO	RO	RO	RO	RO	RO	RO	RO	RO	RO
Reset	0	0	0	0	0	0	0	0	0	0	0	0	0	1	1	0

Bit/Field	Name	Type	Reset	Description
31:8	reserved	RO	0x0000.00	Software should not rely on the value of a reserved bit. To provide compatibility with future products, the value of a reserved bit should be preserved across a read-modify-write operation.
7:0	CID2	RO	0x06	Watchdog PrimeCell ID Register [23:16]

Register 20: Watchdog PrimeCell Identification 3 (WDTPCellID3), offset 0xFFC

The **WDTPCellIDn** registers are hard-coded and the fields within the register determine the reset value.

Watchdog PrimeCell Identification 3 (WDTPCellID3)

WDT0 base: 0x4000.0000
 WDT1 base: 0x4000.1000
 Offset 0xFFC
 Type RO, reset 0x0000.00B1

	31	30	29	28	27	26	25	24	23	22	21	20	19	18	17	16
	reserved															
Type	RO	RO	RO	RO	RO	RO	RO	RO	RO	RO	RO	RO	RO	RO	RO	RO
Reset	0	0	0	0	0	0	0	0	0	0	0	0	0	0	0	0
	15	14	13	12	11	10	9	8	7	6	5	4	3	2	1	0
	reserved								CID3							
Type	RO	RO	RO	RO	RO	RO	RO	RO	RO	RO	RO	RO	RO	RO	RO	RO
Reset	0	0	0	0	0	0	0	0	1	0	1	1	0	0	0	1

Bit/Field	Name	Type	Reset	Description
31:8	reserved	RO	0x0000.00	Software should not rely on the value of a reserved bit. To provide compatibility with future products, the value of a reserved bit should be preserved across a read-modify-write operation.
7:0	CID3	RO	0xB1	Watchdog PrimeCell ID Register [31:24]

18 Analog-to-Digital Converter (ADC)

An analog-to-digital converter (ADC) is a peripheral that converts a continuous analog voltage to a discrete digital number. Two identical converter modules are included, which share 20 input channels.

The TM4C129ENCPDT ADC module features 12-bit conversion resolution and supports 20 input channels, plus an internal temperature sensor. Each ADC module contains four programmable sequencers allowing the sampling of multiple analog input sources without controller intervention. Each sample sequencer provides flexible programming with fully configurable input source, trigger events, interrupt generation, and sequencer priority. In addition, the conversion value can optionally be diverted to a digital comparator module. Each ADC module provides eight digital comparators. Each digital comparator evaluates the ADC conversion value against its two user-defined values to determine the operational range of the signal. The trigger source for ADC0 and ADC1 may be independent or the two ADC modules may operate from the same trigger source and operate on the same or different inputs. A phase shifter can delay the start of sampling by a specified phase angle. When using both ADC modules, it is possible to configure the converters to start the conversions coincidentally or within a relative phase from each other, see “Sample Phase Control” on page 1184.

The TM4C129ENCPDT microcontroller provides two ADC modules with each having the following features:

- 20 shared analog input channels
- 12-bit precision ADC
- Single-ended and differential-input configurations
- On-chip internal temperature sensor
- Maximum sample rate of two million samples/second
- Optional, programmable phase delay
- Sample and hold window programmability
- Four programmable sample conversion sequencers from one to eight entries long, with corresponding conversion result FIFOs
- Flexible trigger control
 - Controller (software)
 - Timers
 - Analog Comparators
 - PWM
 - GPIO
- Hardware averaging of up to 64 samples
- Eight digital comparators

- Converter uses signals V_{REFA+} and G_{NDA} as the voltage reference
- Power and ground for the analog circuitry is separate from the digital power and ground
- Efficient transfers using Micro Direct Memory Access Controller (μ DMA)
 - Dedicated channel for each sample sequencer
 - ADC module uses burst requests for DMA
- Global Alternate Clock (ALTCLK) resource or System Clock (SYSCLK) can be used to generate ADC clock

18.1 Block Diagram

The TM4C129ENC PDT microcontroller contains two identical Analog-to-Digital Converter modules. These two modules, ADC0 and ADC1, share the same 20 analog input channels. Each ADC module operates independently and can therefore execute different sample sequences, sample any of the analog input channels at any time, and generate different interrupts and triggers. Figure 18-1 on page 1178 shows how the two modules are connected to analog inputs and the system bus.

Figure 18-1. Implementation of Two ADC Blocks

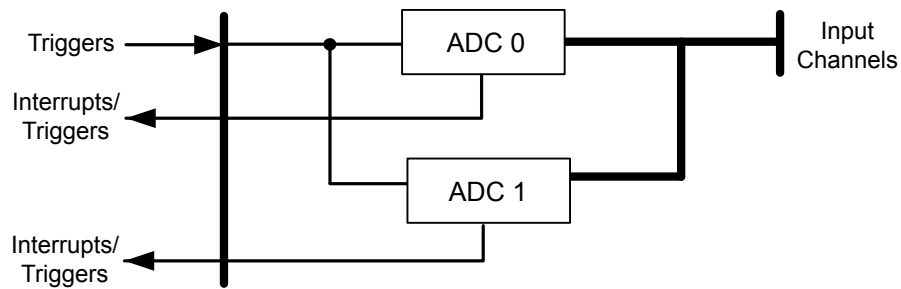
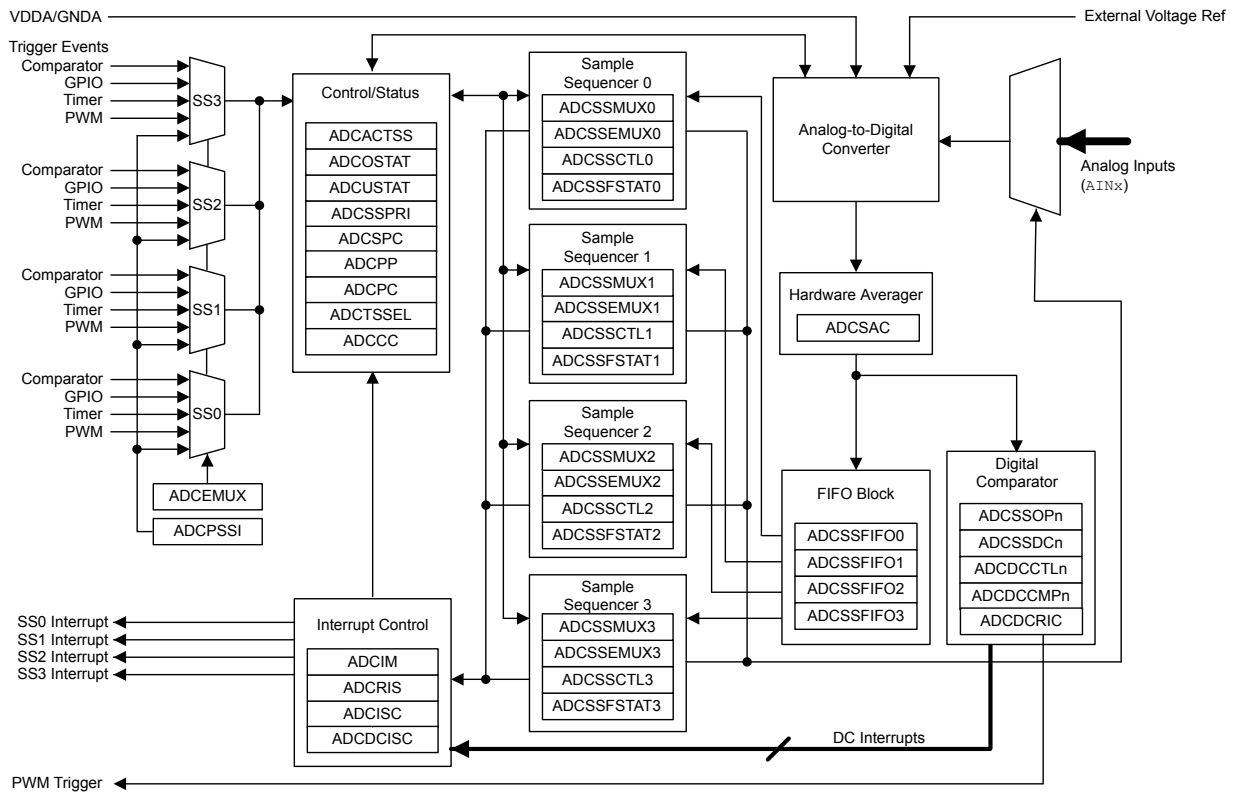

Figure 18-2 on page 1179 provides details on the internal configuration of the ADC controls and data registers.

Figure 18-2. ADC Module Block Diagram



18.2 Signal Description

The following table lists the external signals of the ADC module and describes the function of each. The AIN_x signals are analog functions for some GPIO signals. The column in the table below titled "Pin Mux/Pin Assignment" lists the GPIO pin placement for the ADC signals. These signals are configured by clearing the corresponding DEN bit in the **GPIO Digital Enable (GPIODEN)** register and setting the corresponding $AMSEL$ bit in the **GPIO Analog Mode Select (GPIOAMSEL)** register. For more information on configuring GPIOs, see "General-Purpose Input/Outputs (GPIOs)" on page 750. The V_{REFA+} signal (with the word "fixed" in the Pin Mux/Pin Assignment column) has a fixed pin assignment and function.

Table 18-1. ADC Signals (128TQFP)

Pin Name	Pin Number	Pin Mux / Pin Assignment	Pin Type	Buffer Type	Description
AIN0	12	PE3	I	Analog	Analog-to-digital converter input 0.
AIN1	13	PE2	I	Analog	Analog-to-digital converter input 1.
AIN2	14	PE1	I	Analog	Analog-to-digital converter input 2.
AIN3	15	PE0	I	Analog	Analog-to-digital converter input 3.
AIN4	128	PD7	I	Analog	Analog-to-digital converter input 4.
AIN5	127	PD6	I	Analog	Analog-to-digital converter input 5.
AIN6	126	PD5	I	Analog	Analog-to-digital converter input 6.
AIN7	125	PD4	I	Analog	Analog-to-digital converter input 7.

Table 18-1. ADC Signals (128TQFP) (continued)

Pin Name	Pin Number	Pin Mux / Pin Assignment	Pin Type	Buffer Type	Description
AIN8	124	PE5	I	Analog	Analog-to-digital converter input 8.
AIN9	123	PE4	I	Analog	Analog-to-digital converter input 9.
AIN10	121	PB4	I	Analog	Analog-to-digital converter input 10.
AIN11	120	PB5	I	Analog	Analog-to-digital converter input 11.
AIN12	4	PD3	I	Analog	Analog-to-digital converter input 12.
AIN13	3	PD2	I	Analog	Analog-to-digital converter input 13.
AIN14	2	PD1	I	Analog	Analog-to-digital converter input 14.
AIN15	1	PD0	I	Analog	Analog-to-digital converter input 15.
AIN16	18	PK0	I	Analog	Analog-to-digital converter input 16.
AIN17	19	PK1	I	Analog	Analog-to-digital converter input 17.
AIN18	20	PK2	I	Analog	Analog-to-digital converter input 18.
AIN19	21	PK3	I	Analog	Analog-to-digital converter input 19.
VREFA+	9	fixed	-	Analog	A reference voltage used to specify the voltage at which the ADC converts to a maximum value. This pin is used in conjunction with GND _A . The voltage that is applied to VREFA+ is the voltage with which an AIN _n signal is converted to 4095. The VREFA+ voltage is limited to the range specified in Table 30-44 on page 1985.

18.3 Functional Description

The TM4C129ENC_PDT ADC collects sample data by using a programmable sequence-based approach instead of the traditional single or double-sampling approaches found on many ADC modules. Each *sample sequence* is a fully programmed series of consecutive (back-to-back) samples, allowing the ADC to collect data from multiple input sources without having to be re-configured or serviced by the processor. The programming of each sample in the sample sequence includes parameters such as the input source and mode (differential versus single-ended input), interrupt generation on sample completion, and the indicator for the last sample in the sequence. In addition, the μ DMA can be used to more efficiently move data from the sample sequencers without CPU intervention.

18.3.1 Sample Sequencers

The sampling control and data capture is handled by the sample sequencers. All of the sequencers are identical in implementation except for the number of samples that can be captured and the depth of the FIFO. Table 18-2 on page 1180 shows the maximum number of samples that each sequencer can capture and its corresponding FIFO depth. Each sample that is captured is stored in the FIFO. In this implementation, each FIFO entry is a 32-bit word, with the lower 12 bits containing the conversion result.

Table 18-2. Samples and FIFO Depth of Sequencers

Sequencer	Number of Samples	Depth of FIFO
SS3	1	1
SS2	4	4
SS1	4	4
SS0	8	8

For a given sample sequence, each sample is defined by bit fields in the **ADC Sample Sequence Input Multiplexer Select (ADCSSMUXn)**, **ADC Sample Sequence Extended Input Multiplexer Select (ADCSEMUXn)** and **ADC Sample Sequence Control (ADCSSCTLn)** registers, where "n" corresponds to the sequence number. The **ADCSSMUXn** and **ADCSEMUXn** fields select the input pin, while the **ADCSSCTLn** fields contain the sample control bits corresponding to parameters such as temperature sensor selection, interrupt enable, end of sequence, and differential input mode. Sample sequencers are enabled by setting the respective **ASENn** bit in the **ADC Active Sample Sequencer (ADCACTSS)** register and should be configured before being enabled. Sampling is then initiated by setting the **SSn** bit in the **ADC Processor Sample Sequence Initiate (ADCPSSI)** register. In addition, sample sequences may be initiated on multiple ADC modules simultaneously using the **GSYNC** and **SYNCWAIT** bits in the **ADCPSSI** register during the configuration of each ADC module. For more information on using these bits, refer to page 1227.

When configuring a sample sequence, multiple uses of the same input pin within the same sequence are allowed. In the **ADCSSCTLn** register, the **IE_n** bits can be set for any combination of samples, allowing interrupts to be generated after every sample in the sequence if necessary. Also, the **END** bit can be set at any point within a sample sequence. For example, if Sequencer 0 is used, the **END** bit can be set in the nibble associated with the fifth sample, allowing Sequencer 0 to complete execution of the sample sequence after the fifth sample.

After a sample sequence completes execution, the result data can be retrieved from the **ADC Sample Sequence Result FIFO (ADCSSFIFO_n)** registers. The FIFOs are simple circular buffers that read a single address to "pop" result data. For software debug purposes, the positions of the FIFO head and tail pointers are visible in the **ADC Sample Sequence FIFO Status (ADCSSFSTAT_n)** registers along with **FULL** and **EMPTY** status flags. If a write is attempted when the FIFO is full, the write does not occur and an overflow condition is indicated. Overflow and underflow conditions are monitored using the **ADCOSTAT** and **ADCUSTAT** registers.

18.3.2 Module Control

Outside of the sample sequencers, the remainder of the control logic is responsible for tasks such as:

- Interrupt generation
- DMA operation
- Sequence prioritization
- Trigger configuration
- Comparator configuration
- External voltage reference
- Sample phase control
- Module clocking

18.3.2.1 Interrupts

The register configurations of the sample sequencers and digital comparators dictate which events generate raw interrupts, but do not have control over whether the interrupt is actually sent to the interrupt controller. The ADC module's interrupt signals are controlled by the state of the **MASK** bits in the **ADC Interrupt Mask (ADCIM)** register. Interrupt status can be viewed at two locations: the **ADC Raw Interrupt Status (ADCRIS)** register, which shows the raw status of the various interrupt

signals; and the **ADC Interrupt Status and Clear (ADCISC)** register, which shows active interrupts that are enabled by the **ADCIM** register. Sequencer interrupts are cleared by writing a 1 to the corresponding **IN** bit in **ADCISC**. Digital comparator interrupts are cleared by writing a 1 to the **ADC Digital Comparator Interrupt Status and Clear (ADCDCISC)** register.

18.3.2.2 DMA Operation

DMA may be used to increase efficiency by allowing each sample sequencer to operate independently and transfer data without processor intervention or reconfiguration.

The ADC asserts single and burst μ DMA request signals (`dma_sreq` and `dma_req`) to the μ DMA controller based on the FIFO level. The `dma_req` signal is generated when the FIFO in question is half-full (that is, at 4 samples for SS0, 2 samples for SS1 and SS2, and at 1 sample for SS3). If, for example, the **ADCSSCTL0** register has six samples to transfer, a burst of four values occurs followed by two single transfers (`dma_sreq`). The `dma_done` signals (one per sample sequencer) are sent to the ADC to allow for a triggering of **DMAINRn** interrupt bits in the **ADCRIS** register. The μ DMA is enabled for a specific sample sequencer by setting the appropriate **ADENn** bit in the **ADCACTSS** register at offset 0x000.

To use the μ DMA with the ADC module, the application must enable the ADC channel through **DMA Channel Map Select n (DMACHMAPn)** register in the μ DMA.

Refer to the “Micro Direct Memory Access (μ DMA)” on page 686 for more details about programming the μ DMA controller.

18.3.2.3 Prioritization

When sampling events (triggers) happen concurrently, they are prioritized for processing by the values in the **ADC Sample Sequencer Priority (ADCSSPRI)** register. Valid priority values are in the range of 0-3, with 0 being the highest priority and 3 being the lowest. Multiple active sample sequencer units with the same priority do not provide consistent results, so software must ensure that all active sample sequencer units have a unique priority value.

18.3.2.4 Sampling Events

Sample triggering for each sample sequencer is defined in the **ADC Event Multiplexer Select (ADCEMUX)** register. Trigger sources include processor (default), analog comparators, an external signal on a GPIO specified by the **GPIO ADC Control (GPIOADCCTL)** register, a GP Timer, a PWM generator, and continuous sampling. The processor triggers sampling by setting the **SSx** bits in the **ADC Processor Sample Sequence Initiate (ADCPSSI)** register.

Care must be taken when using the continuous sampling trigger. If a sequencer's priority is too high, it is possible to starve other lower priority sequencers. Generally, a sample sequencer using continuous sampling should be set to the lowest priority. Continuous sampling can be used with a digital comparator to cause an interrupt when a particular voltage is seen on an input.

18.3.2.5 Sample and Hold Window Control

The ADC module provides the capability of programming the sample and hold window of each step in a sequence through the **ADC Sample Sequence n Sample and Hold Time (ADCSSSTSHn)** register. Each **TSHn** field can be written with a different sample and hold width, which is represented in ADC clocks. The table below gives the allowed encodings:

Table 18-3. Sample and Hold Width in ADC Clocks

TSHn Encoding	N _{SH}
0x0	4

Table 18-3. Sample and Hold Width in ADC Clocks (continued)

TSHn Encoding	N _{SH}
0x1	reserved
0x2	8
0x3	reserved
0x4	16
0x5	reserved
0x6	32
0x7	reserved
0x8	64
0x9	reserved
0xA	128
0xB	reserved
0xC	256
0xD-0xF	reserved

The ADC conversion frequency is a function of the Sample and Hold number, given by the following equation:

$$F_{\text{CONV}} = 1 / ((N_{\text{SH}} + 12) * T_{\text{ADC}})$$

where:

- N_{SH} is the sample and hold width in ADC clocks
- T_{ADC} is the ADC conversion clock period, which is the inverse of the ADC clock frequency F_{ADC}

Now, the maximum allowable external source resistance (R_S) also changes with the value of N_{SH}, as the total settling time of the input circuitry must be fast enough to settle to within the ADC resolution in a single sampling interval. The input circuitry includes the external source resistance as well as the input resistance and capacitance of the ADC (R_{ADC} and C_{ADC}).

The values for R_S and F_{CONV} for varying N_{SH} values, with F_{ADC}=16MHz and F_{ADC}=32MHz are given in tables 18-4-a and 18-4-b. The system designer must take into consideration both of these factors for optimal ADC operation.

Table 18-4. R_S and F_{CONV} Values with Varying N_{SH} Values and F_{ADC} = 16 MHz

N _{SH} (Cycles)	4	8	16	32	64	128	256
F _{CONV} (Ksps)	1000	800	571	364	211	114	60
R _S Max (Ω)	500	3500	9500	21500	45500	93500	189500

Table 18-5. R_S and F_{CONV} Values with Varying N_{SH} Values and F_{ADC} = 32 MHz

N _{SH} (Cycles)	4	8	16	32	64	128	256
F _{CONV} (Ksps)	2000	1600	1143	727	421	229	119
R _S Max (Ω)	250	500	3500	9500	21500	45500	93500

18.3.2.6 Sample Phase Control

The trigger source for ADC0 and ADC1 may be independent or the two ADC modules may operate from the same trigger source and operate on the same or different inputs. If the converters are running at the same sample rate, they may be configured to start the conversions coincidentally or one ADC may be programmed to lag up to 15 clock cycles relative to the other ADC. The sample time can be delayed from the standard sampling time by programming the `PHASE` field in the **ADC Sample Phase Control (ADCSPC)** register. Figure 18-3 on page 1184 shows an example of various phase relationships.

Figure 18-3. ADC Sample Phases

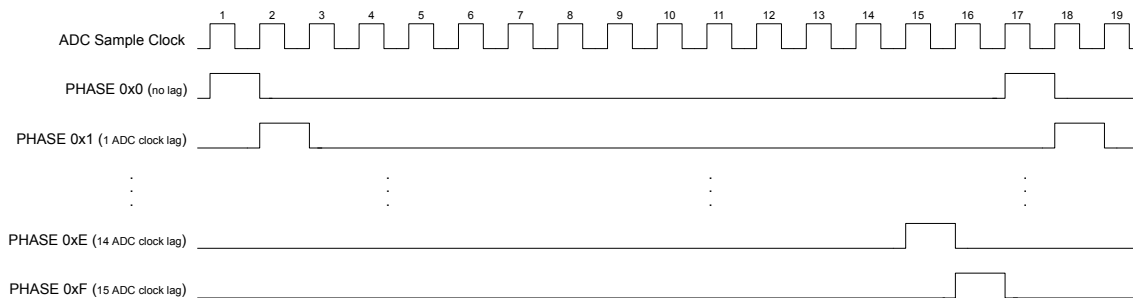

This feature can be used to double the sampling rate of an input. Both ADC Module 0 and ADC Module 1 can be programmed to sample the same input. ADC module 0 can sample at the standard position (the `PHASE` field in the **ADCSPC** register is 0x0). ADC Module 1 can be configured to sample with a phase lag (`PHASE` is nonzero). For a sample rate of two million samples/second at 16MHz, the `TSHn` field of all of the sequencer samples of both ADCs must be programmed to 0x0 and the `PHASE` field of one of the ADC modules must be set to 0x8. The two modules can be synchronized using the `GSYNC` and `SYNCWAIT` bits in the **ADC Processor Sample Sequence Initiate (ADCPSSI)** register. Software can then combine the results from the two modules to create a sample rate of two million samples/second at 16MHz as shown in Figure 18-4 on page 1184.

Figure 18-4. Doubling the ADC Sample Rate

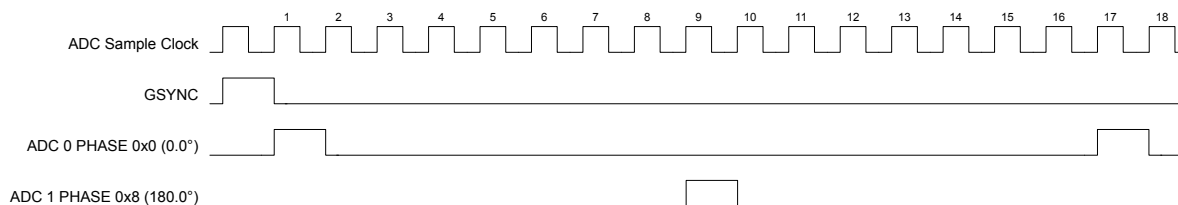

Using the **ADCSPC** register, ADC0 and ADC1 may provide a number of interesting applications:

- Coincident continuous sampling of different signals. The sample sequence steps run coincidentally in both converters. In this situation, the `TSHn` of matching sample steps of both ADC module sequencers must be the same and the `PHASE` field must be 0x0 in both ADC module **ADCSPC** registers. The `TSHn` field is found in the **ADC Sample Sequence n Sample and Hold Time (ADCSSTSHn)** register.
 - ADC Module 0, **ADCSPC** = 0x0, sampling `AIN0`

- ADC Module 1, **ADCSPC** = 0x0, sampling **AIN1**

Note: If two ADCs are configured to sample the same signal, a skew (phase lag) must be added to one of the ADC modules to prevent coincident sampling. Phase lag can be added by programming the **PHASE** field in the **ADCSPC** register.

- Skewed sampling of the same signal. The skew is determined by both the **TSHn** field in the **ADCSSTSHn** registers and the **PHASE** field in the **ADCSPC** register. For the fastest skewed sample rate, all **TSHn** fields must be programmed to 0x0. If **TSHn**=0x0 for all sequencers and the **PHASE** field of one ADC is 0x8, the configuration doubles the conversion bandwidth of a single input when software combines the results as shown in Figure 18-5 on page 1185.

- ADC Module 0, **ADCSPC** = 0x0, sampling **AIN0**

- ADC Module 1, **ADCSPC** = 0x8, sampling **AIN0**

Note that it is not required that the **TSHn** fields be the same in a skewed sample. If an application has varying analog input resistance, then **TSHn** and **PHASE** may vary according to operational requirements.

Figure 18-5. Skewed Sampling

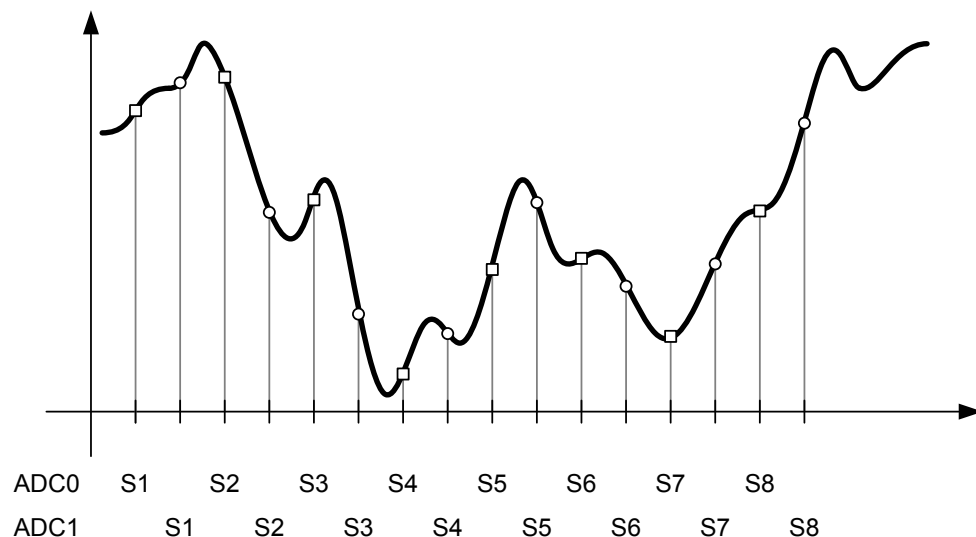

18.3.2.7 Module Clocking

The ADC digital block is clocked by the system clock and the ADC analog block is clocked from a separate conversion clock (ADC Clock). The ADC clock frequency can be up to 32 MHz to generate a conversion rate of 2 Msps. A 16 MHz ADC clock provides a 1 Msps sampling rate. There are three sources of the ADC clock:

- Divided PLL VCO. The PLL VCO frequency can be configured to generate up to a 32-MHz clock for a conversion rate of 2 Msps. The **CS** field in the **ADCCC** register must be programmed to 0x0 to select the PLL VCO and the **CLKDIV** field is used to set the appropriate clock divisor for the desired frequency.

- 16 MHz PIOSC. Using the PIOSC provides a conversion rate near 1 Msps. To use the PIOSC to clock the ADC, first power up the PLL and then enable the PIOSC in the CS bit field in the **ADCCC** register, then disable the PLL.
- MOSC. The MOSC clock source must be 16 MHz for a 1 Msps conversion rate and 32 MHz for a 2 Msps conversion rate.

The system clock must be at the same frequency or higher than the ADC clock. All ADC modules share the same clock source to facilitate the synchronization of data samples between conversion units, the selection and programming of which is provided by ADC0's **ADCCC** register. The ADC modules do not run at different conversion rates.

18.3.2.8 Busy Status

The **BUSY** bit of the **ADCACTSS** register is used to indicate when the ADC is busy with a current conversion. When there are no triggers pending which may start a new conversion in the immediate cycle or next few cycles, the **BUSY** bit reads as 0. Software must read the status of the **BUSY** bit as clear before disabling the ADC clock by writing to the **Analog-to-Digital Converter Run Mode Clock Gating Control (RCGCADC)** register.

18.3.3 Hardware Sample Averaging Circuit

Higher precision results can be generated using the hardware averaging circuit, however, the improved results are at the cost of throughput. Up to 64 samples can be accumulated and averaged to form a single data entry in the sequencer FIFO. Throughput is decreased proportionally to the number of samples in the averaging calculation. For example, if the averaging circuit is configured to average 16 samples, the throughput is decreased by a factor of 16.

By default the averaging circuit is off, and all data from the converter passes through to the sequencer FIFO. The averaging hardware is controlled by the **ADC Sample Averaging Control (ADCSAC)** register (see page 1229). A single averaging circuit has been implemented, thus all input channels receive the same amount of averaging whether they are single-ended or differential.

Figure 18-6 shows an example in which the **ADCSAC** register is set to 0x2 for 4x hardware oversampling and the **IE1** bit is set for the sample sequence, resulting in an interrupt after the second averaged value is stored in the FIFO.

Figure 18-6. Sample Averaging Example

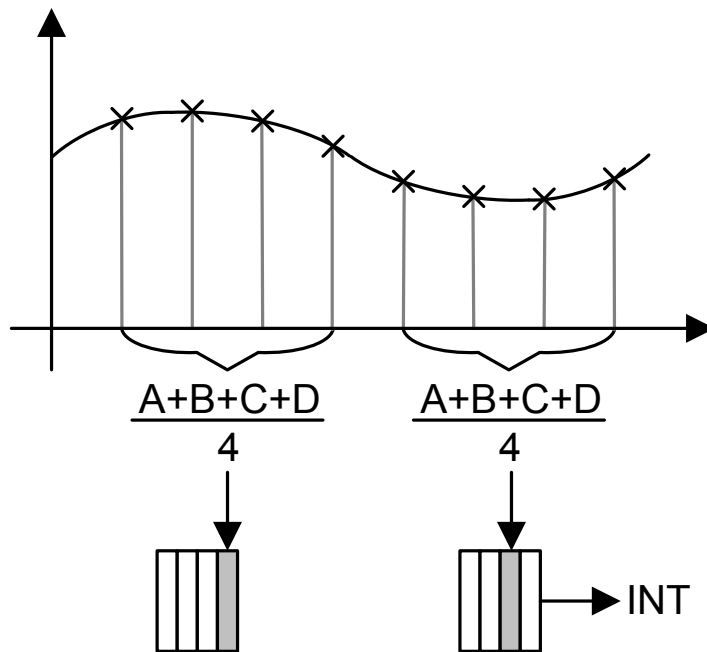

18.3.4 Analog-to-Digital Converter

The Analog-to-Digital Converter (ADC) module uses a Successive Approximation Register (SAR) architecture to deliver a 12-bit, low-power, high-precision conversion value. The successive approximation uses a switched capacitor array to perform the dual functions of sampling and holding the signal as well as providing the 12-bit DAC operation.

Figure 18-7 shows the ADC input equivalency diagram; for parameter values, see “Analog-to-Digital Converter (ADC)” on page 1985.

Figure 18-7. ADC Input Equivalency

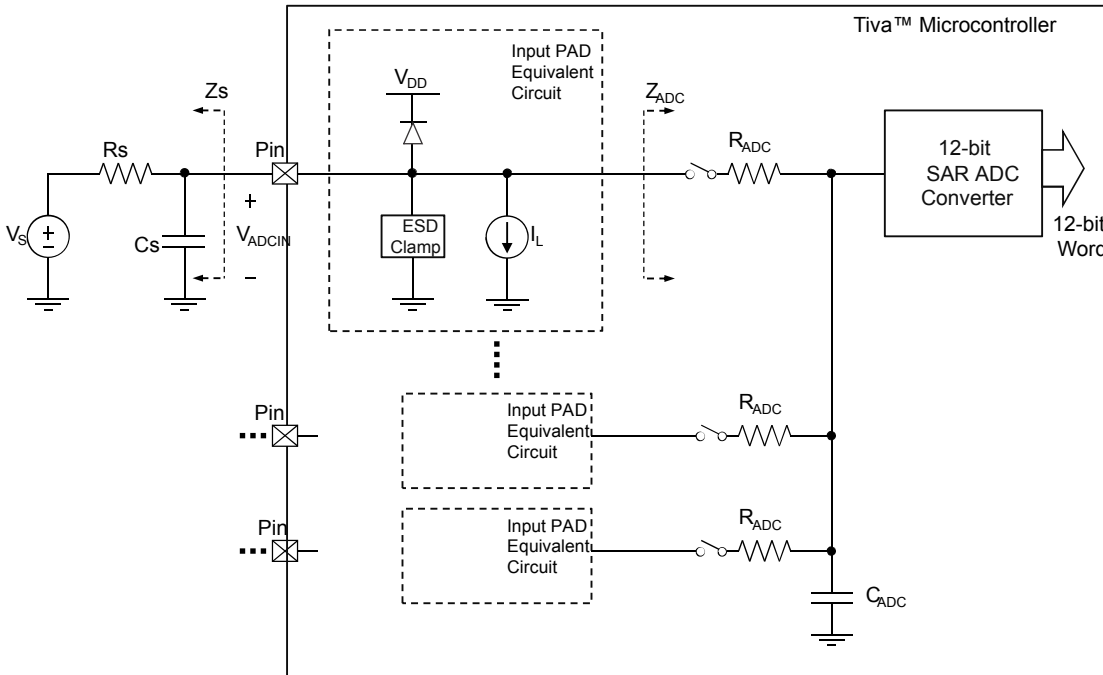

The ADC operates from both the 3.3-V analog and 1.2-V digital power supplies. The ADC clock can be configured to reduce power consumption when ADC conversions are not required (see “System Control” on page 246). The analog inputs are connected to the ADC through specially balanced input paths to minimize the distortion and cross-talk on the inputs. Detailed information on the ADC power supplies and analog inputs can be found in “Analog-to-Digital Converter (ADC)” on page 1985.

18.3.4.1 Voltage Reference

The ADC uses internal signals VREFP and VREFN as references to produce a conversion value from the selected analog input. VREFP can be connected to either VREFA+ or VDDA and VREFN is connected to GNDA as configured by the VREF bit in the **ADC Control (ADCCTL)** register, as shown in Figure 18-8.

Figure 18-8. ADC Voltage Reference

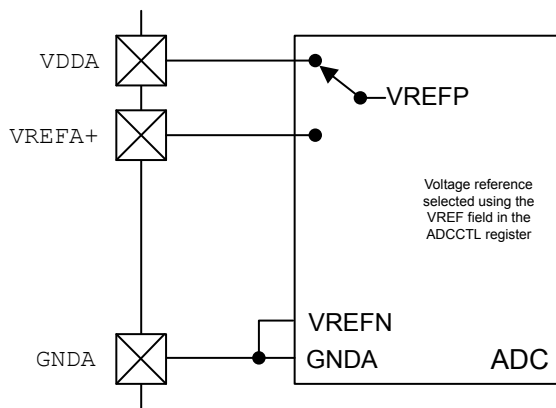

The range of this conversion value is from 0x000 to 0xFFFF. In single-ended-input mode, the 0x000 value corresponds to the voltage level on VREFN; the 0xFFFF value corresponds to the voltage level on VREFP. This configuration results in a resolution that can be calculated using the following equation:

$$\text{mV per ADC code} = (\text{VREFP} - \text{VREFN}) / 4096$$

While the analog input pads can handle voltages beyond this range, the analog input voltages must remain within the limits prescribed by Table 30-44 on page 1985 to produce accurate results. The $V_{\text{REFA+}}$ specification defines the useful range for the external voltage reference on VREFA+ and GND_A, see Table 30-44 on page 1985. Care must be taken to supply a reference voltage of acceptable quality. Figure 18-9 on page 1189 shows the ADC conversion function of the analog inputs.

Figure 18-9. ADC Conversion Result

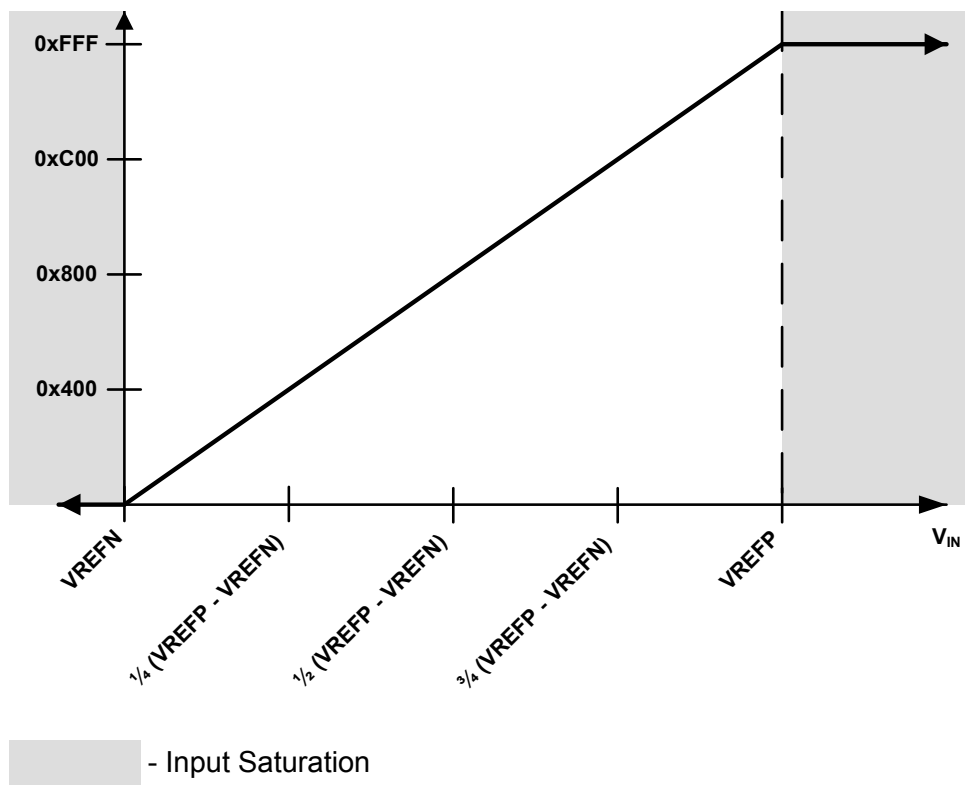

18.3.5 Differential Sampling

In addition to traditional single-ended sampling, the ADC module supports differential sampling of two analog input channels. To enable differential sampling, software must set the D_n bit in the **ADCSSCTL0n** register in a step's configuration nibble.

When a sequence step is configured for differential sampling, the input pair to sample must be configured in the **ADCSSMUXn** register. Differential pair 0 samples analog inputs 0 and 1; differential

pair 1 samples analog inputs 2 and 3; and so on (see Table 18-6 on page 1190). The ADC does not support other differential pairings such as analog input 0 with analog input 3.

Table 18-6. Differential Sampling Pairs

Differential Pair	Analog Inputs
0	0 and 1
1	2 and 3
2	4 and 5
3	6 and 7
4	8 and 9
5	10 and 11
6	12 and 13
7	14 and 15
8	16 and 17
9	18 and 19

The voltage sampled in differential mode is the difference between the odd and even channels:

- Input Positive Voltage: $V_{IN+} = V_{IN_EVEN}$ (even channel)
- Input Negative Voltage: $V_{IN-} = V_{IN_ODD}$ (odd channel)

The input differential voltage is defined as: $V_{IN_D} = V_{IN+} - V_{IN-}$, therefore:

- If $V_{IN_D} = 0$, then the conversion result = 0x800
- If $V_{IN_D} > 0$, then the conversion result $> 0x800$ (range is 0x800–0xFFF)
- If $V_{IN_D} < 0$, then the conversion result $< 0x800$ (range is 0–0x800)

When using differential sampling, the following definitions are relevant:

- Input Common Mode Voltage: $V_{IN_{CM}} = (V_{IN+} + V_{IN-}) / 2$
- Reference Positive Voltage: V_{REFP}
- Reference Negative Voltage: V_{REFN}
- Reference Differential Voltage: $V_{REF_D} = V_{REFP} - V_{REFN}$
- Reference Common Mode Voltage: $V_{REF_{CM}} = (V_{REFP} + V_{REFN}) / 2$

The following conditions provide optimal results in differential mode:

- Both V_{IN_EVEN} and V_{IN_ODD} must be in the range of (V_{REFP} to V_{REFN}) for a valid conversion result
- The maximum possible differential input swing, or the maximum differential range, is: $-V_{REF_D}$ to $+V_{REF_D}$, so the maximum peak-to-peak input differential signal is $(+V_{REF_D} - -V_{REF_D}) = 2 * V_{REF_D} = 2 * (V_{REFP} - V_{REFN})$

- In order to take advantage of the maximum possible differential input swing, $V_{IN_{CM}}$ should be very close to $V_{REF_{CM}}$, see Table 30-44 on page 1985.

If $V_{IN_{CM}}$ is not equal to $V_{REF_{CM}}$, the differential input signal may clip at either maximum or minimum voltage, because either single ended input can never be larger than V_{REFP} or smaller than V_{REFN} , and it is not possible to achieve full swing. Thus any difference in common mode between the input voltage and the reference voltage limits the differential dynamic range of the ADC.

Because the maximum peak-to-peak differential signal voltage is $2 * (V_{REFP} - V_{REFN})$, the ADC codes are interpreted as:

$$\text{mV per ADC code} = (2 * (V_{REFP} - V_{REFN})) / 4096$$

Figure 18-10 shows how the differential voltage, ΔV , is represented in ADC codes.

Figure 18-10. Differential Voltage Representation

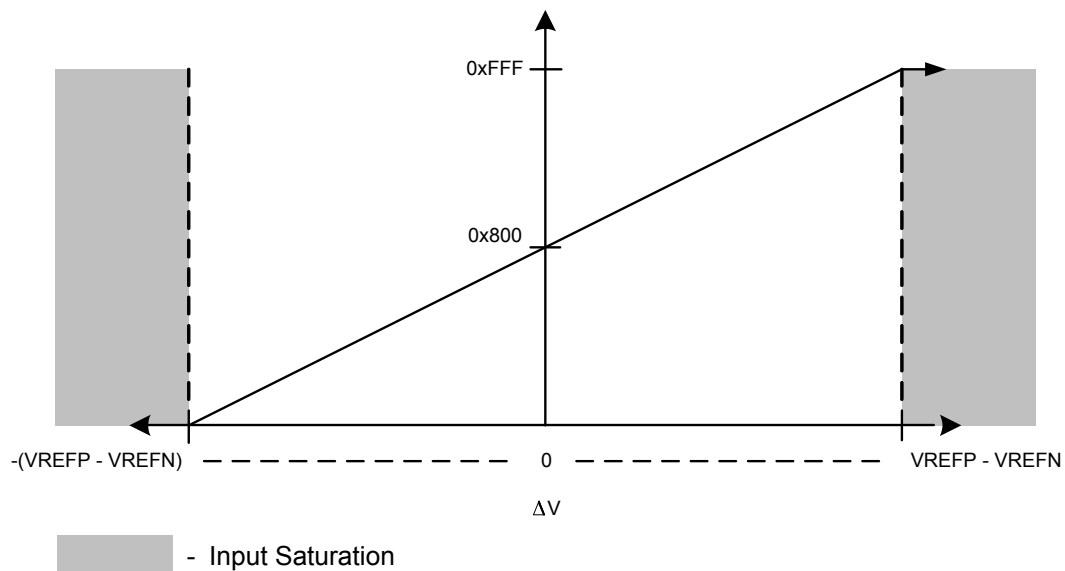

18.3.6 Internal Temperature Sensor

The temperature sensor serves two primary purposes: 1) to notify the system that internal temperature is too high or low for reliable operation and 2) to provide temperature measurements for calibration of the Hibernate module RTC trim value.

The temperature sensor does not have a separate enable, because it also contains the bandgap reference and must always be enabled. The reference is supplied to other analog modules; not just the ADC. In addition, the temperature sensor has a second power-down input in the 3.3 V domain which provides control by the Hibernation module.

The internal temperature sensor converts a temperature measurement into a voltage. This voltage value, V_{TSENS} , is given by the following equation (where TEMP is the temperature in °C):

$$V_{TSENS} = 2.7 - ((TEMP + 55) / 75)$$

This relation is shown in Figure 18-11 on page 1192.

Figure 18-11. Internal Temperature Sensor Characteristic

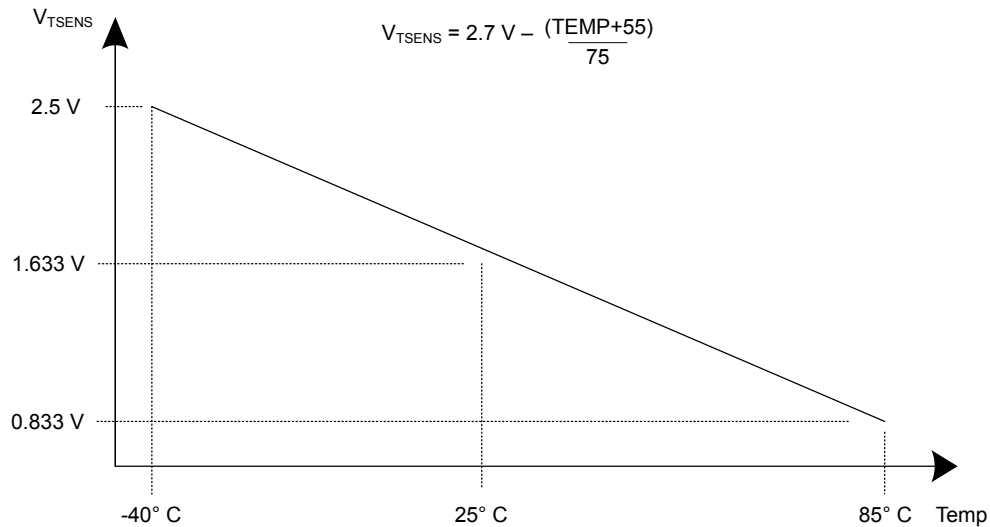

The temperature sensor reading can be sampled in a sample sequence by setting the TS_n bit in the **ADCSCTLn** register. The sample and hold width should be configured for at least 16 ADC clocks using the **ADCSSTSHn** register. The temperature reading from the temperature sensor can also be given as a function of the ADC value. The following formula calculates temperature (TEMP in °C) based on the ADC reading (ADC_{CODE} , given as an unsigned decimal number from 0 to 4095) and the maximum ADC voltage range ($V_{REFP} - V_{REFN}$):

$$TEMP = 147.5 - ((75 * (V_{REFP} - V_{REFN}) * ADC_{CODE}) / 4096)$$

18.3.7 Digital Comparator Unit

An ADC is commonly used to sample an external signal and to monitor its value to ensure that it remains in a given range. To automate this monitoring procedure and reduce the amount of processor overhead that is required, each module provides eight digital comparators.

Conversions from the ADC that are sent to the digital comparators are compared against the user programmable limits in the **ADC Digital Comparator Range (ADCDCMPn)** registers. The ADC can be configured to generate an interrupt depending on whether the ADC is operating within the low, mid or high-band region configured in the $ADCDCMP_n$ bit fields. The digital comparators four operational modes (Once, Always, Hysteresis Once, Hysteresis Always) can be additionally applied to the interrupt configuration.

18.3.7.1 Output Functions

ADC conversions can either be stored in the ADC Sample Sequence FIFOs or compared using the digital comparator resources as defined by the S_nDCOP bits in the **ADC Sample Sequence n Operation (ADCSOPn)** register. These selected ADC conversions are used by their respective digital comparator to monitor the external signal. Each comparator has two possible output functions: processor interrupts and triggers.

Each function has its own state machine to track the monitored signal. Even though the interrupt and trigger functions can be enabled individually or both at the same time, the same conversion

data is used by each function to determine if the right conditions have been met to assert the associated output.

Interrupts

The digital comparator interrupt function is enabled by setting the `CIE` bit in the **ADC Digital Comparator Control (ADCDCCTLn)** register. This bit enables the interrupt function state machine to start monitoring the incoming ADC conversions. When the appropriate set of conditions is met, and the `DCONSSx` bit is set in the **ADCIM** register, an interrupt is sent to the interrupt controller.

Note: For a 1 to 2 Msps rate, as the system clock frequency approaches the ADC clock frequency, it is recommended that the application use the μ DMA to store conversion data from the FIFO to memory before processing rather than an interrupt-driven single data read. Using the μ DMA to store multiple samples before interrupting the processor amortizes interrupt overhead across multiple transfers and prevents loss of sample data.

Note: Only a single `DCONSSn` bit should be set at any given time. Setting more than one of these bits results in the `INRDC` bit from the **ADCRIS** register being masked, and no interrupt is generated on any of the sample sequencer interrupt lines. It is recommended that when interrupts are used, they are enabled on alternating samples or at the end of the sample sequence.

Triggers

The digital comparator trigger function is enabled by setting the `CTE` bit in the **ADCDCCTLn** register. This bit enables the trigger function state machine to start monitoring the incoming ADC conversions. When the appropriate set of conditions is met, the corresponding digital comparator trigger to the PWM module is asserted.

18.3.7.2 Operational Modes

Four operational modes are provided to support a broad range of applications and multiple possible signaling requirements: Always, Once, Hysteresis Always, and Hysteresis Once. The operational mode is selected using the `CIM` or `CTM` field in the **ADCDCCTLn** register.

Always Mode

In the Always operational mode, the associated interrupt or trigger is asserted whenever the ADC conversion value meets its comparison criteria. The result is a string of assertions on the interrupt or trigger while the conversions are within the appropriate range.

Once Mode

In the Once operational mode, the associated interrupt or trigger is asserted whenever the ADC conversion value meets its comparison criteria, and the previous ADC conversion value did not. The result is a single assertion of the interrupt or trigger when the conversions are within the appropriate range.

Hysteresis-Always Mode

The Hysteresis-Always operational mode can only be used in conjunction with the low-band or high-band regions because the mid-band region must be crossed and the opposite region entered to clear the hysteresis condition. In the Hysteresis-Always mode, the associated interrupt or trigger is asserted in the following cases: 1) the ADC conversion value meets its comparison criteria or 2) a previous ADC conversion value has met the comparison criteria, and the hysteresis condition has not been cleared by entering the opposite region. The result is a string of assertions on the interrupt or trigger that continue until the opposite region is entered.

Hysteresis-Once Mode

The Hysteresis-Once operational mode can only be used in conjunction with the low-band or high-band regions because the mid-band region must be crossed and the opposite region entered to clear the hysteresis condition. In the Hysteresis-Once mode, the associated interrupt or trigger is asserted only when the ADC conversion value meets its comparison criteria, the hysteresis condition is clear, and the previous ADC conversion did not meet the comparison criteria. The result is a single assertion on the interrupt or trigger.

18.3.7.3 Function Ranges

The two comparison values, COMP0 and COMP1, in the **ADC Digital Comparator Range (ADCDCMPn)** register effectively break the conversion area into three distinct regions. These regions are referred to as the low-band (less than COMP0), mid-band (greater than COMP0 but less than or equal to COMP1), and high-band (greater than or equal to COMP1) regions. COMP0 and COMP1 may be programmed to the same value, effectively creating two regions, but COMP1 must always be greater than or equal to the value of COMP0. A COMP1 value that is less than COMP0 generates unpredictable results.

Low-Band Operation

To operate in the low-band region, the CIC field or the CTC field in the **ADCDCCTLn** register must be programmed to 0x0. This setting causes interrupts or triggers to be generated in the low-band region as defined by the programmed operational mode. An example of the state of the interrupt/trigger signal in the low-band region for each of the operational modes is shown in Figure 18-12 on page 1194. Note that a "0" in a column following the operational mode name (Always, Once, Hysteresis Always, and Hysteresis Once) indicates that the interrupt or trigger signal is deasserted and a "1" indicates that the signal is asserted.

Figure 18-12. Low-Band Operation (CIC=0x0 and/or CTC=0x0)

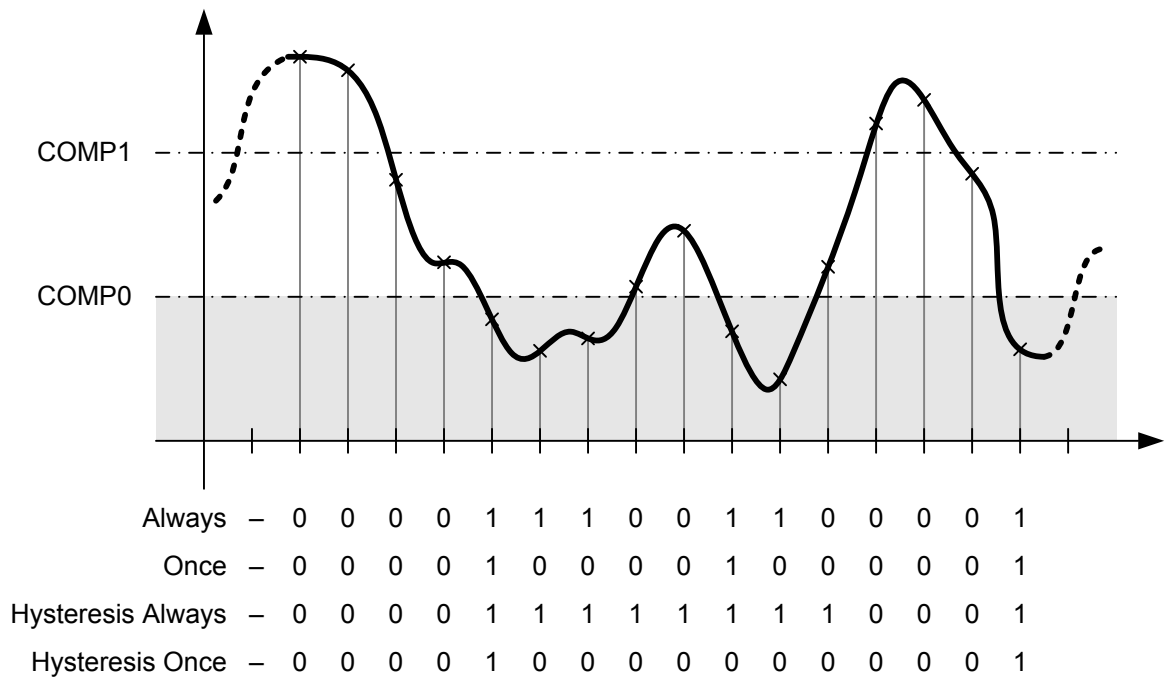

Mid-Band Operation

To operate in the mid-band region, the `CIC` field or the `CTC` field in the `ADCDCCTLn` register must be programmed to `0x1`. This setting causes interrupts or triggers to be generated in the mid-band region according to the operation mode. Only the Always and Once operational modes are available in the mid-band region. An example of the state of the interrupt/trigger signal in the mid-band region for each of the allowed operational modes is shown in Figure 18-13 on page 1195. Note that a "0" in a column following the operational mode name (Always or Once) indicates that the interrupt or trigger signal is deasserted and a "1" indicates that the signal is asserted.

Figure 18-13. Mid-Band Operation (CIC=0x1 and/or CTC=0x1)

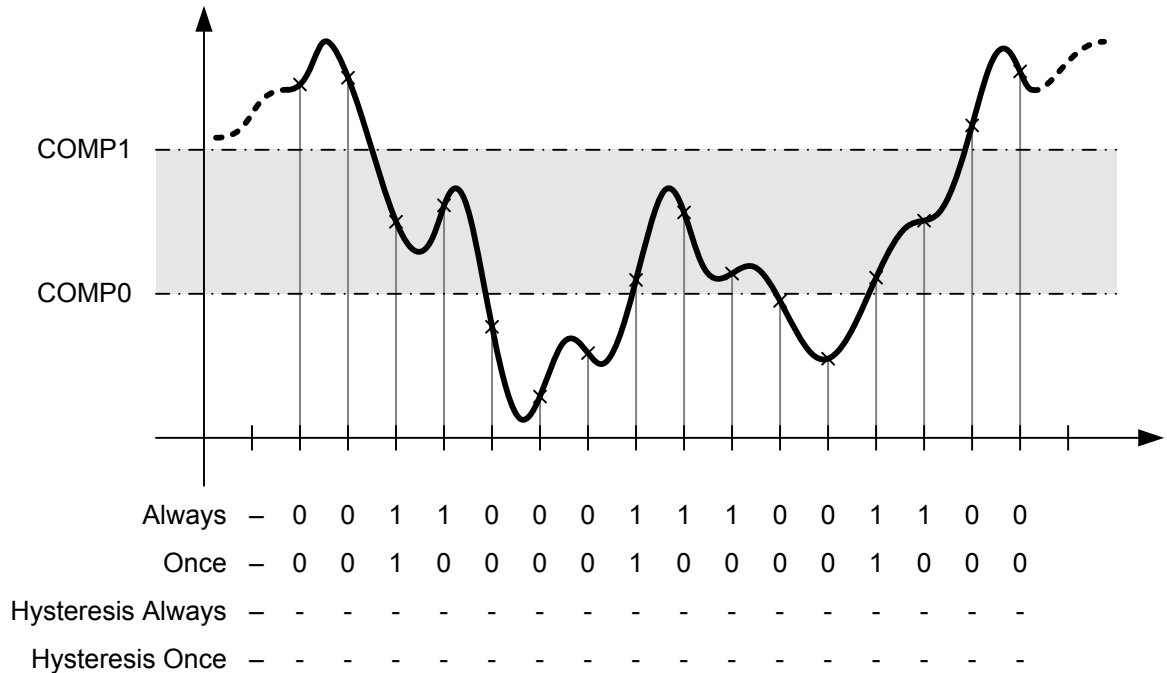

High-Band Operation

To operate in the high-band region, the `CIC` field or the `CTC` field in the `ADCDCCTLn` register must be programmed to `0x3`. This setting causes interrupts or triggers to be generated in the high-band region according to the operation mode. An example of the state of the interrupt/trigger signal in the high-band region for each of the allowed operational modes is shown in Figure 18-14 on page 1196. Note that a "0" in a column following the operational mode name (Always, Once, Hysteresis Always, and Hysteresis Once) indicates that the interrupt or trigger signal is deasserted and a "1" indicates that the signal is asserted.

Figure 18-14. High-Band Operation (CIC=0x3 and/or CTC=0x3)

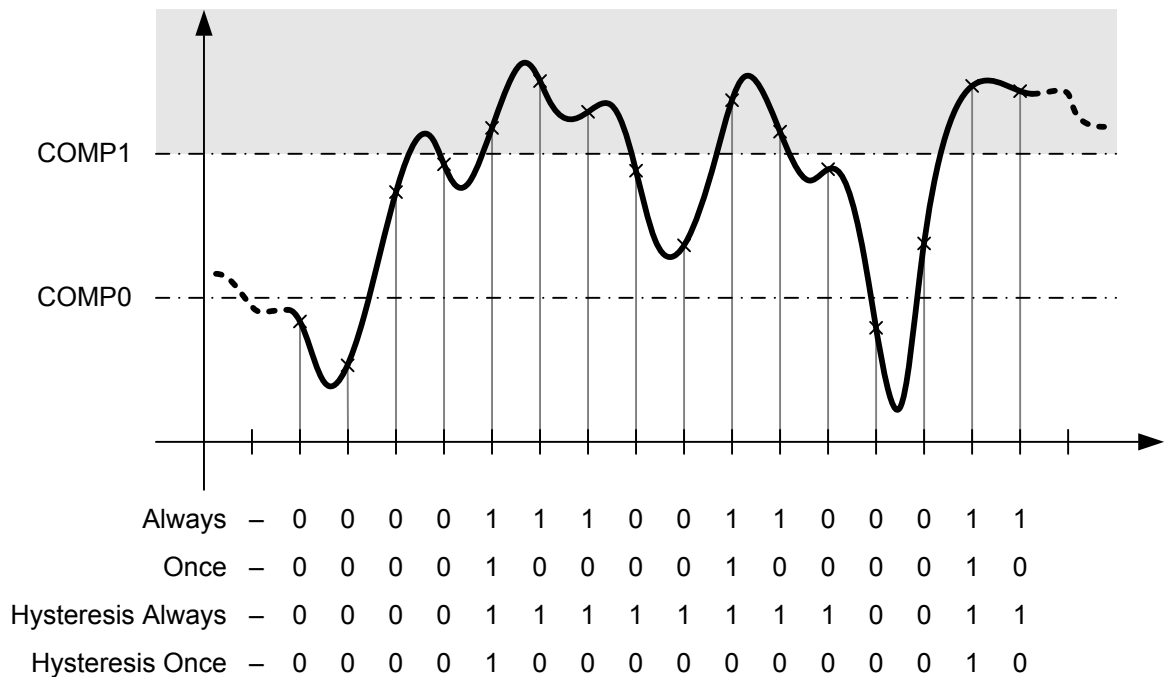

18.4 Initialization and Configuration

18.4.1 Module Initialization

Initialization of the ADC module is a simple process with very few steps: enabling the clock to the ADC, disabling the analog isolation circuit associated with all inputs that are to be used, and reconfiguring the sample sequencer priorities (if needed).

The initialization sequence for the ADC is as follows:

1. Enable the ADC clock using the **RCGCADC** register (see page 403).
2. Enable the clock to the appropriate GPIO modules via the **RCGCGPIO** register (see page 389). To find out which GPIO ports to enable, refer to “Signal Description” on page 1179.
3. Set the GPIO **AFSEL** bits for the ADC input pins (see page 778). To determine which GPIOs to configure, see Table 29-4 on page 1921.
4. Configure the **AIN_x** signals to be analog inputs by clearing the corresponding **DEN** bit in the **GPIO Digital Enable (GPIODEN)** register (see page 789).
5. Disable the analog isolation circuit for all ADC input pins that are to be used by writing a 1 to the appropriate bits of the **GPIOAMSEL** register (see page 794) in the associated GPIO block.
6. If required by the application, reconfigure the sample sequencer priorities in the **ADCSSPRI** register. The default configuration has Sample Sequencer 0 with the highest priority and Sample Sequencer 3 as the lowest priority.

18.4.2 Sample Sequencer Configuration

Configuration of the sample sequencers is slightly more complex than the module initialization because each sample sequencer is completely programmable.

The configuration for each sample sequencer should be as follows:

1. Ensure that the sample sequencer is disabled by clearing the corresponding `ASENn` bit in the **ADCACTSS** register. Programming of the sample sequencers is allowed without having them enabled. Disabling the sequencer during programming prevents erroneous execution if a trigger event were to occur during the configuration process.
2. Configure the trigger event for the sample sequencer in the **ADCEMUX** register.
3. When using a PWM generator as the trigger source, use the **ADC Trigger Source Select (ADCTSSEL)** register to specify in which PWM module the generator is located. The default register reset selects PWM module 0 for all generators.
4. For each sample in the sample sequence, configure the corresponding input source in the **ADCSSMUX_n** and **ADCSEMUX_n** registers.
5. For each sample in the sample sequence, configure the sample control bits in the corresponding nibble in the **ADCSSCTL_n** register. When programming the last nibble, ensure that the `END` bit is set. Failure to set the `END` bit causes unpredictable behavior.
6. If interrupts are to be used, set the corresponding `MASK` bit in the **ADCIM** register.
7. Enable the sample sequencer logic by setting the corresponding `ASENn` bit in the **ADCACTSS** register.

18.5 Register Map

Table 18-7 on page 1197 lists the ADC registers. The offset listed is a hexadecimal increment to the register's address, relative to that ADC module's base address of:

- ADC0: 0x4003.8000
- ADC1: 0x4003.9000

Note that the ADC module clock must be enabled before the registers can be programmed (see page 403). There must be a delay of 3 system clocks after the ADC module clock is enabled before any ADC module registers are accessed.

Table 18-7. ADC Register Map

Offset	Name	Type	Reset	Description	See page
0x000	ADCACTSS	RW	0x0000.0000	ADC Active Sample Sequencer	1201
0x004	ADCRIS	RO	0x0000.0000	ADC Raw Interrupt Status	1203
0x008	ADCIM	RW	0x0000.0000	ADC Interrupt Mask	1206
0x00C	ADCISC	RW1C	0x0000.0000	ADC Interrupt Status and Clear	1209
0x010	ADCOSTAT	RW1C	0x0000.0000	ADC Overflow Status	1213
0x014	ADCEMUX	RW	0x0000.0000	ADC Event Multiplexer Select	1215

Table 18-7. ADC Register Map (continued)

Offset	Name	Type	Reset	Description	See page
0x018	ADCUSTAT	RW1C	0x0000.0000	ADC Underflow Status	1220
0x01C	ADCTSSEL	RW	0x0000.0000	ADC Trigger Source Select	1221
0x020	ADCSSPRI	RW	0x0000.3210	ADC Sample Sequencer Priority	1223
0x024	ADCSPC	RW	0x0000.0000	ADC Sample Phase Control	1225
0x028	ADCPSSI	RW	-	ADC Processor Sample Sequence Initiate	1227
0x030	ADCSAC	RW	0x0000.0000	ADC Sample Averaging Control	1229
0x034	ADCDCISC	RW1C	0x0000.0000	ADC Digital Comparator Interrupt Status and Clear	1230
0x038	ADCCTL	RW	0x0000.0000	ADC Control	1232
0x040	ADCSSMUX0	RW	0x0000.0000	ADC Sample Sequence Input Multiplexer Select 0	1233
0x044	ADCSSCTL0	RW	0x0000.0000	ADC Sample Sequence Control 0	1235
0x048	ADCSSFIFO0	RO	-	ADC Sample Sequence Result FIFO 0	1242
0x04C	ADCSSFSTAT0	RO	0x0000.0100	ADC Sample Sequence FIFO 0 Status	1243
0x050	ADCSSOP0	RW	0x0000.0000	ADC Sample Sequence 0 Operation	1245
0x054	ADCSSDC0	RW	0x0000.0000	ADC Sample Sequence 0 Digital Comparator Select	1247
0x058	ADCSSEMUX0	RW	0x0000.0000	ADC Sample Sequence Extended Input Multiplexer Select 0	1249
0x05C	ADCSSSTSH0	RW	0x0000.0000	ADC Sample Sequence 0 Sample and Hold Time	1251
0x060	ADCSSMUX1	RW	0x0000.0000	ADC Sample Sequence Input Multiplexer Select 1	1253
0x064	ADCSSCTL1	RW	0x0000.0000	ADC Sample Sequence Control 1	1254
0x068	ADCSSFIFO1	RO	-	ADC Sample Sequence Result FIFO 1	1242
0x06C	ADCSSFSTAT1	RO	0x0000.0100	ADC Sample Sequence FIFO 1 Status	1243
0x070	ADCSSOP1	RW	0x0000.0000	ADC Sample Sequence 1 Operation	1258
0x074	ADCSSDC1	RW	0x0000.0000	ADC Sample Sequence 1 Digital Comparator Select	1259
0x078	ADCSSEMUX1	RW	0x0000.0000	ADC Sample Sequence Extended Input Multiplexer Select 1	1261
0x07C	ADCSSSTSH1	RW	0x0000.0000	ADC Sample Sequence 1 Sample and Hold Time	1263
0x080	ADCSSMUX2	RW	0x0000.0000	ADC Sample Sequence Input Multiplexer Select 2	1253
0x084	ADCSSCTL2	RW	0x0000.0000	ADC Sample Sequence Control 2	1254
0x088	ADCSSFIFO2	RO	-	ADC Sample Sequence Result FIFO 2	1242
0x08C	ADCSSFSTAT2	RO	0x0000.0100	ADC Sample Sequence FIFO 2 Status	1243
0x090	ADCSSOP2	RW	0x0000.0000	ADC Sample Sequence 2 Operation	1258
0x094	ADCSSDC2	RW	0x0000.0000	ADC Sample Sequence 2 Digital Comparator Select	1259

Table 18-7. ADC Register Map (continued)

Offset	Name	Type	Reset	Description	See page
0x098	ADCSSEMUX2	RW	0x0000.0000	ADC Sample Sequence Extended Input Multiplexer Select 2	1261
0x09C	ADCSSTSH2	RW	0x0000.0000	ADC Sample Sequence 2 Sample and Hold Time	1263
0x0A0	ADCSSMUX3	RW	0x0000.0000	ADC Sample Sequence Input Multiplexer Select 3	1265
0x0A4	ADCSSCTL3	RW	0x0000.0000	ADC Sample Sequence Control 3	1266
0x0A8	ADCSSFIFO3	RO	-	ADC Sample Sequence Result FIFO 3	1242
0x0AC	ADCSSFSTAT3	RO	0x0000.0100	ADC Sample Sequence FIFO 3 Status	1243
0x0B0	ADCSSOP3	RW	0x0000.0000	ADC Sample Sequence 3 Operation	1268
0x0B4	ADCSSDC3	RW	0x0000.0000	ADC Sample Sequence 3 Digital Comparator Select	1269
0x0B8	ADCSSEMUX3	RW	0x0000.0000	ADC Sample Sequence Extended Input Multiplexer Select 3	1270
0x0BC	ADCSSTSH3	RW	0x0000.0000	ADC Sample Sequence 3 Sample and Hold Time	1271
0xD00	ADCDCRIC	WO	0x0000.0000	ADC Digital Comparator Reset Initial Conditions	1272
0xE00	ADCDCCTL0	RW	0x0000.0000	ADC Digital Comparator Control 0	1277
0xE04	ADCDCCTL1	RW	0x0000.0000	ADC Digital Comparator Control 1	1277
0xE08	ADCDCCTL2	RW	0x0000.0000	ADC Digital Comparator Control 2	1277
0xE0C	ADCDCCTL3	RW	0x0000.0000	ADC Digital Comparator Control 3	1277
0xE10	ADCDCCTL4	RW	0x0000.0000	ADC Digital Comparator Control 4	1277
0xE14	ADCDCCTL5	RW	0x0000.0000	ADC Digital Comparator Control 5	1277
0xE18	ADCDCCTL6	RW	0x0000.0000	ADC Digital Comparator Control 6	1277
0xE1C	ADCDCCTL7	RW	0x0000.0000	ADC Digital Comparator Control 7	1277
0xE40	ADCDCCMP0	RW	0x0000.0000	ADC Digital Comparator Range 0	1280
0xE44	ADCDCCMP1	RW	0x0000.0000	ADC Digital Comparator Range 1	1280
0xE48	ADCDCCMP2	RW	0x0000.0000	ADC Digital Comparator Range 2	1280
0xE4C	ADCDCCMP3	RW	0x0000.0000	ADC Digital Comparator Range 3	1280
0xE50	ADCDCCMP4	RW	0x0000.0000	ADC Digital Comparator Range 4	1280
0xE54	ADCDCCMP5	RW	0x0000.0000	ADC Digital Comparator Range 5	1280
0xE58	ADCDCCMP6	RW	0x0000.0000	ADC Digital Comparator Range 6	1280
0xE5C	ADCDCCMP7	RW	0x0000.0000	ADC Digital Comparator Range 7	1280
0xFC0	ADCPP	RO	0x01B0.2147	ADC Peripheral Properties	1281
0xFC4	ADCPC	RW	0x0000.0007	ADC Peripheral Configuration	1283
0xFC8	ADCCC	RW	0x0000.0001	ADC Clock Configuration	1284

18.6 Register Descriptions

The remainder of this section lists and describes the ADC registers, in numerical order by address offset.

Register 1: ADC Active Sample Sequencer (ADCACTSS), offset 0x000

This register controls the activation of the sample sequencers. Each sample sequencer can be enabled or disabled independently.

ADC Active Sample Sequencer (ADCACTSS)

ADC0 base: 0x4003.8000
 ADC1 base: 0x4003.9000
 Offset 0x000
 Type RW, reset 0x0000.0000

	31	30	29	28	27	26	25	24	23	22	21	20	19	18	17	16
	reserved															BUSY
Type	RO	RO	RO	RO	RO	RO	RO	RO	RO	RO	RO	RO	RO	RO	RO	RO
Reset	0	0	0	0	0	0	0	0	0	0	0	0	0	0	0	0
	15	14	13	12	11	10	9	8	7	6	5	4	3	2	1	0
	reserved				ADEN3	ADEN2	ADEN1	ADEN0	reserved				ASEN3	ASEN2	ASEN1	ASEN0
Type	RO	RO	RO	RO	RW	RW	RW	RW	RO	RO	RO	RO	RW	RW	RW	RW
Reset	0	0	0	0	0	0	0	0	0	0	0	0	0	0	0	0

Bit/Field	Name	Type	Reset	Description
31:17	reserved	RO	0	Software should not rely on the value of a reserved bit. To provide compatibility with future products, the value of a reserved bit should be preserved across a read-modify-write operation.
16	BUSY	RO	0	ADC Busy Value Description 0 ADC is idle 1 ADC is busy
15:12	reserved	RO	0	Software should not rely on the value of a reserved bit. To provide compatibility with future products, the value of a reserved bit should be preserved across a read-modify-write operation.
11	ADEN3	RW	0	ADC SS3 DMA Enable Value Description 0 DMA for Sample Sequencer 3 is disabled. 1 DMA for Sample Sequencer 3 is enabled.
10	ADEN2	RW	0	ADC SS2 DMA Enable Value Description 0 DMA for Sample Sequencer 2 is disabled. 1 DMA for Sample Sequencer 2 is enabled.

Note: In order to use the `BUSY` bit, the **ADC Event Multiplexer Select (ADCEMUX)** register must be programmed such that no trigger is selected (bit field encoding is 0xE). The NEVER encoding in the **ADCEMUX** register allows the ADC to safely be put in Deep-Sleep mode.

Bit/Field	Name	Type	Reset	Description
9	ADEN1	RW	0	ADC SS1 DMA Enable Value Description 0 DMA for Sample Sequencer 1 is disabled. 1 DMA for Sample Sequencer 1 is enabled.
8	ADEN0	RW	0	ADC SS1 DMA Enable Value Description 0 DMA for Sample Sequencer 1 is disabled. 1 DMA for Sample Sequencer 1 is enabled.
7:4	reserved	RO	0	Software should not rely on the value of a reserved bit. To provide compatibility with future products, the value of a reserved bit should be preserved across a read-modify-write operation.
3	ASEN3	RW	0	ADC SS3 Enable Value Description 0 Sample Sequencer 3 is disabled. 1 Sample Sequencer 3 is enabled.
2	ASEN2	RW	0	ADC SS2 Enable Value Description 0 Sample Sequencer 2 is disabled. 1 Sample Sequencer 2 is enabled.
1	ASEN1	RW	0	ADC SS1 Enable Value Description 0 Sample Sequencer 1 is disabled. 1 Sample Sequencer 1 is enabled.
0	ASEN0	RW	0	ADC SS0 Enable Value Description 0 Sample Sequencer 0 is disabled. 1 Sample Sequencer 0 is enabled.

Register 2: ADC Raw Interrupt Status (ADCRIS), offset 0x004

This register shows the status of the raw interrupt signal of each sample sequencer. These bits may be polled by software to look for interrupt conditions without sending the interrupts to the interrupt controller.

ADC Raw Interrupt Status (ADCRIS)

ADC0 base: 0x4003.8000
 ADC1 base: 0x4003.9000
 Offset 0x004
 Type RO, reset 0x0000.0000

	31	30	29	28	27	26	25	24	23	22	21	20	19	18	17	16
	reserved															INRDC
Type	RO	RO	RO	RO	RO	RO	RO	RO	RO	RO	RO	RO	RO	RO	RO	RO
Reset	0	0	0	0	0	0	0	0	0	0	0	0	0	0	0	0
	15	14	13	12	11	10	9	8	7	6	5	4	3	2	1	0
	reserved				DMAINR3	DMAINR2	DMAINR1	DMAINR0	reserved				INR3	INR2	INR1	INR0
Type	RO	RO	RO	RO	RO	RO	RO	RO	RO	RO	RO	RO	RO	RO	RO	RO
Reset	0	0	0	0	0	0	0	0	0	0	0	0	0	0	0	0

Bit/Field	Name	Type	Reset	Description
31:17	reserved	RO	0x000	Software should not rely on the value of a reserved bit. To provide compatibility with future products, the value of a reserved bit should be preserved across a read-modify-write operation.
16	INRDC	RO	0	Digital Comparator Raw Interrupt Status Value Description 0 All bits in the ADCDCISC register are clear. 1 At least one bit in the ADCDCISC register is set, meaning that a digital comparator interrupt has occurred.
15:12	reserved	RO	0	Software should not rely on the value of a reserved bit. To provide compatibility with future products, the value of a reserved bit should be preserved across a read-modify-write operation.
11	DMAINR3	RO	0	SS3 DMA Raw Interrupt Status Value Description 0 The DMA interrupt has not occurred. 1 The sample sequence 3 DMA interrupt is asserted. This bit is cleared by writing a 1 to the DMAINR3 bit in the ADCISC register.
10	DMAINR2	RO	0	SS2 DMA Raw Interrupt Status Value Description 0 The DMA interrupt has not occurred. 1 The sample sequence 2 DMA interrupt is asserted. This bit is cleared by writing a 1 to the DMAINR2 bit in the ADCISC register.

Bit/Field	Name	Type	Reset	Description
9	DMAINR1	RO	0	<p>SS1 DMA Raw Interrupt Status</p> <p>Value Description</p> <p>0 The DMA interrupt has not occurred.</p> <p>1 The sample sequence 1 DMA interrupt is asserted.</p> <p>This bit is cleared by writing a 1 to the DMAINR1 bit in the ADCISC register.</p>
8	DMAINR0	RO	0	<p>SS0 DMA Raw Interrupt Status</p> <p>Value Description</p> <p>0 The DMA interrupt has not occurred.</p> <p>1 The sample sequence 0 DMA interrupt is asserted.</p> <p>This bit is cleared by writing a 1 to the DMAINR0 bit in the ADCISC register.</p>
7:4	reserved	RO	0	<p>Software should not rely on the value of a reserved bit. To provide compatibility with future products, the value of a reserved bit should be preserved across a read-modify-write operation.</p>
3	INR3	RO	0	<p>SS3 Raw Interrupt Status</p> <p>Value Description</p> <p>0 An interrupt has not occurred.</p> <p>1 A sample has completed conversion and the respective ADCSSCTL3 IEn bit is set, enabling a raw interrupt.</p> <p>This bit is cleared by writing a 1 to the IN3 bit in the ADCISC register.</p>
2	INR2	RO	0	<p>SS2 Raw Interrupt Status</p> <p>Value Description</p> <p>0 An interrupt has not occurred.</p> <p>1 A sample has completed conversion and the respective ADCSSCTL2 IEn bit is set, enabling a raw interrupt.</p> <p>This bit is cleared by writing a 1 to the IN2 bit in the ADCISC register.</p>
1	INR1	RO	0	<p>SS1 Raw Interrupt Status</p> <p>Value Description</p> <p>0 An interrupt has not occurred.</p> <p>1 A sample has completed conversion and the respective ADCSSCTL1 IEn bit is set, enabling a raw interrupt.</p> <p>This bit is cleared by writing a 1 to the IN1 bit in the ADCISC register.</p>

Bit/Field	Name	Type	Reset	Description
0	INR0	RO	0	SS0 Raw Interrupt Status
				Value Description
				0 An interrupt has not occurred.
				1 A sample has completed conversion and the respective ADCSSCTL0 <i>IE_n</i> bit is set, enabling a raw interrupt.
				This bit is cleared by writing a 1 to the <i>IN0</i> bit in the ADCISC register.

Register 3: ADC Interrupt Mask (ADCIM), offset 0x008

This register controls whether the sample sequencer and digital comparator raw interrupt signals are sent to the interrupt controller. Each raw interrupt signal can be masked independently.

Note: For a 1 to 2 Msps rate, as the system clock frequency approaches the ADC clock frequency, it is recommended that the application use the μ DMA to store conversion data from the FIFO to memory before processing rather than an interrupt-driven single data read. Using the μ DMA to store multiple samples before interrupting the processor amortizes interrupt overhead across multiple transfers and prevents loss of sample data.

Note: Only a single $DCONSS_n$ bit should be set at any given time. Setting more than one of these bits results in the $INRDC$ bit from the **ADCRIS** register being masked, and no interrupt is generated on any of the sample sequencer interrupt lines. It is recommended that when interrupts are used, they are enabled on alternating samples or at the end of the sample sequence.

ADC Interrupt Mask (ADCIM)

ADC0 base: 0x4003.8000
 ADC1 base: 0x4003.9000
 Offset 0x008
 Type RW, reset 0x0000.0000

	31	30	29	28	27	26	25	24	23	22	21	20	19	18	17	16
	reserved												DCONSS3	DCONSS2	DCONSS1	DCONSS0
Type	RO	RO	RO	RO	RO	RO	RO	RO	RO	RO	RO	RO	RW	RW	RW	RW
Reset	0	0	0	0	0	0	0	0	0	0	0	0	0	0	0	0
	15	14	13	12	11	10	9	8	7	6	5	4	3	2	1	0
	reserved				DMAMASK3	DMAMASK2	DMAMASK1	DMAMASK0	reserved				MASK3	MASK2	MASK1	MASK0
Type	RO	RO	RO	RO	RW	RW	RW	RW	RO	RO	RO	RO	RW	RW	RW	RW
Reset	0	0	0	0	0	0	0	0	0	0	0	0	0	0	0	0

Bit/Field	Name	Type	Reset	Description
31:20	reserved	RO	0x000	Software should not rely on the value of a reserved bit. To provide compatibility with future products, the value of a reserved bit should be preserved across a read-modify-write operation.
19	DCONSS3	RW	0	Digital Comparator Interrupt on SS3 Value Description 0 The status of the digital comparators does not affect the SS3 interrupt status. 1 The raw interrupt signal from the digital comparators ($INRDC$ bit in the ADCRIS register) is sent to the interrupt controller on the SS3 interrupt line.
18	DCONSS2	RW	0	Digital Comparator Interrupt on SS2 Value Description 0 The status of the digital comparators does not affect the SS2 interrupt status. 1 The raw interrupt signal from the digital comparators ($INRDC$ bit in the ADCRIS register) is sent to the interrupt controller on the SS2 interrupt line.

Bit/Field	Name	Type	Reset	Description
17	DCONSS1	RW	0	Digital Comparator Interrupt on SS1 Value Description 0 The status of the digital comparators does not affect the SS1 interrupt status. 1 The raw interrupt signal from the digital comparators (<i>INRDC</i> bit in the ADCRIS register) is sent to the interrupt controller on the SS1 interrupt line.
16	DCONSS0	RW	0	Digital Comparator Interrupt on SS0 Value Description 0 The status of the digital comparators does not affect the SS0 interrupt status. 1 The raw interrupt signal from the digital comparators (<i>INRDC</i> bit in the ADCRIS register) is sent to the interrupt controller on the SS0 interrupt line.
15:12	reserved	RO	0	Software should not rely on the value of a reserved bit. To provide compatibility with future products, the value of a reserved bit should be preserved across a read-modify-write operation.
11	DMAMASK3	RW	0	SS3 DMA Interrupt Mask Value Description 0 The status of Sample Sequencer 3 DMA does not affect the SS3 interrupt status. 1 The raw interrupt signal from Sample Sequencer 3 DMA (ADCRIS register <i>DMAINR3</i> bit) is sent to the interrupt controller.
10	DMAMASK2	RW	0	SS2 DMA Interrupt Mask Value Description 0 The status of Sample Sequencer 2 DMA does not affect the SS2 interrupt status. 1 The raw interrupt signal from Sample Sequencer 2 DMA (ADCRIS register <i>DMAINR2</i> bit) is sent to the interrupt controller.
9	DMAMASK1	RW	0	SS1 DMA Interrupt Mask Value Description 0 The status of Sample Sequencer 1 DMA does not affect the SS1 interrupt status. 1 The raw interrupt signal from Sample Sequencer 1 DMA (ADCRIS register <i>DMAINR1</i> bit) is sent to the interrupt controller.

Bit/Field	Name	Type	Reset	Description
8	DMAMASK0	RW	0	SS0 DMA Interrupt Mask Value Description 0 The status of Sample Sequencer 0 DMA does not affect the SS0 interrupt status. 1 The raw interrupt signal from Sample Sequencer 0 DMA (ADCRIS register <code>DMAINR0</code> bit) is sent to the interrupt controller.
7:4	reserved	RO	0	Software should not rely on the value of a reserved bit. To provide compatibility with future products, the value of a reserved bit should be preserved across a read-modify-write operation.
3	MASK3	RW	0	SS3 Interrupt Mask Value Description 0 The status of Sample Sequencer 3 does not affect the SS3 interrupt status. 1 The raw interrupt signal from Sample Sequencer 3 (ADCRIS register <code>INR3</code> bit) is sent to the interrupt controller.
2	MASK2	RW	0	SS2 Interrupt Mask Value Description 0 The status of Sample Sequencer 2 does not affect the SS2 interrupt status. 1 The raw interrupt signal from Sample Sequencer 2 (ADCRIS register <code>INR2</code> bit) is sent to the interrupt controller.
1	MASK1	RW	0	SS1 Interrupt Mask Value Description 0 The status of Sample Sequencer 1 does not affect the SS1 interrupt status. 1 The raw interrupt signal from Sample Sequencer 1 (ADCRIS register <code>INR1</code> bit) is sent to the interrupt controller.
0	MASK0	RW	0	SS0 Interrupt Mask Value Description 0 The status of Sample Sequencer 0 does not affect the SS0 interrupt status. 1 The raw interrupt signal from Sample Sequencer 0 (ADCRIS register <code>INR0</code> bit) is sent to the interrupt controller.

Register 4: ADC Interrupt Status and Clear (ADCISC), offset 0x00C

This register provides the mechanism for clearing sample sequencer interrupt conditions and shows the status of interrupts generated by the sample sequencers and the digital comparators which have been sent to the interrupt controller. When read, each bit field is the logical AND of the respective **INR** and **MASK** bits. Sample sequencer interrupts are cleared by writing a 1 to the corresponding bit position. Digital comparator interrupts are cleared by writing a 1 to the appropriate bits in the **ADCDCISC** register. If software is polling the **ADCRIS** instead of generating interrupts, the sample sequence **INR_n** bits are still cleared via the **ADCISC** register, even if the **IN_n** bit is not set.

ADC Interrupt Status and Clear (ADCISC)

ADC0 base: 0x4003.8000
 ADC1 base: 0x4003.9000
 Offset 0x00C
 Type RW1C, reset 0x0000.0000

	31	30	29	28	27	26	25	24	23	22	21	20	19	18	17	16
	reserved												DCINSS3	DCINSS2	DCINSS1	DCINSS0
Type	RO	RO	RO	RO	RO	RO	RO	RO	RO	RO	RO	RO	RO	RO	RO	RO
Reset	0	0	0	0	0	0	0	0	0	0	0	0	0	0	0	0
	15	14	13	12	11	10	9	8	7	6	5	4	3	2	1	0
	reserved				DMAIN3	DMAIN2	DMAIN1	DMAIN0	reserved				IN3	IN2	IN1	IN0
Type	RO	RO	RO	RO	RW1C	RW1C	RW1C	RW1C	RO	RO	RO	RO	RW1C	RW1C	RW1C	RW1C
Reset	0	0	0	0	0	0	0	0	0	0	0	0	0	0	0	0

Bit/Field	Name	Type	Reset	Description
31:20	reserved	RO	0x000	Software should not rely on the value of a reserved bit. To provide compatibility with future products, the value of a reserved bit should be preserved across a read-modify-write operation.
19	DCINSS3	RO	0	Digital Comparator Interrupt Status on SS3 Value Description 0 No interrupt has occurred or the interrupt is masked. 1 Both the INRDC bit in the ADCRIS register and the DCONSS3 bit in the ADCIM register are set, providing a level-based interrupt to the interrupt controller. This bit is cleared by writing a 1 to it. Clearing this bit also clears the INRDC bit in the ADCRIS register.
18	DCINSS2	RO	0	Digital Comparator Interrupt Status on SS2 Value Description 0 No interrupt has occurred or the interrupt is masked. 1 Both the INRDC bit in the ADCRIS register and the DCONSS2 bit in the ADCIM register are set, providing a level-based interrupt to the interrupt controller. This bit is cleared by writing a 1 to it. Clearing this bit also clears the INRDC bit in the ADCRIS register.

Bit/Field	Name	Type	Reset	Description
17	DCINSS1	RO	0	<p>Digital Comparator Interrupt Status on SS1</p> <p>Value Description</p> <p>0 No interrupt has occurred or the interrupt is masked.</p> <p>1 Both the <code>INRDC</code> bit in the ADCRIS register and the <code>DCONSS1</code> bit in the ADCIM register are set, providing a level-based interrupt to the interrupt controller.</p> <p>This bit is cleared by writing a 1 to it. Clearing this bit also clears the <code>INRDC</code> bit in the ADCRIS register.</p>
16	DCINSS0	RO	0	<p>Digital Comparator Interrupt Status on SS0</p> <p>Value Description</p> <p>0 No interrupt has occurred or the interrupt is masked.</p> <p>1 Both the <code>INRDC</code> bit in the ADCRIS register and the <code>DCONSS0</code> bit in the ADCIM register are set, providing a level-based interrupt to the interrupt controller.</p> <p>This bit is cleared by writing a 1 to it. Clearing this bit also clears the <code>INRDC</code> bit in the ADCRIS register.</p>
15:12	reserved	RO	0	<p>Software should not rely on the value of a reserved bit. To provide compatibility with future products, the value of a reserved bit should be preserved across a read-modify-write operation.</p>
11	DMAIN3	RW1C	0	<p>SS3 DMA Interrupt Status and Clear</p> <p>Value Description</p> <p>0 No interrupt has occurred or the interrupt is masked.</p> <p>1 Both the <code>DMAINR3</code> bit in the ADCRIS register and the <code>DMAMASK3</code> bit in the ADCIM register are set, providing a level-based interrupt to the interrupt controller.</p> <p>This bit is cleared by writing a 1. Clearing this bit also clears the <code>DMAINR3</code> bit in the ADCRIS register.</p>
10	DMAIN2	RW1C	0	<p>SS2 DMA Interrupt Status and Clear</p> <p>Value Description</p> <p>0 No interrupt has occurred or the interrupt is masked.</p> <p>1 Both the <code>DMAINR2</code> bit in the ADCRIS register and the <code>DMAMASK2</code> bit in the ADCIM register are set, providing a level-based interrupt to the interrupt controller.</p> <p>This bit is cleared by writing a 1. Clearing this bit also clears the <code>DMAINR2</code> bit in the ADCRIS register.</p>

Bit/Field	Name	Type	Reset	Description
9	DMAIN1	RW1C	0	<p>SS1 DMA Interrupt Status and Clear</p> <p>Value Description</p> <p>0 No interrupt has occurred or the interrupt is masked.</p> <p>1 Both the <code>DMA_INR1</code> bit in the ADCRIS register and the <code>DMAMASK1</code> bit in the ADCIM register are set, providing a level-based interrupt to the interrupt controller.</p> <p>This bit is cleared by writing a 1. Clearing this bit also clears the <code>DMA_INR1</code> bit in the ADCRIS register.</p>
8	DMAIN0	RW1C	0	<p>SS0 DMA Interrupt Status and Clear</p> <p>Value Description</p> <p>0 No interrupt has occurred or the interrupt is masked.</p> <p>1 Both the <code>DMA_INR0</code> bit in the ADCRIS register and the <code>DMAMASK0</code> bit in the ADCIM register are set, providing a level-based interrupt to the interrupt controller.</p> <p>This bit is cleared by writing a 1. Clearing this bit also clears the <code>DMA_INR0</code> bit in the ADCRIS register.</p>
7:4	reserved	RO	0	Software should not rely on the value of a reserved bit. To provide compatibility with future products, the value of a reserved bit should be preserved across a read-modify-write operation.
3	IN3	RW1C	0	<p>SS3 Interrupt Status and Clear</p> <p>Value Description</p> <p>0 No interrupt has occurred or the interrupt is masked.</p> <p>1 Both the <code>INR3</code> bit in the ADCRIS register and the <code>MASK3</code> bit in the ADCIM register are set, providing a level-based interrupt to the interrupt controller.</p> <p>This bit is cleared by writing a 1. Clearing this bit also clears the <code>INR3</code> bit in the ADCRIS register.</p>
2	IN2	RW1C	0	<p>SS2 Interrupt Status and Clear</p> <p>Value Description</p> <p>0 No interrupt has occurred or the interrupt is masked.</p> <p>1 Both the <code>INR2</code> bit in the ADCRIS register and the <code>MASK2</code> bit in the ADCIM register are set, providing a level-based interrupt to the interrupt controller.</p> <p>This bit is cleared by writing a 1. Clearing this bit also clears the <code>INR2</code> bit in the ADCRIS register.</p>

Bit/Field	Name	Type	Reset	Description
1	IN1	RW1C	0	<p>SS1 Interrupt Status and Clear</p> <p>Value Description</p> <p>0 No interrupt has occurred or the interrupt is masked.</p> <p>1 Both the <code>INR1</code> bit in the ADCRIS register and the <code>MASK1</code> bit in the ADCIM register are set, providing a level-based interrupt to the interrupt controller.</p> <p>This bit is cleared by writing a 1. Clearing this bit also clears the <code>INR1</code> bit in the ADCRIS register.</p>
0	IN0	RW1C	0	<p>SS0 Interrupt Status and Clear</p> <p>Value Description</p> <p>0 No interrupt has occurred or the interrupt is masked.</p> <p>1 Both the <code>INR0</code> bit in the ADCRIS register and the <code>MASK0</code> bit in the ADCIM register are set, providing a level-based interrupt to the interrupt controller.</p> <p>This bit is cleared by writing a 1. Clearing this bit also clears the <code>INR0</code> bit in the ADCRIS register.</p>

Register 5: ADC Overflow Status (ADCOSTAT), offset 0x010

This register indicates overflow conditions in the sample sequencer FIFOs. Once the overflow condition has been handled by software, the condition can be cleared by writing a 1 to the corresponding bit position.

ADC Overflow Status (ADCOSTAT)

ADC0 base: 0x4003.8000
 ADC1 base: 0x4003.9000
 Offset 0x010
 Type RW1C, reset 0x0000.0000

	31	30	29	28	27	26	25	24	23	22	21	20	19	18	17	16	
	reserved																
Type	RO	RO	RO	RO	RO	RO	RO	RO	RO	RO	RO	RO	RO	RO	RO	RO	
Reset	0	0	0	0	0	0	0	0	0	0	0	0	0	0	0	0	
	15	14	13	12	11	10	9	8	7	6	5	4	3	2	1	0	
	reserved												OV3	OV2	OV1	OV0	
Type	RO	RO	RO	RO	RO	RO	RO	RO	RO	RO	RO	RO	RO	RW1C	RW1C	RW1C	RW1C
Reset	0	0	0	0	0	0	0	0	0	0	0	0	0	0	0	0	0

Bit/Field	Name	Type	Reset	Description
31:4	reserved	RO	0x0000.000	Software should not rely on the value of a reserved bit. To provide compatibility with future products, the value of a reserved bit should be preserved across a read-modify-write operation.
3	OV3	RW1C	0	SS3 FIFO Overflow Value Description 0 The FIFO has not overflowed. 1 The FIFO for Sample Sequencer 3 has hit an overflow condition, meaning that the FIFO is full and a write was requested. When an overflow is detected, the most recent write is dropped. This bit is cleared by writing a 1.
2	OV2	RW1C	0	SS2 FIFO Overflow Value Description 0 The FIFO has not overflowed. 1 The FIFO for Sample Sequencer 2 has hit an overflow condition, meaning that the FIFO is full and a write was requested. When an overflow is detected, the most recent write is dropped. This bit is cleared by writing a 1.
1	OV1	RW1C	0	SS1 FIFO Overflow Value Description 0 The FIFO has not overflowed. 1 The FIFO for Sample Sequencer 1 has hit an overflow condition, meaning that the FIFO is full and a write was requested. When an overflow is detected, the most recent write is dropped. This bit is cleared by writing a 1.

Bit/Field	Name	Type	Reset	Description
0	OV0	RW1C	0	SS0 FIFO Overflow
				Value Description
				0 The FIFO has not overflowed.
				1 The FIFO for Sample Sequencer 0 has hit an overflow condition, meaning that the FIFO is full and a write was requested. When an overflow is detected, the most recent write is dropped.
				This bit is cleared by writing a 1.

Register 6: ADC Event Multiplexer Select (ADCEMUX), offset 0x014

The **ADCEMUX** selects the event (trigger) that initiates sampling for each sample sequencer. Each sample sequencer can be configured with a unique trigger source.

ADC Event Multiplexer Select (ADCEMUX)

ADC0 base: 0x4003.8000

ADC1 base: 0x4003.9000

Offset 0x014

Type RW, reset 0x0000.0000

	31	30	29	28	27	26	25	24	23	22	21	20	19	18	17	16
	reserved															
Type	RO	RO	RO	RO	RO	RO	RO	RO	RO	RO	RO	RO	RO	RO	RO	RO
Reset	0	0	0	0	0	0	0	0	0	0	0	0	0	0	0	0
	15	14	13	12	11	10	9	8	7	6	5	4	3	2	1	0
	EM3				EM2				EM1				EM0			
Type	RW	RW	RW	RW	RW	RW	RW	RW	RW	RW	RW	RW	RW	RW	RW	RW
Reset	0	0	0	0	0	0	0	0	0	0	0	0	0	0	0	0

Bit/Field	Name	Type	Reset	Description
31:16	reserved	RO	0x0000	Software should not rely on the value of a reserved bit. To provide compatibility with future products, the value of a reserved bit should be preserved across a read-modify-write operation.

Bit/Field	Name	Type	Reset	Description																																					
15:12	EM3	RW	0x0	<p>SS3 Trigger Select</p> <p>This field selects the trigger source for Sample Sequencer 3.</p> <p>The valid configurations for this field are:</p> <table border="1"> <thead> <tr> <th>Value</th> <th>Event</th> </tr> </thead> <tbody> <tr> <td>0x0</td> <td> <p>Processor (default)</p> <p>The trigger is initiated by setting the SS_n bit in the ADCPSSI register.</p> </td> </tr> <tr> <td>0x1</td> <td> <p>Analog Comparator 0</p> <p>This trigger is configured by the Analog Comparator Control 0 (ACCTL0) register (page 1789).</p> </td> </tr> <tr> <td>0x2</td> <td> <p>Analog Comparator 1</p> <p>This trigger is configured by the Analog Comparator Control 1 (ACCTL1) register (page 1789).</p> </td> </tr> <tr> <td>0x3</td> <td> <p>Analog Comparator 2</p> <p>This trigger is configured by the Analog Comparator Control 2 (ACCTL2) register (page 1789).</p> </td> </tr> <tr> <td>0x4</td> <td> <p>External (GPIO Pins)</p> <p>This trigger is connected to the GPIO interrupt for the corresponding GPIO (see “ADC Trigger Source” on page 758).</p> </td> </tr> <tr> <td>0x5</td> <td> <p>Timer</p> <p>In addition, the trigger must be enabled with the $TnOTE$ bit in the GPTMCTL register (page 1110).</p> </td> </tr> <tr> <td>0x6</td> <td> <p>PWM generator 0</p> <p>The PWM generator 0 trigger can be configured with the PWM0 Interrupt and Trigger Enable (PWM0INTEN) register (page 1837).</p> </td> </tr> <tr> <td>0x7</td> <td> <p>PWM generator 1</p> <p>The PWM generator 1 trigger can be configured with the PWM1INTEN register (page 1837).</p> </td> </tr> <tr> <td>0x8</td> <td> <p>PWM generator 2</p> <p>The PWM generator 2 trigger can be configured with the PWM2INTEN register (page 1837).</p> </td> </tr> <tr> <td>0x9</td> <td> <p>PWM generator 3</p> <p>The PWM generator 3 trigger can be configured with the PWM3INTEN register (page 1837).</p> </td> </tr> <tr> <td>0xA-0xD</td> <td>reserved</td> <td></td> <td></td> <td></td> </tr> <tr> <td>0xE</td> <td>Never Trigger (No triggers are allowed to the ADC digital interface)</td> <td></td> <td></td> <td></td> </tr> <tr> <td>0xF</td> <td>Always (continuously sample)</td> <td></td> <td></td> <td></td> </tr> </tbody> </table>	Value	Event	0x0	<p>Processor (default)</p> <p>The trigger is initiated by setting the SS_n bit in the ADCPSSI register.</p>	0x1	<p>Analog Comparator 0</p> <p>This trigger is configured by the Analog Comparator Control 0 (ACCTL0) register (page 1789).</p>	0x2	<p>Analog Comparator 1</p> <p>This trigger is configured by the Analog Comparator Control 1 (ACCTL1) register (page 1789).</p>	0x3	<p>Analog Comparator 2</p> <p>This trigger is configured by the Analog Comparator Control 2 (ACCTL2) register (page 1789).</p>	0x4	<p>External (GPIO Pins)</p> <p>This trigger is connected to the GPIO interrupt for the corresponding GPIO (see “ADC Trigger Source” on page 758).</p>	0x5	<p>Timer</p> <p>In addition, the trigger must be enabled with the $TnOTE$ bit in the GPTMCTL register (page 1110).</p>	0x6	<p>PWM generator 0</p> <p>The PWM generator 0 trigger can be configured with the PWM0 Interrupt and Trigger Enable (PWM0INTEN) register (page 1837).</p>	0x7	<p>PWM generator 1</p> <p>The PWM generator 1 trigger can be configured with the PWM1INTEN register (page 1837).</p>	0x8	<p>PWM generator 2</p> <p>The PWM generator 2 trigger can be configured with the PWM2INTEN register (page 1837).</p>	0x9	<p>PWM generator 3</p> <p>The PWM generator 3 trigger can be configured with the PWM3INTEN register (page 1837).</p>	0xA-0xD	reserved				0xE	Never Trigger (No triggers are allowed to the ADC digital interface)				0xF	Always (continuously sample)			
Value	Event																																								
0x0	<p>Processor (default)</p> <p>The trigger is initiated by setting the SS_n bit in the ADCPSSI register.</p>																																								
0x1	<p>Analog Comparator 0</p> <p>This trigger is configured by the Analog Comparator Control 0 (ACCTL0) register (page 1789).</p>																																								
0x2	<p>Analog Comparator 1</p> <p>This trigger is configured by the Analog Comparator Control 1 (ACCTL1) register (page 1789).</p>																																								
0x3	<p>Analog Comparator 2</p> <p>This trigger is configured by the Analog Comparator Control 2 (ACCTL2) register (page 1789).</p>																																								
0x4	<p>External (GPIO Pins)</p> <p>This trigger is connected to the GPIO interrupt for the corresponding GPIO (see “ADC Trigger Source” on page 758).</p>																																								
0x5	<p>Timer</p> <p>In addition, the trigger must be enabled with the $TnOTE$ bit in the GPTMCTL register (page 1110).</p>																																								
0x6	<p>PWM generator 0</p> <p>The PWM generator 0 trigger can be configured with the PWM0 Interrupt and Trigger Enable (PWM0INTEN) register (page 1837).</p>																																								
0x7	<p>PWM generator 1</p> <p>The PWM generator 1 trigger can be configured with the PWM1INTEN register (page 1837).</p>																																								
0x8	<p>PWM generator 2</p> <p>The PWM generator 2 trigger can be configured with the PWM2INTEN register (page 1837).</p>																																								
0x9	<p>PWM generator 3</p> <p>The PWM generator 3 trigger can be configured with the PWM3INTEN register (page 1837).</p>																																								
0xA-0xD	reserved																																								
0xE	Never Trigger (No triggers are allowed to the ADC digital interface)																																								
0xF	Always (continuously sample)																																								

Bit/Field	Name	Type	Reset	Description																																					
11:8	EM2	RW	0x0	<p>SS2 Trigger Select</p> <p>This field selects the trigger source for Sample Sequencer 2.</p> <p>The valid configurations for this field are:</p> <table border="1"> <thead> <tr> <th>Value</th> <th>Event</th> </tr> </thead> <tbody> <tr> <td>0x0</td> <td> <p>Processor (default)</p> <p>The trigger is initiated by setting the SS_n bit in the ADCPSSI register.</p> </td> </tr> <tr> <td>0x1</td> <td> <p>Analog Comparator 0</p> <p>This trigger is configured by the Analog Comparator Control 0 (ACCTL0) register (page 1789).</p> </td> </tr> <tr> <td>0x2</td> <td> <p>Analog Comparator 1</p> <p>This trigger is configured by the Analog Comparator Control 1 (ACCTL1) register (page 1789).</p> </td> </tr> <tr> <td>0x3</td> <td> <p>Analog Comparator 2</p> <p>This trigger is configured by the Analog Comparator Control 2 (ACCTL2) register (page 1789).</p> </td> </tr> <tr> <td>0x4</td> <td> <p>External (GPIO Pins)</p> <p>This trigger is connected to the GPIO interrupt for the corresponding GPIO (see "ADC Trigger Source" on page 758).</p> </td> </tr> <tr> <td>0x5</td> <td> <p>Timer</p> <p>In addition, the trigger must be enabled with the $TnOTE$ bit in the GPTMCTL register (page 1110).</p> </td> </tr> <tr> <td>0x6</td> <td> <p>PWM generator 0</p> <p>The PWM generator 0 trigger can be configured with the PWM0 Interrupt and Trigger Enable (PWM0INTEN) register (page 1837).</p> </td> </tr> <tr> <td>0x7</td> <td> <p>PWM generator 1</p> <p>The PWM generator 1 trigger can be configured with the PWM1INTEN register (page 1837).</p> </td> </tr> <tr> <td>0x8</td> <td> <p>PWM generator 2</p> <p>The PWM generator 2 trigger can be configured with the PWM2INTEN register (page 1837).</p> </td> </tr> <tr> <td>0x9</td> <td> <p>PWM generator 3</p> <p>The PWM generator 3 trigger can be configured with the PWM3INTEN register (page 1837).</p> </td> </tr> <tr> <td>0xA-0xD</td> <td>reserved</td> <td></td> <td></td> <td></td> </tr> <tr> <td>0xE</td> <td>Never Trigger (No triggers are allowed to the ADC digital interface)</td> <td></td> <td></td> <td></td> </tr> <tr> <td>0xF</td> <td>Always (continuously sample)</td> <td></td> <td></td> <td></td> </tr> </tbody> </table>	Value	Event	0x0	<p>Processor (default)</p> <p>The trigger is initiated by setting the SS_n bit in the ADCPSSI register.</p>	0x1	<p>Analog Comparator 0</p> <p>This trigger is configured by the Analog Comparator Control 0 (ACCTL0) register (page 1789).</p>	0x2	<p>Analog Comparator 1</p> <p>This trigger is configured by the Analog Comparator Control 1 (ACCTL1) register (page 1789).</p>	0x3	<p>Analog Comparator 2</p> <p>This trigger is configured by the Analog Comparator Control 2 (ACCTL2) register (page 1789).</p>	0x4	<p>External (GPIO Pins)</p> <p>This trigger is connected to the GPIO interrupt for the corresponding GPIO (see "ADC Trigger Source" on page 758).</p>	0x5	<p>Timer</p> <p>In addition, the trigger must be enabled with the $TnOTE$ bit in the GPTMCTL register (page 1110).</p>	0x6	<p>PWM generator 0</p> <p>The PWM generator 0 trigger can be configured with the PWM0 Interrupt and Trigger Enable (PWM0INTEN) register (page 1837).</p>	0x7	<p>PWM generator 1</p> <p>The PWM generator 1 trigger can be configured with the PWM1INTEN register (page 1837).</p>	0x8	<p>PWM generator 2</p> <p>The PWM generator 2 trigger can be configured with the PWM2INTEN register (page 1837).</p>	0x9	<p>PWM generator 3</p> <p>The PWM generator 3 trigger can be configured with the PWM3INTEN register (page 1837).</p>	0xA-0xD	reserved				0xE	Never Trigger (No triggers are allowed to the ADC digital interface)				0xF	Always (continuously sample)			
Value	Event																																								
0x0	<p>Processor (default)</p> <p>The trigger is initiated by setting the SS_n bit in the ADCPSSI register.</p>																																								
0x1	<p>Analog Comparator 0</p> <p>This trigger is configured by the Analog Comparator Control 0 (ACCTL0) register (page 1789).</p>																																								
0x2	<p>Analog Comparator 1</p> <p>This trigger is configured by the Analog Comparator Control 1 (ACCTL1) register (page 1789).</p>																																								
0x3	<p>Analog Comparator 2</p> <p>This trigger is configured by the Analog Comparator Control 2 (ACCTL2) register (page 1789).</p>																																								
0x4	<p>External (GPIO Pins)</p> <p>This trigger is connected to the GPIO interrupt for the corresponding GPIO (see "ADC Trigger Source" on page 758).</p>																																								
0x5	<p>Timer</p> <p>In addition, the trigger must be enabled with the $TnOTE$ bit in the GPTMCTL register (page 1110).</p>																																								
0x6	<p>PWM generator 0</p> <p>The PWM generator 0 trigger can be configured with the PWM0 Interrupt and Trigger Enable (PWM0INTEN) register (page 1837).</p>																																								
0x7	<p>PWM generator 1</p> <p>The PWM generator 1 trigger can be configured with the PWM1INTEN register (page 1837).</p>																																								
0x8	<p>PWM generator 2</p> <p>The PWM generator 2 trigger can be configured with the PWM2INTEN register (page 1837).</p>																																								
0x9	<p>PWM generator 3</p> <p>The PWM generator 3 trigger can be configured with the PWM3INTEN register (page 1837).</p>																																								
0xA-0xD	reserved																																								
0xE	Never Trigger (No triggers are allowed to the ADC digital interface)																																								
0xF	Always (continuously sample)																																								

Bit/Field	Name	Type	Reset	Description																																					
7:4	EM1	RW	0x0	<p>SS1 Trigger Select</p> <p>This field selects the trigger source for Sample Sequencer 1. The valid configurations for this field are:</p> <table border="1"> <thead> <tr> <th>Value</th> <th>Event</th> </tr> </thead> <tbody> <tr> <td>0x0</td> <td> <p>Processor (default)</p> <p>The trigger is initiated by setting the SS_n bit in the ADCPSSI register.</p> </td> </tr> <tr> <td>0x1</td> <td> <p>Analog Comparator 0</p> <p>This trigger is configured by the Analog Comparator Control 0 (ACCTL0) register (page 1789).</p> </td> </tr> <tr> <td>0x2</td> <td> <p>Analog Comparator 1</p> <p>This trigger is configured by the Analog Comparator Control 1 (ACCTL1) register (page 1789).</p> </td> </tr> <tr> <td>0x3</td> <td> <p>Analog Comparator 2</p> <p>This trigger is configured by the Analog Comparator Control 2 (ACCTL2) register (page 1789).</p> </td> </tr> <tr> <td>0x4</td> <td> <p>External (GPIO Pins)</p> <p>This trigger is connected to the GPIO interrupt for the corresponding GPIO (see “ADC Trigger Source” on page 758).</p> </td> </tr> <tr> <td>0x5</td> <td> <p>Timer</p> <p>In addition, the trigger must be enabled with the $TnOTE$ bit in the GPTMCTL register (page 1110).</p> </td> </tr> <tr> <td>0x6</td> <td> <p>PWM generator 0</p> <p>The PWM generator 0 trigger can be configured with the PWM0 Interrupt and Trigger Enable (PWM0INTEN) register (page 1837).</p> </td> </tr> <tr> <td>0x7</td> <td> <p>PWM generator 1</p> <p>The PWM generator 1 trigger can be configured with the PWM1INTEN register (page 1837).</p> </td> </tr> <tr> <td>0x8</td> <td> <p>PWM generator 2</p> <p>The PWM generator 2 trigger can be configured with the PWM2INTEN register (page 1837).</p> </td> </tr> <tr> <td>0x9</td> <td> <p>PWM generator 3</p> <p>The PWM generator 3 trigger can be configured with the PWM3INTEN register (page 1837).</p> </td> </tr> <tr> <td>0xA-0xD</td> <td>reserved</td> <td></td> <td></td> <td></td> </tr> <tr> <td>0xE</td> <td>Never Trigger (No triggers are allowed to the ADC digital interface)</td> <td></td> <td></td> <td></td> </tr> <tr> <td>0xF</td> <td>Always (continuously sample)</td> <td></td> <td></td> <td></td> </tr> </tbody> </table>	Value	Event	0x0	<p>Processor (default)</p> <p>The trigger is initiated by setting the SS_n bit in the ADCPSSI register.</p>	0x1	<p>Analog Comparator 0</p> <p>This trigger is configured by the Analog Comparator Control 0 (ACCTL0) register (page 1789).</p>	0x2	<p>Analog Comparator 1</p> <p>This trigger is configured by the Analog Comparator Control 1 (ACCTL1) register (page 1789).</p>	0x3	<p>Analog Comparator 2</p> <p>This trigger is configured by the Analog Comparator Control 2 (ACCTL2) register (page 1789).</p>	0x4	<p>External (GPIO Pins)</p> <p>This trigger is connected to the GPIO interrupt for the corresponding GPIO (see “ADC Trigger Source” on page 758).</p>	0x5	<p>Timer</p> <p>In addition, the trigger must be enabled with the $TnOTE$ bit in the GPTMCTL register (page 1110).</p>	0x6	<p>PWM generator 0</p> <p>The PWM generator 0 trigger can be configured with the PWM0 Interrupt and Trigger Enable (PWM0INTEN) register (page 1837).</p>	0x7	<p>PWM generator 1</p> <p>The PWM generator 1 trigger can be configured with the PWM1INTEN register (page 1837).</p>	0x8	<p>PWM generator 2</p> <p>The PWM generator 2 trigger can be configured with the PWM2INTEN register (page 1837).</p>	0x9	<p>PWM generator 3</p> <p>The PWM generator 3 trigger can be configured with the PWM3INTEN register (page 1837).</p>	0xA-0xD	reserved				0xE	Never Trigger (No triggers are allowed to the ADC digital interface)				0xF	Always (continuously sample)			
Value	Event																																								
0x0	<p>Processor (default)</p> <p>The trigger is initiated by setting the SS_n bit in the ADCPSSI register.</p>																																								
0x1	<p>Analog Comparator 0</p> <p>This trigger is configured by the Analog Comparator Control 0 (ACCTL0) register (page 1789).</p>																																								
0x2	<p>Analog Comparator 1</p> <p>This trigger is configured by the Analog Comparator Control 1 (ACCTL1) register (page 1789).</p>																																								
0x3	<p>Analog Comparator 2</p> <p>This trigger is configured by the Analog Comparator Control 2 (ACCTL2) register (page 1789).</p>																																								
0x4	<p>External (GPIO Pins)</p> <p>This trigger is connected to the GPIO interrupt for the corresponding GPIO (see “ADC Trigger Source” on page 758).</p>																																								
0x5	<p>Timer</p> <p>In addition, the trigger must be enabled with the $TnOTE$ bit in the GPTMCTL register (page 1110).</p>																																								
0x6	<p>PWM generator 0</p> <p>The PWM generator 0 trigger can be configured with the PWM0 Interrupt and Trigger Enable (PWM0INTEN) register (page 1837).</p>																																								
0x7	<p>PWM generator 1</p> <p>The PWM generator 1 trigger can be configured with the PWM1INTEN register (page 1837).</p>																																								
0x8	<p>PWM generator 2</p> <p>The PWM generator 2 trigger can be configured with the PWM2INTEN register (page 1837).</p>																																								
0x9	<p>PWM generator 3</p> <p>The PWM generator 3 trigger can be configured with the PWM3INTEN register (page 1837).</p>																																								
0xA-0xD	reserved																																								
0xE	Never Trigger (No triggers are allowed to the ADC digital interface)																																								
0xF	Always (continuously sample)																																								

Bit/Field	Name	Type	Reset	Description																																					
3:0	EM0	RW	0x0	<p>SS0 Trigger Select</p> <p>This field selects the trigger source for Sample Sequencer 0</p> <p>The valid configurations for this field are:</p> <table border="1"> <thead> <tr> <th>Value</th> <th>Event</th> </tr> </thead> <tbody> <tr> <td>0x0</td> <td> <p>Processor (default)</p> <p>The trigger is initiated by setting the SS_n bit in the ADCPSSI register.</p> </td> </tr> <tr> <td>0x1</td> <td> <p>Analog Comparator 0</p> <p>This trigger is configured by the Analog Comparator Control 0 (ACCTL0) register (page 1789).</p> </td> </tr> <tr> <td>0x2</td> <td> <p>Analog Comparator 1</p> <p>This trigger is configured by the Analog Comparator Control 1 (ACCTL1) register (page 1789).</p> </td> </tr> <tr> <td>0x3</td> <td> <p>Analog Comparator 2</p> <p>This trigger is configured by the Analog Comparator Control 2 (ACCTL2) register (page 1789).</p> </td> </tr> <tr> <td>0x4</td> <td> <p>External (GPIO Pins)</p> <p>This trigger is connected to the GPIO interrupt for the corresponding GPIO (see "ADC Trigger Source" on page 758).</p> </td> </tr> <tr> <td>0x5</td> <td> <p>Timer</p> <p>In addition, the trigger must be enabled with the $TnOTE$ bit in the GPTMCTL register (page 1110).</p> </td> </tr> <tr> <td>0x6</td> <td> <p>PWM generator 0</p> <p>The PWM generator 0 trigger can be configured with the PWM0 Interrupt and Trigger Enable (PWM0INTEN) register (page 1837).</p> </td> </tr> <tr> <td>0x7</td> <td> <p>PWM generator 1</p> <p>The PWM generator 1 trigger can be configured with the PWM1INTEN register (page 1837).</p> </td> </tr> <tr> <td>0x8</td> <td> <p>PWM generator 2</p> <p>The PWM generator 2 trigger can be configured with the PWM2INTEN register (page 1837).</p> </td> </tr> <tr> <td>0x9</td> <td> <p>PWM generator 3</p> <p>The PWM generator 3 trigger can be configured with the PWM3INTEN register (page 1837).</p> </td> </tr> <tr> <td>0xA-0xD</td> <td>reserved</td> <td></td> <td></td> <td></td> </tr> <tr> <td>0xE</td> <td>Never Trigger (No triggers are allowed to the ADC digital interface)</td> <td></td> <td></td> <td></td> </tr> <tr> <td>0xF</td> <td>Always (continuously sample)</td> <td></td> <td></td> <td></td> </tr> </tbody> </table>	Value	Event	0x0	<p>Processor (default)</p> <p>The trigger is initiated by setting the SS_n bit in the ADCPSSI register.</p>	0x1	<p>Analog Comparator 0</p> <p>This trigger is configured by the Analog Comparator Control 0 (ACCTL0) register (page 1789).</p>	0x2	<p>Analog Comparator 1</p> <p>This trigger is configured by the Analog Comparator Control 1 (ACCTL1) register (page 1789).</p>	0x3	<p>Analog Comparator 2</p> <p>This trigger is configured by the Analog Comparator Control 2 (ACCTL2) register (page 1789).</p>	0x4	<p>External (GPIO Pins)</p> <p>This trigger is connected to the GPIO interrupt for the corresponding GPIO (see "ADC Trigger Source" on page 758).</p>	0x5	<p>Timer</p> <p>In addition, the trigger must be enabled with the $TnOTE$ bit in the GPTMCTL register (page 1110).</p>	0x6	<p>PWM generator 0</p> <p>The PWM generator 0 trigger can be configured with the PWM0 Interrupt and Trigger Enable (PWM0INTEN) register (page 1837).</p>	0x7	<p>PWM generator 1</p> <p>The PWM generator 1 trigger can be configured with the PWM1INTEN register (page 1837).</p>	0x8	<p>PWM generator 2</p> <p>The PWM generator 2 trigger can be configured with the PWM2INTEN register (page 1837).</p>	0x9	<p>PWM generator 3</p> <p>The PWM generator 3 trigger can be configured with the PWM3INTEN register (page 1837).</p>	0xA-0xD	reserved				0xE	Never Trigger (No triggers are allowed to the ADC digital interface)				0xF	Always (continuously sample)			
Value	Event																																								
0x0	<p>Processor (default)</p> <p>The trigger is initiated by setting the SS_n bit in the ADCPSSI register.</p>																																								
0x1	<p>Analog Comparator 0</p> <p>This trigger is configured by the Analog Comparator Control 0 (ACCTL0) register (page 1789).</p>																																								
0x2	<p>Analog Comparator 1</p> <p>This trigger is configured by the Analog Comparator Control 1 (ACCTL1) register (page 1789).</p>																																								
0x3	<p>Analog Comparator 2</p> <p>This trigger is configured by the Analog Comparator Control 2 (ACCTL2) register (page 1789).</p>																																								
0x4	<p>External (GPIO Pins)</p> <p>This trigger is connected to the GPIO interrupt for the corresponding GPIO (see "ADC Trigger Source" on page 758).</p>																																								
0x5	<p>Timer</p> <p>In addition, the trigger must be enabled with the $TnOTE$ bit in the GPTMCTL register (page 1110).</p>																																								
0x6	<p>PWM generator 0</p> <p>The PWM generator 0 trigger can be configured with the PWM0 Interrupt and Trigger Enable (PWM0INTEN) register (page 1837).</p>																																								
0x7	<p>PWM generator 1</p> <p>The PWM generator 1 trigger can be configured with the PWM1INTEN register (page 1837).</p>																																								
0x8	<p>PWM generator 2</p> <p>The PWM generator 2 trigger can be configured with the PWM2INTEN register (page 1837).</p>																																								
0x9	<p>PWM generator 3</p> <p>The PWM generator 3 trigger can be configured with the PWM3INTEN register (page 1837).</p>																																								
0xA-0xD	reserved																																								
0xE	Never Trigger (No triggers are allowed to the ADC digital interface)																																								
0xF	Always (continuously sample)																																								

Register 7: ADC Underflow Status (ADCUSTAT), offset 0x018

This register indicates underflow conditions in the sample sequencer FIFOs. The corresponding underflow condition is cleared by writing a 1 to the relevant bit position.

ADC Underflow Status (ADCUSTAT)

ADC0 base: 0x4003.8000
 ADC1 base: 0x4003.9000
 Offset 0x018
 Type RW1C, reset 0x0000.0000

	31	30	29	28	27	26	25	24	23	22	21	20	19	18	17	16	
	reserved																
Type	RO	RO	RO	RO	RO	RO	RO	RO	RO	RO	RO	RO	RO	RO	RO	RO	
Reset	0	0	0	0	0	0	0	0	0	0	0	0	0	0	0	0	
	15	14	13	12	11	10	9	8	7	6	5	4	3	2	1	0	
	reserved												UV3	UV2	UV1	UV0	
Type	RO	RO	RO	RO	RO	RO	RO	RO	RO	RO	RO	RO	RO	RW1C	RW1C	RW1C	RW1C
Reset	0	0	0	0	0	0	0	0	0	0	0	0	0	0	0	0	0

Bit/Field	Name	Type	Reset	Description
31:4	reserved	RO	0x0000.000	Software should not rely on the value of a reserved bit. To provide compatibility with future products, the value of a reserved bit should be preserved across a read-modify-write operation.
3	UV3	RW1C	0	SS3 FIFO Underflow The valid configurations for this field are shown below. This bit is cleared by writing a 1. Value Description 0 The FIFO has not underflowed. 1 The FIFO for the Sample Sequencer has hit an underflow condition, meaning that the FIFO is empty and a read was requested. The problematic read does not move the FIFO pointers, and 0s are returned.
2	UV2	RW1C	0	SS2 FIFO Underflow The valid configurations are the same as those for the UV3 field. This bit is cleared by writing a 1.
1	UV1	RW1C	0	SS1 FIFO Underflow The valid configurations are the same as those for the UV3 field. This bit is cleared by writing a 1.
0	UV0	RW1C	0	SS0 FIFO Underflow The valid configurations are the same as those for the UV3 field. This bit is cleared by writing a 1.

Register 8: ADC Trigger Source Select (ADCTSSEL), offset 0x01C

If a PWM Generator n is selected as a trigger source through the EM_n bit field in the **ADC Event Multiplexer Select (ADCEMUX)** register, the **ADCTSSEL** register is programmed to identify in which PWM module instance the generator creating the trigger is located. The register resets to 0x0000.0000, which selects PWM module 0 for all generators. Note that field PS_3 selects the PWM module that maps to Generator 3; PS_2 selects the PWM module that maps to Generator 2, and so on.

ADC Trigger Source Select (ADCTSSEL)

ADC0 base: 0x4003.8000

ADC1 base: 0x4003.9000

Offset 0x01C

Type RW, reset 0x0000.0000

	31	30	29	28	27	26	25	24	23	22	21	20	19	18	17	16
	reserved		PS3		reserved						PS2		reserved			
Type	RO	RO	RW	RW	RO	RO	RO	RO	RO	RO	RW	RW	RO	RO	RO	RO
Reset	0	0	0	0	0	0	0	0	0	0	0	0	0	0	0	0
	15	14	13	12	11	10	9	8	7	6	5	4	3	2	1	0
	reserved		PS1		reserved						PS0		reserved			
Type	RO	RO	RW	RW	RO	RO	RO	RO	RO	RO	RW	RW	RO	RO	RO	RO
Reset	0	0	0	0	0	0	0	0	0	0	0	0	0	0	0	0

Bit/Field	Name	Type	Reset	Description
31:30	reserved	RO	0x0	Software should not rely on the value of a reserved bit. To provide compatibility with future products, the value of a reserved bit should be preserved across a read-modify-write operation.
29:28	PS3	RW	0x0	Generator 3 PWM Module Trigger Select This field selects in which PWM module the generator 3 trigger is located. Value Description 0x0 Use Generator 3 (and its trigger) in PWM module 0 0x1-0x3 reserved
27:22	reserved	RO	0x0	Software should not rely on the value of a reserved bit. To provide compatibility with future products, the value of a reserved bit should be preserved across a read-modify-write operation.
21:20	PS2	RW	0x0	Generator 2 PWM Module Trigger Select This field selects in which PWM module the Generator 2 trigger is located. Value Description 0x0 Use Generator 2 (and its trigger) in PWM module 0 0x1-0x3 reserved
19:14	reserved	RO	0x0	Software should not rely on the value of a reserved bit. To provide compatibility with future products, the value of a reserved bit should be preserved across a read-modify-write operation.

Bit/Field	Name	Type	Reset	Description						
13:12	PS1	RW	0x0	<p>Generator 1 PWM Module Trigger Select</p> <p>This field selects in which PWM module the Generator 1 trigger is located.</p> <table><thead><tr><th>Value</th><th>Description</th></tr></thead><tbody><tr><td>0x0</td><td>Use Generator 1 (and its trigger) in PWM module 0</td></tr><tr><td>0x1-0x3</td><td>reserved</td></tr></tbody></table>	Value	Description	0x0	Use Generator 1 (and its trigger) in PWM module 0	0x1-0x3	reserved
Value	Description									
0x0	Use Generator 1 (and its trigger) in PWM module 0									
0x1-0x3	reserved									
11:6	reserved	RO	0x0	Software should not rely on the value of a reserved bit. To provide compatibility with future products, the value of a reserved bit should be preserved across a read-modify-write operation.						
5:4	PS0	RW	0x0	<p>Generator 0 PWM Module Trigger Select</p> <p>This field selects in which PWM module the Generator 0 trigger is located.</p> <table><thead><tr><th>Value</th><th>Description</th></tr></thead><tbody><tr><td>0x0</td><td>Use Generator 0 (and its trigger) in PWM module 0</td></tr><tr><td>0x1-0x3</td><td>reserved</td></tr></tbody></table>	Value	Description	0x0	Use Generator 0 (and its trigger) in PWM module 0	0x1-0x3	reserved
Value	Description									
0x0	Use Generator 0 (and its trigger) in PWM module 0									
0x1-0x3	reserved									
3:0	reserved	RO	0x0	Software should not rely on the value of a reserved bit. To provide compatibility with future products, the value of a reserved bit should be preserved across a read-modify-write operation.						

Register 9: ADC Sample Sequencer Priority (ADCSSPRI), offset 0x020

This register sets the priority for each of the sample sequencers. Out of reset, Sequencer 0 has the highest priority, and Sequencer 3 has the lowest priority. When reconfiguring sequence priorities, each sequence must have a unique priority for the ADC to operate properly.

ADC Sample Sequencer Priority (ADCSSPRI)

ADC0 base: 0x4003.8000
 ADC1 base: 0x4003.9000
 Offset 0x020
 Type RW, reset 0x0000.3210

	31	30	29	28	27	26	25	24	23	22	21	20	19	18	17	16
	reserved															
Type	RO	RO	RO	RO	RO	RO	RO	RO	RO	RO	RO	RO	RO	RO	RO	RO
Reset	0	0	0	0	0	0	0	0	0	0	0	0	0	0	0	0
	15	14	13	12	11	10	9	8	7	6	5	4	3	2	1	0
	reserved		SS3		reserved		SS2		reserved		SS1		reserved		SS0	
Type	RO	RO	RW	RW	RO	RO	RW	RW	RO	RO	RW	RW	RO	RO	RW	RW
Reset	0	0	1	1	0	0	1	0	0	0	0	1	0	0	0	0

Bit/Field	Name	Type	Reset	Description
31:14	reserved	RO	0x0000.0	Software should not rely on the value of a reserved bit. To provide compatibility with future products, the value of a reserved bit should be preserved across a read-modify-write operation.
13:12	SS3	RW	0x3	SS3 Priority This field contains a binary-encoded value that specifies the priority encoding of Sample Sequencer 3. A priority encoding of 0x0 is highest and 0x3 is lowest. The priorities assigned to the sequencers must be uniquely mapped. The ADC may not operate properly if two or more fields are equal.
11:10	reserved	RO	0x0	Software should not rely on the value of a reserved bit. To provide compatibility with future products, the value of a reserved bit should be preserved across a read-modify-write operation.
9:8	SS2	RW	0x2	SS2 Priority This field contains a binary-encoded value that specifies the priority encoding of Sample Sequencer 2. A priority encoding of 0x0 is highest and 0x3 is lowest. The priorities assigned to the sequencers must be uniquely mapped. The ADC may not operate properly if two or more fields are equal.
7:6	reserved	RO	0x0	Software should not rely on the value of a reserved bit. To provide compatibility with future products, the value of a reserved bit should be preserved across a read-modify-write operation.
5:4	SS1	RW	0x1	SS1 Priority This field contains a binary-encoded value that specifies the priority encoding of Sample Sequencer 1. A priority encoding of 0x0 is highest and 0x3 is lowest. The priorities assigned to the sequencers must be uniquely mapped. The ADC may not operate properly if two or more fields are equal.
3:2	reserved	RO	0x0	Software should not rely on the value of a reserved bit. To provide compatibility with future products, the value of a reserved bit should be preserved across a read-modify-write operation.

Bit/Field	Name	Type	Reset	Description
1:0	SS0	RW	0x0	SS0 Priority This field contains a binary-encoded value that specifies the priority encoding of Sample Sequencer 0. A priority encoding of 0x0 is highest and 0x3 is lowest. The priorities assigned to the sequencers must be uniquely mapped. The ADC may not operate properly if two or more fields are equal.

Register 10: ADC Sample Phase Control (ADCSPC), offset 0x024

The **ADC Sample Phase Control (ADCSPC)** register is used to insert a delay in ADC module sampling. This feature can be used with the **SYNCWAIT** and **GSYNC** bit in the **ADCPSSI** register to provide concurrent sampling of two different signals by two different ADC modules or skewed sampling of two ADC modules to increase the effective sampling rate. For concurrent sampling, the **PHASE** field of each ADC module must be the same and the sample and hold times (**TSH_n**) for the matching sample steps of each ADC must be the same. For example, both ADC0 and ADC1 would program **PHASE = 0x0** in the **ADCSPC** register and might both have the following configuration for their **ADCSSTSH0** register:

- TSH7=0x4
- TSH6=0x2
- TSH5=0x2
- TSH4=0x8
- TSH3=0x6
- TSH2=0x2
- TSH1=0x4
- TSH0=0x2

For skewed sampling with a consistent phase lag, the **TSH_n** field in the **ADCSSTSH_n** register must be the same for all sample steps of an ADC and for both ADC Modules. The desired lag can be calculated by adding the sample and hold time (**TSH_n**) to the twelve clock conversion time to determine the total number of clocks in a sample period. For example to create a 180.0° phase lag, the **PHASE** of the lagging ADC is calculated as:

$$\text{PHASE} = (\text{TSH}_n + 12)/2, \text{ where TSH}_n \text{ is in ADC_Clocks}$$

For situations where a predictable phase lag is not required, sample and hold times (**TSH_n**) of ADC modules can vary.

Note: Care should be taken when the **PHASE** field is non-zero, as the resulting delay in sampling the **AIN_x** input may result in undesirable system consequences. The time from ADC trigger to sample is increased and could make the response time longer than anticipated. The added latency could have ramifications in the system design. Designers should carefully consider the impact of this delay.

ADC Sample Phase Control (ADCSPC)

ADC0 base: 0x4003.8000
 ADC1 base: 0x4003.9000
 Offset 0x024
 Type RW, reset 0x0000.0000

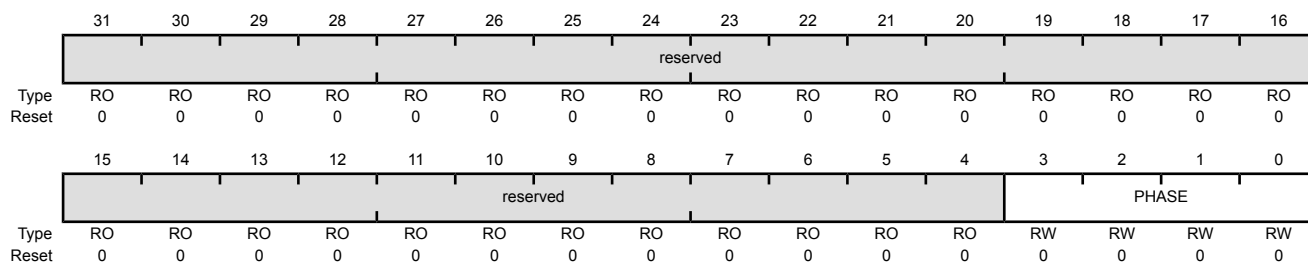

Bit/Field	Name	Type	Reset	Description
31:4	reserved	RO	0x0000.000	Software should not rely on the value of a reserved bit. To provide compatibility with future products, the value of a reserved bit should be preserved across a read-modify-write operation.
3:0	PHASE	RW	0x0	Phase Lag This field selects the sample phase lag from the standard sample time.

Value	Description
0x0	The ADC samples are concurrent.
0x1	The ADC sample lags by 1 ADC clock
0x2	The ADC sample lags by 2 ADC clocks
0x3	The ADC sample lags by 3 ADC clocks
0x4	The ADC sample lags by 4 clocks
0x5	The ADC sample lags by 5 clocks
0x6	The ADC sample lags by 6 clocks
0x7	The ADC sample lags by 7 clocks
0x8	The ADC sample lags by 8 clocks
0x9	The ADC sample lags by 9 clocks
0xA	The ADC sample lags by 10 clocks
0xB	The ADC sample lags by 11 clocks
0xC	The ADC sample lags by 12 clocks
0xD	The ADC sample lags by 13 clocks
0xE	The ADC sample lags by 14 clocks
0xF	The ADC sample lags by 15 clocks

Register 11: ADC Processor Sample Sequence Initiate (ADCPSSI), offset 0x028

This register provides a mechanism for application software to initiate sampling in the sample sequencers. Sample sequences can be initiated individually or in any combination. When multiple sequences are triggered simultaneously, the priority encodings in **ADCSSPRI** dictate execution order.

This register also provides a means to configure and then initiate concurrent sampling on all ADC modules. To do this, the first ADC module should be configured. The **ADCPSSI** register for that module should then be written. The appropriate **SS** bits should be set along with the **SYNCWAIT** bit. Additional ADC modules should then be configured following the same procedure. Once the final ADC module is configured, its **ADCPSSI** register should be written with the appropriate **SS** bits set along with the **GSYNC** bit. All of the ADC modules then begin concurrent sampling according to their configuration.

ADC Processor Sample Sequence Initiate (ADCPSSI)

ADC0 base: 0x4003.8000

ADC1 base: 0x4003.9000

Offset 0x028

Type RW, reset -

	31	30	29	28	27	26	25	24	23	22	21	20	19	18	17	16	
	GSYNC	reserved				SYNCWAIT	reserved										
Type	RW	RO	RO	RO	RW	RO	RO	RO	RO	RO	RO	RO	RO	RO	RO	RO	
Reset	0	0	0	0	0	0	0	0	0	0	0	0	0	0	0	0	
	15	14	13	12	11	10	9	8	7	6	5	4	3	2	1	0	
	reserved												SS3	SS2	SS1	SS0	
Type	RO	RO	RO	RO	RO	RO	RO	RO	RO	RO	RO	RO	RO	WO	WO	WO	WO
Reset	0	0	0	0	0	0	0	0	0	0	0	0	0	-	-	-	-

Bit/Field	Name	Type	Reset	Description
31	GSYNC	RW	0	Global Synchronize
				Value Description
				0 This bit is cleared once sampling has been initiated.
				1 This bit initiates sampling in multiple ADC modules at the same time. Any ADC module that has been initialized by setting an SS_n bit and the SYNCWAIT bit starts sampling once this bit is written.
30:28	reserved	RO	0x0	Software should not rely on the value of a reserved bit. To provide compatibility with future products, the value of a reserved bit should be preserved across a read-modify-write operation.
27	SYNCWAIT	RW	0	Synchronize Wait
				Value Description
				0 Sampling begins when a sample sequence has been initiated.
				1 This bit allows the sample sequences to be initiated, but delays sampling until the GSYNC bit is set.
26:4	reserved	RO	0x0000.0	Software should not rely on the value of a reserved bit. To provide compatibility with future products, the value of a reserved bit should be preserved across a read-modify-write operation.

Bit/Field	Name	Type	Reset	Description
3	SS3	WO	-	<p>SS3 Initiate</p> <p>Value Description</p> <p>0 No effect.</p> <p>1 Begin sampling on Sample Sequencer 3, if the sequencer is enabled in the ADCACTSS register.</p> <p>Only a write by software is valid; a read of this register returns no meaningful data.</p>
2	SS2	WO	-	<p>SS2 Initiate</p> <p>Value Description</p> <p>0 No effect.</p> <p>1 Begin sampling on Sample Sequencer 2, if the sequencer is enabled in the ADCACTSS register.</p> <p>Only a write by software is valid; a read of this register returns no meaningful data.</p>
1	SS1	WO	-	<p>SS1 Initiate</p> <p>Value Description</p> <p>0 No effect.</p> <p>1 Begin sampling on Sample Sequencer 1, if the sequencer is enabled in the ADCACTSS register.</p> <p>Only a write by software is valid; a read of this register returns no meaningful data.</p>
0	SS0	WO	-	<p>SS0 Initiate</p> <p>Value Description</p> <p>0 No effect.</p> <p>1 Begin sampling on Sample Sequencer 0, if the sequencer is enabled in the ADCACTSS register.</p> <p>Only a write by software is valid; a read of this register returns no meaningful data.</p>

Register 12: ADC Sample Averaging Control (ADCSAC), offset 0x030

This register controls the amount of hardware averaging applied to conversion results. The final conversion result stored in the FIFO is averaged from 2^{AVG} consecutive ADC samples at the specified ADC speed. If AVG is 0, the sample is passed directly through without any averaging. If AVG=6, then 64 consecutive ADC samples are averaged to generate one result in the sequencer FIFO. An AVG=7 provides unpredictable results.

ADC Sample Averaging Control (ADCSAC)

ADC0 base: 0x4003.8000
 ADC1 base: 0x4003.9000
 Offset 0x030
 Type RW, reset 0x0000.0000

	31	30	29	28	27	26	25	24	23	22	21	20	19	18	17	16	
	reserved																
Type	RO	RO	RO	RO	RO	RO	RO	RO	RO	RO	RO	RO	RO	RO	RO	RO	
Reset	0	0	0	0	0	0	0	0	0	0	0	0	0	0	0	0	
	15	14	13	12	11	10	9	8	7	6	5	4	3	2	1	0	
	reserved													AVG			
Type	RO	RO	RO	RO	RO	RO	RO	RO	RO	RO	RO	RO	RO	RO	RW	RW	RW
Reset	0	0	0	0	0	0	0	0	0	0	0	0	0	0	0	0	0

Bit/Field	Name	Type	Reset	Description
31:3	reserved	RO	0x0000.000	Software should not rely on the value of a reserved bit. To provide compatibility with future products, the value of a reserved bit should be preserved across a read-modify-write operation.
2:0	AVG	RW	0x0	Hardware Averaging Control Specifies the amount of hardware averaging that will be applied to ADC samples. The AVG field can be any value between 0 and 6. Entering a value of 7 creates unpredictable results.
				Value Description
				0x0 No hardware oversampling
				0x1 2x hardware oversampling
				0x2 4x hardware oversampling
				0x3 8x hardware oversampling
				0x4 16x hardware oversampling
				0x5 32x hardware oversampling
				0x6 64x hardware oversampling
				0x7 reserved

Register 13: ADC Digital Comparator Interrupt Status and Clear (ADCDISC), offset 0x034

This register provides status and acknowledgement of digital comparator interrupts. One bit is provided for each comparator.

ADC Digital Comparator Interrupt Status and Clear (ADCDISC)

ADC0 base: 0x4003.8000
 ADC1 base: 0x4003.9000
 Offset 0x034
 Type RW1C, reset 0x0000.0000

	31	30	29	28	27	26	25	24	23	22	21	20	19	18	17	16
	reserved															
Type	RO	RO	RO	RO	RO	RO	RO	RO	RO	RO	RO	RO	RO	RO	RO	RO
Reset	0	0	0	0	0	0	0	0	0	0	0	0	0	0	0	0
	15	14	13	12	11	10	9	8	7	6	5	4	3	2	1	0
	reserved								DCINT7	DCINT6	DCINT5	DCINT4	DCINT3	DCINT2	DCINT1	DCINT0
Type	RO	RO	RO	RO	RO	RO	RO	RO	RW1C	RW1C	RW1C	RW1C	RW1C	RW1C	RW1C	RW1C
Reset	0	0	0	0	0	0	0	0	0	0	0	0	0	0	0	0

Bit/Field	Name	Type	Reset	Description
31:8	reserved	RO	0x0000.00	Software should not rely on the value of a reserved bit. To provide compatibility with future products, the value of a reserved bit should be preserved across a read-modify-write operation.
7	DCINT7	RW1C	0	Digital Comparator 7 Interrupt Status and Clear Value Description 0 No interrupt. 1 Digital Comparator 7 has generated an interrupt. This bit is cleared by writing a 1.
6	DCINT6	RW1C	0	Digital Comparator 6 Interrupt Status and Clear Value Description 0 No interrupt. 1 Digital Comparator 6 has generated an interrupt. This bit is cleared by writing a 1.
5	DCINT5	RW1C	0	Digital Comparator 5 Interrupt Status and Clear Value Description 0 No interrupt. 1 Digital Comparator 5 has generated an interrupt. This bit is cleared by writing a 1.

Bit/Field	Name	Type	Reset	Description
4	DCINT4	RW1C	0	<p>Digital Comparator 4 Interrupt Status and Clear</p> <p>Value Description</p> <p>0 No interrupt.</p> <p>1 Digital Comparator 4 has generated an interrupt.</p> <p>This bit is cleared by writing a 1.</p>
3	DCINT3	RW1C	0	<p>Digital Comparator 3 Interrupt Status and Clear</p> <p>Value Description</p> <p>0 No interrupt.</p> <p>1 Digital Comparator 3 has generated an interrupt.</p> <p>This bit is cleared by writing a 1.</p>
2	DCINT2	RW1C	0	<p>Digital Comparator 2 Interrupt Status and Clear</p> <p>Value Description</p> <p>0 No interrupt.</p> <p>1 Digital Comparator 2 has generated an interrupt.</p> <p>This bit is cleared by writing a 1.</p>
1	DCINT1	RW1C	0	<p>Digital Comparator 1 Interrupt Status and Clear</p> <p>Value Description</p> <p>0 No interrupt.</p> <p>1 Digital Comparator 1 has generated an interrupt.</p> <p>This bit is cleared by writing a 1.</p>
0	DCINT0	RW1C	0	<p>Digital Comparator 0 Interrupt Status and Clear</p> <p>Value Description</p> <p>0 No interrupt.</p> <p>1 Digital Comparator 0 has generated an interrupt.</p> <p>This bit is cleared by writing a 1.</p>

Register 14: ADC Control (ADCCTL), offset 0x038

This register configures the voltage reference. The voltage references for the conversion can be V_{REFA+} and G_{NDA} or V_{DDA} and G_{NDA} . Note that values set in this register apply to all ADC modules, it is not possible to set one module to use internal references and another to use external references.

ADC Control (ADCCTL)

ADC0 base: 0x4003.8000
 ADC1 base: 0x4003.9000
 Offset 0x038
 Type RW, reset 0x0000.0000

	31	30	29	28	27	26	25	24	23	22	21	20	19	18	17	16	
	reserved																
Type	RO	RO	RO	RO	RO	RO	RO	RO	RO	RO	RO	RO	RO	RO	RO	RO	
Reset	0	0	0	0	0	0	0	0	0	0	0	0	0	0	0	0	
	15	14	13	12	11	10	9	8	7	6	5	4	3	2	1	0	
	reserved															VREF	
Type	RO	RO	RO	RO	RO	RO	RO	RO	RO	RO	RO	RO	RO	RO	RO	RO	RW
Reset	0	0	0	0	0	0	0	0	0	0	0	0	0	0	0	0	0

Bit/Field	Name	Type	Reset	Description
31:1	reserved	RO	0x0000.000	Software should not rely on the value of a reserved bit. To provide compatibility with future products, the value of a reserved bit should be preserved across a read-modify-write operation.
0	VREF	RW	0x0	Voltage Reference Select
				Value Description
			0x0	V_{DDA} and G_{NDA} are the voltage references for all ADC modules.
			0x1	The external V_{REFA+} and G_{NDA} are the voltage references for all ADC modules.

Register 15: ADC Sample Sequence Input Multiplexer Select 0 (ADCSSMUX0), offset 0x040

This register, along with the **ADCSSMUX0** register, defines the analog input configuration for each sample in a sequence executed with Sample Sequencer 0. If the corresponding **EMUX_n** bit in the **ADCSSMUX0** register is set, the **MUX_n** field in this register selects from **AIN[19:16]**. When the corresponding **EMUX_n** bit is clear, the **MUX_n** field selects from **AIN[15:0]**. This register is 32 bits wide and contains information for eight possible samples.

Note: Channels **AIN[31:20]** do not exist on this microcontroller. Configuring **MUX_n** to be 0xC-0xF when the corresponding **EMUX_n** bit is set results in undefined behavior.

ADC Sample Sequence Input Multiplexer Select 0 (ADCSSMUX0)

ADC0 base: 0x4003.8000
 ADC1 base: 0x4003.9000
 Offset 0x040
 Type RW, reset 0x0000.0000

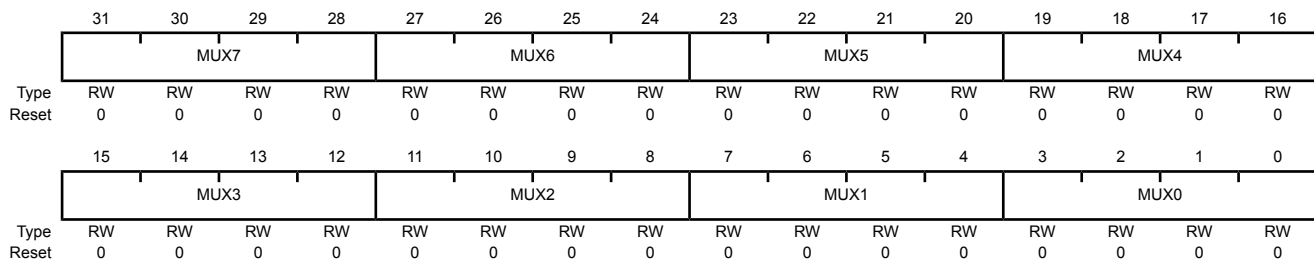

Bit/Field	Name	Type	Reset	Description
31:28	MUX7	RW	0x0	<p>8th Sample Input Select</p> <p>The MUX7 field is used during the eighth sample of a sequence executed with the sample sequencer. It specifies which of the analog inputs is sampled for the analog-to-digital conversion. The value set here indicates the corresponding pin, for example, a value of 0x1 when EMUX7 is clear indicates the input is AIN1. A value of 0x1 when EMUX7 is set indicates the input is AIN17.</p> <p>If differential sampling is enabled (the D7 bit in the ADCSSCTL0 register is set), this field must be set to the pair number "i", where the paired inputs are "2i and 2i+1".</p>
27:24	MUX6	RW	0x0	<p>7th Sample Input Select</p> <p>The MUX6 field is used during the seventh sample of a sequence executed with the sample sequencer. It specifies which of the analog inputs is sampled for the analog-to-digital conversion.</p>
23:20	MUX5	RW	0x0	<p>6th Sample Input Select</p> <p>The MUX5 field is used during the sixth sample of a sequence executed with the sample sequencer. It specifies which of the analog inputs is sampled for the analog-to-digital conversion.</p>
19:16	MUX4	RW	0x0	<p>5th Sample Input Select</p> <p>The MUX4 field is used during the fifth sample of a sequence executed with the sample sequencer. It specifies which of the analog inputs is sampled for the analog-to-digital conversion.</p>

Bit/Field	Name	Type	Reset	Description
15:12	MUX3	RW	0x0	4th Sample Input Select The MUX3 field is used during the fourth sample of a sequence executed with the sample sequencer. It specifies which of the analog inputs is sampled for the analog-to-digital conversion.
11:8	MUX2	RW	0x0	3rd Sample Input Select The MUX2 field is used during the third sample of a sequence executed with the sample sequencer. It specifies which of the analog inputs is sampled for the analog-to-digital conversion.
7:4	MUX1	RW	0x0	2nd Sample Input Select The MUX1 field is used during the second sample of a sequence executed with the sample sequencer. It specifies which of the analog inputs is sampled for the analog-to-digital conversion.
3:0	MUX0	RW	0x0	1st Sample Input Select The MUX0 field is used during the first sample of a sequence executed with the sample sequencer. It specifies which of the analog inputs is sampled for the analog-to-digital conversion.

Register 16: ADC Sample Sequence Control 0 (ADCSSCTL0), offset 0x044

This register contains the configuration information for each sample for a sequence executed with a sample sequencer. When configuring a sample sequence, the `END` bit must be set for the final sample, whether it be after the first sample, eighth sample, or any sample in between. This register is 32 bits wide and contains information for eight possible samples.

ADC Sample Sequence Control 0 (ADCSSCTL0)

ADC0 base: 0x4003.8000
 ADC1 base: 0x4003.9000
 Offset 0x044
 Type RW, reset 0x0000.0000

	31	30	29	28	27	26	25	24	23	22	21	20	19	18	17	16
	TS7	IE7	END7	D7	TS6	IE6	END6	D6	TS5	IE5	END5	D5	TS4	IE4	END4	D4
Type	RW	RW	RW	RW	RW	RW	RW	RW	RW	RW	RW	RW	RW	RW	RW	RW
Reset	0	0	0	0	0	0	0	0	0	0	0	0	0	0	0	0
	15	14	13	12	11	10	9	8	7	6	5	4	3	2	1	0
	TS3	IE3	END3	D3	TS2	IE2	END2	D2	TS1	IE1	END1	D1	TS0	IE0	END0	D0
Type	RW	RW	RW	RW	RW	RW	RW	RW	RW	RW	RW	RW	RW	RW	RW	RW
Reset	0	0	0	0	0	0	0	0	0	0	0	0	0	0	0	0

Bit/Field	Name	Type	Reset	Description
31	TS7	RW	0	8th Sample Temp Sensor Select
				Value Description
				0 The input pin specified by the ADCSSMUXn register is read during the eighth sample of the sample sequence.
				1 The temperature sensor is read during the eighth sample of the sample sequence.
30	IE7	RW	0	8th Sample Interrupt Enable
				Value Description
				0 The raw interrupt is not asserted to the interrupt controller.
				1 The raw interrupt signal (INR0 bit) is asserted at the end of the eighth sample's conversion. If the MASK0 bit in the ADCIM register is set, the interrupt is promoted to the interrupt controller.
				It is legal to have multiple samples within a sequence generate interrupts.
29	END7	RW	0	8th Sample is End of Sequence
				Value Description
				0 Another sample in the sequence is the final sample.
				1 The eighth sample is the last sample of the sequence.
				It is possible to end the sequence on any sample position. Software must set an ENDn bit somewhere within the sequence. Samples defined after the sample containing a set ENDn bit are not requested for conversion even though the fields may be non-zero.

Bit/Field	Name	Type	Reset	Description
28	D7	RW	0	<p>8th Sample Differential Input Select</p> <p>Value Description</p> <p>0 The analog inputs are not differentially sampled.</p> <p>1 The analog input is differentially sampled. The corresponding ADCSSMUXn nibble must be set to the pair number "i", where the paired inputs are "2i and 2i+1".</p> <p>Because the temperature sensor does not have a differential option, this bit must not be set when the TS7 bit is set.</p>
27	TS6	RW	0	<p>7th Sample Temp Sensor Select</p> <p>Value Description</p> <p>0 The input pin specified by the ADCSSMUXn register is read during the seventh sample of the sample sequence.</p> <p>1 The temperature sensor is read during the seventh sample of the sample sequence.</p>
26	IE6	RW	0	<p>7th Sample Interrupt Enable</p> <p>Value Description</p> <p>0 The raw interrupt is not asserted to the interrupt controller.</p> <p>1 The raw interrupt signal (INR0 bit) is asserted at the end of the seventh sample's conversion. If the MASK0 bit in the ADCIM register is set, the interrupt is promoted to the interrupt controller.</p> <p>It is legal to have multiple samples within a sequence generate interrupts.</p>
25	END6	RW	0	<p>7th Sample is End of Sequence</p> <p>Value Description</p> <p>0 Another sample in the sequence is the final sample.</p> <p>1 The seventh sample is the last sample of the sequence.</p> <p>It is possible to end the sequence on any sample position. Software must set an ENDn bit somewhere within the sequence. Samples defined after the sample containing a set ENDn bit are not requested for conversion even though the fields may be non-zero.</p>
24	D6	RW	0	<p>7th Sample Differential Input Select</p> <p>Value Description</p> <p>0 The analog inputs are not differentially sampled.</p> <p>1 The analog input is differentially sampled. The corresponding ADCSSMUXn nibble must be set to the pair number "i", where the paired inputs are "2i and 2i+1".</p> <p>Because the temperature sensor does not have a differential option, this bit must not be set when the TS6 bit is set.</p>

Bit/Field	Name	Type	Reset	Description
23	TS5	RW	0	<p>6th Sample Temp Sensor Select</p> <p>Value Description</p> <p>0 The input pin specified by the ADCSSMUXn register is read during the sixth sample of the sample sequence.</p> <p>1 The temperature sensor is read during the sixth sample of the sample sequence.</p>
22	IE5	RW	0	<p>6th Sample Interrupt Enable</p> <p>Value Description</p> <p>0 The raw interrupt is not asserted to the interrupt controller.</p> <p>1 The raw interrupt signal (INR0 bit) is asserted at the end of the sixth sample's conversion. If the MASK0 bit in the ADCIM register is set, the interrupt is promoted to the interrupt controller.</p> <p>It is legal to have multiple samples within a sequence generate interrupts.</p>
21	END5	RW	0	<p>6th Sample is End of Sequence</p> <p>Value Description</p> <p>0 Another sample in the sequence is the final sample.</p> <p>1 The sixth sample is the last sample of the sequence.</p> <p>It is possible to end the sequence on any sample position. Software must set an ENDn bit somewhere within the sequence. Samples defined after the sample containing a set ENDn bit are not requested for conversion even though the fields may be non-zero.</p>
20	D5	RW	0	<p>6th Sample Differential Input Select</p> <p>Value Description</p> <p>0 The analog inputs are not differentially sampled.</p> <p>1 The analog input is differentially sampled. The corresponding ADCSSMUXn nibble must be set to the pair number "i", where the paired inputs are "2i and 2i+1".</p> <p>Because the temperature sensor does not have a differential option, this bit must not be set when the TS5 bit is set.</p>
19	TS4	RW	0	<p>5th Sample Temp Sensor Select</p> <p>Value Description</p> <p>0 The input pin specified by the ADCSSMUXn register is read during the fifth sample of the sample sequence.</p> <p>1 The temperature sensor is read during the fifth sample of the sample sequence.</p>

Bit/Field	Name	Type	Reset	Description
18	IE4	RW	0	<p>5th Sample Interrupt Enable</p> <p>Value Description</p> <p>0 The raw interrupt is not asserted to the interrupt controller.</p> <p>1 The raw interrupt signal (INR0 bit) is asserted at the end of the fifth sample's conversion. If the MASK0 bit in the ADCIM register is set, the interrupt is promoted to the interrupt controller.</p> <p>It is legal to have multiple samples within a sequence generate interrupts.</p>
17	END4	RW	0	<p>5th Sample is End of Sequence</p> <p>Value Description</p> <p>0 Another sample in the sequence is the final sample.</p> <p>1 The fifth sample is the last sample of the sequence.</p> <p>It is possible to end the sequence on any sample position. Software must set an ENDn bit somewhere within the sequence. Samples defined after the sample containing a set ENDn bit are not requested for conversion even though the fields may be non-zero.</p>
16	D4	RW	0	<p>5th Sample Differential Input Select</p> <p>Value Description</p> <p>0 The analog inputs are not differentially sampled.</p> <p>1 The analog input is differentially sampled. The corresponding ADCSSMUXn nibble must be set to the pair number "i", where the paired inputs are "2i and 2i+1".</p> <p>Because the temperature sensor does not have a differential option, this bit must not be set when the TS4 bit is set.</p>
15	TS3	RW	0	<p>4th Sample Temp Sensor Select</p> <p>Value Description</p> <p>0 The input pin specified by the ADCSSMUXn register is read during the fourth sample of the sample sequence.</p> <p>1 The temperature sensor is read during the fourth sample of the sample sequence.</p>
14	IE3	RW	0	<p>4th Sample Interrupt Enable</p> <p>Value Description</p> <p>0 The raw interrupt is not asserted to the interrupt controller.</p> <p>1 The raw interrupt signal (INR0 bit) is asserted at the end of the fourth sample's conversion. If the MASK0 bit in the ADCIM register is set, the interrupt is promoted to the interrupt controller.</p> <p>It is legal to have multiple samples within a sequence generate interrupts.</p>

Bit/Field	Name	Type	Reset	Description
13	END3	RW	0	<p>4th Sample is End of Sequence</p> <p>Value Description</p> <p>0 Another sample in the sequence is the final sample.</p> <p>1 The fourth sample is the last sample of the sequence.</p> <p>It is possible to end the sequence on any sample position. Software must set an <code>END_n</code> bit somewhere within the sequence. Samples defined after the sample containing a set <code>END_n</code> bit are not requested for conversion even though the fields may be non-zero.</p>
12	D3	RW	0	<p>4th Sample Differential Input Select</p> <p>Value Description</p> <p>0 The analog inputs are not differentially sampled.</p> <p>1 The analog input is differentially sampled. The corresponding ADCSSMUX_n nibble must be set to the pair number "i", where the paired inputs are "2i and 2i+1".</p> <p>Because the temperature sensor does not have a differential option, this bit must not be set when the <code>TS3</code> bit is set.</p>
11	TS2	RW	0	<p>3rd Sample Temp Sensor Select</p> <p>Value Description</p> <p>0 The input pin specified by the ADCSSMUX_n register is read during the third sample of the sample sequence.</p> <p>1 The temperature sensor is read during the third sample of the sample sequence.</p>
10	IE2	RW	0	<p>3rd Sample Interrupt Enable</p> <p>Value Description</p> <p>0 The raw interrupt is not asserted to the interrupt controller.</p> <p>1 The raw interrupt signal (<code>INR0</code> bit) is asserted at the end of the third sample's conversion. If the <code>MASK0</code> bit in the ADCIM register is set, the interrupt is promoted to the interrupt controller.</p> <p>It is legal to have multiple samples within a sequence generate interrupts.</p>
9	END2	RW	0	<p>3rd Sample is End of Sequence</p> <p>Value Description</p> <p>0 Another sample in the sequence is the final sample.</p> <p>1 The third sample is the last sample of the sequence.</p> <p>It is possible to end the sequence on any sample position. Software must set an <code>END_n</code> bit somewhere within the sequence. Samples defined after the sample containing a set <code>END_n</code> bit are not requested for conversion even though the fields may be non-zero.</p>

Bit/Field	Name	Type	Reset	Description
8	D2	RW	0	<p>3rd Sample Differential Input Select</p> <p>Value Description</p> <p>0 The analog inputs are not differentially sampled.</p> <p>1 The analog input is differentially sampled. The corresponding ADCSSMUXn nibble must be set to the pair number "i", where the paired inputs are "2i and 2i+1".</p> <p>Because the temperature sensor does not have a differential option, this bit must not be set when the TS2 bit is set.</p>
7	TS1	RW	0	<p>2nd Sample Temp Sensor Select</p> <p>Value Description</p> <p>0 The input pin specified by the ADCSSMUXn register is read during the second sample of the sample sequence.</p> <p>1 The temperature sensor is read during the second sample of the sample sequence.</p>
6	IE1	RW	0	<p>2nd Sample Interrupt Enable</p> <p>Value Description</p> <p>0 The raw interrupt is not asserted to the interrupt controller.</p> <p>1 The raw interrupt signal (INR0 bit) is asserted at the end of the second sample's conversion. If the MASK0 bit in the ADCIM register is set, the interrupt is promoted to the interrupt controller.</p> <p>It is legal to have multiple samples within a sequence generate interrupts.</p>
5	END1	RW	0	<p>2nd Sample is End of Sequence</p> <p>Value Description</p> <p>0 Another sample in the sequence is the final sample.</p> <p>1 The second sample is the last sample of the sequence.</p> <p>It is possible to end the sequence on any sample position. Software must set an ENDn bit somewhere within the sequence. Samples defined after the sample containing a set ENDn bit are not requested for conversion even though the fields may be non-zero.</p>
4	D1	RW	0	<p>2nd Sample Differential Input Select</p> <p>Value Description</p> <p>0 The analog inputs are not differentially sampled.</p> <p>1 The analog input is differentially sampled. The corresponding ADCSSMUXn nibble must be set to the pair number "i", where the paired inputs are "2i and 2i+1".</p> <p>Because the temperature sensor does not have a differential option, this bit must not be set when the TS1 bit is set.</p>

Bit/Field	Name	Type	Reset	Description
3	TS0	RW	0	<p>1st Sample Temp Sensor Select</p> <p>Value Description</p> <p>0 The input pin specified by the ADCSSMUXn register is read during the first sample of the sample sequence.</p> <p>1 The temperature sensor is read during the first sample of the sample sequence.</p>
2	IE0	RW	0	<p>1st Sample Interrupt Enable</p> <p>Value Description</p> <p>0 The raw interrupt is not asserted to the interrupt controller.</p> <p>1 The raw interrupt signal (INR0 bit) is asserted at the end of the first sample's conversion. If the MASK0 bit in the ADCIM register is set, the interrupt is promoted to the interrupt controller.</p> <p>It is legal to have multiple samples within a sequence generate interrupts.</p>
1	END0	RW	0	<p>1st Sample is End of Sequence</p> <p>Value Description</p> <p>0 Another sample in the sequence is the final sample.</p> <p>1 The first sample is the last sample of the sequence.</p> <p>It is possible to end the sequence on any sample position. Software must set an ENDn bit somewhere within the sequence. Samples defined after the sample containing a set ENDn bit are not requested for conversion even though the fields may be non-zero.</p>
0	D0	RW	0	<p>1st Sample Differential Input Select</p> <p>Value Description</p> <p>0 The analog inputs are not differentially sampled.</p> <p>1 The analog input is differentially sampled. The corresponding ADCSSMUXn nibble must be set to the pair number "i", where the paired inputs are "2i and 2i+1".</p> <p>Because the temperature sensor does not have a differential option, this bit must not be set when the TS0 bit is set.</p>

Register 17: ADC Sample Sequence Result FIFO 0 (ADCSSFIFO0), offset 0x048

Register 18: ADC Sample Sequence Result FIFO 1 (ADCSSFIFO1), offset 0x068

Register 19: ADC Sample Sequence Result FIFO 2 (ADCSSFIFO2), offset 0x088

Register 20: ADC Sample Sequence Result FIFO 3 (ADCSSFIFO3), offset 0x0A8

Important: This register is read-sensitive. See the register description for details.

This register contains the conversion results for samples collected with the sample sequencer (the **ADCSSFIFO0** register is used for Sample Sequencer 0, **ADCSSFIFO1** for Sequencer 1, **ADCSSFIFO2** for Sequencer 2, and **ADCSSFIFO3** for Sequencer 3). Reads of this register return conversion result data in the order sample 0, sample 1, and so on, until the FIFO is empty. If the FIFO is not properly handled by software, overflow and underflow conditions are registered in the **ADCOSTAT** and **ADCUSTAT** registers.

ADC Sample Sequence Result FIFO n (ADCSSFIFO_n)

ADC0 base: 0x4003.8000
 ADC1 base: 0x4003.9000
 Offset 0x048
 Type RO, reset -

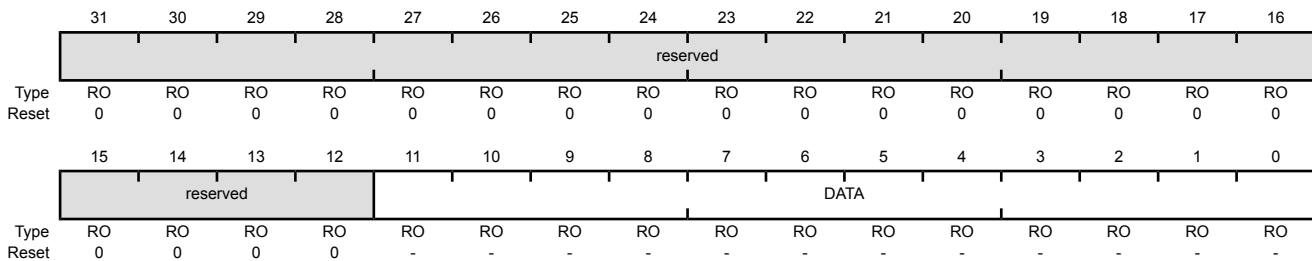

Bit/Field	Name	Type	Reset	Description
31:12	reserved	RO	0x0000.0	Software should not rely on the value of a reserved bit. To provide compatibility with future products, the value of a reserved bit should be preserved across a read-modify-write operation.
11:0	DATA	RO	-	Conversion Result Data

Register 21: ADC Sample Sequence FIFO 0 Status (ADCSSFSTAT0), offset 0x04C

Register 22: ADC Sample Sequence FIFO 1 Status (ADCSSFSTAT1), offset 0x06C

Register 23: ADC Sample Sequence FIFO 2 Status (ADCSSFSTAT2), offset 0x08C

Register 24: ADC Sample Sequence FIFO 3 Status (ADCSSFSTAT3), offset 0x0AC

This register provides a window into the sample sequencer, providing full/empty status information as well as the positions of the head and tail pointers. The reset value of 0x100 indicates an empty FIFO with the head and tail pointers both pointing to index 0. The **ADCSSFSTAT0** register provides status on FIFO0, which has 8 entries; **ADCSSFSTAT1** on FIFO1, which has 4 entries; **ADCSSFSTAT2** on FIFO2, which has 4 entries; and **ADCSSFSTAT3** on FIFO3 which has a single entry.

ADC Sample Sequence FIFO n Status (ADCSSFSTATn)

ADC0 base: 0x4003.8000
 ADC1 base: 0x4003.9000
 Offset 0x04C
 Type RO, reset 0x0000.0100

	31	30	29	28	27	26	25	24	23	22	21	20	19	18	17	16
	reserved															
Type	RO	RO	RO	RO	RO	RO	RO	RO	RO	RO	RO	RO	RO	RO	RO	RO
Reset	0	0	0	0	0	0	0	0	0	0	0	0	0	0	0	0
	15	14	13	12	11	10	9	8	7	6	5	4	3	2	1	0
	reserved			FULL	reserved			EMPTY	HPTR				TPTR			
Type	RO	RO	RO	RO	RO	RO	RO	RO	RO	RO	RO	RO	RO	RO	RO	RO
Reset	0	0	0	0	0	0	0	1	0	0	0	0	0	0	0	0

Bit/Field	Name	Type	Reset	Description
31:13	reserved	RO	0x0000.0	Software should not rely on the value of a reserved bit. To provide compatibility with future products, the value of a reserved bit should be preserved across a read-modify-write operation.
12	FULL	RO	0	FIFO Full Value Description 0 The FIFO is not currently full. 1 The FIFO is currently full.
11:9	reserved	RO	0x0	Software should not rely on the value of a reserved bit. To provide compatibility with future products, the value of a reserved bit should be preserved across a read-modify-write operation.
8	EMPTY	RO	1	FIFO Empty Value Description 0 The FIFO is not currently empty. 1 The FIFO is currently empty.

Bit/Field	Name	Type	Reset	Description
7:4	HPTR	RO	0x0	FIFO Head Pointer This field contains the current "head" pointer index for the FIFO, that is, the next entry to be written. Valid values are 0x0-0x7 for FIFO0; 0x0-0x3 for FIFO1 and FIFO2; and 0x0 for FIFO3.
3:0	TPTR	RO	0x0	FIFO Tail Pointer This field contains the current "tail" pointer index for the FIFO, that is, the next entry to be read. Valid values are 0x0-0x7 for FIFO0; 0x0-0x3 for FIFO1 and FIFO2; and 0x0 for FIFO3.

Register 25: ADC Sample Sequence 0 Operation (ADCSSOP0), offset 0x050

This register determines whether the sample from the given conversion on Sample Sequence 0 is saved in the Sample Sequence FIFO0 or sent to the digital comparator unit.

ADC Sample Sequence 0 Operation (ADCSSOP0)

ADC0 base: 0x4003.8000
 ADC1 base: 0x4003.9000
 Offset 0x050
 Type RW, reset 0x0000.0000

	31	30	29	28	27	26	25	24	23	22	21	20	19	18	17	16
	reserved			S7DCOP	reserved			S6DCOP	reserved			S5DCOP	reserved			S4DCOP
Type	RO	RO	RO	RW	RO	RO	RO	RW	RO	RO	RO	RW	RO	RO	RO	RW
Reset	0	0	0	0	0	0	0	0	0	0	0	0	0	0	0	0
	15	14	13	12	11	10	9	8	7	6	5	4	3	2	1	0
	reserved			S3DCOP	reserved			S2DCOP	reserved			S1DCOP	reserved			S0DCOP
Type	RO	RO	RO	RW	RO	RO	RO	RW	RO	RO	RO	RW	RO	RO	RO	RW
Reset	0	0	0	0	0	0	0	0	0	0	0	0	0	0	0	0

Bit/Field	Name	Type	Reset	Description
31:29	reserved	RO	0x0	Software should not rely on the value of a reserved bit. To provide compatibility with future products, the value of a reserved bit should be preserved across a read-modify-write operation.
28	S7DCOP	RW	0	Sample 7 Digital Comparator Operation Value Description 0 The eighth sample is saved in Sample Sequence FIFO0. 1 The eighth sample is sent to the digital comparator unit specified by the <i>S7DCSEL</i> bit in the ADCSSDC0 register, and the value is not written to the FIFO.
27:25	reserved	RO	0x0	Software should not rely on the value of a reserved bit. To provide compatibility with future products, the value of a reserved bit should be preserved across a read-modify-write operation.
24	S6DCOP	RW	0	Sample 6 Digital Comparator Operation Same definition as <i>S7DCOP</i> but used during the seventh sample.
23:21	reserved	RO	0x0	Software should not rely on the value of a reserved bit. To provide compatibility with future products, the value of a reserved bit should be preserved across a read-modify-write operation.
20	S5DCOP	RW	0	Sample 5 Digital Comparator Operation Same definition as <i>S7DCOP</i> but used during the sixth sample.
19:17	reserved	RO	0x0	Software should not rely on the value of a reserved bit. To provide compatibility with future products, the value of a reserved bit should be preserved across a read-modify-write operation.
16	S4DCOP	RW	0	Sample 4 Digital Comparator Operation Same definition as <i>S7DCOP</i> but used during the fifth sample.
15:13	reserved	RO	0x0	Software should not rely on the value of a reserved bit. To provide compatibility with future products, the value of a reserved bit should be preserved across a read-modify-write operation.

Bit/Field	Name	Type	Reset	Description
12	S3DCOP	RW	0	Sample 3 Digital Comparator Operation Same definition as S7DCOP but used during the fourth sample.
11:9	reserved	RO	0x0	Software should not rely on the value of a reserved bit. To provide compatibility with future products, the value of a reserved bit should be preserved across a read-modify-write operation.
8	S2DCOP	RW	0	Sample 2 Digital Comparator Operation Same definition as S7DCOP but used during the third sample.
7:5	reserved	RO	0x0	Software should not rely on the value of a reserved bit. To provide compatibility with future products, the value of a reserved bit should be preserved across a read-modify-write operation.
4	S1DCOP	RW	0	Sample 1 Digital Comparator Operation Same definition as S7DCOP but used during the second sample.
3:1	reserved	RO	0x0	Software should not rely on the value of a reserved bit. To provide compatibility with future products, the value of a reserved bit should be preserved across a read-modify-write operation.
0	S0DCOP	RW	0	Sample 0 Digital Comparator Operation Same definition as S7DCOP but used during the first sample.

Register 26: ADC Sample Sequence 0 Digital Comparator Select (ADCSSDC0), offset 0x054

This register determines which digital comparator receives the sample from the given conversion on Sample Sequence 0, if the corresponding S_nDCOP bit in the **ADCSSOP0** register is set.

ADC Sample Sequence 0 Digital Comparator Select (ADCSSDC0)

ADC0 base: 0x4003.8000
 ADC1 base: 0x4003.9000
 Offset 0x054
 Type RW, reset 0x0000.0000

	31	30	29	28	27	26	25	24	23	22	21	20	19	18	17	16
	S7DCSEL				S6DCSEL				S5DCSEL				S4DCSEL			
Type	RW	RW	RW	RW	RW	RW	RW	RW	RW	RW	RW	RW	RW	RW	RW	RW
Reset	0	0	0	0	0	0	0	0	0	0	0	0	0	0	0	0
	15	14	13	12	11	10	9	8	7	6	5	4	3	2	1	0
	S3DCSEL				S2DCSEL				S1DCSEL				S0DCSEL			
Type	RW	RW	RW	RW	RW	RW	RW	RW	RW	RW	RW	RW	RW	RW	RW	RW
Reset	0	0	0	0	0	0	0	0	0	0	0	0	0	0	0	0

Bit/Field	Name	Type	Reset	Description																		
31:28	S7DCSEL	RW	0x0	<p>Sample 7 Digital Comparator Select</p> <p>When the $S7DCOP$ bit in the ADCSSOP0 register is set, this field indicates which digital comparator unit (and its associated set of control registers) receives the eighth sample from Sample Sequencer 0.</p> <p>Note: Values not listed are reserved.</p> <table border="0"> <tr> <td>Value</td> <td>Description</td> </tr> <tr> <td>0x0</td> <td>Digital Comparator Unit 0 (ADCDCCMP0 and ADCDCCTL0)</td> </tr> <tr> <td>0x1</td> <td>Digital Comparator Unit 1 (ADCDCCMP1 and ADCDCCTL1)</td> </tr> <tr> <td>0x2</td> <td>Digital Comparator Unit 2 (ADCDCCMP2 and ADCDCCTL2)</td> </tr> <tr> <td>0x3</td> <td>Digital Comparator Unit 3 (ADCDCCMP3 and ADCDCCTL3)</td> </tr> <tr> <td>0x4</td> <td>Digital Comparator Unit 4 (ADCDCCMP4 and ADCDCCTL4)</td> </tr> <tr> <td>0x5</td> <td>Digital Comparator Unit 5 (ADCDCCMP5 and ADCDCCTL5)</td> </tr> <tr> <td>0x6</td> <td>Digital Comparator Unit 6 (ADCDCCMP6 and ADCDCCTL6)</td> </tr> <tr> <td>0x7</td> <td>Digital Comparator Unit 7 (ADCDCCMP7 and ADCDCCTL7)</td> </tr> </table>	Value	Description	0x0	Digital Comparator Unit 0 (ADCDCCMP0 and ADCDCCTL0)	0x1	Digital Comparator Unit 1 (ADCDCCMP1 and ADCDCCTL1)	0x2	Digital Comparator Unit 2 (ADCDCCMP2 and ADCDCCTL2)	0x3	Digital Comparator Unit 3 (ADCDCCMP3 and ADCDCCTL3)	0x4	Digital Comparator Unit 4 (ADCDCCMP4 and ADCDCCTL4)	0x5	Digital Comparator Unit 5 (ADCDCCMP5 and ADCDCCTL5)	0x6	Digital Comparator Unit 6 (ADCDCCMP6 and ADCDCCTL6)	0x7	Digital Comparator Unit 7 (ADCDCCMP7 and ADCDCCTL7)
Value	Description																					
0x0	Digital Comparator Unit 0 (ADCDCCMP0 and ADCDCCTL0)																					
0x1	Digital Comparator Unit 1 (ADCDCCMP1 and ADCDCCTL1)																					
0x2	Digital Comparator Unit 2 (ADCDCCMP2 and ADCDCCTL2)																					
0x3	Digital Comparator Unit 3 (ADCDCCMP3 and ADCDCCTL3)																					
0x4	Digital Comparator Unit 4 (ADCDCCMP4 and ADCDCCTL4)																					
0x5	Digital Comparator Unit 5 (ADCDCCMP5 and ADCDCCTL5)																					
0x6	Digital Comparator Unit 6 (ADCDCCMP6 and ADCDCCTL6)																					
0x7	Digital Comparator Unit 7 (ADCDCCMP7 and ADCDCCTL7)																					
27:24	S6DCSEL	RW	0x0	<p>Sample 6 Digital Comparator Select</p> <p>This field has the same encodings as $S7DCSEL$ but is used during the seventh sample.</p>																		
23:20	S5DCSEL	RW	0x0	<p>Sample 5 Digital Comparator Select</p> <p>This field has the same encodings as $S7DCSEL$ but is used during the sixth sample.</p>																		
19:16	S4DCSEL	RW	0x0	<p>Sample 4 Digital Comparator Select</p> <p>This field has the same encodings as $S7DCSEL$ but is used during the fifth sample.</p>																		
15:12	S3DCSEL	RW	0x0	<p>Sample 3 Digital Comparator Select</p> <p>This field has the same encodings as $S7DCSEL$ but is used during the fourth sample.</p>																		

Bit/Field	Name	Type	Reset	Description
11:8	S2DCSEL	RW	0x0	Sample 2 Digital Comparator Select This field has the same encodings as S7DCSEL but is used during the third sample.
7:4	S1DCSEL	RW	0x0	Sample 1 Digital Comparator Select This field has the same encodings as S7DCSEL but is used during the second sample.
3:0	S0DCSEL	RW	0x0	Sample 0 Digital Comparator Select This field has the same encodings as S7DCSEL but is used during the first sample.

Register 27: ADC Sample Sequence Extended Input Multiplexer Select 0 (ADCSSEMUX0), offset 0x058

This register, along with the **ADCSSMUX0** register, defines the analog input configuration for each sample in a sequence executed with Sample Sequencer 0. If a bit in this register is set, the corresponding **MUX_n** field in the **ADCSSMUX0** register selects from **AIN[19:16]**. When a bit in this register is clear, the corresponding **MUX_n** field selects from **AIN[15:0]**. This register is 32 bits wide and contains information for eight possible samples.

Note that this register is not used when the differential channel designation is used (the **D_n** bit is set in the **ADCSSCTL0** register) because the **ADCSSMUX0** register can select all the available pairs.

ADC Sample Sequence Extended Input Multiplexer Select 0 (ADCSSEMUX0)

ADC0 base: 0x4003.8000
 ADC1 base: 0x4003.9000
 Offset 0x058
 Type RW, reset 0x0000.0000

	31	30	29	28	27	26	25	24	23	22	21	20	19	18	17	16
	reserved			EMUX7	reserved			EMUX6	reserved			EMUX5	reserved			EMUX4
Type	RO	RO	RO	RW	RO	RO	RO	RW	RO	RO	RO	RW	RO	RO	RO	RW
Reset	0	0	0	0	0	0	0	0	0	0	0	0	0	0	0	0
	15	14	13	12	11	10	9	8	7	6	5	4	3	2	1	0
	reserved			EMUX3	reserved			EMUX2	reserved			EMUX1	reserved			EMUX0
Type	RO	RO	RO	RW	RO	RO	RO	RW	RO	RO	RO	RW	RO	RO	RO	RW
Reset	0	0	0	0	0	0	0	0	0	0	0	0	0	0	0	0

Bit/Field	Name	Type	Reset	Description
31:29	reserved	RO	0x0	Software should not rely on the value of a reserved bit. To provide compatibility with future products, the value of a reserved bit should be preserved across a read-modify-write operation.
28	EMUX7	RW	0x0	<p>8th Sample Input Select (Upper Bit)</p> <p>The EMUX7 field is used during the eighth sample of a sequence executed with the sample sequencer.</p> <p>Value Description</p> <p>0 The eighth sample input is selected from AIN[15:0] using the ADCSSMUX0 register. For example, if the MUX7 field is 0x0, AIN0 is selected.</p> <p>1 The eighth sample input is selected from AIN[19:16] using the ADCSSMUX0 register. For example, if the MUX7 field is 0x0, AIN16 is selected.</p>
27:25	reserved	RO	0x0	Software should not rely on the value of a reserved bit. To provide compatibility with future products, the value of a reserved bit should be preserved across a read-modify-write operation.
24	EMUX6	RW	0x0	<p>7th Sample Input Select (Upper Bit)</p> <p>The EMUX6 field is used during the seventh sample of a sequence executed with the sample sequencer. This bit has the same description as EMUX7.</p>
23:21	reserved	RO	0x0	Software should not rely on the value of a reserved bit. To provide compatibility with future products, the value of a reserved bit should be preserved across a read-modify-write operation.

Bit/Field	Name	Type	Reset	Description
20	EMUX5	RW	0x0	6th Sample Input Select (Upper Bit) The <code>EMUX5</code> field is used during the sixth sample of a sequence executed with the sample sequencer. This bit has the same description as <code>EMUX7</code> .
19:17	reserved	RO	0x0	Software should not rely on the value of a reserved bit. To provide compatibility with future products, the value of a reserved bit should be preserved across a read-modify-write operation.
16	EMUX4	RW	0x0	5th Sample Input Select (Upper Bit) The <code>EMUX4</code> field is used during the fifth sample of a sequence executed with the sample sequencer. This bit has the same description as <code>EMUX7</code> .
15:13	reserved	RO	0x0	Software should not rely on the value of a reserved bit. To provide compatibility with future products, the value of a reserved bit should be preserved across a read-modify-write operation.
12	EMUX3	RW	0x0	4th Sample Input Select (Upper Bit) The <code>EMUX3</code> field is used during the fourth sample of a sequence executed with the sample sequencer. This bit has the same description as <code>EMUX7</code> .
11:9	reserved	RO	0x0	Software should not rely on the value of a reserved bit. To provide compatibility with future products, the value of a reserved bit should be preserved across a read-modify-write operation.
8	EMUX2	RW	0x0	3rd Sample Input Select (Upper Bit) The <code>EMUX2</code> field is used during the third sample of a sequence executed with the sample sequencer. This bit has the same description as <code>EMUX7</code> .
7:5	reserved	RO	0x0	Software should not rely on the value of a reserved bit. To provide compatibility with future products, the value of a reserved bit should be preserved across a read-modify-write operation.
4	EMUX1	RW	0x0	2th Sample Input Select (Upper Bit) The <code>EMUX1</code> field is used during the second sample of a sequence executed with the sample sequencer. This bit has the same description as <code>EMUX7</code> .
3:1	reserved	RO	0x0	Software should not rely on the value of a reserved bit. To provide compatibility with future products, the value of a reserved bit should be preserved across a read-modify-write operation.
0	EMUX0	RW	0x0	1st Sample Input Select (Upper Bit) The <code>EMUX0</code> field is used during the first sample of a sequence executed with the sample sequencer. This bit has the same description as <code>EMUX7</code> .

Register 28: ADC Sample Sequence 0 Sample and Hold Time (ADCSSTSH0), offset 0x05C

This register controls the sample period size for each sample of sequencer 0. Each sample and hold period select specifies the time allocated to the sample and hold circuit as shown by the encodings in Table 18-3 on page 1182.

Note: If sampling the internal temperature sensor, the sample and hold width should be at least 16 ADC clocks ($T_{SHn} = 0x4$).

Table 18-8. Sample and Hold Width in ADC Clocks

TSHn Encoding	N _{SH}
0x0	4
0x1	reserved
0x2	8
0x3	reserved
0x4	16
0x5	reserved
0x6	32
0x7	reserved
0x8	64
0x9	reserved
0xA	128
0xB	reserved
0xC	256
0xD-0xF	reserved

ADC Sample Sequence 0 Sample and Hold Time (ADCSSTSH0)

ADC0 base: 0x4003.8000
 ADC1 base: 0x4003.9000
 Offset 0x05C
 Type RW, reset 0x0000.0000

	31	30	29	28	27	26	25	24	23	22	21	20	19	18	17	16
	TSH7				TSH6				TSH5				TSH4			
Type	RW	RW	RW	RW	RW	RW	RW	RW	RW	RW	RW	RW	RW	RW	RW	RW
Reset	0	0	0	0	0	0	0	0	0	0	0	0	0	0	0	0
	15	14	13	12	11	10	9	8	7	6	5	4	3	2	1	0
	TSH3				TSH2				TSH1				TSH0			
Type	RW	RW	RW	RW	RW	RW	RW	RW	RW	RW	RW	RW	RW	RW	RW	RW
Reset	0	0	0	0	0	0	0	0	0	0	0	0	0	0	0	0

Bit/Field	Name	Type	Reset	Description
31:28	TSH7	RW	0x0	8th Sample and Hold Period Select The TSH7 field is used during the eighth sample of a sequence executed with the sample sequencer.
27:24	TSH6	RW	0x0	7th Sample and Hold Period Select The TSH6 field is used during the seventh sample of a sequence executed with the sample sequencer.

Bit/Field	Name	Type	Reset	Description
23:20	TSH5	RW	0x0	6th Sample and Hold Period Select The TSH5 field is used during the sixth sample of a sequence executed with the sample sequencer.
19:16	TSH4	RW	0x0	5th Sample and Hold Period Select The TSH4 field is used during the fifth sample of a sequence executed with the sample sequencer.
15:12	TSH3	RW	0x0	4th Sample and Hold Period Select The TSH3 field is used during the fourth sample of a sequence executed with the sample sequencer.
11:8	TSH2	RW	0x0	3rd Sample and Hold Period Select The TSH2 field is used during the third sample of a sequence executed with the sample sequencer.
7:4	TSH1	RW	0x0	2nd Sample and Hold Period Select The TSH1 field is used during the second sample of a sequence executed with the sample sequencer.
3:0	TSH0	RW	0x0	1st Sample and Hold Period Select The TSH0 field is used during the first sample of a sequence executed with the sample sequencer.

Register 29: ADC Sample Sequence Input Multiplexer Select 1 (ADCSSMUX1), offset 0x060**Register 30: ADC Sample Sequence Input Multiplexer Select 2 (ADCSSMUX2), offset 0x080**

This register, along with the **ADCSEMUX1** or **ADCSEMUX2** register, defines the analog input configuration for each sample in a sequence executed with Sample Sequencer 1 or 2. If the corresponding **EMUX_n** bit in the **ADCSEMUX1** or **ADCSEMUX2** register is set, the **MUX_n** field in this register selects from **AIN[19:16]**. When the corresponding **EMUX_n** bit is clear, the **MUX_n** field selects from **AIN[15:0]**. These registers are 16 bits wide and contain information for four possible samples. See the **ADCSSMUX0** register on page 1233 for detailed bit descriptions. The **ADCSSMUX1** register affects Sample Sequencer 1 and the **ADCSSMUX2** register affects Sample Sequencer 2.

Note: Channels **AIN[31:20]** do not exist on this microcontroller. Configuring **MUX_n** to be 0xC-0xF when the corresponding **EMUX_n** bit is set results in undefined behavior.

ADC Sample Sequence Input Multiplexer Select n (ADCSSMUXn)

ADC0 base: 0x4003.8000

ADC1 base: 0x4003.9000

Offset 0x060

Type RW, reset 0x0000.0000

	31	30	29	28	27	26	25	24	23	22	21	20	19	18	17	16
	reserved															
Type	RO	RO	RO	RO	RO	RO	RO	RO	RO	RO	RO	RO	RO	RO	RO	RO
Reset	0	0	0	0	0	0	0	0	0	0	0	0	0	0	0	0
	15	14	13	12	11	10	9	8	7	6	5	4	3	2	1	0
	MUX3				MUX2				MUX1				MUX0			
Type	RW	RW	RW	RW	RW	RW	RW	RW	RW	RW	RW	RW	RW	RW	RW	RW
Reset	0	0	0	0	0	0	0	0	0	0	0	0	0	0	0	0

Bit/Field	Name	Type	Reset	Description
31:16	reserved	RO	0x0000	Software should not rely on the value of a reserved bit. To provide compatibility with future products, the value of a reserved bit should be preserved across a read-modify-write operation.
15:12	MUX3	RW	0x0	4th Sample Input Select
11:8	MUX2	RW	0x0	3rd Sample Input Select
7:4	MUX1	RW	0x0	2nd Sample Input Select
3:0	MUX0	RW	0x0	1st Sample Input Select

Register 31: ADC Sample Sequence Control 1 (ADCSSCTL1), offset 0x064

Register 32: ADC Sample Sequence Control 2 (ADCSSCTL2), offset 0x084

These registers contain the configuration information for each sample for a sequence executed with Sample Sequencer 1 or 2. When configuring a sample sequence, the **END** bit must be set for the final sample, whether it be after the first sample, fourth sample, or any sample in between. These registers are 16-bits wide and contain information for four possible samples. See the **ADCSSCTL0** register on page 1235 for detailed bit descriptions. The **ADCSSCTL1** register configures Sample Sequencer 1 and the **ADCSSCTL2** register configures Sample Sequencer 2.

ADC Sample Sequence Control n (ADCSSCTLn)

ADC0 base: 0x4003.8000
 ADC1 base: 0x4003.9000
 Offset 0x064
 Type RW, reset 0x0000.0000

	31	30	29	28	27	26	25	24	23	22	21	20	19	18	17	16
	reserved															
Type	RO	RO	RO	RO	RO	RO	RO	RO	RO	RO	RO	RO	RO	RO	RO	RO
Reset	0	0	0	0	0	0	0	0	0	0	0	0	0	0	0	0
	15	14	13	12	11	10	9	8	7	6	5	4	3	2	1	0
	TS3	IE3	END3	D3	TS2	IE2	END2	D2	TS1	IE1	END1	D1	TS0	IE0	END0	D0
Type	RW	RW	RW	RW	RW	RW	RW	RW	RW	RW	RW	RW	RW	RW	RW	RW
Reset	0	0	0	0	0	0	0	0	0	0	0	0	0	0	0	0

Bit/Field	Name	Type	Reset	Description
31:16	reserved	RO	0x0000	Software should not rely on the value of a reserved bit. To provide compatibility with future products, the value of a reserved bit should be preserved across a read-modify-write operation.
15	TS3	RW	0	4th Sample Temp Sensor Select Value Description 0 The input pin specified by the ADCSSMUXn register is read during the fourth sample of the sample sequence. 1 The temperature sensor is read during the fourth sample of the sample sequence.
14	IE3	RW	0	4th Sample Interrupt Enable Value Description 0 The raw interrupt is not asserted to the interrupt controller. 1 The raw interrupt signal (INR0 bit) is asserted at the end of the fourth sample's conversion. If the MASK0 bit in the ADCIM register is set, the interrupt is promoted to the interrupt controller. It is legal to have multiple samples within a sequence generate interrupts.

Bit/Field	Name	Type	Reset	Description
13	END3	RW	0	<p>4th Sample is End of Sequence</p> <p>Value Description</p> <p>0 Another sample in the sequence is the final sample.</p> <p>1 The fourth sample is the last sample of the sequence.</p> <p>It is possible to end the sequence on any sample position. Software must set an <code>END_n</code> bit somewhere within the sequence. Samples defined after the sample containing a set <code>END_n</code> bit are not requested for conversion even though the fields may be non-zero.</p>
12	D3	RW	0	<p>4th Sample Differential Input Select</p> <p>Value Description</p> <p>0 The analog inputs are not differentially sampled.</p> <p>1 The analog input is differentially sampled. The corresponding ADCSSMUX_n nibble must be set to the pair number "i", where the paired inputs are "2i and 2i+1".</p> <p>Because the temperature sensor does not have a differential option, this bit must not be set when the <code>TS3</code> bit is set.</p>
11	TS2	RW	0	<p>3rd Sample Temp Sensor Select</p> <p>Value Description</p> <p>0 The input pin specified by the ADCSSMUX_n register is read during the third sample of the sample sequence.</p> <p>1 The temperature sensor is read during the third sample of the sample sequence.</p>
10	IE2	RW	0	<p>3rd Sample Interrupt Enable</p> <p>Value Description</p> <p>0 The raw interrupt is not asserted to the interrupt controller.</p> <p>1 The raw interrupt signal (<code>INR0</code> bit) is asserted at the end of the third sample's conversion. If the <code>MASK0</code> bit in the ADCIM register is set, the interrupt is promoted to the interrupt controller.</p> <p>It is legal to have multiple samples within a sequence generate interrupts.</p>
9	END2	RW	0	<p>3rd Sample is End of Sequence</p> <p>Value Description</p> <p>0 Another sample in the sequence is the final sample.</p> <p>1 The third sample is the last sample of the sequence.</p> <p>It is possible to end the sequence on any sample position. Software must set an <code>END_n</code> bit somewhere within the sequence. Samples defined after the sample containing a set <code>END_n</code> bit are not requested for conversion even though the fields may be non-zero.</p>

Bit/Field	Name	Type	Reset	Description
8	D2	RW	0	<p>3rd Sample Differential Input Select</p> <p>Value Description</p> <p>0 The analog inputs are not differentially sampled.</p> <p>1 The analog input is differentially sampled. The corresponding ADCSSMUXn nibble must be set to the pair number "i", where the paired inputs are "2i and 2i+1".</p> <p>Because the temperature sensor does not have a differential option, this bit must not be set when the TS2 bit is set.</p>
7	TS1	RW	0	<p>2nd Sample Temp Sensor Select</p> <p>Value Description</p> <p>0 The input pin specified by the ADCSSMUXn register is read during the second sample of the sample sequence.</p> <p>1 The temperature sensor is read during the second sample of the sample sequence.</p>
6	IE1	RW	0	<p>2nd Sample Interrupt Enable</p> <p>Value Description</p> <p>0 The raw interrupt is not asserted to the interrupt controller.</p> <p>1 The raw interrupt signal (INR0 bit) is asserted at the end of the second sample's conversion. If the MASK0 bit in the ADCIM register is set, the interrupt is promoted to the interrupt controller.</p> <p>It is legal to have multiple samples within a sequence generate interrupts.</p>
5	END1	RW	0	<p>2nd Sample is End of Sequence</p> <p>Value Description</p> <p>0 Another sample in the sequence is the final sample.</p> <p>1 The second sample is the last sample of the sequence.</p> <p>It is possible to end the sequence on any sample position. Software must set an ENDn bit somewhere within the sequence. Samples defined after the sample containing a set ENDn bit are not requested for conversion even though the fields may be non-zero.</p>
4	D1	RW	0	<p>2nd Sample Differential Input Select</p> <p>Value Description</p> <p>0 The analog inputs are not differentially sampled.</p> <p>1 The analog input is differentially sampled. The corresponding ADCSSMUXn nibble must be set to the pair number "i", where the paired inputs are "2i and 2i+1".</p> <p>Because the temperature sensor does not have a differential option, this bit must not be set when the TS1 bit is set.</p>

Bit/Field	Name	Type	Reset	Description
3	TS0	RW	0	<p>1st Sample Temp Sensor Select</p> <p>Value Description</p> <p>0 The input pin specified by the ADCSSMUXn register is read during the first sample of the sample sequence.</p> <p>1 The temperature sensor is read during the first sample of the sample sequence.</p>
2	IE0	RW	0	<p>1st Sample Interrupt Enable</p> <p>Value Description</p> <p>0 The raw interrupt is not asserted to the interrupt controller.</p> <p>1 The raw interrupt signal (INR0 bit) is asserted at the end of the first sample's conversion. If the MASK0 bit in the ADCIM register is set, the interrupt is promoted to the interrupt controller.</p> <p>It is legal to have multiple samples within a sequence generate interrupts.</p>
1	END0	RW	0	<p>1st Sample is End of Sequence</p> <p>Value Description</p> <p>0 Another sample in the sequence is the final sample.</p> <p>1 The first sample is the last sample of the sequence.</p> <p>It is possible to end the sequence on any sample position. Software must set an ENDn bit somewhere within the sequence. Samples defined after the sample containing a set ENDn bit are not requested for conversion even though the fields may be non-zero.</p>
0	D0	RW	0	<p>1st Sample Differential Input Select</p> <p>Value Description</p> <p>0 The analog inputs are not differentially sampled.</p> <p>1 The analog input is differentially sampled. The corresponding ADCSSMUXn nibble must be set to the pair number "i", where the paired inputs are "2i and 2i+1".</p> <p>Because the temperature sensor does not have a differential option, this bit must not be set when the TS0 bit is set.</p>

Register 33: ADC Sample Sequence 1 Operation (ADCSSOP1), offset 0x070

Register 34: ADC Sample Sequence 2 Operation (ADCSSOP2), offset 0x090

This register determines whether the sample from the given conversion on Sample Sequence n is saved in the Sample Sequence n FIFO or sent to the digital comparator unit. The **ADCSSOP1** register controls Sample Sequencer 1 and the **ADCSSOP2** register controls Sample Sequencer 2.

ADC Sample Sequence n Operation (ADCSSOPn)

ADC0 base: 0x4003.8000
 ADC1 base: 0x4003.9000
 Offset 0x070
 Type RW, reset 0x0000.0000



Bit/Field	Name	Type	Reset	Description
31:13	reserved	RO	0x0000.0	Software should not rely on the value of a reserved bit. To provide compatibility with future products, the value of a reserved bit should be preserved across a read-modify-write operation.
12	S3DCOP	RW	0	Sample 3 Digital Comparator Operation Value Description 0 The fourth sample is saved in Sample Sequence FIFO. 1 The fourth sample is sent to the digital comparator unit specified by the S3DCSEL bit in the ADCSSDC0n register, and the value is not written to the FIFO.
11:9	reserved	RO	0x0	Software should not rely on the value of a reserved bit. To provide compatibility with future products, the value of a reserved bit should be preserved across a read-modify-write operation.
8	S2DCOP	RW	0	Sample 2 Digital Comparator Operation Same definition as S3DCOP but used during the third sample.
7:5	reserved	RO	0x0	Software should not rely on the value of a reserved bit. To provide compatibility with future products, the value of a reserved bit should be preserved across a read-modify-write operation.
4	S1DCOP	RW	0	Sample 1 Digital Comparator Operation Same definition as S3DCOP but used during the second sample.
3:1	reserved	RO	0x0	Software should not rely on the value of a reserved bit. To provide compatibility with future products, the value of a reserved bit should be preserved across a read-modify-write operation.
0	S0DCOP	RW	0	Sample 0 Digital Comparator Operation Same definition as S3DCOP but used during the first sample.

Register 35: ADC Sample Sequence 1 Digital Comparator Select (ADCSSDC1), offset 0x074**Register 36: ADC Sample Sequence 2 Digital Comparator Select (ADCSSDC2), offset 0x094**

These registers determine which digital comparator receives the sample from the given conversion on Sample Sequence n if the corresponding S_nDCOP bit in the **ADCSSOPn** register is set. The **ADCSSDC1** register controls the selection for Sample Sequencer 1 and the **ADCSSDC2** register controls the selection for Sample Sequencer 2.

ADC Sample Sequence n Digital Comparator Select (ADCSSDCn)

ADC0 base: 0x4003.8000
 ADC1 base: 0x4003.9000
 Offset 0x074
 Type RW, reset 0x0000.0000

	31	30	29	28	27	26	25	24	23	22	21	20	19	18	17	16
	reserved															
Type	RO	RO	RO	RO	RO	RO	RO	RO	RO	RO	RO	RO	RO	RO	RO	RO
Reset	0	0	0	0	0	0	0	0	0	0	0	0	0	0	0	0
	15	14	13	12	11	10	9	8	7	6	5	4	3	2	1	0
	S3DCSEL				S2DCSEL				S1DCSEL				S0DCSEL			
Type	RW	RW	RW	RW	RW	RW	RW	RW	RW	RW	RW	RW	RW	RW	RW	RW
Reset	0	0	0	0	0	0	0	0	0	0	0	0	0	0	0	0

Bit/Field	Name	Type	Reset	Description																		
31:16	reserved	RO	0x0000	Software should not rely on the value of a reserved bit. To provide compatibility with future products, the value of a reserved bit should be preserved across a read-modify-write operation.																		
15:12	S3DCSEL	RW	0x0	<p>Sample 3 Digital Comparator Select</p> <p>When the $S3DCOP$ bit in the ADCSSOPn register is set, this field indicates which digital comparator unit (and its associated set of control registers) receives the eighth sample from Sample Sequencer n.</p> <p>Note: Values not listed are reserved.</p> <table border="1"> <thead> <tr> <th>Value</th> <th>Description</th> </tr> </thead> <tbody> <tr><td>0x0</td><td>Digital Comparator Unit 0 (ADCDCOMP0 and ADCCCTL0)</td></tr> <tr><td>0x1</td><td>Digital Comparator Unit 1 (ADCDCOMP1 and ADCCCTL1)</td></tr> <tr><td>0x2</td><td>Digital Comparator Unit 2 (ADCDCOMP2 and ADCCCTL2)</td></tr> <tr><td>0x3</td><td>Digital Comparator Unit 3 (ADCDCOMP3 and ADCCCTL3)</td></tr> <tr><td>0x4</td><td>Digital Comparator Unit 4 (ADCDCOMP4 and ADCCCTL4)</td></tr> <tr><td>0x5</td><td>Digital Comparator Unit 5 (ADCDCOMP5 and ADCCCTL5)</td></tr> <tr><td>0x6</td><td>Digital Comparator Unit 6 (ADCDCOMP6 and ADCCCTL6)</td></tr> <tr><td>0x7</td><td>Digital Comparator Unit 7 (ADCDCOMP7 and ADCCCTL7)</td></tr> </tbody> </table>	Value	Description	0x0	Digital Comparator Unit 0 (ADCDCOMP0 and ADCCCTL0)	0x1	Digital Comparator Unit 1 (ADCDCOMP1 and ADCCCTL1)	0x2	Digital Comparator Unit 2 (ADCDCOMP2 and ADCCCTL2)	0x3	Digital Comparator Unit 3 (ADCDCOMP3 and ADCCCTL3)	0x4	Digital Comparator Unit 4 (ADCDCOMP4 and ADCCCTL4)	0x5	Digital Comparator Unit 5 (ADCDCOMP5 and ADCCCTL5)	0x6	Digital Comparator Unit 6 (ADCDCOMP6 and ADCCCTL6)	0x7	Digital Comparator Unit 7 (ADCDCOMP7 and ADCCCTL7)
Value	Description																					
0x0	Digital Comparator Unit 0 (ADCDCOMP0 and ADCCCTL0)																					
0x1	Digital Comparator Unit 1 (ADCDCOMP1 and ADCCCTL1)																					
0x2	Digital Comparator Unit 2 (ADCDCOMP2 and ADCCCTL2)																					
0x3	Digital Comparator Unit 3 (ADCDCOMP3 and ADCCCTL3)																					
0x4	Digital Comparator Unit 4 (ADCDCOMP4 and ADCCCTL4)																					
0x5	Digital Comparator Unit 5 (ADCDCOMP5 and ADCCCTL5)																					
0x6	Digital Comparator Unit 6 (ADCDCOMP6 and ADCCCTL6)																					
0x7	Digital Comparator Unit 7 (ADCDCOMP7 and ADCCCTL7)																					
11:8	S2DCSEL	RW	0x0	<p>Sample 2 Digital Comparator Select</p> <p>This field has the same encodings as S3DCSEL but is used during the third sample.</p>																		

Bit/Field	Name	Type	Reset	Description
7:4	S1DCSEL	RW	0x0	Sample 1 Digital Comparator Select This field has the same encodings as S3DCSEL but is used during the second sample.
3:0	S0DCSEL	RW	0x0	Sample 0 Digital Comparator Select This field has the same encodings as S3DCSEL but is used during the first sample.

Register 37: ADC Sample Sequence Extended Input Multiplexer Select 1 (ADCSEMUX1), offset 0x078

Register 38: ADC Sample Sequence Extended Input Multiplexer Select 2 (ADCSEMUX2), offset 0x098

This register, along with the **ADCSSMUX1** or **ADCSSMUX2** register, defines the analog input configuration for each sample in a sequence executed with either Sample Sequencer 1 or 2. If a bit in this register is set, the corresponding **MUX_n** field in the **ADCSSMUX1** or **ADCSSMUX2** register selects from **AIN[19:16]**. When a bit in this register is clear, the corresponding **MUX_n** field selects from **AIN[15:0]**. This register is 16 bits wide and contains information for four possible samples. The **ADCSEMUX1** register controls Sample Sequencer 1 and the **ADCSEMUX2** register controls Sample Sequencer 2.

Note that this register is not used when the differential channel designation is used (the **D_n** bit is set in the **ADCSSCTL1** or **ADCSSCTL2** register) because the **ADCSSMUX1** or **ADCSSMUX2** register can select all the available pairs.

ADC Sample Sequence Extended Input Multiplexer Select n (ADCSEMUXn)

ADC0 base: 0x4003.8000
 ADC1 base: 0x4003.9000
 Offset 0x078
 Type RW, reset 0x0000.0000

	31	30	29	28	27	26	25	24	23	22	21	20	19	18	17	16
	reserved															
Type	RO	RO	RO	RO	RO	RO	RO	RO	RO	RO	RO	RO	RO	RO	RO	RO
Reset	0	0	0	0	0	0	0	0	0	0	0	0	0	0	0	0
	15	14	13	12	11	10	9	8	7	6	5	4	3	2	1	0
	reserved			EMUX3	reserved				EMUX2	reserved			EMUX1	reserved		EMUX0
Type	RO	RO	RO	RW	RO	RO	RO	RW	RO	RO	RO	RW	RO	RO	RO	RW
Reset	0	0	0	0	0	0	0	0	0	0	0	0	0	0	0	0

Bit/Field	Name	Type	Reset	Description
31:13	reserved	RO	0x0000	Software should not rely on the value of a reserved bit. To provide compatibility with future products, the value of a reserved bit should be preserved across a read-modify-write operation.
12	EMUX3	RW	0x0	4th Sample Input Select (Upper Bit) The EMUX3 field is used during the fourth sample of a sequence executed with the sample sequencer. Value Description 0 The fourth sample input is selected from AIN[15:0] using the ADCSSMUX1 or ADCSSMUX2 register. For example, if the MUX3 field is 0x0, AIN0 is selected. 1 The fourth sample input is selected from AIN[19:16] using the ADCSSMUX1 or ADCSSMUX2 register. For example, if the MUX3 field is 0x0, AIN16 is selected.
11:9	reserved	RO	0x0	Software should not rely on the value of a reserved bit. To provide compatibility with future products, the value of a reserved bit should be preserved across a read-modify-write operation.

Bit/Field	Name	Type	Reset	Description
8	EMUX2	RW	0x0	3rd Sample Input Select (Upper Bit) The EMUX2 field is used during the third sample of a sequence executed with the sample sequencer. This bit has the same description as EMUX3.
7:5	reserved	RO	0x0	Software should not rely on the value of a reserved bit. To provide compatibility with future products, the value of a reserved bit should be preserved across a read-modify-write operation.
4	EMUX1	RW	0x0	2th Sample Input Select (Upper Bit) The EMUX1 field is used during the second sample of a sequence executed with the sample sequencer. This bit has the same description as EMUX3.
3:1	reserved	RO	0x0	Software should not rely on the value of a reserved bit. To provide compatibility with future products, the value of a reserved bit should be preserved across a read-modify-write operation.
0	EMUX0	RW	0x0	1st Sample Input Select (Upper Bit) The EMUX0 field is used during the first sample of a sequence executed with the sample sequencer. This bit has the same description as EMUX3.

Register 39: ADC Sample Sequence 1 Sample and Hold Time (ADCSSTSH1), offset 0x07C**Register 40: ADC Sample Sequence 2 Sample and Hold Time (ADCSSTSH2), offset 0x09C**

These registers control the sample period size for each sample step of sequencer 1 and sequencer 2. Each sample and hold period select specifies the time allocated to the sample and hold circuit as shown by the encodings in Table 18-3 on page 1182.

Note: If sampling the internal temperature sensor, the sample and hold width should be at least 16 ADC clocks ($T_{SHn} = 0x4$).

Table 18-9. Sample and Hold Width in ADC Clocks

TSHn Encoding	N _{SH}
0x0	4
0x1	reserved
0x2	8
0x3	reserved
0x4	16
0x5	reserved
0x6	32
0x7	reserved
0x8	64
0x9	reserved
0xA	128
0xB	reserved
0xC	256
0xD-0xF	reserved

ADC Sample Sequence n Sample and Hold Time (ADCSSTSHn)

ADC0 base: 0x4003.8000

ADC1 base: 0x4003.9000

Offset 0x07C

Type RW, reset 0x0000.0000

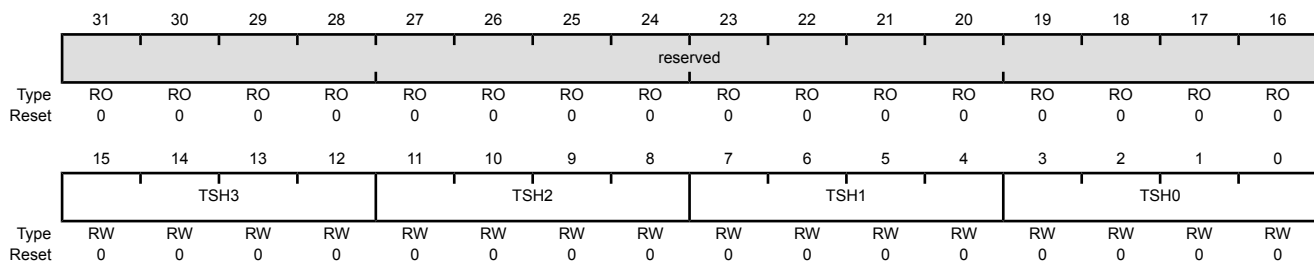

Bit/Field	Name	Type	Reset	Description
31:16	reserved	RO	0x0000	Software should not rely on the value of a reserved bit. To provide compatibility with future products, the value of a reserved bit should be preserved across a read-modify-write operation.

Bit/Field	Name	Type	Reset	Description
15:12	TSH3	RW	0x0	4th Sample and Hold Period Select The TSH3 field is used during the fourth sample of a sequence executed with the sample sequencer.
11:8	TSH2	RW	0x0	3rd Sample and Hold Period Select The TSH2 field is used during the third sample of a sequence executed with the sample sequencer.
7:4	TSH1	RW	0x0	2nd Sample and Hold Period Select The TSH1 field is used during the second sample of a sequence executed with the sample sequencer.
3:0	TSH0	RW	0x0	1st Sample and Hold Period Select The TSH0 field is used during the first sample of a sequence executed with the sample sequencer.

Register 41: ADC Sample Sequence Input Multiplexer Select 3 (ADCSSMUX3), offset 0x0A0

This register, along with the **ADCSEMUX3** register, defines the analog input configuration for the sample in a sequence executed with Sample Sequencer 3. If the **EMUX0** bit in the **ADCSEMUX3** register is set, the **MUX0** field in this register selects from **AIN[19:16]**. When the **EMUX0** bit is clear, the **MUX0** field selects from **AIN[15:0]**. This register is four bits wide and contains information for one possible sample. See the **ADCSSMUX0** register on page 1233 for detailed bit descriptions.

ADC Sample Sequence Input Multiplexer Select 3 (ADCSSMUX3)

ADC0 base: 0x4003.8000
 ADC1 base: 0x4003.9000
 Offset 0x0A0
 Type RW, reset 0x0000.0000

	31	30	29	28	27	26	25	24	23	22	21	20	19	18	17	16
	reserved															
Type	RO	RO	RO	RO	RO	RO	RO	RO	RO	RO	RO	RO	RO	RO	RO	RO
Reset	0	0	0	0	0	0	0	0	0	0	0	0	0	0	0	0
	15	14	13	12	11	10	9	8	7	6	5	4	3	2	1	0
	reserved												MUX0			
Type	RO	RO	RO	RO	RO	RO	RO	RO	RO	RO	RO	RO	RW	RW	RW	RW
Reset	0	0	0	0	0	0	0	0	0	0	0	0	0	0	0	0

Bit/Field	Name	Type	Reset	Description
31:4	reserved	RO	0x0000.000	Software should not rely on the value of a reserved bit. To provide compatibility with future products, the value of a reserved bit should be preserved across a read-modify-write operation.
3:0	MUX0	RW	0	1st Sample Input Select

Register 42: ADC Sample Sequence Control 3 (ADCSSCTL3), offset 0x0A4

This register contains the configuration information for a sample executed with Sample Sequencer 3. This register is 4 bits wide and contains information for one possible sample. See the **ADCSSCTL0** register on page 1235 for detailed bit descriptions.

Note: When configuring a sample sequence in this register, the **END0** bit must be set.

ADC Sample Sequence Control 3 (ADCSSCTL3)

ADC0 base: 0x4003.8000
 ADC1 base: 0x4003.9000
 Offset 0x0A4
 Type RW, reset 0x0000.0000

	31	30	29	28	27	26	25	24	23	22	21	20	19	18	17	16	
	reserved																
Type	RO	RO	RO	RO	RO	RO	RO	RO	RO	RO	RO	RO	RO	RO	RO	RO	
Reset	0	0	0	0	0	0	0	0	0	0	0	0	0	0	0	0	
	15	14	13	12	11	10	9	8	7	6	5	4	3	2	1	0	
	reserved													TS0	IE0	END0	D0
Type	RO	RO	RO	RO	RO	RO	RO	RO	RO	RO	RO	RO	RO	RW	RW	RW	RW
Reset	0	0	0	0	0	0	0	0	0	0	0	0	0	0	0	0	0

Bit/Field	Name	Type	Reset	Description
31:4	reserved	RO	0x0000.000	Software should not rely on the value of a reserved bit. To provide compatibility with future products, the value of a reserved bit should be preserved across a read-modify-write operation.
3	TS0	RW	0	1st Sample Temp Sensor Select Value Description 0 The input pin specified by the ADCSSMUXn register is read during the first sample of the sample sequence. 1 The temperature sensor is read during the first sample of the sample sequence.
2	IE0	RW	0	Sample Interrupt Enable Value Description 0 The raw interrupt is not asserted to the interrupt controller. 1 The raw interrupt signal (INR0 bit) is asserted at the end of this sample's conversion. If the MASK0 bit in the ADCIM register is set, the interrupt is promoted to the interrupt controller. It is legal to have multiple samples within a sequence generate interrupts.
1	END0	RW	0	End of Sequence This bit must be set before initiating a single sample sequence. Value Description 0 Sampling and conversion continues. 1 This is the end of sequence.

Bit/Field	Name	Type	Reset	Description
0	D0	RW	0	Sample Differential Input Select
				Value Description
				0 The analog inputs are not differentially sampled.
				1 The analog input is differentially sampled. The corresponding ADCSSMUXn nibble must be set to the pair number "i", where the paired inputs are "2i and 2i+1".
				Because the temperature sensor does not have a differential option, this bit must not be set when the TS0 bit is set.

Register 43: ADC Sample Sequence 3 Operation (ADCSSOP3), offset 0x0B0

This register determines whether the sample from the given conversion on Sample Sequence 3 is saved in the Sample Sequence 3 FIFO or sent to the digital comparator unit.

ADC Sample Sequence 3 Operation (ADCSSOP3)

ADC0 base: 0x4003.8000
 ADC1 base: 0x4003.9000
 Offset 0x0B0
 Type RW, reset 0x0000.0000

	31	30	29	28	27	26	25	24	23	22	21	20	19	18	17	16
	reserved															
Type	RO	RO	RO	RO	RO	RO	RO	RO	RO	RO	RO	RO	RO	RO	RO	RO
Reset	0	0	0	0	0	0	0	0	0	0	0	0	0	0	0	0
	15	14	13	12	11	10	9	8	7	6	5	4	3	2	1	0
	reserved															S0DCOP
Type	RO	RO	RO	RO	RO	RO	RO	RO	RO	RO	RO	RO	RO	RO	RO	RW
Reset	0	0	0	0	0	0	0	0	0	0	0	0	0	0	0	0

Bit/Field	Name	Type	Reset	Description
31:1	reserved	RO	0x0000.000	Software should not rely on the value of a reserved bit. To provide compatibility with future products, the value of a reserved bit should be preserved across a read-modify-write operation.
0	S0DCOP	RW	0	Sample 0 Digital Comparator Operation
Value Description				
0	The sample is saved in Sample Sequence FIFO3.			
1	The sample is sent to the digital comparator unit specified by the S0DCSEL bit in the ADCSSDC03 register, and the value is not written to the FIFO.			

Register 44: ADC Sample Sequence 3 Digital Comparator Select (ADCSSDC3), offset 0x0B4

This register determines which digital comparator receives the sample from the given conversion on Sample Sequence 3 if the corresponding S_nDCOP bit in the **ADCSSOP3** register is set.

ADC Sample Sequence 3 Digital Comparator Select (ADCSSDC3)

ADC0 base: 0x4003.8000
 ADC1 base: 0x4003.9000
 Offset 0x0B4
 Type RW, reset 0x0000.0000

	31	30	29	28	27	26	25	24	23	22	21	20	19	18	17	16
	reserved															
Type	RO	RO	RO	RO	RO	RO	RO	RO	RO	RO	RO	RO	RO	RO	RO	RO
Reset	0	0	0	0	0	0	0	0	0	0	0	0	0	0	0	0
	15	14	13	12	11	10	9	8	7	6	5	4	3	2	1	0
	reserved												S0DCSEL			
Type	RO	RO	RO	RO	RO	RO	RO	RO	RO	RO	RO	RO	RW	RW	RW	RW
Reset	0	0	0	0	0	0	0	0	0	0	0	0	0	0	0	0

Bit/Field	Name	Type	Reset	Description
31:4	reserved	RO	0x0000.000	Software should not rely on the value of a reserved bit. To provide compatibility with future products, the value of a reserved bit should be preserved across a read-modify-write operation.
3:0	S0DCSEL	RW	0x0	Sample 0 Digital Comparator Select When the $S0DCOP$ bit in the ADCSSOP3 register is set, this field indicates which digital comparator unit (and its associated set of control registers) receives the sample from Sample Sequencer 3.

Note: Values not listed are reserved.

Value	Description
0x0	Digital Comparator Unit 0 (ADCDCOMP0 and ADCCCTL0)
0x1	Digital Comparator Unit 1 (ADCDCOMP1 and ADCCCTL1)
0x2	Digital Comparator Unit 2 (ADCDCOMP2 and ADCCCTL2)
0x3	Digital Comparator Unit 3 (ADCDCOMP3 and ADCCCTL3)
0x4	Digital Comparator Unit 4 (ADCDCOMP4 and ADCCCTL4)
0x5	Digital Comparator Unit 5 (ADCDCOMP5 and ADCCCTL5)
0x6	Digital Comparator Unit 6 (ADCDCOMP6 and ADCCCTL6)
0x7	Digital Comparator Unit 7 (ADCDCOMP7 and ADCCCTL7)

Register 45: ADC Sample Sequence Extended Input Multiplexer Select 3 (ADCSEMUX3), offset 0x0B8

This register, along with the **ADCSSMUX3** register, defines the analog input configuration for the sample in a sequence executed with Sample Sequencer 3. If **EMUX0** is set, the **MUX0** field in the **ADCSSMUX3** register selects from **AIN[19:16]**. When **EMUX0** is clear, the **MUX0** field selects from **AIN[15:0]**. This register is 1 bit wide and contains information for one possible sample.

Note that this register is not used when the differential channel designation is used (the **Dn** bit is set in the **ADCSSCTL3** register) because the **ADCSSMUX3** register can select all the available pairs.

ADC Sample Sequence Extended Input Multiplexer Select 3 (ADCSEMUX3)

ADC0 base: 0x4003.8000
 ADC1 base: 0x4003.9000
 Offset 0x0B8
 Type RW, reset 0x0000.0000

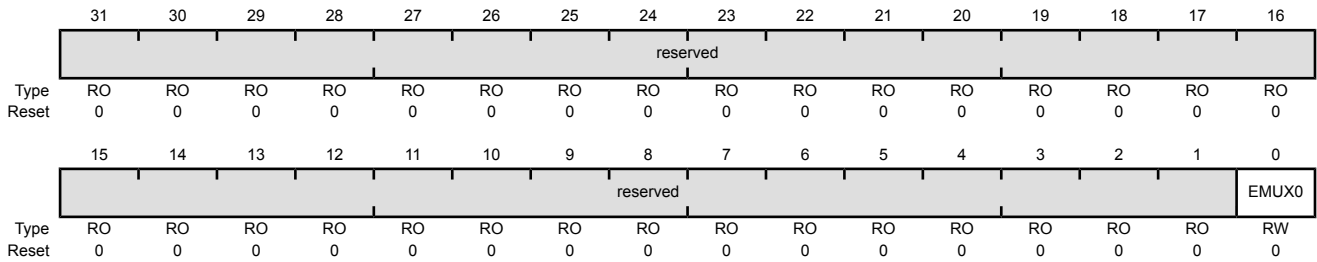

Bit/Field	Name	Type	Reset	Description
31:1	reserved	RO	0x0000.000	Software should not rely on the value of a reserved bit. To provide compatibility with future products, the value of a reserved bit should be preserved across a read-modify-write operation.
0	EMUX0	RW	0x0	1st Sample Input Select (Upper Bit) The EMUX0 field is used during the only sample of a sequence executed with the sample sequencer.
				Value Description
				0 The sample input is selected from AIN[15:0] using the ADCSSMUX3 register. For example, if the MUX0 field is 0x0, AIN0 is selected.
				1 The sample input is selected from AIN[19:16] using the ADCSSMUX3 register. For example, if the MUX0 field is 0x0, AIN16 is selected.

Register 46: ADC Sample Sequence 3 Sample and Hold Time (ADCSSTSH3), offset 0x0BC

This register controls the sample period size for the sample in sequencer 3. The sample and hold period select specifies the time allocated to the sample and hold circuit as shown by the encodings in Table 18-3 on page 1182

Note: If sampling the internal temperature sensor, the sample and hold width should be at least 16 ADC clocks ($T_{SHn} = 0x4$).

Table 18-10. Sample and Hold Width in ADC Clocks

TSHn Encoding	N _{SH}
0x0	4
0x1	reserved
0x2	8
0x3	reserved
0x4	16
0x5	reserved
0x6	32
0x7	reserved
0x8	64
0x9	reserved
0xA	128
0xB	reserved
0xC	256
0xD-0xF	reserved

ADC Sample Sequence 3 Sample and Hold Time (ADCSSTSH3)

ADC0 base: 0x4003.8000
 ADC1 base: 0x4003.9000
 Offset 0x0BC
 Type RW, reset 0x0000.0000

	31	30	29	28	27	26	25	24	23	22	21	20	19	18	17	16
	reserved															
Type	RO	RO	RO	RO	RO	RO	RO	RO	RO	RO	RO	RO	RO	RO	RO	RO
Reset	0	0	0	0	0	0	0	0	0	0	0	0	0	0	0	0
	15	14	13	12	11	10	9	8	7	6	5	4	3	2	1	0
	reserved												TSH0			
Type	RO	RO	RO	RO	RO	RO	RO	RO	RO	RO	RO	RO	RW	RW	RW	RW
Reset	0	0	0	0	0	0	0	0	0	0	0	0	0	0	0	0

Bit/Field	Name	Type	Reset	Description
31:4	reserved	RO	0x0	Software should not rely on the value of a reserved bit. To provide compatibility with future products, the value of a reserved bit should be preserved across a read-modify-write operation.
3:0	TSH0	RW	0x0	1st Sample and Hold Period Select The TSH0 field is used during the first sample of a sequence executed with the sample sequencer.

Register 47: ADC Digital Comparator Reset Initial Conditions (ADCDCRIC), offset 0xD00

This register provides the ability to reset any of the digital comparator interrupt or trigger functions back to their initial conditions. Resetting these functions ensures that the data that is being used by the interrupt and trigger functions in the digital comparator unit is not stale.

ADC Digital Comparator Reset Initial Conditions (ADCDCRIC)

ADC0 base: 0x4003.8000
 ADC1 base: 0x4003.9000
 Offset 0xD00
 Type WO, reset 0x0000.0000

	31	30	29	28	27	26	25	24	23	22	21	20	19	18	17	16
	reserved								DCTRIG7	DCTRIG6	DCTRIG5	DCTRIG4	DCTRIG3	DCTRIG2	DCTRIG1	DCTRIG0
Type	RO	RO	RO	RO	RO	RO	RO	RO	WO	WO	WO	WO	WO	WO	WO	WO
Reset	0	0	0	0	0	0	0	0	0	0	0	0	0	0	0	0
	15	14	13	12	11	10	9	8	7	6	5	4	3	2	1	0
	reserved								DCINT7	DCINT6	DCINT5	DCINT4	DCINT3	DCINT2	DCINT1	DCINT0
Type	RO	RO	RO	RO	RO	RO	RO	RO	WO	WO	WO	WO	WO	WO	WO	WO
Reset	0	0	0	0	0	0	0	0	0	0	0	0	0	0	0	0

Bit/Field	Name	Type	Reset	Description
31:24	reserved	RO	0x00	Software should not rely on the value of a reserved bit. To provide compatibility with future products, the value of a reserved bit should be preserved across a read-modify-write operation.
23	DCTRIG7	WO	0	Digital Comparator Trigger 7 Value Description 0 No effect. 1 Resets the Digital Comparator 7 trigger unit to its initial conditions. When the trigger has been cleared, this bit is automatically cleared. Because the digital comparators use the current and previous ADC conversion values to determine when to assert the trigger, it is important to reset the digital comparator to initial conditions when starting a new sequence so that stale data is not used. After setting this bit, software should wait until the bit clears before continuing.
22	DCTRIG6	WO	0	Digital Comparator Trigger 6 Value Description 0 No effect. 1 Resets the Digital Comparator 6 trigger unit to its initial conditions. When the trigger has been cleared, this bit is automatically cleared. Because the digital comparators use the current and previous ADC conversion values to determine when to assert the trigger, it is important to reset the digital comparator to initial conditions when starting a new sequence so that stale data is not used.

Bit/Field	Name	Type	Reset	Description
21	DCTRIG5	WO	0	<p>Digital Comparator Trigger 5</p> <p>Value Description</p> <p>0 No effect.</p> <p>1 Resets the Digital Comparator 5 trigger unit to its initial conditions.</p> <p>When the trigger has been cleared, this bit is automatically cleared. Because the digital comparators use the current and previous ADC conversion values to determine when to assert the trigger, it is important to reset the digital comparator to initial conditions when starting a new sequence so that stale data is not used.</p>
20	DCTRIG4	WO	0	<p>Digital Comparator Trigger 4</p> <p>Value Description</p> <p>0 No effect.</p> <p>1 Resets the Digital Comparator 4 trigger unit to its initial conditions.</p> <p>When the trigger has been cleared, this bit is automatically cleared. Because the digital comparators use the current and previous ADC conversion values to determine when to assert the trigger, it is important to reset the digital comparator to initial conditions when starting a new sequence so that stale data is not used.</p>
19	DCTRIG3	WO	0	<p>Digital Comparator Trigger 3</p> <p>Value Description</p> <p>0 No effect.</p> <p>1 Resets the Digital Comparator 3 trigger unit to its initial conditions.</p> <p>When the trigger has been cleared, this bit is automatically cleared. Because the digital comparators use the current and previous ADC conversion values to determine when to assert the trigger, it is important to reset the digital comparator to initial conditions when starting a new sequence so that stale data is not used.</p>
18	DCTRIG2	WO	0	<p>Digital Comparator Trigger 2</p> <p>Value Description</p> <p>0 No effect.</p> <p>1 Resets the Digital Comparator 2 trigger unit to its initial conditions.</p> <p>When the trigger has been cleared, this bit is automatically cleared. Because the digital comparators use the current and previous ADC conversion values to determine when to assert the trigger, it is important to reset the digital comparator to initial conditions when starting a new sequence so that stale data is not used.</p>

Bit/Field	Name	Type	Reset	Description
17	DCTRIG1	WO	0	<p>Digital Comparator Trigger 1</p> <p>Value Description</p> <p>0 No effect.</p> <p>1 Resets the Digital Comparator 1 trigger unit to its initial conditions.</p> <p>When the trigger has been cleared, this bit is automatically cleared. Because the digital comparators use the current and previous ADC conversion values to determine when to assert the trigger, it is important to reset the digital comparator to initial conditions when starting a new sequence so that stale data is not used.</p>
16	DCTRIG0	WO	0	<p>Digital Comparator Trigger 0</p> <p>Value Description</p> <p>0 No effect.</p> <p>1 Resets the Digital Comparator 0 trigger unit to its initial conditions.</p> <p>When the trigger has been cleared, this bit is automatically cleared. Because the digital comparators use the current and previous ADC conversion values to determine when to assert the trigger, it is important to reset the digital comparator to initial conditions when starting a new sequence so that stale data is not used.</p>
15:8	reserved	RO	0x00	<p>Software should not rely on the value of a reserved bit. To provide compatibility with future products, the value of a reserved bit should be preserved across a read-modify-write operation.</p>
7	DCINT7	WO	0	<p>Digital Comparator Interrupt 7</p> <p>Value Description</p> <p>0 No effect.</p> <p>1 Resets the Digital Comparator 7 interrupt unit to its initial conditions.</p> <p>When the interrupt has been cleared, this bit is automatically cleared. Because the digital comparators use the current and previous ADC conversion values to determine when to assert the interrupt, it is important to reset the digital comparator to initial conditions when starting a new sequence so that stale data is not used.</p>
6	DCINT6	WO	0	<p>Digital Comparator Interrupt 6</p> <p>Value Description</p> <p>0 No effect.</p> <p>1 Resets the Digital Comparator 6 interrupt unit to its initial conditions.</p> <p>When the interrupt has been cleared, this bit is automatically cleared. Because the digital comparators use the current and previous ADC conversion values to determine when to assert the interrupt, it is important to reset the digital comparator to initial conditions when starting a new sequence so that stale data is not used.</p>

Bit/Field	Name	Type	Reset	Description
5	DCINT5	WO	0	<p>Digital Comparator Interrupt 5</p> <p>Value Description</p> <p>0 No effect.</p> <p>1 Resets the Digital Comparator 5 interrupt unit to its initial conditions.</p> <p>When the interrupt has been cleared, this bit is automatically cleared. Because the digital comparators use the current and previous ADC conversion values to determine when to assert the interrupt, it is important to reset the digital comparator to initial conditions when starting a new sequence so that stale data is not used.</p>
4	DCINT4	WO	0	<p>Digital Comparator Interrupt 4</p> <p>Value Description</p> <p>0 No effect.</p> <p>1 Resets the Digital Comparator 4 interrupt unit to its initial conditions.</p> <p>When the interrupt has been cleared, this bit is automatically cleared. Because the digital comparators use the current and previous ADC conversion values to determine when to assert the interrupt, it is important to reset the digital comparator to initial conditions when starting a new sequence so that stale data is not used.</p>
3	DCINT3	WO	0	<p>Digital Comparator Interrupt 3</p> <p>Value Description</p> <p>0 No effect.</p> <p>1 Resets the Digital Comparator 3 interrupt unit to its initial conditions.</p> <p>When the interrupt has been cleared, this bit is automatically cleared. Because the digital comparators use the current and previous ADC conversion values to determine when to assert the interrupt, it is important to reset the digital comparator to initial conditions when starting a new sequence so that stale data is not used.</p>
2	DCINT2	WO	0	<p>Digital Comparator Interrupt 2</p> <p>Value Description</p> <p>0 No effect.</p> <p>1 Resets the Digital Comparator 2 interrupt unit to its initial conditions.</p> <p>When the interrupt has been cleared, this bit is automatically cleared. Because the digital comparators use the current and previous ADC conversion values to determine when to assert the interrupt, it is important to reset the digital comparator to initial conditions when starting a new sequence so that stale data is not used.</p>

Bit/Field	Name	Type	Reset	Description
1	DCINT1	WO	0	Digital Comparator Interrupt 1 Value Description 0 No effect. 1 Resets the Digital Comparator 1 interrupt unit to its initial conditions. When the interrupt has been cleared, this bit is automatically cleared. Because the digital comparators use the current and previous ADC conversion values to determine when to assert the interrupt, it is important to reset the digital comparator to initial conditions when starting a new sequence so that stale data is not used.
0	DCINT0	WO	0	Digital Comparator Interrupt 0 Value Description 0 No effect. 1 Resets the Digital Comparator 0 interrupt unit to its initial conditions. When the interrupt has been cleared, this bit is automatically cleared. Because the digital comparators use the current and previous ADC conversion values to determine when to assert the interrupt, it is important to reset the digital comparator to initial conditions when starting a new sequence so that stale data is not used.

Register 48: ADC Digital Comparator Control 0 (ADCDCCTL0), offset 0xE00

Register 49: ADC Digital Comparator Control 1 (ADCDCCTL1), offset 0xE04

Register 50: ADC Digital Comparator Control 2 (ADCDCCTL2), offset 0xE08

Register 51: ADC Digital Comparator Control 3 (ADCDCCTL3), offset 0xE0C

Register 52: ADC Digital Comparator Control 4 (ADCDCCTL4), offset 0xE10

Register 53: ADC Digital Comparator Control 5 (ADCDCCTL5), offset 0xE14

Register 54: ADC Digital Comparator Control 6 (ADCDCCTL6), offset 0xE18

Register 55: ADC Digital Comparator Control 7 (ADCDCCTL7), offset 0xE1C

This register provides the comparison encodings that generate an interrupt and/or PWM trigger. See "Interrupt/ADC-Trigger Selector" on page 1799 for more information on using the ADC digital comparators to trigger a PWM generator.

ADC Digital Comparator Control n (ADCDCCTLn)

ADC0 base: 0x4003.8000

ADC1 base: 0x4003.9000

Offset 0xE00

Type RW, reset 0x0000.0000

	31	30	29	28	27	26	25	24	23	22	21	20	19	18	17	16		
	reserved																	
Type	RO	RO	RO	RO	RO	RO	RO	RO	RO	RO	RO	RO	RO	RO	RO	RO		
Reset	0	0	0	0	0	0	0	0	0	0	0	0	0	0	0	0		
	15	14	13	12	11	10	9	8	7	6	5	4	3	2	1	0		
	reserved			CTE	CTC			CTM			reserved			CIE	CIC		CIM	
Type	RO	RO	RO	RW	RW	RW	RW	RW	RO	RO	RO	RW	RW	RW	RW	RW		
Reset	0	0	0	0	0	0	0	0	0	0	0	0	0	0	0	0		

Bit/Field	Name	Type	Reset	Description
31:13	reserved	RO	0x0000.0	Software should not rely on the value of a reserved bit. To provide compatibility with future products, the value of a reserved bit should be preserved across a read-modify-write operation.
12	CTE	RW	0	Comparison Trigger Enable

Value Description

Value	Description
0	Disables the trigger function state machine. ADC conversion data is ignored by the trigger function.
1	Enables the trigger function state machine. The ADC conversion data is used to determine if a trigger should be generated according to the programming of the CTC and CTM fields.

Bit/Field	Name	Type	Reset	Description										
11:10	CTC	RW	0x0	<p>Comparison Trigger Condition</p> <p>This field specifies the operational region in which a trigger is generated when the ADC conversion data is compared against the values of COMP0 and COMP1. The COMP0 and COMP1 fields are defined in the ADCDCMPx registers.</p> <table border="1"> <thead> <tr> <th>Value</th> <th>Description</th> </tr> </thead> <tbody> <tr> <td>0x0</td> <td>Low Band ADC Data < COMP0 ≤ COMP1</td> </tr> <tr> <td>0x1</td> <td>Mid Band COMP0 < ADC Data ≤ COMP1</td> </tr> <tr> <td>0x2</td> <td>reserved</td> </tr> <tr> <td>0x3</td> <td>High Band COMP0 ≤ COMP1 ≤ ADC Data</td> </tr> </tbody> </table>	Value	Description	0x0	Low Band ADC Data < COMP0 ≤ COMP1	0x1	Mid Band COMP0 < ADC Data ≤ COMP1	0x2	reserved	0x3	High Band COMP0 ≤ COMP1 ≤ ADC Data
Value	Description													
0x0	Low Band ADC Data < COMP0 ≤ COMP1													
0x1	Mid Band COMP0 < ADC Data ≤ COMP1													
0x2	reserved													
0x3	High Band COMP0 ≤ COMP1 ≤ ADC Data													
9:8	CTM	RW	0x0	<p>Comparison Trigger Mode</p> <p>This field specifies the mode by which the trigger comparison is made.</p> <table border="1"> <thead> <tr> <th>Value</th> <th>Description</th> </tr> </thead> <tbody> <tr> <td>0x0</td> <td>Always This mode generates a trigger every time the ADC conversion data falls within the selected operational region.</td> </tr> <tr> <td>0x1</td> <td>Once This mode generates a trigger the first time that the ADC conversion data enters the selected operational region.</td> </tr> <tr> <td>0x2</td> <td>Hysteresis Always This mode generates a trigger when the ADC conversion data falls within the selected operational region and continues to generate the trigger until the hysteresis condition is cleared by entering the opposite operational region. Note that the hysteresis modes are only defined for CTC encodings of 0x0 and 0x3.</td> </tr> <tr> <td>0x3</td> <td>Hysteresis Once This mode generates a trigger the first time that the ADC conversion data falls within the selected operational region. No additional triggers are generated until the hysteresis condition is cleared by entering the opposite operational region. Note that the hysteresis modes are only defined for CTC encodings of 0x0 and 0x3.</td> </tr> </tbody> </table>	Value	Description	0x0	Always This mode generates a trigger every time the ADC conversion data falls within the selected operational region.	0x1	Once This mode generates a trigger the first time that the ADC conversion data enters the selected operational region.	0x2	Hysteresis Always This mode generates a trigger when the ADC conversion data falls within the selected operational region and continues to generate the trigger until the hysteresis condition is cleared by entering the opposite operational region. Note that the hysteresis modes are only defined for CTC encodings of 0x0 and 0x3.	0x3	Hysteresis Once This mode generates a trigger the first time that the ADC conversion data falls within the selected operational region. No additional triggers are generated until the hysteresis condition is cleared by entering the opposite operational region. Note that the hysteresis modes are only defined for CTC encodings of 0x0 and 0x3.
Value	Description													
0x0	Always This mode generates a trigger every time the ADC conversion data falls within the selected operational region.													
0x1	Once This mode generates a trigger the first time that the ADC conversion data enters the selected operational region.													
0x2	Hysteresis Always This mode generates a trigger when the ADC conversion data falls within the selected operational region and continues to generate the trigger until the hysteresis condition is cleared by entering the opposite operational region. Note that the hysteresis modes are only defined for CTC encodings of 0x0 and 0x3.													
0x3	Hysteresis Once This mode generates a trigger the first time that the ADC conversion data falls within the selected operational region. No additional triggers are generated until the hysteresis condition is cleared by entering the opposite operational region. Note that the hysteresis modes are only defined for CTC encodings of 0x0 and 0x3.													
7:5	reserved	RO	0x0	Software should not rely on the value of a reserved bit. To provide compatibility with future products, the value of a reserved bit should be preserved across a read-modify-write operation.										

Bit/Field	Name	Type	Reset	Description
4	CIE	RW	0	<p>Comparison Interrupt Enable</p> <p>Value Description</p> <p>0 Disables the comparison interrupt. ADC conversion data has no effect on interrupt generation.</p> <p>1 Enables the comparison interrupt. The ADC conversion data is used to determine if an interrupt should be generated according to the programming of the CIE and CIM fields.</p>
3:2	CIC	RW	0x0	<p>Comparison Interrupt Condition</p> <p>This field specifies the operational region in which an interrupt is generated when the ADC conversion data is compared against the values of COMP0 and COMP1. The COMP0 and COMP1 fields are defined in the ADCDCCMPx registers.</p> <p>Value Description</p> <p>0x0 Low Band ADC Data < COMP0 ≤ COMP1</p> <p>0x1 Mid Band COMP0 ≤ ADC Data < COMP1</p> <p>0x2 reserved</p> <p>0x3 High Band COMP0 < COMP1 ≤ ADC Data</p>
1:0	CIM	RW	0x0	<p>Comparison Interrupt Mode</p> <p>This field specifies the mode by which the interrupt comparison is made.</p> <p>Value Description</p> <p>0x0 Always This mode generates an interrupt every time the ADC conversion data falls within the selected operational region.</p> <p>0x1 Once This mode generates an interrupt the first time that the ADC conversion data enters the selected operational region.</p> <p>0x2 Hysteresis Always This mode generates an interrupt when the ADC conversion data falls within the selected operational region and continues to generate the interrupt until the hysteresis condition is cleared by entering the opposite operational region. Note that the hysteresis modes are only defined for CTC encodings of 0x0 and 0x3.</p> <p>0x3 Hysteresis Once This mode generates an interrupt the first time that the ADC conversion data falls within the selected operational region. No additional interrupts are generated until the hysteresis condition is cleared by entering the opposite operational region. Note that the hysteresis modes are only defined for CTC encodings of 0x0 and 0x3.</p>

Register 56: ADC Digital Comparator Range 0 (ADCDCMP0), offset 0xE40

Register 57: ADC Digital Comparator Range 1 (ADCDCMP1), offset 0xE44

Register 58: ADC Digital Comparator Range 2 (ADCDCMP2), offset 0xE48

Register 59: ADC Digital Comparator Range 3 (ADCDCMP3), offset 0xE4C

Register 60: ADC Digital Comparator Range 4 (ADCDCMP4), offset 0xE50

Register 61: ADC Digital Comparator Range 5 (ADCDCMP5), offset 0xE54

Register 62: ADC Digital Comparator Range 6 (ADCDCMP6), offset 0xE58

Register 63: ADC Digital Comparator Range 7 (ADCDCMP7), offset 0xE5C

This register defines the comparison values that are used to determine if the ADC conversion data falls in the appropriate operating region.

Note: The value in the COMP1 field must be greater than or equal to the value in the COMP0 field or unexpected results can occur.

ADC Digital Comparator Range n (ADCDCMPn)

ADC0 base: 0x4003.8000
 ADC1 base: 0x4003.9000
 Offset 0xE40
 Type RW, reset 0x0000.0000

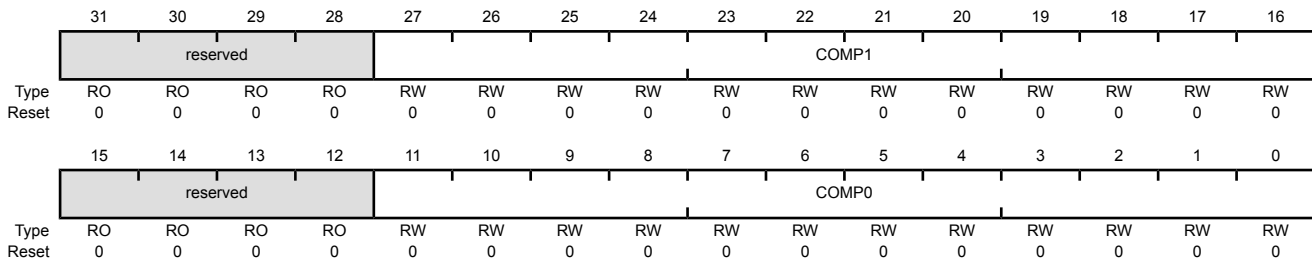

Bit/Field	Name	Type	Reset	Description
31:28	reserved	RO	0x0	Software should not rely on the value of a reserved bit. To provide compatibility with future products, the value of a reserved bit should be preserved across a read-modify-write operation.
27:16	COMP1	RW	0x000	Compare 1 The value in this field is compared against the ADC conversion data. The result of the comparison is used to determine if the data lies within the high-band region. Note that the value of COMP1 must be greater than or equal to the value of COMP0.
15:12	reserved	RO	0x0	Software should not rely on the value of a reserved bit. To provide compatibility with future products, the value of a reserved bit should be preserved across a read-modify-write operation.
11:0	COMP0	RW	0x000	Compare 0 The value in this field is compared against the ADC conversion data. The result of the comparison is used to determine if the data lies within the low-band region.

Register 64: ADC Peripheral Properties (ADCPP), offset 0xFC0

The **ADCPP** register provides information regarding the properties of the ADC module.

ADC Peripheral Properties (ADCPP)

ADC0 base: 0x4003.8000
 ADC1 base: 0x4003.9000
 Offset 0xFC0
 Type RO, reset 0x01B0.2147

	31	30	29	28	27	26	25	24	23	22	21	20	19	18	17	16
	reserved							APSHT	TS	RSL				TYPE		
Type	RO	RO	RO	RO	RO	RO	RO	RO	RO	RO	RO	RO	RO	RO	RO	RO
Reset	0	0	0	0	0	0	0	1	1	0	1	1	0	0	0	0
	15	14	13	12	11	10	9	8	7	6	5	4	3	2	1	0
	DC				CH						MCR					
Type	RO	RO	RO	RO	RO	RO	RO	RO	RO	RO	RO	RO	RO	RO	RO	RO
Reset	0	0	1	0	0	0	0	1	0	1	0	0	0	0	1	1

Bit/Field	Name	Type	Reset	Description
31:25	reserved	RO	0x00	Software should not rely on the value of a reserved bit. To provide compatibility with future products, the value of a reserved bit should be preserved across a read-modify-write operation.
24	APSHT	RO	0x1	Application-Programmable Sample-and-Hold Time This bit indicates the ADC has the capability of allowing the application to adjust the sample and hold window period.
23	TS	RO	0x1	Temperature Sensor Value Description 0 The ADC module does not have a temperature sensor. 1 The ADC module has a temperature sensor. This field provides the similar information as the legacy DC1 register TEMPSNS bit.
22:18	RSL	RO	0xC	Resolution This field specifies the maximum number of binary bits used to represent the converted sample. The field is encoded as a binary value, in the range of 0 to 32 bits.
17:16	TYPE	RO	0x0	ADC Architecture Value Description 0x0 SAR 0x1 - 0x3 Reserved
15:10	DC	RO	0x8	Digital Comparator Count This field specifies the number of ADC digital comparators available to the converter. The field is encoded as a binary value, in the range of 0 to 63. This field provides similar information to the legacy DC9 register ADCnDCn bits.

Bit/Field	Name	Type	Reset	Description								
9:4	CH	RO	0x14	<p>ADC Channel Count</p> <p>This field specifies the number of ADC input channels available to the converter. This field is encoded as a binary value, in the range of 0 to 63.</p> <p>This field provides similar information to the legacy DC3 and DC8 register ADCnAINn bits.</p>								
3:0	MCR	RO	0x7	<p>Maximum Conversion Rate</p> <p>This field specifies the maximum value that may be programmed into the ADCPC register's CR field.</p> <table><thead><tr><th>Value</th><th>Description</th></tr></thead><tbody><tr><td>0x0-0x6</td><td>Reserved</td></tr><tr><td>0x7</td><td>Full conversion rate (F_{CONV}) as defined by T_{ADC} and N_{SH}.</td></tr><tr><td>0x8 - 0xF</td><td>Reserved</td></tr></tbody></table>	Value	Description	0x0-0x6	Reserved	0x7	Full conversion rate (F_{CONV}) as defined by T_{ADC} and N_{SH} .	0x8 - 0xF	Reserved
Value	Description											
0x0-0x6	Reserved											
0x7	Full conversion rate (F_{CONV}) as defined by T_{ADC} and N_{SH} .											
0x8 - 0xF	Reserved											

Register 65: ADC Peripheral Configuration (ADCPC), offset 0xFC4

The **ADCPC** register provides information regarding the configuration of the peripheral.

ADC Peripheral Configuration (ADCPC)

ADC0 base: 0x4003.8000
 ADC1 base: 0x4003.9000
 Offset 0xFC4
 Type RW, reset 0x0000.0007

	31	30	29	28	27	26	25	24	23	22	21	20	19	18	17	16
	reserved															
Type	RO	RO	RO	RO	RO	RO	RO	RO	RO	RO	RO	RO	RO	RO	RO	RO
Reset	0	0	0	0	0	0	0	0	0	0	0	0	0	0	0	0
	15	14	13	12	11	10	9	8	7	6	5	4	3	2	1	0
	reserved												MCR			
Type	RO	RO	RO	RO	RO	RO	RO	RO	RO	RO	RO	RO	RW	RW	RW	RW
Reset	0	0	0	0	0	0	0	0	0	0	0	0	0	1	1	1

Bit/Field	Name	Type	Reset	Description																				
31:4	reserved	RO	0x0000.0000	Software should not rely on the value of a reserved bit. To provide compatibility with future products, the value of a reserved bit should be preserved across a read-modify-write operation.																				
3:0	MCR	RW	0x7	<p>Conversion Rate</p> <p>This field specifies the relative sample rate of the ADC and is used in run, sleep, and deep-sleep modes. It allows the application to reduce the rate at which conversions are generated relative to the maximum conversion rate.</p> <table border="1"> <thead> <tr> <th>Value</th> <th>Description</th> </tr> </thead> <tbody> <tr> <td>0x0</td> <td>Reserved</td> </tr> <tr> <td>0x1</td> <td>Eighth conversion rate. After a conversion completes, the logic pauses for 112 T_{ADC} periods before starting the next conversion.</td> </tr> <tr> <td>0x2</td> <td>Reserved</td> </tr> <tr> <td>0x3</td> <td>Quarter conversion rate. After a conversion completes, the logic pauses for 48 T_{ADC} periods before starting the next conversion.</td> </tr> <tr> <td>0x4</td> <td>Reserved</td> </tr> <tr> <td>0x5</td> <td>Half conversion rate. After a conversion completes, the logic pauses for 16 T_{ADC} periods before starting the next conversion.</td> </tr> <tr> <td>0x6</td> <td>Reserved</td> </tr> <tr> <td>0x7</td> <td>Full conversion rate (F_{CONV}) as defined by T_{ADC} and N_{SH}.</td> </tr> <tr> <td>0x8 - 0xF</td> <td>Reserved</td> </tr> </tbody> </table>	Value	Description	0x0	Reserved	0x1	Eighth conversion rate. After a conversion completes, the logic pauses for 112 T _{ADC} periods before starting the next conversion.	0x2	Reserved	0x3	Quarter conversion rate. After a conversion completes, the logic pauses for 48 T _{ADC} periods before starting the next conversion.	0x4	Reserved	0x5	Half conversion rate. After a conversion completes, the logic pauses for 16 T _{ADC} periods before starting the next conversion.	0x6	Reserved	0x7	Full conversion rate (F _{CONV}) as defined by T _{ADC} and N _{SH} .	0x8 - 0xF	Reserved
Value	Description																							
0x0	Reserved																							
0x1	Eighth conversion rate. After a conversion completes, the logic pauses for 112 T _{ADC} periods before starting the next conversion.																							
0x2	Reserved																							
0x3	Quarter conversion rate. After a conversion completes, the logic pauses for 48 T _{ADC} periods before starting the next conversion.																							
0x4	Reserved																							
0x5	Half conversion rate. After a conversion completes, the logic pauses for 16 T _{ADC} periods before starting the next conversion.																							
0x6	Reserved																							
0x7	Full conversion rate (F _{CONV}) as defined by T _{ADC} and N _{SH} .																							
0x8 - 0xF	Reserved																							

Register 66: ADC Clock Configuration (ADCCC), offset 0xFC8

The **ADCCC** register controls the clock source for the ADC module.

ADC Clock Configuration (ADCCC)

ADC0 base: 0x4003.8000
 ADC1 base: 0x4003.9000
 Offset 0xFC8
 Type RW, reset 0x0000.0001

	31	30	29	28	27	26	25	24	23	22	21	20	19	18	17	16
	reserved															
Type	RO	RO	RO	RO	RO	RO	RO	RO	RO	RO	RO	RO	RO	RO	RO	RO
Reset	0	0	0	0	0	0	0	0	0	0	0	0	0	0	0	0
	15	14	13	12	11	10	9	8	7	6	5	4	3	2	1	0
	reserved						CLKDIV						CS			
Type	RO	RO	RO	RO	RO	RO	RW	RW	RW	RW	RW	RW	RW	RW	RW	RW
Reset	0	0	0	0	0	0	0	0	0	0	0	0	0	0	0	1

Bit/Field	Name	Type	Reset	Description
31:10	reserved	RO	0x0000.00	Software should not rely on the value of a reserved bit. To provide compatibility with future products, the value of a reserved bit should be preserved across a read-modify-write operation.
9:4	CLKDIV	RW	0x0	PLL VCO Clock Divisor Value Description 0x0 /1 0x1 /2 0x2 /3 0xN /(N + 1)
3:0	CS	RW	0x1	ADC Clock Source Value Description 0x0 PLL VCO divided by CLKDIV. 0x1 Alternate clock source as defined by ALTCLKCFG register in System Control Module. 0x2 MOSC 0x2 - 0xF Reserved

19 Universal Asynchronous Receivers/Transmitters (UARTs)

The TM4C129ENC PDT controller includes eight Universal Asynchronous Receiver/Transmitter (UART) with the following features:

- Programmable baud-rate generator allowing speeds up to 7.5 Mbps for regular speed (divide by 16) and 15 Mbps for high speed (divide by 8)
- Separate 16x8 transmit (TX) and receive (RX) FIFOs to reduce CPU interrupt service loading
- Programmable FIFO length, including 1-byte deep operation providing conventional double-buffered interface
- FIFO trigger levels of 1/8, 1/4, 1/2, 3/4, and 7/8
- Standard asynchronous communication bits for start, stop, and parity
- Line-break generation and detection
- Fully programmable serial interface characteristics
 - 5, 6, 7, or 8 data bits
 - Even, odd, stick, or no-parity bit generation/detection
 - 1 or 2 stop bit generation
- IrDA serial-IR (SIR) encoder/decoder providing
 - Programmable use of IrDA Serial Infrared (SIR) or UART input/output
 - Support of IrDA SIR encoder/decoder functions for data rates up to 115.2 Kbps half-duplex
 - Support of normal 3/16 and low-power (1.41-2.23 μ s) bit durations
 - Programmable internal clock generator enabling division of reference clock by 1 to 256 for low-power mode bit duration
- Support for communication with ISO 7816 smart cards
- Modem functionality available on the following UARTs:
 - UART0 (modem flow control and modem status)
 - UART1 (modem flow control and modem status)
 - UART2 (modem flow control)
 - UART3 (modem flow control)
 - UART4 (modem flow control)
- EIA-485 9-bit support

- Standard FIFO-level and End-of-Transmission interrupts
- Efficient transfers using Micro Direct Memory Access Controller (μDMA)
 - Separate channels for transmit and receive
 - Receive single request asserted when data is in the FIFO; burst request asserted at programmed FIFO level
 - Transmit single request asserted when there is space in the FIFO; burst request asserted at programmed FIFO level
- Global Alternate Clock (ALTCLK) resource or System Clock (SYSCLK) can be used to generate baud clock

19.1 Block Diagram

Figure 19-1. UART Module Block Diagram

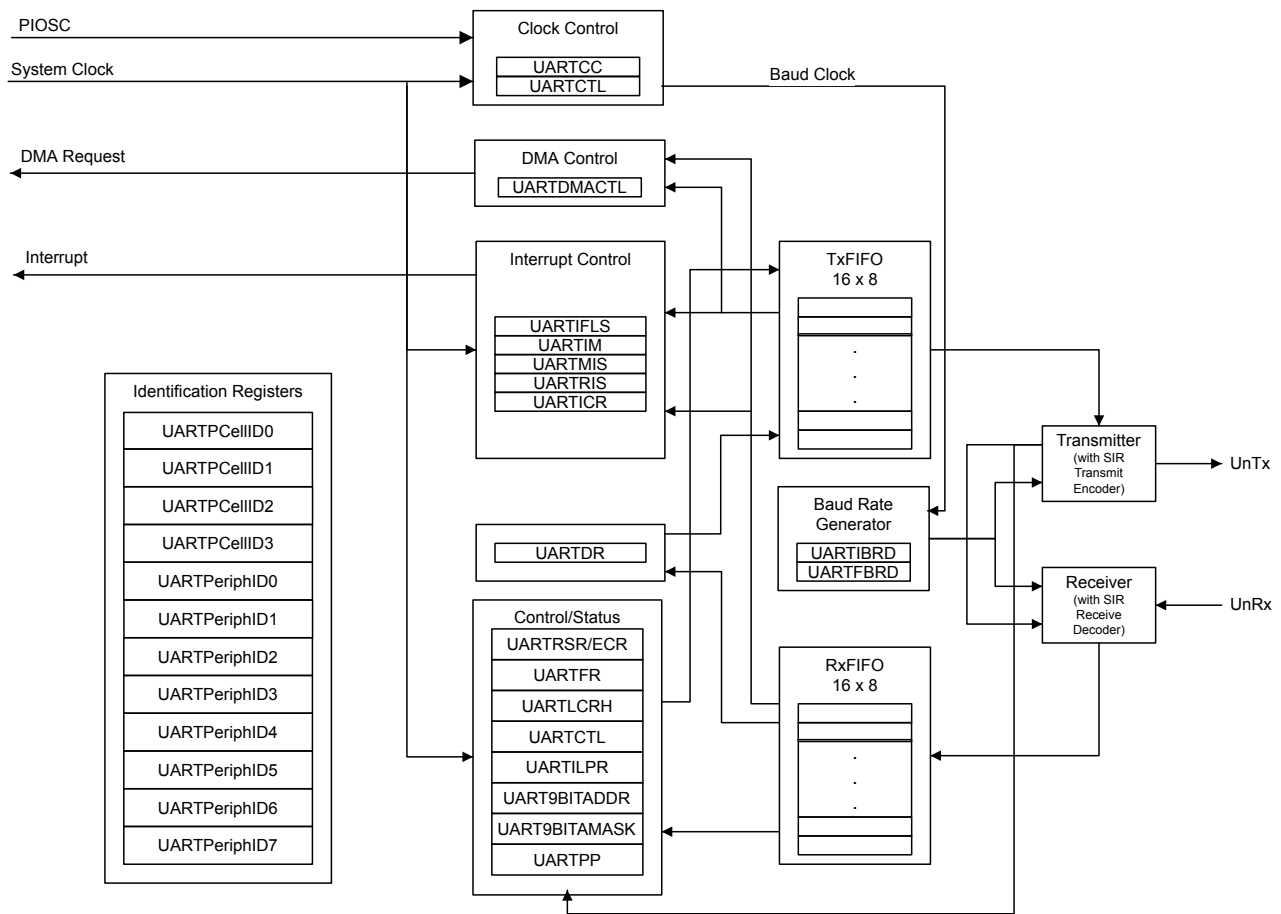

19.2 Signal Description

The following table lists the external signals of the UART module and describes the function of each. The UART signals are alternate functions for some GPIO signals and default to be GPIO signals at reset. The column in the table below titled "Pin Mux/Pin Assignment" lists the possible GPIO pin

placements for these UART signals. The **AFSEL** bit in the **GPIO Alternate Function Select (GPIOAFSEL)** register (page 778) should be set to choose the UART function. The number in parentheses is the encoding that must be programmed into the **PMC_n** field in the **GPIO Port Control (GPIOPTL)** register (page 795) to assign the UART signal to the specified GPIO port pin. For more information on configuring GPIOs, see “General-Purpose Input/Outputs (GPIOs)” on page 750.

Table 19-1. UART Signals (128TQFP)

Pin Name	Pin Number	Pin Mux / Pin Assignment	Pin Type	Buffer Type	Description
U0CTS	30 74 121	PH1 (1) PM4 (1) PB4 (1)	I	TTL	UART module 0 Clear To Send modem flow control input signal.
U0DCD	31 73 104	PH2 (1) PM5 (1) PP3 (2)	I	TTL	UART module 0 Data Carrier Detect modem status input signal.
U0DSR	32 72 105	PH3 (1) PM6 (1) PP4 (2)	I	TTL	UART module 0 Data Set Ready modem output control line.
U0DTR	103	PP2 (1)	O	TTL	UART module 0 Data Terminal Ready modem status input signal.
U0RI	60 71	PK7 (1) PM7 (1)	I	TTL	UART module 0 Ring Indicator modem status input signal.
U0RTS	29 120	PH0 (1) PB5 (1)	O	TTL	UART module 0 Request to Send modem flow control output signal.
U0Rx	33	PA0 (1)	I	TTL	UART module 0 receive.
U0Tx	34	PA1 (1)	O	TTL	UART module 0 transmit.
U1CTS	104 108	PP3 (1) PN1 (1)	I	TTL	UART module 1 Clear To Send modem flow control input signal.
U1DCD	13 109	PE2 (1) PN2 (1)	I	TTL	UART module 1 Data Carrier Detect modem status input signal.
U1DSR	14 110	PE1 (1) PN3 (1)	I	TTL	UART module 1 Data Set Ready modem output control line.
U1DTR	12 111	PE3 (1) PN4 (1)	O	TTL	UART module 1 Data Terminal Ready modem status input signal.
U1RI	112 123	PN5 (1) PE4 (1)	I	TTL	UART module 1 Ring Indicator modem status input signal.
U1RTS	15 107	PE0 (1) PN0 (1)	O	TTL	UART module 1 Request to Send modem flow control output line.
U1Rx	95 102	PB0 (1) PQ4 (1)	I	TTL	UART module 1 receive.
U1Tx	96	PB1 (1)	O	TTL	UART module 1 transmit.
U2CTS	110 128	PN3 (2) PD7 (1)	I	TTL	UART module 2 Clear To Send modem flow control input signal.
U2RTS	109 127	PN2 (2) PD6 (1)	O	TTL	UART module 2 Request to Send modem flow control output line.
U2Rx	40 125	PA6 (1) PD4 (1)	I	TTL	UART module 2 receive.
U2Tx	41 126	PA7 (1) PD5 (1)	O	TTL	UART module 2 transmit.
U3CTS	106 112	PP5 (1) PN5 (2)	I	TTL	UART module 3 Clear To Send modem flow control input signal.

Table 19-1. UART Signals (128TQFP) (continued)

Pin Name	Pin Number	Pin Mux / Pin Assignment	Pin Type	Buffer Type	Description
U3RTS	105 111	PP4 (1) PN4 (2)	O	TTL	UART module 3 Request to Send modem flow control output line.
U3Rx	37 116	PA4 (1) PJ0 (1)	I	TTL	UART module 3 receive.
U3Tx	38 117	PA5 (1) PJ1 (1)	O	TTL	UART module 3 transmit.
U4CTS	21	PK3 (1)	I	TTL	UART module 4 Clear To Send modem flow control input signal.
U4RTS	20	PK2 (1)	O	TTL	UART module 4 Request to Send modem flow control output line.
U4Rx	18 35	PK0 (1) PA2 (1)	I	TTL	UART module 4 receive.
U4Tx	19 36	PK1 (1) PA3 (1)	O	TTL	UART module 4 transmit.
U5Rx	23	PC6 (1)	I	TTL	UART module 5 receive.
U5Tx	22	PC7 (1)	O	TTL	UART module 5 transmit.
U6Rx	118	PP0 (1)	I	TTL	UART module 6 receive.
U6Tx	119	PP1 (1)	O	TTL	UART module 6 transmit.
U7Rx	25	PC4 (1)	I	TTL	UART module 7 receive.
U7Tx	24	PC5 (1)	O	TTL	UART module 7 transmit.

19.3 Functional Description

Each TM4C129ENCPDT UART performs the functions of parallel-to-serial and serial-to-parallel conversions. It is similar in functionality to a 16C550 UART, but is not register compatible.

The UART is configured for transmit and/or receive via the TXE and RXE bits of the **UART Control (UARTCTL)** register (see page 1312). Transmit and receive are both enabled out of reset. Before any control registers are programmed, the UART must be disabled by clearing the UARTEN bit in **UARTCTL**. If the UART is disabled during a TX or RX operation, the current transaction is completed prior to the UART stopping.

The UART module also includes a serial IR (SIR) encoder/decoder block that can be connected to an infrared transceiver to implement an IrDA SIR physical layer. The SIR function is programmed using the **UARTCTL** register.

19.3.1 Transmit/Receive Logic

The transmit logic performs parallel-to-serial conversion on the data read from the transmit FIFO. The control logic outputs the serial bit stream beginning with a start bit and followed by the data bits (LSB first), parity bit, and the stop bits according to the programmed configuration in the control registers. See Figure 19-2 on page 1289 for details.

The receive logic performs serial-to-parallel conversion on the received bit stream after a valid start pulse has been detected. Overrun, parity, frame error checking, and line-break detection are also performed, and their status accompanies the data that is written to the receive FIFO.

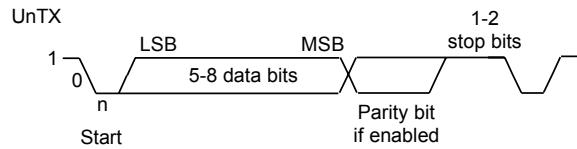
Figure 19-2. UART Character Frame

19.3.2 Baud-Rate Generation

The baud-rate divisor is a 22-bit number consisting of a 16-bit integer and a 6-bit fractional part. The number formed by these two values is used by the baud-rate generator to determine the bit period. Having a fractional baud-rate divisor allows the UART to generate all the standard baud rates.

The 16-bit integer is loaded through the **UART Integer Baud-Rate Divisor (UARTIBRD)** register (see page 1308) and the 6-bit fractional part is loaded with the **UART Fractional Baud-Rate Divisor (UARTFBRD)** register (see page 1309). The baud-rate divisor (BRD) has the following relationship to the system clock (where *BRDI* is the integer part of the BRD and *BRDF* is the fractional part, separated by a decimal place.)

$$BRD = BRDI + BRDF = \text{UARTSysClk} / (\text{ClkDiv} * \text{Baud Rate})$$

where *UARTSysClk* is the system clock connected to the UART, and *ClkDiv* is either 16 (if *HSE* in **UARTCTL** is clear) or 8 (if *HSE* is set). By default, this will be the main system clock described in “Clock Control” on page 237. Alternatively, the UART may be clocked from the internal precision oscillator (PIOSC), independent of the system clock selection. This will allow the UART clock to be programmed independently of the system clock PLL settings. See the **UARTCC** register for more details.

The 6-bit fractional number (that is to be loaded into the *DIVFRAC* bit field in the **UARTFBRD** register) can be calculated by taking the fractional part of the baud-rate divisor, multiplying it by 64, and adding 0.5 to account for rounding errors:

$$\text{UARTFBRD}[\text{DIVFRAC}] = \text{integer}(\text{BRDF} * 64 + 0.5)$$

The UART generates an internal baud-rate reference clock at 8x or 16x the baud-rate (referred to as *Baud8* and *Baud16*, depending on the setting of the *HSE* bit (bit 5) in **UARTCTL**). This reference clock is divided by 8 or 16 to generate the transmit clock, and is used for error detection during receive operations. Note that the state of the *HSE* bit has no effect on clock generation in ISO 7816 smart card mode (when the *SMART* bit in the **UARTCTL** register is set).

Along with the **UART Line Control, High Byte (UARTLCRH)** register (see page 1310), the **UARTIBRD** and **UARTFBRD** registers form an internal 30-bit register. This internal register is only updated when a write operation to **UARTLCRH** is performed, so any changes to the baud-rate divisor must be followed by a write to the **UARTLCRH** register for the changes to take effect.

To update the baud-rate registers, there are four possible sequences:

- **UARTIBRD** write, **UARTFBRD** write, and **UARTLCRH** write
- **UARTFBRD** write, **UARTIBRD** write, and **UARTLCRH** write
- **UARTIBRD** write and **UARTLCRH** write
- **UARTFBRD** write and **UARTLCRH** write

19.3.3 Data Transmission

Data received or transmitted is stored in two 16-byte FIFOs, though the receive FIFO has an extra four bits per character for status information. For transmission, data is written into the transmit FIFO. If the UART is enabled, it causes a data frame to start transmitting with the parameters indicated in the **UARTLCRH** register. Data continues to be transmitted until there is no data left in the transmit FIFO. The **BUSY** bit in the **UART Flag (UARTFR)** register (see page 1304) is asserted as soon as data is written to the transmit FIFO (that is, if the FIFO is non-empty) and remains asserted while data is being transmitted. The **BUSY** bit is negated only when the transmit FIFO is empty, and the last character has been transmitted from the shift register, including the stop bits. The UART can indicate that it is busy even though the UART may no longer be enabled.

When the receiver is idle (the $UnRx$ signal is continuously 1), and the data input goes Low (a start bit has been received), the receive counter begins running and data is sampled on the eighth cycle of $Baud_{16}$ or fourth cycle of $Baud_8$ depending on the setting of the **HSE** bit (bit 5) in **UARTCTL** (described in “Transmit/Receive Logic” on page 1288).

The start bit is valid and recognized if the $UnRx$ signal is still low on the eighth cycle of $Baud_{16}$ (**HSE** clear) or the fourth cycle of $Baud_8$ (**HSE** set), otherwise it is ignored. After a valid start bit is detected, successive data bits are sampled on every 16th cycle of $Baud_{16}$ or 8th cycle of $Baud_8$ (that is, one bit period later) according to the programmed length of the data characters and value of the **HSE** bit in **UARTCTL**. The parity bit is then checked if parity mode is enabled. Data length and parity are defined in the **UARTLCRH** register.

Lastly, a valid stop bit is confirmed if the $UnRx$ signal is High, otherwise a framing error has occurred. When a full word is received, the data is stored in the receive FIFO along with any error bits associated with that word.

19.3.4 Serial IR (SIR)

The UART peripheral includes an IrDA serial-IR (SIR) encoder/decoder block. The IrDA SIR block provides functionality that converts between an asynchronous UART data stream and a half-duplex serial SIR interface. No analog processing is performed on-chip. The role of the SIR block is to provide a digital encoded output and decoded input to the UART. When enabled, the SIR block uses the $UnTx$ and $UnRx$ pins for the SIR protocol. These signals should be connected to an infrared transceiver to implement an IrDA SIR physical layer link. The SIR block can receive and transmit, but it is only half-duplex so it cannot do both at the same time. Transmission must be stopped before data can be received. The IrDA SIR physical layer specifies a minimum 10-ms delay between transmission and reception. The SIR block has two modes of operation:

- In normal IrDA mode, a zero logic level is transmitted as a high pulse of 3/16th duration of the selected baud rate bit period on the output pin, while logic one levels are transmitted as a static LOW signal. These levels control the driver of an infrared transmitter, sending a pulse of light for each zero. On the reception side, the incoming light pulses energize the photo transistor base of the receiver, pulling its output LOW and driving the UART input pin LOW.
- In low-power IrDA mode, the width of the transmitted infrared pulse is set to three times the period of the internally generated $IrLPBaud_{16}$ signal (1.63 μ s, assuming a nominal 1.8432 MHz frequency) by changing the appropriate bit in the **UARTCTL** register (see page 1312).

Whether the device is in normal or low-power IrDA mode, a start bit is deemed valid if the decoder is still Low, one period of $IrLPBaud_{16}$ after the Low was first detected. This enables a normal-mode UART to receive data from a low-power mode UART that can transmit pulses as small as 1.41 μ s. Thus, for both low-power and normal mode operation, the **ILPDVSR** field in the **UARTILPR** register must be programmed such that $1.42 \text{ MHz} < F_{IrLPBaud_{16}} < 2.12 \text{ MHz}$, resulting in a low-power pulse

duration of 1.41–2.11 μs (three times the period of IrLPBaud16). The minimum frequency of IrLPBaud16 ensures that pulses less than one period of IrLPBaud16 are rejected, but pulses greater than 1.4 μs are accepted as valid pulses.

Figure 19-3 on page 1291 shows the UART transmit and receive signals, with and without IrDA modulation.

Figure 19-3. IrDA Data Modulation

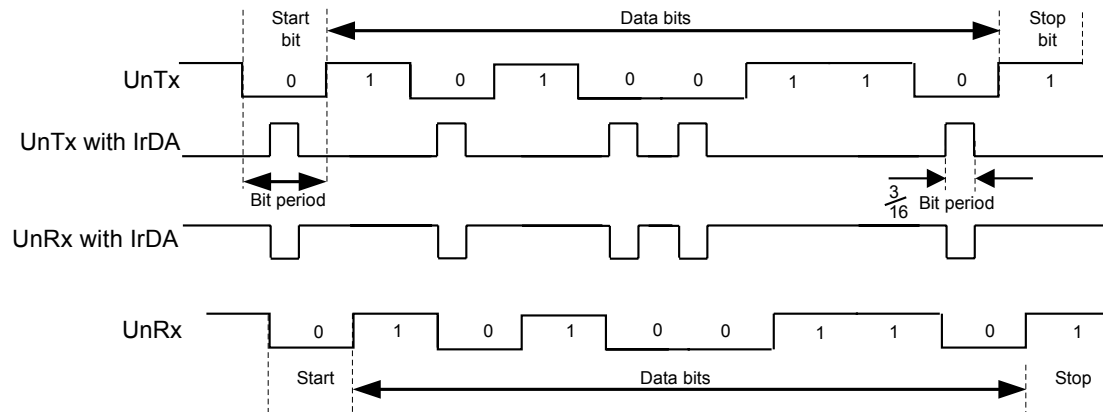

In both normal and low-power IrDA modes:

- During transmission, the UART data bit is used as the base for encoding
- During reception, the decoded bits are transferred to the UART receive logic

The IrDA SIR physical layer specifies a half-duplex communication link, with a minimum 10-ms delay between transmission and reception. This delay must be generated by software because it is not automatically supported by the UART. The delay is required because the infrared receiver electronics might become biased or even saturated from the optical power coupled from the adjacent transmitter LED. This delay is known as latency or receiver setup time.

19.3.5 ISO 7816 Support

The UART offers basic support to allow communication with an ISO 7816 smartcard. When bit 3 (**SMART**) of the **UARTCTL** register is set, the **UnTx** signal is used as a bit clock, and the **UnRx** signal is used as the half-duplex communication line connected to the smartcard. A GPIO signal can be used to generate the reset signal to the smartcard. The remaining smartcard signals should be provided by the system design. The maximum clock rate in this mode is system clock / 16.

When using ISO 7816 mode, the **UARTLCRH** register must be set to transmit 8-bit words (**WLEN** bits 6:5 configured to 0x3) with EVEN parity (**PEN** set and **EPS** set). In this mode, the UART automatically uses 2 stop bits, and the **STP2** bit of the **UARTLCRH** register is ignored.

If a parity error is detected during transmission, **UnRx** is pulled Low during the second stop bit. In this case, the UART aborts the transmission, flushes the transmit FIFO and discards any data it contains, and raises a parity error interrupt, allowing software to detect the problem and initiate retransmission of the affected data. Note that the UART does not support automatic retransmission in this case.

19.3.6 Modem Handshake Support

This section describes how to configure and use the modem flow control and status signals for a UART when connected as a DTE (data terminal equipment) or as a DCE (data communications equipment). In general, a modem is a DCE and a computing device that connects to a modem is the DTE.

19.3.6.1 Signaling

The status signals provided by a UART differ based on whether the UART is used as a DTE or DCE. When used as a DTE, the modem flow control and status signals are defined as:

- $\overline{\text{UnCTS}}$ is Clear To Send
- $\overline{\text{UnDSR}}$ is Data Set Ready
- $\overline{\text{UnDCD}}$ is Data Carrier Detect
- $\overline{\text{UnRI}}$ is Ring Indicator
- $\overline{\text{UnRTS}}$ is Request To Send
- $\overline{\text{UnDTR}}$ is Data Terminal Ready

When used as a DCE, the modem flow control and status signals are defined as:

- $\overline{\text{UnCTS}}$ is Request To Send
- $\overline{\text{UnDSR}}$ is Data Terminal Ready
- $\overline{\text{UnRTS}}$ is Clear To Send
- $\overline{\text{UnDTR}}$ is Data Set Ready

Note that the support for DCE functions Data Carrier Detect and Ring Indicator are not provided. If these signals are required, their function can be emulated by using a general-purpose I/O signal and providing software support.

19.3.6.2 Flow Control

Flow control can be accomplished by either hardware or software. The following sections describe the different methods.

Hardware Flow Control (RTS/CTS)

Hardware flow control between two devices is accomplished by connecting the $\overline{\text{UnRTS}}$ output to the Clear-To-Send input on the receiving device, and connecting the Request-To-Send output on the receiving device to the $\overline{\text{UnCTS}}$ input.

The $\overline{\text{UnCTS}}$ input controls the transmitter. The transmitter may only transmit data when the $\overline{\text{UnCTS}}$ input is asserted. The $\overline{\text{UnRTS}}$ output signal indicates the state of the receive FIFO. $\overline{\text{UnCTS}}$ remains asserted until the preprogrammed watermark level is reached, indicating that the Receive FIFO has no space to store additional characters.

The **UARTCTL** register bits 15 (CTSEN) and 14 (RTSEN) specify the flow control mode as shown in Table 19-2 on page 1293.

Table 19-2. Flow Control Mode

CTSEN	RTSEN	Description
1	1	RTS and CTS flow control enabled
1	0	Only CTS flow control enabled
0	1	Only RTS flow control enabled
0	0	Both RTS and CTS flow control disabled

Note that when `RTSEN` is 1, software cannot modify the `UARTCTL` `Request to Send (RTS)` bit, and the status of the `RTS` bit should be ignored.

Software Flow Control (Modem Status Interrupts)

Software flow control between two devices is accomplished by using interrupts to indicate the status of the UART. Interrupts may be generated for the `UnDSR`, `UnDCD`, `UnCTS`, and `UnRI` signals using bits 3:0 of the `UARTIM` register, respectively. The raw and masked interrupt status may be checked using the `UARTTRIS` and `UARTMIS` register. These interrupts may be cleared using the `UARTICR` register.

19.3.7 9-Bit UART Mode

The UART provides a 9-bit mode that is enabled with the `9BITEN` bit in the `UART9BITADDR` register. This feature is useful in a multi-drop configuration of the UART where a single master connected to multiple slaves can communicate with a particular slave through its address or set of addresses along with a qualifier for an address byte. All the slaves check for the address qualifier in the place of the parity bit and, if set, then compare the byte received with the preprogrammed address. If the address matches, then it receives or sends further data. If the address does not match, it drops the address byte and any subsequent data bytes. If the UART is in 9-bit mode, then the receiver operates with no parity mode. The address can be predefined to match with the received byte and it can be configured with the `UART9BITADDR` register. The matching can be extended to a set of addresses using the address mask in the `UART9BITAMASK` register. By default, the `UART9BITAMASK` is `0xFF`, meaning that only the specified address is matched.

When not finding a match, the rest of the data bytes with the 9th bit cleared are dropped. If a match is found, then an interrupt is generated to the NVIC for further action. The subsequent data bytes with the cleared 9th bit are stored in the FIFO. Software can mask this interrupt in case `μDMA` and/or FIFO operations are enabled for this instance and processor intervention is not required. All the send transactions with 9-bit mode are data bytes and the 9th bit is cleared. Software can override the 9th bit to be set (to indicate address) by overriding the parity settings to sticky parity with odd parity enabled for a particular byte. To match the transmission time with correct parity settings, the address byte can be transmitted as a single then a burst transfer. The Transmit FIFO does not hold the address/data bit, hence software should take care of enabling the address bit appropriately.

19.3.8 FIFO Operation

The UART has two 16x8 FIFOs; one for transmit and one for receive. Both FIFOs are accessed via the **UART Data (UARTDR)** register (see page 1299). Read operations of the `UARTDR` register return a 12-bit value consisting of 8 data bits and 4 error flags while write operations place 8-bit data in the transmit FIFO.

Out of reset, both FIFOs are disabled and act as 1-byte-deep holding registers. The FIFOs are enabled by setting the `FEN` bit in `UARTLCRH` (page 1310).

FIFO status can be monitored via the **UART Flag (UARTFR)** register (see page 1304) and the **UART Receive Status (UARTRSR)** register. Hardware monitors empty, full and overrun conditions. The

UARTFR register contains empty and full flags (TXFE, TXFF, RXFE, and RXFF bits), and the **UARTSR** register shows overrun status via the OE bit. If the FIFOs are disabled, the empty and full flags are set according to the status of the 1-byte-deep holding registers.

The trigger points at which the FIFOs generate interrupts is controlled via the **UART Interrupt FIFO Level Select (UARTIFLS)** register (see page 1316). Both FIFOs can be individually configured to trigger interrupts at different levels. Available configurations include $\frac{1}{8}$, $\frac{1}{4}$, $\frac{1}{2}$, $\frac{3}{4}$, and $\frac{7}{8}$. For example, if the $\frac{1}{4}$ option is selected for the receive FIFO, the UART generates a receive interrupt after 4 data bytes are received. Out of reset, both FIFOs are configured to trigger an interrupt at the $\frac{1}{2}$ mark.

19.3.9 Interrupts

The UART can generate interrupts when the following conditions are observed:

- Overrun Error
- Break Error
- Parity Error
- Framing Error
- Receive Timeout
- Transmit (when condition defined in the TXIFLSEL bit in the **UARTIFLS** register is met, or if the EOT bit in **UARTCTL** is set, when the last bit of all transmitted data leaves the serializer)
- Receive (when condition defined in the RXIFLSEL bit in the **UARTIFLS** register is met)

All of the interrupt events are ORed together before being sent to the interrupt controller, so the UART can only generate a single interrupt request to the controller at any given time. Software can service multiple interrupt events in a single interrupt service routine by reading the **UART Masked Interrupt Status (UARTMIS)** register (see page 1326).

The interrupt events that can trigger a controller-level interrupt are defined in the **UART Interrupt Mask (UARTIM)** register (see page 1318) by setting the corresponding IM bits. If interrupts are not used, the raw interrupt status is visible via the **UART Raw Interrupt Status (UARTRIS)** register (see page 1322).

Note: For receive timeout, the RTIM bit in the **UARTIM** register must be set to see the RTMIS and RTRIS status in the **UARTMIS** and **UARTRIS** registers.

Interrupts are always cleared (for both the **UARTMIS** and **UARTRIS** registers) by writing a 1 to the corresponding bit in the **UART Interrupt Clear (UARTICR)** register (see page 1330).

The receive timeout interrupt is asserted when the receive FIFO is not empty, and no further data is received over a 32-bit period when the HSE bit is clear or over a 64-bit period when the HSE bit is set. The receive timeout interrupt is cleared either when the FIFO becomes empty through reading all the data (or by reading the holding register), or when a 1 is written to the corresponding bit in the **UARTICR** register.

The receive interrupt changes state when one of the following events occurs:

- If the FIFOs are enabled and the receive FIFO reaches the programmed trigger level, the RXRIS bit is set. The receive interrupt is cleared by reading data from the receive FIFO until it becomes less than the trigger level, or by clearing the interrupt by writing a 1 to the RXIC bit.

- If the FIFOs are disabled (have a depth of one location) and data is received thereby filling the location, the `RXRIS` bit is set. The receive interrupt is cleared by performing a single read of the receive FIFO, or by clearing the interrupt by writing a 1 to the `RXIC` bit.

The transmit interrupt changes state when one of the following events occurs:

- If the FIFOs are enabled and the transmit FIFO progresses through the programmed trigger level, the `TXRIS` bit is set. The transmit interrupt is based on a transition through level, therefore the FIFO must be written past the programmed trigger level otherwise no further transmit interrupts will be generated. The transmit interrupt is cleared by writing data to the transmit FIFO until it becomes greater than the trigger level, or by clearing the interrupt by writing a 1 to the `TXIC` bit.
- If the FIFOs are disabled (have a depth of one location) and there is no data present in the transmitters single location, the `TXRIS` bit is set. It is cleared by performing a single write to the transmit FIFO, or by clearing the interrupt by writing a 1 to the `TXIC` bit.

19.3.10 Loopback Operation

The UART can be placed into an internal loopback mode for diagnostic or debug work by setting the `LBE` bit in the `UARTCTL` register (see page 1312). In loopback mode, data transmitted on the `UnTx` output is received on the `UnRx` input. Note that the `LBE` bit should be set before the UART is enabled.

19.3.11 DMA Operation

The UART provides an interface to the μ DMA controller with separate channels for transmit and receive. The DMA operation of the UART is enabled through the **UART DMA Control (UARTDMACTL)** register. When DMA operation is enabled, the UART asserts a DMA request on the receive or transmit channel when the associated FIFO can transfer data. For the receive channel, a single transfer request is asserted whenever any data is in the receive FIFO. A burst transfer request is asserted whenever the amount of data in the receive FIFO is at or above the FIFO trigger level configured in the `UARTIFLS` register. For the transmit channel, a single transfer request is asserted whenever there is at least one empty location in the transmit FIFO. The burst request is asserted whenever the transmit FIFO contains fewer characters than the FIFO trigger level. The single and burst DMA transfer requests are handled automatically by the μ DMA controller depending on how the DMA channel is configured.

To enable DMA operation for the receive channel, set the `RXDMAE` bit of the **DMA Control (UARTDMACTL)** register. To enable DMA operation for the transmit channel, set the `TXDMAE` bit of the `UARTDMACTL` register. The UART can also be configured to stop using DMA for the receive channel if a receive error occurs. If the `DMAERR` bit of the `UARTDMACR` register is set and a receive error occurs, the DMA receive requests are automatically disabled. This error condition can be cleared by clearing the appropriate UART error interrupt.

When the μ DMA is finished transferring data to the TX FIFO or from the RX FIFO, a `dma_done` signal is sent to the UART to indicate completion. The `dma_done` status is indicated through the `DMATXRIS` and `DMARXIS` bits of the `UARTRIS` register. An interrupt can be generated from these status bits by setting the `DMATXIM` and/or `DMARXIM` bits in the `UARTIM` register.

Note: The `DMATXRIS` bit can be used to indicate the μ DMA's completion of data transfer to the TX FIFO. To indicate transfer completion from the UART's serializer, the end-of-transmission bit (`EOT` bit) should be enabled in the `UARTCTL` register. An interrupt can be generated on an end-of-transmission completion by setting the `EOTIM` bit of the `UARTIM` register.

See “Micro Direct Memory Access (μ DMA)” on page 686 for more details about programming the μ DMA controller.

19.4 Initialization and Configuration

To enable and initialize the UART, the following steps are necessary:

1. Enable the UART module using the **RCGCUART** register (see page 395).
2. Enable the clock to the appropriate GPIO module via the **RCGCGPIO** register (see page 389). To find out which GPIO port to enable, refer to Table 29-5 on page 1932.
3. Set the GPIO **AFSEL** bits for the appropriate pins (see page 778). To determine which GPIOs to configure, see Table 29-4 on page 1921.
4. Configure the GPIO current level and/or slew rate as specified for the mode selected (see page 780 and page 788).
5. Configure the **PMCn** fields in the **GPIOPCTL** register to assign the UART signals to the appropriate pins (see page 795 and Table 29-5 on page 1932).

To use the UART, the peripheral clock must be enabled by setting the appropriate bit in the **RCGCUART** register (page 395). In addition, the clock to the appropriate GPIO module must be enabled via the **RCGCGPIO** register (page 389) in the System Control module. To find out which GPIO port to enable, refer to Table 29-5 on page 1932.

This section discusses the steps that are required to use a UART module. For this example, the UART clock is assumed to be 20 MHz, and the desired UART configuration is:

- 115200 baud rate
- Data length of 8 bits
- One stop bit
- No parity
- FIFOs disabled
- No interrupts

The first thing to consider when programming the UART is the baud-rate divisor (BRD), because the **UARTIBRD** and **UARTFBRD** registers must be written before the **UARTLCRH** register. Using the equation described in “Baud-Rate Generation” on page 1289, the BRD can be calculated:

$$\text{BRD} = 20,000,000 / (16 * 115,200) = 10.8507$$

which means that the **DIVINT** field of the **UARTIBRD** register (see page 1308) should be set to 10 decimal or 0xA. The value to be loaded into the **UARTFBRD** register (see page 1309) is calculated by the equation:

$$\text{UARTFBRD}[\text{DIVFRAC}] = \text{integer}(0.8507 * 64 + 0.5) = 54$$

With the BRD values in hand, the UART configuration is written to the module in the following order:

1. Disable the UART by clearing the **UARTEN** bit in the **UARTCTL** register.
2. Write the integer portion of the BRD to the **UARTIBRD** register.
3. Write the fractional portion of the BRD to the **UARTFBRD** register.

4. Write the desired serial parameters to the **UARTLCRH** register (in this case, a value of 0x0000.0060).
5. Configure the UART clock source by writing to the **UARTCC** register.
6. Optionally, configure the μ DMA channel (see “Micro Direct Memory Access (μ DMA)” on page 686) and enable the DMA option(s) in the **UARTDMACTL** register.
7. Enable the UART by setting the **UARTEN** bit in the **UARTCTL** register.

19.5 Register Map

Table 19-3 on page 1297 lists the UART registers. The offset listed is a hexadecimal increment to the register's address, relative to that UART's base address:

- UART0: 0x4000.C000
- UART1: 0x4000.D000
- UART2: 0x4000.E000
- UART3: 0x4000.F000
- UART4: 0x4001.0000
- UART5: 0x4001.1000
- UART6: 0x4001.2000
- UART7: 0x4001.3000

The UART module clock must be enabled before the registers can be programmed (see page 395). There must be a delay of 3 system clocks after the UART module clock is enabled before any UART module registers are accessed.

The UART must be disabled (see the **UARTEN** bit in the **UARTCTL** register on page 1312) before any of the control registers are reprogrammed. When the UART is disabled during a TX or RX operation, the current transaction is completed prior to the UART stopping.

Note: Registers that contain bits for modem control or status only apply to the following UARTs:

- UART0 (modem flow control and modem status)
- UART1 (modem flow control and modem status)
- UART2 (modem flow control)
- UART3 (modem flow control)
- UART4 (modem flow control)

Table 19-3. UART Register Map

Offset	Name	Type	Reset	Description	See page
0x000	UARTDR	RW	0x0000.0000	UART Data	1299
0x004	UARTRSR/UARTECR	RW	0x0000.0000	UART Receive Status/Error Clear	1301
0x018	UARTFR	RO	0x0000.0090	UART Flag	1304
0x020	UARTILPR	RW	0x0000.0000	UART IrDA Low-Power Register	1307

Table 19-3. UART Register Map (continued)

Offset	Name	Type	Reset	Description	See page
0x024	UARTIBRD	RW	0x0000.0000	UART Integer Baud-Rate Divisor	1308
0x028	UARTFBRD	RW	0x0000.0000	UART Fractional Baud-Rate Divisor	1309
0x02C	UARTLCRH	RW	0x0000.0000	UART Line Control	1310
0x030	UARTCTL	RW	0x0000.0300	UART Control	1312
0x034	UARTIFLS	RW	0x0000.0012	UART Interrupt FIFO Level Select	1316
0x038	UARTIM	RW	0x0000.0000	UART Interrupt Mask	1318
0x03C	UARTRIS	RO	0x0000.0000	UART Raw Interrupt Status	1322
0x040	UARTMIS	RO	0x0000.0000	UART Masked Interrupt Status	1326
0x044	UARTICR	W1C	0x0000.0000	UART Interrupt Clear	1330
0x048	UARTDMACTL	RW	0x0000.0000	UART DMA Control	1332
0x0A4	UART9BITADDR	RW	0x0000.0000	UART 9-Bit Self Address	1333
0x0A8	UART9BITAMASK	RW	0x0000.00FF	UART 9-Bit Self Address Mask	1334
0xFC0	UARTPP	RO	0x0000.000F	UART Peripheral Properties	1335
0xFC8	UARTCC	RW	0x0000.0000	UART Clock Configuration	1337
0xFD0	UARTPeriphID4	RO	0x0000.0060	UART Peripheral Identification 4	1338
0xFD4	UARTPeriphID5	RO	0x0000.0000	UART Peripheral Identification 5	1339
0xFD8	UARTPeriphID6	RO	0x0000.0000	UART Peripheral Identification 6	1340
0xFDC	UARTPeriphID7	RO	0x0000.0000	UART Peripheral Identification 7	1341
0xFE0	UARTPeriphID0	RO	0x0000.0011	UART Peripheral Identification 0	1342
0xFE4	UARTPeriphID1	RO	0x0000.0000	UART Peripheral Identification 1	1343
0xFE8	UARTPeriphID2	RO	0x0000.0018	UART Peripheral Identification 2	1344
0xFEC	UARTPeriphID3	RO	0x0000.0001	UART Peripheral Identification 3	1345
0xFF0	UARTPCellID0	RO	0x0000.000D	UART PrimeCell Identification 0	1346
0xFF4	UARTPCellID1	RO	0x0000.00F0	UART PrimeCell Identification 1	1347
0xFF8	UARTPCellID2	RO	0x0000.0005	UART PrimeCell Identification 2	1348
0xFFC	UARTPCellID3	RO	0x0000.00B1	UART PrimeCell Identification 3	1349

19.6 Register Descriptions

The remainder of this section lists and describes the UART registers, in numerical order by address offset.

Register 1: UART Data (UARTDR), offset 0x000

Important: This register is read-sensitive. See the register description for details.

This register is the data register (the interface to the FIFOs).

For transmitted data, if the FIFO is enabled, data written to this location is pushed onto the transmit FIFO. If the FIFO is disabled, data is stored in the transmitter holding register (the bottom word of the transmit FIFO). A write to this register initiates a transmission from the UART.

For received data, if the FIFO is enabled, the data byte and the 4-bit status (break, frame, parity, and overrun) is pushed onto the 12-bit wide receive FIFO. If the FIFO is disabled, the data byte and status are stored in the receiving holding register (the bottom word of the receive FIFO). The received data can be retrieved by reading this register.

UART Data (UARTDR)

UART0 base: 0x4000.C000
 UART1 base: 0x4000.D000
 UART2 base: 0x4000.E000
 UART3 base: 0x4000.F000
 UART4 base: 0x4001.0000
 UART5 base: 0x4001.1000
 UART6 base: 0x4001.2000
 UART7 base: 0x4001.3000
 Offset 0x000
 Type RW, reset 0x0000.0000

	31	30	29	28	27	26	25	24	23	22	21	20	19	18	17	16
	reserved															
Type	RO	RO	RO	RO	RO	RO	RO	RO	RO	RO	RO	RO	RO	RO	RO	RO
Reset	0	0	0	0	0	0	0	0	0	0	0	0	0	0	0	0
	15	14	13	12	11	10	9	8	7	6	5	4	3	2	1	0
	reserved				OE	BE	PE	FE	DATA							
Type	RO	RO	RO	RO	RO	RO	RO	RO	RW	RW	RW	RW	RW	RW	RW	RW
Reset	0	0	0	0	0	0	0	0	0	0	0	0	0	0	0	0

Bit/Field	Name	Type	Reset	Description
31:12	reserved	RO	0x0000.0	Software should not rely on the value of a reserved bit. To provide compatibility with future products, the value of a reserved bit should be preserved across a read-modify-write operation.
11	OE	RO	0	UART Overrun Error
				Value Description
				0 No data has been lost due to a FIFO overrun.
				1 New data was received when the FIFO was full, resulting in data loss.

Bit/Field	Name	Type	Reset	Description
10	BE	RO	0	<p>UART Break Error</p> <p>Value Description</p> <p>0 No break condition has occurred</p> <p>1 A break condition has been detected, indicating that the receive data input was held Low for longer than a full-word transmission time (defined as start, data, parity, and stop bits).</p> <p>In FIFO mode, this error is associated with the character at the top of the FIFO. When a break occurs, only one 0 character is loaded into the FIFO. The next character is only enabled after the received data input goes to a 1 (marking state), and the next valid start bit is received.</p>
9	PE	RO	0	<p>UART Parity Error</p> <p>Value Description</p> <p>0 No parity error has occurred</p> <p>1 The parity of the received data character does not match the parity defined by bits 2 and 7 of the UARTLCRH register.</p> <p>In FIFO mode, this error is associated with the character at the top of the FIFO.</p>
8	FE	RO	0	<p>UART Framing Error</p> <p>Value Description</p> <p>0 No framing error has occurred</p> <p>1 The received character does not have a valid stop bit (a valid stop bit is 1).</p>
7:0	DATA	RW	0x00	<p>Data Transmitted or Received</p> <p>Data that is to be transmitted via the UART is written to this field. When read, this field contains the data that was received by the UART.</p>

Register 2: UART Receive Status/Error Clear (UARTRSR/UARTECR), offset 0x004

The **UARTRSR/UARTECR** register is the receive status register/error clear register.

In addition to the **UARTDR** register, receive status can also be read from the **UARTRSR** register. If the status is read from this register, then the status information corresponds to the entry read from **UARTDR** prior to reading **UARTRSR**. The status information for overrun is set immediately when an overrun condition occurs.

The **UARTRSR** register cannot be written.

A write of any value to the **UARTECR** register clears the framing, parity, break, and overrun errors. All the bits are cleared on reset.

Read-Only Status Register

UART Receive Status/Error Clear (UARTRSR/UARTECR)

UART0 base: 0x4000.C000
 UART1 base: 0x4000.D000
 UART2 base: 0x4000.E000
 UART3 base: 0x4000.F000
 UART4 base: 0x4001.0000
 UART5 base: 0x4001.1000
 UART6 base: 0x4001.2000
 UART7 base: 0x4001.3000
 Offset 0x004
 Type RO, reset 0x0000.0000

	31	30	29	28	27	26	25	24	23	22	21	20	19	18	17	16	
	reserved																
Type	RO	RO	RO	RO	RO	RO	RO	RO	RO	RO	RO	RO	RO	RO	RO	RO	
Reset	0	0	0	0	0	0	0	0	0	0	0	0	0	0	0	0	
	15	14	13	12	11	10	9	8	7	6	5	4	3	2	1	0	
	reserved													OE	BE	PE	FE
Type	RO	RO	RO	RO	RO	RO	RO	RO	RO	RO	RO	RO	RO	RO	RO	RO	
Reset	0	0	0	0	0	0	0	0	0	0	0	0	0	0	0	0	

Bit/Field	Name	Type	Reset	Description
31:4	reserved	RO	0x0000.000	Software should not rely on the value of a reserved bit. To provide compatibility with future products, the value of a reserved bit should be preserved across a read-modify-write operation.

3	OE	RO	0	UART Overrun Error
---	----	----	---	--------------------

Value Description

Value	Description
0	No data has been lost due to a FIFO overrun.
1	New data was received when the FIFO was full, resulting in data loss.

This bit is cleared by a write to **UARTECR**.

The FIFO contents remain valid because no further data is written when the FIFO is full, only the contents of the shift register are overwritten. The CPU must read the data in order to empty the FIFO.

Bit/Field	Name	Type	Reset	Description
2	BE	RO	0	<p>UART Break Error</p> <p>Value Description</p> <p>0 No break condition has occurred</p> <p>1 A break condition has been detected, indicating that the receive data input was held Low for longer than a full-word transmission time (defined as start, data, parity, and stop bits).</p> <p>This bit is cleared to 0 by a write to UARTECR.</p> <p>In FIFO mode, this error is associated with the character at the top of the FIFO. When a break occurs, only one 0 character is loaded into the FIFO. The next character is only enabled after the receive data input goes to a 1 (marking state) and the next valid start bit is received.</p>
1	PE	RO	0	<p>UART Parity Error</p> <p>Value Description</p> <p>0 No parity error has occurred</p> <p>1 The parity of the received data character does not match the parity defined by bits 2 and 7 of the UARTLCRH register.</p> <p>This bit is cleared to 0 by a write to UARTECR.</p>
0	FE	RO	0	<p>UART Framing Error</p> <p>Value Description</p> <p>0 No framing error has occurred</p> <p>1 The received character does not have a valid stop bit (a valid stop bit is 1).</p> <p>This bit is cleared to 0 by a write to UARTECR.</p> <p>In FIFO mode, this error is associated with the character at the top of the FIFO.</p>

Write-Only Error Clear Register

UART Receive Status/Error Clear (UARTRSR/UARTECR)

UART0 base: 0x4000.C000
 UART1 base: 0x4000.D000
 UART2 base: 0x4000.E000
 UART3 base: 0x4000.F000
 UART4 base: 0x4001.0000
 UART5 base: 0x4001.1000
 UART6 base: 0x4001.2000
 UART7 base: 0x4001.3000
 Offset 0x004
 Type WO, reset 0x0000.0000

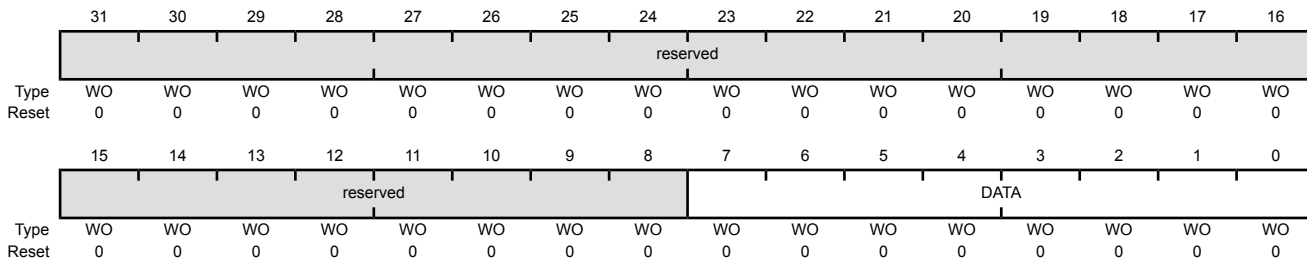

Bit/Field	Name	Type	Reset	Description
31:8	reserved	WO	0x0000.00	Software should not rely on the value of a reserved bit. To provide compatibility with future products, the value of a reserved bit should be preserved across a read-modify-write operation.
7:0	DATA	WO	0x00	Error Clear A write to this register of any data clears the framing, parity, break, and overrun flags.

Register 3: UART Flag (UARTFR), offset 0x018

The **UARTFR** register is the flag register. After reset, the **TXFF**, **RXFF**, and **BUSY** bits are 0, and **TXFE** and **RXFE** bits are 1.

Note: Registers that contain bits for modem control or status only apply to the following UARTs:

- UART0 (modem flow control and modem status)
- UART1 (modem flow control and modem status)
- UART2 (modem flow control)
- UART3 (modem flow control)
- UART4 (modem flow control)

UART Flag (UARTFR)

UART0 base: 0x4000.C000
 UART1 base: 0x4000.D000
 UART2 base: 0x4000.E000
 UART3 base: 0x4000.F000
 UART4 base: 0x4001.0000
 UART5 base: 0x4001.1000
 UART6 base: 0x4001.2000
 UART7 base: 0x4001.3000
 Offset 0x018
 Type RO, reset 0x0000.0090

	31	30	29	28	27	26	25	24	23	22	21	20	19	18	17	16
	reserved															
Type	RO	RO	RO	RO	RO	RO	RO	RO	RO	RO	RO	RO	RO	RO	RO	RO
Reset	0	0	0	0	0	0	0	0	0	0	0	0	0	0	0	0
	15	14	13	12	11	10	9	8	7	6	5	4	3	2	1	0
	reserved							RI	TXFE	RXFF	TXFF	RXFE	BUSY	DCD	DSR	CTS
Type	RO	RO	RO	RO	RO	RO	RO	RO	RO	RO	RO	RO	RO	RO	RO	RO
Reset	0	0	0	0	0	0	0	0	1	0	0	1	0	0	0	0

Bit/Field	Name	Type	Reset	Description
31:9	reserved	RO	0x0000.00	Software should not rely on the value of a reserved bit. To provide compatibility with future products, the value of a reserved bit should be preserved across a read-modify-write operation.
8	RI	RO	0	Ring Indicator
				Value Description
			0	The U_nRI signal is not asserted.
			1	The U_nRI signal is asserted.

Bit/Field	Name	Type	Reset	Description
7	TXFE	RO	1	<p>UART Transmit FIFO Empty</p> <p>The meaning of this bit depends on the state of the <code>FEN</code> bit in the UARTLCRH register.</p> <p>Value Description</p> <p>0 The transmitter has data to transmit.</p> <p>1 If the FIFO is disabled (<code>FEN</code> is 0), the transmit holding register is empty. If the FIFO is enabled (<code>FEN</code> is 1), the transmit FIFO is empty.</p>
6	RXFF	RO	0	<p>UART Receive FIFO Full</p> <p>The meaning of this bit depends on the state of the <code>FEN</code> bit in the UARTLCRH register.</p> <p>Value Description</p> <p>0 The receiver can receive data.</p> <p>1 If the FIFO is disabled (<code>FEN</code> is 0), the receive holding register is full. If the FIFO is enabled (<code>FEN</code> is 1), the receive FIFO is full.</p>
5	TXFF	RO	0	<p>UART Transmit FIFO Full</p> <p>The meaning of this bit depends on the state of the <code>FEN</code> bit in the UARTLCRH register.</p> <p>Value Description</p> <p>0 The transmitter is not full.</p> <p>1 If the FIFO is disabled (<code>FEN</code> is 0), the transmit holding register is full. If the FIFO is enabled (<code>FEN</code> is 1), the transmit FIFO is full.</p>
4	RXFE	RO	1	<p>UART Receive FIFO Empty</p> <p>The meaning of this bit depends on the state of the <code>FEN</code> bit in the UARTLCRH register.</p> <p>Value Description</p> <p>0 The receiver is not empty.</p> <p>1 If the FIFO is disabled (<code>FEN</code> is 0), the receive holding register is empty. If the FIFO is enabled (<code>FEN</code> is 1), the receive FIFO is empty.</p>

Bit/Field	Name	Type	Reset	Description
3	BUSY	RO	0	UART Busy Value Description 0 The UART is not busy. 1 The UART is busy transmitting data. This bit remains set until the complete byte, including all stop bits, has been sent from the shift register. This bit is set as soon as the transmit FIFO becomes non-empty (regardless of whether UART is enabled).
2	DCD	RO	0	Data Carrier Detect Value Description 0 The UnDCD signal is not asserted. 1 The UnDCD signal is asserted.
1	DSR	RO	0	Data Set Ready Value Description 0 The UnDSR signal is not asserted. 1 The UnDSR signal is asserted.
0	CTS	RO	0	Clear To Send Value Description 0 The UlCTS signal is not asserted. 1 The UnCTS signal is asserted.

Register 4: UART IrDA Low-Power Register (UARTILPR), offset 0x020

The **UARTILPR** register stores the 8-bit low-power counter divisor value used to derive the low-power SIR pulse width clock by dividing down the system clock (SysClk). All the bits are cleared when reset.

The internal $F_{IrLPBaud16}$ clock is generated by dividing down SysClk according to the low-power divisor value written to **UARTILPR**. The duration of SIR pulses generated when low-power mode is enabled is three times the period of the $F_{IrLPBaud16}$ clock. The low-power divisor value is calculated as follows:

$$ILPDVSR = SysClk / F_{IrLPBaud16}$$

where $F_{IrLPBaud16}$ is nominally 1.8432 MHz.

Because the $F_{IrLPBaud16}$ clock is used to sample transmitted data irrespective of mode, the ILPDVSR field must be programmed in both low power and normal mode, such that $1.42 \text{ MHz} < F_{IrLPBaud16} < 2.12 \text{ MHz}$, resulting in a low-power pulse duration of 1.41–2.11 μs (three times the period of $F_{IrLPBaud16}$). The minimum frequency of $F_{IrLPBaud16}$ ensures that pulses less than one period of $F_{IrLPBaud16}$ are rejected, but pulses greater than 1.4 μs are accepted as valid pulses.

Note: Zero is an illegal value. Programming a zero value results in no $F_{IrLPBaud16}$ pulses being generated.

UART IrDA Low-Power Register (UARTILPR)

UART0 base: 0x4000.C000
 UART1 base: 0x4000.D000
 UART2 base: 0x4000.E000
 UART3 base: 0x4000.F000
 UART4 base: 0x4001.0000
 UART5 base: 0x4001.1000
 UART6 base: 0x4001.2000
 UART7 base: 0x4001.3000
 Offset 0x020
 Type RW, reset 0x0000.0000

	31	30	29	28	27	26	25	24	23	22	21	20	19	18	17	16
	reserved															
Type	RO	RO	RO	RO	RO	RO	RO	RO	RO	RO	RO	RO	RO	RO	RO	RO
Reset	0	0	0	0	0	0	0	0	0	0	0	0	0	0	0	0
	15	14	13	12	11	10	9	8	7	6	5	4	3	2	1	0
	reserved								ILPDVSR							
Type	RO	RO	RO	RO	RO	RO	RO	RO	RW	RW	RW	RW	RW	RW	RW	RW
Reset	0	0	0	0	0	0	0	0	0	0	0	0	0	0	0	0

Bit/Field	Name	Type	Reset	Description
31:8	reserved	RO	0x0000.00	Software should not rely on the value of a reserved bit. To provide compatibility with future products, the value of a reserved bit should be preserved across a read-modify-write operation.
7:0	ILPDVSR	RW	0x00	IrDA Low-Power Divisor This field contains the 8-bit low-power divisor value.

Register 5: UART Integer Baud-Rate Divisor (UARTIBRD), offset 0x024

The **UARTIBRD** register is the integer part of the baud-rate divisor value. All the bits are cleared on reset. The minimum possible divide ratio is 1 (when **UARTIBRD**=0), in which case the **UARTFBRD** register is ignored. When changing the **UARTIBRD** register, the new value does not take effect until transmission/reception of the current character is complete. Any changes to the baud-rate divisor must be followed by a write to the **UARTLCRH** register. See “Baud-Rate Generation” on page 1289 for configuration details.

UART Integer Baud-Rate Divisor (UARTIBRD)

UART0 base: 0x4000.C000
 UART1 base: 0x4000.D000
 UART2 base: 0x4000.E000
 UART3 base: 0x4000.F000
 UART4 base: 0x4001.0000
 UART5 base: 0x4001.1000
 UART6 base: 0x4001.2000
 UART7 base: 0x4001.3000
 Offset 0x024
 Type RW, reset 0x0000.0000

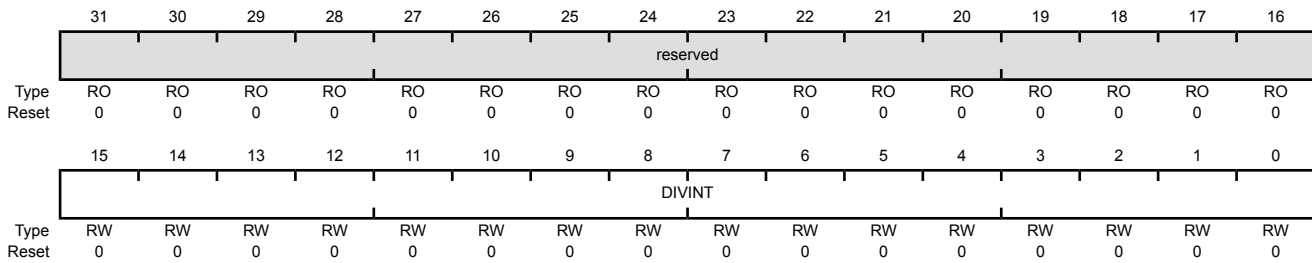

Bit/Field	Name	Type	Reset	Description
31:16	reserved	RO	0x0000	Software should not rely on the value of a reserved bit. To provide compatibility with future products, the value of a reserved bit should be preserved across a read-modify-write operation.
15:0	DIVINT	RW	0x0000	Integer Baud-Rate Divisor

Register 6: UART Fractional Baud-Rate Divisor (UARTFBRD), offset 0x028

The **UARTFBRD** register is the fractional part of the baud-rate divisor value. All the bits are cleared on reset. When changing the **UARTFBRD** register, the new value does not take effect until transmission/reception of the current character is complete. Any changes to the baud-rate divisor must be followed by a write to the **UARTLCRH** register. See “Baud-Rate Generation” on page 1289 for configuration details.

UART Fractional Baud-Rate Divisor (UARTFBRD)

UART0 base: 0x4000.C000
 UART1 base: 0x4000.D000
 UART2 base: 0x4000.E000
 UART3 base: 0x4000.F000
 UART4 base: 0x4001.0000
 UART5 base: 0x4001.1000
 UART6 base: 0x4001.2000
 UART7 base: 0x4001.3000
 Offset 0x028
 Type RW, reset 0x0000.0000

	31	30	29	28	27	26	25	24	23	22	21	20	19	18	17	16
	reserved															
Type	RO	RO	RO	RO	RO	RO	RO	RO	RO	RO	RO	RO	RO	RO	RO	RO
Reset	0	0	0	0	0	0	0	0	0	0	0	0	0	0	0	0
	15	14	13	12	11	10	9	8	7	6	5	4	3	2	1	0
	reserved											DIVFRAC				
Type	RO	RO	RO	RO	RO	RO	RO	RO	RO	RO	RW	RW	RW	RW	RW	RW
Reset	0	0	0	0	0	0	0	0	0	0	0	0	0	0	0	0

Bit/Field	Name	Type	Reset	Description
31:6	reserved	RO	0x0000.000	Software should not rely on the value of a reserved bit. To provide compatibility with future products, the value of a reserved bit should be preserved across a read-modify-write operation.
5:0	DIVFRAC	RW	0x0	Fractional Baud-Rate Divisor

Register 7: UART Line Control (UARTLCRH), offset 0x02C

The **UARTLCRH** register is the line control register. Serial parameters such as data length, parity, and stop bit selection are implemented in this register.

When updating the baud-rate divisor (**UARTIBRD** and/or **UARTIFRD**), the **UARTLCRH** register must also be written. The write strobe for the baud-rate divisor registers is tied to the **UARTLCRH** register.

UART Line Control (UARTLCRH)

UART0 base: 0x4000.C000
 UART1 base: 0x4000.D000
 UART2 base: 0x4000.E000
 UART3 base: 0x4000.F000
 UART4 base: 0x4001.0000
 UART5 base: 0x4001.1000
 UART6 base: 0x4001.2000
 UART7 base: 0x4001.3000
 Offset 0x02C
 Type RW, reset 0x0000.0000

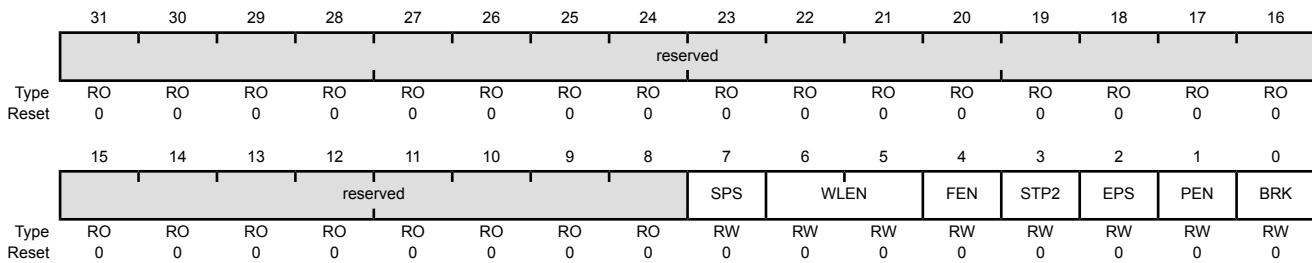

Bit/Field	Name	Type	Reset	Description										
31:8	reserved	RO	0x0000.00	Software should not rely on the value of a reserved bit. To provide compatibility with future products, the value of a reserved bit should be preserved across a read-modify-write operation.										
7	SPS	RW	0	UART Stick Parity Select When bits 1, 2, and 7 of UARTLCRH are set, the parity bit is transmitted and checked as a 0. When bits 1 and 7 are set and 2 is cleared, the parity bit is transmitted and checked as a 1. When this bit is cleared, stick parity is disabled.										
6:5	WLEN	RW	0x0	UART Word Length The bits indicate the number of data bits transmitted or received in a frame as follows: <table border="1" style="margin-left: 20px;"> <thead> <tr> <th>Value</th> <th>Description</th> </tr> </thead> <tbody> <tr> <td>0x0</td> <td>5 bits (default)</td> </tr> <tr> <td>0x1</td> <td>6 bits</td> </tr> <tr> <td>0x2</td> <td>7 bits</td> </tr> <tr> <td>0x3</td> <td>8 bits</td> </tr> </tbody> </table>	Value	Description	0x0	5 bits (default)	0x1	6 bits	0x2	7 bits	0x3	8 bits
Value	Description													
0x0	5 bits (default)													
0x1	6 bits													
0x2	7 bits													
0x3	8 bits													

Bit/Field	Name	Type	Reset	Description
4	FEN	RW	0	UART Enable FIFOs Value Description 0 The FIFOs are disabled (Character mode). The FIFOs become 1-byte-deep holding registers. 1 The transmit and receive FIFO buffers are enabled (FIFO mode).
3	STP2	RW	0	UART Two Stop Bits Select Value Description 0 One stop bit is transmitted at the end of a frame. 1 Two stop bits are transmitted at the end of a frame. The receive logic does not check for two stop bits being received. When in 7816 smartcard mode (the SMART bit is set in the UARTCTL register), the number of stop bits is forced to 2.
2	EPS	RW	0	UART Even Parity Select Value Description 0 Odd parity is performed, which checks for an odd number of 1s. 1 Even parity generation and checking is performed during transmission and reception, which checks for an even number of 1s in data and parity bits. This bit has no effect when parity is disabled by the PEN bit.
1	PEN	RW	0	UART Parity Enable Value Description 0 Parity is disabled and no parity bit is added to the data frame. 1 Parity checking and generation is enabled.
0	BRK	RW	0	UART Send Break Value Description 0 Normal use. 1 A Low level is continually output on the UnTx signal, after completing transmission of the current character. For the proper execution of the break command, software must set this bit for at least two frames (character periods).

Register 8: UART Control (UARTCTL), offset 0x030

The **UARTCTL** register is the control register. All the bits are cleared on reset except for the Transmit Enable (TXE) and Receive Enable (RXE) bits, which are set.

To enable the UART module, the **UARTEN** bit must be set. If software requires a configuration change in the module, the **UARTEN** bit must be cleared before the configuration changes are written. If the UART is disabled during a transmit or receive operation, the current transaction is completed prior to the UART stopping.

Note: Registers that contain bits for modem control or status only apply to the following UARTs:

- UART0 (modem flow control and modem status)
- UART1 (modem flow control and modem status)
- UART2 (modem flow control)
- UART3 (modem flow control)
- UART4 (modem flow control)

Note: The **UARTCTL** register should not be changed while the UART is enabled or else the results are unpredictable. The following sequence is recommended for making changes to the **UARTCTL** register.

1. Disable the UART.
2. Wait for the end of transmission or reception of the current character.
3. Flush the transmit FIFO by clearing bit 4 (FEN) in the line control register (**UARTLCRH**).
4. Reprogram the control register.
5. Enable the UART.

UART Control (UARTCTL)

UART0 base: 0x4000.C000
 UART1 base: 0x4000.D000
 UART2 base: 0x4000.E000
 UART3 base: 0x4000.F000
 UART4 base: 0x4001.0000
 UART5 base: 0x4001.1000
 UART6 base: 0x4001.2000
 UART7 base: 0x4001.3000
 Offset 0x030
 Type RW, reset 0x0000.0300

	31	30	29	28	27	26	25	24	23	22	21	20	19	18	17	16
	reserved															
Type	RO	RO	RO	RO	RO	RO	RO	RO	RO	RO	RO	RO	RO	RO	RO	RO
Reset	0	0	0	0	0	0	0	0	0	0	0	0	0	0	0	0
	15	14	13	12	11	10	9	8	7	6	5	4	3	2	1	0
	CTSEN	RTSEN	reserved	RTS	DTR	RXE	TXE	LBE	reserved	HSE	EOT	SMART	SIRLP	SIREN	UARTEN	
Type	RW	RW	RO	RO	RW	RW	RW	RW	RW	RO	RW	RW	RW	RW	RW	RW
Reset	0	0	0	0	0	0	1	1	0	0	0	0	0	0	0	0

Bit/Field	Name	Type	Reset	Description
31:16	reserved	RO	0x0000	Software should not rely on the value of a reserved bit. To provide compatibility with future products, the value of a reserved bit should be preserved across a read-modify-write operation.
15	CTSEN	RW	0	Enable Clear To Send Value Description 0 CTS hardware flow control is disabled. 1 CTS hardware flow control is enabled. Data is only transmitted when the $UnCTS$ signal is asserted.
14	RTSEN	RW	0	Enable Request to Send Value Description 0 RTS hardware flow control is disabled. 1 RTS hardware flow control is enabled. Data is only requested (by asserting $UnRTS$) when the receive FIFO has available entries.
13:12	reserved	RO	0	Software should not rely on the value of a reserved bit. To provide compatibility with future products, the value of a reserved bit should be preserved across a read-modify-write operation.
11	RTS	RW	0	Request to Send When $RTSEN$ is clear, the status of this bit is reflected on the $U1RTS$ signal. If $RTSEN$ is set, this bit is ignored on a write and should be ignored on read.
10	DTR	RW	0	Data Terminal Ready This bit sets the state of the $UnDTR$ output.
9	RXE	RW	1	UART Receive Enable Value Description 0 The receive section of the UART is disabled. 1 The receive section of the UART is enabled. If the UART is disabled in the middle of a receive, it completes the current character before stopping. Note: To enable reception, the $UARTEN$ bit must also be set.
8	TXE	RW	1	UART Transmit Enable Value Description 0 The transmit section of the UART is disabled. 1 The transmit section of the UART is enabled. If the UART is disabled in the middle of a transmission, it completes the current character before stopping. Note: To enable transmission, the $UARTEN$ bit must also be set.

Bit/Field	Name	Type	Reset	Description
7	LBE	RW	0	<p>UART Loop Back Enable</p> <p>Value Description</p> <p>0 Normal operation.</p> <p>1 The <code>UnTx</code> path is fed through the <code>UnRx</code> path.</p>
6	reserved	RO	0	Software should not rely on the value of a reserved bit. To provide compatibility with future products, the value of a reserved bit should be preserved across a read-modify-write operation.
5	HSE	RW	0	<p>High-Speed Enable</p> <p>Value Description</p> <p>0 The UART is clocked using the system clock divided by 16.</p> <p>1 The UART is clocked using the system clock divided by 8.</p> <p>Note: System clock used is also dependent on the baud-rate divisor configuration (see page 1308) and page 1309).</p> <p>The state of this bit has no effect on clock generation in ISO 7816 smart card mode (the <code>SMART</code> bit is set).</p>
4	EOT	RW	0	<p>End of Transmission</p> <p>This bit determines the behavior of the <code>TXRIS</code> bit in the <code>UARTRIS</code> register.</p> <p>Value Description</p> <p>0 The <code>TXRIS</code> bit is set when the transmit FIFO condition specified in <code>UARTIFLS</code> is met.</p> <p>1 The <code>TXRIS</code> bit is set only after all transmitted data, including stop bits, have cleared the serializer.</p>
3	SMART	RW	0	<p>ISO 7816 Smart Card Support</p> <p>Value Description</p> <p>0 Normal operation.</p> <p>1 The UART operates in Smart Card mode.</p> <p>The application must ensure that it sets 8-bit word length (<code>WLEN</code> set to 0x3) and even parity (<code>PEN</code> set to 1, <code>EPS</code> set to 1, <code>SPS</code> set to 0) in <code>UARTLCRH</code> when using ISO 7816 mode.</p> <p>In this mode, the value of the <code>STP2</code> bit in <code>UARTLCRH</code> is ignored and the number of stop bits is forced to 2. Note that the UART does not support automatic retransmission on parity errors. If a parity error is detected on transmission, all further transmit operations are aborted and software must handle retransmission of the affected byte or message.</p>

Bit/Field	Name	Type	Reset	Description
2	SIRLP	RW	0	<p>UART SIR Low-Power Mode</p> <p>This bit selects the IrDA encoding mode.</p> <p>Value Description</p> <p>0 Low-level bits are transmitted as an active High pulse with a width of 3/16th of the bit period.</p> <p>1 The UART operates in SIR Low-Power mode. Low-level bits are transmitted with a pulse width which is 3 times the period of the <code>IrLPBaud16</code> input signal, regardless of the selected bit rate.</p> <p>Setting this bit uses less power, but might reduce transmission distances. See page 1307 for more information.</p>
1	SIREN	RW	0	<p>UART SIR Enable</p> <p>Value Description</p> <p>0 Normal operation.</p> <p>1 The IrDA SIR block is enabled, and the UART will transmit and receive data using SIR protocol.</p>
0	UARTEN	RW	0	<p>UART Enable</p> <p>Value Description</p> <p>0 The UART is disabled.</p> <p>1 The UART is enabled.</p> <p>If the UART is disabled in the middle of transmission or reception, it completes the current character before stopping.</p>

Register 9: UART Interrupt FIFO Level Select (UARTIFLS), offset 0x034

The **UARTIFLS** register is the interrupt FIFO level select register. You can use this register to define the FIFO level at which the **TXRIS** and **RXRIS** bits in the **UARTRIS** register are triggered.

The interrupts are generated based on a transition through a level rather than being based on the level. That is, the interrupts are generated when the fill level progresses through the trigger level. For example, if the receive trigger level is set to the half-way mark, the interrupt is triggered as the module is receiving the 9th character.

Out of reset, the **TXIFLSEL** and **RXIFLSEL** bits are configured so that the FIFOs trigger an interrupt at the half-way mark.

UART Interrupt FIFO Level Select (UARTIFLS)

UART0 base: 0x4000.C000
 UART1 base: 0x4000.D000
 UART2 base: 0x4000.E000
 UART3 base: 0x4000.F000
 UART4 base: 0x4001.0000
 UART5 base: 0x4001.1000
 UART6 base: 0x4001.2000
 UART7 base: 0x4001.3000
 Offset 0x034
 Type RW, reset 0x0000.0012

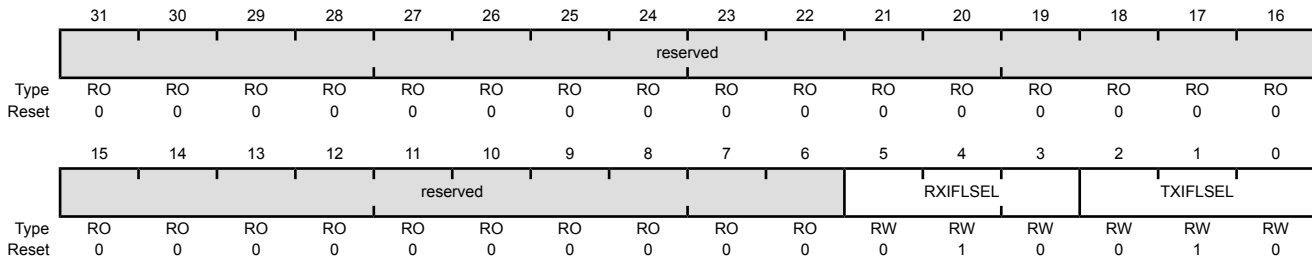

Bit/Field	Name	Type	Reset	Description														
31:6	reserved	RO	0x0000.00	Software should not rely on the value of a reserved bit. To provide compatibility with future products, the value of a reserved bit should be preserved across a read-modify-write operation.														
5:3	RXIFLSEL	RW	0x2	UART Receive Interrupt FIFO Level Select The trigger points for the receive interrupt are as follows: <table border="1"> <thead> <tr> <th>Value</th> <th>Description</th> </tr> </thead> <tbody> <tr> <td>0x0</td> <td>RX FIFO ≥ 1/8 full</td> </tr> <tr> <td>0x1</td> <td>RX FIFO ≥ 1/4 full</td> </tr> <tr> <td>0x2</td> <td>RX FIFO ≥ 1/2 full (default)</td> </tr> <tr> <td>0x3</td> <td>RX FIFO ≥ 3/4 full</td> </tr> <tr> <td>0x4</td> <td>RX FIFO ≥ 7/8 full</td> </tr> <tr> <td>0x5-0x7</td> <td>Reserved</td> </tr> </tbody> </table>	Value	Description	0x0	RX FIFO ≥ 1/8 full	0x1	RX FIFO ≥ 1/4 full	0x2	RX FIFO ≥ 1/2 full (default)	0x3	RX FIFO ≥ 3/4 full	0x4	RX FIFO ≥ 7/8 full	0x5-0x7	Reserved
Value	Description																	
0x0	RX FIFO ≥ 1/8 full																	
0x1	RX FIFO ≥ 1/4 full																	
0x2	RX FIFO ≥ 1/2 full (default)																	
0x3	RX FIFO ≥ 3/4 full																	
0x4	RX FIFO ≥ 7/8 full																	
0x5-0x7	Reserved																	

Bit/Field	Name	Type	Reset	Description
2:0	TXIFLSEL	RW	0x2	UART Transmit Interrupt FIFO Level Select The trigger points for the transmit interrupt are as follows: Value Description 0x0 TX FIFO \leq $\frac{7}{8}$ empty 0x1 TX FIFO \leq $\frac{3}{4}$ empty 0x2 TX FIFO \leq $\frac{1}{2}$ empty (default) 0x3 TX FIFO \leq $\frac{1}{4}$ empty 0x4 TX FIFO \leq $\frac{1}{8}$ empty 0x5-0x7 Reserved Note: If the EOT bit in UARTCTL is set (see page 1312), the transmit interrupt is generated once the FIFO is completely empty and all data including stop bits have left the transmit serializer. In this case, the setting of TXIFLSEL is ignored.

Register 10: UART Interrupt Mask (UARTIM), offset 0x038

The **UARTIM** register is the interrupt mask set/clear register.

On a read, this register gives the current value of the mask on the relevant interrupt. Setting a bit allows the corresponding raw interrupt signal to be routed to the interrupt controller. Clearing a bit prevents the raw interrupt signal from being sent to the interrupt controller.

Note: Registers that contain bits for modem control or status only apply to the following UARTs:

- UART0 (modem flow control and modem status)
- UART1 (modem flow control and modem status)
- UART2 (modem flow control)
- UART3 (modem flow control)
- UART4 (modem flow control)

UART Interrupt Mask (UARTIM)

UART0 base: 0x4000.C000
 UART1 base: 0x4000.D000
 UART2 base: 0x4000.E000
 UART3 base: 0x4000.F000
 UART4 base: 0x4001.0000
 UART5 base: 0x4001.1000
 UART6 base: 0x4001.2000
 UART7 base: 0x4001.3000
 Offset 0x038
 Type RW, reset 0x0000.0000

	31	30	29	28	27	26	25	24	23	22	21	20	19	18	17	16
	reserved														DMATXIM	DMARXIM
Type	RO	RO	RO	RO	RO	RO	RO	RO	RO	RO	RO	RO	RO	RO	RW	RW
Reset	0	0	0	0	0	0	0	0	0	0	0	0	0	0	0	0
	15	14	13	12	11	10	9	8	7	6	5	4	3	2	1	0
	reserved			9BITIM	EOTIM	OEIM	BEIM	PEIM	FEIM	RTIM	TXIM	RXIM	DSRIM	DCDIM	CTSIM	RIIM
Type	RO	RO	RO	RW	RW	RW	RW	RW	RW	RW	RW	RW	RW	RW	RW	RW
Reset	0	0	0	0	0	0	0	0	0	0	0	0	0	0	0	0

Bit/Field	Name	Type	Reset	Description	
31:18	reserved	RO	0	Software should not rely on the value of a reserved bit. To provide compatibility with future products, the value of a reserved bit should be preserved across a read-modify-write operation.	
17	DMATXIM	RW	0	Transmit DMA Interrupt Mask	
Value Description					
	0	The DMATXRIS interrupt is suppressed and not sent to the interrupt controller.			
	1	An interrupt is sent to the interrupt controller when the DMATXRIS bit in the UARTRIS register is set.			

Bit/Field	Name	Type	Reset	Description
16	DMARXIM	RW	0	Receive DMA Interrupt Mask Value Description 0 The DMARXRIS interrupt is suppressed and not sent to the interrupt controller. 1 An interrupt is sent to the interrupt controller when the DMARXRIS bit in the UARTRIS register is set.
15:13	reserved	RO	0	Software should not rely on the value of a reserved bit. To provide compatibility with future products, the value of a reserved bit should be preserved across a read-modify-write operation.
12	9BITIM	RW	0	9-Bit Mode Interrupt Mask Value Description 0 The 9BITRIS interrupt is suppressed and not sent to the interrupt controller. 1 An interrupt is sent to the interrupt controller when the 9BITRIS bit in the UARTRIS register is set.
11	EOTIM	RW	0	End of Transmission Interrupt Mask Value Description 0 The EOTRIS interrupt is suppressed and not sent to the interrupt controller. 1 An interrupt is sent to the interrupt controller when the EOTRIS bit in the UARTRIS register is set.
10	OEIM	RW	0	UART Overrun Error Interrupt Mask Value Description 0 The OERIS interrupt is suppressed and not sent to the interrupt controller. 1 An interrupt is sent to the interrupt controller when the OERIS bit in the UARTRIS register is set.
9	BEIM	RW	0	UART Break Error Interrupt Mask Value Description 0 The BERIS interrupt is suppressed and not sent to the interrupt controller. 1 An interrupt is sent to the interrupt controller when the BERIS bit in the UARTRIS register is set.

Bit/Field	Name	Type	Reset	Description
8	PEIM	RW	0	<p>UART Parity Error Interrupt Mask</p> <p>Value Description</p> <p>0 The <code>PERIS</code> interrupt is suppressed and not sent to the interrupt controller.</p> <p>1 An interrupt is sent to the interrupt controller when the <code>PERIS</code> bit in the UARTRIS register is set.</p>
7	FEIM	RW	0	<p>UART Framing Error Interrupt Mask</p> <p>Value Description</p> <p>0 The <code>FERIS</code> interrupt is suppressed and not sent to the interrupt controller.</p> <p>1 An interrupt is sent to the interrupt controller when the <code>FERIS</code> bit in the UARTRIS register is set.</p>
6	RTIM	RW	0	<p>UART Receive Time-Out Interrupt Mask</p> <p>Value Description</p> <p>0 The <code>RTRIS</code> interrupt is suppressed and not sent to the interrupt controller.</p> <p>1 An interrupt is sent to the interrupt controller when the <code>RTRIS</code> bit in the UARTRIS register is set.</p>
5	TXIM	RW	0	<p>UART Transmit Interrupt Mask</p> <p>Value Description</p> <p>0 The <code>TXRIS</code> interrupt is suppressed and not sent to the interrupt controller.</p> <p>1 An interrupt is sent to the interrupt controller when the <code>TXRIS</code> bit in the UARTRIS register is set.</p>
4	RXIM	RW	0	<p>UART Receive Interrupt Mask</p> <p>Value Description</p> <p>0 The <code>RXRIS</code> interrupt is suppressed and not sent to the interrupt controller.</p> <p>1 An interrupt is sent to the interrupt controller when the <code>RXRIS</code> bit in the UARTRIS register is set.</p>
3	DSRIM	RW	0	<p>UART Data Set Ready Modem Interrupt Mask</p> <p>Value Description</p> <p>0 The <code>DSRRIS</code> interrupt is suppressed and not sent to the interrupt controller.</p> <p>1 An interrupt is sent to the interrupt controller when the <code>DSRRIS</code> bit in the UARTRIS register is set.</p>

Bit/Field	Name	Type	Reset	Description
2	DCDIM	RW	0	UART Data Carrier Detect Modem Interrupt Mask Value Description 0 The DCDRIS interrupt is suppressed and not sent to the interrupt controller. 1 An interrupt is sent to the interrupt controller when the DCDRIS bit in the UARTRIS register is set.
1	CTSIM	RW	0	UART Clear to Send Modem Interrupt Mask Value Description 0 The CTSRIS interrupt is suppressed and not sent to the interrupt controller. 1 An interrupt is sent to the interrupt controller when the CTSRIS bit in the UARTRIS register is set.
0	RIIM	RW	0	UART Ring Indicator Modem Interrupt Mask Value Description 0 The RIRIS interrupt is suppressed and not sent to the interrupt controller. 1 An interrupt is sent to the interrupt controller when the RIRIS bit in the UARTRIS register is set.

Register 11: UART Raw Interrupt Status (UARTRIS), offset 0x03C

The **UARTRIS** register is the raw interrupt status register. On a read, this register gives the current raw status value of the corresponding interrupt. A write has no effect.

UART Raw Interrupt Status (UARTRIS)

UART0 base: 0x4000.C000
 UART1 base: 0x4000.D000
 UART2 base: 0x4000.E000
 UART3 base: 0x4000.F000
 UART4 base: 0x4001.0000
 UART5 base: 0x4001.1000
 UART6 base: 0x4001.2000
 UART7 base: 0x4001.3000
 Offset 0x03C
 Type RO, reset 0x0000.0000

	31	30	29	28	27	26	25	24	23	22	21	20	19	18	17	16
	reserved														DMATXRIS	DMARXRIS
Type	RO	RO	RO	RO	RO	RO	RO	RO	RO	RO	RO	RO	RO	RO	RO	RO
Reset	0	0	0	0	0	0	0	0	0	0	0	0	0	0	0	0
	15	14	13	12	11	10	9	8	7	6	5	4	3	2	1	0
	reserved			9BITRIS	EOTRIS	OERIS	BERIS	PERIS	FERIS	RTRIS	TXRIS	RXRIS	DSRRIS	DCDRIS	CTSRIS	RIRIS
Type	RO	RO	RO	RO	RO	RO	RO	RO	RO	RO	RO	RO	RO	RO	RO	RO
Reset	0	0	0	0	0	0	0	0	0	0	0	0	0	0	0	0

Bit/Field	Name	Type	Reset	Description
31:18	reserved	RO	0	Software should not rely on the value of a reserved bit. To provide compatibility with future products, the value of a reserved bit should be preserved across a read-modify-write operation.
17	DMATXRIS	RO	0	Transmit DMA Raw Interrupt Status Value Description 0 No interrupt 1 The transmit DMA has completed. This bit is cleared by writing a 1 to the DMATXIC bit in the UARTICR register.
16	DMARXRIS	RO	0	Receive DMA Raw Interrupt Status Value Description 0 No interrupt 1 The receive DMA has completed. This bit is cleared by writing a 1 to the DMARXIC bit in the UARTICR register.
15:13	reserved	RO	0	Software should not rely on the value of a reserved bit. To provide compatibility with future products, the value of a reserved bit should be preserved across a read-modify-write operation.

Bit/Field	Name	Type	Reset	Description
12	9BITRIS	RO	0	<p>9-Bit Mode Raw Interrupt Status</p> <p>Value Description</p> <p>0 No interrupt</p> <p>1 A receive address match has occurred.</p> <p>This bit is cleared by writing a 1 to the 9BITIC bit in the UARTICR register.</p>
11	EOTRIS	RO	0	<p>End of Transmission Raw Interrupt Status</p> <p>Value Description</p> <p>0 No interrupt</p> <p>1 The last bit of all transmitted data and flags has left the serializer.</p> <p>This bit is cleared by writing a 1 to the EOTIC bit in the UARTICR register.</p>
10	OERIS	RO	0	<p>UART Overrun Error Raw Interrupt Status</p> <p>Value Description</p> <p>0 No interrupt</p> <p>1 An overrun error has occurred.</p> <p>This bit is cleared by writing a 1 to the OEIC bit in the UARTICR register.</p>
9	BERIS	RO	0	<p>UART Break Error Raw Interrupt Status</p> <p>Value Description</p> <p>0 No interrupt</p> <p>1 A break error has occurred.</p> <p>This bit is cleared by writing a 1 to the BEIC bit in the UARTICR register.</p>
8	PERIS	RO	0	<p>UART Parity Error Raw Interrupt Status</p> <p>Value Description</p> <p>0 No interrupt</p> <p>1 A parity error has occurred.</p> <p>This bit is cleared by writing a 1 to the PEIC bit in the UARTICR register.</p>
7	FERIS	RO	0	<p>UART Framing Error Raw Interrupt Status</p> <p>Value Description</p> <p>0 No interrupt</p> <p>1 A framing error has occurred.</p> <p>This bit is cleared by writing a 1 to the FEIC bit in the UARTICR register.</p>

Bit/Field	Name	Type	Reset	Description
6	RTRIS	RO	0	<p>UART Receive Time-Out Raw Interrupt Status</p> <p>Value Description</p> <p>0 No interrupt</p> <p>1 A receive time out has occurred.</p> <p>This bit is cleared by writing a 1 to the RTIC bit in the UARTICR register. For receive timeout, the RTIM bit in the UARTIM register must be set to see the RTRIS status.</p>
5	TXRIS	RO	0	<p>UART Transmit Raw Interrupt Status</p> <p>Value Description</p> <p>0 No interrupt</p> <p>1 If the EOT bit in the UARTCTL register is clear, the transmit FIFO level has passed through the condition defined in the UARTIFLS register.</p> <p>If the EOT bit is set, the last bit of all transmitted data and flags has left the serializer.</p> <p>This bit is cleared by writing a 1 to the TXIC bit in the UARTICR register or by writing data to the transmit FIFO until it becomes greater than the trigger level, if the FIFO is enabled, or by writing a single byte if the FIFO is disabled.</p>
4	RXRIS	RO	0	<p>UART Receive Raw Interrupt Status</p> <p>Value Description</p> <p>0 No interrupt</p> <p>1 The receive FIFO level has passed through the condition defined in the UARTIFLS register.</p> <p>This bit is cleared by writing a 1 to the RXIC bit in the UARTICR register or by reading data from the receive FIFO until it becomes less than the trigger level, if the FIFO is enabled, or by reading a single byte if the FIFO is disabled.</p>
3	DSRRIS	RO	0	<p>UART Data Set Ready Modem Raw Interrupt Status</p> <p>Value Description</p> <p>0 No interrupt</p> <p>1 Data Set Ready used for software flow control.</p> <p>This bit is cleared by writing a 1 to the DSRIC bit in the UARTICR register.</p>
2	DCDRIS	RO	0	<p>UART Data Carrier Detect Modem Raw Interrupt Status</p> <p>Value Description</p> <p>0 No interrupt</p> <p>1 Data Carrier Detect used for software flow control.</p> <p>This bit is cleared by writing a 1 to the DCDIC bit in the UARTICR register.</p>

Bit/Field	Name	Type	Reset	Description
1	CTSRIS	RO	0	UART Clear to Send Modem Raw Interrupt Status Value Description 0 No interrupt 1 Clear to Send used for software flow control. This bit is cleared by writing a 1 to the <code>CTSIC</code> bit in the UARTICR register.
0	RIRIS	RO	0	UART Ring Indicator Modem Raw Interrupt Status Value Description 0 No interrupt 1 Ring Indicator used for software flow control. This bit is cleared by writing a 1 to the <code>RIIC</code> bit in the UARTICR register.

Register 12: UART Masked Interrupt Status (UARTMIS), offset 0x040

The **UARTMIS** register is the masked interrupt status register. On a read, this register gives the current masked status value of the corresponding interrupt. A write has no effect.

UART Masked Interrupt Status (UARTMIS)

UART0 base: 0x4000.C000
 UART1 base: 0x4000.D000
 UART2 base: 0x4000.E000
 UART3 base: 0x4000.F000
 UART4 base: 0x4001.0000
 UART5 base: 0x4001.1000
 UART6 base: 0x4001.2000
 UART7 base: 0x4001.3000
 Offset 0x040
 Type RO, reset 0x0000.0000

	31	30	29	28	27	26	25	24	23	22	21	20	19	18	17	16
	reserved														DMATXMIS	DMARXMIS
Type	RO	RO	RO	RO	RO	RO	RO	RO	RO	RO	RO	RO	RO	RO	RO	RO
Reset	0	0	0	0	0	0	0	0	0	0	0	0	0	0	0	0
	15	14	13	12	11	10	9	8	7	6	5	4	3	2	1	0
	reserved			9BITMIS	EOTMIS	OEMIS	BEMIS	PEMIS	FEMIS	RTMIS	TXMIS	RXMIS	DSRMIS	DCDMIS	CTSMIS	RIMIS
Type	RO	RO	RO	RO	RO	RO	RO	RO	RO	RO	RO	RO	RO	RO	RO	RO
Reset	0	0	0	0	0	0	0	0	0	0	0	0	0	0	0	0

Bit/Field	Name	Type	Reset	Description
31:18	reserved	RO	0	Software should not rely on the value of a reserved bit. To provide compatibility with future products, the value of a reserved bit should be preserved across a read-modify-write operation.
17	DMATXMIS	RO	0	Transmit DMA Masked Interrupt Status Value Description 0 An interrupt has not occurred or is masked. 1 An unmasked interrupt was signaled due to the completion of the transmit DMA. This bit is cleared by writing a 1 to the DMATXIC bit in the UARTICR register.
16	DMARXMIS	RO	0	Receive DMA Masked Interrupt Status Value Description 0 An interrupt has not occurred or is masked. 1 An unmasked interrupt was signaled due to the completion of the receive DMA. This bit is cleared by writing a 1 to the DMARXIC bit in the UARTICR register.
15:13	reserved	RO	0	Software should not rely on the value of a reserved bit. To provide compatibility with future products, the value of a reserved bit should be preserved across a read-modify-write operation.

Bit/Field	Name	Type	Reset	Description
12	9BITMIS	RO	0	<p>9-Bit Mode Masked Interrupt Status</p> <p>Value Description</p> <p>0 An interrupt has not occurred or is masked.</p> <p>1 An unmasked interrupt was signaled due to a receive address match.</p> <p>This bit is cleared by writing a 1 to the 9BITIC bit in the UARTICR register.</p>
11	EOTMIS	RO	0	<p>End of Transmission Masked Interrupt Status</p> <p>Value Description</p> <p>0 An interrupt has not occurred or is masked.</p> <p>1 An unmasked interrupt was signaled due to the transmission of the last data bit.</p> <p>This bit is cleared by writing a 1 to the EOTIC bit in the UARTICR register.</p>
10	OEMIS	RO	0	<p>UART Overrun Error Masked Interrupt Status</p> <p>Value Description</p> <p>0 An interrupt has not occurred or is masked.</p> <p>1 An unmasked interrupt was signaled due to an overrun error.</p> <p>This bit is cleared by writing a 1 to the OEIC bit in the UARTICR register.</p>
9	BEMIS	RO	0	<p>UART Break Error Masked Interrupt Status</p> <p>Value Description</p> <p>0 An interrupt has not occurred or is masked.</p> <p>1 An unmasked interrupt was signaled due to a break error.</p> <p>This bit is cleared by writing a 1 to the BEIC bit in the UARTICR register.</p>
8	PEMIS	RO	0	<p>UART Parity Error Masked Interrupt Status</p> <p>Value Description</p> <p>0 An interrupt has not occurred or is masked.</p> <p>1 An unmasked interrupt was signaled due to a parity error.</p> <p>This bit is cleared by writing a 1 to the PEIC bit in the UARTICR register.</p>
7	FEMIS	RO	0	<p>UART Framing Error Masked Interrupt Status</p> <p>Value Description</p> <p>0 An interrupt has not occurred or is masked.</p> <p>1 An unmasked interrupt was signaled due to a framing error.</p> <p>This bit is cleared by writing a 1 to the FEIC bit in the UARTICR register.</p>

Bit/Field	Name	Type	Reset	Description
6	RTMIS	RO	0	<p>UART Receive Time-Out Masked Interrupt Status</p> <p>Value Description</p> <p>0 An interrupt has not occurred or is masked.</p> <p>1 An unmasked interrupt was signaled due to a receive time out.</p> <p>This bit is cleared by writing a 1 to the RTIC bit in the UARTICR register. For receive timeout, the RTIM bit in the UARTIM register must be set to see the RTMIS status.</p>
5	TXMIS	RO	0	<p>UART Transmit Masked Interrupt Status</p> <p>Value Description</p> <p>0 An interrupt has not occurred or is masked.</p> <p>1 An unmasked interrupt was signaled due to passing through the specified transmit FIFO level (if the EOT bit is clear) or due to the transmission of the last data bit (if the EOT bit is set).</p> <p>This bit is cleared by writing a 1 to the TXIC bit in the UARTICR register or by writing data to the transmit FIFO until it becomes greater than the trigger level, if the FIFO is enabled, or by writing a single byte if the FIFO is disabled.</p>
4	RXMIS	RO	0	<p>UART Receive Masked Interrupt Status</p> <p>Value Description</p> <p>0 An interrupt has not occurred or is masked.</p> <p>1 An unmasked interrupt was signaled due to passing through the specified receive FIFO level.</p> <p>This bit is cleared by writing a 1 to the RXIC bit in the UARTICR register or by reading data from the receive FIFO until it becomes less than the trigger level, if the FIFO is enabled, or by reading a single byte if the FIFO is disabled.</p>
3	DSRMIS	RO	0	<p>UART Data Set Ready Modem Masked Interrupt Status</p> <p>Value Description</p> <p>0 An interrupt has not occurred or is masked.</p> <p>1 An unmasked interrupt was signaled due to Data Set Ready.</p> <p>This bit is cleared by writing a 1 to the DSRIC bit in the UARTICR register.</p>
2	DCDMIS	RO	0	<p>UART Data Carrier Detect Modem Masked Interrupt Status</p> <p>Value Description</p> <p>0 An interrupt has not occurred or is masked.</p> <p>1 An unmasked interrupt was signaled due to Data Carrier Detect.</p> <p>This bit is cleared by writing a 1 to the DCDIC bit in the UARTICR register.</p>

Bit/Field	Name	Type	Reset	Description
1	CTSMIS	RO	0	UART Clear to Send Modem Masked Interrupt Status Value Description 0 An interrupt has not occurred or is masked. 1 An unmasked interrupt was signaled due to Clear to Send. This bit is cleared by writing a 1 to the CTSIC bit in the UARTICR register.
0	RIMIS	RO	0	UART Ring Indicator Modem Masked Interrupt Status Value Description 0 An interrupt has not occurred or is masked. 1 An unmasked interrupt was signaled due to Ring Indicator. This bit is cleared by writing a 1 to the RIIC bit in the UARTICR register.

Register 13: UART Interrupt Clear (UARTICR), offset 0x044

The **UARTICR** register is the interrupt clear register. On a write of 1, the corresponding interrupt (both raw interrupt and masked interrupt, if enabled) is cleared. A write of 0 has no effect.

Note that bits [3:0] are only implemented on UART1. These bits are reserved on UART0 and UART2.

UART Interrupt Clear (UARTICR)

UART0 base: 0x4000.C000
 UART1 base: 0x4000.D000
 UART2 base: 0x4000.E000
 UART3 base: 0x4000.F000
 UART4 base: 0x4001.0000
 UART5 base: 0x4001.1000
 UART6 base: 0x4001.2000
 UART7 base: 0x4001.3000
 Offset 0x044
 Type W1C, reset 0x0000.0000

	31	30	29	28	27	26	25	24	23	22	21	20	19	18	17	16
	reserved														DMATXIC	DMARXIC
Type	RO	RO	RO	RO	RO	RO	RO	RO	RO	RO	RO	RO	RO	RO	W1C	W1C
Reset	0	0	0	0	0	0	0	0	0	0	0	0	0	0	0	0
	15	14	13	12	11	10	9	8	7	6	5	4	3	2	1	0
	reserved			9BITIC	EOTIC	OEIC	BEIC	PEIC	FEIC	RTIC	TXIC	RXIC	DSRMIC	DCDMIC	CTSMIC	RIMIC
Type	RO	RO	RO	RW	W1C	W1C	W1C	W1C	W1C	W1C	W1C	W1C	W1C	W1C	W1C	W1C
Reset	0	0	0	0	0	0	0	0	0	0	0	0	0	0	0	0

Bit/Field	Name	Type	Reset	Description
31:18	reserved	RO	0	Software should not rely on the value of a reserved bit. To provide compatibility with future products, the value of a reserved bit should be preserved across a read-modify-write operation.
17	DMATXIC	W1C	0	Transmit DMA Interrupt Clear Writing a 1 to this bit clears the DMATXRIS bit in the UARTRIS register and the DMATXMIS bit in the UARTMIS register.
16	DMARXIC	W1C	0	Receive DMA Interrupt Clear Writing a 1 to this bit clears the DMARXRIS bit in the UARTRIS register and the DMARXMIS bit in the UARTMIS register.
15:13	reserved	RO	0	Software should not rely on the value of a reserved bit. To provide compatibility with future products, the value of a reserved bit should be preserved across a read-modify-write operation.
12	9BITIC	RW	0	9-Bit Mode Interrupt Clear Writing a 1 to this bit clears the 9BITRIS bit in the UARTRIS register and the 9BITMIS bit in the UARTMIS register.
11	EOTIC	W1C	0	End of Transmission Interrupt Clear Writing a 1 to this bit clears the EOTRIS bit in the UARTRIS register and the EOTMIS bit in the UARTMIS register.
10	OEIC	W1C	0	Overrun Error Interrupt Clear Writing a 1 to this bit clears the OERIS bit in the UARTRIS register and the OEMIS bit in the UARTMIS register.

Bit/Field	Name	Type	Reset	Description
9	BEIC	W1C	0	Break Error Interrupt Clear Writing a 1 to this bit clears the BERIS bit in the UARTRIS register and the BEMIS bit in the UARTMIS register.
8	PEIC	W1C	0	Parity Error Interrupt Clear Writing a 1 to this bit clears the PERIS bit in the UARTRIS register and the PEMIS bit in the UARTMIS register.
7	FEIC	W1C	0	Framing Error Interrupt Clear Writing a 1 to this bit clears the FERIS bit in the UARTRIS register and the FEMIS bit in the UARTMIS register.
6	RTIC	W1C	0	Receive Time-Out Interrupt Clear Writing a 1 to this bit clears the RTRIS bit in the UARTRIS register and the RTMIS bit in the UARTMIS register.
5	TXIC	W1C	0	Transmit Interrupt Clear Writing a 1 to this bit clears the TXRIS bit in the UARTRIS register and the TXMIS bit in the UARTMIS register.
4	RXIC	W1C	0	Receive Interrupt Clear Writing a 1 to this bit clears the RXRIS bit in the UARTRIS register and the RXMIS bit in the UARTMIS register.
3	DSRMIC	W1C	0	UART Data Set Ready Modem Interrupt Clear Writing a 1 to this bit clears the DSRRIS bit in the UARTRIS register and the DSRMIS bit in the UARTMIS register.
2	DCDMIC	W1C	0	UART Data Carrier Detect Modem Interrupt Clear Writing a 1 to this bit clears the DCDRIS bit in the UARTRIS register and the DCDMIS bit in the UARTMIS register.
1	CTSMIC	W1C	0	UART Clear to Send Modem Interrupt Clear Writing a 1 to this bit clears the CTSRIS bit in the UARTRIS register and the CTSMIS bit in the UARTMIS register.
0	RIMIC	W1C	0	UART Ring Indicator Modem Interrupt Clear Writing a 1 to this bit clears the RIRIS bit in the UARTRIS register and the RIMIS bit in the UARTMIS register.

Register 14: UART DMA Control (UARTDMACTL), offset 0x048

The **UARTDMACTL** register is the DMA control register.

UART DMA Control (UARTDMACTL)

UART0 base: 0x4000.C000
 UART1 base: 0x4000.D000
 UART2 base: 0x4000.E000
 UART3 base: 0x4000.F000
 UART4 base: 0x4001.0000
 UART5 base: 0x4001.1000
 UART6 base: 0x4001.2000
 UART7 base: 0x4001.3000
 Offset 0x048
 Type RW, reset 0x0000.0000

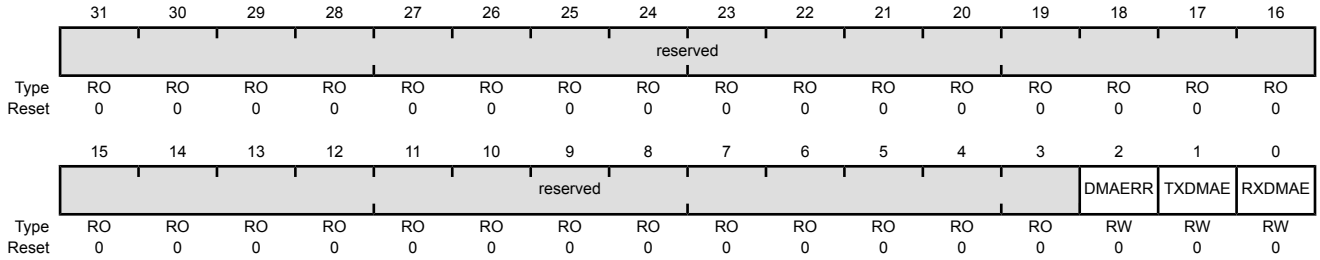

Bit/Field	Name	Type	Reset	Description
31:3	reserved	RO	0x00000.000	Software should not rely on the value of a reserved bit. To provide compatibility with future products, the value of a reserved bit should be preserved across a read-modify-write operation.
2	DMAERR	RW	0	DMA on Error Value Description 0 μDMA receive requests are unaffected when a receive error occurs. 1 μDMA receive requests are automatically disabled when a receive error occurs.
1	TXDMAE	RW	0	Transmit DMA Enable Value Description 0 μDMA for the transmit FIFO is disabled. 1 μDMA for the transmit FIFO is enabled.
0	RXDMAE	RW	0	Receive DMA Enable Value Description 0 μDMA for the receive FIFO is disabled. 1 μDMA for the receive FIFO is enabled.

Register 15: UART 9-Bit Self Address (UART9BITADDR), offset 0x0A4

The **UART9BITADDR** register is used to write the specific address that should be matched with the receiving byte when the 9-bit Address Mask (**UART9BITAMASK**) is set to 0xFF. This register is used in conjunction with **UART9BITAMASK** to form a match for address-byte received.

UART 9-Bit Self Address (UART9BITADDR)

UART0 base: 0x4000.C000
 UART1 base: 0x4000.D000
 UART2 base: 0x4000.E000
 UART3 base: 0x4000.F000
 UART4 base: 0x4001.0000
 UART5 base: 0x4001.1000
 UART6 base: 0x4001.2000
 UART7 base: 0x4001.3000
 Offset 0x0A4
 Type RW, reset 0x0000.0000

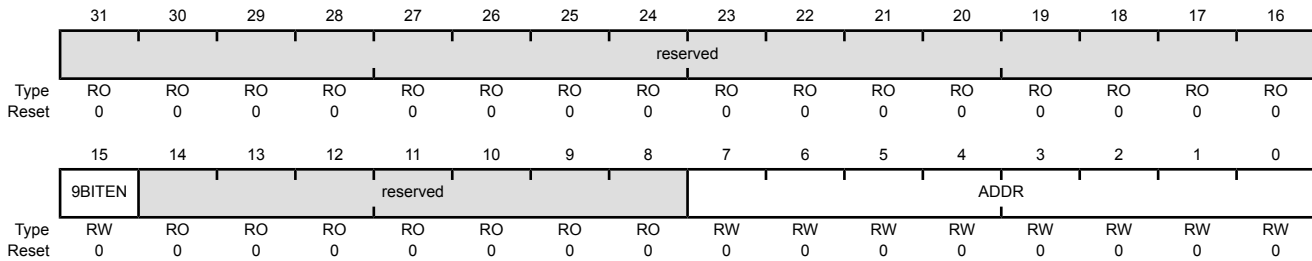

Bit/Field	Name	Type	Reset	Description
31:16	reserved	RO	0x0000	Software should not rely on the value of a reserved bit. To provide compatibility with future products, the value of a reserved bit should be preserved across a read-modify-write operation.
15	9BITEN	RW	0	Enable 9-Bit Mode Value Description 0 9-bit mode is disabled. 1 9-bit mode is enabled.
14:8	reserved	RO	0x0	Software should not rely on the value of a reserved bit. To provide compatibility with future products, the value of a reserved bit should be preserved across a read-modify-write operation.
7:0	ADDR	RW	0x00	Self Address for 9-Bit Mode This field contains the address that should be matched when UART9BITAMASK is 0xFF.

Register 16: UART 9-Bit Self Address Mask (UART9BITAMASK), offset 0x0A8

The **UART9BITAMASK** register is used to enable the address mask for 9-bit mode. The address bits are masked to create a set of addresses to be matched with the received address byte.

UART 9-Bit Self Address Mask (UART9BITAMASK)

UART0 base: 0x4000.C000
 UART1 base: 0x4000.D000
 UART2 base: 0x4000.E000
 UART3 base: 0x4000.F000
 UART4 base: 0x4001.0000
 UART5 base: 0x4001.1000
 UART6 base: 0x4001.2000
 UART7 base: 0x4001.3000
 Offset 0x0A8
 Type RW, reset 0x0000.00FF

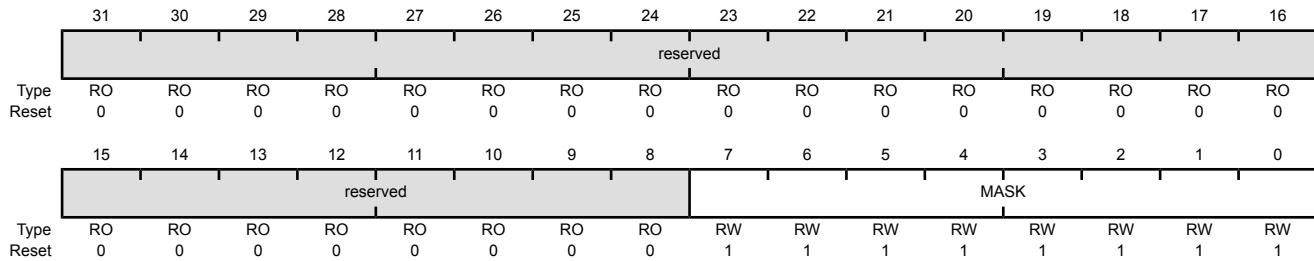

Bit/Field	Name	Type	Reset	Description
31:8	reserved	RO	0x00	Software should not rely on the value of a reserved bit. To provide compatibility with future products, the value of a reserved bit should be preserved across a read-modify-write operation.
7:0	MASK	RW	0xFF	Self Address Mask for 9-Bit Mode This field contains the address mask that creates a set of addresses that should be matched.

Register 17: UART Peripheral Properties (UARTPP), offset 0xFC0

The **UARTPP** register provides information regarding the properties of the UART module.

UART Peripheral Properties (UARTPP)

UART0 base: 0x4000.C000
 UART1 base: 0x4000.D000
 UART2 base: 0x4000.E000
 UART3 base: 0x4000.F000
 UART4 base: 0x4001.0000
 UART5 base: 0x4001.1000
 UART6 base: 0x4001.2000
 UART7 base: 0x4001.3000
 Offset 0xFC0
 Type RO, reset 0x0000.000F

	31	30	29	28	27	26	25	24	23	22	21	20	19	18	17	16	
	reserved																
Type	RO	RO	RO	RO	RO	RO	RO	RO	RO	RO	RO	RO	RO	RO	RO	RO	
Reset	0	0	0	0	0	0	0	0	0	0	0	0	0	0	0	0	
	15	14	13	12	11	10	9	8	7	6	5	4	3	2	1	0	
	reserved													MSE	MS	NB	SC
Type	RO	RO	RO	RO	RO	RO	RO	RO	RO	RO	RO	RO	RO	RO	RO	RO	
Reset	0	0	0	0	0	0	0	0	0	0	0	0	0	1	1	1	1

Bit/Field	Name	Type	Reset	Description
31:4	reserved	RO	0x0	Software should not rely on the value of a reserved bit. To provide compatibility with future products, the value of a reserved bit should be preserved across a read-modify-write operation.
3	MSE	RO	0x1	Modem Support Extended Value Description 0 The UART module does not provide extended support for modem control. 1 The UART module provides extended support for modem control including UARTnDTR, UARTnDSR, UARTnDCD, and UARTnRI.
2	MS	RO	0x1	Modem Support Value Description 0 The UART module does not provide support for modem control. 1 The UART module provides support for modem control including UARTnRTS and UARTnCTS.
1	NB	RO	0x1	9-Bit Support Value Description 0 The UART module does not provide support for the transmission of 9-bit data for RS-485 support. 1 The UART module provides support for the transmission of 9-bit data for RS-485 support.

Bit/Field	Name	Type	Reset	Description
0	SC	RO	0x1	Smart Card Support
				Value Description
				0 The UART module does not provide smart card support.
				1 The UART module provides smart card support.

Register 18: UART Clock Configuration (UARTCC), offset 0xFC8

The **UARTCC** register controls the baud clock source for the UART module. For more information, see the section called “Peripheral Clock Sources” on page 241.

Note: If the PIOSC is used for the UART baud clock, the system clock frequency must be at least 9 MHz in Run mode.

UART Clock Configuration (UARTCC)

UART0 base: 0x4000.C000
 UART1 base: 0x4000.D000
 UART2 base: 0x4000.E000
 UART3 base: 0x4000.F000
 UART4 base: 0x4001.0000
 UART5 base: 0x4001.1000
 UART6 base: 0x4001.2000
 UART7 base: 0x4001.3000
 Offset 0xFC8
 Type RW, reset 0x0000.0000

	31	30	29	28	27	26	25	24	23	22	21	20	19	18	17	16
	reserved															
Type	RO	RO	RO	RO	RO	RO	RO	RO	RO	RO	RO	RO	RO	RO	RO	RO
Reset	0	0	0	0	0	0	0	0	0	0	0	0	0	0	0	0
	15	14	13	12	11	10	9	8	7	6	5	4	3	2	1	0
	reserved												CS			
Type	RO	RO	RO	RO	RO	RO	RO	RO	RO	RO	RO	RO	RW	RW	RW	RW
Reset	0	0	0	0	0	0	0	0	0	0	0	0	0	0	0	0

Bit/Field	Name	Type	Reset	Description
31:4	reserved	RO	0x0000.000	Software should not rely on the value of a reserved bit. To provide compatibility with future products, the value of a reserved bit should be preserved across a read-modify-write operation.
3:0	CS	RW	0	UART Baud Clock Source The following table specifies the source that generates for the UART baud clock:
	Value	Description		
	0x0	System clock (based on clock source and divisor factor programmed in RSCLKCFG register in the System Control Module)		
	0x1-0x4	reserved		
	0x5	Alternate clock source as defined by ALTCLKCFG register in System Control Module.		
	0x5-0xF	Reserved		

Register 19: UART Peripheral Identification 4 (UARTPeriphID4), offset 0xFD0

The **UARTPeriphIDn** registers are hard-coded and the fields within the registers determine the reset values.

UART Peripheral Identification 4 (UARTPeriphID4)

UART0 base: 0x4000.C000
 UART1 base: 0x4000.D000
 UART2 base: 0x4000.E000
 UART3 base: 0x4000.F000
 UART4 base: 0x4001.0000
 UART5 base: 0x4001.1000
 UART6 base: 0x4001.2000
 UART7 base: 0x4001.3000
 Offset 0xFD0
 Type RO, reset 0x0000.0060

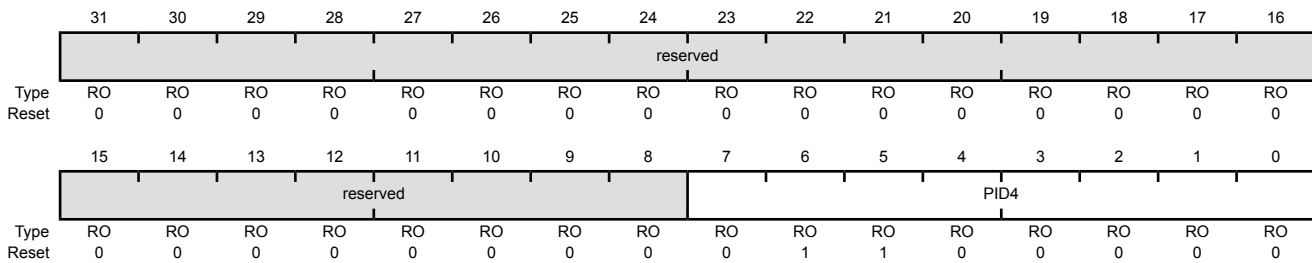

Bit/Field	Name	Type	Reset	Description
31:8	reserved	RO	0x0000.00	Software should not rely on the value of a reserved bit. To provide compatibility with future products, the value of a reserved bit should be preserved across a read-modify-write operation.
7:0	PID4	RO	0x60	UART Peripheral ID Register [7:0] Can be used by software to identify the presence of this peripheral.

Register 20: UART Peripheral Identification 5 (UARTPeriphID5), offset 0xFD4

The **UARTPeriphIDn** registers are hard-coded and the fields within the registers determine the reset values.

UART Peripheral Identification 5 (UARTPeriphID5)

UART0 base: 0x4000.C000
 UART1 base: 0x4000.D000
 UART2 base: 0x4000.E000
 UART3 base: 0x4000.F000
 UART4 base: 0x4001.0000
 UART5 base: 0x4001.1000
 UART6 base: 0x4001.2000
 UART7 base: 0x4001.3000
 Offset 0xFD4
 Type RO, reset 0x0000.0000

	31	30	29	28	27	26	25	24	23	22	21	20	19	18	17	16
	reserved															
Type	RO	RO	RO	RO	RO	RO	RO	RO	RO	RO	RO	RO	RO	RO	RO	RO
Reset	0	0	0	0	0	0	0	0	0	0	0	0	0	0	0	0
	15	14	13	12	11	10	9	8	7	6	5	4	3	2	1	0
	reserved								PID5							
Type	RO	RO	RO	RO	RO	RO	RO	RO	RO	RO	RO	RO	RO	RO	RO	RO
Reset	0	0	0	0	0	0	0	0	0	0	0	0	0	0	0	0

Bit/Field	Name	Type	Reset	Description
31:8	reserved	RO	0x0000.00	Software should not rely on the value of a reserved bit. To provide compatibility with future products, the value of a reserved bit should be preserved across a read-modify-write operation.
7:0	PID5	RO	0x00	UART Peripheral ID Register [15:8] Can be used by software to identify the presence of this peripheral.

Register 21: UART Peripheral Identification 6 (UARTPeriphID6), offset 0xFD8

The **UARTPeriphIDn** registers are hard-coded and the fields within the registers determine the reset values.

UART Peripheral Identification 6 (UARTPeriphID6)

UART0 base: 0x4000.C000
 UART1 base: 0x4000.D000
 UART2 base: 0x4000.E000
 UART3 base: 0x4000.F000
 UART4 base: 0x4001.0000
 UART5 base: 0x4001.1000
 UART6 base: 0x4001.2000
 UART7 base: 0x4001.3000
 Offset 0xFD8
 Type RO, reset 0x0000.0000



Bit/Field	Name	Type	Reset	Description
31:8	reserved	RO	0x0000.00	Software should not rely on the value of a reserved bit. To provide compatibility with future products, the value of a reserved bit should be preserved across a read-modify-write operation.
7:0	PID6	RO	0x00	UART Peripheral ID Register [23:16] Can be used by software to identify the presence of this peripheral.

Register 22: UART Peripheral Identification 7 (UARTPeriphID7), offset 0xFDC

The **UARTPeriphIDn** registers are hard-coded and the fields within the registers determine the reset values.

UART Peripheral Identification 7 (UARTPeriphID7)

UART0 base: 0x4000.C000
 UART1 base: 0x4000.D000
 UART2 base: 0x4000.E000
 UART3 base: 0x4000.F000
 UART4 base: 0x4001.0000
 UART5 base: 0x4001.1000
 UART6 base: 0x4001.2000
 UART7 base: 0x4001.3000
 Offset 0xFDC
 Type RO, reset 0x0000.0000

	31	30	29	28	27	26	25	24	23	22	21	20	19	18	17	16
	reserved															
Type	RO	RO	RO	RO	RO	RO	RO	RO	RO	RO	RO	RO	RO	RO	RO	RO
Reset	0	0	0	0	0	0	0	0	0	0	0	0	0	0	0	0
	15	14	13	12	11	10	9	8	7	6	5	4	3	2	1	0
	reserved								PID7							
Type	RO	RO	RO	RO	RO	RO	RO	RO	RO	RO	RO	RO	RO	RO	RO	RO
Reset	0	0	0	0	0	0	0	0	0	0	0	0	0	0	0	0

Bit/Field	Name	Type	Reset	Description
31:8	reserved	RO	0x0000.00	Software should not rely on the value of a reserved bit. To provide compatibility with future products, the value of a reserved bit should be preserved across a read-modify-write operation.
7:0	PID7	RO	0x00	UART Peripheral ID Register [31:24] Can be used by software to identify the presence of this peripheral.

Register 23: UART Peripheral Identification 0 (UARTPeriphID0), offset 0xFE0

The **UARTPeriphIDn** registers are hard-coded and the fields within the registers determine the reset values.

UART Peripheral Identification 0 (UARTPeriphID0)

UART0 base: 0x4000.C000
 UART1 base: 0x4000.D000
 UART2 base: 0x4000.E000
 UART3 base: 0x4000.F000
 UART4 base: 0x4001.0000
 UART5 base: 0x4001.1000
 UART6 base: 0x4001.2000
 UART7 base: 0x4001.3000
 Offset 0xFE0
 Type RO, reset 0x0000.0011

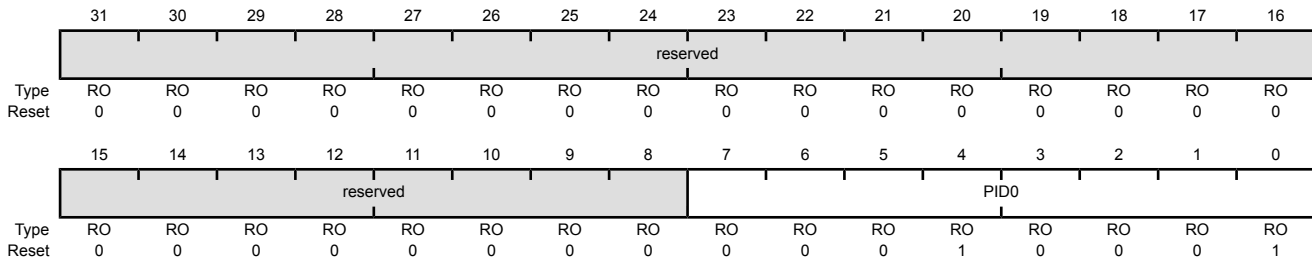

Bit/Field	Name	Type	Reset	Description
31:8	reserved	RO	0x0000.00	Software should not rely on the value of a reserved bit. To provide compatibility with future products, the value of a reserved bit should be preserved across a read-modify-write operation.
7:0	PID0	RO	0x11	UART Peripheral ID Register [7:0] Can be used by software to identify the presence of this peripheral.

Register 24: UART Peripheral Identification 1 (UARTPeriphID1), offset 0xFE4

The **UARTPeriphIDn** registers are hard-coded and the fields within the registers determine the reset values.

UART Peripheral Identification 1 (UARTPeriphID1)

UART0 base: 0x4000.C000
 UART1 base: 0x4000.D000
 UART2 base: 0x4000.E000
 UART3 base: 0x4000.F000
 UART4 base: 0x4001.0000
 UART5 base: 0x4001.1000
 UART6 base: 0x4001.2000
 UART7 base: 0x4001.3000
 Offset 0xFE4
 Type RO, reset 0x0000.0000

	31	30	29	28	27	26	25	24	23	22	21	20	19	18	17	16
	reserved															
Type	RO	RO	RO	RO	RO	RO	RO	RO	RO	RO	RO	RO	RO	RO	RO	RO
Reset	0	0	0	0	0	0	0	0	0	0	0	0	0	0	0	0
	15	14	13	12	11	10	9	8	7	6	5	4	3	2	1	0
	reserved								PID1							
Type	RO	RO	RO	RO	RO	RO	RO	RO	RO	RO	RO	RO	RO	RO	RO	RO
Reset	0	0	0	0	0	0	0	0	0	0	0	0	0	0	0	0

Bit/Field	Name	Type	Reset	Description
31:8	reserved	RO	0x0000.00	Software should not rely on the value of a reserved bit. To provide compatibility with future products, the value of a reserved bit should be preserved across a read-modify-write operation.
7:0	PID1	RO	0x00	UART Peripheral ID Register [15:8] Can be used by software to identify the presence of this peripheral.

Register 25: UART Peripheral Identification 2 (UARTPeriphID2), offset 0xFE8

The **UARTPeriphIDn** registers are hard-coded and the fields within the registers determine the reset values.

UART Peripheral Identification 2 (UARTPeriphID2)

UART0 base: 0x4000.C000
 UART1 base: 0x4000.D000
 UART2 base: 0x4000.E000
 UART3 base: 0x4000.F000
 UART4 base: 0x4001.0000
 UART5 base: 0x4001.1000
 UART6 base: 0x4001.2000
 UART7 base: 0x4001.3000
 Offset 0xFE8
 Type RO, reset 0x0000.0018

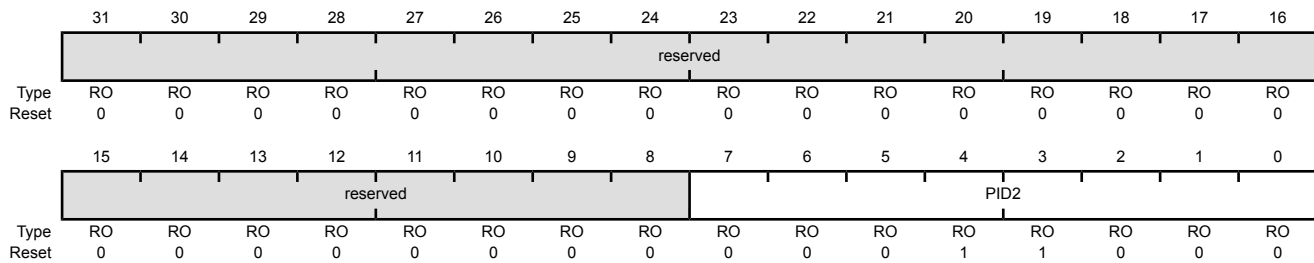

Bit/Field	Name	Type	Reset	Description
31:8	reserved	RO	0x0000.00	Software should not rely on the value of a reserved bit. To provide compatibility with future products, the value of a reserved bit should be preserved across a read-modify-write operation.
7:0	PID2	RO	0x18	UART Peripheral ID Register [23:16] Can be used by software to identify the presence of this peripheral.

Register 26: UART Peripheral Identification 3 (UARTPeriphID3), offset 0xFEC

The **UARTPeriphIDn** registers are hard-coded and the fields within the registers determine the reset values.

UART Peripheral Identification 3 (UARTPeriphID3)

UART0 base: 0x4000.C000
 UART1 base: 0x4000.D000
 UART2 base: 0x4000.E000
 UART3 base: 0x4000.F000
 UART4 base: 0x4001.0000
 UART5 base: 0x4001.1000
 UART6 base: 0x4001.2000
 UART7 base: 0x4001.3000
 Offset 0xFEC
 Type RO, reset 0x0000.0001

	31	30	29	28	27	26	25	24	23	22	21	20	19	18	17	16
	reserved															
Type	RO	RO	RO	RO	RO	RO	RO	RO	RO	RO	RO	RO	RO	RO	RO	RO
Reset	0	0	0	0	0	0	0	0	0	0	0	0	0	0	0	0
	15	14	13	12	11	10	9	8	7	6	5	4	3	2	1	0
	reserved								PID3							
Type	RO	RO	RO	RO	RO	RO	RO	RO	RO	RO	RO	RO	RO	RO	RO	RO
Reset	0	0	0	0	0	0	0	0	0	0	0	0	0	0	0	1

Bit/Field	Name	Type	Reset	Description
31:8	reserved	RO	0x0000.00	Software should not rely on the value of a reserved bit. To provide compatibility with future products, the value of a reserved bit should be preserved across a read-modify-write operation.
7:0	PID3	RO	0x01	UART Peripheral ID Register [31:24] Can be used by software to identify the presence of this peripheral.

Register 27: UART PrimeCell Identification 0 (UARTPCellID0), offset 0xFF0

The **UARTPCellIDn** registers are hard-coded and the fields within the registers determine the reset values.

UART PrimeCell Identification 0 (UARTPCellID0)

UART0 base: 0x4000.C000
 UART1 base: 0x4000.D000
 UART2 base: 0x4000.E000
 UART3 base: 0x4000.F000
 UART4 base: 0x4001.0000
 UART5 base: 0x4001.1000
 UART6 base: 0x4001.2000
 UART7 base: 0x4001.3000
 Offset 0xFF0
 Type RO, reset 0x0000.000D

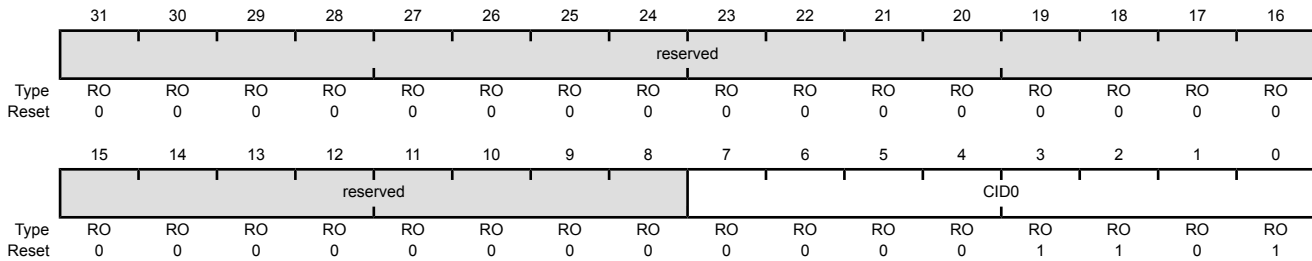

Bit/Field	Name	Type	Reset	Description
31:8	reserved	RO	0x0000.00	Software should not rely on the value of a reserved bit. To provide compatibility with future products, the value of a reserved bit should be preserved across a read-modify-write operation.
7:0	CID0	RO	0x0D	UART PrimeCell ID Register [7:0] Provides software a standard cross-peripheral identification system.

Register 28: UART PrimeCell Identification 1 (UARTPCelIID1), offset 0xFF4

The **UARTPCelIIDn** registers are hard-coded and the fields within the registers determine the reset values.

UART PrimeCell Identification 1 (UARTPCelIID1)

UART0 base: 0x4000.C000
 UART1 base: 0x4000.D000
 UART2 base: 0x4000.E000
 UART3 base: 0x4000.F000
 UART4 base: 0x4001.0000
 UART5 base: 0x4001.1000
 UART6 base: 0x4001.2000
 UART7 base: 0x4001.3000
 Offset 0xFF4
 Type RO, reset 0x0000.00F0

	31	30	29	28	27	26	25	24	23	22	21	20	19	18	17	16
	reserved															
Type	RO	RO	RO	RO	RO	RO	RO	RO	RO	RO	RO	RO	RO	RO	RO	RO
Reset	0	0	0	0	0	0	0	0	0	0	0	0	0	0	0	0
	15	14	13	12	11	10	9	8	7	6	5	4	3	2	1	0
	reserved								CID1							
Type	RO	RO	RO	RO	RO	RO	RO	RO	RO	RO	RO	RO	RO	RO	RO	RO
Reset	0	0	0	0	0	0	0	0	1	1	1	1	0	0	0	0

Bit/Field	Name	Type	Reset	Description
31:8	reserved	RO	0x0000.00	Software should not rely on the value of a reserved bit. To provide compatibility with future products, the value of a reserved bit should be preserved across a read-modify-write operation.
7:0	CID1	RO	0xF0	UART PrimeCell ID Register [15:8] Provides software a standard cross-peripheral identification system.

Register 29: UART PrimeCell Identification 2 (UARTPCellID2), offset 0xFF8

The **UARTPCellIDn** registers are hard-coded and the fields within the registers determine the reset values.

UART PrimeCell Identification 2 (UARTPCellID2)

UART0 base: 0x4000.C000
 UART1 base: 0x4000.D000
 UART2 base: 0x4000.E000
 UART3 base: 0x4000.F000
 UART4 base: 0x4001.0000
 UART5 base: 0x4001.1000
 UART6 base: 0x4001.2000
 UART7 base: 0x4001.3000
 Offset 0xFF8
 Type RO, reset 0x0000.0005

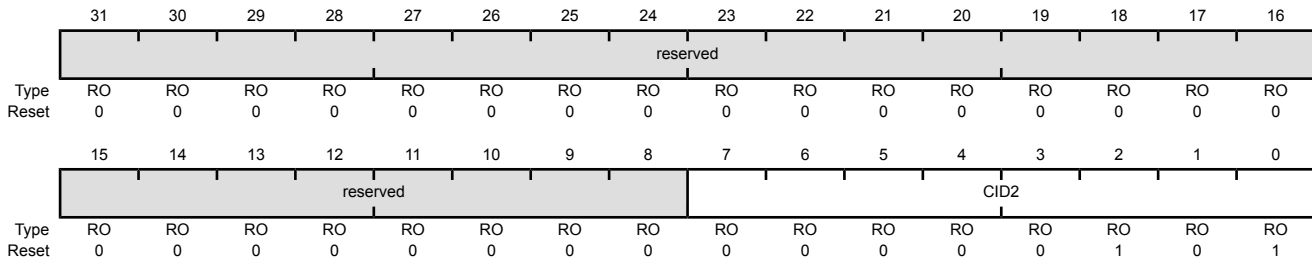

Bit/Field	Name	Type	Reset	Description
31:8	reserved	RO	0x0000.00	Software should not rely on the value of a reserved bit. To provide compatibility with future products, the value of a reserved bit should be preserved across a read-modify-write operation.
7:0	CID2	RO	0x05	UART PrimeCell ID Register [23:16] Provides software a standard cross-peripheral identification system.

Register 30: UART PrimeCell Identification 3 (UARTPCelIID3), offset 0xFFC

The **UARTPCelIIDn** registers are hard-coded and the fields within the registers determine the reset values.

UART PrimeCell Identification 3 (UARTPCelIID3)

UART0 base: 0x4000.C000
 UART1 base: 0x4000.D000
 UART2 base: 0x4000.E000
 UART3 base: 0x4000.F000
 UART4 base: 0x4001.0000
 UART5 base: 0x4001.1000
 UART6 base: 0x4001.2000
 UART7 base: 0x4001.3000
 Offset 0xFFC
 Type RO, reset 0x0000.00B1

	31	30	29	28	27	26	25	24	23	22	21	20	19	18	17	16
	reserved															
Type	RO	RO	RO	RO	RO	RO	RO	RO	RO	RO	RO	RO	RO	RO	RO	RO
Reset	0	0	0	0	0	0	0	0	0	0	0	0	0	0	0	0
	15	14	13	12	11	10	9	8	7	6	5	4	3	2	1	0
	reserved								CID3							
Type	RO	RO	RO	RO	RO	RO	RO	RO	RO	RO	RO	RO	RO	RO	RO	RO
Reset	0	0	0	0	0	0	0	0	1	0	1	1	0	0	0	1

Bit/Field	Name	Type	Reset	Description
31:8	reserved	RO	0x0000.00	Software should not rely on the value of a reserved bit. To provide compatibility with future products, the value of a reserved bit should be preserved across a read-modify-write operation.
7:0	CID3	RO	0xB1	UART PrimeCell ID Register [31:24] Provides software a standard cross-peripheral identification system.

20 Quad Synchronous Serial Interface (QSSI)

The TM4C129ENCPDT microcontroller includes four Quad-Synchronous Serial Interface (QSSI) modules. All four of the modules support Advanced and Bi-SSI interfaces as well as a Quad-SSI enhancement to provide faster throughput of data. The QSSI module acts as a master or slave interface for synchronous serial communication with peripheral devices that have either Freescale SPI, or Texas Instruments synchronous serial interfaces. The QSSI performs serial-to-parallel conversion on data received from a peripheral device. The transmit and receive paths are buffered with internal, independent FIFO memories allowing up to eight 16-bit values in Legacy mode and 8-bit values in Advanced, Bi-, and Quad-modes. The CPU can access data in these FIFOs as well as the QSSI's control and status information. A μ DMA interface is also provided to allow the transmit and receive FIFOs to be programmed as source/destination addresses in the μ DMA module.

The TM4C129ENCPDT QSSI modules have the following features:

- Four QSSI channels with Advanced, Bi- and Quad-SSI functionality
- Programmable interface operation for Freescale SPI or Texas Instruments synchronous serial interfaces in Legacy Mode. Support for Freescale interface in Bi- and Quad-SSI mode.
- Master or slave operation
- Programmable clock bit rate and prescaler
- Separate transmit and receive FIFOs, each 16 bits wide and 8 locations deep
- Programmable data frame size from 4 to 16 bits
- Internal loopback test mode for diagnostic/debug testing
- Standard FIFO-based interrupts and End-of-Transmission interrupt
- Efficient transfers using Micro Direct Memory Access Controller (μ DMA)
 - Separate channels for transmit and receive
 - Receive single request asserted when data is in the FIFO; burst request asserted when FIFO contains 4 entries
 - Transmit single request asserted when there is space in the FIFO; burst request asserted when four or more entries are available to be written in the FIFO
 - Maskable μ DMA interrupts for receive and transmit complete
- Global Alternate Clock (ALTCLK) resource or System Clock (SYSCLK) can be used to generate baud clock.

20.1 Block Diagram

The following figure below shows a block diagram of an QSSI module with Advanced, Bi- and Quad-SSI.

Figure 20-1. QSSI Module with Advanced, Bi-SSI and Quad-SSI Support

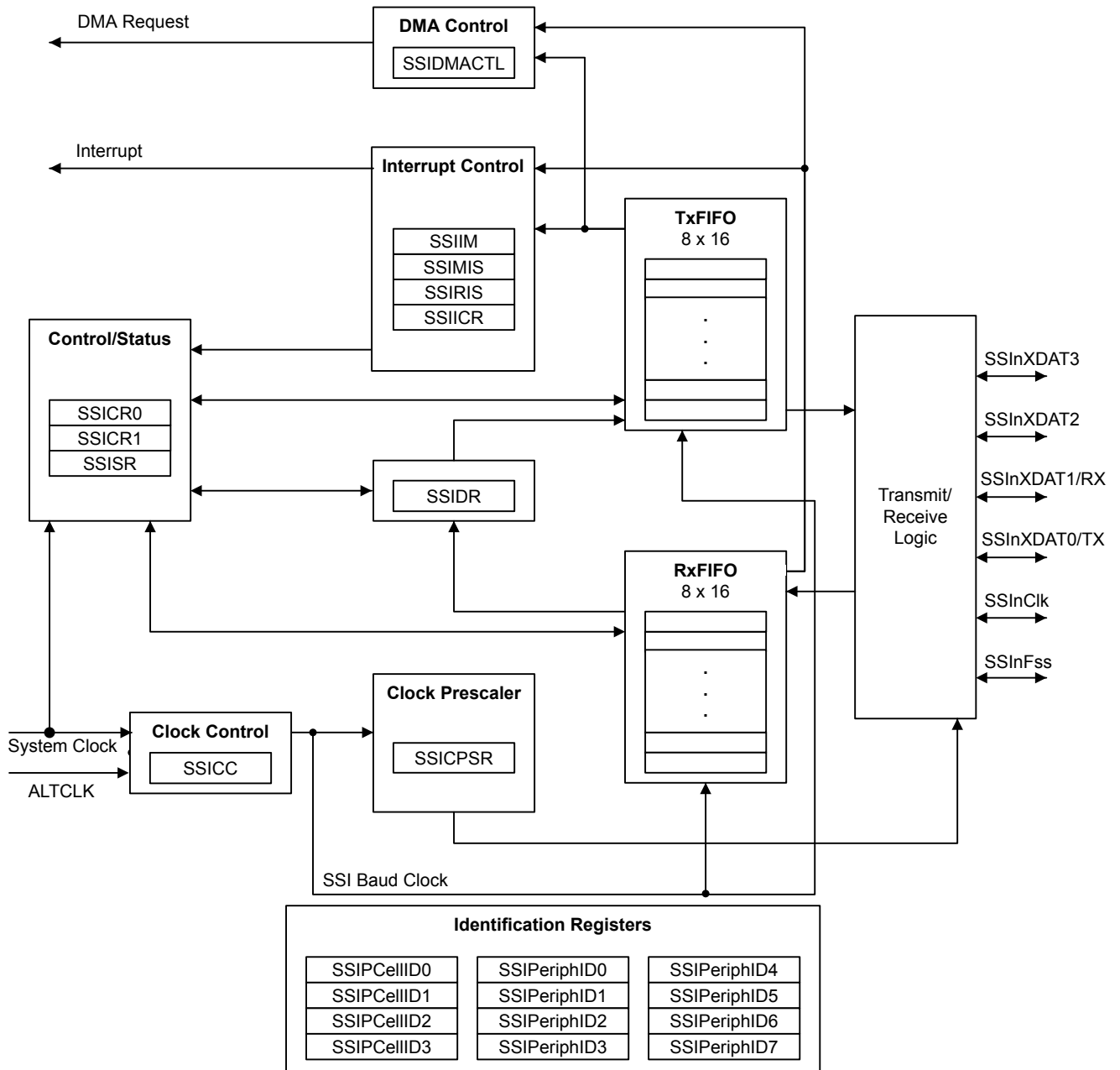

20.2 Signal Description

The following table lists the external signals of the QSSI module and describes the function of each. The QSSI signals are alternate functions for some GPIO signals and default to be GPIO signals at reset. The "Pin Mux/Pin Assignment" column in the following table lists the possible GPIO pin placements for the QSSI signals. The **AFSEL** bit in the **GPIO Alternate Function Select (GPIOAFSEL)** register (page 778) should be set to choose the QSSI function. The number in

parentheses is the encoding that must be programmed into the PMC_n field in the **GPIO Port Control (GPIOPCTL)** register (page 795) to assign the QSSI signal to the specified GPIO port pin. For more information on configuring GPIOs, see “General-Purpose Input/Outputs (GPIOs)” on page 750. Note that for the QSSI module, when operating in Legacy Mode, SSI_nXDAT0 functions as SSI_nTX and SSI_nXDAT1 functions as SSI_nRX .

Table 20-1. SSI Signals (128TQFP)

Pin Name	Pin Number	Pin Mux / Pin Assignment	Pin Type	Buffer Type	Description
SSI0Clk	35	PA2 (15)	I/O	TTL	SSI module 0 clock
SSI0Fss	36	PA3 (15)	I/O	TTL	SSI module 0 frame signal
SSI0XDAT0	37	PA4 (15)	I/O	TTL	SSI Module 0 Bi-directional Data Pin 0 ($SSI0TX$ in Legacy SSI Mode).
SSI0XDAT1	38	PA5 (15)	I/O	TTL	SSI Module 0 Bi-directional Data Pin 1 ($SSI0RX$ in Legacy SSI Mode).
SSI0XDAT2	40	PA6 (13)	I/O	TTL	SSI Module 0 Bi-directional Data Pin 2.
SSI0XDAT3	41	PA7 (13)	I/O	TTL	SSI Module 0 Bi-directional Data Pin 3.
SSI1Clk	120	PB5 (15)	I/O	TTL	SSI module 1 clock.
SSI1Fss	121	PB4 (15)	I/O	TTL	SSI module 1 frame signal.
SSI1XDAT0	123	PE4 (15)	I/O	TTL	SSI Module 1 Bi-directional Data Pin 0 ($SSI1TX$ in Legacy SSI Mode).
SSI1XDAT1	124	PE5 (15)	I/O	TTL	SSI Module 1 Bi-directional Data Pin 1 ($SSI1RX$ in Legacy SSI Mode).
SSI1XDAT2	125	PD4 (15)	I/O	TTL	SSI Module 1 Bi-directional Data Pin 2.
SSI1XDAT3	126	PD5 (15)	I/O	TTL	SSI Module 1 Bi-directional Data Pin 3.
SSI2Clk	4	PD3 (15)	I/O	TTL	SSI module 2 clock.
SSI2Fss	3	PD2 (15)	I/O	TTL	SSI module 2 frame signal.
SSI2XDAT0	2	PD1 (15)	I/O	TTL	SSI Module 2 Bi-directional Data Pin 0 ($SSI2TX$ in Legacy SSI Mode).
SSI2XDAT1	1	PD0 (15)	I/O	TTL	SSI Module 2 Bi-directional Data Pin 1 ($SSI2RX$ in Legacy SSI Mode).
SSI2XDAT2	128	PD7 (15)	I/O	TTL	SSI Module 2 Bi-directional Data Pin 2.
SSI2XDAT3	127	PD6 (15)	I/O	TTL	SSI Module 2 Bi-directional Data Pin 3.
SSI3Clk	5 45	PQ0 (14) PF3 (14)	I/O	TTL	SSI module 3 clock.
SSI3Fss	6 44	PQ1 (14) PF2 (14)	I/O	TTL	SSI module 3 frame signal.
SSI3XDAT0	11 43	PQ2 (14) PF1 (14)	I/O	TTL	SSI Module 3 Bi-directional Data Pin 0 ($SSI3TX$ in Legacy SSI Mode).
SSI3XDAT1	27 42	PQ3 (14) PF0 (14)	I/O	TTL	SSI Module 3 Bi-directional Data Pin 1 ($SSI3RX$ in Legacy SSI Mode).
SSI3XDAT2	46 118	PF4 (14) PP0 (15)	I/O	TTL	SSI Module 3 Bi-directional Data Pin 2.
SSI3XDAT3	119	PP1 (15)	I/O	TTL	SSI Module 3 Bi-directional Data Pin 3.

20.3 Functional Description

The QSSI performs serial-to-parallel conversion on data received from a peripheral device. The CPU accesses data, control, and status information. The transmit and receive paths are buffered

with internal FIFO memories allowing up to eight 16-bit values to be stored independently in both transmit and receive modes. The QSSI also supports the μ DMA interface. The transmit and receive FIFOs can be programmed as destination/source addresses in the μ DMA module. μ DMA operation is enabled by setting the appropriate bit(s) in the **SSIDMACTL** register (see page 1384).

20.3.1 Bit Rate Generation

The QSSI includes a programmable bit rate clock divider and prescaler to generate the serial output clock. Bit rates are supported to 2 MHz and higher, although maximum bit rate is determined by peripheral devices.

The serial bit rate is derived by dividing down the input clock (SysClk). The clock is first divided by an even prescale value **CPSDVSR** from 2 to 254, which is programmed in the **SSI Clock Prescale (SSICPSR)** register (see page 1376). The clock is further divided by a value from 1 to 256, which is $1 + \text{SCR}$, where **SCR** is the value programmed in the **SSI Control 0 (SSICR0)** register (see page 1369).

The frequency of the output clock **SSInClk** is defined by:

$$\text{SSInClk} = \text{SysClk} / (\text{CPSDVSR} * (1 + \text{SCR}))$$

Note: **SYSClk** or **ALTCLK** is used as the source for the **SSInClk** depending on how the **CS** field in the **SSI Clock Configuration (SSICC)** register is configured. For master legacy mode, the **SYSClk** or **ALTCLK** must be at least two times faster than the **SSInClk**, with the restriction that **SSInClk** cannot be faster than 60 MHz. For slave mode, **SYSClk** or **ALTCLK** must be at least 12 times faster than the **SSInClk**. In slave legacy mode, the maximum frequency of **SSInClk** is 10 MHz.

See “Synchronous Serial Interface (SSI)” on page 1991 to view legacy SSI and QSSI timing parameters.

20.3.2 FIFO Operation

20.3.2.1 Transmit FIFO

The common transmit FIFO is a 16-bit wide, 8-locations deep, first-in, first-out memory buffer. The CPU writes data to the FIFO by writing the **SSI Data (SSIDR)** register (see page 1373), and data is stored in the FIFO until it is read out by the transmission logic.

When configured as a master or a slave, parallel data is written into the transmit FIFO prior to a legacy SSI serial conversion and transmission to the attached slave or master, respectively, through the **SSInDAT0/SSInTX** pin.

In slave mode, the legacy SSI transmits data each time the master initiates a transaction. If the transmit FIFO is empty and the master initiates, the slave transmits the 8th most recent value in the transmit FIFO. If less than 8 values have been written to the transmit FIFO since the SSI module clock was enabled using the **Rn** bit in the **RCGCSSI** register or if the QSSI is reset using the **SRSSI** register, then 0 is transmitted. Care should be taken to ensure that valid data is in the FIFO as needed. The QSSI can be configured to generate an interrupt or a μ DMA request when the FIFO is empty.

Note: When operating in Legacy Mode, the QuadSSI's **SSInXDAT0** signal functions as **SSInTX**.

20.3.2.2 Receive FIFO

The common receive FIFO is a 16-bit wide, 8-locations deep, first-in, first-out memory buffer. Received data using the legacy serial interface is stored in the buffer until read out by the CPU, which accesses the read FIFO by reading the **SSIDR** register. If the receive FIFO is full when the master or slave receives new data, the data is held off until the receive FIFO has space.

The SSI only provides an SSIClk while transmitting data. When receiving data in master mode, a dummy write to the **SSIDR** register must be performed before any read so that the SSIClk can be properly received by the slave and allow data to be sent to the receive FIFO of the master.

When configured as a master or slave, serial data received through the SSInDAT1/SSInRX pin is registered prior to parallel loading into the attached slave or master receive FIFO, respectively.

Note: When operating in Legacy Mode, the QSSI's SSInXDAT1 signal functions as SSInRX.

20.3.3 Advanced, Bi- and Quad- SSI Function

Bi-SSI uses two data pins, SSInXDAT0 and SSInXDAT1, that can be configured to receive or transmit data. In Quad-SSI mode, SSInXDAT0, SSInXDAT1, SSInXDAT2 and SSInXDAT3 allow four bits of data to be received or transmitted at once. Note that in bi- and quad-SSI data transfers are only half-duplex.

By programming the **MODE** bits in the **SSICR1** register, Advanced, Bi- or Quad- SSI can be enabled. A direction bit, **DIR**, is provided to program the direction of operation during a Bi- or Quad SSI-transaction. Since Bi- and Quad-SSI cannot be full duplex, the **DIR** bit defines whether or not the RX FIFO is disabled. In Advanced operation, if the QSSI module TX (write) mode is enabled, the RX FIFO is automatically prevented from receiving any data. When Advanced SSI is in RX (read) mode, it operates as a full-duplex interface.

In Bi- and Quad-SSI mode, because only 8-bit data is allowed, the **DSS** bit field must be programmed to 0x7 in the **SSICR0** register before transferring data to the Rx and TX FIFOs. For a data transmit, the 8-bit data packet is placed in a TX FIFO entry bits [7:0] and the mode of operation is inserted in the three most significant bits of the TX FIFO entry. The mode of operation bits [15:13] in the TX FIFO are used by the QSSI module for configuring the data on the proper pins. The following modes that may be placed on bits [15:13] of the FIFO entry are:

- Bi-SSI mode (0x1)
- Quad-SSI mode (0x2)
- Advanced SSI mode (0x3)

When data is first written to the TX FIFO, a SSInFSS is asserted low indicating the start of a frame. At the end of transmission, bit 12 of the last data entry in the TX FIFO signifies whether a frame is ending. When the **EOM** bit is 1 it indicates a End of Message (EOM or STOP frame) and SSInFSS is subsequently forced high. The **EOM** bit is cleared in the **SSICR1** register on the same clock that the write to TXFIFO is completed. An **EOM** bit value of 0 indicates no change in transmission. If TX FIFO is emptied and SSInFSS is still asserted low, it remains low but SSInCLK is not pulsed. Likewise, if SSInFSS is high when the TX FIFO is empty, it remains high.

During a Bi-SSI transmit frame, data is shifted out by two bits and placed on the corresponding two SSInDATn pins. For a Quad-SSI transmit frame data is shifted out by four bits and placed on the corresponding four SSInDATn pins.

In Bi-, Quad- and Advanced SSI, the lower byte of the Rx FIFO contains received data. The upper byte contains no valid information.

Note: While the master is in Bi- or Quad-SSI mode, if the **DSS** bit in the **SSICR0** register is not set to 0x7, the QSSI module reverts to Legacy mode and behavior is not guaranteed.

The **SSICR1** register bits **DIR** and **MODE** are used to program what operation is needed for the next data bytes that are being loaded into the FIFO. Table 20-2 on page 1355 shows available modes of operation:

Table 20-2. QSSI Transaction Encodings

DIR	MODE	Operation
X	0x0	SSI Legacy operation supporting 4 to 16 data bits
0	0x1	Transmit (TX) Bi-SSI with 8-bits of packet data
0	0x2	Transmit (TX) Quad-SSI with 8-bits of packet data
0	0x3	Transmit (TX) Advanced SSI mode with 8-bits of packet data and write RX FIFO disabled
1	0x1	Receive (RX) Bi-SSI with 8-bits of packet data
1	0x2	Receive (RX) Quad-SSI with 8-bits of packet data
1	0x3	Full duplex Advance SSI with 8-bits of packet data

Note: $SPO = 0$ and $SPH = 0$ is the only frame structure allowed for Advanced, Bi- and Quad-mode.

Different transactions can follow one another in the FIFOs. The following transaction combinations are allowed:

- Legacy SSI mode (if configured for this mode, switching to any other alternate mode is not recommended)
- Advanced SSI mode followed by Bi-SSI mode
- Advanced SSI mode followed by Quad-SSI mode
- Advanced SSI mode followed by Bi-SSI mode followed by Advanced SSI mode
- Advanced SSI mode followed by Quad-SSI mode followed by Advanced SSI mode

Note that switching between Quad-SSI and Bi-SSI is not encouraged in a single transaction.

20.3.4 SSInFSS Function

For enhanced modes of operation, the $SSInFss$ signal can be programmed to assert low at the start of each byte transfer for one clock or the entire frame. This is configured by programming the $FSSHLDfrm$ bit in the **SSICR1** register. The EOM bit is also provided to signify end of frame transmission. This bit is embedded in the TXFIFO entry for use at the interface to deassert $SSInFss$ at the appropriate time. The $FSSHLDfrm$ bit can also be used when operating in 8-bit Legacy SSI mode.

The functionality of the $FSSHLDfrm$ bit for both Legacy SSI mode and the enhanced modes are as follows:

Table 20-3. SSInFss Functionality

Mode	FSSHLDfrm	Description
Legacy Mode	0	For Freescale format, with $SPH = 0$, the $SSInFss$ signal is asserted low between continuous transfers. For $SPH = 1$, the $SSInFss$ signal is deasserted (high) between continuous transfers. For TI format, the $SSInFss$ signal is deasserted (high) after every data transfer.
	1	For Freescale format with any SPH value, the $SSInFss$ signal is forced high between continuous transfers; it is asserted low when there is available data in the Tx FIFO; otherwise it is forced high to be ready for a new frame

Table 20-3. SSInFss Functionality (continued)

Mode	FSSHLDFRM	Description
Advanced/Bi-/Quad-SSI Mode	0	SSInFss is asserted low after every byte of data
	1	New data written to the TX FIFO notifies SSInFss to assert low until the Tx FIFO is empty.

20.3.5 High Speed Clock Operation

In master mode, QSSI module can enable a high speed clock by setting the `HSCLKEN` bit in the **SSI Control 1 (SSICR1)** register. In this mode of operation, `SSInCLK` from the QSSI master operation is reflected back as a loopback clock, `HSPEEDCLK`, to the QSSI module. This allows faster timing since the logic can be used to adjust clock to external data relationships. `HSPEEDCLK` captures RX data in a separate register. This allows the time between the clock as seen by a remote device and the internal clock to match more closely.

Receive data is captured in a separate register sampled on loop-back clock (`HSPEEDCLK`) and the RX FIFO write control registered on `HSPEEDCLK`. If the `HSCKEN` = 1, the corresponding shift register and FIFO write enable will be selected for use. This supports faster QSSI master speed.

Note: For proper functionality of high speed mode, the `HSCLKEN` bit in the **SSICR1** register should be set before any SSI data transfer or after applying a reset to the QSSI module. In addition, the `SSE` bit must be set to 0x1 before the `HSCLKEN` bit is set.

20.3.6 Interrupts

The QSSI can generate interrupts when the following conditions are observed:

- Transmit FIFO service (when the transmit FIFO is half full or less)
- Receive FIFO service (when the receive FIFO is half full or more)
- Receive FIFO time-out
- Receive FIFO overrun
- End of transmission
- Receive DMA transfer complete
- Transmit DMA transfer complete

All of the interrupt events are ORed together before being sent to the interrupt controller, so the QSSI generates a single interrupt request to the controller regardless of the number of active interrupts. Each of the seven individual maskable interrupts can be masked by clearing the appropriate bit in the **SSI Interrupt Mask (SSIIM)** register (see page 1377). Setting the appropriate mask bit enables the interrupt.

The individual outputs, along with a combined interrupt output, allow use of either a global interrupt service routine or modular device drivers to handle interrupts. The transmit and receive dynamic dataflow interrupts have been separated from the status interrupts so that data can be read or written in response to the FIFO trigger levels. The status of the individual interrupt sources can be read from the **SSI Raw Interrupt Status (SSIRIS)** and **SSI Masked Interrupt Status (SSIMIS)** registers (see page 1379 and page 1381, respectively).

The RX FIFO has an associated time-out counter which starts to down count at the same time the RX FIFO is flagged as not empty by the `RNE` bit in the **SSISR** register. The counter is reset any time

a new or next byte is written to the RX FIFO, thus the counter will continue to count down to zero unless there is new activity. The time-out period is 32 periods based on the period of `SSInClk`. When the counter reaches zero, a time-out interrupt bit, `RTRIS`, is set in the **SSIRIS** register. The time-out interrupt can be cleared by writing a 1 to the `RTIC` bit of the **SSI Interrupt Clear (SSIC)** register or by emptying the RX FIFO. If the interrupt is cleared and there is residual data left in the RX FIFO or new data entries have been written, the timer count down initiates and the interrupt will be reasserted after 32 periods have been counted.

The End-of-Transmission (EOT) interrupt indicates that the data has been transmitted completely and is only valid for Master mode devices/operations. This interrupt can be used to indicate when it is safe to turn off the QSSI module clock or enter sleep mode. In addition, because transmitted data and received data complete at exactly the same time, the interrupt can also indicate that read data is ready immediately, without waiting for the receive FIFO time-out period to complete.

Note: In Freescale SPI mode only, a condition can be created where an EOT interrupt is generated for every byte transferred even if the FIFO is full. If the the μ DMA has been configured to transfer data from this QSSI to a Master QSSI on the device using external loopback, an EOT interrupt is generated by the QSSI slave for every byte even if the FIFO is full.

20.3.7 Frame Formats

Each data frame is between 4 and 16 bits long in Legacy mode and 8-bits in Advanced/Bi-/Quad-SSI mode and is transmitted starting with the MSB. There are two basic frame types that can be selected by programming the `FRF` bit in the **SSICR0** register:

- Texas Instruments synchronous serial
- Freescale SPI

Note: Advanced, Bi- and Quad-SSI modules only supports Freescale mode when `SPH=0`; `SPO=0` and `DDS=0x8` in the **SSI Control 0 (SSICR0)** register.

For both formats, the serial clock (`SSInClk`) is held inactive while the QSSI is idle, and `SSInClk` transitions at the programmed frequency only during active transmission or reception of data. The idle state of `SSInClk` is utilized to provide a receive timeout indication that occurs when the receive FIFO still contains data after a timeout period.

For Freescale SPI frame format, the serial frame (`SSInFss`) pin is active Low, and is asserted (pulled down) during the entire transmission of the frame.

For Texas Instruments synchronous serial frame format, the `SSInFss` pin is pulsed for one serial clock period starting at its rising edge, prior to the transmission of each frame. For this frame format, both the QSSI and the off-chip slave device drive their output data on the rising edge of `SSInClk` and latch data from the other device on the falling edge.

The following table gives a synopsis of the features supported in each frame format when operating in Legacy Mode:

Table 20-4. Legacy Mode TI, Freescale SPI Frame Format Features

Feature	TI Mode	Freescale SPI Mode
Frame Hold	Not Available	Available
High Speed (Master RX Only)	Not Available	Available
SPO/SPH Configuration	Not Available	Available and can be used in combination with Frame Hold and High Speed Mode

Table 20-4. Legacy Mode TI, Freescale SPI Frame Format Features (continued)

Feature	TI Mode	Freescale SPI Mode
Frequency (system clock : SSInCLK)	Master 1:2 Slave 1:12	Master 1:2 Slave 1:12

For Advanced, Bi- and Quad-SSI modes using the Freescale SPI Format or the Bi- and Quad-SSI modes using the TI format, the following features are supported:

- Frame Hold
- High Speed (Master RX Only)
- SPO/SPH Configuration with SPO=0 and SPH=0 only allowed
- Frequency (system clock : SSInCLK):
 - Master 1:2
 - Slave 1:12

20.3.7.1 Texas Instruments Synchronous Serial Frame Format

Figure 20-2 on page 1358 shows the Texas Instruments synchronous serial frame format for a single transmitted frame.

Figure 20-2. TI Synchronous Serial Frame Format (Single Transfer)

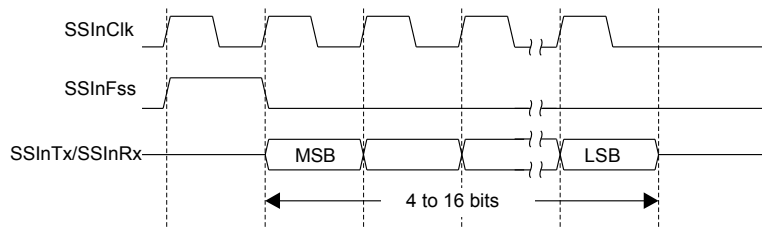

In this mode, SSInClk and SSInFss are forced Low, and the transmit data line SSInDAT0/SSInTX is tristated whenever the QSSI is idle. Once the bottom entry of the transmit FIFO contains data, SSInFss is pulsed High for one SSInClk period. The value to be transmitted is also transferred from the transmit FIFO to the serial shift register of the transmit logic. On the next rising edge of SSInClk, the MSB of the 4 to 16-bit data frame is shifted out on the SSInDAT0/SSInTX pin. Likewise, the MSB of the received data is shifted onto the SSInDAT1/SSInRX pin by the off-chip serial slave device.

Both the QSSI and the off-chip serial slave device then clock each data bit into their serial shifter on each falling edge of SSInClk. The received data is transferred from the serial shifter to the receive FIFO on the first rising edge of SSInClk after the LSB has been latched.

Figure 20-3 on page 1359 shows the Texas Instruments synchronous serial frame format when back-to-back frames are transmitted.

Figure 20-3. TI Synchronous Serial Frame Format (Continuous Transfer)

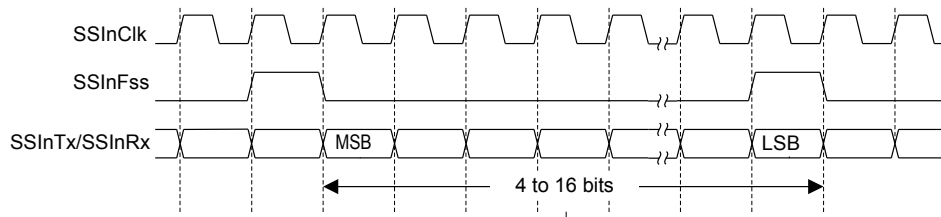

20.3.7.2 Freescale SPI Frame Format

The Freescale SPI interface is a four-wire interface where the **SSInFss** signal behaves as a slave select. If operating in Legacy Mode and using the Freescale SPI Frame Format, the inactive state and phase of the **SSInClk** signal are programmable through the **SPO** and **SPH** bits in the **SSICR0** control register. If operating in Advanced/Bi-/Quad-SSI mode, the **SPO** and **SPH** bits must be programmed to 0.

SPO Clock Polarity Bit

When the **SPO** clock polarity control bit is clear, it produces a steady state Low value on the **SSInClk** pin. If the **SPO** bit is set, a steady state High value is placed on the **SSInClk** pin when data is not being transferred.

SPH Phase Control Bit

The **SPH** phase control bit selects the clock edge that captures data and allows it to change state. The state of this bit has the most impact on the first bit transmitted by either allowing or not allowing a clock transition before the first data capture edge. When the **SPH** phase control bit is clear, data is captured on the first clock edge transition. If the **SPH** bit is set, data is captured on the second clock edge transition.

20.3.7.3 Freescale SPI Frame Format with SPO=0 and SPH=0

Single and continuous transmission signal sequences for Freescale SPI format with **SPO=0** and **SPH=0** are shown in Figure 20-4 on page 1360 and Figure 20-5 on page 1360.

Note: This is the only Freescale SPI frame format configuration that can be used when operating in Advanced/Bi-/Quad-SSI mode.

Figure 20-4. Freescale SPI Format (Single Transfer) with SPO=0 and SPH=0

Note: Q is undefined.

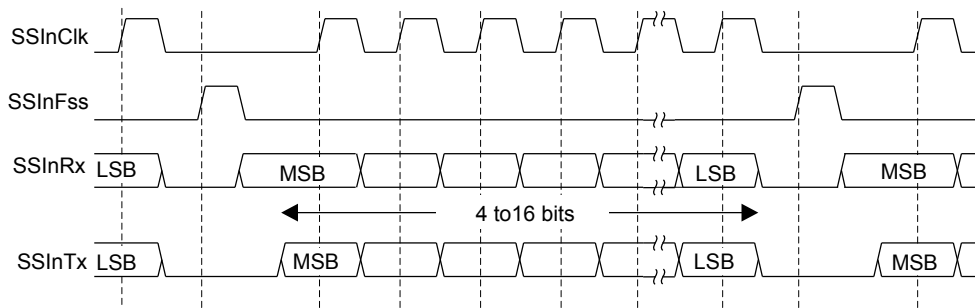
Figure 20-5. Freescale SPI Format (Continuous Transfer) with SPO=0 and SPH=0

In this configuration, during idle periods:

- SSInClk is forced Low
- SSInFss is forced High
- The transmit data line SSInDAT0/SSInTX is tristated
- When the QSSI is configured as a master, it enables the SSInClk pad
- When the QSSI is configured as a slave, it disables the SSInClk pad

If the QSSI is enabled and valid data is in the transmit FIFO, the start of transmission is signified by the SSInFss master signal being driven Low, causing slave data to be enabled onto the SSInDAT1/SSInRX input line of the master. The master SSInDAT0/SSInTX output pad is enabled.

One half SSInClk period later, valid master data is transferred to the SSInDAT0/SSInTX pin. Once both the master and slave data have been set, the SSInClk master clock pin goes High after one additional half SSInClk period.

The data is now captured on the rising and propagated on the falling edges of the SSInClk signal.

In the case of a single word transmission, after all bits of the data word have been transferred, the `SSInFss` line is returned to its idle High state one `SSInClk` period after the last bit has been captured.

However, in the case of continuous back-to-back transmissions, the `SSInFss` signal must be pulsed High between each data word transfer because the slave select pin freezes the data in its serial peripheral register and does not allow it to be altered if the `SPH` bit is clear. Therefore, the master device must raise the `SSInFss` pin of the slave device between each data transfer to enable the serial peripheral data write. On completion of the continuous transfer, the `SSInFss` pin is returned to its idle state one `SSInClk` period after the last bit has been captured.

20.3.7.4 Freescale SPI Frame Format with `SPO=0` and `SPH=1`

The transfer signal sequence for Freescale SPI format with `SPO=0` and `SPH=1` is shown in Figure 20-6 on page 1361, which covers both single and continuous transfers.

Note: This Freescale SPI frame format configuration is only available when operating in Legacy SSI mode of operation.

Figure 20-6. Freescale SPI Frame Format with `SPO=0` and `SPH=1`

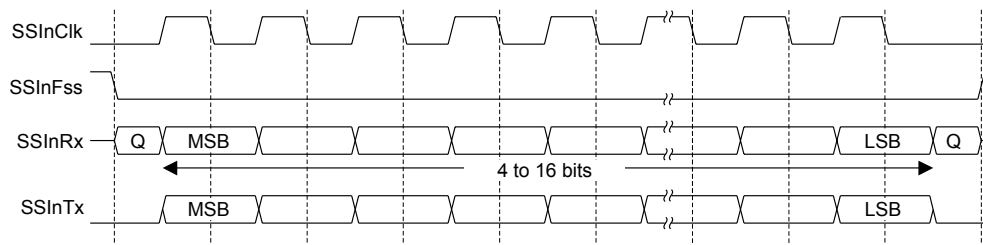

Note: Q is undefined.

In this configuration, during idle periods:

- `SSInClk` is forced Low
- `SSInFss` is forced High
- The transmit data line `SSInDAT0/SSInTX` is tristated
- When the QSSI is configured as a master, it enables the `SSInClk` pad
- When the QSSI is configured as a slave, it disables the `SSInClk` pad

If the QSSI is enabled and valid data is in the transmit FIFO, the start of transmission is signified by the `SSInFss` master signal being driven Low. The master `SSInDAT0/SSInTX` output is enabled. After an additional one-half `SSInClk` period, both master and slave valid data are enabled onto their respective transmission lines. At the same time, the `SSInClk` is enabled with a rising edge transition.

Data is then captured on the falling edges and propagated on the rising edges of the `SSInClk` signal.

In the case of a single word transfer, after all bits have been transferred, the $SSInFss$ line is returned to its idle High state one $SSInClk$ period after the last bit has been captured.

For continuous back-to-back transfers, the $SSInFss$ pin is held Low between successive data words, and termination is the same as that of the single word transfer.

20.3.7.5 Freescale SPI Frame Format with $SPO=1$ and $SPH=0$

Single and continuous transmission signal sequences for Freescale SPI format with $SPO=1$ and $SPH=0$ are shown in Figure 20-7 on page 1362 and Figure 20-8 on page 1362.

Note: This Freescale SPI frame format configuration is only available when operating in Legacy SSI mode of operation.

Figure 20-7. Freescale SPI Frame Format (Single Transfer) with $SPO=1$ and $SPH=0$

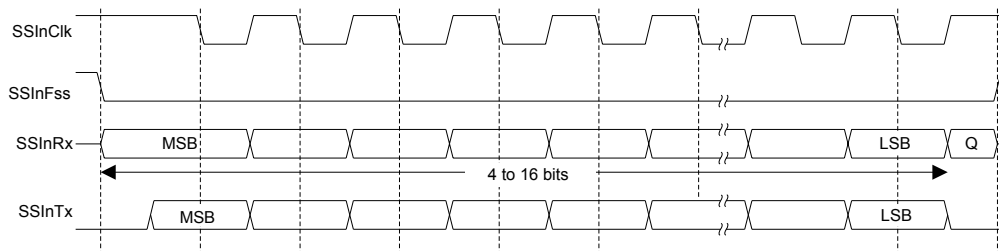

Note: Q is undefined.

Figure 20-8. Freescale SPI Frame Format (Continuous Transfer) with $SPO=1$ and $SPH=0$

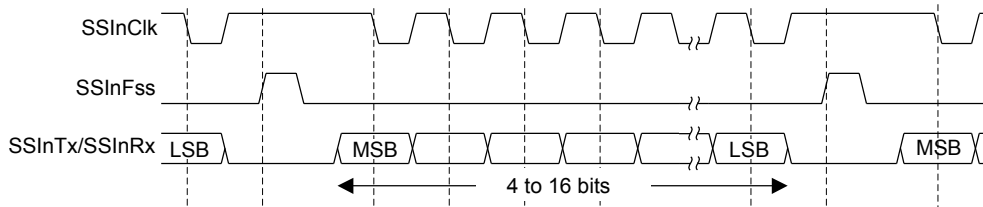

In this configuration, during idle periods:

- $SSInClk$ is forced High
- $SSInFss$ is forced High
- The transmit data line $SSInDAT0/SSInTX$ is tristated
- When the QSSI is configured as a master, it enables the $SSInClk$ pad
- When the QSSI is configured as a slave, it disables the $SSInClk$ pad

If the QSSI is enabled and valid data is in the transmit FIFO, the start of transmission is signified by the `SSInFss` master signal being driven Low, causing slave data to be immediately transferred onto the `SSInDAT1/SSInRX` line of the master. The master `SSInDAT0/SSInTX` output pad is enabled.

One-half period later, valid master data is transferred to the `SSInDAT0/SSInTX` line. Once both the master and slave data have been set, the `SSInClk` master clock pin becomes Low after one additional half `SSInClk` period, meaning that data is captured on the falling edges and propagated on the rising edges of the `SSInClk` signal.

In the case of a single word transmission, after all bits of the data word are transferred, the `SSInFss` line is returned to its idle High state one `SSInClk` period after the last bit has been captured.

However, in the case of continuous back-to-back transmissions, the `SSInFss` signal must be pulsed High between each data word transfer because the slave select pin freezes the data in its serial peripheral register and does not allow it to be altered if the `SPH` bit is clear. Therefore, the master device must raise the `SSInFss` pin of the slave device between each data transfer to enable the serial peripheral data write. On completion of the continuous transfer, the `SSInFss` pin is returned to its idle state one `SSInClk` period after the last bit has been captured.

20.3.7.6 Freescale SPI Frame Format with `SPO=1` and `SPH=1`

The transfer signal sequence for Freescale SPI format with `SPO=1` and `SPH=1` is shown in Figure 20-9 on page 1363, which covers both single and continuous transfers.

Note: This Freescale SPI frame format configuration is only available when operating in Legacy SSI mode of operation.

Figure 20-9. Freescale SPI Frame Format with `SPO=1` and `SPH=1`

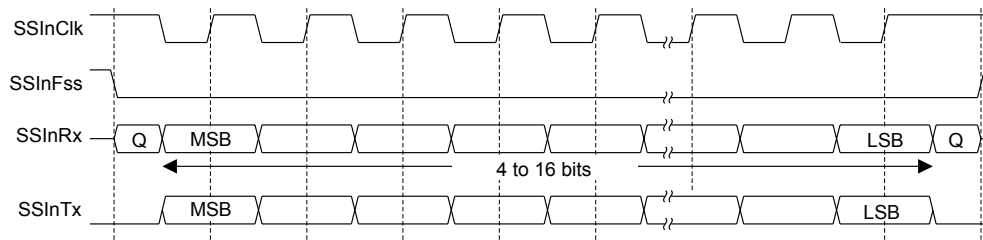

Note: Q is undefined.

In this configuration, during idle periods:

- `SSInClk` is forced High
- `SSInFss` is forced High
- The transmit data line `SSInDAT0/SSInTX` is tristated
- When the QSSI is configured as a master, it enables the `SSInClk` pad
- When the QSSI is configured as a slave, it disables the `SSInClk` pad

If the QSSI is enabled and valid data is in the transmit FIFO, the start of transmission is signified by the `SSInFss` master signal being driven Low. The master `SSInDAT0/SSInTX` output pad is enabled. After an additional one-half `SSInClk` period, both master and slave data are enabled onto their respective transmission lines. At the same time, `SSInClk` is enabled with a falling edge transition. Data is then captured on the rising edges and propagated on the falling edges of the `SSInClk` signal.

After all bits have been transferred, in the case of a single word transmission, the `SSInFss` line is returned to its idle high state one `SSInClk` period after the last bit has been captured.

For continuous back-to-back transmissions, the `SSInFss` pin remains in its active Low state until the final bit of the last word has been captured and then returns to its idle state as described above.

For continuous back-to-back transfers, the `SSInFss` pin is held Low between successive data words and termination is the same as that of the single word transfer.

20.3.8 DMA Operation

The QSSI peripheral provides an interface to the μ DMA controller with separate channels for transmit and receive. The μ DMA operation of the QSSI is enabled through the **SSI DMA Control (SSIDMACTL)** register. When μ DMA operation is enabled, the QSSI asserts a μ DMA request on the receive or transmit channel when the associated FIFO can transfer data.

For the receive channel, a single transfer request is asserted whenever any data is in the receive FIFO. A burst transfer request is asserted whenever the amount of data in the receive FIFO is 4 or more items. For the transmit channel, a single transfer request is asserted whenever at least one empty location is in the transmit FIFO. The burst request is asserted whenever the transmit FIFO has 4 or more empty slots. The single and burst μ DMA transfer requests are handled automatically by the μ DMA controller depending how the μ DMA channel is configured.

To enable μ DMA operation for the receive channel, the `RXDMAE` bit of the **DMA Control (SSIDMACTL)** register should be set after configuring the μ DMA. To enable μ DMA operation for the transmit channel, the `TXDMAE` bit of **SSIDMACTL** should be set after configuring the μ DMA.

If the μ DMA is enabled and has completed a data transfer from the Tx FIFO, the `DMATXRIS` bit is set in the **SSIRIS** register and cannot be cleared by setting the `DMATXIC` bit in the **SSI Interrupt Clear (SSIICR)** register. In the DMA Completion Interrupt Service Routine, software must disable the μ DMA transmit enable to the SSI by clearing the `TXDMAE` bit in the **QSSI DMA Control (SSIDMACTL)** register and then setting the `DMATXIC` bit in the **SSIICR** register. This clears the DMA completion interrupt. When the μ DMA is needed to transmit more data, the `TXDMAE` bit must be set (enabled) again.

If a data transfer by the μ DMA from the Rx FIFO completes, the `DMARXRIS` bit is set. The `EOT` bit in the **SSIRIS** register is also provided to indicate when the Tx FIFO is empty and the last bit has been transmitted out of the serializer.

Note: Wait states are inserted at every byte transfer when using Bi- or Quad-SSI modes as a master with the μ DMA at `SSICLK` frequencies greater than 1/6 of the system clock. These wait states are because of arbitration stall cycles from the μ DMA accesses to SRAM and increased output throughput from the SSI.

See "Micro Direct Memory Access (μ DMA)" on page 686 for more details about programming the μ DMA controller.

20.4 Initialization and Configuration

To enable and initialize the QSSI, the following steps are necessary:

1. Enable the QSSI module using the **RCGCSSI** register (see page 397).
2. Enable the clock to the appropriate GPIO module via the **RCGCGPIO** register (see page 389). To find out which GPIO port to enable, refer to Table 29-5 on page 1932.
3. Set the GPIO **AFSEL** bits for the appropriate pins (see page 778). To determine which GPIOs to configure, see Table 29-4 on page 1921.
4. Configure the **PMCn** fields in the **GPIOPCTL** register to assign the QSSI signals to the appropriate pins. See page 795 and Table 29-5 on page 1932.
5. Program the **GPIODEN** register to enable the pin's digital function. In addition, the drive strength, drain select and pull-up/pull-down functions must be configured. Refer to “General-Purpose Input/Outputs (GPIOs)” on page 750 for more information.

Note: Pull-ups can be used to avoid unnecessary toggles on the QSSI pins, which can take the slave to a wrong state. In addition, if the **SSIClk** signal is programmed to steady state High through the **SPO** bit in the **SSICR0** register, then software must also configure the GPIO port pin corresponding to the **SSInClk** signal as a pull-up in the **GPIO Pull-Up Select (GPIOPUR)** register.

For each of the frame formats, the QSSI is configured using the following steps:

1. If initializing out of reset, ensure that the **SSE** bit in the **SSICR1** register is clear before making any configuration changes. Otherwise, configuration changes for Advanced SSI can be made while the **SSE** bit is set.
2. Select whether the QSSI is a master or slave:
 - a. For master operations, set the **SSICR1** register to 0x0000.0000.
 - b. For slave mode (output enabled), set the **SSICR1** register to 0x0000.0004.
 - c. For slave mode (output disabled), set the **SSICR1** register to 0x0000.000C.
3. Configure the QSSI clock source by writing to the **SSICC** register.
4. Configure the clock prescale divisor by writing the **SSICPSR** register.
5. Write the **SSICR0** register with the following configuration:
 - Serial clock rate (**SCR**)
 - Desired clock phase/polarity, if using Freescale SPI mode (**SPH** and **SPO**)
 - The protocol mode: Freescale SPI or TI SSF
 - The data size (**DSS**)
6. Optionally, configure the SSI module for μ DMA use with the following steps:
 - a. Configure a μ DMA for SSI use. See “Micro Direct Memory Access (μ DMA)” on page 686 for more information.
 - b. Enable the SSI Module's TX FIFO or RX FIFO by setting the **TXDMAE** or **RXDMAE** bit in the **SSIDMACTL** register.

- c. Optionally, enable the μ DMA completion interrupt by setting the `DMATXIM` or `DMARXIM` bit in the **SSIIM** register.

Note: For a TX DMA completion interrupt, software must disable the μ DMA transmit enable to the SSI by clearing the `TXDMAE` bit in the **QSSI DMA Control (SSIDMACTL)** register and then setting the `DMATXIC` bit in the **SSIICR** register. This clears the DMA completion interrupt. When the μ DMA is needed to transmit more data, the `TXDMAE` bit must be set (enabled) again.

7. If this is the first initialization out of reset, enable the QSSI by setting the `SSE` bit in the **SSICR1** register.

As an example, assume the QSSI must be configured to operate with the following parameters:

- Master operation
- Freescale SPI mode (`SPO=1`, `SPH=1`)
- 1 Mbps bit rate
- 8 data bits

Assuming the system clock is 20 MHz, the bit rate calculation would be:

$$\begin{aligned} \text{SSInClk} &= \text{SysClk} / (\text{CPSDVSR} * (1 + \text{SCR})) \\ 1 \times 10^6 &= 20 \times 10^6 / (\text{CPSDVSR} * (1 + \text{SCR})) \end{aligned}$$

In this case, if `CPSDVSR=0x2`, `SCR` must be `0x9`.

The configuration sequence would be as follows:

1. Ensure that the `SSE` bit in the **SSICR1** register is clear.
2. Write the **SSICR1** register with a value of `0x0000.0000`.
3. Write the **SSICPSR** register with a value of `0x0000.0002`.
4. Write the **SSICR0** register with a value of `0x0000.09C7`.
5. The QSSI is then enabled by setting the `SSE` bit in the **SSICR1** register.

20.4.1 Enhanced Mode Configuration

If the QSSI module supports the Advanced/Bi-/Quad features, then these modes can be enabled after initializing the QSSI module. Below is an example of configuring the QSSI to transmit two data bytes in Advanced SSI mode followed by 2 bytes in Bi-SSI mode:

1. Set the `MODE` bit to `0x3`, and the `FSSHLDLFM` bit to 1 in the **SSICR1** register. To operate in the master mode, program the `MS` bit to 0. Program the remaining bits in the **SSICR0** and **SSICR1** register to relevant values.
2. Write one data byte to the TX FIFO; set the `EOM` bit to 1 and write the second data byte to the TX FIFO.

3. Set the `MODE` bit to 0x1 and the `FSSHLDPM` bit to 1 in the **SSICR1** register. To operate in the master mode, program the `MS` bit to 0. Program the remaining bits in the **SSICR0** and **SSICR1** register to relevant values.
4. Fill the Tx FIFO with one data byte.
5. Set the `EOM` bit in the **SSICR1** register.
6. Fill the Tx FIFO with one data byte.

20.5 Register Map

Table 20-5 on page 1367 lists the QSSI registers. The offset listed is a hexadecimal increment to the register's address, relative to that QSSI module's base address:

- QSSI0: 0x4000.8000
- QSSI1: 0x4000.9000
- QSSI2: 0x4000.A000
- QSSI3: 0x4000.B000

Note that the QSSI module clock must be enabled before the registers can be programmed (see page 397). The `Rn` bit of the **PRSSI** register must be read as 0x1 before any QSSI module registers are accessed.

Table 20-5. SSI Register Map

Offset	Name	Type	Reset	Description	See page
0x000	SSICR0	RW	0x0000.0000	QSSI Control 0	1369
0x004	SSICR1	RW	0x0000.0000	QSSI Control 1	1371
0x008	SSIDR	RW	0x0000.0000	QSSI Data	1373
0x00C	SSISR	RO	0x0000.0003	QSSI Status	1374
0x010	SSICPSR	RW	0x0000.0000	QSSI Clock Prescale	1376
0x014	SSIIM	RW	0x0000.0000	QSSI Interrupt Mask	1377
0x018	SSIRIS	RO	0x0000.0008	QSSI Raw Interrupt Status	1379
0x01C	SSIMIS	RO	0x0000.0000	QSSI Masked Interrupt Status	1381
0x020	SSIICR	W1C	0x0000.0000	QSSI Interrupt Clear	1383
0x024	SSIDMACTL	RW	0x0000.0000	QSSI DMA Control	1384
0xFC0	SSIPP	RO	0x0000.000D	QSSI Peripheral Properties	1385
0xFC8	SSICC	RW	0x0000.0000	QSSI Clock Configuration	1386
0xFD0	SSIPeriphID4	RO	0x0000.0000	QSSI Peripheral Identification 4	1387
0xFD4	SSIPeriphID5	RO	0x0000.0000	QSSI Peripheral Identification 5	1388
0xFD8	SSIPeriphID6	RO	0x0000.0000	QSSI Peripheral Identification 6	1389
0xFDC	SSIPeriphID7	RO	0x0000.0000	QSSI Peripheral Identification 7	1390
0xFE0	SSIPeriphID0	RO	0x0000.0022	QSSI Peripheral Identification 0	1391

Table 20-5. SSI Register Map (continued)

Offset	Name	Type	Reset	Description	See page
0xFE4	SSIPeriphID1	RO	0x0000.0000	QSSI Peripheral Identification 1	1392
0xFE8	SSIPeriphID2	RO	0x0000.0018	QSSI Peripheral Identification 2	1393
0xFEC	SSIPeriphID3	RO	0x0000.0001	QSSI Peripheral Identification 3	1394
0xFF0	SSIPCellID0	RO	0x0000.000D	QSSI PrimeCell Identification 0	1395
0xFF4	SSIPCellID1	RO	0x0000.00F0	QSSI PrimeCell Identification 1	1396
0xFF8	SSIPCellID2	RO	0x0000.0005	QSSI PrimeCell Identification 2	1397
0xFFC	SSIPCellID3	RO	0x0000.00B1	QSSI PrimeCell Identification 3	1398

20.6 Register Descriptions

The remainder of this section lists and describes the QSSI registers, in numerical order by address offset.

Register 1: QSSI Control 0 (SSICR0), offset 0x000

The **SSICR0** register contains bit fields that control various functions within the QSSI module. Functionality such as protocol mode, clock rate, and data size are configured in this register.

QSSI Control 0 (SSICR0)

QSSI0 base: 0x4000.8000
 QSSI1 base: 0x4000.9000
 QSSI2 base: 0x4000.A000
 QSSI3 base: 0x4000.B000
 Offset 0x000
 Type RW, reset 0x0000.0000

	31	30	29	28	27	26	25	24	23	22	21	20	19	18	17	16
	reserved															
Type	RO	RO	RO	RO	RO	RO	RO	RO	RO	RO	RO	RO	RO	RO	RO	RO
Reset	0	0	0	0	0	0	0	0	0	0	0	0	0	0	0	0
	15	14	13	12	11	10	9	8	7	6	5	4	3	2	1	0
	SCR								SPH		SPO		FRF		DSS	
Type	RW	RW	RW	RW	RW	RW	RW	RW	RW	RW	RW	RW	RW	RW	RW	RW
Reset	0	0	0	0	0	0	0	0	0	0	0	0	0	0	0	0

Bit/Field	Name	Type	Reset	Description						
31:16	reserved	RO	0x0000	Software should not rely on the value of a reserved bit. To provide compatibility with future products, the value of a reserved bit should be preserved across a read-modify-write operation.						
15:8	SCR	RW	0x00	<p>QSSI Serial Clock Rate</p> <p>This bit field is used to generate the transmit and receive bit rate of the QSSI. The bit rate is:</p> $BR = SysClk / (CPSDVSR * (1 + SCR))$ <p>where CPSDVSR is an even value from 2-254 programmed in the SSICPSR register, and SCR is a value from 0-255.</p>						
7	SPH	RW	0	<p>QSSI Serial Clock Phase</p> <p>This bit is only applicable to the Freescale SPI Format.</p> <p>The SPH control bit selects the clock edge that captures data and allows it to change state. This bit has the most impact on the first bit transmitted by either allowing or not allowing a clock transition before the first data capture edge.</p> <table border="0"> <tr> <td>Value</td> <td>Description</td> </tr> <tr> <td>0</td> <td>Data is captured on the first clock edge transition.</td> </tr> <tr> <td>1</td> <td>Data is captured on the second clock edge transition.</td> </tr> </table>	Value	Description	0	Data is captured on the first clock edge transition.	1	Data is captured on the second clock edge transition.
Value	Description									
0	Data is captured on the first clock edge transition.									
1	Data is captured on the second clock edge transition.									
6	SPO	RW	0	<p>QSSI Serial Clock Polarity</p> <table border="0"> <tr> <td>Value</td> <td>Description</td> </tr> <tr> <td>0</td> <td>A steady state Low value is placed on the SSInClk pin.</td> </tr> <tr> <td>1</td> <td>A steady state High value is placed on the SSInClk pin when data is not being transferred.</td> </tr> </table> <p>Note: If this bit is set, then software must also configure the GPIO port pin corresponding to the SSInClk signal as a pull-up in the GPIO Pull-Up Select (GPIOPUR) register.</p>	Value	Description	0	A steady state Low value is placed on the SSInClk pin.	1	A steady state High value is placed on the SSInClk pin when data is not being transferred.
Value	Description									
0	A steady state Low value is placed on the SSInClk pin.									
1	A steady state High value is placed on the SSInClk pin when data is not being transferred.									

Bit/Field	Name	Type	Reset	Description
5:4	FRF	RW	0x0	<p>QSSI Frame Format Select</p> <p>Note: When operating in Advanced/Bi-/Quad-SSI mode these bits must be programmed to 0x0 (Freescale SPI Frame Format).</p> <p>Value Frame Format</p> <p>0x0 Freescale SPI Frame Format</p> <p>0x1 Texas Instruments Synchronous Serial Frame Format</p> <p>0x2-0x3 Reserved</p>
3:0	DSS	RW	0x0	<p>QSSI Data Size Select</p> <p>Note: When operating in Advanced, Bi- or Quad-SSI, data size can only be 8-bit. All other fields will be ignored.</p> <p>Value Data Size</p> <p>0x0-0x2 Reserved</p> <p>0x3 4-bit data</p> <p>0x4 5-bit data</p> <p>0x5 6-bit data</p> <p>0x6 7-bit data</p> <p>0x7 8-bit data</p> <p>0x8 9-bit data</p> <p>0x9 10-bit data</p> <p>0xA 11-bit data</p> <p>0xB 12-bit data</p> <p>0xC 13-bit data</p> <p>0xD 14-bit data</p> <p>0xE 15-bit data</p> <p>0xF 16-bit data</p>

Register 2: QSSI Control 1 (SSICR1), offset 0x004

The **SSICR1** register contains bit fields that control various functions within the QSSI module. Master and slave mode functionality is controlled by this register.

QSSI Control 1 (SSICR1)

QSSI0 base: 0x4000.8000
 QSSI1 base: 0x4000.9000
 QSSI2 base: 0x4000.A000
 QSSI3 base: 0x4000.B000
 Offset 0x004
 Type RW, reset 0x0000.0000

	31	30	29	28	27	26	25	24	23	22	21	20	19	18	17	16		
	reserved																	
Type	RO	RO	RO	RO	RO	RO	RO	RO	RO	RO	RO	RO	RO	RO	RO	RO		
Reset	0	0	0	0	0	0	0	0	0	0	0	0	0	0	0	0		
	15	14	13	12	11	10	9	8	7	6	5	4	3	2	1	0		
	reserved				EOM	FSSHLDFRM	HSCLKEN	DIR	MODE				reserved			MS	SSE	LBM
Type	RO	RO	RO	RO	RW	RW	RW	RW	RW	RW	RO	RO	RO	RW	RW	RW		
Reset	0	0	0	0	0	0	0	0	0	0	0	0	0	0	0	0		

Bit/Field	Name	Type	Reset	Description						
31:12	reserved	RO	0x0000.0	Software should not rely on the value of a reserved bit. To provide compatibility with future products, the value of a reserved bit should be preserved across a read-modify-write operation.						
11	EOM	RW	0	<p>Stop Frame (End of Message)</p> <p>This bit is applicable when MODE is set to Advanced, Bi- or Quad- SSI. This bit is inserted into bit 12 of the TXFIFO data entry by the QSSI module.</p> <p>Value Description</p> <table border="1"> <tr> <th>Value</th> <th>Description</th> </tr> <tr> <td>0</td> <td>No change in transmission status.</td> </tr> <tr> <td>1</td> <td>End of message (Stop Frame).</td> </tr> </table>	Value	Description	0	No change in transmission status.	1	End of message (Stop Frame).
Value	Description									
0	No change in transmission status.									
1	End of message (Stop Frame).									
10	FSSHLDFRM	RW	0	<p>FSS Hold Frame</p> <p>Value Description</p> <table border="1"> <tr> <th>Value</th> <th>Description</th> </tr> <tr> <td>0</td> <td>Pulse $SSInFss$ at every byte (the DSS bit in the SSICR0 register must be set to 0x7 (data size 8 bits) in this configuration)</td> </tr> <tr> <td>1</td> <td>Hold $SSInFss$ for the whole frame</td> </tr> </table>	Value	Description	0	Pulse $SSInFss$ at every byte (the DSS bit in the SSICR0 register must be set to 0x7 (data size 8 bits) in this configuration)	1	Hold $SSInFss$ for the whole frame
Value	Description									
0	Pulse $SSInFss$ at every byte (the DSS bit in the SSICR0 register must be set to 0x7 (data size 8 bits) in this configuration)									
1	Hold $SSInFss$ for the whole frame									
9	HSCLKEN	RW	0	<p>High Speed Clock Enable</p> <p>High speed clock enable is available only when operating as a master.</p> <p>Value Description</p> <table border="1"> <tr> <th>Value</th> <th>Description</th> </tr> <tr> <td>0</td> <td>Use Input Clock</td> </tr> <tr> <td>1</td> <td>Use High Speed Clock</td> </tr> </table> <p>Note: For proper functionality of high speed mode, the HSCLKEN bit in the SSICR1 register should be set before any SSI data transfer or after applying a reset to the QSSI module. In addition, the SSE bit must be set to 0x1 before the HSCLKEN bit is set.</p>	Value	Description	0	Use Input Clock	1	Use High Speed Clock
Value	Description									
0	Use Input Clock									
1	Use High Speed Clock									

Bit/Field	Name	Type	Reset	Description
8	DIR	RW	0	<p>QSSI Direction of Operation</p> <p>Value Description</p> <p>0 TX (Transmit Mode) write direction</p> <p>1 RX (Receive Mode) read direction</p>
7:6	MODE	RW	0x0	<p>QSSI Mode</p> <p>Value Description</p> <p>0x0 Legacy SSI mode</p> <p>0x1 Bi-SSI mode</p> <p>0x2 Quad-SSI Mode</p> <p>0x3 Advanced SSI Mode with 8-bit packet size</p>
5:3	reserved	RO	0	Software should not rely on the value of a reserved bit. To provide compatibility with future products, the value of a reserved bit should be preserved across a read-modify-write operation.
2	MS	RW	0	<p>QSSI Master/Slave Select</p> <p>This bit selects Master or Slave mode and can be modified only when the QSSI is disabled ($SSE=0$).</p> <p>Value Description</p> <p>0 The QSSI is configured as a master.</p> <p>1 The QSSI is configured as a slave.</p>
1	SSE	RW	0	<p>QSSI Synchronous Serial Port Enable</p> <p>Value Description</p> <p>0 QSSI operation is disabled.</p> <p>1 QSSI operation is enabled.</p> <p>Note: The HSCLKEN bit in the SSICR1 register should be set only after applying reset to the QSSI module and enabling the QSSI by setting the SSE bit, and before any SSI data transfer. All other bits in the SSICR1 register and all bits in SSICR0 register can only be programmed when the SSE is clear.</p>
0	LBM	RW	0	<p>QSSI Loopback Mode</p> <p>Value Description</p> <p>0 Normal serial port operation enabled.</p> <p>1 Output of the transmit serial shift register is connected internally to the input of the receive serial shift register.</p>

Register 3: QSSI Data (SSIDR), offset 0x008

Important: This register is read-sensitive. See the register description for details.

The **SSIDR** register is 16-bits wide. When the **SSIDR** register is read, the entry in the receive FIFO that is pointed to by the current FIFO read pointer is accessed. When a data value is removed by the QSSI receive logic from the incoming data frame, it is placed into the entry in the receive FIFO pointed to by the current FIFO write pointer.

When the **SSIDR** register is written to, the entry in the transmit FIFO that is pointed to by the write pointer is written to. Data values are removed from the transmit FIFO one value at a time by the transmit logic. Each data value is loaded into the transmit serial shifter, then serially shifted out onto the **SSInDAT0/SSInTX** pin at the programmed bit rate.

When a data size of less than 16 bits is selected, the user must right-justify data written to the transmit FIFO. The transmit logic ignores the unused bits. Received data less than 16 bits is automatically right-justified in the receive buffer.

QSSI Data (SSIDR)

QSSI0 base: 0x4000.8000
 QSSI1 base: 0x4000.9000
 QSSI2 base: 0x4000.A000
 QSSI3 base: 0x4000.B000
 Offset 0x008
 Type RW, reset 0x0000.0000

	31	30	29	28	27	26	25	24	23	22	21	20	19	18	17	16
	reserved															
Type	RO	RO	RO	RO	RO	RO	RO	RO	RO	RO	RO	RO	RO	RO	RO	RO
Reset	0	0	0	0	0	0	0	0	0	0	0	0	0	0	0	0
	15	14	13	12	11	10	9	8	7	6	5	4	3	2	1	0
	DATA															
Type	RW	RW	RW	RW	RW	RW	RW	RW	RW	RW	RW	RW	RW	RW	RW	RW
Reset	0	0	0	0	0	0	0	0	0	0	0	0	0	0	0	0

Bit/Field	Name	Type	Reset	Description
31:16	reserved	RO	0x0000	Software should not rely on the value of a reserved bit. To provide compatibility with future products, the value of a reserved bit should be preserved across a read-modify-write operation.
15:0	DATA	RW	0x0000	QSSI Receive/Transmit Data A read operation reads the receive FIFO. A write operation writes the transmit FIFO. Software must right-justify data when the QSSI is programmed for a data size that is less than 16 bits. Unused bits at the top are ignored by the transmit logic. The receive logic automatically right-justifies the data.

Register 4: QSSI Status (SSISR), offset 0x00C

The **SSISR** register contains bits that indicate the FIFO fill status and the QSSI busy status.

QSSI Status (SSISR)

QSSI0 base: 0x4000.8000
 QSSI1 base: 0x4000.9000
 QSSI2 base: 0x4000.A000
 QSSI3 base: 0x4000.B000
 Offset 0x00C
 Type RO, reset 0x0000.0003



Bit/Field	Name	Type	Reset	Description
31:5	reserved	RO	0x0000.00	Software should not rely on the value of a reserved bit. To provide compatibility with future products, the value of a reserved bit should be preserved across a read-modify-write operation.
4	BSY	RO	0	QSSI Busy Bit Value Description 0 The QSSI is idle. 1 The QSSI is currently transmitting and/or receiving a frame, or the transmit FIFO is not empty.
3	RFF	RO	0	QSSI Receive FIFO Full Value Description 0 The receive FIFO is not full. 1 The receive FIFO is full.
2	RNE	RO	0	QSSI Receive FIFO Not Empty Value Description 0 The receive FIFO is empty. 1 The receive FIFO is not empty.
1	TNF	RO	1	QSSI Transmit FIFO Not Full Value Description 0 The transmit FIFO is full. 1 The transmit FIFO is not full.

Bit/Field	Name	Type	Reset	Description
0	TFE	RO	1	QSSI Transmit FIFO Empty
				Value Description
				0 The transmit FIFO is not empty.
				1 The transmit FIFO is empty.

Register 5: QSSI Clock Prescale (SSICPSR), offset 0x010

The **SSICPSR** register specifies the division factor which is used to derive the **SSInClk** from the system clock. The clock is further divided by a value from 1 to 256, which is $1 + SCR$. **SCR** is programmed in the **SSICR0** register. The frequency of the **SSInClk** is defined by:

$$SSInClk = SysClk / (CPSDVSR * (1 + SCR))$$

The value programmed into this register must be an even number between 2 and 254. The least-significant bit of the programmed number is hard-coded to zero. If an odd number is written to this register, data read back from this register has the least-significant bit as zero.

QSSI Clock Prescale (SSICPSR)

QSSI0 base: 0x4000.8000
 QSSI1 base: 0x4000.9000
 QSSI2 base: 0x4000.A000
 QSSI3 base: 0x4000.B000
 Offset 0x010
 Type RW, reset 0x0000.0000

	31	30	29	28	27	26	25	24	23	22	21	20	19	18	17	16
	reserved															
Type	RO	RO	RO	RO	RO	RO	RO	RO	RO	RO	RO	RO	RO	RO	RO	RO
Reset	0	0	0	0	0	0	0	0	0	0	0	0	0	0	0	0
	15	14	13	12	11	10	9	8	7	6	5	4	3	2	1	0
	reserved								CPSDVSR							
Type	RO	RO	RO	RO	RO	RO	RO	RO	RW	RW	RW	RW	RW	RW	RW	RW
Reset	0	0	0	0	0	0	0	0	0	0	0	0	0	0	0	0

Bit/Field	Name	Type	Reset	Description
31:8	reserved	RO	0x00	Software should not rely on the value of a reserved bit. To provide compatibility with future products, the value of a reserved bit should be preserved across a read-modify-write operation.
7:0	CPSDVSR	RW	0x00	QSSI Clock Prescale Divisor This value must be an even number from 2 to 254, depending on the frequency of SSInClk . The LSB always returns 0 on reads.

Register 6: QSSI Interrupt Mask (SSIIM), offset 0x014

The **SSIIM** register is the interrupt mask set or clear register. It is a read/write register and all bits are cleared on reset.

On a read, this register gives the current value of the mask on the corresponding interrupt. Setting a bit clears the mask, enabling the interrupt to be sent to the interrupt controller. Clearing a bit sets the corresponding mask, preventing the interrupt from being signaled to the controller.

QSSI Interrupt Mask (SSIIM)

QSSI0 base: 0x4000.8000
 QSSI1 base: 0x4000.9000
 QSSI2 base: 0x4000.A000
 QSSI3 base: 0x4000.B000
 Offset 0x014
 Type RW, reset 0x0000.0000

	31	30	29	28	27	26	25	24	23	22	21	20	19	18	17	16	
	reserved																
Type	RO	RO	RO	RO	RO	RO	RO	RO	RO	RO	RO	RO	RO	RO	RO	RO	
Reset	0	0	0	0	0	0	0	0	0	0	0	0	0	0	0	0	
	15	14	13	12	11	10	9	8	7	6	5	4	3	2	1	0	
	reserved										EOTIM	DMATXIM	DMARXIM	TXIM	RXIM	RTIM	RORIM
Type	RO	RO	RO	RO	RO	RO	RO	RO	RO	RO	RW	RW	RW	RW	RW	RW	
Reset	0	0	0	0	0	0	0	0	0	0	0	0	0	0	0	0	

Bit/Field	Name	Type	Reset	Description
31:7	reserved	RO	0	Software should not rely on the value of a reserved bit. To provide compatibility with future products, the value of a reserved bit should be preserved across a read-modify-write operation.
6	EOTIM	RW	0	End of Transmit Interrupt Mask Value Description 0 The end of transmit interrupt is masked. 1 The end of transmit interrupt is not masked.
5	DMATXIM	RW	0	QSSI Transmit DMA Interrupt Mask Value Description 0 The transmit DMA interrupt is masked. 1 The transmit DMA interrupt is not masked.
4	DMARXIM	RW	0	QSSI Receive DMA Interrupt Mask Value Description 0 The receive DMA interrupt is masked. 1 The receive DMA interrupt is not masked.
3	TXIM	RW	0	QSSI Transmit FIFO Interrupt Mask Value Description 0 The transmit FIFO interrupt is masked. 1 The transmit FIFO interrupt is not masked.

Bit/Field	Name	Type	Reset	Description
2	RXIM	RW	0	QSSI Receive FIFO Interrupt Mask Value Description 0 The receive FIFO interrupt is masked. 1 The receive FIFO interrupt is not masked.
1	RTIM	RW	0	QSSI Receive Time-Out Interrupt Mask Value Description 0 The receive FIFO time-out interrupt is masked. 1 The receive FIFO time-out interrupt is not masked.
0	RORIM	RW	0	QSSI Receive Overrun Interrupt Mask Value Description 0 The receive FIFO overrun interrupt is masked. 1 The receive FIFO overrun interrupt is not masked.

Register 7: QSSI Raw Interrupt Status (SSIRIS), offset 0x018

The **SSIRIS** register is the raw interrupt status register. On a read, this register gives the current raw status value of the corresponding interrupt prior to masking. A write has no effect.

QSSI Raw Interrupt Status (SSIRIS)

QSSI0 base: 0x4000.8000
 QSSI1 base: 0x4000.9000
 QSSI2 base: 0x4000.A000
 QSSI3 base: 0x4000.B000
 Offset 0x018
 Type RO, reset 0x0000.0008

	31	30	29	28	27	26	25	24	23	22	21	20	19	18	17	16	
	reserved																
Type	RO	RO	RO	RO	RO	RO	RO	RO	RO	RO	RO	RO	RO	RO	RO	RO	
Reset	0	0	0	0	0	0	0	0	0	0	0	0	0	0	0	0	
	15	14	13	12	11	10	9	8	7	6	5	4	3	2	1	0	
	reserved										EOTRIS	DMATXRIS	DMARXRIS	TXRIS	RXRIS	RTRIS	RORRIS
Type	RO	RO	RO	RO	RO	RO	RO	RO	RO	RO	RO	RO	RO	RO	RO	RO	
Reset	0	0	0	0	0	0	0	0	0	0	0	0	0	1	0	0	

Bit/Field	Name	Type	Reset	Description
31:7	reserved	RO	0	Software should not rely on the value of a reserved bit. To provide compatibility with future products, the value of a reserved bit should be preserved across a read-modify-write operation.
6	EOTRIS	RO	0	End of Transmit Raw Interrupt Status Value Description 0 No interrupt. 1 The transmit FIFO is empty, and the last bit has been transmitted out of the serializer. This bit is cleared when a 1 is written to the <code>EOTIC</code> bit in the SSI Interrupt Clear (SSIICR) register.
5	DMATXRIS	RO	0	QSSI Transmit DMA Raw Interrupt Status Value Description 0 No interrupt. 1 The transmit DMA has completed. This bit is cleared when a 1 is written to the <code>DMATXIC</code> bit in the SSI Interrupt Clear (SSIICR) register.
4	DMARXRIS	RO	0	QSSI Receive DMA Raw Interrupt Status Value Description 0 No interrupt. 1 The receive DMA has completed. This bit is cleared when a 1 is written to the <code>DMARXIC</code> bit in the SSI Interrupt Clear (SSIICR) register.

Bit/Field	Name	Type	Reset	Description
3	TXRIS	RO	1	<p>QSSI Transmit FIFO Raw Interrupt Status</p> <p>Value Description</p> <p>0 No interrupt.</p> <p>1 The transmit FIFO is half empty or less.</p> <p>This bit is cleared when the transmit FIFO is more than half full.</p>
2	RXRIS	RO	0	<p>QSSI Receive FIFO Raw Interrupt Status</p> <p>Value Description</p> <p>0 No interrupt.</p> <p>1 The receive FIFO is half full or more.</p> <p>This bit is cleared when the receive FIFO is less than half full.</p>
1	RTRIS	RO	0	<p>QSSI Receive Time-Out Raw Interrupt Status</p> <p>Value Description</p> <p>0 No interrupt.</p> <p>1 The receive time-out has occurred.</p> <p>This bit is cleared when a 1 is written to the <code>RTIC</code> bit in the SSI Interrupt Clear (SSIICR) register.</p>
0	RORRIS	RO	0	<p>QSSI Receive Overrun Raw Interrupt Status</p> <p>Value Description</p> <p>0 No interrupt.</p> <p>1 The receive FIFO has overflowed</p> <p>This bit is cleared when a 1 is written to the <code>RORIC</code> bit in the SSI Interrupt Clear (SSIICR) register.</p>

Register 8: QSSI Masked Interrupt Status (SSIMIS), offset 0x01C

The **SSIMIS** register is the masked interrupt status register. On a read, this register gives the current masked status value of the corresponding interrupt. A write has no effect.

QSSI Masked Interrupt Status (SSIMIS)

QSSI0 base: 0x4000.8000
 QSSI1 base: 0x4000.9000
 QSSI2 base: 0x4000.A000
 QSSI3 base: 0x4000.B000
 Offset 0x01C
 Type RO, reset 0x0000.0000

	31	30	29	28	27	26	25	24	23	22	21	20	19	18	17	16	
	reserved																
Type	RO	RO	RO	RO	RO	RO	RO	RO	RO	RO	RO	RO	RO	RO	RO	RO	
Reset	0	0	0	0	0	0	0	0	0	0	0	0	0	0	0	0	
	15	14	13	12	11	10	9	8	7	6	5	4	3	2	1	0	
	reserved										EOTMIS	DMATXMIS	DMARXMIS	TXMIS	RXMIS	RTMIS	RORMIS
Type	RO	RO	RO	RO	RO	RO	RO	RO	RO	RO	RO	RO	RO	RO	RO	RO	
Reset	0	0	0	0	0	0	0	0	0	0	0	0	0	0	0	0	

Bit/Field	Name	Type	Reset	Description
31:7	reserved	RO	0	Software should not rely on the value of a reserved bit. To provide compatibility with future products, the value of a reserved bit should be preserved across a read-modify-write operation.
6	EOTMIS	RO	0	End of Transmit Masked Interrupt Status Value Description 0 An interrupt has not occurred or is masked. 1 An unmasked interrupt was signaled due to the transmission of the last data bit. This bit is cleared when a 1 is written to the <code>EOTIC</code> bit in the SSI Interrupt Clear (SSIICR) register.
5	DMATXMIS	RO	0	QSSI Transmit DMA Masked Interrupt Status Value Description 0 An interrupt has not occurred or is masked. 1 An unmasked interrupt was signaled due to the completion of the transmit DMA. This bit is cleared when a 1 is written to the <code>DMATXIC</code> bit in the SSI Interrupt Clear (SSIICR) register.
4	DMARXMIS	RO	0	QSSI Receive DMA Masked Interrupt Status Value Description 0 An interrupt has not occurred or is masked. 1 An unmasked interrupt was signaled due to the completion of the receive DMA. This bit is cleared when a 1 is written to the <code>DMARXIC</code> bit in the SSI Interrupt Clear (SSIICR) register.

Bit/Field	Name	Type	Reset	Description
3	TXMIS	RO	0	<p>QSSI Transmit FIFO Masked Interrupt Status</p> <p>Value Description</p> <p>0 An interrupt has not occurred or is masked.</p> <p>1 An unmasked interrupt was signaled due to the transmit FIFO being half empty or less.</p> <p>This bit is cleared when the transmit FIFO is more than half empty .</p>
2	RXMIS	RO	0	<p>QSSI Receive FIFO Masked Interrupt Status</p> <p>Value Description</p> <p>0 An interrupt has not occurred or is masked.</p> <p>1 An unmasked interrupt was signaled due to the receive FIFO being half full or more.</p> <p>This bit is cleared when the receive FIFO is less than half full.</p>
1	RTMIS	RO	0	<p>QSSI Receive Time-Out Masked Interrupt Status</p> <p>Value Description</p> <p>0 An interrupt has not occurred or is masked.</p> <p>1 An unmasked interrupt was signaled due to the receive time out.</p> <p>This bit is cleared when a 1 is written to the <code>RTIC</code> bit in the SSI Interrupt Clear (SSIICR) register.</p>
0	RORMIS	RO	0	<p>QSSI Receive Overrun Masked Interrupt Status</p> <p>Value Description</p> <p>0 An interrupt has not occurred or is masked.</p> <p>1 An unmasked interrupt was signaled due to the receive FIFO overflowing.</p> <p>This bit is cleared when a 1 is written to the <code>RORIC</code> bit in the SSI Interrupt Clear (SSIICR) register.</p>

Register 9: QSSI Interrupt Clear (SSIICR), offset 0x020

The **SSIICR** register is the interrupt clear register. On a write of 1, the corresponding interrupt is cleared. A write of 0 has no effect.

QSSI Interrupt Clear (SSIICR)

QSSI0 base: 0x4000.8000
 QSSI1 base: 0x4000.9000
 QSSI2 base: 0x4000.A000
 QSSI3 base: 0x4000.B000
 Offset 0x020
 Type W1C, reset 0x0000.0000

	31	30	29	28	27	26	25	24	23	22	21	20	19	18	17	16		
	reserved																	
Type	RO	RO	RO	RO	RO	RO	RO	RO	RO	RO	RO	RO	RO	RO	RO	RO		
Reset	0	0	0	0	0	0	0	0	0	0	0	0	0	0	0	0		
	15	14	13	12	11	10	9	8	7	6	5	4	3	2	1	0		
	reserved											EOTIC	DMATXIC	DMARXIC	reserved		RTIC	RORIC
Type	RO	RO	RO	RO	RO	RO	RO	RO	RO	RO	W1C	W1C	W1C	RO	RO	W1C	W1C	
Reset	0	0	0	0	0	0	0	0	0	0	0	0	0	0	0	0	0	

Bit/Field	Name	Type	Reset	Description
31:7	reserved	RO	0	Software should not rely on the value of a reserved bit. To provide compatibility with future products, the value of a reserved bit should be preserved across a read-modify-write operation.
6	EOTIC	W1C	0	End of Transmit Interrupt Clear Writing a 1 to this bit clears the EOTRIS bit in the SSIRIS register and the EOTMIS bit in the SSIMIS register.
5	DMATXIC	W1C	0	QSSI Transmit DMA Interrupt Clear Writing a 1 to this bit clears the DMATXRIS bit in the SSIRIS register and the DMATXMIS bit in the SSIMIS register.
4	DMARXIC	W1C	0	QSSI Receive DMA Interrupt Clear Writing a 1 to this bit clears the DMARXRIS bit in the SSIRIS register and the DMARXMIS bit in the SSIMIS register.
3:2	reserved	RO	0x0	Software should not rely on the value of a reserved bit. To provide compatibility with future products, the value of a reserved bit should be preserved across a read-modify-write operation.
1	RTIC	W1C	0	QSSI Receive Time-Out Interrupt Clear Writing a 1 to this bit clears the RTRIS bit in the SSIRIS register and the RTMIS bit in the SSIMIS register.
0	RORIC	W1C	0	QSSI Receive Overrun Interrupt Clear Writing a 1 to this bit clears the RORRIS bit in the SSIRIS register and the RORMIS bit in the SSIMIS register.

Register 10: QSSI DMA Control (SSIDMACTL), offset 0x024

The **SSIDMACTL** register is the μ DMA control register.

QSSI DMA Control (SSIDMACTL)

QSSI0 base: 0x4000.8000
 QSSI1 base: 0x4000.9000
 QSSI2 base: 0x4000.A000
 QSSI3 base: 0x4000.B000
 Offset 0x024
 Type RW, reset 0x0000.0000



Bit/Field	Name	Type	Reset	Description
31:2	reserved	RO	0x0000.000	Software should not rely on the value of a reserved bit. To provide compatibility with future products, the value of a reserved bit should be preserved across a read-modify-write operation.
1	TXDMAE	RW	0	Transmit DMA Enable Value Description 0 μ DMA for the transmit FIFO is disabled. 1 μ DMA for the transmit FIFO is enabled.
0	RXDMAE	RW	0	Receive DMA Enable Value Description 0 μ DMA for the receive FIFO is disabled. 1 μ DMA for the receive FIFO is enabled.

Register 11: QSSI Peripheral Properties (SSIPP), offset 0xFC0

The **SSIPP** register provides information regarding the properties of the QSSI module.

QSSI Peripheral Properties (SSIPP)

QSSI0 base: 0x4000.8000
 QSSI1 base: 0x4000.9000
 QSSI2 base: 0x4000.A000
 QSSI3 base: 0x4000.B000
 Offset 0xFC0
 Type RO, reset 0x0000.000D

	31	30	29	28	27	26	25	24	23	22	21	20	19	18	17	16
	reserved															
Type	RO	RO	RO	RO	RO	RO	RO	RO	RO	RO	RO	RO	RO	RO	RO	RO
Reset	0	0	0	0	0	0	0	0	0	0	0	0	0	0	0	0
	15	14	13	12	11	10	9	8	7	6	5	4	3	2	1	0
	reserved												FSSHDFRM	MODE		HCLK
Type	RO	RO	RO	RO	RO	RO	RO	RO	RO	RO	RO	RO	RO	RO	RO	RO
Reset	0	0	0	0	0	0	0	0	0	0	0	0	1	1	0	1

Bit/Field	Name	Type	Reset	Description
31:4	reserved	RO	0x0000.0000	Software should not rely on the value of a reserved bit. To provide compatibility with future products, the value of a reserved bit should be preserved across a read-modify-write operation.
3	FSSHDFRM	RO	0x1	SSInFss Hold Frame Capability Value Description 0 SSInFss Hold Frame capability disabled. 1 SSInFss Hold Frame capability enabled.
2:1	MODE	RO	0x2	Mode of Operation Indicates what QSSI functionality is supported. Value Description 0x0 Legacy SSI mode 0x1 Legacy mode, Advanced SSI mode and Bi-SSI mode enabled. 0x2 Legacy mode, Advanced mode, Bi-SSI and Quad-SSI mode enabled. 0x3 reserved
0	HCLK	RO	0x1	High Speed Capability Value Description 0 High Speed clock capability disabled. 1 High speed clock capability enabled.

Register 12: QSSI Clock Configuration (SSICC), offset 0xFC8

The **SSICC** register controls the baud clock source for the QSSI module.

Note: If ALTCLK is used for the QSSI baud clock, the system clock frequency must be at least twice that of the ALTCLK programmed value in Run mode.

QSSI Clock Configuration (SSICC)

QSSI0 base: 0x4000.8000
 QSSI1 base: 0x4000.9000
 QSSI2 base: 0x4000.A000
 QSSI3 base: 0x4000.B000
 Offset 0xFC8
 Type RW, reset 0x0000.0000



Bit/Field	Name	Type	Reset	Description										
31:4	reserved	RO	0x0000.000	Software should not rely on the value of a reserved bit. To provide compatibility with future products, the value of a reserved bit should be preserved across a read-modify-write operation.										
3:0	CS	RW	0	QSSI Baud Clock Source The following table specifies the source that generates for the QSSI baud clock: <table border="1"> <thead> <tr> <th>Value</th> <th>Description</th> </tr> </thead> <tbody> <tr> <td>0x0</td> <td>System clock (based on clock source and divisor factor programmed in RSCLKCFG register in the System Control Module)</td> </tr> <tr> <td>0x1-0x4</td> <td>reserved</td> </tr> <tr> <td>0x5</td> <td>Alternate clock source as defined by ALTCLKCFG register in System Control Module.</td> </tr> <tr> <td>0x6 - 0xF</td> <td>Reserved</td> </tr> </tbody> </table>	Value	Description	0x0	System clock (based on clock source and divisor factor programmed in RSCLKCFG register in the System Control Module)	0x1-0x4	reserved	0x5	Alternate clock source as defined by ALTCLKCFG register in System Control Module.	0x6 - 0xF	Reserved
Value	Description													
0x0	System clock (based on clock source and divisor factor programmed in RSCLKCFG register in the System Control Module)													
0x1-0x4	reserved													
0x5	Alternate clock source as defined by ALTCLKCFG register in System Control Module.													
0x6 - 0xF	Reserved													

Register 13: QSSI Peripheral Identification 4 (SSIPeriphID4), offset 0xFD0

The **SSIPeriphIDn** registers are hard-coded and the fields within the register determine the reset value.

QSSI Peripheral Identification 4 (SSIPeriphID4)

QSSI0 base: 0x4000.8000
 QSSI1 base: 0x4000.9000
 QSSI2 base: 0x4000.A000
 QSSI3 base: 0x4000.B000
 Offset 0xFD0
 Type RO, reset 0x0000.0000

	31	30	29	28	27	26	25	24	23	22	21	20	19	18	17	16
	reserved															
Type	RO	RO	RO	RO	RO	RO	RO	RO	RO	RO	RO	RO	RO	RO	RO	RO
Reset	0	0	0	0	0	0	0	0	0	0	0	0	0	0	0	0
	15	14	13	12	11	10	9	8	7	6	5	4	3	2	1	0
	reserved								PID4							
Type	RO	RO	RO	RO	RO	RO	RO	RO	RO	RO	RO	RO	RO	RO	RO	RO
Reset	0	0	0	0	0	0	0	0	0	0	0	0	0	0	0	0

Bit/Field	Name	Type	Reset	Description
31:8	reserved	RO	0x0000.00	Software should not rely on the value of a reserved bit. To provide compatibility with future products, the value of a reserved bit should be preserved across a read-modify-write operation.
7:0	PID4	RO	0x00	QSSI Peripheral ID Register [7:0] Can be used by software to identify the presence of this peripheral.

Register 14: QSSI Peripheral Identification 5 (SSIPeriphID5), offset 0xFD4

The **SSIPeriphIDn** registers are hard-coded and the fields within the register determine the reset value.

QSSI Peripheral Identification 5 (SSIPeriphID5)

QSSI0 base: 0x4000.8000
 QSSI1 base: 0x4000.9000
 QSSI2 base: 0x4000.A000
 QSSI3 base: 0x4000.B000
 Offset 0xFD4
 Type RO, reset 0x0000.0000

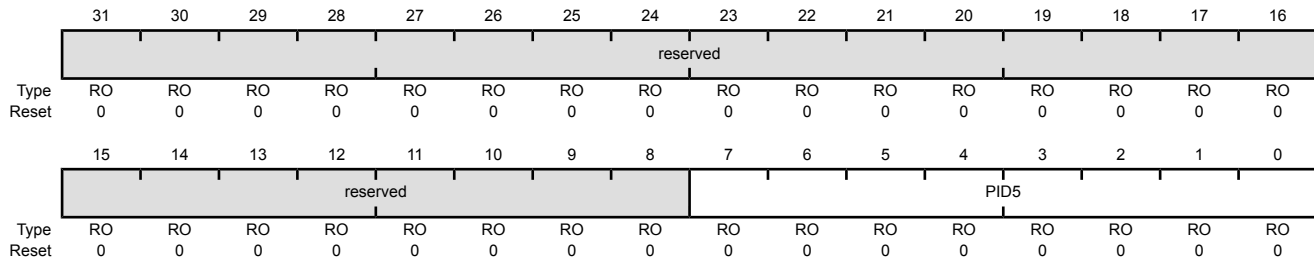

Bit/Field	Name	Type	Reset	Description
31:8	reserved	RO	0x0000.00	Software should not rely on the value of a reserved bit. To provide compatibility with future products, the value of a reserved bit should be preserved across a read-modify-write operation.
7:0	PID5	RO	0x00	QSSI Peripheral ID Register [15:8] Can be used by software to identify the presence of this peripheral.

Register 15: QSSI Peripheral Identification 6 (SSIPeriphID6), offset 0xFD8

The **SSIPeriphIDn** registers are hard-coded and the fields within the register determine the reset value.

QSSI Peripheral Identification 6 (SSIPeriphID6)

QSSI0 base: 0x4000.8000
 QSSI1 base: 0x4000.9000
 QSSI2 base: 0x4000.A000
 QSSI3 base: 0x4000.B000
 Offset 0xFD8
 Type RO, reset 0x0000.0000

	31	30	29	28	27	26	25	24	23	22	21	20	19	18	17	16
	reserved															
Type	RO	RO	RO	RO	RO	RO	RO	RO	RO	RO	RO	RO	RO	RO	RO	RO
Reset	0	0	0	0	0	0	0	0	0	0	0	0	0	0	0	0
	15	14	13	12	11	10	9	8	7	6	5	4	3	2	1	0
	reserved								PID6							
Type	RO	RO	RO	RO	RO	RO	RO	RO	RO	RO	RO	RO	RO	RO	RO	RO
Reset	0	0	0	0	0	0	0	0	0	0	0	0	0	0	0	0

Bit/Field	Name	Type	Reset	Description
31:8	reserved	RO	0x0000.00	Software should not rely on the value of a reserved bit. To provide compatibility with future products, the value of a reserved bit should be preserved across a read-modify-write operation.
7:0	PID6	RO	0x00	QSSI Peripheral ID Register [23:16] Can be used by software to identify the presence of this peripheral.

Register 16: QSSI Peripheral Identification 7 (SSIPeriphID7), offset 0xFDC

The **SSIPeriphIDn** registers are hard-coded and the fields within the register determine the reset value.

QSSI Peripheral Identification 7 (SSIPeriphID7)

QSSI0 base: 0x4000.8000
 QSSI1 base: 0x4000.9000
 QSSI2 base: 0x4000.A000
 QSSI3 base: 0x4000.B000
 Offset 0xFDC
 Type RO, reset 0x0000.0000

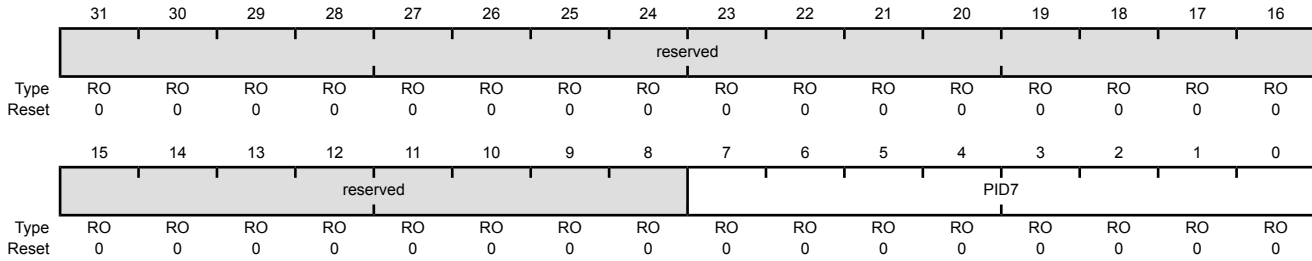

Bit/Field	Name	Type	Reset	Description
31:8	reserved	RO	0x0000.00	Software should not rely on the value of a reserved bit. To provide compatibility with future products, the value of a reserved bit should be preserved across a read-modify-write operation.
7:0	PID7	RO	0x00	QSSI Peripheral ID Register [31:24] Can be used by software to identify the presence of this peripheral.

Register 17: QSSI Peripheral Identification 0 (SSIPeriphID0), offset 0xFE0

The **SSIPeriphIDn** registers are hard-coded and the fields within the register determine the reset value.

QSSI Peripheral Identification 0 (SSIPeriphID0)

QSSI0 base: 0x4000.8000
 QSSI1 base: 0x4000.9000
 QSSI2 base: 0x4000.A000
 QSSI3 base: 0x4000.B000
 Offset 0xFE0
 Type RO, reset 0x0000.0022

	31	30	29	28	27	26	25	24	23	22	21	20	19	18	17	16
	reserved															
Type	RO	RO	RO	RO	RO	RO	RO	RO	RO	RO	RO	RO	RO	RO	RO	RO
Reset	0	0	0	0	0	0	0	0	0	0	0	0	0	0	0	0
	15	14	13	12	11	10	9	8	7	6	5	4	3	2	1	0
	reserved								PID0							
Type	RO	RO	RO	RO	RO	RO	RO	RO	RO	RO	RO	RO	RO	RO	RO	RO
Reset	0	0	0	0	0	0	0	0	0	0	1	0	0	0	1	0

Bit/Field	Name	Type	Reset	Description
31:8	reserved	RO	0x0000.00	Software should not rely on the value of a reserved bit. To provide compatibility with future products, the value of a reserved bit should be preserved across a read-modify-write operation.
7:0	PID0	RO	0x22	QSSI Peripheral ID Register [7:0] Can be used by software to identify the presence of this peripheral.

Register 18: QSSI Peripheral Identification 1 (SSIPeriphID1), offset 0xFE4

The **SSIPeriphIDn** registers are hard-coded and the fields within the register determine the reset value.

QSSI Peripheral Identification 1 (SSIPeriphID1)

QSSI0 base: 0x4000.8000
 QSSI1 base: 0x4000.9000
 QSSI2 base: 0x4000.A000
 QSSI3 base: 0x4000.B000
 Offset 0xFE4
 Type RO, reset 0x0000.0000

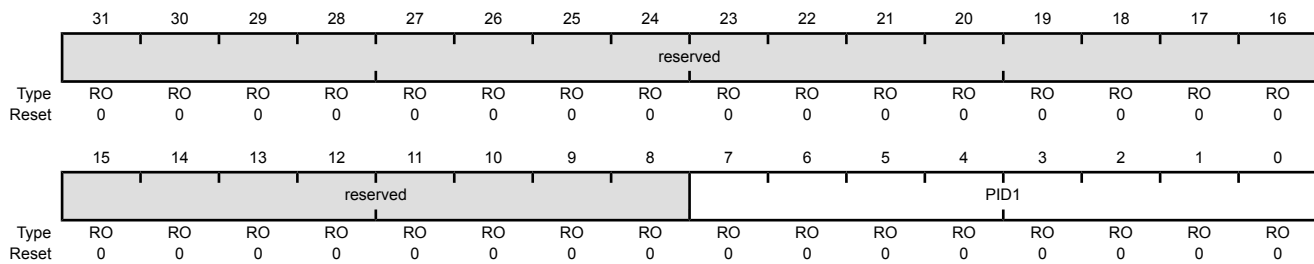

Bit/Field	Name	Type	Reset	Description
31:8	reserved	RO	0x0000.00	Software should not rely on the value of a reserved bit. To provide compatibility with future products, the value of a reserved bit should be preserved across a read-modify-write operation.
7:0	PID1	RO	0x00	QSSI Peripheral ID Register [15:8] Can be used by software to identify the presence of this peripheral.

Register 19: QSSI Peripheral Identification 2 (SSIPeriphID2), offset 0xFE8

The **SSIPeriphIDn** registers are hard-coded and the fields within the register determine the reset value.

QSSI Peripheral Identification 2 (SSIPeriphID2)

QSSI0 base: 0x4000.8000
 QSSI1 base: 0x4000.9000
 QSSI2 base: 0x4000.A000
 QSSI3 base: 0x4000.B000
 Offset 0xFE8
 Type RO, reset 0x0000.0018

	31	30	29	28	27	26	25	24	23	22	21	20	19	18	17	16
	reserved															
Type	RO	RO	RO	RO	RO	RO	RO	RO	RO	RO	RO	RO	RO	RO	RO	RO
Reset	0	0	0	0	0	0	0	0	0	0	0	0	0	0	0	0
	15	14	13	12	11	10	9	8	7	6	5	4	3	2	1	0
	reserved								PID2							
Type	RO	RO	RO	RO	RO	RO	RO	RO	RO	RO	RO	RO	RO	RO	RO	RO
Reset	0	0	0	0	0	0	0	0	0	0	0	1	1	0	0	0

Bit/Field	Name	Type	Reset	Description
31:8	reserved	RO	0x0000.00	Software should not rely on the value of a reserved bit. To provide compatibility with future products, the value of a reserved bit should be preserved across a read-modify-write operation.
7:0	PID2	RO	0x18	QSSI Peripheral ID Register [23:16] Can be used by software to identify the presence of this peripheral.

Register 20: QSSI Peripheral Identification 3 (SSIPeriphID3), offset 0xFEC

The **SSIPeriphIDn** registers are hard-coded and the fields within the register determine the reset value.

QSSI Peripheral Identification 3 (SSIPeriphID3)

QSSI0 base: 0x4000.8000
 QSSI1 base: 0x4000.9000
 QSSI2 base: 0x4000.A000
 QSSI3 base: 0x4000.B000
 Offset 0xFEC
 Type RO, reset 0x0000.0001



Bit/Field	Name	Type	Reset	Description
31:8	reserved	RO	0x0000.00	Software should not rely on the value of a reserved bit. To provide compatibility with future products, the value of a reserved bit should be preserved across a read-modify-write operation.
7:0	PID3	RO	0x01	QSSI Peripheral ID Register [31:24] Can be used by software to identify the presence of this peripheral.

Register 21: QSSI PrimeCell Identification 0 (SSIPCellID0), offset 0xFF0

The **SSIPCellIDn** registers are hard-coded, and the fields within the register determine the reset value.

QSSI PrimeCell Identification 0 (SSIPCellID0)

QSSI0 base: 0x4000.8000
 QSSI1 base: 0x4000.9000
 QSSI2 base: 0x4000.A000
 QSSI3 base: 0x4000.B000
 Offset 0xFF0
 Type RO, reset 0x0000.000D

	31	30	29	28	27	26	25	24	23	22	21	20	19	18	17	16
	reserved															
Type	RO	RO	RO	RO	RO	RO	RO	RO	RO	RO	RO	RO	RO	RO	RO	RO
Reset	0	0	0	0	0	0	0	0	0	0	0	0	0	0	0	0
	15	14	13	12	11	10	9	8	7	6	5	4	3	2	1	0
	reserved								CID0							
Type	RO	RO	RO	RO	RO	RO	RO	RO	RO	RO	RO	RO	RO	RO	RO	RO
Reset	0	0	0	0	0	0	0	0	0	0	0	0	1	1	0	1

Bit/Field	Name	Type	Reset	Description
31:8	reserved	RO	0x0000.00	Software should not rely on the value of a reserved bit. To provide compatibility with future products, the value of a reserved bit should be preserved across a read-modify-write operation.
7:0	CID0	RO	0x0D	QSSI PrimeCell ID Register [7:0] Provides software a standard cross-peripheral identification system.

Register 22: QSSI PrimeCell Identification 1 (SSIPCellID1), offset 0xFF4

The **SSIPCellIDn** registers are hard-coded, and the fields within the register determine the reset value.

QSSI PrimeCell Identification 1 (SSIPCellID1)

QSSI0 base: 0x4000.8000
 QSSI1 base: 0x4000.9000
 QSSI2 base: 0x4000.A000
 QSSI3 base: 0x4000.B000
 Offset 0xFF4
 Type RO, reset 0x0000.00F0

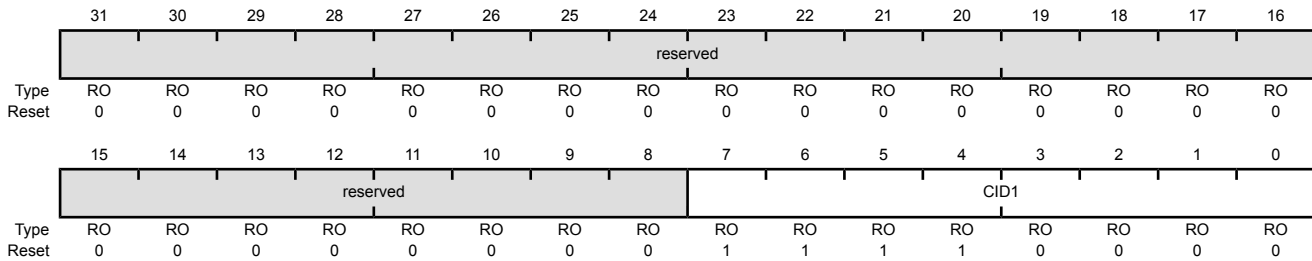

Bit/Field	Name	Type	Reset	Description
31:8	reserved	RO	0x0000.00	Software should not rely on the value of a reserved bit. To provide compatibility with future products, the value of a reserved bit should be preserved across a read-modify-write operation.
7:0	CID1	RO	0xF0	QSSI PrimeCell ID Register [15:8] Provides software a standard cross-peripheral identification system.

Register 23: QSSI PrimeCell Identification 2 (SSIPCellID2), offset 0xFF8

The **SSIPCellIDn** registers are hard-coded, and the fields within the register determine the reset value.

QSSI PrimeCell Identification 2 (SSIPCellID2)

QSSI0 base: 0x4000.8000
 QSSI1 base: 0x4000.9000
 QSSI2 base: 0x4000.A000
 QSSI3 base: 0x4000.B000
 Offset 0xFF8
 Type RO, reset 0x0000.0005

	31	30	29	28	27	26	25	24	23	22	21	20	19	18	17	16
	reserved															
Type	RO	RO	RO	RO	RO	RO	RO	RO	RO	RO	RO	RO	RO	RO	RO	RO
Reset	0	0	0	0	0	0	0	0	0	0	0	0	0	0	0	0
	15	14	13	12	11	10	9	8	7	6	5	4	3	2	1	0
	reserved								CID2							
Type	RO	RO	RO	RO	RO	RO	RO	RO	RO	RO	RO	RO	RO	RO	RO	RO
Reset	0	0	0	0	0	0	0	0	0	0	0	0	0	1	0	1

Bit/Field	Name	Type	Reset	Description
31:8	reserved	RO	0x0000.00	Software should not rely on the value of a reserved bit. To provide compatibility with future products, the value of a reserved bit should be preserved across a read-modify-write operation.
7:0	CID2	RO	0x05	QSSI PrimeCell ID Register [23:16] Provides software a standard cross-peripheral identification system.

Register 24: QSSI PrimeCell Identification 3 (SSIPCellID3), offset 0xFFC

The **SSIPCellIDn** registers are hard-coded, and the fields within the register determine the reset value.

QSSI PrimeCell Identification 3 (SSIPCellID3)

QSSI0 base: 0x4000.8000
 QSSI1 base: 0x4000.9000
 QSSI2 base: 0x4000.A000
 QSSI3 base: 0x4000.B000
 Offset 0xFFC
 Type RO, reset 0x0000.00B1

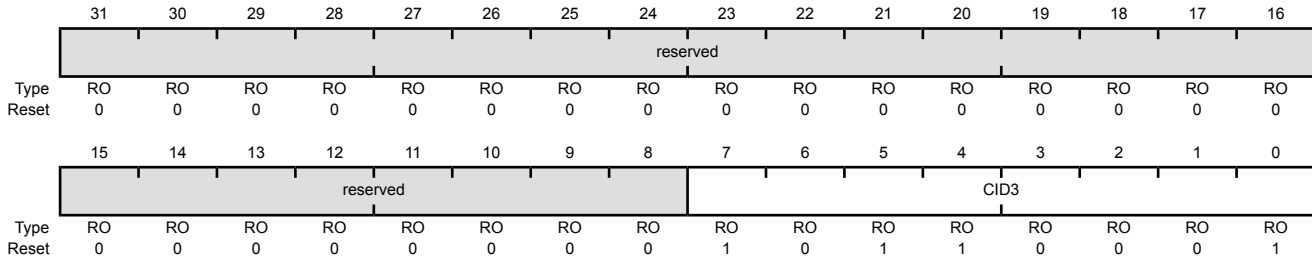

Bit/Field	Name	Type	Reset	Description
31:8	reserved	RO	0x0000.00	Software should not rely on the value of a reserved bit. To provide compatibility with future products, the value of a reserved bit should be preserved across a read-modify-write operation.
7:0	CID3	RO	0xB1	QSSI PrimeCell ID Register [31:24] Provides software a standard cross-peripheral identification system.

21 Inter-Integrated Circuit (I²C) Interface

The Inter-Integrated Circuit (I²C) bus provides bi-directional data transfer through a two-wire design (a serial data line SDA and a serial clock line SCL), and interfaces to external I²C devices such as serial memory (RAMs and ROMs), networking devices, LCDs, tone generators, and so on. The I²C bus may also be used for system testing and diagnostic purposes in product development and manufacturing. The TM4C129ENCPDT microcontroller includes providing the ability to communicate (both transmit and receive) with other I²C devices on the bus.

The TM4C129ENCPDT controller includes I²C modules with the following features:

- Devices on the I²C bus can be designated as either a master or a slave
 - Supports both transmitting and receiving data as either a master or a slave
 - Supports simultaneous master and slave operation
- Four I²C modes
 - Master transmit
 - Master receive
 - Slave transmit
 - Slave receive
- Two 8-entry FIFOs for receive and transmit data
 - FIFOs can be independently assigned to master or slave
- Four transmission speeds:
 - Standard (100 Kbps)
 - Fast-mode (400 Kbps)
 - Fast-mode plus (1 Mbps)
 - High-speed mode (3.33 Mbps)
- Glitch suppression
- SMBus support through software
 - Clock low timeout interrupt
 - Dual slave address capability
 - Quick command capability
- Master and slave interrupt generation
 - Master generates interrupts when a transmit or receive operation completes (or aborts due to an error)

- Slave generates interrupts when data has been transferred or requested by a master or when a START or STOP condition is detected
- Master with arbitration and clock synchronization, multimaster support, and 7-bit addressing mode
- Efficient transfers using Micro Direct Memory Access Controller (μDMA)
- Separate channels for transmit and receive
- Ability to execute single data transfers or burst data transfers using the RX and TX FIFOs in the I²C

21.1 Block Diagram

Figure 21-1. I²C Block Diagram

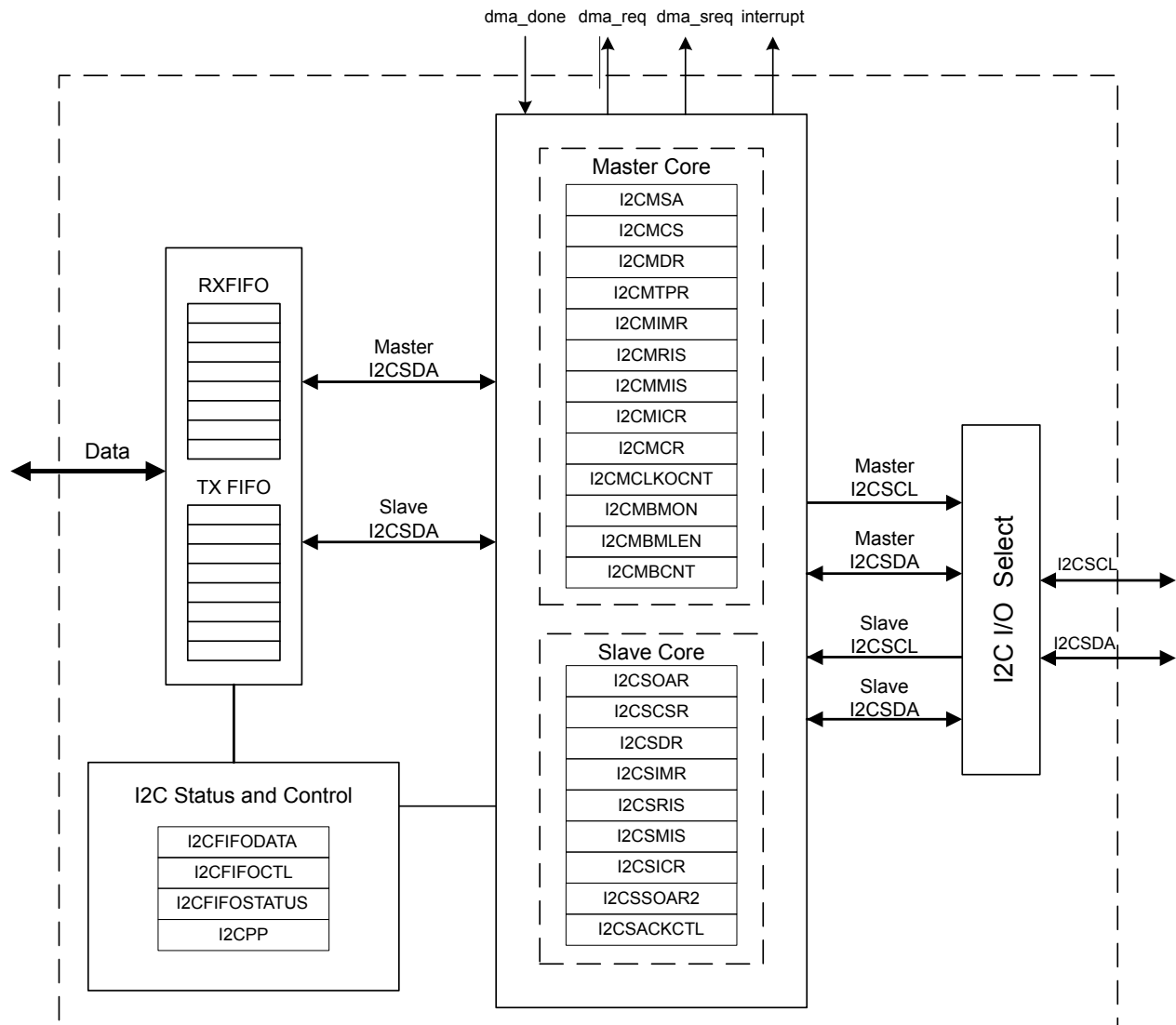

21.2 Signal Description

The following table lists the external signals of the I²C interface and describes the function of each. The I²C interface signals are alternate functions for some GPIO signals and default to be GPIO signals at reset. The column in the table below titled "Pin Mux/Pin Assignment" lists the possible GPIO pin placements for the I²C signals. The **AFSEL** bit in the **GPIO Alternate Function Select (GPIOAFSEL)** register (page 778) should be set to choose the I²C function. The number in parentheses is the encoding that must be programmed into the **PMC_n** field in the **GPIO Port Control (GPIOPTL)** register (page 795) to assign the I²C signal to the specified GPIO port pin. Note that the **I2CSDA** pin should be set to open drain using the **GPIO Open Drain Select (GPIOODR)** register. For more information on configuring GPIOs, see "General-Purpose Input/Outputs (GPIOs)" on page 750.

Table 21-1. I2C Signals (128TQFP)

Pin Name	Pin Number	Pin Mux / Pin Assignment	Pin Type	Buffer Type	Description
I2C0SCL	91	PB2 (2)	I/O	OD	I ² C module 0 clock. Note that this signal has an active pull-up. The corresponding port pin should not be configured as open drain.
I2C0SDA	92	PB3 (2)	I/O	OD	I ² C module 0 data.
I2C1SCL	49	PG0 (2)	I/O	OD	I ² C module 1 clock. Note that this signal has an active pull-up. The corresponding port pin should not be configured as open drain.
I2C1SDA	50	PG1 (2)	I/O	OD	I ² C module 1 data.
I2C2SCL	82 106 112	PL1 (2) PP5 (2) PN5 (3)	I/O	OD	I ² C module 2 clock. Note that this signal has an active pull-up. The corresponding port pin should not be configured as open drain.
I2C2SDA	81 111	PL0 (2) PN4 (3)	I/O	OD	I ² C module 2 data.
I2C3SCL	63	PK4 (2)	I/O	OD	I ² C module 3 clock. Note that this signal has an active pull-up. The corresponding port pin should not be configured as open drain.
I2C3SDA	62	PK5 (2)	I/O	OD	I ² C module 3 data.
I2C4SCL	61	PK6 (2)	I/O	OD	I ² C module 4 clock. Note that this signal has an active pull-up. The corresponding port pin should not be configured as open drain.
I2C4SDA	60	PK7 (2)	I/O	OD	I ² C module 4 data.
I2C5SCL	95 121	PB0 (2) PB4 (2)	I/O	OD	I ² C module 5 clock. Note that this signal has an active pull-up. The corresponding port pin should not be configured as open drain.
I2C5SDA	96 120	PB1 (2) PB5 (2)	I/O	OD	I ² C module 5 data.
I2C6SCL	40	PA6 (2)	I/O	OD	I ² C module 6 clock. Note that this signal has an active pull-up. The corresponding port pin should not be configured as open drain.
I2C6SDA	41	PA7 (2)	I/O	OD	I ² C module 6 data.
I2C7SCL	1 37	PD0 (2) PA4 (2)	I/O	OD	I ² C module 7 clock. Note that this signal has an active pull-up. The corresponding port pin should not be configured as open drain.
I2C7SDA	2 38	PD1 (2) PA5 (2)	I/O	OD	I ² C module 7 data.

Table 21-1. I²C Signals (128TQFP) (continued)

Pin Name	Pin Number	Pin Mux / Pin Assignment	Pin Type	Buffer Type	Description
I2C8SCL	3 35	PD2 (2) PA2 (2)	I/O	OD	I ² C module 8 clock. Note that this signal has an active pull-up. The corresponding port pin should not be configured as open drain.
I2C8SDA	4 36	PD3 (2) PA3 (2)	I/O	OD	I ² C module 8 data.
I2C9SCL	33	PA0 (2)	I/O	OD	I ² C module 9 clock. Note that this signal has an active pull-up. The corresponding port pin should not be configured as open drain.
I2C9SDA	34	PA1 (2)	I/O	OD	I ² C module 9 data.

21.3 Functional Description

Each I²C module is comprised of both master and slave functions and is identified by a unique address. A master-initiated communication generates the clock signal, SCL. For proper operation, the SDA pin must be configured as an open-drain signal. Due to the internal circuitry that supports high-speed operation, the SCL pin must not be configured as an open-drain signal, although the internal circuitry causes it to act as if it were an open drain signal. Both SDA and SCL signals must be connected to a positive supply voltage using a pull-up resistor. A typical I²C bus configuration is shown in Figure 21-2. Refer to the *I²C-bus specification and user manual* to determine the size of the pull-ups needed for proper operation.

See “Inter-Integrated Circuit (I²C) Interface” on page 1994 for I²C timing diagrams.

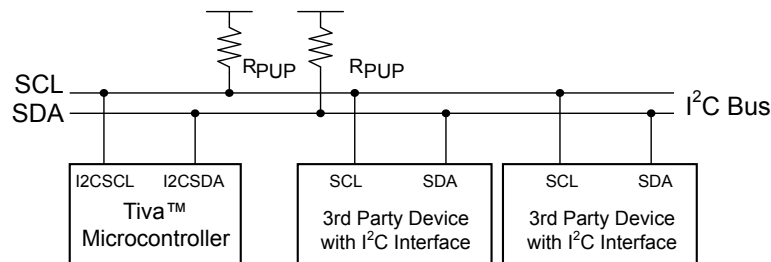
Figure 21-2. I²C Bus Configuration

21.3.1 I²C Bus Functional Overview

The I²C bus uses only two signals: SDA and SCL, named I2CSDA and I2CSCL on TM4C129ENC PDT microcontrollers. SDA is the bi-directional serial data line and SCL is the bi-directional serial clock line. The bus is considered idle when both lines are High.

Every transaction on the I²C bus is nine bits long, consisting of eight data bits and a single acknowledge bit. The number of bytes per transfer (defined as the time between a valid START and STOP condition, described in “START and STOP Conditions” on page 1403) is unrestricted, but each data byte has to be followed by an acknowledge bit, and data must be transferred MSB first. When a receiver cannot receive another complete byte, it can hold the clock line SCL Low and force the transmitter into a wait state. The data transfer continues when the receiver releases the clock SCL.

21.3.1.1 START and STOP Conditions

The protocol of the I²C bus defines two states to begin and end a transaction: START and STOP. A High-to-Low transition on the SDA line while the SCL is High is defined as a START condition, and a Low-to-High transition on the SDA line while SCL is High is defined as a STOP condition. The bus is considered busy after a START condition and free after a STOP condition. See Figure 21-3.

Figure 21-3. START and STOP Conditions



The STOP bit determines if the cycle stops at the end of the data cycle or continues on to a repeated START condition. To generate a single transmit cycle, the **I²C Master Slave Address (I2CMSA)** register is written with the desired address, the R/S bit is cleared, and the Control register is written with ACK=X (0 or 1), STOP=1, START=1, and RUN=1 to perform the operation and stop. When the operation is completed (or aborted due to an error), the interrupt pin becomes active and the data may be read from the **I²C Master Data (I2CMDR)** register. When the I²C module operates in Master receiver mode, the ACK bit is normally set causing the I²C bus controller to transmit an acknowledge automatically after each byte. This bit must be cleared when the I²C bus controller requires no further data to be transmitted from the slave transmitter.

When operating in slave mode, the STARTRIS and STOPRIS bits in the **I²C Slave Raw Interrupt Status (I2CSRIS)** register indicate detection of start and stop conditions on the bus and the **I²C Slave Masked Interrupt Status (I2CSMIS)** register can be configured to allow STARTRIS and STOPRIS to be promoted to controller interrupts (when interrupts are enabled).

21.3.1.2 Data Format with 7-Bit Address

Data transfers follow the format shown in Figure 21-4. After the START condition, a slave address is transmitted. This address is 7-bits long followed by an eighth bit, which is a data direction bit (R/S bit in the I2CMSA register). If the R/S bit is clear, it indicates a transmit operation (send), and if it is set, it indicates a request for data (receive). A data transfer is always terminated by a STOP condition generated by the master, however, a master can initiate communications with another device on the bus by generating a repeated START condition and addressing another slave without first generating a STOP condition. Various combinations of receive/transmit formats are then possible within a single transfer.

Figure 21-4. Complete Data Transfer with a 7-Bit Address

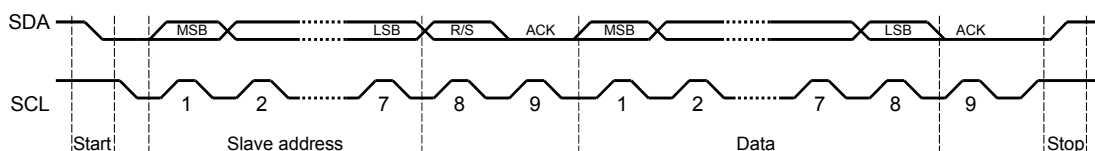

The first seven bits of the first byte make up the slave address (see Figure 21-5). The eighth bit determines the direction of the message. A zero in the R/S position of the first byte means that the

master transmits (sends) data to the selected slave, and a one in this position means that the master receives data from the slave.

Figure 21-5. R/S Bit in First Byte

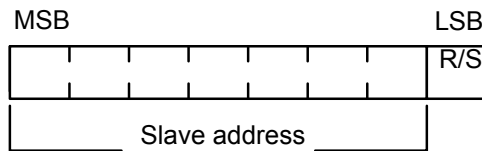

21.3.1.3 Data Validity

The data on the SDA line must be stable during the high period of the clock, and the data line can only change when SCL is Low (see Figure 21-6).

Figure 21-6. Data Validity During Bit Transfer on the I²C Bus

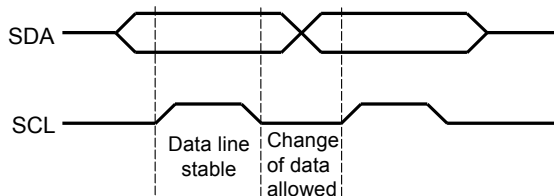

21.3.1.4 Acknowledge

All bus transactions have a required acknowledge clock cycle that is generated by the master. During the acknowledge cycle, the transmitter (which can be the master or slave) releases the SDA line. To acknowledge the transaction, the receiver must pull down SDA during the acknowledge clock cycle. The data transmitted out by the receiver during the acknowledge cycle must comply with the data validity requirements described in “Data Validity” on page 1404.

When a slave receiver does not acknowledge the slave address, SDA must be left High by the slave so that the master can generate a STOP condition and abort the current transfer. If the master device is acting as a receiver during a transfer, it is responsible for acknowledging each transfer made by the slave. Because the master controls the number of bytes in the transfer, it signals the end of data to the slave transmitter by not generating an acknowledge on the last data byte. The slave transmitter must then release SDA to allow the master to generate the STOP or a repeated START condition.

If the slave is required to provide a manual ACK or NACK, the **I²C Slave ACK Control (I2CSACKCTL)** register allows the slave to NACK for invalid data or command or ACK for valid data or command. When this operation is enabled, the MCU slave module I²C clock is pulled low after the last data bit until this register is written with the indicated response.

21.3.1.5 Repeated Start

The I²C master module has the capability of executing a repeated START (transmit or receive) after an initial transfer has occurred.

A repeated start sequence for a Master transmit is as follows:

1. When the device is in the idle state, the Master writes the slave address to the **I2CMSA** register and configures the R/S bit for the desired transfer type.

2. Data is written to the **I2CMDR** register.
3. When the **BUSY** bit in the **I2CMCS** register is 0 , the Master writes 0x3 to the **I2CMCS** register to initiate a transfer.
4. The Master does not generate a STOP condition but instead writes another slave address to the **I2CMSA** register and then writes 0x3 to initiate the repeated START.

A repeated start sequence for a Master receive is similar:

1. When the device is in idle, the Master writes the slave address to the **I2CMSA** register and configures the **R/S** bit for the desired transfer type.
2. The master reads data from the **I2CMDR** register.
3. When the **BUSY** bit in the **I2CMCS** register is 0 , the Master writes 0x3 to the **I2CMCS** register to initiate a transfer.
4. The Master does not generate a STOP condition but instead writes another slave address to the **I2CMSA** register and then writes 0x3 to initiate the repeated START.

For more information on repeated START, refer to Figure 21-12 on page 1418 and Figure 21-13 on page 1419.

21.3.1.6 Clock Low Timeout (CLTO)

The I²C slave can extend the transaction by pulling the clock low periodically to create a slow bit transfer rate. The I²C module has a 12-bit programmable counter that is used to track how long the clock has been held low. The upper 8 bits of the count value are software programmable through the **I²C Master Clock Low Timeout Count (I2CMCLKOCNT)** register. The lower four bits are not user visible and are 0x0. The **CNTL** value programmed in the **I2CMCLKOCNT** register has to be greater than 0x01. The application can program the eight most significant bits of the counter to reflect the acceptable cumulative low period in transaction. The count is loaded at the START condition and counts down on each falling edge of the internal bus clock of the Master. Note that the internal bus clock generated for this counter keeps running at the programmed I²C speed even if SCL is held low on the bus. Upon reaching terminal count, the master state machine forces ABORT on the bus by issuing a STOP condition at the instance of SCL and SDA release.

As an example, if an I²C module was operating at 100 kHz speed, programming the **I2CMCLKOCNT** register to 0xDA would translate to the value 0xDA0 since the lower four bits are set to 0x0. This would translate to a decimal value of 3488 clocks or a cumulative clock low period of 34.88 ms at 100 kHz.

The **CLKRIS** bit in the **I²C Master Raw Interrupt Status (I2CMRIS)** register is set when the clock timeout period is reached, allowing the master to start corrective action to resolve the remote slave state. In addition, the **CLKTO** bit in the **I²C Master Control/Status (I2CMCS)** register is set; this bit is cleared when a STOP condition is sent or during the I²C master reset. The status of the raw SDA and SCL signals are readable by software through the **SDA** and **SCL** bits in the **I²C Master Bus Monitor (I2CMBMON)** register to help determine the state of the remote slave.

In the event of a CLTO condition, application software must choose how it intends to attempt bus recovery. Most applications may attempt to manually toggle the I²C pins to force the slave to let go of the clock signal (a common solution is to attempt to force a STOP on the bus). If a CLTO is detected before the end of a burst transfer, and the bus is successfully recovered by the master, the master hardware attempts to finish the pending burst operation. Depending on the state of the

slave after bus recovery, the actual behavior on the bus varies. If the slave resumes in a state where it can acknowledge the master (essentially, where it was before the bus hang), it continues where it left off. However, if the slave resumes in a reset state (or if a forced STOP by the master causes the slave to enter the idle state), it may ignore the master's attempt to complete the burst operation and NAK the first data byte that the master sends or requests.

Since the behavior of slaves cannot always be predicted, it is suggested that the application software always write the STOP bit in the **I²C Master Configuration (I2CMCR)** register during the CLTO interrupt service routine. This limits the amount of data the master attempts to send or receive upon bus recovery to a single byte, and after the single byte is on the wire, the master issues a STOP. An alternative solution is to have the application software reset the I²C peripheral before attempting to manually recover the bus. This solution allows the I²C master hardware to be returned to a known good (and idle) state before attempting to recover a stuck bus and prevents any unwanted data from appearing on the wire.

Note: The Master Clock Low Timeout counter counts for the entire time SCL is held Low continuously. If SCL is deasserted at any point, the Master Clock Low Timeout Counter is reloaded with the value in the **I2CMCLKOCNT** register and begins counting down from this value.

21.3.1.7 Dual Address

The I²C interface supports dual address capability for the slave. The additional programmable address is provided and can be matched if enabled. In legacy mode with dual address disabled, the I²C slave provides an ACK on the bus if the address matches the OAR field in the **I2CSOAR** register. In dual address mode, the I²C slave provides an ACK on the bus if either the OAR field in the **I2CSOAR** register or the OAR2 field in the **I2CSOAR2** register is matched. The enable for dual address is programmable through the OAR2EN bit in the **I2CSOAR2** register and there is no disable on the legacy address.

The OAR2SEL bit in the **I2CSCSR** register indicates if the address that was ACKed is the alternate address or not. When this bit is clear, it indicates either legacy operation or no address match.

21.3.1.8 Arbitration

A master may start a transfer only if the bus is idle. It's possible for two or more masters to generate a START condition within minimum hold time of the START condition. In these situations, an arbitration scheme takes place on the SDA line, while SCL is High. During arbitration, the first of the competing master devices to place a 1 (High) on SDA, while another master transmits a 0 (Low), switches off its data output stage and retires until the bus is idle again.

Arbitration can take place over several bits. Its first stage is a comparison of address bits, and if both masters are trying to address the same device, arbitration continues on to the comparison of data bits.

If arbitration is lost when the I2C master is initiating a BURST with the TX FIFO enabled, the application should execute the following steps to correctly handle the arbitration loss:

1. Flush and disable the TX FIFO
2. Clear and mask the TXFE interrupt by clearing the TXFEIM bit in the **I2CMIMR** register.

Once the bus is IDLE, the TXFIFO can be filled and enabled, the TXFE bit can be unmasked and a new BURST transaction can be initiated.

21.3.1.9 Glitch Suppression in Multi-Master Configuration

When a multi-master configuration is being used, the `PULSESEL` bit in the `I2CMTPR` register can be programmed to provide glitch suppression on the SCL and SDA lines and assure proper signal values. The glitch suppression value is in terms of buffered system clocks. Note that all signals will be delayed internally when glitch suppression is nonzero. For example, if `PULSESEL` is set to 0x7, 31 clocks should be added onto the calculation for the expected transaction time.

21.3.1.10 SMBus Operation

The SMBus interface is based on the I²C protocol; however, some differences exist between the two. These differences must be handled through software in order to make sure the SMBus protocol, including timing specifications, is met. Note that the SMBus 2.0 specification limits the maximum frequency of the interface to 100 KHz, as a result, I²C Standard speed operation is used for SMBus.

The SMBus/ I²C slave can extend the transaction if it is not ready by pulling the clock low. The SMBus specification allows the maximum timeout for such elongated transaction to be between 25 to 35 ms. The I²C specification does not have this requirement. The I²C module supports a programmable count to support clock-low timeout for the master to error out and take appropriate action as required. This feature is explained in “Clock Low Timeout (CLTO)” on page 1405. Note that if transactions are extended, a timeout period should be programmed in the `I2CMCLKOCNT` register, and the `CLKRIS` bit in the `I2CMRIS` register should not be masked.

Unlike the I²C slave, the SMBus slave must respond with an ACK response to its address regardless of whether it is ready or not. As a result, the I²C slave sends an ACK response to its address and a NACK response on the data byte if it is not ready. The `ARBLST` bit in the `I2CMCS` register is set if there were any issues with the transfer. In addition, the slave can send a NACK at any time to force the master to stop sending additional bytes.

The I²C Interface supports μ DMA for efficient data handling. The μ DMA operation needs FIFOs to be enabled for appropriate transfer type to perform I²C Master for burst transfers and all types of Slave transfers. The I²C interface is supported by two channels, one for Rx (I²C to Memory) and one for Tx (Memory to I²C) transfers.. See “FIFO and μ DMA Operation” on page 1411 for more information.

Quick Command

Quick Command is a simple, compact SMBus protocol that sends an address and 1-bit of data in the R/S bit of the I²C header byte to communicate a command to the slave, typically a “turn off” or “turn on”. The I²C master peripheral has the ability to send a Quick Command by writing the target address and R/S value into the `I2CMSA` register followed by a write to `I2CMCS` with a value of 0x27. SMBus requires the slave to be able to accept and process commands and the master to generate the Quick Command transactions. The master also has the capability to stop the transaction after acknowledgement from a slave.

The I²C slave peripheral requires special handling when a Quick Command is sent. In the case where a master sends a Quick Command with the R/S (data) bit cleared, the `QCMDST` bit in `I2CSCSR` is set, and the `QCMDRW` bit shows the data value (which in this case is 0) when the `STOPRIS` bit is set in `I2CSRIS` and the STOP interrupt is asserted. In this scenario, a `DATARIS` interrupt bit is not set. When the master sends a Quick Command with the R/S (data) bit set, the `DATARIS` bit is set to notify the slave to write a data byte to `I2CSDR` in which bit 7 is set. A “dummy write” of 0xFF to the `I2CSDR` register is recommended. After the write to `I2CSDR`, the STOP interrupt is asserted and the `QCMDST` and `QCMDRW` bits are set in the `I2CSCSR` register to indicate that a quick command read occurred and the last transaction was a Quick Command. Therefore, when the slave must

receive a Quick Command, it should be expecting such a command because it must write the **I2CSDR** with a specific value when R/S is set.

21.3.2 Available Speed Modes

The I²C bus can run in Standard mode (100 kbps), Fast mode (400 kbps), Fast mode plus (1 Mbps) or High-Speed mode (3.4 Mbps, provided correct system clock frequency is set and there is appropriate pull strength on SCL and SDA lines). The selected mode should match the speed of the other I²C devices on the bus.

21.3.2.1 Standard, Fast, and Fast Plus Modes

Standard, Fast, and Fast Plus modes are selected using a value in the **I²C Master Timer Period (I2CMTPR)** register that results in an SCL frequency of 100 kbps for Standard mode, 400 kbps for Fast mode, or 1 Mbps for Fast mode plus.

The I²C clock rate is determined by the parameters *CLK_PRD*, *TIMER_PRD*, *SCL_LP*, and *SCL_HP* where:

CLK_PRD is the system clock period

SCL_LP is the low phase of SCL (fixed at 6)

SCL_HP is the high phase of SCL (fixed at 4)

TIMER_PRD is the programmed value in the **I2CMTPR** register (see page 1437). This value is determined by replacing the known variables in the equation below and solving for *TIMER_PRD*.

The I²C clock period is calculated as follows:

$$SCL_PERIOD = 2 \times (1 + TIMER_PRD) \times (SCL_LP + SCL_HP) \times CLK_PRD$$

For example:

$$CLK_PRD = 50 \text{ ns}$$

$$TIMER_PRD = 2$$

$$SCL_LP = 6$$

$$SCL_HP = 4$$

yields a SCL frequency of:

$$1/SCL_PERIOD = 333 \text{ Khz}$$

Table 21-2 gives examples of the timer periods that should be used to generate Standard, Fast mode, and Fast mode plus SCL frequencies based on various system clock frequencies.

Table 21-2. Examples of I²C Master Timer Period Versus Speed Mode

System Clock	Timer Period	Standard Mode	Timer Period	Fast Mode	Timer Period	Fast Mode Plus
4 MHz	0x01	100 Kbps	-	-	-	-
6 MHz	0x02	100 Kbps	-	-	-	-
12.5 MHz	0x06	89 Kbps	0x01	312 Kbps	-	-
16.7 MHz	0x08	93 Kbps	0x02	278 Kbps	-	-
20 MHz	0x09	100 Kbps	0x02	333 Kbps	-	-
25 MHz	0x0C	96.2 Kbps	0x03	312 Kbps	-	-
33 MHz	0x10	97.1 Kbps	0x04	330 Kbps	-	-

Table 21-2. Examples of I²C Master Timer Period Versus Speed Mode (continued)

System Clock	Timer Period	Standard Mode	Timer Period	Fast Mode	Timer Period	Fast Mode Plus
40 MHz	0x13	100 Kbps	0x04	400 Kbps	0x01	1000 Kbps
50 MHz	0x18	100 Kbps	0x06	357 Kbps	0x02	833 Kbps
80 MHz	0x27	100 Kbps	0x09	400 Kbps	0x03	1000 Kbps
100 MHz	0x31	100 Kbps	0x0C	385 Kbps	0x04	1000 Kbps
120 MHz	0x3B	100 Kbps	0xE	400 Kbps	0x5	1000 Kbps

21.3.2.2 High-Speed Mode

The TM4C129ENCPDT I²C peripheral has support for High-speed operation as both a master and slave. High-Speed mode is configured by setting the HS bit in the **I²C Master Control/Status (I2CMCS)** register. High-Speed mode transmits data at a high bit rate with a 66.6%/33.3% duty cycle, but communication and arbitration are done at Standard, Fast mode, or Fast-mode plus speed, depending on which is selected by the user. When the HS bit in the **I2CMCS** register is set, current mode pull-ups are enabled.

The clock period can be selected using the equation below, but in this case, SCL_LP=2 and SCL_HP=1.

$$SCL_PERIOD = 2 \times (1 + TIMER_PRD) \times (SCL_LP + SCL_HP) \times CLK_PRD$$

So for example:

$$CLK_PRD = 25 \text{ ns}$$

$$TIMER_PRD = 1$$

$$SCL_LP=2$$

$$SCL_HP=1$$

yields a SCL frequency of:

$$1/T = 3.33 \text{ Mhz}$$

Table 21-3 on page 1409 gives examples of timer period and system clock in High-Speed mode. Note that the HS bit in the **I2CMTPR** register needs to be set for the TPR value to be used in High-Speed mode.

Table 21-3. Examples of I²C Master Timer Period in High-Speed Mode

System Clock	Timer Period	Transmission Mode
40 MHz	0x01	3.33 Mbps
50 MHz	0x02	2.77 Mbps
80 MHz	0x03	3.33 Mbps

When operating as a master, the protocol is shown in Figure 21-7. The master is responsible for sending a master code byte in either Standard (100 Kbps) or Fast-mode (400 Kbps) before it begins transferring in High-speed mode. The master code byte must contain data in the form of 0000.1XXX and is used to tell the slave devices to prepare for a High-speed transfer. The master code byte should never be acknowledged by a slave since it is only used to indicate that the upcoming data is going to be transferred at a higher data rate. To send the master code byte for a standard high-speed transfer, software should place the value of the master code byte into the **I2CMSA** register and write the **I2CMCS** register with a value of 0x13. If a high-speed burst transfer is required,

then to send the master code byte, software should place the value of the master code byte into the **I2CMSA** register and write the **I2CMCS** register with 0x50. Either configuration places the I²C master peripheral in High-speed mode, and all subsequent transfers (until STOP) are carried out at High-speed data rate using the normal **I2CMCS** command bits, without setting the HS bit in the **I2CMCS** register. Again, setting the HS bit in the **I2CMCS** register is only necessary during the master code byte.

When operating as a High-speed slave, there is no additional software required.

Figure 21-7. High-Speed Data Format

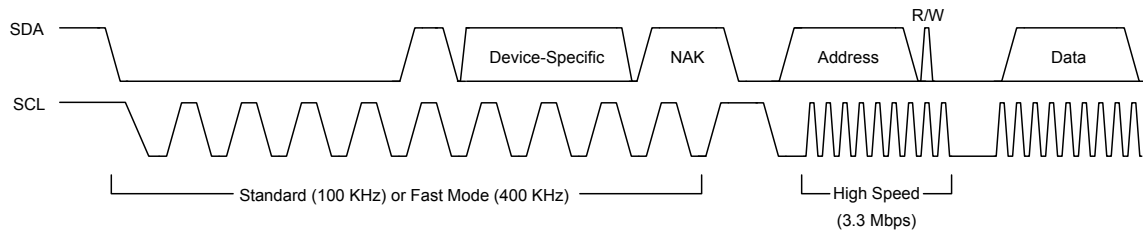

Note: High-Speed mode is 3.4 Mbps, provided correct system clock frequency is set and there is appropriate pull strength on SCL and SDA lines.

21.3.3 Interrupts

The I²C can generate interrupts when the following conditions are observed in the Master Module:

- Master transaction completed (RIS bit)
- Master arbitration lost (ARBLOSTRIS bit)
- Master Address/Data NACK (NACKRIS bit)
- Master bus timeout (CLKRIS bit)
- Next byte request (RIS bit)
- Stop condition on bus detected (STOPRIS bit)
- Start condition on bus detected (STARTRIS bit)
- RX DMA interrupt pending (DMARXRIS bit)
- TX DMA interrupt pending (DMATXRIS bit)
- Trigger value for FIFO has been reached and a TX FIFO request interrupt is pending (TXRIS bit)
- Trigger value for FIFO has been reached and a RX FIFO request interrupt is pending (RXRIS bit)
- Transmit FIFO is empty (TXFERIS bit)
- Receive FIFO is full (RXFFRIS bit)

Interrupts are generated when the following conditions are observed in the Slave Module:

- Slave transaction received (DATARIS bit)
- Slave transaction requested (DATARIS bit)
- Slave next byte transfer request (DATARIS bit)
- Stop condition on bus detected (STOPRIS bit)
- Start condition on bus detected (STARTRIS bit)
- RX DMA interrupt pending (DMARXRIS bit)
- TX DMA interrupt pending (DMATXRIS bit)
- Programmable trigger value for FIFO has been reached and a TX FIFO request interrupt is pending (TXRIS bit)
- Programmable trigger value for FIFO has been reached and a RX FIFO request interrupt is pending (RXRIS bit)
- Transmit FIFO is empty (TXFERIS bit)
- Receive FIFO is full (RXFFRIS bit)

The I²C master and I²C slave modules have separate interrupt registers. Interrupts can be masked by clearing the appropriate bit in the **I2CMIMR** or **I2CSIMR** register. Note that the RIS bit in the **Master Raw Interrupt Status (I2CMRIS)** register and the DATARIS bit in the **Slave Raw Interrupt Status (I2CSRIS)** register have multiple interrupt causes including a next byte transfer request interrupt. This interrupt is generated when both master and slave are requesting a receive or transmit transaction.

21.3.4 Loopback Operation

The I²C modules can be placed into an internal loopback mode for diagnostic or debug work by setting the LPBK bit in the **I²C Master Configuration (I2CMCR)** register. In loopback mode, the SDA and SCL signals from the master and are tied to the SDA and SCL signals of the slave module to allow internal testing of the device without having to go through I/O.

21.3.5 FIFO and μ DMA Operation

Both the master and the slave module have the capability to access two 8-byte FIFOs that can be used in conjunction with the μ DMA for fast transfer of data. The transmit (TX) FIFO and receive (RX) FIFO can be independently assigned to either the I²C master or I²C slave. Thus, the following FIFO assignments are allowed:

- The transmit and receive FIFOs can be assigned to the master
- The transmit and receive FIFOs can be assigned to the slave
- The transmit FIFO can be assigned to the master, while the receive FIFO is assigned to the slave and vice versa.

In most cases, both FIFOs will be assigned to either the master or the slave. The FIFO assignment is configured by programming the TXASGNMT and RXASGNMT bit in the **I²C FIFO Control (I2CFIFOCTL)** register.

Each FIFO has a programmable threshold point which indicates when the FIFO service interrupt should be generated. Additionally, a FIFO receive full and transmit empty interrupt can be enabled in the Interrupt Mask (**I2CxIMR**) registers of both the master and slave. Note that if we clear the **TXFERIS** interrupt (by setting the **TXFEIC** bit) when the TX FIFO is empty, the **TXFERIS** interrupt does not reassert even though the TX FIFO remains empty in this situation.

When a FIFO is not assigned to a master or a slave module, the FIFO interrupt and status signals to the module are forced to a state that indicates the FIFO is empty. For example, if the TX FIFO is assigned to the master module, the status signals to the slave transmit interface indicates that the FIFO is empty.

Note: The FIFOs must be empty when reassigning the FIFOs for proper functionality

21.3.5.1 Master Module Burst Mode

A BURST command is provided for the master module which allows a sequence of data transfers using the μ DMA (or software, if desired) to handle the data in the FIFO. The BURST command is enabled by setting the BURST bit in the **Master Control/Status (I2CMCS)** register. The number of bytes transferred by a BURST request is programmed in the **I2C Master Burst Length (I2CMLEN)** register and a copy of this value is automatically written to the **I2C Master Burst Count (I2CMBCNT)** register to be used as a down-counter during the BURST transfer. The bytes written to the **I2C FIFO Data (I2CFIFODATA)** register are transferred to the RX FIFO or TX FIFO depending on whether a transmit or receive is being executed. If data is NACKed during a BURST and the **STOP** bit is set in the **I2CMCS** register, the transfer terminates. If the **STOP** bit is not set, the software application must issue a repeated **STOP** or **START** when a NACK interrupt is asserted. In the case of a NACK, the **I2CMBCNT** register can be used to determine the amount of data that was transferred prior to the BURST termination. If the Address is NACKed during a transfer, then a **STOP** is issued.

Master Module μ DMA Functionality

When the **Master Control/Status (I2CMCS)** register is set to enable BURST and the master I²C μ DMA channel is enabled in the **DMA Channel Map Select n (DMACHMAPn)** registers in the μ DMA, the master control module will assert either the internal single μ DMA request signal (**dma_sreq**) or multiple μ DMA request signal (**dma_req**) to the μ DMA. Note that there are separate **dma_req** and **dma_sreq** signals for transmit and receive. A single μ DMA request (**dma_sreq**) will be asserted by the Master module when the Rx FIFO has at least one data byte present in the FIFO and/or when the Tx FIFO has at least one space available to fill. The **dma_req** (or Burst) signal will be asserted when Rx FIFO fill level is higher than trigger level and/or the Tx FIFO burst length remaining is less than 4 bytes and the FIFO fill level is less than trigger level. If a single transfer or BURST operation has completed, the μ DMA sends a **dma_done** signal to the master module represented by the **DMATX/DMARX** interrupts in the **I2CMIMR/I2CMRIS/I2CMMIS/I2CMICR** registers.

If the μ DMA I²C channel is disabled and software is used to handle the BURST command, software can read the **FIFO Status (I2CFIFOSTAT)** Register and the **Master Burst Count (I2CMBC)** register to determine whether the FIFO needs servicing during the BURST transaction. A trigger value can be programmed in the **I2CFIFOCTL** register to allow for interrupts at various fill levels of the FIFOs.

The **NACK** and **ARBLOST** bits in the interrupt status registers can be enabled to indicate no acknowledgement of data transfer or an arbitration loss on the bus.

When the Master module is transmitting FIFO data, software can fill the Tx FIFO in advance of setting the BURST bit in the **I2CMCS** register. If the FIFO is empty when the μ DMA is enabled for BURST mode, the **dma_req** and **dma_sreq** both assert (assuming the **I2CMLEN** register is programmed to at least 4 bytes and the Tx FIFO fill level is less than the trigger set). If the **I2CMLEN** register value is less than 4 and the Tx FIFO is not full but more than trigger level, only **dma_sreq** will assert. Single requests will be generated as required to keep the FIFO full until the number of

bytes specified in the **I2CMBLEN** register has been transferred to the FIFO (and the **I2CMBCOUNT** register reaches 0x0). At this point, no further requests are generated until the next BURST command is issued. If the μ DMA is disabled, FIFOs will be serviced based on the interrupts active in the Master interrupt status registers, the FIFO trigger values shown in the **I2CFIFOSTATUS** register and completion of a BURST transfer.

When the Master module is receiving FIFO data, the Rx FIFO is initially empty and no requests are asserted. If data is read from the slave and placed into the Rx FIFO, the `dma_sreq` signal to the μ DMA is asserted to indicate there is data to be transferred. If the Rx FIFO contains at least 4 bytes, the `dma_req` signal is also asserted. The μ DMA will continue to transfer data out of the Rx FIFO until it has reached the amount of bytes programmed in the **I2CMBLEN** register.

Note: The **TXFEIM** interrupt mask bit in the **I2CMIMR** register should be clear (masking the **TXFE** interrupt) when the master is performing an RX Burst from the RXFIFO and should be unmasked before starting a TX FIFO transfers.

21.3.5.2 Slave Module

The slave module also has the capability to use the μ DMA in Rx and Tx FIFO data transfers. If the Tx FIFO is assigned to the slave module and the **TXFIFO** bit is set in the **I2CSCSR** register, the slave module will generate a single μ DMA request, `dma_sreq`, if the master module requests the next byte transfer. If the FIFO fill level is less than the trigger level, a μ DMA multiple transfer request, `dma_req`, will be asserted to continue data transfers from the μ DMA.

If the Rx FIFO is assigned to the slave module and the **RXFIFO** bit is set in the **I2CSCSR** register, then the slave module will generate a signal μ DMA request, `dma_sreq`, if there is any data to be transferred. The `dma_req` signal will be asserted when the Rx FIFO has more data than the trigger level programmed by the **RXTRIG** bit in the **I2CFIFOCTL** register.

Note: Best practice recommends that an application should not switch between the **I2CSDR** register and TX FIFO or vice versa for successive transactions.

21.3.6 Command Sequence Flow Charts

This section details the steps required to perform the various I²C transfer types in both master and slave mode. Refer to Table 21-5 on page 1432 for further sequence information.

21.3.6.1 I²C Master Command Sequences

The figures that follow show the command sequences available for the I²C master.

Figure 21-8. Master Single TRANSMIT

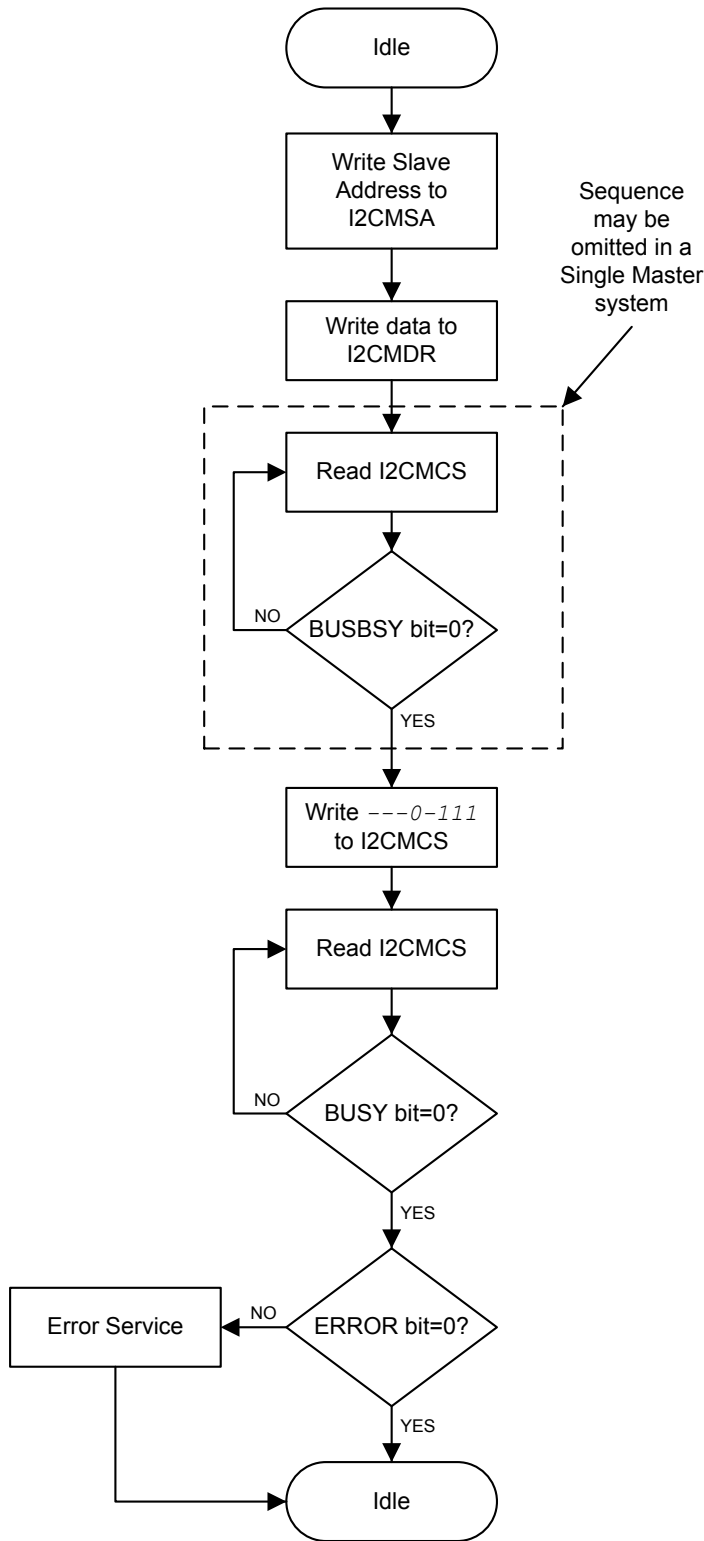

Figure 21-9. Master Single RECEIVE

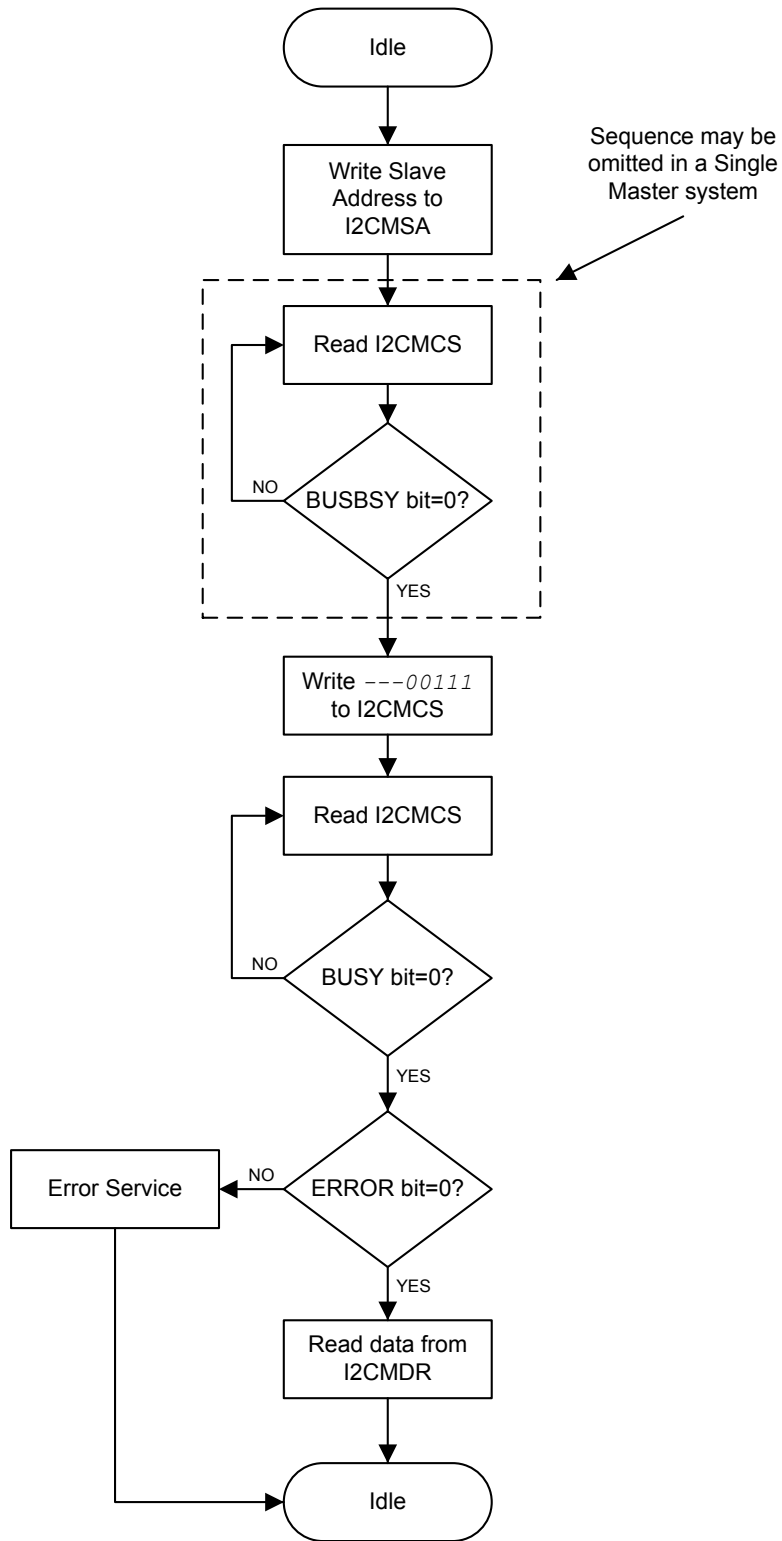

Figure 21-10. Master TRANSMIT of Multiple Data Bytes



Figure 21-11. Master RECEIVE of Multiple Data Bytes

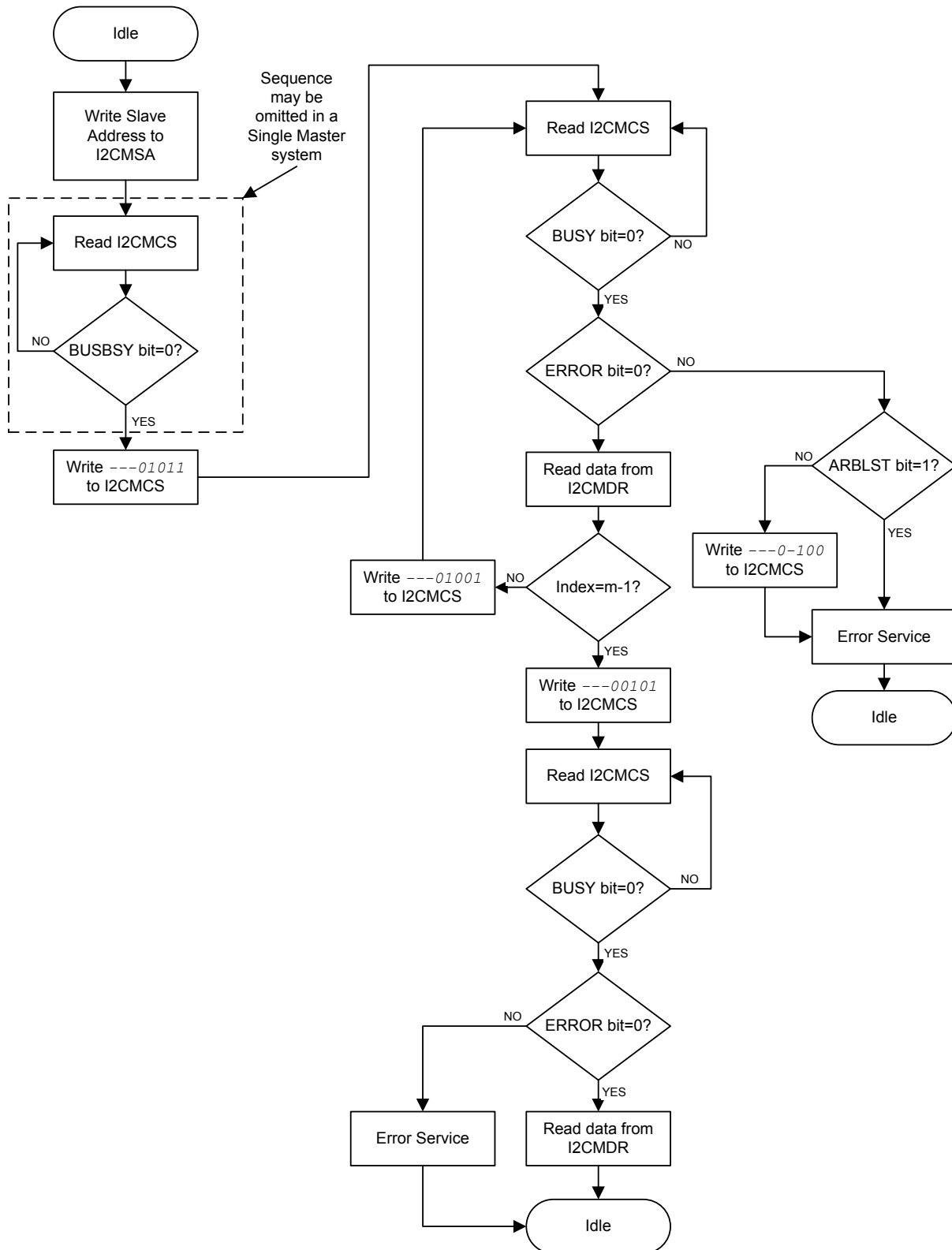

Figure 21-12. Master RECEIVE with Repeated START after Master TRANSMIT



Figure 21-13. Master TRANSMIT with Repeated START after Master RECEIVE



Figure 21-14. Standard High Speed Mode Master Transmit

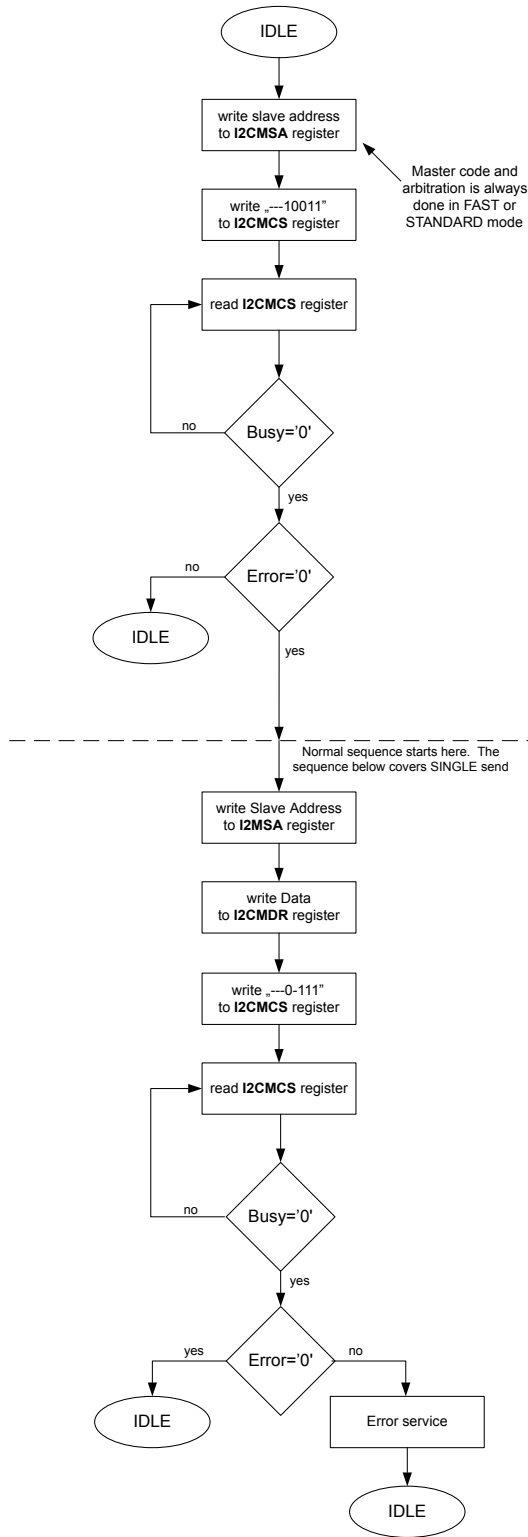

21.3.6.2 I²C Slave Command Sequences

Figure 21-15 on page 1421 presents the command sequence available for the I²C slave.

Figure 21-15. Slave Command Sequence

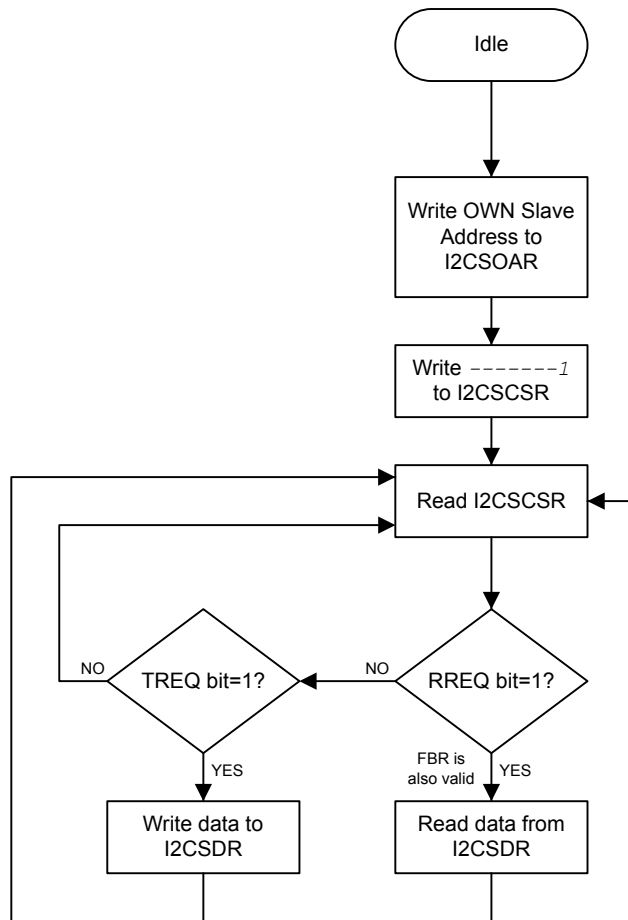

21.4 Initialization and Configuration

21.4.1 Configure the I²C Module to Transmit a Single Byte as a Master

The following example shows how to configure the I²C module to transmit a single byte as a master. This assumes the system clock is 20 MHz.

1. Enable the I²C clock using the **RCGCI2C** register in the System Control module (see page 398).
2. Enable the clock to the appropriate GPIO module via the **RCGCGPIO** register in the System Control module (see page 389). To find out which GPIO port to enable, refer to Table 29-5 on page 1932.
3. In the GPIO module, enable the appropriate pins for their alternate function using the **GPIOAFSEL** register (see page 778). To determine which GPIOs to configure, see Table 29-4 on page 1921.

4. Enable the I²CSDA pin for open-drain operation. See page 783.
5. Configure the PMCN fields in the GPIOCTL register to assign the I²C signals to the appropriate pins. See page 795 and Table 29-5 on page 1932.
6. Initialize the I²C Master by writing the I2CMCR register with a value of 0x0000.0010.
7. Set the desired SCL clock speed of 100 Kbps by writing the I2CMTPR register with the correct value. The value written to the I2CMTPR register represents the number of system clock periods in one SCL clock period. The TPR value is determined by the following equation:

$$\begin{aligned} \text{TPR} &= (\text{System Clock} / (2 * (\text{SCL_LP} + \text{SCL_HP}) * \text{SCL_CLK})) - 1; \\ \text{TPR} &= (20\text{MHz} / (2 * (6+4) * 100000)) - 1; \\ \text{TPR} &= 9 \end{aligned}$$

Write the I2CMTPR register with the value of 0x0000.0009.

8. Specify the slave address of the master and that the next operation is a Transmit by writing the I2CMSA register with a value of 0x0000.0076. This sets the slave address to 0x3B.
9. Place data (byte) to be transmitted in the data register by writing the I2CMDR register with the desired data.
10. Initiate a single byte transmit of the data from Master to Slave by writing the I2CMCS register with a value of 0x0000.0007 (STOP, START, RUN).
11. Wait until the transmission completes by polling the I2CMCS register's BUSBSY bit until it has been cleared.
12. Check the ERROR bit in the I2CMCS register to confirm the transmit was acknowledged.

21.4.2 Configure the I²C Master to High Speed Mode

To configure the I²C master to High Speed mode:

1. Enable the I²C clock using the RCGCI2C register in the System Control module (see page 398).
2. Enable the clock to the appropriate GPIO module via the RCGCGPIO register in the System Control module (see page 389). To find out which GPIO port to enable, refer to Table 29-5 on page 1932.
3. In the GPIO module, enable the appropriate pins for their alternate function using the GPIOAFSEL register (see page 778). To determine which GPIOs to configure, see Table 29-4 on page 1921.
4. Enable the I²CSDA pin for open-drain operation. See page 783.
5. Configure the PMCN fields in the GPIOCTL register to assign the I²C signals to the appropriate pins. See page 795 and Table 29-5 on page 1932.
6. Initialize the I²C Master by writing the I2CMCR register with a value of 0x0000.0010.
7. Set the desired SCL clock speed of 3.33 Mbps by writing the I2CMTPR register with the correct value. The value written to the I2CMTPR register represents the number of system clock periods in one SCL clock period. The TPR value is determined by the following equation:

```

TPR = (System Clock / (2 * (SCL_LP + SCL_HP) * SCL_CLK)) - 1;
TPR = (80 MHz / (2 * (2 + 1) * 3330000)) - 1;
TPR = 3

```

Write the **I2CMTPR** register with the value of 0x0000.0003.

8. To send the master code byte, software should place the value of the master code byte into the I2CMSA register and write the I2CMCS register with the following value depending on the required operation:
 - For Standard High-Speed mode, the **I2CMCS** register should be written with 0x13.
 - For Burst High-Speed mode, the **I2CMCS** register should be written with 0x50.
9. This places the I2C master peripheral in High-speed mode, and all subsequent transfers (until STOP) are carried out at High-speed data rate using the normal **I2CMCS** command bits, without setting the HS bit in the **I2CMCS** register.
10. The transaction is ended by setting the STOP bit in the **I2CMCS** register.
11. Wait until the transmission completes by polling the **I2CMCS** register's BUSBSY bit until it has been cleared.
12. Check the ERROR bit in the **I2CMCS** register to confirm the transmit was acknowledged.

21.5 Register Map

Table 21-4 on page 1424 lists the I²C registers. All addresses given are relative to the I²C base address:

- I²C 0: 0x4002.0000
- I²C 1: 0x4002.1000
- I²C 2: 0x4002.2000
- I²C 3: 0x4002.3000
- I²C 4: 0x400C.0000
- I²C 5: 0x400C.1000
- I²C 6: 0x400C.2000
- I²C 7: 0x400C.3000
- I²C 8: 0x400B.8000
- I²C 9: 0x400B.9000

Note that the I²C module clock must be enabled before the registers can be programmed (see page 398). There must be a delay of 3 system clocks after the I²C module clock is enabled before any I²C module registers are accessed.

The hw_i2c.h file in the TivaWare™ Driver Library uses a base address of 0x800 for the I²C slave registers. Be aware when using registers with offsets between 0x800 and 0x818 that TivaWare™ for C Series uses an offset between 0x000 and 0x018 with the slave base address.

Table 21-4. Inter-Integrated Circuit (I²C) Interface Register Map

Offset	Name	Type	Reset	Description	See page
I²C Master					
0x000	I2CMSA	RW	0x0000.0000	I2C Master Slave Address	1426
0x004	I2CMCS	RW	0x0000.0020	I2C Master Control/Status	1427
0x008	I2CMDR	RW	0x0000.0000	I2C Master Data	1436
0x00C	I2CMTPR	RW	0x0000.0001	I2C Master Timer Period	1437
0x010	I2CMIMR	RW	0x0000.0000	I2C Master Interrupt Mask	1439
0x014	I2CMRIS	RO	0x0000.0000	I2C Master Raw Interrupt Status	1442
0x018	I2CMMIS	RO	0x0000.0000	I2C Master Masked Interrupt Status	1445
0x01C	I2CMICR	WO	0x0000.0000	I2C Master Interrupt Clear	1448
0x020	I2CMCR	RW	0x0000.0000	I2C Master Configuration	1450
0x024	I2CMCLKOCNT	RW	0x0000.0000	I2C Master Clock Low Timeout Count	1451
0x02C	I2CMBMON	RO	0x0000.0003	I2C Master Bus Monitor	1452
0x030	I2CMBLEN	RW	0x0000.0000	I2C Master Burst Length	1453
0x034	I2CMBCNT	RO	0x0000.0000	I2C Master Burst Count	1454
I²C Slave					
0x800	I2CSOAR	RW	0x0000.0000	I2C Slave Own Address	1455
0x804	I2CSCSR	RO	0x0000.0000	I2C Slave Control/Status	1456
0x808	I2CSDR	RW	0x0000.0000	I2C Slave Data	1459
0x80C	I2CSIMR	RW	0x0000.0000	I2C Slave Interrupt Mask	1460
0x810	I2CSRIS	RO	0x0000.0000	I2C Slave Raw Interrupt Status	1462
0x814	I2CSMIS	RO	0x0000.0000	I2C Slave Masked Interrupt Status	1465
0x818	I2CSICR	WO	0x0000.0000	I2C Slave Interrupt Clear	1468
0x81C	I2CSOAR2	RW	0x0000.0000	I2C Slave Own Address 2	1470
0x820	I2CSACKCTL	RW	0x0000.0000	I2C Slave ACK Control	1471
I²C Status and Control					
0xF00	I2CFIFODATA	RW	0x0000.0000	I2C FIFO Data	1472
0xF04	I2CFIFOCTL	RW	0x0004.0004	I2C FIFO Control	1474
0xF08	I2CFIFOSTATUS	RO	0x0001.0005	I2C FIFO Status	1476
0xFC0	I2CPP	RO	0x0000.0001	I2C Peripheral Properties	1478
0xFC4	I2CPC	RO	0x0000.0001	I2C Peripheral Configuration	1479

21.6 Register Descriptions (I²C Master)

The remainder of this section lists and describes the I²C master registers, in numerical order by address offset.

Register 1: I²C Master Slave Address (I2CMSA), offset 0x000

This register consists of eight bits: seven address bits (A6-A0), and a Receive/Send bit, which determines if the next operation is a Receive (High), or Transmit (Low).

I2C Master Slave Address (I2CMSA)

I2C 0 base: 0x4002.0000
 I2C 1 base: 0x4002.1000
 I2C 2 base: 0x4002.2000
 I2C 3 base: 0x4002.3000
 I2C 4 base: 0x400C.0000
 I2C 5 base: 0x400C.1000
 I2C 6 base: 0x400C.2000
 I2C 7 base: 0x400C.3000
 I2C 8 base: 0x400B.8000
 I2C 9 base: 0x400B.9000
 Offset 0x000
 Type RW, reset 0x0000.0000

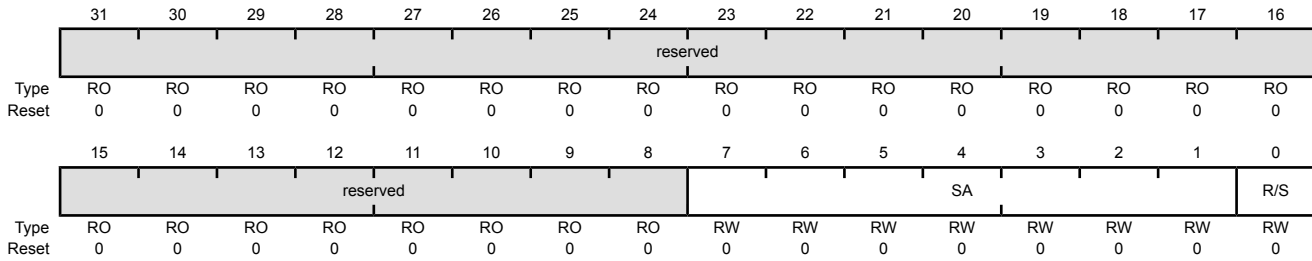

Bit/Field	Name	Type	Reset	Description
31:8	reserved	RO	0x0000.00	Software should not rely on the value of a reserved bit. To provide compatibility with future products, the value of a reserved bit should be preserved across a read-modify-write operation.
7:1	SA	RW	0x00	I ² C Slave Address This field specifies bits A6 through A0 of the slave address.
0	R/S	RW	0	Receive/Send The R/S bit specifies if the next master operation is a Receive (High) or Transmit (Low). Value Description 0 Transmit 1 Receive

Register 2: I²C Master Control/Status (I2CMCS), offset 0x004

This register accesses status bits when read and control bits when written. When read, the status register indicates the state of the I²C bus controller. When written, the control register configures the I²C controller operation.

The **START** bit generates the **START** or **REPEATED START** condition. The **STOP** bit determines if the cycle stops at the end of the data cycle or continues to the next transfer cycle, which could be a repeated **START**. To generate a single transmit cycle, the **I²C Master Slave Address (I2CMSA)** register is written with the desired address, the **R/S** bit is cleared, and this register is written with **ACK=X** (0 or 1), **STOP=1**, **START=1**, and **RUN=1** to perform the operation and stop. When the operation is completed (or aborted due an error), an interrupt becomes active and the data may be read from the **I2CMDR** register. When the I²C module operates in Master receiver mode, the **ACK** bit is normally set, causing the I²C bus controller to transmit an acknowledge automatically after each byte. This bit must be cleared when the I²C bus controller requires no further data to be transmitted from the slave transmitter.

Read-Only Status Register

I2C Master Control/Status (I2CMCS)

I2C 0 base: 0x4002.0000

I2C 1 base: 0x4002.1000

I2C 2 base: 0x4002.2000

I2C 3 base: 0x4002.3000

I2C 4 base: 0x400C.0000

I2C 5 base: 0x400C.1000

I2C 6 base: 0x400C.2000

I2C 7 base: 0x400C.3000

I2C 8 base: 0x400B.8000

I2C 9 base: 0x400B.9000

Offset 0x004

Type RO, reset 0x0000.0020

	31	30	29	28	27	26	25	24	23	22	21	20	19	18	17	16	
	ACTDMARX	ACTDMATX	reserved														
Type	RO	RO	RO	RO	RO	RO	RO	RO	RO	RO	RO	RO	RO	RO	RO	RO	
Reset	0	0	0	0	0	0	0	0	0	0	0	0	0	0	0	0	
	15	14	13	12	11	10	9	8	7	6	5	4	3	2	1	0	
	reserved									CLKTO	BUSBSY	IDLE	ARBLST	DATACK	ADRACK	ERROR	BUSY
Type	RO	RO	RO	RO	RO	RO	RO	RO	RO	RO	RO	RO	RO	RO	RO	RO	
Reset	0	0	0	0	0	0	0	0	0	0	0	1	0	0	0	0	

Bit/Field	Name	Type	Reset	Description
31	ACTDMARX	RO	0	DMA RX Active Status
				Value Description
				0 DMA RX is not active
				1 DMA RX is active.
30	ACTDMATX	RO	0	DMA TX Active Status
				Value Description
				0 DMA TX is not active
				1 DMA TX is active.

Bit/Field	Name	Type	Reset	Description
29:8	reserved	RO	0x0000.00	Software should not rely on the value of a reserved bit. To provide compatibility with future products, the value of a reserved bit should be preserved across a read-modify-write operation.
7	CLKTO	RO	0	Clock Timeout Error Value Description 0 No clock timeout error. 1 The clock timeout error has occurred. This bit is cleared when the master sends a STOP condition or if the I ² C master is reset.
6	BUSBSY	RO	0	Bus Busy Value Description 0 The I ² C bus is idle. 1 The I ² C bus is busy. The bit changes based on the START and STOP conditions.
5	IDLE	RO	1	I ² C Idle Value Description 0 The I ² C controller is not idle. 1 The I ² C controller is idle.
4	ARBLST	RO	0	Arbitration Lost Value Description 0 The I ² C controller won arbitration. 1 The I ² C controller lost arbitration.
3	DATAACK	RO	0	Acknowledge Data Value Description 0 The transmitted data was acknowledged 1 The transmitted data was not acknowledged.
2	ADRACK	RO	0	Acknowledge Address Value Description 0 The transmitted address was acknowledged 1 The transmitted address was not acknowledged.

Bit/Field	Name	Type	Reset	Description
1	ERROR	RO	0	<p>Error</p> <p>Value Description</p> <p>0 No error was detected on the last operation.</p> <p>1 An error occurred on the last operation.</p> <p>The error can be from the slave address not being acknowledged or the transmit data not being acknowledged.</p>
0	BUSY	RO	0	<p>I²C Busy</p> <p>Value Description</p> <p>0 The controller is idle.</p> <p>1 The controller is busy.</p> <p>When the <i>BUSY</i> bit is set, the other status bits are not valid.</p>

Write-Only Control Register

I2C Master Control/Status (I2CMCS)

I2C 0 base: 0x4002.0000
 I2C 1 base: 0x4002.1000
 I2C 2 base: 0x4002.2000
 I2C 3 base: 0x4002.3000
 I2C 4 base: 0x400C.0000
 I2C 5 base: 0x400C.1000
 I2C 6 base: 0x400C.2000
 I2C 7 base: 0x400C.3000
 I2C 8 base: 0x400B.8000
 I2C 9 base: 0x400B.9000
 Offset 0x004
 Type WO, reset 0x0000.0020

	31	30	29	28	27	26	25	24	23	22	21	20	19	18	17	16	
	reserved																
Type	RO	RO	RO	RO	RO	RO	RO	RO	RO	RO	RO	RO	RO	RO	RO	RO	
Reset	0	0	0	0	0	0	0	0	0	0	0	0	0	0	0	0	
	15	14	13	12	11	10	9	8	7	6	5	4	3	2	1	0	
	reserved										BURST	QCMD	HS	ACK	STOP	START	RUN
Type	RO	RO	RO	RO	RO	RO	RO	RO	RO	RO	WO	WO	WO	WO	WO	WO	
Reset	0	0	0	0	0	0	0	0	0	0	0	0	0	0	0	0	

Bit/Field	Name	Type	Reset	Description
31:7	reserved	RO	0	Software should not rely on the value of a reserved bit. To provide compatibility with future products, the value of a reserved bit should be preserved across a read-modify-write operation.
6	BURST	WO	0	<p>Burst Enable</p> <p>Value Description</p> <p>0 Burst operation is disabled.</p> <p>1 The master is enabled to burst using the receive and transmit FIFOs. See field decoding in Table 21-5 on page 1432.</p>

Note that the *BURST* and *RUN* bits are mutually exclusive.

Bit/Field	Name	Type	Reset	Description
5	QCMD	WO	0	<p>Quick Command</p> <p>Value Description</p> <p>0 Bus transaction is not a quick command.</p> <p>1 The bus transaction is a quick command. To execute a quick command, the <i>START</i>, <i>STOP</i> and <i>RUN</i> bits also need to be set. After the quick command is issued, the master generates a <i>STOP</i>.</p>
4	HS	WO	0	<p>High-Speed Enable</p> <p>Value Description</p> <p>0 The master operates in Standard, Fast mode, or Fast mode plus as selected by using a value in the I2CMTPR register that results in an SCL frequency of 100 kbps for Standard mode, 400 kbps for Fast mode, or 1 Mbps for Fast mode plus.</p> <p>1 The master operates in High-Speed mode with transmission speeds up to 3.33 Mbps.</p>
3	ACK	WO	0	<p>Data Acknowledge Enable</p> <p>Value Description</p> <p>0 The received data byte is not acknowledged automatically by the master.</p> <p>1 The received data byte is acknowledged automatically by the master. See field decoding in Table 21-5 on page 1432.</p>
2	STOP	WO	0	<p>Generate STOP</p> <p>Value Description</p> <p>0 The controller does not generate the STOP condition.</p> <p>1 The controller generates the STOP condition. See field decoding in Table 21-5 on page 1432.</p>
1	START	WO	0	<p>Generate START</p> <p>Value Description</p> <p>0 The controller does not generate the START condition.</p> <p>1 The controller generates the START or repeated START condition. See field decoding in Table 21-5 on page 1432.</p>

Bit/Field	Name	Type	Reset	Description
0	RUN	WO	0	I ² C Master Enable
				Value Description
				0 In standard and high speed mode, this encoding means the master is unable to transmit or receive data. In Burst mode, this bit is not used and must be set to 0.
				1 The master is able to transmit or receive data. Note that this bit cannot be set in Burst mode. See field decoding in Table 21-5 on page 1432.

Note that the `BURST` and `RUN` bits are mutually exclusive.

The Table 21-5 on page 1432 can be read from left to right to determine the next state after programming bits in the `I2CMSA` and `I2CMCS` registers.

Table 21-5. Write Field Decoding for I2CMCS[6:0]

Current State	I2CMSA[0]	I2CMCS[6:0]							Next State Description
	R/S	BURST	QCCMD	HS	ACK	STOP	START	RUN	
Idle	0	0	0	0	X ^a	0	1	1	START condition followed by TRANSMIT (master goes to the Master Transmit state).
	0	0	0	0	X	1	1	1	START condition followed by a TRANSMIT and STOP condition (master remains in Idle state).
	0	1	0	0	X	0	1	0	START condition followed by N FIFO-serviced TRANSMITs (master goes to the Master Transmit state).
	0	1	0	0	X	1	1	0	START condition followed by N FIFO-serviced TRANSMITs and STOP condition (master remains in Idle state).
	1	0	0	0	0	0	1	1	START condition followed by RECEIVE operation with negative ACK (master goes to the Master Receive state).
	0	0	1	0	0	1	1	1	Quick Command (Send). After Quick Command is executed, the master returns to Idle state.
	1	0	1	0	0	1	1	1	Quick Command (Receive). After Quick Command is executed, the master returns to Idle state.
	1	0	0	0	0	1	1	1	START condition followed by RECEIVE and STOP condition (master remains in Idle state).
	1	0	0	0	1	0	1	1	START condition followed by RECEIVE (master goes to the Master Receive state).
	1	1	0	0	0	0	1	0	START condition followed by N FIFO-serviced RECEIVE operations with a negative ACK on the last RECEIVE operation (master goes to the Master Receive state).
	1	1	0	0	0	1	1	0	START condition followed by N FIFO-serviced RECEIVE operations with a negative ACK on the last RECEIVE and STOP condition (master remains in Idle state).
	1	1	0	0	1	0	1	0	START condition followed by N FIFO-serviced RECEIVE operations (master goes to the Master Receive state).
	0	0	0	1	0	0	1	1	START/RUN condition where master byte is sent with no ACK; followed by High Speed transmit Operation. All subsequent transfers are carried out using normal transmit commands.
	0	1	0	1	0	0	0	0	RUN/BURST condition where master byte is sent with no ACK; followed by High Speed Burst transmit Operation.
	1	0	0	0	1	1	1	1	Illegal
1	0	0	0	0	1	1	0	Illegal	
All other combinations not listed are non-operations.									NOP

Table 21-5. Write Field Decoding for I2CMCS[6:0] (continued)

Current State	I2CMSA[0]	I2CMCS[6:0]							Next State Description
	R/S	BURST	QCCMD	HS	ACK	STOP	START	RUN	
Master Transmit	X	0	0	0	X	0	0	1	TRANSMIT operation (master remains in Master Transmit state).
	X	0	0	0	X	1	0	0	STOP condition (master goes to Idle state).
	X	0	0	0	X	1	0	1	TRANSMIT followed by STOP condition (master goes to Idle state).
	X	1	0	0	X	0	0	0	N FIFO-serviced TRANSMIT operations (master remains in Master Transmit state).
	X	1	0	0	X	1	0	0	N FIFO-serviced TRANSMIT operations followed by STOP condition (master goes to Idle state).
	0	0	0	0	X	0	1	1	Repeated START condition followed by a TRANSMIT (master remains in Master Transmit state).
	0	0	0	0	X	1	1	1	Repeated START condition followed by TRANSMIT and STOP condition (master goes to Idle state).
	0	1	0	0	X	0	1	0	Repeated START condition followed by N FIFO-serviced TRANSMIT operations (master remains in Master Transmit state).
	0	1	0	0	X	1	1	0	Repeated START condition followed by N FIFO-serviced TRANSMIT operations and STOP condition (master goes to Idle state).
	1	0	0	0	0	0	1	1	Repeated START condition followed by a RECEIVE operation with a negative ACK (master goes to Master Receive state).
	1	0	0	0	0	1	1	1	Repeated START condition followed by a RECEIVE and STOP condition (master goes to Idle state).
	1	0	0	0	1	0	1	1	Repeated START condition followed by RECEIVE (master goes to Master Receive state).
	1	1	0	0	0	0	1	0	Repeated START condition followed by N FIFO-serviced RECEIVE operations with a negative ACK on the last RECEIVE operation (master goes to Master Receive state).
	1	1	0	0	0	1	1	0	Repeated START condition followed by N FIFO-serviced RECEIVE operations and STOP condition (master goes to Idle state).
	1	1	0	0	1	0	1	0	Repeated START condition followed by N FIFO-serviced RECEIVE operations (master goes to Master Receive state).
	1	0	0	0	1	1	1	1	Illegal.
	1	1	0	0	1	1	1	0	Illegal.
	All other combinations not listed are non-operations.								

Table 21-5. Write Field Decoding for I2CMCS[6:0] (continued)

Current State	I2CMSA[0]	I2CMCS[6:0]							Next State Description	
	R/S	BURST	QCCMD	HS	ACK	STOP	START	RUN		
Master Receive	X	0	0	0	0	0	0	1	RECEIVE operation with negative ACK (master remains in Master Receive state).	
	X	0	0	0	0	X	1	0	STOP condition (master goes to Idle state). ^b	
	X	0	0	0	0	0	1	0	RECEIVE followed by STOP condition (master goes to Idle state).	
	X	0	0	0	0	1	0	0	RECEIVE operation (master remains in Master Receive state).	
	X	1	0	0	0	0	0	0	N FIFO-serviced RECEIVE operations with negative ACK on the last RECEIVE (master remains in Master Receive state).	
	X	1	0	0	0	0	1	0	N FIFO-serviced RECEIVE operations followed by STOP condition (master goes to Idle state).	
	X	1	0	0	0	1	0	0	N FIFO-serviced RECEIVE operations (master remains in Master Receive state).	
	X	0	0	0	0	1	1	0	Illegal.	
	X	1	0	0	0	1	1	0	Illegal.	
	1	0	0	0	0	0	0	1	1	Repeated START condition followed by RECEIVE operation with a negative ACK (master remains in Master Receive state).
	1	0	0	0	0	0	1	1	1	Repeated START condition followed by RECEIVE and STOP condition (master goes to Idle state).
	1	0	0	0	0	1	0	1	1	Repeated START condition followed by RECEIVE (master remains in Master Receive state).
	1	1	0	0	0	0	0	1	0	Repeated START condition followed by N FIFO-serviced RECEIVE operations with a negative ACK on the last RECEIVE (master remains in Master Receive state).
	1	1	0	0	0	0	1	1	0	Repeated START condition followed by N FIFO-serviced RECEIVE operations and STOP condition (master goes to Idle state).
	1	1	0	0	0	1	0	1	0	Repeated START condition followed by N FIFO-serviced RECEIVE operations (master remains in Master Receive state).
	0	0	0	0	0	X	0	1	1	Repeated START condition followed by TRANSMIT (master goes to Master Transmit state).
	0	0	0	0	0	X	1	1	1	Repeated START condition followed by TRANSMIT and STOP condition (master goes to Idle state).
	0	1	0	0	0	X	0	1	0	Repeated START condition followed by N FIFO-serviced TRANSMIT operations (master goes to Master Transmit state).
	0	1	0	0	0	X	1	1	0	Repeated START condition followed by N FIFO-serviced TRANSMIT operations and STOP condition (master goes to Idle state).
All other combinations not listed are non-operations.									NOP.	

a. An X in a table cell indicates the bit can be 0 or 1.

- b. In Master Receive mode, a STOP condition should be generated only after a Data Negative Acknowledge executed by the master or an Address Negative Acknowledge executed by the slave.

Register 3: I²C Master Data (I2CMDR), offset 0x008

Important: This register is read-sensitive. See the register description for details.

This register contains the data to be transmitted when in the Master Transmit state and the data received when in the Master Receive state. If the `BURST` bit is enabled in the `I2CMCS` register, then the `I2CFIFODATA` register is used for the current data transmit or receive value and this register is ignored.

I2C Master Data (I2CMDR)

I2C 0 base: 0x4002.0000
 I2C 1 base: 0x4002.1000
 I2C 2 base: 0x4002.2000
 I2C 3 base: 0x4002.3000
 I2C 4 base: 0x400C.0000
 I2C 5 base: 0x400C.1000
 I2C 6 base: 0x400C.2000
 I2C 7 base: 0x400C.3000
 I2C 8 base: 0x400B.8000
 I2C 9 base: 0x400B.9000
 Offset 0x008
 Type RW, reset 0x0000.0000

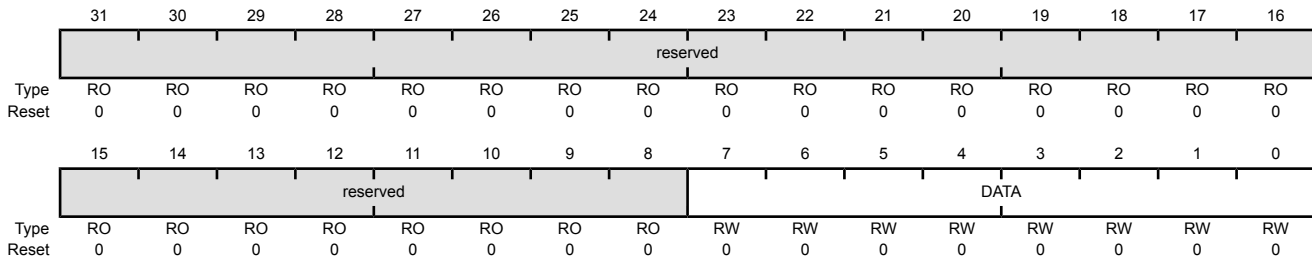

Bit/Field	Name	Type	Reset	Description
31:8	reserved	RO	0x0000.00	Software should not rely on the value of a reserved bit. To provide compatibility with future products, the value of a reserved bit should be preserved across a read-modify-write operation.
7:0	DATA	RW	0x00	This byte contains the data transferred during a transaction.

Register 4: I²C Master Timer Period (I2CMTPR), offset 0x00C

This register is programmed to set the timer period for the SCL clock and assign the SCL clock to either standard or high-speed mode.

I2C Master Timer Period (I2CMTPR)

I2C 0 base: 0x4002.0000
 I2C 1 base: 0x4002.1000
 I2C 2 base: 0x4002.2000
 I2C 3 base: 0x4002.3000
 I2C 4 base: 0x400C.0000
 I2C 5 base: 0x400C.1000
 I2C 6 base: 0x400C.2000
 I2C 7 base: 0x400C.3000
 I2C 8 base: 0x400B.8000
 I2C 9 base: 0x400B.9000
 Offset 0x00C
 Type RW, reset 0x0000.0001

	31	30	29	28	27	26	25	24	23	22	21	20	19	18	17	16
	reserved													PULSESEL		
Type	RO	RO	RO	RO	RO	RO	RO	RO	RO	RO	RO	RO	RO	RW	RW	RW
Reset	0	0	0	0	0	0	0	0	0	0	0	0	0	0	0	0
	15	14	13	12	11	10	9	8	7	6	5	4	3	2	1	0
	reserved								HS	TPR						
Type	RO	RO	RO	RO	RO	RO	RO	RO	WO	RW	RW	RW	RW	RW	RW	RW
Reset	0	0	0	0	0	0	0	0	0	0	0	0	0	0	0	1

Bit/Field	Name	Type	Reset	Description																		
31:19	reserved	RO	0x0000.00	Software should not rely on the value of a reserved bit. To provide compatibility with future products, the value of a reserved bit should be preserved across a read-modify-write operation.																		
18:16	PULSESEL	RW	0x0	Glitch Suppression Pulse Width This field controls the pulse width select for glitch suppression on the SCL and SDA lines. The following values are the glitch suppression values in terms of system clocks. <table border="0"> <thead> <tr> <th>Value</th> <th>Description</th> </tr> </thead> <tbody> <tr> <td>0x0</td> <td>Bypass</td> </tr> <tr> <td>0x1</td> <td>1 clock</td> </tr> <tr> <td>0x2</td> <td>2 clocks</td> </tr> <tr> <td>0x3</td> <td>3 clocks</td> </tr> <tr> <td>0x4</td> <td>4 clocks</td> </tr> <tr> <td>0x5</td> <td>8 clocks</td> </tr> <tr> <td>0x6</td> <td>16 clocks</td> </tr> <tr> <td>0x7</td> <td>31 clocks</td> </tr> </tbody> </table>	Value	Description	0x0	Bypass	0x1	1 clock	0x2	2 clocks	0x3	3 clocks	0x4	4 clocks	0x5	8 clocks	0x6	16 clocks	0x7	31 clocks
Value	Description																					
0x0	Bypass																					
0x1	1 clock																					
0x2	2 clocks																					
0x3	3 clocks																					
0x4	4 clocks																					
0x5	8 clocks																					
0x6	16 clocks																					
0x7	31 clocks																					
15:8	reserved	RO	0x0000.00	Software should not rely on the value of a reserved bit. To provide compatibility with future products, the value of a reserved bit should be preserved across a read-modify-write operation.																		

Bit/Field	Name	Type	Reset	Description
7	HS	WO	0x0	High-Speed Enable Value Description 0 The SCL Clock Period set by TPR applies to Standard mode (100 Kbps), Fast-mode (400 Kbps), or Fast-mode plus (1 Mbps). 1 The SCL Clock Period set by TPR applies to High-speed mode (3.33 Mbps).
6:0	TPR	RW	0x1	Timer Period This field is used in the equation to configure <i>SCL_PERIOD</i> : $SCL_PERIOD = 2 \times (1 + TPR) \times (SCL_LP + SCL_HP) \times CLK_PRD$ where: <i>SCL_PRD</i> is the SCL line period (I ² C clock). <i>TPR</i> is the Timer Period register value (range of 1 to 127). <i>SCL_LP</i> is the SCL Low period (fixed at 6). <i>SCL_HP</i> is the SCL High period (fixed at 4). <i>CLK_PRD</i> is the system clock period in ns.

Register 5: I²C Master Interrupt Mask (I2CMIMR), offset 0x010

This register controls whether a raw interrupt is promoted to a controller interrupt.

I2C Master Interrupt Mask (I2CMIMR)

I2C 0 base: 0x4002.0000
 I2C 1 base: 0x4002.1000
 I2C 2 base: 0x4002.2000
 I2C 3 base: 0x4002.3000
 I2C 4 base: 0x400C.0000
 I2C 5 base: 0x400C.1000
 I2C 6 base: 0x400C.2000
 I2C 7 base: 0x400C.3000
 I2C 8 base: 0x400B.8000
 I2C 9 base: 0x400B.9000
 Offset 0x010
 Type RW, reset 0x0000.0000

	31	30	29	28	27	26	25	24	23	22	21	20	19	18	17	16
	reserved															
Type	RO	RO	RO	RO	RO	RO	RO	RO	RO	RO	RO	RO	RO	RO	RO	RO
Reset	0	0	0	0	0	0	0	0	0	0	0	0	0	0	0	0
	15	14	13	12	11	10	9	8	7	6	5	4	3	2	1	0
	reserved				RXFFIM	TXFEIM	RXIM	TXIM	ARBLOSTIM	STOPIM	STARTIM	NACKIM	DMATXIM	DMARXIM	CLKIM	IM
Type	RO	RO	RO	RO	RW	RW	RW	RW	RW	RW	RW	RW	RW	RW	RW	RW
Reset	0	0	0	0	0	0	0	0	0	0	0	0	0	0	0	0

Bit/Field	Name	Type	Reset	Description
31:12	reserved	RO	0	Software should not rely on the value of a reserved bit. To provide compatibility with future products, the value of a reserved bit should be preserved across a read-modify-write operation.
11	RXFFIM	RW	0	Receive FIFO Full Interrupt Mask Value Description 0 The RXFFRIS interrupt is suppressed and not sent to the interrupt controller. 1 The Receive FIFO Full interrupt is sent to the interrupt controller when the RXFFRIS bit in the I2CMRIS register is set.
10	TXFEIM	RW	0	Transmit FIFO Empty Interrupt Mask Note: The TXFEIM interrupt mask bit in the I2CMIMR register should be clear (masking the TXFE interrupt) when the master is performing an RX Burst from the RXFIFO and should be unmasked before starting a TX FIFO transfers. Value Description 0 The TXFERIS interrupt is suppressed and not sent to the interrupt controller. 1 The Transmit FIFO Empty interrupt is sent to the interrupt controller when the TXFERIS bit in the I2CMRIS register is set.

Bit/Field	Name	Type	Reset	Description
9	RXIM	RW	0	Receive FIFO Request Interrupt Mask Value Description 0 The <code>RXRIS</code> interrupt is suppressed and not sent to the interrupt controller. 1 The RX FIFO Request interrupt is sent to the interrupt controller when the <code>RXRIS</code> bit in the I2CMRIS register is set.
8	TXIM	RW	0	Transmit FIFO Request Interrupt Mask Value Description 0 The <code>TXRIS</code> interrupt is suppressed and not sent to the interrupt controller. 1 The TX FIFO Request interrupt is sent to the interrupt controller when the <code>TXRIS</code> bit in the I2CMRIS register is set.
7	ARBLOSTIM	RW	0	Arbitration Lost Interrupt Mask Value Description 0 The <code>ARBLOSTRIS</code> interrupt is suppressed and not sent to the interrupt controller. 1 The Arbitration Lost interrupt is sent to the interrupt controller when the <code>ARBLOSTRIS</code> bit in the I2CMRIS register is set.
6	STOPIIM	RW	0	STOP Detection Interrupt Mask Value Description 0 The <code>STOPRIS</code> interrupt is suppressed and not sent to the interrupt controller. 1 The STOP detection interrupt is sent to the interrupt controller when the <code>STOPRIS</code> bit in the I2CMRIS register is set.
5	STARTIM	RW	0	START Detection Interrupt Mask Value Description 0 The <code>STARTRIS</code> interrupt is suppressed and not sent to the interrupt controller. 1 The START detection interrupt is sent to the interrupt controller when the <code>STARTRIS</code> bit in the I2CMRIS register is set.
4	NACKIM	RW	0	Address/Data NACK Interrupt Mask Value Description 0 The <code>NACKRIS</code> interrupt is suppressed and not sent to the interrupt controller. 1 The address/data NACK interrupt is sent to the interrupt controller when the <code>NACKRIS</code> bit in the I2CMRIS register is set.

Bit/Field	Name	Type	Reset	Description
3	DMATXIM	RW	0	Transmit DMA Interrupt Mask Value Description 0 The <i>DMATXRIS</i> interrupt is suppressed and not sent to the interrupt controller. 1 The transmit DMA complete interrupt is sent to the interrupt controller when the <i>DMATXRIS</i> bit in the I2CMRIS register is set.
2	DMARXIM	RW	0	Receive DMA Interrupt Mask Value Description 0 The <i>DMARXRIS</i> interrupt is suppressed and not sent to the interrupt controller. 1 The receive DMA complete interrupt is sent to the interrupt controller when the <i>DMARXRIS</i> bit in the I2CMRIS register is set.
1	CLKIM	RW	0	Clock Timeout Interrupt Mask Value Description 0 The <i>CLKRIS</i> interrupt is suppressed and not sent to the interrupt controller. 1 The clock timeout interrupt is sent to the interrupt controller when the <i>CLKRIS</i> bit in the I2CMRIS register is set.
0	IM	RW	0	Master Interrupt Mask Value Description 0 The <i>RIS</i> interrupt is suppressed and not sent to the interrupt controller. 1 The master interrupt is sent to the interrupt controller when the <i>RIS</i> bit in the I2CMRIS register is set.

Register 6: I²C Master Raw Interrupt Status (I2CMRIS), offset 0x014

This register specifies whether an interrupt is pending.

I2C Master Raw Interrupt Status (I2CMRIS)

I2C 0 base: 0x4002.0000
 I2C 1 base: 0x4002.1000
 I2C 2 base: 0x4002.2000
 I2C 3 base: 0x4002.3000
 I2C 4 base: 0x400C.0000
 I2C 5 base: 0x400C.1000
 I2C 6 base: 0x400C.2000
 I2C 7 base: 0x400C.3000
 I2C 8 base: 0x400B.8000
 I2C 9 base: 0x400B.9000
 Offset 0x014
 Type RO, reset 0x0000.0000

	31	30	29	28	27	26	25	24	23	22	21	20	19	18	17	16
	reserved															
Type	RO	RO	RO	RO	RO	RO	RO	RO	RO	RO	RO	RO	RO	RO	RO	RO
Reset	0	0	0	0	0	0	0	0	0	0	0	0	0	0	0	0
	15	14	13	12	11	10	9	8	7	6	5	4	3	2	1	0
	reserved				RXFFRIS	TXFERIS	RXRIS	TXRIS	ARBLOSTRIS	STOPRIS	STARTRIS	NACKRIS	DMATXRIS	DMARXRIS	CLKRIS	RIS
Type	RO	RO	RO	RO	RO	RO	RO	RO	RO	RO	RO	RO	RO	RO	RO	RO
Reset	0	0	0	0	0	0	0	0	0	0	0	0	0	0	0	0

Bit/Field	Name	Type	Reset	Description
31:12	reserved	RO	0	Software should not rely on the value of a reserved bit. To provide compatibility with future products, the value of a reserved bit should be preserved across a read-modify-write operation.
11	RXFFRIS	RO	0	Receive FIFO Full Raw Interrupt Status Value Description 0 No interrupt 1 The Receive FIFO Full interrupt is pending. This bit is cleared by writing a 1 to the <code>RXFFIC</code> bit in the I2CMICR register.
10	TXFERIS	RO	0	Transmit FIFO Empty Raw Interrupt Status Value Description 0 No interrupt 1 The Transmit FIFO Empty interrupt is pending. This bit is cleared by writing a 1 to the <code>TXFEIC</code> bit in the I2CMICR register. Note that if we clear the <code>TXFERIS</code> interrupt (by setting the <code>TXFEIC</code> bit) when the TX FIFO is empty, the <code>TXFERIS</code> interrupt does not reassert even though the TX FIFO remains empty in this situation.

Bit/Field	Name	Type	Reset	Description
9	RXRIS	RO	0	<p>Receive FIFO Request Raw Interrupt Status</p> <p>Value Description</p> <p>0 No interrupt</p> <p>1 The trigger level for the RX FIFO has been reached or there is data in the FIFO and the burst count is zero. Thus, a RX FIFO request interrupt is pending.</p> <p>This bit is cleared by writing a 1 to the <code>RXIC</code> bit in the I2CMICR register.</p>
8	TXRIS	RO	0	<p>Transmit Request Raw Interrupt Status</p> <p>Value Description</p> <p>0 No interrupt</p> <p>1 The trigger level for the TX FIFO has been reached and more data is needed to complete the burst. Thus, a TX FIFO request interrupt is pending.</p> <p>This bit is cleared by writing a 1 to the <code>TXIC</code> bit in the I2CMICR register.</p>
7	ARBLOSTRIS	RO	0	<p>Arbitration Lost Raw Interrupt Status</p> <p>Value Description</p> <p>0 No interrupt</p> <p>1 The Arbitration Lost interrupt is pending.</p> <p>This bit is cleared by writing a 1 to the <code>ARBLOSTIC</code> bit in the I2CMICR register.</p>
6	STOPRIS	RO	0	<p>STOP Detection Raw Interrupt Status</p> <p>Value Description</p> <p>0 No interrupt</p> <p>1 The STOP Detection interrupt is pending.</p> <p>This bit is cleared by writing a 1 to the <code>STOPIC</code> bit in the I2CMICR register.</p>
5	STARTRIS	RO	0	<p>START Detection Raw Interrupt Status</p> <p>Value Description</p> <p>0 No interrupt</p> <p>1 The START Detection interrupt is pending.</p> <p>This bit is cleared by writing a 1 to the <code>STARTIC</code> bit in the I2CMICR register.</p>
4	NACKRIS	RO	0	<p>Address/Data NACK Raw Interrupt Status</p> <p>Value Description</p> <p>0 No interrupt</p> <p>1 The address/data NACK interrupt is pending.</p> <p>This bit is cleared by writing a 1 to the <code>NACKIC</code> bit in the I2CMICR register.</p>

Bit/Field	Name	Type	Reset	Description
3	DMATXRIS	RO	0	<p>Transmit DMA Raw Interrupt Status</p> <p>Value Description</p> <p>0 No interrupt.</p> <p>1 The transmit DMA complete interrupt is pending.</p> <p>This bit is cleared by writing a 1 to the <code>DMATXIC</code> bit in the I2CMICR register.</p>
2	DMARXRIS	RO	0	<p>Receive DMA Raw Interrupt Status</p> <p>Value Description</p> <p>0 No interrupt.</p> <p>1 The receive DMA complete interrupt is pending.</p> <p>This bit is cleared by writing a 1 to the <code>DMARXIC</code> bit in the I2CMICR register.</p>
1	CLKRIS	RO	0	<p>Clock Timeout Raw Interrupt Status</p> <p>Value Description</p> <p>0 No interrupt.</p> <p>1 The clock timeout interrupt is pending.</p> <p>This bit is cleared by writing a 1 to the <code>CLKIC</code> bit in the I2CMICR register.</p>
0	RIS	RO	0	<p>Master Raw Interrupt Status</p> <p>This interrupt includes:</p> <ul style="list-style-type: none"> ■ Master transaction completed ■ Next byte transfer request <p>Value Description</p> <p>0 No interrupt.</p> <p>1 A master interrupt is pending.</p> <p>This bit is cleared by writing a 1 to the <code>IC</code> bit in the I2CMICR register.</p>

Register 7: I²C Master Masked Interrupt Status (I2CMMIS), offset 0x018

This register specifies whether an interrupt was signaled.

I2C Master Masked Interrupt Status (I2CMMIS)

I2C 0 base: 0x4002.0000
 I2C 1 base: 0x4002.1000
 I2C 2 base: 0x4002.2000
 I2C 3 base: 0x4002.3000
 I2C 4 base: 0x400C.0000
 I2C 5 base: 0x400C.1000
 I2C 6 base: 0x400C.2000
 I2C 7 base: 0x400C.3000
 I2C 8 base: 0x400B.8000
 I2C 9 base: 0x400B.9000
 Offset 0x018
 Type RO, reset 0x0000.0000

	31	30	29	28	27	26	25	24	23	22	21	20	19	18	17	16
	reserved															
Type	RO	RO	RO	RO	RO	RO	RO	RO	RO	RO	RO	RO	RO	RO	RO	RO
Reset	0	0	0	0	0	0	0	0	0	0	0	0	0	0	0	0
	15	14	13	12	11	10	9	8	7	6	5	4	3	2	1	0
	reserved				RXFFMIS	TXFEMIS	RXMIS	TXMIS	ARBLOSTMIS	STOPMIS	STARTMIS	NACKMIS	DMATXMIS	DMARXMIS	CLKMIS	MIS
Type	RO	RO	RO	RO	RO	RO	RO	RO	RO	RO	RO	RO	RO	RO	RO	RO
Reset	0	0	0	0	0	0	0	0	0	0	0	0	0	0	0	0

Bit/Field	Name	Type	Reset	Description
31:12	reserved	RO	0	Software should not rely on the value of a reserved bit. To provide compatibility with future products, the value of a reserved bit should be preserved across a read-modify-write operation.
11	RXFFMIS	RO	0	Receive FIFO Full Interrupt Mask Value Description 0 No interrupt. 1 An unmasked Receive FIFO Full interrupt was signaled and is pending. This bit is cleared by writing a 1 to the RXFFIC bit in the I2CMICR register.
10	TXFEMIS	RO	0	Transmit FIFO Empty Interrupt Mask Value Description 0 No interrupt. 1 An unmasked Transmit FIFO Empty interrupt was signaled and is pending. This bit is cleared by writing a 1 to the TXFEIC bit in the I2CMICR register.

Bit/Field	Name	Type	Reset	Description
9	RXMIS	RO	0	<p>Receive FIFO Request Interrupt Mask</p> <p>Value Description</p> <p>0 No interrupt.</p> <p>1 An unmasked Receive FIFO Request interrupt was signaled and is pending.</p> <p>This bit is cleared by writing a 1 to the <code>RXIC</code> bit in the I2CMICR register.</p>
8	TXMIS	RO	0	<p>Transmit Request Interrupt Mask</p> <p>Value Description</p> <p>0 No interrupt.</p> <p>1 An unmasked Transmit FIFO Request interrupt was signaled and is pending.</p> <p>This bit is cleared by writing a 1 to the <code>TXIC</code> bit in the I2CMICR register.</p>
7	ARBLOSTMIS	RO	0	<p>Arbitration Lost Interrupt Mask</p> <p>Value Description</p> <p>0 No interrupt.</p> <p>1 An unmasked Arbitration Lost interrupt was signaled and is pending.</p> <p>This bit is cleared by writing a 1 to the <code>ARBLOSTIC</code> bit in the I2CMICR register.</p>
6	STOPMIS	RO	0	<p>STOP Detection Interrupt Mask</p> <p>Value Description</p> <p>0 No interrupt.</p> <p>1 An unmasked STOP Detection interrupt was signaled and is pending.</p> <p>This bit is cleared by writing a 1 to the <code>STOPIC</code> bit in the I2CMICR register.</p>
5	STARTMIS	RO	0	<p>START Detection Interrupt Mask</p> <p>Value Description</p> <p>0 No interrupt.</p> <p>1 An unmasked START Detection interrupt was signaled and is pending.</p> <p>This bit is cleared by writing a 1 to the <code>STARTIC</code> bit in the I2CMICR register.</p>

Bit/Field	Name	Type	Reset	Description
4	NACKMIS	RO	0	<p>Address/Data NACK Interrupt Mask</p> <p>Value Description</p> <p>0 No interrupt.</p> <p>1 An unmasked Address/Data NACK interrupt was signaled and is pending.</p> <p>This bit is cleared by writing a 1 to the NACKIC bit in the I2CMICR register.</p>
3	DMATXMIS	RO	0	<p>Transmit DMA Interrupt Status</p> <p>Value Description</p> <p>0 No interrupt.</p> <p>1 An unmasked transmit DMA complete interrupt was signaled and is pending.</p> <p>This bit is cleared by writing a 1 to the DMATXIC bit in the I2CMICR register.</p>
2	DMARXMIS	RO	0	<p>Receive DMA Interrupt Status</p> <p>Value Description</p> <p>0 No interrupt.</p> <p>1 An unmasked receive DMA complete interrupt was signaled and is pending.</p> <p>This bit is cleared by writing a 1 to the DMARXIC bit in the I2CMICR register.</p>
1	CLKMIS	RO	0	<p>Clock Timeout Masked Interrupt Status</p> <p>Value Description</p> <p>0 No interrupt.</p> <p>1 An unmasked clock timeout interrupt was signaled and is pending.</p> <p>This bit is cleared by writing a 1 to the CLKIC bit in the I2CMICR register.</p>
0	MIS	RO	0	<p>Masked Interrupt Status</p> <p>Value Description</p> <p>0 An interrupt has not occurred or is masked.</p> <p>1 An unmasked master interrupt was signaled and is pending.</p> <p>This bit is cleared by writing a 1 to the IC bit in the I2CMICR register.</p>

Register 8: I²C Master Interrupt Clear (I2CMICR), offset 0x01C

This register clears the raw and masked interrupts.

I2C Master Interrupt Clear (I2CMICR)

I2C 0 base: 0x4002.0000
 I2C 1 base: 0x4002.1000
 I2C 2 base: 0x4002.2000
 I2C 3 base: 0x4002.3000
 I2C 4 base: 0x400C.0000
 I2C 5 base: 0x400C.1000
 I2C 6 base: 0x400C.2000
 I2C 7 base: 0x400C.3000
 I2C 8 base: 0x400B.8000
 I2C 9 base: 0x400B.9000
 Offset 0x01C
 Type WO, reset 0x0000.0000

	31	30	29	28	27	26	25	24	23	22	21	20	19	18	17	16
	reserved															
Type	RO	RO	RO	RO	RO	RO	RO	RO	RO	RO	RO	RO	RO	RO	RO	RO
Reset	0	0	0	0	0	0	0	0	0	0	0	0	0	0	0	0
	15	14	13	12	11	10	9	8	7	6	5	4	3	2	1	0
	reserved				RXFFIC	TXFEIC	RXIC	TXIC	ARBLOSTIC	STOPIC	STARTIC	NACKIC	DMATXIC	DMARXIC	CLKIC	IC
Type	RO	RO	RO	RO	WO	WO	WO	WO	WO	WO	WO	WO	WO	WO	WO	WO
Reset	0	0	0	0	0	0	0	0	0	0	0	0	0	0	0	0

Bit/Field	Name	Type	Reset	Description
31:12	reserved	RO	0	Software should not rely on the value of a reserved bit. To provide compatibility with future products, the value of a reserved bit should be preserved across a read-modify-write operation.
11	RXFFIC	WO	0	Receive FIFO Full Interrupt Clear Writing a 1 to this bit clears the RXFFIS bit in the I2CMRIS register and the RXFFMIS bit in the I2CMMIS register. A read of this register returns no meaningful data.
10	TXFEIC	WO	0	Transmit FIFO Empty Interrupt Clear Writing a 1 to this bit clears the TXFERIS bit in the I2CMRIS register and the TXFEMIS bit in the I2CMMIS register. A read of this register returns no meaningful data.
9	RXIC	WO	0	Receive FIFO Request Interrupt Clear Writing a 1 to this bit clears the RXRIS bit in the I2CMRIS register and the RXMIS bit in the I2CMMIS register. A read of this register returns no meaningful data.
8	TXIC	WO	0	Transmit FIFO Request Interrupt Clear Writing a 1 to this bit clears the TXRIS bit in the I2CMRIS register and the TXMIS bit in the I2CMMIS register. A read of this register returns no meaningful data.
7	ARBLOSTIC	WO	0	Arbitration Lost Interrupt Clear Writing a 1 to this bit clears the ARBLOSTRIS bit in the I2CMRIS register and the ARBLOSTMIS bit in the I2CMMIS register. A read of this register returns no meaningful data.

Bit/Field	Name	Type	Reset	Description
6	STOPIC	WO	0	<p>STOP Detection Interrupt Clear</p> <p>Writing a 1 to this bit clears the <code>STOPRIS</code> bit in the <code>I2CMRIS</code> register and the <code>STOPMIS</code> bit in the <code>I2CMMIS</code> register.</p> <p>A read of this register returns no meaningful data.</p>
5	STARTIC	WO	0	<p>START Detection Interrupt Clear</p> <p>Writing a 1 to this bit clears the <code>STARTRIS</code> bit in the <code>I2CMRIS</code> register and the <code>STARTMIS</code> bit in the <code>I2CMMIS</code> register.</p> <p>A read of this register returns no meaningful data.</p>
4	NACKIC	WO	0	<p>Address/Data NACK Interrupt Clear</p> <p>Writing a 1 to this bit clears the <code>NACKRIS</code> bit in the <code>I2CMRIS</code> register and the <code>NACKMIS</code> bit in the <code>I2CMMIS</code> register.</p> <p>A read of this register returns no meaningful data.</p>
3	DMATXIC	WO	0	<p>Transmit DMA Interrupt Clear</p> <p>Writing a 1 to this bit clears the <code>DMATXRIS</code> bit in the <code>I2CMRIS</code> register and the <code>DMATXMIS</code> bit in the <code>I2CMMIS</code> register.</p> <p>A read of this register returns no meaningful data.</p>
2	DMARXIC	WO	0	<p>Receive DMA Interrupt Clear</p> <p>Writing a 1 to this bit clears the <code>DMARXRIS</code> bit in the <code>I2CMRIS</code> register and the <code>DMARXMIS</code> bit in the <code>I2CMMIS</code> register.</p> <p>A read of this register returns no meaningful data.</p>
1	CLKIC	WO	0	<p>Clock Timeout Interrupt Clear</p> <p>Writing a 1 to this bit clears the <code>CLKRIS</code> bit in the <code>I2CMRIS</code> register and the <code>CLKMIS</code> bit in the <code>I2CMMIS</code> register.</p> <p>A read of this register returns no meaningful data.</p>
0	IC	WO	0	<p>Master Interrupt Clear</p> <p>Writing a 1 to this bit clears the <code>RIS</code> bit in the <code>I2CMRIS</code> register and the <code>MIS</code> bit in the <code>I2CMMIS</code> register.</p> <p>A read of this register returns no meaningful data.</p>

Register 9: I²C Master Configuration (I2CMCR), offset 0x020

This register configures the mode (Master or Slave), and sets the interface for test mode loopback.

I2C Master Configuration (I2CMCR)

I2C 0 base: 0x4002.0000
 I2C 1 base: 0x4002.1000
 I2C 2 base: 0x4002.2000
 I2C 3 base: 0x4002.3000
 I2C 4 base: 0x400C.0000
 I2C 5 base: 0x400C.1000
 I2C 6 base: 0x400C.2000
 I2C 7 base: 0x400C.3000
 I2C 8 base: 0x400B.8000
 I2C 9 base: 0x400B.9000
 Offset 0x020
 Type RW, reset 0x0000.0000

	31	30	29	28	27	26	25	24	23	22	21	20	19	18	17	16
	reserved															
Type	RO	RO	RO	RO	RO	RO	RO	RO	RO	RO	RO	RO	RO	RO	RO	RO
Reset	0	0	0	0	0	0	0	0	0	0	0	0	0	0	0	0
	15	14	13	12	11	10	9	8	7	6	5	4	3	2	1	0
	reserved										SFE	MFE	reserved			LPBK
Type	RO	RO	RO	RO	RO	RO	RO	RO	RO	RO	RW	RW	RO	RO	RO	RW
Reset	0	0	0	0	0	0	0	0	0	0	0	0	0	0	0	0

Bit/Field	Name	Type	Reset	Description
31:6	reserved	RO	0x0000.00	Software should not rely on the value of a reserved bit. To provide compatibility with future products, the value of a reserved bit should be preserved across a read-modify-write operation.
5	SFE	RW	0	I ² C Slave Function Enable Value Description 0 Slave mode is disabled. 1 Slave mode is enabled.
4	MFE	RW	0	I ² C Master Function Enable Value Description 0 Master mode is disabled. 1 Master mode is enabled.
3:1	reserved	RO	0x0	Software should not rely on the value of a reserved bit. To provide compatibility with future products, the value of a reserved bit should be preserved across a read-modify-write operation.
0	LPBK	RW	0	I ² C Loopback Value Description 0 Normal operation. 1 The controller in a test mode loopback configuration.

Register 10: I²C Master Clock Low Timeout Count (I2CMCLKOCNT), offset 0x024

This register contains the upper 8 bits of a 12-bit counter that can be used to keep the timeout limit for clock stretching by a remote slave. The lower four bits of the counter are not user visible and are always 0x0.

Note: The Master Clock Low Timeout counter counts for the entire time `SCL` is held Low continuously. If `SCL` is deasserted at any point, the Master Clock Low Timeout Counter is reloaded with the value in the `I2CMCLKOCNT` register and begins counting down from this value.

I2C Master Clock Low Timeout Count (I2CMCLKOCNT)

I2C 0 base: 0x4002.0000
 I2C 1 base: 0x4002.1000
 I2C 2 base: 0x4002.2000
 I2C 3 base: 0x4002.3000
 I2C 4 base: 0x400C.0000
 I2C 5 base: 0x400C.1000
 I2C 6 base: 0x400C.2000
 I2C 7 base: 0x400C.3000
 I2C 8 base: 0x400B.8000
 I2C 9 base: 0x400B.9000
 Offset 0x024
 Type RW, reset 0x0000.0000

	31	30	29	28	27	26	25	24	23	22	21	20	19	18	17	16
	reserved															
Type	RO	RO	RO	RO	RO	RO	RO	RO	RO	RO	RO	RO	RO	RO	RO	RO
Reset	0	0	0	0	0	0	0	0	0	0	0	0	0	0	0	0
	15	14	13	12	11	10	9	8	7	6	5	4	3	2	1	0
	reserved								CNTL							
Type	RO	RO	RO	RO	RO	RO	RO	RO	RW	RW	RW	RW	RW	RW	RW	RW
Reset	0	0	0	0	0	0	0	0	0	0	0	0	0	0	0	0

Bit/Field	Name	Type	Reset	Description
31:8	reserved	RO	0x0000.00	Software should not rely on the value of a reserved bit. To provide compatibility with future products, the value of a reserved bit should be preserved across a read-modify-write operation.
7:0	CNTL	RW	0	I ² C Master Count This field contains the upper 8 bits of a 12-bit counter for the clock low timeout count. Note: The value of CNTL must be greater than 0x1.

Register 11: I²C Master Bus Monitor (I2CMBMON), offset 0x02C

This register is used to determine the SCL and SDA signal status.

I2C Master Bus Monitor (I2CMBMON)

I2C 0 base: 0x4002.0000
 I2C 1 base: 0x4002.1000
 I2C 2 base: 0x4002.2000
 I2C 3 base: 0x4002.3000
 I2C 4 base: 0x400C.0000
 I2C 5 base: 0x400C.1000
 I2C 6 base: 0x400C.2000
 I2C 7 base: 0x400C.3000
 I2C 8 base: 0x400B.8000
 I2C 9 base: 0x400B.9000
 Offset 0x02C
 Type RO, reset 0x0000.0003

	31	30	29	28	27	26	25	24	23	22	21	20	19	18	17	16	
	reserved																
Type	RO	RO	RO	RO	RO	RO	RO	RO	RO	RO	RO	RO	RO	RO	RO	RO	
Reset	0	0	0	0	0	0	0	0	0	0	0	0	0	0	0	0	
	15	14	13	12	11	10	9	8	7	6	5	4	3	2	1	0	
	reserved															SDA	SCL
Type	RO	RO	RO	RO	RO	RO	RO	RO	RO	RO	RO	RO	RO	RO	RO	RO	RO
Reset	0	0	0	0	0	0	0	0	0	0	0	0	0	0	0	1	1

Bit/Field	Name	Type	Reset	Description
31:2	reserved	RO	0x0000.000	Software should not rely on the value of a reserved bit. To provide compatibility with future products, the value of a reserved bit should be preserved across a read-modify-write operation.
1	SDA	RO	1	I ² C SDA Status Value Description 0 The I2CSDA signal is low. 1 The I2CSDA signal is high.
0	SCL	RO	1	I ² C SCL Status Value Description 0 The I2CSCL signal is low. 1 The I2CSCL signal is high.

Register 12: I²C Master Burst Length (I2CMBLEN), offset 0x030

This register contains the programmed length of bytes that are transferred during a Burst request.

I2C Master Burst Length (I2CMBLEN)

I2C 0 base: 0x4002.0000
 I2C 1 base: 0x4002.1000
 I2C 2 base: 0x4002.2000
 I2C 3 base: 0x4002.3000
 I2C 4 base: 0x400C.0000
 I2C 5 base: 0x400C.1000
 I2C 6 base: 0x400C.2000
 I2C 7 base: 0x400C.3000
 I2C 8 base: 0x400B.8000
 I2C 9 base: 0x400B.9000
 Offset 0x030
 Type RW, reset 0x0000.0000

	31	30	29	28	27	26	25	24	23	22	21	20	19	18	17	16
	reserved															
Type	RO	RO	RO	RO	RO	RO	RO	RO	RO	RO	RO	RO	RO	RO	RO	RO
Reset	0	0	0	0	0	0	0	0	0	0	0	0	0	0	0	0
	15	14	13	12	11	10	9	8	7	6	5	4	3	2	1	0
	reserved								CNTL							
Type	RO	RO	RO	RO	RO	RO	RO	RO	RW	RW	RW	RW	RW	RW	RW	RW
Reset	0	0	0	0	0	0	0	0	0	0	0	0	0	0	0	0

Bit/Field	Name	Type	Reset	Description
31:8	reserved	RO	0x0000.00	Software should not rely on the value of a reserved bit. To provide compatibility with future products, the value of a reserved bit should be preserved across a read-modify-write operation.
7:0	CNTL	RW	0	I ² C Burst Length This field contains the programmed length of bytes of the Burst Transaction. If BURST is enabled this register must be set to a non-zero value otherwise an error will occur.

Register 13: I²C Master Burst Count (I2CMBCNT), offset 0x034

When BURST is active, the value in the I2CMBLEN register is copied into this register and decremented during the BURST transaction. This register can be used to determine the number of transfers that occurred when a BURST terminates early (as a result of a data NACK). When a BURST completes successfully, this register will contain 0.

I2C Master Burst Count (I2CMBCNT)

I2C 0 base: 0x4002.0000
 I2C 1 base: 0x4002.1000
 I2C 2 base: 0x4002.2000
 I2C 3 base: 0x4002.3000
 I2C 4 base: 0x400C.0000
 I2C 5 base: 0x400C.1000
 I2C 6 base: 0x400C.2000
 I2C 7 base: 0x400C.3000
 I2C 8 base: 0x400B.8000
 I2C 9 base: 0x400B.9000
 Offset 0x034
 Type RO, reset 0x0000.0000

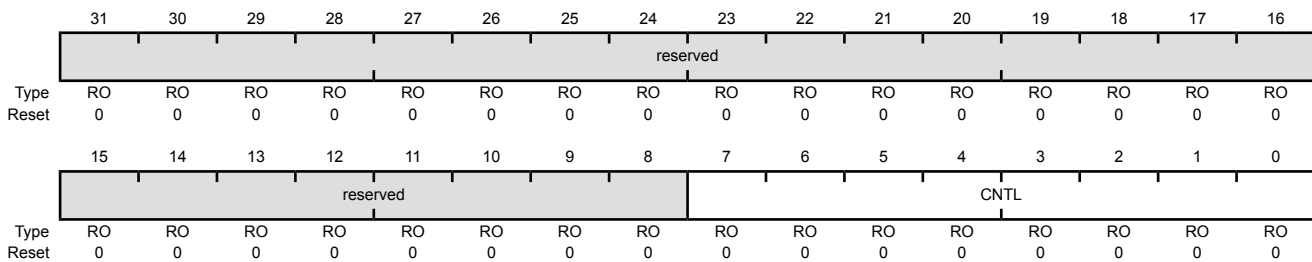

Bit/Field	Name	Type	Reset	Description
31:8	reserved	RO	0x0000.00	Software should not rely on the value of a reserved bit. To provide compatibility with future products, the value of a reserved bit should be preserved across a read-modify-write operation.
7:0	CNTL	RO	0	I ² C Master Burst Count This field contains the current count-down value of the BURST transaction.

21.7 Register Descriptions (I²C Slave)

The remainder of this section lists and describes the I²C slave registers, in numerical order by address offset.

Register 14: I²C Slave Own Address (I2CSOAR), offset 0x800

This register consists of seven address bits that identify the TM4C129ENCPDT I²C device on the I²C bus.

I²C Slave Own Address (I2CSOAR)

I2C 0 base: 0x4002.0000
 I2C 1 base: 0x4002.1000
 I2C 2 base: 0x4002.2000
 I2C 3 base: 0x4002.3000
 I2C 4 base: 0x400C.0000
 I2C 5 base: 0x400C.1000
 I2C 6 base: 0x400C.2000
 I2C 7 base: 0x400C.3000
 I2C 8 base: 0x400B.8000
 I2C 9 base: 0x400B.9000
 Offset 0x800
 Type RW, reset 0x0000.0000

	31	30	29	28	27	26	25	24	23	22	21	20	19	18	17	16
	reserved															
Type	RO	RO	RO	RO	RO	RO	RO	RO	RO	RO	RO	RO	RO	RO	RO	RO
Reset	0	0	0	0	0	0	0	0	0	0	0	0	0	0	0	0
	15	14	13	12	11	10	9	8	7	6	5	4	3	2	1	0
	reserved									OAR						
Type	RO	RO	RO	RO	RO	RO	RO	RO	RO	RW	RW	RW	RW	RW	RW	RW
Reset	0	0	0	0	0	0	0	0	0	0	0	0	0	0	0	0

Bit/Field	Name	Type	Reset	Description
31:7	reserved	RO	0x0000.00	Software should not rely on the value of a reserved bit. To provide compatibility with future products, the value of a reserved bit should be preserved across a read-modify-write operation.
6:0	OAR	RW	0x00	I ² C Slave Own Address This field specifies bits A6 through A0 of the slave address.

Register 15: I²C Slave Control/Status (I2CCSR), offset 0x804

This register functions as a control register when written, and a status register when read.

Read-Only Status Register

I2C Slave Control/Status (I2CCSR)

I2C 0 base: 0x4002.0000
 I2C 1 base: 0x4002.1000
 I2C 2 base: 0x4002.2000
 I2C 3 base: 0x4002.3000
 I2C 4 base: 0x400C.0000
 I2C 5 base: 0x400C.1000
 I2C 6 base: 0x400C.2000
 I2C 7 base: 0x400C.3000
 I2C 8 base: 0x400B.8000
 I2C 9 base: 0x400B.9000
 Offset 0x804
 Type RO, reset 0x0000.0000

	31	30	29	28	27	26	25	24	23	22	21	20	19	18	17	16
	ACTDMARX	ACTDMATX	reserved													
Type	RO	RO	RO	RO	RO	RO	RO	RO	RO	RO	RO	RO	RO	RO	RO	RO
Reset	0	0	0	0	0	0	0	0	0	0	0	0	0	0	0	0
	15	14	13	12	11	10	9	8	7	6	5	4	3	2	1	0
	reserved										QCMDRW	QCMDST	OAR2SEL	FBR	TREQ	RREQ
Type	RO	RO	RO	RO	RO	RO	RO	RO	RO	RO	RC	RC	RO	RO	RO	RO
Reset	0	0	0	0	0	0	0	0	0	0	0	0	0	0	0	0

Bit/Field	Name	Type	Reset	Description
31	ACTDMARX	RO	0	DMA RX Active Status Value Description 0 DMA RX is not active 1 DMA RX is active.
30	ACTDMATX	RO	0	DMA TX Active Status Value Description 0 DMA TX is not active 1 DMA TX is active.
29:6	reserved	RO	0x0000.000	Software should not rely on the value of a reserved bit. To provide compatibility with future products, the value of a reserved bit should be preserved across a read-modify-write operation.
5	QCMDRW	RC	0	Quick Command Read / Write Value Description 0 Quick command was a write 1 Quick command was a read

This bit only has meaning when the QCMDST bit is set.

Bit/Field	Name	Type	Reset	Description
4	QCMDST	RC	0	Quick Command Status Value Description 0 The last transaction was a normal transaction or a transaction has not occurred. 1 The last transaction was a Quick Command transaction.
3	OAR2SEL	RO	0	OAR2 Address Matched Value Description 0 Either the address is not matched or the match is in legacy mode. 1 OAR2 address matched and ACKed by the slave. This bit gets reevaluated after every address comparison.
2	FBR	RO	0	First Byte Received Value Description 0 The first byte has not been received. 1 The first byte following the slave's own address has been received. This bit is only valid when the RREQ bit is set and is automatically cleared when data has been read from the I2CSDR register. Note: This bit is not used for slave transmit operations.
1	TREQ	RO	0	Transmit Request Value Description 0 No outstanding transmit request. 1 The I ² C controller has been addressed as a slave transmitter and is using clock stretching to delay the master until data has been written to the I2CSDR register.
0	RREQ	RO	0	Receive Request Value Description 0 No outstanding receive data. 1 The I ² C controller has outstanding receive data from the I ² C master and is using clock stretching to delay the master until the data has been read from the I2CSDR register.

Write-Only Control Register

I2C Slave Control/Status (I2CSCSR)

I2C 0 base: 0x4002.0000
 I2C 1 base: 0x4002.1000
 I2C 2 base: 0x4002.2000
 I2C 3 base: 0x4002.3000
 I2C 4 base: 0x400C.0000
 I2C 5 base: 0x400C.1000
 I2C 6 base: 0x400C.2000
 I2C 7 base: 0x400C.3000
 I2C 8 base: 0x400B.8000
 I2C 9 base: 0x400B.9000
 Offset 0x804
 Type WO, reset 0x0000.0000

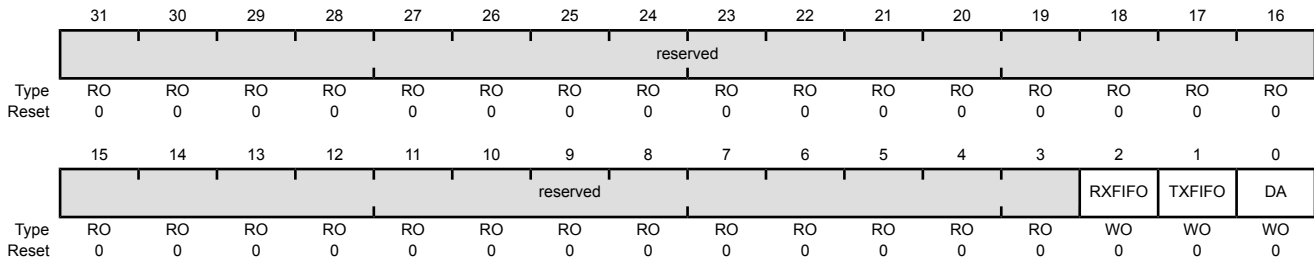

Bit/Field	Name	Type	Reset	Description
31:3	reserved	RO	0	Software should not rely on the value of a reserved bit. To provide compatibility with future products, the value of a reserved bit should be preserved across a read-modify-write operation.
2	RXFIFO	WO	0	RX FIFO Enable Value Description 0 Disables RX FIFO 1 Enables RX FIFO
1	TXFIFO	WO	0	TX FIFO Enable Value Description 0 Disables TX FIFO 1 Enables TX FIFO
0	DA	WO	0	Device Active Value Description 0 Disables the I ² C slave operation. 1 Enables the I ² C slave operation. Once this bit has been set, it should not be set again unless it has been cleared by writing a 0 or by a reset, otherwise transfer failures may occur.

Register 16: I²C Slave Data (I2CSDR), offset 0x808

Important: This register is read-sensitive. See the register description for details.

This register contains the data to be transmitted when in the Slave Transmit state, and the data received when in the Slave Receive state. If the `RXFIFO` bit or `TXFIFO` bit are enabled in the **I2CCSR** register, then this register is ignored and the data value being transferred from the FIFO is contained in the **I2CFIFODATA** register.

Note: Best practice recommends that an application should not switch between the **I2CSDR** register and TX FIFO or vice versa for successive transactions.

I2C Slave Data (I2CSDR)

I2C 0 base: 0x4002.0000
 I2C 1 base: 0x4002.1000
 I2C 2 base: 0x4002.2000
 I2C 3 base: 0x4002.3000
 I2C 4 base: 0x400C.0000
 I2C 5 base: 0x400C.1000
 I2C 6 base: 0x400C.2000
 I2C 7 base: 0x400C.3000
 I2C 8 base: 0x400B.8000
 I2C 9 base: 0x400B.9000
 Offset 0x808
 Type RW, reset 0x0000.0000

	31	30	29	28	27	26	25	24	23	22	21	20	19	18	17	16
	reserved															
Type	RO	RO	RO	RO	RO	RO	RO	RO	RO	RO	RO	RO	RO	RO	RO	RO
Reset	0	0	0	0	0	0	0	0	0	0	0	0	0	0	0	0
	15	14	13	12	11	10	9	8	7	6	5	4	3	2	1	0
	reserved								DATA							
Type	RO	RO	RO	RO	RO	RO	RO	RO	RW	RW	RW	RW	RW	RW	RW	RW
Reset	0	0	0	0	0	0	0	0	0	0	0	0	0	0	0	0

Bit/Field	Name	Type	Reset	Description
31:8	reserved	RO	0x0000.00	Software should not rely on the value of a reserved bit. To provide compatibility with future products, the value of a reserved bit should be preserved across a read-modify-write operation.
7:0	DATA	RW	0x00	Data for Transfer This field contains the data for transfer during a slave receive or transmit operation.

Register 17: I²C Slave Interrupt Mask (I2CSIMR), offset 0x80C

This register controls whether a raw interrupt is promoted to a controller interrupt.

I2C Slave Interrupt Mask (I2CSIMR)

I2C 0 base: 0x4002.0000
 I2C 1 base: 0x4002.1000
 I2C 2 base: 0x4002.2000
 I2C 3 base: 0x4002.3000
 I2C 4 base: 0x400C.0000
 I2C 5 base: 0x400C.1000
 I2C 6 base: 0x400C.2000
 I2C 7 base: 0x400C.3000
 I2C 8 base: 0x400B.8000
 I2C 9 base: 0x400B.9000
 Offset 0x80C
 Type RW, reset 0x0000.0000

	31	30	29	28	27	26	25	24	23	22	21	20	19	18	17	16
	reserved															
Type	RO	RO	RO	RO	RO	RO	RO	RO	RO	RO	RO	RO	RO	RO	RO	RO
Reset	0	0	0	0	0	0	0	0	0	0	0	0	0	0	0	0
	15	14	13	12	11	10	9	8	7	6	5	4	3	2	1	0
	reserved							RXFFIM	TXFEIM	RXIM	TXIM	DMATXIM	DMARXIM	STOPIM	STARTIM	DATAIM
Type	RO	RO	RO	RO	RO	RO	RO	RW	RW	RW	RW	RW	RW	RW	RW	RW
Reset	0	0	0	0	0	0	0	0	0	0	0	0	0	0	0	0

Bit/Field	Name	Type	Reset	Description
31:9	reserved	RO	0	Software should not rely on the value of a reserved bit. To provide compatibility with future products, the value of a reserved bit should be preserved across a read-modify-write operation.
8	RXFFIM	RW	0	Receive FIFO Full Interrupt Mask Value Description 0 The <code>RXFFRIS</code> interrupt is suppressed and not sent to the interrupt controller. 1 The Receive FIFO Full interrupt is sent to the interrupt controller when the <code>RXFFRIS</code> bit in the I2CSRIS register is set.
7	TXFEIM	RW	0	Transmit FIFO Empty Interrupt Mask Value Description 0 The <code>TXFERIS</code> interrupt is suppressed and not sent to the interrupt controller. 1 The Transmit FIFO Empty interrupt is sent to the interrupt controller when the <code>TXFERIS</code> bit in the I2CSRIS register is set.
6	RXIM	RW	0	Receive FIFO Request Interrupt Mask Value Description 0 The <code>RXRIS</code> interrupt is suppressed and not sent to the interrupt controller. 1 The RX FIFO Request interrupt is sent to the interrupt controller when the <code>RXRIS</code> bit in the I2CSRIS register is set.

Bit/Field	Name	Type	Reset	Description
5	TXIM	RW	0	Transmit FIFO Request Interrupt Mask Value Description 0 The TXRIS interrupt is suppressed and not sent to the interrupt controller. 1 The TX FIFO Request interrupt is sent to the interrupt controller when the TXRIS bit in the I2CSRIS register is set.
4	DMATXIM	RW	0	Transmit DMA Interrupt Mask Value Description 0 The DMATXRIS interrupt is suppressed and not sent to the interrupt controller. 1 The transmit DMA complete interrupt is sent to the interrupt controller when the DMATXRIS bit in the I2CSRIS register is set.
3	DMARXIM	RW	0	Receive DMA Interrupt Mask Value Description 0 The DMARXRIS interrupt is suppressed and not sent to the interrupt controller. 1 The receive DMA complete interrupt is sent to the interrupt controller when the DMARXRIS bit in the I2CSRIS register is set.
2	STOPIIM	RW	0	Stop Condition Interrupt Mask Value Description 0 The STOPRIS interrupt is suppressed and not sent to the interrupt controller. 1 The STOP condition interrupt is sent to the interrupt controller when the STOPRIS bit in the I2CSRIS register is set.
1	STARTIM	RW	0	Start Condition Interrupt Mask Value Description 0 The STARTRIS interrupt is suppressed and not sent to the interrupt controller. 1 The START condition interrupt is sent to the interrupt controller when the STARTRIS bit in the I2CSRIS register is set.
0	DATAIM	RW	0	Data Interrupt Mask Value Description 0 The DATARIS interrupt is suppressed and not sent to the interrupt controller. 1 Data interrupt sent to interrupt controller when DATARIS bit in the I2CSRIS register is set.

Register 18: I²C Slave Raw Interrupt Status (I2CSRIS), offset 0x810

This register specifies whether an interrupt is pending.

I2C Slave Raw Interrupt Status (I2CSRIS)

I2C 0 base: 0x4002.0000
 I2C 1 base: 0x4002.1000
 I2C 2 base: 0x4002.2000
 I2C 3 base: 0x4002.3000
 I2C 4 base: 0x400C.0000
 I2C 5 base: 0x400C.1000
 I2C 6 base: 0x400C.2000
 I2C 7 base: 0x400C.3000
 I2C 8 base: 0x400B.8000
 I2C 9 base: 0x400B.9000
 Offset 0x810
 Type RO, reset 0x0000.0000

	31	30	29	28	27	26	25	24	23	22	21	20	19	18	17	16
	reserved															
Type	RO	RO	RO	RO	RO	RO	RO	RO	RO	RO	RO	RO	RO	RO	RO	RO
Reset	0	0	0	0	0	0	0	0	0	0	0	0	0	0	0	0
	15	14	13	12	11	10	9	8	7	6	5	4	3	2	1	0
	reserved							RXFFRIS	TXFERIS	RXRIS	TXRIS	DMATXRIS	DMARXRIS	STOPRIS	STARTRIS	DATARIS
Type	RO	RO	RO	RO	RO	RO	RO	RO	RO	RO	RO	RO	RO	RO	RO	RO
Reset	0	0	0	0	0	0	0	0	0	0	0	0	0	0	0	0

Bit/Field	Name	Type	Reset	Description
31:9	reserved	RO	0	Software should not rely on the value of a reserved bit. To provide compatibility with future products, the value of a reserved bit should be preserved across a read-modify-write operation.
8	RXFFRIS	RO	0	<p>Receive FIFO Full Raw Interrupt Status</p> <p>Value Description</p> <p>0 No interrupt</p> <p>1 The Receive FIFO Full interrupt is pending.</p> <p>This bit is cleared by writing a 1 to the <code>RXFFIC</code> bit in the <code>I2CSICR</code> register.</p>
7	TXFERIS	RO	0	<p>Transmit FIFO Empty Raw Interrupt Status</p> <p>Value Description</p> <p>0 No interrupt</p> <p>1 The Transmit FIFO Empty interrupt is pending.</p> <p>This bit is cleared by writing a 1 to the <code>TXFEIC</code> bit in the <code>I2CSICR</code> register.</p> <p>Note that if the <code>TXFERIS</code> interrupt is cleared (by setting the <code>TXFEIC</code> bit) when the TX FIFO is empty, the <code>TXFERIS</code> interrupt does not reassert even though the TX FIFO remains empty in this situation.</p>

Bit/Field	Name	Type	Reset	Description
6	RXRIS	RO	0	<p>Receive FIFO Request Raw Interrupt Status</p> <p>Value Description</p> <p>0 No interrupt</p> <p>1 The trigger value for the FIFO has been reached and a RX FIFO Request interrupt is pending.</p> <p>This bit is cleared by writing a 1 to the <code>RXIC</code> bit in the I2CSICR register.</p>
5	TXRIS	RO	0	<p>Transmit Request Raw Interrupt Status</p> <p>Value Description</p> <p>0 No interrupt</p> <p>1 The trigger value for the FIFO has been reached and a TX FIFO Request interrupt is pending.</p> <p>This bit is cleared by writing a 1 to the <code>TXIC</code> bit in the I2CSICR register.</p>
4	DMATXRIS	RO	0	<p>Transmit DMA Raw Interrupt Status</p> <p>Value Description</p> <p>0 No interrupt.</p> <p>1 A transmit DMA complete interrupt is pending.</p> <p>This bit is cleared by writing a 1 to the <code>DMATXIC</code> bit in the I2CSICR register.</p>
3	DMARXRIS	RO	0	<p>Receive DMA Raw Interrupt Status</p> <p>Value Description</p> <p>0 No interrupt.</p> <p>1 A receive DMA complete interrupt is pending.</p> <p>This bit is cleared by writing a 1 to the <code>DMARXIC</code> bit in the I2CSICR register.</p>
2	STOPRIS	RO	0	<p>Stop Condition Raw Interrupt Status</p> <p>Value Description</p> <p>0 No interrupt.</p> <p>1 A STOP condition interrupt is pending.</p> <p>This bit is cleared by writing a 1 to the <code>STOPIC</code> bit in the I2CSICR register.</p>
1	STARTRIS	RO	0	<p>Start Condition Raw Interrupt Status</p> <p>Value Description</p> <p>0 No interrupt.</p> <p>1 A START condition interrupt is pending.</p> <p>This bit is cleared by writing a 1 to the <code>STARTIC</code> bit in the I2CSICR register.</p>

Bit/Field	Name	Type	Reset	Description				
0	DATARIS	RO	0	<p>Data Raw Interrupt Status</p> <p>This interrupt encompasses the following:</p> <ul style="list-style-type: none">■ Slave transaction received■ Slave transaction requested■ Next byte transfer request <p>Value Description</p> <table><tbody><tr><td>0</td><td>No interrupt.</td></tr><tr><td>1</td><td>Slave Interrupt is pending.</td></tr></tbody></table> <p>This bit is cleared by writing a 1 to the <code>DATAIC</code> bit in the <code>I2CSICR</code> register.</p>	0	No interrupt.	1	Slave Interrupt is pending.
0	No interrupt.							
1	Slave Interrupt is pending.							

Register 19: I²C Slave Masked Interrupt Status (I2CSMIS), offset 0x814

This register specifies whether an interrupt was signaled.

I2C Slave Masked Interrupt Status (I2CSMIS)

I2C 0 base: 0x4002.0000
 I2C 1 base: 0x4002.1000
 I2C 2 base: 0x4002.2000
 I2C 3 base: 0x4002.3000
 I2C 4 base: 0x400C.0000
 I2C 5 base: 0x400C.1000
 I2C 6 base: 0x400C.2000
 I2C 7 base: 0x400C.3000
 I2C 8 base: 0x400B.8000
 I2C 9 base: 0x400B.9000
 Offset 0x814
 Type RO, reset 0x0000.0000

	31	30	29	28	27	26	25	24	23	22	21	20	19	18	17	16
	reserved															
Type	RO	RO	RO	RO	RO	RO	RO	RO	RO	RO	RO	RO	RO	RO	RO	RO
Reset	0	0	0	0	0	0	0	0	0	0	0	0	0	0	0	0
	15	14	13	12	11	10	9	8	7	6	5	4	3	2	1	0
	reserved							RXFFMIS	TXFEMIS	RXMIS	TXMIS	DMATXMIS	DMARXMIS	STOPMIS	STARTMIS	DATAMIS
Type	RO	RO	RO	RO	RO	RO	RO	RO	RO	RO	RO	RO	RO	RO	RO	RO
Reset	0	0	0	0	0	0	0	0	0	0	0	0	0	0	0	0

Bit/Field	Name	Type	Reset	Description
31:9	reserved	RO	0	Software should not rely on the value of a reserved bit. To provide compatibility with future products, the value of a reserved bit should be preserved across a read-modify-write operation.
8	RXFFMIS	RO	0	Receive FIFO Full Interrupt Mask Value Description 0 No interrupt. 1 An unmasked Receive FIFO Full interrupt was signaled and is pending. This bit is cleared by writing a 1 to the RXFFIC bit in the I2CSICR register.
7	TXFEMIS	RO	0	Transmit FIFO Empty Interrupt Mask Value Description 0 No interrupt. 1 An unmasked Transmit FIFO Empty interrupt was signaled and is pending. This bit is cleared by writing a 1 to the TXFEIC bit in the I2CSICR register.

Bit/Field	Name	Type	Reset	Description
6	RXMIS	RO	0	<p>Receive FIFO Request Interrupt Mask</p> <p>Value Description</p> <p>0 No interrupt.</p> <p>1 An unmasked Receive FIFO Request interrupt was signaled and is pending.</p> <p>This bit is cleared by writing a 1 to the <code>RXIC</code> bit in the I2CSICR register.</p>
5	TXMIS	RO	0	<p>Transmit FIFO Request Interrupt Mask</p> <p>Value Description</p> <p>0 No interrupt.</p> <p>1 An unmasked Transmit FIFO Request interrupt was signaled and is pending.</p> <p>This bit is cleared by writing a 1 to the <code>TXIC</code> bit in the I2CSICR register.</p>
4	DMATXMIS	RO	0	<p>Transmit DMA Masked Interrupt Status</p> <p>Value Description</p> <p>0 An interrupt has not occurred or is masked.</p> <p>1 An unmasked transmit DMA complete interrupt was signaled is pending.</p> <p>This bit is cleared by writing a 1 to the <code>DMATXIC</code> bit in the I2CSICR register.</p>
3	DMARXMIS	RO	0	<p>Receive DMA Masked Interrupt Status</p> <p>Value Description</p> <p>0 An interrupt has not occurred or is masked.</p> <p>1 An unmasked receive DMA complete interrupt was signaled is pending.</p> <p>This bit is cleared by writing a 1 to the <code>DMARXIC</code> bit in the I2CSICR register.</p>
2	STOPMIS	RO	0	<p>Stop Condition Masked Interrupt Status</p> <p>Value Description</p> <p>0 An interrupt has not occurred or is masked.</p> <p>1 An unmasked STOP condition interrupt was signaled is pending.</p> <p>This bit is cleared by writing a 1 to the <code>STOPIC</code> bit in the I2CSICR register.</p>

Bit/Field	Name	Type	Reset	Description
1	STARTMIS	RO	0	<p>Start Condition Masked Interrupt Status</p> <p>Value Description</p> <p>0 An interrupt has not occurred or is masked.</p> <p>1 An unmasked START condition interrupt was signaled is pending.</p> <p>This bit is cleared by writing a 1 to the <code>STARTIC</code> bit in the I2CSICR register.</p>
0	DATAMIS	RO	0	<p>Data Masked Interrupt Status</p> <p>Value Description</p> <p>0 An interrupt has not occurred or is masked.</p> <p>1 An unmasked slave data interrupt was signaled is pending.</p> <p>This bit is cleared by writing a 1 to the <code>DATAIC</code> bit in the I2CSICR register.</p>

Register 20: I²C Slave Interrupt Clear (I2CSICR), offset 0x818

This register clears the raw interrupt. A read of this register returns no meaningful data.

I2C Slave Interrupt Clear (I2CSICR)

I2C 0 base: 0x4002.0000
 I2C 1 base: 0x4002.1000
 I2C 2 base: 0x4002.2000
 I2C 3 base: 0x4002.3000
 I2C 4 base: 0x400C.0000
 I2C 5 base: 0x400C.1000
 I2C 6 base: 0x400C.2000
 I2C 7 base: 0x400C.3000
 I2C 8 base: 0x400B.8000
 I2C 9 base: 0x400B.9000
 Offset 0x818
 Type WO, reset 0x0000.0000

	31	30	29	28	27	26	25	24	23	22	21	20	19	18	17	16
	reserved															
Type	RO	RO	RO	RO	RO	RO	RO	RO	RO	RO	RO	RO	RO	RO	RO	RO
Reset	0	0	0	0	0	0	0	0	0	0	0	0	0	0	0	0
	15	14	13	12	11	10	9	8	7	6	5	4	3	2	1	0
	reserved							RXFFIC	TXFEIC	RXIC	TXIC	DMATXIC	DMARXIC	STOPIC	STARTIC	DATAIC
Type	RO	RO	RO	RO	RO	RO	RO	WO	WO	WO	WO	WO	WO	WO	WO	WO
Reset	0	0	0	0	0	0	0	0	0	0	0	0	0	0	0	0

Bit/Field	Name	Type	Reset	Description
31:9	reserved	RO	0	Software should not rely on the value of a reserved bit. To provide compatibility with future products, the value of a reserved bit should be preserved across a read-modify-write operation.
8	RXFFIC	WO	0	Receive FIFO Full Interrupt Mask Writing a 1 to this bit clears the RXFFIS bit in the I2CSRIS register and the RXFFMIS bit in the I2CSMIS register. A read of this register returns no meaningful data.
7	TXFEIC	WO	0	Transmit FIFO Empty Interrupt Mask Writing a 1 to this bit clears the TXFERIS bit in the I2CSRIS register and the TXFEMIS bit in the I2CSMIS register. A read of this register returns no meaningful data.
6	RXIC	WO	0	Receive Request Interrupt Mask Writing a 1 to this bit clears the RXRIS bit in the I2CSRIS register and the RXMIS bit in the I2CSMIS register. A read of this register returns no meaningful data.
5	TXIC	WO	0	Transmit Request Interrupt Mask Writing a 1 to this bit clears the TXRIS bit in the I2CSRIS register and the TXMIS bit in the I2CSMIS register. A read of this register returns no meaningful data.
4	DMATXIC	WO	0	Transmit DMA Interrupt Clear Writing a 1 to this bit clears the DMATXRIS bit in the I2CSRIS register and the DMATXMIS bit in the I2CSMIS register. A read of this register returns no meaningful data.

Bit/Field	Name	Type	Reset	Description
3	DMARXIC	WO	0	Receive DMA Interrupt Clear Writing a 1 to this bit clears the <code>DMARXRIS</code> bit in the I2CSRIS register and the <code>DMARXMIS</code> bit in the I2CSMIS register. A read of this register returns no meaningful data.
2	STOPIC	WO	0	Stop Condition Interrupt Clear Writing a 1 to this bit clears the <code>STOPRIS</code> bit in the I2CSRIS register and the <code>STOPMIS</code> bit in the I2CSMIS register. A read of this register returns no meaningful data.
1	STARTIC	WO	0	Start Condition Interrupt Clear Writing a 1 to this bit clears the <code>STARTRIS</code> bit in the I2CSRIS register and the <code>STARTMIS</code> bit in the I2CSMIS register. A read of this register returns no meaningful data.
0	DATAIC	WO	0	Data Interrupt Clear Writing a 1 to this bit clears the <code>DATARIS</code> bit in the I2CSRIS register and the <code>DATMIS</code> bit in the I2CSMIS register. A read of this register returns no meaningful data.

Register 21: I²C Slave Own Address 2 (I2CSOAR2), offset 0x81C

This register consists of seven address bits that identify the alternate address for the I²C device on the I²C bus.

I2C Slave Own Address 2 (I2CSOAR2)

I2C 0 base: 0x4002.0000
 I2C 1 base: 0x4002.1000
 I2C 2 base: 0x4002.2000
 I2C 3 base: 0x4002.3000
 I2C 4 base: 0x400C.0000
 I2C 5 base: 0x400C.1000
 I2C 6 base: 0x400C.2000
 I2C 7 base: 0x400C.3000
 I2C 8 base: 0x400B.8000
 I2C 9 base: 0x400B.9000
 Offset 0x81C
 Type RW, reset 0x0000.0000

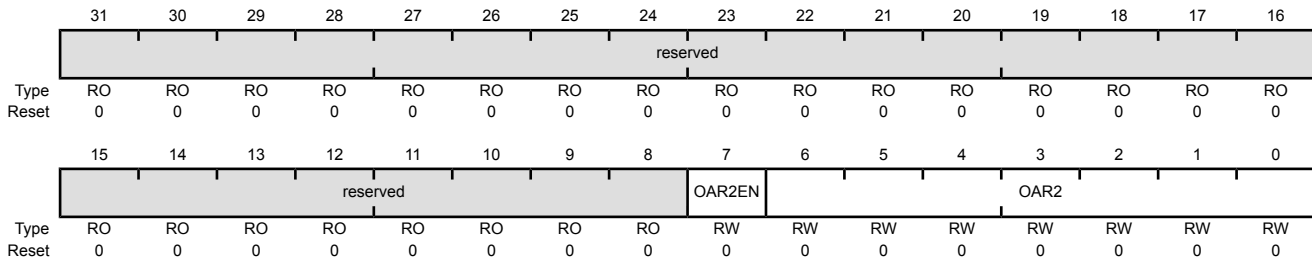

Bit/Field	Name	Type	Reset	Description
31:8	reserved	RO	0x0000.00	Software should not rely on the value of a reserved bit. To provide compatibility with future products, the value of a reserved bit should be preserved across a read-modify-write operation.
7	OAR2EN	RW	0	I ² C Slave Own Address 2 Enable Value Description 0 The alternate address is disabled. 1 Enables the use of the alternate address in the OAR2 field.
6:0	OAR2	RW	0x00	I ² C Slave Own Address 2 This field specifies the alternate OAR2 address.

Register 22: I²C Slave ACK Control (I2CSACKCTL), offset 0x820

This register enables the I²C slave to NACK for invalid data or command or ACK for valid data or command. The I²C clock is pulled low after the last data bit until this register is written.

I²C Slave ACK Control (I2CSACKCTL)

I2C 0 base: 0x4002.0000
 I2C 1 base: 0x4002.1000
 I2C 2 base: 0x4002.2000
 I2C 3 base: 0x4002.3000
 I2C 4 base: 0x400C.0000
 I2C 5 base: 0x400C.1000
 I2C 6 base: 0x400C.2000
 I2C 7 base: 0x400C.3000
 I2C 8 base: 0x400B.8000
 I2C 9 base: 0x400B.9000
 Offset 0x820
 Type RW, reset 0x0000.0000

	31	30	29	28	27	26	25	24	23	22	21	20	19	18	17	16	
	reserved																
Type	RO	RO	RO	RO	RO	RO	RO	RO	RO	RO	RO	RO	RO	RO	RO	RO	
Reset	0	0	0	0	0	0	0	0	0	0	0	0	0	0	0	0	
	15	14	13	12	11	10	9	8	7	6	5	4	3	2	1	0	
	reserved															ACKOVAL	ACKOEN
Type	RO	RO	RO	RO	RO	RO	RO	RO	RO	RO	RO	RO	RO	RO	RO	RW	RW
Reset	0	0	0	0	0	0	0	0	0	0	0	0	0	0	0	0	0

Bit/Field	Name	Type	Reset	Description
31:2	reserved	RO	0x0000.000	Software should not rely on the value of a reserved bit. To provide compatibility with future products, the value of a reserved bit should be preserved across a read-modify-write operation.
1	ACKOVAL	RW	0	I ² C Slave ACK Override Value Value Description 0 An ACK is sent indicating valid data or command. 1 A NACK is sent indicating invalid data or command.
0	ACKOEN	RW	0	I ² C Slave ACK Override Enable Value Description 0 A response is not provided. 1 An ACK or NACK is sent according to the value written to the ACKOVAL bit.

21.8 Register Descriptions (I²C Status and Control)

The remainder of this section lists and describes the I²C status and control registers, in numerical order by address offset.

Register 23: I²C FIFO Data (I2CFIFODATA), offset 0xF00

The I²C FIFO Data (I2CFIFODATA) register contains the current value of the top of the RX or TX FIFO stack being used in the a transfer.

Read-Only Status Register

I2C FIFO Data (I2CFIFODATA)

I2C 0 base: 0x4002.0000
 I2C 1 base: 0x4002.1000
 I2C 2 base: 0x4002.2000
 I2C 3 base: 0x4002.3000
 I2C 4 base: 0x400C.0000
 I2C 5 base: 0x400C.1000
 I2C 6 base: 0x400C.2000
 I2C 7 base: 0x400C.3000
 I2C 8 base: 0x400B.8000
 I2C 9 base: 0x400B.9000
 Offset 0xF00
 Type RO, reset 0x0000.0000

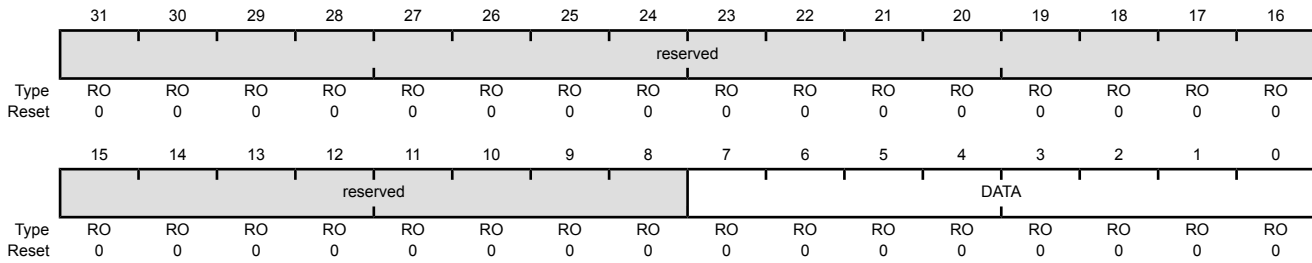

Bit/Field	Name	Type	Reset	Description
31:8	reserved	RO	0x0000.00	Software should not rely on the value of a reserved bit. To provide compatibility with future products, the value of a reserved bit should be preserved across a read-modify-write operation.
7:0	DATA	RO	0	I ² C RX FIFO Read Data Byte This field contains the current byte being read in the RX FIFO stack.

Write-Only Control Register

I2C FIFO Data (I2CFIFODATA)

I2C 0 base: 0x4002.0000
 I2C 1 base: 0x4002.1000
 I2C 2 base: 0x4002.2000
 I2C 3 base: 0x4002.3000
 I2C 4 base: 0x400C.0000
 I2C 5 base: 0x400C.1000
 I2C 6 base: 0x400C.2000
 I2C 7 base: 0x400C.3000
 I2C 8 base: 0x400B.8000
 I2C 9 base: 0x400B.9000
 Offset 0xF00
 Type WO, reset 0x0000.0000

	31	30	29	28	27	26	25	24	23	22	21	20	19	18	17	16
	reserved															
Type	RO	RO	RO	RO	RO	RO	RO	RO	RO	RO	RO	RO	RO	RO	RO	RO
Reset	0	0	0	0	0	0	0	0	0	0	0	0	0	0	0	0
	15	14	13	12	11	10	9	8	7	6	5	4	3	2	1	0
	reserved								DATA							
Type	RO	RO	RO	RO	RO	RO	RO	RO	WO	WO	WO	WO	WO	WO	WO	WO
Reset	0	0	0	0	0	0	0	0	0	0	0	0	0	0	0	0

Bit/Field	Name	Type	Reset	Description
31:8	reserved	RO	0x0000.00	Software should not rely on the value of a reserved bit. To provide compatibility with future products, the value of a reserved bit should be preserved across a read-modify-write operation.
7:0	DATA	WO	0	I ² C TX FIFO Write Data Byte This field contains the current byte written to the TX FIFO. For back to back transmit operations, the application should not switch between writing to the I2CSDR register and the I2CFIFODATA .

Register 24: I²C FIFO Control (I2CFIFOCTL), offset 0xF04

The FIFO Control Register can be programmed to control various aspects of the FIFO transaction, such as RX and TX FIFO assignment, byte count value for FIFO triggers and flushing of the FIFOs.

I2C FIFO Control (I2CFIFOCTL)

I2C 0 base: 0x4002.0000
 I2C 1 base: 0x4002.1000
 I2C 2 base: 0x4002.2000
 I2C 3 base: 0x4002.3000
 I2C 4 base: 0x400C.0000
 I2C 5 base: 0x400C.1000
 I2C 6 base: 0x400C.2000
 I2C 7 base: 0x400C.3000
 I2C 8 base: 0x400B.8000
 I2C 9 base: 0x400B.9000
 Offset 0xF04
 Type RW, reset 0x0004.0004

	31	30	29	28	27	26	25	24	23	22	21	20	19	18	17	16	
	RXASGNMT	RXFLUSH	DMARXENA	reserved										RXTRIG			
Type	RW	RW	RW	RO	RO	RO	RO	RO	RO	RO	RO	RO	RO	RO	RW	RW	RW
Reset	0	0	0	0	0	0	0	0	0	0	0	0	0	0	1	0	0
	15	14	13	12	11	10	9	8	7	6	5	4	3	2	1	0	
	TXASGNMT	TXFLUSH	DMATXENA	reserved										TXTRIG			
Type	RW	RW	RW	RO	RO	RO	RO	RO	RO	RO	RO	RO	RO	RO	RW	RW	RW
Reset	0	0	0	0	0	0	0	0	0	0	0	0	0	0	1	0	0

Bit/Field	Name	Type	Reset	Description
31	RXASGNMT	RW	0	RX Control Assignment Value Description 0 RX FIFO is assigned to Master 1 RX FIFO is assigned to Slave
30	RXFLUSH	RW	0	RX FIFO Flush Setting this bit will Flush the RX FIFO. This bit will self-clear when the flush has completed.
29	DMARXENA	RW	0	DMA RX Channel Enable Value Description 0 DMA RX channel disabled 1 DMA RX channel enabled
28:19	reserved	RO	0x00	Software should not rely on the value of a reserved bit. To provide compatibility with future products, the value of a reserved bit should be preserved across a read-modify-write operation.

Bit/Field	Name	Type	Reset	Description
18:16	RXTRIG	RW	0x4	<p>RX FIFO Trigger</p> <p>Indicates at what fill level the RX FIFO will generate a trigger.</p> <p>Note: Programming RXTRIG to 0x0 has no effect since no data is present to transfer out of RX FIFO.</p> <p>Value Description</p> <p>0x0 Trigger when RX FIFO contains no bytes</p> <p>0x1 Trigger when Rx FIFO contains 1 or more bytes</p> <p>0x2 Trigger when Rx FIFO contains 2 or more bytes</p> <p>0x3 Trigger when Rx FIFO contains 3 or more bytes</p> <p>0x4 Trigger when Rx FIFO contains 4 or more bytes</p> <p>0x5 Trigger when Rx FIFO contains 5 or more bytes</p> <p>0x6 Trigger when Rx FIFO contains 6 or more bytes</p> <p>0x7 Trigger when Rx FIFO contains 7 or more bytes.</p>
15	TXASGNMT	RW	0	<p>TX Control Assignment</p> <p>Value Description</p> <p>0 TX FIFO is assigned to Master</p> <p>1 TX FIFO is assigned to Slave</p>
14	TXFLUSH	RW	0	<p>TX FIFO Flush</p> <p>Setting this bit will Flush the TX FIFO. This bit will self-clear when the flush has completed.</p>
13	DMATXENA	RW	0	<p>DMA TX Channel Enable</p> <p>Value Description</p> <p>0 DMA TX channel disabled</p> <p>1 DMA TX channel enabled</p>
12:3	reserved	RO	0x000	<p>Software should not rely on the value of a reserved bit. To provide compatibility with future products, the value of a reserved bit should be preserved across a read-modify-write operation.</p>
2:0	TXTRIG	RW	0x4	<p>TX FIFO Trigger</p> <p>Indicates at what fill level in the TX FIFO a trigger will be generated.</p> <p>Value Description</p> <p>0x0 Trigger when the TX FIFO is empty.</p> <p>0x1 Trigger when TX FIFO contains ≤ 1 byte</p> <p>0x2 Trigger when TX FIFO contains ≤ 2 bytes</p> <p>0x3 Trigger when TX FIFO ≤ 3 bytes</p> <p>0x4 Trigger when FIFO ≤ 4 bytes</p> <p>0x5 Trigger when FIFO ≤ 5 bytes</p> <p>0x6 Trigger when FIFO ≤ 6 bytes</p> <p>0x7 Trigger when FIFO ≤ 7 bytes</p>

Register 25: I²C FIFO Status (I2CFIFOSTATUS), offset 0xF08

This register contains the real-time status of the RX and TX FIFOs.

I2C FIFO Status (I2CFIFOSTATUS)

I2C 0 base: 0x4002.0000
 I2C 1 base: 0x4002.1000
 I2C 2 base: 0x4002.2000
 I2C 3 base: 0x4002.3000
 I2C 4 base: 0x400C.0000
 I2C 5 base: 0x400C.1000
 I2C 6 base: 0x400C.2000
 I2C 7 base: 0x400C.3000
 I2C 8 base: 0x400B.8000
 I2C 9 base: 0x400B.9000
 Offset 0xF08
 Type RO, reset 0x0001.0005

	31	30	29	28	27	26	25	24	23	22	21	20	19	18	17	16
	reserved													RXABVTRIG	RXFF	RXFE
Type	RO	RO	RO	RO	RO	RO	RO	RO	RO	RO	RO	RO	RO	RO	RO	RO
Reset	0	0	0	0	0	0	0	0	0	0	0	0	0	0	0	1
	15	14	13	12	11	10	9	8	7	6	5	4	3	2	1	0
	reserved													TXBLWTRIG	TXFF	TXFE
Type	RO	RO	RO	RO	RO	RO	RO	RO	RO	RO	RO	RO	RO	RO	RO	RO
Reset	0	0	0	0	0	0	0	0	0	0	0	0	0	1	0	1

Bit/Field	Name	Type	Reset	Description
31:19	reserved	RO	0x000	Software should not rely on the value of a reserved bit. To provide compatibility with future products, the value of a reserved bit should be preserved across a read-modify-write operation.
18	RXABVTRIG	RO	0	RX FIFO Above Trigger Level Value Description 0 The number of bytes in RX FIFO is below the trigger level programmed by the <i>RXTRIG</i> bit in the <i>I2CFIFOCTL</i> register 1 The number of bytes in the RX FIFO is above the trigger level programmed by the <i>RXTRIG</i> bit in the <i>I2CFIFOCTL</i> register
17	RXFF	RO	0	RX FIFO Full Value Description 0 The RX FIFO is not full. 1 The RX FIFO is full.
16	RXFE	RO	1	RX FIFO Empty Value Description 0 The RX FIFO is not empty. 1 The RX FIFO is empty.
15:3	reserved	RO	0x000	Software should not rely on the value of a reserved bit. To provide compatibility with future products, the value of a reserved bit should be preserved across a read-modify-write operation.

Bit/Field	Name	Type	Reset	Description
2	TXBLWTRIG	RO	1	TX FIFO Below Trigger Level Value Description 0 The number of bytes in TX FIFO is above the trigger level programmed by the TXTRIG bit in the I2CFIFOCTL register 1 The number of bytes in the TX FIFO is below the trigger level programmed by the TXTRIG bit in the I2CFIFOCTL register
1	TXFF	RO	0	TX FIFO Full Value Description 0 The TX FIFO is not full. 1 The TX FIFO is full.
0	TXFE	RO	1	TX FIFO Empty Value Description 0 The TX FIFO is not empty. 1 The TX FIFO is empty.

Register 26: I²C Peripheral Properties (I2CPP), offset 0xFC0

The I2CPP register provides information regarding the properties of the I²C module.

I2C Peripheral Properties (I2CPP)

I2C 0 base: 0x4002.0000
 I2C 1 base: 0x4002.1000
 I2C 2 base: 0x4002.2000
 I2C 3 base: 0x4002.3000
 I2C 4 base: 0x400C.0000
 I2C 5 base: 0x400C.1000
 I2C 6 base: 0x400C.2000
 I2C 7 base: 0x400C.3000
 I2C 8 base: 0x400B.8000
 I2C 9 base: 0x400B.9000
 Offset 0xFC0
 Type RO, reset 0x0000.0001

	31	30	29	28	27	26	25	24	23	22	21	20	19	18	17	16
	reserved															
Type	RO	RO	RO	RO	RO	RO	RO	RO	RO	RO	RO	RO	RO	RO	RO	RO
Reset	0	0	0	0	0	0	0	0	0	0	0	0	0	0	0	0
	15	14	13	12	11	10	9	8	7	6	5	4	3	2	1	0
	reserved															HS
Type	RO	RO	RO	RO	RO	RO	RO	RO	RO	RO	RO	RO	RO	RO	RO	RO
Reset	0	0	0	0	0	0	0	0	0	0	0	0	0	0	0	1

Bit/Field	Name	Type	Reset	Description
31:1	reserved	RO	0x0	Software should not rely on the value of a reserved bit. To provide compatibility with future products, the value of a reserved bit should be preserved across a read-modify-write operation.
0	HS	RO	0x1	High-Speed Capable
				Value Description
			0	The interface is capable of Standard, Fast, or Fast mode plus operation.
			1	The interface is capable of High-Speed operation.

Register 27: I²C Peripheral Configuration (I2CPC), offset 0xFC4

The **I2CPC** register allows software to enable features present in the I²C module.

I2C Peripheral Configuration (I2CPC)

I2C 0 base: 0x4002.0000
 I2C 1 base: 0x4002.1000
 I2C 2 base: 0x4002.2000
 I2C 3 base: 0x4002.3000
 I2C 4 base: 0x400C.0000
 I2C 5 base: 0x400C.1000
 I2C 6 base: 0x400C.2000
 I2C 7 base: 0x400C.3000
 I2C 8 base: 0x400B.8000
 I2C 9 base: 0x400B.9000
 Offset 0xFC4
 Type RO, reset 0x0000.0001

	31	30	29	28	27	26	25	24	23	22	21	20	19	18	17	16
	reserved															
Type	RO	RO	RO	RO	RO	RO	RO	RO	RO	RO	RO	RO	RO	RO	RO	RO
Reset	0	0	0	0	0	0	0	0	0	0	0	0	0	0	0	0
	15	14	13	12	11	10	9	8	7	6	5	4	3	2	1	0
	reserved															HS
Type	RO	RO	RO	RO	RO	RO	RO	RO	RO	RO	RO	RO	RO	RO	RO	RW
Reset	0	0	0	0	0	0	0	0	0	0	0	0	0	0	0	1

Bit/Field	Name	Type	Reset	Description
31:1	reserved	RO	0	Software should not rely on the value of a reserved bit. To provide compatibility with future products, the value of a reserved bit should be preserved across a read-modify-write operation.
0	HS	RW	1	High-Speed Capable
				Value Description
			0	The interface is set to Standard, Fast or Fast mode plus operation.
			1	The interface is set to High-Speed operation. Note that this encoding may only be used if the HS bit in the I2CPP register is set. Otherwise, this encoding is not available.

22 Controller Area Network (CAN) Module

Controller Area Network (CAN) is a multicast, shared serial bus standard for connecting electronic control units (ECUs). CAN was specifically designed to be robust in electromagnetically-noisy environments and can utilize a differential balanced line like RS-485 or a more robust twisted-pair wire. Originally created for automotive purposes, it is also used in many embedded control applications (such as industrial and medical). Bit rates up to 1 Mbps are possible at network lengths less than 40 meters. Decreased bit rates allow longer network distances (for example, 125 Kbps at 500 meters).

The TM4C129ENCPDT microcontroller includes two CAN units with the following features:

- CAN protocol version 2.0 part A/B
- Bit rates up to 1 Mbps
- 32 message objects with individual identifier masks
- Maskable interrupt
- Disable Automatic Retransmission mode for Time-Triggered CAN (TTCAN) applications
- Programmable loopback mode for self-test operation
- Programmable FIFO mode enables storage of multiple message objects
- Gluelessly attaches to an external CAN transceiver through the `CANnTX` and `CANnRX` signals

22.1 Block Diagram

Figure 22-1. CAN Controller Block Diagram

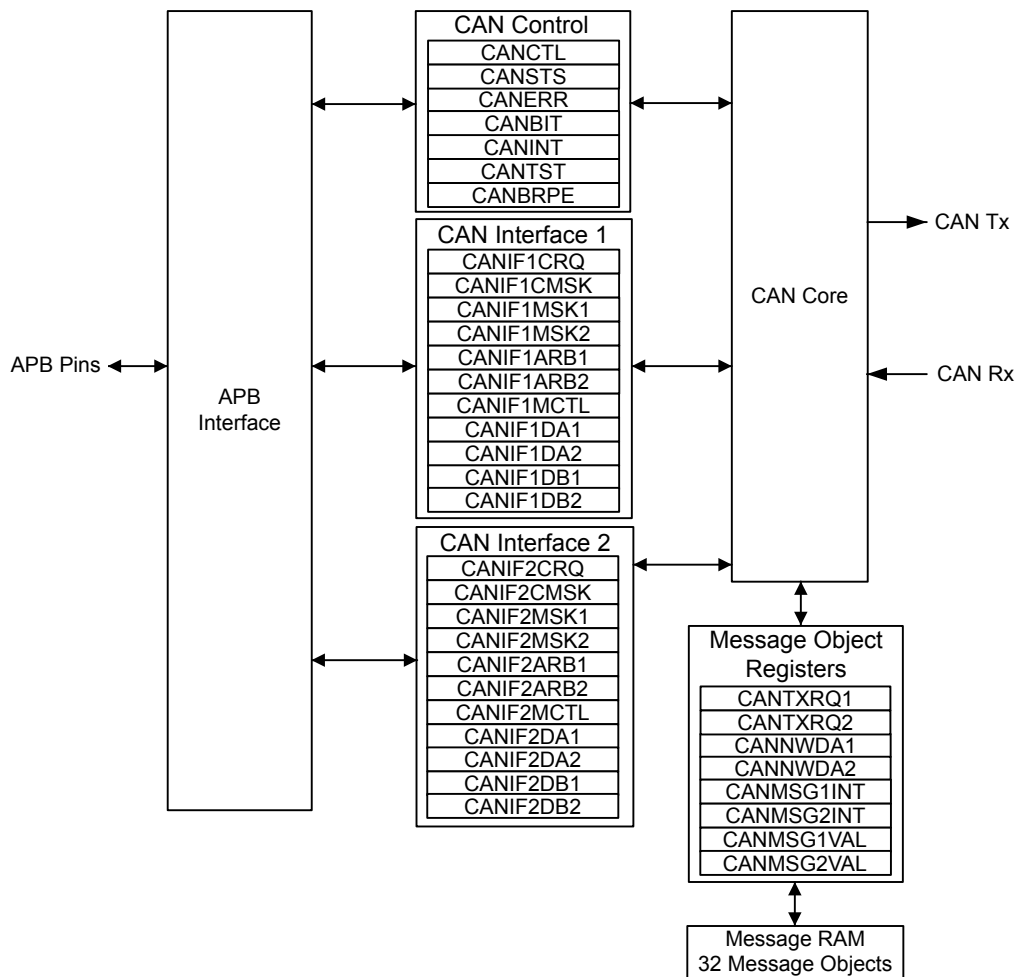

22.2 Signal Description

The following table lists the external signals of the CAN controller and describes the function of each. The CAN controller signals are alternate functions for some GPIO signals and default to be GPIO signals at reset. The column in the table below titled "Pin Mux/Pin Assignment" lists the possible GPIO pin placements for the CAN signals. The `AFSEL` bit in the **GPIO Alternate Function Select (GPIOAFSEL)** register (page 778) should be set to choose the CAN controller function. The number in parentheses is the encoding that must be programmed into the `PMCn` field in the **GPIO Port Control (GPIOCTL)** register (page 795) to assign the CAN signal to the specified GPIO port pin. For more information on configuring GPIOs, see "General-Purpose Input/Outputs (GPIOs)" on page 750.

Table 22-1. Controller Area Network Signals (128TQFP)

Pin Name	Pin Number	Pin Mux / Pin Assignment	Pin Type	Buffer Type	Description
CAN0Rx	33	PA0 (7)	I	TTL	CAN module 0 receive.

Table 22-1. Controller Area Network Signals (128TQFP) (continued)

Pin Name	Pin Number	Pin Mux / Pin Assignment	Pin Type	Buffer Type	Description
CAN0Tx	34	PA1 (7)	O	TTL	CAN module 0 transmit.
CAN1Rx	95	PB0 (7)	I	TTL	CAN module 1 receive.
CAN1Tx	96	PB1 (7)	O	TTL	CAN module 1 transmit.

22.3 Functional Description

The TM4C129ENCPDT CAN controller conforms to the CAN protocol version 2.0 (parts A and B). Message transfers that include data, remote, error, and overload frames with an 11-bit identifier (standard) or a 29-bit identifier (extended) are supported. Transfer rates can be programmed up to 1 Mbps.

The CAN module consists of three major parts:

- CAN protocol controller and message handler
- Message memory
- CAN register interface

A data frame contains data for transmission, whereas a remote frame contains no data and is used to request the transmission of a specific message object. The CAN data/remote frame is constructed as shown in Figure 22-2.

Figure 22-2. CAN Data/Remote Frame

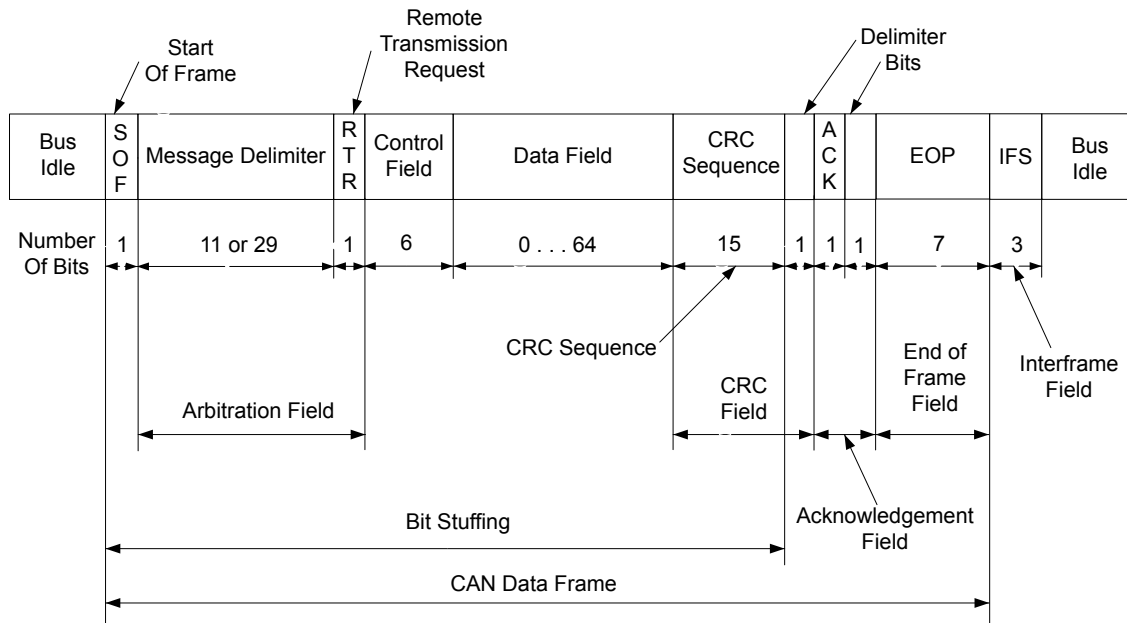

The protocol controller transfers and receives the serial data from the CAN bus and passes the data on to the message handler. The message handler then loads this information into the appropriate message object based on the current filtering and identifiers in the message object memory. The message handler is also responsible for generating interrupts based on events on the CAN bus.

The message object memory is a set of 32 identical memory blocks that hold the current configuration, status, and actual data for each message object. These memory blocks are accessed via either of the CAN message object register interfaces.

The message memory is not directly accessible in the TM4C129ENCPDT memory map, so the TM4C129ENCPDT CAN controller provides an interface to communicate with the message memory via two CAN interface register sets for communicating with the message objects. These two interfaces must be used to read or write to each message object. The two message object interfaces allow parallel access to the CAN controller message objects when multiple objects may have new information that must be processed. In general, one interface is used for transmit data and one for receive data.

22.3.1 Initialization

To use the CAN controller, the peripheral clock must be enabled using the **RCGC0** register (see page 402). In addition, the clock to the appropriate GPIO module must be enabled via the **RCGC2** register (see page 402). To find out which GPIO port to enable, refer to Table 29-4 on page 1921. Set the GPIO **AFSEL** bits for the appropriate pins (see page 778). Configure the **PMC_n** fields in the **GPIOPCTL** register to assign the CAN signals to the appropriate pins. See page 795 and Table 29-5 on page 1932.

Software initialization is started by setting the **INIT** bit in the **CAN Control (CANCTL)** register (with software or by a hardware reset) or by going bus-off, which occurs when the transmitter's error counter exceeds a count of 255. While **INIT** is set, all message transfers to and from the CAN bus are stopped and the **CAN_nTX** signal is held High. Entering the initialization state does not change the configuration of the CAN controller, the message objects, or the error counters. However, some configuration registers are only accessible while in the initialization state.

To initialize the CAN controller, set the **CAN Bit Timing (CANBIT)** register and configure each message object. If a message object is not needed, label it as not valid by clearing the **MSGVAL** bit in the **CAN IF_n Arbitration 2 (CANIF_nARB2)** register. Otherwise, the whole message object must be initialized, as the fields of the message object may not have valid information, causing unexpected results. Both the **INIT** and **CCE** bits in the **CANCTL** register must be set in order to access the **CANBIT** register and the **CAN Baud Rate Prescaler Extension (CANBRPE)** register to configure the bit timing. To leave the initialization state, the **INIT** bit must be cleared. Afterwards, the internal Bit Stream Processor (BSP) synchronizes itself to the data transfer on the CAN bus by waiting for the occurrence of a sequence of 11 consecutive recessive bits (indicating a bus idle condition) before it takes part in bus activities and starts message transfers. Message object initialization does not require the CAN to be in the initialization state and can be done on the fly. However, message objects should all be configured to particular identifiers or set to not valid before message transfer starts. To change the configuration of a message object during normal operation, clear the **MSGVAL** bit in the **CANIF_nARB2** register to indicate that the message object is not valid during the change. When the configuration is completed, set the **MSGVAL** bit again to indicate that the message object is once again valid.

22.3.2 Operation

Two sets of CAN Interface Registers (**CANIF1_x** and **CANIF2_x**) are used to access the message objects in the Message RAM. The CAN controller coordinates transfers to and from the Message RAM to and from the registers. The two sets are independent and identical and can be used to queue transactions. Generally, one interface is used to transmit data and one is used to receive data.

Once the CAN module is initialized and the **INIT** bit in the **CANCTL** register is cleared, the CAN module synchronizes itself to the CAN bus and starts the message transfer. As each message is

received, it goes through the message handler's filtering process, and if it passes through the filter, is stored in the message object specified by the `MNUM` bit in the **CAN IFn Command Request (CANIFnCRQ)** register. The whole message (including all arbitration bits, data-length code, and eight data bytes) is stored in the message object. If the Identifier Mask (the `MSK` bits in the **CAN IFn Mask 1** and **CAN IFn Mask 2 (CANIFnMSKn)** registers) is used, the arbitration bits that are masked to "don't care" may be overwritten in the message object.

The CPU may read or write each message at any time via the CAN Interface Registers. The message handler guarantees data consistency in case of concurrent accesses.

The transmission of message objects is under the control of the software that is managing the CAN hardware. Message objects can be used for one-time data transfers or can be permanent message objects used to respond in a more periodic manner. Permanent message objects have all arbitration and control set up, and only the data bytes are updated. At the start of transmission, the appropriate `TXRQST` bit in the **CAN Transmission Request n (CANTXRQn)** register and the `NEWDAT` bit in the **CAN New Data n (CANNWDAn)** register are set. If several transmit messages are assigned to the same message object (when the number of message objects is not sufficient), the whole message object has to be configured before the transmission of this message is requested.

The transmission of any number of message objects may be requested at the same time; they are transmitted according to their internal priority, which is based on the message identifier (`MNUM`) for the message object, with 1 being the highest priority and 32 being the lowest priority. Messages may be updated or set to not valid any time, even when their requested transmission is still pending. The old data is discarded when a message is updated before its pending transmission has started. Depending on the configuration of the message object, the transmission of a message may be requested autonomously by the reception of a remote frame with a matching identifier.

Transmission can be automatically started by the reception of a matching remote frame. To enable this mode, set the `RMTEN` bit in the **CAN IFn Message Control (CANIFnMCTL)** register. A matching received remote frame causes the `TXRQST` bit to be set, and the message object automatically transfers its data or generates an interrupt indicating a remote frame was requested. A remote frame can be strictly a single message identifier, or it can be a range of values specified in the message object. The CAN mask registers, **CANIFnMSKn**, configure which groups of frames are identified as remote frame requests. The `UMASK` bit in the **CANIFnMCTL** register enables the `MSK` bits in the **CANIFnMSKn** register to filter which frames are identified as a remote frame request. The `MXTD` bit in the **CANIFnMSK2** register should be set if a remote frame request is expected to be triggered by 29-bit extended identifiers.

22.3.3 Transmitting Message Objects

If the internal transmit shift register of the CAN module is ready for loading, and if a data transfer is not occurring between the CAN Interface Registers and message RAM, the valid message object with the highest priority that has a pending transmission request is loaded into the transmit shift register by the message handler and the transmission is started. The message object's `NEWDAT` bit in the **CANNWDAn** register is cleared. After a successful transmission, and if no new data was written to the message object since the start of the transmission, the `TXRQST` bit in the **CANTXRQn** register is cleared. If the CAN controller is configured to interrupt on a successful transmission of a message object, (the `TXIE` bit in the **CAN IFn Message Control (CANIFnMCTL)** register is set), the `INTPND` bit in the **CANIFnMCTL** register is set after a successful transmission. If the CAN module has lost the arbitration or if an error occurred during the transmission, the message is re-transmitted as soon as the CAN bus is free again. If, meanwhile, the transmission of a message with higher priority has been requested, the messages are transmitted in the order of their priority.

22.3.4 Configuring a Transmit Message Object

The following steps illustrate how to configure a transmit message object.

1. In the **CAN IFn Command Mask (CANIFnCMASK)** register:
 - Set the `WRNRD` bit to specify a write to the **CANIFnCMASK** register; specify whether to transfer the `IDMASK`, `DIR`, and `MXTD` of the message object into the **CAN IFn** registers using the `MASK` bit
 - Specify whether to transfer the `ID`, `DIR`, `XTD`, and `MSGVAL` of the message object into the interface registers using the `ARB` bit
 - Specify whether to transfer the control bits into the interface registers using the `CONTROL` bit
 - Specify whether to clear the `INTPND` bit in the **CANIFnMCTL** register using the `CLRINTPND` bit
 - Specify whether to clear the `NEWDAT` bit in the **CANNWDAn** register using the `NEWDAT` bit
 - Specify which bits to transfer using the `DATAA` and `DATAB` bits
2. In the **CANIFnMSK1** register, use the `MSK[15:0]` bits to specify which of the bits in the 29-bit or 11-bit message identifier are used for acceptance filtering. Note that `MSK[15:0]` in this register are used for bits [15:0] of the 29-bit message identifier and are not used for an 11-bit identifier. A value of 0x00 enables all messages to pass through the acceptance filtering. Also note that in order for these bits to be used for acceptance filtering, they must be enabled by setting the `UMASK` bit in the **CANIFnMCTL** register.
3. In the **CANIFnMSK2** register, use the `MSK[12:0]` bits to specify which of the bits in the 29-bit or 11-bit message identifier are used for acceptance filtering. Note that `MSK[12:0]` are used for bits [28:16] of the 29-bit message identifier; whereas `MSK[12:2]` are used for bits [10:0] of the 11-bit message identifier. Use the `MXTD` and `MDIR` bits to specify whether to use `XTD` and `DIR` for acceptance filtering. A value of 0x00 enables all messages to pass through the acceptance filtering. Also note that in order for these bits to be used for acceptance filtering, they must be enabled by setting the `UMASK` bit in the **CANIFnMCTL** register.
4. For a 29-bit identifier, configure `ID[15:0]` in the **CANIFnARB1** register for bits [15:0] of the message identifier and `ID[12:0]` in the **CANIFnARB2** register for bits [28:16] of the message identifier. Set the `XTD` bit to indicate an extended identifier; set the `DIR` bit to indicate transmit; and set the `MSGVAL` bit to indicate that the message object is valid.
5. For an 11-bit identifier, disregard the **CANIFnARB1** register and configure `ID[12:2]` in the **CANIFnARB2** register for bits [10:0] of the message identifier. Clear the `XTD` bit to indicate a standard identifier; set the `DIR` bit to indicate transmit; and set the `MSGVAL` bit to indicate that the message object is valid.
6. In the **CANIFnMCTL** register:
 - Optionally set the `UMASK` bit to enable the mask (`MSK`, `MXTD`, and `MDIR` specified in the **CANIFnMSK1** and **CANIFnMSK2** registers) for acceptance filtering
 - Optionally set the `TXIE` bit to enable the `INTPND` bit to be set after a successful transmission

- Optionally set the `RMTEN` bit to enable the `TXRQST` bit to be set on the reception of a matching remote frame allowing automatic transmission
 - Set the `EOB` bit for a single message object
 - Configure the `DLC[3:0]` field to specify the size of the data frame. Take care during this configuration not to set the `NEWDAT`, `MSGLST`, `INTPND` or `TXRQST` bits.
7. Load the data to be transmitted into the **CAN IFn Data (CANIFnDA1, CANIFnDA2, CANIFnDB1, CANIFnDB2)** registers. Byte 0 of the CAN data frame is stored in `DATA[7:0]` in the **CANIFnDA1** register.
 8. Program the number of the message object to be transmitted in the `MNUM` field in the **CAN IFn Command Request (CANIFnCRQ)** register.
 9. When everything is properly configured, set the `TXRQST` bit in the **CANIFnMCTL** register. Once this bit is set, the message object is available to be transmitted, depending on priority and bus availability. Note that setting the `RMTEN` bit in the **CANIFnMCTL** register can also start message transmission if a matching remote frame has been received.

22.3.5 Updating a Transmit Message Object

The CPU may update the data bytes of a Transmit Message Object any time via the CAN Interface Registers and neither the `MSGVAL` bit in the **CANIFnARB2** register nor the `TXRQST` bits in the **CANIFnMCTL** register have to be cleared before the update.

Even if only some of the data bytes are to be updated, all four bytes of the corresponding **CANIFnDAn/CANIFnDBn** register have to be valid before the content of that register is transferred to the message object. Either the CPU must write all four bytes into the **CANIFnDAn/CANIFnDBn** register or the message object is transferred to the **CANIFnDAn/CANIFnDBn** register before the CPU writes the new data bytes.

In order to only update the data in a message object, the `WRNRD`, `DATAA` and `DATAB` bits in the **CANIFnMSKn** register are set, followed by writing the updated data into **CANIFnDA1**, **CANIFnDA2**, **CANIFnDB1**, and **CANIFnDB2** registers, and then the number of the message object is written to the `MNUM` field in the **CAN IFn Command Request (CANIFnCRQ)** register. To begin transmission of the new data as soon as possible, set the `TXRQST` bit in the **CANIFnMSKn** register.

To prevent the clearing of the `TXRQST` bit in the **CANIFnMCTL** register at the end of a transmission that may already be in progress while the data is updated, the `NEWDAT` and `TXRQST` bits have to be set at the same time in the **CANIFnMCTL** register. When these bits are set at the same time, `NEWDAT` is cleared as soon as the new transmission has started.

22.3.6 Accepting Received Message Objects

When the arbitration and control field (the `ID` and `XTD` bits in the **CANIFnARB2** and the `RMTEN` and `DLC[3:0]` bits of the **CANIFnMCTL** register) of an incoming message is completely shifted into the CAN controller, the message handling capability of the controller starts scanning the message RAM for a matching valid message object. To scan the message RAM for a matching message object, the controller uses the acceptance filtering programmed through the mask bits in the **CANIFnMSKn** register and enabled using the `UMASK` bit in the **CANIFnMCTL** register. Each valid message object, starting with object 1, is compared with the incoming message to locate a matching message object in the message RAM. If a match occurs, the scanning is stopped and the message handler proceeds depending on whether it is a data frame or remote frame that was received.

22.3.7 Receiving a Data Frame

The message handler stores the message from the CAN controller receive shift register into the matching message object in the message RAM. The data bytes, all arbitration bits, and the `DLC` bits are all stored into the corresponding message object. In this manner, the data bytes are connected with the identifier even if arbitration masks are used. The `NEWDAT` bit of the `CANIFnMCTL` register is set to indicate that new data has been received. The CPU should clear this bit when it reads the message object to indicate to the controller that the message has been received, and the buffer is free to receive more messages. If the CAN controller receives a message and the `NEWDAT` bit is already set, the `MSGLST` bit in the `CANIFnMCTL` register is set to indicate that the previous data was lost. If the system requires an interrupt on successful reception of a frame, the `RXIE` bit of the `CANIFnMCTL` register should be set. In this case, the `INTPND` bit of the same register is set, causing the `CANINT` register to point to the message object that just received a message. The `TXRQST` bit of this message object should be cleared to prevent the transmission of a remote frame.

22.3.8 Receiving a Remote Frame

A remote frame contains no data, but instead specifies which object should be transmitted. When a remote frame is received, three different configurations of the matching message object have to be considered:

Table 22-2. Message Object Configurations

Configuration in <code>CANIFnMCTL</code>	Description
<ul style="list-style-type: none"> ■ <code>DIR = 1</code> (direction = transmit); programmed in the <code>CANIFnARB2</code> register ■ <code>RMTEN = 1</code> (set the <code>TXRQST</code> bit of the <code>CANIFnMCTL</code> register at reception of the frame to enable transmission) ■ <code>UMASK = 1</code> or <code>0</code> 	At the reception of a matching remote frame, the <code>TXRQST</code> bit of this message object is set. The rest of the message object remains unchanged, and the controller automatically transfers the data in the message object as soon as possible.
<ul style="list-style-type: none"> ■ <code>DIR = 1</code> (direction = transmit); programmed in the <code>CANIFnARB2</code> register ■ <code>RMTEN = 0</code> (do not change the <code>TXRQST</code> bit of the <code>CANIFnMCTL</code> register at reception of the frame) ■ <code>UMASK = 0</code> (ignore mask in the <code>CANIFnMSKn</code> register) 	At the reception of a matching remote frame, the <code>TXRQST</code> bit of this message object remains unchanged, and the remote frame is ignored. This remote frame is disabled, the data is not transferred and nothing indicates that the remote frame ever happened.
<ul style="list-style-type: none"> ■ <code>DIR = 1</code> (direction = transmit); programmed in the <code>CANIFnARB2</code> register ■ <code>RMTEN = 0</code> (do not change the <code>TXRQST</code> bit of the <code>CANIFnMCTL</code> register at reception of the frame) ■ <code>UMASK = 1</code> (use mask (<code>MSK</code>, <code>MXTD</code>, and <code>MDIR</code> in the <code>CANIFnMSKn</code> register) for acceptance filtering) 	At the reception of a matching remote frame, the <code>TXRQST</code> bit of this message object is cleared. The arbitration and control field (<code>ID + XTD + RMTEN + DLC</code>) from the shift register is stored into the message object in the message RAM, and the <code>NEWDAT</code> bit of this message object is set. The data field of the message object remains unchanged; the remote frame is treated similar to a received data frame. This mode is useful for a remote data request from another CAN device for which the TM4C129ENCPDT controller does not have readily available data. The software must fill the data and answer the frame manually.

22.3.9 Receive/Transmit Priority

The receive/transmit priority for the message objects is controlled by the message number. Message object 1 has the highest priority, while message object 32 has the lowest priority. If more than one transmission request is pending, the message objects are transmitted in order based on the message

object with the lowest message number. This prioritization is separate from that of the message identifier which is enforced by the CAN bus. As a result, if message object 1 and message object 2 both have valid messages to be transmitted, message object 1 is always transmitted first regardless of the message identifier in the message object itself.

22.3.10 Configuring a Receive Message Object

The following steps illustrate how to configure a receive message object.

1. Program the **CAN IFn Command Mask (CANIFnCMASK)** register as described in the “Configuring a Transmit Message Object” on page 1485 section, except that the **WRNRD** bit is set to specify a write to the message RAM.
2. Program the **CANIFnMSK1** and **CANIFnMSK2** registers as described in the “Configuring a Transmit Message Object” on page 1485 section to configure which bits are used for acceptance filtering. Note that in order for these bits to be used for acceptance filtering, they must be enabled by setting the **UMASK** bit in the **CANIFnMCTL** register.
3. In the **CANIFnMSK2** register, use the **MSK[12:0]** bits to specify which of the bits in the 29-bit or 11-bit message identifier are used for acceptance filtering. Note that **MSK[12:0]** are used for bits [28:16] of the 29-bit message identifier; whereas **MSK[12:2]** are used for bits [10:0] of the 11-bit message identifier. Use the **MXTD** and **MDIR** bits to specify whether to use **XTD** and **DIR** for acceptance filtering. A value of 0x00 enables all messages to pass through the acceptance filtering. Also note that in order for these bits to be used for acceptance filtering, they must be enabled by setting the **UMASK** bit in the **CANIFnMCTL** register.
4. Program the **CANIFnARB1** and **CANIFnARB2** registers as described in the “Configuring a Transmit Message Object” on page 1485 section to program **XTD** and **ID** bits for the message identifier to be received; set the **MSGVAL** bit to indicate a valid message; and clear the **DIR** bit to specify receive.
5. In the **CANIFnMCTL** register:
 - Optionally set the **UMASK** bit to enable the mask (**MSK**, **MXTD**, and **MDIR** specified in the **CANIFnMSK1** and **CANIFnMSK2** registers) for acceptance filtering
 - Optionally set the **RXIE** bit to enable the **INTPND** bit to be set after a successful reception
 - Clear the **RMTEN** bit to leave the **TXRQST** bit unchanged
 - Set the **EOB** bit for a single message object
 - Configure the **DLC[3:0]** field to specify the size of the data frameTake care during this configuration not to set the **NEWDAT**, **MSGLST**, **INTPND** or **TXRQST** bits.
6. Program the number of the message object to be received in the **MNUM** field in the **CAN IFn Command Request (CANIFnCRQ)** register. Reception of the message object begins as soon as a matching frame is available on the CAN bus.

When the message handler stores a data frame in the message object, it stores the received Data Length Code and eight data bytes in the **CANIFnDA1**, **CANIFnDA2**, **CANIFnDB1**, and **CANIFnDB2** register. Byte 0 of the CAN data frame is stored in **DATA[7:0]** in the **CANIFnDA1** register. If the Data Length Code is less than 8, the remaining bytes of the message object are overwritten by unspecified values.

The CAN mask registers can be used to allow groups of data frames to be received by a message object. The CAN mask registers, **CANIFnMSK_n**, configure which groups of frames are received by a message object. The **UMASK** bit in the **CANIFnMCTL** register enables the **MSK** bits in the **CANIFnMSK_n** register to filter which frames are received. The **MXTD** bit in the **CANIFnMSK2** register should be set if only 29-bit extended identifiers are expected by this message object.

22.3.11 Handling of Received Message Objects

The CPU may read a received message any time via the CAN Interface registers because the data consistency is guaranteed by the message handler state machine.

Typically, the CPU first writes 0x007F to the **CANIFnCMSK** register and then writes the number of the message object to the **CANIFnCRQ** register. That combination transfers the whole received message from the message RAM into the Message Buffer registers (**CANIFnMSK_n**, **CANIFnARB_n**, and **CANIFnMCTL**). Additionally, the **NEWDAT** and **INTPND** bits are cleared in the message RAM, acknowledging that the message has been read and clearing the pending interrupt generated by this message object.

If the message object uses masks for acceptance filtering, the **CANIFnARB_n** registers show the full, unmasked ID for the received message.

The **NEWDAT** bit in the **CANIFnMCTL** register shows whether a new message has been received since the last time this message object was read. The **MSGLST** bit in the **CANIFnMCTL** register shows whether more than one message has been received since the last time this message object was read. **MSGLST** is not automatically cleared, and should be cleared by software after reading its status.

Using a remote frame, the CPU may request new data from another CAN node on the CAN bus. Setting the **TXRQST** bit of a receive object causes the transmission of a remote frame with the receive object's identifier. This remote frame triggers the other CAN node to start the transmission of the matching data frame. If the matching data frame is received before the remote frame could be transmitted, the **TXRQST** bit is automatically reset. This prevents the possible loss of data when the other device on the CAN bus has already transmitted the data slightly earlier than expected.

22.3.11.1 Configuration of a FIFO Buffer

With the exception of the **EOB** bit in the **CANIFnMCTL** register, the configuration of receive message objects belonging to a FIFO buffer is the same as the configuration of a single receive message object (see “Configuring a Receive Message Object” on page 1488). To concatenate two or more message objects into a FIFO buffer, the identifiers and masks (if used) of these message objects have to be programmed to matching values. Due to the implicit priority of the message objects, the message object with the lowest message object number is the first message object in a FIFO buffer. The **EOB** bit of all message objects of a FIFO buffer except the last one must be cleared. The **EOB** bit of the last message object of a FIFO buffer is set, indicating it is the last entry in the buffer.

22.3.11.2 Reception of Messages with FIFO Buffers

Received messages with identifiers matching to a FIFO buffer are stored starting with the message object with the lowest message number. When a message is stored into a message object of a FIFO buffer, the **NEWDAT** of the **CANIFnMCTL** register bit of this message object is set. By setting **NEWDAT** while **EOB** is clear, the message object is locked and cannot be written to by the message handler until the CPU has cleared the **NEWDAT** bit. Messages are stored into a FIFO buffer until the last message object of this FIFO buffer is reached. Until all of the preceding message objects have been released by clearing the **NEWDAT** bit, all further messages for this FIFO buffer are written into the last message object of the FIFO buffer and therefore overwrite previous messages.

22.3.11.3 Reading from a FIFO Buffer

When the CPU transfers the contents of a message object from a FIFO buffer by writing its number to the **CANIFnCRQ** register, the **TXRQST** and **CLRINTPND** bits in the **CANIFnCMSK** register should be set such that the **NEWDAT** and **INTPEND** bits in the **CANIFnMCTL** register are cleared after the read. The values of these bits in the **CANIFnMCTL** register always reflect the status of the message object before the bits are cleared. To assure the correct function of a FIFO buffer, the CPU should read out the message objects starting with the message object with the lowest message number. When reading from the FIFO buffer, the user should be aware that a new received message is placed in the message object with the lowest message number for which the **NEWDAT** bit of the **CANIFnMCTL** register is clear. As a result, the order of the received messages in the FIFO is not guaranteed. Figure 22-3 on page 1491 shows how a set of message objects which are concatenated to a FIFO Buffer can be handled by the CPU.

Figure 22-3. Message Objects in a FIFO Buffer



22.3.12 Handling of Interrupts

If several interrupts are pending, the **CAN Interrupt (CANINT)** register points to the pending interrupt with the highest priority, disregarding their chronological order. The status interrupt has the highest

priority. Among the message interrupts, the message object's interrupt with the lowest message number has the highest priority. A message interrupt is cleared by clearing the message object's `INTPND` bit in the `CANIFnMCTL` register or by reading the **CAN Status (CANSTS)** register. The status Interrupt is cleared by reading the **CANSTS** register.

The interrupt identifier `INTID` in the **CANINT** register indicates the cause of the interrupt. When no interrupt is pending, the register reads as `0x0000`. If the value of the `INTID` field is different from 0, then an interrupt is pending. If the `IE` bit is set in the **CANCTL** register, the interrupt line to the interrupt controller is active. The interrupt line remains active until the `INTID` field is 0, meaning that all interrupt sources have been cleared (the cause of the interrupt is reset), or until `IE` is cleared, which disables interrupts from the CAN controller.

The `INTID` field of the **CANINT** register points to the pending message interrupt with the highest interrupt priority. The `SIE` bit in the **CANCTL** register controls whether a change of the `RXOK`, `TXOK`, and `LEC` bits in the **CANSTS** register can cause an interrupt. The `EIE` bit in the **CANCTL** register controls whether a change of the `BOFF` and `EWARN` bits in the **CANSTS** register can cause an interrupt. The `IE` bit in the **CANCTL** register controls whether any interrupt from the CAN controller actually generates an interrupt to the interrupt controller. The **CANINT** register is updated even when the `IE` bit in the **CANCTL** register is clear, but the interrupt is not indicated to the CPU.

A value of `0x8000` in the **CANINT** register indicates that an interrupt is pending because the CAN module has updated, but not necessarily changed, the **CANSTS** register, indicating that either an error or status interrupt has been generated. A write access to the **CANSTS** register can clear the `RXOK`, `TXOK`, and `LEC` bits in that same register; however, the only way to clear the source of a status interrupt is to read the **CANSTS** register.

The source of an interrupt can be determined in two ways during interrupt handling. The first is to read the `INTID` bit in the **CANINT** register to determine the highest priority interrupt that is pending, and the second is to read the **CAN Message Interrupt Pending (CANMSGnINT)** register to see all of the message objects that have pending interrupts.

An interrupt service routine reading the message that is the source of the interrupt may read the message and clear the message object's `INTPND` bit at the same time by setting the `CLRINTPND` bit in the **CANIFnCMSK** register. Once the `INTPND` bit has been cleared, the **CANINT** register contains the message number for the next message object with a pending interrupt.

22.3.13 Test Mode

A Test Mode is provided which allows various diagnostics to be performed. Test Mode is entered by setting the `TEST` bit in the **CANCTL** register. Once in Test Mode, the `TX[1:0]`, `LBACK`, `SILENT` and `BASIC` bits in the **CAN Test (CANTST)** register can be used to put the CAN controller into the various diagnostic modes. The `RX` bit in the **CANTST** register allows monitoring of the `CANnRX` signal. All **CANTST** register functions are disabled when the `TEST` bit is cleared.

22.3.13.1 Silent Mode

Silent Mode can be used to analyze the traffic on a CAN bus without affecting it by the transmission of dominant bits (Acknowledge Bits, Error Frames). The CAN Controller is put in Silent Mode setting the `SILENT` bit in the **CANTST** register. In Silent Mode, the CAN controller is able to receive valid data frames and valid remote frames, but it sends only recessive bits on the CAN bus and cannot start a transmission. If the CAN Controller is required to send a dominant bit (ACK bit, overload flag, or active error flag), the bit is rerouted internally so that the CAN Controller monitors this dominant bit, although the CAN bus remains in recessive state.

22.3.13.2 Loopback Mode

Loopback mode is useful for self-test functions. In Loopback Mode, the CAN Controller internally routes the CAN_nTX signal on to the CAN_nRX signal and treats its own transmitted messages as received messages and stores them (if they pass acceptance filtering) into the message buffer. The CAN Controller is put in Loopback Mode by setting the LBACK bit in the CANTST register. To be independent from external stimulation, the CAN Controller ignores acknowledge errors (a recessive bit sampled in the acknowledge slot of a data/remote frame) in Loopback Mode. The actual value of the CAN_nRX signal is disregarded by the CAN Controller. The transmitted messages can be monitored on the CAN_nTX signal.

22.3.13.3 Loopback Combined with Silent Mode

Loopback Mode and Silent Mode can be combined to allow the CAN Controller to be tested without affecting a running CAN system connected to the CAN_nTX and CAN_nRX signals. In this mode, the CAN_nRX signal is disconnected from the CAN Controller and the CAN_nTX signal is held recessive. This mode is enabled by setting both the LBACK and SILENT bits in the CANTST register.

22.3.13.4 Basic Mode

Basic Mode allows the CAN Controller to be operated without the Message RAM. In Basic Mode, The CANIF1 registers are used as the transmit buffer. The transmission of the contents of the IF1 registers is requested by setting the BUSY bit of the CANIF1CRQ register. The CANIF1 registers are locked while the BUSY bit is set. The BUSY bit indicates that a transmission is pending. As soon the CAN bus is idle, the CANIF1 registers are loaded into the shift register of the CAN Controller and transmission is started. When the transmission has completed, the BUSY bit is cleared and the locked CANIF1 registers are released. A pending transmission can be aborted at any time by clearing the BUSY bit in the CANIF1CRQ register while the CANIF1 registers are locked. If the CPU has cleared the BUSY bit, a possible retransmission in case of lost arbitration or an error is disabled.

The CANIF2 Registers are used as a receive buffer. After the reception of a message, the contents of the shift register are stored in the CANIF2 registers, without any acceptance filtering. Additionally, the actual contents of the shift register can be monitored during the message transfer. Each time a read message object is initiated by setting the BUSY bit of the CANIF2CRQ register, the contents of the shift register are stored into the CANIF2 registers.

In Basic Mode, all message-object-related control and status bits and of the control bits of the CANIF_nCMSK registers are not evaluated. The message number of the CANIF_nCRQ registers is also not evaluated. In the CANIF2MCTL register, the NEWDAT and MSGLSST bits retain their function, the DLC[3:0] field shows the received DLC, the other control bits are cleared.

Basic Mode is enabled by setting the BASIC bit in the CANTST register.

22.3.13.5 Transmit Control

Software can directly override control of the CAN_nTX signal in four different ways.

- CAN_nTX is controlled by the CAN Controller
- The sample point is driven on the CAN_nTX signal to monitor the bit timing
- CAN_nTX drives a low value
- CAN_nTX drives a high value

The last two functions, combined with the readable CAN receive pin `CANnRX`, can be used to check the physical layer of the CAN bus.

The Transmit Control function is enabled by programming the `TX[1:0]` field in the **CANTST** register. The three test functions for the `CANnTX` signal interfere with all CAN protocol functions. `TX[1:0]` must be cleared when CAN message transfer or Loopback Mode, Silent Mode, or Basic Mode are selected.

22.3.14 Bit Timing Configuration Error Considerations

Even if minor errors in the configuration of the CAN bit timing do not result in immediate failure, the performance of a CAN network can be reduced significantly. In many cases, the CAN bit synchronization amends a faulty configuration of the CAN bit timing to such a degree that only occasionally an error frame is generated. In the case of arbitration, however, when two or more CAN nodes simultaneously try to transmit a frame, a misplaced sample point may cause one of the transmitters to become error passive. The analysis of such sporadic errors requires a detailed knowledge of the CAN bit synchronization inside a CAN node and of the CAN nodes' interaction on the CAN bus.

22.3.15 Bit Time and Bit Rate

The CAN system supports bit rates in the range of lower than 1 Kbps up to 1000 Kbps. Each member of the CAN network has its own clock generator. The timing parameter of the bit time can be configured individually for each CAN node, creating a common bit rate even though the CAN nodes' oscillator periods may be different.

Because of small variations in frequency caused by changes in temperature or voltage and by deteriorating components, these oscillators are not absolutely stable. As long as the variations remain inside a specific oscillator's tolerance range, the CAN nodes are able to compensate for the different bit rates by periodically resynchronizing to the bit stream.

According to the CAN specification, the bit time is divided into four segments (see Figure 22-4 on page 1495): the Synchronization Segment, the Propagation Time Segment, the Phase Buffer Segment 1, and the Phase Buffer Segment 2. Each segment consists of a specific, programmable number of time quanta (see Table 22-3 on page 1495). The length of the time quantum (t_q), which is the basic time unit of the bit time, is defined by the CAN controller's input clock (f_{sys}) and the Baud Rate Prescaler (**BRP**):

$$t_q = \text{BRP} / f_{sys}$$

The f_{sys} input clock is the system clock frequency as configured by the **RSCLKCFG** register (see page 282).

The Synchronization Segment Sync is that part of the bit time where edges of the CAN bus level are expected to occur; the distance between an edge that occurs outside of `Sync` and the `Sync` is called the phase error of that edge.

The Propagation Time Segment Prop is intended to compensate for the physical delay times within the CAN network.

The Phase Buffer Segments Phase1 and Phase2 surround the Sample Point.

The (Re-)Synchronization Jump Width (SJW) defines how far a resynchronization may move the Sample Point inside the limits defined by the Phase Buffer Segments to compensate for edge phase errors.

A given bit rate may be met by different bit-time configurations, but for the proper function of the CAN network, the physical delay times and the oscillator's tolerance range have to be considered.

Figure 22-4. CAN Bit Time

Table 22-3. CAN Protocol Ranges^a

Parameter	Range	Remark
BRP	[1 .. 64]	Defines the length of the time quantum t_q . The CANBRPE register can be used to extend the range to 1024.
Sync	1 t_q	Fixed length, synchronization of bus input to system clock
Prop	[1 .. 8] t_q	Compensates for the physical delay times
Phase1	[1 .. 8] t_q	May be lengthened temporarily by synchronization
Phase2	[1 .. 8] t_q	May be shortened temporarily by synchronization
SJW	[1 .. 4] t_q	May not be longer than either Phase Buffer Segment

a. This table describes the minimum programmable ranges required by the CAN protocol.

The bit timing configuration is programmed in two register bytes in the **CANBIT** register. In the **CANBIT** register, the four components TSEG2, TSEG1, SJW, and BRP have to be programmed to a numerical value that is one less than its functional value; so instead of values in the range of [1..n], values in the range of [0..n-1] are programmed. That way, for example, SJW (functional range of [1..4]) is represented by only two bits in the SJW bit field. Table 22-4 shows the relationship between the **CANBIT** register values and the parameters.

Table 22-4. CANBIT Register Values

CANBIT Register Field	Setting
TSEG2	Phase2 - 1
TSEG1	Prop + Phase1 - 1
SJW	SJW - 1
BRP	BRP

Therefore, the length of the bit time is (programmed values):

$$[TSEG1 + TSEG2 + 3] \times t_q$$

or (functional values):

$$[Sync + Prop + Phase1 + Phase2] \times t_q$$

The data in the **CANBIT** register is the configuration input of the CAN protocol controller. The baud rate prescaler (configured by the BRP field) defines the length of the time quantum, the basic time

unit of the bit time; the bit timing logic (configured by TSEG1, TSEG2, and SJW) defines the number of time quanta in the bit time.

The processing of the bit time, the calculation of the position of the sample point, and occasional synchronizations are controlled by the CAN controller and are evaluated once per time quantum.

The CAN controller translates messages to and from frames. In addition, the controller generates and discards the enclosing fixed format bits, inserts and extracts stuff bits, calculates and checks the CRC code, performs the error management, and decides which type of synchronization is to be used. The bit value is received or transmitted at the sample point. The information processing time (IPT) is the time after the sample point needed to calculate the next bit to be transmitted on the CAN bus. The IPT includes any of the following: retrieving the next data bit, handling a CRC bit, determining if bit stuffing is required, generating an error flag or simply going idle.

The IPT is application-specific but may not be longer than $2 t_q$; the CAN's IPT is $0 t_q$. Its length is the lower limit of the programmed length of Phase2. In case of synchronization, Phase2 may be shortened to a value less than IPT, which does not affect bus timing.

22.3.16 Calculating the Bit Timing Parameters

Usually, the calculation of the bit timing configuration starts with a required bit rate or bit time. The resulting bit time (1/bit rate) must be an integer multiple of the system clock period.

The bit time may consist of 4 to 25 time quanta. Several combinations may lead to the required bit time, allowing iterations of the following steps.

The first part of the bit time to be defined is Prop. Its length depends on the delay times measured in the system. A maximum bus length as well as a maximum node delay has to be defined for expandable CAN bus systems. The resulting time for Prop is converted into time quanta (rounded up to the nearest integer multiple of t_q).

Sync is $1 t_q$ long (fixed), which leaves $(\text{bit time} - \text{Prop} - 1) t_q$ for the two Phase Buffer Segments. If the number of remaining t_q is even, the Phase Buffer Segments have the same length, that is, Phase2 = Phase1, else Phase2 = Phase1 + 1.

The minimum nominal length of Phase2 has to be regarded as well. Phase2 may not be shorter than the CAN controller's Information Processing Time, which is, depending on the actual implementation, in the range of $[0..2] t_q$.

The length of the synchronization jump width is set to the least of 4, Phase1 or Phase2.

The oscillator tolerance range necessary for the resulting configuration is calculated by the formula given below:

$$(1 - df) \times f_{nom} \leq f_{osc} \leq (1 + df) \times f_{nom}$$

where:

- df = Maximum tolerance of oscillator frequency
- f_{osc} = Actual oscillator frequency
- f_{nom} = Nominal oscillator frequency

Maximum frequency tolerance must take into account the following formulas:

$$df \leq \frac{(Phase_seg1, Phase_seg2) \min}{2 \times (13 \times tbit - Phase_Seg2)}$$

$$df \max = 2 \times df \times f_{nom}$$

where:

- Phase1 and Phase2 are from Table 22-3 on page 1495
- tbit = Bit Time
- dfmax = Maximum difference between two oscillators

If more than one configuration is possible, that configuration allowing the highest oscillator tolerance range should be chosen.

CAN nodes with different system clocks require different configurations to come to the same bit rate. The calculation of the propagation time in the CAN network, based on the nodes with the longest delay times, is done once for the whole network.

The CAN system's oscillator tolerance range is limited by the node with the lowest tolerance range.

The calculation may show that bus length or bit rate have to be decreased or that the oscillator frequencies' stability has to be increased in order to find a protocol-compliant configuration of the CAN bit timing.

22.3.16.1 Example for Bit Timing at High Baud Rate

In this example, the frequency of CAN clock is 25 MHz, and the bit rate is 1 Mbps.

$$\text{bit time} = 1 \mu\text{s} = n * t_q = 5 * t_q$$

$$t_q = 200 \text{ ns}$$

$$t_q = (\text{Baud rate Prescaler}) / \text{CAN Clock}$$

$$\text{Baud rate Prescaler} = t_q * \text{CAN Clock}$$

$$\text{Baud rate Prescaler} = 200\text{E-}9 * 25\text{E}6 = 5$$

$$t_{\text{Sync}} = 1 * t_q = 200 \text{ ns}$$

\\fixed at 1 time quanta

delay of bus driver 50 ns

delay of receiver circuit 30 ns

delay of bus line (40m) 220 ns

$$t_{\text{Prop}} 400 \text{ ns} = 2 * t_q$$

\\400 is next integer multiple of t_q

$$\text{bit time} = t_{\text{Sync}} + t_{\text{TSeg1}} + t_{\text{TSeg2}} = 5 * t_q$$

$$\text{bit time} = t_{\text{Sync}} + t_{\text{Prop}} + t_{\text{Phase 1}} + t_{\text{Phase 2}}$$

$$t_{\text{Phase 1}} + t_{\text{Phase 2}} = \text{bit time} - t_{\text{Sync}} - t_{\text{Prop}}$$

$$t_{\text{Phase 1}} + t_{\text{Phase 2}} = (5 * t_q) - (1 * t_q) - (2 * t_q)$$

$$t_{\text{Phase 1}} + t_{\text{Phase 2}} = 2 * t_q$$

$$t_{\text{Phase 1}} = 1 * t_q$$

$$t_{\text{Phase 2}} = 1 * t_q$$

\\tPhase2 = tPhase1

```

tTSeg1 = tProp + tPhase1
tTSeg1 = (2 * tq) + (1 * tq)
tTSeg1 = 3 * tq

tTSeg2 = tPhase2
tTSeg2 = (Information Processing Time + 1) * tq
tTSeg2 = 1 * tq                \\Assumes IPT=0

tSJW = 1 * tq                \\Least of 4, Phase1 and Phase2
    
```

In the above example, the bit field values for the **CANBIT** register are:

TSEG2	= TSeg2 -1 = 1-1 = 0
TSEG1	= TSeg1 -1 = 3-1 = 2
SJW	= SJW -1 = 1-1 = 0
BRP	= Baud rate prescaler - 1 = 5-1 =4

The final value programmed into the **CANBIT** register = 0x0204.

22.3.16.2 Example for Bit Timing at Low Baud Rate

In this example, the frequency of the CAN clock is 50 MHz, and the bit rate is 100 Kbps.

```

bit time = 10 μs = n * tq = 10 * tq
tq = 1 μs
tq = (Baud rate Prescaler)/CAN Clock
Baud rate Prescaler = tq * CAN Clock
Baud rate Prescaler = 1E-6 * 50E6 = 50

tSync = 1 * tq = 1 μs                \\fixed at 1 time quanta

delay of bus driver 200 ns
delay of receiver circuit 80 ns
delay of bus line (40m) 220 ns
tProp 1 μs = 1 * tq                \\1 μs is next integer multiple of tq

bit time = tSync + tTSeg1 + tTSeg2 = 10 * tq
bit time = tSync + tProp + tPhase 1 + tPhase2
tPhase 1 + tPhase2 = bit time - tSync - tProp
tPhase 1 + tPhase2 = (10 * tq) - (1 * tq) - (1 * tq)
tPhase 1 + tPhase2 = 8 * tq
tPhase1 = 4 * tq
tPhase2 = 4 * tq                \\tPhase1 = tPhase2
    
```

$$tTSeg1 = tProp + tPhase1$$

$$tTSeg1 = (1 * t_q) + (4 * t_q)$$

$$tTSeg1 = 5 * t_q$$

$$tTSeg2 = tPhase2$$

$$tTSeg2 = (\text{Information Processing Time} + 4) * t_q$$

$$tTSeg2 = 4 * t_q \quad \backslash\backslash \text{Assumes IPT}=0$$

$$tSJW = 4 * t_q \quad \backslash\backslash \text{Least of 4, Phase1, and Phase2}$$

TSEG2	= TSeg2 -1 = 4-1 = 3
TSEG1	= TSeg1 -1 = 5-1 = 4
SJW	= SJW -1 = 4-1 = 3
BRP	= Baud rate prescaler - 1 = 50-1 =49

The final value programmed into the **CANBIT** register = 0x34F1.

22.4 Register Map

Table 22-5 on page 1499 lists the registers. All addresses given are relative to the CAN base address of:

- CAN0: 0x4004.0000
- CAN1: 0x4004.1000

Note that the CAN controller clock must be enabled before the registers can be programmed (see page 402). There must be a delay of 3 system clocks after the CAN module clock is enabled before any CAN module registers are accessed.

Table 22-5. CAN Register Map

Offset	Name	Type	Reset	Description	See page
0x000	CANCTL	RW	0x0000.0001	CAN Control	1502
0x004	CANSTS	RW	0x0000.0000	CAN Status	1504
0x008	CANERR	RO	0x0000.0000	CAN Error Counter	1507
0x00C	CANBIT	RW	0x0000.2301	CAN Bit Timing	1508
0x010	CANINT	RO	0x0000.0000	CAN Interrupt	1509
0x014	CANTST	RW	0x0000.0000	CAN Test	1510
0x018	CANBRPE	RW	0x0000.0000	CAN Baud Rate Prescaler Extension	1512
0x020	CANIF1CRQ	RW	0x0000.0001	CAN IF1 Command Request	1513

Table 22-5. CAN Register Map (continued)

Offset	Name	Type	Reset	Description	See page
0x024	CANIF1CMSK	RW	0x0000.0000	CAN IF1 Command Mask	1514
0x028	CANIF1MSK1	RW	0x0000.FFFF	CAN IF1 Mask 1	1517
0x02C	CANIF1MSK2	RW	0x0000.FFFF	CAN IF1 Mask 2	1518
0x030	CANIF1ARB1	RW	0x0000.0000	CAN IF1 Arbitration 1	1520
0x034	CANIF1ARB2	RW	0x0000.0000	CAN IF1 Arbitration 2	1521
0x038	CANIF1MCTL	RW	0x0000.0000	CAN IF1 Message Control	1523
0x03C	CANIF1DA1	RW	0x0000.0000	CAN IF1 Data A1	1526
0x040	CANIF1DA2	RW	0x0000.0000	CAN IF1 Data A2	1526
0x044	CANIF1DB1	RW	0x0000.0000	CAN IF1 Data B1	1526
0x048	CANIF1DB2	RW	0x0000.0000	CAN IF1 Data B2	1526
0x080	CANIF2CRQ	RW	0x0000.0001	CAN IF2 Command Request	1513
0x084	CANIF2CMSK	RW	0x0000.0000	CAN IF2 Command Mask	1514
0x088	CANIF2MSK1	RW	0x0000.FFFF	CAN IF2 Mask 1	1517
0x08C	CANIF2MSK2	RW	0x0000.FFFF	CAN IF2 Mask 2	1518
0x090	CANIF2ARB1	RW	0x0000.0000	CAN IF2 Arbitration 1	1520
0x094	CANIF2ARB2	RW	0x0000.0000	CAN IF2 Arbitration 2	1521
0x098	CANIF2MCTL	RW	0x0000.0000	CAN IF2 Message Control	1523
0x09C	CANIF2DA1	RW	0x0000.0000	CAN IF2 Data A1	1526
0x0A0	CANIF2DA2	RW	0x0000.0000	CAN IF2 Data A2	1526
0x0A4	CANIF2DB1	RW	0x0000.0000	CAN IF2 Data B1	1526
0x0A8	CANIF2DB2	RW	0x0000.0000	CAN IF2 Data B2	1526
0x100	CANTXRQ1	RO	0x0000.0000	CAN Transmission Request 1	1527
0x104	CANTXRQ2	RO	0x0000.0000	CAN Transmission Request 2	1527
0x120	CANNWDA1	RO	0x0000.0000	CAN New Data 1	1528
0x124	CANNWDA2	RO	0x0000.0000	CAN New Data 2	1528
0x140	CANMSG1INT	RO	0x0000.0000	CAN Message 1 Interrupt Pending	1529
0x144	CANMSG2INT	RO	0x0000.0000	CAN Message 2 Interrupt Pending	1529
0x160	CANMSG1VAL	RO	0x0000.0000	CAN Message 1 Valid	1530
0x164	CANMSG2VAL	RO	0x0000.0000	CAN Message 2 Valid	1530

22.5 CAN Register Descriptions

The remainder of this section lists and describes the CAN registers, in numerical order by address offset. There are two sets of Interface Registers that are used to access the Message Objects in

the Message RAM: **CANIF1x** and **CANIF2x**. The function of the two sets are identical and are used to queue transactions.

Register 1: CAN Control (CANCTL), offset 0x000

This control register initializes the module and enables test mode and interrupts.

The bus-off recovery sequence (see CAN Specification Rev. 2.0) cannot be shortened by setting or clearing `INIT`. If the device goes bus-off, it sets `INIT`, stopping all bus activities. Once `INIT` has been cleared by the CPU, the device then waits for 129 occurrences of Bus Idle (129 * 11 consecutive High bits) before resuming normal operations. At the end of the bus-off recovery sequence, the Error Management Counters are reset.

During the waiting time after `INIT` is cleared, each time a sequence of 11 High bits has been monitored, a `BITERROR0` code is written to the **CANSTS** register (the `LEC` field = 0x5), enabling the CPU to readily check whether the CAN bus is stuck Low or continuously disturbed, and to monitor the proceeding of the bus-off recovery sequence.

CAN Control (CANCTL)

CAN0 base: 0x4004.0000
 CAN1 base: 0x4004.1000
 Offset 0x000
 Type RW, reset 0x0000.0001

	31	30	29	28	27	26	25	24	23	22	21	20	19	18	17	16
	reserved															
Type	RO	RO	RO	RO	RO	RO	RO	RO	RO	RO	RO	RO	RO	RO	RO	RO
Reset	0	0	0	0	0	0	0	0	0	0	0	0	0	0	0	0
	15	14	13	12	11	10	9	8	7	6	5	4	3	2	1	0
	reserved								TEST	CCE	DAR	reserved	EIE	SIE	IE	INIT
Type	RO	RO	RO	RO	RO	RO	RO	RO	RW	RW	RW	RO	RW	RW	RW	RW
Reset	0	0	0	0	0	0	0	0	0	0	0	0	0	0	0	1

Bit/Field	Name	Type	Reset	Description						
31:8	reserved	RO	0x0000.00	Software should not rely on the value of a reserved bit. To provide compatibility with future products, the value of a reserved bit should be preserved across a read-modify-write operation.						
7	TEST	RW	0	Test Mode Enable						
				<table border="0"> <tr> <td>Value</td> <td>Description</td> </tr> <tr> <td>0</td> <td>The CAN controller is operating normally.</td> </tr> <tr> <td>1</td> <td>The CAN controller is in test mode.</td> </tr> </table>	Value	Description	0	The CAN controller is operating normally.	1	The CAN controller is in test mode.
Value	Description									
0	The CAN controller is operating normally.									
1	The CAN controller is in test mode.									
6	CCE	RW	0	Configuration Change Enable						
				<table border="0"> <tr> <td>Value</td> <td>Description</td> </tr> <tr> <td>0</td> <td>Write accesses to the CANBIT register are not allowed.</td> </tr> <tr> <td>1</td> <td>Write accesses to the CANBIT register are allowed if the <code>INIT</code> bit is 1.</td> </tr> </table>	Value	Description	0	Write accesses to the CANBIT register are not allowed.	1	Write accesses to the CANBIT register are allowed if the <code>INIT</code> bit is 1.
Value	Description									
0	Write accesses to the CANBIT register are not allowed.									
1	Write accesses to the CANBIT register are allowed if the <code>INIT</code> bit is 1.									
5	DAR	RW	0	Disable Automatic-Retransmission						
				<table border="0"> <tr> <td>Value</td> <td>Description</td> </tr> <tr> <td>0</td> <td>Auto-retransmission of disturbed messages is enabled.</td> </tr> <tr> <td>1</td> <td>Auto-retransmission is disabled.</td> </tr> </table>	Value	Description	0	Auto-retransmission of disturbed messages is enabled.	1	Auto-retransmission is disabled.
Value	Description									
0	Auto-retransmission of disturbed messages is enabled.									
1	Auto-retransmission is disabled.									

Bit/Field	Name	Type	Reset	Description						
4	reserved	RO	0	Software should not rely on the value of a reserved bit. To provide compatibility with future products, the value of a reserved bit should be preserved across a read-modify-write operation.						
3	EIE	RW	0	Error Interrupt Enable <table border="1"> <thead> <tr> <th>Value</th> <th>Description</th> </tr> </thead> <tbody> <tr> <td>0</td> <td>No error status interrupt is generated.</td> </tr> <tr> <td>1</td> <td>A change in the <i>BOFF</i> or <i>EWARN</i> bits in the CANSTS register generates an interrupt.</td> </tr> </tbody> </table>	Value	Description	0	No error status interrupt is generated.	1	A change in the <i>BOFF</i> or <i>EWARN</i> bits in the CANSTS register generates an interrupt.
Value	Description									
0	No error status interrupt is generated.									
1	A change in the <i>BOFF</i> or <i>EWARN</i> bits in the CANSTS register generates an interrupt.									
2	SIE	RW	0	Status Interrupt Enable <table border="1"> <thead> <tr> <th>Value</th> <th>Description</th> </tr> </thead> <tbody> <tr> <td>0</td> <td>No status interrupt is generated.</td> </tr> <tr> <td>1</td> <td>An interrupt is generated when a message has successfully been transmitted or received, or a CAN bus error has been detected. A change in the <i>TXOK</i>, <i>RXOK</i> or <i>LEC</i> bits in the CANSTS register generates an interrupt.</td> </tr> </tbody> </table>	Value	Description	0	No status interrupt is generated.	1	An interrupt is generated when a message has successfully been transmitted or received, or a CAN bus error has been detected. A change in the <i>TXOK</i> , <i>RXOK</i> or <i>LEC</i> bits in the CANSTS register generates an interrupt.
Value	Description									
0	No status interrupt is generated.									
1	An interrupt is generated when a message has successfully been transmitted or received, or a CAN bus error has been detected. A change in the <i>TXOK</i> , <i>RXOK</i> or <i>LEC</i> bits in the CANSTS register generates an interrupt.									
1	IE	RW	0	CAN Interrupt Enable <table border="1"> <thead> <tr> <th>Value</th> <th>Description</th> </tr> </thead> <tbody> <tr> <td>0</td> <td>Interrupts disabled.</td> </tr> <tr> <td>1</td> <td>Interrupts enabled.</td> </tr> </tbody> </table>	Value	Description	0	Interrupts disabled.	1	Interrupts enabled.
Value	Description									
0	Interrupts disabled.									
1	Interrupts enabled.									
0	INIT	RW	1	Initialization <table border="1"> <thead> <tr> <th>Value</th> <th>Description</th> </tr> </thead> <tbody> <tr> <td>0</td> <td>Normal operation.</td> </tr> <tr> <td>1</td> <td>Initialization started.</td> </tr> </tbody> </table>	Value	Description	0	Normal operation.	1	Initialization started.
Value	Description									
0	Normal operation.									
1	Initialization started.									

Register 2: CAN Status (CANSTS), offset 0x004

Important: This register is read-sensitive. See the register description for details.

The status register contains information for interrupt servicing such as Bus-Off, error count threshold, and error types.

The LEC field holds the code that indicates the type of the last error to occur on the CAN bus. This field is cleared when a message has been transferred (reception or transmission) without error. The unused error code 0x7 may be written by the CPU to manually set this field to an invalid error so that it can be checked for a change later.

An error interrupt is generated by the BOFF and EWARN bits, and a status interrupt is generated by the RXOK, TXOK, and LEC bits, if the corresponding enable bits in the **CAN Control (CANCTL)** register are set. A change of the EPASS bit or a write to the RXOK, TXOK, or LEC bits does not generate an interrupt.

Reading the **CAN Status (CANSTS)** register clears the **CAN Interrupt (CANINT)** register, if it is pending.

CAN Status (CANSTS)

CAN0 base: 0x4004.0000
 CAN1 base: 0x4004.1000
 Offset 0x004
 Type RW, reset 0x0000.0000

	31	30	29	28	27	26	25	24	23	22	21	20	19	18	17	16
	reserved															
Type	RO	RO	RO	RO	RO	RO	RO	RO	RO	RO	RO	RO	RO	RO	RO	RO
Reset	0	0	0	0	0	0	0	0	0	0	0	0	0	0	0	0
	15	14	13	12	11	10	9	8	7	6	5	4	3	2	1	0
	reserved								BOFF	EWARN	EPASS	RXOK	TXOK	LEC		
Type	RO	RO	RO	RO	RO	RO	RO	RO	RO	RO	RO	RW	RW	RW	RW	RW
Reset	0	0	0	0	0	0	0	0	0	0	0	0	0	0	0	0

Bit/Field	Name	Type	Reset	Description						
31:8	reserved	RO	0x0000.00	Software should not rely on the value of a reserved bit. To provide compatibility with future products, the value of a reserved bit should be preserved across a read-modify-write operation.						
7	BOFF	RO	0	Bus-Off Status						
				<table border="0"> <tr> <td style="padding-right: 20px;">Value</td> <td>Description</td> </tr> <tr> <td>0</td> <td>The CAN controller is not in bus-off state.</td> </tr> <tr> <td>1</td> <td>The CAN controller is in bus-off state.</td> </tr> </table>	Value	Description	0	The CAN controller is not in bus-off state.	1	The CAN controller is in bus-off state.
Value	Description									
0	The CAN controller is not in bus-off state.									
1	The CAN controller is in bus-off state.									
6	EWARN	RO	0	Warning Status						
				<table border="0"> <tr> <td style="padding-right: 20px;">Value</td> <td>Description</td> </tr> <tr> <td>0</td> <td>Both error counters are below the error warning limit of 96.</td> </tr> <tr> <td>1</td> <td>At least one of the error counters has reached the error warning limit of 96.</td> </tr> </table>	Value	Description	0	Both error counters are below the error warning limit of 96.	1	At least one of the error counters has reached the error warning limit of 96.
Value	Description									
0	Both error counters are below the error warning limit of 96.									
1	At least one of the error counters has reached the error warning limit of 96.									

Bit/Field	Name	Type	Reset	Description						
5	EPASS	RO	0	<p>Error Passive</p> <table border="1"> <thead> <tr> <th>Value</th> <th>Description</th> </tr> </thead> <tbody> <tr> <td>0</td> <td>The CAN module is in the Error Active state, that is, the receive or transmit error count is less than or equal to 127.</td> </tr> <tr> <td>1</td> <td>The CAN module is in the Error Passive state, that is, the receive or transmit error count is greater than 127.</td> </tr> </tbody> </table>	Value	Description	0	The CAN module is in the Error Active state, that is, the receive or transmit error count is less than or equal to 127.	1	The CAN module is in the Error Passive state, that is, the receive or transmit error count is greater than 127.
Value	Description									
0	The CAN module is in the Error Active state, that is, the receive or transmit error count is less than or equal to 127.									
1	The CAN module is in the Error Passive state, that is, the receive or transmit error count is greater than 127.									
4	RXOK	RW	0	<p>Received a Message Successfully</p> <table border="1"> <thead> <tr> <th>Value</th> <th>Description</th> </tr> </thead> <tbody> <tr> <td>0</td> <td>Since this bit was last cleared, no message has been successfully received.</td> </tr> <tr> <td>1</td> <td>Since this bit was last cleared, a message has been successfully received, independent of the result of the acceptance filtering.</td> </tr> </tbody> </table> <p>This bit must be cleared by writing a 0 to it.</p>	Value	Description	0	Since this bit was last cleared, no message has been successfully received.	1	Since this bit was last cleared, a message has been successfully received, independent of the result of the acceptance filtering.
Value	Description									
0	Since this bit was last cleared, no message has been successfully received.									
1	Since this bit was last cleared, a message has been successfully received, independent of the result of the acceptance filtering.									
3	TXOK	RW	0	<p>Transmitted a Message Successfully</p> <table border="1"> <thead> <tr> <th>Value</th> <th>Description</th> </tr> </thead> <tbody> <tr> <td>0</td> <td>Since this bit was last cleared, no message has been successfully transmitted.</td> </tr> <tr> <td>1</td> <td>Since this bit was last cleared, a message has been successfully transmitted error-free and acknowledged by at least one other node.</td> </tr> </tbody> </table> <p>This bit must be cleared by writing a 0 to it.</p>	Value	Description	0	Since this bit was last cleared, no message has been successfully transmitted.	1	Since this bit was last cleared, a message has been successfully transmitted error-free and acknowledged by at least one other node.
Value	Description									
0	Since this bit was last cleared, no message has been successfully transmitted.									
1	Since this bit was last cleared, a message has been successfully transmitted error-free and acknowledged by at least one other node.									

Bit/Field	Name	Type	Reset	Description																																				
2:0	LEC	RW	0x0	<p>Last Error Code</p> <p>This is the type of the last error to occur on the CAN bus.</p> <table border="1"> <thead> <tr> <th>Value</th> <th>Description</th> </tr> </thead> <tbody> <tr> <td>0x0</td> <td>No Error</td> </tr> <tr> <td>0x1</td> <td>Stuff Error</td> </tr> <tr> <td></td> <td>More than 5 equal bits in a sequence have occurred in a part of a received message where this is not allowed.</td> </tr> <tr> <td>0x2</td> <td>Format Error</td> </tr> <tr> <td></td> <td>A fixed format part of the received frame has the wrong format.</td> </tr> <tr> <td>0x3</td> <td>ACK Error</td> </tr> <tr> <td></td> <td>The message transmitted was not acknowledged by another node.</td> </tr> <tr> <td>0x4</td> <td>Bit 1 Error</td> </tr> <tr> <td></td> <td>When a message is transmitted, the CAN controller monitors the data lines to detect any conflicts. When the arbitration field is transmitted, data conflicts are a part of the arbitration protocol. When other frame fields are transmitted, data conflicts are considered errors.</td> </tr> <tr> <td></td> <td>A Bit 1 Error indicates that the device wanted to send a High level (logical 1) but the monitored bus value was Low (logical 0).</td> </tr> <tr> <td>0x5</td> <td>Bit 0 Error</td> </tr> <tr> <td></td> <td>A Bit 0 Error indicates that the device wanted to send a Low level (logical 0), but the monitored bus value was High (logical 1).</td> </tr> <tr> <td></td> <td>During bus-off recovery, this status is set each time a sequence of 11 High bits has been monitored. By checking for this status, software can monitor the proceeding of the bus-off recovery sequence without any disturbances to the bus.</td> </tr> <tr> <td>0x6</td> <td>CRC Error</td> </tr> <tr> <td></td> <td>The CRC checksum was incorrect in the received message, indicating that the calculated value received did not match the calculated CRC of the data.</td> </tr> <tr> <td>0x7</td> <td>No Event</td> </tr> <tr> <td></td> <td>When the LEC bit shows this value, no CAN bus event was detected since this value was written to the LEC field.</td> </tr> </tbody> </table>	Value	Description	0x0	No Error	0x1	Stuff Error		More than 5 equal bits in a sequence have occurred in a part of a received message where this is not allowed.	0x2	Format Error		A fixed format part of the received frame has the wrong format.	0x3	ACK Error		The message transmitted was not acknowledged by another node.	0x4	Bit 1 Error		When a message is transmitted, the CAN controller monitors the data lines to detect any conflicts. When the arbitration field is transmitted, data conflicts are a part of the arbitration protocol. When other frame fields are transmitted, data conflicts are considered errors.		A Bit 1 Error indicates that the device wanted to send a High level (logical 1) but the monitored bus value was Low (logical 0).	0x5	Bit 0 Error		A Bit 0 Error indicates that the device wanted to send a Low level (logical 0), but the monitored bus value was High (logical 1).		During bus-off recovery, this status is set each time a sequence of 11 High bits has been monitored. By checking for this status, software can monitor the proceeding of the bus-off recovery sequence without any disturbances to the bus.	0x6	CRC Error		The CRC checksum was incorrect in the received message, indicating that the calculated value received did not match the calculated CRC of the data.	0x7	No Event		When the LEC bit shows this value, no CAN bus event was detected since this value was written to the LEC field.
Value	Description																																							
0x0	No Error																																							
0x1	Stuff Error																																							
	More than 5 equal bits in a sequence have occurred in a part of a received message where this is not allowed.																																							
0x2	Format Error																																							
	A fixed format part of the received frame has the wrong format.																																							
0x3	ACK Error																																							
	The message transmitted was not acknowledged by another node.																																							
0x4	Bit 1 Error																																							
	When a message is transmitted, the CAN controller monitors the data lines to detect any conflicts. When the arbitration field is transmitted, data conflicts are a part of the arbitration protocol. When other frame fields are transmitted, data conflicts are considered errors.																																							
	A Bit 1 Error indicates that the device wanted to send a High level (logical 1) but the monitored bus value was Low (logical 0).																																							
0x5	Bit 0 Error																																							
	A Bit 0 Error indicates that the device wanted to send a Low level (logical 0), but the monitored bus value was High (logical 1).																																							
	During bus-off recovery, this status is set each time a sequence of 11 High bits has been monitored. By checking for this status, software can monitor the proceeding of the bus-off recovery sequence without any disturbances to the bus.																																							
0x6	CRC Error																																							
	The CRC checksum was incorrect in the received message, indicating that the calculated value received did not match the calculated CRC of the data.																																							
0x7	No Event																																							
	When the LEC bit shows this value, no CAN bus event was detected since this value was written to the LEC field.																																							

Register 3: CAN Error Counter (CANERR), offset 0x008

This register contains the error counter values, which can be used to analyze the cause of an error.

CAN Error Counter (CANERR)

CAN0 base: 0x4004.0000

CAN1 base: 0x4004.1000

Offset 0x008

Type RO, reset 0x0000.0000

	31	30	29	28	27	26	25	24	23	22	21	20	19	18	17	16
	reserved															
Type	RO	RO	RO	RO	RO	RO	RO	RO	RO	RO	RO	RO	RO	RO	RO	RO
Reset	0	0	0	0	0	0	0	0	0	0	0	0	0	0	0	0
	15	14	13	12	11	10	9	8	7	6	5	4	3	2	1	0
	RP	REC						TEC								
Type	RO	RO	RO	RO	RO	RO	RO	RO	RO	RO	RO	RO	RO	RO	RO	RO
Reset	0	0	0	0	0	0	0	0	0	0	0	0	0	0	0	0

Bit/Field	Name	Type	Reset	Description						
31:16	reserved	RO	0x0000	Software should not rely on the value of a reserved bit. To provide compatibility with future products, the value of a reserved bit should be preserved across a read-modify-write operation.						
15	RP	RO	0	Received Error Passive						
				<table border="1"> <thead> <tr> <th>Value</th> <th>Description</th> </tr> </thead> <tbody> <tr> <td>0</td> <td>The Receive Error counter is below the Error Passive level (127 or less).</td> </tr> <tr> <td>1</td> <td>The Receive Error counter has reached the Error Passive level (128 or greater).</td> </tr> </tbody> </table>	Value	Description	0	The Receive Error counter is below the Error Passive level (127 or less).	1	The Receive Error counter has reached the Error Passive level (128 or greater).
Value	Description									
0	The Receive Error counter is below the Error Passive level (127 or less).									
1	The Receive Error counter has reached the Error Passive level (128 or greater).									
14:8	REC	RO	0x00	Receive Error Counter This field contains the state of the receiver error counter (0 to 127).						
7:0	TEC	RO	0x00	Transmit Error Counter This field contains the state of the transmit error counter (0 to 255).						

Register 4: CAN Bit Timing (CANBIT), offset 0x00C

This register is used to program the bit width and bit quantum. Values are programmed to the system clock frequency. This register is write-enabled by setting the `CCE` and `INIT` bits in the `CANCTL` register. See “Bit Time and Bit Rate” on page 1494 for more information.

CAN Bit Timing (CANBIT)

CAN0 base: 0x4004.0000
 CAN1 base: 0x4004.1000
 Offset 0x00C
 Type RW, reset 0x0000.2301

	31	30	29	28	27	26	25	24	23	22	21	20	19	18	17	16
	reserved															
Type	RO	RO	RO	RO	RO	RO	RO	RO	RO	RO	RO	RO	RO	RO	RO	RO
Reset	0	0	0	0	0	0	0	0	0	0	0	0	0	0	0	0
	15	14	13	12	11	10	9	8	7	6	5	4	3	2	1	0
	reserved	TSEG2			TSEG1				SJW		BRP					
Type	RO	RW	RW	RW	RW	RW	RW	RW	RW	RW	RW	RW	RW	RW	RW	RW
Reset	0	0	1	0	0	0	1	1	0	0	0	0	0	0	0	1

Bit/Field	Name	Type	Reset	Description
31:15	reserved	RO	0x0000	Software should not rely on the value of a reserved bit. To provide compatibility with future products, the value of a reserved bit should be preserved across a read-modify-write operation.
14:12	TSEG2	RW	0x2	Time Segment after Sample Point 0x00-0x07: The actual interpretation by the hardware of this value is such that one more than the value programmed here is used. So, for example, the reset value of 0x2 means that 3 (2+1) bit time quanta are defined for <code>Phase2</code> (see Figure 22-4 on page 1495). The bit time quanta is defined by the <code>BRP</code> field.
11:8	TSEG1	RW	0x3	Time Segment Before Sample Point 0x00-0x0F: The actual interpretation by the hardware of this value is such that one more than the value programmed here is used. So, for example, the reset value of 0x3 means that 4 (3+1) bit time quanta are defined for <code>Phase1</code> (see Figure 22-4 on page 1495). The bit time quanta is defined by the <code>BRP</code> field.
7:6	SJW	RW	0x0	(Re)Synchronization Jump Width 0x00-0x03: The actual interpretation by the hardware of this value is such that one more than the value programmed here is used. During the start of frame (SOF), if the CAN controller detects a phase error (misalignment), it can adjust the length of <code>TSEG2</code> or <code>TSEG1</code> by the value in <code>SJW</code> . So the reset value of 0 adjusts the length by 1 bit time quanta.
5:0	BRP	RW	0x1	Baud Rate Prescaler The value by which the oscillator frequency is divided for generating the bit time quanta. The bit time is built up from a multiple of this quantum. 0x00-0x03F: The actual interpretation by the hardware of this value is such that one more than the value programmed here is used. <code>BRP</code> defines the number of CAN clock periods that make up 1 bit time quanta, so the reset value is 2 bit time quanta (1+1). The <code>CANBRPE</code> register can be used to further divide the bit time.

Register 5: CAN Interrupt (CANINT), offset 0x010

This register indicates the source of the interrupt.

If several interrupts are pending, the **CAN Interrupt (CANINT)** register points to the pending interrupt with the highest priority, disregarding the order in which the interrupts occurred. An interrupt remains pending until the CPU has cleared it. If the **INTID** field is not 0x0000 (the default) and the **IE** bit in the **CANCTL** register is set, the interrupt is active. The interrupt line remains active until the **INTID** field is cleared by reading the **CANSTS** register, or until the **IE** bit in the **CANCTL** register is cleared.

Note: Reading the **CAN Status (CANSTS)** register clears the **CAN Interrupt (CANINT)** register, if it is pending.

CAN Interrupt (CANINT)

CAN0 base: 0x4004.0000

CAN1 base: 0x4004.1000

Offset 0x010

Type RO, reset 0x0000.0000

	31	30	29	28	27	26	25	24	23	22	21	20	19	18	17	16
	reserved															
Type	RO	RO	RO	RO	RO	RO	RO	RO	RO	RO	RO	RO	RO	RO	RO	RO
Reset	0	0	0	0	0	0	0	0	0	0	0	0	0	0	0	0
	15	14	13	12	11	10	9	8	7	6	5	4	3	2	1	0
	INTID															
Type	RO	RO	RO	RO	RO	RO	RO	RO	RO	RO	RO	RO	RO	RO	RO	RO
Reset	0	0	0	0	0	0	0	0	0	0	0	0	0	0	0	0

Bit/Field	Name	Type	Reset	Description
31:16	reserved	RO	0x0000	Software should not rely on the value of a reserved bit. To provide compatibility with future products, the value of a reserved bit should be preserved across a read-modify-write operation.
15:0	INTID	RO	0x0000	Interrupt Identifier The number in this field indicates the source of the interrupt.
			Value	Description
			0x0000	No interrupt pending
			0x0001-0x0020	Number of the message object that caused the interrupt
			0x0021-0x7FFF	Reserved
			0x8000	Status Interrupt
			0x8001-0xFFFF	Reserved

Register 6: CAN Test (CANTST), offset 0x014

This register is used for self-test and external pin access. It is write-enabled by setting the `TEST` bit in the `CANCTL` register. Different test functions may be combined, however, CAN transfers are affected if the `TX` bits in this register are not zero.

CAN Test (CANTST)

CAN0 base: 0x4004.0000
 CAN1 base: 0x4004.1000
 Offset 0x014
 Type RW, reset 0x0000.0000

	31	30	29	28	27	26	25	24	23	22	21	20	19	18	17	16
	reserved															
Type	RO	RO	RO	RO	RO	RO	RO	RO	RO	RO	RO	RO	RO	RO	RO	RO
Reset	0	0	0	0	0	0	0	0	0	0	0	0	0	0	0	0
	15	14	13	12	11	10	9	8	7	6	5	4	3	2	1	0
	reserved								RX	TX	LBACK	SILENT	BASIC	reserved		
Type	RO	RO	RO	RO	RO	RO	RO	RO	RO	RW	RW	RW	RW	RW	RO	RO
Reset	0	0	0	0	0	0	0	0	0	0	0	0	0	0	0	0

Bit/Field	Name	Type	Reset	Description										
31:8	reserved	RO	0x0000.00	Software should not rely on the value of a reserved bit. To provide compatibility with future products, the value of a reserved bit should be preserved across a read-modify-write operation.										
7	RX	RO	0	Receive Observation <table border="0"> <tr> <td>Value</td> <td>Description</td> </tr> <tr> <td>0</td> <td>The CANnRx pin is low.</td> </tr> <tr> <td>1</td> <td>The CANnRx pin is high.</td> </tr> </table>	Value	Description	0	The CANnRx pin is low.	1	The CANnRx pin is high.				
Value	Description													
0	The CANnRx pin is low.													
1	The CANnRx pin is high.													
6:5	TX	RW	0x0	Transmit Control Overrides control of the CANnTx pin. <table border="0"> <tr> <td>Value</td> <td>Description</td> </tr> <tr> <td>0x0</td> <td>CAN Module Control CANnTx is controlled by the CAN module; default operation</td> </tr> <tr> <td>0x1</td> <td>Sample Point The sample point is driven on the CANnTx signal. This mode is useful to monitor bit timing.</td> </tr> <tr> <td>0x2</td> <td>Driven Low CANnTx drives a low value. This mode is useful for checking the physical layer of the CAN bus.</td> </tr> <tr> <td>0x3</td> <td>Driven High CANnTx drives a high value. This mode is useful for checking the physical layer of the CAN bus.</td> </tr> </table>	Value	Description	0x0	CAN Module Control CANnTx is controlled by the CAN module; default operation	0x1	Sample Point The sample point is driven on the CANnTx signal. This mode is useful to monitor bit timing.	0x2	Driven Low CANnTx drives a low value. This mode is useful for checking the physical layer of the CAN bus.	0x3	Driven High CANnTx drives a high value. This mode is useful for checking the physical layer of the CAN bus.
Value	Description													
0x0	CAN Module Control CANnTx is controlled by the CAN module; default operation													
0x1	Sample Point The sample point is driven on the CANnTx signal. This mode is useful to monitor bit timing.													
0x2	Driven Low CANnTx drives a low value. This mode is useful for checking the physical layer of the CAN bus.													
0x3	Driven High CANnTx drives a high value. This mode is useful for checking the physical layer of the CAN bus.													

Bit/Field	Name	Type	Reset	Description	
4	LBACK	RW	0	Loopback Mode	
				Value	Description
				0	Loopback mode is disabled.
				1	Loopback mode is enabled. In loopback mode, the data from the transmitter is routed into the receiver. Any data on the receive input is ignored.
3	SILENT	RW	0	Silent Mode	
				Value	Description
				0	Silent mode is disabled.
				1	Silent mode is enabled. In silent mode, the CAN controller does not transmit data but instead monitors the bus. This mode is also known as Bus Monitor mode.
2	BASIC	RW	0	Basic Mode	
				Value	Description
				0	Basic mode is disabled.
				1	Basic mode is enabled. In basic mode, software should use the CANIF1 registers as the transmit buffer and use the CANIF2 registers as the receive buffer.
1:0	reserved	RO	0x0	Software should not rely on the value of a reserved bit. To provide compatibility with future products, the value of a reserved bit should be preserved across a read-modify-write operation.	

Register 7: CAN Baud Rate Prescaler Extension (CANBRPE), offset 0x018

This register is used to further divide the bit time set with the `BRP` bit in the `CANBIT` register. It is write-enabled by setting the `CCE` bit in the `CANCTL` register.

CAN Baud Rate Prescaler Extension (CANBRPE)

CAN0 base: 0x4004.0000
 CAN1 base: 0x4004.1000
 Offset 0x018
 Type RW, reset 0x0000.0000

	31	30	29	28	27	26	25	24	23	22	21	20	19	18	17	16
	reserved															
Type	RO	RO	RO	RO	RO	RO	RO	RO	RO	RO	RO	RO	RO	RO	RO	RO
Reset	0	0	0	0	0	0	0	0	0	0	0	0	0	0	0	0
	15	14	13	12	11	10	9	8	7	6	5	4	3	2	1	0
	reserved												BRPE			
Type	RO	RO	RO	RO	RO	RO	RO	RO	RO	RO	RO	RO	RW	RW	RW	RW
Reset	0	0	0	0	0	0	0	0	0	0	0	0	0	0	0	0

Bit/Field	Name	Type	Reset	Description
31:4	reserved	RO	0x0000.000	Software should not rely on the value of a reserved bit. To provide compatibility with future products, the value of a reserved bit should be preserved across a read-modify-write operation.
3:0	BRPE	RW	0x0	Baud Rate Prescaler Extension 0x00-0x0F: Extend the <code>BRP</code> bit in the <code>CANBIT</code> register to values up to 1023. The actual interpretation by the hardware is one more than the value programmed by <code>BRPE</code> (MSBs) and <code>BRP</code> (LSBs).

Register 8: CAN IF1 Command Request (CANIF1CRQ), offset 0x020**Register 9: CAN IF2 Command Request (CANIF2CRQ), offset 0x080**

A message transfer is started as soon as there is a write of the message object number to the MNUM field when the TXRQST bit in the CANIF1MCTL register is set. With this write operation, the BUSY bit is automatically set to indicate that a transfer between the CAN Interface Registers and the internal message RAM is in progress. After a wait time of 3 to 6 CAN_CLK periods, the transfer between the interface register and the message RAM completes, which then clears the BUSY bit.

CAN IFn Command Request (CANIFnCRQ)

CAN0 base: 0x4004.0000
 CAN1 base: 0x4004.1000
 Offset 0x020
 Type RW, reset 0x0000.0001

	31	30	29	28	27	26	25	24	23	22	21	20	19	18	17	16
	reserved															
Type	RO	RO	RO	RO	RO	RO	RO	RO	RO	RO	RO	RO	RO	RO	RO	RO
Reset	0	0	0	0	0	0	0	0	0	0	0	0	0	0	0	0
	15	14	13	12	11	10	9	8	7	6	5	4	3	2	1	0
	BUSY	reserved									MNUM					
Type	RO	RO	RO	RO	RO	RO	RO	RO	RO	RO	RW	RW	RW	RW	RW	RW
Reset	0	0	0	0	0	0	0	0	0	0	0	0	0	0	0	1

Bit/Field	Name	Type	Reset	Description														
31:16	reserved	RO	0x0000	Software should not rely on the value of a reserved bit. To provide compatibility with future products, the value of a reserved bit should be preserved across a read-modify-write operation.														
15	BUSY	RO	0	Busy Flag														
				<table border="0"> <tr> <td style="padding-right: 20px;">Value</td> <td>Description</td> </tr> <tr> <td>0</td> <td>This bit is cleared when read/write action has finished.</td> </tr> <tr> <td>1</td> <td>This bit is set when a write occurs to the message number in this register.</td> </tr> </table>	Value	Description	0	This bit is cleared when read/write action has finished.	1	This bit is set when a write occurs to the message number in this register.								
Value	Description																	
0	This bit is cleared when read/write action has finished.																	
1	This bit is set when a write occurs to the message number in this register.																	
14:6	reserved	RO	0x00	Software should not rely on the value of a reserved bit. To provide compatibility with future products, the value of a reserved bit should be preserved across a read-modify-write operation.														
5:0	MNUM	RW	0x01	<p>Message Number</p> <p>Selects one of the 32 message objects in the message RAM for data transfer. The message objects are numbered from 1 to 32.</p> <table border="0"> <tr> <td style="padding-right: 20px;">Value</td> <td>Description</td> </tr> <tr> <td>0x00</td> <td>Reserved</td> </tr> <tr> <td></td> <td>0 is not a valid message number; it is interpreted as 0x20, or object 32.</td> </tr> <tr> <td>0x01-0x20</td> <td>Message Number</td> </tr> <tr> <td></td> <td>Indicates specified message object 1 to 32.</td> </tr> <tr> <td>0x21-0x3F</td> <td>Reserved</td> </tr> <tr> <td></td> <td>Not a valid message number; values are shifted and it is interpreted as 0x01-0x1F.</td> </tr> </table>	Value	Description	0x00	Reserved		0 is not a valid message number; it is interpreted as 0x20, or object 32.	0x01-0x20	Message Number		Indicates specified message object 1 to 32.	0x21-0x3F	Reserved		Not a valid message number; values are shifted and it is interpreted as 0x01-0x1F.
Value	Description																	
0x00	Reserved																	
	0 is not a valid message number; it is interpreted as 0x20, or object 32.																	
0x01-0x20	Message Number																	
	Indicates specified message object 1 to 32.																	
0x21-0x3F	Reserved																	
	Not a valid message number; values are shifted and it is interpreted as 0x01-0x1F.																	

Register 10: CAN IF1 Command Mask (CANIF1CMSK), offset 0x024

Register 11: CAN IF2 Command Mask (CANIF2CMSK), offset 0x084

Reading the Command Mask registers provides status for various functions. Writing to the Command Mask registers specifies the transfer direction and selects which buffer registers are the source or target of the data transfer.

Note that when a read from the message object buffer occurs when the WRNRD bit is clear and the CLRINTPND and/or NEWDAT bits are set, the interrupt pending and/or new data flags in the message object buffer are cleared.

CAN IFn Command Mask (CANIFnCMSK)

CAN0 base: 0x4004.0000
 CAN1 base: 0x4004.1000
 Offset 0x024
 Type RW, reset 0x0000.0000

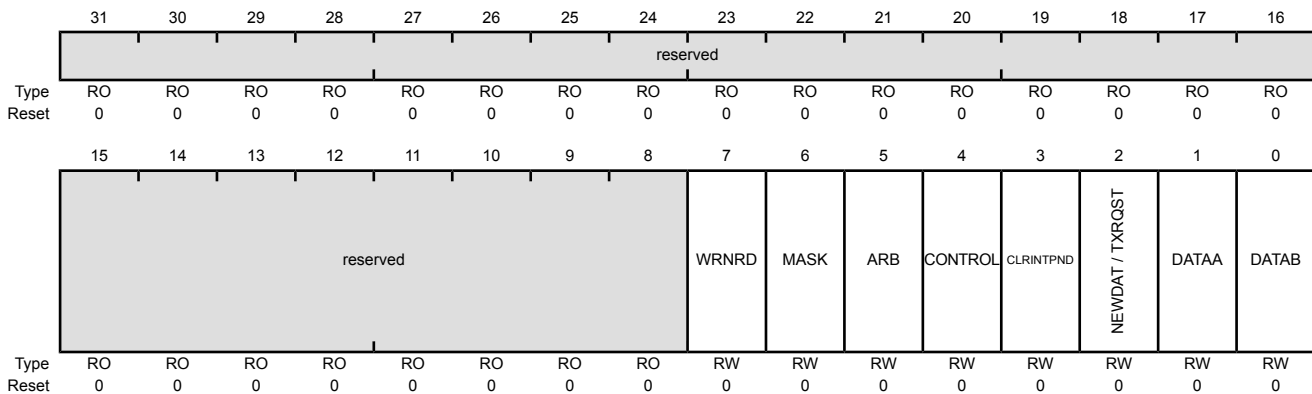

Bit/Field	Name	Type	Reset	Description						
31:8	reserved	RO	0x0000.00	Software should not rely on the value of a reserved bit. To provide compatibility with future products, the value of a reserved bit should be preserved across a read-modify-write operation.						
7	WRNRD	RW	0	Write, Not Read						
				<table border="1"> <thead> <tr> <th>Value</th> <th>Description</th> </tr> </thead> <tbody> <tr> <td>0</td> <td>Transfer the data in the CAN message object specified by the MNUM field in the CANIFnCRQ register into the CANIFn registers.</td> </tr> <tr> <td>1</td> <td>Transfer the data in the CANIFn registers to the CAN message object specified by the MNUM field in the CAN Command Request (CANIFnCRQ).</td> </tr> </tbody> </table> <p>Note: Interrupt pending and new data conditions in the message buffer can be cleared by reading from the buffer (WRNRD = 0) when the CLRINTPND and/or NEWDAT bits are set.</p>	Value	Description	0	Transfer the data in the CAN message object specified by the MNUM field in the CANIFnCRQ register into the CANIFn registers.	1	Transfer the data in the CANIFn registers to the CAN message object specified by the MNUM field in the CAN Command Request (CANIFnCRQ).
Value	Description									
0	Transfer the data in the CAN message object specified by the MNUM field in the CANIFnCRQ register into the CANIFn registers.									
1	Transfer the data in the CANIFn registers to the CAN message object specified by the MNUM field in the CAN Command Request (CANIFnCRQ).									
6	MASK	RW	0	Access Mask Bits						
				<table border="1"> <thead> <tr> <th>Value</th> <th>Description</th> </tr> </thead> <tbody> <tr> <td>0</td> <td>Mask bits unchanged.</td> </tr> <tr> <td>1</td> <td>Transfer IDMASK + DIR + MXTD of the message object into the Interface registers.</td> </tr> </tbody> </table>	Value	Description	0	Mask bits unchanged.	1	Transfer IDMASK + DIR + MXTD of the message object into the Interface registers.
Value	Description									
0	Mask bits unchanged.									
1	Transfer IDMASK + DIR + MXTD of the message object into the Interface registers.									

Bit/Field	Name	Type	Reset	Description		
5	ARB	RW	0	Access Arbitration Bits		
				Value	Description	
				0	Arbitration bits unchanged.	
1	Transfer ID + DIR + XTD + MSGVAL of the message object into the Interface registers.					
4	CONTROL	RW	0	Access Control Bits		
				Value	Description	
				0	Control bits unchanged.	
1	Transfer control bits from the CANIFnMCTL register into the Interface registers.					
3	CLRINTPND	RW	0	Clear Interrupt Pending Bit		
				The function of this bit depends on the configuration of the WRNRD bit.		
				Value	Description	
0	If WRNRD is clear, the interrupt pending status is transferred from the message buffer into the CANIFnMCTL register. If WRNRD is set, the INTPND bit in the message object remains unchanged.					
1	If WRNRD is clear, the interrupt pending status is cleared in the message buffer. Note the value of this bit that is transferred to the CANIFnMCTL register always reflects the status of the bits before clearing. If WRNRD is set, the INTPND bit is cleared in the message object.					
2	NEWDAT / TXRQST	RW	0	NEWDAT / TXRQST Bit		
				The function of this bit depends on the configuration of the WRNRD bit.		
				Value	Description	
0	If WRNRD is clear, the value of the new data status is transferred from the message buffer into the CANIFnMCTL register. If WRNRD is set, a transmission is not requested.					
1	If WRNRD is clear, the new data status is cleared in the message buffer. Note the value of this bit that is transferred to the CANIFnMCTL register always reflects the status of the bits before clearing. If WRNRD is set, a transmission is requested. Note that when this bit is set, the TXRQST bit in the CANIFnMCTL register is ignored.					

Bit/Field	Name	Type	Reset	Description						
1	DATAA	RW	0	<p>Access Data Byte 0 to 3</p> <p>The function of this bit depends on the configuration of the WRNRD bit.</p> <table><thead><tr><th>Value</th><th>Description</th></tr></thead><tbody><tr><td>0</td><td>Data bytes 0-3 are unchanged.</td></tr><tr><td>1</td><td>If WRNRD is clear, transfer data bytes 0-3 in CANIFnDA1 and CANIFnDA2 to the message object. If WRNRD is set, transfer data bytes 0-3 in message object to CANIFnDA1 and CANIFnDA2.</td></tr></tbody></table>	Value	Description	0	Data bytes 0-3 are unchanged.	1	If WRNRD is clear, transfer data bytes 0-3 in CANIFnDA1 and CANIFnDA2 to the message object. If WRNRD is set, transfer data bytes 0-3 in message object to CANIFnDA1 and CANIFnDA2 .
Value	Description									
0	Data bytes 0-3 are unchanged.									
1	If WRNRD is clear, transfer data bytes 0-3 in CANIFnDA1 and CANIFnDA2 to the message object. If WRNRD is set, transfer data bytes 0-3 in message object to CANIFnDA1 and CANIFnDA2 .									
0	DATAB	RW	0	<p>Access Data Byte 4 to 7</p> <p>The function of this bit depends on the configuration of the WRNRD bit as follows:</p> <table><thead><tr><th>Value</th><th>Description</th></tr></thead><tbody><tr><td>0</td><td>Data bytes 4-7 are unchanged.</td></tr><tr><td>1</td><td>If WRNRD is clear, transfer data bytes 4-7 in CANIFnDA1 and CANIFnDA2 to the message object. If WRNRD is set, transfer data bytes 4-7 in message object to CANIFnDA1 and CANIFnDA2.</td></tr></tbody></table>	Value	Description	0	Data bytes 4-7 are unchanged.	1	If WRNRD is clear, transfer data bytes 4-7 in CANIFnDA1 and CANIFnDA2 to the message object. If WRNRD is set, transfer data bytes 4-7 in message object to CANIFnDA1 and CANIFnDA2 .
Value	Description									
0	Data bytes 4-7 are unchanged.									
1	If WRNRD is clear, transfer data bytes 4-7 in CANIFnDA1 and CANIFnDA2 to the message object. If WRNRD is set, transfer data bytes 4-7 in message object to CANIFnDA1 and CANIFnDA2 .									

Register 12: CAN IF1 Mask 1 (CANIF1MSK1), offset 0x028**Register 13: CAN IF2 Mask 1 (CANIF2MSK1), offset 0x088**

The mask information provided in this register accompanies the data (**CANIFnDAn**), arbitration information (**CANIFnARBn**), and control information (**CANIFnMCTL**) to the message object in the message RAM. The mask is used with the **ID** bit in the **CANIFnARBn** register for acceptance filtering. Additional mask information is contained in the **CANIFnMSK2** register.

CAN IFn Mask 1 (CANIFnMSK1)

CAN0 base: 0x4004.0000
 CAN1 base: 0x4004.1000
 Offset 0x028
 Type RW, reset 0x0000.FFFF

	31	30	29	28	27	26	25	24	23	22	21	20	19	18	17	16
	reserved															
Type	RO	RO	RO	RO	RO	RO	RO	RO	RO	RO	RO	RO	RO	RO	RO	RO
Reset	0	0	0	0	0	0	0	0	0	0	0	0	0	0	0	0
	15	14	13	12	11	10	9	8	7	6	5	4	3	2	1	0
	MSK															
Type	RW	RW	RW	RW	RW	RW	RW	RW	RW	RW	RW	RW	RW	RW	RW	RW
Reset	1	1	1	1	1	1	1	1	1	1	1	1	1	1	1	1

Bit/Field	Name	Type	Reset	Description
31:16	reserved	RO	0x0000	Software should not rely on the value of a reserved bit. To provide compatibility with future products, the value of a reserved bit should be preserved across a read-modify-write operation.
15:0	MSK	RW	0xFFFF	Identifier Mask When using a 29-bit identifier, these bits are used for bits [15:0] of the ID. The MSK field in the CANIFnMSK2 register are used for bits [28:16] of the ID. When using an 11-bit identifier, these bits are ignored.
	Value	Description		
	0	The corresponding identifier field (ID) in the message object cannot inhibit the match in acceptance filtering.		
	1	The corresponding identifier field (ID) is used for acceptance filtering.		

Register 14: CAN IF1 Mask 2 (CANIF1MSK2), offset 0x02C

Register 15: CAN IF2 Mask 2 (CANIF2MSK2), offset 0x08C

This register holds extended mask information that accompanies the **CANIFnMSK1** register.

CAN IFn Mask 2 (CANIFnMSK2)

CAN0 base: 0x4004.0000
 CAN1 base: 0x4004.1000
 Offset 0x02C
 Type RW, reset 0x0000.FFFF

	31	30	29	28	27	26	25	24	23	22	21	20	19	18	17	16
	reserved															
Type	RO	RO	RO	RO	RO	RO	RO	RO	RO	RO	RO	RO	RO	RO	RO	RO
Reset	0	0	0	0	0	0	0	0	0	0	0	0	0	0	0	0
	15	14	13	12	11	10	9	8	7	6	5	4	3	2	1	0
	MXTD	MDIR	reserved													
Type	RW	RW	RO	RW	RW	RW	RW	RW	RW	RW	RW	RW	RW	RW	RW	RW
Reset	1	1	1	0	0	0	0	0	1	1	1	1	1	1	1	1

Bit/Field	Name	Type	Reset	Description						
31:16	reserved	RO	0x0000	Software should not rely on the value of a reserved bit. To provide compatibility with future products, the value of a reserved bit should be preserved across a read-modify-write operation.						
15	MXTD	RW	1	Mask Extended Identifier <table border="0"> <tr> <td>Value</td> <td>Description</td> </tr> <tr> <td>0</td> <td>The extended identifier bit (<i>XTD</i> in the CANIFnARB2 register) has no effect on the acceptance filtering.</td> </tr> <tr> <td>1</td> <td>The extended identifier bit <i>XTD</i> is used for acceptance filtering.</td> </tr> </table>	Value	Description	0	The extended identifier bit (<i>XTD</i> in the CANIFnARB2 register) has no effect on the acceptance filtering.	1	The extended identifier bit <i>XTD</i> is used for acceptance filtering.
Value	Description									
0	The extended identifier bit (<i>XTD</i> in the CANIFnARB2 register) has no effect on the acceptance filtering.									
1	The extended identifier bit <i>XTD</i> is used for acceptance filtering.									
14	MDIR	RW	1	Mask Message Direction <table border="0"> <tr> <td>Value</td> <td>Description</td> </tr> <tr> <td>0</td> <td>The message direction bit (<i>DIR</i> in the CANIFnARB2 register) has no effect for acceptance filtering.</td> </tr> <tr> <td>1</td> <td>The message direction bit <i>DIR</i> is used for acceptance filtering.</td> </tr> </table>	Value	Description	0	The message direction bit (<i>DIR</i> in the CANIFnARB2 register) has no effect for acceptance filtering.	1	The message direction bit <i>DIR</i> is used for acceptance filtering.
Value	Description									
0	The message direction bit (<i>DIR</i> in the CANIFnARB2 register) has no effect for acceptance filtering.									
1	The message direction bit <i>DIR</i> is used for acceptance filtering.									
13	reserved	RO	1	Software should not rely on the value of a reserved bit. To provide compatibility with future products, the value of a reserved bit should be preserved across a read-modify-write operation.						

Bit/Field	Name	Type	Reset	Description						
12:0	MSK	RW	0xFF	<p>Identifier Mask</p> <p>When using a 29-bit identifier, these bits are used for bits [28:16] of the ID. The <code>MSK</code> field in the CANIFnMSK1 register are used for bits [15:0] of the ID. When using an 11-bit identifier, <code>MSK[12:2]</code> are used for bits [10:0] of the ID.</p> <table><thead><tr><th>Value</th><th>Description</th></tr></thead><tbody><tr><td>0</td><td>The corresponding identifier field (<code>ID</code>) in the message object cannot inhibit the match in acceptance filtering.</td></tr><tr><td>1</td><td>The corresponding identifier field (<code>ID</code>) is used for acceptance filtering.</td></tr></tbody></table>	Value	Description	0	The corresponding identifier field (<code>ID</code>) in the message object cannot inhibit the match in acceptance filtering.	1	The corresponding identifier field (<code>ID</code>) is used for acceptance filtering.
Value	Description									
0	The corresponding identifier field (<code>ID</code>) in the message object cannot inhibit the match in acceptance filtering.									
1	The corresponding identifier field (<code>ID</code>) is used for acceptance filtering.									

Register 16: CAN IF1 Arbitration 1 (CANIF1ARB1), offset 0x030

Register 17: CAN IF2 Arbitration 1 (CANIF2ARB1), offset 0x090

These registers hold the identifiers for acceptance filtering.

CAN IFn Arbitration 1 (CANIFnARB1)

CAN0 base: 0x4004.0000
 CAN1 base: 0x4004.1000
 Offset 0x030
 Type RW, reset 0x0000.0000

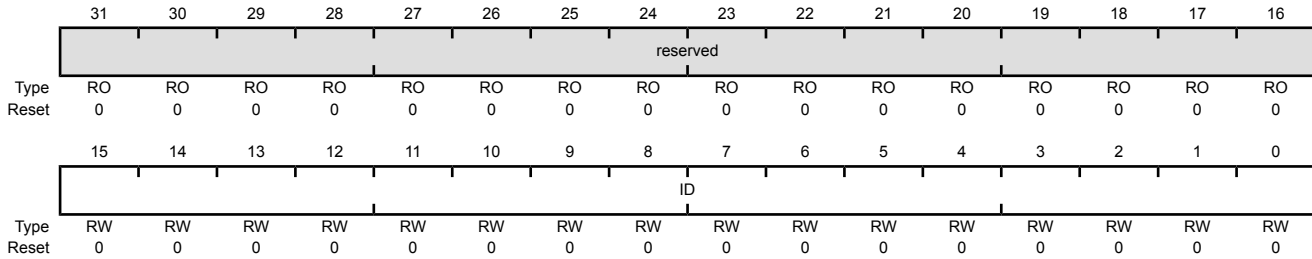

Bit/Field	Name	Type	Reset	Description
31:16	reserved	RO	0x0000	Software should not rely on the value of a reserved bit. To provide compatibility with future products, the value of a reserved bit should be preserved across a read-modify-write operation.
15:0	ID	RW	0x0000	<p>Message Identifier</p> <p>This bit field is used with the ID field in the CANIFnARB2 register to create the message identifier.</p> <p>When using a 29-bit identifier, bits 15:0 of the CANIFnARB1 register are [15:0] of the ID, while bits 12:0 of the CANIFnARB2 register are [28:16] of the ID.</p> <p>When using an 11-bit identifier, these bits are not used.</p>

Register 18: CAN IF1 Arbitration 2 (CANIF1ARB2), offset 0x034**Register 19: CAN IF2 Arbitration 2 (CANIF2ARB2), offset 0x094**

These registers hold information for acceptance filtering.

CAN IFn Arbitration 2 (CANIFnARB2)

CAN0 base: 0x4004.0000

CAN1 base: 0x4004.1000

Offset 0x034

Type RW, reset 0x0000.0000

	31	30	29	28	27	26	25	24	23	22	21	20	19	18	17	16
	reserved															
Type	RO	RO	RO	RO	RO	RO	RO	RO	RO	RO	RO	RO	RO	RO	RO	RO
Reset	0	0	0	0	0	0	0	0	0	0	0	0	0	0	0	0
	15	14	13	12	11	10	9	8	7	6	5	4	3	2	1	0
	MSGVAL	XTD	DIR							ID						
Type	RW	RW	RW	RW	RW	RW	RW	RW	RW	RW	RW	RW	RW	RW	RW	RW
Reset	0	0	0	0	0	0	0	0	0	0	0	0	0	0	0	0

Bit/Field	Name	Type	Reset	Description
31:16	reserved	RO	0x0000	Software should not rely on the value of a reserved bit. To provide compatibility with future products, the value of a reserved bit should be preserved across a read-modify-write operation.

15	MSGVAL	RW	0	Message Valid
----	--------	----	---	---------------

Value	Description
0	The message object is ignored by the message handler.
1	The message object is configured and ready to be considered by the message handler within the CAN controller.

All unused message objects should have this bit cleared during initialization and before clearing the `INIT` bit in the `CANCTL` register. The `MSGVAL` bit must also be cleared before any of the following bits are modified or if the message object is no longer required: the `ID` fields in the `CANIFnARBn` registers, the `XTD` and `DIR` bits in the `CANIFnARB2` register, or the `DLC` field in the `CANIFnMCTL` register.

14	XTD	RW	0	Extended Identifier
----	-----	----	---	---------------------

Value	Description
0	An 11-bit Standard Identifier is used for this message object.
1	A 29-bit Extended Identifier is used for this message object.

Bit/Field	Name	Type	Reset	Description						
13	DIR	RW	0	<p>Message Direction</p> <table border="1"> <thead> <tr> <th>Value</th> <th>Description</th> </tr> </thead> <tbody> <tr> <td>0</td> <td>Receive. When the <code>TXRQST</code> bit in the <code>CANIFnMCTL</code> register is set, a remote frame with the identifier of this message object is received. On reception of a data frame with matching identifier, that message is stored in this message object.</td> </tr> <tr> <td>1</td> <td>Transmit. When the <code>TXRQST</code> bit in the <code>CANIFnMCTL</code> register is set, the respective message object is transmitted as a data frame. On reception of a remote frame with matching identifier, the <code>TXRQST</code> bit of this message object is set (if <code>RMTEN=1</code>).</td> </tr> </tbody> </table>	Value	Description	0	Receive. When the <code>TXRQST</code> bit in the <code>CANIFnMCTL</code> register is set, a remote frame with the identifier of this message object is received. On reception of a data frame with matching identifier, that message is stored in this message object.	1	Transmit. When the <code>TXRQST</code> bit in the <code>CANIFnMCTL</code> register is set, the respective message object is transmitted as a data frame. On reception of a remote frame with matching identifier, the <code>TXRQST</code> bit of this message object is set (if <code>RMTEN=1</code>).
Value	Description									
0	Receive. When the <code>TXRQST</code> bit in the <code>CANIFnMCTL</code> register is set, a remote frame with the identifier of this message object is received. On reception of a data frame with matching identifier, that message is stored in this message object.									
1	Transmit. When the <code>TXRQST</code> bit in the <code>CANIFnMCTL</code> register is set, the respective message object is transmitted as a data frame. On reception of a remote frame with matching identifier, the <code>TXRQST</code> bit of this message object is set (if <code>RMTEN=1</code>).									
12:0	ID	RW	0x000	<p>Message Identifier</p> <p>This bit field is used with the <code>ID</code> field in the <code>CANIFnARB2</code> register to create the message identifier.</p> <p>When using a 29-bit identifier, <code>ID[15:0]</code> of the <code>CANIFnARB1</code> register are [15:0] of the ID, while these bits, <code>ID[12:0]</code>, are [28:16] of the ID.</p> <p>When using an 11-bit identifier, <code>ID[12:2]</code> are used for bits [10:0] of the ID. The <code>ID</code> field in the <code>CANIFnARB1</code> register is ignored.</p>						

Register 20: CAN IF1 Message Control (CANIF1MCTL), offset 0x038**Register 21: CAN IF2 Message Control (CANIF2MCTL), offset 0x098**

This register holds the control information associated with the message object to be sent to the Message RAM.

CAN IFn Message Control (CANIFnMCTL)

CAN0 base: 0x4004.0000

CAN1 base: 0x4004.1000

Offset 0x038

Type RW, reset 0x0000.0000

	31	30	29	28	27	26	25	24	23	22	21	20	19	18	17	16
	reserved															
Type	RO	RO	RO	RO	RO	RO	RO	RO	RO	RO	RO	RO	RO	RO	RO	RO
Reset	0	0	0	0	0	0	0	0	0	0	0	0	0	0	0	0
	15	14	13	12	11	10	9	8	7	6	5	4	3	2	1	0
	NEWDAT	MSGLST	INTPND	UMASK	TXIE	RXIE	RMTEN	TXRQST	EOB	reserved			DLC			
Type	RW	RW	RW	RW	RW	RW	RW	RW	RW	RO	RO	RO	RW	RW	RW	RW
Reset	0	0	0	0	0	0	0	0	0	0	0	0	0	0	0	0

Bit/Field	Name	Type	Reset	Description						
31:16	reserved	RO	0x0000	Software should not rely on the value of a reserved bit. To provide compatibility with future products, the value of a reserved bit should be preserved across a read-modify-write operation.						
15	NEWDAT	RW	0	New Data <table border="1" style="margin-left: 20px;"> <thead> <tr> <th>Value</th> <th>Description</th> </tr> </thead> <tbody> <tr> <td>0</td> <td>No new data has been written into the data portion of this message object by the message handler since the last time this flag was cleared by the CPU.</td> </tr> <tr> <td>1</td> <td>The message handler or the CPU has written new data into the data portion of this message object.</td> </tr> </tbody> </table>	Value	Description	0	No new data has been written into the data portion of this message object by the message handler since the last time this flag was cleared by the CPU.	1	The message handler or the CPU has written new data into the data portion of this message object.
Value	Description									
0	No new data has been written into the data portion of this message object by the message handler since the last time this flag was cleared by the CPU.									
1	The message handler or the CPU has written new data into the data portion of this message object.									
14	MSGLST	RW	0	Message Lost <table border="1" style="margin-left: 20px;"> <thead> <tr> <th>Value</th> <th>Description</th> </tr> </thead> <tbody> <tr> <td>0</td> <td>No message was lost since the last time this bit was cleared by the CPU.</td> </tr> <tr> <td>1</td> <td>The message handler stored a new message into this object when NEWDAT was set; the CPU has lost a message.</td> </tr> </tbody> </table> <p>This bit is only valid for message objects when the DIR bit in the CANIFnARB2 register is clear (receive).</p>	Value	Description	0	No message was lost since the last time this bit was cleared by the CPU.	1	The message handler stored a new message into this object when NEWDAT was set; the CPU has lost a message.
Value	Description									
0	No message was lost since the last time this bit was cleared by the CPU.									
1	The message handler stored a new message into this object when NEWDAT was set; the CPU has lost a message.									
13	INTPND	RW	0	Interrupt Pending <table border="1" style="margin-left: 20px;"> <thead> <tr> <th>Value</th> <th>Description</th> </tr> </thead> <tbody> <tr> <td>0</td> <td>This message object is not the source of an interrupt.</td> </tr> <tr> <td>1</td> <td>This message object is the source of an interrupt. The interrupt identifier in the CANINT register points to this message object if there is not another interrupt source with a higher priority.</td> </tr> </tbody> </table>	Value	Description	0	This message object is not the source of an interrupt.	1	This message object is the source of an interrupt. The interrupt identifier in the CANINT register points to this message object if there is not another interrupt source with a higher priority.
Value	Description									
0	This message object is not the source of an interrupt.									
1	This message object is the source of an interrupt. The interrupt identifier in the CANINT register points to this message object if there is not another interrupt source with a higher priority.									

Bit/Field	Name	Type	Reset	Description	
12	UMASK	RW	0	Use Acceptance Mask	
				Value	Description
				0	Mask is ignored.
				1	Use mask (MSK, MXTD, and MDIR bits in the CANIFnMSKn registers) for acceptance filtering.
11	TXIE	RW	0	Transmit Interrupt Enable	
				Value	Description
				0	The INTPND bit in the CANIFnMCTL register is unchanged after a successful transmission of a frame.
				1	The INTPND bit in the CANIFnMCTL register is set after a successful transmission of a frame.
10	RXIE	RW	0	Receive Interrupt Enable	
				Value	Description
				0	The INTPND bit in the CANIFnMCTL register is unchanged after a successful reception of a frame.
				1	The INTPND bit in the CANIFnMCTL register is set after a successful reception of a frame.
9	RMTEN	RW	0	Remote Enable	
				Value	Description
				0	At the reception of a remote frame, the TXRQST bit in the CANIFnMCTL register is left unchanged.
				1	At the reception of a remote frame, the TXRQST bit in the CANIFnMCTL register is set.
8	TXRQST	RW	0	Transmit Request	
				Value	Description
				0	This message object is not waiting for transmission.
				1	The transmission of this message object is requested and is not yet done.
				Note:	If the WRNRD and TXRQST bits in the CANIFnCMSK register are set, this bit is ignored.

Bit/Field	Name	Type	Reset	Description						
7	EOB	RW	0	<p>End of Buffer</p> <table border="1"> <thead> <tr> <th>Value</th> <th>Description</th> </tr> </thead> <tbody> <tr> <td>0</td> <td>Message object belongs to a FIFO Buffer and is not the last message object of that FIFO Buffer.</td> </tr> <tr> <td>1</td> <td>Single message object or last message object of a FIFO Buffer.</td> </tr> </tbody> </table> <p>This bit is used to concatenate two or more message objects (up to 32) to build a FIFO buffer. For a single message object (thus not belonging to a FIFO buffer), this bit must be set.</p>	Value	Description	0	Message object belongs to a FIFO Buffer and is not the last message object of that FIFO Buffer.	1	Single message object or last message object of a FIFO Buffer.
Value	Description									
0	Message object belongs to a FIFO Buffer and is not the last message object of that FIFO Buffer.									
1	Single message object or last message object of a FIFO Buffer.									
6:4	reserved	RO	0x0	Software should not rely on the value of a reserved bit. To provide compatibility with future products, the value of a reserved bit should be preserved across a read-modify-write operation.						
3:0	DLC	RW	0x0	<p>Data Length Code</p> <table border="1"> <thead> <tr> <th>Value</th> <th>Description</th> </tr> </thead> <tbody> <tr> <td>0x0-0x8</td> <td>Specifies the number of bytes in the data frame.</td> </tr> <tr> <td>0x9-0xF</td> <td>Defaults to a data frame with 8 bytes.</td> </tr> </tbody> </table> <p>The DLC field in the CANIFnMCTL register of a message object must be defined the same as in all the corresponding objects with the same identifier at other nodes. When the message handler stores a data frame, it writes DLC to the value given by the received message.</p>	Value	Description	0x0-0x8	Specifies the number of bytes in the data frame.	0x9-0xF	Defaults to a data frame with 8 bytes.
Value	Description									
0x0-0x8	Specifies the number of bytes in the data frame.									
0x9-0xF	Defaults to a data frame with 8 bytes.									

Register 22: CAN IF1 Data A1 (CANIF1DA1), offset 0x03C

Register 23: CAN IF1 Data A2 (CANIF1DA2), offset 0x040

Register 24: CAN IF1 Data B1 (CANIF1DB1), offset 0x044

Register 25: CAN IF1 Data B2 (CANIF1DB2), offset 0x048

Register 26: CAN IF2 Data A1 (CANIF2DA1), offset 0x09C

Register 27: CAN IF2 Data A2 (CANIF2DA2), offset 0x0A0

Register 28: CAN IF2 Data B1 (CANIF2DB1), offset 0x0A4

Register 29: CAN IF2 Data B2 (CANIF2DB2), offset 0x0A8

These registers contain the data to be sent or that has been received. In a CAN data frame, data byte 0 is the first byte to be transmitted or received and data byte 7 is the last byte to be transmitted or received. In CAN's serial bit stream, the MSB of each byte is transmitted first.

CAN IFn Data nn (CANIFnDnn)

CAN0 base: 0x4004.0000
 CAN1 base: 0x4004.1000
 Offset 0x03C
 Type RW, reset 0x0000.0000

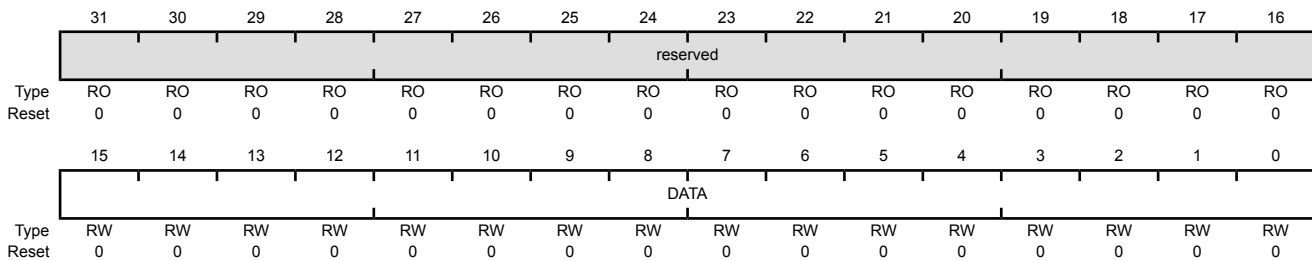

Bit/Field	Name	Type	Reset	Description
31:16	reserved	RO	0x0000	Software should not rely on the value of a reserved bit. To provide compatibility with future products, the value of a reserved bit should be preserved across a read-modify-write operation.
15:0	DATA	RW	0x0000	Data The CANIFnDA1 registers contain data bytes 1 and 0; CANIFnDA2 data bytes 3 and 2; CANIFnDB1 data bytes 5 and 4; and CANIFnDB2 data bytes 7 and 6.

Register 30: CAN Transmission Request 1 (CANTXRQ1), offset 0x100**Register 31: CAN Transmission Request 2 (CANTXRQ2), offset 0x104**

The **CANTXRQ1** and **CANTXRQ2** registers hold the **TXRQST** bits of the 32 message objects. By reading out these bits, the CPU can check which message object has a transmission request pending. The **TXRQST** bit of a specific message object can be changed by three sources: (1) the CPU via the **CANIFnMCTL** register, (2) the message handler state machine after the reception of a remote frame, or (3) the message handler state machine after a successful transmission.

The **CANTXRQ1** register contains the **TXRQST** bits of the first 16 message objects in the message RAM; the **CANTXRQ2** register contains the **TXRQST** bits of the second 16 message objects.

CAN Transmission Request n (CANTXRQn)

CAN0 base: 0x4004.0000
 CAN1 base: 0x4004.1000
 Offset 0x100
 Type RO, reset 0x0000.0000

	31	30	29	28	27	26	25	24	23	22	21	20	19	18	17	16
	reserved															
Type	RO	RO	RO	RO	RO	RO	RO	RO	RO	RO	RO	RO	RO	RO	RO	RO
Reset	0	0	0	0	0	0	0	0	0	0	0	0	0	0	0	0
	15	14	13	12	11	10	9	8	7	6	5	4	3	2	1	0
	TXRQST															
Type	RO	RO	RO	RO	RO	RO	RO	RO	RO	RO	RO	RO	RO	RO	RO	RO
Reset	0	0	0	0	0	0	0	0	0	0	0	0	0	0	0	0

Bit/Field	Name	Type	Reset	Description
31:16	reserved	RO	0x0000	Software should not rely on the value of a reserved bit. To provide compatibility with future products, the value of a reserved bit should be preserved across a read-modify-write operation.
15:0	TXRQST	RO	0x0000	Transmission Request Bits
	Value	Description		
	0	The corresponding message object is not waiting for transmission.		
	1	The transmission of the corresponding message object is requested and is not yet done.		

Register 32: CAN New Data 1 (CANNWDA1), offset 0x120

Register 33: CAN New Data 2 (CANNWDA2), offset 0x124

The **CANNWDA1** and **CANNWDA2** registers hold the **NEWDAT** bits of the 32 message objects. By reading these bits, the CPU can check which message object has its data portion updated. The **NEWDAT** bit of a specific message object can be changed by three sources: (1) the CPU via the **CANIFnMCTL** register, (2) the message handler state machine after the reception of a data frame, or (3) the message handler state machine after a successful transmission.

The **CANNWDA1** register contains the **NEWDAT** bits of the first 16 message objects in the message RAM; the **CANNWDA2** register contains the **NEWDAT** bits of the second 16 message objects.

CAN New Data n (CANNWDAn)

CAN0 base: 0x4004.0000
 CAN1 base: 0x4004.1000
 Offset 0x120
 Type RO, reset 0x0000.0000



Bit/Field	Name	Type	Reset	Description
31:16	reserved	RO	0x0000	Software should not rely on the value of a reserved bit. To provide compatibility with future products, the value of a reserved bit should be preserved across a read-modify-write operation.
15:0	NEWDAT	RO	0x0000	New Data Bits
				Value Description
				0 No new data has been written into the data portion of the corresponding message object by the message handler since the last time this flag was cleared by the CPU.
				1 The message handler or the CPU has written new data into the data portion of the corresponding message object.

Register 34: CAN Message 1 Interrupt Pending (CANMSG1INT), offset 0x140**Register 35: CAN Message 2 Interrupt Pending (CANMSG2INT), offset 0x144**

The **CANMSG1INT** and **CANMSG2INT** registers hold the **INTPND** bits of the 32 message objects. By reading these bits, the CPU can check which message object has an interrupt pending. The **INTPND** bit of a specific message object can be changed through two sources: (1) the CPU via the **CANIFnMCTL** register, or (2) the message handler state machine after the reception or transmission of a frame.

This field is also encoded in the **CANINT** register.

The **CANMSG1INT** register contains the **INTPND** bits of the first 16 message objects in the message RAM; the **CANMSG2INT** register contains the **INTPND** bits of the second 16 message objects.

CAN Message n Interrupt Pending (CANMSGnINT)

CAN0 base: 0x4004.0000
 CAN1 base: 0x4004.1000
 Offset 0x140
 Type RO, reset 0x0000.0000

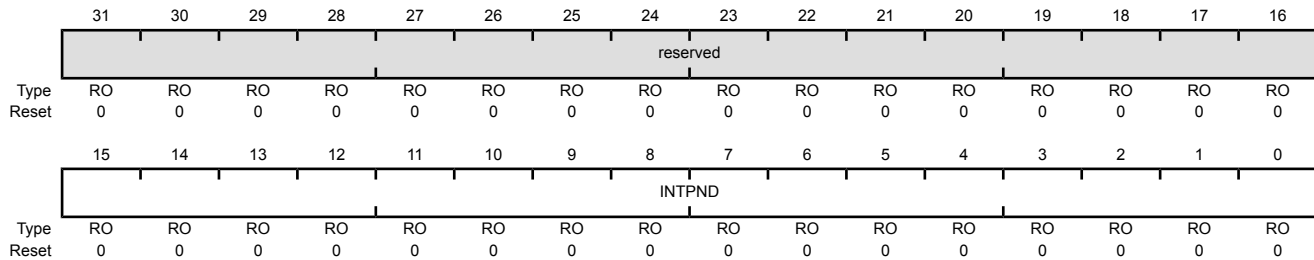

Bit/Field	Name	Type	Reset	Description
31:16	reserved	RO	0x0000	Software should not rely on the value of a reserved bit. To provide compatibility with future products, the value of a reserved bit should be preserved across a read-modify-write operation.
15:0	INTPND	RO	0x0000	Interrupt Pending Bits
	Value	Description		
	0	The corresponding message object is not the source of an interrupt.		
	1	The corresponding message object is the source of an interrupt.		

Register 36: CAN Message 1 Valid (CANMSG1VAL), offset 0x160

Register 37: CAN Message 2 Valid (CANMSG2VAL), offset 0x164

The **CANMSG1VAL** and **CANMSG2VAL** registers hold the **MSGVAL** bits of the 32 message objects. By reading these bits, the CPU can check which message object is valid. The message valid bit of a specific message object can be changed with the **CANIFnARB2** register.

The **CANMSG1VAL** register contains the **MSGVAL** bits of the first 16 message objects in the message RAM; the **CANMSG2VAL** register contains the **MSGVAL** bits of the second 16 message objects in the message RAM.

CAN Message n Valid (CANMSGnVAL)

CAN0 base: 0x4004.0000
 CAN1 base: 0x4004.1000
 Offset 0x160
 Type RO, reset 0x0000.0000



Bit/Field	Name	Type	Reset	Description
31:16	reserved	RO	0x0000	Software should not rely on the value of a reserved bit. To provide compatibility with future products, the value of a reserved bit should be preserved across a read-modify-write operation.
15:0	MSGVAL	RO	0x0000	Message Valid Bits
				Value Description
				0 The corresponding message object is not configured and is ignored by the message handler.
				1 The corresponding message object is configured and should be considered by the message handler.

23 Ethernet Controller

The Ethernet Controller has the following features:

- Conforms to the IEEE 802.3 specification
 - 10BASE-T/100BASE-TX IEEE-802.3 compliant
 - Supports 10/100 Mbps data transmission rates
 - Supports full-duplex and half-duplex (CSMA/CD) operation
 - Supports flow control and back pressure
 - Full-featured and enhanced auto-negotiation
 - Supports IEEE 802.1Q VLAN tag detection
- Conforms to IEEE 1588-2002 Timestamp Precision Time Protocol (PTP) protocol and the IEEE 1588-2008 Advanced Timestamp specification
 - Transmit and Receive frame time stamping
 - Precision Time Protocol
 - Flexible pulse per second output
 - Supports coarse and fine correction methods
- Multiple addressing modes
 - Four MAC address filters
 - Programmable 64-bit Hash Filter for multicast address filtering
 - Promiscuous mode support
- Processor offloading
 - Programmable insertion (TX) or deletion (RX) of preamble and start-of-frame data
 - Programmable generation (TX) or deletion (RX) of CRC and pad data
 - IP header and hardware checksum checking (IPv4, IPv6, TCP/UDP/ICMP)
- Highly configurable
 - LED activity selection
 - Supports network statistics with RMON/MIB counters
 - Supports Magic Packet and wakeup frames
- Efficient transfers using integrated Direct Memory Access (DMA)
 - Dual-buffer (ring) or linked-list (chained) descriptors

- Round-robin or fixed priority arbitration between TX/RX
- Descriptors support up to 8 kB transfer blocks size
- Programmable interrupts for flexible system implementation
- Physical media manipulation
 - MDI/MDI-X cross-over support
 - Register-programmable transmit amplitude
 - Automatic polarity correction and 10BASE-T signal reception

23.1 Block Diagram

Figure 23-1 on page 1532 shows the block diagram of the Ethernet MAC with an integrated PHY interface:

Figure 23-1. Ethernet MAC with Integrated PHY Interface

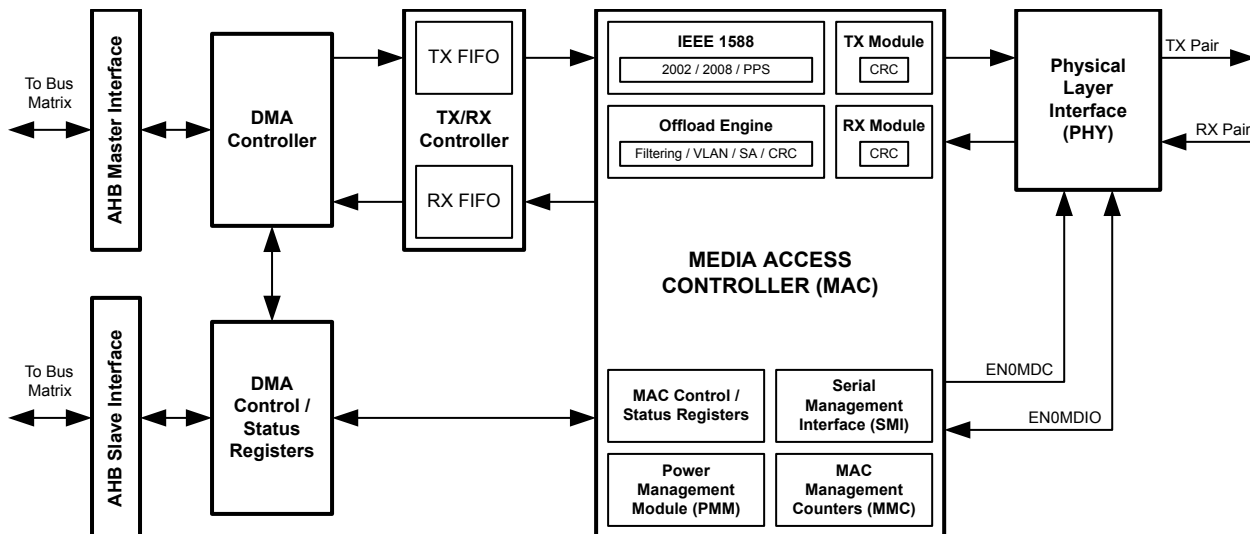

23.2 Signal Description

The following table lists the external signals of the Ethernet Controller and describes the function of each. Some of the Ethernet signals have dedicated functions while the others listed in the table are alternate functions for GPIO signals at reset. The column in the table below titled "Pin Mux/Pin Assignment" lists the possible GPIO pin placements for these Ethernet module signals. The `AFSEL` bit in the **GPIO Alternate Function Select (GPIOAFSEL)** register (page 778) should be set to assign the Ethernet signals. The number in parentheses is the encoding that must be programmed into the `PMCn` field in the **GPIO Port Control (GPIOCTL)** register (page 795) to assign the Ethernet signal to the specified GPIO port pin. For more information on configuring GPIOs, see "General-Purpose Input/Outputs (GPIOs)" on page 750. The remaining signals (with the word "fixed" in the Pin Mux/Pin Assignment column) have a fixed pin assignment and function.

Table 23-1. Ethernet Signals (128TQFP)

Pin Name	Pin Number	Pin Mux / Pin Assignment	Pin Type	Buffer Type	Description
EN0LED0	42 63	PF0 (5) PK4 (5)	O	TTL	Ethernet 0 LED 0.
EN0LED1	46 61	PF4 (5) PK6 (5)	O	TTL	Ethernet 0 LED 1.
EN0LED2	43 62	PF1 (5) PK5 (5)	O	TTL	Ethernet 0 LED 2.
EN0PPS	49 116	PG0 (5) PJ0 (5)	O	TTL	Ethernet 0 Pulse-Per-Second (PPS) Output.
EN0RXIN	53	fixed	I/O	TTL	Ethernet PHY negative receive differential input.
EN0RXIP	54	fixed	I/O	TTL	Ethernet PHY positive receive differential input.
EN0TXON	56	fixed	I/O	TTL	Ethernet PHY negative transmit differential output.
EN0TXOP	57	fixed	I/O	TTL	Ethernet PHY positive transmit differential output.
RBIAS	59	fixed	O	Analog	4.87-kΩ resistor (1% precision) for Ethernet PHY.

23.3 Functional Description

The Ethernet Controller is made up of the following sub-modules:

- Clock Control
- DMA Controller
- Transmit/Receive Controller (TX/RX Controller)
- Media Access Controller (MAC)
- AHB Bus Interface
- PHY Interface

The following sections describe the features and functions of each sub-module.

23.3.1 Ethernet Clock Control

23.3.1.1 PHY Interface

The Ethernet Controller Module and Integrated PHY receive two clock inputs:

- A gated system clock acts as the clock source to the Control and Status registers (CSR) of the Ethernet MAC. The SYSCLK frequency for Run, Sleep and Deep Sleep mode is programmed in the System Control module. Refer to “System Control” on page 227 for more information on programming SYSCLK and enabling the Ethernet MAC.
- The PHY receives the main oscillator (MOSC) which must be 25 MHz ± 50 ppm for proper operation. The MOSC source can be a single-ended source or a crystal. Figure 23-2 on page 1534 shows the clock inputs to the Ethernet Controller Module.

Figure 23-2. Ethernet MAC and PHY Clock Structure

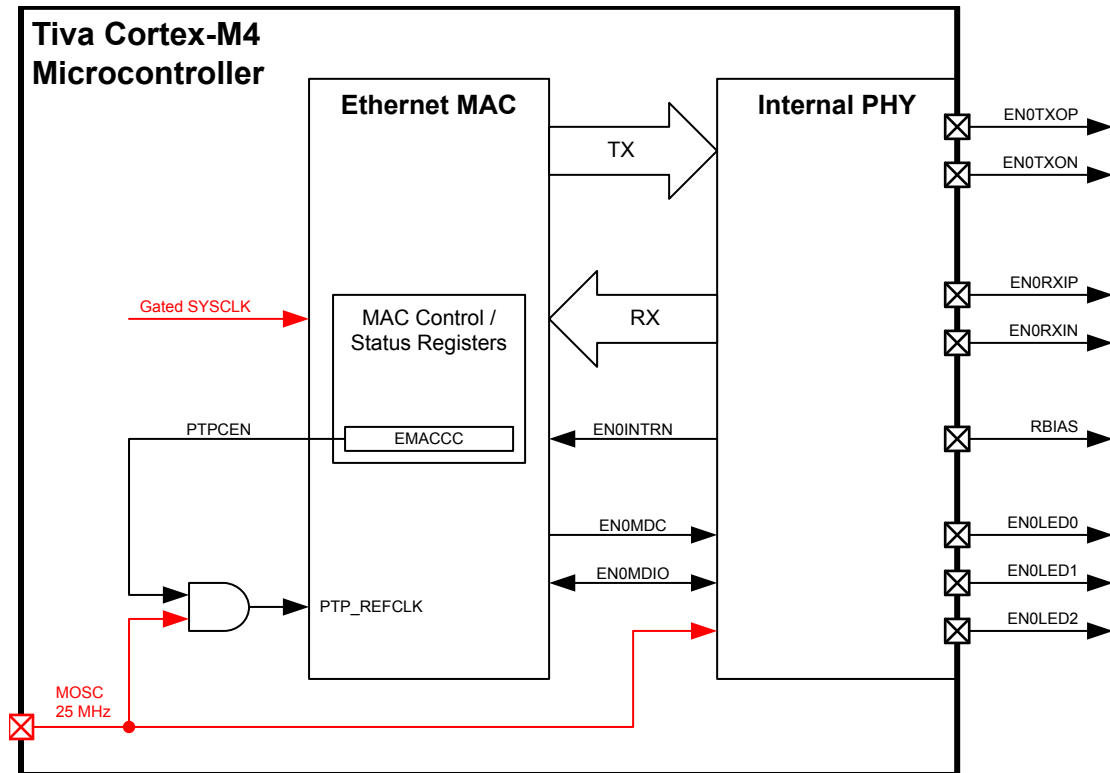

23.3.2 DMA Controller

The Ethernet Controller's integrated DMA is used to optimize data transfer between the MAC and system SRAM memory. The DMA has independent transmit and receive engines.

The DMA transmit engine transfers data from system memory to the Ethernet TX/RX Controller, while the receive engine transfers data from the RX FIFO to the system memory. The controller uses descriptors to efficiently move data from source to destination with minimal CPU intervention. The DMA is designed for packet-oriented data transfers such as frames in Ethernet. Fixed burst lengths of 1, 4, 8, or 16 words are supported along with re-initiation of bursts when retry or burst termination responses occur. For a burst retry, if the remaining address count is greater than 1 and the `RIB` bit in the **Ethernet MAC DMA Bus Mode (EMACDMABUSMOD)** register is clear, then the transfer resends data in one continuous burst. When one transfer is left, it is done as a single burst and the transaction is terminated immediately afterward. If the `RIB` bit in the **EMACDMABUSMOD** register is set, the DMA sends the remaining data in fixed burst sizes of 1, 4, 8, or 16 words.

The application may also choose between solely fixed bursts or mixed bursts by the DMA. If the `MB` bit is set and the `FB` bit is clear in the **EMACDMABUSMOD** register, then the DMA uses fixed bursts for burst sizes less than 16 and a full, non-divided burst for lengths greater than 16. Fixed burst lengths allow for more DMA bus arbitration with other masters. Maximum burst transfer lengths can be programmed for both the receive and transmit channels of the DMA through the `PBL`, `RPBL` and `8xPBL` bit fields in the **EMACDMABUSMOD** register.

The DMA Controller requests a read transfer only when it can accept the received burst data completely. Data read from the bus is always pushed into the DMA without any delay or busy cycles. The DMA requests write transfers only when it has sufficient data to transfer the burst completely. When operating in fixed burst length mode, the DMA interface continues to burst with dummy data

until the specified length is completed. The Ethernet controller can be programmed to interrupt the CPU in situations such as Frame Transmit and Receive transfer completion, and other normal/error conditions.

The integrated Ethernet DMA communicates through two data structures:

- Control and Status registers
- Descriptor lists and data buffers.

The DMA writes data frames received by the MAC to the receive buffer in system memory and transfers data frames for transmission from system memory to the MAC. Descriptors that reside in the system memory act as pointers to these buffers.

There are two descriptor lists: one for reception and one for transmission. The base address of each list is written into the **Ethernet MAC Receive Descriptor List Address (EMACRXDLADDR)** register at offset 0xC0C and the **Ethernet Mac Transmit Descriptor List Address (EMACTXDLADDR)** register at offset 0xC10, respectively.

The descriptor structure can contain up to 8 words (32 bytes). These are described in more detail in “Enhanced and Alternate Descriptors” on page 1537. A descriptor list is forward linked (either implicitly or explicitly). The last descriptor may point back to the first entry to create a ring structure. Explicit chaining of descriptors is accomplished by enabling second address chaining in both the Receive and Transmit descriptors (RDES0[14] and TDES0[20]). The descriptor lists reside in the SRAM memory address space. Each descriptor can point to a maximum of two buffers. This enables two buffers to be used at different physical addresses rather than contiguous buffers in memory.

The data buffer also resides in the physical memory space and consists of an entire frame or part of a frame, but cannot exceed a single frame. Buffers contain only data and buffer status is maintained in the descriptor. Data chaining refers to frames that span multiple data buffers. However, a single descriptor cannot span multiple frames. The DMA skips to the next frame buffer when the end-of-frame is detected. Data chaining can be enabled or disabled through the descriptors.

Note: The EMAC DMA Controller only has access to internal system SRAM memory.

23.3.2.1 Burst Access

The DMA attempts to execute fixed length Burst transfers if the **FB** bit is set in the **EMACDMABUSMOD** register. The maximum burst length is indicated and limited by the **PBL** field in the **EMACDMABUSMOD** register. The Receive and Transmit descriptors are always accessed in the maximum possible (limited by **PBL**) burst-size for the bytes to be read.

The TX DMA initiates a transfer only when there is sufficient space in the FIFO to accommodate the configured burst or remaining bytes of the end of a frame. When the DMA is configured for fixed-length burst, it transfers data using the best combination of fixed burst sizes of 4, 8, or 16 and single transactions. Otherwise when the **FB** bit is clear in the **EMACDMABUSMOD** register, the DMA transfers data as a continuous undefined burst and single transactions.

The RX DMA initiates a data transfer only when sufficient data to accommodate the configured burst is available in RX FIFO or when the end-of-frame (when it is less than the configured burst length) is detected in the RX FIFO. The DMA indicates the start address and the number of transfers required to the system. When the **FB** bit is set in the **EMACDMABUSMOD** register, then it transfers data using the best combination of fixed burst sizes of 4, 8, or 16 and single transactions. If the end-of-frame is reached before the fixed-burst ends, then dummy transfers are performed in order to complete the fixed-burst. Otherwise, if the **FB** bit is clear, the DMA transfers data using **INCR** (undefined length) and **SINGLE** transactions. When the DMA is configured for address-aligned transfers, both DMA engines ensure that the first burst transfer on the system bus is less than or

equal to the size of the configured `PBL` in the `EMACDMABUSMOD` register. Thus, all subsequent transfers start at an address that is aligned to the configured `PBL`. The DMA can only align the address for burst transfers up to size 16 because only bursts of 16 are supported.

23.3.2.2 Data Buffer Alignment

The transmit and receive data buffers do not have any restrictions on the start address alignment. For example, in systems with 32-bit memory, the start address for the buffers can be aligned to any of the four bytes. However, the DMA always initiates write transfers, with address aligned to the bus width and dummy data (old data) in the byte lanes that are not valid. This typically happens during the transfer of the beginning or end of an Ethernet frame. The software driver should discard the dummy bytes based on the start address of the buffer and size of the frame.

For example, if the transmit buffer address is `0x0000.0FF2`, and 15 bytes need to be transferred, then the DMA reads five full words from address `0x0000.0FF0`, but when transferring data to the TX FIFO, the extra bytes (the first two bytes) are dropped or ignored. Similarly, the last 3 bytes of the last transfer are also ignored. The DMA always ensures that it transfers a full 32-bit data to the TX FIFO, unless it is the end of frame.

If the receive buffer address is `0x0000.0FF2` and 15 bytes of a received frame need to be transferred, then the DMA writes five full words from address `0x0000.0FF0`. However, the first two bytes of first transfer and the last three bytes of the fifth transfer have dummy data. The DMA considers the offset address only if it is the first Receive buffer of the frame. The DMA ignores the offset address and performs full word writes for the middle and the last Receive buffer of the frame.

23.3.2.3 Buffer Size Calculations

The DMA does not update the size fields in the Transmit and Receive descriptors. The DMA updates only the status fields (`RDES` and `TDES`) of the descriptors. The driver has to perform the size calculations. The TX DMA transfers the exact number of bytes (indicated by buffer size fields of `TDES1`) to the MAC. If a descriptor is marked as first (`FS` bit of `TDES0` is set), then the DMA marks the first transfer from the buffer as the start-of-frame (`SOF`). If a descriptor is marked as last (`LS` bit of `TDES0`), then the DMA marks the last transfer from that data buffer as the end-of frame (`EOF`).

The RX DMA transfers data to a buffer until the buffer is full or the end-of frame is received from the RX/TX Controller. If a descriptor is not marked as last (`LS` bit of `RDES0`), then the descriptor's corresponding buffer(s) are full and the amount of valid data in a buffer is accurately indicated by its buffer size field minus the data buffer pointer offset when the `FS` bit of that descriptor is set. The offset is zero when the data buffer pointer is aligned to the data bus width. If a descriptor is marked as last, then the buffer may not be full (as indicated by the buffer size in `RDES1`). To compute the amount of valid data in this final buffer, the driver must read the frame length (`FL` bits of `RDES0`) and subtract the sum of the buffer sizes of the preceding buffers in this frame. The Receive DMA always transfers the start of next frame with a new descriptor.

Note: Even when the start address of a receive buffer is not aligned to the data width of 32-bit system bus, the system should allocate a receive buffer of a size aligned to the system bus width. For example, if the system allocates a 1,024-byte (1 KB) receive buffer starting from address `0x1000`, the software can program the buffer start address in the Receive descriptor to have a `0x1002` offset. The Receive DMA writes the frame to this buffer with dummy data in the first two locations (`0x1000` and `0x1001`). The actual frame is written from location `0x1002`. Thus, the actual useful space in this buffer is 1,022 bytes, even though the buffer size is programmed as 1,024 bytes, because of the start address offset.

23.3.2.4 DMA Arbiter

The arbiter inside the DMA module performs the arbitration between the Transmit and Receive channel accesses. The DMA can be configured to arbitrate in a round-robin or fixed-priority configuration. When the `DA` bit of the **EMACDMABUSMOD** register is clear, the DMA arbiter allocates the data bus in the ratio set by the `PR` bit field of the **EMACDMABUSMOD** register when both the TX and RX DMA request access at the same time. When the `DA` bit is set, the RX DMA always has priority over the TX DMA for data access by default. However if the `TXPR` bit of the **EMACDMABUSMOD** register is also set, then the TX DMA always gets priority over the RX DMA.

23.3.2.5 Enhanced and Alternate Descriptors

Enhanced Descriptors can contain up to eight words (32 bytes) and buffers of up to 8 KB (useful for Jumbo frames). Enhanced Descriptors support IEEE 1588-2008 Advanced Timestamp and IPC Full Checksum (Type 2) Offload. These enhanced features are enabled with the `TSEN` bit of the **EMACTIMSTCTRL** register and the `IPC` bit of the **EMACCFG** register, respectively.

When using Enhanced Descriptors, set the descriptor size to eight words with the Alternate Descriptor Size (`ATDS`) bit in the **Ethernet MAC DMA Bus Mode (EMACDMABUSMOD)** register. If these enhanced features are not enabled, the extended descriptors (DES4 to DES7) are not required. Therefore, the software can use Alternate Descriptors with a default size of 16 bytes (4 words). For alternate descriptors, the software should clear the Alternate Descriptor Size (`ATDS`) bit in the **Ethernet MAC DMA Bus Mode (EMACDMABUSMOD)** register.

See the section called “Enhanced Transmit Descriptor” on page 1537 and the section called “Enhanced Receive Descriptor” on page 1542 for more details on the descriptor structure.

Enhanced Transmit Descriptor

The MAC requires at least one descriptor for a transmit frame. In addition to two buffers, two byte-count buffers, and two address pointers, the transmit descriptor has control fields which can be used to control the MAC operation on per-transmit frame basis. Figure 23-3 on page 1538 shows the enhanced transmit descriptor. Software must program the control bits `TDES0[31:18]` during descriptor initialization. When the DMA updates the descriptor, it writes back all the control bits to their initialized value, clears the `OWN` bit and updates the status bits.

With advanced timestamp support, the snapshot of the timestamp to be taken can be enabled for a given frame by setting Bit 25 (`TTSE`) of `TDES0`. When the descriptor is closed (that is, when the `OWN` bit is cleared), the timestamp is written into `TDES6` and `TDES7`.

Note: When the Advanced Timestamp feature is enabled, software should set the `ATDS` bit of the **Ethernet MAC DMA Bus Mode (EMACDMABUSMOD)** register, offset `0xC00`, so that the DMA operates with extended descriptor size. When this control bit is reset to the default (0), the `TDES4-TDES7` descriptor space is not valid and only Alternate Descriptors are available, with a default size of 16 bytes (4 words).

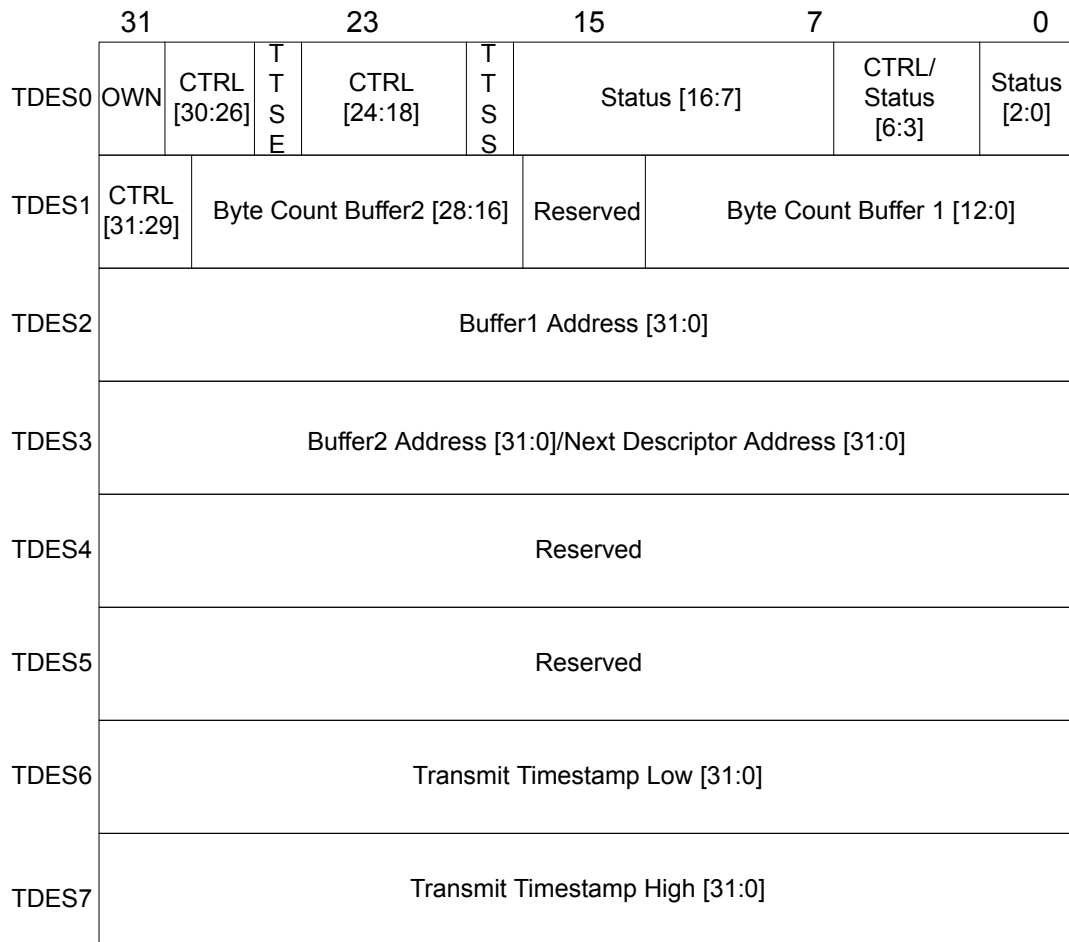
Figure 23-3. Enhanced Transmit Descriptor Structure

The following tables define the Enhanced Transmit Descriptors. Transmit Descriptor 0 (TDES0) contains the transmitted frame status and the descriptor ownership information. TDES1 contains the buffer sizes and other bits which control the descriptor chain or ring and the frame being transferred. TDES2 contains the address pointer to the first buffer of the descriptor. TDES3 contains the address pointer either to the second buffer of the descriptor or the next descriptor. TDES6 and TDES7 contain the timestamp.

Table 23-2. Enhanced Transmit Descriptor 0 (TDES0)

Bit	Description
31	OWN: Own Bit When set, this bit indicates that the descriptor is owned by the DMA. When this bit is reset, it indicates that the descriptor is owned by the Host. The DMA clears this bit either when it completes the frame transmission or when the buffers allocated in the descriptor are empty. The ownership bit of the First Descriptor of the frame should be set after all subsequent descriptors belonging to the same frame have been set. This avoids a possible race condition between fetching a descriptor and the driver setting an ownership bit.
30	IC: Interrupt on Completion When set this bit sets the Transmit Interrupt (TI) bit in the EMACDMARIS register when the frame contained in this descriptor has been transmitted.

Table 23-2. Enhanced Transmit Descriptor 0 (TDES0) (continued)

Bit	Description
29	<p>LS: Last Segment</p> <p>When set, this bit indicates that the buffer contains the last segment of the frame. When this bit is set, the TBS1 or TBS2 field in TDES1 should have a non-zero value.</p>
28	<p>FS: First Segment</p> <p>When set, this bit indicates that the buffer contains the first segment of a frame.</p>
27	<p>DC: Disable CRC</p> <p>When set, the MAC does not append a Cyclic Redundancy Check (CRC) to the end of the transmitted frame. This is valid only when the first segment (TDES0[28]) is set.</p>
26	<p>DP: Disable Padding</p> <p>When set, the MAC does not automatically add padding to a frame shorter than 64 bytes. When this bit is reset, the DMA automatically adds padding and CRC to a frame shorter than 64 bytes, and the CRC field is added despite the state of the DC (TDES0[27]) bit. This is valid only when the first segment (TDES0[28]) is set.</p>
25	<p>TTSE: Transmit Timestamp Enable</p> <p>When set, this bit enables IEEE1588 hardware timestamping for the transmit frame referenced by the descriptor. This bit is only valid when the First Segment Control bit (TDES0[28]) is set.</p>
24	<p>CRCR: CRC Replacement Control</p> <p>When set, the MAC replaces the last four bytes of the transmitted packet with recalculated CRC bytes. The CPU should ensure that the CRC bytes are present in the frame being transferred from the Transmit Buffer. CRC replacement is done only when Bit 27 (DC) is set to 1.</p>
23:22	<p>CIC: Checksum Insertion Control</p> <p>These bits control the insertion of checksums in Ethernet frames that encapsulate TCP, UDP, or ICMP over IPv4 or IPv6. This field is valid when the First Segment control bit (TDES0[28]) is set.</p> <ul style="list-style-type: none"> ■ 0x0 = Do nothing. Checksum Engine bypassed. ■ 0x1 = Insert IPv4 header checksum. Use this value to insert IPv4 header checksum when the frame encapsulates an IPv4 datagram. ■ 0x2 = Insert TCP/UDP/ICMP checksum. The checksum is calculated over the TCP, UDP, or ICMP segment only and the TCP, UDP, or ICMP pseudo-header checksum is assumed to be present in the corresponding input frame's Checksum field. An IPv4 header checksum is also inserted if the encapsulated datagram conforms to IPv4. ■ 0x3 = Insert a TCP/UDP/ICMP checksum that is fully calculated in this engine. The TCP, UDP, or ICMP pseudo-header is included in the checksum calculation, and the input frame's corresponding Checksum field has an all-zero value. An IPv4 Header checksum is also inserted if the encapsulated datagram conforms to IPv4. <p>The Checksum engine detects whether the TCP, UDP, or ICMP segment is encapsulated in IPv4 or IPv6 and processes its data accordingly.</p>
21	<p>TER: Transmit End of Ring</p> <p>When set, this bit indicates that the descriptor list reached its final descriptor. The DMA returns to the base address of the list, creating a descriptor ring.</p>
20	<p>TCH: Second Address Chained</p> <p>When set, this bit indicates that the second address in the descriptor is the Next Descriptor address rather than the second buffer address. When TDES0[20] is set, TBS2 (TDES1[28:16]) is a "don't care" value. TDES0[21] takes precedence over TDES0[20].</p>

Table 23-2. Enhanced Transmit Descriptor 0 (TDES0) (continued)

Bit	Description
19:18	<p>VLIC: VLAN Insertion Control</p> <p>When set, these bits request the MAC to perform VLAN tagging or untagging before transmitting the frames. If the frame is modified for VLAN tags, the MAC automatically recalculates and replaces the CRC bytes.</p> <p>The values of this field are as follows:</p> <ul style="list-style-type: none"> ■ 0x0= Do not add a VLAN tag ■ 0x1= Remove the VLAN tag from the frames before transmission. ■ 0x2= Insert a VLAN tag with the tag value programmed in the Ethernet MAC VLAN Tag Inclusion or Replacement (EMACVLNINCREP) register, offset 0x584. ■ 0x3= Replace the VLAN tag in frame with the tag value programmed in the EMACVLNINCREP register. This field is valid when the First Segment control bit (TDES0[28]) is set.
17	<p>TTSS:TX Timestamp</p> <p>This status bit indicates that a timestamp has been captured for the corresponding transmit frame. When this bit is set, TDES6 and TDES7 have timestamp values that were captured for the transmit frame. This field is valid only when the Last Segment control bit (TDES0[29]) in a descriptor is set.</p>
16	<p>IHE: IP Header Error</p> <p>When set, this bit indicates that the Checksum Offload engine detected an IP header error. This bit is valid only when TX Checksum Offload is enabled. Otherwise, it is reserved. If the Checksum Offload Engine detects an IP header error, it still inserts an IPv4 header checksum if the Ethernet Type field indicates an IPv4 payload.</p>
15	<p>ES: Error Summary</p> <p>Indicates the logical OR of the following bits:</p> <ul style="list-style-type: none"> ■ TDES0[16]: IP Header Error ■ TDES0[14]: Jabber Timeout ■ TDES0[13]: Frame Flush ■ TDES0[12]: Payload Checksum Error ■ TDES0[11]: Loss of Carrier ■ TDES0[10]: No Carrier ■ TDES0[9]: Late Collision ■ TDES0[8]: Excessive Collision ■ TDES0[2]: Excessive Deferral ■ TDES0[1]: Underflow error
14	<p>JT: Jabber Timeout</p> <p>When set, this bit indicates that the MAC transmitter has experienced a jabber timeout. This bit can only be set when the Jabber Disabled (JD) bit of the EMACCFG register is clear.</p>
13	<p>FF: Frame Flushed</p> <p>When set, this bit indicates that the DMA flushed the frame because of a software flush command given by the CPU.</p>
12	<p>IPE: IP Payload Error</p> <p>When set, this bit indicates that MAC transmitter detected an error in the TCP, UDP, or ICMP IP datagram payload. The transmitter checks the payload length received in the IPv4 or IPv6 header against the actual number of TCP, UDP, or ICMP packet bytes received from the application and issues an error status in case of a mismatch.</p>

Table 23-2. Enhanced Transmit Descriptor 0 (TDES0) (continued)

Bit	Description
11	<p>LC: Loss of Carrier</p> <p>When set, this bit indicates that Loss of Carrier occurred during frame transmission. This is valid only for the frames transmitted without collision and when the MAC operates in half-duplex mode.</p>
10	<p>NC: No Carrier</p> <p>When set, this bit indicates that the carrier sense signal from the PHY was not asserted during transmission.</p>
9	<p>LC: Late Collision</p> <p>When set, this bit indicates that frame transmission was aborted due to a collision occurring after the collision window (64 byte times including Preamble in MII Mode). Not valid if Underflow Error (bit 1) is set.</p>
8	<p>Excessive Collision</p> <p>When set, this bit indicates that the transmission was aborted after 16 successive collisions while attempting to transmit the current frame. If the Disable Retry (DR) bit in EMACCFG register is set, this bit is set after the first collision and the transmission of the frame is aborted.</p>
7	<p>VF: VLAN Frame</p> <p>When set, this bit indicates that the transmitted frame was a VLAN-type frame.</p>
6:3	<p>CC: Collision Count</p> <p>This 4-bit counter value indicates the number of collisions occurring before the frame was transmitted. The count is not valid when the Excessive Collision bit (TDES0[8]) is set.</p>
2	<p>ED: Excessive Deferral</p> <p>When set, this bit indicates that the transmission has ended because of excessive deferral of over 24,288 bit times (155,680 bits times when Jumbo Frame is enabled). This bit is dependent on the Deferral Check (DC) bit being enabled in the EMACCFG register.</p>
1	<p>UF: Underflow Error</p> <p>When set, this bit indicates that the MAC aborted the frame because the data arrived late from system memory. Underflow Error indicates that the DMA encountered an empty Transmit Buffer while transmitting the frame. The transmission process enters the suspended state and sets both Transmit Underflow (UNF) and Transmit Interrupt (TI) bit in the EMACDMARIS register.</p>
0	<p>DB: Deferred Bit</p> <p>This bit indicates the deferral mechanism is active and that the transmit state machine sends a JAM pattern to defer reception when it senses a carrier before a normal transmission is scheduled. This bit is only valid in half-duplex mode.</p>

Table 23-3. Enhanced Transmit Descriptor 1 (TDES1)

Bit	Description
31:29	<p>SAIC: SA Insertion Control</p> <p>These bits request the MAC to add or replace the Source Address field in the Ethernet frame with the value given in the MAC Address 0 register. If the Source Address field is modified in a frame, the MAC automatically recalculates and replaces the CRC bytes.</p> <p>The Bit 31 specifies the MAC Address Register (1 or 0) value that is used for Source Address insertion or replacement. The following list describes the values of Bits[30:29]:</p> <ul style="list-style-type: none"> ■ 0x0= Do not include the source address. ■ 0x1= Insert the source address. For reliable transmission, the application must provide frames without source addresses. ■ 0x2= Replace the source address. For reliable transmission, the application must provide frames with source addresses. ■ 0x3= Reserved <p>These bits are valid when the First Segment control bit (TDES0[28]) is set.</p>

Table 23-3. Enhanced Transmit Descriptor 1 (TDES1) (continued)

Bit	Description
28:16	TBS2: Transmit Buffer 2 Size This field indicates the second data buffer size in bytes. This field is not valid if TDES0[20] is set.
15:13	Reserved
12:0	TBS1: Transmit Buffer 1 Size These bits indicate the first data buffer byte size, in bytes. If this field is 0, the DMA ignores this buffer and uses Buffer 2 or the next descriptor, depending on the value of TCH (TDES0[20]).

Table 23-4. Enhanced Transmit Descriptor 2 (TDES2)

Bit	Description
31:0	Buffer 1 Address Pointer These bits indicate the physical address of Buffer 1. There is no limitation on the buffer address alignment. Note that the buffers are stored in SRAM.

Table 23-5. Enhanced Transmit Descriptor 3 (TDES3)

Bit	Description
31:0	Buffer 2 Address Pointer (Next Descriptor Address) Indicates the physical address of Buffer 2 when a descriptor ring structure is used. If the Second Address Chained (TDES0[20]) bit is set, this address contains the pointer to the physical memory where the Next Descriptor is present. The buffer address pointer must be aligned to the bus width only when TDES0[20] is set. Note that the buffers are stored in SRAM.

Table 23-6. Enhanced Transmit Descriptor 6 (TDES6)

Bit	Description
31:0	TTSL: Transmit Frame Timestamp Low This field is updated by DMA with the least significant 32 bits of the timestamp captured for the corresponding transmit frame. This field has the timestamp only if the Last Segment bit (LS), TDES0[29], in the descriptor is set and Timestamp status (TTSS) bit, TDES0[17], is set.

Table 23-7. Enhanced Transmit Descriptor 7 (TDES7)

Bit	Description
31:0	TTSH: Transmit Frame Timestamp High This field is updated by DMA with the most significant 32 bits of the timestamp captured for the corresponding receive frame. This field has the timestamp only if the Last Segment bit (LS), TDES0[29], in the descriptor is set and Timestamp status (TTSS) bit, TDES0[17], is set.

Enhanced Receive Descriptor

The DMA requires at least two descriptors when receiving a frame. The DMA always attempts to acquire an extra descriptor in anticipation of an incoming frame. Before the DMA closes a descriptor, it attempts to acquire the next descriptor even if no frames are received. In a single descriptor (receive) system, the subsystem generates a descriptor error if the receive buffer is unable to accommodate the incoming frame and the next descriptor is not owned by the DMA. Figure 23-4 on page 1543 shows the enhanced receive descriptor. This descriptor is used when Advanced Timestamp or the Checksum Offload Engine is enabled.

Note: When the Advanced Timestamp or Checksum Offload Engine features are enabled, software should set the ATDS bit of the **Ethernet MAC DMA Bus Mode (EMACDMABUSMOD)**

register, offset 0xC00, so that the DMA operates with extended descriptor size. When this control bit is reset to the default (0), the TDES4-TDES7 descriptor space is not valid and only Alternate Descriptors are available, with a default size of 16 bytes (4 words).

Figure 23-4. Enhanced Receive Descriptor Structure

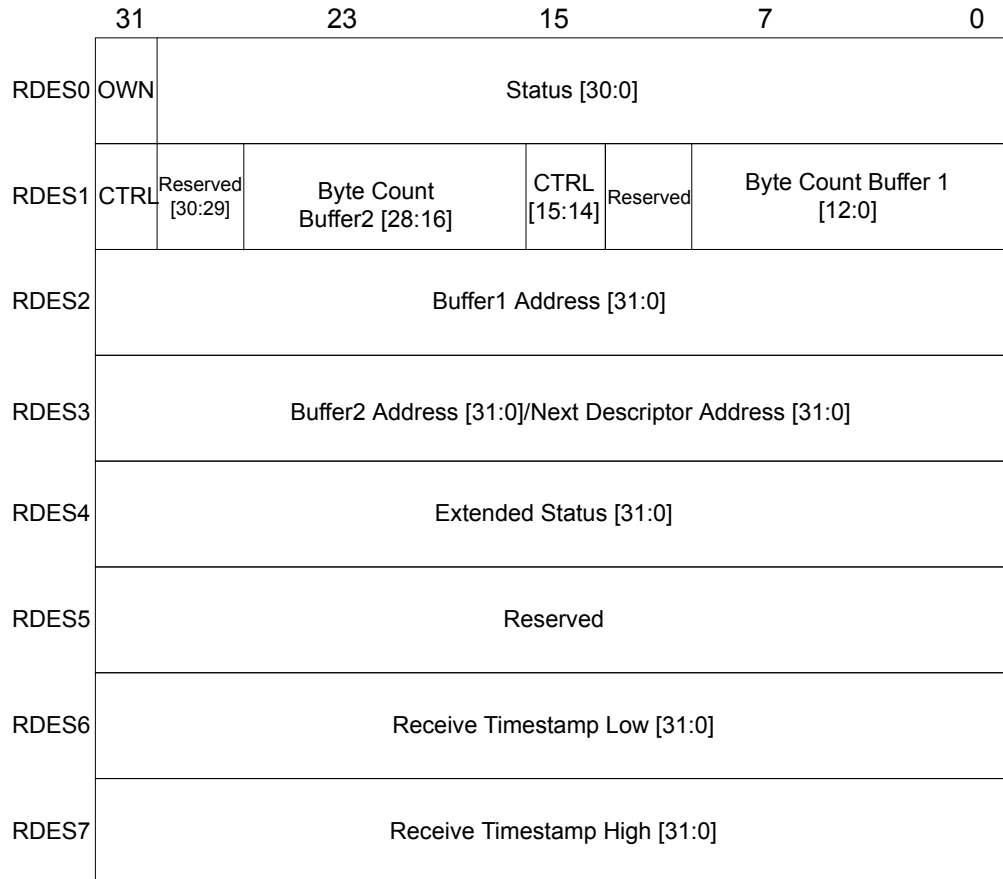

The following tables define the Enhanced Receive Descriptors. RDES0 contains the received frame status, the frame length, and the descriptor ownership information. RDES1 contains the buffer sizes and other bits that control the descriptor chain or ring. RDES2 and RDES3 contains the address pointers to the first and second data buffers in the descriptor. The availability of the extended status is indicated by Bit 0 of RDES0. RDES6 and RDES7 are available only when the Advanced Timestamp or IP Checksum Full Offload feature is enabled.

Table 23-8. Enhanced Receive Descriptor 0 (RDES0)

Bit	Description
31	OWN: Own Bit When set, this bit indicates that the descriptor is owned by the DMA. When this bit is reset, it indicates that the descriptor is owned by the Host. The DMA clears this bit either when it completes the frame reception or when the buffers that are associated with this descriptor are full.
30	AFM: Destination Address Filter Fail When set, this bit indicates a frame failed in the DA filter in the MAC.

Table 23-8. Enhanced Receive Descriptor 0 (RDES0) (continued)

Bit	Description
29:16	<p>FL: Frame Length</p> <p>These bits indicate the byte length of the received frame that was transferred to the system memory. This field is valid when the Last Descriptor (RDES0[8]) is set and either the Descriptor Error (RDES0[14]) or the Overflow Error bit (RDES0[11]) is clear.</p> <p>When the Last Descriptor bit is not set, this field indicates the accumulated number of bytes that have been transferred for the current frame. The inclusion of CRC length in the frame length depends on the settings of CRC configuration bits, <code>ACS</code> and <code>CST</code> in the EMACCFG register.</p>
15	<p>ES: Error Summary</p> <p>Indicates the logical OR of the following bits:</p> <ul style="list-style-type: none"> ■ RDES0[14]: Descriptor Error ■ RDES0[11]: Overflow Error ■ RDES0[7]: IPC Checksum (Type 2) or Giant Frame ■ RDES0[6]: Late Collision ■ RDES0[4]: Watchdog Timeout ■ RDES0[3]: Receive Error ■ RDES0[1]: CRC Error ■ RDES[4:3]: IP Header or Payload Error <p>This field is valid only when the Last Descriptor (RDES0[8]) is set.</p>
14	<p>DE: Descriptor Error</p> <p>When set, this bit indicates a frame truncation caused by a frame that does not fit within the current descriptor buffers, and that the DMA does not own the Next Descriptor. The frame is truncated. This field is valid only when the Last Descriptor (RDES0[8]) is set.</p>
13	<p>SAF: Source Address Filter Fail</p> <p>When set, this bit indicates that the SA field of frame failed the SA Filter in the MAC.</p>
12	<p>LE: Length Error</p> <p>When set, this bit indicates that the actual length of the frame received and the Length/Type field do not match. This bit is valid only when the Frame Type (RDES0[5]) bit is reset. Length error status is not valid when CRC error is present.</p>
11	<p>OE: Overflow Error</p> <p>When set, this bit indicates that the received frame is damaged because of buffer overflow in RX FIFO.</p> <p>Note: This bit is set only when the DMA transfers a partial frame to the application. This happens only when the RX FIFO is operating in the threshold mode. In the store-and-forward mode, all partial frames are dropped completely in RX FIFO.</p>
10	<p>VLAN: VLAN Tag</p> <p>When set, this bit indicates that the frame pointed to by this descriptor is a VLAN frame tagged by the MAC. The VLAN tagging depends on checking VLAN fields of the received frame configured in the Ethernet MAC VLAN Tag (EMACVLANTG) register, offset 0x01C</p>
9	<p>FS: First Descriptor</p> <p>When set, this bit indicates that this descriptor contains the first buffer of the frame. If the size of the first buffer is 0, the second buffer contains the beginning of the frame. If the size of the second buffer is also 0, the next Descriptor contains the beginning of the frame.</p>
8	<p>LS: Last Descriptor</p> <p>When set, this bit indicates that the buffers pointed to by this descriptor are the last buffers of the frame.</p>

Table 23-8. Enhanced Receive Descriptor 0 (RDES0) (continued)

Bit	Description
7	Timestamp Available or Giant Frame When Advanced Timestamp feature is enabled, this bit indicates that a snapshot of the Timestamp is written in descriptor words 6 (RDES6) and 7 (RDES7). This is valid only when the Last Descriptor bit (RDES0[8]) is set. Otherwise, this bit, when set, indicates the Giant Frame Status. Giant frames are larger than 1,518-byte (or 1,522-byte for VLAN or 2,000-byte when Bit 27 of MAC Configuration register is set) normal frames and larger than 9,018-byte (9,022-byte for VLAN) frame when Jumbo Frame processing is enabled.
6	LC: Late Collision When set, this bit indicates that a late collision has occurred while receiving the frame in half-duplex mode.
5	FT: Frame Type When set, this bit indicates that the Receive Frame is an Ethernet-type frame (the LT field is greater than or equal to 1,536). When this bit is reset, it indicates that the received frame is an IEEE 802.3 frame. This bit is not valid for Runt frames less than 14 bytes. In addition when the IPC bit is set in the EMACCFG register, this bit conveys different information. See Table 23-9 on page 1545.
4	RWT: Receive Watchdog Timeout When set, this bit indicates that the Receive Watchdog Timer has expired while receiving the current frame and the current frame is truncated after the Watchdog Timeout.
3	RE: Receive Error When set, this bit indicates that an error occurred during frame reception.
2	DE: Dribble Bit Error When set, this bit indicates that the received frame has a non-integer multiple of bytes (odd nibbles).
1	CE: CRC Error When set, this bit indicates that a Cyclic Redundancy Check (CRC) Error occurred on the received frame. This field is valid only when the Last Descriptor bit (RDES0[8]) is set.
0	Extended Status Available/RX MAC Address When set, this bit indicates that the extended status is available in descriptor word 4 (RDES4). This is valid only when the Last Descriptor bit (RDES0[8]) is set. This bit is invalid when Bit 30 is set.

Table 23-9 on page 1545 shows the frame information conveyed in bits 7, 5, and 0 of RDES0 when the Checksum Offload Engine is enabled and disabled through the `IPC` bit in the `EMACCFG` register.

Table 23-9. RDES0 Checksum Offload bits

Bit 5: Frame Type	Bit 7: IPC Checksum Error	Bit 0: Payload Checksum Error	IPC bit value in EMACCFG register	Frame Status
0	0	0	X	IEEE 802.3 Type frame (Length field value is less than 1,536). This status definition is valid even when the Checksum Offload engine is disabled.
1	0	0	0	IPv4/IPv6 Type frame in which no checksum error is detected.
1	0	0	1	The frame is an IEEE 802.3 Type frame (Length field value is greater than or equal to 1,536).
1	0	1	1	IPv4/IPv6 Type frame with a payload checksum error detected
1	1	1	1	IPv4/IPv6 Type frame with both IP header and payload checksum errors detected
0	0	1	1	IPv4/IPv6 Type frame with no IP header checksum error and the payload check bypassed, due to an unsupported payload
0	1	1	1	A Type frame that is neither IPv4 or IPv6 (the Checksum Offload engine bypasses checksum completely.)
0	1	0	X	Reserved

Table 23-10. Enhanced Receive Descriptor 1 (RDES1)

Bit	Description
31	Disable Interrupt on Completion When set, this bit prevents the setting of the Receive Interrupt (RI) bit in the EMACDMARIS register and prevents the receive interrupt from being asserted.
30:29	Reserved
28:16	RBS2: Receive Buffer 2 Size These bits indicate the second data buffer size. The buffer size must be a multiple of 4, even if the value of RDES3 (buffer 2 address pointer) is not aligned to the bus width. When the buffer size is not a multiple of 4, the resulting behavior is undefined. This field is not valid if RCH bit (RDES1[14]) is set.
15	RER: Receive End of Ring When set, this bit indicates that the descriptor list reached its final descriptor. The DMA returns to the base address of the list, creating a Descriptor Ring.
14	RCH: Second Address Chained When set, this bit indicates that the second address in the descriptor is the Next Descriptor address rather than the second buffer address. When this bit is set, RBS2 (RDES1[28:16]) is a "don't care" value. RDES1[15] takes precedence over RDES1[14].
13	Reserved
12:0	RBS1: Receive Buffer 1 Size These bits indicate the first data buffer size in bytes. The buffer size must be a multiple of 4 even if the value of RDES2 (buffer 1 address pointer) is not aligned to the bus width. When the buffer size is not a multiple of 4, the resulting behavior is undefined. If this field is 0, the DMA ignores this buffer and uses Buffer 2 or the next descriptor depending on the value of RCH (Bit 14).

Table 23-11. Enhanced Receive Descriptor 2 (RDES2)

Bit	Description
31:0	Buffer 1 Address Pointer These bits indicate the physical address of Buffer 1. The DMA uses the configured value for its address generation when the RDES2 value is used to store the start of frame. The DMA performs a write operation with the RDES2[1:0] bits as 0 during the transfer of the start of frame but the frame data is shifted as per the actual Buffer address pointer. The DMA ignores RDES2[1:0] if the address pointer is to a buffer where the middle or last part of the frame is stored. Note that buffers should be word-aligned.

Table 23-12. Enhanced Receive Descriptor 3 (RDES3)

Bit	Description
31:0	Buffer 2 Address Pointer (Next Descriptor Address) These bits indicate the physical address of Buffer 2 when a descriptor ring structure is used. If the Second Address Chained (RDES1[14]) bit is set, this address contains the pointer to the physical memory where the Next Descriptor is present. If RDES1[14] is set, the buffer (Next Descriptor) address pointer must be bus word-aligned (RDES3[1:0] = 0) However, when RDES1[14] is reset, there are no limitations on the RDES3 value, except for the following condition: The DMA uses the configured value for its buffer address generation when the RDES3 value is used to store the start of frame. The DMA ignores RDES3 [1:0] if the address pointer is to a buffer where the middle or last part of the frame is stored.

Table 23-13. Enhanced Received Descriptor 4 (RDES4)

Bit	Description
31:15	Reserved

Table 23-13. Enhanced Received Descriptor 4 (RDES4) (continued)

Bit	Description
14	<p>Timestamp Dropped</p> <p>When set, this bit indicates that the timestamp was captured for this frame but got dropped in the RX FIFO because of overflow.</p>
13	<p>PTP Version</p> <p>When set, this bit indicates that the received PTP message uses the IEEE 1588 version 2 format. When reset, it uses the version 1 format.</p>
12	<p>PTP Frame Type</p> <p>When set, this bit indicates that the PTP message is sent directly over Ethernet. When this bit is clear and the message type is non-zero, it indicates that the PTP message is sent over UDP-IPv4 or UDP-IPv6. The information about IPv4 or IPv6 can be obtained from Bits 6 and 7.</p>
11:8	<p>MessageType</p> <p>These bits are encoded to give the type of the message received:</p> <ul style="list-style-type: none"> ■ 0x0= No PTP message received ■ 0x1= SYNC (all clock types) ■ 0x2= Follow_Up (all clock types) ■ 0x3= Delay_Req (all clock types) ■ 0x4= Delay_Resp (all clock types) ■ 0x5= Pdelay_Req (in peer-to-peer transparent clock) ■ 0x6= Pdelay_Resp (in peer-to-peer transparent clock) ■ 0x7= Pdelay_Resp_Follow_Up (in peer-to-peer transparent clock) ■ 0x8= Announce ■ 0x9= Management ■ 0xA= Signaling ■ 0xB to 0xE= Reserved ■ 0xF= PTP packet with Reserved message type
7	<p>IPv6 Packet Received</p> <p>When set, this bit indicates that the received packet is an IPv6 packet. This bit is updated only when the <code>IPC</code> bit of the EMACCFG register is set.</p>
6	<p>IPv4 Packet Received</p> <p>When set, this bit indicates that the received packet is an IPv4 packet. This bit is updated only when the <code>IPC</code> bit of the EMACCFG register is set.</p>
5	<p>IP Checksum Bypassed</p> <p>When set, this bit indicates that the checksum offload engine is bypassed.</p>
4	<p>IP Payload Error</p> <p>When set, this bit indicates that the 16-bit IP payload checksum (that is, the TCP, UDP, or ICMP checksum) that the core calculated does not match the corresponding checksum field in the received segment. It is also set when the TCP, UDP, or ICMP segment length does not match the payload length value in the IP Header field. This bit is valid when either Bit 7 or Bit 6 is set.</p>
3	<p>IP Header Error</p> <p>When set, this bit indicates that either the 16-bit IPv4 header checksum calculated by the core does not match the received checksum bytes, or the IP datagram version is not consistent with the Ethernet Type value. This bit is valid when either Bit 7 or Bit 6 is set.</p>

Table 23-13. Enhanced Received Descriptor 4 (RDES4) (continued)

Bit	Description
2:0	<p>IP Payload Type</p> <p>These bits indicate the type of payload encapsulated in the IP datagram processed by the Receive Checksum Offload Engine (COE). The COE sets this field to 0x0 if it does not process the IP datagram's payload due to an IP header error or fragmented IP packet.</p> <ul style="list-style-type: none"> ■ 0x0= Unknown or did not process IP payload ■ 0x1= UDP ■ 0x2= TCP ■ 0x3= ICMP ■ 0x4 to 0x7= Reserved <p>This bit is valid when either Bit 7 or Bit 6 is set.</p>

Table 23-14. Enhanced Receive Descriptor 6 (RDES6)

Bit	Description
31:0	<p>RTSL: Receive Frame Timestamp Low</p> <p>This field is updated by the DMA with the least significant 32 bits of the timestamp captured for the corresponding receive frame. This field is updated by the DMA only for the last descriptor of the receive frame which is indicated by Last Descriptor status bit (RDES0[8]).</p>

Table 23-15. Enhanced Receive Descriptor 7 (RDES7)

Bit	Description
31:0	<p>RTSH: Receive Frame Timestamp High</p> <p>This field is updated by DMA with the most significant 32 bits of the timestamp captured for the corresponding receive frame. This field is updated by DMA only for the last descriptor of the receive frame which is indicated by Last Descriptor status bit (RDES0[8]).</p>

23.3.2.6 DMA Transmission Operation

The following sections describe the modes of the transmit operation.

TX DMA Default Operation

The TX DMA engine in default mode, operates as follows:

1. The CPU configures the transmit descriptor (TDES0-TDES3) and sets the OWN bit (TDES0[31]) after setting up the corresponding data buffers with the Ethernet frame.
2. When the **ST** bit of the **Ethernet MAC DMA Operation Mode (EMACDMAOPMODE)** register, offset 0xC18, is set, the DMA enters the RUN state.
3. While in RUN state, the DMA polls the Transmit Descriptor list for frames requiring transmission. After polling starts, it continues in either sequential descriptor ring order or chained order. If the DMA detects a descriptor flagged as owned by the CPU (TDES0[31]=0), or if an error condition occurs, transmission is suspended and both the Transmit Buffer Unavailable (**TU**) bit and the Normal Interrupt Summary (**NIS**) bit are set in the **Ethernet MAC DMA Interrupt Status (EMACDMARIS)** register, offset 0xC14. The transmit engine then proceeds to Step 9.

4. If the acquired descriptor is flagged as owned by the DMA (TDES0[31]=1), the DMA decodes the transmit data buffer address from the acquired descriptor.
5. If the acquired descriptor is flagged as owned by DMA (TDES0[31] = 1), the DMA decodes the Transmit Data Buffer address from the acquired descriptor.
6. The DMA fetches the transmit data from system memory and transfers the data to the TX/RX Controller for transmission.
7. If the Ethernet frame is stored over data buffers in multiple descriptors, the DMA closes the intermediate descriptor and fetches the next descriptor. Steps 3, 4, and 5 are repeated until the end of the Ethernet frame data is transferred to the TX/RX Controller.
8. When frame transmission is complete, if IEEE 1588 timestamping was enabled for the frame (as indicated in the transmit status) the timestamp value is written to the transmit descriptor (TDES6 and TDES7) that contains the end-of-frame buffer. The status information is then written to transmit descriptor TDES0. Because the OWN bit is cleared during this step, the CPU now owns this descriptor. If timestamping was not enabled for this frame, the DMA does not alter the contents of TDES6 and TDES7.
9. The Transmit Interrupt (TI) bit is set in the **EMACDMARIS** register after transmission completion of a frame that has Interrupt on Completion set in its last descriptor. The Interrupt on Completion bit resides in TDES0[30]. The DMA engine then returns to Step 3.
10. In the suspend state, the DMA tries to reacquire the descriptor (and thereby return to Step 3) when it receives a transmit poll demand in the **Ethernet MAC Transmit Poll Demand (EMACTXPOLLD)** register, offset 0xC04, and the Underflow Interrupt Status (UNF) bit is cleared in the **EMACDMARIS** register. If the CPU stopped the DMA by clearing the ST bit of the **EMACDMAOPMODE** register, the DMA enters the STOP state.

Figure 23-5 on page 1550 shows the flow for the TX DMA default operation.

Figure 23-5. TX DMA Default Operation Using Descriptors

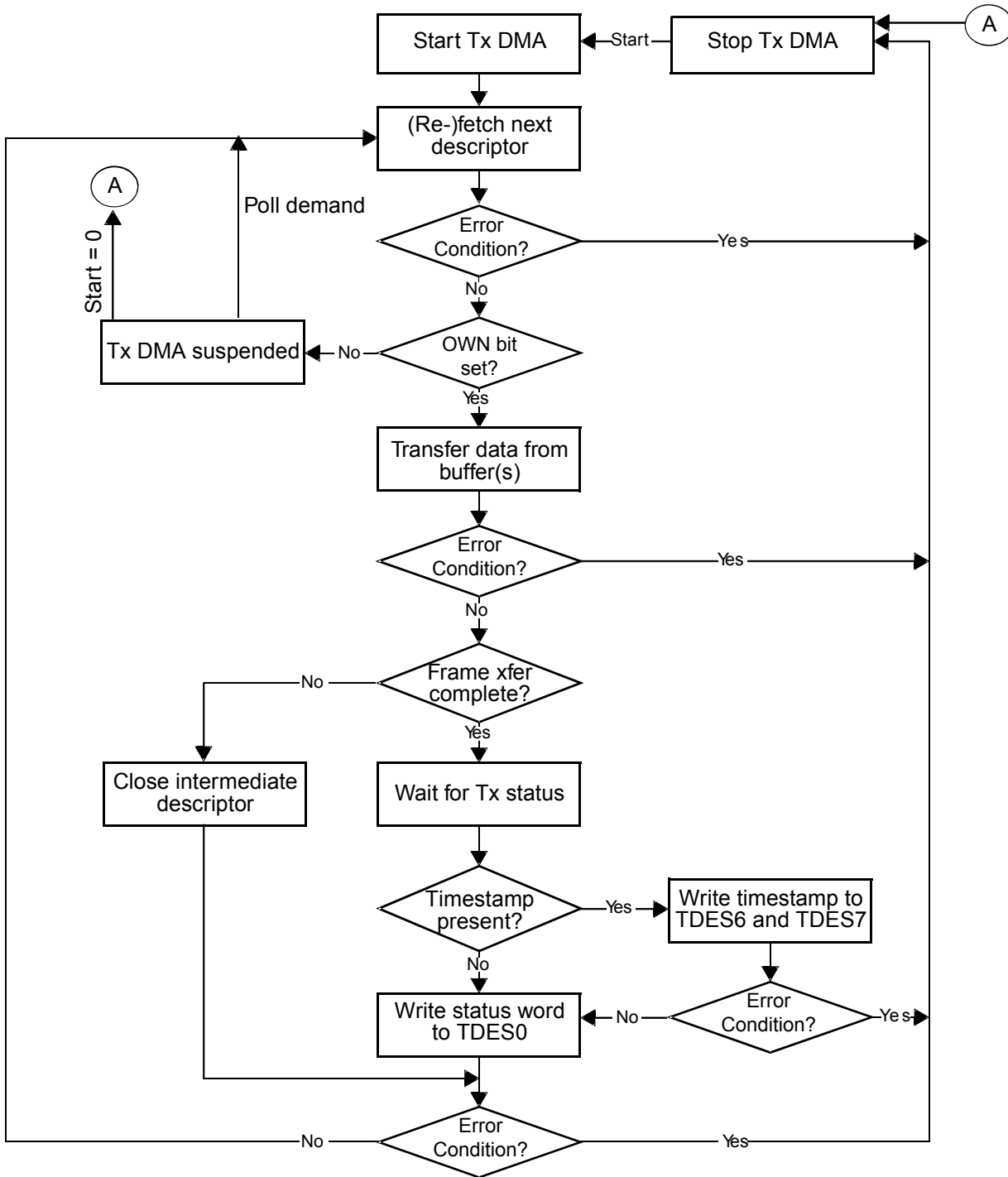

TX DMA OSF Mode Operation

While in the RUN state, the transmit process can simultaneously acquire two frames without closing the Status descriptor of the first if the OSF bit of the **EMACDMAOPMODE** register is set. As the transmit process finishes transferring the first frame, it immediately polls the transmit descriptor list

for the second frame. If the second frame is valid, the transmit process transfers this frame before writing the first frame's status information.

In Operate on Second Frame (OSF) mode, the RUN state TX DMA operates in the following sequence:

1. The DMA operates as described in Steps 1 to 6 (see page 1548).
2. Without closing the previous frame's last descriptor, the DMA fetches the next descriptor.
3. If the DMA owns the acquired descriptor, the DMA decodes the transmit buffer address in this descriptor. If the DMA does not own the descriptor, the DMA goes into SUSPEND mode and skips to 7.
4. The DMA fetches the Transmit frame from system memory and transfers the frame until the end-of-frame data is reached. It closes the intermediate descriptors if this frame is split across multiple descriptors.
5. The DMA waits for the previous frame's transmission status and timestamp. When the status is available, the DMA writes the timestamp to TDES6 and TDES7, if such timestamp was captured (as indicated by a status bit). The DMA then writes the status, with a cleared OWN bit, to the corresponding TDES0, thus closing the descriptor. If timestamping was not enabled for the previous frame, the DMA does not alter the contents of TDES6 and TDES7.
6. If enabled, the Transmit interrupt (TI) bit is set in the **EMACDMARIS** register, the DMA fetches the next descriptor and then proceeds to 3 (when Status is normal). If the previous transmission status shows an underflow error, the DMA goes into SUSPEND mode.
7. In SUSPEND mode, if a pending status and timestamp are received, the DMA writes the timestamp (if enabled for the current frame) to TDES6 and TDES7, then writes the status to the corresponding TDES0. It then sets relevant interrupts and returns to SUSPEND mode.
8. The DMA can exit SUSPEND mode and enter the RUN state only after receiving the Transmit Poll demand in the **EMACTXPOLL** register.

Note: The DMA fetches the next descriptor in advance before closing the current descriptor. Therefore, the descriptor chain should have more than two different descriptors for correct and proper operation.

Figure 23-6 on page 1552 shows the flow for the TX DMA Operate-On-Second-Frame (OSF) operation.

Figure 23-6. TX DMA OSF Mode Operation Using Descriptors

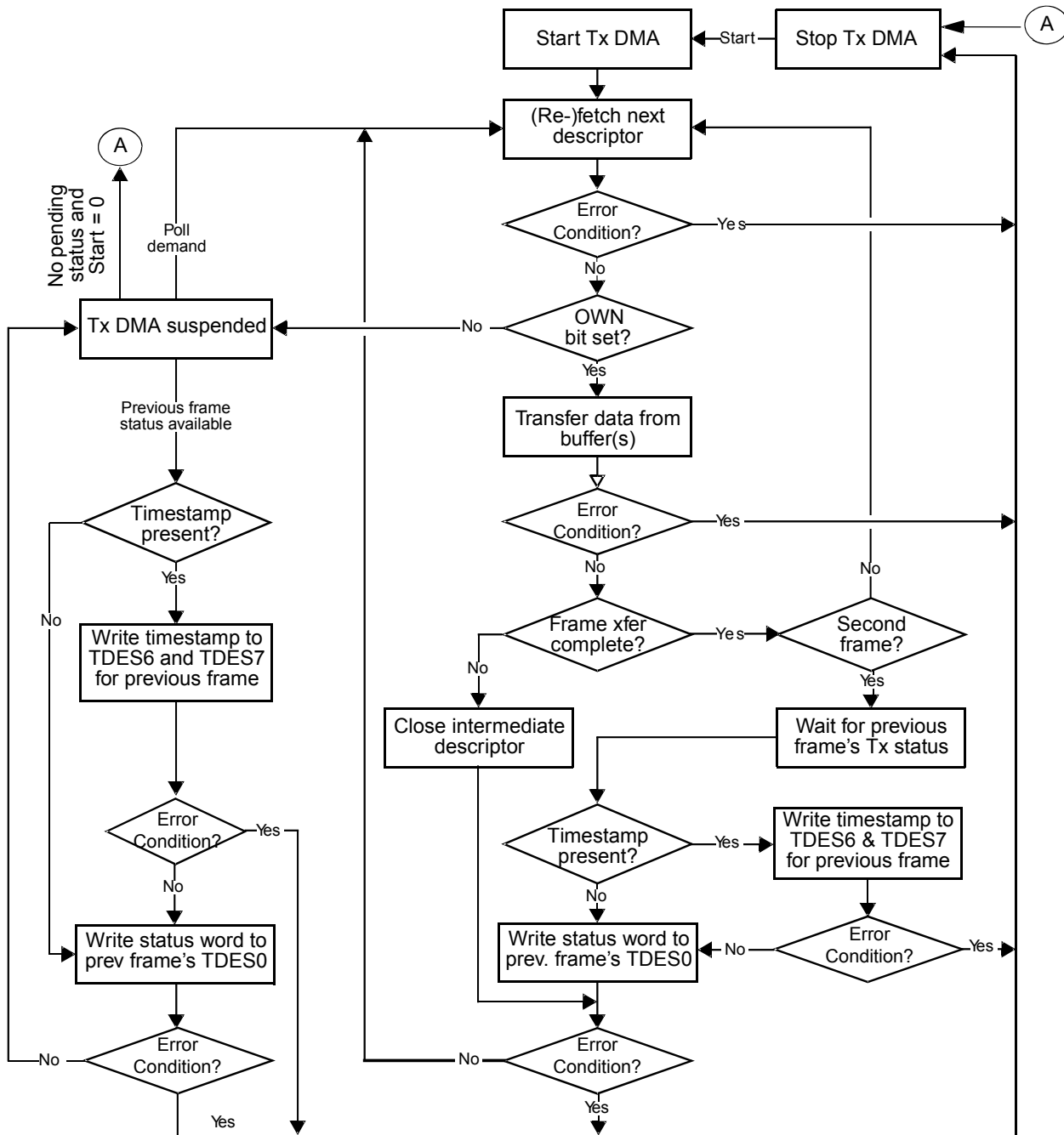

Transmit Frame Processing

The TX DMA expects that the data buffers contain complete Ethernet frames, excluding preamble, pad bytes, and Frame Check Sequence (FCS) fields. The Destination Address (DA), Source Address (SA), and Type/Length fields must contain valid data. If the Transmit Descriptor indicates that the MAC must disable CRC or PAD insertion, the buffer must have complete Ethernet frames (excluding preamble), including the CRC bytes. Frames can be data-chained and can span several buffers. Frames must be delimited by the First Segment Descriptor and the Last Segment Descriptor,

respectively. The First Descriptor bit is located at TDES0[28] and the Last Descriptor is located at TDES0[29].

As transmission starts, the First Descriptor must have TDES0[28] set. When this occurs, frame data transfers from the host memory buffer to the TX FIFO. Concurrently, if the current frame has the Last Segment Descriptor (TDES0[29]) clear, the transmit process attempts to acquire the next descriptor. The transmit process expects this descriptor to have TDES0[28] clear. If TDES0[29] is clear, it indicates an intermediary buffer. If TDES0[29] is set, it indicates the last buffer of the frame. After the last buffer of the frame has been transmitted, the DMA writes back the final status information to the Transmit Descriptor word of the descriptor that has the last segment bit set in Transmit Descriptor. At this time, if Interrupt on Completion (IC) bit is set, the TI bit in the **EMACDMARIS** register is set, the next descriptor is fetched and the process repeats.

The actual frame transmission begins after the TX FIFO has reached either the transmit threshold as configured by the TTC bit field of the **EMACDMAOPMODE** register, or a full frame is contained in the TX FIFO. To wait until there is a full frame in the TX FIFO the TSF bit in the **EMACDMAOPMODE** register must be set. Descriptors are released (OWN bit in the TDES0[31] cleared) when the DMA finishes transferring the frame.

Note: To ensure proper transmission of a frame and the next frame, the transmit descriptor that has the Last Descriptor bit (TDES0[29]) set, must specify a non-zero buffer size.

Transmit Polling Suspended

Transmit polling can be suspended by either of the following conditions:

- The DMA detects a descriptor owned by the CPU (TDES0[31]=0). To resume, the driver must give descriptor ownership to the DMA and then issue a Poll Demand command.
- A frame transmission is aborted when a transmit error because of underflow is detected. The appropriate Transmit Descriptor 0 (TDES0) bit is set.

If the DMA goes into SUSPEND state because of the first condition, then both the Normal Interrupt Summary (NIS) bit and the Transmit Buffer Unavailable (TU) bit are set in the **EMACDMARIS** register. If the second condition occurs, the Abnormal Interrupt Summary (AIS) bit and the Transmit Underflow (UNF) bit of the **EMACDMARIS** register are set and the information is written to Transmit Descriptor 0, causing the suspension.

In both cases, the position in the Transmit list is retained. The retained position is that of the descriptor following the last descriptor closed by the DMA. The driver must explicitly issue a Transmit Poll Demand command after rectifying the suspension case.

23.3.2.7 DMA Receive Operation

The following section describes the receive operation process.

Default Receive Operation

The RX DMA engine's reception sequence is as follows:

1. The host sets up receive descriptors (RDES0-RDES3) and sets the OWN bit (RDES0[31]).
2. When the SR bit of the **EMACDMAOPMODE** register is set, the DMA enters the RUN state. While in the RUN state, the DMA polls the Receive Descriptor list, attempting to acquire free descriptors. If the fetched descriptor is not free (is owned by the CPU), the DMA enters the Suspend state and jumps to Step 9.

3. The DMA decodes the receive data buffer address from the acquired descriptors.
4. Incoming frames are processed and placed in the acquired descriptor's data buffers.
5. When the buffer is full or the frame transfer is complete, the RX DMA engine fetches the next descriptor.
6. If the current frame transfer is complete, the DMA proceeds to Step 7. If the DMA does not own the next fetched descriptor and the frame transfer is not complete (EOF is not yet transferred), the DMA sets the Descriptor Error (DE) bit in RDES0 (unless flushing is disabled through the `DFE` bit in the **EMACDMAOPMODE** register). The DMA closes the current descriptor (clears the OWN bit) and marks it as intermediate by clearing the Last Segment (LS) bit in the RDES0 value. If flushing is not disabled, then the DMA would mark it as the last descriptor. In either case, the DMA proceeds to Step 8. If the DMA does own the next descriptor but the current frame transfer is not complete, the DMA closes the current descriptor as intermediate and reverts to Step 4.
7. If IEEE 1588 timestamping is enabled, the DMA writes the timestamp to the current descriptor's RDES6 and RDES7. It then takes the receive frame's status and writes the status word to the current descriptor's RDES0, with the OWN bit cleared and the Last Segment (LS) bit set. If the host stopped the RX DMA by clearing the `SR` bit of the **EMACDMAOPMODE** register, DMA goes to the STOP state, otherwise the RX DMA proceeds to Step 8.
8. The RX DMA engine checks the last descriptor's OWN bit. If the CPU owns the descriptor (OWN bit is 0), the `RU` bit of the **EMACDMARIS** register is set and the DMA RX engine enters the SUSPEND state. If the DMA owns the descriptor, the engine returns to Step 4 and awaits the next frame.
9. Before the RX DMA engine enters the SUSPEND state, partial frames are flushed from the RX FIFO. Flushing can be controlled through the `DFE` bit of the **EMACDMAOPMODE** register.
10. The RX DMA enters the STOP state if the CPU has cleared the `SR` bit of the **EMACDMAOPMODE** register. Otherwise, it exits the SUSPEND state when a Receive Poll Demand is given or the start of the next frame is available from the RX FIFO. The DMA engine proceeds to Step 2 and re-fetches the next descriptor.

The DMA does not acknowledge accepting status from the TX/RX Controller until it has completed the timestamp write-back and is ready to perform status write-back to the descriptor.

If software has enabled timestamping through the **Ethernet MAC Timestamp Control (EMACTIMSTCTRL)** register, offset 0x700, when a valid timestamp is not available for the frame (for example, because the receive FIFO was full before the timestamp could be written to it), the DMA writes all-ones to RDES6 and RDES7. Otherwise if timestamping is not enabled, RDES6 and RDES7 remain unchanged.

Figure 23-7 on page 1555 shows the flow of a RX DMA Operation.

Figure 23-7. RX DMA Operation Flow

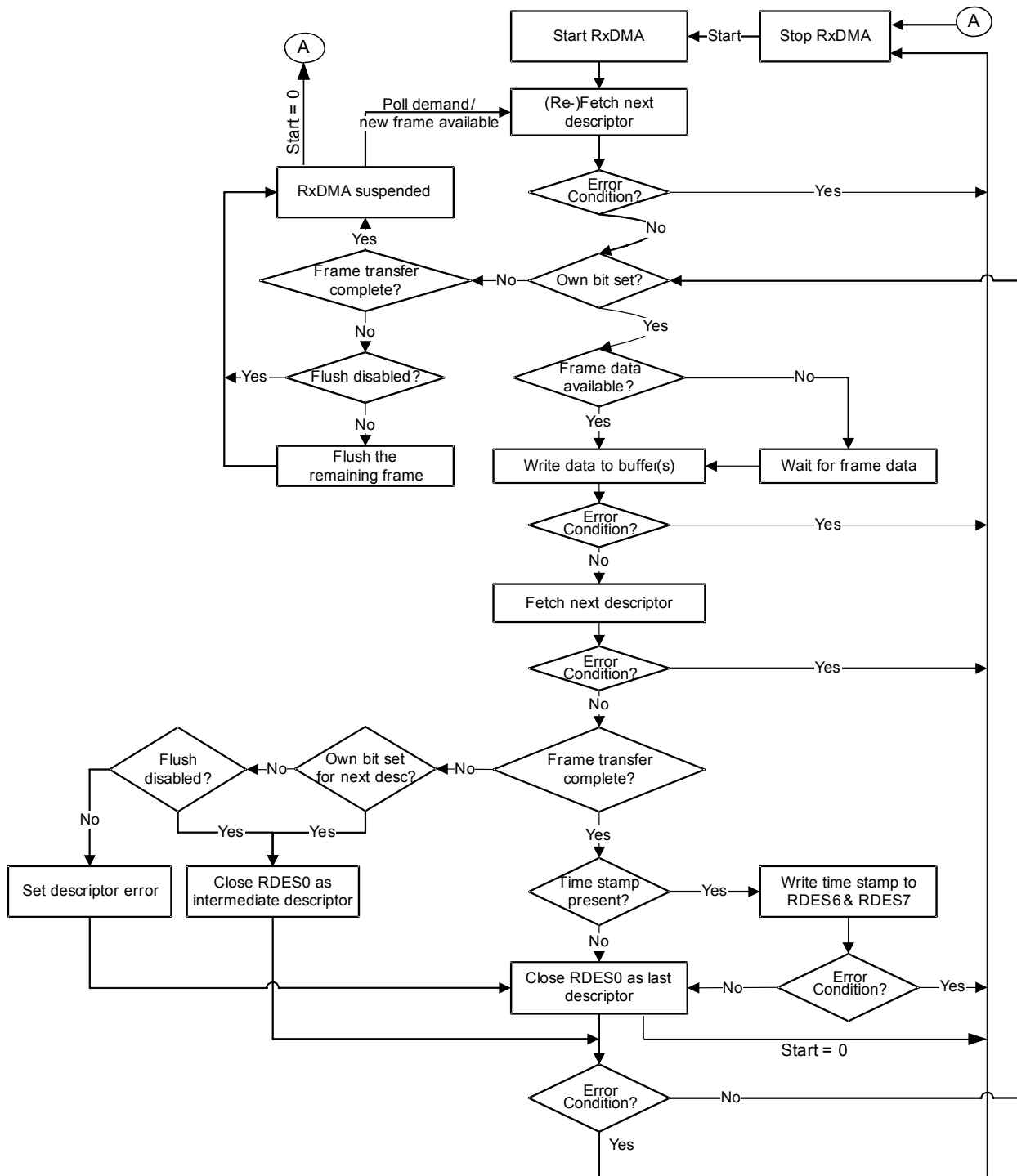

Receive Descriptor Acquisition

The Receive Engine always attempts to acquire an extra descriptor in anticipation of an incoming frame. Descriptor acquisition is attempted if any of the following conditions is satisfied:

- The `SR` bit of the **EMACDMAOPMODE** register has been set immediately after being placed in the RUN state.
- The data buffer or current descriptor is full before the frame ends for the current transfer.
- The controller has completed frame reception, but the current receive descriptor is not yet closed.
- The receive process has been suspended because of a host-owned buffer (`RDES0[31]=0`) and a new frame is received.
- A receive poll demand has been issued.

Receive Frame Processing

The MAC transfers the received frames to the system memory only when the frame passes the address filter and the frame size is greater than or equal to configurable threshold bytes set for the RX FIFO, or when the complete frame is written to the RX FIFO in store-and-forward mode.

If the frame fails the address filtering, it is dropped in the MAC block unless the Receive All (`RA`) bit is set in the **Ethernet MAC Frame Filter (EMACFRAMEFLTR)**, offset 0x004. If the `RA` bit is set, then the MAC passes all received frames. Frames that are shorter than 64 bytes, because of collision or premature termination, can be removed from the RX FIFO if the `DEF` bit is clear in the **EMACDMAOPMODE** register.

After 64 bytes have been received, the TX/RX Controller requests the DMA block to begin transferring the frame data to the receive buffer pointed by the current descriptor. The DMA sets the First Descriptor (`RDES0[9]`) bit to delimit the frame after the DMA Interface becomes ready to receive a data transfer (if DMA is not fetching transmit data from the system memory). The descriptors are released when the `OWN` (`RDES0[31]`) bit is reset to 0, either as the data buffer fills up or as the last segment of the frame is transferred to the receive buffer. If the frame is contained in a single descriptor, both Last Descriptor (`RDES0[8]`) and First Descriptor (`RDES0[9]`) are set.

The DMA fetches the next descriptor, sets the Last Descriptor (`RDES0[8]`) bit, and releases the `RDES0` status bits in the previous frame descriptor. Then the DMA sets the `RI` bit of the **EMACDMARIS** register. The same process repeats unless the DMA encounters a descriptor flagged as being owned by the host. If this occurs, the receive process sets the `RU` bit of the **EMACDMARIS** and enters the SUSPEND state. The position in the receive list is retained.

Receive Process Suspend

If a new receive frame arrives while the receive process is in SUSPEND state, the DMA refetches the current descriptor in the system memory. If the descriptor is now owned by the DMA, the receive process re-enters the RUN state and starts frame reception. If the descriptor is still owned by the CPU, by default, the DMA discards the current frame at the top of the RX FIFO and increments the missed frame counter. If more than one frame is stored in the RX FIFO, the process repeats. The discarding or flushing of the frame at the top of the RX FIFO can be prevented by disabling flushing through the `DEF` bit of the **EMACDMAOPMODE** register. In such conditions, the receive process sets the Receive Buffer Unavailable (`RU`) status and returns to the SUSPEND state.

23.3.2.8 DMA Interrupts

Interrupts can be generated as a result of various transfer events. The current status of interrupts can be read from the **EMACDMARIS** register and are enabled to trigger an interrupt through the programming of the **Ethernet MAC DMA Interrupt Mask (EMACDMAIM)** register. There are two groups of transfer event interrupts: Normal and Abnormal. The following lists the two groups:

- Normal Interrupts:
 - Transmit Interrupt (TI, bit 0): Indicates that frame transmission is complete.
 - Transmit Buffer Unavailable (TU, bit 2): Indicates the CPU owns the next descriptor in the transmit list and the DMA cannot acquire it.
 - Receive Interrupt (RI, bit 6): Indicates the frame reception is complete.
 - Early Receive Interrupt (ERI, bit 14): Indicates the DMA has filled the first half of the data buffer of the packet
- Abnormal Interrupts:
 - Transmit Process Stopped (TPS, bit 1): Indicates transmission is stopped.,
 - Transmit Jabber Timeout (TJT, bit 3): Indicates the Transmit Jabber Timer expired.
 - Receive FIFO Overflow (OVF, bit 4): Indicates the receive buffer had an overflow during frame reception.
 - Transmit Underflow (UNF, bit 5): Indicates the transmit buffer had an underflow during frame transmission.
 - Receive Buffer Unavailable (RU, bit): Indicates the CPU owns the next descriptor in the receive list and the DMA cannot acquire it.
 - Receive Process Stopped (RPS, bit 8): Indicates the receive process entered the STOP state.
 - Receive Watchdog Timeout (RWT, bit 9): Indicates a frame length greater than 2 KB is received (10,240 when Jumbo Frame is enabled)
 - Early Transmit Interrupt (ETI, bit 10): Indicates a frame to be transmitted is fully transferred to the TX FIFO.
 - Fatal Bus Error (FBI, bit 13): Indicates a bus error occurred.

Any of the interrupts in the Normal Interrupt group that are enabled in the **EMACDMAIM** register are ORed together to create the Normal Interrupt Summary (NIS) bit in the **EMACDMARIS** register. Any of the interrupts in the Abnormal Interrupt group that are enabled in the **EMACDMAIM** register are ORed together to create the Abnormal Interrupt Summary (AIS) bit in the **EMACDMARIS** register. Interrupts are cleared by writing a 1 to the corresponding bit position in the **EMACDMARIS** register. When all enabled interrupts within a group are cleared, the corresponding summary bit is cleared.

Interrupts are not queued and if the interrupt event occurs again before the driver has responded to it, no additional interrupts are generated. An interrupt is only generated once for simultaneous, multiple events. The driver must read the **EMACDMARIS** register for the cause of the interrupt.

The **Ethernet MAC Receive Interrupt Watchdog Timer (EMACRXINTWDT)** register, offset 0xC24 can be used to control the Receive Interrupt (RI) assertion. If the RDES1[31] bit (Receive Interrupt) bit has not been set in the receive descriptor and the **EMACRXINTWDT** register is programmed with a non-zero value, it gets activated as soon as the RX DMA completes a transfer of a received frame to system memory without asserting the receive interrupt. When this counter runs out as per the programmed value, the RI bit is set in the **EMACDMARIS** register and the interrupt is asserted

if the corresponding `RI` bit is enabled in the **EMACDMAIM** register. This counter gets disabled before it runs out if a frame is transferred to memory and the `RI` bit is set because it is enabled for that descriptor.

23.3.2.9 DMA Bus Error

If an internal bus error occurs during a DMA transfer, the fatal bus error (`FBI`) interrupt is set in the **EMACDMARIS** register and the Access Error status (`AE`) bit field in the **EMACDMARIS** register indicates the type of error that caused the bus error. The DMA controller can resume operation only after soft resetting the Ethernet MAC and the re-initializing the DMA.

23.3.3 TX/RX Controller

The TX/RX Controller consists of a FIFO memory which buffers and regulates the frames between the system memory and the MAC. It also controls the data transferred between clock domains. Both the transmit and receive data paths are 32-bits wide. The TX FIFO and RX FIFO are each 2 KB in depth.

At reset, the TX/RX Controller is configured and ready to manage data flow to and from the DMA to the MAC. Note that the DMA and MAC must be initialized by the application out of reset.

23.3.3.1 Transmit (TX) Control Path

The DMA controller is used for all Ethernet transmissions. The Ethernet frames are read from memory and transferred to the TX FIFO by the DMA. When the MAC is available, the frame is transferred from the FIFO. When the end-of-frame (EOF) is transferred, the MAC notifies the DMA the status of the transmission.

The TX FIFO has a depth of 2 KB. The FIFO fill level has the capability of triggering the DMA to initiate a burst transfer. The DMA also transfers start-of-frame (SOF), end-of-frame (EOF), CRC and pad-insertion information to the TX/RX Controller so that this information can be passed to the MAC when it is ready for transmission from the TX FIFO.

Data can be transmitted to the MAC in threshold mode or store-and-forward mode. If the `TTC` field is configured in the **Ethernet MAC DMA Operation Mode (EMACDMAOPMODE)** register at offset `0xC18` and the `TSF` bit in the same register is `0x0`, then the TX Controller is operating in threshold mode. In this mode, the data is transferred to the MAC when the number of bytes in the FIFO crossed the value configured in the `TTC` bit field or when the end-of-frame is written before the threshold is crossed. In store-and forward mode, the `TTC` bit field is configured and the `TSF` bit is set. Data is transferred to the MAC only when one or more of the following conditions are true:

- A complete frame is stored in the FIFO
- The TX FIFO becomes almost full
- The TX FIFO does not have space to accommodate the requested burst length

With these conditions, the TX Controller continues store-and-forward mode even if the Ethernet frame length is bigger than the TX FIFO size.

The TX FIFO can be flushed of all contents by setting the `FTF` bit in the **EMACDMAOPMODE** register. This bit is self-clearing and initializes the FIFO pointers to the default state. If the `FTF` bit is set during a frame transfer from the TX Controller to the MAC, then the TX Controller stops further transfer. Early termination of the transfer causes a underflow event and this status is communicated to the DMA.

Transmit Operation

During a transmit, single-packet or double-packets can reside in the buffer. The following describes the details of each:

- **Single-packet transmit:** During single packet transmission, the DMA controller fetches data from the CPU memory and forwards it to the TX FIFO and continues to receive data until the end-of-frame is transferred. The data is transmitted from the TX FIFO to the MAC by the TX/RX Controller when the threshold level is crossed or a full packet of data is received into the TX FIFO. When the TX/RX Controller receives acknowledgment from the MAC that it has received the EOF, it notifies the DMA so another transmit can begin.
- **Two-packet transmit:** Because the DMA must update the descriptor status before releasing it to the CPU, there can be at most two frames inside a transmit FIFO. The second frame is fetched by the DMA and put into the TX FIFO only if the `OSF` bit is set in the **EMACDMAOPMODE** register at offset `0xC18`. If this bit is not set, the next frame is fetched from memory only after the MAC has completely processed the frame and the DMA has released the descriptors.

If the `OSF` bit is set, the DMA starts fetching the second frame immediately after completing the transfer of the first frame to the FIFO. It does not wait for the status to be updated. The TX/RX Controller receives the second frame into the FIFO while transmitting the first frame. As soon as the first frame has been transferred and the status is received from the MAC, the TX/RX Controller sends the acknowledgement to the DMA. If the DMA has already completed sending the second packet to the TX/RX Controller, it must wait for the status of the first packet before proceeding to the next frame.

Collision and Retransmission

If a collision occurs at the MAC application interface while the TX/RX Controller is transferring data to the MAC, the transmission is aborted and the MAC indicates a retry attempt by giving a collision status before the EOF is transferred to the TX/RX Controller from the DMA. This enables the TX/RX Controller to retry transmission of the frame data from the FIFO.

After more than 96 bytes are transferred to the MAC, the FIFO controller clears space in the FIFO and makes it available to the DMA to transfer more data. Retransmission is not possible after this threshold is crossed or when the MAC indicates a late collision event.

When a frame transmission is aborted because of underflow and a collision event follows, which initiates a retry, then the retry has higher priority than the abort.

TX FIFO Flush Operation

The TX FIFO can be flushed by setting the `FTF` bit in the **EMACDMAOPMODE** register. The flush operation is immediate and the TX/RX Controller clears the TX FIFO and the corresponding pointers to the initial state even if it is in the middle of transferring a frame to the MAC. The data which is already accepted by the MAC transmitter is not flushed. This data is scheduled for transmission and results in an underflow event because the TX FIFO did not complete the transfer or the rest of the frame. As in all underflow conditions, a runt frame is transmitted and observed on the line. The status of such a frame is marked with both underflow and frame flush events in the Transmit Descriptor 0 (TDES0) word.

The TX/RX Controller also stops accepting any data from the DMA during the flush operation. It generates and transfers Transmit Status Words to the application for the frames that are flushed inside the FIFO, including partial frames. Frames that are completely flushed in the TX/RX Controller are identified by setting the Flush Status (FF) bit in the Transmit Descriptor 0 (TDES0) word. The TX/RX Controller completes the flush operation when the DMA accepts all of the status words for

the frames that were flushed and then clears the TX FIFO Flush control (FTF) bit in the **EMACDMAOPMODE** register. At this point, the TX/RX Controller starts accepting new frames from the DMA.

Transmit Status Word

At the end of the transfer of the Ethernet frame to the MAC and after the MAC completes the transmission of the frame, the TX/RX delivers a transmit status word (TDES0) to the application. If IEEE timestamping is enabled, the TX/RX Controller returns the specific frame's 64-bit timestamp, along with the transmit status word. The fields for the Transmit Descriptors are described in "Enhanced and Alternate Descriptors" on page 1537.

23.3.3.2 Receive (RX) Control Path

TX/RX Controller receives frames from the MAC and pushes them into the RX FIFO. When the fill level of the RX FIFO crosses the programmed RX Threshold, the DMA is notified.

Receive Operation

During a receive operation the TX/RX Controller is a slave to the MAC. The steps of the receive operation are as follows:

1. The MAC receives a frame. This data, along with SOF, EOF and byte enable information is sent to the TX/RX Controller. The TX/RX Controller accepts the data and pushes it into the RX FIFO. After the EOF is transferred, the MAC drives the status word, which is also pushed in to the RX FIFO.
2. When timestamp is enabled by setting the **TSEN** bit in the **Ethernet MAC Timestamp Control (EMACTIMSTCTRL)** register, at offset 0x700, and the 64-bit timestamp is present with the receive status, it is appended to the frame and received by the MAC and pushed into the TX FIFO before the corresponding receive status word is written. Thus, two additional locations per frame are taken for storing timestamp in the RX FIFO.
3. Data can be sent to the TX/RX Controller in cut-through mode or store-and-forward mode. When the **RTC** bit field of the **EMACDMAOPMODE** register is set to 0x0 and cut-through mode is enabled (**RSF=0**), the TX/RX Controller indicates availability to transfer to the DMA when 64 bytes are in the RX FIFO or a full packet of data has been received into the RX FIFO. When the DMA initiates transfers to system memory, the TX/RX Controller continues to transfer data from the RX FIFO until a complete packet has been transferred. When EOF has occurred, the TX/RX Controller sends the status word to the DMA.

Note: The timestamp transfer takes two clock cycles and the lower 32-bits of the timestamp are sent first when timestamping is enabled.

When the **RSF** bit is set in the **EMACDMAOPMODE** register, RX FIFO store-and-forward mode is enabled and a frame is read by the DMA only after it is completely written into the RX FIFO. In this mode, only valid frames are read and forwarded to the application. In cut-through mode, some error frames are not dropped because the error status is received at the end of the frame and by that time the start of that frame has already been read out of the RX FIFO.

The TX/RX Controller is capable of storing any number of frames in the RX FIFO as long as it is not full.

Error Handling

If the RX FIFO is full before it receives the EOF data from the MAC, an overflow is declared, the entire frame (including the status word) is dropped and the **Ethernet MAC Missed Frame and Buffer Overflow Counter (EMACMFBOC)** register is incremented. These error actions occur even if the `FEF` bit is set in the **EMACDMAOPMODE** register. If the start address of such a frame has already been transferred to the TX/RX Controller, the rest of the frame is dropped and a dummy EOF is written to the FIFO along with its status word. The descriptor status indicates a partial frame because of overflow. In such frames, the Frame Length (FL) field in the receive descriptor is invalid. If the RX FIFO is configured to operate in the store-and-forward mode and if the length of the received frame is more than the FIFO size, overflow occurs and all such frames are dropped. During error handling, the DMA flushes the error frame currently being read.

The Receive control logic can filter error and undersized frames if enabled through configuring the `FEF` or `FUF` bit of the **EMACDMAOPMODE** register. Filtering must be set before the start address of the frame has been transferred to the TX/RX controller for it to take effect.

Receive Word Status

At the end of an Ethernet frame transfer to the system memory, the TX/RX Controller sends a receive status word, `RDES0`, to the application. Until the end of the frame transfer, the TX/RX Controller stores the status and frame length in an asynchronous status FIFO whose depth is determined by the size of the RX FIFO (2K) and the minimum size of the frame. If the frame size is 64, then the asynchronous FIFO depth is $2048/64 = 32$ bytes in length. Note that when the status of a partial frame (because of overflow) is sent to the application, the Frame Length field of `RDES0` is not valid and is set to zero.

Note: When the timestamp feature is enabled, the receive status field is greater than 32-bits. An extended status bit-field [63:32] provides information about the received Ethernet payload when it is carrying PTP packets or TCP/UDP/ICMP over IP packets. Since the data bus is 32 bits, the status is transferred over two clock cycles.

23.3.3.3 MAC Flow Control

Flow control mechanisms can be enabled for both the TX and RX FIFO datapath, depending on the configurations in the **Ethernet MAC Flow Control (EMACFLOWCTL)** register at offset 0x018 and the `DUPM` bit configuration in the **Ethernet MAC Configuration (EMACCFG)** register at offset 0x000.

Table 23-16. TX MAC Flow Control

TFE bit in EMACFLOWCTL	DUPM bit in EMACCFG	Description
0	X	The MAC transmitter does not perform the flow control or backpressure operation.
1	0	The MAC transmitter performs backpressure when the <code>FCBBPA</code> bit in the Ethernet MAC Flow Control (EMACFLOWCTL) register is set.
1	1	The MAC transmitter sends a pause frame when the <code>FCBBPA</code> bit in the Ethernet MAC Flow Control (EMACFLOWCTL) register is set.

Table 23-17. RX MAC Flow Control

TFE bit in EMACFLOWCTL	DUPM bit in EMACCFG	Description
0	X	The MAC receiver does not detect the received Pause frames.
1	0	The MAC receiver does not detect the received Pause frames but recognizes such frames as Control frames.

Table 23-17. RX MAC Flow Control (continued)

TFE bit in EMACFLOWCTL	DUPM bit in EMACCFG	Description
1	1	The MAC receiver detects or processes the Pause frames and responds to such frames by stopping the MAC transmitter.

23.3.4 MAC Operation

The MAC module enables the CPU to transmit and receive data over Ethernet in compliance with the IEEE 802.3-2008 standard. The MAC supports the interface to the PHY and is comprised of a receive and transmit module whose features are described in the following sections.

23.3.4.1 MAC Transmit Module

MAC transmission is initiated when the TX/RX Controller transmits data with the start of frame (SOF) signal asserted. When the SOF signal is detected, the MAC accepts the data and begins transmitting to the PHY. The time required to transmit the frame data after the application initiates transmission varies, depending on delay factors like inter-frame gap (IFG) delay, time to transmit preamble or start of frame data (SFD), and any back-off delays for half-duplex mode. Until then, the MAC does not accept data received from the TX/RX Controller.

After the end-of-frame (EOF) is transferred to the MAC, the MAC completes the normal transmission and gives the status of transmission to the TX/RX Controller. If a normal collision (in half-duplex mode) occurs during transmission, the MAC conveys the transmit status to the TX/RX Controller. It then accepts and drops all further data until the next SOF is received. The TX/RX Controller should retransmit the same frame from SOF on observing a retry request (in the transmit status word) from the MAC. The MAC issues an underflow status if the TX/RX Controller is not able to provide the data continuously during the transmission. During the normal transfer of a frame from the TX/RX Controller, if the MAC receives an SOF without getting an EOF for the previous frame, it ignores the SOF and considers the new frame as a continuation of the previous frame.

If the number of bytes received from memory is less than 60 bytes, zeros are automatically appended to the transmitting frame to make the data length exactly 46 bytes to meet the minimum data field requirement of IEEE802.3.

The transmit engine controls the operation of Ethernet frame transmission. Some of the functions of the transmit module include:

- Output of (32-bit) Transmit Status (TDES0) to the application at the end of normal transmission or collision
- Generating preamble and Start of Frame Data (SFD)
- Generating jam pattern in half-duplex mode
- Supporting Jabber time-out
- Supporting flow control
- Generating timestamp information for transmission
- Scheduling frame transmission to satisfy inter-frame gap (IFG) and back-off delays
- Generating CRC and FCS field for Ethernet Frame
- Generating pause frames as necessary in full duplex mode

When a new frame transmission is requested, the MAC transmit module sends out a preamble and SFD, followed by the data in the TX FIFO. The preamble is defined as 7 bytes of 0xAA and the SFD is defined as 1 byte of 0xAB pattern.

The collision window is defined as 1 slot time (512-bit times). If a collision occurs any time from the beginning of the frame to the end of the CRC field, the MAC transmit module sends a 32-bit jam pattern of 0x5555.5555 to inform all other stations that a collision has occurred. If the collision is seen during the preamble transmission phase, the MAC transmit module completes the transmission of the preamble and SFD, and then sends the jam pattern. If the collision occurs after the collision window and before the end of the FCS field, the MAC transmit module sends a 32-bit jam pattern and sets the late collision bit in the transmit frame status. The jam pattern generation is applicable only to half-duplex mode.

A jabber timer is enabled by default at reset in the MAC module. If the JD bit in the **EMACCFG** register at offset 0x000 is clear and the MAC module has transferred more than 2K bytes, the jabber timer causes the MAC module to stop transmission of Ethernet frames. The timeout is changed to 10 KB when the Jumbo Frame Enable (JFEN) bit is enabled in the **EMACCFG** register.

The MAC transmit module uses a deferral mechanism for flow control (back pressure) in half-duplex mode. When the application requests to stop receiving frames, the transmit module sends a jam pattern of 32 bytes whenever it senses the reception of a frame, provided the transmit flow control is enabled. This results in a collision and the remote station backs off. If the application requests a frame to be transmitted, the frame is scheduled and transmitted even when backpressure is activated. If the backpressure is activated for a long time (more than 16 consecutive collision events occur) then the remote stations abort their transmissions because of excessive collisions.

If IEEE 1588 timestamping is enabled for the transmit frame, the MAC transmit module takes a snapshot of the system time when the start-of-frame data is output on the bus.

23.3.4.2 MAC Transmit Module CRC Generator

The Transmit CRC Generator is used to generate the 32-bit CRC for the FCS field of the Ethernet frame. The encoding is defined by the following generating polynomial:

$$G(x) = x^{32} + x^{26} + x^{23} + x^{22} + x^{16} + x^{12} + x^{11} + x^{10} + x^8 + x^7 + x^5 + x^4 + x^2 + x^1.$$

The calculated CRC is valid on the next clock after the data is received.

23.3.4.3 MAC Receive Module

A receive operation is initiated when the MAC detects start-of-frame data (SFD). The MAC strips the preamble and SFD before proceeding to process the frame. The header fields are checked for the filtering and the FCS field is used to verify the CRC for the frame. The received frame is stored in a buffer until the address filtering is performed. The frame is dropped in the MAC if it fails the address filter.

Some of the functions of the MAC receive module are as follows:

- Stripping the preamble, SFD and carrier extension of the Ethernet frame
- Providing IEEE 1588 timestamping whenever an SFD is detected
- Converting receive nibble data into bytes in MII mode
- Decoding Length/Type field of the Ethernet frame
- Auto-CRC/pad stripping if enabled in the **EMACCFG** register

- Frame data and status buffering for received frames
- Data path conversion of 8-bit data to 32-bit data
- Frame filtering
- Attaching calculated IP checksum input to frame
- Detecting receiving pause frames and pausing the frame transmission for the delay specified withing the received pause frame
- Receive IP Checksum Verification
- Performing destination and source address checking functions on all received frames and reporting the address filtering status to the receive frame controller module.

23.3.4.4 MAC Receive Module CRC Generator

The receive CRC Generator is used to generate the 32-bit CRC for the FCS field of the Ethernet frame. The encoding is defined by the following generating polynomial:

$$G(x) = x^{32} + x^{26} + x^{23} + x^{22} + x^{16} + x^{12} + x^{11} + x^{10} + x^8 + x^7 + x^5 + x^4 + x^2 + x + 1$$

The calculated CRC is valid on the next clock after the data is received.

23.3.4.5 MAC Receive Frame Controller

If the `RA` bit is set in the **Ethernet MAC Frame Filter (EMACFRAMEFLTR)** register, offset 0x004, the MAC Receive Frame Controller initiates the data transfer to the RX FIFO as soon as four bytes of Ethernet data are received. At the end of the data transfer, the received frame status that includes the frame filter bits (SA or DA filter fail) and status are also sent. These bits indicate to the application whether the received frame has passed the filter controls. This module does not drop any frame on its own in this mode.

If the `RA` bit is clear, the MAC Receive Frame Controller performs frame filtering based on the destination/source address (the application still needs to perform another level of filtering if it decides not to receive any bad frames like runt, CRC error frames, etc.) After receiving the destination or source address bytes, the MAC Receive Frame Controller checks the filter-fail sign for an address match. On detecting a filter-fail, the frame is dropped and not transferred to the application.

Note: When the PMT module is configured for power-down mode, all received frames are dropped and not forwarded to the application.

23.3.5 IEEE 1588 and Advanced Timestamp Function

The MAC module supports the IEEE 1588-2002 Timestamp Precision Time Protocol (PTP) and the IEEE 1588-2008 Advanced Timestamp features. PTP enables precise synchronization of clocks in measurement and control systems implemented with technologies such as network communication, local computing, and distributed objects. The PTP applies to systems communicating by a local area network supporting multicast messaging. This protocol enables heterogeneous systems that include clocks of varying inherent precision, resolution, and stability to synchronize. The protocol supports system-wide synchronization accuracy in the sub-microsecond range with minimal network and local clock computing resources.

The PTP is transported over UDP/IP. The system or network is classified into master and slave nodes for distributing the timing and clock information. Figure 23-8 on page 1565 shows the process that PTP uses for synchronizing a slave node to a master node by exchanging PTP messages.

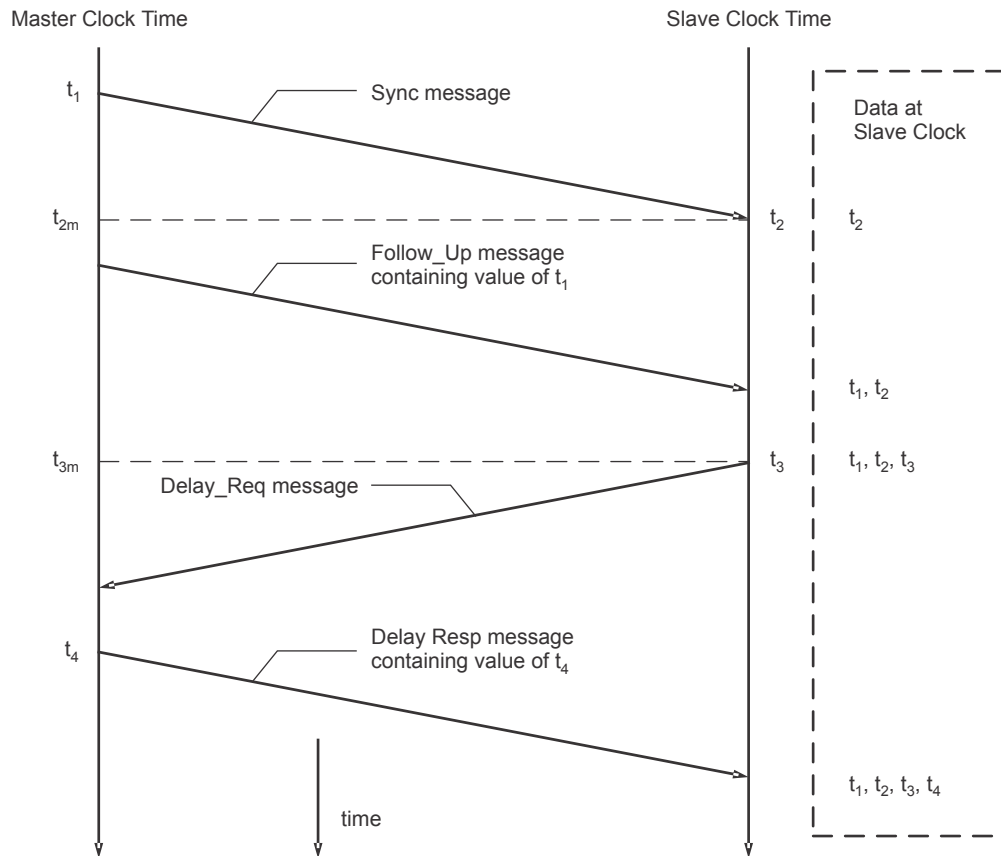
Figure 23-8. Networked Time Synchronization

As shown in Figure 23-8 on page 1565, the PTP uses the following process:

1. The master broadcasts the PTP Sync messages to all its nodes. The Sync message contains the master's reference time information. The time at which this message leaves the master's system is t_1 . This time is captured at the MII interface.
2. The slave receives the Sync message and also captures the exact time, t_2 , using its timing reference.
3. The master sends a Follow_Up message to the slave, which contains t_1 information for later use.
4. The slave sends a Delay_Req message to the master, noting the exact time, t_3 , at which this frame leaves the MAC.
5. The master receives the message, capturing the exact time, t_4 , at which it enters its system.
6. The master sends the t_4 information to the slave in the Delay_Resp message.
7. The slave uses the four values of t_1 , t_2 , t_3 , and t_4 to synchronize its local timing reference to the master's timing reference.

Most of the PTP implementation is done in the software above the UDP layer. However, the hardware support is required to capture the exact time when specific PTP packets enter or leave the Ethernet

MAC. This timing information is captured and returned to the software for the proper implementation of PTP with high accuracy.

23.3.5.1 System Time Module

The System Time module maintains a 64-bit time and is updated using the MOSC clock source as the PTP clock reference. This time is the source for taking snapshots (timestamps) of the Ethernet frames being transmitted or received. Two methods of updating the system time counter are implemented. The counter can be initialized or corrected using the coarse correction method. In this method, the initial value or the offset value is written to the **MAC System Time - Seconds Update (EMACTIMSECU)** register along with the **MAC System Time - Nanoseconds Update (EMACTIMNANOU)** register. For initialization the system time counter is written with the value in these registers, while for system time correction, the offset value is added to or subtracted from the system time.

In the fine correction method, the slave clock's frequency drift with respect to the master clock is corrected over a period of time instead of in one clock, as in coarse correction. This helps maintain linear time and does not introduce drastic changes (or a large jitter) in the reference time between PTP Sync message intervals. In this method, an accumulator sums up the contents of the **EMACTIMADD** register, as shown in Figure 23-9 on page 1567. The arithmetic carry that the accumulator generates is used as a pulse to increment the system time counter. The accumulator and the addend are 32-bit registers. Here, the accumulator acts as a high precision frequency multiplier or divider.

Figure 23-9. System Time Update Using Fine Correction Method

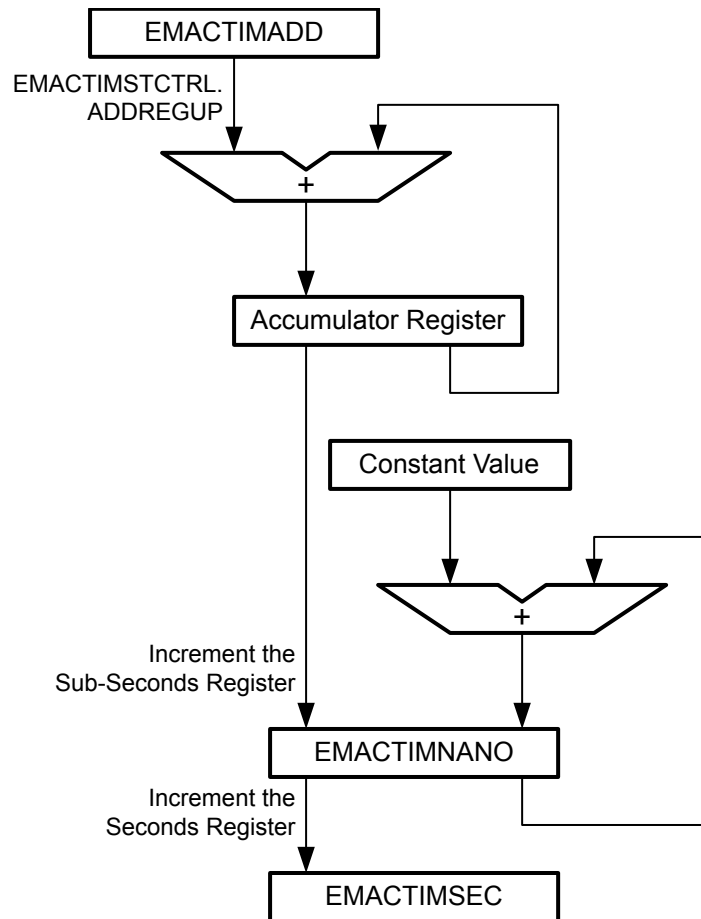

Note: The MOSC clock that feeds the PTP reference clock to the System Time Module must be 25 MHz because it is also clocks the integrated PHY module.

Initially, the Ethernet's slave clock (from the MOSC) is adjusted with a compensation value (as described in the previous paragraph) which is written to the Timestamp Addend Register ($TSAR$) field in the **EMACTIMADD** register. This value is calculated as: $\text{FreqCompensationValue}_0 = TSAR = 2^{32} / \text{FreqDivisionRatio}$.

The System Time Module requires a 20-MHz PTP reference clock frequency to achieve 50-ns accuracy in the fine correction method. An addend must be written to the **Ethernet MAC Time Stamp Addend (EMACTIMADD)** register, offset 0x718 to achieve timing synchronization. If the MOSC clock source is 25 MHz, the frequency division ratio (FreqDivisionRatio) of the two is calculated as $25 \text{ MHz} / 20 \text{ MHz} = 1.25$. Hence, the default addend value to be set in the register is $2^{32} / 1.25$ or 0xC000.CCD0. If the reference clock drifts lower, to 24 MHz for example, the ratio is $24 / 20$, or 1.2 and the value to set in the addend register is $2^{32} / 1.20$, or 0xDFF1.65D2. The software must calculate the drift in frequency based on the Sync messages and update the **EMACTIMADD** register, at offset 0x718, accordingly.

If the master to slave delay is initially assumed to be the same for consecutive Sync messages, then the following steps can be used to calculate a new $TSAR$ value. The following algorithm calculates the precise master to slave delay value to allow for re-synchronization with the master using the new value:

1. At time MasterSyncTime_n the master sends the slave clock a Sync message. The slave receives this message when its local clock is SlaveClockTime_n and computes MasterClockTime_n as:
$$\text{MasterClockTime}_n = \text{MasterSyncTime}_n + \text{MasterToSlaveDelay}_n$$
2. The master clock count, $\text{MasterClockCount}_n$, for the current Sync cycle is given by:
$$\text{MasterClockCount}_n = \text{MasterClockTime}_n - \text{MasterClockTime}_{n-1}$$

This assumes that the $\text{MasterToSlaveDelay}$ is the same for Sync cycles n and $n-1$.
3. The slave clock count for current Sync cycle, SlaveClockCount_n is given by:
$$\text{SlaveClockCount}_n = \text{SlaveClockTime}_n - \text{SlaveClockTime}_{n-1}$$
4. The difference between the master and slave clock counts for the current Sync cycle, ClockDiffCount_n , is given by:
$$\text{ClockDiffCount}_n = \text{MasterClockCount}_n - \text{SlaveClockCount}_n$$
5. The frequency-scaling factor for the slave clock, FreqScaleFactor_n is given by:
$$\text{FreqScaleFactor}_n = (\text{MasterClockCount}_n + \text{ClockDiffCount}_n) / \text{SlaveClockCount}_n$$
6. The frequency compensation value, $\text{FreqCompensationValue}$, to be written in the TSAR field of the EACTIMADD register is:
$$\text{FreqCompensationValue}_n = \text{FreqScaleFactor}_n * \text{FreqCompensationValue}_{n-1}$$

In theory, this algorithm achieves lock in one Sync cycle; however, it may take several cycles, because of changing network propagation delays and operating conditions. This algorithm is self-correcting: if for any reason the slave clock is initially set to a value from the master that is incorrect, the algorithm corrects it at the cost of more Sync cycles.

23.3.5.2 Transmit Timestamping

The MAC captures a timestamp when the Start Frame Delimiter (SFD) of a frame is sent. The transmit frames are marked to indicate whether a timestamp should be captured for that frame and written to the extended transmit descriptors that support timestamping. The MAC returns the timestamp automatically to the corresponding transmit descriptor, thus connecting the timestamp with the specific PTP frame. The 64-bit timestamp information is written to the TDES6 and TDES7 fields.

23.3.5.3 Receive Timestamping

The MAC captures the timestamp of all received frames. The MAC does not process the received frames to identify the PTP frames in default timestamping mode (when Advanced Timestamp is disabled). The MAC gives the timestamp and the corresponding status to the TX/RX Controller along with the EOF data. The TX/RX Controller validates and indicates the availability of the timestamp so that the DMA can return the timestamp to the corresponding receive descriptor. The 64-bit timestamp information is written to the RDES6 and RDES7 fields. The timestamp is written only to the receive descriptor for which the Last Descriptor status field has been set to 1 (the EOF marker). When the timestamp is not available (for example, because of an RX FIFO overflow), an all '1s' pattern is written to the descriptors (RDES6 and RDES7), indicating that the timestamp is not correct. If timestamping is disabled, the DMA does not alter RDES6 or RDES7. RDES0[7] indicates whether the timestamp is updated in RDES6 and RDES7.

23.3.5.4 Timestamp Error Margin

According to the IEEE 1588 specifications, a timestamp must be captured at the SFD of the transmitted and received frames at the MAC interface. Because the reference timing source, MOSC, is taken as different from MAC reference clocks, a small error margin is introduced, because of the transfer of information across asynchronous clock domains. In the transmit path, the captured and reported timestamp has a maximum error margin of 2 PTP (MOSC) clocks. It means that the captured timestamp has the reference timing source (MOSC) value that is given within 2 clocks after the SFD has been transmitted to the PHY. Similarly, in the receive path, the error margin is 3 MAC reference clocks, plus up to 2 PTP clocks. The error margin of the three MAC reference clocks can be ignored by assuming that this constant delay is present in the system (or link) before the SFD data reaches the interface of MAC.

Note: The reference clock to the integrated PHY must be 25 MHz.

Note: When IEEE 1588 timestamping is enabled with internal timestamp, use a PTP clock frequency that is greater than 5 MHz. This is because the `SSINC` field in the `EMACSUBSECINC` register limits the PTP frequency that can be used to ~4 MHz.

23.3.5.5 IEEE 1588-2008 Advanced Timestamps

In addition to the basic timestamp features mentioned in IEEE 1588-2002 Timestamps, the Ethernet Controller supports the following advanced timestamp features defined in the IEEE 1588-2008 standard:

- Supports the IEEE 1588-2008 (version 2) timestamp format.
- Provides an option to take snapshot of all frames or only PTP type frames.
- Provides an option to take snapshot of only event messages.
- Provides an option to take the snapshot based on the clock type: ordinary, boundary, end-to-end, and peer-to-peer.
- Provides an option to select the node to be a master or slave clock.
- Identifies the PTP message type, version, and PTP payload in frames sent directly over Ethernet and sends the status.
- Provides an option to measure sub-second time in digital or binary format.

Peer-to-Peer Transparent Clock Message Support

The IEEE 1588-2008 version supports Peer-to-Peer PTP (Pdelay) message in addition to SYNC, Delay Request, Follow-up, and Delay Response messages. Figure 23-10 on page 1570 shows the method to calculate the propagation delay in clocks supporting peer-to-peer path correction.

Figure 23-10. Propagation Delay Calculation in Clocks Supporting Peer-to-Peer Path Correction

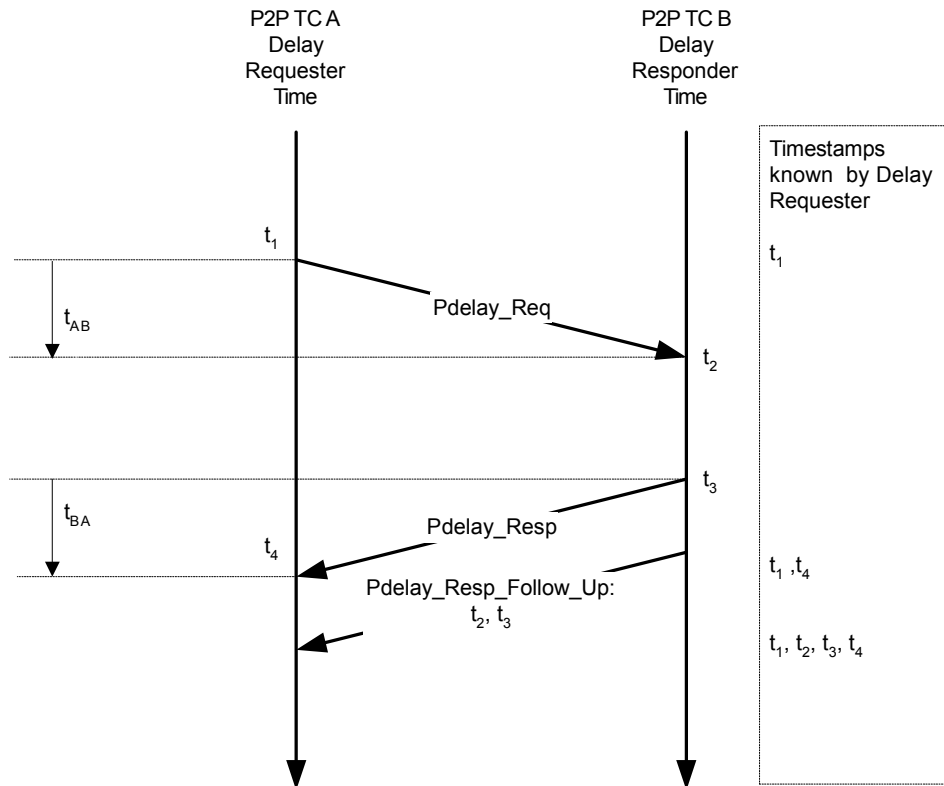

As shown in Figure 23-10 on page 1570, the propagation delay is calculated in the following way:

1. Port-1 issues a `Pdelay_Req` message and generates a timestamp, t_1 , for the `Pdelay_Req` message.
2. Port-2 receives the `Pdelay_Req` message and generates a timestamp, t_2 , for this message.
3. Port-2 returns a `Pdelay_Resp` message and generates a timestamp, t_3 , for this message.
To minimize errors because of any frequency offset between the two ports, Port-2 returns the `Pdelay_Resp` message as quickly as possible after the receipt of the `Pdelay_Req` message. The Port-2 returns any one of the following:
 - The difference between the timestamps t_2 and t_3 in the `Pdelay_Resp` message.
 - The difference between the timestamps t_2 and t_3 in the `Pdelay_Resp_Follow_Up` message.
 - The timestamps t_2 and t_3 in the `Pdelay_Resp` and `Pdelay_Resp_Follow_Up` messages respectively.
4. Port-1 generates a timestamp, t_4 , on receiving the `Pdelay_Resp` message.
5. Port-1 uses all four timestamps to compute the mean link delay.

Advanced Timestamp Supported Clock Types

The Advance Timestamp Module supports an ordinary clock as defined by the IEEE 1588-2008 standard. The characteristics of this clock is as follows:

- Sending and receiving of PTP messages. The timestamp snapshot can be controlled through the **Ethernet MAC Timestamp Control (EMACTIMSTCTRL)** register, offset 0x700. Timestamp snapshots can be for Sync messages.
- Maintaining the data sets such as timestamp values.

For an ordinary clock, snapshots can be taken of either version 1 or version 2 PTP types but not both. Selecting between the two is controlled by the `PTPVER2` bit of the **EMACTIMSTCTRL** register.

PTP Processing and Control

There are fields in an Ethernet Payload that the Ethernet Controller can use to detect the PTP packet type and control the snapshot to be taken. These fields are different depending on whether the PTP frames are:

- PTP frames over IPv4
- PTP frames over IPv6
- PTP frames over Ethernet

The `PTPIPv4`, `PTPIPv6` or `PTPETH` bits can be set depending on which PTP processing is required.

Reference Timing Source

The MAC supports the following reference timing source features defined in the IEEE 1588-2008 standard:

- 80-bit timestamp
- Fixed Pulse-Per-Second PPS0 Output
- Flexible Pulse-Per-Second PPS0 Output

80-Bit Timestamp

The MAC supports an 80-bit timestamp with a lengthened seconds integer portion which is 48-bits wide. The **Ethernet MAC System Time - Seconds (EMACTIMSEC)** register at offset 0x708 and the **Ethernet MAC System Time-Higher Word Seconds (EMACHWORDSEC)** register at offset 0x724 comprise the seconds count. The 32-bit **Ethernet MAC System Time - Nanoseconds (EMACTIMNANO)** register contains the fractional portion of the timestamp units of nanoseconds. The nanoseconds register supports the following two modes:

- Digital rollover mode: In digital rollover mode, the maximum value in the nanoseconds field is 0x3B9A_C9FF, that is, $(10e9-1)$ nanoseconds.
- Binary rollover mode: In binary rollover mode, the nanoseconds field rolls over and increments the seconds field after value 0x7FFF_FFFF. Accuracy is ~ 0.466 ns per bit.

Digital or binary rollover mode can be selected by programming the `DGTLBIN` bit of the **EMACTIMSTCTRL** register. Note that the timestamp maintained in the MAC is still 64-bits wide, but that the overflow to the upper 16-bits seconds register happens once in 130 years.

Fixed Pulse-Per-Second Output

The Ethernet MAC module supports a pulse-per-second output feature such that the signal, `EN0PPS`, can indicate one second intervals. The frequency of the `EN0PPS` output can be changed by setting the `PPSCTRL` bit field of the **Ethernet MAC PPS Control (EMACPPSCTRL)** register, offset 0x72C.

Flexible Pulse-Per-Second Output

The Ethernet MAC also provides the ability to control the following features of the `EN0PPS` output:

- Start or stop time
- The start point of a single pulse and the start and stop points of the pulse train in terms of a 64-bit system time. The **EMACTIMESEC** and **EMACTIMNANO** registers are used to program the start and stop time.
- The stop time can be programmed in advance of starting.
- The signal width. The rising edge and the corresponding falling edge of the `EN0PPS` output can be programmed in terms of number of units of sub-second increment value programmed in the **Ethernet MAC Sub-Second Increment (EMACSUBSECINC)** register, offset 0x704.
- The signal interval. The time between the rising edges of `EN0PPS` signal, in terms of number of units of sub-second increment value can be programmed in the **Ethernet MAC PPS0 Interval (EMACPPS0INTVL)** register, offset 0x760 . You can program the interval between pulses from 1 to $2^{32}-1$ units of sub-second increment value.
- Cancellation of the programmed `EN0PPS` start or stop request.
- Error indication if the start or stop time being programmed has already passed.

The start time can be programmed in the **EMACTARGSEC** and **EMACTARGNANO** registers. The `TRGTBUSY` bit in the **EMACTARGNANO** register indicates when the value is synchronized to the PTP clock domain. When this bit is clear, a new start time can be programmed, even before the earlier start time has elapsed. The start or stop time should be programmed with advanced system time to ensure proper `EN0PPS` signal output. If the application programs a start or stop time that has already elapsed, then the MAC sets an error status bit indicating the programming error. If enabled, the MAC also sets the Target Time Reached interrupt event. The application can cancel the start or stop request only if the corresponding start or stop time has not elapsed. If the time has elapsed, the cancel command has no effect.

For a flexible `EN0PPS` output, the **EMACPPS0INTVL** and **EMACPPS0WIDTH** registers can be configured. The `PPS0WIDTH` and `PPS0INT` fields are programmed in terms of granularity of system time, that is, number of the units of sub-second increment value. For example, to have a `EN0PPS` pulse width of 80 ns and interval of 120ns, with the PTP reference clock of 25MHz, you should program the width and interval to values 1 and 2, respectively. Note that the `PPS0WIDTH` and `PPS0INT` value must be programmed as one less than the required interval. Before giving the command to trigger a pulse or pulse train on the `EN0PPS` output, the interval and width of the PPS signal output should be programmed or updated.

Advanced Timestamp Transmit Path Functions

The only aspect of the transmit path that changes with advanced timestamp is the descriptor, which extends to 32-bytes long.

When you enable the advanced timestamp feature, the structure of the descriptor changes. The advanced timestamp feature is supported only through the enhanced descriptors format. The descriptor is 32-bytes long (eight words) and the snapshot of the timestamp is written in descriptor TDES6 and TDES7.

Advanced Timestamp Receive Path Functions

When the advanced timestamp feature is enabled, the MAC processes the received frames to identify valid PTP frames. The snapshot of the time sent to the application can be configured to:

- Enable snapshot for all frames
- Enable snapshot for IEEE 1588 version 2 or version 1 timestamp
- Enable snapshot for PTP frames transmitted directly over Ethernet or UDP-IP-Ethernet
- Enable timestamp snapshot for the received frame for IPv4 or IPv6
- Enable timestamp snapshot only for EVENT messages (SYNC, DELAY_REQ, PDELAY_REQ, or PDELAY_RESP)
- Enable the node to be a master or slave and select the snapshot type. This controls the type of messages for which snapshots are taken

The MAC provides the timestamp, along with EOF to the TX/RX Controller. The DMA returns the timestamp inside the corresponding receive descriptor.

23.3.6 Frame Filtering

The following types of filtering are available for receive frames:

- Source Address (SA) or Destination Address (DA) filtering
- VLAN Filtering

The frame filtering supports a sequence where the packet is not forwarded to VLAN filtering if it does not pass the SA or DA filtering first.

23.3.6.1 VLAN Filtering

The Ethernet MAC provides VLAN Tag Perfect Filtering and VLAN Tag Hash Filtering. In VLAN tag perfect filtering, the MAC compares the VLAN tag of the received frame and provides the VLAN frame status to the application. Based on the programmed mode of the `ETV` bit in the **EMACVLANTG** register, the MAC compares the lower 12 bits or all 16 bits of the received VLAN tag to determine the perfect match. If VLAN tag perfect filtering is enabled, the MAC forwards the VLAN-tagged frames along with VLAN tag match status and drops the VLAN frames that do not match. Inverse matching for VLAN frames can also be enabled by setting the `VTIM` bit of the **Ethernet MAC VLAN Tag (EMACVLANTG)** register, offset 0x01C. In addition, matching of S-VLAN tagged frames along with the default C-VLAN tagged frames can be enabled by setting the `ESVL` bit of the **EMACVLANTG** register. The VLAN frame status bit (Bit 10 of `RDES0`) indicates the VLAN tag match status for the matched frames.

Note: The Source or Destination Address filter has precedence over the VLAN tag filters. A frame which fails the Source or Destination Address filter is dropped irrespective of the VLAN tag filter results.

The MAC provides VLAN tag hash filtering with a 16-bit Hash table. The MAC performs the VLAN hash matching based on the V_{THM} bit of the **EMACVLANTG** register. If the V_{THM} bit is set, the most significant four bits of VLAN tag's CRC-32 are used to index the content of the **Ethernet MAC VLAN Hash Table (EMACVLANHASH)** register, offset 0x588. A value of 1 in the **EMACVLANHASH** register, corresponding to the index, indicates that the VLAN tag of the frame matched and the packet should be forwarded. A value of 0 indicates that VLAN-tagged frame should be dropped. The MAC also supports the inverse matching of the VLAN frames. In the inverse matching mode, when the VLAN tag of a frame matches the perfect or hash filter, the packet should be dropped. If the VLAN perfect and VLAN hash match are enabled, a frame is considered as matched if either the VLAN hash or the VLAN perfect filter matches. When inverse match is set, a packet is forwarded only when both perfect and hash filters indicate mismatch. Table 23-18 on page 1574 shows the different possibilities for VLAN matching and the final VLAN match status. When the R_A bit of the **EMACFRAMEFLTR** register is set, all frames are received and the VLAN match status is indicated in Bit 10 of Receive Descriptor word 0 (RDES0). When the R_A bit is not set and the V_{TFE} bit in the **EMACFRAMEFLTR** register is set, the frame is dropped if the final VLAN match status is fail. In Table 23-18 on page 1574, value X means that this column can have any value. When the V_L field is programmed to 0x0 in **EMACVLANTG** register, all VLAN-tagged frames are considered as perfect matched but the status of the VLAN hash match depends on the VLAN hash enable (V_{THM}) bit and VLAN inverse filter (V_{TIM}) bit.

Table 23-18. VLAN Match Status

VLAN ID (V_L field)	VLAN Perfect Filter Match Status (V_{PF})	VLAN HASH Enable bit (H_{PF} bit in EMACFRAMEFLTR)	VLAN Hash Filter Match Status (V_{THM})	VLAN Inverse Filter Bit (V_{TIM})	Final VLAN Match Status
VL = 0	Pass	0	X	X	Pass
	Pass	1	X	0	Pass
	Pass	1	Fail	1	Pass
	Pass	1	Pass	1	Fail
VL !=0	Pass	X	X	0	Pass
	Fail	0	X	0	Fail
	Fail	1	Fail	0	Fail
	Fail	1	Pass	0	Pass
	Fail	0	X	1	Pass
	Pass	X	X	1	Fail
	Fail	1	Pass	1	Fail
Fail	1	Fail	1	Pass	

23.3.7 Source Address, VLAN, and CRC Insertion, Replacement or Deletion

The MAC supports the following functions for transmit frames:

- Source Address Insertion or replacement
- VLAN Insertion, Replacement or Deletion
- CRC Replacement

23.3.7.1 Source Address Insertion or Replacement

Software can use the SA insertion or replacement feature to instruct the MAC to do the following for transmit frames:

- Insert the content of the MAC Address Registers in the SA field.
- Replace the content of the SA field with the content of the MAC Address Registers.

The software can enable the SA insertion or replacement for all transmitted frames or selective frames:

- To enable SA insertion or replacement feature for all frames, program the `SADDR` field of the **Ethernet MAC Configuration (EMACCFG)** register.
- To enable SA insertion or replacement for selective frames, program the SA Insertion Control field (TDES1 Bits [31:29]) in the first transmit descriptor of the frame. When Bit 31 of TDES1 is set, the SA Insertion Control field indicates insertion or replacement by MAC Address1 registers. When Bit 31 of TDES1 is reset, it indicates insertion or replacement by MAC Address 0 registers.

When SA insertion is enabled, the application should ensure that the frames that are sent to the MAC do not have the SA field. The MAC does not check the presence of SA field in the transmit frame and just inserts the content of MAC Address Registers in the SA field. Similarly, when SA replacement is enabled, the application should ensure that the frames that are sent to the MAC have the SA field. The MAC just replaces the six bytes, following the Destination Address field in the transmit frame, with the content of the MAC Address Registers.

23.3.7.2 VLAN Insertion, Replacement or Deletion

The software can use the VLAN insertion, replacement, or deletion feature to instruct the MAC to do the following for transmit frames:

- Insert or replace the VLAN Type field (C-VLAN or S-VLAN indicated by the `CSVL` bit of the **Ethernet MAC VLAN Tag Inclusion or Replacement (EMACVLNINCREP)**, MAC offset 0x584) and the VLAN Tag field in the transmit frame with the `VLT` field of the **EMACVLNINCREP** register.
- Delete the VLAN Type and VLAN Tag fields in the transmit frame.

The software can enable the VLAN insertion, replacement, or deletion feature for all transmitted frames or selective frames. To enable this function for all transmit frames, configure the `VLT` field in the **EMACVLNINCREP** register.

When VLAN replacement or deletion is enabled, the MAC checks the presence of the VLAN Type field (0x8100 or 0x88a8), after the Destination address (DA) and SA fields, in the transmit frame. The replace or delete operation does not occur if the VLAN Type field is not detected in the two bytes following the DA and SA fields. However, when VLAN insertion is enabled, the MAC does not check the presence of VLAN Type field in the transmit frame and just inserts the VLAN Type and VLAN Tag fields.

23.3.7.3 CRC Replacement

The software can use the CRC replacement feature to instruct the MAC to replace the FCS field in the transmit frame with the CRC computed by the MAC. This feature works on a per-frame basis. The CRC replacement control field in the Transmit Descriptor Word 0 (TDES0) can be programmed to enable this for a frame. This feature is valid only when the Disable CRC control (Bit 27 of TDES0) is enabled. If SA or VLAN insertion control is enabled, the MAC appends or replaces the FCS field with the computed CRC when Disable CRC Control is enabled or disabled, respectively.

Table 23-19. CRC Replacement Based on Bit 27 and Bit 24 of TDES0

Bit 27 (DC)	Bit 24 (CRCR)	Description
0	X	Append CRC When DC= 0, the MAC appends the computed CRC irrespective of the CRCR setting.
1	1	Replace CRC
1	0	No operation (user has appended CRC)

23.3.8 Checksum Offload Engine

Communication protocols such as TCP and UDP implement checksum fields, which help determine the integrity of data transmitted over a network. Because the most widespread use of Ethernet is to encapsulate TCP and UDP over IP datagrams, the MAC Checksum Offload Engine (COE) supports checksum calculation and insertion in the transmit path, and error detection in the receive path.

23.3.8.1 Transmit Checksum Offload Engine

The checksum for TCP, UDP, or ICMP is calculated over a complete frame, and then inserted into its corresponding header field. Because of this requirement this function is enabled only when the TX FIFO is configured for the store-and-forward mode (the `TSF` bit is set in the `EMACDMAOPMODE` register).

Note: The TX FIFO must be deep enough to store a complete frame before the frame is transferred to the MAC when the checksum offload is being used. If space is not available to accept the programmed burst length of data, the TX/RX Controller starts reading to avoid deadlock. When reading starts, the checksum offload fails and the consequently all succeeding frames may be corrupted because of improper recovery. Therefore, checksum insertion must only be enabled in frames that are less than $[2048 - ((PBL + 3) * 4)]$ bytes in size, where PBL is the Programmable Burst Length field in the `EMACDMABUSMOD` register.

23.3.8.2 IP Header Checksum Engine

In IPv4 datagrams, the integrity of the header fields is indicated by the 16-bit Header Checksum field (the eleventh and twelfth bytes of the IPv4 datagram). The checksum offload engine detects an IPv4 datagram when the Ethernet frame's Type field has the value 0x0800 and the IP datagram's Version field has the value 0x4. The input frame's checksum field is ignored during calculation and replaced with the calculated value. IPv6 headers do not have a checksum field. Therefore, the checksum offload does not modify the IPv6 header fields.

The result of this IP header checksum calculation is indicated by the IP Header Error status bit in the Transmit status (Bit 16 in TDES0). This status bit is set whenever the values of the Ethernet Type field and the IP header's Version field are not consistent, or when the Ethernet frame does not have enough data, as indicated by the IP header Length field. In other words, this bit is set when an IP header error is asserted under the following circumstances:

- For IPv4 datagrams:
 - The received Ethernet type is 0x0800, but the IP header's Version field is not equal to 0x4.
 - The IPv4 Header Length field indicates a value less than 0x5 (20 bytes).
 - The total frame length is less than the value given in the IPv4 Header Length field.
- For IPv6 datagrams:

- The Ethernet type is 0x86dd but the IP header Version field is not equal to 0x6.
- The frame ends before the IPv6 header (40 bytes) or extension header (as given in the corresponding Header Length field in an extension header) is completely received.

If the checksum offload engine detects an IP header error, it still inserts an IPv4 header checksum if the Ethernet Type field indicates an IPv4 payload.

23.3.8.3 Receive Checksum Offload Engine

Both IPv4 and IPv6 frames in the received Ethernet frames are detected and processed for data integrity. The receive checksum feature can be enabled by setting the `IPC` bit of the **Ethernet MAC Configuration (EMACCFG)** register. The EMAC receiver identifies IPv4 or IPv6 frames by checking for value 0x0800 or 0x86DD, respectively, in the received Ethernet frames' Type field. This identification also applies to single VLAN-tagged frames. The offline receive checksum engine calculates IPv4 header checksums and checks that they match the received IPv4 header checksums. The IP Header Error bit is set for any mismatch between the indicated payload type (Ethernet Type field) and the IP header version, or when the received frame does not have enough bytes, as indicated by the Length field of the IPv4 header or when fewer than 20 bytes are available in an IPv4 or IPv6 header. This engine also identifies a TCP, UDP, or ICMP payload in the received IP datagrams (IPv4 or IPv6) and calculates the checksum of such payloads properly, as defined in the TCP, UDP, or ICMP specifications. This engine includes the TCP, UDP, or ICMPv6 pseudo-header bytes for checksum calculation and checks whether the received checksum field matches the calculated value. The result of this operation is given as a Payload Checksum Error bit in the receive status word. This status bit is also set if the length of the TCP, UDP, or ICMP payload does not match the expected payload length given in the IP header.

23.3.9 MAC Management Counters

The MAC Management Counters (MMC) module maintains a set of registers for gathering statistics on the received and transmitted frames. The register set includes a control register for controlling the behavior of the registers, two 32-bit registers containing interrupts generated (one for receive and one for transmit), and two 32-bit registers containing masks for the Interrupt register (one for receive and one for transmit). The MMC counters are free running and start counting when a corresponding frame is received or transmitted. The MMC counter registers provided are as follows:

- **Ethernet MAC Transmit Frame Count for Good and Bad Frames (EMACTXCNTGB)**
- **Ethernet MAC Transmit Frame Count for Frames Transmitted after Single Collision (EMACTXCNTSCOL)**
- **Ethernet MAC Transmit Frame Count for Frames Transmitted after Multiple Collisions (EMACTXCNTMCOL)**
- **Ethernet MAC Transmit Octet Count Good (EMACTXOCTCNTG)**
- **Ethernet MAC Receive Frame Count for Good and Bad Frames (EMACRXCNTGB)**
- **Ethernet MAC Receive Frame Count for CRC Error Frames (EMACRXCNTCRCERR)**
- **Ethernet MAC Receive Frame Count for Alignment Error Frames (EMACRXCNTALGNERR)**
- **Ethernet MAC Receive Frame Count for Good Unicast Frames (EMACRXCNTGUNI)**

23.3.10 Power Management Module

The power management (PMT) module supports the reception of network remote wake-up frames and AMD Magic Packet™ frames. The PMT module does not perform the clock gate function, but generates interrupts for remote wake-up frames and magic packets that the MAC receives.

When the application enables the power-down mode in the PMT module by setting the `PWRDWN` bit in the **Ethernet MAC PMT Control and Status Register (EMACPMTCTLSTAT)** register, MAC offset 0x02C, the MAC drops all received frames and does not forward any frame to the TX/RX Controller Rx FIFO or the application. The MAC comes out of the power-down mode only when a magic packet or a remote wake-up frame is received and the corresponding detection is enabled.

23.3.10.1 Remote Wake-Up

The Remote Wake-Up register bank is made up of eight 32-bit registers. It is loaded by writing the **Ethernet MAC Remote Wake-Up Frame Filter (EMACRWUFF)** register eight times. To load values in the **EMACRWUFF** register, the entire register must be written. The first write is assigned to register 0 of the bank, then register 1 and so on. The **Ethernet MAC Remote Wake-Up Frame Filter (EMACRWUFF)** register is read the same way. The current pointer value of the bank is updated in the Remote Wake-Up FIFO Pointer (`RWKPTR`) field of the **Ethernet MAC PMT Control and Status (EMACPMTCTLSTAT)** register.

Figure 23-11. Wake-Up Frame Filter Register Bank

Filter 0 Byte Mask							
Filter 1 Byte Mask							
Filter 2 Byte Mask							
Filter 3 Byte Mask							
RSVD	Filter 3 Command	RSVD	Filter 2 Command	RSVD	Filter 1 Command	RSVD	Filter 0 Command
Filter 3 Offset		Filter 2 Offset		Filter 1 Offset		Filter 0 Offset	
Filter 1 CRC - 16				Filter 0 CRC - 16			
Filter 3 CRC - 16				Filter 2 CRC - 16			

Filter n Byte Mask

The Filter n Byte Mask registers of the Remote Wake-Up register define the bytes of the frame that are examined by filter n (0, 1, 2, and 3) in order to determine whether or not a frame is a remote wake-up frame. The most significant bit (bit 31) of each mask must be zero. Bits [30:0] are the Byte Mask. If bit, j, of the Byte Mask is set, then the CRC block processes the Filter n Offset + j of the incoming frame; otherwise Filter n Offset + j is ignored.

Filter n Command

The 4-bit Filter n Command field controls the Filter n operation in the following way:

- Filter n Command Bit 3 specifies the address type of the pattern. When the bit is set, the pattern applies to only multicast frames; when the bit is reset, the pattern applies only to unicast frame.
- Filter n Command Bit 2 and Bit 1 are reserved.
- Filter n Command Bit 0 is the enable for Filter n. If bit 0 is not set, filter n is disabled.

Filter n Offset

The Filter n Offset register defines the offset (within the frame) from which the filter n examines the frames. This 8-bit pattern offset is the offset for the filter n first byte to be examined. The minimum allowed offset is 12, which refers to the 13th byte of the frame. The offset value 0 refers to the first byte of the frame.

Filter n CRC-16

The Filter n CRC-16 register contains the CRC_16 value calculated from the pattern and the byte mask programmed to the wake-up filter register block.

23.3.10.2 Remote Wake-Up Frame Detection

When the MAC is in sleep mode and the remote wake-up frame enable bit, `WUPFREN`, is set in the **Ethernet MAC PMT Control and Status (EMACPMCTLSTAT)** register, the normal operation is resumed after a remote wake-up frame is received. The application writes all eight wake-up filter registers, by performing eight sequential writes to the **Ethernet MAC Remote Wake-Up Frame Filter (EMACRWUFF)** register. The Power Management (PMT) block supports four programmable filters that allow support of different receive frame patterns. If the incoming frame passes the address filtering of Filter Command, and if Filter CRC-16 matches the CRC of the incoming pattern, then the MAC identifies the frame as wake-up frame. The Filter Offset determines the offset from which the frame is to be examined. The Filter Byte Mask determines which bytes of the frame must be examined. The 31st bit of Byte Mask must be set to zero. The remote wake-up CRC block determines the CRC value that is compared with Filter CRC-16. The remote wake-up frame is checked only for length error, FCS error, dribble bit error, MII error, and collision. In addition, the remote wake-up frame is checked to ensure that it is not a runt frame. Even if the remote wakeup frame is more than 512 bytes long, if the frame has a valid CRC value, it is considered valid. The remote wake-up frame detection is updated in the **Ethernet MAC PMT Control and Status (EMACPMCTLSTAT)** register for every remote wake-up frame received. If the `PMT` interrupt is enabled in the **Ethernet MAC Interrupt Mask (EMACIM)** register, a `PMT` interrupt is asserted and the **EMACPMCTLSTAT** register can be read to determine reception of a remote wake-up frame.

23.3.10.3 Magic Packet Detection

The magic packet frame is based on a method that uses Advanced Micro Device's magic packet technology to power up the sleeping device on the network. The MAC receives a specific packet of information, called a magic packet, addressed to the node on the network. The MAC checks only those magic packets that are addressed to the MAC or a broadcast address to determine whether these packets meet the wake-up requirements. The magic packets that pass the address filtering (unicast or broadcast) are checked to determine whether they meet the remote wake-up frame data format of 6 bytes of all ones followed by a MAC Address appearing 16 times. The application enables the magic packet wake-up by setting the magic packet enable bit, `MGKPKTEN`, of the **Ethernet MAC PMT Control and Status (EMACPMCTLSTAT)** register. The power management block constantly monitors each frame addressed to the node for a specific magic packet pattern. Each frame received is checked for a `0xFFFF.FFFF.FFFF` pattern following the destination and source address field. The power management block then checks the frame for 16 repetitions of the MAC address without any breaks or interruptions. In case of a break in the 16 repetitions of the address, the PMT block again

scans the 0xFFFF.FFFF.FFFF pattern in the incoming frame. The 16 repetitions can be anywhere in the frame, but must be preceded by the synchronization stream (0xFFFF.FFFF.FFFF). The device can also accept a multicast frame, as long as the 16 duplications of the MAC address are detected. If the MAC address of a node is 0x0011.2233.4455, then the MAC scans for the following data sequence:

```
Destination Address Source Address ..... FF FF FF FF FF FF
00 11 22 33 44 55 00 11 22 33 44 55 00 11 22 33 44 55 00 11 22 33 44 55
00 11 22 33 44 55 00 11 22 33 44 55 00 11 22 33 44 55 00 11 22 33 44 55
00 11 22 33 44 55 00 11 22 33 44 55 00 11 22 33 44 55 00 11 22 33 44 55
00 11 22 33 44 55 00 11 22 33 44 55 00 11 22 33 44 55 00 11 22 33 44 55 ...CRC
```

The magic packet detection is updated in the **EMACPMTCTLSTAT** register for the received magic packet. If the **PMT** interrupt is enabled in the **Ethernet MAC Interrupt Mask (EMACIM)** register, a **PMT** interrupt is asserted and the **EMACPMTCTLSTAT** register can be read to determine whether a magic packet frame has been received.

23.3.10.4 Power Management Interrupts

The **PMT** interrupt signal can be asserted when a valid remote wake-up frame or magic packet is received. The **PMT** interrupt signal restores the application clock and TX clock to the MAC. When the **Ethernet MAC PMT Control and Status (EMACPMTCTLSTAT)** register is read, the **PMT** interrupt is cleared in the **EMACRIS** register at least after four clock cycles of RX clock. When software resets the **PWRDWN** bit in the **Ethernet MAC PMT Control and Status (EMACPMTCTLSTAT)** register, the MAC comes out of the power-down mode, but this event does not generate a **PMT** interrupt.

23.3.10.5 Power-Down/Wake-Up Sequence

The recommended power-down and wake-up sequence is as follows:

1. Disable the Transmit DMA (if applicable) and wait for any previous frame transmissions to complete. These transmissions can be detected when **TI** is set in the **Ethernet MAC DMA Interrupt Status (EMACDMARIS)** register.
2. Disable the MAC transmit and receive state machine by clearing the **TE** and **RE** bits in the **Ethernet MAC Configuration (EMACCFG)** register.
3. Wait until the RX DMA empties all the frames from the Rx FIFO to system memory by polling the **RXF** field of the **Ethernet MAC Status (EMACSTATUS)** register.
4. Enable a power management mode by setting the magic packet, global unicast or remote wake-up enable bit in the **EMACPMTCTLSTAT** register.
5. Enable the MAC receive state machine in the **EMACCFG** register and enter the Power-Down mode by setting the **PWRDWN** bit in the **EMACPMTCTLSTAT** register.
6. On receiving a valid remote wake-up frame, the **PMT** interrupt is set in the **EMACRIS** register and the Ethernet MAC exits the Power-Down mode.
7. Read the **EMACPMTCTLSTAT** register to clear the **PMT** interrupt, then enable the other modules in the system and resume normal operation.

23.3.11 Serial Management Interface

The Ethernet MAC has the ability to program the integrated PHY through internal serial MDIO and MDC signals. The MDC signal is a 2.5 MHz clock that is sourced from system clock and then divided down to the required frequency by programming the `CR` field in the **Ethernet MAC MII Address (EMACMIIADDR)** register. To access the integrated PHY, the `PLA` field in the **EMACMIIADDR** register must be 0x0.

23.3.12 Interrupt Configuration

Interrupts can be generated from the MAC as a result of various events in the MAC and sub-modules. MAC interrupts are enabled or disabled in the **Ethernet MAC Interrupt Mask (EMACIM)** register, MAC offset 0x03C. Each interrupt event can be masked by setting the corresponding mask bit in the **EMACIM** register.

The interrupt register bits in the **Ethernet MAC Raw Interrupt Status (EMACRIS)** register only indicate the sub-module from which the event is reported. The application must read the corresponding status registers to clear the interrupt.

23.4 Ethernet PHY

The integrated PHY supports 10Base-T and 100Base-TX signaling. It integrates all the physical-layer functions needed to transmit and receive data on standard twisted-pair cables. The PHY directly interfaces to the integrated Media Access Controller (MAC).

The Ethernet PHY uses mixed-signal processing to perform equalization, data recovery, and error correction to achieve robust operation over CAT5 twisted-pair wiring. It not only meets the requirements of IEEE 802.3, but maintains high margins in terms of alien cross-talk. The following highlights the features of the PHY module:

- Cable Diagnostics
- Programmable Fast Link Down Modes
- Auto-MDIX for 10/100Mbps
- Energy Detection Mode
- Serial Management Interface
- IEEE 802.3u Auto-Negotiation and Parallel Detection
- IEEE 802.3u ENDEC, 10Base-T Transceivers and Filters
- IEEE 802.3u PCS, 100Base-TX Transceivers
- Integrated ANSI X3.263 Compliant TP-PMD Physical Sublayer with Adaptive Equalization and Baseline Wander Compensation
- Three programmable LEDs that support detection of Link OK, 10/100Mbps activity, TX/RX transfers, collisions and full duplex mode

23.4.1 Integrated PHY Block Diagram

The following figure shows the internal PHY integration. Note that the reference clock input comes from an external 25 MHz \pm 50 ppm crystal or oscillator connected to the MOSC signals.

Figure 23-12. Integrated PHY Diagram

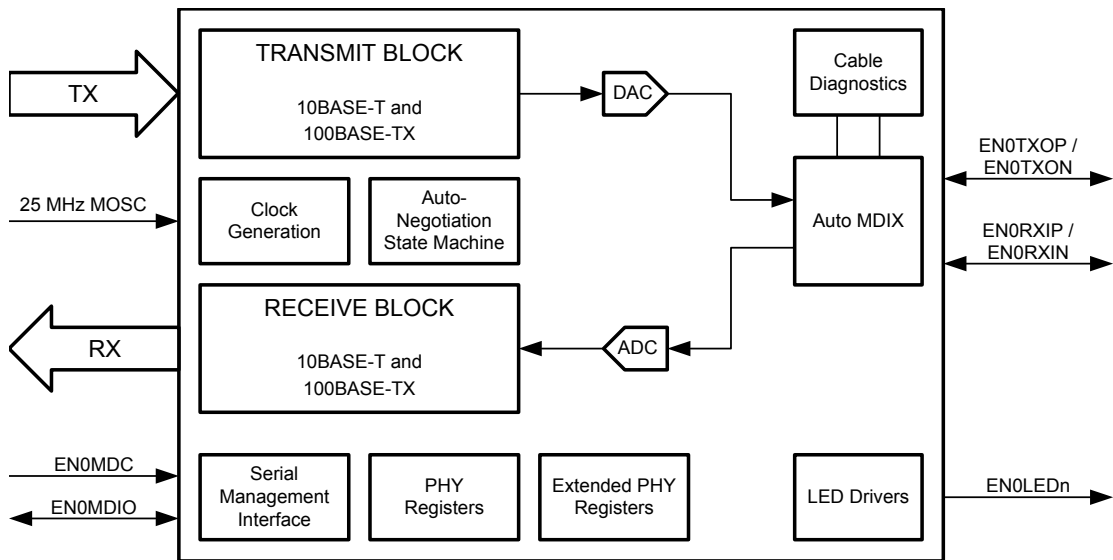

23.4.2 Functional Description

The following sections describe the functional characteristics of the integrated PHY.

23.4.2.1 Auto-Negotiation

The Ethernet PHY can auto-negotiate to operate in 10Base-T or 100Base-TX. When the Ethernet PHY is enabled or on the deassertion of software reset, the **Ethernet MAC Peripheral Configuration Register (EMACPC)** register, offset 0xFC4, is configured such that auto-negotiation is enabled and the auto negotiation mode (`ANMODE`) bit field is programmed to 10Base-T, Half/Full-Duplex 100Base-TX, Half/Full-Duplex. With auto-negotiation enabled, the PHY negotiates with the link partner to determine the speed and duplex mode with which to operate. If the link partner is unable to auto-negotiate, the PHY goes into parallel-detect mode to determine the speed of the link partner. Under parallel-detect mode, the duplex mode is fixed at half-duplex. The PHY supports four different Ethernet protocols (10Mbps Half-Duplex, 10Mbps Full-Duplex, 100Mbps Half-Duplex, and 100Mbps Full-Duplex). Auto-Negotiation selects the highest performance protocol based on the advertised ability of the Link Partner. If a different auto-negotiation configuration is required other than the reset initialization values, the application can customize the configuration of the `ANEN` bit and `ANMODE` bit field as described in “Custom Configuration” on page 1590. The values of `ANEN` and `ANMODE` determine whether the PHY is forced into a specific mode, or if Auto-negotiation advertises a specific ability (or abilities) as listed in Table 23-20 on page 1582 and Table 23-21 on page 1583:

Table 23-20. Forced Mode Configurations

ANEN value	ANMODE	Forced Mode
0	0x0	10Base-T, Half-Duplex
0	0x1	10Base-T, Full-Duplex
0	0x2	100Base-TX, Half-Duplex
0	0x3	100Base-TX, Full-Duplex

Table 23-21. Advertised Mode Configurations

ANEN value	ANMODE	Advertised Mode
1	0x0	10Base-T, Half/Full-Duplex
1	0x1	100Base-TX, Half/Full-Duplex
1	0x2	10Base-T, Half Duplex 100Base-TX, Half Duplex
1	0x3	10Base-T, Half/Full-Duplex 100Base-TX, Half/Full-Duplex

23.4.2.2 Auto-MDIX

The PHY automatically determines whether or not it needs to cross over between pairs so that an external crossover cable is not required. If the PHY communicates with a device that implements MDI/MDIX crossover, a random algorithm as described in IEEE 802.3 determines which device performs the crossover. Auto-MDIX is enabled by default at reset. If a different auto-MDIX configuration is required other than the reset initialization, the application can customize the configuration as described in “Custom Configuration” on page 1590. Neither Auto-Negotiation nor Auto-MDIX is required to be enabled in forcing crossover of the MDI pairs. Auto-MDIX can be used in the forced 100Base-TX mode. Because in modern networks all the nodes are 100Base-TX, having the Auto-MDIX working in the forced 100Base-TX mode resolves the link faster without the need for the long Auto-Negotiation period.

23.4.2.3 Isolate Mode

The PHY can be put into Isolate mode by writing `ISOLATE` bit of the **Ethernet PHY Basic Mode Control - MR0 (EPHYBMCR)** register, address 0x000. When in the Isolate mode, the PHY does not respond to packet data present at the internal interface to the Ethernet MAC. When in isolate mode, the PHY continues to respond to all management transactions and the PMD output pair does not transmit packet data, but continues to source 100Base-TX scrambled idles or 10Base-T normal link pulses. The PHY can auto-negotiate or parallel detect on the receive signal at the PMD input pair. A valid link can be established for the receiver even when the PHY is in Isolate mode.

23.4.2.4 LED Interface

The PHY supports three configurable Light Emitting Diode (LED) pins to indicate link status of a port. The **Ethernet PHY LED Configuration - MR37 (EPHYLEDCFG)** register, address 0x025 can be used to assign different functions to each LED. Each LED can be configured to be active during one of these events:

- Link OK (0x0)
- RX/TX Activity (0x1)
- TX Activity (0x2)
- RX Activity (0x3)
- Collision (0x4)
- 100-BASE TX speed (0x5)
- 10-Base TX speed (0x6)
- Full Duplex (0x7)
- Link OK/Blink on TX/RX Activity (0x8)

At reset, LED0 is initialized to display Link OK and LED1 and LED 2 are initialized to the RX/TX activity encoding. The blink rate of the LEDs can be set by programming the `BLINKRATE` bit field of the **Ethernet PHY LED Control - MR24 (EPHYLEDCR)** register, address 0x018

23.4.2.5 PHY Address

The integrated PHY's address is 0x00. To access the integrated PHY registers through the internal MAC's MDIO interface, the `PLA` bit field of the **Ethernet MAC MII Address (EMACMIIADDR)** register must be 0x00 and the `MII` field should be programmed to the desired address value.

23.4.2.6 Serial Management Interface

The Ethernet MAC module has the capability of programming the integrated PHY registers and extended registers through an internal Serial Management Interface (SMI). The SMI is compatible with IEEE802.3-2002 clause 22.

The SMI includes an MDC management clock input and management MDIO data pin to the Ethernet PHY. The internal MDC clock is sourced by the system clock and then divided down to the required 2.5 MHz maximum clock frequency by setting the `CR` bit in the **Ethernet MAC MII Address (EMACMIIADDR)** register. The MDC is not expected to be continuous, and can be turned off by the external management entity when the bus is idle. The MDIO is sourced by the integrated MAC and by the PHY. The data on the MDIO pin is latched on the rising edge of the MDC clock. The PHY's physical address is 0x00.

23.4.2.7 Extended Address Space Access

The PHY SMI function supports read/write accesses to the extended register set using **Ethernet PHY Register Control - MR13 (EPHYREGCTL)** register and the **Ethernet PHY Address or Data - MR14 (EPHYADDAR)** registers. Accessing the standard register set, MDIO registers 0 to 31, can be performed using the normal direct MDIO access or the indirect method, except for the **EPHYREGCTL (0x00D)** and the **EPHYADDAR (0x00E)** which can be accessed only using the normal MDIO transaction. The SMI function ignores indirect accesses to these registers.

The **EPHYREGCTL** register is the MDIO Manageable MMD access control. In general, register **EPHYREGCTL[4:0]** is the device address `DEVAD` that directs any accesses of **EPHYADDAR** register to the appropriate MMD. Specifically, the PHY uses the vendor specific `DEVAD[4:0] = 0xF` for accesses. All accesses through registers **EPHYREGCTL** and **EPHYADDAR** registers should use this `DEVAD`. Transactions with other `DEVAD` are ignored. The **EPHYREGCTL[15:14]** register holds the access function:

- **EPHYREGCTL[15:14] = 0x0**: A write to **EPHYADDAR** modifies the extended register set address register. This address register must be initialized in order to access any of the registers within the extended register set.
- **EPHYREGCTL[15:14] = 0x1**: A read/write to **EPHYADDAR** operates on the register within the extended register set selected (pointed to) by the value in the address register. The address register contents (pointer) remain unchanged.
- **EPHYREGCTL[15:14] = 0x2**: A read/write to **EPHYADDAR** operates on the register within the extended register set selected (pointed to) by the value in the address register. After that access is complete, for both reads and writes, the value in the address register is incremented.
- **EPHYREGCTL[15:14] = 0x3**: A read/write to **EPHYADDAR** operates on the register within the extended register set selected (pointed to) by the value in the address register. After that access is complete, for write accesses only, the value in the address register is incremented. For read accesses, the value of the address register remains unchanged.

The following sections describe how to perform operations on the extended register set using the **EPHYREGCTL** and **EPHYADDAR** registers.

Write to PHY Registers

The following describes the steps to write to a PHY register.

1. Check the **MIIB** bit in the **EMACMIADDR** register to identify if the MII interface is busy. When the **MIIB** bit is 0, the MII interface is available to write to the PHY registers.
2. Write the data to be written to the PHY register in the **EMACMIIDATA** register.
3. Initiate write by programming the **EMACMIADDR** register fields as follows:
 - **PLA**: Physical Layer Address of the PHY. The integrated PHY's address is 0x0.
 - **MII**: Address of the PHY register to be written.
 - **CR**: Clock Reference for the MDIO interface.
 - **MIIW**: Write Initiation. This bit is set to 1 to indicate that a write operation is to be executed.
 - **MIIB**: MII Busy. This bit is set to 1 to indicate that the MII is now busy with a write operation. The EMAC clears this bit when the write has been transmitted.

Write to Extended PHY Registers

The following describes the steps to write to an extended PHY register.

1. Check the **MIIB** bit in the **EMACMIADDR** register to identify if the MII interface is busy. When the **MIIB** bit is 0, the MII interface is available to write to the PHY registers.
2. The **EMACMIIDATA** register should be written with the value to be passed into the **EPHYREGCTL** register. The **EPHYREGCTL** register is used for extended PHY register accesses. The **DEVAD** field of the **EPHYREGCTL** register identifies the device address, which is 0x1F, for the integrated PHY. The **FUNC** field of the **EPHYREGCTL** register should be set to 0x0 to indicate a write to an extended register address.
3. Initiate write by programming the **EMACMIADDR** register fields as follows:
 - **PLA**: Physical Layer Address of the PHY. The integrated PHY's address is 0x0.
 - **MII**: Address of the PHY register to be written. In this case, it should be the address of the **EPHYREGCTL** register, 0xD.
 - **CR**: Clock Reference for the MDIO interface.
 - **MIIW**: Write Initiation. This bit is set to 1 to indicate that a write operation is to be executed.
 - **MIIB**: MII Busy. This bit is set to 1 to indicate that the MII is now busy with a write operation. The EMAC clears this bit when the write has been transmitted.
4. Check the **MIIB** bit in the **EMACMIADDR** register to identify if the MII interface is busy. When the **MIIB** bit is 0, the MII interface is available to write to the PHY registers.

5. The **EMACMIIDATA** register should be written with the address of the extended register to be accessed. This value is written to the **EPHYADDR** register.
6. Initiate write by writing the **EMACMIADDR** register fields:
 - **PLA**: Physical Layer Address of the PHY. The integrated PHY's address is 0x0.
 - **MII**: Address of the PHY register to be written. In this case, it should be the address of the **EPHYADDR** register, 0xE.
 - **CR**: Clock Reference for the MDIO interface.
 - **MIIW**: Write Initiation. This bit is set to 1 to indicate that a write operation is to be executed.
 - **MII B**: MII Busy. This bit is set to 1 to indicate that the MII is now busy with a write operation. The EMAC clears this bit when the write has been transmitted.
7. Check the **MII B** bit in the **EMACMIADDR** register to identify if the MII interface is busy. When the **MII B** bit is 0, the MII interface is available to write to the PHY registers.
8. The **EMACMIIDATA** register should be written with the value to be passed into the **EPHYREGCTL** register. The **DEVAD** field of the **EPHYREGCTL** register identifies the device address, which is 0x1F, for the integrated PHY. The **FUNC** field of the **EPHYREGCTL** register should be set to 0x1 to indicate a write to an extended register address with no increment.
9. Initiate write by writing the **EMACMIADDR** register fields:
 - **PLA**: Physical Layer Address of the PHY. The integrated PHY's address is 0x0.
 - **MII**: Address of the PHY register to be written. In this case, it should be the address of the **EPHYADDR** register, 0xD.
 - **CR**: Clock Reference for the MDIO interface.
 - **MIIW**: Write Initiation. This bit is set to 1 to indicate that a write operation is to be executed.
 - **MII B**: MII Busy. This bit is set to 1 to indicate that the MII is now busy with a write operation. The EMAC clears this bit when the write has been transmitted.
10. Check the **MII B** bit in the **EMACMIADDR** register to identify if the MII interface is busy. When the **MII B** bit is 0, the MII interface is available to write to the PHY registers.
11. The **EMACMIIDATA** register should be programmed with the data to be written to the **EPHYADDR** register which is transferred to the previously selected extended PHY register.
12. Initiate write by writing the **EMACMIADDR** register fields:
 - **PLA**: Physical Layer Address of the PHY. The integrated PHY's address is 0x0.
 - **MII**: Address of the PHY register to be written. In this case, it should be the address of the **EPHYADDR** register, 0xD.
 - **CR**: Clock Reference for the MDIO interface.
 - **MIIW**: Write Initiation. This bit is set to 1 to indicate that a write operation is to be executed.

- **MIIB**: MII Busy. This bit is set to 1 to indicate that the MII is now busy with a write operation. The EMAC clears this bit when the write has been transmitted.

Read from PHY Registers

The following describes the steps to read from an extended PHY register.

1. Check the **MIIB** bit in the **EMACMIADDR** register to identify if the MII interface is busy. When the **MIIB** bit is 0, the MII interface is available to read to the PHY registers.
2. Initiate the read by writing the **EMACMIADDR** register fields:
 - **PLA**: Physical Layer Address of the PHY. The integrated PHY's address is 0x0.
 - **MII**: Register address of PHY register to be written.
 - **CR**: Clock Reference for the MDIO interface.
 - **MIIW**: Write/Read Initiation. This bit is programmed to a 0 to indicate that a read operation is to be executed.
 - **MIIB**: MII Busy. This bit is set to 1 to indicate that the MII is now busy with a read operation. The EMAC clears this bit when the write has been transmitted.
3. Wait for the MII interface to complete the read by polling the **MIIB** bit.
4. When the **MIIB** is clear, read the contents of the **EMACMIIDATA** register.

Read from Extended PHY Registers

The following describes the steps to read from an extended PHY register.

1. Check the **MIIB** bit in the **EMACMIADDR** register to identify if the MII interface is busy. When the **MIIB** bit is 0, the MII interface is available to read to the PHY registers.
2. Initiate the read by writing the **EMACMIADDR** register fields:
 - **PLA**: Physical Layer Address of the PHY. The integrated PHY's address is 0x0.
 - **MII**: Register address of PHY register to be written.
 - **CR**: Clock Reference for the MDIO interface.
 - **MIIW**: Write/Read Initiation. This bit is programmed to a 0 to indicate that a read operation is to be executed.
 - **MIIB**: MII Busy. This bit is set to 1 to indicate that the MII is now busy with a read operation. The EMAC clears this bit when the write has been transmitted.
3. Wait for the write to complete by polling the **MIIB** bit.
4. When the **MIIB** is clear, read the contents of the **EMACMIIDATA** register.

23.4.3 Interface Configuration

Figure 23-13 on page 1588 shows the proper method for interfacing the Ethernet Controller to a 10/100BASE-T Ethernet jack.

Figure 23-13. Interface to Ethernet Jack

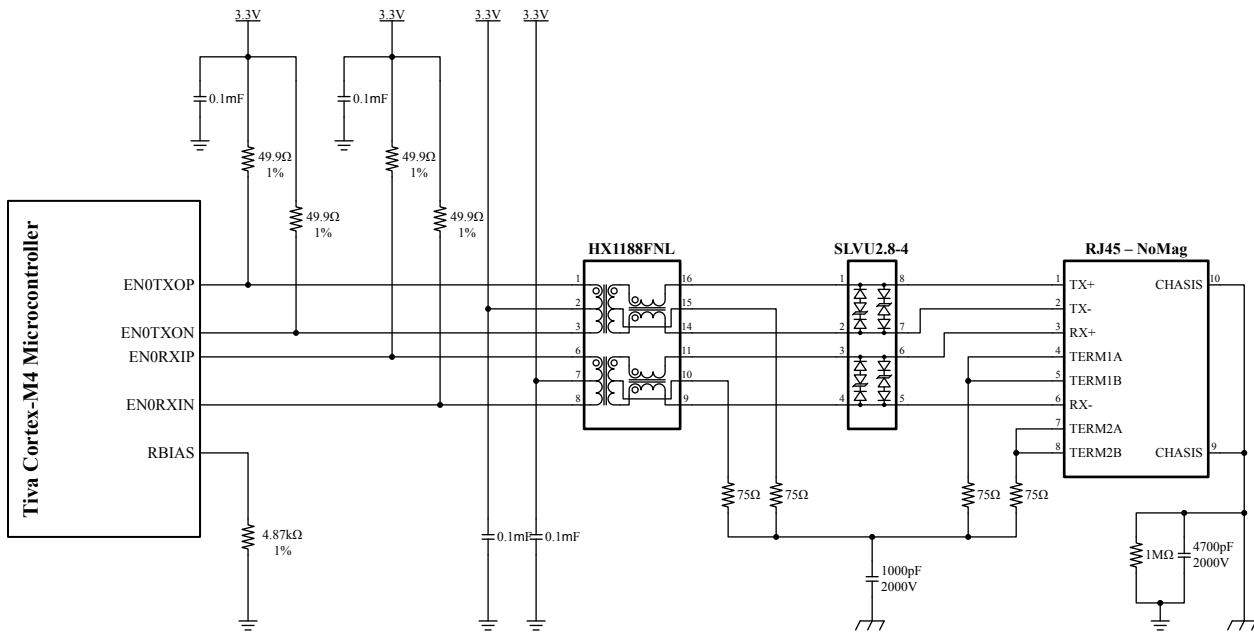

NOTE: The 0.1mF capacitors on pins 2 and 7 of the HX1188FNL should be located near the physical pins of the transformer.

The Ethernet PHY is designed to work with transformers that meet the IEEE 802.3 standard. To utilize the Auto-MDIX (AMDIX) capability of the Ethernet PHY, a symmetrical transformer is recommended. The Pulse HX1188 transformer has been tested and is known to successfully interface to the Ethernet PHY.

Note: If the PHY is not to be used, then the EN0RXIN/EN0TXON EN0RXIP/EN0TXOP pair should be left unconnected and the RBIAS pin should be unconnected as well.

Note: When entering hibernation in VDD3ON mode, the supply rails to the Ethernet resistors R1, R2, R3, R4 found in Figure 23-13 on page 1588 must be switched off.

23.5 Initialization and Configuration

The MAC module and registers are enabled and powered at reset. When reset has completed, the application should enable the clock to the Ethernet MAC by setting the R0 bit in the **Ethernet Controller Run Mode Clock Gating Control (RCGCEMAC)** register at System Control Module offset 0x69C. When the **PREMAC** register, at System Control offset 0xA9C reads as 0x0000.0001, the EMAC registers are ready to be accessed.

The Initialization for the DMA for the Ethernet MAC is as follows:

1. Write to the Ethernet **MAC DMA Bus Mode (EMACDMABUSMOD)** register to set Host bus parameters.
2. Write to the Ethernet **MAC DMA Interrupt Mask Register (EMACDMAIM)** register to mask unnecessary interrupt causes.
3. Create the transmit and receive descriptor lists and then write to the **Ethernet MAC Receive Descriptor List Address (EMACRXDLADDR)** register and the **Ethernet MAC Transmit**

Descriptor List Address (EMACTXDLADDR) register providing the DMA with the starting address of each list.

4. Write to the **Ethernet MAC Frame Filter (EMACFRAMEFLTR)** register, the **Ethernet MAC Hash Table High (EMACHASHTBLH)** and the **Ethernet MAC Hash Table Low (EMACHASHTBLL)** for desired filtering options.
5. Write to the **Ethernet MAC Configuration Register (EMACCFG)** to configure the operating mode and enable the transmit operation.
6. Program Bit 15 (PS) and Bit 11 (DM) of the **EMACCFG** register based on the line status received or read from the PHY status register after auto-negotiation.
7. Write to the **Ethernet MAC DMA Operation Mode (EMACDMAOPMODE)** register to set Bits 13 and 1 to start transmission and reception.
8. Write to the **EMACCFG** register to enable the receive operation.

The Transmit and Receive engines enter the Running state and attempt to acquire descriptors from the respective descriptor lists. The Receive and Transmit engines then begin processing Receive and Transmit operations. The Transmit and Receive processes are independent of each other and can be started or stopped separately.

23.5.1 Ethernet PHY Initialization

After reset, when the EMAC is powered and enabled, the **EMACPC** register default reset value may be sampled and used to configure the PHY. The results of this configuration can also be read in the following EPHY registers:

- **EPHYBMCR** register (MR0)
- **EPHYCFG1** register (MR9)
- **EPHYCFG2** register (MR10)
- **EPHYCFG3** register (MR11)
- **EPHYCTL** register (MR25)

The mappings of the **EMACPC** register bits to the PHY register and bits are as follows:

Table 23-22. EMACPC to PHY Register Mapping

EMACPC Register Bit	Corresponding PHY Register	Corresponding PHY Bit (Bit No.)
PHYEXT	N/A	N/A
DIGRESTART	N/A	N/A
NIBDETDIS	EPHYCFG2	ODDNDIS (1)
RXERIDLE	EPHYCFG2	RXERRIDLE (2)
ISOMILL	EPHYCFG2	ISOMILL (3)
LRR	EPHYCFG1	LLR (7)
TDRRUN	EPHYCFG1	TDRAR (8)
FASTLDMODE	EPHYCFG3	FLDWNM (4:0)
POLSWAP	EPHYCFG3	POLSWAP (7)
MDISWAP	EPHYCFG3	MDIMDIXS (6)

Table 23-22. EMACPC to PHY Register Mapping (continued)

EMACPC Register Bit	Corresponding PHY Register	Corresponding PHY Bit (Bit No.)
RBSTMDIX	EPHYCFG1	RAMDIX (5)
FASTMDIX	EPHYCFG1	FAMDIX (6)
MDIXEN	EPHYCTL	AUTOMDI (15)
FASTRXDV	EPHYCFG1	FRXDVDET (1)
FASTLUPD	EPHYCFG2	FLUPPD (6)
EXTFD	EPHYCFG2	EXTFD (5)
FASTANEN	EPHYCFG1	FASTANEN (4)
FASTANSEL	EPHYCFG1	FANSEL (3:2)
ANEN	EPHYBMCR	ANEN
ANMODE	N/A	N/A
PHYHOLD	N/A	N/A

The MAC module and registers are enabled and powered at reset. When reset has completed and the clock to the Ethernet MAC is enabled by setting the R_0 bit in the **Ethernet Controller Run Mode Clock Gating Control (RCGCEMAC)** register at System Control Module offset 0x69C, the application has the option to enable the PHY with its default interface configuration (as defined by the **Ethernet MAC Peripheral Configuration Register (EMACPC)** register) or with a custom configuration.

23.5.1.1 Default Configuration

To enable the Ethernet PHY with its default configuration, the steps are as follows:

1. To hold the Ethernet PHY from transmitting energy on the line during configuration, set the $PHYHOLD$ bit to 1 in the **EMACPC** register.
2. Enable the clock to the PHY module by writing 0x0000.0001 to the **Ethernet PHY Run Mode Clock Gating Control (RCGCEPHY)** register at offset 0x630. When the R_0 bit reads as 1 in the **PREPHY** register at System Control offset 0xA30, continue initialization.
3. Enable power to the Ethernet PHY by setting the P_0 bit in the **PCEPHY** register at System Control offset 0x930. When the R_0 bit reads as 1 in the **PREPHY** register at System Control offset 0xA30, the PHY registers are ready for programming.

23.5.1.2 Custom Configuration

If a custom configuration of the Ethernet PHY is required, the application can program the configuration registers after reset. The steps for custom configuration are as follows:

1. To hold the PHY from transmitting energy on the line during configuration, set the $PHYHOLD$ bit to 1 in the **EMACPC** register.
2. Enable the clock to the PHY module by writing 0x0000.0001 to the **Ethernet PHY Run Mode Clock Gating Control (RCGCEPHY)** register at offset 0x630. When the R_0 bit reads as 1 in the **PREPHY** register at System Control offset 0xA30, continue initialization.
3. Enable power to the Ethernet PHY by setting the P_0 bit in the **PCEPHY** register at System Control offset 0x930. When the R_0 bit reads as 1 in the **PREPHY** register at System Control offset 0xA30, the PHY registers are ready for programming.

4. Once the **Ethernet PHY Peripheral Ready (PREPHY)** register reads 0x0000.0001, software can write the **EMACPC** register with the required value.
5. After software configuration is complete, the application must set the `DONE` bit in the **Ethernet PHY Configuration 1 (EPHYCFG1)** register at offset 0x009.

Note: If a software reset is asserted to the PHY afterwards through the **SREPHY** register, the custom configuration is lost and the steps described above must be repeated.

23.6 Register Map

Table 23-23 on page 1591 lists the Ethernet Controller MAC and PHY registers. For the MAC registers, the offset listed is a hexadecimal increment to the MAC base address of 0x400E.C000. PHY registers are accessed through the **EMACMIIADDR** register thus the base address is n/a (not applicable) and noted as such above the register descriptions.

The *IEEE 802.3* standard specifies a register set for controlling and gathering status from the PHY layer. The registers are collectively known as the MII Management registers. Table 23-23 on page 1591 also lists these MII Management registers for interfacing to the internal PHY. All addresses given are absolute and are written directly to the `MII` field of the **Ethernet MAC MII Address (EMACMIIADDR)** register, offset 0x010. The `PLA` value of the **EMACMIIADDR** register for the internal PHY is 0x00.

Table 23-23. Ethernet Register Map

Offset	Name	Type	Reset	Description	See page
Ethernet MAC (Ethernet Offset)					
0x000	EMACCFG	RW	0x0000.8000	Ethernet MAC Configuration	1595
0x004	EMACFRAMEFLTR	RW	0x0000.0000	Ethernet MAC Frame Filter	1602
0x008	EMACHASHTBLH	RW	0x0000.0000	Ethernet MAC Hash Table High	1606
0x00C	EMACHASHTBLL	RW	0x0000.0000	Ethernet MAC Hash Table Low	1607
0x010	EMACMIIADDR	RW	0x0000.0000	Ethernet MAC MII Address	1608
0x014	EMACMIIDATA	RW	0x0000.0000	Ethernet MAC MII Data Register	1610
0x018	EMACFLOWCTL	RW	0x0000.0000	Ethernet MAC Flow Control	1611
0x01C	EMACVLANTG	RW	0x0000.0000	Ethernet MAC VLAN Tag	1613
0x024	EMACSTATUS	RO	0x0000.0000	Ethernet MAC Status	1615
0x028	EMACRWUFF	RW	0x0000.0000	Ethernet MAC Remote Wake-Up Frame Filter	1618
0x02C	EMACPMTCTLSTAT	RW	0x0000.0000	Ethernet MAC PMT Control and Status Register	1619
0x038	EMACRIS	RO	0x0000.0000	Ethernet MAC Raw Interrupt Status	1621
0x03C	EMACIM	RW	0x0000.0000	Ethernet MAC Interrupt Mask	1623
0x040	EMACADDR0H	RW	0x8000.FFFF	Ethernet MAC Address 0 High	1624
0x044	EMACADDR0L	RW	0xFFFF.FFFF	Ethernet MAC Address 0 Low Register	1625
0x048	EMACADDR1H	RW	0x0000.FFFF	Ethernet MAC Address 1 High	1626

Table 23-23. Ethernet Register Map (continued)

Offset	Name	Type	Reset	Description	See page
0x04C	EMACADDR1L	RW	0xFFFF.FFFF	Ethernet MAC Address 1 Low	1628
0x050	EMACADDR2H	RW	0x0000.FFFF	Ethernet MAC Address 2 High	1629
0x054	EMACADDR2L	RW	0xFFFF.FFFF	Ethernet MAC Address 2 Low	1631
0x058	EMACADDR3H	RW	0x0000.FFFF	Ethernet MAC Address 3 High	1632
0x05C	EMACADDR3L	RW	0xFFFF.FFFF	Ethernet MAC Address 3 Low	1634
0x0DC	EMACWDOGTO	RW	0x0000.0000	Ethernet MAC Watchdog Timeout	1635
0x100	EMACMMCCTRL	RW	0x0000.0000	Ethernet MAC MMC Control	1636
0x104	EMACMMCRXRIS	RO	0x0000.0000	Ethernet MAC MMC Receive Raw Interrupt Status	1639
0x108	EMACMMCTXRIS	R	0x0000.0000	Ethernet MAC MMC Transmit Raw Interrupt Status	1641
0x10C	EMACMMCRXIM	RW	0x0000.0000	Ethernet MAC MMC Receive Interrupt Mask	1643
0x110	EMACMMCTXIM	RW	0x0000.0000	Ethernet MAC MMC Transmit Interrupt Mask	1645
0x118	EMACTXCNTGB	RO	0x0000.0000	Ethernet MAC Transmit Frame Count for Good and Bad Frames	1647
0x14C	EMACTXCNTSCOL	RO	0x0000.0000	Ethernet MAC Transmit Frame Count for Frames Transmitted after Single Collision	1648
0x150	EMACTXCNTMCOL	RO	0x0000.0000	Ethernet MAC Transmit Frame Count for Frames Transmitted after Multiple Collisions	1649
0x164	EMACTXOCTCNTG	RO	0x0000.0000	Ethernet MAC Transmit Octet Count Good	1650
0x180	EMACRXCNTGB	RO	0x0000.0000	Ethernet MAC Receive Frame Count for Good and Bad Frames	1651
0x194	EMACRXCNTCRCERR	RO	0x0000.0000	Ethernet MAC Receive Frame Count for CRC Error Frames	1652
0x198	EMACRXCNTALGNERR	RO	0x0000.0000	Ethernet MAC Receive Frame Count for Alignment Error Frames	1653
0x1C4	EMACRXCNTGUNI	RO	0x0000.0000	Ethernet MAC Receive Frame Count for Good Unicast Frames	1654
0x584	EMACVLNINCREP	RW	0x0000.0000	Ethernet MAC VLAN Tag Inclusion or Replacement	1655
0x588	EMACVLNHASH	RW	0x0000.0000	Ethernet MAC VLAN Hash Table	1657
0x700	EMACTIMSTCTRL	RW	0x0000.2000	Ethernet MAC Timestamp Control	1658
0x704	EMACSUBSECINC	RW	0x0000.0000	Ethernet MAC Sub-Second Increment	1662
0x708	EMACTIMSEC	RO	0x0000.0000	Ethernet MAC System Time - Seconds	1663
0x70C	EMACTIMNANO	RO	0x0000.0000	Ethernet MAC System Time - Nanoseconds	1664
0x710	EMACTIMSECU	RW	0x0000.0000	Ethernet MAC System Time - Seconds Update	1665
0x714	EMACTIMNANOOU	RW	0x0000.0000	Ethernet MAC System Time - Nanoseconds Update	1666
0x718	EMACTIMADD	RW	0x0000.0000	Ethernet MAC Timestamp Addend	1667

Table 23-23. Ethernet Register Map (continued)

Offset	Name	Type	Reset	Description	See page
0x71C	EMACTARGSEC	RW	0x0000.0000	Ethernet MAC Target Time Seconds	1668
0x720	EMACTARGNANO	RW	0x0000.0000	Ethernet MAC Target Time Nanoseconds	1669
0x724	EMACHWORDSEC	RW	0x0000.0000	Ethernet MAC System Time-Higher Word Seconds	1670
0x728	EMACTIMSTAT	RO	0x0000.0000	Ethernet MAC Timestamp Status	1671
0x72C	EMACPPSCTRL	RW	0x0000.0000	Ethernet MAC PPS Control	1672
0x760	EMACPPS0INTVL	RW	0x0000.0000	Ethernet MAC PPS0 Interval	1675
0x764	EMACPPS0WIDTH	RW	0x0000.0000	Ethernet MAC PPS0 Width	1676
0xC00	EMACDMABUSMOD	RW	0x0002.0101	Ethernet MAC DMA Bus Mode	1677
0xC04	EMACTXPOLL	WO	0x0000.0000	Ethernet MAC Transmit Poll Demand	1681
0xC08	EMACRXPOLLD	WO	0x0000.0000	Ethernet MAC Receive Poll Demand	1682
0xC0C	EMACRXDLADDR	RW	0x0000.0000	Ethernet MAC Receive Descriptor List Address	1683
0xC10	EMACTXDLADDR	RW	0x0000.0000	Ethernet MAC Transmit Descriptor List Address	1684
0xC14	EMACDMARIS	RW	0x0000.0000	Ethernet MAC DMA Interrupt Status	1685
0xC18	EMACDMAOPMODE	RW	0x0000.0000	Ethernet MAC DMA Operation Mode	1691
0xC1C	EMACDMAIM	RW	0x0000.0000	Ethernet MAC DMA Interrupt Mask Register	1696
0xC20	EMACMFBOC	RO	0x0000.0000	Ethernet MAC Missed Frame and Buffer Overflow Counter	1699
0xC24	EMACRXINTWDT	RW	0x0000.0000	Ethernet MAC Receive Interrupt Watchdog Timer	1700
0xC48	EMACHOSTXDESC	R	0x0000.0000	Ethernet MAC Current Host Transmit Descriptor	1701
0xC4C	EMACHOSRXDESC	RO	0x0000.0000	Ethernet MAC Current Host Receive Descriptor	1702
0xC50	EMACHOSTXBA	R	0x0000.0000	Ethernet MAC Current Host Transmit Buffer Address	1703
0xC54	EMACHOSRXBA	R	0x0000.0000	Ethernet MAC Current Host Receive Buffer Address	1704
0xFC0	EMACPP	RO	0x0000.0103	Ethernet MAC Peripheral Property Register	1705
0xFC4	EMACPC	RW	0x0080.040E	Ethernet MAC Peripheral Configuration Register	1706
0xFC8	EMACCC	RO	0x0000.0000	Ethernet MAC Clock Configuration Register	1710
0xFD0	EPHYRIS	RO	0x0000.0000	Ethernet PHY Raw Interrupt Status	1711
0xFD4	EPHYIM	RW	0x0000.0000	Ethernet PHY Interrupt Mask	1712
0xFD8	EPHYMISC	RW1C	0x0000.0000	Ethernet PHY Masked Interrupt Status and Clear	1713
MII Management (Accessed through the EMACMIIADDR Register)					
-	EPHYBMCR	RW	0x3100	Ethernet PHY Basic Mode Control - MR0	1714
-	EPHYBMSR	RO	0x7849	Ethernet PHY Basic Mode Status - MR1	1716
-	EPHYID1	R	0x2000	Ethernet PHY Identifier Register 1 - MR2	1719

Table 23-23. Ethernet Register Map (continued)

Offset	Name	Type	Reset	Description	See page
-	EPHYID2	R	0xA221	Ethernet PHY Identifier Register 2 - MR3	1720
-	EPHYANA	RW	0x01E1	Ethernet PHY Auto-Negotiation Advertisement - MR4	1721
-	EPHYANLPA	RO	0x0000	Ethernet PHY Auto-Negotiation Link Partner Ability - MR5	1723
-	EPHYANER	RO	0x0004	Ethernet PHY Auto-Negotiation Expansion - MR6	1725
-	EPHYANNPTR	RW	0x2001	Ethernet PHY Auto-Negotiation Next Page TX - MR7	1726
-	EPHYANLNPTR	RO	0x0000	Ethernet PHY Auto-Negotiation Link Partner Ability Next Page - MR8	1728
-	EPHYCFG1	RW	0x0000	Ethernet PHY Configuration 1 - MR9	1730
-	EPHYCFG2	RW	0x0004	Ethernet PHY Configuration 2 - MR10	1733
-	EPHYCFG3	RW	0x0000	Ethernet PHY Configuration 3 - MR11	1735
-	EPHYREGCTL	WO	0x0000	Ethernet PHY Register Control - MR13	1737
-	EPHYADDAR	WO	0x0000	Ethernet PHY Address or Data - MR14	1739
-	EPHYSTS	RO	0x0002	Ethernet PHY Status - MR16	1740
-	EPHYSCR	RW	0x0103	Ethernet PHY Specific Control- MR17	1743
-	EPHYMISR1	RW	0x0000	Ethernet PHY MII Interrupt Status 1 - MR18	1746
-	EPHYMISR2	RW	0x0000	Ethernet PHY MII Interrupt Status 2 - MR19	1749
-	EPHYFCSCR	RO	0x0000	Ethernet PHY False Carrier Sense Counter - MR20	1752
-	EPHYRXERCNT	RO	0x0000.0000	Ethernet PHY Receive Error Count - MR21	1753
-	EPHYBISTCR	RW	0x0100	Ethernet PHY BIST Control - MR22	1754
-	EPHYLEDCCR	RW	0x0400	Ethernet PHY LED Control - MR24	1757
-	EPHYCTL	RW	0x8000	Ethernet PHY Control - MR25	1758
-	EPHY10BTSC	RW	0x0000	Ethernet PHY 10Base-T Status/Control - MR26	1760
-	EPHYBICSR1	RW	0x007D	Ethernet PHY BIST Control and Status 1 - MR27	1762
-	EPHYBICSR2	RW	0x05EE	Ethernet PHY BIST Control and Status 2 - MR28	1763
-	EPHYCDCR	RO	0x0102	Ethernet PHY Cable Diagnostic Control - MR30	1764
-	EPHYRCR	RW	0x0000	Ethernet PHY Reset Control - MR31	1765
-	EPHYLED CFG	RW	0x0000.0510	Ethernet PHY LED Configuration - MR37	1766

23.7 Ethernet MAC Register Descriptions

This section lists and describes the MAC registers, in numerical order by address offset. Also see “Ethernet PHY Register Descriptions” on page 1713.

Register 1: Ethernet MAC Configuration (EMACCFG), offset 0x000

The **EMACCFG** register establishes receive and transmit operating modes. Note that the **TWOKPEN** bit is only applicable when the **JFEN** bit is 0.

Ethernet MAC Configuration (EMACCFG)

Base 0x400E.C000

Offset 0x000

Type RW, reset 0x0000.8000

	31	30	29	28	27	26	25	24	23	22	21	20	19	18	17	16
	reserved	SADDR			TWOKPEN	reserved	CST	reserved	WDDIS	JD	reserved	JFEN	IFG		DISCRS	
Type	RO	RW	RW	RW	RW	RO	RW	RO	RW	RW	RO	RW	RW	RW	RW	RW
Reset	0	0	0	0	0	0	0	0	0	0	0	0	0	0	0	0
	15	14	13	12	11	10	9	8	7	6	5	4	3	2	1	0
	PS	FES	DRO	LOOPBM	DUPM	IPC	DR	reserved	ACS	BL		DC	TE	RE	PRELEN	
Type	RO	RW	RW	RW	RW	RW	RW	RO	RW	RW	RW	RW	RW	RW	RW	RW
Reset	1	0	0	0	0	0	0	0	0	0	0	0	0	0	0	0

Bit/Field	Name	Type	Reset	Description														
31	reserved	RO	0x0	Software should not rely on the value of a reserved bit. To provide compatibility with future products, the value of a reserved bit should be preserved across a read-modify-write operation.														
30:28	SADDR	RW	0x0	<p>Source Address Insertion or Replacement Control</p> <p>Bit 30 specifies whether MAC address 0 or 1 registers are used during insertion or replacement for all transmitted frames. Thus for encodings 0x2-0x3, where the most significant bit is 0, the Ethernet MAC Address 0 registers are used.</p> <p>For encodings 0x6-0x7, the Ethernet MAC Address 1 registers are used.</p> <p>Bits [29:28] indicate insertion or replacement. If the value is 0x2 insertion is indicated and if the value is 0x3 replacement is indicated.</p> <table border="1"> <thead> <tr> <th>Value</th> <th>Description</th> </tr> </thead> <tbody> <tr> <td>0x0-0x1</td> <td>reserved</td> </tr> <tr> <td>0x2</td> <td>The Ethernet MAC inserts the content of the Ethernet MAC Address 0 (EMACADDR0x) registers in the SA field of all transmitted frames.</td> </tr> <tr> <td>0x3</td> <td>The Ethernet MAC replaces the content of the Ethernet MAC Address 0 (EMACADDR0x) registers in the SA field of all transmitted frames.</td> </tr> <tr> <td>0x4-0x5</td> <td>reserved</td> </tr> <tr> <td>0x6</td> <td>The MAC inserts the content of the Ethernet MAC Address 1 (EMACADDR1x) registers in the source address (SA) field for all transmitted frames.</td> </tr> <tr> <td>0x7</td> <td>The MAC replaces the content of the Ethernet MAC Address 1 (EMACADDR1x) registers in the source address (SA) field for all transmitted frames.</td> </tr> </tbody> </table> <p>Note: Changes in this field take effect only on the start of a frame. If a write of this field occurs while a frame is being transmitted, only the subsequent frame can use the updated value, and the current frame does not.</p>	Value	Description	0x0-0x1	reserved	0x2	The Ethernet MAC inserts the content of the Ethernet MAC Address 0 (EMACADDR0x) registers in the SA field of all transmitted frames.	0x3	The Ethernet MAC replaces the content of the Ethernet MAC Address 0 (EMACADDR0x) registers in the SA field of all transmitted frames.	0x4-0x5	reserved	0x6	The MAC inserts the content of the Ethernet MAC Address 1 (EMACADDR1x) registers in the source address (SA) field for all transmitted frames.	0x7	The MAC replaces the content of the Ethernet MAC Address 1 (EMACADDR1x) registers in the source address (SA) field for all transmitted frames.
Value	Description																	
0x0-0x1	reserved																	
0x2	The Ethernet MAC inserts the content of the Ethernet MAC Address 0 (EMACADDR0x) registers in the SA field of all transmitted frames.																	
0x3	The Ethernet MAC replaces the content of the Ethernet MAC Address 0 (EMACADDR0x) registers in the SA field of all transmitted frames.																	
0x4-0x5	reserved																	
0x6	The MAC inserts the content of the Ethernet MAC Address 1 (EMACADDR1x) registers in the source address (SA) field for all transmitted frames.																	
0x7	The MAC replaces the content of the Ethernet MAC Address 1 (EMACADDR1x) registers in the source address (SA) field for all transmitted frames.																	

Bit/Field	Name	Type	Reset	Description
27	TWOKPEN	RW	0x0	<p>IEEE 802.3as Support for 2K Packets</p> <p>When set, the MAC considers all frames, up to 2,000 bytes in length, as normal packets. This bit is only valid when the <code>JFEN</code> bit is set to 0. When <code>JFEN</code> is set, configuring <code>TWOKPEN</code> has no effect on Giant Frame status.</p> <p>Value Description</p> <p>0 If the <code>JFEN</code> bit is clear, the MAC considers all received frames larger than 1,518 bytes (1,522 bytes tagged) as Giant Frames.</p> <p>1 Frames up to 2 KB are considered normal packets. If the <code>JFEN</code> bit is clear, the MAC considers all received frames larger than 2K bytes as Giant frames.</p>
26	reserved	RO	0x0	Software should not rely on the value of a reserved bit. To provide compatibility with future products, the value of a reserved bit should be preserved across a read-modify-write operation.
25	CST	RW	0x0	<p>CRC Stripping for Type Frames</p> <p>When set, the last four bytes (Frame Check Sequence FCS) of all frames of Ether type ((Length/Type field greater than or equal to 0x0600) are removed before forwarding the frame to the application.</p> <p>Value Description</p> <p>0 No bytes are removed.</p> <p>1 The last four bytes are removed before forwarding.</p>
24	reserved	RO	0x0	Software should not rely on the value of a reserved bit. To provide compatibility with future products, the value of a reserved bit should be preserved across a read-modify-write operation.
23	WDDIS	RW	0x0	<p>Watchdog Disable</p> <p>When this bit is set, the MAC disables the internal watchdog counter on the receiver. The MAC can receive frames of up to 16,384 bytes. When this bit is cleared, the MAC does not allow more than 2,048 bytes (10,240 if <code>JFEN</code> is set to 1) of the frame being received. The MAC cuts off any bytes received after 2,048 bytes.</p> <p>Value Description</p> <p>0 Watchdog counter enabled.</p> <p>1 Watchdog counter disabled.</p>
22	JD	RW	0x0	<p>Jabber Disable</p> <p>When this bit is set, the MAC disables the jabber counter on the transmitter. The MAC can transfer frames of up to 16,384 bytes. When this bit is clear, the MAC stops transmission if the application sends out more than 2,048 bytes of data (10,240 if <code>JFEN</code> is set to 1).</p> <p>Value Description</p> <p>0 Jabber counter enabled.</p> <p>1 Jabber counter disabled.</p>

Bit/Field	Name	Type	Reset	Description
21	reserved	RO	0x0	Software should not rely on the value of a reserved bit. To provide compatibility with future products, the value of a reserved bit should be preserved across a read-modify-write operation.
20	JFEN	RW	0x0	<p>Jumbo Frame Enable</p> <p>When this bit is set, the MAC allows jumbo frames of 9,018 bytes (9,022 bytes for VLAN tagged frames) without reporting a giant frame error in the receive frame status.</p> <p>Value Description</p> <p>0 Jumbo frames create giant frame error.</p> <p>1 Jumbo frames allowed without error.</p>
19:17	IFG	RW	0x0	<p>Inter-Frame Gap (IFG)</p> <p>These bits control the minimum IFG between frames during transmission.</p> <p>Value Description</p> <p>0x0 96 bit times</p> <p>0x1 88 bit times</p> <p>0x2 80 bit times</p> <p>0x3 72 bit times</p> <p>0x4 64 bit times</p> <p>0x5 56 bit times</p> <p>0x6 48 bit times</p> <p>0x7 40 bit times</p> <p>In half-duplex mode, the minimum IFG can be configured only for 64 bit times (IFG = 0x4). Lower values are not considered.</p>
16	DISCRS	RW	0x0	<p>Disable Carrier Sense During Transmission</p> <p>When this bit is set, the MAC transmit module ignores carrier sense in half-duplex mode. Thus, errors are not generated when there is a loss of carrier or no carrier during transmission. When this bit is clear, the MAC transmitter generates errors because of carrier sense and can even abort the transmissions.</p> <p>Value Description</p> <p>0 Generate errors for carrier sense errors.</p> <p>1 Ignore carrier sense errors.</p>
15	PS	RO	1	<p>Port Select</p> <p>This bit indicates that a 10/100 Mbps interface is supported on this device. This is a read-only bit.</p>
14	FES	RW	0	<p>Speed</p> <p>This bit indicates the speed of the interface.</p> <p>Value Description</p> <p>0 10 Mbps</p> <p>1 100 Mbps</p>

Bit/Field	Name	Type	Reset	Description
13	DRO	RW	0	<p>Disable Receive Own</p> <p>When this bit is set, the MAC disables the reception of frames while transmitting in half-duplex mode.</p> <p>When this bit is clear, the MAC receives all packets that are given by the PHY while transmitting.</p> <p>Value Description</p> <p>0 All packets are received by MAC.</p> <p>1 Disable reception of frames.</p> <p>Note: This bit is not applicable if the MAC is operating in full-duplex mode.</p>
12	LOOPBM	RW	0	<p>Loopback Mode</p> <p>When this bit is set, the MAC operates in the loopback mode at the MII. The MII Receive clock input, <i>ENORXCK</i>, is required for the loopback to work properly, because the Transmit clock is not looped-back internally.</p> <p>Value Description</p> <p>0 MAC does not operate in loopback mode.</p> <p>1 MAC operates in loopback mode.</p>
11	DUPM	RW	0	<p>Duplex Mode</p> <p>When this bit is set, the MAC operates in the full-duplex mode where it can transmit and receive simultaneously.</p> <p>Value Description</p> <p>0 MAC does not operate in full-duplex mode.</p> <p>1 MAC operates in full-duplex mode.</p>
10	IPC	RW	0x0	<p>Checksum Offload</p> <p>Value Description</p> <p>0 The checksum offload function in the receiver is disabled and the corresponding PCE and IP HCE status bits in the frame status are always cleared.</p> <p>1 Checksum Offload Enable</p> <p>Setting this bit enables the IPv4 header checksum checking and IPv4 or IPv6 TCP, UDP, or ICMP payload checksum checking.</p>

Bit/Field	Name	Type	Reset	Description
9	DR	RW	0x0	<p>Disable Retry</p> <p>When this bit is set, the MAC attempts only one transmission. When a collision occurs on the MII interface, the MAC ignores the current frame transmission and reports a frame abort with excessive collision error in the transmit frame status.</p> <p>When this bit is cleared, the MAC attempts retries based on the settings of the BL field (Bits [6:5]).</p> <p>Note: This bit is only applicable in half-duplex mode.</p> <p>Value Description</p> <p>0 MAC retries transmissions based on BL bit field.</p> <p>1 Only one transmission is attempted by the MAC.</p>
8	reserved	RO	0x0	Software should not rely on the value of a reserved bit. To provide compatibility with future products, the value of a reserved bit should be preserved across a read-modify-write operation.
7	ACS	RW	0x0	<p>Automatic Pad or CRC Stripping</p> <p>When this bit is set, the MAC strips the Pad or Frame Check Sequence (FCS) field on the incoming frames only if the value of the length field is less than 1,536 bytes. All received frames with length field greater than or equal to 1,536 bytes are passed to the application without stripping the Pad or FCS field.</p> <p>When this bit is cleared, the MAC passes all incoming frames, without modifying them, to the Host.</p> <p>Value Description</p> <p>0 All frames are passed to host unmodified.</p> <p>1 MAC strips FCS field if value of length field is less than 1,536 bytes.</p>
6:5	BL	RW	0x0	<p>Back-Off Limit</p> <p>The Back-Off limit determines the random integer number (r) of slot time delays (512 bit times for 10/100 Mbps) for which the MAC waits before rescheduling a transmission attempt during retries after a collision. The random integer r takes the value in the range $0 \leq r < 2^k$.</p> <p>The value of k is programmed in the encodings below and is dependent on the retransmission attempt number, n. This bit is applicable only in the half-duplex mode.</p> <p>Value Description</p> <p>0x0 $k = \min(n, 10)$, where k is the lowest value when evaluating n or 10.</p> <p>0x1 $k = \min(n, 8)$, where k is the lowest value when evaluating n or 8.</p> <p>0x2 $k = \min(n, 4)$, where k is the lowest value when evaluating n or 4.</p> <p>0x3 $k = \min(n, 1)$, where k is the lowest value when evaluating n or 1.</p>

Bit/Field	Name	Type	Reset	Description
4	DC	RW	0x0	<p>Deferral Check</p> <p>When this bit is set, the deferral check function is enabled in the MAC. When the transmit state machine is deferred for more than 24,288 bit times, the MAC issues a Frame Abort status, and sets the excessive deferral error bit (<i>EXDEFF</i>) in the MAC MMC Transmit Interrupt (EMACMMCTXRIS) Register.</p> <p>If the Jumbo frame mode (<i>JFEN</i>) is enabled, the threshold for deferral is 155,680 bits times. Deferral begins when the transmitter is ready to transmit, but is prevented because of an active carrier sense signal (CRS) on the MII.</p> <p>The defer time is not cumulative. For example, if the transmitter defers for 10,000 bit times because the CRS signal is active and then the CRS signal becomes inactive, the transmitter transmits and collision happens. Because of collision, the transmitter needs to back off and then defer again after back off completion. In such a scenario, the deferral timer is reset to 0 and it is restarted.</p> <p>When this bit is clear, the deferral check function is disabled and the EMAC defers until the CRS signal goes inactive.</p> <p>Note: This bit is only applicable in half-duplex mode.</p> <p>Value Description</p> <p>0 Deferral check function is disabled.</p> <p>1 Deferral check function is enabled.</p>
3	TE	RW	0x0	<p>Transmitter Enable</p> <p>When this bit is set, the transmit state machine of the MAC is enabled for transmission on the MII.</p> <p>When this bit is clear, the MAC transmit state machine is disabled after the completion of the transmission of the current frame, and does not transmit any further frames.</p> <p>Value Description</p> <p>0 MAC transmit state machine is disabled.</p> <p>1 MAC transmit state machine is enabled.</p>
2	RE	RW	0x0	<p>Receiver Enable</p> <p>When this bit is set, the receiver state machine of the MAC is enabled for receiving frames from the MII.</p> <p>When this bit is clear, the MAC receive state machine is disabled after completion of the reception of the current frame, and does not receive any further frames from the MII.</p> <p>Value Description</p> <p>0 MAC receive state machine is disabled.</p> <p>1 MAC receive state machine is enabled.</p>

Bit/Field	Name	Type	Reset	Description
1:0	PRELEN	RW	0x0	<p>Preamble Length for Transmit Frames</p> <p>These bits control the number of preamble bytes that are added to the beginning of every Transmit frame. The preamble reduction occurs only when the MAC is operating in the full-duplex mode.</p> <p>Value Description</p> <p>0x0 7 bytes of preamble</p> <p>0x1 5 bytes of preamble</p> <p>0x2 3 bytes of preamble</p> <p>0x3 reserved</p>

Register 2: Ethernet MAC Frame Filter (EMACFRAMEFLTR), offset 0x004

The MAC Frame Filter register contains the filter controls for receiving frames. Some of the controls from this register go to the address check block of the MAC, which performs the first level of address filtering. The second level of filtering is performed on the incoming frame, based on other controls such as Pass Bad Frames and Pass Control Frames.

Ethernet MAC Frame Filter (EMACFRAMEFLTR)

Base 0x400E.C000

Offset 0x004

Type RW, reset 0x0000.0000

	31	30	29	28	27	26	25	24	23	22	21	20	19	18	17	16
	RA	reserved														VTFE
Type	RW	RO	RO	RO	RO	RO	RO	RO	RO	RO	RO	RO	RO	RO	RO	RW
Reset	0	0	0	0	0	0	0	0	0	0	0	0	0	0	0	0
	15	14	13	12	11	10	9	8	7	6	5	4	3	2	1	0
	reserved					HPF	SAF	SAIF	PCF	DBF	PM	DAIF	HMC	HUC	PR	
Type	RO	RO	RO	RO	RO	RW	RW	RW	RW	RW	RW	RW	RW	RW	RW	RW
Reset	0	0	0	0	0	0	0	0	0	0	0	0	0	0	0	0

Bit/Field	Name	Type	Reset	Description				
31	RA	RW	0x0	<p>Receive All</p> <p>When this bit is set, the MAC Receiver module passes all received frames, irrespective of whether they pass the address filter or not, to the application. The result of the SA or DA filtering is updated (pass or fail) in the corresponding bits in the Receive Status Word.</p> <p>When this bit is clear, the Receiver module passes only those frames to the application that pass the SA or DA address filter.</p> <p>Value Description</p> <table border="0"> <tr> <td>0</td> <td>MAC RX module only passes frames that pass the SA or DA address filter.</td> </tr> <tr> <td>1</td> <td>MAC RX module passes all received frames.</td> </tr> </table>	0	MAC RX module only passes frames that pass the SA or DA address filter.	1	MAC RX module passes all received frames.
0	MAC RX module only passes frames that pass the SA or DA address filter.							
1	MAC RX module passes all received frames.							
30:17	reserved	RO	0x0	Software should not rely on the value of a reserved bit. To provide compatibility with future products, the value of a reserved bit should be preserved across a read-modify-write operation.				
16	VTFE	RW	0x0	<p>VLAN Tag Filter Enable</p> <p>Value Description</p> <table border="0"> <tr> <td>0</td> <td>MAC forwards all frames regardless of match status of VLAN Tag.</td> </tr> <tr> <td>1</td> <td>MAC drops VLAN tagged frames that do not match VLAN tag comparison.</td> </tr> </table>	0	MAC forwards all frames regardless of match status of VLAN Tag.	1	MAC drops VLAN tagged frames that do not match VLAN tag comparison.
0	MAC forwards all frames regardless of match status of VLAN Tag.							
1	MAC drops VLAN tagged frames that do not match VLAN tag comparison.							
15:11	reserved	RO	0x0	Software should not rely on the value of a reserved bit. To provide compatibility with future products, the value of a reserved bit should be preserved across a read-modify-write operation.				

Bit/Field	Name	Type	Reset	Description
10	HPF	RW	0	<p>Hash or Perfect Filter</p> <p>When this bit is set, it configures the address filter to pass a frame if it matches either the perfect filtering or the hash filtering as set by the HMC or HUC bits in this register.</p> <p>When this bit is clear and the HUC or HMC bit is set, the frame is passed only if it matches the Hash filter.</p> <p>Value Description</p> <p>0 Address filter passes a frame if it matches perfect filtering or hash filtering.</p> <p>1 Address filter passes a frame only if it matches in the hash filter.</p>
9	SAF	RW	0	<p>Source Address Filter Enable</p> <p>When this bit is set, the MAC compares the SA field of the received frames with the values programmed in the enabled SA registers. If the comparison matches, then the SA match bit of Receive Status Word is set. When SA Match bit is set and the SA filter fails, the MAC drops the frame.</p> <p>When this bit is clear, the MAC forwards the received frame to the application with the updated SA Match bit of the Receive Status Word depending on the SA address comparison.</p> <p>Value Description</p> <p>0 Source address filter disabled.</p> <p>1 Source address filter enabled.</p>
8	SAIF	RW	0	<p>Source Address (SA) Inverse Filtering</p> <p>When this bit is set, the Address Check block operates in inverse filtering mode for the SA address comparison. The frames whose SA matches the SA registers are marked as failing the SA address filter.</p> <p>When this bit is reset, frames whose SA does not match the SA registers are marked as failing the SA Address filter.</p> <p>Value Description</p> <p>0 Frames whose SA does not match the SA registers are marked as failing.</p> <p>1 Frames whose SA matches the SA registers are marked as failing.</p>

Bit/Field	Name	Type	Reset	Description
7:6	PCF	RW	0x0	<p>Pass Control Frames</p> <p>These bits control the forwarding of all control frames (including unicast and multicast PAUSE frames).</p> <p>Value Description</p> <p>0x00 The MAC filters all control frames from reaching application.</p> <p>0x1 MAC forwards all control frames except PAUSE control frames to application even if they fail the address filter.</p> <p>0x2 MAC forwards all control frames to application even if they fail the address Filter.</p> <p>0x3 MAC forwards control frames that pass the address Filter.</p> <p>Note that the following conditions should be true for the PAUSE control frames processing:</p> <ul style="list-style-type: none"> ■ Condition 1: The MAC is in full-duplex mode and flow control is enabled by setting the <code>RFE</code> bit of MAC Flow Control Register (EMACFLOWCTL). ■ Condition 2: The destination address (DA) of the received frame matches the special multicast address or the MAC Address 0 (EMACADDR0x) Register when the <code>UP</code> bit of the (EMACFLOWCTL) is set. ■ Condition 3: The Type field of the received frame is 0x8808 and the <code>OPCODE</code> field is 0x0001. <p>This <code>PCF</code> field should be set to 0x1 only when Condition 1 is true; that is, the MAC is programmed to operate in the full-duplex mode and the <code>RFE</code> bit is enabled. Otherwise, the PAUSE frame filtering may be inconsistent. When Condition 1 is false, the PAUSE frames are considered as generic control frames. Therefore, to pass all control frames (including PAUSE control frames) when the full-duplex mode and flow control is not enabled, you should set the <code>PCF</code> field to 0x2 or 0x3 (as required by the application).</p>
5	DBF	RW	0	<p>Disable Broadcast Frames</p> <p>When this bit is set, the address filtering module (AFM) filters all incoming broadcast frames. In addition, it overrides all other filter settings.</p> <p>Value Description</p> <p>0 Address filtering module passes all received broadcast frames.</p> <p>1 Address filtering module filters all incoming broadcast frames.</p>
4	PM	RW	0	<p>Pass All Multicast</p> <p>When set, this bit indicates that all received frames with a multicast destination address (DA) (first bit in the destination address field is 1) are passed.</p> <p>Value Description</p> <p>0 Filtering of multicast frame depends on <code>HMC</code> bit in this register.</p> <p>1 All received frames with multicast DA are passed.</p>

Bit/Field	Name	Type	Reset	Description
3	DAIF	RW	0	<p>Destination Address (DA) Inverse Filtering</p> <p>When this bit is set, the Address Check block operates in inverse filtering mode for the DA address comparison for both unicast and multicast frames.</p> <p>Value Description</p> <p>0 Normal filtering of frames is performed.</p> <p>1 Inverse filtering mode is enabled for DA.</p>
2	HMC	RW	0	<p>Hash Multicast</p> <p>Value Description</p> <p>0 MAC performs a perfect destination address (DA) filtering for multicast frames. It compares the DA field with the values programmed in DA registers.</p> <p>1 MAC performs destination address filtering of received multicast frames according to the hash table.</p>
1	HUC	RW	0	<p>Hash Unicast</p> <p>Value Description</p> <p>0 MAC performs a perfect destination address filtering for unicast frames. It compares the DA field with the values programmed in DA registers.</p> <p>1 MAC performs destination address filtering of unicast frames according to the hash table.</p>
0	PR	RW	0x0	<p>Promiscuous Mode</p> <p>When this bit is set, the Address Filter module passes all incoming frames regardless of its destination or source address. The SA or DA Filter Fails status bits of the Receive Status Word are always cleared when PR is set.</p> <p>Value Description</p> <p>0 Incoming frames are filtered.</p> <p>1 All incoming frames are passed.</p>

Register 3: Ethernet MAC Hash Table High (EMACHASHTBLH), offset 0x008

The 64-bit Hash table is used for group address filtering. For hash filtering, the contents of the Destination Address (DA) in the incoming frame is passed through the CRC logic, and the upper 6 bits of the CRC register are used to index the contents of the Hash table. The most significant bit determines the register to be used (**Ethernet MAC Hash Table High (EMACHASHTBLH)** or **Ethernet MAC Hash Table Low (MACHASHTBL)**), and the other five bits determine which bit within the register. A hash value of 5b'00000 selects bit 0 of the selected register, and a value of 5b'11111 selects bit 31 of the selected register.

The hash value of the destination address is calculated in the following way:

1. Calculate the 32-bit CRC for the DA (See IEEE 802.3, Section 3.2.8 for the steps to calculate CRC32).
2. Perform bit-wise reversal for the value obtained in Step 1.
3. Take the upper 6 bits from the value obtained in Step 2.

For example, if the DA of the incoming frame is received as 0x1F52419CB6AF, then the internally calculated 6-bit Hash value is 0x2C and Bit 12 of **EMACHASHTBLH** register is checked for filtering. If the DA of the incoming frame is received as 0xA00A98000045, then the calculated 6-bit Hash value is 0x07 and Bit 7 of Hash Table Low register is checked for filtering.

If the corresponding bit value of the register is 0x1, the frame is accepted. Otherwise, it is rejected. If the \overline{PM} (Pass All Multicast) bit is set in the **Ethernet MAC Frame Filter (EMACFRAMEFLTR)** register, then all multicast frames are accepted regardless of the multicast hash values.

Ethernet MAC Hash Table High (EMACHASHTBLH)

Base 0x400E.C000

Offset 0x008

Type RW, reset 0x0000.0000

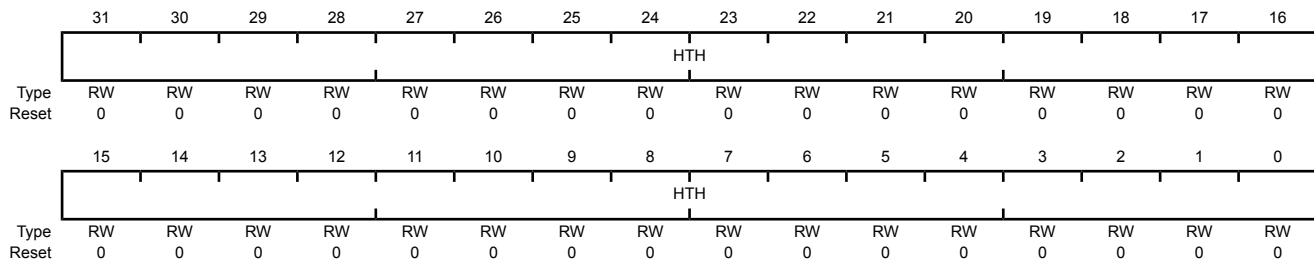

Bit/Field	Name	Type	Reset	Description
31:0	HTH	RW	0x0	Hash Table High This field contains the upper 32 bits of the hash table.

Register 4: Ethernet MAC Hash Table Low (EMACHASHTBLL), offset 0x00C

The **MAC Hash Table Low (EMACHASHTBLL)** register contains the lower 32 bits of the hash table.

Ethernet MAC Hash Table Low (EMACHASHTBLL)

Base 0x400E.C000

Offset 0x00C

Type RW, reset 0x0000.0000

	31	30	29	28	27	26	25	24	23	22	21	20	19	18	17	16
	HTL															
Type	RW	RW	RW	RW	RW	RW	RW	RW	RW	RW	RW	RW	RW	RW	RW	RW
Reset	0	0	0	0	0	0	0	0	0	0	0	0	0	0	0	0
	15	14	13	12	11	10	9	8	7	6	5	4	3	2	1	0
	HTL															
Type	RW	RW	RW	RW	RW	RW	RW	RW	RW	RW	RW	RW	RW	RW	RW	RW
Reset	0	0	0	0	0	0	0	0	0	0	0	0	0	0	0	0

Bit/Field	Name	Type	Reset	Description
31:0	HTL	RW	0x0	Hash Table Low This field contains the lower 32 bits of the hash table.

Register 5: Ethernet MAC MII Address (EMACMIIADDR), offset 0x010

The **Ethernet MAC MII address (EMACMIIADDR)** register controls the management cycles to the PHY through the management interface.

Ethernet MAC MII Address (EMACMIIADDR)

Base 0x400E.C000

Offset 0x010

Type RW, reset 0x0000.0000

	31	30	29	28	27	26	25	24	23	22	21	20	19	18	17	16
	reserved															
Type	RO	RO	RO	RO	RO	RO	RO	RO	RO	RO	RO	RO	RO	RO	RO	RO
Reset	0	0	0	0	0	0	0	0	0	0	0	0	0	0	0	0
	15	14	13	12	11	10	9	8	7	6	5	4	3	2	1	0
	PLA				MII						CR			MIIW	MIIB	
Type	RW	RW	RW	RW	RW	RW	RW	RW	RW	RW	RW	RW	RW	RW	RW	RW
Reset	0	0	0	0	0	0	0	0	0	0	0	0	0	0	0	0

Bit/Field	Name	Type	Reset	Description												
31:16	reserved	RO	0x0	Software should not rely on the value of a reserved bit. To provide compatibility with future products, the value of a reserved bit should be preserved across a read-modify-write operation.												
15:11	PLA	RW	0x0	Physical Layer Address This field gives the PHY address of the MII module. Values 1- 31 (0x1 to 0x1F) are available for external PHY addresses. Note: The integrated PHY's address is 0x00. To access the integrated PHY registers, the PLA bits[15:11] must be zeros.												
10:6	MII	RW	0x0	MII Register These bits select the desired MII registers in the selected PHY device.												
5:2	CR	RW	0x0	Clock Reference Frequency Selection The clock that is sent to the MAC Clock and Status (CSR) registers is the gated System Clock (SYSCLK). The SYSCLK is divided down through the CR field to produce an MDC clock that is approximately between the frequency range 1.0 MHz - 2.5 MHz. The application must program the appropriate CR field based on the System Clock input. <table border="1"> <thead> <tr> <th>Value</th> <th>Description</th> </tr> </thead> <tbody> <tr> <td>0x0</td> <td>The frequency of the System Clock is 60 to 100 MHz providing a MDIO clock of SYSCLK/42.</td> </tr> <tr> <td>0x1</td> <td>The frequency of the System Clock is 100 to 150 MHz providing a MDIO clock of SYSCLK/62.</td> </tr> <tr> <td>0x2</td> <td>The frequency of the System Clock is 20-35 MHz providing a MDIO clock of System Clock/16.</td> </tr> <tr> <td>0x3</td> <td>The frequency of the System Clock is 35 to 60 MHz providing a MDIO clock of System Clock/26.</td> </tr> <tr> <td>0x4-0xF</td> <td>reserved</td> </tr> </tbody> </table>	Value	Description	0x0	The frequency of the System Clock is 60 to 100 MHz providing a MDIO clock of SYSCLK/42.	0x1	The frequency of the System Clock is 100 to 150 MHz providing a MDIO clock of SYSCLK/62.	0x2	The frequency of the System Clock is 20-35 MHz providing a MDIO clock of System Clock/16.	0x3	The frequency of the System Clock is 35 to 60 MHz providing a MDIO clock of System Clock/26.	0x4-0xF	reserved
Value	Description															
0x0	The frequency of the System Clock is 60 to 100 MHz providing a MDIO clock of SYSCLK/42.															
0x1	The frequency of the System Clock is 100 to 150 MHz providing a MDIO clock of SYSCLK/62.															
0x2	The frequency of the System Clock is 20-35 MHz providing a MDIO clock of System Clock/16.															
0x3	The frequency of the System Clock is 35 to 60 MHz providing a MDIO clock of System Clock/26.															
0x4-0xF	reserved															

Bit/Field	Name	Type	Reset	Description
1	MIIW	RW	0x0	<p>MII Write</p> <p>Value Description</p> <p>0 Read operation is active and read data is placed in the MII Data register (EMACMIIDATA).</p> <p>1 PHY is notified that this is a write operation using the MII Data Register (EMACMIIDATA).</p>
0	MIIB	RW	0x0	<p>MII Busy</p> <p>Indicates whether the MII is busy with a read or write access. This bit should read logic 0 before writing to the EMACMIADDR register or the EMACMIIDATA register. During a PHY register access, the software sets this bit to indicate that a read or write access is in progress. The EMACMIIDATA register is invalid until this bit is cleared by the MAC. Therefore, EMACMIIDATA should be kept valid until the MAC clears this bit during a PHY Write operation. Similarly for a read operation, the contents of EMACMIIDATA are not valid until this bit is cleared.</p> <p>Value Description</p> <p>0 EMACMIADDR and EMACMIIDATA are available for reads and writes.</p> <p>1 Read or write access is in progress.</p> <p>The subsequent read or write operations should happen only after the previous operation is complete.</p>

Register 6: Ethernet MAC MII Data Register (EMACMIIDATA), offset 0x014

The **Ethernet MAC MII Data (EMACMIIDATA)** register holds data that is written to and read from the PHY register located at the address specified by the `PLA` and `MII` bit fields of the **Ethernet MAC MII Address (EMACMIIADDR)** register.

Ethernet MAC MII Data Register (EMACMIIDATA)

Base 0x400E.C000

Offset 0x014

Type RW, reset 0x0000.0000

	31	30	29	28	27	26	25	24	23	22	21	20	19	18	17	16
	reserved															
Type	RO	RO	RO	RO	RO	RO	RO	RO	RO	RO	RO	RO	RO	RO	RO	RO
Reset	0	0	0	0	0	0	0	0	0	0	0	0	0	0	0	0
	15	14	13	12	11	10	9	8	7	6	5	4	3	2	1	0
	DATA															
Type	RW	RW	RW	RW	RW	RW	RW	RW	RW	RW	RW	RW	RW	RW	RW	RW
Reset	0	0	0	0	0	0	0	0	0	0	0	0	0	0	0	0

Bit/Field	Name	Type	Reset	Description
31:16	reserved	RO	0x0	Software should not rely on the value of a reserved bit. To provide compatibility with future products, the value of a reserved bit should be preserved across a read-modify-write operation.
15:0	DATA	RW	0x0	MII Data This field contains the 16-bit data value read from the PHY after a management read operation or the 16-bit data value to be written to the PHY before a management write operation.

Register 7: Ethernet MAC Flow Control (EMACFLOWCTL), offset 0x018

The **Ethernet MAC Flow Control (EMACFLOWCTL)** register controls the generation and reception of the control (pause command) frames by the MAC's Flow control module. A write to a register with the **FCBBPA** (bit 0) set to 1 triggers the Flow Control block to generate a pause control frame. The fields of the control frame are selected as specified in the 802.3x specification, and the pause time (**PT**) value from this register is used in the pause time field of the control frame. The **FCBBPA** bit is cleared by the hardware once the control frame is transferred onto the cable. The Host must make sure that the busy bit is clear before writing to the register.

Ethernet MAC Flow Control (EMACFLOWCTL)

Base 0x400E.C000

Offset 0x018

Type RW, reset 0x0000.0000

	31	30	29	28	27	26	25	24	23	22	21	20	19	18	17	16	
	PT																
Type	RW	RW	RW	RW	RW	RW	RW	RW	RW	RW	RW	RW	RW	RW	RW	RW	
Reset	0	0	0	0	0	0	0	0	0	0	0	0	0	0	0	0	
	15	14	13	12	11	10	9	8	7	6	5	4	3	2	1	0	
	reserved								DZQP	reserved				UP	RFE	TFE	FCBBPA
Type	RO	RO	RO	RO	RO	RO	RO	RO	RW	RO	RO	RO	RW	RW	RW	RW	
Reset	0	0	0	0	0	0	0	0	0	0	0	0	0	0	0	0	

Bit/Field	Name	Type	Reset	Description						
31:16	PT	RW	0x0	<p>Pause Time</p> <p>This field holds the value to be used in the pause time field in the transmit control frame.</p> <p>For example, if these bits are set to 0x0100 then 256 slot times are used in the Pause Time field in the transmit control frame.</p>						
15:8	reserved	RO	0x0	<p>Software should not rely on the value of a reserved bit. To provide compatibility with future products, the value of a reserved bit should be preserved across a read-modify-write operation.</p>						
7	DZQP	RW	0	<p>Disable Zero-Quanta Pause</p> <p>When this bit is set, it disables the automatic generation of the Zero-Quanta Pause Control frames on the deassertion of the flow-control signal from the FIFO layer. When this bit is reset, normal operation with automatic Zero-Quanta Pause Control frame generation is enabled.</p> <table border="0"> <tr> <td>Value</td> <td>Description</td> </tr> <tr> <td>0</td> <td>Automatic Zero-Quanta Pause Control generation is enabled.</td> </tr> <tr> <td>1</td> <td>Automatic Zero-Quanta Pause Control generation is disabled.</td> </tr> </table>	Value	Description	0	Automatic Zero-Quanta Pause Control generation is enabled.	1	Automatic Zero-Quanta Pause Control generation is disabled.
Value	Description									
0	Automatic Zero-Quanta Pause Control generation is enabled.									
1	Automatic Zero-Quanta Pause Control generation is disabled.									
6:4	reserved	RO	0x0	<p>Software should not rely on the value of a reserved bit. To provide compatibility with future products, the value of a reserved bit should be preserved across a read-modify-write operation.</p>						

Bit/Field	Name	Type	Reset	Description
3	UP	RW	0x0	<p>Unicast Pause Frame Detect</p> <p>Value Description</p> <p>0 MAC detects only a Pause frame with the unique multicast address specified in the 802.3x standard.</p> <p>1 The MAC detects the pause frames with the station's unicast address specified in the EMACADDR0H and EMACADDR0L register, in addition to detecting pause frames with the unique multicast address.</p>
2	RFE	RW	0x0	<p>Receive Flow Control Enable</p> <p>Value Description</p> <p>0 The decode function of the pause frame is disabled.</p> <p>1 The MAC decodes the received pause frame and disables its transmitter for a specified (pause) time.</p>
1	TFE	RW	0x0	<p>Transmit Flow Control Enable</p> <p>Value Description</p> <p>0 In full duplex mode, the flow control operation in the MAC is disabled, and the MAC does not transmit any pause frames. In half duplex mode, the back-pressure feature is disabled.</p> <p>1 In the full-duplex mode, the MAC enables the flow control operation to transmit pause frames. In half-duplex mode, the MAC enables the back-pressure operation.</p>
0	FCBBPA	RW	0	<p>Flow Control Busy or Back-pressure Activate</p> <p>In the full-duplex mode, this bit should be read as 0x0 before writing to the Flow Control register. To initiate a Pause control frame, the Application must set this bit to 0x1. During a transfer of the Control Frame, this bit continues to be set to signify that a frame transmission is in progress. After the completion of Pause control frame transmission, the MAC resets this bit to 0x0. The EMACFLOWCTL register should not be written to until this bit is cleared.</p> <p>Value Description</p> <p>0 No effect</p> <p>1 In the full-duplex mode, a pause control frame is enabled. In half-duplex mode, a back-pressure function is enabled if the TFE bit is set.</p>

Register 8: Ethernet MAC VLAN Tag (EMACVLANTG), offset 0x01C

The **Ethernet MAC VLAN Tag (MACVLANTG)** register contains the IEEE 802.1Q VLAN Tag to identify the VLAN frames. The MAC compares the 13th and 14th bytes of the receiving frame (Length/Type) with the value 0x8100, and the following two bytes are compared with the VLAN tag. If a match occurs, the MAC sets the received VLAN bit in the receive frame status. The legal length of the frame is increased from 1,518 bytes to 1,522 bytes.

Ethernet MAC VLAN Tag (EMACVLANTG)

Base 0x400E.C000

Offset 0x01C

Type RW, reset 0x0000.0000

	31	30	29	28	27	26	25	24	23	22	21	20	19	18	17	16
	reserved												VTHM	ESVL	VTIM	ETV
Type	RO	RO	RO	RO	RO	RO	RO	RO	RO	RO	RO	RO	RW	RW	RW	RW
Reset	0	0	0	0	0	0	0	0	0	0	0	0	0	0	0	0
	15	14	13	12	11	10	9	8	7	6	5	4	3	2	1	0
	VL															
Type	RW	RW	RW	RW	RW	RW	RW	RW	RW	RW	RW	RW	RW	RW	RW	RW
Reset	0	0	0	0	0	0	0	0	0	0	0	0	0	0	0	0

Bit/Field	Name	Type	Reset	Description
31:20	reserved	RO	0	Software should not rely on the value of a reserved bit. To provide compatibility with future products, the value of a reserved bit should be preserved across a read-modify-write operation.

19	VTHM	RW	0	VLAN Tag Hash Table Match Enable
----	------	----	---	----------------------------------

Value Description

0	The VLAN Hash Match operation is not performed.
1	The most significant four bits of the VLAN tag's CRC are used to index the content of the MAC VLAN Hash Table (EMACVLANTHASH) register. A value of 1 in the EMACVLANTHASH register, corresponding to the index, indicates that the frame matched the VLAN hash table. When Bit 16 (ETV) is set, the CRC of the 12-bit VLAN Identifier (VID) is used for comparison whereas when ETV is reset, the CRC of the 16-bit VLAN tag is used for comparison.

18	ESVL	RW	0	Enable S-VLAN
----	------	----	---	---------------

Value Description

0	The MAC transmitter does not recognize S-VLAN frames as valid VLAN tagged frames.
1	The MAC transmitter and receiver considers the S-VLAN (Type = 0x88A8) frames as valid VLAN tagged frames.

Bit/Field	Name	Type	Reset	Description
17	VTIM	RW	0	<p>VLAN Tag Inverse Match Enable</p> <p>Value Description</p> <p>0 VLAN perfect matching is enabled. The frames with matched VLAN tag are marked as matched.</p> <p>1 VLAN tag inverse matching is enabled. The frames that do not have matching VLAN tag are marked as matched.</p>
16	ETV	RW	0	<p>Enable 12-Bit VLAN Tag Comparison</p> <p>Value Description</p> <p>0 All 16 bits of the 15th and 16th bytes of the received VLAN frame are used for comparison and VLAN hash filtering.</p> <p>1 A 12-bit VLAN identifier is used for comparing and filtering instead of the complete 16-bit VLAN tag.</p> <p>Bits [11:0] of VLAN tag are compared with the corresponding field in the received VLAN-tagged frame. Similarly, when enabled, only 12 bits of the VLAN tag in the received frame are used for hash-based VLAN filtering.</p>
15:0	VL	RW	0x0000	<p>VLAN Tag Identifier for Receive Frames</p> <p>This field contains the 802.1Q VLAN tag to identify the VLAN frames and is compared to the 15th and 16th bytes of the frames being received for VLAN frames. The following list describes the bits of this field:</p> <ul style="list-style-type: none"> ■ Bits [15:13]: User Priority ■ Bit 12: Canonical Format Indicator (CFI) or Drop Eligible Indicator (DEI) ■ Bits[11:0]: VLAN tag's VLAN Identifier (VID) field <p>When the ETV bit is set, only the VID field (Bits[11:0]) is used for comparison. If VL[11:0] is all zeros when the ETV is set, the MAC does not check the fifteenth and 16th bytes for VLAN tag comparison, and declares all frames with a Type field value of 0x8100 or 0x88A8 as VLAN frames.</p>

Register 9: Ethernet MAC Status (EMACSTATUS), offset 0x024

The **Ethernet MAC Status (EMACSTATUS)** register gives the status of all main modules of the transmit and receive data-paths and the FIFOs. An all-zero status indicates that the MAC is in idle state (and FIFOs are empty) and no activity is going on in the data-paths.

Ethernet MAC Status (EMACSTATUS)

Base 0x400E.C000

Offset 0x024

Type RO, reset 0x0000.0000

	31	30	29	28	27	26	25	24	23	22	21	20	19	18	17	16
	reserved						TXFF	TXFE	reserved	TWC	TRC		TXPAUSED	TFC		TPE
Type	RO	RO	RO	RO	RO	RO	RO	RO	RO	RO	RO	RO	RO	RO	RO	RO
Reset	0	0	0	0	0	0	0	0	0	0	0	0	0	0	0	0
	15	14	13	12	11	10	9	8	7	6	5	4	3	2	1	0
	reserved						RXF	reserved	RRC		RWC	reserved	RFCFC		RPE	
Type	RO	RO	RO	RO	RO	RO	RO	RO	RO	RO	RO	RO	RO	RO	RO	RO
Reset	0	0	0	0	0	0	0	0	0	0	0	0	0	0	0	0

Bit/Field	Name	Type	Reset	Description
31:26	reserved	RO	0x00	Software should not rely on the value of a reserved bit. To provide compatibility with future products, the value of a reserved bit should be preserved across a read-modify-write operation.
25	TXFF	RO	0	TX/RX Controller TX FIFO Full Status Value Description 0 The TX/RX Controller TX FIFO is not full. 1 The TX/RX Controller TX FIFO is full. Therefore, the TX/RX Controller cannot accept any more frames for transmission.
24	TXFE	RO	0	TX/RX Controller TX FIFO Not Empty Status Value Description 0 TX/RX Controller TX FIFO is empty. 1 TX/RX Controller TX FIFO is not empty and some data is left for transmission.
23	reserved	RO	0x0	Software should not rely on the value of a reserved bit. To provide compatibility with future products, the value of a reserved bit should be preserved across a read-modify-write operation.
22	TWC	RO	0	TX/RX Controller TX FIFO Write Controller Active Status Value Description 0 TX/RX Controller's TX FIFO write controller is inactive. 1 TX/RX Controller's TX FIFO write controller is active and transferring data to the TX FIFO.

Bit/Field	Name	Type	Reset	Description
21:20	TRC	RO	0x0	<p>TX/RX Controller's TX FIFO Read Controller Status</p> <p>This field indicates the state of the TX FIFO read controller:</p> <p>Value Description</p> <p>0x0 IDLE state</p> <p>0x1 READ state (transferring data to MAC transmitter)</p> <p>0x2 Waiting for TX Status from MAC transmitter</p> <p>0x3 Writing the received TX Status or flushing the TX FIFO</p>
19	TXPAUSED	RO	0	<p>MAC Transmitter PAUSE</p> <p>Value Description</p> <p>0 MAC transmitter is not in PAUSE mode.</p> <p>1 Indicates that the MAC transmitter is in the PAUSE condition (in the full-duplex only mode) and hence does not schedule any frame for transmission.</p>
18:17	TFC	RO	0x0	<p>MAC Transmit Frame Controller Status</p> <p>This field indicates the state of the MAC Transmit Frame Controller module:</p> <p>Value Description</p> <p>0x0 IDLE state</p> <p>0x1 Waiting for status of previous frame or IFG or backoff period to be over</p> <p>0x2 Generating and transmitting a PAUSE control frame (in the full-duplex mode)</p> <p>0x3 Transferring input frame for transmission</p>
16	TPE	RO	0	<p>MAC MII Transmit Protocol Engine Status</p> <p>Value Description</p> <p>0 MAC MII transmit protocol engine is not actively transmitting data.</p> <p>1 MAC MII transmit protocol engine is actively transmitting data and is not in the IDLE state.</p>
15:10	reserved	RO	0x00	<p>Software should not rely on the value of a reserved bit. To provide compatibility with future products, the value of a reserved bit should be preserved across a read-modify-write operation.</p>

Bit/Field	Name	Type	Reset	Description										
9:8	RXF	RO	0x0	<p>TX/RX Controller RX FIFO Fill-level Status</p> <p>This field gives the status of the fill-level of the RX FIFO. The FIFO threshold is programmed by the <code>TCC</code> field in the Ethernet MAC DMA Operation Mode (EMACDMAOPMODE) register.:</p> <table border="1"> <thead> <tr> <th>Value</th> <th>Description</th> </tr> </thead> <tbody> <tr> <td>0x0</td> <td>RX FIFO Empty</td> </tr> <tr> <td>0x1</td> <td>RX FIFO fill level is below the flow-control deactivate threshold</td> </tr> <tr> <td>0x2</td> <td>RX FIFO fill level is above the flow-control activate threshold</td> </tr> <tr> <td>0x3</td> <td>RX FIFO Full</td> </tr> </tbody> </table>	Value	Description	0x0	RX FIFO Empty	0x1	RX FIFO fill level is below the flow-control deactivate threshold	0x2	RX FIFO fill level is above the flow-control activate threshold	0x3	RX FIFO Full
Value	Description													
0x0	RX FIFO Empty													
0x1	RX FIFO fill level is below the flow-control deactivate threshold													
0x2	RX FIFO fill level is above the flow-control activate threshold													
0x3	RX FIFO Full													
7	reserved	RO	0	Software should not rely on the value of a reserved bit. To provide compatibility with future products, the value of a reserved bit should be preserved across a read-modify-write operation.										
6:5	RRC	RO	0x0	<p>TX/RX Controller Read Controller State</p> <p>This field gives the state of the RX FIFO read Controller:</p> <table border="1"> <thead> <tr> <th>Value</th> <th>Description</th> </tr> </thead> <tbody> <tr> <td>0x0</td> <td>IDLE state</td> </tr> <tr> <td>0x1</td> <td>Reading frame data</td> </tr> <tr> <td>0x2</td> <td>Reading frame status (or timestamp)</td> </tr> <tr> <td>0x3</td> <td>Flushing the frame data and status</td> </tr> </tbody> </table>	Value	Description	0x0	IDLE state	0x1	Reading frame data	0x2	Reading frame status (or timestamp)	0x3	Flushing the frame data and status
Value	Description													
0x0	IDLE state													
0x1	Reading frame data													
0x2	Reading frame status (or timestamp)													
0x3	Flushing the frame data and status													
4	RWC	RO	0	<p>TX/RX Controller RX FIFO Write Controller Active Status</p> <table border="1"> <thead> <tr> <th>Value</th> <th>Description</th> </tr> </thead> <tbody> <tr> <td>0</td> <td>The MTL RX FIFO Write Controller is inactive.</td> </tr> <tr> <td>1</td> <td>MTL RX FIFO Write Controller is active and is transferring a received frame to the FIFO.</td> </tr> </tbody> </table>	Value	Description	0	The MTL RX FIFO Write Controller is inactive.	1	MTL RX FIFO Write Controller is active and is transferring a received frame to the FIFO.				
Value	Description													
0	The MTL RX FIFO Write Controller is inactive.													
1	MTL RX FIFO Write Controller is active and is transferring a received frame to the FIFO.													
3	reserved	RO	0	Software should not rely on the value of a reserved bit. To provide compatibility with future products, the value of a reserved bit should be preserved across a read-modify-write operation.										
2:1	RFCFC	RO	0x0	<p>MAC Receive Frame Controller FIFO Status</p> <p>When high, this field indicates the active state of the small FIFO Read and Write controllers of the MAC Receive Frame Controller Module.</p>										
0	RPE	RO	0x0	<p>MAC MII Receive Protocol Engine Status</p> <table border="1"> <thead> <tr> <th>Value</th> <th>Description</th> </tr> </thead> <tbody> <tr> <td>0</td> <td>MAC MII receive protocol engine is not actively receiving data.</td> </tr> <tr> <td>1</td> <td>Indicates that the MAC MII receive protocol engine is actively receiving data and not in IDLE state.</td> </tr> </tbody> </table>	Value	Description	0	MAC MII receive protocol engine is not actively receiving data.	1	Indicates that the MAC MII receive protocol engine is actively receiving data and not in IDLE state.				
Value	Description													
0	MAC MII receive protocol engine is not actively receiving data.													
1	Indicates that the MAC MII receive protocol engine is actively receiving data and not in IDLE state.													

Register 10: Ethernet MAC Remote Wake-Up Frame Filter (EMACRWUFF), offset 0x028

This is the address through which the application writes or reads the remote wake-up frame filter registers. Note that to load values in the **Ethernet MAC Wake-up Frame Filter (EMACRWUFF)** register, the entire register must be written. The **Ethernet MAC Remote Wake-Up Frame Filter (EMACRWUFF)** register is a pointer to eight wake-up frame filter registers. The **Ethernet MAC Remote Wake-Up Frame Filter (EMACRWUFF)** register is loaded by sequentially loading the eight register values. Eight sequential writes to this address programs all of the remote wake-up frame filter registers. Similarly, eight sequential reads from the **EMACRWUFF** register reads all wake-up frame registers.

Ethernet MAC Remote Wake-Up Frame Filter (EMACRWUFF)

Base 0x400E.C000

Offset 0x028

Type RW, reset 0x0000.0000

	31	30	29	28	27	26	25	24	23	22	21	20	19	18	17	16
	WAKEUPFIL															
Type	RW	RW	RW	RW	RW	RW	RW	RW	RW	RW	RW	RW	RW	RW	RW	RW
Reset	0	0	0	0	0	0	0	0	0	0	0	0	0	0	0	0
	15	14	13	12	11	10	9	8	7	6	5	4	3	2	1	0
	WAKEUPFIL															
Type	RW	RW	RW	RW	RW	RW	RW	RW	RW	RW	RW	RW	RW	RW	RW	RW
Reset	0	0	0	0	0	0	0	0	0	0	0	0	0	0	0	0

Bit/Field	Name	Type	Reset	Description
31:0	WAKEUPFIL	RW	0x0	Remote Wake-Up Frame Filter

Register 11: Ethernet MAC PMT Control and Status Register (EMACPMTCTLSTAT), offset 0x02C

The **Ethernet MAC PMT Control and Status (EMACPMTCTLSTAT)** programs and monitors wake-up events.

Ethernet MAC PMT Control and Status Register (EMACPMTCTLSTAT)

Base 0x400E.C000

Offset 0x02C

Type RW, reset 0x0000.0000

	31	30	29	28	27	26	25	24	23	22	21	20	19	18	17	16
	WUPFRRST	reserved				RWKPTR			reserved							
Type	RW	RO	RO	RO	RO	RW	RW	RW	RO	RO	RO	RO	RO	RO	RO	RO
Reset	0	0	0	0	0	0	0	0	0	0	0	0	0	0	0	0
	15	14	13	12	11	10	9	8	7	6	5	4	3	2	1	0
	reserved						GLBLUCAST	reserved		WUPRX	MGKPRX	reserved		WUPFREN	MGKPKTEN	PWRDWN
Type	RO	RO	RO	RO	RO	RO	RW	RO	RO	RO	RO	RO	RO	RW	RW	RW
Reset	0	0	0	0	0	0	0	0	0	0	0	0	0	0	0	0

Bit/Field	Name	Type	Reset	Description
31	WUPFRRST	RW	0	Wake-Up Frame Filter Register Pointer Reset Value Description 0 No effect. 1 Resets the MAC Remote Wake-Up Frame Filter (EMACRWUFF) register pointer to 0x0. It is automatically cleared after one clock cycle.
30:27	reserved	RO	0	Software should not rely on the value of a reserved bit. To provide compatibility with future products, the value of a reserved bit should be preserved across a read-modify-write operation.
26:24	RWKPTR	RW	0	Remote Wake-Up FIFO Pointer This gives the current value (0 to 7) of the MAC Remote Wake-Up Frame Filter (EMACRWUFF) register pointer. The contents of the EMACRWUFF Register are transferred to the receive clock domain when a write occurs to that register when this pointer value equals 7.
23:10	reserved	RO	0	Software should not rely on the value of a reserved bit. To provide compatibility with future products, the value of a reserved bit should be preserved across a read-modify-write operation.
9	GLBLUCAST	RW	0	Global Unicast Value Description 0 No Effect. 1 Enables any unicast packet filtered by the MAC Destination Address Filter (DAF) module's address recognition to be a wake-up frame.
8:7	reserved	RO	0	Software should not rely on the value of a reserved bit. To provide compatibility with future products, the value of a reserved bit should be preserved across a read-modify-write operation.

Bit/Field	Name	Type	Reset	Description
6	WUPRX	RO	0x0	<p>Wake-Up Frame Received</p> <p>Value Description</p> <p>0 No effect.</p> <p>1 The power management event is generated because of the reception of a wake-up frame.</p> <p>This bit is cleared whenever the register is read.</p>
5	MGKPRX	RO	0	<p>Magic Packet Received</p> <p>Value Description</p> <p>0 No effect.</p> <p>1 The power management event is generated because of the reception of a magic packet.</p> <p>This bit is cleared whenever the register is read.</p>
4:3	reserved	RO	0x0	Software should not rely on the value of a reserved bit. To provide compatibility with future products, the value of a reserved bit should be preserved across a read-modify-write operation.
2	WUPFREN	RW	0	<p>Wake-Up Frame Enable</p> <p>Value Description</p> <p>0 Wake-up frame does not affect power management control.</p> <p>1 Generation of a power management event in response to the reception of a wake-up frame is enabled.</p>
1	MGKPKTEN	RW	0	<p>Magic Packet Enable</p> <p>Value Description</p> <p>0 Magic packet reception does not affect power management control.</p> <p>1 Generation of a power management event in response to the reception of a magic packet is enabled.</p>
0	PWRDWN	RW	0	<p>Power Down</p> <p>When set, the MAC receiver drops all received frames until it receives the expected magic packet or wake-up frame. Upon reception, <code>PWRDWN</code> is self-cleared and the power-down mode is disabled. Software can also clear this bit before the expected magic packet or wake-up frame is received. The frames, received by the MAC after this bit is cleared, are forwarded to the application.</p> <p>Value Description</p> <p>0 Frames are forwarded to application.</p> <p>1 MAC receiver drops all received frames until it receives the expected magic packet or wake-up frame.</p>

Register 12: Ethernet MAC Raw Interrupt Status (EMACRIS), offset 0x038

The **Ethernet MAC Raw Interrupt Status (EMACRIS)** register identifies the events in the MAC that can generate interrupt.

Ethernet MAC Raw Interrupt Status (EMACRIS)

Base 0x400E.C000

Offset 0x038

Type RO, reset 0x0000.0000

	31	30	29	28	27	26	25	24	23	22	21	20	19	18	17	16
	reserved															
Type	RO	RO	RO	RO	RO	RO	RO	RO	RO	RO	RO	RO	RO	RO	RO	RO
Reset	0	0	0	0	0	0	0	0	0	0	0	0	0	0	0	0
	15	14	13	12	11	10	9	8	7	6	5	4	3	2	1	0
	reserved						TS	reserved		MMCTX	MMCRX	MMC	PMT	reserved		
Type	RO	RO	RO	RO	RO	RO	RO	RO	RO	RO	RO	RO	RO	RO	RO	RO
Reset	0	0	0	0	0	0	0	0	0	0	0	0	0	0	0	0

Bit/Field	Name	Type	Reset	Description				
31:10	reserved	RO	0x0000.0	Software should not rely on the value of a reserved bit. To provide compatibility with future products, the value of a reserved bit should be preserved across a read-modify-write operation.				
9	TS	RO	0x0	<p>Timestamp Interrupt Status</p> <p>This bit is cleared by reading the <code>TSSOVF</code> bit in the MAC timestamp Status Register (EMACTIMSTAT) register.</p> <p>In this mode, this bit is cleared after the completion of the read of this bit. In all other modes, this bit is reserved.</p> <p>Value Description</p> <table border="0"> <tr> <td>0</td> <td>No timestamp interrupt is present.</td> </tr> <tr> <td>1</td> <td>When the advanced timestamp feature is enabled, this bit indicates one of two conditions is true: <ul style="list-style-type: none"> ■ The system time value equals or exceeds the value specified in the EMAC Target Time Seconds Register (EMACTARGSEC) and MAC Target Time Nanoseconds (EMACTARGNANO) registers. ■ There is an overflow in the EMAC Target Time Seconds (EMACTARGSEC) register. </td> </tr> </table> <p>When default timestamping is enabled, this bit indicates that the system time value is equal to or exceeds the value specified in the EMAC Target Time registers. In this mode, this bit is cleared after the completion of the read of this bit.</p>	0	No timestamp interrupt is present.	1	When the advanced timestamp feature is enabled, this bit indicates one of two conditions is true: <ul style="list-style-type: none"> ■ The system time value equals or exceeds the value specified in the EMAC Target Time Seconds Register (EMACTARGSEC) and MAC Target Time Nanoseconds (EMACTARGNANO) registers. ■ There is an overflow in the EMAC Target Time Seconds (EMACTARGSEC) register.
0	No timestamp interrupt is present.							
1	When the advanced timestamp feature is enabled, this bit indicates one of two conditions is true: <ul style="list-style-type: none"> ■ The system time value equals or exceeds the value specified in the EMAC Target Time Seconds Register (EMACTARGSEC) and MAC Target Time Nanoseconds (EMACTARGNANO) registers. ■ There is an overflow in the EMAC Target Time Seconds (EMACTARGSEC) register. 							
8:7	reserved	RO	0x0	Software should not rely on the value of a reserved bit. To provide compatibility with future products, the value of a reserved bit should be preserved across a read-modify-write operation.				

Bit/Field	Name	Type	Reset	Description
6	MMCTX	RO	0	<p>MMC Transmit Interrupt Status</p> <p>This bit is cleared when all of the bits in the MAC MMC Transmit Interrupt (EMACMMCTXRIS) register are clear.</p> <p>Value Description</p> <p>0 No interrupts exist in the MAC MMC Transmit Interrupt (EMACMMCTXRIS) register.</p> <p>1 Indicates an interrupt has been generated in the MAC MMC Transmit Interrupt (EMACMMCTXRIS) register.</p>
5	MMCRX	RO	0	<p>MMC Receive Interrupt Status</p> <p>This bit is cleared when all of the bits in the Ethernet MAC MMC Receive Interrupt (EMACMMCRXRIS) register are clear.</p> <p>Value Description</p> <p>0 No interrupts exist in the MAC MMC Receive Interrupt (EMACMMCRXRIS) register.</p> <p>1 Indicates an interrupt has been generated in the MAC MMC Receive Interrupt (EMACMMCRXRIS) register.</p>
4	MMC	RO	0x0	<p>MMC Interrupt Status</p> <p>Value Description</p> <p>0 Indicates the MMC-related Interrupt bits [6:5] in this register are clear.</p> <p>1 Indicates that one or more of the MMC-related interrupt bits [6:5] in this register are set.</p>
3	PMT	RO	0x0	<p>PMT Interrupt Status</p> <p>Value Description</p> <p>0 This bit is cleared when both Bits[6:5] are cleared because of a read operation to the MAC PMT Control and Status Register (EMACPMTCTRLSTAT) register.</p> <p>1 Indicates a Magic packet or Wake-on-LAN frame is received in the power-down mode (see Bits 5 and 6 in the MACPMTCTRLSTAT register).</p>
2:0	reserved	RO	0x0	Software should not rely on the value of a reserved bit. To provide compatibility with future products, the value of a reserved bit should be preserved across a read-modify-write operation.

Register 13: Ethernet MAC Interrupt Mask (EMACIM), offset 0x03C

The **Ethernet MAC Interrupt Mask (EMACIM)** Register bits enables the application to mask the interrupt signal caused by the corresponding event in the **Ethernet MAC Raw Interrupt Status (EMACRIS)** Register.

Ethernet MAC Interrupt Mask (EMACIM)

Base 0x400E.C000
Offset 0x03C
Type RW, reset 0x0000.0000

	31	30	29	28	27	26	25	24	23	22	21	20	19	18	17	16
	reserved															
Type	RO	RO	RO	RO	RO	RO	RO	RO	RO	RO	RO	RO	RO	RO	RO	RO
Reset	0	0	0	0	0	0	0	0	0	0	0	0	0	0	0	0
	15	14	13	12	11	10	9	8	7	6	5	4	3	2	1	0
	reserved						TSI	reserved						PMT	reserved	
Type	RO	RO	RO	RO	RO	RO	RW	RO	RO	RO	RO	RO	RW	RO	RO	RO
Reset	0	0	0	0	0	0	0	0	0	0	0	0	0	0	0	0

Bit/Field	Name	Type	Reset	Description
31:10	reserved	RO	0x0000.0	Software should not rely on the value of a reserved bit. To provide compatibility with future products, the value of a reserved bit should be preserved across a read-modify-write operation.
9	TSI	RW	0x0	Timestamp Interrupt Mask Value Description 0 The TSI interrupt status bit in the MAC Raw Interrupt Status (EMACRIS) register is not masked and can cause an interrupt. 1 The assertion of the TIS interrupt status bit in the MAC Raw Interrupt Status (EMACRIS) register is masked and does not cause an interrupt.
8:4	reserved	RO	0x0	Software should not rely on the value of a reserved bit. To provide compatibility with future products, the value of a reserved bit should be preserved across a read-modify-write operation.
3	PMT	RW	0x0	PMT Interrupt Mask Value Description 0 The PMT interrupt status bit in the MAC Raw Interrupt Status (EMACRIS) register is not masked and can cause an interrupt. 1 The assertion of the PMT interrupt status bit in the MAC Raw Interrupt Status (EMACRIS) register is masked and does not cause an interrupt.
2:0	reserved	RO	0	Software should not rely on the value of a reserved bit. To provide compatibility with future products, the value of a reserved bit should be preserved across a read-modify-write operation.

Register 14: Ethernet MAC Address 0 High (EMACADDR0H), offset 0x040

The **Ethernet MAC Address 0 High (EMACADDR0H)** register holds the upper 16 bits of the first 6-byte MAC address of the station. The first (Destination Address) DA byte that is received on the MII interface corresponds to the least significant byte (Bits [7:0]) of the **MAC Address 0 Low Register (EMACADDR0L)** register. For example, if 0x112233445566 is received (0x11 in lane 0 of the first column) on the MII as the destination address, then the **EMAC Address 0 (EMACADDR0x)** register [47:0] is compared with 0x665544332211.

Ethernet MAC Address 0 High (EMACADDR0H)

Base 0x400E.C000

Offset 0x040

Type RW, reset 0x8000.FFFF

	31	30	29	28	27	26	25	24	23	22	21	20	19	18	17	16
	AE	reserved														
Type	RO	RO	RO	RO	RO	RO	RO	RO	RO	RO	RO	RO	RO	RO	RO	RO
Reset	1	0	0	0	0	0	0	0	0	0	0	0	0	0	0	0
	15	14	13	12	11	10	9	8	7	6	5	4	3	2	1	0
	ADDRHI															
Type	RW	RW	RW	RW	RW	RW	RW	RW	RW	RW	RW	RW	RW	RW	RW	RW
Reset	1	1	1	1	1	1	1	1	1	1	1	1	1	1	1	1

Bit/Field	Name	Type	Reset	Description
31	AE	RO	1	Address Enable This register is always valid, so this bit is set always set to 1.
30:16	reserved	RO	0x0	Software should not rely on the value of a reserved bit. To provide compatibility with future products, the value of a reserved bit should be preserved across a read-modify-write operation.
15:0	ADDRHI	RW	0xFFFF	MAC Address0 [47:32] This field contains the upper 16 bits (47:32) of the first 6-byte MAC address. The MAC uses this field for filtering the received frames and inserting the MAC address in the Transmit Flow Control (PAUSE) Frames.

Register 15: Ethernet MAC Address 0 Low Register (EMACADDR0L), offset 0x044

The **MAC Address 0 Low Register (EMACADDR0L)** register holds the lower 32 bits of the first 6-byte MAC address of the station.

Ethernet MAC Address 0 Low Register (EMACADDR0L)

Base 0x400E.C000

Offset 0x044

Type RW, reset 0xFFFFFFFF

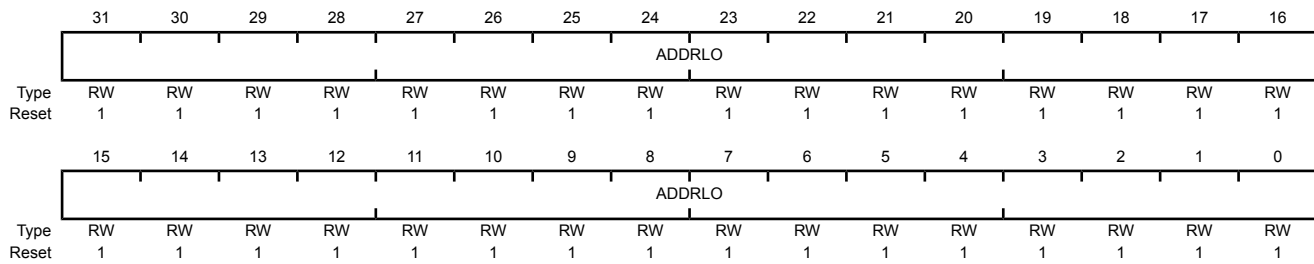

Bit/Field	Name	Type	Reset	Description
31:0	ADDRLO	RW	0xFFFFFFFF	MAC Address0 [31:0] This field contains the lower 32 bits of the first 6-byte MAC address. This is used by the MAC for filtering the received frames and inserting the MAC address in the Transmit Flow Control (PAUSE) Frames.

Register 16: Ethernet MAC Address 1 High (EMACADDR1H), offset 0x048

The **MAC Address 1 High (EMACADDR1H)** register holds the upper 16 bits of the second 6-byte MAC address of the station.

Ethernet MAC Address 1 High (EMACADDR1H)

Base 0x400E.C000

Offset 0x048

Type RW, reset 0x0000.FFFF

	31	30	29	28	27	26	25	24	23	22	21	20	19	18	17	16
	AE	SA	MBC					reserved								
Type	RW	RW	RW	RW	RW	RW	RW	RW	RO	RO	RO	RO	RO	RO	RO	RO
Reset	0	0	0	0	0	0	0	0	0	0	0	0	0	0	0	0
	15	14	13	12	11	10	9	8	7	6	5	4	3	2	1	0
	ADDRHI															
Type	RW	RW	RW	RW	RW	RW	RW	RW	RW	RW	RW	RW	RW	RW	RW	RW
Reset	1	1	1	1	1	1	1	1	1	1	1	1	1	1	1	1

Bit/Field	Name	Type	Reset	Description
31	AE	RW	0	Address Enable Value Description 0 The address filter module ignores the second address for filtering. 1 The address filter module uses the second address for perfect filtering.
30	SA	RW	0	Source Address Value Description 0 When this bit is reset, MAC Address1[47:0] is used to compare with the DA fields of the received frame. 1 When this bit is set, MAC Address1[47:0] is used to compare with the SA fields of the received frame.
29:24	MBC	RW	0x00	Mask Byte Control Mask control bits are provided for comparison of each of the MAC Address bytes. When set high, the MAC does not compare the corresponding byte of received DA or SA with the contents of MAC Address1 registers. Each bit controls the masking of the bytes as follows: <ul style="list-style-type: none"> ■ Bit 29: ADDRHI [15:8] of EMACADDR1H Register ■ Bit 28: ADDRHI [7:0] of EMACADDR1H ■ Bit 27: ADDRLO [31:24] of EMACADDR1L register ■ Bit 26: ADDRLO [23:16] of EMACADDR1L register ■ Bit 25: ADDRLO [15:8] of EMACADDR1L register ■ Bit 24: ADDRLO [7:0] of EMACADDR1L register A group of addresses (known as group address filtering) can be filtered by masking one or more bytes of the address.

Bit/Field	Name	Type	Reset	Description
23:16	reserved	RO	0x0	Software should not rely on the value of a reserved bit. To provide compatibility with future products, the value of a reserved bit should be preserved across a read-modify-write operation.
15:0	ADDRHI	RW	0xFFFF	MAC Address1 [47:32] This field contains the upper 16 bits (47:32) of the second 6-byte MAC address.

Register 17: Ethernet MAC Address 1 Low (EMACADDR1L), offset 0x04C

The **MAC Address 1 Low (EMACADDR1L)** register holds the lower 32 bits of the second 6-byte MAC address of the station.

Ethernet MAC Address 1 Low (EMACADDR1L)

Base 0x400E.C000

Offset 0x04C

Type RW, reset 0xFFFF.FFFF

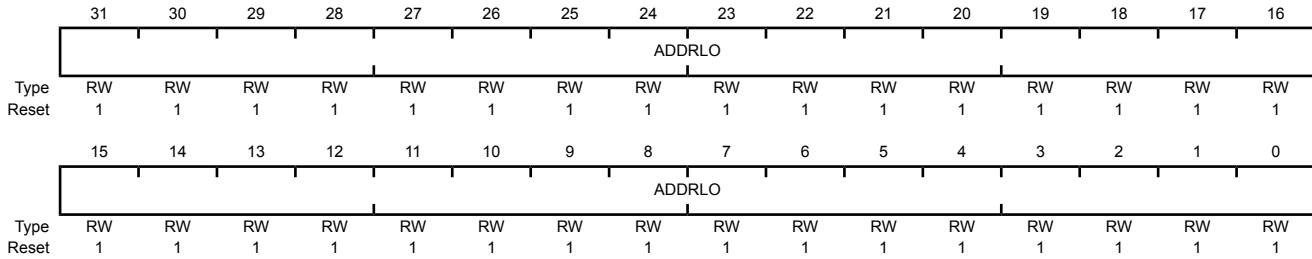

Bit/Field	Name	Type	Reset	Description
31:0	ADDRLO	RW	0xFFFFFFFF	MAC Address1 [31:0] This field contains the lower 32 bits of the second 6-byte MAC address. The content of this field is undefined until loaded by the application after the initialization process.

Register 18: Ethernet MAC Address 2 High (EMACADDR2H), offset 0x050

The **MAC Address 2 High (EMACADDR2H)** register holds the upper 16 bits of the third 6-byte MAC address of the station.

Ethernet MAC Address 2 High (EMACADDR2H)

Base 0x400E.C000

Offset 0x050

Type RW, reset 0x0000.FFFF

	31	30	29	28	27	26	25	24	23	22	21	20	19	18	17	16
	AE	SA	MBC					reserved								
Type	RW	RW	RW	RW	RW	RW	RW	RW	RO	RO	RO	RO	RO	RO	RO	RO
Reset	0	0	0	0	0	0	0	0	0	0	0	0	0	0	0	0
	15	14	13	12	11	10	9	8	7	6	5	4	3	2	1	0
	ADDRHI															
Type	RW	RW	RW	RW	RW	RW	RW	RW	RW	RW	RW	RW	RW	RW	RW	RW
Reset	1	1	1	1	1	1	1	1	1	1	1	1	1	1	1	1

Bit/Field	Name	Type	Reset	Description
31	AE	RW	0x0	Address Enable Value Description 0 The address filter module ignores the third address for filtering. 1 The address filter module uses the third address for perfect filtering.
30	SA	RW	0x0	Source Address Value Description 0 When this bit is reset, the MAC Address2[47:0] is used to compare with the DA fields of the received frame. 1 When this bit is set, the MAC Address2[47:0] is used to compare with the SA fields of the received frame.
29:24	MBC	RW	0x0	Mask Byte Control Mask control bits are provided for comparison of each of the MAC Address bytes. When set high, the MAC does not compare the corresponding byte of received DA or SA with the contents of MAC Address1 registers. Each bit controls the masking of the bytes as follows: <ul style="list-style-type: none"> ■ Bit 29: ADDRHI [15:8] of EMACADDR2H register ■ Bit 28: ADDRHI [7:0] of EMACADDR2H register ■ Bit 27: ADDRLO [31:24] of EMACADDR2L register ■ Bit 26: ADDRLO [23:16] of EMACADDR2L register ■ Bit 25: ADDRLO [15:8] of EMACADDR2L register ■ Bit 24: ADDRLO [7:0] of EMACADDR2L register A group of addresses (known as group address filtering) can be filtered by masking one or more bytes of the address.

Bit/Field	Name	Type	Reset	Description
23:16	reserved	RO	0x0	Software should not rely on the value of a reserved bit. To provide compatibility with future products, the value of a reserved bit should be preserved across a read-modify-write operation.
15:0	ADDRHI	RW	0xFFFF	MAC Address2 [47:32] This field contains the upper 16 bits [47:32] of the third 6-byte MAC address.

Register 19: Ethernet MAC Address 2 Low (EMACADDR2L), offset 0x054

The MAC Address2 Low register holds the lower 32 bits of the third 6-byte MAC address of the station.

Ethernet MAC Address 2 Low (EMACADDR2L)

Base 0x400E.C000

Offset 0x054

Type RW, reset 0xFFFF.FFFF

	31	30	29	28	27	26	25	24	23	22	21	20	19	18	17	16
	ADDRLO															
Type	RW	RW	RW	RW	RW	RW	RW	RW	RW	RW	RW	RW	RW	RW	RW	RW
Reset	1	1	1	1	1	1	1	1	1	1	1	1	1	1	1	1
	15	14	13	12	11	10	9	8	7	6	5	4	3	2	1	0
	ADDRLO															
Type	RW	RW	RW	RW	RW	RW	RW	RW	RW	RW	RW	RW	RW	RW	RW	RW
Reset	1	1	1	1	1	1	1	1	1	1	1	1	1	1	1	1

Bit/Field	Name	Type	Reset	Description
31:0	ADDRLO	RW	0xFFFFFFFF	MAC Address2 [31:0] This field contains the lower 32 bits of the third 6-byte MAC address. The content of this field is undefined until loaded by the Application after the initialization process.

Register 20: Ethernet MAC Address 3 High (EMACADDR3H), offset 0x058

The **Ethernet MAC Address 3 High (EMACADDR3H)** register holds the upper 16 bits of the fourth 6-byte MAC address of the station.

Ethernet MAC Address 3 High (EMACADDR3H)

Base 0x400E.C000

Offset 0x058

Type RW, reset 0x0000.FFFF

	31	30	29	28	27	26	25	24	23	22	21	20	19	18	17	16	
	AE	SA	MBC						reserved								
Type	RW	RW	RW	RW	RW	RW	RW	RW	RO	RO	RO	RO	RO	RO	RO	RO	
Reset	0	0	0	0	0	0	0	0	0	0	0	0	0	0	0	0	
	15	14	13	12	11	10	9	8	7	6	5	4	3	2	1	0	
	ADDRHI																
Type	RW	RW	RW	RW	RW	RW	RW	RW	RW	RW	RW	RW	RW	RW	RW	RW	
Reset	1	1	1	1	1	1	1	1	1	1	1	1	1	1	1	1	

Bit/Field	Name	Type	Reset	Description
31	AE	RW	0x0	Address Enable Value Description 0 The address filter module ignores the third address for filtering. 1 The address filter module uses the third address for perfect filtering.
30	SA	RW	0x0	Source Address Value Description 0 When this bit is reset, the MAC Address3[47:0] is used to compare with the DA fields of the received frame. 1 When this bit is set, the MAC Address3[47:0] is used to compare with the SA fields of the received frame.
29:24	MBC	RW	0x0	Mask Byte Control Mask control bits are provided for comparison of each of the MAC Address bytes. When set high, the MAC does not compare the corresponding byte of received DA or SA with the contents of MAC Address1 registers. Each bit controls the masking of the bytes as follows: <ul style="list-style-type: none"> ■ Bit 29: ADDRHI [15:8] of EMACADDR3H register ■ Bit 28: ADDRHI [7:0] of EMACADDR3H register ■ Bit 27: ADDRLO [31:24] of EMACADDR3L register ■ Bit 26: ADDRLO [23:16] of EMACADDR3L register ■ Bit 25: ADDRLO [15:8] of EMACADDR3L register ■ Bit 24: ADDRLO [7:0] of EMACADDR3L register A group of addresses (known as group address filtering) can be filtered by masking one or more bytes of the address.

Bit/Field	Name	Type	Reset	Description
23:16	reserved	RO	0x0	Software should not rely on the value of a reserved bit. To provide compatibility with future products, the value of a reserved bit should be preserved across a read-modify-write operation.
15:0	ADDRHI	RW	0xFFFF	MAC Address3 [47:32] This field contains the upper 16 bits [47:32] of the fourth 6-byte MAC address.

Register 21: Ethernet MAC Address 3 Low (EMACADDR3L), offset 0x05C

The **Ethernet MAC Address 3 Low (EMACADDR3L)** register holds the lower 32 bits of the fourth 6-byte MAC address of the station.

Ethernet MAC Address 3 Low (EMACADDR3L)

Base 0x400E.C000

Offset 0x05C

Type RW, reset 0xFFFF.FFFF

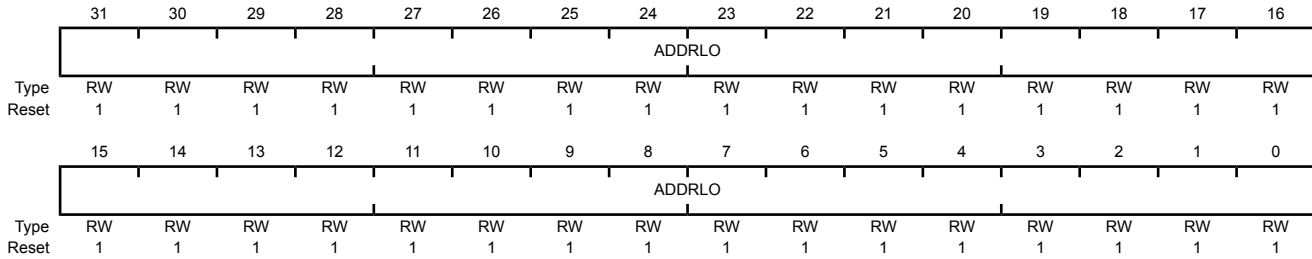

Bit/Field	Name	Type	Reset	Description
31:0	ADDRLO	RW	0xFFFFFFFF	MAC Address3 [31:0] This field contains the lower 32 bits of the fourth 6-byte MAC address. The content of this field is undefined until loaded by the application after the initialization process.

Register 22: Ethernet MAC Watchdog Timeout (EMACWDOGTO), offset 0x0DC

This register controls the watchdog counter for received frames.

Ethernet MAC Watchdog Timeout (EMACWDOGTO)

Base 0x400E.C000

Offset 0x0DC

Type RW, reset 0x0000.0000

	31	30	29	28	27	26	25	24	23	22	21	20	19	18	17	16
	reserved															PWE
Type	RO	RO	RO	RO	RO	RO	RO	RO	RO	RO	RO	RO	RO	RO	RO	RW
Reset	0	0	0	0	0	0	0	0	0	0	0	0	0	0	0	0
	15	14	13	12	11	10	9	8	7	6	5	4	3	2	1	0
	reserved		WTO													
Type	RO	RO	RW	RW	RW	RW	RW	RW	RW	RW	RW	RW	RW	RW	RW	RW
Reset	0	0	0	0	0	0	0	0	0	0	0	0	0	0	0	0

Bit/Field	Name	Type	Reset	Description
31:17	reserved	RO	0	Software should not rely on the value of a reserved bit. To provide compatibility with future products, the value of a reserved bit should be preserved across a read-modify-write operation.
16	PWE	RW	0	Programmable Watchdog Enable
				Value Description
				0 The watchdog timeout for a received frame is controlled by setting the WD and JE bits in the EMACCFG register.
				1 When the WD bit of the EMACCFG register is clear, the WTO field is used as a watchdog timeout for a received frame.
15:14	reserved	RO	0	Software should not rely on the value of a reserved bit. To provide compatibility with future products, the value of a reserved bit should be preserved across a read-modify-write operation.
13:0	WTO	RW	0	Watchdog Timeout When the PWE bit in the EMACWDOGTO register is set and the WD bit of the EMACCFG register is clear, this field is used as a watchdog timeout value for a received frame. If the length of a received frame exceeds the value of this field, such frame is terminated and declared an error frame.
				Note: When the PWE bit is set the value in this field should be more than 1,522 (0x05F2). Otherwise, valid, tagged IEEE 802.3-frames are declared as error frames and are dropped.

Register 23: Ethernet MAC MMC Control (EMACMMCCTRL), offset 0x100

The MMC Control register establishes the operating mode of the management counters.

Note: The `CNTRST` bit has higher priority than the `CNTPRST`. Therefore, when the software tries to set both bits in the same write cycle, all counters are cleared and the `CNTPRST` is not set.

Ethernet MAC MMC Control (EMACMMCCTRL)

Base 0x400E.C000

Offset 0x100

Type RW, reset 0x0000.0000

	31	30	29	28	27	26	25	24	23	22	21	20	19	18	17	16
	reserved															
Type	RO	RO	RO	RO	RO	RO	RO	RO	RO	RO	RO	RO	RO	RO	RO	RO
Reset	0	0	0	0	0	0	0	0	0	0	0	0	0	0	0	0
	15	14	13	12	11	10	9	8	7	6	5	4	3	2	1	0
	reserved							UCDBC	reserved		CNTPRSTLVL	CNTPRST	CNTFREEZ	RSTONRD	CNTSTPRO	CNTRST
Type	RO	RO	RO	RO	RO	RO	RO	RW	RO	RO	RW	RW	RW	RW	RW	RW
Reset	0	0	0	0	0	0	0	0	0	0	0	0	0	0	0	0

Bit/Field	Name	Type	Reset	Description
31:9	reserved	RO	0x00	Software should not rely on the value of a reserved bit. To provide compatibility with future products, the value of a reserved bit should be preserved across a read-modify-write operation.
8	UCDBC	RW	0	Update MMC Counters for Dropped Broadcast Frames Value Description 0 MMC Counters are not updated for dropped broadcast frames. 1 MAC updates all related MMC counters for broadcast frames dropped due to setting of <code>DBF</code> bit (Disable Broadcast Frames) of the MAC Frame Filter(EMACFRAMEFLTR) register.
7:6	reserved	RO	0	Software should not rely on the value of a reserved bit. To provide compatibility with future products, the value of a reserved bit should be preserved across a read-modify-write operation.

Bit/Field	Name	Type	Reset	Description
5	CNTPRSTLVL	RW	0	<p>Full/Half Preset Level Value</p> <p>Value Description</p> <p>0 If CNTPRST is set, all MMC counters get preset to almost-half value. All octet counters get preset to 0x7FFF.F800 (half value - 2 KB) and all frame-counters get preset to 0x7FFF.FFF0 (half value - 16).</p> <p>1 If CNTPRST is set, all MMC counters get preset to almost-full value. All octet counters get preset to 0xFFFF.F800 (full value - 2 KB) and all frame-counters gets preset to 0xFFFF_FFF0 (full value - 16).</p> <p>This bit, along with CNTPRST, is useful for debugging and testing the assertion of interrupts because of MMC counter becoming half-full or full.</p> <p>For 16-bit counters, the almost-half preset values are 0x7800 and 0x7FF0 for the respective octet and frame counters. Similarly, the almost-full preset values for the 16-bit counters are 0xF800 and 0xFFFF0.</p>
4	CNTPRST	RW	0	<p>Counters Preset</p> <p>Value Description</p> <p>0 Normal operation.</p> <p>1 All counters are initialized or preset to almost full or almost half according to the CNTPRSTLVL bit. The CNTPRST bit is cleared automatically after 1 clock cycle.</p> <p>This bit, along with CNTPRSTLVL, is useful for debugging and testing the assertion of interrupts because of MMC counter becoming half-full or full.</p>
3	CNTFREEZ	RW	0	<p>MMC Counter Freeze</p> <p>When this bit is set, it freezes all MMC counters to their current value. Until this bit is reset, no MMC counter is updated because of any transmitted or received frame. If any MMC counter is read with the RSTONRD bit set, then that counter is also cleared in this mode.</p> <p>Value Description</p> <p>0 MMC counters are updated when a frame is transmitted or received.</p> <p>1 When this bit is set, it freezes all MMC counters to their current value. Until this bit is reset to 0, no MMC counter is updated because of any transmitted or received frame.</p>
2	RSTONRD	RW	0x0	<p>Reset on Read</p> <p>Value Description</p> <p>0 No effect.</p> <p>1 MMC counters are reset to zero after a read (self-clearing after reset). The counters are cleared when the least significant byte lane (bits[7:0]) is read.</p>

Bit/Field	Name	Type	Reset	Description
1	CNTSTPRO	RW	0	Counters Stop Rollover Value Description 0 No effect. 1 After reaching maximum value, the MMC counters do not roll over to zero.
0	CNTRST	RW	0x0	Counters Reset Value Description 0 No effect 1 All MMC counters are reset. This bit is cleared automatically after one clock cycle.

Register 24: Ethernet MAC MMC Receive Raw Interrupt Status (EMACMMCRXRIS), offset 0x104

The **MAC MMC Receive Interrupt (EMACMMCRXRIS)** register maintains the interrupts that are generated when the following happens:

- Receive statistic counters reach half of their maximum values (0x8000.0000 for 32-bit counter and 0x8000 for 16-bit counter).
- Receive statistic counters cross their maximum values (0xFFFF.FFFF for 32-bit counter and 0xFFFF for 16-bit counter).

When the Counter Stop Rollover (CNTSTPRO bit) in the **MAC MMC Control (EMACMMCCTRL)** register is set, interrupts are set but the counter remains at all-ones. The **EMACMMCRXRIS** register is a 32-bit wide register. An interrupt bit is cleared when the respective MMC counter that caused the interrupt is read. The least significant byte lane (bits[7:0]) of the respective counter must be read in order to clear the interrupt bit.

Ethernet MAC MMC Receive Raw Interrupt Status (EMACMMCRXRIS)

Base 0x400E.C000

Offset 0x104

Type RO, reset 0x0000.0000

	31	30	29	28	27	26	25	24	23	22	21	20	19	18	17	16
	reserved														UCGF	reserved
Type	RO	RO	RO	RO	RO	RO	RO	RO	RO	RO	RO	RO	RO	RO	RO	RO
Reset	0	0	0	0	0	0	0	0	0	0	0	0	0	0	0	0
	15	14	13	12	11	10	9	8	7	6	5	4	3	2	1	0
	reserved										ALGNERR	CRCERR	reserved			GBF
Type	RO	RO	RO	RO	RO	RO	RO	RO	RO	RO	RO	RO	RO	RO	RO	RO
Reset	0	0	0	0	0	0	0	0	0	0	0	0	0	0	0	0

Bit/Field	Name	Type	Reset	Description
31:18	reserved	RO	0x00	Software should not rely on the value of a reserved bit. To provide compatibility with future products, the value of a reserved bit should be preserved across a read-modify-write operation.
17	UCGF	RO	0x0	MMC Receive Unicast Good Frame Counter Interrupt Status
				Value Description
			0	The receive Ethernet MAC Receive Frame Count for Good Unicast Frames (EMACRXCNTGUNI) register has not reached half of the maximum value or the maximum value.
			1	The receive Ethernet MAC Receive Frame Count for Good Unicast Frames (EMACRXCNTGUNI) register has reached half of the maximum value or the maximum value.
16:7	reserved	RO	0	Software should not rely on the value of a reserved bit. To provide compatibility with future products, the value of a reserved bit should be preserved across a read-modify-write operation.

Bit/Field	Name	Type	Reset	Description
6	ALGNERR	RO	0x0	<p>MMC Receive Alignment Error Frame Counter Interrupt Status</p> <p>Value Description</p> <p>0 The Ethernet MAC Receive Frame Count for Alignment Error Frames (EMACRXCNTALGNERR) register has not reached half of the maximum value or the maximum value.</p> <p>1 The Ethernet MAC Receive Frame Count for Alignment Error Frames (EMACRXCNTALGNERR) register has reached half of the maximum value or the maximum value.</p>
5	CRCERR	RO	0x0	<p>MMC Receive CRC Error Frame Counter Interrupt Status</p> <p>Value Description</p> <p>0 The Ethernet MAC Receive Frame Count for CRC Error Frames (EMACRXCNTCRCERR) register has not reached half of the maximum value or the maximum value.</p> <p>1 The Ethernet MAC Receive Frame Count for CRC Error Frames (EMACRXCNTCRCERR) register has reached half of the maximum value or the maximum value.</p>
4:1	reserved	RO	0	Software should not rely on the value of a reserved bit. To provide compatibility with future products, the value of a reserved bit should be preserved across a read-modify-write operation.
0	GBF	RO	0x0	<p>MMC Receive Good Bad Frame Counter Interrupt Status</p> <p>Value Description</p> <p>0 The Ethernet MAC Receive Frame Count for Good and Bad Frames (EMACRXCNTGB) register has not reached half of the maximum value or the maximum value.</p> <p>1 The Ethernet MAC Receive Frame Count for Good and Bad Frames (EMACRXCNTGB) register has reached half of the maximum value or the maximum value.</p>

Register 25: Ethernet MAC MMC Transmit Raw Interrupt Status (EMACMMCTXRIS), offset 0x108

The **MAC MMC Transmit Interrupt (EMACMMCTXRIS)** register maintains the interrupts generated when transmit statistic counters reach half of their maximum values (0x8000_0000 for 32-bit counter and 0x8000 for 16-bit counter), and the maximum values (0xFFFF_FFFF for 32-bit counter and 0xFFFF for 16-bit counter). When the **CNTSTPRO** bit is set in the **MAC MMC Control (EMACMMCTRL)** register, interrupts are set but the counter remains at all-ones. The **EMACMMCTXRIS** register is a 32-bit wide register. An interrupt bit is cleared when the respective MMC counter that caused the interrupt is read. The least significant byte lane (Bits[7:0]) of the respective counter must be read in order to clear the interrupt bit.

Ethernet MAC MMC Transmit Raw Interrupt Status (EMACMMCTXRIS)

Base 0x400E.C000

Offset 0x108

Type R, reset 0x0000.0000

	31	30	29	28	27	26	25	24	23	22	21	20	19	18	17	16
	reserved											OCTCNT	reserved			
Type	RO	RO	RO	RO	RO	RO	RO	RO	RO	RO	RO	RO	RO	RO	RO	RO
Reset	0	0	0	0	0	0	0	0	0	0	0	0	0	0	0	0
	15	14	13	12	11	10	9	8	7	6	5	4	3	2	1	0
	MCOLLGF	SCOLLGF	reserved											GBF	reserved	
Type	RO	RO	RO	RO	RO	RO	RO	RO	RO	RO	RO	RO	RO	RO	RO	RO
Reset	0	0	0	0	0	0	0	0	0	0	0	0	0	0	0	0

Bit/Field	Name	Type	Reset	Description
31:21	reserved	RO	0x0	Software should not rely on the value of a reserved bit. To provide compatibility with future products, the value of a reserved bit should be preserved across a read-modify-write operation.
20	OCTCNT	RO	0x0	Octet Counter Interrupt Status
				Value Description
			0	The Ethernet MAC Transmit Octet Count Good (EMACTXOCTCNTG) register has not reached half of the maximum value or the maximum value.
			1	The Ethernet MAC Transmit Octet Count Good (EMACTXOCTCNTG) register has reached half of the maximum value or the maximum value.
19:16	reserved	RO	0	Software should not rely on the value of a reserved bit. To provide compatibility with future products, the value of a reserved bit should be preserved across a read-modify-write operation.

Bit/Field	Name	Type	Reset	Description
15	MCOLLGF	RO	0x0	<p>MMC Transmit Multiple Collision Good Frame Counter Interrupt Status</p> <p>Value Description</p> <p>0 The Ethernet MAC Transmit Frame Count for Frames Transmitted after Multiple Collisions (EMACTXCNTMCOL) register has not reached half of the maximum value or the maximum value.</p> <p>1 The Ethernet MAC Transmit Frame Count for Frames Transmitted after Multiple Collisions (EMACTXCNTMCOL) register has reached half of the maximum value or the maximum value.</p>
14	SCOLLGF	RO	0x0	<p>MMC Transmit Single Collision Good Frame Counter Interrupt Status</p> <p>Value Description</p> <p>0 The Ethernet MAC Transmit Frame Count for Frames Transmitted after Single Collision (EMACTXCNTSCOL) register has not reached half of the maximum value or the maximum value.</p> <p>1 The Ethernet MAC Transmit Frame Count for Frames Transmitted after Single Collision (EMACTXCNTSCOL) register has reached half of the maximum value or the maximum value.</p>
13:2	reserved	RO	0	Software should not rely on the value of a reserved bit. To provide compatibility with future products, the value of a reserved bit should be preserved across a read-modify-write operation.
1	GBF	RO	0x0	<p>MMC Transmit Good Bad Frame Counter Interrupt Status</p> <p>Value Description</p> <p>0 The Ethernet MAC Transmit Frame Count for Good and Bad Frames (EMACTXCNTGB) register has not reached half of the maximum value or the maximum value.</p> <p>1 The Ethernet MAC Transmit Frame Count for Good and Bad Frames (EMACTXCNTGB) register has reached half of the maximum value or the maximum value.</p>
0	reserved	RO	0	Software should not rely on the value of a reserved bit. To provide compatibility with future products, the value of a reserved bit should be preserved across a read-modify-write operation.

Register 26: Ethernet MAC MMC Receive Interrupt Mask (EMACMMCRXIM), offset 0x10C

The **MAC MMC Receive Interrupt Mask (EMACMMCRXIM)** register maintains the masks for the interrupts generated when the receive statistic counters reach half of their maximum value, or maximum value. This register is 32-bits wide.

Ethernet MAC MMC Receive Interrupt Mask (EMACMMCRXIM)

Base 0x400E.C000

Offset 0x10C

Type RW, reset 0x0000.0000

	31	30	29	28	27	26	25	24	23	22	21	20	19	18	17	16
	reserved														UCGF	reserved
Type	RO	RO	RO	RO	RO	RO	RO	RO	RO	RO	RO	RO	RO	RO	RW	RO
Reset	0	0	0	0	0	0	0	0	0	0	0	0	0	0	0	0
	15	14	13	12	11	10	9	8	7	6	5	4	3	2	1	0
	reserved										ALGNERR	CRCERR	reserved			GBF
Type	RO	RO	RO	RO	RO	RO	RO	RO	RO	RO	RW	RW	RO	RO	RO	RW
Reset	0	0	0	0	0	0	0	0	0	0	0	0	0	0	0	0

Bit/Field	Name	Type	Reset	Description
31:18	reserved	RO	0x0	Software should not rely on the value of a reserved bit. To provide compatibility with future products, the value of a reserved bit should be preserved across a read-modify-write operation.
17	UCGF	RW	0x0	MMC Receive Unicast Good Frame Counter Interrupt Mask Value Description 0 An interrupt is sent to the interrupt controller when the UCGF bit in the EMACMMCRXRIS register is set. 1 The UCGF interrupt is suppressed and not sent to the interrupt controller.
16:7	reserved	RO	0	Software should not rely on the value of a reserved bit. To provide compatibility with future products, the value of a reserved bit should be preserved across a read-modify-write operation.
6	ALGNERR	RW	0x0	MMC Receive Alignment Error Frame Counter Interrupt Mask Value Description 0 An interrupt is sent to the interrupt controller when the ALGNERR bit in the EMACMMCRXRIS register is set. 1 The ALGNERR interrupt is suppressed and not sent to the interrupt controller.
5	CRCERR	RW	0x0	MMC Receive CRC Error Frame Counter Interrupt Mask Value Description 0 An interrupt is sent to the interrupt controller when the CRCERR bit in the EMACMMCRXRIS register is set. 1 The CRCERR interrupt is suppressed and not sent to the interrupt controller.

Bit/Field	Name	Type	Reset	Description
4:1	reserved	RO	0	Software should not rely on the value of a reserved bit. To provide compatibility with future products, the value of a reserved bit should be preserved across a read-modify-write operation.
0	GBF	RW	0x0	MMC Receive Good Bad Frame Counter Interrupt Mask
				Value Description
				0 An interrupt is sent to the interrupt controller when the GBF bit in the EMACMMCRXRIS register is set.
				1 The GBF interrupt is suppressed and not sent to the interrupt controller.

Register 27: Ethernet MAC MMC Transmit Interrupt Mask (EMACMMCTXIM), offset 0x110

The **MAC MMC Transmit Interrupt Mask (EMACMMCTXIM)** register maintains the masks for the interrupts generated when the transmit statistic counters reach half of their maximum value or maximum value. This register is 32-bits wide.

Ethernet MAC MMC Transmit Interrupt Mask (EMACMMCTXIM)

Base 0x400E.C000

Offset 0x110

Type RW, reset 0x0000.0000

	31	30	29	28	27	26	25	24	23	22	21	20	19	18	17	16
	reserved											OCTCNT	reserved			
Type	RO	RO	RO	RO	RO	RO	RO	RO	RO	RO	RO	RW	RO	RO	RO	RO
Reset	0	0	0	0	0	0	0	0	0	0	0	0	0	0	0	0
	15	14	13	12	11	10	9	8	7	6	5	4	3	2	1	0
	MCOLLGF	SCOLLGF	reserved											GBF	reserved	
Type	RW	RW	RO	RO	RO	RO	RO	RO	RO	RO	RO	RO	RO	RO	RW	RO
Reset	0	0	0	0	0	0	0	0	0	0	0	0	0	0	0	0

Bit/Field	Name	Type	Reset	Description
31:21	reserved	RO	0x0	Software should not rely on the value of a reserved bit. To provide compatibility with future products, the value of a reserved bit should be preserved across a read-modify-write operation.
20	OCTCNT	RW	0x0	MMC Transmit Good Octet Counter Interrupt Mask Value Description 0 An interrupt is sent to the interrupt controller when the OCTCNT bit in the EMACMMCTXRIS register is set. 1 The OCTCNT interrupt is suppressed and not sent to the interrupt controller.
19:16	reserved	RO	0	Software should not rely on the value of a reserved bit. To provide compatibility with future products, the value of a reserved bit should be preserved across a read-modify-write operation.
15	MCOLLGF	RW	0x0	MMC Transmit Multiple Collision Good Frame Counter Interrupt Mask Value Description 0 An interrupt is sent to the interrupt controller when the MCOLLGF bit in the EMACMMCTXRIS register is set. 1 The MCOLLGF interrupt is suppressed and not sent to the interrupt controller.
14	SCOLLGF	RW	0x0	MMC Transmit Single Collision Good Frame Counter Interrupt Mask Value Description 0 An interrupt is sent to the interrupt controller when the SCOLLGF bit in the EMACMMCTXRIS register is set. 1 The SCOLLGF interrupt is suppressed and not sent to the interrupt controller.

Bit/Field	Name	Type	Reset	Description
13:2	reserved	RO	0	Software should not rely on the value of a reserved bit. To provide compatibility with future products, the value of a reserved bit should be preserved across a read-modify-write operation.
1	GBF	RW	0x0	MMC Transmit Good Bad Frame Counter Interrupt Mask Value Description 0 An interrupt is sent to the interrupt controller when the GBF bit in the EMACMMCTXRIS register is set. 1 The GBF interrupt is suppressed and not sent to the interrupt controller.
0	reserved	RO	0	Software should not rely on the value of a reserved bit. To provide compatibility with future products, the value of a reserved bit should be preserved across a read-modify-write operation.

Register 28: Ethernet MAC Transmit Frame Count for Good and Bad Frames (EMACTXCNTGB), offset 0x118

The **MAC Transmit Frame Count for Good and Bad Frames (EMACTXCNTGB)** register maintains the number of good and bad frames transmitted, exclusive of retried frames.

Note: This counter is reset to all zeros by setting the **CNTRST** bit in the **Ethernet MAC MMC Control (EMACMMCCTRL)**, offset 0x100.

Ethernet MAC Transmit Frame Count for Good and Bad Frames (EMACTXCNTGB)

Base 0x400E.C000

Offset 0x118

Type RO, reset 0x0000.0000

	31	30	29	28	27	26	25	24	23	22	21	20	19	18	17	16
	TXFRMGB															
Type	RO	RO	RO	RO	RO	RO	RO	RO	RO	RO	RO	RO	RO	RO	RO	RO
Reset	0	0	0	0	0	0	0	0	0	0	0	0	0	0	0	0
	15	14	13	12	11	10	9	8	7	6	5	4	3	2	1	0
	TXFRMGB															
Type	RO	RO	RO	RO	RO	RO	RO	RO	RO	RO	RO	RO	RO	RO	RO	RO
Reset	0	0	0	0	0	0	0	0	0	0	0	0	0	0	0	0

Bit/Field	Name	Type	Reset	Description
31:0	TXFRMGB	RO	0x0	This field indicates the number of good and bad frames transmitted, exclusive of retried frames

Register 29: Ethernet MAC Transmit Frame Count for Frames Transmitted after Single Collision (EMACTXCNTSCOL), offset 0x14C

This register maintains the number of successfully transmitted frames after a single collision in the half-duplex mode.

Note: This counter is reset to all zeros by setting the `CNTRST` bit in the **Ethernet MAC MMC Control (EMACMMCCTRL)**, offset 0x100.

Ethernet MAC Transmit Frame Count for Frames Transmitted after Single Collision (EMACTXCNTSCOL)

Base 0x400E.C000
 Offset 0x14C
 Type RO, reset 0x0000.0000

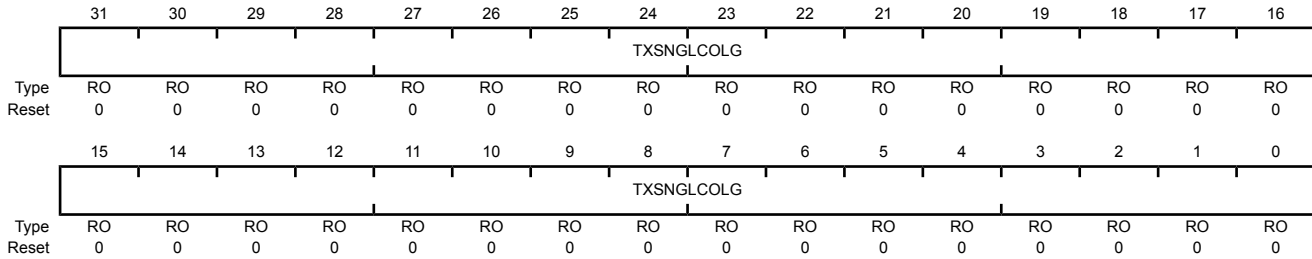

Bit/Field	Name	Type	Reset	Description
31:0	TXSNGLCOLG	RO	0x0	This field indicates the number of successfully transmitted frames after a single collision in the half-duplex mode.

Register 30: Ethernet MAC Transmit Frame Count for Frames Transmitted after Multiple Collisions (EMACTXCNTMCOL), offset 0x150

This register maintains the number of successfully transmitted frames after multiple collisions in the half-duplex mode.

Note: This counter is reset to all zeros by setting the `CNTRST` bit in the **Ethernet MAC MMC Control (EMACMMCCTRL)**, offset 0x100.

Ethernet MAC Transmit Frame Count for Frames Transmitted after Multiple Collisions (EMACTXCNTMCOL)

Base 0x400E.C000

Offset 0x150

Type RO, reset 0x0000.0000

	31	30	29	28	27	26	25	24	23	22	21	20	19	18	17	16
	TXMULTCOLG															
Type	RO	RO	RO	RO	RO	RO	RO	RO	RO	RO	RO	RO	RO	RO	RO	RO
Reset	0	0	0	0	0	0	0	0	0	0	0	0	0	0	0	0
	15	14	13	12	11	10	9	8	7	6	5	4	3	2	1	0
	TXMULTCOLG															
Type	RO	RO	RO	RO	RO	RO	RO	RO	RO	RO	RO	RO	RO	RO	RO	RO
Reset	0	0	0	0	0	0	0	0	0	0	0	0	0	0	0	0

Bit/Field	Name	Type	Reset	Description
31:0	TXMULTCOLG	RO	0x0	This field indicates the number of successfully transmitted frames after multiple collisions in the half-duplex mode.

Register 31: Ethernet MAC Transmit Octet Count Good (EMACTXOCTCNTG), offset 0x164

This register maintains the number of bytes transmitted, exclusive of preamble, only in good frames.

Note: This counter is reset to all zeros by setting the `CNTRST` bit in the **Ethernet MAC MMC Control (EMACMMCCTRL)**, offset 0x100.

Ethernet MAC Transmit Octet Count Good (EMACTXOCTCNTG)

Base 0x400E.C000
 Offset 0x164
 Type RO, reset 0x0000.0000

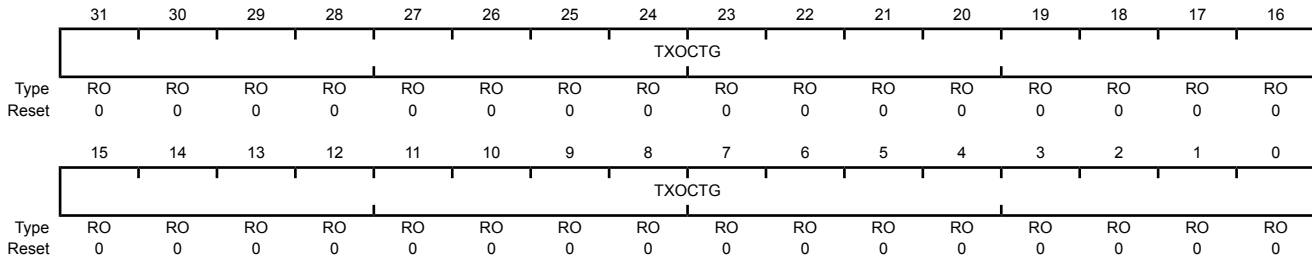

Bit/Field	Name	Type	Reset	Description
31:0	TXOCTG	RO	0x0	This field indicates the number of bytes transmitted, exclusive of preamble, in good frames.

Register 32: Ethernet MAC Receive Frame Count for Good and Bad Frames (EMACRXCNTGB), offset 0x180

This register maintains the number of received good and bad frames.

Note: This counter is reset to all zeros by setting the `CNTRST` bit in the **Ethernet MAC MMC Control (EMACMMCCTRL)**, offset 0x100.

Ethernet MAC Receive Frame Count for Good and Bad Frames (EMACRXCNTGB)

Base 0x400E.C000

Offset 0x180

Type RO, reset 0x0000.0000

	31	30	29	28	27	26	25	24	23	22	21	20	19	18	17	16
	RXFRMGB															
Type	RO	RO	RO	RO	RO	RO	RO	RO	RO	RO	RO	RO	RO	RO	RO	RO
Reset	0	0	0	0	0	0	0	0	0	0	0	0	0	0	0	0
	15	14	13	12	11	10	9	8	7	6	5	4	3	2	1	0
	RXFRMGB															
Type	RO	RO	RO	RO	RO	RO	RO	RO	RO	RO	RO	RO	RO	RO	RO	RO
Reset	0	0	0	0	0	0	0	0	0	0	0	0	0	0	0	0

Bit/Field	Name	Type	Reset	Description
31:0	RXFRMGB	RO	0x0	This field indicates the number of received good and bad frames.

Register 33: Ethernet MAC Receive Frame Count for CRC Error Frames (EMACRXCNTCRCERR), offset 0x194

This register maintains the number of frames received with CRC error.

Note: This counter is reset to all zeros by setting the `CNTRST` bit in the **Ethernet MAC MMC Control (EMACMMCCTRL)**, offset 0x100.

Ethernet MAC Receive Frame Count for CRC Error Frames (EMACRXCNTCRCERR)

Base 0x400E.C000

Offset 0x194

Type RO, reset 0x0000.0000

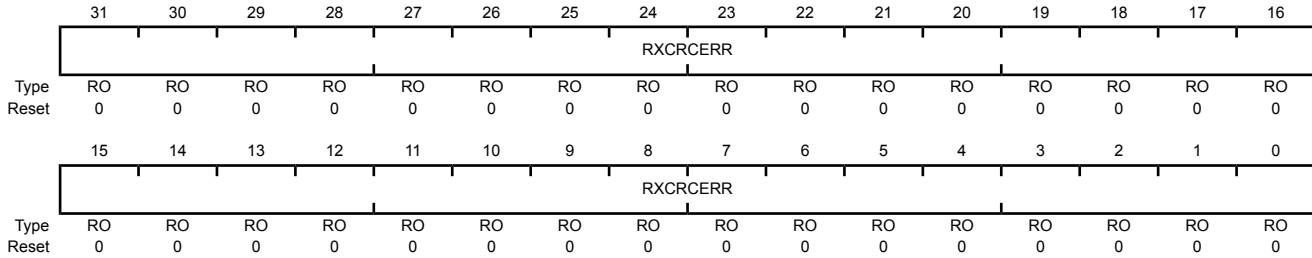

Bit/Field	Name	Type	Reset	Description
31:0	RXCRCERR	RO	0x0	This field indicates the number of frames received with CRC error.

Register 34: Ethernet MAC Receive Frame Count for Alignment Error Frames (EMACRXCNTALGNERR), offset 0x198

This register maintains the number of frames received with alignment (dribble) error.

Note: This counter is reset to all zeros by setting the `CNTRST` bit in the **Ethernet MAC MMC Control (EMACMMCCTRL)**, offset 0x100.

Ethernet MAC Receive Frame Count for Alignment Error Frames (EMACRXCNTALGNERR)

Base 0x400E.C000

Offset 0x198

Type RO, reset 0x0000.0000

	31	30	29	28	27	26	25	24	23	22	21	20	19	18	17	16
	RXALGNERR															
Type	RO	RO	RO	RO	RO	RO	RO	RO	RO	RO	RO	RO	RO	RO	RO	RO
Reset	0	0	0	0	0	0	0	0	0	0	0	0	0	0	0	0
	15	14	13	12	11	10	9	8	7	6	5	4	3	2	1	0
	RXALGNERR															
Type	RO	RO	RO	RO	RO	RO	RO	RO	RO	RO	RO	RO	RO	RO	RO	RO
Reset	0	0	0	0	0	0	0	0	0	0	0	0	0	0	0	0

Bit/Field	Name	Type	Reset	Description
31:0	RXALGNERR	RO	0x0	This field indicates the number of frames received with alignment (dribble) error.

Register 35: Ethernet MAC Receive Frame Count for Good Unicast Frames (EMACRXCNTGUNI), offset 0x1C4

This register maintains the number of received good unicast frames.

Note: This counter is reset to all zeros by setting the `CNTRST` bit in the **Ethernet MAC MMC Control (EMACMMCCTRL)**, offset 0x100.

Ethernet MAC Receive Frame Count for Good Unicast Frames (EMACRXCNTGUNI)

Base 0x400E.C000
 Offset 0x1C4
 Type RO, reset 0x0000.0000

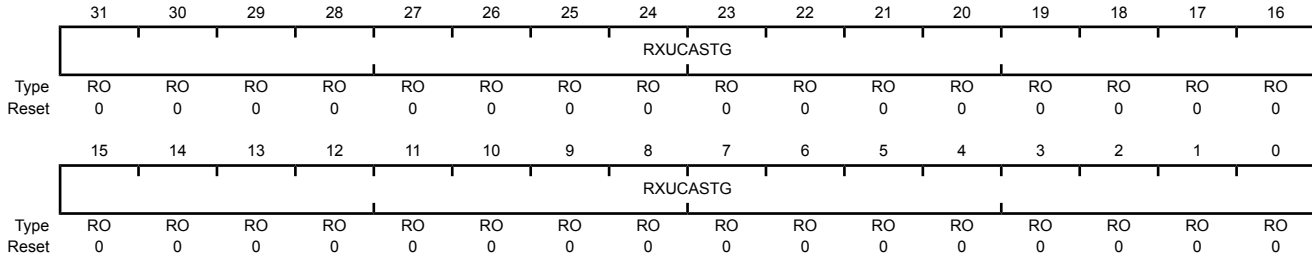

Bit/Field	Name	Type	Reset	Description
31:0	RXUCASTG	RO	0x0	This field indicates the number of received good unicast frames.

Register 36: Ethernet MAC VLAN Tag Inclusion or Replacement (EMACVLNINCREP), offset 0x584

The **MAC VLAN Tag Inclusion or Replacement (EMACVLNINCREP)** register contains the VLAN tag for insertion or replacement in the transmit frames.

Ethernet MAC VLAN Tag Inclusion or Replacement (EMACVLNINCREP)

Base 0x400E.C000

Offset 0x584

Type RW, reset 0x0000.0000

	31	30	29	28	27	26	25	24	23	22	21	20	19	18	17	16	
	reserved												CSVL	VLP	VLC		
Type	RO	RO	RO	RO	RO	RO	RO	RO	RO	RO	RO	RO	RW	RW	RW	RW	
Reset	0	0	0	0	0	0	0	0	0	0	0	0	0	0	0	0	
	15	14	13	12	11	10	9	8	7	6	5	4	3	2	1	0	
	VLT																
Type	RW	RW	RW	RW	RW	RW	RW	RW	RW	RW	RW	RW	RW	RW	RW	RW	RW
Reset	0	0	0	0	0	0	0	0	0	0	0	0	0	0	0	0	0

Bit/Field	Name	Type	Reset	Description
31:20	reserved	RO	0x0	Software should not rely on the value of a reserved bit. To provide compatibility with future products, the value of a reserved bit should be preserved across a read-modify-write operation.
19	CSVL	RW	0x0	C-VLAN or S-VLAN Value Description 0 C-VLAN type (0x8100) is inserted or replaced in the transmitted frames. 1 S-VLAN type (0x88A8) is inserted or replaced in the 13th and 14th bytes of transmitted frames.
18	VLP	RW	0x0	VLAN Priority Control Value Description 0 The control input from the transmit descriptor is used, and the VLC bit field (bits [17:16]) is ignored. 1 The VLC bit field is used for VLAN deletion, insertion, or replacement.

Bit/Field	Name	Type	Reset	Description
17:16	VLC	RW	0x0	<p>VLAN Tag Control in Transmit Frames</p> <p>Value Description</p> <p>0x0 No VLAN tag deletion, insertion, or replacement</p> <p>0x1 VLAN tag deletion The MAC removes the VLAN type (bytes 13 and 14) and VLAN tag (bytes 15 and 16) of all transmitted frames with VLAN tags.</p> <p>0x2 VLAN tag insertion The MAC inserts <code>VLT</code> in bytes 15 and 16 of the frame after inserting the Type value (0x8100/0x88a8) in bytes 13 and 14. This operation is performed on all transmitted frames, irrespective of whether they already have a VLAN tag.</p> <p>0x3 VLAN tag replacement The MAC replaces <code>VLT</code> in bytes 15 and 16 of all VLAN-type transmitted frames (Bytes 13 and 14 are 0x8100/0x88a8).</p> <p>Note: Changes to this field take effect only on the start of a frame. If you write this register field when a frame is being transmitted, only the subsequent frame can use the updated value, that is, the current frame does not use the updated value.</p>
15:0	VLT	RW	0x0	<p>VLAN Tag for Transmit Frames</p> <p>This field contains the value of the VLAN tag to be inserted or replaced. The value must only be changed when the transmit lines are inactive or during the initialization phase. Bits[15:13] are the User Priority, Bit 12 is the CFI/DEI, and Bits[11:0] are the VLAN tag's VID field.</p>

Register 37: Ethernet MAC VLAN Hash Table (EMACVLANTG), offset 0x588

The 16-bit hash table is used for group address filtering based on VLAN tag when the V_{THM} bit of the **EMACVLANTG** register is set. For hash filtering, the content of the 16-bit VLAN tag or 12-bit VLAN ID (enabled by ETV in the **EMACVLANTG** register) in the incoming frame is passed through the CRC logic and the upper four bits of the calculated CRC are used to index the contents of the **EMACVLANTG** register. For example, a hash value of 0x8 selects bit 8 of the VLAN Hash table. The hash value of the destination address is calculated in the following way:

1. Calculate the 32-bit CRC for the VLAN tag or ID (See IEEE 802.3, Section 3.2.8 for the steps to calculate CRC32).
2. Perform bitwise reversal for the value obtained in Step 1.
3. Take the upper four bits from the value obtained in Step 2.

If the corresponding bit value of the register is 0x1, the frame is accepted. Otherwise, it is rejected.

Ethernet MAC VLAN Hash Table (EMACVLANTG)

Base 0x400E.C000

Offset 0x588

Type RW, reset 0x0000.0000

	31	30	29	28	27	26	25	24	23	22	21	20	19	18	17	16
	reserved															
Type	RO	RO	RO	RO	RO	RO	RO	RO	RO	RO	RO	RO	RO	RO	RO	RO
Reset	0	0	0	0	0	0	0	0	0	0	0	0	0	0	0	0
	15	14	13	12	11	10	9	8	7	6	5	4	3	2	1	0
	VLHT															
Type	RW	RW	RW	RW	RW	RW	RW	RW	RW	RW	RW	RW	RW	RW	RW	RW
Reset	0	0	0	0	0	0	0	0	0	0	0	0	0	0	0	0

Bit/Field	Name	Type	Reset	Description
31:16	reserved	RO	0x0	Software should not rely on the value of a reserved bit. To provide compatibility with future products, the value of a reserved bit should be preserved across a read-modify-write operation.
15:0	VLHT	RW	0x0	VLAN Hash Table This field contains the 16-bit VLAN Hash Table.

Register 38: Ethernet MAC Timestamp Control (EMACTIMSTCTRL), offset 0x700

This register controls the operation of the system time generator and the processing of Precision Time Protocol (PTP) packets for time-stamping in the receiver.

Ethernet MAC Timestamp Control (EMACTIMSTCTRL)

Base 0x400E.C000
 Offset 0x700
 Type RW, reset 0x0000.2000

	31	30	29	28	27	26	25	24	23	22	21	20	19	18	17	16
	reserved													PTPFLTR	SELPTP	
Type	RO	RO	RO	RO	RO	RO	RO	RO	RO	RO	RO	RO	RO	RW	RW	RW
Reset	0	0	0	0	0	0	0	0	0	0	0	0	0	0	0	0
	15	14	13	12	11	10	9	8	7	6	5	4	3	2	1	0
	TSMAS	TSEVNT	PTPIPV4	PTPIPV6	PTPETH	PTPVER2	DGTLBIN	ALLF	reserved	ADDREGUP	INTTRIG	TSUPDT	TSINIT	TSFCUPDT	TSEN	
Type	RW	RW	RW	RW	RW	RW	RW	RW	RO	RO	RW	RW	RW	RW	RW	RW
Reset	0	0	1	0	0	0	0	0	0	0	0	0	0	0	0	0

Bit/Field	Name	Type	Reset	Description
31:19	reserved	RO	0x0	Software should not rely on the value of a reserved bit. To provide compatibility with future products, the value of a reserved bit should be preserved across a read-modify-write operation.
18	PTPFLTR	RW	0x0	Enable MAC address for PTP Frame Filtering Value Description 0 No effect. 1 The Destination Address (DA) MAC address, that matches any MAC Address register is used to filter PTP frames when PTP is directly sent over Ethernet.
17:16	SELPTP	RW	0x0	Select PTP packets for Taking Snapshots These bits along with Bits 15 and 14 decide the set of PTP packet types for which a snapshot needs to be taken.
15	TSMAS	RW	0x0	Enable Snapshot for Messages Relevant to Master Value Description 0 The snapshot is taken for the messages relevant to the slave node. 1 The snapshot is taken only for the messages relevant to the master node.
14	TSEVNT	RW	0x0	Enable Timestamp Snapshot for Event Messages Value Description 0 The snapshot is taken for all messages except Announce, Management, and Signaling. 1 The timestamp snapshot is taken only for event messages (SYNC, Delay_Req, Pdelay_Req, or Pdelay_Resp).

Bit/Field	Name	Type	Reset	Description
13	PTPIPv4	RW	0x1	<p>Enable Processing of PTP Frames Sent over IPv4-UDP</p> <p>Value Description</p> <p>0 The MAC ignores PTP transported over UDP-IPv4 packets. This bit is set by default.</p> <p>1 The MAC receiver processes PTP packets encapsulated in UDP over IPv4 packets.</p>
12	PTPIPv6	RW	0x0	<p>Enable Processing of PTP Frames Sent Over IPv6-UDP</p> <p>Value Description</p> <p>0 The MAC ignores PTP transported over UDP-IPv6 packets.</p> <p>1 The MAC receiver processes PTP packets encapsulated in UDP over IPv6 packets.</p>
11	PTPETH	RW	0x0	<p>Enable Processing of PTP Over Ethernet Frames</p> <p>Value Description</p> <p>0 The MAC ignores PTP over Ethernet packets.</p> <p>1 The MAC receiver processes PTP packets encapsulated directly in Ethernet frames.</p>
10	PTPVER2	RW	0x0	<p>Enable PTP Packet Processing For Version 2 Format</p> <p>Value Description</p> <p>0 PTP packets are processed using the IEEE 1588 version 1 format.</p> <p>1 PTP packets are processed using the IEEE 1588 version 2 format.</p>
9	DGTLBIN	RW	0x0	<p>Timestamp Digital or Binary Rollover Control</p> <p>Value Description</p> <p>0 The TTSLO field of the EMACTARGNANO register, offset 0x720, rolls over after 0x7FFF_FFFF and increments the EMACTARGSEC register. The sub-second increment has to be programmed correctly depending on the MOSC frequency and the value of this bit.</p> <p>1 The EMACTARGNANO register rolls over after 0x3B9A.C9FF value (that is, 1 nanosecond accuracy) and increments the EMACTARGSEC register.</p>
8	ALLF	RW	0x0	<p>Enable Timestamp For All Frames</p> <p>Value Description</p> <p>0 No effect.</p> <p>1 Timestamp snapshots are enabled for all frames received by the MAC.</p>

Bit/Field	Name	Type	Reset	Description
7:6	reserved	RO	0x0	Software should not rely on the value of a reserved bit. To provide compatibility with future products, the value of a reserved bit should be preserved across a read-modify-write operation.
5	ADDREGUP	RW	0x0	<p>Addend Register Update</p> <p>Value Description</p> <p>0 No effect.</p> <p>1 When set, the content of the Timestamp Addend register is updated in the PTP block for fine correction. This is cleared when the update is completed. This register bit should be zero before setting it.</p>
4	INTRIG	RW	0x0	<p>Timestamp Interrupt Trigger Enable</p> <p>Value Description</p> <p>0 No effect.</p> <p>1 The timestamp interrupt is generated when the System Time becomes greater than the value written in the Ethernet MAC Target Time Seconds/Nanoseconds (EMACTARGSEC/EMACTARGNANO) registers. This bit is reset after the generation of the Timestamp Trigger Interrupt.</p>
3	TSUPDT	RW	0x0	<p>Timestamp Update</p> <p>This bit should be read zero before updating it. This bit is reset when the update is completed in hardware. The Timestamp Higher Word register is not updated.</p> <p>Value Description</p> <p>0 No effect.</p> <p>1 When set, the system time is updated (added or subtracted) with the value specified in EMACTIMSECU (System Time - Seconds Update Register) and EMACTIMNANOU (System Time - Nanoseconds Update Register).</p>
2	TSINIT	RW	0x0	<p>Timestamp Initialize</p> <p>This bit should read zero before updating it.</p> <p>Value Description</p> <p>0x0 This bit is reset when the initialization is complete.</p> <p>0x1 The system time is initialized (overwritten) with the value specified in the Ethernet MAC System Time-Seconds Update (EMACTIMSECU) and the Ethernet MAC System Time-Nanoseconds Update (EMACTIMNANOU) registers.</p>

Bit/Field	Name	Type	Reset	Description
1	TSFCUPDT	RW	0x0	<p>Timestamp Fine or Coarse Update</p> <p>Value Description</p> <p>0x0 Indicates the system timestamp update should be done using the coarse method.</p> <p>0x1 Indicates that the system times update should be done using the fine update method.</p>
0	TSEN	RW	0x0	<p>Timestamp Enable</p> <p>The EMACTIMSEC and the EMACTIMNANO registers must be initialized after enabling this mode. On the receive side, the MAC processes 1588 frames only if this bit is set.</p> <p>Value Description</p> <p>0x0 The timestamp is not added for the transmit and receive frames and the timestamp generator module is also suspended.</p> <p>0x1 The timestamp is added for the transmit and receive frames</p>

Register 39: Ethernet MAC Sub-Second Increment (EMACSUBSECINC), offset 0x704

In the Coarse Update mode (enabled by the `TSCFUPDT` bit in the **MAC Timestamp Control (EMACTIMSTCTRL)** register), the value in the **EMACSUBSECINC** register is added to the system time every clock cycle of slave clock reference, MOSC. In the Fine Update mode, the value in this register is added to the system time whenever the Accumulator gets an overflow.

Ethernet MAC Sub-Second Increment (EMACSUBSECINC)

Base 0x400E.C000

Offset 0x704

Type RW, reset 0x0000.0000

	31	30	29	28	27	26	25	24	23	22	21	20	19	18	17	16
	reserved															
Type	RO	RO	RO	RO	RO	RO	RO	RO	RO	RO	RO	RO	RO	RO	RO	RO
Reset	0	0	0	0	0	0	0	0	0	0	0	0	0	0	0	0
	15	14	13	12	11	10	9	8	7	6	5	4	3	2	1	0
	reserved								SSINC							
Type	RO	RO	RO	RO	RO	RO	RO	RO	RW	RW	RW	RW	RW	RW	RW	RW
Reset	0	0	0	0	0	0	0	0	0	0	0	0	0	0	0	0

Bit/Field	Name	Type	Reset	Description
31:8	reserved	RO	0x0	Software should not rely on the value of a reserved bit. To provide compatibility with future products, the value of a reserved bit should be preserved across a read-modify-write operation.
7:0	SSINC	RW	0x0	<p>Sub-second Increment Value</p> <p>The value programmed in this field is accumulated every clock cycle (MOSC) with the contents of the sub-second register. For example, when MOSC is 25 MHz (period is 40 ns), <code>SSINC</code> should be programmed with the value 40 (0x28) when the Ethernet MAC System Time - Nanoseconds (EMACTIMNANO) register has an accuracy of 1 ns (<code>DGTLBIN</code> bit is set in EMACTIMSTCTRL). When <code>DGTLBIN</code> bit is clear, the EMACTIMNANO register has a resolution of ~0.465ns. In this case, a value of 86 (0x56), that is derived by $40\text{ns}/0.465$, should be programmed in the <code>SSINC</code> field.</p>

Register 40: Ethernet MAC System Time - Seconds (EMACTIMSEC), offset 0x708

The **MAC System Time - Seconds (EMACTIMSEC)** register, along with the **MAC System Time - Nanoseconds (EMACTIMNANO)** register, indicates the current value of the system time maintained by the MAC. Though it is updated on a continuous basis, there is some delay from the actual time because of clock domain transfer latencies.

Ethernet MAC System Time - Seconds (EMACTIMSEC)

Base 0x400E.C000

Offset 0x708

Type RO, reset 0x0000.0000

	31	30	29	28	27	26	25	24	23	22	21	20	19	18	17	16
	TSS															
Type	RO	RO	RO	RO	RO	RO	RO	RO	RO	RO	RO	RO	RO	RO	RO	RO
Reset	0	0	0	0	0	0	0	0	0	0	0	0	0	0	0	0
	15	14	13	12	11	10	9	8	7	6	5	4	3	2	1	0
	TSS															
Type	RO	RO	RO	RO	RO	RO	RO	RO	RO	RO	RO	RO	RO	RO	RO	RO
Reset	0	0	0	0	0	0	0	0	0	0	0	0	0	0	0	0

Bit/Field	Name	Type	Reset	Description
31:0	TSS	RO	0x0	Timestamp Second The value in this field indicates the current value in seconds of the system time maintained by the MAC.

Register 41: Ethernet MAC System Time - Nanoseconds (EMACTIMNANO), offset 0x70C

The value in this field has the sub-second representation of time, with an accuracy of 0.46 ns. When DGTLBIN in the **EMACTIMSTCTRL** register is set, each bit represents 1 ns and the maximum value is 0x3B9A.C9FF, after which it rolls-over to zero.

Ethernet MAC System Time - Nanoseconds (EMACTIMNANO)

Base 0x400E.C000
 Offset 0x70C
 Type RO, reset 0x0000.0000

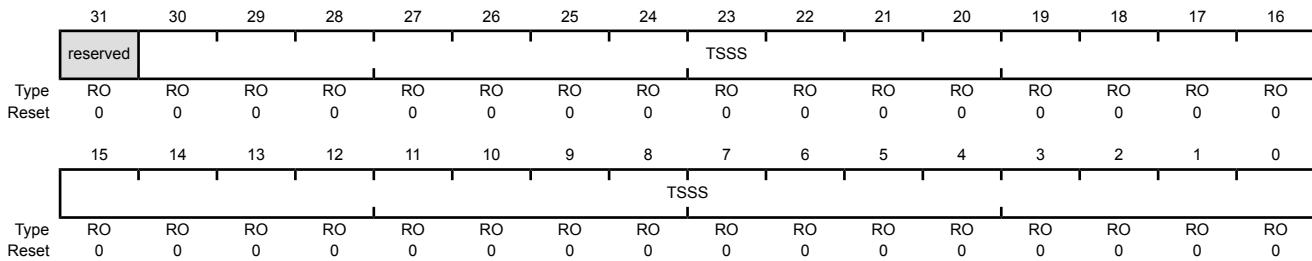

Bit/Field	Name	Type	Reset	Description
31	reserved	RO	0x0	Software should not rely on the value of a reserved bit. To provide compatibility with future products, the value of a reserved bit should be preserved across a read-modify-write operation.
30:0	TSSS	RO	0x0	Timestamp Sub-Seconds The value in this field has the sub-second representation of time, with an accuracy of 0.46 ns. When DGTLBIN in the EMACTIMSTCTRL register is set, each bit represents 1 ns and the maximum value is 0x3B9A.C9FF, after which it rolls-over to zero.

Register 42: Ethernet MAC System Time - Seconds Update (EMACTIMSECU), offset 0x710

The **MAC System Time - Seconds Update (EMACTIMSECU)** register, along with the **MAC System Time - Nanoseconds Update (EMACTIMNANOU)** register, initializes or updates the system time maintained by the MAC. Both of these register must be written before setting the **TSINIT** or **TSUPDT** bits in the **EMACTIMSTCTRL** register.

Ethernet MAC System Time - Seconds Update (EMACTIMSECU)

Base 0x400E.C000

Offset 0x710

Type RW, reset 0x0000.0000

	31	30	29	28	27	26	25	24	23	22	21	20	19	18	17	16
	TSS															
Type	RW	RW	RW	RW	RW	RW	RW	RW	RW	RW	RW	RW	RW	RW	RW	RW
Reset	0	0	0	0	0	0	0	0	0	0	0	0	0	0	0	0
	15	14	13	12	11	10	9	8	7	6	5	4	3	2	1	0
	TSS															
Type	RW	RW	RW	RW	RW	RW	RW	RW	RW	RW	RW	RW	RW	RW	RW	RW
Reset	0	0	0	0	0	0	0	0	0	0	0	0	0	0	0	0

Bit/Field	Name	Type	Reset	Description
31:0	TSS	RW	0x0	Timestamp Second The value in this field indicates the time in seconds to be initialized or added to the system time.

Register 43: Ethernet MAC System Time - Nanoseconds Update (EMACTIMNANOU), offset 0x714

This register along with the **EMACTIMSECU** register initializes or updates the system time maintained by the MAC. Both of these register must be written before setting the **TSINIT** or **TSUPDT** bits in the **EMACTIMSTCTRL** register.

Ethernet MAC System Time - Nanoseconds Update (EMACTIMNANOU)

Base 0x400E.C000

Offset 0x714

Type RW, reset 0x0000.0000

	31	30	29	28	27	26	25	24	23	22	21	20	19	18	17	16
	ADDSUB															
Type	RW	RW	RW	RW	RW	RW	RW	RW	RW	RW	RW	RW	RW	RW	RW	RW
Reset	0	0	0	0	0	0	0	0	0	0	0	0	0	0	0	0
	15	14	13	12	11	10	9	8	7	6	5	4	3	2	1	0
	TSSS															
Type	RW	RW	RW	RW	RW	RW	RW	RW	RW	RW	RW	RW	RW	RW	RW	RW
Reset	0	0	0	0	0	0	0	0	0	0	0	0	0	0	0	0

Bit/Field	Name	Type	Reset	Description
31	ADDSUB	RW	0x0	Add or subtract time Value Description 0x0 The time value is added with the contents of the update register. 0x1 The time value is subtracted with the contents of the update register.
30:0	TSSS	RW	0x0	Timestamp Sub-Second The value in this field has the sub-second representation of time, with an accuracy of 0.46 ns. When DGTLBIN in the EMACTIMSTCTRL register is set, each bit represents 1 ns and the programmed value should not exceed 0x3B9A.C9FF.

Register 44: Ethernet MAC Timestamp Addend (EMACTIMADD), offset 0x718

This register value is used only when the system time is configured for Fine Update mode (TSCFUPDPT bit is set in the **EMACTIMSTCTRL** register). This register content is added to a 32-bit accumulator every slave clock cycle (MOSC source) and the system time is updated whenever the accumulator overflows.

Ethernet MAC Timestamp Addend (EMACTIMADD)

Base 0x400E.C000

Offset 0x718

Type RW, reset 0x0000.0000

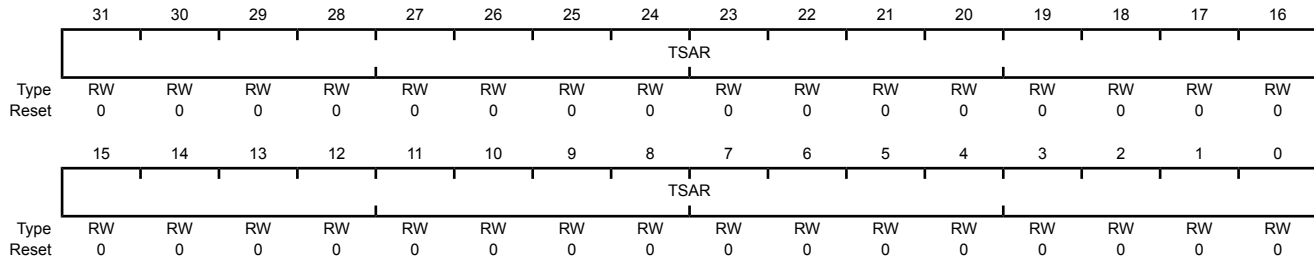

Bit/Field	Name	Type	Reset	Description
31:0	TSAR	RW	0x0	Timestamp Addend Register This field indicates the 32-bit time value to be added to the Accumulator register to achieve time synchronization.

Register 45: Ethernet MAC Target Time Seconds (EMACTARGSEC), offset 0x71C

The **MAC Target Time Seconds (EMACTARGSEC)** register, along with the **MAC Target Time Nanoseconds (EMACTARGNANO)** register, is used to schedule an interrupt event.

Ethernet MAC Target Time Seconds (EMACTARGSEC)

Base 0x400E.C000

Offset 0x71C

Type RW, reset 0x0000.0000

	31	30	29	28	27	26	25	24	23	22	21	20	19	18	17	16
	TSTR															
Type	RW	RW	RW	RW	RW	RW	RW	RW	RW	RW	RW	RW	RW	RW	RW	RW
Reset	0	0	0	0	0	0	0	0	0	0	0	0	0	0	0	0
	15	14	13	12	11	10	9	8	7	6	5	4	3	2	1	0
	TSTR															
Type	RW	RW	RW	RW	RW	RW	RW	RW	RW	RW	RW	RW	RW	RW	RW	RW
Reset	0	0	0	0	0	0	0	0	0	0	0	0	0	0	0	0

Bit/Field	Name	Type	Reset	Description
31:0	TSTR	RW	0x0	<p>Target Time Seconds Register</p> <p>This register stores the time in seconds. When the timestamp value matches or exceeds both the MAC Target Time Seconds (EMACTARGSEC) and MAC Target Time Nanoseconds (EMACTARGNANO) registers, then based on the TRGMODS0 bit field in the MAC PPS Control (EMACPPSCTRL), the MAC starts or stops the PPS signal output and generates an interrupt (if enabled).</p>

Register 46: Ethernet MAC Target Time Nanoseconds (EMACTARGNANO), offset 0x720

The **MAC Target Time Seconds (EMACTARGSEC)** register, along with the **MAC Target Time Nanoseconds (EMACTARGNANO)** register, is used to schedule an interrupt event.

Ethernet MAC Target Time Nanoseconds (EMACTARGNANO)

Base 0x400E.C000

Offset 0x720

Type RW, reset 0x0000.0000

	31	30	29	28	27	26	25	24	23	22	21	20	19	18	17	16
	TRGTBUSY															
Type	RW	RW	RW	RW	RW	RW	RW	RW	RW	RW	RW	RW	RW	RW	RW	RW
Reset	0	0	0	0	0	0	0	0	0	0	0	0	0	0	0	0
	15	14	13	12	11	10	9	8	7	6	5	4	3	2	1	0
	TTSLO															
Type	RW	RW	RW	RW	RW	RW	RW	RW	RW	RW	RW	RW	RW	RW	RW	RW
Reset	0	0	0	0	0	0	0	0	0	0	0	0	0	0	0	0

Bit/Field	Name	Type	Reset	Description
31	TRGTBUSY	RW	0x0	<p>Target Time Register Busy</p> <p>This bit is set and cleared by the MAC.</p> <p>Value Description</p> <p>0 The Ethernet MAC Target Time Seconds/Nanoseconds (EMACTARGSEC/EMACTARGNANO) registers are not busy.</p> <p>1 The Ethernet MAC Target Time Seconds/Nanoseconds (EMACTARGSEC/EMACTARGNANO) registers are busy. This bit is set when the PPSCTRL field in the EMACPPSCTRL register is programmed to 0x2 or 0x3 and the MAC is instructed to synchronize the EMACTARGSEC/EMACTARGNANO registers to the PTP clock domain.</p> <p>Note: The EMACTARGSEC and EMACTARGNANO registers must not be updated when this bit is read as 1.</p>
30:0	TTSLO	RW	0x0	<p>Target Timestamp Low Register</p> <p>This register stores the time in (signed) nanoseconds. When the value of the timestamp matches both EMACTARGx registers, the MAC starts or stops the PPS signal output and generates an interrupt (if enabled) based on the TRGMODS0 field in the MAC PPS Control (EMACPPSCTRL) register.</p> <p>This value should not exceed 0x3B9A.C9FF when DGTLBIN is set in the EMACTIMSTCTRL register. The actual start or stop time of the PPS signal output may have an error margin up to one unit of sub-second increment value.</p>

Register 47: Ethernet MAC System Time-Higher Word Seconds (EMACHWORDSEC), offset 0x724

This register is used to support the most significant 16-bits of the timestamp seconds value.

Ethernet MAC System Time-Higher Word Seconds (EMACHWORDSEC)

Base 0x400E.C000

Offset 0x724

Type RW, reset 0x0000.0000

	31	30	29	28	27	26	25	24	23	22	21	20	19	18	17	16
	reserved															
Type	RO	RO	RO	RO	RO	RO	RO	RO	RO	RO	RO	RO	RO	RO	RO	RO
Reset	0	0	0	0	0	0	0	0	0	0	0	0	0	0	0	0
	15	14	13	12	11	10	9	8	7	6	5	4	3	2	1	0
	TSHWR															
Type	RW	RW	RW	RW	RW	RW	RW	RW	RW	RW	RW	RW	RW	RW	RW	RW
Reset	0	0	0	0	0	0	0	0	0	0	0	0	0	0	0	0

Bit/Field	Name	Type	Reset	Description
31:16	reserved	RO	0x0	Software should not rely on the value of a reserved bit. To provide compatibility with future products, the value of a reserved bit should be preserved across a read-modify-write operation.
15:0	TSHWR	RW	0x0	Target Timestamp Higher Word Register This field contains the most significant 16-bits of the timestamp seconds value. The register is directly written to initialize the value. This register is incremented when there is an overflow from the 32-bits of the System Time - Seconds register.

Register 48: Ethernet MAC Timestamp Status (EMACTIMSTAT), offset 0x728

Ethernet MAC Timestamp Status (EMACTIMSTAT)

Base 0x400E.C000

Offset 0x728

Type RO, reset 0x0000.0000

	31	30	29	28	27	26	25	24	23	22	21	20	19	18	17	16	
	reserved																
Type	RO	RO	RO	RO	RO	RO	RO	RO	RO	RO	RO	RO	RO	RO	RO	RO	
Reset	0	0	0	0	0	0	0	0	0	0	0	0	0	0	0	0	
	15	14	13	12	11	10	9	8	7	6	5	4	3	2	1	0	
	reserved															TSTARGET	TSSOVF
Type	RO	RO	RO	RO	RO	RO	RO	RO	RO	RO	RO	RO	RO	RO	RO	RO	RO
Reset	0	0	0	0	0	0	0	0	0	0	0	0	0	0	0	0	0

Bit/Field	Name	Type	Reset	Description
31:2	reserved	RO	0x0	Software should not rely on the value of a reserved bit. To provide compatibility with future products, the value of a reserved bit should be preserved across a read-modify-write operation.
1	TSTARGET	RO	0x0	Timestamp Target Time Reached Value Description 0x0 Target Time has not been reached. 0x1 Indicates that the value of system time is greater or equal to the value specified in EMACTARGSEC (Target Time Seconds Register) and EMACTARGNANO (Target Time Nanoseconds Register).
0	TSSOVF	RO	0x0	Timestamp Seconds Overflow Value Description 0x0 No timestamp overflow has occurred. 0x1 Indicates the seconds value of the timestamp has overflowed beyond 0xFFFF.FFFF.

Register 49: Ethernet MAC PPS Control (EMACPPSCTRL), offset 0x72C

This register is used to control the EN0PPS signal output.

Note: The PTP reference clock referred to below is MOSC clock in course update mode and in fine correction mode, is the clock tick at which the system time gets updated.

Ethernet MAC PPS Control (EMACPPSCTRL)

Base 0x400E.C000

Offset 0x72C

Type RW, reset 0x0000.0000

	31	30	29	28	27	26	25	24	23	22	21	20	19	18	17	16
	reserved															
Type	RO	RO	RO	RO	RO	RO	RO	RO	RO	RO	RO	RO	RO	RO	RO	RO
Reset	0	0	0	0	0	0	0	0	0	0	0	0	0	0	0	0
	15	14	13	12	11	10	9	8	7	6	5	4	3	2	1	0
	reserved										TRGMODS0	PPSEN0	PPSCTRL			
Type	RO	RO	RO	RO	RO	RO	RO	RO	RO	RO	RO	RO	RW	RW	RW	RW
Reset	0	0	0	0	0	0	0	0	0	0	0	0	0	0	0	0

Bit/Field	Name	Type	Reset	Description
31:7	reserved	RO	0x0	Software should not rely on the value of a reserved bit. To provide compatibility with future products, the value of a reserved bit should be preserved across a read-modify-write operation.
6:5	TRGMODS0	RO	0x0	Target Time Register Mode for PPS0 Output This field indicates the Target Time registers (EMACTARGSEC and EMACTARGNANO) mode for the EN0PPS output signal: Value Description 0x0 Indicates that the Target Time registers are programmed only for generating the interrupt event. 0x1 Reserved 0x2 Indicates that the Target Time registers are programmed for generating the interrupt event and starting or stopping the generation of the EN0PPS output signal. 0x3 Indicates that the Target Time registers are programmed only for starting or stopping the generation of the EN0PPS output signal. No interrupt is asserted.
4	PPSEN0	RO	0x0	Flexible PPS Output Mode Enable Value Description 0x0 Bits[3:0] function as PPS output frequency control (PPSCTRL). 0x1 Bits[3:0] function as PPS Command (PPSCMD).

Bit/Field	Name	Type	Reset	Description
3:0	PPSCTRL	RW	0x0	<p>EN0PPS Output Frequency Control (PPSCTRL) or Command Control (PPSCMD)</p> <p>This bit field has two different functions depending on how the PPSEN0 bit is set. See the values in Table 23-24 on page 1673.</p> <p>If the PPSEN0 bit is set to 0x0, this field functions as a PPS0 output frequency control (PPSCTRL), which controls the frequency of the output signal, EN0PPS. The default value of this field is 0x0 and the PPS output is one pulse every second.</p> <p>If the PPSEN0 bit is 0x1, this field functions as a flexible output command control for the EN0PPS signal. Programming the PPSCTRL bit field with a non-zero value instructs the MAC to initiate an event. When the command is transferred or synchronized to the PTP clock domain, these bits are cleared automatically. Software should ensure that these bits are programmed only when they are "all-zeros."</p> <p>Note that in the binary rollover mode, the EN0PPS signal has a duty cycle of 50 percent with these frequencies.</p> <p>In the digital rollover mode, the EN0PPS signal frequency is an average number. The actual clock is of different frequency that gets synchronized every second. For example:</p> <p>When PPSCTRL = 0x1, EN0PPS (1 Hz) has a low period of 537 ms and a high period of 463 ms.</p> <p>When PPSCTRL = 0x2, EN0PPS (2 Hz) is a sequence of:</p> <ul style="list-style-type: none"> ■ One clock of 50 percent duty cycle and 537 ms period ■ Second clock of 463 ms period (268 ms low and 195 ms high) <p>When PPSCTRL = 0x3, EN0PPS (4 Hz) is a sequence of:</p> <ul style="list-style-type: none"> ■ Three clocks of 50 percent duty cycle and 268 ms period ■ Fourth clock of 195 ms period (134 ms low and 61 ms high) <p>This signaling behavior is because of the non-linear toggling of bits in the digital rollover mode in the Ethernet MAC System Time - Nanoseconds (EMACTIMNANO) register.</p>

Table 23-24. PPSCTRL Bit Field Values

Value	Description
0x0	<p>When the PPSEN0 bit = 0x0, the EN0PPS signal is 1 pulse of the PTP reference clock. every second.</p> <p>When the PPSEN0 bit = 0x1, this encoding indicates no command.</p>
0x1	<p>When the PPSEN0 bit = 0x0, the binary rollover is 2 Hz, and the digital rollover is 1 Hz.</p> <p>When the PPSEN0 bit = 0x1, START single pulse. This command generates a single pulse rising at the start point defined in the Ethernet MAC Target Time Second/Nanoseconds (EMACTARGX) registers (MAC offsets 0x71C and 0x720) and a duration defined in the Ethernet MAC PPS0 Width (EMACPPS0WIDTH) register (offset 0x764).</p>
0x2	<p>When the PPSEN0 bit = 0x0, the binary rollover is 4 Hz, and the digital rollover is 2 Hz.</p> <p>When the PPSEN0 bit = 0x1, START pulse train. This command generates the train of pulses rising at the start point defined in the Ethernet MAC Target Time Second/Nanoseconds (EMACTARGX) registers (MAC offsets 0x71C and 0x720) and repeated at an interval defined in the Ethernet MAC PPS0 Width (EMACPPS0WIDTH) register (offset 0x764). By default, the EN0PPS pulse train is free-running unless stopped by STOP pulse train at a time or STOP pulse train immediately command.</p>
0x3	<p>When the PPSEN0 bit = 0x0, the binary rollover is 8 Hz, and the digital rollover is 4 Hz,</p>

Table 23-24. PPCTRL Bit Field Values (continued)

Value	Description
	When the PPSEN0 bit = 0x1, cancel START. This command cancels the START single pulse and START pulse train commands if the system time has not crossed the programmed start time.
0x4	When the PPSEN0 bit = 0x0, the binary rollover is 16 Hz, and the digital rollover is 8 Hz. When the PPSEN0 bit = 0x1, STOP pulse train at time. This command stops the train of pulses initiated by the START pulse train command after the time programmed in the Ethernet MAC Target Time Second/Nanoseconds (EMACTARGX) registers (MAC offsets 0x71C and 0x720).
0x5	When the PPSEN0 bit = 0x0, the binary rollover is 32 Hz, and the digital rollover is 16 Hz. When the PPSEN0 bit = 0x1, STOP pulse train immediately. This command immediately stops the train of pulses initiated by the START pulse train command.
0x6	When the PPSEN0 bit = 0x0, the binary rollover is 64 Hz, and the digital rollover is 32 Hz. When the PPSEN0 bit = 0x1, cancel STOP pulse train. This command cancels the STOP pulse train at the time command if the programmed stop time has not elapsed. The EN0PPS pulse train becomes free-running on the successful execution of this command.
0x7	When the PPSEN0 bit = 0x0, the binary rollover is 128 Hz, and the digital rollover is 64 Hz. When the PPSEN0 bit = 0x1, this encoding is reserved.
0x8	When the PPSEN0 bit = 0x0, the binary rollover is 256 Hz, and the digital rollover is 128 Hz. When the PPSEN0 bit = 0x1, this encoding is reserved.
0x9	When the PPSEN0 bit = 0x0, the binary rollover is 512 Hz, and the digital rollover is 256 Hz. When the PPSEN0 bit = 0x1, this encoding is reserved.
0xA	When the PPSEN0 bit = 0x0, the binary rollover is 1.024 kHz, and the digital rollover is 512 Hz. When the PPSEN0 bit = 0x1, this encoding is reserved.
0xB	When the PPSEN0 bit = 0x0, the binary rollover is 2.048 kHz, and the digital rollover is 1.024 kHz. When the PPSEN0 bit = 0x1, this encoding is reserved.
0xC	When the PPSEN0 bit = 0x0, the binary rollover is 4.096 kHz, and the digital rollover is 2.048 kHz. When the PPSEN0 bit = 0x1, this encoding is reserved.
0xD	When the PPSEN0 bit = 0x0, the binary rollover is 8.192 kHz, and the digital rollover is 4.096 kHz. When the PPSEN0 bit = 0x1, this encoding is reserved.
0xE	When the PPSEN0 bit = 0x0, the binary rollover is 16.384 kHz, and the digital rollover is 8.092 kHz. When the PPSEN0 bit = 0x1, this encoding is reserved.
0xF	When the PPSEN0 bit = 0x0, the binary rollover is 32.768 KHz, and the digital rollover is 16.384 KHz. When the PPSEN0 bit = 0x1, this encoding is reserved.

Register 50: Ethernet MAC PPS0 Interval (EMACPPS0INTVL), offset 0x760

The **MAC PPS0 Interval (EMACPPS0INTVL)** register contains the number of units of sub-second increment value between the rising edges of `EN0PPS` signal output.

Note: The PTP reference clock referred to below is MOSC clock in course update mode and in fine correction mode, is the clock tick at which the system time gets updated.

Ethernet MAC PPS0 Interval (EMACPPS0INTVL)

Base 0x400E.C000

Offset 0x760

Type RW, reset 0x0000.0000

	31	30	29	28	27	26	25	24	23	22	21	20	19	18	17	16
	PPS0INT															
Type	RW	RW	RW	RW	RW	RW	RW	RW	RW	RW	RW	RW	RW	RW	RW	RW
Reset	0	0	0	0	0	0	0	0	0	0	0	0	0	0	0	0
	15	14	13	12	11	10	9	8	7	6	5	4	3	2	1	0
	PPS0INT															
Type	RW	RW	RW	RW	RW	RW	RW	RW	RW	RW	RW	RW	RW	RW	RW	RW
Reset	0	0	0	0	0	0	0	0	0	0	0	0	0	0	0	0

Bit/Field	Name	Type	Reset	Description
31:0	PPS0INT	RW	0x0	<p>PPS0 Output Signal Interval</p> <p>These bits store the interval between the rising edges of the <code>EN0PPS</code> signal output in terms of units of sub-second increment value.</p> <p>It must be programmed one value less than the required interval. For example, if the PTP reference clock is 25 MHz (period of 40 ns), and desired interval between rising edges of <code>EN0PPS</code> signal output is 120 ns (that is, three units of sub-second increment value), then you should program value 2 (3 - 1) in this register.</p>

Register 51: Ethernet MAC PPS0 Width (EMACPPS0WIDTH), offset 0x764

The **MAC PPS0 Width (EMACPPS0WIDTH)** register contains the number of units of sub-second increment value between the rising and corresponding falling edges of the `EN0PPS` output signal.

Note: The PTP reference clock referred to below is MOSC clock in course update mode and in fine correction mode, is the clock tick at which the system time gets updated.

Ethernet MAC PPS0 Width (EMACPPS0WIDTH)

Base 0x400E.C000

Offset 0x764

Type RW, reset 0x0000.0000

	31	30	29	28	27	26	25	24	23	22	21	20	19	18	17	16
	PPS0WIDTH															
Type	RW	RW	RW	RW	RW	RW	RW	RW	RW	RW	RW	RW	RW	RW	RW	RW
Reset	0	0	0	0	0	0	0	0	0	0	0	0	0	0	0	0
	15	14	13	12	11	10	9	8	7	6	5	4	3	2	1	0
	PPS0WIDTH															
Type	RW	RW	RW	RW	RW	RW	RW	RW	RW	RW	RW	RW	RW	RW	RW	RW
Reset	0	0	0	0	0	0	0	0	0	0	0	0	0	0	0	0

Bit/Field	Name	Type	Reset	Description
31:0	PPS0WIDTH	RW	0x0	<p><code>EN0PPS</code> Output Signal Width</p> <p>These bits store the width between the rising edges and corresponding falling edge of the of the <code>EN0PPS</code> signal output in terms of units of sub-second increment value.</p> <p>It must be programmed one value less than the required interval. For example, if the PTP reference clock is 25 MHz (period of 40 ns), and the desired interval between rising edges of <code>EN0PPS</code> signal output is 80 ns (that is, two units of sub-second increment value), then you should program value 1 (2 - 1) in this register.</p> <p>Note: The value programmed in this register must be less than the value programmed in the Ethernet MAC PPS0 Interval (EMACPPS0INTVL) register, offset 0x760.</p>

Register 52: Ethernet MAC DMA Bus Mode (EMACDMABUSMOD), offset 0xC00

The **Ethernet MAC DMA Bus Mode (EMACDMABUSMODE)** register establishes the operation modes for the DMA.

Ethernet MAC DMA Bus Mode (EMACDMABUSMOD)

Base 0x400E.C000

Offset 0xC00

Type RW, reset 0x0002.0101

	31	30	29	28	27	26	25	24	23	22	21	20	19	18	17	16	
	RIB	reserved				TXPR	MB	AAL	8xPBL	USP	RPBL						FB
Type	RW	RO	RO	RO	RW	RW	RW	RW	RW	RW	RW	RW	RW	RW	RW	RW	
Reset	0	0	0	0	0	0	0	0	0	0	0	0	0	0	1	0	
	15	14	13	12	11	10	9	8	7	6	5	4	3	2	1	0	
	PR		PBL				ATDS		DSL				DA	SWR			
Type	RW	RW	RW	RW	RW	RW	RW	RW	RW	RW	RW	RW	RW	RW	RW	RW	
Reset	0	0	0	0	0	0	0	1	0	0	0	0	0	0	0	1	

Bit/Field	Name	Type	Reset	Description
31	RIB	RW	0x0	Rebuild Burst Value Description 0x0 During a retry, split or loss of bus, the DMA rebuilds the pending beats of any burst transfer with a continuous, uninterrupted burst until the last word, which is a single burst. 0x1 During a retry, split or loss of bus, the DMA rebuilds the pending beats of any burst transfer initiated with a defined fixed burst of 1, 4, 8, or 16.
30:28	reserved	RO	0x0	Software should not rely on the value of a reserved bit. To provide compatibility with future products, the value of a reserved bit should be preserved across a read-modify-write operation.
27	TXPR	RW	0	Transmit Priority Value Description 0x0 The RX DMA has higher priority than the TX DMA during arbitration for the system bus. 0x1 The TX DMA has higher priority than the RX DMA during arbitration for the system bus.
26	MB	RW	0	Mixed Burst Value Description 0x0 Mixed burst is not enabled. 0x1 If the FB bit is 0, the DMA starts all bursts of length more than 16 with a continuous undefined burst. For bursts less than 16, fixed and single bursts are used.

Bit/Field	Name	Type	Reset	Description
25	AAL	RW	0	<p>Address Aligned Beats</p> <p>Value Description</p> <p>0x0 Address aligned transfers are not enabled.</p> <p>0x1 If the <code>FB</code> bit is set, the internal bus interface generates all bursts aligned to the start address least significant bits. If the <code>FB</code> bit is 0, the first burst is not aligned but subsequent bursts are aligned to the address.</p>
24	8xPBL	RW	0	<p>8 x Programmable Burst Length (PBL) Mode</p> <p>Value Description</p> <p>0x0 8 x PBL mode is inactive.</p> <p>0x1 Bit field <code>RPBL</code> and bit field <code>PBL</code> are multiplied 8 times. Therefore, the DMA transfers the data in bursts of 8, 16, 32, 64, 128, and 256 words.</p>
23	USP	RW	0	<p>Use Separate Programmable Burst Length (PBL)</p> <p>Value Description</p> <p>0x0 The <code>PBL</code> value in bits[13:8] is applicable for both the RX and TX DMA engines.</p> <p>0x1 RX DMA uses the <code>RPBL</code> bit field as its defined programmable burst length and TX DMA uses the <code>PBL</code> bit field as its defined programmable burst length.</p>
22:17	RPBL	RW	0x1	<p>RX DMA Programmable Burst Length (PBL)</p> <p>When the <code>USP</code> bit is 1, this field is used to indicate the maximum number of words to be transferred in one RX DMA transaction. This is the maximum value that is used in a single block read or write.</p> <p>The RX DMA always attempts to burst as specified in the <code>RPBL</code> bit each time it starts a burst transfer on the system bus. The application can program <code>RPBL</code> with values of 1, 2, 4, 8, 16, and 32. Any other value results in undefined behavior. This field is valid and applicable only when <code>USP</code> is set high.</p>
16	FB	RW	0	<p>Fixed Burst</p> <p>This bit defines if burst is used during burst transfer operations.</p> <p>Value Description</p> <p>0x0 The DMA bursts the entire length during burst transfers except for the last word, which is a single transfer.</p> <p>0x1 The DMA uses only single, or fixed bursts incremented by 4, 8, or 16 during normal bus transfers.</p>

Bit/Field	Name	Type	Reset	Description
15:14	PR	RW	0x0	<p>Priority Ratio</p> <p>These bits control the priority ratio in the weighted round-robin arbitration between the RX DMA and TX DMA. These bits are valid only when the <code>DA</code> bit in this register is clear. The priority ratio is RX:TX or TX:RX depending on whether the <code>TXPR</code> bit in this register is clear or set.</p> <p>Value Description</p> <p>0x0 The Priority Ratio is 1:1.</p> <p>0x1 The Priority Ratio is 2:1.</p> <p>0x2 The Priority Ratio is 3:1.</p> <p>0x3 The Priority Ratio is 4:1.</p>
13:8	PBL	RW	0x1	<p>Programmable Burst Length</p> <p>These bits indicate the maximum number of beats to be transferred in one DMA transaction.</p> <p>This is the maximum value that is used in a single block read or write. The DMA always attempts to burst as specified in <code>PBL</code> each time it starts a burst transfer on the bus. <code>PBL</code> can be programmed with permissible values of 1, 2, 4, 8, 16, and 32. Any other value results in undefined behavior. When <code>USP</code> is set high, this <code>PBL</code> value is applicable only for TX DMA transactions.</p> <p>If the number of beats to be transferred is more than 32, then perform the following steps:</p> <ol style="list-style-type: none"> 1. Set the <code>8xPBL</code> mode. 2. Set the <code>PBL</code> value. <p>For example, if the maximum number of beats to be transferred is 64, then first set <code>8xPBL</code> to 1 and then set <code>PBL</code> to 0x8.</p>
7	ATDS	RW	0x0	<p>Alternate Descriptor Size</p> <p>Value Description</p> <p>0 Descriptor size reverts back to four words</p> <p>1 Alternate descriptors, each eight words in length, are used.</p>
6:2	DSL	RW	0x0	<p>Descriptor Skip Length</p> <p>This bit specifies the number of words to skip between two unchained descriptors.</p> <p>The address skipping starts from the end of current descriptor to the start of next descriptor. When the <code>DSL</code> value is equal to zero, then the descriptor table is taken as contiguous by the DMA in Ring mode.</p>

Bit/Field	Name	Type	Reset	Description
1	DA	RW	0x0	<p>DMA Arbitration Scheme</p> <p>This bit specifies the arbitration scheme between the transmit and receive paths of the DMA channel.</p> <p>Value Description</p> <p>0 Weighted round-robin with RX:TX or TX:RX. The priority between the paths is according to the priority specified in the <code>PR</code> bit field and priority weights specified in the <code>TXPR</code> bit.</p> <p>1 Fixed priority. The transmit path has priority over receive path when the <code>TXPR</code> bit is set. Otherwise, receive path has priority over the transmit path.</p>
0	SWR	RW	0x1	<p>DMA Software Reset</p> <p>The software reset function is driven by this bit.</p> <p>The reset operation is completed only when all resets in all active clock domains are deasserted. It is essential that all the PHY input clocks are present for the software reset completion. The time of the software reset operation depends on the frequency of the slowest active clock.</p> <p>Value Description</p> <p>0 Reset is completed. A value of 0 should be read before reprogramming any MAC registers after a reset</p> <p>1 MAC DMA Controller resets the logic and all internal registers of the MAC. It is cleared automatically after the reset operation has completed in all of the MAC clock domains.</p>

Register 53: Ethernet MAC Transmit Poll Demand (EMACTXPOLL), offset 0xC04

The **MAC Transmit Poll Demand (EMACTXPOLL)** register enables the TX DMA to check whether or not the DMA owns the current descriptor. The Transmit Poll Demand command is given to wake up the TX DMA if it is in the suspend mode. The TX DMA can go into the SUSPEND mode because of an underflow error in a transmitted frame or the unavailability of descriptors owned by it. This Transmit Poll Demand command can be given at any time and the TX DMA resets this command when it again starts fetching the current descriptor from host memory.

Ethernet MAC Transmit Poll Demand (EMACTXPOLL)

Base 0x400E.C000

Offset 0xC04

Type WO, reset 0x0000.0000

	31	30	29	28	27	26	25	24	23	22	21	20	19	18	17	16
	TPD															
Type	WO	WO	WO	WO	WO	WO	WO	WO	WO	WO	WO	WO	WO	WO	WO	WO
Reset	0	0	0	0	0	0	0	0	0	0	0	0	0	0	0	0
	15	14	13	12	11	10	9	8	7	6	5	4	3	2	1	0
	TPD															
Type	WO	WO	WO	WO	WO	WO	WO	WO	WO	WO	WO	WO	WO	WO	WO	WO
Reset	0	0	0	0	0	0	0	0	0	0	0	0	0	0	0	0

Bit/Field	Name	Type	Reset	Description
31:0	TPD	WO	0x0	Transmit Poll Demand When these bits are written with any value, the DMA reads the current descriptor pointed to by the MAC Current Host Transmit Descriptor (EMACHOSTXDESC) register. If that descriptor is not available (owned by the Host), the transmission returns to the SUSPEND state and the \overline{TU} bit of the EMACDMARIS is asserted. If the descriptor is available, the transmission resumes.

Register 54: Ethernet MAC Receive Poll Demand (EMACRXPOLLD), offset 0xC08

The **Ethernet MAC Receive Poll Demand (EMACRXPOLLD)** register enables the RX DMA to check for new descriptors. This command is used to wake up the RX DMA from the SUSPEND state. The RX DMA can go into the SUSPEND state only because of the unavailability of descriptors it owns.

Ethernet MAC Receive Poll Demand (EMACRXPOLLD)

Base 0x400E.C000

Offset 0xC08

Type WO, reset 0x0000.0000

	31	30	29	28	27	26	25	24	23	22	21	20	19	18	17	16
	RPD															
Type	WO	WO	WO	WO	WO	WO	WO	WO	WO	WO	WO	WO	WO	WO	WO	WO
Reset	0	0	0	0	0	0	0	0	0	0	0	0	0	0	0	0
	15	14	13	12	11	10	9	8	7	6	5	4	3	2	1	0
	RPD															
Type	WO	WO	WO	WO	WO	WO	WO	WO	WO	WO	WO	WO	WO	WO	WO	WO
Reset	0	0	0	0	0	0	0	0	0	0	0	0	0	0	0	0

Bit/Field	Name	Type	Reset	Description
31:0	RPD	WO	0x0	<p>Receive Poll Demand</p> <p>When these bits are written with any value, the DMA reads the current descriptor pointed to by MAC Current Host Receive Descriptor (EMACHOSRXDESC) register. If that descriptor is not available (owned by the Host), the reception returns to the SUSPEND state and the RU bit of EMACDMARIS is not asserted. If the descriptor is available, the RX DMA returns to the active state.</p>

Register 55: Ethernet MAC Receive Descriptor List Address (EMACRXDLADDR), offset 0xC0C

The **Ethernet MAC Receive Descriptor List Address (EMACRXDLADDR)** register points to the start of the Receive Descriptor List. The descriptor lists reside in the host's physical memory space and must be word-aligned. The DMA internally converts it to a 32-bit aligned address by making the two least significant bits zero. Writing to this register is permitted only when the DMA receive transaction has stopped ($SR = 0$ in the **MAC DMA Operation Mode (EMACDMAOPMODE)** register). When stopped, this register must be written with a new descriptor list address before the receive Start command is given. When you set the SR bit to 1, the DMA takes the newly programmed descriptor base address. If this register is not changed when the SR bit is set to 0, then the DMA uses the already existing descriptor address.

Ethernet MAC Receive Descriptor List Address (EMACRXDLADDR)

Base 0x400E.C000

Offset 0xC0C

Type RW, reset 0x0000.0000

	31	30	29	28	27	26	25	24	23	22	21	20	19	18	17	16
	STRXLIST															
Type	RW	RW	RW	RW	RW	RW	RW	RW	RW	RW	RW	RW	RW	RW	RW	RW
Reset	0	0	0	0	0	0	0	0	0	0	0	0	0	0	0	0
	15	14	13	12	11	10	9	8	7	6	5	4	3	2	1	0
	STRXLIST														reserved	
Type	RW	RW	RW	RW	RW	RW	RW	RW	RW	RW	RW	RW	RW	RW	RO	RO
Reset	0	0	0	0	0	0	0	0	0	0	0	0	0	0	0	0

Bit/Field	Name	Type	Reset	Description
31:2	STRXLIST	RW	0x0	Start of Receive List This field contains the base address of the first descriptor in the Receive Descriptor list. The LSB bits[1:0] are ignored and internally taken as zero by the DMA. Therefore, bits[1:0] are read-only (RO).
1:0	reserved	RO	0x0	Software should not rely on the value of a reserved bit. To provide compatibility with future products, the value of a reserved bit should be preserved across a read-modify-write operation.

Register 56: Ethernet MAC Transmit Descriptor List Address (EMACTXDLADDR), offset 0xC10

The **MAC Transmit Descriptor List Address (EMACTXDLADDR)** register points to the start of the transmit descriptor list. The descriptor lists reside in the host's physical memory space and must be word-aligned.

This register can only be written when the DMA transmit has stopped ($ST = 0$ in the **MAC DMA Operation Mode (EMACDMAOPMODE)** register). When the ST bit is set, the DMA takes the uses the newly programmed descriptor base address.

If this register is not changed when the ST bit is set to 0, then the DMA uses the already existing descriptor address.

Ethernet MAC Transmit Descriptor List Address (EMACTXDLADDR)

Base 0x400E.C000
 Offset 0xC10
 Type RW, reset 0x0000.0000

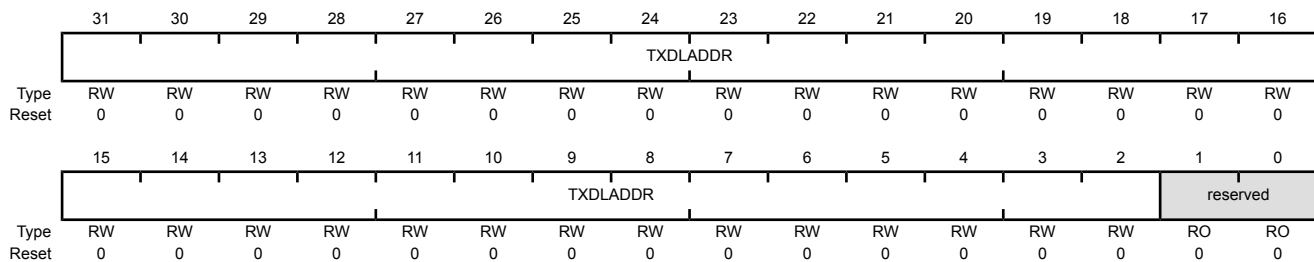

Bit/Field	Name	Type	Reset	Description
31:2	TXDLADDR	RW	0x0	Start of Transmit List Base Address This field contains the base address of the first descriptor in the transmit descriptor list. The LSB bits (1:0) for 32-bit bus width are ignored and are internally taken as all-zero by the DMA. Therefore, these LSB bits are read-only (RO).
1:0	reserved	RO	0x0	Software should not rely on the value of a reserved bit. To provide compatibility with future products, the value of a reserved bit should be preserved across a read-modify-write operation.

Register 57: Ethernet MAC DMA Interrupt Status (EMACDMARIS), offset 0xC14

The **MAC DMA Interrupt Status (EMACDMARIS)** register contains all status bits that the DMA reports to the host. The software driver reads this register during an interrupt service routine or polling. Most of the fields in this register cause the host to be interrupted. The bits of this register are not cleared when read. Writing a 1 to any bit in the lower half-word of this register clears the bit and writing a 0 has no effect. Status bits [16:0] can be masked by enabling the appropriate mask in the **MAC DMA Interrupt Mask Register (EMACDMAIM)** register.

Ethernet MAC DMA Interrupt Status (EMACDMARIS)

Base 0x400E.C000

Offset 0xC14

Type RW, reset 0x0000.0000

	31	30	29	28	27	26	25	24	23	22	21	20	19	18	17	16
	reserved		TT	PMT	MMC	reserved	AE		TS		RS		NIS			
Type	RO	RO	RO	RO	RO	RO	RO	RO	RO	RO	RO	RO	RO	RO	RO	RW1C
Reset	0	0	0	0	0	0	0	0	0	0	0	0	0	0	0	0
	15	14	13	12	11	10	9	8	7	6	5	4	3	2	1	0
	AIS	ERI	FBI	reserved	ETI	RWT	RPS	RU	RI	UNF	OVF	TJT	TU	TPS	TI	
Type	RW1C	RW1C	RW1C	RO	RO	RW1C	RW1C	RW1C	RW1C	RW1C	RW1C	RW1C	RW1C	RW1C	RW1C	RW1C
Reset	0	0	0	0	0	0	0	0	0	0	0	0	0	0	0	0

Bit/Field	Name	Type	Reset	Description				
31:30	reserved	RO	0x0	Software should not rely on the value of a reserved bit. To provide compatibility with future products, the value of a reserved bit should be preserved across a read-modify-write operation.				
29	TT	RO	0x0	<p>Timestamp Trigger Interrupt Status</p> <p>Software can read the Ethernet MAC Timestamp Status (EMACTIMSTAT) register for the exact cause of interrupt and clear its source to reset this bit to 0. When this bit is 1, the interrupt signal from the MAC subsystem is high.</p> <p>Value Description</p> <table border="0"> <tr> <td>0</td> <td>No Timestamp interrupt has occurred.</td> </tr> <tr> <td>1</td> <td>An interrupt event in the Timestamp module has occurred.</td> </tr> </table>	0	No Timestamp interrupt has occurred.	1	An interrupt event in the Timestamp module has occurred.
0	No Timestamp interrupt has occurred.							
1	An interrupt event in the Timestamp module has occurred.							
28	PMT	RO	0x0	<p>MAC PMT Interrupt Status</p> <p>Software can read the PMT Control and Status (EMACPMTCTLSTAT) register for the exact cause of the interrupt and clear its source to reset this bit to 0. When this bit is 1, the interrupt signal from the MAC subsystem is high.</p> <p>Value Description</p> <table border="0"> <tr> <td>0</td> <td>No PMT interrupt has occurred.</td> </tr> <tr> <td>1</td> <td>An interrupt event in the PMT module has occurred.</td> </tr> </table>	0	No PMT interrupt has occurred.	1	An interrupt event in the PMT module has occurred.
0	No PMT interrupt has occurred.							
1	An interrupt event in the PMT module has occurred.							

Bit/Field	Name	Type	Reset	Description
27	MMC	RO	0x0	<p>MAC MMC Interrupt</p> <p>This bit reflects an interrupt event in the MMC module. Software must read the corresponding EMACMMCTXRIS/EMACMMCRXRIS register to determine the cause of the interrupt and then clear its source to reset this bit to 0.</p> <p>Value Description</p> <p>0 No MMC interrupt has occurred.</p> <p>1 An interrupt in the MMC module has occurred.</p>
26	reserved	RO	0	Software should not rely on the value of a reserved bit. To provide compatibility with future products, the value of a reserved bit should be preserved across a read-modify-write operation.
25:23	AE	RO	0x0	<p>Access Error</p> <p>This field indicates the type of error that caused a bus error, for example, error response on the internal bus interface. This field is valid only when bit[13] (FBI) is set. This field does not generate an interrupt.</p> <p>Value Description</p> <p>0x0 Error during RX DMA Write Data Transfer</p> <p>0x1-0x2 reserved</p> <p>0x3 Error during TX DMA Read Data Transfer</p> <p>0x4 Error during RX DMA Descriptor Write Access</p> <p>0x5 Error during TX DMA Descriptor Write Access</p> <p>0x6 Error during RX DMA Descriptor Read Access</p> <p>0x7 Error during TX DMA Descriptor Read Access</p>
22:20	TS	RO	0x0	<p>Transmit Process State</p> <p>This field indicates the Transmit DMA state. This field does not generate an interrupt.</p> <p>Value Description</p> <p>0x0 Stopped; Reset or Stop transmit command processed</p> <p>0x1 Running; Fetching transmit transfer descriptor</p> <p>0x2 Running; Waiting for status</p> <p>0x3 Running; Reading data from host memory buffer and queuing it to transmit buffer (TX FIFO)</p> <p>0x4 Writing Timestamp</p> <p>0x5 reserved</p> <p>0x6 Suspended; Transmit descriptor unavailable or transmit buffer underflow</p> <p>0x7 Running; Closing transmit descriptor</p>

Bit/Field	Name	Type	Reset	Description
19:17	RS	RO	0x0	<p>Received Process State</p> <p>This field indicates the Receive DMA state. This field does not generate an interrupt.</p> <p>Value Description</p> <p>0x0 Stopped: Reset or stop receive command issued</p> <p>0x1 Running: Fetching receive transfer descriptor</p> <p>0x2 reserved</p> <p>0x3 Running: Waiting for receive packet</p> <p>0x4 Suspended: Receive descriptor unavailable</p> <p>0x5 Running: Closing receive descriptor</p> <p>0x6 Writing Timestamp</p> <p>0x7 Running: Transferring the receive packet data from receive buffer to host memory</p>
16	NIS	RW1C	0x0	<p>Normal Interrupt Summary</p> <p>Normal Interrupt Summary bit value is the logical OR of the following when the corresponding interrupt bits are enabled in EMACDMAIM register:</p> <ul style="list-style-type: none"> ■ EMACDMARIS register, bit [0]: Transmit Interrupt ■ EMACDMARIS register, bit[2]: Transmit Buffer Unavailable ■ EMACDMARIS register, bit[6]: Receive Interrupt ■ EMACDMARIS register, bit[14]: Early Receive Interrupt <p>Only unmasked bits (interrupts for which interrupt enable is set in the EMACDMAIM register) affect the Normal Interrupt Summary bit.</p> <p>This is a sticky bit and must be cleared (by writing 1 to this bit) each time a corresponding bit, which causes NIS to be set, is cleared.</p>

Bit/Field	Name	Type	Reset	Description						
15	AIS	RW1C	0x0	<p>Abnormal Interrupt Summary</p> <p>Abnormal Interrupt Summary bit value is the logical OR of the following when the corresponding interrupt bits are enabled in the EMACDMAIM register:</p> <ul style="list-style-type: none"> ■ EMACDMARIS register, bit[1]: Transmit Process Stopped ■ EMACDMARIS register, bit[3]: Transmit Jabber Timeout ■ EMACDMARIS register, bit[4]: Receive FIFO Overflow ■ EMACDMARIS register, bit[5]: Transmit Underflow ■ EMACDMARIS register, bit[7]: Receive Buffer Unavailable ■ EMACDMARIS register, bit[8]: Receive Process Stopped ■ EMACDMARIS register, bit[9]: Receive Watchdog Timeout ■ EMACDMARIS register, bit[10]: Early Transmit Interrupt ■ EMACDMARIS register, bit[13]: Fatal Bus Error <p>Only unmasked bits affect the Abnormal Interrupt Summary bit. This bit must be cleared each time a corresponding bit, which causes AIS to be set, is cleared.</p>						
14	ERI	RW1C	0x0	<p>Early Receive Interrupt</p> <table border="0"> <thead> <tr> <th>Value</th> <th>Description</th> </tr> </thead> <tbody> <tr> <td>0</td> <td>No early receive event has occurred.</td> </tr> <tr> <td>1</td> <td>The DMA has filled the first data buffer of the packet. This bit is cleared when software writes a 1 to this bit or if bit[6] (RI) of this register is set.</td> </tr> </tbody> </table>	Value	Description	0	No early receive event has occurred.	1	The DMA has filled the first data buffer of the packet. This bit is cleared when software writes a 1 to this bit or if bit[6] (RI) of this register is set.
Value	Description									
0	No early receive event has occurred.									
1	The DMA has filled the first data buffer of the packet. This bit is cleared when software writes a 1 to this bit or if bit[6] (RI) of this register is set.									
13	FBI	RW1C	0x0	<p>Fatal Bus Error Interrupt</p> <table border="0"> <thead> <tr> <th>Value</th> <th>Description</th> </tr> </thead> <tbody> <tr> <td>0</td> <td>No bus error has occurred.</td> </tr> <tr> <td>1</td> <td>A bus error has occurred, as described in the Error Bit field (EB[25:23]). When this bit is set, the corresponding DMA engine disables all of its bus accesses. This bit is cleared by writing a 1 to it.</td> </tr> </tbody> </table>	Value	Description	0	No bus error has occurred.	1	A bus error has occurred, as described in the Error Bit field (EB[25:23]). When this bit is set, the corresponding DMA engine disables all of its bus accesses. This bit is cleared by writing a 1 to it.
Value	Description									
0	No bus error has occurred.									
1	A bus error has occurred, as described in the Error Bit field (EB[25:23]). When this bit is set, the corresponding DMA engine disables all of its bus accesses. This bit is cleared by writing a 1 to it.									
12:11	reserved	RO	0x0	Software should not rely on the value of a reserved bit. To provide compatibility with future products, the value of a reserved bit should be preserved across a read-modify-write operation.						
10	ETI	RW1C	0x0	<p>Early Transmit Interrupt</p> <table border="0"> <thead> <tr> <th>Value</th> <th>Description</th> </tr> </thead> <tbody> <tr> <td>0</td> <td>No early transmit has occurred.</td> </tr> <tr> <td>1</td> <td>A frame to be transmitted has been fully transferred to the TX/RX Controller Transmit FIFO. This bit is cleared by writing a 1 to it.</td> </tr> </tbody> </table>	Value	Description	0	No early transmit has occurred.	1	A frame to be transmitted has been fully transferred to the TX/RX Controller Transmit FIFO. This bit is cleared by writing a 1 to it.
Value	Description									
0	No early transmit has occurred.									
1	A frame to be transmitted has been fully transferred to the TX/RX Controller Transmit FIFO. This bit is cleared by writing a 1 to it.									

Bit/Field	Name	Type	Reset	Description
9	RWT	RW1C	0x0	<p>Receive Watchdog Timeout</p> <p>Value Description</p> <p>0 No watchdog timeout event has occurred.</p> <p>1 Indicates a frame with length greater than 2,048 bytes is received (10, 240 when Jumbo Frame mode is enabled). This bit is cleared by writing a 1 to it.</p>
8	RPS	RW1C	0x0	<p>Receive Process Stopped</p> <p>Value Description</p> <p>0 No receive process stopped event has occurred.</p> <p>1 Indicates the receive process has entered the stopped state. This bit is cleared by writing a 1 to it.</p>
7	RU	RW1C	0x0	<p>Receive Buffer Unavailable</p> <p>Value Description</p> <p>0 No receive buffer unavailable event has occurred.</p> <p>1 Indicates the host owns the next descriptor in the receive list and the DMA cannot acquire it. The receive process is suspended. This bit is cleared by writing a 1 to it.</p> <p>To resume processing receive descriptors, the host should change the ownership of the descriptor and issue a Receive Poll Demand command. If no Receive Poll Demand is issued, the receive process resumes when the next recognized incoming frame is received. This bit is set only when the previous receive descriptor is owned by the DMA.</p>
6	RI	RW1C	0x0	<p>Receive Interrupt</p> <p>Value Description</p> <p>0 No frame reception complete event has occurred.</p> <p>1 A frame reception is complete. When reception is complete, bit[31] of RDES1 (disable interrupt on completion) is reset in the last descriptor, and the specific frame status information is updated in the descriptor. The reception remains in the Running state. This bit is cleared by writing a 1 to it.</p>
5	UNF	RW1C	0x0	<p>Transmit Underflow</p> <p>Value Description</p> <p>0 No transmit underflow event has occurred.</p> <p>1 Indicates the Transmit Buffer had an Underflow during frame transmission. Transmission is suspended and an Underflow Error TDES0[1] is set. This bit is cleared by writing a 1 to it.</p>

Bit/Field	Name	Type	Reset	Description
4	OVF	RW1C	0x0	<p>Receive Overflow</p> <p>Value Description</p> <p>0 No receive overflow event has occurred.</p> <p>1 The receive buffer had an overflow during frame reception. If the partial frame is transferred to the application, the overflow status is set in RDES0[11]. This bit is cleared by writing a 1 to it.</p>
3	TJT	RW1C	0x0	<p>Transmit Jabber Timeout</p> <p>Value Description</p> <p>0 No transmit jabber timeout event has occurred.</p> <p>1 The Transmit Jabber Timer expired, which happens when the frame size exceeds 2,048 (10,240 bytes when Jumbo frame is enabled). When the Jabber Timeout occurs, the transmission process is aborted and placed in the Stopped state. This causes the Transmit Jabber Timeout TDES0[14] flag to assert. This bit is cleared by writing a 1 to it.</p>
2	TU	RW1C	0x0	<p>Transmit Buffer Unavailable</p> <p>Value Description</p> <p>0 No transmit buffer unavailable event has occurred.</p> <p>1 Indicates the host owns the next descriptor in the transmit list and the DMA cannot acquire it. Transmission is suspended. The transmit process state bits (TS[22:20]) explain the transmit process state transitions. This bit is cleared by writing a 1 to it.</p> <p>To resume processing Transmit descriptors, the host should change the ownership of the descriptor by setting TDES0[31] and then issue a Transmit Poll Demand command.</p>
1	TPS	RW1C	0x0	<p>Transmit Process Stopped</p> <p>Value Description</p> <p>0 Interrupt is inactive.</p> <p>1 Indicates transmission is stopped.</p>
0	TI	RW1C	0x0	<p>Transmit Interrupt</p> <p>This bit indicates that frame transmission is complete. When transmission is complete, the Bit 31 (Interrupt on Completion) of TDES1 is reset in the first descriptor, and the specific frame status information is updated in the descriptor.</p> <p>Value Description</p> <p>0 Frame transmission completion event has not occurred.</p> <p>1 Frame transmission is complete. This bit is cleared by writing a 1 to it.</p>

Register 58: Ethernet MAC DMA Operation Mode (EMACDMAOPMODE), offset 0xC18

The **MAC DMA Operation Mode (EMACDMAOPMODE)** register establishes the Transmit and Receive operating modes and commands. This register should be the last register to be written as part of the DMA initialization.

Ethernet MAC DMA Operation Mode (EMACDMAOPMODE)

Base 0x400E.C000

Offset 0xC18

Type RW, reset 0x0000.0000

	31	30	29	28	27	26	25	24	23	22	21	20	19	18	17	16
	reserved				DT	RSF	DFF	reserved			TSF	FTF	reserved			TTC
Type	RO	RO	RO	RO	RO	RW	RW	RW	RO	RO	RW	RW	RO	RO	RO	RW
Reset	0	0	0	0	0	0	0	0	0	0	0	0	0	0	0	0
	15	14	13	12	11	10	9	8	7	6	5	4	3	2	1	0
	TTC		ST	reserved				FEF	FUF	DGF	RTC		OSF	SR	reserved	
Type	RW	RW	RW	RO	RO	RO	RO	RO	RW	RW	RW	RW	RW	RW	RW	RO
Reset	0	0	0	0	0	0	0	0	0	0	0	0	0	0	0	0

Bit/Field	Name	Type	Reset	Description
31:27	reserved	RO	0x0	Software should not rely on the value of a reserved bit. To provide compatibility with future products, the value of a reserved bit should be preserved across a read-modify-write operation.
26	DT	RW	0x0	Disable Dropping of TCP/IP Checksum Error Frames
				Value Description 0 All error frames are dropped if the FEF bit is reset. 1 The MAC does not drop the frames which only have errors detected by the Receive Checksum Offload engine. Such frames do not have any errors (including FCS error) in the Ethernet frame received by the MAC but have errors only in the encapsulated payload.
25	RSF	RW	0x0	Receive Store and Forward
				Value Description 0 The RX FIFO operates in the cut-through mode, subject to the threshold specified by the RTC bits. 1 The TX/RX Controller reads a frame from the RX FIFO only after the complete frame has been written to it, ignoring the RTC bits.
24	DFF	RW	0x0	Disable Flushing of Received Frames
				Value Description 0 RX DMA flushes frames based on receive descriptors or buffers. 1 The RX DMA does not flush any frames because of the unavailability of receive descriptors or buffers.

Bit/Field	Name	Type	Reset	Description
23:22	reserved	RO	0x0	Software should not rely on the value of a reserved bit. To provide compatibility with future products, the value of a reserved bit should be preserved across a read-modify-write operation.
21	TSF	RW	0x0	<p>Transmit Store and Forward</p> <p>Value Description</p> <p>0 Transmission starts according to TTC bit field.</p> <p>1 Transmission starts when a full frame resides in the TX/RX Controller Transmit FIFO. Additionally, the TTC values specified in TTC bits[16:14] are ignored. This bit should be changed only when the transmission is stopped.</p>
20	FTF	RW	0x0	<p>Flush Transmit FIFO</p> <p>This bit is cleared internally when the flushing operation is completed. This register should not be written to until the FTF bit is cleared. The data which has already been accepted by the MAC transmitter is not flushed. It is scheduled for transmission and results in underflow and runt frame transmission.</p> <p>Value Description</p> <p>0 This bit indicated normal operation or that the flushing operation has completed.</p> <p>1 The transmit FIFO controller logic is reset to its default values and thus all data in the TX FIFO is lost or flushed. This bit is cleared internally when the flushing operation is complete.</p> <p>Note: The flush operation is complete only when the TX FIFO is emptied of its contents and all the pending Transmit Status of the transmitted frames are accepted by the host.</p>
19:17	reserved	RO	0x0	Software should not rely on the value of a reserved bit. To provide compatibility with future products, the value of a reserved bit should be preserved across a read-modify-write operation.
16:14	TTC	RW	0x0	<p>Transmit Threshold Control</p> <p>These bits control the threshold level of the TX/RX Controller Transmit FIFO. Transmission starts when the frame size within the TX/RX Controller Transmit FIFO is larger than the threshold. In addition, full frames with a length less than the threshold are also transmitted. These bits are used only when Bit 21 (TSF) is reset.</p> <p>Value Description</p> <p>0x0 64 bytes</p> <p>0x1 128 bytes</p> <p>0x2 192 bytes</p> <p>0x3 256 bytes</p> <p>0x4 40 bytes</p> <p>0x5 32 bytes</p> <p>0x6 24 bytes</p> <p>0x7 16 bytes</p>

Bit/Field	Name	Type	Reset	Description				
13	ST	RW	0x0	<p>Start or Stop Transmission Command</p> <p>When this bit is set, transmission is placed in the running state. The DMA attempts to acquire the descriptor from the Transmit Descriptor List. Descriptor acquisition is attempted from the current position in the list, which is the Transmit List Base Address set by Transmit Descriptor List Address (EMACTXDLADDR) register, or from the position retained when transmission was stopped previously.</p> <p>If the DMA does not own the current descriptor, transmission enters the suspended state and bit[2] (Transmit Buffer Unavailable, TU) of the MAC DMA Raw Interrupt Status Register (EMACDMARIS) is set. The Start Transmission command is effective only when transmission is stopped. If the command is issued before setting EMACTXDLADDR, then the DMA behavior is unpredictable.</p> <p>When this bit is cleared, the transmission process is placed in the Stopped state after completing the transmission of the current frame. The Next Descriptor position in the Transmit List is saved, and it becomes the current position when transmission is restarted. To change the list address, you need to program EMACTXDLADDR with a new value when this bit is reset. The new value is considered when this bit is set again. The stop transmission command is effective only when the transmission of the current frame is complete or the transmission is in the Suspended state.</p> <p>Value Description</p> <table border="0"> <tr> <td>0</td> <td>Transmission process is placed in the stopped state after completing the transmission of the current frame. The Next Descriptor position in the Transmit List is saved, and it becomes the current position when transmission is restarted.</td> </tr> <tr> <td>1</td> <td>Transmission is placed in the running state, and the DMA checks the transmit list at the current position for a frame to be transmitted.</td> </tr> </table>	0	Transmission process is placed in the stopped state after completing the transmission of the current frame. The Next Descriptor position in the Transmit List is saved, and it becomes the current position when transmission is restarted.	1	Transmission is placed in the running state, and the DMA checks the transmit list at the current position for a frame to be transmitted.
0	Transmission process is placed in the stopped state after completing the transmission of the current frame. The Next Descriptor position in the Transmit List is saved, and it becomes the current position when transmission is restarted.							
1	Transmission is placed in the running state, and the DMA checks the transmit list at the current position for a frame to be transmitted.							
12:8	reserved	RO	0x0	Software should not rely on the value of a reserved bit. To provide compatibility with future products, the value of a reserved bit should be preserved across a read-modify-write operation.				
7	FEF	RW	0x0	<p>Forward Error Frames</p> <p>When this bit is reset, the RX FIFO drops frames with error status (CRC error, collision error, MII_ER, giant frame, watchdog timeout, or overflow). However, if the start byte (write) pointer of a frame is already transferred to the RX controller side (in Threshold mode), then the frame is not dropped.</p> <p>When the FEF bit is set, all frames except runt error frames are forwarded to the DMA. If Bit 25, Receive Store and Forward (RSF), is set and the RX FIFO overflows when a partial frame is written, then the frame is dropped irrespective of the FEF bit setting. However, if the RSF is reset and the RX FIFO overflows when a partial frame is written, then a partial frame may be forwarded to the DMA.</p> <p>Value Description</p> <table border="0"> <tr> <td>0</td> <td>The Receive FIFO drops frames with error status</td> </tr> <tr> <td>1</td> <td>All frames except runt error frames are forwarded to the DMA.</td> </tr> </table>	0	The Receive FIFO drops frames with error status	1	All frames except runt error frames are forwarded to the DMA.
0	The Receive FIFO drops frames with error status							
1	All frames except runt error frames are forwarded to the DMA.							

Bit/Field	Name	Type	Reset	Description
6	FUF	RW	0x0	<p>Forward Undersized Good Frames</p> <p>Value Description</p> <p>0 The Receive FIFO drops all frames of less than 64 bytes, unless a frame is already transferred because of the lower value of Receive Threshold (RTC) bit field (for example, RTC = 0x1).</p> <p>1 The Receive FIFO forwards undersized frames (frames with no Error and length less than 64 bytes) including pad-bytes and CRC.</p>
5	DGF	RW	0x0	<p>Drop Giant Frame Enable</p> <p>Value Description</p> <p>0 The MAC does not drop the giant frames in the RX FIFO.</p> <p>1 The MAC drops received frames larger than the computed giant frame limit in the RX FIFO.</p>
4:3	RTC	RW	0x0	<p>Receive Threshold Control</p> <p>These two bits control the threshold level of the RX FIFO. Transfer (request) to DMA starts when the frame size within the RX FIFO is larger than the threshold. In addition, full frames with length less than the threshold are transferred automatically.</p> <p>These bits are valid only when the RSF bit (bit 25) of the EMACDMAOPMODE is zero, and are ignored when the RSF bit is set to 1.</p> <p>Value Description</p> <p>0x0 64 bytes</p> <p>0x1 32 bytes</p> <p>0x2 96 bytes</p> <p>0x3 128 bytes</p>
2	OSF	RW	0x0	<p>Operate on Second Frame</p> <p>Value Description</p> <p>0 DMA processes frames normally.</p> <p>1 DMA processes second frame of the Transmit data even before the status for the first frame is obtained.</p>

Bit/Field	Name	Type	Reset	Description
1	SR	RW	0x0	<p>Start or Stop Receive</p> <p>When this bit is set, the Receive process is placed in the Running state. The DMA attempts to acquire the descriptor from the Receive list and processes the incoming frames. The descriptor acquisition is attempted from the current position in the list, which is the address set by the Receive Descriptor List Address Register (EMACRXDLADDR) or the position retained when the Receive process was previously stopped. If the DMA does not own the descriptor, reception is suspended and Bit 7 (Receive Buffer Unavailable, RU) of the MAC DMA Interrupt Status Register (EMACDMARIS) is set. The Start Receive command is effective only when the reception has stopped. If the command is issued before setting EMACRXDLADDR, the DMA behavior is unpredictable.</p> <p>When this bit is cleared, the receive DMA operation is stopped after the transfer of the current frame. The next descriptor position in the Receive list is saved and becomes the current position after the Receive process is restarted. The Stop Receive command is effective only when the Receive process is in either the Running (waiting for receive packet) or in the Suspended state.</p> <p>Value Description</p> <p>0 The receive DMA operation is stopped after the transfer of the current frame</p> <p>1 The Receive process is placed in the Running state.</p>
0	reserved	RO	0x0	Software should not rely on the value of a reserved bit. To provide compatibility with future products, the value of a reserved bit should be preserved across a read-modify-write operation.

Register 59: Ethernet MAC DMA Interrupt Mask Register (EMACDMAIM), offset 0xC1C

The Interrupt Enable register enables the interrupts reported by the MAC DMA Interrupt Status Register (**EMACDMARIS**). Setting a bit to 0x1 enables a corresponding interrupt. After a hardware or software reset, all interrupts are disabled.

Ethernet MAC DMA Interrupt Mask Register (EMACDMAIM)

Base 0x400E.C000

Offset 0xC1C

Type RW, reset 0x0000.0000

	31	30	29	28	27	26	25	24	23	22	21	20	19	18	17	16
	reserved															NIE
Type	RO	RO	RO	RO	RO	RO	RO	RO	RO	RO	RO	RO	RO	RO	RO	RW
Reset	0	0	0	0	0	0	0	0	0	0	0	0	0	0	0	0
	15	14	13	12	11	10	9	8	7	6	5	4	3	2	1	0
	AIE	ERE	FBE	reserved	ETE	RWE	RSE	RUE	RIE	UNE	OVE	TJE	TUE	TSE	TIE	
Type	RW	RW	RW	RO	RO	RW	RW	RW	RW	RW	RW	RW	RW	RW	RW	RW
Reset	0	0	0	0	0	0	0	0	0	0	0	0	0	0	0	0

Bit/Field	Name	Type	Reset	Description
31:17	reserved	RO	0x0	Software should not rely on the value of a reserved bit. To provide compatibility with future products, the value of a reserved bit should be preserved across a read-modify-write operation.
16	NIE	RW	0x0	Normal Interrupt Summary Enable Value Description 0 Normal interrupt summary is masked. 1 Normal interrupt summary is enabled. This bit enables/masks the ERI , RI , TU , and TI bits in MAC DMA Interrupt Status Register (EMACDMARIS)
15	AIE	RW	0x0	Abnormal Interrupt Summary Enable Value Description 0 Abnormal interrupt summary is disabled. 1 Abnormal interrupt summary is enabled. This bit enables/masks the TPS , TJT , OVF , UNF , RU , RPS , RWT , ETI and FBI bits in MAC DMA Interrupt Status Register (EMACDMARIS)
14	ERE	RW	0x0	Early Receive Interrupt Enable Value Description 0 Early receive interrupt is disabled. 1 Early receive interrupt is enabled. Normal Interrupt Summary Enable (NIE , bit 16) must also be set to 0x1.

Bit/Field	Name	Type	Reset	Description
13	FBE	RW	0x0	<p>Fatal Bus Error Enable</p> <p>Value Description</p> <p>0 Fatal Bus Error Enable Interrupt is disabled.</p> <p>1 Fatal Bus Error Interrupt is enabled. Abnormal Interrupt Summary Enable (AIE, bit 15) must also be set to 0x1.</p>
12:11	reserved	RO	0x0	Software should not rely on the value of a reserved bit. To provide compatibility with future products, the value of a reserved bit should be preserved across a read-modify-write operation.
10	ETE	RW	0x0	<p>Early Transmit Interrupt Enable</p> <p>Value Description</p> <p>0 Early Transmit Interrupt is disabled.</p> <p>1 Early Transmit Interrupt is enabled. Abnormal Interrupt Summary Enable (AIE, bit 15) must also be set to 0x1.</p>
9	RWE	RW	0x0	<p>Receive Watchdog Timeout Enable</p> <p>Value Description</p> <p>0 The Receive Watchdog Timeout Interrupt is disabled.</p> <p>1 The Receive Watchdog Timeout Interrupt is enabled. Abnormal Interrupt Summary Enable (AIE, bit 15) must also be set to 0x1.</p>
8	RSE	RW	0x0	<p>Receive Stopped Enable</p> <p>Value Description</p> <p>0 Receive Stopped Interrupt is disabled.</p> <p>1 Receive Stopped Interrupt is enabled. Abnormal Interrupt Summary Enable (AIE, bit 15) must also be set to 0x1.</p>
7	RUE	RW	0x0	<p>Receive Buffer Unavailable Enable</p> <p>Value Description</p> <p>0 The Receive Buffer Unavailable Interrupt is disabled.</p> <p>1 The Receive Buffer Unavailable Interrupt is enabled. Abnormal Interrupt Summary Enable (AIE, bit 15) must also be set to 0x1.</p>
6	RIE	RW	0x0	<p>Receive Interrupt Enable</p> <p>Value Description</p> <p>0 The Receive Interrupt is disabled.</p> <p>1 The Receive Interrupt is enabled. Normal Interrupt Summary Enable (NIE, bit 15) must also be set to 0x1.</p>

Bit/Field	Name	Type	Reset	Description
5	UNE	RW	0x0	Underflow Interrupt Enable Value Description 0 Transmit Underflow Interrupt is disabled. 1 The Transmit Underflow Interrupt is enabled. Abnormal Interrupt Summary Enable (AIE, bit 15) must also be set to 0x1.
4	OVE	RW	0x0	Overflow Interrupt Enable Value Description 0 The Overflow Interrupt is disabled. 1 The Receive Overflow Interrupt is enabled. Abnormal Interrupt Summary Enable (AIE, bit 15) must also be set to 0x1.
3	TJE	RW	0x0	Transmit Jabber Timeout Enable Value Description 0 Transmit Jabber Timeout Interrupt is disabled. 1 Transmit Jabber Timeout Interrupt is enabled. Abnormal Interrupt Summary Enable (AIE, bit 15) must also be set to 0x1.
2	TUE	RW	0x0	Transmit Buffer Unavailable Enable Value Description 0 Transmit Buffer Unavailable Interrupt is disabled. 1 Transmit Buffer Unavailable Interrupt is enabled. Normal Interrupt Summary Enable (NIE, bit 15) must also be set to 0x1.
1	TSE	RW	0x0	Transmit Stopped Enable Value Description 0 Transmission Stopped Interrupt is disabled. 1 Transmission Stopped Interrupt is enabled. Abnormal Interrupt Summary Enable (AIE, bit 15) must also be set to 0x1.
0	TIE	RW	0x0	Transmit Interrupt Enable Value Description 0 Transmit Interrupt is disabled. 1 Transmit Interrupt is enabled. Normal Interrupt Summary Enable (NIE, bit 15) must also be set to 0x1.

Register 60: Ethernet MAC Missed Frame and Buffer Overflow Counter (EMACMFOBC), offset 0xC20

The DMA maintains two counters to track the number of frames missed during reception. This register reports the current value of the counters. The counter is used for diagnostic purposes. The MISFRMCNT field indicates missed frames because of the host buffer being unavailable. The OVFFRMCNT field indicates missed frames because of buffer overflow conditions (MTL and MAC) and runt frames (good frames of less than 64 bytes) dropped by the MTL.

Ethernet MAC Missed Frame and Buffer Overflow Counter (EMACMFOBC)

Base 0x400E.C000

Offset 0xC20

Type RO, reset 0x0000.0000

	31	30	29	28	27	26	25	24	23	22	21	20	19	18	17	16	
	reserved			OVFCNTOVF	OVFFRMCNT											MISCNTOVF	
Type	RO	RO	RO	RO	RO	RO	RO	RO	RO	RO	RO	RO	RO	RO	RO	RO	RO
Reset	0	0	0	0	0	0	0	0	0	0	0	0	0	0	0	0	0
	15	14	13	12	11	10	9	8	7	6	5	4	3	2	1	0	
	MISFRMCNT																
Type	RO	RO	RO	RO	RO	RO	RO	RO	RO	RO	RO	RO	RO	RO	RO	RO	RO
Reset	0	0	0	0	0	0	0	0	0	0	0	0	0	0	0	0	0

Bit/Field	Name	Type	Reset	Description
31:29	reserved	RO	0x0	Software should not rely on the value of a reserved bit. To provide compatibility with future products, the value of a reserved bit should be preserved across a read-modify-write operation.
28	OVFCNTOVF	RO	0	Overflow Bit for FIFO Overflow Counter This bit is set every time the overflow frame counter (bits [27:17]) overflows; that is, the RX FIFO overflows with the overflow frame counter at maximum value. In such a scenario, the overflow frame counter is reset to all zeros and this bit indicates the rollover happened.
27:17	OVFFRMCNT	RO	0x0	Overflow Frame Counter This field indicates the number of frames missed by the application. This counter is incremented each time the TX/RX Controller indicates overflow. This counter is cleared when the TX/RX Controller accepts data.
16	MISCNTOVF	RO	0x0	Overflow bit for Missed Frame Counter This bit is set every time the Missed Frame Counter (bits [15:0]) overflows; which means the DMA discards an incoming frame because of the Host Receive Buffer being unavailable with the missed frame counter at maximum value. In such a scenario, the Missed Frame Counter is reset to all zeros and this bit indicates that the rollover happened.
15:0	MISFRMCNT	RO	0x0	Missed Frame Counter This field indicates the number of frames missed by the controller because of the Host Receive Buffer being unavailable. This counter is incremented each time the DMA discards an incoming frame. This counter is cleared when the DMA accepts frames.

Register 61: Ethernet MAC Receive Interrupt Watchdog Timer (EMACRXINTWDT), offset 0xC24

This register, when written with non-zero value, enables the watchdog timer for the Receive Interrupt, RI (Bit 6), of the **EMACDMARIS** register at EMAC offset 0xC14.

Ethernet MAC Receive Interrupt Watchdog Timer (EMACRXINTWDT)

Base 0x400E.C000

Offset 0xC24

Type RW, reset 0x0000.0000

	31	30	29	28	27	26	25	24	23	22	21	20	19	18	17	16
	reserved															
Type	RO	RO	RO	RO	RO	RO	RO	RO	RO	RO	RO	RO	RO	RO	RO	RO
Reset	0	0	0	0	0	0	0	0	0	0	0	0	0	0	0	0
	15	14	13	12	11	10	9	8	7	6	5	4	3	2	1	0
	reserved								RIWT							
Type	RO	RO	RO	RO	RO	RO	RO	RO	RW	RW	RW	RW	RW	RW	RW	RW
Reset	0	0	0	0	0	0	0	0	0	0	0	0	0	0	0	0

Bit/Field	Name	Type	Reset	Description
31:8	reserved	RO	0x0	Software should not rely on the value of a reserved bit. To provide compatibility with future products, the value of a reserved bit should be preserved across a read-modify-write operation.
7:0	RIWT	RW	0x0	<p>Receive Interrupt Watchdog Timer Count</p> <p>This field indicates the period in which the receive counter expires. The value in this field is programmed by 256 to calculate the number of system clock periods the timer must count.</p> <p>Watchdog Timer Period = (RIWT * 256) system clocks.</p> <p>When the watchdog timer runs out, the RI bit is set and the timer is stopped.</p> <p>If the RDES[31] bit is clear, the watchdog timer is reset.</p>

Register 62: Ethernet MAC Current Host Transmit Descriptor (EMACHOSTXDESC), offset 0xC48

The **MAC Current Host Transmit Descriptor (EMACHOSTXDESC)** register points to the start address of the current Transmit Descriptor read by the DMA.

Ethernet MAC Current Host Transmit Descriptor (EMACHOSTXDESC)

Base 0x400E.C000

Offset 0xC48

Type R, reset 0x0000.0000

	31	30	29	28	27	26	25	24	23	22	21	20	19	18	17	16
	CURTXDESC															
Type	RO	RO	RO	RO	RO	RO	RO	RO	RO	RO	RO	RO	RO	RO	RO	RO
Reset	0	0	0	0	0	0	0	0	0	0	0	0	0	0	0	0
	15	14	13	12	11	10	9	8	7	6	5	4	3	2	1	0
	CURTXDESC															
Type	RO	RO	RO	RO	RO	RO	RO	RO	RO	RO	RO	RO	RO	RO	RO	RO
Reset	0	0	0	0	0	0	0	0	0	0	0	0	0	0	0	0

Bit/Field	Name	Type	Reset	Description
31:0	CURTXDESC	RO	0x0	Host Transmit Descriptor Address Pointer This register contains the start address of the current transmit descriptor read by the DMA. This register is cleared on reset. The pointer is updated by the DMA during operation.

Register 63: Ethernet MAC Current Host Receive Descriptor (EMACHOSRXDESC), offset 0xC4C

The **MAC Current Host Receive Descriptor (EMACHOSRXDESC)** register points to the start address of the current Receive Descriptor read by the DMA.

Ethernet MAC Current Host Receive Descriptor (EMACHOSRXDESC)

Base 0x400E.C000
 Offset 0xC4C
 Type RO, reset 0x0000.0000

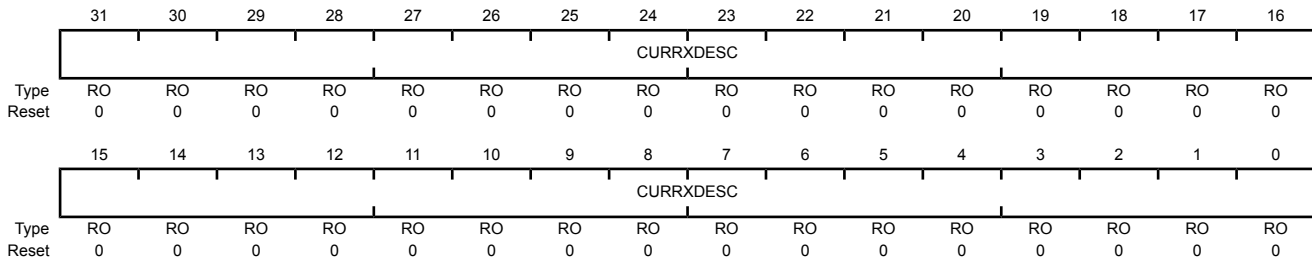

Bit/Field	Name	Type	Reset	Description
31:0	CURRXDESC	RO	0x0	Host Receive Descriptor Address Pointer This register contains the start address of the current receive descriptor read by the DMA. This register is cleared on reset. The pointer is updated by the DMA during operation.

Register 64: Ethernet MAC Current Host Transmit Buffer Address (EMACHOSTXBA), offset 0xC50

The **MAC Current Host Transmit Buffer Address (EMACHOSTXBA)** register points to the current Transmit Buffer Address being read by the DMA.

Ethernet MAC Current Host Transmit Buffer Address (EMACHOSTXBA)

Base 0x400E.C000

Offset 0xC50

Type R, reset 0x0000.0000

	31	30	29	28	27	26	25	24	23	22	21	20	19	18	17	16
	CURTXBUFA															
Type	RO	RO	RO	RO	RO	RO	RO	RO	RO	RO	RO	RO	RO	RO	RO	RO
Reset	0	0	0	0	0	0	0	0	0	0	0	0	0	0	0	0
	15	14	13	12	11	10	9	8	7	6	5	4	3	2	1	0
	CURTXBUFA															
Type	RO	RO	RO	RO	RO	RO	RO	RO	RO	RO	RO	RO	RO	RO	RO	RO
Reset	0	0	0	0	0	0	0	0	0	0	0	0	0	0	0	0

Bit/Field	Name	Type	Reset	Description
31:0	CURTXBUFA	RO	0x0	Host Transmit Buffer Address Pointer This register contains the current transmit buffer address being read by the DMA. This register is cleared on reset. The pointer is updated by the DMA during operation.

Register 65: Ethernet MAC Current Host Receive Buffer Address (EMACHOSRXBA), offset 0xC54

The **MAC Current Host Receive Buffer Address (EMACHOSRXBA)** register points to the current receive buffer address being read by the DMA.

Ethernet MAC Current Host Receive Buffer Address (EMACHOSRXBA)

Base 0x400E.C000

Offset 0xC54

Type R, reset 0x0000.0000

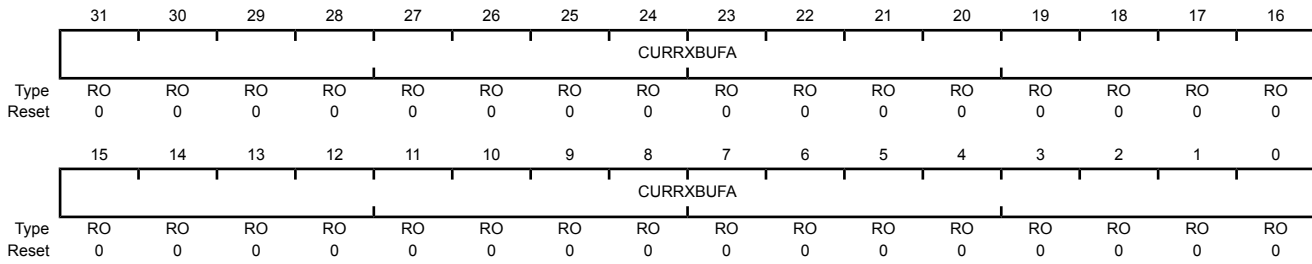

Bit/Field	Name	Type	Reset	Description
31:0	CURRXBUFA	RO	0x0	Host Receive Buffer Address Pointer This register contains the current receive buffer address being read by the DMA. This register is cleared on reset. The pointer is updated by the DMA during operation.

Register 66: Ethernet MAC Peripheral Property Register (EMACPP), offset 0xFC0

This register defines the Ethernet MAC and PHY type used.

Ethernet MAC Peripheral Property Register (EMACPP)

Base 0x400E.C000

Offset 0xFC0

Type RO, reset 0x0000.0103

	31	30	29	28	27	26	25	24	23	22	21	20	19	18	17	16
	reserved															
Type	RO	RO	RO	RO	RO	RO	RO	RO	RO	RO	RO	RO	RO	RO	RO	RO
Reset	0	0	0	0	0	0	0	0	0	0	0	0	0	0	0	0
	15	14	13	12	11	10	9	8	7	6	5	4	3	2	1	0
	reserved				MACTYPE				reserved				PHYTYPE			
Type	RO	RO	RO	RO	RO	RO	RO	RO	RO	RO	RO	RO	RO	RO	RO	RO
Reset	0	0	0	0	0	0	0	1	0	0	0	0	0	0	1	1

Bit/Field	Name	Type	Reset	Description												
31:11	reserved	RO	0x0	Software should not rely on the value of a reserved bit. To provide compatibility with future products, the value of a reserved bit should be preserved across a read-modify-write operation.												
10:8	MACTYPE	RO	0x1	Ethernet MAC Type <table border="0"> <tr> <td>Value</td> <td>Description</td> </tr> <tr> <td>0x0</td> <td>Stellaris® LM3S-class MAC.</td> </tr> <tr> <td>0x1</td> <td>Tiva™ TM4C129x-class MAC.</td> </tr> <tr> <td>0x2-0x7</td> <td>Reserved</td> </tr> </table>	Value	Description	0x0	Stellaris® LM3S-class MAC.	0x1	Tiva™ TM4C129x-class MAC.	0x2-0x7	Reserved				
Value	Description															
0x0	Stellaris® LM3S-class MAC.															
0x1	Tiva™ TM4C129x-class MAC.															
0x2-0x7	Reserved															
7:3	reserved	RO	0	Software should not rely on the value of a reserved bit. To provide compatibility with future products, the value of a reserved bit should be preserved across a read-modify-write operation.												
2:0	PHYTYPE	RO	0x3	Ethernet PHY Type This field specifies the type of PHY provided. <table border="0"> <tr> <td>Value</td> <td>Description</td> </tr> <tr> <td>0x0</td> <td>No PHY</td> </tr> <tr> <td>0x1</td> <td>Fury class PHY</td> </tr> <tr> <td>0x2</td> <td>Tempest/Firestorm class PHY</td> </tr> <tr> <td>0x3</td> <td>Snowflake class PHY</td> </tr> <tr> <td>0x4-0x7</td> <td>Reserved</td> </tr> </table>	Value	Description	0x0	No PHY	0x1	Fury class PHY	0x2	Tempest/Firestorm class PHY	0x3	Snowflake class PHY	0x4-0x7	Reserved
Value	Description															
0x0	No PHY															
0x1	Fury class PHY															
0x2	Tempest/Firestorm class PHY															
0x3	Snowflake class PHY															
0x4-0x7	Reserved															

Register 67: Ethernet MAC Peripheral Configuration Register (EMACPC), offset 0xFC4

The **Ethernet MAC Peripheral Configuration Register (EMACPC)** register configures the MAC and PHY reset and interface parameters.

Ethernet MAC Peripheral Configuration Register (EMACPC)

Base 0x400E.C000

Offset 0xFC4

Type RW, reset 0x0080.040E

	31	30	29	28	27	26	25	24	23	22	21	20	19	18	17	16
	PHYEXT	PINTFS			reserved		DIGRESTART	NIBDETDIS	RXERIDLE	ISOMILL	LRR	TDRRUN	FASTLDMODE			
Type	RW	RW	RW	RW	RO	RO	RW	RO	RW	RW	RW	RW	RW	RW	RW	RW
Reset	0	0	0	0	0	0	0	0	1	0	0	0	0	0	0	0
	15	14	13	12	11	10	9	8	7	6	5	4	3	2	1	0
	FASTLDMODE	POLSWAP	MDISWAP	RBSTMDIX	FASTMDIX	MDIXEN	FASTRXDV	FASTLUPD	EXTFD	FASTANEN	FASTANSEL	ANEN	ANMODE		PHYHOLD	
Type	RW	RW	RW	RW	RO	RW	RW	RW	RW	RW	RW	RW	RW	RW	RW	RW
Reset	0	0	0	0	0	1	0	0	0	0	0	0	1	0	3	0

Bit/Field	Name	Type	Reset	Description
31	PHYEXT	RW	0	PHY Select This bit is used to select whether the internal or an external PHY is used. Value Description 0 Internal PHY 1 External PHY
30:28	PINTFS	RW	0	Ethernet Interface Select This field selects the PHY interface used by the MAC. This input is sampled during reset and an update to this register field must result in the MAC undergoing a reset event. This field has the following encoded values: Value Description 0x0 MII (default) Used for internal PHY or external PHY connected via MII. 0x1-0x3 reserved 0x4 RMII: Used for external PHY connected via RMII. 0x5-0x7 reserved
27:26	reserved	RO	0x0	Software should not rely on the value of a reserved bit. To provide compatibility with future products, the value of a reserved bit should be preserved across a read-modify-write operation.
25	DIGRESTART	RW	0	PHY Soft Restart This bit allows the user to restart the PHY. Asserting this bit causes the PHY logic and internal register to reset to initial conditions. This bit does not affect the configuration bits provided by the EMACPC register, which are stored in the PHY following a chip reset. To initiate the soft reset to the PHY, this bit must be written to a 1 and written again to a 0.

Bit/Field	Name	Type	Reset	Description
24	NIBDETDIS	RO	0	Odd Nibble TXER Detection Disable This bit is sampled on the deassertion of the PHY reset signal and is used as the default for the <code>ODDNDETDIS</code> bit of the Ethernet PHY Configuration 2 (EPHYCFG2) register, PHY offset 0x00A.
23	RXERIDLE	RW	1	RXER Detection During Idle This bit is sampled on the deassertion of the PHY reset signal and is used as the default for the <code>RXERRIDLE</code> bit of the Ethernet PHY Configuration 2 (EPHYCFG2) register, PHY offset 0x00A.
22	ISOMIILL	RW	0	Isolate MII in Link Loss This bit is sampled on the deassertion of the PHY reset signal and is used as the default for the <code>ISOMIILL</code> bit of the Ethernet PHY Configuration 2 (EPHYCFG2) register, PHY offset 0x00A.
21	LRR	RW	0	Link Loss Recovery This bit is sampled on the deassertion of the PHY reset signal and is used as the default for the <code>LLR</code> bit of the Ethernet PHY Configuration 1 (EPHYCFG1) register, PHY offset 0x009.
20	TDRRUN	RW	0	TDR Auto Run This bit is sampled on the deassertion of the PHY reset signal and is used as the default for the <code>TDRAR</code> bit of the Ethernet PHY Configuration 1 (EPHYCFG1) register, PHY offset 0x009.
19:15	FASTLDMODE	RW	0	Fast Link Down Mode These bits are sampled on the deassertion of the PHY reset signal and are used as the default for the <code>FLDWNM</code> bit field of the Ethernet PHY Configuration 3 (EPHYCFG3) register, PHY offset 0x00B.
14	POLSWAP	RW	0	Polarity Swap This bit is sampled on the deassertion of the PHY reset signal and is used as the default for the <code>POLSWAP</code> bit of the Ethernet PHY Configuration 3 (EPHYCFG3) register PHY offset 0x00B.
13	MDISWAP	RW	0	MDI Swap This bit is sampled on the deassertion of the PHY reset signal and is used as the default for the <code>MDIMDIXS</code> bit of the Ethernet PHY Configuration 3 (EPHYCFG3) register, PHY offset 0x00B.
12	RBSTMDIX	RW	0	Robust Auto MDI-X This bit is sampled on the deassertion of the PHY reset signal and is used as the default for the <code>RAMDIX</code> bit of the Ethernet PHY Configuration 1 (EPHYCFG1) register, PHY offset 0x009.
11	FASTMDIX	RO	0	Fast Auto MDI-X This bit is sampled on the deassertion of the PHY reset signal and is used as the default for the <code>FAMDIX</code> bit of the Ethernet PHY Configuration 1 (EPHYCFG1) register, PHY offset 0x009.

Bit/Field	Name	Type	Reset	Description
10	MDIXEN	RW	1	<p>MDIX Enable</p> <p>This bit is sampled on the deassertion of the PHY reset signal and is used to determine whether automatic MDI/MDIX crossover is enabled.</p> <p>Value Description</p> <p>0 Disable automatic cross-over.</p> <p>1 Enable automatic cross-over.</p>
9	FASTRXDV	RW	0	<p>Fast RXDV Detection</p> <p>This bit is sampled on the deassertion of the PHY reset signal and is used to select whether fast RXDV detection is enabled in the PHY.</p> <p>Value Description</p> <p>0 Disable fast RXDV detection.</p> <p>1 Enable fast RXDV detection.</p>
8	FASTLUPD	RW	0	<p>FAST Link-Up in Parallel Detect</p> <p>This bit is sampled on the deassertion of the PHY reset signal and is used as the default value for the <code>FLUPPD</code> bit of the Ethernet PHY Configuration 2 (EPHYCFG2) register, PHY offset 0x00A.</p>
7	EXTFD	RW	0	<p>Extended Full Duplex Ability</p> <p>This bit is sampled on the deassertion of the PHY reset signal and is used as the default value for the <code>EXTFD</code> bit of the Ethernet PHY Configuration 2 (EPHYCFG2) register, PHY offset 0x00A.</p>
6	FASTANEN	RW	0	<p>Fast Auto Negotiation Enable</p> <p>This bit is sampled on the deassertion of the PHY reset signal and is used as the default for the <code>FASTANEN</code> bit of the Ethernet PHY Configuration 1 (EPHYCFG1) register, PHY offset 0x009.</p>
5:4	FASTANSEL	RW	0	<p>Fast Auto Negotiation Select</p> <p>These bits are sampled on the deassertion of the PHY reset signal and are used as the defaults for the <code>FANSEL</code> bit field of the Ethernet PHY Configuration 1 (EPHYCFG1) register, PHY offset 0x009.</p>
3	ANEN	RW	1	<p>Auto Negotiation Enable</p> <p>This bit is sampled on the deassertion of the PHY reset signal and is to select whether auto-negotiation is enabled.</p> <p>Value Description</p> <p>0 Auto-negotiation disabled.</p> <p>1 Auto-negotiation enabled.</p>

Bit/Field	Name	Type	Reset	Description
2:1	ANMODE	RW	3	<p>Auto Negotiation Mode</p> <p>These bits are sampled on the deassertion of the PHY reset signal and are used to determine the auto-negotiation mode of the PHY.</p> <p>Value Description</p> <p>0x0 When ANEN = 0x0, the mode is 10Base-T, Half-Duplex When ANEN=0x1, the mode is 10Base-T, Half/Full-Duplex</p> <p>0x1 When ANEN = 0x0, the mode is 10Base-T, Full-Duplex When ANEN=0x1, the mode is 100Base-TX, Half/Full-Duplex</p> <p>0x2 When ANEN = 0x0, the mode is 100Base-TX, Half-Duplex When ANEN=0x1, the mode is 10Base-T,Half-Duplex 100Base-TX, Half-Duplex</p> <p>0x3 When ANEN = 0x0, the mode is 100Base-TX, Full-Duplex When ANEN=0x1, the mode is 10Base-T,Half/Full-Duplex 100Base-TX, Half/Full-Duplex</p>
0	PHYHOLD	RW	0	<p>Ethernet PHY Hold</p> <p>This bit is sampled on the deassertion of the PHY reset signal and is used to keep the PHY from transmitting energy on the line.</p> <p>Value Description</p> <p>0 PHY transmits energy on the line.</p> <p>1 PHY is held off from transmitting energy on the line.</p>

Register 68: Ethernet MAC Clock Configuration Register (EMACCC), offset 0xFC8

The following register is used to configure the clocks of the Ethernet Controller.

Ethernet MAC Clock Configuration Register (EMACCC)

Base 0x400E.C000

Offset 0xFC8

Type RO, reset 0x0000.0000

	31	30	29	28	27	26	25	24	23	22	21	20	19	18	17	16	
	reserved													PTPCEN	POL	reserved	
Type	RO	RO	RO	RO	RO	RO	RO	RO	RO	RO	RO	RO	RO	RO	RW	RW	RO
Reset	0	0	0	0	0	0	0	0	0	0	0	0	0	0	0	0	0
	15	14	13	12	11	10	9	8	7	6	5	4	3	2	1	0	
	reserved																
Type	RO	RO	RO	RO	RO	RO	RO	RO	RO	RO	RO	RO	RO	RO	RO	RO	
Reset	0	0	0	0	0	0	0	0	0	0	0	0	0	0	0	0	

Bit/Field	Name	Type	Reset	Description
31:19	reserved	RO	0	Software should not rely on the value of a reserved bit. To provide compatibility with future products, the value of a reserved bit should be preserved across a read-modify-write operation.
18	PTPCEN	RW	0	PTP Clock Reference Enable The PTP clock reference is MOSC. This bit enables the MOSC to drive the PTP clock reference of the Ethernet MAC. Value Description 0 PTP clock reference is disabled. 1 PTP clock reference is enabled.
17	POL	RW	0	LED Polarity Control This bit controls the polarity of the LED outputs coming from the Ethernet PHY. Value Description 0 LEDs are active high. 1 LEDs are active low.
16:0	reserved	RO	0	Software should not rely on the value of a reserved bit. To provide compatibility with future products, the value of a reserved bit should be preserved across a read-modify-write operation.

Register 69: Ethernet PHY Raw Interrupt Status (EPHYRIS), offset 0xFD0

The **Ethernet PHY Raw Interrupt Status (EPHYRIS)** register provides the raw interrupt status of the integrated Ethernet PHY.

Ethernet PHY Raw Interrupt Status (EPHYRIS)

Base 0x400E.C000

Offset 0xFD0

Type RO, reset 0x0000.0000

	31	30	29	28	27	26	25	24	23	22	21	20	19	18	17	16
	reserved															
Type	RO	RO	RO	RO	RO	RO	RO	RO	RO	RO	RO	RO	RO	RO	RO	RO
Reset	0	0	0	0	0	0	0	0	0	0	0	0	0	0	0	0
	15	14	13	12	11	10	9	8	7	6	5	4	3	2	1	0
	reserved															INT
Type	RO	RO	RO	RO	RO	RO	RO	RO	RO	RO	RO	RO	RO	RO	RO	RO
Reset	0	0	0	0	0	0	0	0	0	0	0	0	0	0	0	0

Bit/Field	Name	Type	Reset	Description
31:1	reserved	RO	0	Software should not rely on the value of a reserved bit. To provide compatibility with future products, the value of a reserved bit should be preserved across a read-modify-write operation.
0	INT	RO	0	Ethernet PHY Raw Interrupt Status

Value Description

0	No interrupt has triggered.
1	The Ethernet PHY has signaled an interrupt.

Register 70: Ethernet PHY Interrupt Mask (EPHYIM), offset 0xFD4

The **Ethernet PHY Interrupt Mask (EPHYIM)** register provides the raw interrupt status of the integrated Ethernet PHY.

Ethernet PHY Interrupt Mask (EPHYIM)

Base 0x400E.C000

Offset 0xFD4

Type RW, reset 0x0000.0000

	31	30	29	28	27	26	25	24	23	22	21	20	19	18	17	16
	reserved															
Type	RO	RO	RO	RO	RO	RO	RO	RO	RO	RO	RO	RO	RO	RO	RO	RO
Reset	0	0	0	0	0	0	0	0	0	0	0	0	0	0	0	0
	15	14	13	12	11	10	9	8	7	6	5	4	3	2	1	0
	reserved															INT
Type	RO	RO	RO	RO	RO	RO	RO	RO	RO	RO	RO	RO	RO	RO	RO	RW
Reset	0	0	0	0	0	0	0	0	0	0	0	0	0	0	0	0

Bit/Field	Name	Type	Reset	Description
31:1	reserved	RO	0	Software should not rely on the value of a reserved bit. To provide compatibility with future products, the value of a reserved bit should be preserved across a read-modify-write operation.
0	INT	RW	0	Ethernet PHY Interrupt Mask

Value Description

- | | |
|---|--|
| 0 | An Ethernet PHY interrupt is suppressed and not sent to the interrupt controller. |
| 1 | An Ethernet PHY interrupt is sent to the interrupt controller when the <code>INT</code> bit is set in the EPHYRIS register. |

Register 71: Ethernet PHY Masked Interrupt Status and Clear (EPHYMISC), offset 0xFD8

The **Ethernet Masked Interrupt Status and Clear (EPHYMISC)** register displays the masked interrupt status of the integrated Ethernet PHY and can be written to clear the **EPHYRIS** register.

This register is used for clearing the **EPHYRIS** register bits.

Ethernet PHY Masked Interrupt Status and Clear (EPHYMISC)

Base 0x400E.C000

Offset 0xFD8

Type RW1C, reset 0x0000.0000

	31	30	29	28	27	26	25	24	23	22	21	20	19	18	17	16	
	reserved																
Type	RO	RO	RO	RO	RO	RO	RO	RO	RO	RO	RO	RO	RO	RO	RO	RO	
Reset	0	0	0	0	0	0	0	0	0	0	0	0	0	0	0	0	
	15	14	13	12	11	10	9	8	7	6	5	4	3	2	1	0	
	reserved															INT	
Type	RO	RO	RO	RO	RO	RO	RO	RO	RO	RO	RO	RO	RO	RO	RO	RO	RW1C
Reset	0	0	0	0	0	0	0	0	0	0	0	0	0	0	0	0	0

Bit/Field	Name	Type	Reset	Description
31:1	reserved	RO	0	Software should not rely on the value of a reserved bit. To provide compatibility with future products, the value of a reserved bit should be preserved across a read-modify-write operation.
0	INT	RW1C	0	<p>Ethernet PHY Status and Clear register</p> <p>Reading this register provides a result which is the logical AND of the EPHYRIS and EPHYIM registers. A write of 1 to a bit of this register clears the corresponding bit in the EPHYRIS register.</p> <p>Note: The Ethernet MAC interrupt is an OR'd summary of both the masked EMACRIS register output and this register. When an Ethernet MAC interrupt is asserted, software must check both the EMACRIS and EMACIM registers along with this register.</p>

23.8 Ethernet PHY Register Descriptions

This section lists and describes the PHY registers, in numerical order by address. Also see "Ethernet MAC Register Descriptions" on page 1594.

Register 72: Ethernet PHY Basic Mode Control - MR0 (EPHYBMCR), address 0x000

This register describes the basic mode controls available to the EPHY. The reset state of the ANEN bit is controlled by the **EMACPC** register.

Ethernet PHY Basic Mode Control - MR0 (EPHYBMCR)

Base n/a

Address 0x000

Type RW, reset 0x3100

	15	14	13	12	11	10	9	8	7	6	5	4	3	2	1	0
	MIIRESET	MILOOPBK	SPEED	ANEN	PWRDWN	ISOLATE	RESTARTAN	DUPLEXM	COLLTST	reserved						
Type	RW	RW	RW	RW	RW	RW	RW	RW	RW	RO	RO	RO	RO	RO	RO	RO
Reset	0	0	1	1	0	0	0	1	0	0	0	0	0	0	0	0

Bit/Field	Name	Type	Reset	Description				
15	MIIRESET	RW	0	<p>MII Register reset</p> <p>Writing a 1 to this bit resets the contents of the MII-related registers, EPHYBMCR (0x000) EPHYANA (0x004) and EPHYANNPTR (0x007) registers. When the reset operation is done, this bit is cleared to 0 automatically.</p> <p>Value Description</p> <table border="1"> <tr> <td>0</td> <td>Normal operation.</td> </tr> <tr> <td>1</td> <td>Initiate MII Reset / Reset in Process.</td> </tr> </table>	0	Normal operation.	1	Initiate MII Reset / Reset in Process.
0	Normal operation.							
1	Initiate MII Reset / Reset in Process.							
14	MILOOPBK	RW	0	<p>MII Loopback</p> <p>When MII loopback mode is activated, the transmitter data presented on MII TXD is looped back to MII RXD internally.</p> <p>Value Description</p> <table border="1"> <tr> <td>0</td> <td>Normal operation.</td> </tr> <tr> <td>1</td> <td>MII Loopback enabled.</td> </tr> </table>	0	Normal operation.	1	MII Loopback enabled.
0	Normal operation.							
1	MII Loopback enabled.							
13	SPEED	RW	1	<p>Speed Select</p> <p>When auto-negotiation is disabled writing to this bit allows the port speed to be selected.</p> <p>Value Description</p> <table border="1"> <tr> <td>0</td> <td>10Mbps</td> </tr> <tr> <td>1</td> <td>100Mbps</td> </tr> </table>	0	10Mbps	1	100Mbps
0	10Mbps							
1	100Mbps							
12	ANEN	RW	1	<p>Auto-Negotiate Enable</p> <p>Value Description</p> <table border="1"> <tr> <td>0</td> <td>Auto-Negotiation Disabled – the SPEED bit and the DUPLEXM bit determine the port speed and duplex mode.</td> </tr> <tr> <td>1</td> <td>Auto-Negotiation Enabled – the SPEED bit and the DUPLEXM bit of this register are ignored when this bit is set.</td> </tr> </table>	0	Auto-Negotiation Disabled – the SPEED bit and the DUPLEXM bit determine the port speed and duplex mode.	1	Auto-Negotiation Enabled – the SPEED bit and the DUPLEXM bit of this register are ignored when this bit is set.
0	Auto-Negotiation Disabled – the SPEED bit and the DUPLEXM bit determine the port speed and duplex mode.							
1	Auto-Negotiation Enabled – the SPEED bit and the DUPLEXM bit of this register are ignored when this bit is set.							

Bit/Field	Name	Type	Reset	Description
11	PWRDWN	RW	0	<p>Power Down</p> <p>Setting this bit powers down the PHY. Only minimal register functionality is enabled during the power down condition.</p> <p>Value Description</p> <p>0 Normal operation</p> <p>1 Power-down modes are enabled: General Power Down Mode, Active Sleep Mode and Passive Sleep Mode (see Ethernet PHY Specific Control (EPHYSCR) register, offset 0x011).</p>
10	ISOLATE	RW	0	<p>Port Isolate</p> <p>Value Description</p> <p>0 Normal operation.</p> <p>1 Isolates the Port from the MII with the exception of the serial management.</p>
9	RESTARTAN	RW	0	<p>Restart Auto-Negotiation</p> <p>Value Description</p> <p>0 Normal operation.</p> <p>1 Auto-Negotiation process is re-initiated. If Auto-Negotiation is disabled ($ANEN = 0$), this bit is ignored. This bit is self-clearing and returns a value of 1 until Auto-Negotiation is initiated, whereupon it self-clears. Operation of the Auto-Negotiation process is not affected by the management entity clearing this bit..</p>
8	DUPLEXM	RW	1	<p>Duplex Mode</p> <p>When auto-negotiation is disabled writing to this bit allows the port-duplex capability to be selected.</p> <p>Value Description</p> <p>0 Half Duplex operation.</p> <p>1 Full Duplex Operation</p>
7	COLLTST	RW	0	<p>Collision Test</p> <p>When set, this bit causes the $EN0COL$ signal to be asserted in response to the assertion of $EN0TXEN$ within 512 bit times. The $EN0COL$ signal is deasserted within four bit times in response to the deassertion of $EN0TXEN$.</p> <p>Value Description</p> <p>0 Normal operation</p> <p>1 Collision test enabled.</p>
6:0	reserved	RO	0	<p>Software should not rely on the value of a reserved bit. To provide compatibility with future products, the value of a reserved bit should be preserved across a read-modify-write operation.</p>

Register 73: Ethernet PHY Basic Mode Status - MR1 (EPHYBMSR), address 0x001

This register reflects the basic mode features that are available in the EPHY.

Ethernet PHY Basic Mode Status - MR1 (EPHYBMSR)

Base n/a

Address 0x001

Type RO, reset 0x7849

	15	14	13	12	11	10	9	8	7	6	5	4	3	2	1	0
	reserved	100BTXFD	100BTXHD	10BTFD	10BTHD	reserved				MFPRESUP	ANC	RFAULT	ANEN	LINKSTAT	JABBER	EXTEN
Type	RO	RO	RO	RO	RO	RO	RO	RO	RO	RO	RO	RO	RO	RO	RO	RO
Reset	0	1	1	1	1	0	0	0	0	1	0	0	1	0	0	1

Bit/Field	Name	Type	Reset	Description
15	reserved	RO	0	Software should not rely on the value of a reserved bit. To provide compatibility with future products, the value of a reserved bit should be preserved across a read-modify-write operation.
14	100BTXFD	RO	1	100Base-TX Full Duplex Capable Value Description 0 Device does not support 100Base-TX in full duplex mode. 1 Device supports 100Base-TX in full duplex mode.
13	100BTXHD	RO	1	100Base-TX Half Duplex Capable Value Description 0 The device does not support 100Base-TX in half duplex mode. 1 The device supports 100Base-TX in half duplex mode.
12	10BTFD	RO	1	10 Base-T Full Duplex Capable Value Description 0 The device does not support 10Base-T in full duplex mode. 1 Device able to perform 10Base-T in full duplex mode.
11	10BTHD	RO	1	10 Base-T Half Duplex Capable Value Description 0 Device not able to perform 10Base-T in half duplex mode. 1 Device able to perform 10Base-T in half duplex mode.
10:7	reserved	RO	0	Software should not rely on the value of a reserved bit. To provide compatibility with future products, the value of a reserved bit should be preserved across a read-modify-write operation.

Bit/Field	Name	Type	Reset	Description
6	MFPRESUP	RO	1	<p>Preamble Suppression Capable</p> <p>Value Description</p> <p>0 The device does not perform management transactions with preambles suppressed.</p> <p>1 The device performs management transactions with preambles suppressed. For this mode, the 32-bits of preamble are needed only once after reset, invalid opcode or invalid turnaround.</p>
5	ANC	RO	0	<p>Auto-Negotiation Complete</p> <p>Value Description</p> <p>0 Auto-Negotiation process not complete (either still in process, disabled, or reset)</p> <p>1 Auto-Negotiation process complete.</p>
4	RFAULT	RO	0	<p>Remote Fault</p> <p>Value Description</p> <p>0 No remote fault condition detected.</p> <p>1 Remote Fault condition detected (cleared on read or by reset). Fault criteria: Far End Fault Indication or notification from Link Partner of Remote Fault.</p>
3	ANEN	RO	1	<p>Auto Negotiation Enabled</p> <p>Value Description</p> <p>0 Device is not able to perform Auto-Negotiation.</p> <p>1 Device is able to perform Auto-Negotiation.</p>
2	LINKSTAT	RO	0	<p>Link Status</p> <p>Value Description</p> <p>0 Link not established.</p> <p>1 Valid link established (for either 10 or 100Mbs operation).</p>
1	JABBER	RO	0	<p>Jabber Detect</p> <p>This bit is implemented with a latching function, such that the occurrence of a jabber condition causes it to set until it is cleared by a read from this register, by the management interface, or by a reset.</p> <p>Value Description</p> <p>0 No Jabber condition detected.</p> <p>1 Jabber condition detected</p>

Bit/Field	Name	Type	Reset	Description
0	EXTEN	RO	1	Extended Capability Enable
				Value Description
				0 Basic register set capabilities only.
				1 Extended register capabilities.

Register 74: Ethernet PHY Identifier Register 1 - MR2 (EPHYID1), address 0x002

The **Ethernet PHY Identifier 1 and 2 (EPHYIDn)** registers together form a unique identifier. The identifier consists of a concatenation of the Organizationally Unique Identifier (OUI), the vendor's model number and the model revision number. A PHY may return a value of zero in each of the 32 bits of the PHY Identifier if desired. The PHY Identifier is intended to support network management. The Texas Instruments IEEE-assigned OUI is 0x080028. This OUI field is broken into two fields in the **EPHYID1** and **EPHYID2** register. The most significant OUI field, **OUI_MSB** in the **EPHYID1** register, is equal to 0x0002 (the two most significant bits of the OUI are ignored). The least significant OUI field, **OUI_LSB** in the **EPHYID2** register, is equal to 0x28.

Ethernet PHY Identifier Register 1 - MR2 (EPHYID1)

Base n/a
Address 0x002
Type R, reset 0x2000

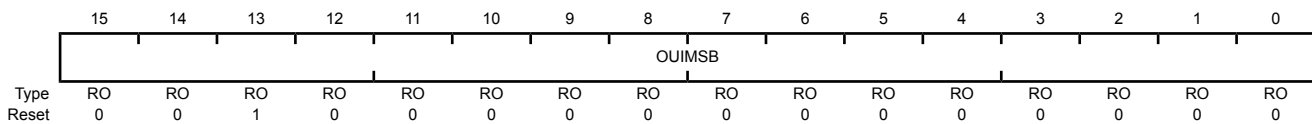

Bit/Field	Name	Type	Reset	Description
15:0	OUI_MSB	RO	0x2000	OUI Most Significant Bits OUI[21:6] = 0x200. The most significant two bits of the OUI are ignored (the IEEE standard refers to these as bits 1 and 2).

Register 75: Ethernet PHY Identifier Register 2 - MR3 (EPHYID2), address 0x003

The **Ethernet PHY Identifier 1 and 2 (EPHYIDn)** registers together form a unique identifier. The identifier consists of a concatenation of the Organizationally Unique Identifier (OUI), the vendor's model number and the model revision number. A PHY may return a value of zero in each of the 32 bits of the PHY Identifier if desired. The PHY Identifier is intended to support network management. The Texas Instruments IEEE-assigned OUI is 0x080028. This OUI field is broken into two fields in the **EPHYID1** and **EPHYID2** register. The most significant OUI field, **OUI_MSB** in the **EPHYID1** register, is equal to 0x0002 (the two most significant bits of the OUI are ignored). The least significant OUI field, **OUI_LSB** in the **EPHYID2** register, is equal to 0x28.

Ethernet PHY Identifier Register 2 - MR3 (EPHYID2)

Base n/a
Address 0x003
Type R, reset 0xA221

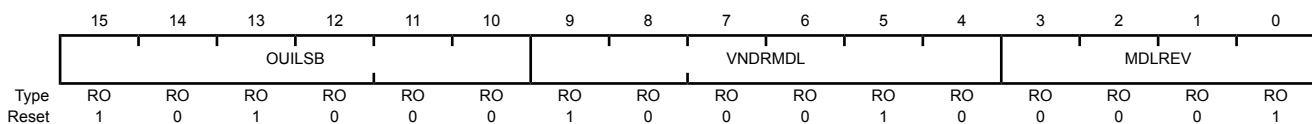

Bit/Field	Name	Type	Reset	Description
15:10	OUI LSB	RO	0x28	OUI Least Significant Bits Bits 19 to 24 of the OUI (0x080028) are mapped from bits 15 to 10 of this register respectively.
9:4	VNDRMDL	RO	0x22	Vendor Model Number The six bits of vendor model number are mapped from bits 9 to 4 (most significant bit to bit 9).
3:0	MDLREV	RO	0x1	Model Revision Number Four bits of the vendor model revision number are mapped from bits 3 to 0 (most significant bit to bit 3). This field is incremented for all major device changes.

Register 76: Ethernet PHY Auto-Negotiation Advertisement - MR4 (EPHYANA), address 0x004

This register contains the advertised abilities of this device as they are transmitted to its link partner during Auto-Negotiation.

Ethernet PHY Auto-Negotiation Advertisement - MR4 (EPHYANA)

Base n/a
Address 0x004
Type RW, reset 0x01E1

	15	14	13	12	11	10	9	8	7	6	5	4	3	2	1	0
	NP	reserved	RF	reserved	ASMDUP	PAUSE	100BT4	100BTXFD	100BTX	10BTFD	10BT			SELECT		
Type	RW	RO	RW	RO	RW	RW	RO	RW	RW	RW	RW	RW	RW	RW	RW	RW
Reset	0	0	0	0	0	0	0	1	1	1	1	0	0	0	0	1

Bit/Field	Name	Type	Reset	Description
15	NP	RW	0	Next Page Indication Value Description 0 Next Page Transfer not desired. 1 Next Page Transfer desired.
14	reserved	RO	0	Software should not rely on the value of a reserved bit. To provide compatibility with future products, the value of a reserved bit should be preserved across a read-modify-write operation.
13	RF	RW	0	Remote Fault Value Description 0 No Remote Fault detected. 1 Advertises that this device has detected a Remote Fault.
12	reserved	RO	0	Software should not rely on the value of a reserved bit. To provide compatibility with future products, the value of a reserved bit should be preserved across a read-modify-write operation.
11	ASMDUP	RW	0	Asymmetric PAUSE support for Full Duplex Links Encoding and resolution of PAUSE bits is defined in IEEE 802.3 Annex 28B, Tables 28B-2 and 28B-3, respectively. Pause resolution status is reported in the Pause Status bits [13:12], of the Ethernet PHY Control (EPHYCTL) register. Value Description 0 Asymmetric PAUSE not implemented. 1 Asymmetric PAUSE implemented. Advertise that the MAC has implemented both the optional MAC control sublayer and the pause function as specified in clause 31 and annex 31B of IEEE802.3u.

Bit/Field	Name	Type	Reset	Description
10	PAUSE	RW	0	<p>PAUSE Support for Full Duplex Links</p> <p>The PAUSE bit indicates that the device is capable of providing the symmetric PAUSE functions as defined in Annex 31B.</p> <p>Encoding and resolution of PAUSE bits is defined in IEEE 802.3 Annex 28B, Tables 28B-2 and 28B-3, respectively. Pause resolution status is reported in the Ethernet PHY Control (EPHYCTL) register.</p> <p>Value Description</p> <p>0 MAC PAUSE not implemented</p> <p>1 MAC PAUSE implemented. Advertise that the MAC has implemented both the optional MAC control sub-layer and the pause function as specified in clause 31 and annex 31B of 802.3u.</p>
9	100BT4	RO	0	<p>100Base-T4 Support</p> <p>Value Description</p> <p>0 100Base-T4 not supported by the internal PHY.</p> <p>1 100Base-T4 is supported by the internal PHY.</p>
8	100BTXFD	RW	1	<p>100Base-TX Full Duplex Support</p> <p>Value Description</p> <p>0 100Base-TX Full Duplex not supported by the internal PHY.</p> <p>1 100Base-TX Full Duplex is supported by the internal PHY.</p>
7	100BTX	RW	1	<p>100Base-TX Support</p> <p>Value Description</p> <p>0 100Base-TX not supported by the internal PHY.</p> <p>1 100Base-TX is supported by the internal PHY.</p>
6	10BTFD	RW	1	<p>10Base-T Full Duplex Support</p> <p>Value Description</p> <p>0 10Base-T Full Duplex not supported by the internal PHY.</p> <p>1 10Base-T Full Duplex is supported by the internal PHY.</p>
5	10BT	RW	1	<p>10Base-T Support</p> <p>Value Description</p> <p>0 10Base-T not supported by the internal PHY.</p> <p>1 10Base-T is supported by the internal PHY.</p>
4:0	SELECT	RW	0x1	<p>Protocol Selection</p> <p>These bits contain the binary encoded protocol selector supported by this port. 0x1 indicates that this device supports IEEE 802.3u.</p>

Register 77: Ethernet PHY Auto-Negotiation Link Partner Ability - MR5 (EPHYANLPA), address 0x005

This register contains the advertised abilities of the Link Partner as received during Auto-Negotiation. The content changes after the successful auto-negotiation if next-pages are supported.

Ethernet PHY Auto-Negotiation Link Partner Ability - MR5 (EPHYANLPA)

Base n/a

Address 0x005

Type RO, reset 0x0000

	15	14	13	12	11	10	9	8	7	6	5	4	3	2	1	0
	NP	ACK	RF	reserved	ASMDUP	PAUSE	100BT4	100BTXFD	100BTX	10BTFD	10BT	SELECT				
Type	RO	RO	RO	RO	RW	RO	RO	RO	RO	RO	RO	RO	RO	RO	RO	RO
Reset	0	0	0	0	0	0	0	0	0	0	0	0	0	0	0	1

Bit/Field	Name	Type	Reset	Description
15	NP	RO	0	Next Page Indication Value Description 0 Link Partner does not desire Next Page Transfer. 1 Link Partner desires Next Page Transfer.
14	ACK	RO	0	Acknowledge Value Description 0 Not acknowledged. The Auto-Negotiation state machine will automatically control the this bit based on the incoming FLP bursts. 1 Link Partner acknowledges reception of the ability data word.
13	RF	RO	0	Remote Fault Value Description 0 No remote fault indicated by link partner. 1 Remote fault indicated by link partner.
12	reserved	RO	0x0	Software should not rely on the value of a reserved bit. To provide compatibility with future products, the value of a reserved bit should be preserved across a read-modify-write operation.
11	ASMDUP	RW	0	Asymmetric PAUSE Value Description 0 Asymmetric pause is not supported by the Link Partner. 1 Asymmetric pause is supported by the Link Partner.
10	PAUSE	RO	0	PAUSE Value Description 0 Pause function is not supported by the Link Partner. 1 Pause function is supported by the Link Partner.

Bit/Field	Name	Type	Reset	Description
9	100BT4	RO	0	<p>100Base-T4 Support</p> <p>Value Description</p> <p>0 100Base-T4 is not supported by the Link Partner.</p> <p>1 100Base-T4 is supported by the Link Partner.</p>
8	100BTXFD	RO	0	<p>100Base-TX Full Duplex Support</p> <p>Value Description</p> <p>0 100Base-TX Full Duplex is not supported by the Link Partner.</p> <p>1 100Base-TX Full Duplex is supported by the Link Partner.</p>
7	100BTX	RO	0	<p>100Base-TX Support</p> <p>Value Description</p> <p>0 100Base-TX is not supported by the Link Partner.</p> <p>1 100Base-TX is supported by the Link Partner.</p>
6	10BTFD	RO	0	<p>10Base-T Full Duplex Support</p> <p>Value Description</p> <p>0 10Base-T Full Duplex is not supported by the Link Partner.</p> <p>1 10Base-T Full Duplex is supported by the Link Partner.</p>
5	10BT	RO	0	<p>10Base-T Support</p> <p>Value Description</p> <p>0 10Base-T is not supported by the Link Partner.</p> <p>1 10Base-T is supported by the Link Partner.</p>
4:0	SELECT	RO	0x1	<p>Protocol Selection</p> <p>Link Partner's binary encoded protocol selector.</p>

Register 78: Ethernet PHY Auto-Negotiation Expansion - MR6 (EPHYANER), address 0x006

This register contains additional local device and link partner status information.

Ethernet PHY Auto-Negotiation Expansion - MR6 (EPHYANER)

Base n/a

Address 0x006

Type RO, reset 0x0004

	15	14	13	12	11	10	9	8	7	6	5	4	3	2	1	0
	reserved											PDF	LPNPABLE	NPABLE	PAGERX	LPANABLE
Type	RO	RO	RO	RO	RO	RO	RO	RO	RO	RO	RO	RO	RO	RO	RO	RO
Reset	0	0	0	0	0	0	0	0	0	0	0	0	0	1	0	0

Bit/Field	Name	Type	Reset	Description
15:5	reserved	RO	0	Software should not rely on the value of a reserved bit. To provide compatibility with future products, the value of a reserved bit should be preserved across a read-modify-write operation.
4	PDF	RO	0	Parallel Detection Fault Value Description 0 A fault has not been detected. 1 A fault has been detected via the Parallel Detection function.
3	LPNPABLE	RO	0	Link Partner Next Page Able Value Description 0 Link Partner does not support next page. 1 Link Partner does support next page.
2	NPABLE	RO	1	Next Page Able Value Description 0 Indicates local device is not able to send additional next pages. 1 Indicates local device is able to send additional next pages
1	PAGERX	RO	0	Link Code Word Page Received Value Description 0 Link Code Word has not been received. 1 Link Code Word has been received. This bit is cleared when read.
0	LPANABLE	RO	0	Link Partner Auto-Negotiation Able Value Description 0 Indicates that the Link Partner does not support Auto-Negotiation. 1 Indicates that the Link Partner supports Auto-Negotiation.

Register 79: Ethernet PHY Auto-Negotiation Next Page TX - MR7 (EPHYANNPTR), address 0x007

This register contains the next page information sent by this device to its link partner during Auto-Negotiation.

Ethernet PHY Auto-Negotiation Next Page TX - MR7 (EPHYANNPTR)

Base n/a
Address 0x007
Type RW, reset 0x2001

	15	14	13	12	11	10	9	8	7	6	5	4	3	2	1	0
	NP	reserved	MP	ACK2	TOGTX	CODE										
Type	RW	RO	RW	RW	RO	RW	RW	RW	RW	RW	RW	RW	RW	RW	RW	RW
Reset	0	0	0	0	0	0	0	0	0	0	0	0	0	0	0	1

Bit/Field	Name	Type	Reset	Description
15	NP	RW	0	Next Page Indication Value Description 0 No other next-page transfer desired. 1 Another next page desired.
14	reserved	RO	0x0	Software should not rely on the value of a reserved bit. To provide compatibility with future products, the value of a reserved bit should be preserved across a read-modify-write operation.
13	MP	RW	0	Message Page Value Description 0 Unformatted Page. 1 Message Page.
12	ACK2	RW	0	Acknowledge 2 Value Description 0 Cannot comply with message. 1 Can comply with message.
11	TOGTX	RO	0	Toggle Toggle is used by the arbitration function within auto-negotiation to synchronize with the Link Partner during next page exchange. This bit always takes the opposite value of the toggle bit in the previously exchanged Link Code Word. Value Description 0 Value of toggle bit in previously transmitted Link Code Word was 1. 1 Value of toggle bit in previously transmitted Link Code Word was 0.

Bit/Field	Name	Type	Reset	Description
10:0	CODE	RW	0x1	<p>Code</p> <p>This field represents the code field of the next page transmission. If the <code>MP</code> bit is set (bit 13 of this register), then the code is interpreted as a Message Page, as defined in annex 28C of IEEE 802.3u.</p> <p>Otherwise, the code is interpreted as an Unformatted Page, and the interpretation is application specific.</p> <p>The default value of the <code>CODE</code> field represents a Null Page as defined in Annex 28C of IEEE 802.3u.</p>

Register 80: Ethernet PHY Auto-Negotiation Link Partner Ability Next Page - MR8 (EPHYANLNPTR), address 0x008

This register contains the next page information sent by this device to its Link Partner during Auto-Negotiation.

Ethernet PHY Auto-Negotiation Link Partner Ability Next Page - MR8 (EPHYANLNPTR)

Base n/a
Address 0x008
Type RO, reset 0x0000

	15	14	13	12	11	10	9	8	7	6	5	4	3	2	1	0
	NP	ACK	MP	ACK2	TOG	CODE										
Type	RO	RO	RO	RO	RO	RO	RO	RO	RO	RO	RO	RO	RO	RO	RO	RO
Reset	0	0	0	0	0	0	0	0	0	0	0	0	0	0	0	0

Bit/Field	Name	Type	Reset	Description
15	NP	RO	0	Next Page Indication Value Description 0 No other next page transfer desired. 1 Another next page desired.
14	ACK	RO	0	Acknowledge The auto-negotiation state machine automatically controls this bit based on the incoming fast-link pulse (FLP) bursts. Software should not attempt to write to this bit. Value Description 0 Not acknowledged. 1 Link Partner acknowledges reception of the ability data word.
13	MP	RO	0	Message Page Value Description 0 Unformatted Page. 1 Message Page.
12	ACK2	RO	0	Acknowledge 2 Acknowledge2 is used by the next page function to indicate that Local Device has the ability to comply with the message received. Value Description 0 Link Partner cannot comply to next-page message. 1 Link Partner has the ability to comply to next-page message.

Bit/Field	Name	Type	Reset	Description				
11	TOG	RO	0	<p>Toggle</p> <p>Toggle is used by the Arbitration function within Auto-Negotiation to synchronize with the Link Partner during Next Page exchange. This bit always takes the opposite value of the Toggle bit in the previously exchanged Link Code Word</p> <p>Value Description</p> <table border="1"> <tr> <td>0</td> <td>Value of toggle bit in previously transmitted Link Code Word was 1.</td> </tr> <tr> <td>1</td> <td>Value of toggle bit in previously transmitted Link Code Word was 0.</td> </tr> </table>	0	Value of toggle bit in previously transmitted Link Code Word was 1.	1	Value of toggle bit in previously transmitted Link Code Word was 0.
0	Value of toggle bit in previously transmitted Link Code Word was 1.							
1	Value of toggle bit in previously transmitted Link Code Word was 0.							
10:0	CODE	RO	0x0	<p>Code</p> <p>This field represents the code field of the next page transmission. If the MP bit is set (bit 13 of this RW register), then the code is interpreted as a Message Page, as defined in annex 28C of IEEE 802.3u. Otherwise, the code is interpreted as an Unformatted Page, and the interpretation is application specific.</p> <p>The default value of the CODE represents a Null Page as defined in Annex 28C of IEEE 802.3u.</p>				

Register 81: Ethernet PHY Configuration 1 - MR9 (EPHYCFG1), address 0x009

This register configuration for the Ethernet PHY. These configuration values are programmed by the system processor after a POR. The **DONE** bit in the **EPHYCFG1** register is set when configuration is complete. This register is used when the user requires a configuration different from what is provided in the **EMACPC** register.

Ethernet PHY Configuration 1 - MR9 (EPHYCFG1)

Base n/a
Address 0x009
Type RW, reset 0x0000

	15	14	13	12	11	10	9	8	7	6	5	4	3	2	1	0
	DONE	reserved						TDRAR	LLR	FAMDIX	RAMDIX	FASTANEN	FANSEL		FRXDVDDET	reserved
Type	WO	RO	RO	RO	RO	RO	RO	RW	RW	RW	RW	RW	RW	RW	RW	RO
Reset	0	0	0	0	0	0	0	0	0	0	0	0	0	0	0	0

Bit/Field	Name	Type	Reset	Description				
15	DONE	WO	0	<p>Configuration Done</p> <p>This bit reads as a zero. The application must write a one to this bit to terminate the PHYHOLD mode set in the EMACPC register and wake up the EPHY.</p> <p>Value Description</p> <table border="0"> <tr> <td>0</td> <td>Configuration process is not complete.</td> </tr> <tr> <td>1</td> <td>Configuration process is complete, and the PHY can continue and complete its internal reset sequence.</td> </tr> </table>	0	Configuration process is not complete.	1	Configuration process is complete, and the PHY can continue and complete its internal reset sequence.
0	Configuration process is not complete.							
1	Configuration process is complete, and the PHY can continue and complete its internal reset sequence.							
14:9	reserved	RO	0	Software should not rely on the value of a reserved bit. To provide compatibility with future products, the value of a reserved bit should be preserved across a read-modify-write operation.				
8	TDRAR	RW	0	<p>TDR Auto-Run at Link Down</p> <p>Value Description</p> <table border="0"> <tr> <td>0</td> <td>Disable automatic execution of TDR.</td> </tr> <tr> <td>1</td> <td>Enable execution of TDR procedure after link down event.</td> </tr> </table>	0	Disable automatic execution of TDR.	1	Enable execution of TDR procedure after link down event.
0	Disable automatic execution of TDR.							
1	Enable execution of TDR procedure after link down event.							
7	LLR	RW	0	<p>Link Loss Recovery</p> <p>Value Description</p> <table border="0"> <tr> <td>0</td> <td>Normal Link Loss operation Link status goes down approximately 250 μs from signal loss.</td> </tr> <tr> <td>1</td> <td>Enable Link Loss Recovery mechanism This mode allows recovery from short interference and continues to hold the link up for a period of an additional few μs until the short interference is gone and the signal is OK.</td> </tr> </table>	0	Normal Link Loss operation Link status goes down approximately 250 μ s from signal loss.	1	Enable Link Loss Recovery mechanism This mode allows recovery from short interference and continues to hold the link up for a period of an additional few μ s until the short interference is gone and the signal is OK.
0	Normal Link Loss operation Link status goes down approximately 250 μ s from signal loss.							
1	Enable Link Loss Recovery mechanism This mode allows recovery from short interference and continues to hold the link up for a period of an additional few μ s until the short interference is gone and the signal is OK.							

Bit/Field	Name	Type	Reset	Description
6	FAMDIX	RW	0	<p>Fast Auto MDI/MDIX</p> <p>If both link partners are configured to work in Force 100Base-TX mode (auto-negotiation is disabled), this mode enables automatic MDI/MDIX resolution in a short time.</p> <p>Value Description</p> <p>0 Normal Auto MDI/MDIX mode.</p> <p>1 Enable Fast Auto MDI/MDIX mode.</p>
5	RAMDIX	RW	0	<p>Robust Auto MDI/MDIX</p> <p>If link partners are configured to operational modes that are not supported by normal Auto MDI/MDIX mode (like Auto-Neg versus Force 100Base-TX or Force 100Base-TX versus Force 100Base-TX), this Robust Auto MDI/MDIX mode allows MDI/MDIX resolution and prevents deadlock.</p> <p>Value Description</p> <p>0 Normal Auto MDI/MDIX mode.</p> <p>1 Enable Robust Auto MDI/MDIX resolution.</p>
4	FASTANEN	RW	0	<p>Fast Auto Negotiation Enable</p> <p>Adjusting these bits reduces the time it takes to auto-negotiate between two PHYs.</p> <p>Note: When using this option care must be taken to maintain proper operation of the system. While shortening these timer intervals may not cause problems in normal operation, there are certain situations where this may lead to problems.</p> <p>Value Description</p> <p>0 Disable Fast Auto-Negotiation mode The PHY auto-negotiates using the normal timer setting</p> <p>1 Enable Fast Auto-Negotiation mode The PHY auto-negotiates using the timer setting according to the FANSEL bits (bits [3:2] of this register)</p>

Bit/Field	Name	Type	Reset	Description										
3:2	FANSEL	RW	0	<p>Fast Auto-Negotiation Select Configuration</p> <p>This bit is preconfigured at reset by the EMACPC register. For custom configuration see "Custom Configuration" on page 1590.</p> <p>Adjusting these bits reduces the time it takes to auto-negotiate between two PHYs. In Fast AN mode, both PHYs should be configured to the same configuration. These two bits define the duration for each state of the auto-negotiation process according to the table above. The new duration time must be enabled by setting bit 4 (FASTANEN) of this register.</p> <p>Note: Using this mode in cases where both link partners are not configured to the same fast auto-negotiation configuration might produce scenarios with unexpected behavior.</p> <table border="1"> <thead> <tr> <th>Value</th> <th>Description</th> </tr> </thead> <tbody> <tr> <td>0x0</td> <td>Break Link Timer: 80 ms Link Fail Inhibit Timer: 50 ms Auto-Negate Wait Timer: 35 ms</td> </tr> <tr> <td>0x1</td> <td>Break Link Timer: 120 ms Link Fail Inhibit Timer: 75 ms Auto-Negate Wait Timer: 50 ms</td> </tr> <tr> <td>0x2</td> <td>Break Link Timer: 240 ms Link Fail Inhibit Timer: 150 ms Auto-Negate Wait Timer: 100 ms</td> </tr> <tr> <td>0x3</td> <td>reserved</td> </tr> </tbody> </table>	Value	Description	0x0	Break Link Timer: 80 ms Link Fail Inhibit Timer: 50 ms Auto-Negate Wait Timer: 35 ms	0x1	Break Link Timer: 120 ms Link Fail Inhibit Timer: 75 ms Auto-Negate Wait Timer: 50 ms	0x2	Break Link Timer: 240 ms Link Fail Inhibit Timer: 150 ms Auto-Negate Wait Timer: 100 ms	0x3	reserved
Value	Description													
0x0	Break Link Timer: 80 ms Link Fail Inhibit Timer: 50 ms Auto-Negate Wait Timer: 35 ms													
0x1	Break Link Timer: 120 ms Link Fail Inhibit Timer: 75 ms Auto-Negate Wait Timer: 50 ms													
0x2	Break Link Timer: 240 ms Link Fail Inhibit Timer: 150 ms Auto-Negate Wait Timer: 100 ms													
0x3	reserved													
1	FRXDVDET	RW	0	<p>FAST RXDV Detection</p> <p>Enabling this feature allows the PHY to pass data to the MII interface earlier. This bit is set to disabled if using the EMACPC register bits to program the PHY configuration.</p> <table border="1"> <thead> <tr> <th>Value</th> <th>Description</th> </tr> </thead> <tbody> <tr> <td>0</td> <td>Disable fast RXDV detection. The PHY operates in normal mode where an internally asserted RXDV signal is sent to the MII interface after detection of /J/K/.</td> </tr> <tr> <td>1</td> <td>An internal RXDV signal is asserted high on receive packet due to detection of /J/ symbol only. Fast RXDV detection allows the PHY to pass data to the MII interface earlier. If a consecutive /K/ does not appear, RXERR is generated.</td> </tr> </tbody> </table>	Value	Description	0	Disable fast RXDV detection. The PHY operates in normal mode where an internally asserted RXDV signal is sent to the MII interface after detection of /J/K/.	1	An internal RXDV signal is asserted high on receive packet due to detection of /J/ symbol only. Fast RXDV detection allows the PHY to pass data to the MII interface earlier. If a consecutive /K/ does not appear, RXERR is generated.				
Value	Description													
0	Disable fast RXDV detection. The PHY operates in normal mode where an internally asserted RXDV signal is sent to the MII interface after detection of /J/K/.													
1	An internal RXDV signal is asserted high on receive packet due to detection of /J/ symbol only. Fast RXDV detection allows the PHY to pass data to the MII interface earlier. If a consecutive /K/ does not appear, RXERR is generated.													
0	reserved	RO	0	Software should not rely on the value of a reserved bit. To provide compatibility with future products, the value of a reserved bit should be preserved across a read-modify-write operation.										

Register 82: Ethernet PHY Configuration 2 - MR10 (EPHYCFG2), address 0x00A

Fields in this register are used to configure the Ethernet PHY. These configuration values are programmed by the system processor after a POR. The `DONE` bit in the **EPHYCFG1** register is set when configuration is complete. This register is used when the user requires a configuration different from what is provided in the **EMACPC** register.

Ethernet PHY Configuration 2 - MR10 (EPHYCFG2)

Base n/a
Address 0x00A
Type RW, reset 0x0004

	15	14	13	12	11	10	9	8	7	6	5	4	3	2	1	0
	reserved								FLUPPD	EXTFD	ENLEDLINK	ISOMILL	RXERRIDLE	ODDNDTDIS	reserved	
Type	RO	RO	RO	RO	RO	RO	RO	RO	RO	RW	RW	RW	RW	RW	RW	RO
Reset	0	0	0	0	0	0	0	0	0	0	0	0	0	1	0	0

Bit/Field	Name	Type	Reset	Description
15:7	reserved	RO	0x0	Software should not rely on the value of a reserved bit. To provide compatibility with future products, the value of a reserved bit should be preserved across a read-modify-write operation.
6	FLUPPD	RW	0x0	Fast Link-Up in Parallel Detect Mode In fast-auto MDI-X and in robust-auto MDI-X modes (bits 6 and 5 in register EPHYCFG1), this bit is automatically set. Value Description 0 Normal Parallel Detection link establishment 1 Enable Fast Link-Up time During Parallel Detection
5	EXTFD	RW	0	Extended Full-Duplex Ability Encodes the type of PHY attached. Value Description 0 Disable extended full-duplex ability. Decision to work in full-duplex or half-duplex mode follows IEEE specification. 1 Force full-duplex while working with link partner in forced 100B-TX. When the PHY is set to Auto-Negotiation or Force 100B-TX and the link partner is operated in Force 100B-TX, the link is always full duplex
4	ENLEDLINK	RW	0	Enhanced LED Functionality Value Description 0 LED Link is ON when link is established. 1 LED Link is ON only when link is established in 100B-TX Full Duplex mode.

Bit/Field	Name	Type	Reset	Description
3	ISOMIILL	RW	0	<p>Isolate MII outputs when Enhanced Link is not Achievable</p> <p>Value Description</p> <p>0 Normal MII outputs operation</p> <p>1 When no link established in 100B-TX and Full Duplex conditions, MII outputs are tied low.</p>
2	RXERRIDLE	RW	1	<p>Detection of Receive Symbol Error During IDLE State</p> <p>Value Description</p> <p>0 Disable detection of Receive symbol error during IDLE state.</p> <p>1 Enable detection of Receive symbol error during IDLE state.</p>
1	ODDNDETDIS	RW	0	<p>Detection of Transmit Error</p> <p>Value Description</p> <p>0 Enable detection of deassertion of the internal transmit enable on an odd-nibble boundary. In this case the internal transmit enable is extended by one additional transmit clock cycle and behaves as if the internal transmit error was asserted during that additional cycle.</p> <p>1 Disable detection of internal transmit error in odd-nibble boundary.</p>
0	reserved	RO	0	<p>Software should not rely on the value of a reserved bit. To provide compatibility with future products, the value of a reserved bit should be preserved across a read-modify-write operation.</p>

Register 83: Ethernet PHY Configuration 3 - MR11 (EPHYCFG3), address 0x00B

Fields in this register are used to configure the Ethernet PHY. These configuration values are programmed by the system processor after a POR. The `DONE` bit in the **EPHYCFG1** register is set when configuration is complete. This register is used when the user requires a configuration different from what is provided in the **EMACPC** register.

Ethernet PHY Configuration 3 - MR11 (EPHYCFG3)

Base n/a
Address 0x00B
Type RW, reset 0x0000

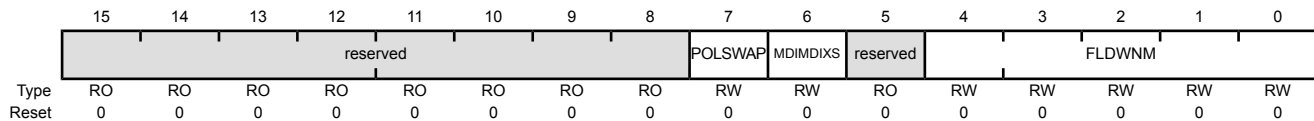

Bit/Field	Name	Type	Reset	Description
15:8	reserved	RO	0x0	Software should not rely on the value of a reserved bit. To provide compatibility with future products, the value of a reserved bit should be preserved across a read-modify-write operation.
7	POLSWAP	RW	0	Polarity Swap Value Description 0 MDI pairs normal (Receive on EN0RXIN/EN0RXIP pair, Transmit on EN0TXON/EN0TXOP pair) 1 Inverted polarity on both pairs. To enable the port mirror function, set this bit and bit 6 (MDIMDIXS) to 1.
6	MDIMDIXS	RW	0	MDI/MDIX Swap Value Description 0 MDI pairs normal (Receive on EN0RXIN/EN0RXIP pair, Transmit on EN0TXON/EN0TXOP pair) 1 Swap MDI pairs (Receive on EN0TXON/EN0TXOP pair, Transmit on EN0RXIN/EN0RXIP pair) To enable the port mirroring function, set bit 7 and this bit to 1.
5	reserved	RO	0	Software should not rely on the value of a reserved bit. To provide compatibility with future products, the value of a reserved bit should be preserved across a read-modify-write operation.

Bit/Field	Name	Type	Reset	Description
4:0	FLDWNM	RW	0x0	<p>Fast Link Down Modes</p> <p>The Fast Link Down function is an OR of the following five options. The application can enable combinations of these conditions.</p> <p>Bit 4: Drop the link due to descrambler sync loss. If this bit is enabled, the link is dropped when the receiver loses synchronization of the transmitter.</p> <p>Bit 3: Drop the link based on RX Error count of the MII interface. When a predefined number of 32 RX Error occurrences in a 10μs interval is reached, the link is dropped.</p> <p>Bit 2: Drop the link based on MLT3 Errors count (Violation of the MLT3 coding in the DSP output). When a predefined number of 20 MLT3 Error occurrences in a 10μs interval is reached, the link is dropped.</p> <p>Bit 1: Drop the link based on Low SNR Threshold. When a predefined number of 20 Threshold crossing occurrences in a 10μs interval is reached, the link is dropped.</p> <p>Bit 0: Drop the link based on Signal/Energy loss indication – When the Energy detector indicates Energy Loss, the link is dropped. Typical reaction time is 10μs.</p>

Register 84: Ethernet PHY Register Control - MR13 (EPHYREGCTL), address 0x00D

EPHYREGCTL (0x00D) and **EPHYADDAR** (0x00E) registers allow read/write access to the extended register set using indirect addressing. The modes for the **FUNC** field are as follows:

- **EPHYREGCTL[15:14] = 0x0**: A write to **EPHYADDAR** modifies the extended register set address register. This address register must be initialized in order to access any of the registers within the extended register set.
- **EPHYREGCTL[15:14] = 0x1**: A read/write to **EPHYADDAR** operates on the register within the extended register set selected (pointed to) by the value in the address register. The address register contents (pointer) remain unchanged.
- **EPHYREGCTL[15:14] = 0x2**: A read/write to **EPHYADDAR** operates on the register within the extended register set selected (pointed to) by the value in the address register. After that access is complete, for both reads and writes, the value in the address register is incremented.
- **EPHYREGCTL[15:14] = 0x3**: A read/write to **EPHYADDAR** operates on the register within the extended register set selected (pointed to) by the value in the address register. After that access is complete, for write accesses only, the value in the address register is incremented. For read accesses, the value of the address register remains unchanged.

This register is the MDIO Manageable Device (MMD) access control. In general, register **EPHYREGCTL [4:0]** is the device address, **DEVAD**, that directs any accesses of **EPHYADDAR** (0x00E) register to the appropriate MMD. It also contains selection bits for auto-increment of the data register. This register contains the device address to be written to access the extended registers. Write 0x1F into bits [4:0] of this register. It also contains selection bits [15:14] for the address auto-increment mode of **EPHYADDAR**.

Ethernet PHY Register Control - MR13 (EPHYREGCTL)

Base n/a
Address 0x00D
Type WO, reset 0x0000

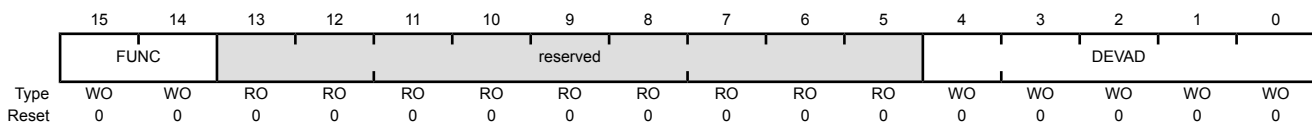

Bit/Field	Name	Type	Reset	Description
15:14	FUNC	WO	0	Function Value Description 0x0 Address 0x1 Data, no post increment 0x2 Data, post increment on read and write 0x3 Data, post increment on write only
13:5	reserved	RO	0	Software should not rely on the value of a reserved bit. To provide compatibility with future products, the value of a reserved bit should be preserved across a read-modify-write operation.

Bit/Field	Name	Type	Reset	Description
4:0	DEVAD	WO	0x0	Device Address In general, these bits [4:0] are the device address <code>DEVAD</code> that directs any accesses of EPHYADDAR register (0x00E) to the appropriate MMD. The PHY uses the vendor specific <code>DEVAD [4:0] = 0x1F</code> for accesses. All accesses through registers EPHYREGCR and EPHYADDAR should use this <code>DEVAD</code> . Transactions with other <code>DEVAD</code> are ignored.

Register 85: Ethernet PHY Address or Data - MR14 (EPHYADDR), address 0x00E

This register is the address/data MMD register. It is used in conjunction with **EPHYREGCTL** register (PHY offset 0x00D) to provide the access by an indirect read/write mechanism to the extended register set.

Ethernet PHY Address or Data - MR14 (EPHYADDR)

Base n/a

Address 0x00E

Type WO, reset 0x0000

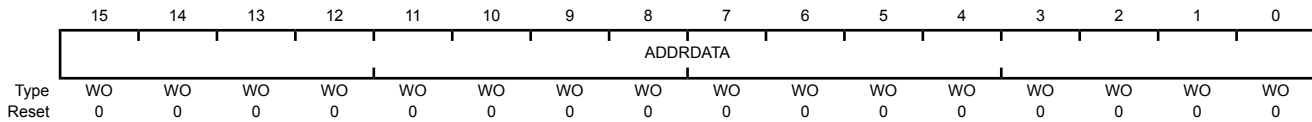

Bit/Field	Name	Type	Reset	Description
15:0	ADDRDATA	WO	0x0000	Address or Data

If the **EPHYREGCTL** register bits [15:14] = 0x0, this register holds the MDIO Manageable Device (MMD) DEVAD's address register, otherwise holds the MMD DEVAD's data register. See **EPHYREGCTL** register for more information about **DEVAD** field.

Register 86: Ethernet PHY Status - MR16 (EPHYSTS), address 0x010

This register provides quick access to commonly accessed PHY control status and general information.

Ethernet PHY Status - MR16 (EPHYSTS)

Base n/a
Address 0x010
Type RO, reset 0x0002

	15	14	13	12	11	10	9	8	7	6	5	4	3	2	1	0
	reserved	MDIXM	RXLERR	POLSTAT	FCSL	SD	DL	PAGERX	MIIREQ	RF	JD	ANS	MIILB	DUPLEX	SPEED	LINK
Type	RO	RO	RO	RO	RO	RO	RO	RO	RO	RO	RO	RO	RO	RO	RO	RO
Reset	0	0	0	0	0	0	0	0	0	0	0	0	0	0	1	0

Bit/Field	Name	Type	Reset	Description
15	reserved	RO	0	Software should not rely on the value of a reserved bit. To provide compatibility with future products, the value of a reserved bit should be preserved across a read-modify-write operation.
14	MDIXM	RO	0	MDI-X Mode This is a read-only status as reported by the Auto-Negotiation state machine: This bit is affected by the settings of the MDIXEN and FORCEMDIX bits in the EPHYCTL register. When MDIX is enabled, but not forced, this bit updates dynamically as the Auto-MDIX algorithm swaps between MDI and MDI-X configurations. Value Description 0 MDI pairs normal (Receive on TPRD pair, Transmit on TPTD pair) 1 MDI pairs swapped (Receive on TPTD pair, Transmit on TPRD pair)
13	RXLERR	RO	0	Receive Error Latch Value Description 0 No receive error event has occurred. 1 Receive error event has occurred since last read of EPHYRXERCNT register (PHY offset 0x015). This bit is cleared on a read of the EPHYRXERCNT register.
12	POLSTAT	RO	0	Polarity Status Value Description 0 Correct Polarity detected. 1 Inverted Polarity detected. This bit is a duplication of bit 4 (POLSTAT) in the EPHY10BTSC register (PHY offset 0x01A). This bit is cleared upon a read of the EPHY10BTSC register, but not on a read of the EPHYSTS register.

Bit/Field	Name	Type	Reset	Description
11	FCSL	RO	0	<p>False Carrier Sense Latch</p> <p>Value Description</p> <p>0 No False Carrier event has occurred.</p> <p>1 False Carrier event has occurred since last read of EPHYFCSCR register (0x014).</p> <p>This bit is cleared on a read of the EPHYFCSCR register.</p>
10	SD	RO	0	<p>Signal Detect</p> <p>This bit displays the active high 100Base-TX unconditional Signal Detect indication from the PMD (Physical Layer Medium Dependent).</p> <p>This bit is latched low and held until it is read, based upon the occurrence of the corresponding event.</p>
9	DL	RO	0	<p>Descrambler Lock</p> <p>This bit displays the active high 100Base-TX Descrambler Lock indication from PMD.</p> <p>This bit is latched low and held until it is read, based upon the occurrence of the corresponding event.</p>
8	PAGERX	RO	0	<p>Link Code Page Received</p> <p>Value Description</p> <p>0 Link Code Word Page has not been received.</p> <p>1 A new Link Code Word Page has been received. This is a duplicate of Page Received (bit 1) in the EPHYANER register and it is cleared on read of the EPHYANER register (0x006).</p> <p>This bit is not cleared upon a read of the EPHYSTS register.</p>
7	MIIREQ	RO	0	<p>MII Interrupt Pending</p> <p>Value Description</p> <p>0 No interrupt pending</p> <p>1 Indicates that an internal interrupt is pending. Interrupt source can be determined by reading the EPHYMISR1 Register (PHY offset 0x012). Reading the EPHYMISR1 clears this Interrupt bit indication.</p>
6	RF	RO	0	<p>Remote Fault</p> <p>Value Description</p> <p>0 No remote fault condition detected.</p> <p>1 Remote Fault condition detected. Criteria for a fault is when there is notification from Link Partner of Remote Fault via Auto-Negotiation. Cleared on read of EPHYBMSR register (PHY offset 0x001) or by reset.</p>

Bit/Field	Name	Type	Reset	Description
5	JD	RO	0	<p>Jabber Detect</p> <p>This bit will not be cleared upon a read of the EPHYSTS register.</p> <p>Value Description</p> <p>0 No Jabber.</p> <p>1 Jabber condition detected. This bit has meaning only in 10 Mb/s mode. This bit is a duplicate of the Jabber Detect bit in the EPHYBMSR register (PHY offset 0x001).</p>
4	ANS	RO	0	<p>Auto-Negotiation Status</p> <p>Value Description</p> <p>0 Auto-Negotiation not complete.</p> <p>1 Auto-Negotiation complete.</p>
3	MIILB	RO	0	<p>MII Loopback Status</p> <p>Value Description</p> <p>0 Normal operation.</p> <p>1 Loopback active (enabled).</p>
2	DUPLEX	RO	0	<p>Duplex Status</p> <p>Value Description</p> <p>0 Half Duplex Mode</p> <p>1 Full Duplex Mode</p> <p>This bit indicates duplex status and is determined from Auto-Negotiation or Forced Modes. Therefore, it is only valid if Auto-Negotiation is enabled and complete and there is a valid link or if Auto-Negotiation is disabled and there is a valid link.</p>
1	SPEED	RO	1	<p>Speed Status</p> <p>Value Description</p> <p>0 100 Mb/s mode.</p> <p>1 10 Mb/s mode.</p> <p>This bit indicates the status of the speed and is determined from Auto-Negotiation or Forced Modes. It is only valid if Auto-Negotiation is enabled and complete and there is a valid link or if Auto-Negotiation is disabled and there is a valid link.</p>
0	LINK	RO	0	<p>Link Status</p> <p>Value Description</p> <p>0 Link is not established.</p> <p>1 Valid link is established (for either 10 or 100 Mb/s operation). This bit is a duplicate of the Link Status bit in the EPHYBMSR register (PHY offset 0x001).</p> <p>This bit is not cleared upon a read of the EPHYSTS register.</p>

Register 87: Ethernet PHY Specific Control- MR17 (EPHYSCR), address 0x011

This register implements the PHY Specific Control register. This register allows access to general functionality inside the PHY to enable operation in reduced power modes and control the interrupt mechanism.

Ethernet PHY Specific Control- MR17 (EPHYSCR)

Base n/a
Address 0x011
Type RW, reset 0x0103

	15	14	13	12	11	10	9	8	7	6	5	4	3	2	1	0
	DISCLK	PSEN	PSMODE		SBPYASS	reserved	LBFIFO		reserved			COLFDM	reserved	TINT	INTEN	reserved
Type	RW	RW	RW	RW	RW	RO	RW	RW	RO	RO	RO	RW	RO	RW	RW	RO
Reset	0	0	0	0	1	0	0	0	0	0	0	0	0	0	1	0

Bit/Field	Name	Type	Reset	Description
15	DISCLK	RW	0	Disable CLK
				Value Description
				0 Normal mode of operation
				1 Disable internal clocks
				Clocks can be disabled only in IEEE power down mode.
14	PSEN	RW	0	Power Saving Modes Enable
				Value Description
				0 Normal mode of operation
				1 Enable power saving modes
13:12	PSMODE	RW	0	Power Saving Modes
				Value Description
				0x0 Normal: Normal operation mode. PHY is fully functional
				0x1 IEEE Power Down
				Low Power mode that shuts down all internal circuitry other than SMI functionality. Power could be dropped further by setting high DISCLK bit in this register and disabling internal clocks circuitries.
				0x2 Active Sleep
				Low Power Active Wake-On-LAN (WOL) mode that shuts down all internal circuitry other than SMI and energy detect functionality. In this mode the PHY sends NLP every 1.4 seconds to wake up the link-partner. Automatic power-up is done when link partner is detected.
				0x3 Passive Sleep
				Low Power WOL mode that shuts down all internal circuitry besides SMI and energy detect functionality. Automatic power-up is done when link partner is detected.

Bit/Field	Name	Type	Reset	Description
11	SBPYASS	RW	0x1	Scrambler Bypass Value Description 0 Scrambler bypass disabled. 1 Scrambler bypass enabled.
10	reserved	RO	0	Software should not rely on the value of a reserved bit. To provide compatibility with future products, the value of a reserved bit should be preserved across a read-modify-write operation.
9:8	LBFIFO	RW	0	Loopback FIFO Depth Value Description 0x0 Four nibble FIFO 0x1 Five nibble FIFO 0x2 Six nibble FIFO 0x3 Eight nibble FIFO This FIFO is used to adjust RX (recovered) clock rate to TX clock rate. FIFO depth must be set based on expected maximum packet size and clock accuracy. Default value sets to 5 nibbles.
7:5	reserved	RO	0	Software should not rely on the value of a reserved bit. To provide compatibility with future products, the value of a reserved bit should be preserved across a read-modify-write operation.
4	COLFDM	RW	0	Collision in Full-Duplex Mode Value Description 0 Disable collision indication in full-duplex mode. Collision indication is active in half-duplex mode only. 1 Enable collision signaling in full-duplex mode.
3	reserved	RO	0	Software should not rely on the value of a reserved bit. To provide compatibility with future products, the value of a reserved bit should be preserved across a read-modify-write operation.
2	TINT	RW	0	Test Interrupt Value Description 0 Do not generate interrupt 1 Generate an interrupt Forces the PHY to generate an interrupt to facilitate interrupt testing. Interrupts will continue to be generated as long as this bit remains set.

Bit/Field	Name	Type	Reset	Description
1	INTEN	RW	1	Interrupt Enable Value Description 0 Disable event based interrupts 1 Enable event based interrupts Enables interrupt dependent on the event enables in the EPHYMISR register (0x012).
0	reserved	RO	0	Software should not rely on the value of a reserved bit. To provide compatibility with future products, the value of a reserved bit should be preserved across a read-modify-write operation.

Register 88: Ethernet PHY MII Interrupt Status 1 - MR18 (EPHYMISR1), address 0x012

This register contains events status and enables for the interrupt function. If an event has occurred since the last read of this register, the corresponding status bit is set. If the corresponding enable bit in the register is set, an interrupt is generated if the event occurs. The `INTEN` bit (Bit 1) in the `EPHYSCR` register (0x011) must also be set to allow interrupts. The status indications in this register are set even if the interrupt is not enabled.

Ethernet PHY MII Interrupt Status 1 - MR18 (EPHYMISR1)

Base n/a
Address 0x012
Type RW, reset 0x0000

	15	14	13	12	11	10	9	8	7	6	5	4	3	2	1	0
	reserved		LINKSTAT	SPEED	DUPLEXM	ANC	FCHF	RXHF	reserved		LINKSTATEN	SPEEDEN	DUPLEXMEN	ANCEN	FCHFEN	RXHFEN
Type	RO	RO	RO	RO	RO	RO	RO	RO	RO	RO	RW	RW	RW	RW	RW	RW
Reset	0	0	0	0	0	0	0	0	0	0	0	0	0	0	0	0

Bit/Field	Name	Type	Reset	Description
15:14	reserved	RO	0	Software should not rely on the value of a reserved bit. To provide compatibility with future products, the value of a reserved bit should be preserved across a read-modify-write operation.
13	LINKSTAT	RO	0	Change of Link Status Interrupt Reading this bit clears the interrupt and thus, the status bit. Value Description 0 No change of link status. 1 Change of link status interrupt is pending.
12	SPEED	RO	0	Change of Speed Status Interrupt Reading this bit clears the interrupt and thus, the status bit. Value Description 0 No change of speed status. 1 Change of speed status interrupt is pending.
11	DUPLEXM	RO	0	Change of Duplex Status Interrupt Reading this bit clears the interrupt and thus, the status bit. Value Description 0 No change of duplex status. 1 Duplex status change interrupt is pending.
10	ANC	RO	0	Auto-Negotiation Complete Interrupt Reading this bit clears the interrupt and thus, the status bit. Value Description 0 No Auto-negotiation complete event is pending. 1 Auto-negotiation complete interrupt is pending.

Bit/Field	Name	Type	Reset	Description
9	FCHF	RO	0	False Carrier Counter Half-Full Interrupt Reading this bit clears the interrupt and thus, the status bit. Value Description 0 False carrier counter half-full event is not pending. 1 False carrier counter (Register EPHYFCSCR , address 0x014) exceeds half-full and an interrupt is pending.
8	RXHF	RO	0	Receive Error Counter Half-Full Interrupt Reading this bit clears the interrupt and thus, the status bit. Value Description 0 False carrier counter half-full event is not pending. 1 Receive error counter (Register EPHYRXERCNT , address 0x015) exceeds half-full and an interrupt is pending.
7:6	reserved	RO	0	Software should not rely on the value of a reserved bit. To provide compatibility with future products, the value of a reserved bit should be preserved across a read-modify-write operation.
5	LINKSTATEN	RW	0	Link Status Interrupt Enable Value Description 0 Change of link status interrupt disabled. 1 Enable interrupt on change of link status.
4	SPEEDEN	RW	0	Speed Change Interrupt Enable Value Description 0 Change of speed status interrupt disabled. 1 Enable interrupt on change of speed status
3	DUPLEXMEN	RW	0	Duplex Status Interrupt Enable Value Description 0 Change of duplex status interrupt disabled. 1 Enable interrupt on change of duplex status
2	ANCEN	RW	0	Auto-Negotiation Complete Interrupt Enable Value Description 0 Auto-negotiation complete interrupt disabled. 1 Enable interrupt on Auto-negotiation complete event

Bit/Field	Name	Type	Reset	Description
1	FCHFEN	RW	0	False Carrier Counter Register half-full Interrupt Enable Value Description 0 False Carrier Counter Register half-full interrupt disabled. 1 Enable interrupt on False Carrier Counter Register half-full event
0	RXHFEN	RW	0	Receive Error Counter Register Half-Full Event Interrupt Value Description 0 Receive Error Counter Register half-full interrupt disabled. 1 Enable interrupt on Receive Error Counter Register half-full event

Register 89: Ethernet PHY MII Interrupt Status 2 - MR19 (EPHYMISR2), address 0x013

This register contains additional event status and enables for the interrupt function. If an event has occurred since the last read of this register, the corresponding status bit is set. If the corresponding enable bit in the register is set, an interrupt is generated if the event occurs. The `INTEN` bit (bit 1) in the `EPHYSCR` register (PHY offset 0x011) must also be set to allow interrupts. The status indications in this register are set even if the interrupt is not enabled.

Ethernet PHY MII Interrupt Status 2 - MR19 (EPHYMISR2)

Base n/a
Address 0x013
Type RW, reset 0x0000

	15	14	13	12	11	10	9	8	7	6	5	4	3	2	1	0
	reserved	ANERR	PAGERX	LBFIFO	MDICO	SLEEP	POLINT	JABBER	reserved	ANERREN	PAGERXEN	LBFIFOEN	MDICOEN	SLEEPEN	POLINTEN	JABBEREN
Type	RO	RO	RO	RO	RO	RO	RO	RO	RO	RW	RW	RW	RW	RW	RW	RO
Reset	0	0	0	0	0	0	0	0	0	0	0	0	0	0	0	0

Bit/Field	Name	Type	Reset	Description
15	reserved	RO	0	Software should not rely on the value of a reserved bit. To provide compatibility with future products, the value of a reserved bit should be preserved across a read-modify-write operation.
14	ANERR	RO	0	Auto-Negotiation Error Interrupt Reading this bit clears the interrupt. Value Description 0 No Auto-negotiation error event pending. 1 Auto-negotiation error interrupt is pending.
13	PAGERX	RO	0	Page Receive Interrupt Reading this bit clears the interrupt. Value Description 0 Page has not been received. 1 Page has been received.
12	LBFIFO	RO	0	Loopback FIFO Overflow/Underflow Event Interrupt Reading this bit clears the interrupt. Value Description 0 No FIFO Overflow/Underflow event pending. 1 FIFO Overflow/Underflow event interrupt pending.
11	MDICO	RO	0	MDI/MDIX Crossover Status Changed Interrupt Reading this bit clears the interrupt. Value Description 0 MDI crossover status has not changed. 1 MDI crossover status changed interrupt is pending.

Bit/Field	Name	Type	Reset	Description
10	SLEEP	RO	0	<p>Sleep Mode Event Interrupt Reading this bit clears the interrupt.</p> <p>Value Description</p> <p>0 No sleep mode event pending.</p> <p>1 Sleep Mode event interrupt is pending.</p>
9	POLINT	RO	0	<p>Polarity Changed Interrupt Reading this bit clears the interrupt.</p> <p>Value Description</p> <p>0 No Data polarity event pending.</p> <p>1 Data polarity changed interrupt pending.</p>
8	JABBER	RO	0	<p>Jabber Detect Event Interrupt Reading this bit clears the interrupt.</p> <p>Value Description</p> <p>0 No Jabber detect event pending</p> <p>1 Jabber detect event interrupt pending.</p>
7	reserved	RO	0	Software should not rely on the value of a reserved bit. To provide compatibility with future products, the value of a reserved bit should be preserved across a read-modify-write operation.
6	ANERREN	RW	0	<p>Auto-Negotiation Error Interrupt Enable</p> <p>Value Description</p> <p>0 Auto-Negotiation error event interrupt disabled.</p> <p>1 Enable interrupt on Auto-Negotiation error event</p>
5	PAGERXEN	RW	0	<p>Page Receive Interrupt Enable</p> <p>Value Description</p> <p>0 Page Receive error event interrupt disabled.</p> <p>1 Page receive event interrupt enabled.</p>
4	LBFIFOEN	RW	0	<p>Loopback FIFO Overflow/Underflow Interrupt Enable</p> <p>Value Description</p> <p>0 Loopback FIFO overflow/underflow event interrupt disabled</p> <p>1 Loopback FIFO overflow/underflow event interrupt enabled.</p>

Bit/Field	Name	Type	Reset	Description
3	MDICOEN	RW	0	MDI/MDIX Crossover Status Changed Interrupt Enable Value Description 0 MDI/MDIX Crossover Change Status interrupt disabled 1 MDI/MDIX Crossover Change Status interrupt enabled.
2	SLEEPEN	RW	0	Sleep Mode Event Interrupt Enable Value Description 0 Sleep mode interrupt disabled. 1 Sleep Mode event interrupt enabled.
1	POLINTEN	RW	0	Polarity Changed Interrupt Enable Value Description 0 Polarity Change interrupt is disabled. 1 Polarity change interrupt is enabled.
0	JABBEREN	RO	0	Jabber Detect Event Interrupt Enable Value Description 0 Jabber detect interrupt disabled. 1 Jabber detect interrupt enabled.

Register 90: Ethernet PHY False Carrier Sense Counter - MR20 (EPHYFCSCR), address 0x014

This counter provides information required to implement the False Carriers attribute within the MAU managed object class of Clause 30 of the IEEE 802.3u specification.

Ethernet PHY False Carrier Sense Counter - MR20 (EPHYFCSCR)

Base n/a
 Address 0x014
 Type RO, reset 0x0000

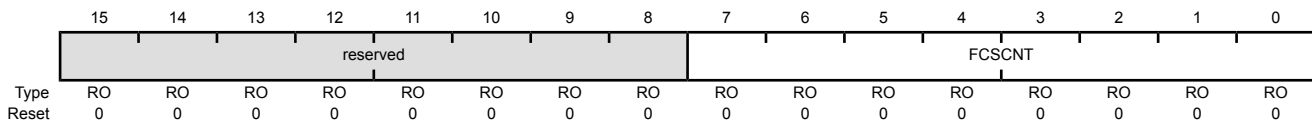

Bit/Field	Name	Type	Reset	Description
15:8	reserved	RO	0x0	Software should not rely on the value of a reserved bit. To provide compatibility with future products, the value of a reserved bit should be preserved across a read-modify-write operation.
7:0	FCSCNT	RO	0x00	False Carrier Event Counter This 8-bit counter increments on every false carrier event. This counter stops when it reaches its maximum count (0xFF). When the counter exceeds half full (0x7F), an interrupt event is generated. This register is cleared on read.

Register 91: Ethernet PHY Receive Error Count - MR21 (EPHYRXERCNT), address 0x015

This counter provides information required to implement the Symbol Error During Carrier attribute within the PHY managed object class of Clause 30 of the IEEE 802.3u specification.

Ethernet PHY Receive Error Count - MR21 (EPHYRXERCNT)

Base n/a

Address 0x015

Type RO, reset 0x0000.0000

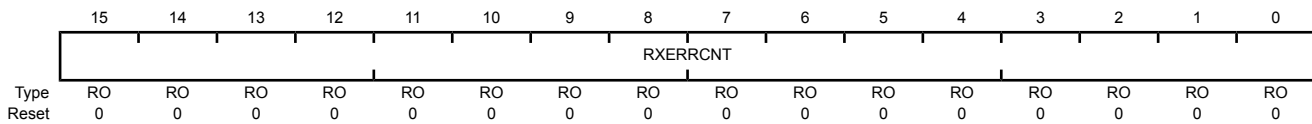

Bit/Field	Name	Type	Reset	Description
15:0	RXERRCNT	RO	0x0	Receive Error Count

15:0	RXERRCNT	RO	0x0	Receive Error Count
------	----------	----	-----	---------------------

When a valid carrier is present (while `EN0RXDV` is active), and there is at least one occurrence of an invalid data symbol, this 16-bit counter increments for each receive error detected. The **EPHYRXERCNT** counter does not count in MII loopback mode. The counter stops when it reaches its maximum count of 0xFFFF. When the counter exceeds half-full (0x7FFF), an interrupt is generated. This register is cleared on read.

Register 92: Ethernet PHY BIST Control - MR22 (EPHYBISTCR), address 0x016

This register is used for Build-In Self Test (BIST) configuration. The BIST functionality provides Pseudo Random Bit Stream (PRBS) mechanism including packet generation generator and checker. Selection of the exact loopback point in the signal chain is also done in this register.

Ethernet PHY BIST Control - MR22 (EPHYBISTCR)

Base n/a
Address 0x016
Type RW, reset 0x0100

	15	14	13	12	11	10	9	8	7	6	5	4	3	2	1	0
	reserved	PRBSM	PRBSPKT	PKTEN	PRBSCHCLK	PRBSCHKSYNC	PKTGENSTAT	PWRMODE	reserved	TXMIILB	reserved	LBMODE				
Type	RO	RW	RW	RW	RO	RO	RO	RO	RO	RO	RO	RW	RW	RW	RW	RW
Reset	0	0	0	0	0	0	0	1	0	0	0	0	0	0	0	0

Bit/Field	Name	Type	Reset	Description
15	reserved	RO	0	Software should not rely on the value of a reserved bit. To provide compatibility with future products, the value of a reserved bit should be preserved across a read-modify-write operation.
14	PRBSM	RW	0	PRBS Single/Continuous Mode Value Description 0 Single mode selected. When BIST Error Counter reaches its max value, the PRBS checker stops counting. 1 Continuous mode selected. When the PRBS counters reach maximum count value, the counter starts counting from zero again.
13	PRBSPKT	RW	0	Generated PRBS Packets Value Description 0 When packet generator is enabled, generate a single packet with constant data. PRBS generation and check is disabled. 1 When packet generator is enabled, generate continuous packets with PRBS data. When packet generator is disabled, PRBS checker is still enabled.
12	PKTEN	RW	0	Packet Generation Enable Value Description 0 Disable packet generator 1 Enable packet generation with PRBS data
11	PRBSCHCLK	RO	0	PRBS Checker Lock Indication Value Description 0 PRBS checker is not locked 1 PRBS checker is locked and synchronized on received bit stream

Bit/Field	Name	Type	Reset	Description
10	PRBSCHKSYNC	RO	0	PRBS Checker Lock Sync Loss Indication Value Description 0 PRBS checker has not lost synchronization. 1 PRBS checker has lost synchronization on received bit stream. This is an error indication.
9	PKTGENSTAT	RO	0	Packet Generator Status Indication Value Description 0 Packet Generator is disabled. 1 Packet Generator is active and generate packets.
8	PWRMODE	RO	1	Power Mode Indication Value Description 0 Indicates that the PHY is in one of the sleep modes, either active or passive. 1 Indicates that the PHY is in normal power mode.
7	reserved	RO	0	Software should not rely on the value of a reserved bit. To provide compatibility with future products, the value of a reserved bit should be preserved across a read-modify-write operation.
6	TXMIILB	RO	0	Transmit Data in MII Loopback Mode Value Description 0 Data is not transmitted to the line in MII loopback 1 Enable transmission of the data from the MAC received on the TX pins to the line in parallel to the MII loopback to RX pins. This bit may be set only in MII Loopback mode, which is enabled by setting the MIILLOOPBK bit in the EPHYBMCR register, offset EPHY.0x00.
5	reserved	RO	0	Software should not rely on the value of a reserved bit. To provide compatibility with future products, the value of a reserved bit should be preserved across a read-modify-write operation.

Bit/Field	Name	Type	Reset	Description																				
4:0	LBMODE	RW	0	Loopback Mode Select The PHY provides several options for Loopback that test and verify various functional blocks within the PHY. <table><thead><tr><th>Value</th><th>Description</th></tr></thead><tbody><tr><td>0x00</td><td>reserved</td></tr><tr><td>0x01</td><td>Near-end loopback: PCS Input Loopback</td></tr><tr><td>0x02</td><td>Near-end loopback: PCS Output Loopback (In 100Base-TX only)</td></tr><tr><td>0x03</td><td>reserved</td></tr><tr><td>0x04</td><td>Near-end loopback: Digital Loopback</td></tr><tr><td>0x05-0x07</td><td>reserved</td></tr><tr><td>0x08</td><td>Near-end loopback: Analog Loopback (requires 100Ω termination)</td></tr><tr><td>0x09-0x0F</td><td>reserved</td></tr><tr><td>0x10</td><td>Far-end Loopback: Reverse Loopback</td></tr></tbody></table>	Value	Description	0x00	reserved	0x01	Near-end loopback: PCS Input Loopback	0x02	Near-end loopback: PCS Output Loopback (In 100Base-TX only)	0x03	reserved	0x04	Near-end loopback: Digital Loopback	0x05-0x07	reserved	0x08	Near-end loopback: Analog Loopback (requires 100Ω termination)	0x09-0x0F	reserved	0x10	Far-end Loopback: Reverse Loopback
Value	Description																							
0x00	reserved																							
0x01	Near-end loopback: PCS Input Loopback																							
0x02	Near-end loopback: PCS Output Loopback (In 100Base-TX only)																							
0x03	reserved																							
0x04	Near-end loopback: Digital Loopback																							
0x05-0x07	reserved																							
0x08	Near-end loopback: Analog Loopback (requires 100Ω termination)																							
0x09-0x0F	reserved																							
0x10	Far-end Loopback: Reverse Loopback																							

Register 93: Ethernet PHY LED Control - MR24 (EPHYLEDCR), address 0x018

This register provides the ability to control the blink rate on the LED outputs.

Ethernet PHY LED Control - MR24 (EPHYLEDCR)

Base n/a

Address 0x018

Type RW, reset 0x0400

	15	14	13	12	11	10	9	8	7	6	5	4	3	2	1	0
	reserved					BLINKRATE		reserved								
Type	RO	RO	RO	RO	RO	RW	RW	RO	RO	RO	RO	RO	RO	RO	RO	RO
Reset	0	0	0	0	0	1	0	0	0	0	0	0	0	0	0	0

Bit/Field	Name	Type	Reset	Description										
15:11	reserved	RO	0	Software should not rely on the value of a reserved bit. To provide compatibility with future products, the value of a reserved bit should be preserved across a read-modify-write operation.										
10:9	BLINKRATE	RW	0x2	LED Blinking Rate (ON/OFF duration): <table border="0"> <tr> <td>Value</td> <td>Description</td> </tr> <tr> <td>0x0</td> <td>20 Hz (50 ms)</td> </tr> <tr> <td>0x1</td> <td>10 Hz (100 ms)</td> </tr> <tr> <td>0x2</td> <td>5 Hz (200 ms)</td> </tr> <tr> <td>0x3</td> <td>2 Hz (500 ms)</td> </tr> </table>	Value	Description	0x0	20 Hz (50 ms)	0x1	10 Hz (100 ms)	0x2	5 Hz (200 ms)	0x3	2 Hz (500 ms)
Value	Description													
0x0	20 Hz (50 ms)													
0x1	10 Hz (100 ms)													
0x2	5 Hz (200 ms)													
0x3	2 Hz (500 ms)													
8:0	reserved	RO	0	Software should not rely on the value of a reserved bit. To provide compatibility with future products, the value of a reserved bit should be preserved across a read-modify-write operation.										

Register 94: Ethernet PHY Control - MR25 (EPHYCTL), address 0x019

This register provides the ability to control and set general functionality inside the PHY.

Ethernet PHY Control - MR25 (EPHYCTL)

Base n/a

Address 0x019

Type RW, reset 0x8000

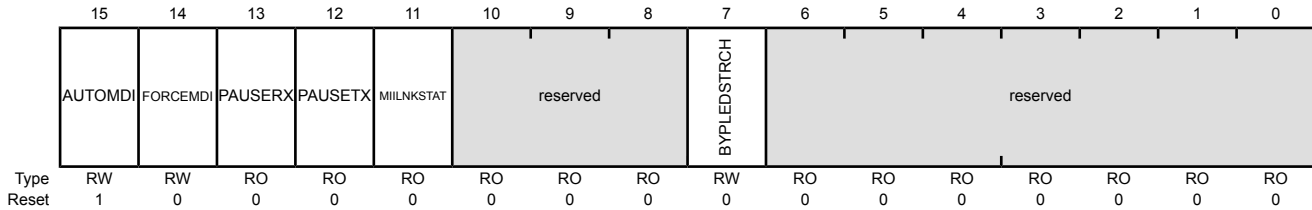

Bit/Field	Name	Type	Reset	Description
15	AUTOMDI	RW	1	Auto-MDIX Enable Value Description 0 Disable Auto- negotiation, Auto-MDIX capability. 1 Enable Auto-negotiation, Auto-MDIX capability.
14	FORCEMDI	RW	0	Force MDIX Value Description 0 Normal operation. (Transmit on TPTD pair, Receive on TPRD pair) 1 Force MDI pairs to cross. (Receive on TPTD pair, Transmit on TPRD pair)
13	PAUSERX	RO	0	Pause Receive Negotiated Status Value Description 0 No effect. 1 Indicates that pause receive should be enabled in the MAC. This bit is set based on bits [11:10] in the EPHYANA register and in the EPHYANLPAR register settings. This function is enabled according to IEEE 802.3 Annex 28B Table 28B-3, Pause Resolution, only if the Auto-Negotiated Highest Common Denominator is a full-duplex technology.
12	PAUSETX	RO	0	Pause Transmit Negotiated Status Value Description 0 No effect. 1 Indicates that pause transmit should be enabled in the MAC. This bit is set based on bits [11:10] in the EPHYANA register and in the EPHYANLPAR register settings. This function is enabled according to IEEE 802.3 Annex 28B Table 28B-3, Pause Resolution, only if the Auto-Negotiated Highest Common Denominator is a full-duplex technology.

Bit/Field	Name	Type	Reset	Description
11	MIILNKSTAT	RO	0	MII Link Status Value Description 0 No active link of 100BT full-duplex has been established using Auto-Negotiation. 1 100BT Full-duplex Link is active and was established using Auto-Negotiation.
10:8	reserved	RO	0	Software should not rely on the value of a reserved bit. To provide compatibility with future products, the value of a reserved bit should be preserved across a read-modify-write operation.
7	BYPLEDSTRCH	RW	0	Bypass LED Stretching This bypasses LED stretching and allows the LEDs to reflect normal operation values. Value Description 0 Normal LED operation. 1 Bypass LED stretching.
6:0	reserved	RO	0	Software should not rely on the value of a reserved bit. To provide compatibility with future products, the value of a reserved bit should be preserved across a read-modify-write operation.

Register 95: Ethernet PHY 10Base-T Status/Control - MR26 (EPHY10BTSC), address 0x01A

This register provides the ability to control and read status of the PHY's internal 10Base-T functionality.

Ethernet PHY 10Base-T Status/Control - MR26 (EPHY10BTSC)

Base n/a

Address 0x01A

Type RW, reset 0x0000

	15	14	13	12	11	10	9	8	7	6	5	4	3	2	1	0
	reserved		RXTHEN	SQUELCH				reserved	NLPDIS	reserved		POLSTAT	reserved		JABBERD	
Type	RO	RO	RW	RW	RW	RW	RW	RO	RW	RO	RO	RO	RO	RO	RO	RO
Reset	0	0	0	0	0	0	0	0	0	0	0	0	0	0	0	0

Bit/Field	Name	Type	Reset	Description
15:14	reserved	RO	0	Software should not rely on the value of a reserved bit. To provide compatibility with future products, the value of a reserved bit should be preserved across a read-modify-write operation.
13	RXTHEN	RW	0	Lower Receiver Threshold Enable Value Description 0 Normal 10Base-T operation. 1 Enable 10Base-T lower receiver threshold to allow operation with longer cables
12:9	SQUELCH	RW	0x0	Squelch Configuration Used to set the Peak Squelch ON threshold for the 10Base-T receiver. Every value corresponds to a 50-mV increase. The squelch threshold range is from 200 mV to 600 mV. The default Squelch threshold is set to 200 mV. Values 0xA to 0xF are reserved.
8	reserved	RO	0	Software should not rely on the value of a reserved bit. To provide compatibility with future products, the value of a reserved bit should be preserved across a read-modify-write operation.
7	NLPDIS	RW	0	Normal Link Pulse (NLP) Transmission Control Value Description 0 Enable transmission of Normal Link Pulses (NLPs). 1 Disable transmission of Normal Link Pulses (NLPs).
6:5	reserved	RO	0	Software should not rely on the value of a reserved bit. To provide compatibility with future products, the value of a reserved bit should be preserved across a read-modify-write operation.

Bit/Field	Name	Type	Reset	Description
4	POLSTAT	RO	0	<p>10 Mb Polarity Status</p> <p>This bit is a duplication of <code>POLSTAT</code> bit in the EPHYSTS register, offset 0x0010. Both bits are cleared on a read of the Ethernet PHY 10Base-T Status/Control (<code>EPHY10BTSC</code>), but not upon a read of the EPHYSTS register.</p> <p>Value Description</p> <p>0 Correct Polarity detected.</p> <p>1 Inverted Polarity detected.</p>
3:1	reserved	RO	0	<p>Software should not rely on the value of a reserved bit. To provide compatibility with future products, the value of a reserved bit should be preserved across a read-modify-write operation.</p>
0	JABBERD	RO	0	<p>Jabber Disable</p> <p>Note that this function is applicable only in 10Base-T.</p> <p>Value Description</p> <p>0 Jabber function enabled.</p> <p>1 Jabber function disabled.</p>

Register 96: Ethernet PHY BIST Control and Status 1 - MR27 (EPHYBICSR1), address 0x01B

This register provides the total number of error bytes that are received by the PRBS checker and defines the Inter-Packet Gap (IPG) for the packet generator.

Ethernet PHY BIST Control and Status 1 - MR27 (EPHYBICSR1)

Base n/a
 Address 0x01B
 Type RW, reset 0x007D

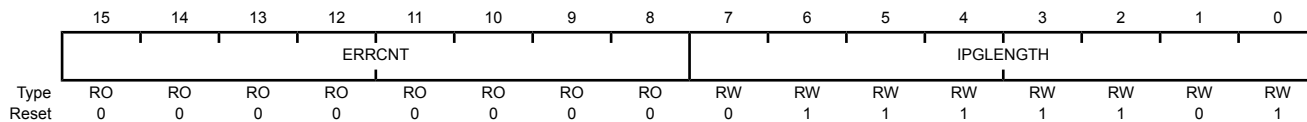

Bit/Field	Name	Type	Reset	Description
15:8	ERRCNT	RO	0x00	<p>BIST Error Count</p> <p>This field holds the number of erroneous bytes that were received by the PRBS checker. The value in this register is locked when a write is done to bit 15.</p> <p>When the PRBSM field in the EPHYBISCR register (0x0016) is set to zero, the count stops at 0xFF. See the EPHYBISCR register for further details.</p>
7:0	IPGLENGTH	RW	0x7D	<p>BIST IPG Length</p> <p>Inter Packet Gap (IPG) Length defines the size of the gap (in bytes) between any 2 successive packets generated by the BIST. Default value is 0x7D, which is equal to 125 bytes.</p>

Register 97: Ethernet PHY BIST Control and Status 2 - MR28 (EPHYBICSR2), address 0x01C

This register allows programming the length of the generated packets in bytes for the BIST mechanism

Ethernet PHY BIST Control and Status 2 - MR28 (EPHYBICSR2)

Base n/a

Address 0x01C

Type RW, reset 0x05EE

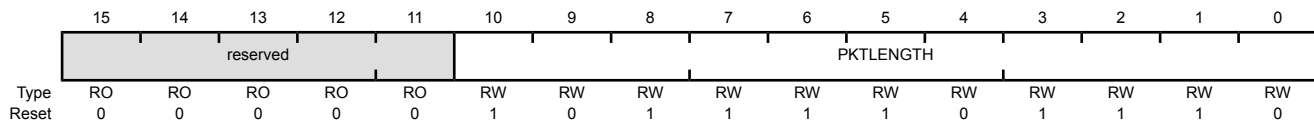

Bit/Field	Name	Type	Reset	Description
15:11	reserved	RO	0	Software should not rely on the value of a reserved bit. To provide compatibility with future products, the value of a reserved bit should be preserved across a read-modify-write operation.
10:0	PKTLENGTH	RW	0x5EE	BIST Packet Length The value of this register defines the size (in bytes) of every packet that is generated by the BIST. Default value is 0x5EE, which is equal to 1518 bytes.

Register 98: Ethernet PHY Cable Diagnostic Control - MR30 (EPHYCDRCR), address 0x01E

This register provides the ability to start cable diagnostics and monitor its status.

Ethernet PHY Cable Diagnostic Control - MR30 (EPHYCDRCR)

Base n/a

Address 0x01E

Type RO, reset 0x0102

	15	14	13	12	11	10	9	8	7	6	5	4	3	2	1	0
	START	reserved				LINKQUAL			reserved				DONE	FAIL		
Type	RW	RO	RO	RO	RO	RO	RO	RO	RO	RO	RO	RO	RO	RO	RO	RO
Reset	0	0	0	0	0	0	0	1	0	0	0	0	0	0	1	0

Bit/Field	Name	Type	Reset	Description
15	START	RW	0	<p>Cable Diagnostic Process Start</p> <p>Diagnostic Start bit is cleared with raise of Diagnostic Done indication.</p> <p>Value Description</p> <p>0 Cable Diagnostic is disabled</p> <p>1 Start cable diagnostic measurement</p>
14:10	reserved	RO	0	<p>Software should not rely on the value of a reserved bit. To provide compatibility with future products, the value of a reserved bit should be preserved across a read-modify-write operation.</p>
9:8	LINKQUAL	RO	0x1	<p>Link Quality Indication</p> <p>The value of these bits are valid only when link is active (when the <code>LINK</code> bit in the <code>EPHYSTS</code> register is a 0x1).</p> <p>Value Description</p> <p>0x0 reserved</p> <p>0x1 Good Quality Link Indication</p> <p>0x2 Mid- Quality Link Indication</p> <p>0x3 Poor Quality Link Indication</p>
7:2	reserved	RO	0	<p>Software should not rely on the value of a reserved bit. To provide compatibility with future products, the value of a reserved bit should be preserved across a read-modify-write operation.</p>
1	DONE	RO	1	<p>Cable Diagnostic Process Done</p> <p>Value Description</p> <p>0 Diagnostic has not completed</p> <p>1 Indicates that the cable measurement process completed</p>
0	FAIL	RO	0	<p>Cable Diagnostic Process Fail</p> <p>Value Description</p> <p>0 Diagnostic has not failed</p> <p>1 Indicates that the cable measurement process failed</p>

Register 99: Ethernet PHY Reset Control - MR31 (EPHYRCR), address 0x01F

This register allows the system to reset or restart the PHY by register access.

Ethernet PHY Reset Control - MR31 (EPHYRCR)

Base n/a

Address 0x01F

Type RW, reset 0x0000

	15	14	13	12	11	10	9	8	7	6	5	4	3	2	1	0
	SWRST	SWRESTART	reserved													
Type	RW	RW	RO	RO	RO	RO	RO	RO	RO	RO	RO	RO	RO	RO	RO	RO
Reset	0	0	0	0	0	0	0	0	0	0	0	0	0	0	0	0

Bit/Field	Name	Type	Reset	Description
15	SWRST	RW	0	Software Reset Value Description 0 Normal Operation. 1 Soft reset. This mode resets the digital portion of the PHY and all of the registers. This bit self clears after completion.
14	SWRESTART	RW	0	Software Restart Value Description 0 Normal Operation. 1 Restart PHY. This mode resets the digital portion of the PHY but no the registers. This bit self clears after completion of the restart.
13:0	reserved	RO	0	Software should not rely on the value of a reserved bit. To provide compatibility with future products, the value of a reserved bit should be preserved across a read-modify-write operation.

Register 100: Ethernet PHY LED Configuration - MR37 (EPHYLEDCFG), address 0x025

This register configures the LEDs provided in the PHY.

Ethernet PHY LED Configuration - MR37 (EPHYLEDCFG)

Base n/a
 Address 0x025
 Type RW, reset 0x0000.0510

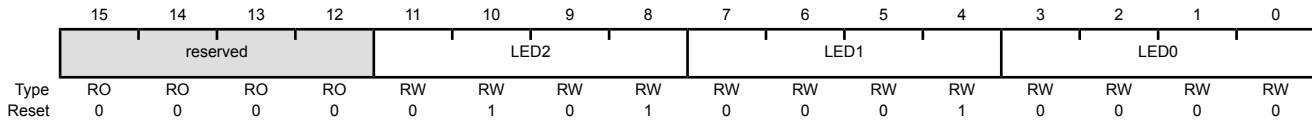

Bit/Field	Name	Type	Reset	Description																						
15:12	reserved	RO	0	Software should not rely on the value of a reserved bit. To provide compatibility with future products, the value of a reserved bit should be preserved across a read-modify-write operation.																						
11:8	LED2	RW	0x5	<p>LED2 Configuration</p> <p>The following encodings are used to program the specific function desired for the LED.</p> <table border="1"> <thead> <tr> <th>Value</th> <th>Description</th> </tr> </thead> <tbody> <tr><td>0x0</td><td>Link OK</td></tr> <tr><td>0x1</td><td>RX/TX Activity</td></tr> <tr><td>0x2</td><td>TX Activity</td></tr> <tr><td>0x3</td><td>RX Activity</td></tr> <tr><td>0x4</td><td>Collision</td></tr> <tr><td>0x5</td><td>100-Base TX</td></tr> <tr><td>0x6</td><td>10-Base TX</td></tr> <tr><td>0x7</td><td>Full Duplex</td></tr> <tr><td>0x8</td><td>Link OK/Blink on TX/RX Activity</td></tr> <tr><td>0x9-0xF</td><td>Reserved</td></tr> </tbody> </table>	Value	Description	0x0	Link OK	0x1	RX/TX Activity	0x2	TX Activity	0x3	RX Activity	0x4	Collision	0x5	100-Base TX	0x6	10-Base TX	0x7	Full Duplex	0x8	Link OK/Blink on TX/RX Activity	0x9-0xF	Reserved
Value	Description																									
0x0	Link OK																									
0x1	RX/TX Activity																									
0x2	TX Activity																									
0x3	RX Activity																									
0x4	Collision																									
0x5	100-Base TX																									
0x6	10-Base TX																									
0x7	Full Duplex																									
0x8	Link OK/Blink on TX/RX Activity																									
0x9-0xF	Reserved																									
7:4	LED1	RW	0x1	<p>LED1 Configuration</p> <p>The following encodings are used to program the specific function desired for the LED.</p> <table border="1"> <thead> <tr> <th>Value</th> <th>Description</th> </tr> </thead> <tbody> <tr><td>0x0</td><td>Link OK</td></tr> <tr><td>0x1</td><td>RX/TX Activity</td></tr> <tr><td>0x2</td><td>TX Activity</td></tr> <tr><td>0x3</td><td>RX Activity</td></tr> <tr><td>0x4</td><td>Collision</td></tr> <tr><td>0x5</td><td>100-Base TX</td></tr> <tr><td>0x6</td><td>10-Base TX</td></tr> <tr><td>0x7</td><td>Full Duplex</td></tr> <tr><td>0x8</td><td>Link OK/Blink on TX/RX Activity</td></tr> <tr><td>0x9-0xF</td><td>Reserved</td></tr> </tbody> </table>	Value	Description	0x0	Link OK	0x1	RX/TX Activity	0x2	TX Activity	0x3	RX Activity	0x4	Collision	0x5	100-Base TX	0x6	10-Base TX	0x7	Full Duplex	0x8	Link OK/Blink on TX/RX Activity	0x9-0xF	Reserved
Value	Description																									
0x0	Link OK																									
0x1	RX/TX Activity																									
0x2	TX Activity																									
0x3	RX Activity																									
0x4	Collision																									
0x5	100-Base TX																									
0x6	10-Base TX																									
0x7	Full Duplex																									
0x8	Link OK/Blink on TX/RX Activity																									
0x9-0xF	Reserved																									

Bit/Field	Name	Type	Reset	Description																						
3:0	LED0	RW	0x0	LED0 Configuration The following encodings are used to program the specific function desired for the LED. <table><thead><tr><th>Value</th><th>Description</th></tr></thead><tbody><tr><td>0x0</td><td>Link OK</td></tr><tr><td>0x1</td><td>RX/TX Activity</td></tr><tr><td>0x2</td><td>TX Activity</td></tr><tr><td>0x3</td><td>RX Activity</td></tr><tr><td>0x4</td><td>Collision</td></tr><tr><td>0x5</td><td>100-Base TX</td></tr><tr><td>0x6</td><td>10-Base TX</td></tr><tr><td>0x7</td><td>Full Duplex</td></tr><tr><td>0x8</td><td>Link OK/Blink on TX/RX Activity</td></tr><tr><td>0x9-0xF</td><td>Reserved</td></tr></tbody></table>	Value	Description	0x0	Link OK	0x1	RX/TX Activity	0x2	TX Activity	0x3	RX Activity	0x4	Collision	0x5	100-Base TX	0x6	10-Base TX	0x7	Full Duplex	0x8	Link OK/Blink on TX/RX Activity	0x9-0xF	Reserved
Value	Description																									
0x0	Link OK																									
0x1	RX/TX Activity																									
0x2	TX Activity																									
0x3	RX Activity																									
0x4	Collision																									
0x5	100-Base TX																									
0x6	10-Base TX																									
0x7	Full Duplex																									
0x8	Link OK/Blink on TX/RX Activity																									
0x9-0xF	Reserved																									

24 Universal Serial Bus (USB) Controller

Important: The full USB chapter is under NDA. This chapter describes the module features at a high level. For a copy of the full NDA data sheet, follow the instructions in the *Non-Disclosure Agreement for the Tiva C Series TM4C129ENC PDT Microcontroller Data Sheet* (literature number [SPMS418](#)).

The TM4C129ENC PDT USB controller operates as a full-speed or low-speed function controller during point-to-point communications with USB Host, Device, or OTG functions. If the integrated ULPI interface is utilized, the USB can operate at high-speed. The controller complies with the USB 2.0 standard, which includes SUSPEND and RESUME signaling. 16 endpoints including two hard-wired for control transfers (one endpoint for IN and one endpoint for OUT) plus 14 endpoints defined by firmware along with a dynamic sizable FIFO support multiple packet queueing. USB DMA access to the FIFO allows minimal interference from system software. Software-controlled connect and disconnect allows flexibility during USB device start-up. The controller complies with OTG Standard's Session Request Protocol (SRP) and Host Negotiation Protocol (HNP).

The TM4C129ENC PDT USB module has the following features:

- Complies with USB-IF (Implementer's Forum) certification standards
- USB 2.0 high-speed (480 Mbps) operation with the integrated ULPI interface communicating with an external PHY
- Link Power Management support which uses link-state awareness to reduce power usage
- 4 transfer types: Control, Interrupt, Bulk, and Isochronous
- 16 endpoints
 - 1 dedicated control IN endpoint and 1 dedicated control OUT endpoint
 - 7 configurable IN endpoints and 7 configurable OUT endpoints
- 4 KB dedicated endpoint memory: one endpoint may be defined for double-buffered 1023-byte isochronous packet size
- VBUS droop detection and interrupt
- Integrated USB DMA with bus master capability
 - Up to eight RX Endpoint channels and up to eight TX Endpoint channels are available.
 - Each channel can be separately programmed to operate in different modes
 - Incremental burst transfers of 4-, 8-, 16- or unspecified length supported

24.1 Block Diagram

Figure 24-1. USB Module Block Diagram

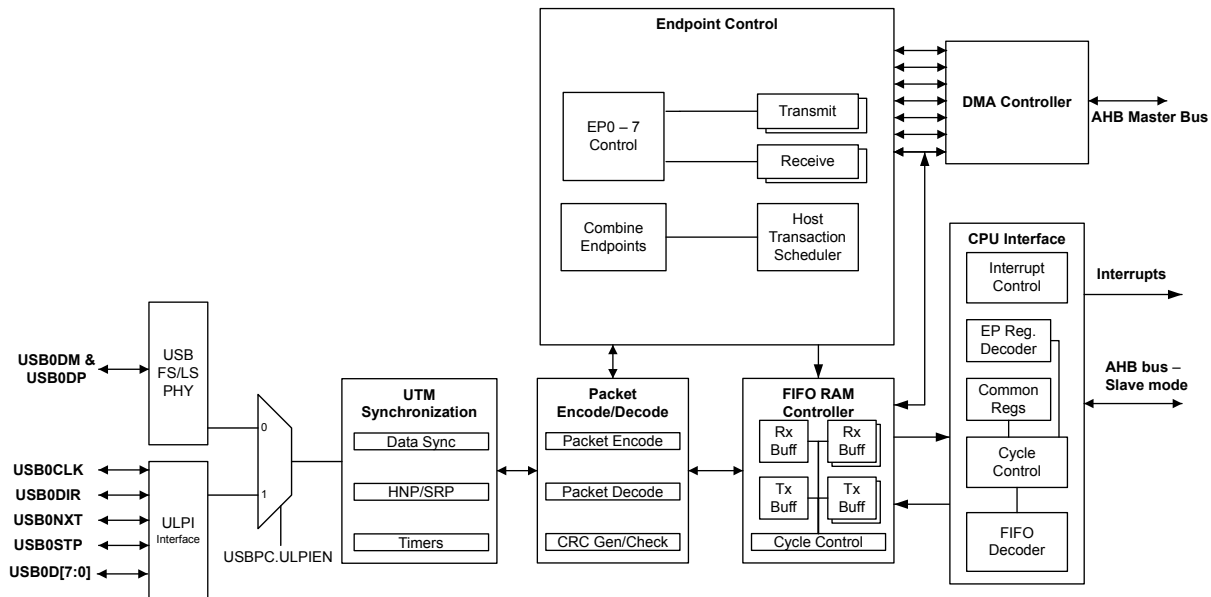

24.2 Signal Description

The following table lists the external signals of the USB controller and describes the function of each. Some USB controller signals are alternate functions for some GPIO signals and default to be GPIO signals at reset. The column in the table below titled "Pin Mux/Pin Assignment" lists the possible GPIO pin placements for these USB signals. The `AFSEL` bit in the **GPIO Alternate Function Select (GPIOAFSEL)** register (page 778) should be set to choose the USB function. The number in parentheses is the encoding that must be programmed into the `PMCn` field in the **GPIO Port Control (GPIOPCTL)** register (page 795) to assign the USB signal to the specified GPIO port pin. The `USB0VBUS` and `USB0ID` signals are configured by clearing the appropriate `DEN` bit in the **GPIO Digital Enable (GPIODEN)** register. For more information on configuring GPIOs, see "General-Purpose Input/Outputs (GPIOs)" on page 750. The remaining signals (with the word "fixed" in the Pin Mux/Pin Assignment column) have a fixed pin assignment and function.

Note: When used in OTG mode, `USB0VBUS` and `USB0ID` do not require any configuration as they are dedicated pins for the USB controller and directly connect to the USB connector's VBUS and ID signals. If the USB controller is used as either a dedicated Host or Device, the `DEVMOD` field in the **USB General-Purpose Control and Status (USBGPCS)** register can be used to connect the `USB0VBUS` and/or `USB0ID` inputs to fixed levels internally, freeing the `PB0` and `PB1` pins for GPIO use. Note that `PB1` (`USB0VBUS`) is a 5-V tolerant signal as required. For proper self-powered Device operation, the VBUS value must still be monitored to assure that if the Host removes VBUS, the self-powered Device disables the D+/D- pull-up resistors. This function can be accomplished by connecting a standard GPIO to VBUS.

The termination resistors for the USB PHY have been added internally, and thus there is no need for external resistors. For a device, there is a 1.5 KOhm pull-up on the D+ and for a host there are 15 KOhm pull-downs on both D+ and D-.

Note: Port pins $PL6$ and $PL7$ operate as Fast GPIO pads, but have 4-mA drive capability only. GPIO register controls for drive strength, slew rate and open drain have no effect on these pins. The registers which have no effect are as follows: **GPIODR2R**, **GPIODR4R**, **GPIODR8R**, **GPIODR12R**, **GPIOSLR**, and **GPIOODR**. Refer to “General-Purpose Input/Outputs (GPIOs)” on page 750 and “Recommended GPIO Operating Characteristics” on page 1944 for more information.

Table 24-1. USB Signals (128TQFP)

Pin Name	Pin Number	Pin Mux / Pin Assignment	Pin Type	Buffer Type	Description
USB0CLK	92	PB3 (14)	O	TTL	60-MHz clock to the external PHY.
USB0D0	81	PL0 (14)	I/O	TTL	USB data 0.
USB0D1	82	PL1 (14)	I/O	TTL	USB data 1.
USB0D2	83	PL2 (14)	I/O	TTL	USB data 2.
USB0D3	84	PL3 (14)	I/O	TTL	USB data 3.
USB0D4	85	PL4 (14)	I/O	TTL	USB data 4.
USB0D5	86	PL5 (14)	I/O	TTL	USB data 5.
USB0D6	106	PP5 (14)	I/O	TTL	USB data 6.
USB0D7	105	PP4 (14)	I/O	TTL	USB data 7.
USB0DIR	104	PP3 (14)	O	TTL	Indicates that the external PHY is able to accept data from the USB controller.
USB0DM	93	PL7	I/O	Analog	Bidirectional differential data pin (D- per USB specification) for USB0.
USB0DP	94	PL6	I/O	Analog	Bidirectional differential data pin (D+ per USB specification) for USB0.
USB0EPEN	40 41 127	PA6 (5) PA7 (11) PD6 (5)	O	TTL	Optionally used in Host mode to control an external power source to supply power to the USB bus.
USB0ID	95	PB0	I	Analog	This signal senses the state of the USB ID signal. The USB PHY enables an integrated pull-up, and an external element (USB connector) indicates the initial state of the USB controller (pulled down is the A side of the cable and pulled up is the B side).
USB0NXT	103	PP2 (14)	O	TTL	Asserted by the external PHY to throttle all data types.
USB0PFLT	41 128	PA7 (5) PD7 (5)	I	TTL	Optionally used in Host mode by an external power source to indicate an error state by that power source.
USB0STP	91	PB2 (14)	O	TTL	Asserted by the USB controller to signal the end of a USB transmit packet or register write operation.
USB0VBUS	96	PB1	I/O	Analog	This signal is used during the session request protocol. This signal allows the USB PHY to both sense the voltage level of VBUS, and pull up VBUS momentarily during VBUS pulsing.

24.3 Register Map

Table 24-2 on page 1771 lists the registers. All addresses given are relative to the USB base address of 0x4005.0000. Note that the USB controller clock must be enabled before the registers can be programmed (see page 400). There must be a delay of 3 system clocks after the USB module clock is enabled before any USB module registers are accessed.

Note: Descriptions for all these registers can be found in the NDA version of the data sheet.

Table 24-2. List of Registers

Offset	Name	Description
0x000	USBFADDR	USB Device Functional Address
0x001	USBPOWER	USB Power
0x002	USBTXIS	USB Transmit Interrupt Status
0x004	USBRXIS	USB Receive Interrupt Status
0x006	USBTXIE	USB Transmit Interrupt Enable
0x008	USBRXIE	USB Receive Interrupt Enable
0x00A	USBIS	USB General Interrupt Status
0x00B	USBIE	USB Interrupt Enable
0x00C	USBFRAME	USB Frame Value
0x00E	USBEPIDX	USB Endpoint Index
0x00F	USBTTEST	USB Test Mode
0x020	USBFIFO0	USB FIFO Endpoint 0
0x024	USBFIFO1	USB FIFO Endpoint 1
0x028	USBFIFO2	USB FIFO Endpoint 2
0x02C	USBFIFO3	USB FIFO Endpoint 3
0x030	USBFIFO4	USB FIFO Endpoint 4
0x034	USBFIFO5	USB FIFO Endpoint 5
0x038	USBFIFO6	USB FIFO Endpoint 6
0x03C	USBFIFO7	USB FIFO Endpoint 7
0x060	USBDEVCTL	USB Device Control
0x061	USBCCONF	USB Common Configuration
0x062	USBTXFIFOSZ	USB Transmit Dynamic FIFO Sizing
0x063	USBRXFIFOSZ	USB Receive Dynamic FIFO Sizing
0x064	USBTXFIFOADD	USB Transmit FIFO Start Address
0x066	USBRXFIFOADD	USB Receive FIFO Start Address
0x070	ULPIVBUSCTL	USB ULPI VBUS Control
0x074	ULPIREGDATA	USB ULPI Register Data
0x075	ULPIREGADDR	USB ULPI Register Address
0x076	ULPIREGCTL	USB ULPI Register Control
0x078	USBEPINFO	USB Endpoint Information
0x079	USBRAMINFO	USB RAM Information
0x07A	USBCONTIM	USB Connect Timing
0x07B	USBVPLEN	USB OTG VBUS Pulse Timing
0x07C	USBHSEOF	USB High-Speed Last Transaction to End of Frame Timing
0x07D	USBFSEOF	USB Full-Speed Last Transaction to End of Frame Timing
0x07E	USBLSEOF	USB Low-Speed Last Transaction to End of Frame Timing
0x080	USBTXFUNCADDR0	USB Transmit Functional Address Endpoint 0
0x082	USBTXHUBADDR0	USB Transmit Hub Address Endpoint 0
0x083	USBTXHUBPORT0	USB Transmit Hub Port Endpoint 0
0x088	USBTXFUNCADDR1	USB Transmit Functional Address Endpoint 1

Table 24-2. List of Registers (continued)

Offset	Name	Description
0x08A	USBTXHUBADDR1	USB Transmit Hub Address Endpoint 1
0x08B	USBTXHUBPORT1	USB Transmit Hub Port Endpoint 1
0x08C	USBRXFUNCADDR1	USB Receive Functional Address Endpoint 1
0x08E	USBRXHUBADDR1	USB Receive Hub Address Endpoint 1
0x08F	USBRXHUBPORT1	USB Receive Hub Port Endpoint 1
0x090	USBTXFUNCADDR2	USB Transmit Functional Address Endpoint 2
0x092	USBTXHUBADDR2	USB Transmit Hub Address Endpoint 2
0x093	USBTXHUBPORT2	USB Transmit Hub Port Endpoint 2
0x094	USBRXFUNCADDR2	USB Receive Functional Address Endpoint 2
0x096	USBRXHUBADDR2	USB Receive Hub Address Endpoint 2
0x097	USBRXHUBPORT2	USB Receive Hub Port Endpoint 2
0x098	USBTXFUNCADDR3	USB Transmit Functional Address Endpoint 3
0x09A	USBTXHUBADDR3	USB Transmit Hub Address Endpoint 3
0x09B	USBTXHUBPORT3	USB Transmit Hub Port Endpoint 3
0x09C	USBRXFUNCADDR3	USB Receive Functional Address Endpoint 3
0x09E	USBRXHUBADDR3	USB Receive Hub Address Endpoint 3
0x09F	USBRXHUBPORT3	USB Receive Hub Port Endpoint 3
0x0A0	USBTXFUNCADDR4	USB Transmit Functional Address Endpoint 4
0x0A2	USBTXHUBADDR4	USB Transmit Hub Address Endpoint 4
0x0A3	USBTXHUBPORT4	USB Transmit Hub Port Endpoint 4
0x0A4	USBRXFUNCADDR4	USB Receive Functional Address Endpoint 4
0x0A6	USBRXHUBADDR4	USB Receive Hub Address Endpoint 4
0x0A7	USBRXHUBPORT4	USB Receive Hub Port Endpoint 4
0x0A8	USBTXFUNCADDR5	USB Transmit Functional Address Endpoint 5
0x0AA	USBTXHUBADDR5	USB Transmit Hub Address Endpoint 5
0x0AB	USBTXHUBPORT5	USB Transmit Hub Port Endpoint 5
0x0AC	USBRXFUNCADDR5	USB Receive Functional Address Endpoint 5
0x0AE	USBRXHUBADDR5	USB Receive Hub Address Endpoint 5
0x0AF	USBRXHUBPORT5	USB Receive Hub Port Endpoint 5
0x0B0	USBTXFUNCADDR6	USB Transmit Functional Address Endpoint 6
0x0B2	USBTXHUBADDR6	USB Transmit Hub Address Endpoint 6
0x0B3	USBTXHUBPORT6	USB Transmit Hub Port Endpoint 6
0x0B4	USBRXFUNCADDR6	USB Receive Functional Address Endpoint 6
0x0B6	USBRXHUBADDR6	USB Receive Hub Address Endpoint 6
0x0B7	USBRXHUBPORT6	USB Receive Hub Port Endpoint 6
0x0B8	USBTXFUNCADDR7	USB Transmit Functional Address Endpoint 7
0x0BA	USBTXHUBADDR7	USB Transmit Hub Address Endpoint 7
0x0BB	USBTXHUBPORT7	USB Transmit Hub Port Endpoint 7
0x0BC	USBRXFUNCADDR7	USB Receive Functional Address Endpoint 7
0x0BE	USBRXHUBADDR7	USB Receive Hub Address Endpoint 7
0x0BF	USBRXHUBPORT7	USB Receive Hub Port Endpoint 7
0x102	USBCSRL0	USB Control and Status Endpoint 0 Low

Table 24-2. List of Registers (continued)

Offset	Name	Description
0x103	USBCSRH0	USB Control and Status Endpoint 0 High
0x108	USBCOUNT0	USB Receive Byte Count Endpoint 0
0x10A	USBTYPE0	USB Type Endpoint 0
0x10B	USBNAKLMT	USB NAK Limit
0x110	USBTXMAXP1	USB Maximum Transmit Data Endpoint 1
0x112	USBTXCSSL1	USB Transmit Control and Status Endpoint 1 Low
0x113	USBTXCSSL1	USB Transmit Control and Status Endpoint 1 High
0x114	USBRXMAXP1	USB Maximum Receive Data Endpoint 1
0x116	USBRXCSSL1	USB Receive Control and Status Endpoint 1 Low
0x117	USBRXCSSL1	USB Receive Control and Status Endpoint 1 High
0x118	USBRXCOUNT1	USB Receive Byte Count Endpoint 1
0x11A	USBTXTYPE1	USB Host Transmit Configure Type Endpoint 1
0x11B	USBTXINTERVAL1	USB Host Transmit Interval Endpoint 1
0x11C	USBRXTYPE1	USB Host Configure Receive Type Endpoint 1
0x11D	USBRXINTERVAL1	USB Host Receive Polling Interval Endpoint 1
0x120	USBTXMAXP2	USB Maximum Transmit Data Endpoint 2
0x122	USBTXCSSL2	USB Transmit Control and Status Endpoint 2 Low
0x123	USBTXCSSL2	USB Transmit Control and Status Endpoint 2 High
0x124	USBRXMAXP2	USB Maximum Receive Data Endpoint 2
0x126	USBRXCSSL2	USB Receive Control and Status Endpoint 2 Low
0x127	USBRXCSSL2	USB Receive Control and Status Endpoint 2 High
0x128	USBRXCOUNT2	USB Receive Byte Count Endpoint 2
0x12A	USBTXTYPE2	USB Host Transmit Configure Type Endpoint 2
0x12B	USBTXINTERVAL2	USB Host Transmit Interval Endpoint 2
0x12C	USBRXTYPE2	USB Host Configure Receive Type Endpoint 2
0x12D	USBRXINTERVAL2	USB Host Receive Polling Interval Endpoint 2
0x130	USBTXMAXP3	USB Maximum Transmit Data Endpoint 3
0x132	USBTXCSSL3	USB Transmit Control and Status Endpoint 3 Low
0x133	USBTXCSSL3	USB Transmit Control and Status Endpoint 3 High
0x134	USBRXMAXP3	USB Maximum Receive Data Endpoint 3
0x136	USBRXCSSL3	USB Receive Control and Status Endpoint 3 Low
0x137	USBRXCSSL3	USB Receive Control and Status Endpoint 3 High
0x138	USBRXCOUNT3	USB Receive Byte Count Endpoint 3
0x13A	USBTXTYPE3	USB Host Transmit Configure Type Endpoint 3
0x13B	USBTXINTERVAL3	USB Host Transmit Interval Endpoint 3
0x13C	USBRXTYPE3	USB Host Configure Receive Type Endpoint 3
0x13D	USBRXINTERVAL3	USB Host Receive Polling Interval Endpoint 3
0x140	USBTXMAXP4	USB Maximum Transmit Data Endpoint 4
0x142	USBTXCSSL4	USB Transmit Control and Status Endpoint 4 Low
0x143	USBTXCSSL4	USB Transmit Control and Status Endpoint 4 High
0x144	USBRXMAXP4	USB Maximum Receive Data Endpoint 4
0x146	USBRXCSSL4	USB Receive Control and Status Endpoint 4 Low

Table 24-2. List of Registers (continued)

Offset	Name	Description
0x147	USBRXCSRH4	USB Receive Control and Status Endpoint 4 High
0x148	USBRXCOUNT4	USB Receive Byte Count Endpoint 4
0x14A	USBTXTYPE4	USB Host Transmit Configure Type Endpoint 4
0x14B	USBTXINTERVAL4	USB Host Transmit Interval Endpoint 4
0x14C	USBRXTYPE4	USB Host Configure Receive Type Endpoint 4
0x14D	USBRXINTERVAL4	USB Host Receive Polling Interval Endpoint 4
0x150	USBTXMAXP5	USB Maximum Transmit Data Endpoint 5
0x152	USBTXCURL5	USB Transmit Control and Status Endpoint 5 Low
0x153	USBTXCSRH5	USB Transmit Control and Status Endpoint 5 High
0x154	USBRXMAXP5	USB Maximum Receive Data Endpoint 5
0x156	USBRXCURL5	USB Receive Control and Status Endpoint 5 Low
0x157	USBRXCSRH5	USB Receive Control and Status Endpoint 5 High
0x158	USBRXCOUNT5	USB Receive Byte Count Endpoint 5
0x15A	USBTXTYPE5	USB Host Transmit Configure Type Endpoint 5
0x15B	USBTXINTERVAL5	USB Host Transmit Interval Endpoint 5
0x15C	USBRXTYPE5	USB Host Configure Receive Type Endpoint 5
0x15D	USBRXINTERVAL5	USB Host Receive Polling Interval Endpoint 5
0x160	USBTXMAXP6	USB Maximum Transmit Data Endpoint 6
0x162	USBTXCURL6	USB Transmit Control and Status Endpoint 6 Low
0x163	USBTXCSRH6	USB Transmit Control and Status Endpoint 6 High
0x164	USBRXMAXP6	USB Maximum Receive Data Endpoint 6
0x166	USBRXCURL6	USB Receive Control and Status Endpoint 6 Low
0x167	USBRXCSRH6	USB Receive Control and Status Endpoint 6 High
0x168	USBRXCOUNT6	USB Receive Byte Count Endpoint 6
0x16A	USBTXTYPE6	USB Host Transmit Configure Type Endpoint 6
0x16B	USBTXINTERVAL6	USB Host Transmit Interval Endpoint 6
0x16C	USBRXTYPE6	USB Host Configure Receive Type Endpoint 6
0x16D	USBRXINTERVAL6	USB Host Receive Polling Interval Endpoint 6
0x170	USBTXMAXP7	USB Maximum Transmit Data Endpoint 7
0x172	USBTXCURL7	USB Transmit Control and Status Endpoint 7 Low
0x173	USBTXCSRH7	USB Transmit Control and Status Endpoint 7 High
0x174	USBRXMAXP7	USB Maximum Receive Data Endpoint 7
0x176	USBRXCURL7	USB Receive Control and Status Endpoint 7 Low
0x177	USBRXCSRH7	USB Receive Control and Status Endpoint 7 High
0x178	USBRXCOUNT7	USB Receive Byte Count Endpoint 7
0x17A	USBTXTYPE7	USB Host Transmit Configure Type Endpoint 7
0x17B	USBTXINTERVAL7	USB Host Transmit Interval Endpoint 7
0x17C	USBRXTYPE7	USB Host Configure Receive Type Endpoint 7
0x17D	USBRXINTERVAL7	USB Host Receive Polling Interval Endpoint 7
0x200	USBDMAINTR	USB DMA Interrupt
0x204	USBDMACTL0	USB DMA Control 0
0x208	USBDMAADDR0	USB DMA Address 0

Table 24-2. List of Registers (continued)

Offset	Name	Description
0x20C	USBDMACOUNT0	USB DMA Count 0
0x214	USBDMACTL1	USB DMA Control 1
0x218	USBDMAADDR1	USB DMA Address 1
0x21C	USBDMACOUNT1	USB DMA Count 1
0x224	USBDMACTL2	USB DMA Control 2
0x228	USBDMAADDR2	USB DMA Address 2
0x22C	USBDMACOUNT2	USB DMA Count 2
0x234	USBDMACTL3	USB DMA Control 3
0x238	USBDMAADDR3	USB DMA Address 3
0x23C	USBDMACOUNT3	USB DMA Count 3
0x244	USBDMACTL4	USB DMA Control 4
0x248	USBDMAADDR4	USB DMA Address 4
0x24C	USBDMACOUNT4	USB DMA Count 4
0x254	USBDMACTL5	USB DMA Control 5
0x258	USBDMAADDR5	USB DMA Address 5
0x25C	USBDMACOUNT5	USB DMA Count 5
0x264	USBDMACTL6	USB DMA Control 6
0x268	USBDMAADDR6	USB DMA Address 6
0x26C	USBDMACOUNT6	USB DMA Count 6
0x274	USBDMACTL7	USB DMA Control 7
0x278	USBDMAADDR7	USB DMA Address 7
0x27C	USBDMACOUNT7	USB DMA Count 7
0x304	USBRQPKTCOUNT1	USB Request Packet Count in Block Transfer Endpoint 1
0x308	USBRQPKTCOUNT2	USB Request Packet Count in Block Transfer Endpoint 2
0x30C	USBRQPKTCOUNT3	USB Request Packet Count in Block Transfer Endpoint 3
0x310	USBRQPKTCOUNT4	USB Request Packet Count in Block Transfer Endpoint 4
0x314	USBRQPKTCOUNT5	USB Request Packet Count in Block Transfer Endpoint 5
0x318	USBRQPKTCOUNT6	USB Request Packet Count in Block Transfer Endpoint 6
0x31C	USBRQPKTCOUNT7	USB Request Packet Count in Block Transfer Endpoint 7
0x340	USBRXDPKTBUFDIS	USB Receive Double Packet Buffer Disable
0x342	USBTXDPKTBUFDIS	USB Transmit Double Packet Buffer Disable
0x344	USBCTO	USB Chirp Timeout
0x346	USBHHSRTN	USB High Speed to UTM Operating Delay
0x348	USBHSBT	USB High Speed Time-out Adder
0x360	USBLPMATTR	USB LPM Attributes
0x362	USBLPMCNTL	USB LPM Control
0x363	USBLPMIM	USB LPM Interrupt Mask
0x364	USBLPMRIS	USB LPM Raw Interrupt Status
0x365	USBLPMFADDR	USB LPM Function Address
0x400	USBEPCC	USB External Power Control
0x404	USBEPCCRIS	USB External Power Control Raw Interrupt Status
0x408	USBEPCCIM	USB External Power Control Interrupt Mask

Table 24-2. List of Registers (continued)

Offset	Name	Description
0x40C	USBEPICISC	USB External Power Control Interrupt Status and Clear
0x410	USBDRRIS	USB Device RESUME Raw Interrupt Status
0x414	USBDRIM	USB Device RESUME Interrupt Mask
0x418	USBDRISC	USB Device RESUME Interrupt Status and Clear
0x41C	USBGPCS	USB General-Purpose Control and Status
0x430	USBVDC	USB VBUS Droop Control
0x434	USBVDCRIS	USB VBUS Droop Control Raw Interrupt Status
0x438	USBVDCIM	USB VBUS Droop Control Interrupt Mask
0x43C	USBVDCISC	USB VBUS Droop Control Interrupt Status and Clear
0xFC0	USBPP	USB Peripheral Properties
0xFC4	USBPC	USB Peripheral Configuration
0xFC8	USBCC	USB Clock Configuration

25 Analog Comparators

An analog comparator is a peripheral that compares two analog voltages and provides a logical output that signals the comparison result.

Note: Not all comparators have the option to drive an output pin. See “Signal Description” on page 1778 for more information.

The comparator can provide its output to a device pin, acting as a replacement for an analog comparator on the board. In addition, the comparator can signal the application via interrupts or trigger the start of a sample sequence in the ADC. The interrupt generation and ADC triggering logic is separate and independent. This flexibility means, for example, that an interrupt can be generated on a rising edge and the ADC triggered on a falling edge.

The TM4C129ENC PDT microcontroller provides three independent integrated analog comparators with the following functions:

- Compare external pin input to external pin input or to internal programmable voltage reference
- Compare a test voltage against any one of the following voltages:
 - An individual external reference voltage
 - A shared single external reference voltage
 - A shared internal reference voltage

25.1 Block Diagram

Figure 25-1. Analog Comparator Module Block Diagram

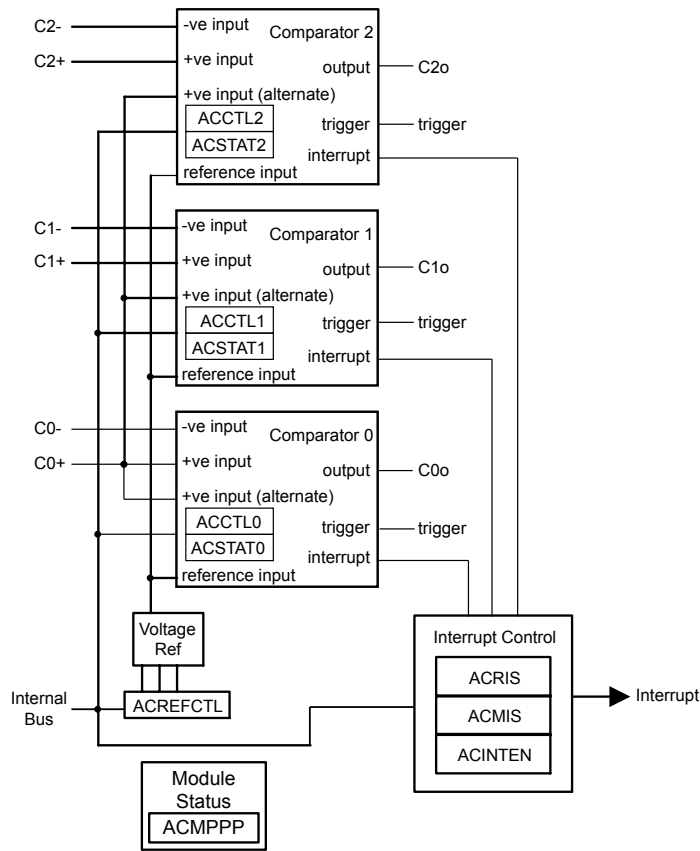

Note: This block diagram depicts the maximum number of analog comparators and comparator outputs for the family of microcontrollers; the number for this specific device may vary. See page 1791 for what is included on this device.

25.2 Signal Description

The following table lists the external signals of the Analog Comparators and describes the function of each. The Analog Comparator output signals are alternate functions for some GPIO signals and default to be GPIO signals at reset. The column in the table below titled "Pin Mux/Pin Assignment" lists the possible GPIO pin placements for the Analog Comparator signals. The `AFSEL` bit in the **GPIO Alternate Function Select (GPIOAFSEL)** register (page 778) should be set to choose the Analog Comparator function. The number in parentheses is the encoding that must be programmed into the `PMCn` field in the **GPIO Port Control (GPIOPCTL)** register (page 795) to assign the Analog Comparator signal to the specified GPIO port pin. The positive and negative input signals are configured by clearing the `DEN` bit in the **GPIO Digital Enable (GPIODEN)** register. For more information on configuring GPIOs, see "General-Purpose Input/Outputs (GPIOs)" on page 750.

Table 25-1. Analog Comparators Signals (128TQFP)

Pin Name	Pin Number	Pin Mux / Pin Assignment	Pin Type	Buffer Type	Description
C0+	23	PC6	I	Analog	Analog comparator 0 positive input.

Table 25-1. Analog Comparators Signals (128TQFP) (continued)

Pin Name	Pin Number	Pin Mux / Pin Assignment	Pin Type	Buffer Type	Description
C0-	22	PC7	I	Analog	Analog comparator 0 negative input.
C0o	1 83	PD0 (5) PL2 (5)	O	TTL	Analog comparator 0 output.
C1+	24	PC5	I	Analog	Analog comparator 1 positive input.
C1-	25	PC4	I	Analog	Analog comparator 1 negative input.
C1o	2 84	PD1 (5) PL3 (5)	O	TTL	Analog comparator 1 output.
C2+	118	PP0	I	Analog	Analog comparator 2 positive input.
C2-	119	PP1	I	Analog	Analog comparator 2 negative input.
C2o	3	PD2 (5)	O	TTL	Analog comparator 2 output.

25.3 Functional Description

The comparator compares the VIN- and VIN+ inputs to produce an output, VOUT.

$$VIN- < VIN+, VOUT = 1$$

$$VIN- > VIN+, VOUT = 0$$

As shown in Figure 25-2 on page 1779, the input source for VIN- is an external input, Cn-, where n is the analog comparator number. In addition to an external input, Cn+, input sources for VIN+ can be the C0+ or an internal reference, V_{IREF}.

Figure 25-2. Structure of Comparator Unit

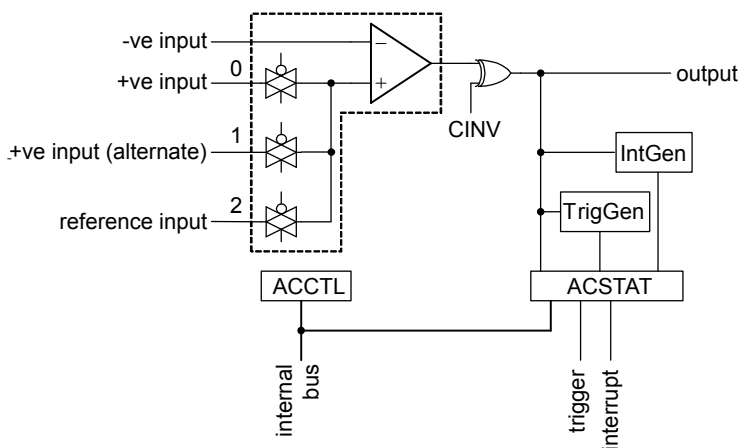

A comparator is configured through two status/control registers, **Analog Comparator Control (ACCTL)** and **Analog Comparator Status (ACSTAT)**. The internal reference is configured through one control register, **Analog Comparator Reference Voltage Control (ACREFCTL)**. Interrupt status and control are configured through three registers, **Analog Comparator Masked Interrupt Status (ACMIS)**, **Analog Comparator Raw Interrupt Status (ACRIS)**, and **Analog Comparator Interrupt Enable (ACINTEN)**.

Typically, the comparator output is used internally to generate an interrupt as controlled by the I_{SEN} bit in the **ACCTL** register. The output may also be used to drive one of the external pins (C_{no}), or generate an analog-to-digital converter (ADC) trigger.

Important: The `ASRCP` bits in the `ACCTL` register must be set before using the analog comparators.

25.3.1 Internal Reference Programming

The structure of the internal reference is shown in Figure 25-3 on page 1780. The internal reference is controlled by a single configuration register (`ACREFCTL`).

Figure 25-3. Comparator Internal Reference Structure

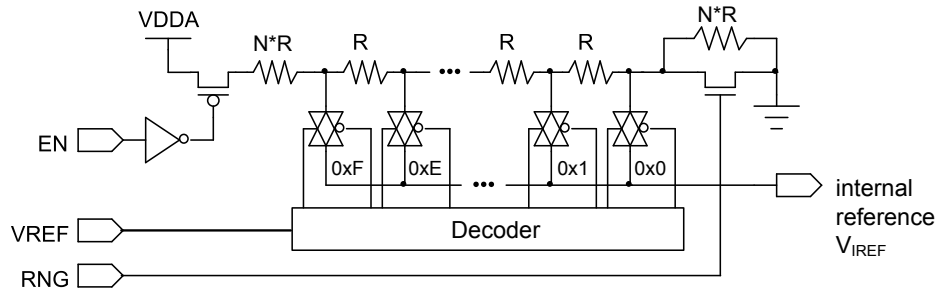

Note: In the figure above, $N \cdot R$ represents a multiple of the R value that produces the results specified in Table 25-2 on page 1780.

The internal reference can be programmed in one of two modes (low range or high range) depending on the `RNG` bit in the `ACREFCTL` register. When `RNG` is clear, the internal reference is in high-range mode, and when `RNG` is set the internal reference is in low-range mode.

In each range, the internal reference, V_{IREF} , has 16 preprogrammed thresholds or step values. The threshold to be used to compare the external input voltage against is selected using the `VREF` field in the `ACREFCTL` register.

In the high-range mode, the V_{IREF} threshold voltages start at the ideal high-range starting voltage of $V_{DDA}/4.2$ and increase in ideal constant voltage steps of $V_{DDA}/29.4$.

In the low-range mode, the V_{IREF} threshold voltages start at 0 V and increase in ideal constant voltage steps of $V_{DDA}/22.12$. The ideal V_{IREF} step voltages for each mode and their dependence on the `RNG` and `VREF` fields are summarized in Table 25-2.

Table 25-2. Internal Reference Voltage and `ACREFCTL` Field Values

ACREFCTL Register		Output Reference Voltage Based on <code>VREF</code> Field Value
<code>EN</code> Bit Value	<code>RNG</code> Bit Value	
<code>EN=0</code>	<code>RNG=X</code>	0 V (GND) for any value of <code>VREF</code> . It is recommended that <code>RNG=1</code> and <code>VREF=0</code> to minimize noise on the reference ground.

Table 25-2. Internal Reference Voltage and ACREFACTL Field Values (continued)

ACREFACTL Register		Output Reference Voltage Based on VREF Field Value
EN Bit Value	RNG Bit Value	
EN=1	RNG=0	<p>V_{IREF} High Range: 16 voltage threshold values indexed by VREF = 0x0 .. 0xF</p> <p>Ideal starting voltage (VREF=0): V_{DDA} / 4.2</p> <p>Ideal step size: V_{DDA} / 29.4</p> <p>Ideal V_{IREF} threshold values: V_{IREF} (VREF) = V_{DDA} / 4.2 + VREF * (V_{DDA} / 29.4), for VREF = 0x0 .. 0xF</p> <p>For minimum and maximum V_{IREF} threshold values, see Table 25-3 on page 1781.</p>
	RNG=1	<p>V_{IREF} Low Range: 16 voltage threshold values indexed by VREF = 0x0 .. 0xF</p> <p>Ideal starting voltage (VREF=0): 0 V</p> <p>Ideal step size: V_{DDA} / 22.12</p> <p>Ideal V_{IREF} threshold values: V_{IREF} (VREF) = VREF * (V_{DDA} / 22.12), for VREF = 0x0 .. 0xF</p> <p>For minimum and maximum V_{IREF} threshold values, see Table 25-4 on page 1782.</p>

Note that the values shown in Table 25-2 are the ideal values of the V_{IREF} thresholds. These values actually vary between minimum and maximum values for each threshold step, depending on process and temperature. The minimum and maximum values for each step are given by:

- V_{IREF}(VREF) [Min] = Ideal V_{IREF}(VREF) – (Ideal Step size – 2 mV) / 2
- V_{IREF}(VREF) [Max] = Ideal V_{IREF}(VREF) + (Ideal Step size – 2 mV) / 2

Examples of minimum and maximum V_{IREF} values for V_{DDA} = 3.3V for high and low ranges, are shown in Table 25-3 and Table 25-4. Note that these examples are only valid for V_{DDA} = 3.3V; values scale up and down with V_{DDA}.

Table 25-3. Analog Comparator Voltage Reference Characteristics, V_{DDA} = 3.3V, EN= 1, and RNG = 0

VREF Value	V _{IREF} Min	Ideal V _{IREF}	V _{IREF} Max	Unit
0x0	0.731	0.786	0.841	V
0x1	0.843	0.898	0.953	V
0x2	0.955	1.010	1.065	V
0x3	1.067	1.122	1.178	V
0x4	1.180	1.235	1.290	V
0x5	1.292	1.347	1.402	V
0x6	1.404	1.459	1.514	V
0x7	1.516	1.571	1.627	V
0x8	1.629	1.684	1.739	V
0x9	1.741	1.796	1.851	V
0xA	1.853	1.908	1.963	V
0xB	1.965	2.020	2.076	V
0xC	2.078	2.133	2.188	V
0xD	2.190	2.245	2.300	V
0xE	2.302	2.357	2.412	V
0xF	2.414	2.469	2.525	V

Table 25-4. Analog Comparator Voltage Reference Characteristics, $V_{DDA} = 3.3V$, $EN = 1$, and $RNG = 1$

V _{REF} Value	V _{IREF} Min	Ideal V _{IREF}	V _{IREF} Max	Unit
0x0	0.000	0.000	0.074	V
0x1	0.076	0.149	0.223	V
0x2	0.225	0.298	0.372	V
0x3	0.374	0.448	0.521	V
0x4	0.523	0.597	0.670	V
0x5	0.672	0.746	0.820	V
0x6	0.822	0.895	0.969	V
0x7	0.971	1.044	1.118	V
0x8	1.120	1.193	1.267	V
0x9	1.269	1.343	1.416	V
0xA	1.418	1.492	1.565	V
0xB	1.567	1.641	1.715	V
0xC	1.717	1.790	1.864	V
0xD	1.866	1.939	2.013	V
0xE	2.015	2.089	2.162	V
0xF	2.164	2.238	2.311	V

25.4 Initialization and Configuration

The following example shows how to configure an analog comparator to read back its output value from an internal register.

1. Enable the analog comparator clock by writing a value of 0x0000.0001 to the **RCGCACMP** register in the System Control module (see page 404).
2. Enable the clock to the appropriate GPIO modules via the **RCGCGPIO** register (see page 389). To find out which GPIO ports to enable, refer to Table 29-5 on page 1932.
3. In the GPIO module, enable the GPIO port/pin associated with the input signals as GPIO inputs. To determine which GPIO to configure, see Table 29-4 on page 1921.
4. Configure the **PMC_n** fields in the **GPIOPCTL** register to assign the analog comparator output signals to the appropriate pins (see page 795 and Table 29-5 on page 1932).
5. Configure the internal voltage reference to 1.65 V by writing the **ACREFCTL** register with the value 0x0000.030C.
6. Configure the comparator to use the internal voltage reference and to *not* invert the output by writing the **ACCTL_n** register with the value of 0x0000.040C.
7. Delay for 10 μ s.
8. Read the comparator output value by reading the **ACSTAT_n** register's **OV_{AL}** value.

Change the level of the comparator negative input signal **C-** to see the **OV_{AL}** value change.

25.5 Register Map

Table 25-5 on page 1783 lists the comparator registers. The offset listed is a hexadecimal increment to the register's address, relative to the Analog Comparator base address of 0x4003.C000. Note that the analog comparator clock must be enabled before the registers can be programmed (see page 404). There must be a delay of 3 system clocks after the analog comparator module clock is enabled before any analog comparator module registers are accessed.

Table 25-5. Analog Comparators Register Map

Offset	Name	Type	Reset	Description	See page
0x000	ACMIS	RW1C	0x0000.0000	Analog Comparator Masked Interrupt Status	1784
0x004	ACRIS	RO	0x0000.0000	Analog Comparator Raw Interrupt Status	1785
0x008	ACINTEN	RW	0x0000.0000	Analog Comparator Interrupt Enable	1786
0x010	ACREFCTL	RW	0x0000.0000	Analog Comparator Reference Voltage Control	1787
0x020	ACSTAT0	RO	0x0000.0000	Analog Comparator Status 0	1788
0x024	ACCTL0	RW	0x0000.0000	Analog Comparator Control 0	1789
0x040	ACSTAT1	RO	0x0000.0000	Analog Comparator Status 1	1788
0x044	ACCTL1	RW	0x0000.0000	Analog Comparator Control 1	1789
0x060	ACSTAT2	RO	0x0000.0000	Analog Comparator Status 2	1788
0x064	ACCTL2	RW	0x0000.0000	Analog Comparator Control 2	1789
0xFC0	ACMPPP	RO	0x0007.0007	Analog Comparator Peripheral Properties	1791

25.6 Register Descriptions

The remainder of this section lists and describes the Analog Comparator registers, in numerical order by address offset.

Register 1: Analog Comparator Masked Interrupt Status (ACMIS), offset 0x000

This register provides a summary of the interrupt status (masked) of the comparators.

Analog Comparator Masked Interrupt Status (ACMIS)

Base 0x4003.C000
 Offset 0x000
 Type RW1C, reset 0x0000.0000

	31	30	29	28	27	26	25	24	23	22	21	20	19	18	17	16
	reserved															
Type	RO	RO	RO	RO	RO	RO	RO	RO	RO	RO	RO	RO	RO	RO	RO	RO
Reset	0	0	0	0	0	0	0	0	0	0	0	0	0	0	0	0
	15	14	13	12	11	10	9	8	7	6	5	4	3	2	1	0
	reserved													IN2	IN1	IN0
Type	RO	RO	RO	RO	RO	RO	RO	RO	RO	RO	RO	RO	RO	RW1C	RW1C	RW1C
Reset	0	0	0	0	0	0	0	0	0	0	0	0	0	0	0	0

Bit/Field	Name	Type	Reset	Description
31:3	reserved	RO	0x0000.000	Software should not rely on the value of a reserved bit. To provide compatibility with future products, the value of a reserved bit should be preserved across a read-modify-write operation.
2	IN2	RW1C	0	<p>Comparator 2 Masked Interrupt Status</p> <p>Value Description</p> <p>0 No interrupt has occurred or the interrupt is masked.</p> <p>1 The IN2 bits in the ACRIS register and the ACINTEN registers are set, providing an interrupt to the interrupt controller.</p> <p>This bit is cleared by writing a 1. Clearing this bit also clears the IN2 bit in the ACRIS register.</p>
1	IN1	RW1C	0	<p>Comparator 1 Masked Interrupt Status</p> <p>Value Description</p> <p>0 No interrupt has occurred or the interrupt is masked.</p> <p>1 The IN1 bits in the ACRIS register and the ACINTEN registers are set, providing an interrupt to the interrupt controller.</p> <p>This bit is cleared by writing a 1. Clearing this bit also clears the IN1 bit in the ACRIS register.</p>
0	IN0	RW1C	0	<p>Comparator 0 Masked Interrupt Status</p> <p>Value Description</p> <p>0 No interrupt has occurred or the interrupt is masked.</p> <p>1 The IN0 bits in the ACRIS register and the ACINTEN registers are set, providing an interrupt to the interrupt controller.</p> <p>This bit is cleared by writing a 1. Clearing this bit also clears the IN0 bit in the ACRIS register.</p>

Register 2: Analog Comparator Raw Interrupt Status (ACRIS), offset 0x004

This register provides a summary of the interrupt status (raw) of the comparators. The bits in this register must be enabled to generate interrupts using the **ACINTEN** register.

Analog Comparator Raw Interrupt Status (ACRIS)

Base 0x4003.C000

Offset 0x004

Type RO, reset 0x0000.0000

	31	30	29	28	27	26	25	24	23	22	21	20	19	18	17	16
	reserved															
Type	RO	RO	RO	RO	RO	RO	RO	RO	RO	RO	RO	RO	RO	RO	RO	RO
Reset	0	0	0	0	0	0	0	0	0	0	0	0	0	0	0	0
	15	14	13	12	11	10	9	8	7	6	5	4	3	2	1	0
	reserved													IN2	IN1	IN0
Type	RO	RO	RO	RO	RO	RO	RO	RO	RO	RO	RO	RO	RO	RO	RO	RO
Reset	0	0	0	0	0	0	0	0	0	0	0	0	0	0	0	0

Bit/Field	Name	Type	Reset	Description
31:3	reserved	RO	0x0000.000	Software should not rely on the value of a reserved bit. To provide compatibility with future products, the value of a reserved bit should be preserved across a read-modify-write operation.
2	IN2	RO	0	<p>Comparator 2 Interrupt Status</p> <p>Value Description</p> <p>0 An interrupt has not occurred.</p> <p>1 Comparator 2 has generated an interrupt for an event as configured by the ISEN bit in the ACCTL2 register.</p> <p>This bit is cleared by writing a 1 to the IN2 bit in the ACMIS register.</p>
1	IN1	RO	0	<p>Comparator 1 Interrupt Status</p> <p>Value Description</p> <p>0 An interrupt has not occurred.</p> <p>1 Comparator 1 has generated an interrupt for an event as configured by the ISEN bit in the ACCTL1 register.</p> <p>This bit is cleared by writing a 1 to the IN1 bit in the ACMIS register.</p>
0	IN0	RO	0	<p>Comparator 0 Interrupt Status</p> <p>Value Description</p> <p>0 An interrupt has not occurred.</p> <p>1 Comparator 0 has generated an interrupt for an event as configured by the ISEN bit in the ACCTL0 register.</p> <p>This bit is cleared by writing a 1 to the IN0 bit in the ACMIS register.</p>

Register 3: Analog Comparator Interrupt Enable (ACINTEN), offset 0x008

This register provides the interrupt enable for the comparators.

Analog Comparator Interrupt Enable (ACINTEN)

Base 0x4003.C000
 Offset 0x008
 Type RW, reset 0x0000.0000

	31	30	29	28	27	26	25	24	23	22	21	20	19	18	17	16	
	reserved																
Type	RO	RO	RO	RO	RO	RO	RO	RO	RO	RO	RO	RO	RO	RO	RO	RO	
Reset	0	0	0	0	0	0	0	0	0	0	0	0	0	0	0	0	
	15	14	13	12	11	10	9	8	7	6	5	4	3	2	1	0	
	reserved													IN2	IN1	IN0	
Type	RO	RO	RO	RO	RO	RO	RO	RO	RO	RO	RO	RO	RO	RO	RW	RW	RW
Reset	0	0	0	0	0	0	0	0	0	0	0	0	0	0	0	0	0

Bit/Field	Name	Type	Reset	Description
31:3	reserved	RO	0x00	Software should not rely on the value of a reserved bit. To provide compatibility with future products, the value of a reserved bit should be preserved across a read-modify-write operation.
2	IN2	RW	0	Comparator 2 Interrupt Enable Value Description 0 A comparator 2 interrupt does not affect the interrupt status. 1 The raw interrupt signal comparator 2 is sent to the interrupt controller.
1	IN1	RW	0	Comparator 1 Interrupt Enable Value Description 0 A comparator 1 interrupt does not affect the interrupt status. 1 The raw interrupt signal comparator 1 is sent to the interrupt controller.
0	IN0	RW	0	Comparator 0 Interrupt Enable Value Description 0 A comparator 0 interrupt does not affect the interrupt status. 1 The raw interrupt signal comparator 0 is sent to the interrupt controller.

Register 4: Analog Comparator Reference Voltage Control (ACREFCTL), offset 0x010

This register specifies whether the resistor ladder is powered on as well as the range and tap.

Analog Comparator Reference Voltage Control (ACREFCTL)

Base 0x4003.C000

Offset 0x010

Type RW, reset 0x0000.0000

	31	30	29	28	27	26	25	24	23	22	21	20	19	18	17	16	
	reserved																
Type	RO	RO	RO	RO	RO	RO	RO	RO	RO	RO	RO	RO	RO	RO	RO	RO	
Reset	0	0	0	0	0	0	0	0	0	0	0	0	0	0	0	0	
	15	14	13	12	11	10	9	8	7	6	5	4	3	2	1	0	
	reserved						EN	RNG	reserved					VREF			
Type	RO	RO	RO	RO	RO	RO	RW	RW	RO	RO	RO	RO	RW	RW	RW	RW	
Reset	0	0	0	0	0	0	0	0	0	0	0	0	0	0	0	0	

Bit/Field	Name	Type	Reset	Description
31:10	reserved	RO	0x0000.0	Software should not rely on the value of a reserved bit. To provide compatibility with future products, the value of a reserved bit should be preserved across a read-modify-write operation.
9	EN	RW	0	Resistor Ladder Enable Value Description 0 The resistor ladder is unpowered. 1 Powers on the resistor ladder. The resistor ladder is connected to V_{DDA} . This bit is cleared at reset so that the internal reference consumes the least amount of power if it is not used.
8	RNG	RW	0	Resistor Ladder Range Value Description 0 The ideal step size for the internal reference is $V_{DDA} / 29.4$. 1 The ideal step size for the internal reference is $V_{DDA} / 22.12$.
7:4	reserved	RO	0x0	Software should not rely on the value of a reserved bit. To provide compatibility with future products, the value of a reserved bit should be preserved across a read-modify-write operation.
3:0	VREF	RW	0x0	Resistor Ladder Voltage Ref The V_{REF} bit field specifies the resistor ladder tap that is passed through an analog multiplexer. The voltage corresponding to the tap position is the internal reference voltage available for comparison. See Table 25-2 on page 1780 for some output reference voltage examples.

Register 5: Analog Comparator Status 0 (ACSTAT0), offset 0x020

Register 6: Analog Comparator Status 1 (ACSTAT1), offset 0x040

Register 7: Analog Comparator Status 2 (ACSTAT2), offset 0x060

These registers specify the current output value of the comparator.

Analog Comparator Status n (ACSTATn)

Base 0x4003.C000
 Offset 0x020
 Type RO, reset 0x0000.0000

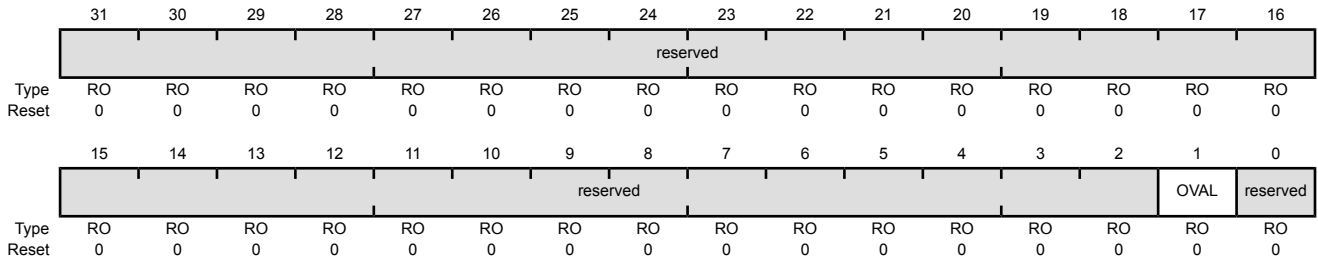

Bit/Field	Name	Type	Reset	Description
31:2	reserved	RO	0x0000.000	Software should not rely on the value of a reserved bit. To provide compatibility with future products, the value of a reserved bit should be preserved across a read-modify-write operation.
1	OVAL	RO	0	Comparator Output Value Value Description 0 VIN- > VIN+ 1 VIN- < VIN+ VIN- is the voltage on the C _{n-} pin. VIN+ is the voltage on the C _{n+} pin, the C0+ pin, or the internal voltage reference (V _{REF}) as defined by the ASRCP bit in the ACCTL register.
0	reserved	RO	0	Software should not rely on the value of a reserved bit. To provide compatibility with future products, the value of a reserved bit should be preserved across a read-modify-write operation.

Register 8: Analog Comparator Control 0 (ACCTL0), offset 0x024**Register 9: Analog Comparator Control 1 (ACCTL1), offset 0x044****Register 10: Analog Comparator Control 2 (ACCTL2), offset 0x064**

These registers configure the comparator's input and output.

Analog Comparator Control n (ACCTLn)

Base 0x4003.C000

Offset 0x024

Type RW, reset 0x0000.0000

	31	30	29	28	27	26	25	24	23	22	21	20	19	18	17	16
	reserved															
Type	RO	RO	RO	RO	RO	RO	RO	RO	RO	RO	RO	RO	RO	RO	RO	RO
Reset	0	0	0	0	0	0	0	0	0	0	0	0	0	0	0	0
	15	14	13	12	11	10	9	8	7	6	5	4	3	2	1	0
	reserved				TOEN	ASRCP		reserved	TSLVAL	TSEN		ISLVAL	ISEN		CINV	reserved
Type	RO	RO	RO	RO	RW	RW	RW	RO	RW	RW	RW	RW	RW	RW	RW	RO
Reset	0	0	0	0	0	0	0	0	0	0	0	0	0	0	0	0

Bit/Field	Name	Type	Reset	Description
31:12	reserved	RO	0x0000.0	Software should not rely on the value of a reserved bit. To provide compatibility with future products, the value of a reserved bit should be preserved across a read-modify-write operation.
11	TOEN	RW	0	Trigger Output Enable Value Description 0 ADC events are suppressed and not sent to the ADC. 1 ADC events are sent to the ADC.
10:9	ASRCP	RW	0x0	Analog Source Positive The ASRCP field specifies the source of input voltage to the VIN+ terminal of the comparator. The encodings for this field are as follows: Value Description 0x0 Pin value of Cn+ 0x1 Pin value of C0+ 0x2 Internal voltage reference (V _{REF}) 0x3 Reserved
8	reserved	RO	0	Software should not rely on the value of a reserved bit. To provide compatibility with future products, the value of a reserved bit should be preserved across a read-modify-write operation.
7	TSLVAL	RW	0	Trigger Sense Level Value Value Description 0 An ADC event is generated if the comparator output is Low. 1 An ADC event is generated if the comparator output is High.

Bit/Field	Name	Type	Reset	Description										
6:5	TSEN	RW	0x0	<p>Trigger Sense</p> <p>The TSEN field specifies the sense of the comparator output that generates an ADC event. The sense conditioning is as follows:</p> <table border="1"> <thead> <tr> <th>Value</th> <th>Description</th> </tr> </thead> <tbody> <tr> <td>0x0</td> <td>Level sense, see TSLVAL</td> </tr> <tr> <td>0x1</td> <td>Falling edge</td> </tr> <tr> <td>0x2</td> <td>Rising edge</td> </tr> <tr> <td>0x3</td> <td>Either edge</td> </tr> </tbody> </table>	Value	Description	0x0	Level sense, see TSLVAL	0x1	Falling edge	0x2	Rising edge	0x3	Either edge
Value	Description													
0x0	Level sense, see TSLVAL													
0x1	Falling edge													
0x2	Rising edge													
0x3	Either edge													
4	ISLVAL	RW	0	<p>Interrupt Sense Level Value</p> <table border="1"> <thead> <tr> <th>Value</th> <th>Description</th> </tr> </thead> <tbody> <tr> <td>0</td> <td>An interrupt is generated if the comparator output is Low.</td> </tr> <tr> <td>1</td> <td>An interrupt is generated if the comparator output is High.</td> </tr> </tbody> </table>	Value	Description	0	An interrupt is generated if the comparator output is Low.	1	An interrupt is generated if the comparator output is High.				
Value	Description													
0	An interrupt is generated if the comparator output is Low.													
1	An interrupt is generated if the comparator output is High.													
3:2	ISEN	RW	0x0	<p>Interrupt Sense</p> <p>The ISEN field specifies the sense of the comparator output that generates an interrupt. The sense conditioning is as follows:</p> <table border="1"> <thead> <tr> <th>Value</th> <th>Description</th> </tr> </thead> <tbody> <tr> <td>0x0</td> <td>Level sense, see ISLVAL</td> </tr> <tr> <td>0x1</td> <td>Falling edge</td> </tr> <tr> <td>0x2</td> <td>Rising edge</td> </tr> <tr> <td>0x3</td> <td>Either edge</td> </tr> </tbody> </table>	Value	Description	0x0	Level sense, see ISLVAL	0x1	Falling edge	0x2	Rising edge	0x3	Either edge
Value	Description													
0x0	Level sense, see ISLVAL													
0x1	Falling edge													
0x2	Rising edge													
0x3	Either edge													
1	CINV	RW	0	<p>Comparator Output Invert</p> <table border="1"> <thead> <tr> <th>Value</th> <th>Description</th> </tr> </thead> <tbody> <tr> <td>0</td> <td>The output of the comparator is unchanged.</td> </tr> <tr> <td>1</td> <td>The output of the comparator is inverted prior to being processed by hardware.</td> </tr> </tbody> </table>	Value	Description	0	The output of the comparator is unchanged.	1	The output of the comparator is inverted prior to being processed by hardware.				
Value	Description													
0	The output of the comparator is unchanged.													
1	The output of the comparator is inverted prior to being processed by hardware.													
0	reserved	RO	0	Software should not rely on the value of a reserved bit. To provide compatibility with future products, the value of a reserved bit should be preserved across a read-modify-write operation.										

Register 11: Analog Comparator Peripheral Properties (ACMPPP), offset 0xFC0

The **ACMPPP** register provides information regarding the properties of the analog comparator module.

Analog Comparator Peripheral Properties (ACMPPP)

Base 0x4003.C000

Offset 0xFC0

Type RO, reset 0x0007.0007

	31	30	29	28	27	26	25	24	23	22	21	20	19	18	17	16
	reserved													C2O	C1O	C0O
Type	RO	RO	RO	RO	RO	RO	RO	RO	RO	RO	RO	RO	RO	RO	RO	RO
Reset	0	0	0	0	0	0	0	0	0	0	0	0	0	1	1	1
	15	14	13	12	11	10	9	8	7	6	5	4	3	2	1	0
	reserved													CMP2	CMP1	CMP0
Type	RO	RO	RO	RO	RO	RO	RO	RO	RO	RO	RO	RO	RO	RO	RO	RO
Reset	0	0	0	0	0	0	0	0	0	0	0	0	0	1	1	1

Bit/Field	Name	Type	Reset	Description
31:19	reserved	RO	0x0	Software should not rely on the value of a reserved bit. To provide compatibility with future products, the value of a reserved bit should be preserved across a read-modify-write operation.
18	C2O	RO	0x1	Comparator Output 2 Present Value Description 0 Comparator output 2 is not present. 1 Comparator output 2 is present.
17	C1O	RO	0x1	Comparator Output 1 Present Value Description 0 Comparator output 1 is not present. 1 Comparator output 1 is present.
16	C0O	RO	0x1	Comparator Output 0 Present Value Description 0 Comparator output 0 is not present. 1 Comparator output 0 is present.
15:3	reserved	RO	0x0	Software should not rely on the value of a reserved bit. To provide compatibility with future products, the value of a reserved bit should be preserved across a read-modify-write operation.
2	CMP2	RO	0x1	Comparator 2 Present Value Description 0 Comparator 2 is not present. 1 Comparator 2 is present.

Bit/Field	Name	Type	Reset	Description
1	CMP1	RO	0x1	Comparator 1 Present Value Description 0 Comparator 1 is not present. 1 Comparator 1 is present.
0	CMP0	RO	0x1	Comparator 0 Present Value Description 0 Comparator 0 is not present. 1 Comparator 0 is present.

26 Pulse Width Modulator (PWM)

Pulse width modulation (PWM) is a powerful technique for digitally encoding analog signal levels. High-resolution counters are used to generate a square wave, and the duty cycle of the square wave is modulated to encode an analog signal. Typical applications include switching power supplies and motor control.

The TM4C129ENCPDT microcontroller contains one PWM module, with four PWM generator blocks and a control block, for a total of 8 PWM outputs. The control block determines the polarity of the PWM signals, and which signals are passed through to the pins.

Each PWM generator block produces two PWM signals that share the same timer and frequency and can either be programmed with independent actions or as a single pair of complementary signals with dead-band delays inserted. The output signals, `pwmA'` and `pwmB'`, of the PWM generation blocks are managed by the output control block before being passed to the device pins as `MnPWM0` and `MnPWM1` or `MnPWM2` and `MnPWM3`, and so on.

The TM4C129ENCPDT PWM module provides a great deal of flexibility and can generate simple PWM signals, such as those required by a simple charge pump as well as paired PWM signals with dead-band delays, such as those required by a half-H bridge driver. Three generator blocks can also generate the full six channels of gate controls required by a 3-phase inverter bridge.

Each PWM generator block has the following features:

- Four fault-condition handling inputs to quickly provide low-latency shutdown and prevent damage to the motor being controlled
- One 16-bit counter
 - Runs in Down or Up/Down mode
 - Output frequency controlled by a 16-bit load value
 - Load value updates can be synchronized
 - Produces output signals at zero and load value
- Two PWM comparators
 - Comparator value updates can be synchronized
 - Produces output signals on match
- PWM signal generator
 - Output PWM signal is constructed based on actions taken as a result of the counter and PWM comparator output signals
 - Produces two independent PWM signals
- Dead-band generator
 - Produces two PWM signals with programmable dead-band delays suitable for driving a half-H bridge
 - Can be bypassed, leaving input PWM signals unmodified

- Can initiate an ADC sample sequence

The control block determines the polarity of the PWM signals and which signals are passed through to the pins. The output of the PWM generation blocks are managed by the output control block before being passed to the device pins. The PWM control block has the following options:

- PWM output enable of each PWM signal
- Optional output inversion of each PWM signal (polarity control)
- Optional fault handling for each PWM signal
- Synchronization of timers in the PWM generator blocks
- Synchronization of timer/comparator updates across the PWM generator blocks
- Extended PWM synchronization of timer/comparator updates across the PWM generator blocks
- Interrupt status summary of the PWM generator blocks
- Extended PWM fault handling, with multiple fault signals, programmable polarities, and filtering
- PWM generators can be operated independently or synchronized with other generators

26.1 Block Diagram

Figure 26-1 on page 1795 provides the TM4C129ENCPDT PWM module diagram and Figure 26-2 on page 1795 provides a more detailed diagram of a TM4C129ENCPDT PWM generator. The TM4C129ENCPDT controller contains four generator blocks that generate eight independent PWM signals or four paired PWM signals with dead-band delays inserted.

Figure 26-1. PWM Module Diagram

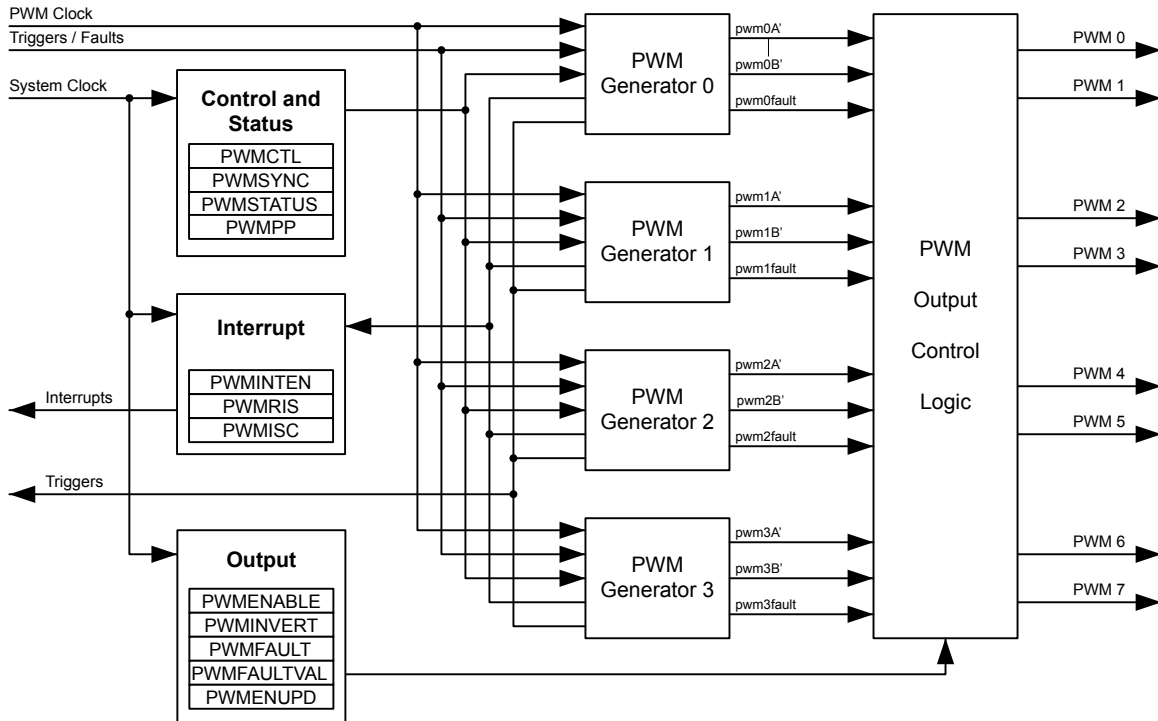
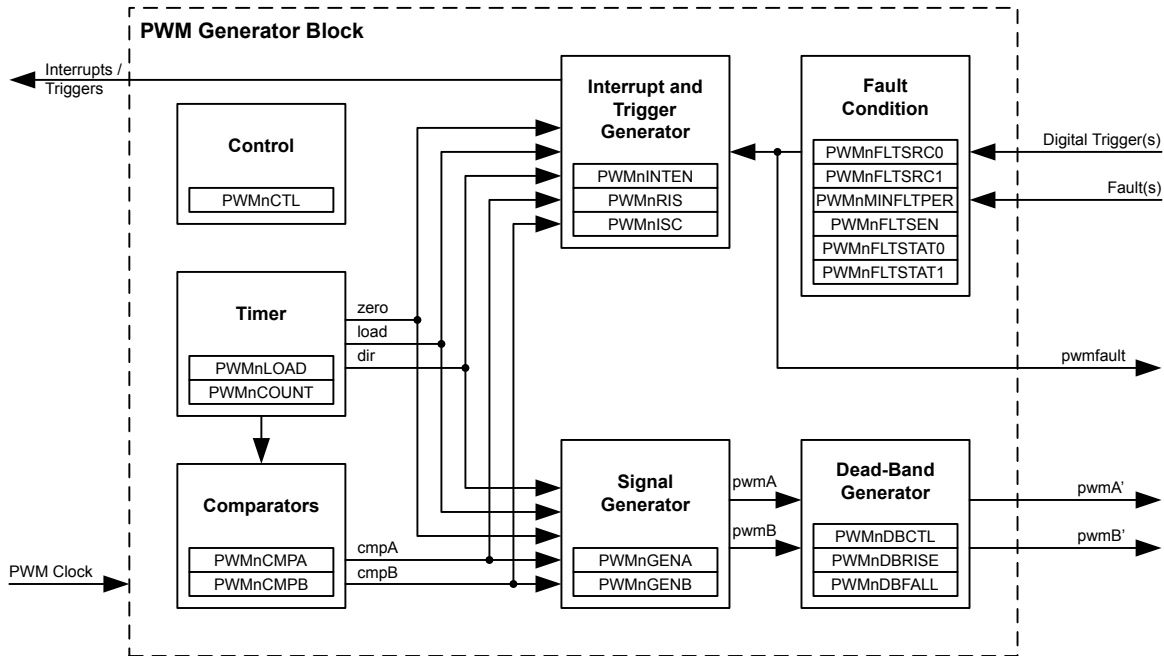

Figure 26-2. PWM Generator Block Diagram



26.2 Signal Description

The following table lists the external signals of the PWM module and describes the function of each. The PWM controller signals are alternate functions for some GPIO signals and default to be GPIO signals at reset. The column in the table below titled "Pin Mux/Pin Assignment" lists the possible GPIO pin placements for these PWM signals. The `AFSEL` bit in the **GPIO Alternate Function Select (GPIOAFSEL)** register (page 778) should be set to choose the PWM function. The number in parentheses is the encoding that must be programmed into the `PMCn` field in the **GPIO Port Control (GPIOPTL)** register (page 795) to assign the PWM signal to the specified GPIO port pin. For more information on configuring GPIOs, see "General-Purpose Input/Outputs (GPIOs)" on page 750.

Table 26-1. PWM Signals (128TQFP)

Pin Name	Pin Number	Pin Mux / Pin Assignment	Pin Type	Buffer Type	Description
M0FAULT0	46	PF4 (6)	I	TTL	Motion Control Module 0 PWM Fault 0.
M0FAULT1	61	PK6 (6)	I	TTL	Motion Control Module 0 PWM Fault 1.
M0FAULT2	60	PK7 (6)	I	TTL	Motion Control Module 0 PWM Fault 2.
M0FAULT3	81	PL0 (6)	I	TTL	Motion Control Module 0 PWM Fault 3.
M0PWM0	42	PF0 (6)	O	TTL	Motion Control Module 0 PWM 0. This signal is controlled by Module 0 PWM Generator 0.
M0PWM1	43	PF1 (6)	O	TTL	Motion Control Module 0 PWM 1. This signal is controlled by Module 0 PWM Generator 0.
M0PWM2	44	PF2 (6)	O	TTL	Motion Control Module 0 PWM 2. This signal is controlled by Module 0 PWM Generator 1.
M0PWM3	45	PF3 (6)	O	TTL	Motion Control Module 0 PWM 3. This signal is controlled by Module 0 PWM Generator 1.
M0PWM4	49	PG0 (6)	O	TTL	Motion Control Module 0 PWM 4. This signal is controlled by Module 0 PWM Generator 2.
M0PWM5	50	PG1 (6)	O	TTL	Motion Control Module 0 PWM 5. This signal is controlled by Module 0 PWM Generator 2.
M0PWM6	63	PK4 (6)	O	TTL	Motion Control Module 0 PWM 6. This signal is controlled by Module 0 PWM Generator 3.
M0PWM7	62	PK5 (6)	O	TTL	Motion Control Module 0 PWM 7. This signal is controlled by Module 0 PWM Generator 3.

26.3 Functional Description

26.3.1 Clock Configuration

The PWM has two clock source options:

- The System Clock
- A predivided System Clock

The clock source is selected by programming the `USEPWM` bit in the **PWM Clock Configuration (PWMCC)** register. The `PWMDIV` bitfield specifies the divisor of the System Clock that is used to create the PWM Clock.

26.3.2 PWM Timer

The timer in each PWM generator runs in one of two modes: Count-Down mode or Count-Up/Down mode. In Count-Down mode, the timer counts from the load value to zero, goes back to the load

value, and continues counting down. In Count-Up/Down mode, the timer counts from zero up to the load value, back down to zero, back up to the load value, and so on. Generally, Count-Down mode is used for generating left- or right-aligned PWM signals, while the Count-Up/Down mode is used for generating center-aligned PWM signals.

The timers output three signals that are used in the PWM generation process: the direction signal (this is always Low in Count-Down mode, but alternates between Low and High in Count-Up/Down mode), a single-clock-cycle-width High pulse when the counter is zero, and a single-clock-cycle-width High pulse when the counter is equal to the load value. Note that in Count-Down mode, the zero pulse is immediately followed by the load pulse. In the figures in this chapter, these signals are labelled "dir," "zero," and "load."

26.3.3 PWM Comparators

Each PWM generator has two comparators that monitor the value of the counter; when either comparator matches the counter, they output a single-clock-cycle-width High pulse, labeled "cmpA" and "cmpB" in the figures in this chapter. When in Count-Up/Down mode, these comparators match both when counting up and when counting down, and thus are qualified by the counter direction signal. These qualified pulses are used in the PWM generation process. If either comparator match value is greater than the counter load value, then that comparator never outputs a High pulse.

Figure 26-3 on page 1798 shows the behavior of the counter and the relationship of these pulses when the counter is in Count-Down mode. Figure 26-4 on page 1798 shows the behavior of the counter and the relationship of these pulses when the counter is in Count-Up/Down mode. In these figures, the following definitions apply:

- LOAD is the value in the **PWMnLOAD** register
- COMPA is the value in the **PWMnCMPA** register
- COMPB is the value in the **PWMnCMPB** register
- 0 is the value zero
- load is the internal signal that has a single-clock-cycle-width High pulse when the counter is equal to the load value
- zero is the internal signal that has a single-clock-cycle-width High pulse when the counter is zero
- cmpA is the internal signal that has a single-clock-cycle-width High pulse when the counter is equal to COMPA
- cmpB is the internal signal that has a single-clock-cycle-width High pulse when the counter is equal to COMPB
- dir is the internal signal that indicates the count direction

Figure 26-3. PWM Count-Down Mode

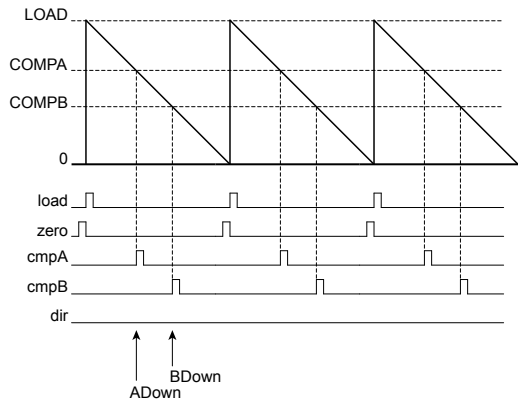
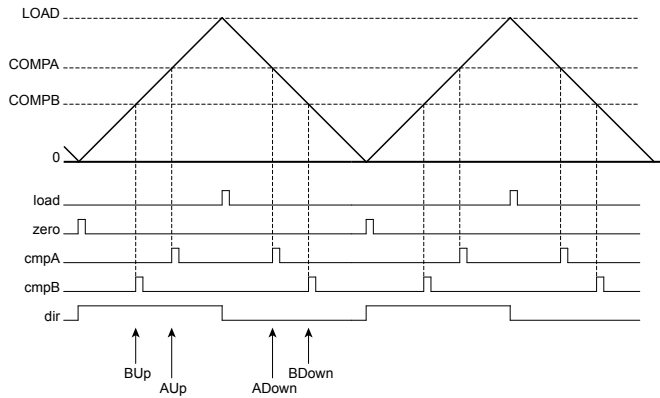

Figure 26-4. PWM Count-Up/Down Mode



26.3.4 PWM Signal Generator

Each PWM generator takes the load, zero, cmpA, and cmpB pulses (qualified by the dir signal) and generates two internal PWM signals, pwmA and pwmB. In Count-Down mode, there are four events that can affect these signals: zero, load, match A down, and match B down. In Count-Up/Down mode, there are six events that can affect these signals: zero, load, match A down, match A up, match B down, and match B up. The match A or match B events are ignored when they coincide with the zero or load events. If the match A and match B events coincide, the first signal, pwmA, is generated based only on the match A event, and the second signal, pwmB, is generated based only on the match B event.

For each event, the effect on each output PWM signal is programmable: it can be left alone (ignoring the event), it can be toggled, it can be driven Low, or it can be driven High. These actions can be used to generate a pair of PWM signals of various positions and duty cycles, which do or do not overlap. Figure 26-5 on page 1799 shows the use of Count-Up/Down mode to generate a pair of center-aligned, overlapped PWM signals that have different duty cycles. This figure shows the pwmA and pwmB signals before they have passed through the dead-band generator.

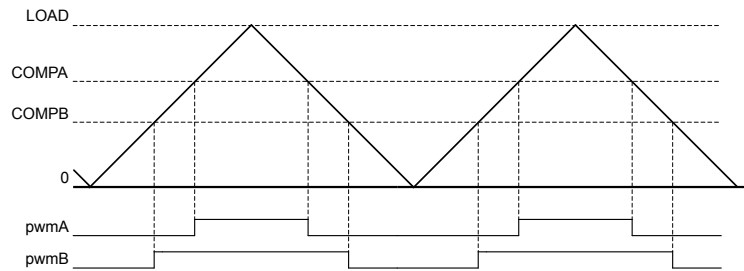
Figure 26-5. PWM Generation Example In Count-Up/Down Mode

In this example, the first generator is set to drive High on match A up, drive Low on match A down, and ignore the other four events. The second generator is set to drive High on match B up, drive Low on match B down, and ignore the other four events. Changing the value of comparator A changes the duty cycle of the pwmA signal, and changing the value of comparator B changes the duty cycle of the pwmB signal.

26.3.5 Dead-Band Generator

The pwmA and pwmB signals produced by each PWM generator are passed to the dead-band generator. If the dead-band generator is disabled, the PWM signals simply pass through to the pwmA' and pwmB' signals unmodified. If the dead-band generator is enabled, the pwmB signal is lost and two PWM signals are generated based on the pwmA signal. The first output PWM signal, pwmA' is the pwmA signal with the rising edge delayed by a programmable amount. The second output PWM signal, pwmB', is the inversion of the pwmA signal with a programmable delay added between the falling edge of the pwmA signal and the rising edge of the pwmB' signal.

The resulting signals are a pair of active High signals where one is always High, except for a programmable amount of time at transitions where both are Low. These signals are therefore suitable for driving a half-H bridge, with the dead-band delays preventing shoot-through current from damaging the power electronics. Figure 26-6 on page 1799 shows the effect of the dead-band generator on the pwmA signal and the resulting pwmA' and pwmB' signals that are transmitted to the output control block.

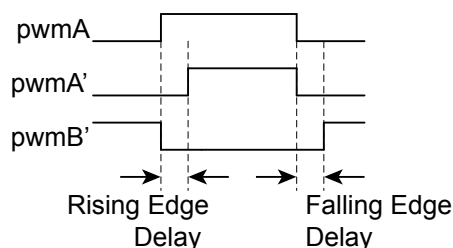
Figure 26-6. PWM Dead-Band Generator

26.3.6 Interrupt/ADC-Trigger Selector

Each PWM generator also takes the same four (or six) counter events and uses them to generate an interrupt or an ADC trigger. Any of these events or a set of these events can be selected as a source for an interrupt; when any of the selected events occur, an interrupt is generated. Additionally, the same event, a different event, the same set of events, or a different set of events can be selected as a source for an ADC trigger; when any of these selected events occur, an ADC trigger pulse is generated. The selection of events allows the interrupt or ADC trigger to occur at a specific position

within the pwmA or pwmB signal. Note that interrupts and ADC triggers are based on the raw events; delays in the PWM signal edges caused by the dead-band generator are not taken into account.

26.3.7 Synchronization Methods

The PWM module provides four PWM generators, each providing two PWM outputs that may be used in a wide variety of applications. Generally speaking, the PWM is used in one of two categories of operation:

- **Unsynchronized.** The PWM generator and its two output signals are used alone, independent of other PWM generators.
- **Synchronized.** The PWM generator and its two outputs signals are used in conjunction with other PWM generators using a common, unified time base. If multiple PWM generators are configured with the same counter load value, synchronization can be used to guarantee that they also have the same count value (the PWM generators must be configured before they are synchronized). With this feature, more than two $MnPWMn$ signals can be produced with a known relationship between the edges of those signals because the counters always have the same values. Other states in the module provide mechanisms to maintain the common time base and mutual synchronization.

The counter in a PWM generator can be reset to zero by writing the **PWM Time Base Sync (PWMSYNC)** register and setting the $SYNCn$ bit associated with the generator. Multiple PWM generators can be synchronized together by setting all necessary $SYNCn$ bits in one access. For example, setting the $SYNC0$ and $SYNC1$ bits in the **PWMSYNC** register causes the counters in PWM generators 0 and 1 to reset together.

Additional synchronization can occur between multiple PWM generators by updating register contents in one of the following three ways:

- **Immediately.** The write value has immediate effect, and the hardware reacts immediately.
- **Locally Synchronized.** The write value does not affect the logic until the counter reaches the value zero at the end of the PWM cycle. In this case, the effect of the write is deferred, providing a guaranteed defined behavior and preventing overly short or overly long output PWM pulses.
- **Globally Synchronized.** The write value does not affect the logic until two sequential events have occurred: (1) the Update mode for the generator function is programmed for global synchronization in the **PWMnCTL** register, and (2) the counter reaches zero at the end of the PWM cycle. In this case, the effect of the write is deferred until the end of the PWM cycle following the end of all updates. This mode allows multiple items in multiple PWM generators to be updated simultaneously without odd effects during the update; everything runs from the old values until a point at which they all run from the new values. The Update mode of the load and comparator match values can be individually configured in each PWM generator block. It typically makes sense to use the synchronous update mechanism across PWM generator blocks when the timers in those blocks are synchronized, although this is not required in order for this mechanism to function properly.

The following registers provide either local or global synchronization based on the state of various Update mode bits and fields in the **PWMnCTL** register ($LOADUPD$; $CMPAUPD$; $CMPBUPD$):

- Generator Registers: **PWMnLOAD**, **PWMnCMPA**, and **PWMnCMPB**

The following registers default to immediate update, but are provided with the optional functionality of synchronously updating rather than having all updates take immediate effect:

- Module-Level Register: **PWMENABLE** (based on the state of the `ENUPDn` bits in the `PWMENUPD` register).
- Generator Register: **PWMnGENA**, **PWMnGENB**, **PWMnDBCTL**, **PWMnDBRISE**, and **PWMnDBFALL** (based on the state of various Update mode bits and fields in the **PWMnCTL** register (`GENAUPD`; `GENBUPD`; `DBCTLUPD`; `DBRISEUPD`; `DBFALLUPD`)).

All other registers are considered statically provisioned for the execution of an application or are used dynamically for purposes unrelated to maintaining synchronization and therefore do not need synchronous update functionality.

26.3.8 Fault Conditions

A fault condition is one in which the controller must be signaled to stop normal PWM function and then set the `MnPWMn` signals to a safe state. Two basic situations cause fault conditions:

- The microcontroller is stalled and cannot perform the necessary computation in the time required for motion control
- An external error or event is detected

The PWM generator can use the following inputs to generate a fault condition, including:

- `MnFAULTn` pin assertion
- A stall of the controller generated by the debugger
- The trigger of an ADC digital comparator

Fault conditions are calculated on a per-PWM generator basis. Each PWM generator configures the necessary conditions to indicate a fault condition exists. This method allows the development of applications with dependent and independent control.

Four fault input pins (`MnFAULTn`) are available. These inputs may be used with circuits that generate an active High or active Low signal to indicate an error condition. A `MnFAULTn` pins may be individually programmed for the appropriate logic sense using the **PWMnFLTSEN** register.

The PWM generator's mode control, including fault condition handling, is provided in the **PWMnCTL** register. This register determines whether the input or a combination of `MnFAULTn` input signals and/or digital comparator triggers (as configured by the **PWMnFLTSRC0** and **PWMnFLTSRC1** registers) is used to generate a fault condition. The **PWMnCTL** register also selects whether the fault condition is maintained as long as the external condition lasts or if it is latched until the fault condition until cleared by software. Finally, this register also enables a counter that may be used to extend the period of a fault condition for external events to assure that the duration is a minimum length. The minimum fault period count is specified in the **PWMnMINFLTPER** register.

Note: When using an ADC digital comparator as a fault source, the `LATCH` and `MINFLTPER` bits in the **PWMnCTL** register should be set to 1 to ensure trigger assertions are captured.

Status regarding the specific fault cause is provided in the **PWMnFLTSTAT0** and **PWMnFLTSTAT1** registers. Note that the fault status registers, **PWMnFLTSTAT0** and **PWMnFLTSTAT1**, reflect the status of all fault sources, regardless of what fault sources are enabled for that particular generator.

PWM generator fault conditions may be promoted to a controller interrupt using the **PWMINTEN** register.

26.3.9 Output Control Block

The output control block takes care of the final conditioning of the `pwmA'` and `pwmB'` signals before they go to the pins as the `MnPWMn` signals. Via a single register, the **PWM Output Enable (PWENABLE)** register, the set of PWM signals that are actually enabled to the pins can be modified. This function can be used, for example, to perform commutation of a brushless DC motor with a single register write (and without modifying the individual PWM generators, which are modified by the feedback control loop). In addition, the updating of the bits in the **PWMENABLE** register can be configured to be immediate or locally or globally synchronized to the next synchronous update using the **PWM Enable Update (PWMENUUPD)** register.

During fault conditions, the PWM output signals, `MnPWMn`, usually must be driven to safe values so that external equipment may be safely controlled. The **PWMFAULT** register specifies whether during a fault condition, the generated signal continues to be passed driven or to an encoding specified in the **PWMFAULTVAL** register.

A final inversion can be applied to any of the `MnPWMn` signals, making them active Low instead of the default active High using the **PWM Output Inversion (PWMINVERT)**. The inversion is applied even if a value has been enabled in the **PWMFAULT** register and specified in the **PWMFAULTVAL** register. In other words, if a bit is set in the **PWMFAULT**, **PWMFAULTVAL**, and **PWMINVERT** registers, the output on the `MnPWMn` signal is 0, not 1 as specified in the **PWMFAULTVAL** register.

26.4 Initialization and Configuration

The following example shows how to initialize PWM Generator 0 with a 25-kHz frequency, a 25% duty cycle on the `MnPWM0` pin, and a 75% duty cycle on the `MnPWM1` pin. This example assumes the system clock is 20 MHz.

1. Enable the PWM clock by setting its corresponding bit in the **RCGCPWM** register in the System Control module (see page 405).
2. Enable the clock to the appropriate GPIO module via the **RCGCGPIO** register in the System Control module (see page 389).
3. In the GPIO module, enable the appropriate pins for their alternate function using the **GPIOAFSEL** register. To determine which GPIOs to configure, see Table 29-4 on page 1921.
4. Configure the `PMCn` fields in the **GPIOPCTL** register to assign the PWM signals to the appropriate pins (see page 795 and Table 29-5 on page 1932).
5. Configure the **PWM Clock Configuration (PWMCC)** register to use the PWM divide (`USEPWMDIV`) and set the divider (`PWMDIV`) to divide by 2 (0x0).
6. Configure the PWM generator for countdown mode with immediate updates to the parameters.
 - Write the **PWM0CTL** register with a value of 0x0000.0000.
 - Write the **PWM0GENA** register with a value of 0x0000.008C.
 - Write the **PWM0GENB** register with a value of 0x0000.080C.
7. Set the period. For a 25-KHz frequency, the period = 1/25,000, or 40 microseconds. The PWM clock source is 10 MHz; the system clock divided by 2. Thus there are 400 clock ticks per period. Use this value to set the **PWM0LOAD** register. In Count-Down mode, set the `LOAD` field in the **PWM0LOAD** register to the requested period minus one.

- Write the **PWM0LOAD** register with a value of 0x0000.018F.
8. Set the pulse width of the M_n PWM0 pin for a 25% duty cycle.
 - Write the **PWM0CMPA** register with a value of 0x0000.012B.
 9. Set the pulse width of the M_n PWM1 pin for a 75% duty cycle.
 - Write the **PWM0CMPB** register with a value of 0x0000.0063.
 10. Start the timers in PWM generator 0.
 - Write the **PWM0CTL** register with a value of 0x0000.0001.
 11. Enable PWM outputs.
 - Write the **PWMENABLE** register with a value of 0x0000.0003.

26.5 Register Map

Table 26-2 on page 1803 lists the PWM registers. The offset listed is a hexadecimal increment to the register's address, relative to the PWM module's base address:

- PWM0: 0x4002.8000

Note that the PWM module clock must be enabled before the registers can be programmed. There must be a delay of 3 system clocks after the PWM module clock is enabled before any PWM module registers are accessed.

Table 26-2. PWM Register Map

Offset	Name	Type	Reset	Description	See page
0x000	PWMCTL	RW	0x0000.0000	PWM Master Control	1807
0x004	PWMSYNC	RW	0x0000.0000	PWM Time Base Sync	1809
0x008	PWMENABLE	RW	0x0000.0000	PWM Output Enable	1810
0x00C	PWMINVERT	RW	0x0000.0000	PWM Output Inversion	1812
0x010	PWMFAULT	RW	0x0000.0000	PWM Output Fault	1814
0x014	PWMINTEN	RW	0x0000.0000	PWM Interrupt Enable	1816
0x018	PWMRIS	RO	0x0000.0000	PWM Raw Interrupt Status	1818
0x01C	PWMISC	RW1C	0x0000.0000	PWM Interrupt Status and Clear	1821
0x020	PWMSTATUS	RO	0x0000.0000	PWM Status	1824
0x024	PWMFAULTVAL	RW	0x0000.0000	PWM Fault Condition Value	1826
0x028	PWMENUPD	RW	0x0000.0000	PWM Enable Update	1828
0x040	PWM0CTL	RW	0x0000.0000	PWM0 Control	1832
0x044	PWM0INTEN	RW	0x0000.0000	PWM0 Interrupt and Trigger Enable	1837
0x048	PWM0RIS	RO	0x0000.0000	PWM0 Raw Interrupt Status	1840

Table 26-2. PWM Register Map (continued)

Offset	Name	Type	Reset	Description	See page
0x04C	PWM0ISC	RW1C	0x0000.0000	PWM0 Interrupt Status and Clear	1842
0x050	PWM0LOAD	RW	0x0000.0000	PWM0 Load	1844
0x054	PWM0COUNT	RO	0x0000.0000	PWM0 Counter	1845
0x058	PWM0CMPA	RW	0x0000.0000	PWM0 Compare A	1846
0x05C	PWM0CMPB	RW	0x0000.0000	PWM0 Compare B	1847
0x060	PWM0GENA	RW	0x0000.0000	PWM0 Generator A Control	1848
0x064	PWM0GENB	RW	0x0000.0000	PWM0 Generator B Control	1851
0x068	PWM0DBCTL	RW	0x0000.0000	PWM0 Dead-Band Control	1854
0x06C	PWM0DBRISE	RW	0x0000.0000	PWM0 Dead-Band Rising-Edge Delay	1855
0x070	PWM0DBFALL	RW	0x0000.0000	PWM0 Dead-Band Falling-Edge-Delay	1856
0x074	PWM0FLTSRC0	RW	0x0000.0000	PWM0 Fault Source 0	1857
0x078	PWM0FLTSRC1	RW	0x0000.0000	PWM0 Fault Source 1	1859
0x07C	PWM0MINFLTPER	RW	0x0000.0000	PWM0 Minimum Fault Period	1862
0x080	PWM1CTL	RW	0x0000.0000	PWM1 Control	1832
0x084	PWM1INTEN	RW	0x0000.0000	PWM1 Interrupt and Trigger Enable	1837
0x088	PWM1RIS	RO	0x0000.0000	PWM1 Raw Interrupt Status	1840
0x08C	PWM1ISC	RW1C	0x0000.0000	PWM1 Interrupt Status and Clear	1842
0x090	PWM1LOAD	RW	0x0000.0000	PWM1 Load	1844
0x094	PWM1COUNT	RO	0x0000.0000	PWM1 Counter	1845
0x098	PWM1CMPA	RW	0x0000.0000	PWM1 Compare A	1846
0x09C	PWM1CMPB	RW	0x0000.0000	PWM1 Compare B	1847
0x0A0	PWM1GENA	RW	0x0000.0000	PWM1 Generator A Control	1848
0x0A4	PWM1GENB	RW	0x0000.0000	PWM1 Generator B Control	1851
0x0A8	PWM1DBCTL	RW	0x0000.0000	PWM1 Dead-Band Control	1854
0x0AC	PWM1DBRISE	RW	0x0000.0000	PWM1 Dead-Band Rising-Edge Delay	1855
0x0B0	PWM1DBFALL	RW	0x0000.0000	PWM1 Dead-Band Falling-Edge-Delay	1856
0x0B4	PWM1FLTSRC0	RW	0x0000.0000	PWM1 Fault Source 0	1857
0x0B8	PWM1FLTSRC1	RW	0x0000.0000	PWM1 Fault Source 1	1859
0x0BC	PWM1MINFLTPER	RW	0x0000.0000	PWM1 Minimum Fault Period	1862
0x0C0	PWM2CTL	RW	0x0000.0000	PWM2 Control	1832
0x0C4	PWM2INTEN	RW	0x0000.0000	PWM2 Interrupt and Trigger Enable	1837
0x0C8	PWM2RIS	RO	0x0000.0000	PWM2 Raw Interrupt Status	1840

Table 26-2. PWM Register Map (continued)

Offset	Name	Type	Reset	Description	See page
0x0CC	PWM2ISC	RW1C	0x0000.0000	PWM2 Interrupt Status and Clear	1842
0x0D0	PWM2LOAD	RW	0x0000.0000	PWM2 Load	1844
0x0D4	PWM2COUNT	RO	0x0000.0000	PWM2 Counter	1845
0x0D8	PWM2CMPA	RW	0x0000.0000	PWM2 Compare A	1846
0x0DC	PWM2CMPB	RW	0x0000.0000	PWM2 Compare B	1847
0x0E0	PWM2GENA	RW	0x0000.0000	PWM2 Generator A Control	1848
0x0E4	PWM2GENB	RW	0x0000.0000	PWM2 Generator B Control	1851
0x0E8	PWM2DBCTL	RW	0x0000.0000	PWM2 Dead-Band Control	1854
0x0EC	PWM2DBRISE	RW	0x0000.0000	PWM2 Dead-Band Rising-Edge Delay	1855
0x0F0	PWM2DBFALL	RW	0x0000.0000	PWM2 Dead-Band Falling-Edge-Delay	1856
0x0F4	PWM2FLTSRC0	RW	0x0000.0000	PWM2 Fault Source 0	1857
0x0F8	PWM2FLTSRC1	RW	0x0000.0000	PWM2 Fault Source 1	1859
0x0FC	PWM2MINFLTPER	RW	0x0000.0000	PWM2 Minimum Fault Period	1862
0x100	PWM3CTL	RW	0x0000.0000	PWM3 Control	1832
0x104	PWM3INTEN	RW	0x0000.0000	PWM3 Interrupt and Trigger Enable	1837
0x108	PWM3RIS	RO	0x0000.0000	PWM3 Raw Interrupt Status	1840
0x10C	PWM3ISC	RW1C	0x0000.0000	PWM3 Interrupt Status and Clear	1842
0x110	PWM3LOAD	RW	0x0000.0000	PWM3 Load	1844
0x114	PWM3COUNT	RO	0x0000.0000	PWM3 Counter	1845
0x118	PWM3CMPA	RW	0x0000.0000	PWM3 Compare A	1846
0x11C	PWM3CMPB	RW	0x0000.0000	PWM3 Compare B	1847
0x120	PWM3GENA	RW	0x0000.0000	PWM3 Generator A Control	1848
0x124	PWM3GENB	RW	0x0000.0000	PWM3 Generator B Control	1851
0x128	PWM3DBCTL	RW	0x0000.0000	PWM3 Dead-Band Control	1854
0x12C	PWM3DBRISE	RW	0x0000.0000	PWM3 Dead-Band Rising-Edge Delay	1855
0x130	PWM3DBFALL	RW	0x0000.0000	PWM3 Dead-Band Falling-Edge-Delay	1856
0x134	PWM3FLTSRC0	RW	0x0000.0000	PWM3 Fault Source 0	1857
0x138	PWM3FLTSRC1	RW	0x0000.0000	PWM3 Fault Source 1	1859
0x13C	PWM3MINFLTPER	RW	0x0000.0000	PWM3 Minimum Fault Period	1862
0x800	PWM0FLTSEN	RW	0x0000.0000	PWM0 Fault Pin Logic Sense	1863
0x804	PWM0FLTSTAT0	-	0x0000.0000	PWM0 Fault Status 0	1864
0x808	PWM0FLTSTAT1	-	0x0000.0000	PWM0 Fault Status 1	1866

Table 26-2. PWM Register Map (continued)

Offset	Name	Type	Reset	Description	See page
0x880	PWM1FLTSEN	RW	0x0000.0000	PWM1 Fault Pin Logic Sense	1863
0x884	PWM1FLTSTAT0	-	0x0000.0000	PWM1 Fault Status 0	1864
0x888	PWM1FLTSTAT1	-	0x0000.0000	PWM1 Fault Status 1	1866
0x900	PWM2FLTSEN	RW	0x0000.0000	PWM2 Fault Pin Logic Sense	1863
0x904	PWM2FLTSTAT0	-	0x0000.0000	PWM2 Fault Status 0	1864
0x908	PWM2FLTSTAT1	-	0x0000.0000	PWM2 Fault Status 1	1866
0x980	PWM3FLTSEN	RW	0x0000.0000	PWM3 Fault Pin Logic Sense	1863
0x984	PWM3FLTSTAT0	-	0x0000.0000	PWM3 Fault Status 0	1864
0x988	PWM3FLTSTAT1	-	0x0000.0000	PWM3 Fault Status 1	1866
0xFC0	PWMPP	RO	0x0000.0344	PWM Peripheral Properties	1869
0xFC8	PWMCC	RW	0x0000.0005	PWM Clock Configuration	1871

26.6 Register Descriptions

The remainder of this section lists and describes the PWM registers, in numerical order by address offset.

Register 1: PWM Master Control (PWMCTL), offset 0x000

This register provides master control over the PWM generation blocks.

PWM Master Control (PWMCTL)

PWM0 base: 0x4002.8000

Offset 0x000

Type RW, reset 0x0000.0000

	31	30	29	28	27	26	25	24	23	22	21	20	19	18	17	16	
	reserved																
Type	RO	RO	RO	RO	RO	RO	RO	RO	RO	RO	RO	RO	RO	RO	RO	RO	
Reset	0	0	0	0	0	0	0	0	0	0	0	0	0	0	0	0	
	15	14	13	12	11	10	9	8	7	6	5	4	3	2	1	0	
	reserved												GLOBALSYNC3	GLOBALSYNC2	GLOBALSYNC1	GLOBALSYNC0	
Type	RO	RO	RO	RO	RO	RO	RO	RO	RO	RO	RO	RO	RO	RW	RW	RW	RW
Reset	0	0	0	0	0	0	0	0	0	0	0	0	0	0	0	0	0

Bit/Field	Name	Type	Reset	Description
31:4	reserved	RO	0x0000	Software should not rely on the value of a reserved bit. To provide compatibility with future products, the value of a reserved bit should be preserved across a read-modify-write operation.
3	GLOBALSYNC3	RW	0	Update PWM Generator 3 Value Description 0 No effect. 1 Any queued update to a load or comparator register in PWM generator 3 is applied the next time the corresponding counter becomes zero. This bit automatically clears when the updates have completed; it cannot be cleared by software.
2	GLOBALSYNC2	RW	0	Update PWM Generator 2 Value Description 0 No effect. 1 Any queued update to a load or comparator register in PWM generator 2 is applied the next time the corresponding counter becomes zero. This bit automatically clears when the updates have completed; it cannot be cleared by software.

Bit/Field	Name	Type	Reset	Description
1	GLOBALSYNC1	RW	0	<p>Update PWM Generator 1</p> <p>Value Description</p> <p>0 No effect.</p> <p>1 Any queued update to a load or comparator register in PWM generator 1 is applied the next time the corresponding counter becomes zero.</p> <p>This bit automatically clears when the updates have completed; it cannot be cleared by software.</p>
0	GLOBALSYNC0	RW	0	<p>Update PWM Generator 0</p> <p>Value Description</p> <p>0 No effect.</p> <p>1 Any queued update to a load or comparator register in PWM generator 0 is applied the next time the corresponding counter becomes zero.</p> <p>This bit automatically clears when the updates have completed; it cannot be cleared by software.</p>

Register 2: PWM Time Base Sync (PWMSYNC), offset 0x004

This register provides a method to perform synchronization of the counters in the PWM generation blocks. Setting a bit in this register causes the specified counter to reset back to 0; setting multiple bits resets multiple counters simultaneously. The bits auto-clear after the reset has occurred; reading them back as zero indicates that the synchronization has completed.

PWM Time Base Sync (PWMSYNC)

PWM0 base: 0x4002.8000

Offset 0x004

Type RW, reset 0x0000.0000

	31	30	29	28	27	26	25	24	23	22	21	20	19	18	17	16	
	reserved																
Type	RO	RO	RO	RO	RO	RO	RO	RO	RO	RO	RO	RO	RO	RO	RO	RO	
Reset	0	0	0	0	0	0	0	0	0	0	0	0	0	0	0	0	
	15	14	13	12	11	10	9	8	7	6	5	4	3	2	1	0	
	reserved												SYNC3	SYNC2	SYNC1	SYNC0	
Type	RO	RO	RO	RO	RO	RO	RO	RO	RO	RO	RO	RO	RO	RW	RW	RW	RW
Reset	0	0	0	0	0	0	0	0	0	0	0	0	0	0	0	0	0

Bit/Field	Name	Type	Reset	Description
31:4	reserved	RO	0x0000.000	Software should not rely on the value of a reserved bit. To provide compatibility with future products, the value of a reserved bit should be preserved across a read-modify-write operation.
3	SYNC3	RW	0	Reset Generator 3 Counter Value Description 0 No effect. 1 Resets the PWM generator 3 counter.
2	SYNC2	RW	0	Reset Generator 2 Counter Value Description 0 No effect. 1 Resets the PWM generator 2 counter.
1	SYNC1	RW	0	Reset Generator 1 Counter Value Description 0 No effect. 1 Resets the PWM generator 1 counter.
0	SYNC0	RW	0	Reset Generator 0 Counter Value Description 0 No effect. 1 Resets the PWM generator 0 counter.

Register 3: PWM Output Enable (PWMENABLE), offset 0x008

This register provides a master control of which generated pwmA' and pwmB' signals are output to the M_nPWM_n pins. By disabling a PWM output, the generation process can continue (for example, when the time bases are synchronized) without driving PWM signals to the pins. When bits in this register are set, the corresponding pwmA' or pwmB' signal is passed through to the output stage. When bits are clear, the pwmA' or pwmB' signal is replaced by a zero value which is also passed to the output stage. The **PWMINVERT** register controls the output stage, so if the corresponding bit is set in that register, the value seen on the M_nPWM_n signal is inverted from what is configured by the bits in this register. Updates to the bits in this register can be immediate or locally or globally synchronized to the next synchronous update as controlled by the $ENUPD_n$ fields in the **PWMENUPD** register.

PWM Output Enable (PWMENABLE)

PWM0 base: 0x4002.8000
 Offset 0x008
 Type RW, reset 0x0000.0000

	31	30	29	28	27	26	25	24	23	22	21	20	19	18	17	16
	reserved															
Type	RO	RO	RO	RO	RO	RO	RO	RO	RO	RO	RO	RO	RO	RO	RO	RO
Reset	0	0	0	0	0	0	0	0	0	0	0	0	0	0	0	0
	15	14	13	12	11	10	9	8	7	6	5	4	3	2	1	0
	reserved								PWM7EN	PWM6EN	PWM5EN	PWM4EN	PWM3EN	PWM2EN	PWM1EN	PWM0EN
Type	RO	RO	RO	RO	RO	RO	RO	RO	RW	RW	RW	RW	RW	RW	RW	RW
Reset	0	0	0	0	0	0	0	0	0	0	0	0	0	0	0	0

Bit/Field	Name	Type	Reset	Description
31:8	reserved	RO	0x0000.00	Software should not rely on the value of a reserved bit. To provide compatibility with future products, the value of a reserved bit should be preserved across a read-modify-write operation.
7	PWM7EN	RW	0	M_nPWM_7 Output Enable Value Description 0 The M_nPWM_7 signal has a zero value. 1 The generated pwm3B' signal is passed to the M_nPWM_7 pin.
6	PWM6EN	RW	0	M_nPWM_6 Output Enable Value Description 0 The M_nPWM_6 signal has a zero value. 1 The generated pwm3A' signal is passed to the M_nPWM_6 pin.
5	PWM5EN	RW	0	M_nPWM_5 Output Enable Value Description 0 The M_nPWM_5 signal has a zero value. 1 The generated pwm2B' signal is passed to the M_nPWM_5 pin.

Bit/Field	Name	Type	Reset	Description
4	PWM4EN	RW	0	MnPWM4 Output Enable Value Description 0 The MnPWM4 signal has a zero value. 1 The generated pwm2A' signal is passed to the MnPWM4 pin.
3	PWM3EN	RW	0	MnPWM3 Output Enable Value Description 0 The MnPWM3 signal has a zero value. 1 The generated pwm1B' signal is passed to the MnPWM3 pin.
2	PWM2EN	RW	0	MnPWM2 Output Enable Value Description 0 The MnPWM2 signal has a zero value. 1 The generated pwm1A' signal is passed to the MnPWM2 pin.
1	PWM1EN	RW	0	MnPWM1 Output Enable Value Description 0 The MnPWM1 signal has a zero value. 1 The generated pwm0B' signal is passed to the MnPWM1 pin.
0	PWM0EN	RW	0	MnPWM0 Output Enable Value Description 0 The MnPWM0 signal has a zero value. 1 The generated pwm0A' signal is passed to the MnPWM0 pin.

Register 4: PWM Output Inversion (PWMINVERT), offset 0x00C

This register provides a master control of the polarity of the M_nPWM_n signals on the device pins. The $pwmA'$ and $pwmB'$ signals generated by the PWM generator are active High; but can be made active Low via this register. Disabled PWM channels are also passed through the output inverter (if so configured) so that inactive signals can be High. In addition, if the **PWMFAULT** register enables a specific value to be placed on the M_nPWM_n signals during a fault condition, that value is inverted if the corresponding bit in this register is set.

PWM Output Inversion (PWMINVERT)

PWM0 base: 0x4002.8000
 Offset 0x00C
 Type RW, reset 0x0000.0000

	31	30	29	28	27	26	25	24	23	22	21	20	19	18	17	16
	reserved															
Type	RO	RO	RO	RO	RO	RO	RO	RO	RO	RO	RO	RO	RO	RO	RO	RO
Reset	0	0	0	0	0	0	0	0	0	0	0	0	0	0	0	0
	15	14	13	12	11	10	9	8	7	6	5	4	3	2	1	0
	reserved								PWM7INV	PWM6INV	PWM5INV	PWM4INV	PWM3INV	PWM2INV	PWM1INV	PWM0INV
Type	RO	RO	RO	RO	RO	RO	RO	RO	RW	RW	RW	RW	RW	RW	RW	RW
Reset	0	0	0	0	0	0	0	0	0	0	0	0	0	0	0	0

Bit/Field	Name	Type	Reset	Description
31:8	reserved	RO	0x0000.00	Software should not rely on the value of a reserved bit. To provide compatibility with future products, the value of a reserved bit should be preserved across a read-modify-write operation.
7	PWM7INV	RW	0	Invert M_nPWM_7 Signal Value Description 0 The M_nPWM_7 signal is not inverted. 1 The M_nPWM_7 signal is inverted.
6	PWM6INV	RW	0	Invert M_nPWM_6 Signal Value Description 0 The M_nPWM_6 signal is not inverted. 1 The M_nPWM_6 signal is inverted.
5	PWM5INV	RW	0	Invert M_nPWM_5 Signal Value Description 0 The M_nPWM_5 signal is not inverted. 1 The M_nPWM_5 signal is inverted.
4	PWM4INV	RW	0	Invert M_nPWM_4 Signal Value Description 0 The M_nPWM_4 signal is not inverted. 1 The M_nPWM_4 signal is inverted.

Bit/Field	Name	Type	Reset	Description
3	PWM3INV	RW	0	Invert M _n PWM3 Signal Value Description 0 The M _n PWM3 signal is not inverted. 1 The M _n PWM3 signal is inverted.
2	PWM2INV	RW	0	Invert M _n PWM2 Signal Value Description 0 The M _n PWM2 signal is not inverted. 1 The M _n PWM2 signal is inverted.
1	PWM1INV	RW	0	Invert M _n PWM1 Signal Value Description 0 The M _n PWM1 signal is not inverted. 1 The M _n PWM1 signal is inverted.
0	PWM0INV	RW	0	Invert M _n PWM0 Signal Value Description 0 The M _n PWM0 signal is not inverted. 1 The M _n PWM0 signal is inverted.

Register 5: PWM Output Fault (PWMFAULT), offset 0x010

This register controls the behavior of the M_nPWM_n outputs in the presence of fault conditions. Both the fault inputs (M_nFAULT_n pins and digital comparator outputs) and debug events are considered fault conditions. On a fault condition, each pwmA' or pwmB' signal can be passed through unmodified or driven to the value specified by the corresponding bit in the **PWMFAULTVAL** register. For outputs that are configured for pass-through, the debug event handling on the corresponding PWM generator also determines if the pwmA' or pwmB' signal continues to be generated.

Fault condition control occurs before the output inverter, so PWM signals driven to a specified value on fault are inverted if the channel is configured for inversion (therefore, the pin is driven to the logical complement of the specified value on a fault condition).

PWM Output Fault (PWMFAULT)

PWM0 base: 0x4002.8000
 Offset 0x010
 Type RW, reset 0x0000.0000

	31	30	29	28	27	26	25	24	23	22	21	20	19	18	17	16
	reserved															
Type	RO	RO	RO	RO	RO	RO	RO	RO	RO	RO	RO	RO	RO	RO	RO	RO
Reset	0	0	0	0	0	0	0	0	0	0	0	0	0	0	0	0
	15	14	13	12	11	10	9	8	7	6	5	4	3	2	1	0
	reserved								FAULT7	FAULT6	FAULT5	FAULT4	FAULT3	FAULT2	FAULT1	FAULT0
Type	RO	RO	RO	RO	RO	RO	RO	RO	RW	RW	RW	RW	RW	RW	RW	RW
Reset	0	0	0	0	0	0	0	0	0	0	0	0	0	0	0	0

Bit/Field	Name	Type	Reset	Description
31:8	reserved	RO	0x0000.00	Software should not rely on the value of a reserved bit. To provide compatibility with future products, the value of a reserved bit should be preserved across a read-modify-write operation.
7	FAULT7	RW	0	<p>M_nPWM7 Fault</p> <p>Value Description</p> <p>0 The generated pwm3B' signal is passed to the M_nPWM7 pin.</p> <p>1 The M_nPWM7 output signal is driven to the value specified by the $PWM7$ bit in the PWMFAULTVAL register.</p>
6	FAULT6	RW	0	<p>M_nPWM6 Fault</p> <p>Value Description</p> <p>0 The generated pwm3A' signal is passed to the M_nPWM6 pin.</p> <p>1 The M_nPWM6 output signal is driven to the value specified by the $PWM6$ bit in the PWMFAULTVAL register.</p>
5	FAULT5	RW	0	<p>M_nPWM5 Fault</p> <p>Value Description</p> <p>0 The generated pwm2B' signal is passed to the M_nPWM5 pin.</p> <p>1 The M_nPWM5 output signal is driven to the value specified by the $PWM5$ bit in the PWMFAULTVAL register.</p>

Bit/Field	Name	Type	Reset	Description
4	FAULT4	RW	0	<p>MnPWM4 Fault</p> <p>Value Description</p> <p>0 The generated pwm2A' signal is passed to the MnPWM4 pin.</p> <p>1 The MnPWM4 output signal is driven to the value specified by the PWM4 bit in the PWMFAULTVAL register.</p>
3	FAULT3	RW	0	<p>MnPWM3 Fault</p> <p>Value Description</p> <p>0 The generated pwm1B' signal is passed to the MnPWM3 pin.</p> <p>1 The MnPWM3 output signal is driven to the value specified by the PWM3 bit in the PWMFAULTVAL register.</p>
2	FAULT2	RW	0	<p>MnPWM2 Fault</p> <p>Value Description</p> <p>0 The generated pwm1A' signal is passed to the MnPWM2 pin.</p> <p>1 The MnPWM2 output signal is driven to the value specified by the PWM2 bit in the PWMFAULTVAL register.</p>
1	FAULT1	RW	0	<p>MnPWM1 Fault</p> <p>Value Description</p> <p>0 The generated pwm0B' signal is passed to the MnPWM1 pin.</p> <p>1 The MnPWM1 output signal is driven to the value specified by the PWM1 bit in the PWMFAULTVAL register.</p>
0	FAULT0	RW	0	<p>MnPWM0 Fault</p> <p>Value Description</p> <p>0 The generated pwm0A' signal is passed to the MnPWM0 pin.</p> <p>1 The MnPWM0 output signal is driven to the value specified by the PWM0 bit in the PWMFAULTVAL register.</p>

Register 6: PWM Interrupt Enable (PWMINTEN), offset 0x014

This register controls the global interrupt generation capabilities of the PWM module. The events that can cause an interrupt are the fault input and the individual interrupts from the PWM generators.

Note: The "n" in the INTFAULT_n and INTPWM_n bits in this register correspond to the PWM generators, not to the FAULT_n signals.

PWM Interrupt Enable (PWMINTEN)

PWM0 base: 0x4002.8000
 Offset 0x014
 Type RW, reset 0x0000.0000

	31	30	29	28	27	26	25	24	23	22	21	20	19	18	17	16
	reserved												INTFAULT3	INTFAULT2	INTFAULT1	INTFAULT0
Type	RO	RO	RO	RO	RO	RO	RO	RO	RO	RO	RO	RO	RW	RW	RW	RW
Reset	0	0	0	0	0	0	0	0	0	0	0	0	0	0	0	0
	15	14	13	12	11	10	9	8	7	6	5	4	3	2	1	0
	reserved												INTPWM3	INTPWM2	INTPWM1	INTPWM0
Type	RO	RO	RO	RO	RO	RO	RO	RO	RO	RO	RO	RO	RW	RW	RW	RW
Reset	0	0	0	0	0	0	0	0	0	0	0	0	0	0	0	0

Bit/Field	Name	Type	Reset	Description
31:20	reserved	RO	0x000	Software should not rely on the value of a reserved bit. To provide compatibility with future products, the value of a reserved bit should be preserved across a read-modify-write operation.
19	INTFAULT3	RW	0	Interrupt Fault 3 Value Description 0 The fault condition for PWM generator 3 is suppressed and not sent to the interrupt controller. 1 An interrupt is sent to the interrupt controller when the fault condition for PWM generator 3 is asserted.
18	INTFAULT2	RW	0	Interrupt Fault 2 Value Description 0 The fault condition for PWM generator 2 is suppressed and not sent to the interrupt controller. 1 An interrupt is sent to the interrupt controller when the fault condition for PWM generator 2 is asserted.
17	INTFAULT1	RW	0	Interrupt Fault 1 Value Description 0 The fault condition for PWM generator 1 is suppressed and not sent to the interrupt controller. 1 An interrupt is sent to the interrupt controller when the fault condition for PWM generator 1 is asserted.

Bit/Field	Name	Type	Reset	Description
16	INTFAULT0	RW	0	<p>Interrupt Fault 0</p> <p>Value Description</p> <p>0 The fault condition for PWM generator 0 is suppressed and not sent to the interrupt controller.</p> <p>1 An interrupt is sent to the interrupt controller when the fault condition for PWM generator 0 is asserted.</p>
15:4	reserved	RO	0x000	Software should not rely on the value of a reserved bit. To provide compatibility with future products, the value of a reserved bit should be preserved across a read-modify-write operation.
3	INTPWM3	RW	0	<p>PWM3 Interrupt Enable</p> <p>Value Description</p> <p>0 The PWM generator 3 interrupt is suppressed and not sent to the interrupt controller.</p> <p>1 An interrupt is sent to the interrupt controller when the PWM generator 3 block asserts an interrupt.</p>
2	INTPWM2	RW	0	<p>PWM2 Interrupt Enable</p> <p>Value Description</p> <p>0 The PWM generator 2 interrupt is suppressed and not sent to the interrupt controller.</p> <p>1 An interrupt is sent to the interrupt controller when the PWM generator 2 block asserts an interrupt.</p>
1	INTPWM1	RW	0	<p>PWM1 Interrupt Enable</p> <p>Value Description</p> <p>0 The PWM generator 1 interrupt is suppressed and not sent to the interrupt controller.</p> <p>1 An interrupt is sent to the interrupt controller when the PWM generator 1 block asserts an interrupt.</p>
0	INTPWM0	RW	0	<p>PWM0 Interrupt Enable</p> <p>Value Description</p> <p>0 The PWM generator 0 interrupt is suppressed and not sent to the interrupt controller.</p> <p>1 An interrupt is sent to the interrupt controller when the PWM generator 0 block asserts an interrupt.</p>

Register 7: PWM Raw Interrupt Status (PWMRIS), offset 0x018

This register provides the current set of interrupt sources that are asserted, regardless of whether they are enabled to cause an interrupt to be asserted to the interrupt controller. The fault interrupt is asserted based on the fault condition source that is specified by the **PWMnCTL**, **PWMnFLTSRC0** and **PWMnFLTSRC1** registers. The fault interrupt is latched on detection and must be cleared through the **PWM Interrupt Status and Clear (PWMISC)** register. The actual value of the $M_nFAULTn$ signals can be observed using the **PWMSTATUS** register.

The PWM generator interrupts simply reflect the status of the PWM generators and are cleared via the interrupt status register in the PWM generator blocks. If a bit is set, the event is active; if a bit is clear the event is not active.

PWM Raw Interrupt Status (PWMRIS)

PWM0 base: 0x4002.8000
 Offset 0x018
 Type RO, reset 0x0000.0000

	31	30	29	28	27	26	25	24	23	22	21	20	19	18	17	16
	reserved												INTFAULT3	INTFAULT2	INTFAULT1	INTFAULT0
Type	RO	RO	RO	RO	RO	RO	RO	RO	RO	RO	RO	RO	RO	RO	RO	RO
Reset	0	0	0	0	0	0	0	0	0	0	0	0	0	0	0	0
	15	14	13	12	11	10	9	8	7	6	5	4	3	2	1	0
	reserved												INTPWM3	INTPWM2	INTPWM1	INTPWM0
Type	RO	RO	RO	RO	RO	RO	RO	RO	RO	RO	RO	RO	RO	RO	RO	RO
Reset	0	0	0	0	0	0	0	0	0	0	0	0	0	0	0	0

Bit/Field	Name	Type	Reset	Description
31:20	reserved	RO	0x000	Software should not rely on the value of a reserved bit. To provide compatibility with future products, the value of a reserved bit should be preserved across a read-modify-write operation.
19	INTFAULT3	RO	0	Interrupt Fault PWM 3 Value Description 0 The fault condition for PWM generator 3 has not been asserted. 1 The fault condition for PWM generator 3 is asserted. Note: If the LATCH bit is set in the PWM3CTL register, the INTFAULT3 bit in this register can be cleared by writing a 1 to the INTFAULT3 bit in the PWMISC register. If the LATCH bit is 0 in the PWM3CTL register, writing a 1 to the INTFAULT3 bit in the PWMISC register has no effect.
18	INTFAULT2	RO	0	Interrupt Fault PWM 2 Value Description 0 The fault condition for PWM generator 2 has not been asserted. 1 The fault condition for PWM generator 2 is asserted. Note: If the LATCH bit is set in the PWM2CTL register, the INTFAULT2 bit in this register can be cleared by writing a 1 to the INTFAULT2 bit in the PWMISC register. If the LATCH bit is 0 in the PWM2CTL register, writing a 1 to the INTFAULT2 bit in the PWMISC register has no effect.

Bit/Field	Name	Type	Reset	Description
17	INTFAULT1	RO	0	<p>Interrupt Fault PWM 1</p> <p>Value Description</p> <p>0 The fault condition for PWM generator 1 has not been asserted.</p> <p>1 The fault condition for PWM generator 1 is asserted.</p> <p>Note: If the LATCH bit is set in the PWM1CTL register, the INTFAULT1 bit in this register can be cleared by writing a 1 to the INTFAULT1 bit in the PWMISC register. If the LATCH bit is 0 in the PWM1CTL register, writing a 1 to the INTFAULT1 bit in the PWMISC register has no effect.</p>
16	INTFAULT0	RO	0	<p>Interrupt Fault PWM 0</p> <p>Value Description</p> <p>0 The fault condition for PWM generator 0 has not been asserted.</p> <p>1 The fault condition for PWM generator 0 is asserted.</p> <p>Note: If the LATCH bit is set in the PWM0CTL register, the INTFAULT0 bit in this register can be cleared by writing a 1 to the INTFAULT0 bit in the PWMISC register. If the LATCH bit is 0 in the PWM0CTL register, writing a 1 to the INTFAULT0 bit in the PWMISC register has no effect.</p>
15:4	reserved	RO	0x000	Software should not rely on the value of a reserved bit. To provide compatibility with future products, the value of a reserved bit should be preserved across a read-modify-write operation.
3	INTPWM3	RO	0	<p>PWM3 Interrupt Asserted</p> <p>Value Description</p> <p>0 The PWM generator 3 block interrupt has not been asserted.</p> <p>1 The PWM generator 3 block interrupt is asserted.</p> <p>The PWM3RIS register shows the source of this interrupt. This bit is cleared by writing a 1 to the corresponding bit in the PWM3ISC register.</p>
2	INTPWM2	RO	0	<p>PWM2 Interrupt Asserted</p> <p>Value Description</p> <p>0 The PWM generator 2 block interrupt has not been asserted.</p> <p>1 The PWM generator 2 block interrupt is asserted.</p> <p>The PWM2RIS register shows the source of this interrupt. This bit is cleared by writing a 1 to the corresponding bit in the PWM2ISC register.</p>
1	INTPWM1	RO	0	<p>PWM1 Interrupt Asserted</p> <p>Value Description</p> <p>0 The PWM generator 1 block interrupt has not been asserted.</p> <p>1 The PWM generator 1 block interrupt is asserted.</p> <p>The PWM1RIS register shows the source of this interrupt. This bit is cleared by writing a 1 to the corresponding bit in the PWM1ISC register.</p>

Bit/Field	Name	Type	Reset	Description
0	INTPWM0	RO	0	PWM0 Interrupt Asserted

Value Description

0 The PWM generator 0 block interrupt has not been asserted.

1 The PWM generator 0 block interrupt is asserted.

The **PWM0RIS** register shows the source of this interrupt. This bit is cleared by writing a 1 to the corresponding bit in the **PWM0ISC** register.

Register 8: PWM Interrupt Status and Clear (PWMISC), offset 0x01C

This register provides a summary of the interrupt status of the individual PWM generator blocks. If a fault interrupt is set, the corresponding M_nFAULT_n input has caused an interrupt. For the fault interrupt, a write of 1 to that bit position clears the latched interrupt status. If an block interrupt bit is set, the corresponding generator block is asserting an interrupt. The individual interrupt status registers, **PWMnISC**, in each block must be consulted to determine the reason for the interrupt and used to clear the interrupt.

PWM Interrupt Status and Clear (PWMISC)

PWM0 base: 0x4002.8000
Offset 0x01C
Type RW1C, reset 0x0000.0000

	31	30	29	28	27	26	25	24	23	22	21	20	19	18	17	16
	reserved												INTFAULT3	INTFAULT2	INTFAULT1	INTFAULT0
Type	RO	RO	RO	RO	RO	RO	RO	RO	RO	RO	RO	RO	RW1C	RW1C	RW1C	RW1C
Reset	0	0	0	0	0	0	0	0	0	0	0	0	0	0	0	0
	15	14	13	12	11	10	9	8	7	6	5	4	3	2	1	0
	reserved												INTPWM3	INTPWM2	INTPWM1	INTPWM0
Type	RO	RO	RO	RO	RO	RO	RO	RO	RO	RO	RO	RO	RO	RO	RO	RO
Reset	0	0	0	0	0	0	0	0	0	0	0	0	0	0	0	0

Bit/Field	Name	Type	Reset	Description
31:20	reserved	RO	0x000	Software should not rely on the value of a reserved bit. To provide compatibility with future products, the value of a reserved bit should be preserved across a read-modify-write operation.
19	INTFAULT3	RW1C	0	<p>FAULT3 Interrupt Asserted</p> <p>Value Description</p> <p>0 The fault condition for PWM generator 3 has not been asserted or is not enabled.</p> <p>1 An enabled interrupt for the fault condition for PWM generator 3 is asserted or is latched.</p> <p>Writing a 1 to this bit clears it and the INTFAULT3 bit in the PWMRIS register.</p>
18	INTFAULT2	RW1C	0	<p>FAULT2 Interrupt Asserted</p> <p>Value Description</p> <p>0 The fault condition for PWM generator 2 has not been asserted or is not enabled.</p> <p>1 An enabled interrupt for the fault condition for PWM generator 2 is asserted or is latched.</p> <p>Writing a 1 to this bit clears it and the INTFAULT2 bit in the PWMRIS register.</p>

Bit/Field	Name	Type	Reset	Description
17	INTFAULT1	RW1C	0	<p>FAULT1 Interrupt Asserted</p> <p>Value Description</p> <p>0 The fault condition for PWM generator 1 has not been asserted or is not enabled.</p> <p>1 An enabled interrupt for the fault condition for PWM generator 1 is asserted or is latched.</p> <p>Writing a 1 to this bit clears it and the INTFAULT1 bit in the PWMRIS register.</p>
16	INTFAULT0	RW1C	0	<p>FAULT0 Interrupt Asserted</p> <p>Value Description</p> <p>0 The fault condition for PWM generator 0 has not been asserted or is not enabled.</p> <p>1 An enabled interrupt for the fault condition for PWM generator 0 is asserted or is latched.</p> <p>Writing a 1 to this bit clears it and the INTFAULT0 bit in the PWMRIS register.</p>
15:4	reserved	RO	0x000	Software should not rely on the value of a reserved bit. To provide compatibility with future products, the value of a reserved bit should be preserved across a read-modify-write operation.
3	INTPWM3	RO	0	<p>PWM3 Interrupt Status</p> <p>Value Description</p> <p>0 The PWM generator 3 block interrupt is not asserted or is not enabled.</p> <p>1 An enabled interrupt for the PWM generator 3 block is asserted.</p> <p>The PWM3RIS register shows the source of this interrupt. This bit is cleared by writing a 1 to the corresponding bit in the PWM3ISC register.</p>
2	INTPWM2	RO	0	<p>PWM2 Interrupt Status</p> <p>Value Description</p> <p>0 The PWM generator 2 block interrupt is not asserted or is not enabled.</p> <p>1 An enabled interrupt for the PWM generator 2 block is asserted.</p> <p>The PWM2RIS register shows the source of this interrupt. This bit is cleared by writing a 1 to the corresponding bit in the PWM2ISC register.</p>
1	INTPWM1	RO	0	<p>PWM1 Interrupt Status</p> <p>Value Description</p> <p>0 The PWM generator 1 block interrupt is not asserted or is not enabled.</p> <p>1 An enabled interrupt for the PWM generator 1 block is asserted.</p> <p>The PWM1RIS register shows the source of this interrupt. This bit is cleared by writing a 1 to the corresponding bit in the PWM1ISC register.</p>

Bit/Field	Name	Type	Reset	Description
0	INTPWM0	RO	0	PWM0 Interrupt Status
				Value Description
			0	The PWM generator 0 block interrupt is not asserted or is not enabled.
			1	An enabled interrupt for the PWM generator 0 block is asserted.

The **PWM0RIS** register shows the source of this interrupt. This bit is cleared by writing a 1 to the corresponding bit in the **PWM0ISC** register.

Register 9: PWM Status (PWMSTATUS), offset 0x020

This register provides the unlatched status of the PWM generator fault condition.

PWM Status (PWMSTATUS)

PWM0 base: 0x4002.8000

Offset 0x020

Type RO, reset 0x0000.0000

	31	30	29	28	27	26	25	24	23	22	21	20	19	18	17	16
	reserved															
Type	RO	RO	RO	RO	RO	RO	RO	RO	RO	RO	RO	RO	RO	RO	RO	RO
Reset	0	0	0	0	0	0	0	0	0	0	0	0	0	0	0	0
	15	14	13	12	11	10	9	8	7	6	5	4	3	2	1	0
	reserved												FAULT3	FAULT2	FAULT1	FAULT0
Type	RO	RO	RO	RO	RO	RO	RO	RO	RO	RO	RO	RO	RO	RO	RO	RO
Reset	0	0	0	0	0	0	0	0	0	0	0	0	0	0	0	0

Bit/Field	Name	Type	Reset	Description
31:4	reserved	RO	0x0000.000	Software should not rely on the value of a reserved bit. To provide compatibility with future products, the value of a reserved bit should be preserved across a read-modify-write operation.
3	FAULT3	RO	0	Generator 3 Fault Status Value Description 0 The fault condition for PWM generator 3 is not asserted. 1 The fault condition for PWM generator 3 is asserted. If the FLTSRC bit in the PWM3CTL register is clear, the input is the source of the fault condition, and is therefore asserted.
2	FAULT2	RO	0	Generator 2 Fault Status Value Description 0 The fault condition for PWM generator 2 is not asserted. 1 The fault condition for PWM generator 2 is asserted. If the FLTSRC bit in the PWM2CTL register is clear, the input is the source of the fault condition, and is therefore asserted.
1	FAULT1	RO	0	Generator 1 Fault Status Value Description 0 The fault condition for PWM generator 1 is not asserted. 1 The fault condition for PWM generator 1 is asserted. If the FLTSRC bit in the PWM1CTL register is clear, the input is the source of the fault condition, and is therefore asserted.

Bit/Field	Name	Type	Reset	Description
0	FAULT0	RO	0	Generator 0 Fault Status
				Value Description
				0 The fault condition for PWM generator 0 is not asserted.
				1 The fault condition for PWM generator 0 is asserted. If the FLTSRC bit in the PWM0CTL register is clear, the input is the source of the fault condition, and is therefore asserted.

Register 10: PWM Fault Condition Value (PWMFAULTVAL), offset 0x024

This register specifies the output value driven on the M_nPWM_n signals during a fault condition if enabled by the corresponding bit in the **PWMFAULT** register. Note that if the corresponding bit in the **PWMINVERT** register is set, the output value is driven to the logical NOT of the bit value in this register.

PWM Fault Condition Value (PWMFAULTVAL)

PWM0 base: 0x4002.8000
 Offset 0x024
 Type RW, reset 0x0000.0000

	31	30	29	28	27	26	25	24	23	22	21	20	19	18	17	16
	reserved															
Type	RO	RO	RO	RO	RO	RO	RO	RO	RO	RO	RO	RO	RO	RO	RO	RO
Reset	0	0	0	0	0	0	0	0	0	0	0	0	0	0	0	0
	15	14	13	12	11	10	9	8	7	6	5	4	3	2	1	0
	reserved								PWM7	PWM6	PWM5	PWM4	PWM3	PWM2	PWM1	PWM0
Type	RO	RO	RO	RO	RO	RO	RO	RO	RW	RW	RW	RW	RW	RW	RW	RW
Reset	0	0	0	0	0	0	0	0	0	0	0	0	0	0	0	0

Bit/Field	Name	Type	Reset	Description
31:8	reserved	RO	0x0000.00	Software should not rely on the value of a reserved bit. To provide compatibility with future products, the value of a reserved bit should be preserved across a read-modify-write operation.
7	PWM7	RW	0	<p>M_nPWM_7 Fault Value</p> <p>Value Description</p> <p>0 The M_nPWM_7 output signal is driven Low during fault conditions if the FAULT7 bit in the PWMFAULT register is set.</p> <p>1 The M_nPWM_7 output signal is driven High during fault conditions if the FAULT7 bit in the PWMFAULT register is set.</p>
6	PWM6	RW	0	<p>M_nPWM_6 Fault Value</p> <p>Value Description</p> <p>0 The M_nPWM_6 output signal is driven Low during fault conditions if the FAULT6 bit in the PWMFAULT register is set.</p> <p>1 The M_nPWM_6 output signal is driven High during fault conditions if the FAULT6 bit in the PWMFAULT register is set.</p>
5	PWM5	RW	0	<p>M_nPWM_5 Fault Value</p> <p>Value Description</p> <p>0 The M_nPWM_5 output signal is driven Low during fault conditions if the FAULT5 bit in the PWMFAULT register is set.</p> <p>1 The M_nPWM_5 output signal is driven High during fault conditions if the FAULT5 bit in the PWMFAULT register is set.</p>

Bit/Field	Name	Type	Reset	Description
4	PWM4	RW	0	MnPWM4 Fault Value Value Description 0 The MnPWM4 output signal is driven Low during fault conditions if the FAULT4 bit in the PWMFAULT register is set. 1 The MnPWM4 output signal is driven High during fault conditions if the FAULT4 bit in the PWMFAULT register is set.
3	PWM3	RW	0	MnPWM3 Fault Value Value Description 0 The MnPWM3 output signal is driven Low during fault conditions if the FAULT3 bit in the PWMFAULT register is set. 1 The MnPWM3 output signal is driven High during fault conditions if the FAULT3 bit in the PWMFAULT register is set.
2	PWM2	RW	0	MnPWM2 Fault Value Value Description 0 The MnPWM2 output signal is driven Low during fault conditions if the FAULT2 bit in the PWMFAULT register is set. 1 The MnPWM2 output signal is driven High during fault conditions if the FAULT2 bit in the PWMFAULT register is set.
1	PWM1	RW	0	MnPWM1 Fault Value Value Description 0 The MnPWM1 output signal is driven Low during fault conditions if the FAULT1 bit in the PWMFAULT register is set. 1 The MnPWM1 output signal is driven High during fault conditions if the FAULT1 bit in the PWMFAULT register is set.
0	PWM0	RW	0	MnPWM0 Fault Value Value Description 0 The MnPWM0 output signal is driven Low during fault conditions if the FAULT0 bit in the PWMFAULT register is set. 1 The MnPWM0 output signal is driven High during fault conditions if the FAULT0 bit in the PWMFAULT register is set.

Register 11: PWM Enable Update (PWMENUPD), offset 0x028

This register specifies when updates to the PWM_nEN bit in the **PWMENABLE** register are performed. The PWM_nEN bit enables the pwmA' or pwmB' output to be passed to the microcontroller's pin. Updates can be immediate or locally or globally synchronized to the next synchronous update.

PWM Enable Update (PWMENUPD)

PWM0 base: 0x4002.8000
 Offset 0x028
 Type RW, reset 0x0000.0000

	31	30	29	28	27	26	25	24	23	22	21	20	19	18	17	16
	reserved															
Type	RO	RO	RO	RO	RO	RO	RO	RO	RO	RO	RO	RO	RO	RO	RO	RO
Reset	0	0	0	0	0	0	0	0	0	0	0	0	0	0	0	0
	15	14	13	12	11	10	9	8	7	6	5	4	3	2	1	0
	ENUPD7		ENUPD6		ENUPD5		ENUPD4		ENUPD3		ENUPD2		ENUPD1		ENUPD0	
Type	RW	RW	RW	RW	RW	RW	RW	RW	RW	RW	RW	RW	RW	RW	RW	RW
Reset	0	0	0	0	0	0	0	0	0	0	0	0	0	0	0	0

Bit/Field	Name	Type	Reset	Description
31:16	reserved	RO	0x00	Software should not rely on the value of a reserved bit. To provide compatibility with future products, the value of a reserved bit should be preserved across a read-modify-write operation.
15:14	ENUPD7	RW	0	<p>M_nPWM7 Enable Update Mode</p> <p>Value Description</p> <p>0x0 Immediate Writes to the $PWM7EN$ bit in the PWMENABLE register are used by the PWM generator immediately.</p> <p>0x1 Reserved</p> <p>0x2 Locally Synchronized Writes to the $PWM7EN$ bit in the PWMENABLE register are used by the PWM generator the next time the counter is 0.</p> <p>0x3 Globally Synchronized Writes to the $PWM7EN$ bit in the PWMENABLE register are used by the PWM generator the next time the counter is 0 after a synchronous update has been requested through the PWM Master Control (PWMCTL) register.</p>

Bit/Field	Name	Type	Reset	Description
13:12	ENUPD6	RW	0	<p>MnPWM6 Enable Update Mode</p> <p>Value Description</p> <p>0x0 Immediate Writes to the PWM6EN bit in the PWMENABLE register are used by the PWM generator immediately.</p> <p>0x1 Reserved</p> <p>0x2 Locally Synchronized Writes to the PWM6EN bit in the PWMENABLE register are used by the PWM generator the next time the counter is 0.</p> <p>0x3 Globally Synchronized Writes to the PWM6EN bit in the PWMENABLE register are used by the PWM generator the next time the counter is 0 after a synchronous update has been requested through the PWM Master Control (PWMCTL) register.</p>
11:10	ENUPD5	RW	0	<p>MnPWM5 Enable Update Mode</p> <p>Value Description</p> <p>0x0 Immediate Writes to the PWM5EN bit in the PWMENABLE register are used by the PWM generator immediately.</p> <p>0x1 Reserved</p> <p>0x2 Locally Synchronized Writes to the PWM5EN bit in the PWMENABLE register are used by the PWM generator the next time the counter is 0.</p> <p>0x3 Globally Synchronized Writes to the PWM5EN bit in the PWMENABLE register are used by the PWM generator the next time the counter is 0 after a synchronous update has been requested through the PWM Master Control (PWMCTL) register.</p>
9:8	ENUPD4	RW	0	<p>MnPWM4 Enable Update Mode</p> <p>Value Description</p> <p>0x0 Immediate Writes to the PWM4EN bit in the PWMENABLE register are used by the PWM generator immediately.</p> <p>0x1 Reserved</p> <p>0x2 Locally Synchronized Writes to the PWM4EN bit in the PWMENABLE register are used by the PWM generator the next time the counter is 0.</p> <p>0x3 Globally Synchronized Writes to the PWM4EN bit in the PWMENABLE register are used by the PWM generator the next time the counter is 0 after a synchronous update has been requested through the PWM Master Control (PWMCTL) register.</p>

Bit/Field	Name	Type	Reset	Description
7:6	ENUPD3	RW	0	<p>MnPWM3 Enable Update Mode</p> <p>Value Description</p> <p>0x0 Immediate Writes to the <code>PWM3EN</code> bit in the PWMENABLE register are used by the PWM generator immediately.</p> <p>0x1 Reserved</p> <p>0x2 Locally Synchronized Writes to the <code>PWM3EN</code> bit in the PWMENABLE register are used by the PWM generator the next time the counter is 0.</p> <p>0x3 Globally Synchronized Writes to the <code>PWM3EN</code> bit in the PWMENABLE register are used by the PWM generator the next time the counter is 0 after a synchronous update has been requested through the PWM Master Control (PWMCTL) register.</p>
5:4	ENUPD2	RW	0	<p>MnPWM2 Enable Update Mode</p> <p>Value Description</p> <p>0x0 Immediate Writes to the <code>PWM2EN</code> bit in the PWMENABLE register are used by the PWM generator immediately.</p> <p>0x1 Reserved</p> <p>0x2 Locally Synchronized Writes to the <code>PWM2EN</code> bit in the PWMENABLE register are used by the PWM generator the next time the counter is 0.</p> <p>0x3 Globally Synchronized Writes to the <code>PWM2EN</code> bit in the PWMENABLE register are used by the PWM generator the next time the counter is 0 after a synchronous update has been requested through the PWM Master Control (PWMCTL) register.</p>
3:2	ENUPD1	RW	0	<p>MnPWM1 Enable Update Mode</p> <p>Value Description</p> <p>0x0 Immediate Writes to the <code>PWM1EN</code> bit in the PWMENABLE register are used by the PWM generator immediately.</p> <p>0x1 Reserved</p> <p>0x2 Locally Synchronized Writes to the <code>PWM1EN</code> bit in the PWMENABLE register are used by the PWM generator the next time the counter is 0.</p> <p>0x3 Globally Synchronized Writes to the <code>PWM1EN</code> bit in the PWMENABLE register are used by the PWM generator the next time the counter is 0 after a synchronous update has been requested through the PWM Master Control (PWMCTL) register.</p>

Bit/Field	Name	Type	Reset	Description
1:0	ENUPD0	RW	0	MnPWM0 Enable Update Mode
				Value Description
				0x0 Immediate
				Writes to the <code>PWM0EN</code> bit in the <code>PWMENABLE</code> register are used by the PWM generator immediately.
				0x1 Reserved
				0x2 Locally Synchronized
				Writes to the <code>PWM0EN</code> bit in the <code>PWMENABLE</code> register are used by the PWM generator the next time the counter is 0.
				0x3 Globally Synchronized
				Writes to the <code>PWM0EN</code> bit in the <code>PWMENABLE</code> register are used by the PWM generator the next time the counter is 0 after a synchronous update has been requested through the PWM Master Control (<code>PWMCTL</code>) register.

Register 12: PWM0 Control (PWM0CTL), offset 0x040

Register 13: PWM1 Control (PWM1CTL), offset 0x080

Register 14: PWM2 Control (PWM2CTL), offset 0x0C0

Register 15: PWM3 Control (PWM3CTL), offset 0x100

These registers configure the PWM signal generation blocks (PWM0CTL controls the PWM generator 0 block, and so on). The Register Update mode, Debug mode, Counting mode, and Block Enable mode are all controlled via these registers. The blocks produce the PWM signals, which can be either two independent PWM signals (from the same counter), or a paired set of PWM signals with dead-band delays added.

The PWM0 block produces the $MnPWM0$ and $MnPWM1$ outputs, the PWM1 block produces the $MnPWM2$ and $MnPWM3$ outputs, the PWM2 block produces the $MnPWM4$ and $MnPWM5$ outputs, and the PWM3 block produces the $MnPWM6$ and $MnPWM7$ outputs.

PWMn Control (PWMnCTL)

PWM0 base: 0x4002.8000
 Offset 0x040
 Type RW, reset 0x0000.0000

	31	30	29	28	27	26	25	24	23	22	21	20	19	18	17	16
	reserved													LATCH	MINFLTPER	FLTSRC
Type	RO	RO	RO	RO	RO	RO	RO	RO	RO	RO	RO	RO	RO	RW	RW	RW
Reset	0	0	0	0	0	0	0	0	0	0	0	0	0	0	0	0
	15	14	13	12	11	10	9	8	7	6	5	4	3	2	1	0
	DBFALLUPD		DBRISEUPD		DBCTLUPD		GENBUPD		GENAUPD		CMPBUPD	CMPAUPD	LOADUPD	DEBUG	MODE	ENABLE
Type	RW	RW	RW	RW	RW	RW	RW	RW	RW	RW	RW	RW	RW	RW	RW	RW
Reset	0	0	0	0	0	0	0	0	0	0	0	0	0	0	0	0

Bit/Field	Name	Type	Reset	Description
31:19	reserved	RO	0x000	Software should not rely on the value of a reserved bit. To provide compatibility with future products, the value of a reserved bit should be preserved across a read-modify-write operation.
18	LATCH	RW	0	Latch Fault Input
				Value Description
			0	Fault Condition Not Latched A fault condition is in effect for as long as the generating source is asserting.
			1	Fault Condition Latched A fault condition is set as the result of the assertion of the faulting source and is held (latched) while the PWMISC INTFAULTn bit is set. Clearing the INTFAULTn bit clears the fault condition.
	Note:			When using an ADC digital comparator as a fault source, the LATCH and MINFLTPER bits in the PWMnCTL register should be set to 1 to ensure trigger assertions are captured.

Bit/Field	Name	Type	Reset	Description
17	MINFLTPER	RW	0	<p>Minimum Fault Period</p> <p>This bit specifies that the PWM generator enables a one-shot counter to provide a minimum fault condition period.</p> <p>The timer begins counting on the rising edge of the fault condition to extend the condition for a minimum duration of the count value. The timer ignores the state of the fault condition while counting.</p> <p>The minimum fault delay is in effect only when the MINFLTPER bit is set. If a detected fault is in the process of being extended when the MINFLTPER bit is cleared, the fault condition extension is aborted.</p> <p>The delay time is specified by the PWMnMINFLTPER register MFP field value. The effect of this is to pulse stretch the fault condition input.</p> <p>The delay value is defined by the PWM clock period. Because the fault input is not synchronized to the PWM clock, the period of the time is $PWMClock * (MFP \text{ value} + 1)$ or $PWMClock * (MFP \text{ value} + 2)$.</p> <p>The delay function makes sense only if the fault source is unlatched. A latched fault source makes the fault condition appear asserted until cleared by software and negates the utility of the extend feature. It applies to all fault condition sources as specified in the FLTSRC field.</p> <p>Value Description</p> <p>0 The FAULT input deassertion is unaffected.</p> <p>1 The PWMnMINFLTPER one-shot counter is active and extends the period of the fault condition to a minimum period.</p> <p>Note: When using an ADC digital comparator as a fault source, the LATCH and MINFLTPER bits in the PWMnCTL register should be set to 1 to ensure trigger assertions are captured.</p>
16	FLTSRC	RW	0	<p>Fault Condition Source</p> <p>Value Description</p> <p>0 The Fault condition is determined by the Fault0 input.</p> <p>1 The Fault condition is determined by the configuration of the PWMnFLTSRC0 and PWMnFLTSRC1 registers.</p>
15:14	DBFALLUPD	RW	0x0	<p>PWMnDBFALL Update Mode</p> <p>Value Description</p> <p>0x0 Immediate The PWMnDBFALL register value is immediately updated on a write.</p> <p>0x1 Reserved</p> <p>0x2 Locally Synchronized Updates to the register are reflected to the generator the next time the counter is 0.</p> <p>0x3 Globally Synchronized Updates to the register are delayed until the next time the counter is 0 after a synchronous update has been requested through the PWMCTL register.</p>

Bit/Field	Name	Type	Reset	Description
13:12	DBRISEUPD	RW	0x0	<p>PWMnDBRISE Update Mode</p> <p>Value Description</p> <p>0x0 Immediate The PWMnDBRISE register value is immediately updated on a write.</p> <p>0x1 Reserved</p> <p>0x2 Locally Synchronized Updates to the register are reflected to the generator the next time the counter is 0.</p> <p>0x3 Globally Synchronized Updates to the register are delayed until the next time the counter is 0 after a synchronous update has been requested through the PWMCTL register.</p>
11:10	DBCTLUPD	RW	0x0	<p>PWMnDBCTL Update Mode</p> <p>Value Description</p> <p>0x0 Immediate The PWMnDBCTL register value is immediately updated on a write.</p> <p>0x1 Reserved</p> <p>0x2 Locally Synchronized Updates to the register are reflected to the generator the next time the counter is 0.</p> <p>0x3 Globally Synchronized Updates to the register are delayed until the next time the counter is 0 after a synchronous update has been requested through the PWMCTL register.</p>
9:8	GENBUPD	RW	0x0	<p>PWMnGENB Update Mode</p> <p>Value Description</p> <p>0x0 Immediate The PWMnGENB register value is immediately updated on a write.</p> <p>0x1 Reserved</p> <p>0x2 Locally Synchronized Updates to the register are reflected to the generator the next time the counter is 0.</p> <p>0x3 Globally Synchronized Updates to the register are delayed until the next time the counter is 0 after a synchronous update has been requested through the PWMCTL register.</p>

Bit/Field	Name	Type	Reset	Description										
7:6	GENAUPD	RW	0x0	<p>PWMnGENA Update Mode</p> <table border="1"> <thead> <tr> <th>Value</th> <th>Description</th> </tr> </thead> <tbody> <tr> <td>0x0</td> <td>Immediate The PWMnGENA register value is immediately updated on a write.</td> </tr> <tr> <td>0x1</td> <td>Reserved</td> </tr> <tr> <td>0x2</td> <td>Locally Synchronized Updates to the register are reflected to the generator the next time the counter is 0.</td> </tr> <tr> <td>0x3</td> <td>Globally Synchronized Updates to the register are delayed until the next time the counter is 0 after a synchronous update has been requested through the PWMCTL register.</td> </tr> </tbody> </table>	Value	Description	0x0	Immediate The PWMnGENA register value is immediately updated on a write.	0x1	Reserved	0x2	Locally Synchronized Updates to the register are reflected to the generator the next time the counter is 0.	0x3	Globally Synchronized Updates to the register are delayed until the next time the counter is 0 after a synchronous update has been requested through the PWMCTL register.
Value	Description													
0x0	Immediate The PWMnGENA register value is immediately updated on a write.													
0x1	Reserved													
0x2	Locally Synchronized Updates to the register are reflected to the generator the next time the counter is 0.													
0x3	Globally Synchronized Updates to the register are delayed until the next time the counter is 0 after a synchronous update has been requested through the PWMCTL register.													
5	CMPBUPD	RW	0	<p>Comparator B Update Mode</p> <table border="1"> <thead> <tr> <th>Value</th> <th>Description</th> </tr> </thead> <tbody> <tr> <td>0</td> <td>Locally Synchronized Updates to the PWMnCMPB register are reflected to the generator the next time the counter is 0.</td> </tr> <tr> <td>1</td> <td>Globally Synchronized Updates to the register are delayed until the next time the counter is 0 after a synchronous update has been requested through the PWMCTL register.</td> </tr> </tbody> </table>	Value	Description	0	Locally Synchronized Updates to the PWMnCMPB register are reflected to the generator the next time the counter is 0.	1	Globally Synchronized Updates to the register are delayed until the next time the counter is 0 after a synchronous update has been requested through the PWMCTL register.				
Value	Description													
0	Locally Synchronized Updates to the PWMnCMPB register are reflected to the generator the next time the counter is 0.													
1	Globally Synchronized Updates to the register are delayed until the next time the counter is 0 after a synchronous update has been requested through the PWMCTL register.													
4	CMPAUPD	RW	0	<p>Comparator A Update Mode</p> <table border="1"> <thead> <tr> <th>Value</th> <th>Description</th> </tr> </thead> <tbody> <tr> <td>0</td> <td>Locally Synchronized Updates to the PWMnCMPA register are reflected to the generator the next time the counter is 0.</td> </tr> <tr> <td>1</td> <td>Globally Synchronized Updates to the register are delayed until the next time the counter is 0 after a synchronous update has been requested through the PWMCTL register.</td> </tr> </tbody> </table>	Value	Description	0	Locally Synchronized Updates to the PWMnCMPA register are reflected to the generator the next time the counter is 0.	1	Globally Synchronized Updates to the register are delayed until the next time the counter is 0 after a synchronous update has been requested through the PWMCTL register.				
Value	Description													
0	Locally Synchronized Updates to the PWMnCMPA register are reflected to the generator the next time the counter is 0.													
1	Globally Synchronized Updates to the register are delayed until the next time the counter is 0 after a synchronous update has been requested through the PWMCTL register.													
3	LOADUPD	RW	0	<p>Load Register Update Mode</p> <table border="1"> <thead> <tr> <th>Value</th> <th>Description</th> </tr> </thead> <tbody> <tr> <td>0</td> <td>Locally Synchronized Updates to the PWMnLOAD register are reflected to the generator the next time the counter is 0.</td> </tr> <tr> <td>1</td> <td>Globally Synchronized Updates to the register are delayed until the next time the counter is 0 after a synchronous update has been requested through the PWMCTL register.</td> </tr> </tbody> </table>	Value	Description	0	Locally Synchronized Updates to the PWMnLOAD register are reflected to the generator the next time the counter is 0.	1	Globally Synchronized Updates to the register are delayed until the next time the counter is 0 after a synchronous update has been requested through the PWMCTL register.				
Value	Description													
0	Locally Synchronized Updates to the PWMnLOAD register are reflected to the generator the next time the counter is 0.													
1	Globally Synchronized Updates to the register are delayed until the next time the counter is 0 after a synchronous update has been requested through the PWMCTL register.													

Bit/Field	Name	Type	Reset	Description
2	DEBUG	RW	0	Debug Mode Value Description 0 The counter stops running when it next reaches 0 and continues running again when no longer in Debug mode. 1 The counter always runs when in Debug mode.
1	MODE	RW	0	Counter Mode Value Description 0 The counter counts down from the load value to 0 and then wraps back to the load value (Count-Down mode). 1 The counter counts up from 0 to the load value, back down to 0, and then repeats (Count-Up/Down mode).
0	ENABLE	RW	0	PWM Block Enable Note: Disabling the PWM by clearing the <code>ENABLE</code> bit does not clear the <code>COUNT</code> field of the <code>PWMnCOUNT</code> register. Before re-enabling the PWM (<code>ENABLE = 0x1</code>), the <code>COUNT</code> field should be cleared by resetting the PWM registers through the <code>SRPWM</code> register in the System Control Module. Value Description 0 The entire PWM generation block is disabled and not clocked. 1 The PWM generation block is enabled and produces PWM signals.

Register 16: PWM0 Interrupt and Trigger Enable (PWM0INTEN), offset 0x044

Register 17: PWM1 Interrupt and Trigger Enable (PWM1INTEN), offset 0x084

Register 18: PWM2 Interrupt and Trigger Enable (PWM2INTEN), offset 0x0C4

Register 19: PWM3 Interrupt and Trigger Enable (PWM3INTEN), offset 0x104

These registers control the interrupt and ADC trigger generation capabilities of the PWM generators (**PWM0INTEN** controls the PWM generator 0 block, and so on). The events that can cause an interrupt, or an ADC trigger are:

- The counter being equal to the load register
- The counter being equal to zero
- The counter being equal to the **PWMnCMPA** register while counting up
- The counter being equal to the **PWMnCMPA** register while counting down
- The counter being equal to the **PWMnCMPB** register while counting up
- The counter being equal to the **PWMnCMPB** register while counting down

Any combination of these events can generate either an interrupt or an ADC trigger, though no determination can be made as to the actual event that caused an ADC trigger if more than one is specified. The **PWMnRIS** register provides information about which events have caused raw interrupts.

PWMn Interrupt and Trigger Enable (PWMnINTEN)

PWM0 base: 0x4002.8000
Offset 0x044
Type RW, reset 0x0000.0000

	31	30	29	28	27	26	25	24	23	22	21	20	19	18	17	16
	reserved															
Type	RO	RO	RO	RO	RO	RO	RO	RO	RO	RO	RO	RO	RO	RO	RO	RO
Reset	0	0	0	0	0	0	0	0	0	0	0	0	0	0	0	0
	15	14	13	12	11	10	9	8	7	6	5	4	3	2	1	0
	reserved		TRCMPBD	TRCMPBU	TRCMPAD	TRCMPAU	TRCNTLOAD	TRCNTZERO	reserved		INTCMPBD	INTCMPBU	INTCMPAD	INTCMPAU	INTCNTLOAD	INTCNTZERO
Type	RO	RO	RW	RW	RW	RW	RW	RW	RO	RO	RW	RW	RW	RW	RW	RW
Reset	0	0	0	0	0	0	0	0	0	0	0	0	0	0	0	0

Bit/Field	Name	Type	Reset	Description
31:14	reserved	RO	0	Software should not rely on the value of a reserved bit. To provide compatibility with future products, the value of a reserved bit should be preserved across a read-modify-write operation.
13	TRCMPBD	RW	0	Trigger for Counter= PWMnCMPB Down
	Value	Description		
	0	No ADC trigger is output.		
	1	An ADC trigger pulse is output when the counter matches the value in the PWMnCMPB register value while counting down.		

Bit/Field	Name	Type	Reset	Description
12	TRCMPBU	RW	0	<p>Trigger for Counter=PWMnCMPB Up</p> <p>Value Description</p> <p>0 No ADC trigger is output.</p> <p>1 An ADC trigger pulse is output when the counter matches the value in the PWMnCMPB register value while counting up.</p>
11	TRCMPAD	RW	0	<p>Trigger for Counter=PWMnCMPA Down</p> <p>Value Description</p> <p>0 No ADC trigger is output.</p> <p>1 An ADC trigger pulse is output when the counter matches the value in the PWMnCMPA register value while counting down.</p>
10	TRCMPAU	RW	0	<p>Trigger for Counter=PWMnCMPA Up</p> <p>Value Description</p> <p>0 No ADC trigger is output.</p> <p>1 An ADC trigger pulse is output when the counter matches the value in the PWMnCMPA register value while counting up.</p>
9	TRCNTLOAD	RW	0	<p>Trigger for Counter=PWMnLOAD</p> <p>Value Description</p> <p>0 No ADC trigger is output.</p> <p>1 An ADC trigger pulse is output when the counter matches the PWMnLOAD register.</p>
8	TRCNTZERO	RW	0	<p>Trigger for Counter=0</p> <p>Value Description</p> <p>0 No ADC trigger is output.</p> <p>1 An ADC trigger pulse is output when the counter is 0.</p>
7:6	reserved	RO	0x0	Software should not rely on the value of a reserved bit. To provide compatibility with future products, the value of a reserved bit should be preserved across a read-modify-write operation.
5	INTCMPBD	RW	0	<p>Interrupt for Counter=PWMnCMPB Down</p> <p>Value Description</p> <p>0 No interrupt.</p> <p>1 A raw interrupt occurs when the counter matches the value in the PWMnCMPB register value while counting down.</p>

Bit/Field	Name	Type	Reset	Description
4	INTCMPBU	RW	0	Interrupt for Counter= PWMnCMPB Up Value Description 0 No interrupt. 1 A raw interrupt occurs when the counter matches the value in the PWMnCMPB register value while counting up.
3	INTCMPAD	RW	0	Interrupt for Counter= PWMnCMPA Down Value Description 0 No interrupt. 1 A raw interrupt occurs when the counter matches the value in the PWMnCMPA register value while counting down.
2	INTCMPAU	RW	0	Interrupt for Counter= PWMnCMPA Up Value Description 0 No interrupt. 1 A raw interrupt occurs when the counter matches the value in the PWMnCMPA register value while counting up.
1	INTCNTLOAD	RW	0	Interrupt for Counter= PWMnLOAD Value Description 0 No interrupt. 1 A raw interrupt occurs when the counter matches the value in the PWMnLOAD register value.
0	INTCNTZERO	RW	0	Interrupt for Counter=0 Value Description 0 No interrupt. 1 A raw interrupt occurs when the counter is zero.

Register 20: PWM0 Raw Interrupt Status (PWM0RIS), offset 0x048

Register 21: PWM1 Raw Interrupt Status (PWM1RIS), offset 0x088

Register 22: PWM2 Raw Interrupt Status (PWM2RIS), offset 0x0C8

Register 23: PWM3 Raw Interrupt Status (PWM3RIS), offset 0x108

These registers provide the current set of interrupt sources that are asserted, regardless of whether they cause an interrupt to be asserted to the controller (**PWM0RIS** controls the PWM generator 0 block, and so on). If a bit is set, the event has occurred; if a bit is clear, the event has not occurred. Bits in this register are cleared by writing a 1 to the corresponding bit in the **PWMnISC** register.

PWMn Raw Interrupt Status (PWMnRIS)

PWM0 base: 0x4002.8000
 Offset 0x048
 Type RO, reset 0x0000.0000

	31	30	29	28	27	26	25	24	23	22	21	20	19	18	17	16	
	reserved																
Type	RO	RO	RO	RO	RO	RO	RO	RO	RO	RO	RO	RO	RO	RO	RO	RO	
Reset	0	0	0	0	0	0	0	0	0	0	0	0	0	0	0	0	
	15	14	13	12	11	10	9	8	7	6	5	4	3	2	1	0	
	reserved											INTCMPBD	INTCMPBU	INTCMPAD	INTCMPAU	INTCNTLOAD	INTCNTZERO
Type	RO	RO	RO	RO	RO	RO	RO	RO	RO	RO	RO	RO	RO	RO	RO	RO	
Reset	0	0	0	0	0	0	0	0	0	0	0	0	0	0	0	0	

Bit/Field	Name	Type	Reset	Description
31:6	reserved	RO	0	Software should not rely on the value of a reserved bit. To provide compatibility with future products, the value of a reserved bit should be preserved across a read-modify-write operation.
5	INTCMPBD	RO	0	Comparator B Down Interrupt Status Value Description 0 An interrupt has not occurred. 1 The counter has matched the value in the PWMnCMPB register while counting down. This bit is cleared by writing a 1 to the INTCMPBD bit in the PWMnISC register.
4	INTCMPBU	RO	0	Comparator B Up Interrupt Status Value Description 0 An interrupt has not occurred. 1 The counter has matched the value in the PWMnCMPB register while counting up. This bit is cleared by writing a 1 to the INTCMPBU bit in the PWMnISC register.

Bit/Field	Name	Type	Reset	Description
3	INTCMPAD	RO	0	<p>Comparator A Down Interrupt Status</p> <p>Value Description</p> <p>0 An interrupt has not occurred.</p> <p>1 The counter has matched the value in the PWMnCMPA register while counting down.</p> <p>This bit is cleared by writing a 1 to the INTCMPAD bit in the PWMnISC register.</p>
2	INTCMPAU	RO	0	<p>Comparator A Up Interrupt Status</p> <p>Value Description</p> <p>0 An interrupt has not occurred.</p> <p>1 The counter has matched the value in the PWMnCMPA register while counting up.</p> <p>This bit is cleared by writing a 1 to the INTCMPAU bit in the PWMnISC register.</p>
1	INTCNTLOAD	RO	0	<p>Counter=Load Interrupt Status</p> <p>Value Description</p> <p>0 An interrupt has not occurred.</p> <p>1 The counter has matched the value in the PWMnLOAD register.</p> <p>This bit is cleared by writing a 1 to the INTCNTLOAD bit in the PWMnISC register.</p>
0	INTCNTZERO	RO	0	<p>Counter=0 Interrupt Status</p> <p>Value Description</p> <p>0 An interrupt has not occurred.</p> <p>1 The counter has matched zero.</p> <p>This bit is cleared by writing a 1 to the INTCNTZERO bit in the PWMnISC register.</p>

Register 24: PWM0 Interrupt Status and Clear (PWM0ISC), offset 0x04C

Register 25: PWM1 Interrupt Status and Clear (PWM1ISC), offset 0x08C

Register 26: PWM2 Interrupt Status and Clear (PWM2ISC), offset 0x0CC

Register 27: PWM3 Interrupt Status and Clear (PWM3ISC), offset 0x10C

These registers provide the current set of interrupt sources that are asserted to the interrupt controller (**PWM0ISC** controls the PWM generator 0 block, and so on). A bit is set if the event has occurred and is enabled in the **PWMnINTEN** register; if a bit is clear, the event has not occurred or is not enabled. These are RW1C registers; writing a 1 to a bit position clears the corresponding interrupt reason.

Note: The interrupt status can only be cleared one PWM Clock cycle after the interrupt occurs. The larger the PWM Clock Divider (**PWMDIV**) value in **PWMCC** register, the longer the system delay is to clear the interrupt.

PWMn Interrupt Status and Clear (PWMnISC)

PWM0 base: 0x4002.8000
 Offset 0x04C
 Type RW1C, reset 0x0000.0000

	31	30	29	28	27	26	25	24	23	22	21	20	19	18	17	16	
	reserved																
Type	RO	RO	RO	RO	RO	RO	RO	RO	RO	RO	RO	RO	RO	RO	RO	RO	
Reset	0	0	0	0	0	0	0	0	0	0	0	0	0	0	0	0	
	15	14	13	12	11	10	9	8	7	6	5	4	3	2	1	0	
	reserved											INTCMPBD	INTCMPBU	INTCMPAD	INTCMPAU	INTCNTLOAD	INTCNTZERO
Type	RO	RO	RO	RO	RO	RO	RO	RO	RO	RO	RO	RW1C	RW1C	RW1C	RW1C	RW1C	
Reset	0	0	0	0	0	0	0	0	0	0	0	0	0	0	0	0	

Bit/Field	Name	Type	Reset	Description
31:6	reserved	RO	0	Software should not rely on the value of a reserved bit. To provide compatibility with future products, the value of a reserved bit should be preserved across a read-modify-write operation.
5	INTCMPBD	RW1C	0	Comparator B Down Interrupt Value Description 0 No interrupt has occurred or the interrupt is masked. 1 The INTCMPBD bits in the PWMnRIS and PWMnINTEN registers are set, providing an interrupt to the interrupt controller. This bit is cleared by writing a 1. Clearing this bit also clears the INTCMPBD bit in the PWMnRIS register.
4	INTCMPBU	RW1C	0	Comparator B Up Interrupt Value Description 0 No interrupt has occurred or the interrupt is masked. 1 The INTCMPBU bits in the PWMnRIS and PWMnINTEN registers are set, providing an interrupt to the interrupt controller. This bit is cleared by writing a 1. Clearing this bit also clears the INTCMPBU bit in the PWMnRIS register.

Bit/Field	Name	Type	Reset	Description
3	INTCMPAD	RW1C	0	<p>Comparator A Down Interrupt</p> <p>Value Description</p> <p>0 No interrupt has occurred or the interrupt is masked.</p> <p>1 The INTCMPAD bits in the PWMnRIS and PWMnINTEN registers are set, providing an interrupt to the interrupt controller.</p> <p>This bit is cleared by writing a 1. Clearing this bit also clears the INTCMPAD bit in the PWMnRIS register.</p>
2	INTCMPAU	RW1C	0	<p>Comparator A Up Interrupt</p> <p>Value Description</p> <p>0 No interrupt has occurred or the interrupt is masked.</p> <p>1 The INTCMPAU bits in the PWMnRIS and PWMnINTEN registers are set, providing an interrupt to the interrupt controller.</p> <p>This bit is cleared by writing a 1. Clearing this bit also clears the INTCMPAU bit in the PWMnRIS register.</p>
1	INTCNTLOAD	RW1C	0	<p>Counter=Load Interrupt</p> <p>Value Description</p> <p>0 No interrupt has occurred or the interrupt is masked.</p> <p>1 The INTCNTLOAD bits in the PWMnRIS and PWMnINTEN registers are set, providing an interrupt to the interrupt controller.</p> <p>This bit is cleared by writing a 1. Clearing this bit also clears the INTCNTLOAD bit in the PWMnRIS register.</p>
0	INTCNTZERO	RW1C	0	<p>Counter=0 Interrupt</p> <p>Value Description</p> <p>0 No interrupt has occurred or the interrupt is masked.</p> <p>1 The INTCNTZERO bits in the PWMnRIS and PWMnINTEN registers are set, providing an interrupt to the interrupt controller.</p> <p>This bit is cleared by writing a 1. Clearing this bit also clears the INTCNTZERO bit in the PWMnRIS register.</p>

Register 28: PWM0 Load (PWM0LOAD), offset 0x050

Register 29: PWM1 Load (PWM1LOAD), offset 0x090

Register 30: PWM2 Load (PWM2LOAD), offset 0x0D0

Register 31: PWM3 Load (PWM3LOAD), offset 0x110

These registers contain the load value for the PWM counter (**PWM0LOAD** controls the PWM generator 0 block, and so on). Based on the counter mode configured by the **MODE** bit in the **PWMnCTL** register, this value is either loaded into the counter after it reaches zero or is the limit of up-counting after which the counter decrements back to zero. When this value matches the counter, a pulse is output which can be configured to drive the generation of the **pwmA** and/or **pwmB** signal (via the **PWMnGENA/PWMnGENB** register) or drive an interruptor ADC trigger (via the **PWMnINTEN** register).

If the Load Value Update mode is locally synchronized (based on the **LOADUPD** field encoding in the **PWMnCTL** register), the 16-bit **LOAD** value is used the next time the counter reaches zero. If the update mode is globally synchronized, it is used the next time the counter reaches zero after a synchronous update has been requested through the **PWM Master Control (PWMCTL)** register (see page 1807). If this register is re-written before the actual update occurs, the previous value is never used and is lost.

PWMn Load (PWMnLOAD)

PWM0 base: 0x4002.8000
 Offset 0x050
 Type RW, reset 0x0000.0000

	31	30	29	28	27	26	25	24	23	22	21	20	19	18	17	16
	reserved															
Type	RO	RO	RO	RO	RO	RO	RO	RO	RO	RO	RO	RO	RO	RO	RO	RO
Reset	0	0	0	0	0	0	0	0	0	0	0	0	0	0	0	0
	15	14	13	12	11	10	9	8	7	6	5	4	3	2	1	0
	LOAD															
Type	RW	RW	RW	RW	RW	RW	RW	RW	RW	RW	RW	RW	RW	RW	RW	RW
Reset	0	0	0	0	0	0	0	0	0	0	0	0	0	0	0	0

Bit/Field	Name	Type	Reset	Description
31:16	reserved	RO	0x0000	Software should not rely on the value of a reserved bit. To provide compatibility with future products, the value of a reserved bit should be preserved across a read-modify-write operation.
15:0	LOAD	RW	0x0000	Counter Load Value The counter load value.

Register 32: PWM0 Counter (PWM0COUNT), offset 0x054

Register 33: PWM1 Counter (PWM1COUNT), offset 0x094

Register 34: PWM2 Counter (PWM2COUNT), offset 0x0D4

Register 35: PWM3 Counter (PWM3COUNT), offset 0x114

These registers contain the current value of the PWM counter (**PWM0COUNT** is the value of the PWM generator 0 block, and so on). When this value matches zero or the value in the **PWMnLOAD**, **PWMnCMPA**, or **PWMnCMPB** registers, a pulse is output which can be configured to drive the generation of a PWM signal or drive an interrupt or ADC trigger.

Note: Disabling the PWM by clearing the **ENABLE** bit does not clear the **COUNT** field of the **PWMnCOUNT** register. Before re-enabling the PWM (**ENABLE** = 0x1), the **COUNT** field should be cleared by resetting the PWM registers through the **SRPWM** register in the System Control Module.

PWMn Counter (PWMnCOUNT)

PWM0 base: 0x4002.8000

Offset 0x054

Type RO, reset 0x0000.0000

	31	30	29	28	27	26	25	24	23	22	21	20	19	18	17	16
	reserved															
Type	RO	RO	RO	RO	RO	RO	RO	RO	RO	RO	RO	RO	RO	RO	RO	RO
Reset	0	0	0	0	0	0	0	0	0	0	0	0	0	0	0	0
	15	14	13	12	11	10	9	8	7	6	5	4	3	2	1	0
	COUNT															
Type	RO	RO	RO	RO	RO	RO	RO	RO	RO	RO	RO	RO	RO	RO	RO	RO
Reset	0	0	0	0	0	0	0	0	0	0	0	0	0	0	0	0

Bit/Field	Name	Type	Reset	Description
31:16	reserved	RO	0x0000	Software should not rely on the value of a reserved bit. To provide compatibility with future products, the value of a reserved bit should be preserved across a read-modify-write operation.
15:0	COUNT	RO	0x0000	Counter Value The current value of the counter.

Register 36: PWM0 Compare A (PWM0CMPA), offset 0x058

Register 37: PWM1 Compare A (PWM1CMPA), offset 0x098

Register 38: PWM2 Compare A (PWM2CMPA), offset 0x0D8

Register 39: PWM3 Compare A (PWM3CMPA), offset 0x118

These registers contain a value to be compared against the counter (**PWM0CMPA** controls the PWM generator 0 block, and so on). When this value matches the counter, a pulse is output which can be configured to drive the generation of the pwmA and pwmB signals (via the **PWMnGENA** and **PWMnGENB** registers) or drive an interrupt or ADC trigger (via the **PWMnINTEN** register). If the value of this register is greater than the **PWMnLOAD** register (see page 1844), then no pulse is ever output.

If the comparator A update mode is locally synchronized (based on the **COMPAUPD** bit in the **PWMnCTL** register), the 16-bit **COMPA** value is used the next time the counter reaches zero. If the update mode is globally synchronized, it is used the next time the counter reaches zero after a synchronous update has been requested through the **PWM Master Control (PWMCTL)** register (see page 1807). If this register is rewritten before the actual update occurs, the previous value is never used and is lost.

PWMn Compare A (PWMnCMPA)

PWM0 base: 0x4002.8000
 Offset 0x058
 Type RW, reset 0x0000.0000

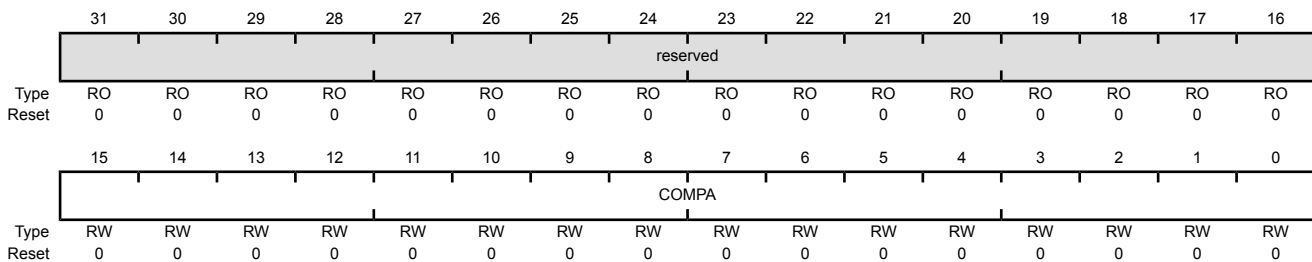

Bit/Field	Name	Type	Reset	Description
31:16	reserved	RO	0x00	Software should not rely on the value of a reserved bit. To provide compatibility with future products, the value of a reserved bit should be preserved across a read-modify-write operation.
15:0	COMPA	RW	0x00	Comparator A Value The value to be compared against the counter.

Register 40: PWM0 Compare B (PWM0CMPB), offset 0x05C**Register 41: PWM1 Compare B (PWM1CMPB), offset 0x09C****Register 42: PWM2 Compare B (PWM2CMPB), offset 0x0DC****Register 43: PWM3 Compare B (PWM3CMPB), offset 0x11C**

These registers contain a value to be compared against the counter (**PWM0CMPB** controls the PWM generator 0 block, and so on). When this value matches the counter, a pulse is output which can be configured to drive the generation of the pwmA and pwmB signals (via the **PWMnGENA** and **PWMnGENB** registers) or drive an interrupt or ADC trigger (via the **PWMnINTEN** register). If the value of this register is greater than the **PWMnLOAD** register, no pulse is ever output.

If the comparator B update mode is locally synchronized (based on the **COMPBUPD** bit in the **PWMnCTL** register), the 16-bit **COMPB** value is used the next time the counter reaches zero. If the update mode is globally synchronized, it is used the next time the counter reaches zero after a synchronous update has been requested through the **PWM Master Control (PWMCTL)** register (see page 1807). If this register is rewritten before the actual update occurs, the previous value is never used and is lost.

PWMn Compare B (PWMnCMPB)

PWM0 base: 0x4002.8000
Offset 0x05C
Type RW, reset 0x0000.0000

	31	30	29	28	27	26	25	24	23	22	21	20	19	18	17	16
	reserved															
Type	RO	RO	RO	RO	RO	RO	RO	RO	RO	RO	RO	RO	RO	RO	RO	RO
Reset	0	0	0	0	0	0	0	0	0	0	0	0	0	0	0	0
	15	14	13	12	11	10	9	8	7	6	5	4	3	2	1	0
	COMPB															
Type	RW	RW	RW	RW	RW	RW	RW	RW	RW	RW	RW	RW	RW	RW	RW	RW
Reset	0	0	0	0	0	0	0	0	0	0	0	0	0	0	0	0

Bit/Field	Name	Type	Reset	Description
31:16	reserved	RO	0x0000	Software should not rely on the value of a reserved bit. To provide compatibility with future products, the value of a reserved bit should be preserved across a read-modify-write operation.
15:0	COMPB	RW	0x0000	Comparator B Value The value to be compared against the counter.

Register 44: PWM0 Generator A Control (PWM0GENA), offset 0x060

Register 45: PWM1 Generator A Control (PWM1GENA), offset 0x0A0

Register 46: PWM2 Generator A Control (PWM2GENA), offset 0x0E0

Register 47: PWM3 Generator A Control (PWM3GENA), offset 0x120

These registers control the generation of the pwmA signal based on the load and zero output pulses from the counter, as well as the compare A and compare B pulses from the comparators (**PWM0GENA** controls the PWM generator 0 block, and so on). When the counter is running in Count-Down mode, only four of these events occur; when running in Count-Up/Down mode, all six occur. These events provide great flexibility in the positioning and duty cycle of the resulting PWM signal.

The **PWM0GENA** register controls generation of the pwm0A signal; **PWM1GENA**, the pwm1A signal; **PWM2GENA**, the pwm2A signal; and **PWM3GENA**, the pwm3A signal.

If a zero or load event coincides with a compare A or compare B event, the zero or load action is taken and the compare A or compare B action is ignored. If a compare A event coincides with a compare B event, the compare A action is taken and the compare B action is ignored.

If the Generator A update mode is immediate (based on the **GENAUPD** field encoding in the **PWMnCTL** register), the **ACTCMPBD**, **ACTCMPBU**, **ACTCMPAD**, **ACTCMPAU**, **ACTLOAD**, and **ACTZERO** values are used immediately. If the update mode is locally synchronized, these values are used the next time the counter reaches zero. If the update mode is globally synchronized, these values are used the next time the counter reaches zero after a synchronous update has been requested through the **PWM Master Control (PWMCTL)** register (see page 1807). If this register is rewritten before the actual update occurs, the previous value is never used and is lost.

PWMn Generator A Control (PWMnGENA)

PWM0 base: 0x4002.8000
Offset 0x060
Type RW, reset 0x0000.0000

	31	30	29	28	27	26	25	24	23	22	21	20	19	18	17	16
	reserved															
Type	RO	RO	RO	RO	RO	RO	RO	RO	RO	RO	RO	RO	RO	RO	RO	RO
Reset	0	0	0	0	0	0	0	0	0	0	0	0	0	0	0	0
	15	14	13	12	11	10	9	8	7	6	5	4	3	2	1	0
	reserved				ACTCMPBD		ACTCMPBU		ACTCMPAD		ACTCMPAU		ACTLOAD		ACTZERO	
Type	RO	RO	RO	RO	RW	RW	RW	RW	RW	RW	RW	RW	RW	RW	RW	RW
Reset	0	0	0	0	0	0	0	0	0	0	0	0	0	0	0	0

Bit/Field	Name	Type	Reset	Description
31:12	reserved	RO	0x0000.0	Software should not rely on the value of a reserved bit. To provide compatibility with future products, the value of a reserved bit should be preserved across a read-modify-write operation.

Bit/Field	Name	Type	Reset	Description
11:10	ACTCMPBD	RW	0x0	<p>Action for Comparator B Down</p> <p>This field specifies the action to be taken when the counter matches comparator B while counting down.</p> <p>Value Description</p> <p>0x0 Do nothing.</p> <p>0x1 Invert pwmA.</p> <p>0x2 Drive pwmA Low.</p> <p>0x3 Drive pwmA High.</p>
9:8	ACTCMPBU	RW	0x0	<p>Action for Comparator B Up</p> <p>This field specifies the action to be taken when the counter matches comparator B while counting up. This action can only occur when the MODE bit in the PWMnCTL register is set.</p> <p>Value Description</p> <p>0x0 Do nothing.</p> <p>0x1 Invert pwmA.</p> <p>0x2 Drive pwmA Low.</p> <p>0x3 Drive pwmA High.</p>
7:6	ACTCMPAD	RW	0x0	<p>Action for Comparator A Down</p> <p>This field specifies the action to be taken when the counter matches comparator A while counting down.</p> <p>Value Description</p> <p>0x0 Do nothing.</p> <p>0x1 Invert pwmA.</p> <p>0x2 Drive pwmA Low.</p> <p>0x3 Drive pwmA High.</p>
5:4	ACTCMPAU	RW	0x0	<p>Action for Comparator A Up</p> <p>This field specifies the action to be taken when the counter matches comparator A while counting up. This action can only occur when the MODE bit in the PWMnCTL register is set.</p> <p>Value Description</p> <p>0x0 Do nothing.</p> <p>0x1 Invert pwmA.</p> <p>0x2 Drive pwmA Low.</p> <p>0x3 Drive pwmA High.</p>

Bit/Field	Name	Type	Reset	Description
3:2	ACTLOAD	RW	0x0	Action for Counter=LOAD This field specifies the action to be taken when the counter matches the value in the PWMnLOAD register. Value Description 0x0 Do nothing. 0x1 Invert pwmA. 0x2 Drive pwmA Low. 0x3 Drive pwmA High.
1:0	ACTZERO	RW	0x0	Action for Counter=0 This field specifies the action to be taken when the counter is zero. Value Description 0x0 Do nothing. 0x1 Invert pwmA. 0x2 Drive pwmA Low. 0x3 Drive pwmA High.

Register 48: PWM0 Generator B Control (PWM0GENB), offset 0x064**Register 49: PWM1 Generator B Control (PWM1GENB), offset 0x0A4****Register 50: PWM2 Generator B Control (PWM2GENB), offset 0x0E4****Register 51: PWM3 Generator B Control (PWM3GENB), offset 0x124**

These registers control the generation of the pwmB signal based on the load and zero output pulses from the counter, as well as the compare A and compare B pulses from the comparators (**PWM0GENB** controls the PWM generator 0 block, and so on). When the counter is running in Count-Down mode, only four of these events occur; when running in Count-Up/Down mode, all six occur. These events provide great flexibility in the positioning and duty cycle of the resulting PWM signal.

The **PWM0GENB** register controls generation of the pwm0B signal; **PWM1GENB**, the pwm1B signal; **PWM2GENB**, the pwm2B signal; and **PWM3GENB**, the pwm3B signal.

If a zero or load event coincides with a compare A or compare B event, the zero or load action is taken and the compare A or compare B action is ignored. If a compare A event coincides with a compare B event, the compare B action is taken and the compare A action is ignored.

If the Generator B update mode is immediate (based on the **GENBUPD** field encoding in the **PWMnCTL** register), the **ACTCMPBD**, **ACTCMPBU**, **ACTCMPAD**, **ACTCMPAU**, **ACTLOAD**, and **ACTZERO** values are used immediately. If the update mode is locally synchronized, these values are used the next time the counter reaches zero. If the update mode is globally synchronized, these values are used the next time the counter reaches zero after a synchronous update has been requested through the **PWM Master Control (PWMCTL)** register (see page 1807). If this register is rewritten before the actual update occurs, the previous value is never used and is lost.

PWMn Generator B Control (PWMnGENB), offset 0x064

PWM0 base: 0x4002.8000
Offset 0x064
Type RW, reset 0x0000.0000

	31	30	29	28	27	26	25	24	23	22	21	20	19	18	17	16
	reserved															
Type	RO	RO	RO	RO	RO	RO	RO	RO	RO	RO	RO	RO	RO	RO	RO	RO
Reset	0	0	0	0	0	0	0	0	0	0	0	0	0	0	0	0
	15	14	13	12	11	10	9	8	7	6	5	4	3	2	1	0
	reserved				ACTCMPBD		ACTCMPBU		ACTCMPAD		ACTCMPAU		ACTLOAD		ACTZERO	
Type	RO	RO	RO	RO	RW	RW	RW	RW	RW	RW	RW	RW	RW	RW	RW	RW
Reset	0	0	0	0	0	0	0	0	0	0	0	0	0	0	0	0

Bit/Field	Name	Type	Reset	Description
31:12	reserved	RO	0x0000.0	Software should not rely on the value of a reserved bit. To provide compatibility with future products, the value of a reserved bit should be preserved across a read-modify-write operation.

Bit/Field	Name	Type	Reset	Description
11:10	ACTCMPBD	RW	0x0	<p>Action for Comparator B Down</p> <p>This field specifies the action to be taken when the counter matches comparator B while counting down.</p> <p>Value Description</p> <p>0x0 Do nothing.</p> <p>0x1 Invert pwmB.</p> <p>0x2 Drive pwmB Low.</p> <p>0x3 Drive pwmB High.</p>
9:8	ACTCMPBU	RW	0x0	<p>Action for Comparator B Up</p> <p>This field specifies the action to be taken when the counter matches comparator B while counting up. This action can only occur when the MODE bit in the PWMnCTL register is set.</p> <p>Value Description</p> <p>0x0 Do nothing.</p> <p>0x1 Invert pwmB.</p> <p>0x2 Drive pwmB Low.</p> <p>0x3 Drive pwmB High.</p>
7:6	ACTCMPAD	RW	0x0	<p>Action for Comparator A Down</p> <p>This field specifies the action to be taken when the counter matches comparator A while counting down.</p> <p>Value Description</p> <p>0x0 Do nothing.</p> <p>0x1 Invert pwmB.</p> <p>0x2 Drive pwmB Low.</p> <p>0x3 Drive pwmB High.</p>
5:4	ACTCMPAU	RW	0x0	<p>Action for Comparator A Up</p> <p>This field specifies the action to be taken when the counter matches comparator A while counting up. This action can only occur when the MODE bit in the PWMnCTL register is set.</p> <p>Value Description</p> <p>0x0 Do nothing.</p> <p>0x1 Invert pwmB.</p> <p>0x2 Drive pwmB Low.</p> <p>0x3 Drive pwmB High.</p>

Bit/Field	Name	Type	Reset	Description
3:2	ACTLOAD	RW	0x0	<p>Action for Counter=LOAD</p> <p>This field specifies the action to be taken when the counter matches the load value.</p> <p>Value Description</p> <p>0x0 Do nothing.</p> <p>0x1 Invert pwmB.</p> <p>0x2 Drive pwmB Low.</p> <p>0x3 Drive pwmB High.</p>
1:0	ACTZERO	RW	0x0	<p>Action for Counter=0</p> <p>This field specifies the action to be taken when the counter is 0.</p> <p>Value Description</p> <p>0x0 Do nothing.</p> <p>0x1 Invert pwmB.</p> <p>0x2 Drive pwmB Low.</p> <p>0x3 Drive pwmB High.</p>

Register 52: PWM0 Dead-Band Control (PWM0DBCTL), offset 0x068

Register 53: PWM1 Dead-Band Control (PWM1DBCTL), offset 0x0A8

Register 54: PWM2 Dead-Band Control (PWM2DBCTL), offset 0x0E8

Register 55: PWM3 Dead-Band Control (PWM3DBCTL), offset 0x128

The **PWMnDBCTL** register controls the dead-band generator, which produces the M_nP_{WMn} signals based on the *pwmA* and *pwmB* signals. When disabled, the *pwmA* signal passes through to the *pwmA'* signal and the *pwmB* signal passes through to the *pwmB'* signal. When dead-band control is enabled, the *pwmB* signal is ignored, the *pwmA'* signal is generated by delaying the rising edge(s) of the *pwmA* signal by the value in the **PWMnDBRISE** register (see page 1855), and the *pwmB'* signal is generated by inverting the *pwmA* signal and delaying the falling edge(s) of the *pwmA* signal by the value in the **PWMnDBFALL** register (see page 1856). The Output Control block outputs the *pwm0A'* signal on the M_nP_{WM0} signal and the *pwm0B'* signal on the M_nP_{WM1} signal. In a similar manner, M_nP_{WM2} and M_nP_{WM3} are produced from the *pwm1A'* and *pwm1B'* signals, M_nP_{WM4} and M_nP_{WM5} are produced from the *pwm2A'* and *pwm2B'* signals, and M_nP_{WM6} and M_nP_{WM7} are produced from the *pwm3A'* and *pwm3B'* signals.

If the Dead-Band Control mode is immediate (based on the **DBCTLUPD** field encoding in the **PWMnCTL** register), the **ENABLE** bit value is used immediately. If the update mode is locally synchronized, this value is used the next time the counter reaches zero. If the update mode is globally synchronized, this value is used the next time the counter reaches zero after a synchronous update has been requested through the **PWM Master Control (PWMCTL)** register (see page 1807). If this register is rewritten before the actual update occurs, the previous value is never used and is lost.

PWMn Dead-Band Control (PWMnDBCTL)

PWM0 base: 0x4002.8000
 Offset 0x068
 Type RW, reset 0x0000.0000

	31	30	29	28	27	26	25	24	23	22	21	20	19	18	17	16
	reserved															
Type	RO	RO	RO	RO	RO	RO	RO	RO	RO	RO	RO	RO	RO	RO	RO	RO
Reset	0	0	0	0	0	0	0	0	0	0	0	0	0	0	0	0
	15	14	13	12	11	10	9	8	7	6	5	4	3	2	1	0
	reserved															ENABLE
Type	RO	RO	RO	RO	RO	RO	RO	RO	RO	RO	RO	RO	RO	RO	RO	RW
Reset	0	0	0	0	0	0	0	0	0	0	0	0	0	0	0	0

Bit/Field	Name	Type	Reset	Description
31:1	reserved	RO	0x0000.000	Software should not rely on the value of a reserved bit. To provide compatibility with future products, the value of a reserved bit should be preserved across a read-modify-write operation.
0	ENABLE	RW	0	Dead-Band Generator Enable

Value	Description
0	The <i>pwmA</i> and <i>pwmB</i> signals pass through to the <i>pwmA'</i> and <i>pwmB'</i> signals unmodified.
1	The dead-band generator modifies the <i>pwmA</i> signal by inserting dead bands into the <i>pwmA'</i> and <i>pwmB'</i> signals.

Register 56: PWM0 Dead-Band Rising-Edge Delay (PWM0DBRISE), offset 0x06C

Register 57: PWM1 Dead-Band Rising-Edge Delay (PWM1DBRISE), offset 0x0AC

Register 58: PWM2 Dead-Band Rising-Edge Delay (PWM2DBRISE), offset 0x0EC

Register 59: PWM3 Dead-Band Rising-Edge Delay (PWM3DBRISE), offset 0x12C

The **PWMnDBRISE** register contains the number of clock cycles to delay the rising edge of the pwmA signal when generating the pwmA' signal. If the dead-band generator is disabled through the **PWMnDBCTL** register, this register is ignored. If the value of this register is larger than the width of a High pulse on the pwmA signal, the rising-edge delay consumes the entire High time of the signal, resulting in no High time on the output. Care must be taken to ensure that the pwmA High time always exceeds the rising-edge delay.

If the Dead-Band Rising-Edge Delay mode is immediate (based on the **DBRISEUPD** field encoding in the **PWMnCTL** register), the 12-bit **RISEDELAY** value is used immediately. If the update mode is locally synchronized, this value is used the next time the counter reaches zero. If the update mode is globally synchronized, this value is used the next time the counter reaches zero after a synchronous update has been requested through the **PWM Master Control (PWMCTL)** register (see page 1807). If this register is rewritten before the actual update occurs, the previous value is never used and is lost.

PWMn Dead-Band Rising-Edge Delay (PWMnDBRISE)

PWM0 base: 0x4002.8000
Offset 0x06C
Type RW, reset 0x0000.0000

	31	30	29	28	27	26	25	24	23	22	21	20	19	18	17	16
	reserved															
Type	RO	RO	RO	RO	RO	RO	RO	RO	RO	RO	RO	RO	RO	RO	RO	RO
Reset	0	0	0	0	0	0	0	0	0	0	0	0	0	0	0	0
	15	14	13	12	11	10	9	8	7	6	5	4	3	2	1	0
	reserved				RISEDELAY											
Type	RO	RO	RO	RO	RW	RW	RW	RW	RW	RW	RW	RW	RW	RW	RW	RW
Reset	0	0	0	0	0	0	0	0	0	0	0	0	0	0	0	0

Bit/Field	Name	Type	Reset	Description
31:12	reserved	RO	0x0000.0	Software should not rely on the value of a reserved bit. To provide compatibility with future products, the value of a reserved bit should be preserved across a read-modify-write operation.
11:0	RISEDELAY	RW	0x000	Dead-Band Rise Delay The number of clock cycles to delay the rising edge of pwmA' after the rising edge of pwmA.

Register 60: PWM0 Dead-Band Falling-Edge-Delay (PWM0DBFALL), offset 0x070

Register 61: PWM1 Dead-Band Falling-Edge-Delay (PWM1DBFALL), offset 0x0B0

Register 62: PWM2 Dead-Band Falling-Edge-Delay (PWM2DBFALL), offset 0x0F0

Register 63: PWM3 Dead-Band Falling-Edge-Delay (PWM3DBFALL), offset 0x130

The **PWMnDBFALL** register contains the number of clock cycles to delay the rising edge of the pwmB' signal from the falling edge of the pwmA signal. If the dead-band generator is disabled through the **PWMnDBCTL** register, this register is ignored. If the value of this register is larger than the width of a Low pulse on the pwmA signal, the falling-edge delay consumes the entire Low time of the signal, resulting in no Low time on the output. Care must be taken to ensure that the pwmA Low time always exceeds the falling-edge delay.

If the Dead-Band Falling-Edge-Delay mode is immediate (based on the **DBFALLUP** field encoding in the **PWMnCTL** register), the 12-bit **FALLDELAY** value is used immediately. If the update mode is locally synchronized, this value is used the next time the counter reaches zero. If the update mode is globally synchronized, this value is used the next time the counter reaches zero after a synchronous update has been requested through the **PWM Master Control (PWMCTL)** register (see page 1807). If this register is rewritten before the actual update occurs, the previous value is never used and is lost.

PWMn Dead-Band Falling-Edge-Delay (PWMnDBFALL)

PWM0 base: 0x4002.8000
 Offset 0x070
 Type RW, reset 0x0000.0000

	31	30	29	28	27	26	25	24	23	22	21	20	19	18	17	16
	reserved															
Type	RO	RO	RO	RO	RO	RO	RO	RO	RO	RO	RO	RO	RO	RO	RO	RO
Reset	0	0	0	0	0	0	0	0	0	0	0	0	0	0	0	0
	15	14	13	12	11	10	9	8	7	6	5	4	3	2	1	0
	reserved				FALLDELAY											
Type	RO	RO	RO	RO	RW	RW	RW	RW	RW	RW	RW	RW	RW	RW	RW	RW
Reset	0	0	0	0	0	0	0	0	0	0	0	0	0	0	0	0

Bit/Field	Name	Type	Reset	Description
31:12	reserved	RO	0x0000.0	Software should not rely on the value of a reserved bit. To provide compatibility with future products, the value of a reserved bit should be preserved across a read-modify-write operation.
11:0	FALLDELAY	RW	0x000	Dead-Band Fall Delay The number of clock cycles to delay the falling edge of pwmB' from the rising edge of pwmA.

Register 64: PWM0 Fault Source 0 (PWM0FLTSRC0), offset 0x074**Register 65: PWM1 Fault Source 0 (PWM1FLTSRC0), offset 0x0B4****Register 66: PWM2 Fault Source 0 (PWM2FLTSRC0), offset 0x0F4****Register 67: PWM3 Fault Source 0 (PWM3FLTSRC0), offset 0x134**

This register specifies which fault pin inputs are used to generate a fault condition. Each bit in the following register indicates whether the corresponding fault pin is included in the fault condition. All enabled fault pins are ORed together to form the **PWMnFLTSRC0** portion of the fault condition. The **PWMnFLTSRC0** fault condition is then ORed with the **PWMnFLTSRC1** fault condition to generate the final fault condition for the PWM generator.

If the **FLTSRC** bit in the **PWMnCTL** register (see page 1832) is clear, only the **Fault0** signal affects the fault condition generated. Otherwise, sources defined in **PWMnFLTSRC0** and **PWMnFLTSRC1** affect the fault condition generated.

PWMn Fault Source 0 (PWMnFLTSRC0)

PWM0 base: 0x4002.8000
Offset 0x074
Type RW, reset 0x0000.0000

	31	30	29	28	27	26	25	24	23	22	21	20	19	18	17	16	
	reserved																
Type	RO	RO	RO	RO	RO	RO	RO	RO	RO	RO	RO	RO	RO	RO	RO	RO	
Reset	0	0	0	0	0	0	0	0	0	0	0	0	0	0	0	0	
	15	14	13	12	11	10	9	8	7	6	5	4	3	2	1	0	
	reserved												FAULT3	FAULT2	FAULT1	FAULT0	
Type	RO	RO	RO	RO	RO	RO	RO	RO	RO	RO	RO	RO	RO	RW	RW	RW	RW
Reset	0	0	0	0	0	0	0	0	0	0	0	0	0	0	0	0	0

Bit/Field	Name	Type	Reset	Description
31:4	reserved	RO	0	Software should not rely on the value of a reserved bit. To provide compatibility with future products, the value of a reserved bit should be preserved across a read-modify-write operation.
3	FAULT3	RW	0	Fault3 Input
				Value Description
			0	The Fault3 signal is suppressed and cannot generate a fault condition.
			1	The Fault3 signal value is ORed with all other fault condition generation inputs (Faultn signals and digital comparators).

Note: The **FLTSRC** bit in the **PWMnCTL** register must be set for this bit to affect fault condition generation.

Bit/Field	Name	Type	Reset	Description
2	FAULT2	RW	0	<p>Fault2 Input</p> <p>Value Description</p> <p>0 The Fault2 signal is suppressed and cannot generate a fault condition.</p> <p>1 The Fault2 signal value is ORed with all other fault condition generation inputs (Faultn signals and digital comparators).</p> <p>Note: The FLTSRC bit in the PWMnCTL register must be set for this bit to affect fault condition generation.</p>
1	FAULT1	RW	0	<p>Fault1 Input</p> <p>Value Description</p> <p>0 The Fault1 signal is suppressed and cannot generate a fault condition.</p> <p>1 The Fault1 signal value is ORed with all other fault condition generation inputs (Faultn signals and digital comparators).</p> <p>Note: The FLTSRC bit in the PWMnCTL register must be set for this bit to affect fault condition generation.</p>
0	FAULT0	RW	0	<p>Fault0 Input</p> <p>Value Description</p> <p>0 The Fault0 signal is suppressed and cannot generate a fault condition.</p> <p>1 The Fault0 signal value is ORed with all other fault condition generation inputs (Faultn signals and digital comparators).</p> <p>Note: The FLTSRC bit in the PWMnCTL register must be set for this bit to affect fault condition generation.</p>

Register 68: PWM0 Fault Source 1 (PWM0FLTSRC1), offset 0x078**Register 69: PWM1 Fault Source 1 (PWM1FLTSRC1), offset 0x0B8****Register 70: PWM2 Fault Source 1 (PWM2FLTSRC1), offset 0x0F8****Register 71: PWM3 Fault Source 1 (PWM3FLTSRC1), offset 0x138**

This register specifies which digital comparator triggers from the ADC are used to generate a fault condition. Each bit in the following register indicates whether the corresponding digital comparator trigger is included in the fault condition. All enabled digital comparator triggers are ORed together to form the **PWMnFLTSRC1** portion of the fault condition. The **PWMnFLTSRC1** fault condition is then ORed with the **PWMnFLTSRC0** fault condition to generate the final fault condition for the PWM generator.

If the **FLTSRC** bit in the **PWMnCTL** register (see page 1832) is clear, only the PWM_{Fault0} pin affects the fault condition generated. Otherwise, sources defined in **PWMnFLTSRC0** and **PWMnFLTSRC1** affect the fault condition generated.

PWMn Fault Source 1 (PWMnFLTSRC1)

PWM0 base: 0x4002.8000

Offset 0x078

Type RW, reset 0x0000.0000

	31	30	29	28	27	26	25	24	23	22	21	20	19	18	17	16
	reserved															
Type	RO	RO	RO	RO	RO	RO	RO	RO	RO	RO	RO	RO	RO	RO	RO	RO
Reset	0	0	0	0	0	0	0	0	0	0	0	0	0	0	0	0
	15	14	13	12	11	10	9	8	7	6	5	4	3	2	1	0
	reserved								DCMP7	DCMP6	DCMP5	DCMP4	DCMP3	DCMP2	DCMP1	DCMP0
Type	RO	RO	RO	RO	RO	RO	RO	RO	RW	RW	RW	RW	RW	RW	RW	RW
Reset	0	0	0	0	0	0	0	0	0	0	0	0	0	0	0	0

Bit/Field	Name	Type	Reset	Description
31:8	reserved	RO	0x0000.00	Software should not rely on the value of a reserved bit. To provide compatibility with future products, the value of a reserved bit should be preserved across a read-modify-write operation.
7	DCMP7	RW	0	Digital Comparator 7
				Value Description
			0	The trigger from digital comparator 7 is suppressed and cannot generate a fault condition.
			1	The trigger from digital comparator 7 is ORed with all other fault condition generation inputs (Faultn signals and digital comparators).

Note: The **FLTSRC** bit in the **PWMnCTL** register must be set for this bit to affect fault condition generation.

Bit/Field	Name	Type	Reset	Description
6	DCMP6	RW	0	<p>Digital Comparator 6</p> <p>Value Description</p> <p>0 The trigger from digital comparator 6 is suppressed and cannot generate a fault condition.</p> <p>1 The trigger from digital comparator 6 is ORed with all other fault condition generation inputs (Faultn signals and digital comparators).</p> <p>Note: The FLTSRC bit in the PWMnCTL register must be set for this bit to affect fault condition generation.</p>
5	DCMP5	RW	0	<p>Digital Comparator 5</p> <p>Value Description</p> <p>0 The trigger from digital comparator 5 is suppressed and cannot generate a fault condition.</p> <p>1 The trigger from digital comparator 5 is ORed with all other fault condition generation inputs (Faultn signals and digital comparators).</p> <p>Note: The FLTSRC bit in the PWMnCTL register must be set for this bit to affect fault condition generation.</p>
4	DCMP4	RW	0	<p>Digital Comparator 4</p> <p>Value Description</p> <p>0 The trigger from digital comparator 4 is suppressed and cannot generate a fault condition.</p> <p>1 The trigger from digital comparator 4 is ORed with all other fault condition generation inputs (Faultn signals and digital comparators).</p> <p>Note: The FLTSRC bit in the PWMnCTL register must be set for this bit to affect fault condition generation.</p>
3	DCMP3	RW	0	<p>Digital Comparator 3</p> <p>Value Description</p> <p>0 The trigger from digital comparator 3 is suppressed and cannot generate a fault condition.</p> <p>1 The trigger from digital comparator 3 is ORed with all other fault condition generation inputs (Faultn signals and digital comparators).</p> <p>Note: The FLTSRC bit in the PWMnCTL register must be set for this bit to affect fault condition generation.</p>

Bit/Field	Name	Type	Reset	Description
2	DCMP2	RW	0	<p>Digital Comparator 2</p> <p>Value Description</p> <p>0 The trigger from digital comparator 2 is suppressed and cannot generate a fault condition.</p> <p>1 The trigger from digital comparator 2 is ORed with all other fault condition generation inputs (Faultn signals and digital comparators).</p> <p>Note: The FLTSRC bit in the PWMnCTL register must be set for this bit to affect fault condition generation.</p>
1	DCMP1	RW	0	<p>Digital Comparator 1</p> <p>Value Description</p> <p>0 The trigger from digital comparator 1 is suppressed and cannot generate a fault condition.</p> <p>1 The trigger from digital comparator 1 is ORed with all other fault condition generation inputs (Faultn signals and digital comparators).</p> <p>Note: The FLTSRC bit in the PWMnCTL register must be set for this bit to affect fault condition generation.</p>
0	DCMP0	RW	0	<p>Digital Comparator 0</p> <p>Value Description</p> <p>0 The trigger from digital comparator 0 is suppressed and cannot generate a fault condition.</p> <p>1 The trigger from digital comparator 0 is ORed with all other fault condition generation inputs (Faultn signals and digital comparators).</p> <p>Note: The FLTSRC bit in the PWMnCTL register must be set for this bit to affect fault condition generation.</p>

Register 72: PWM0 Minimum Fault Period (PWM0MINFLTPER), offset 0x07C

Register 73: PWM1 Minimum Fault Period (PWM1MINFLTPER), offset 0x0BC

Register 74: PWM2 Minimum Fault Period (PWM2MINFLTPER), offset 0x0FC

Register 75: PWM3 Minimum Fault Period (PWM3MINFLTPER), offset 0x13C

If the `MINFLTPER` bit in the `PWMnCTL` register is set, this register specifies the 16-bit time-extension value to be used in extending the fault condition. The value is loaded into a 16-bit down counter, and the counter value is used to extend the fault condition. The fault condition is released in the clock immediately after the counter value reaches 0. The fault condition is asynchronous to the PWM clock; and the delay value is the product of the PWM clock period and the (MFP field value + 1) or (MFP field value + 2) depending on when the fault condition asserts with respect to the PWM clock. The counter decrements at the PWM clock rate, without pause or condition.

PWMn Minimum Fault Period (PWMnMINFLTPER)

PWM0 base: 0x4002.8000
 Offset 0x07C
 Type RW, reset 0x0000.0000

	31	30	29	28	27	26	25	24	23	22	21	20	19	18	17	16
	reserved															
Type	RO	RO	RO	RO	RO	RO	RO	RO	RO	RO	RO	RO	RO	RO	RO	RO
Reset	0	0	0	0	0	0	0	0	0	0	0	0	0	0	0	0
	15	14	13	12	11	10	9	8	7	6	5	4	3	2	1	0
	MFP															
Type	RW	RW	RW	RW	RW	RW	RW	RW	RW	RW	RW	RW	RW	RW	RW	RW
Reset	0	0	0	0	0	0	0	0	0	0	0	0	0	0	0	0

Bit/Field	Name	Type	Reset	Description
31:16	reserved	RO	0x0000	Software should not rely on the value of a reserved bit. To provide compatibility with future products, the value of a reserved bit should be preserved across a read-modify-write operation.
15:0	MFP	RW	0x0000	Minimum Fault Period The number of PWM clocks by which a fault condition is extended when the delay is enabled by <code>PWMnCTL</code> <code>MINFLTPER</code> .

Register 76: PWM0 Fault Pin Logic Sense (PWM0FLTSEN), offset 0x800

Register 77: PWM1 Fault Pin Logic Sense (PWM1FLTSEN), offset 0x880

Register 78: PWM2 Fault Pin Logic Sense (PWM2FLTSEN), offset 0x900

Register 79: PWM3 Fault Pin Logic Sense (PWM3FLTSEN), offset 0x980

This register defines the PWM fault pin logic sense.

PWMn Fault Pin Logic Sense (PWMnFLTSEN)

PWM0 base: 0x4002.8000

Offset 0x800

Type RW, reset 0x0000.0000

	31	30	29	28	27	26	25	24	23	22	21	20	19	18	17	16
	reserved															
Type	RO	RO	RO	RO	RO	RO	RO	RO	RO	RO	RO	RO	RO	RO	RO	RO
Reset	0	0	0	0	0	0	0	0	0	0	0	0	0	0	0	0
	15	14	13	12	11	10	9	8	7	6	5	4	3	2	1	0
	reserved												FAULT3	FAULT2	FAULT1	FAULT0
Type	RO	RO	RO	RO	RO	RO	RO	RO	RO	RO	RO	RO	RW	RW	RW	RW
Reset	0	0	0	0	0	0	0	0	0	0	0	0	0	0	0	0

Bit/Field	Name	Type	Reset	Description
31:4	reserved	RO	0x0000.000	Software should not rely on the value of a reserved bit. To provide compatibility with future products, the value of a reserved bit should be preserved across a read-modify-write operation.
3	FAULT3	RW	0	Fault3 Sense Value Description 0 An error is indicated if the <code>Fault3</code> signal is High. 1 An error is indicated if the <code>Fault3</code> signal is Low.
2	FAULT2	RW	0	Fault2 Sense Value Description 0 An error is indicated if the <code>Fault2</code> signal is High. 1 An error is indicated if the <code>Fault2</code> signal is Low.
1	FAULT1	RW	0	Fault1 Sense Value Description 0 An error is indicated if the <code>Fault1</code> signal is High. 1 An error is indicated if the <code>Fault1</code> signal is Low.
0	FAULT0	RW	0	Fault0 Sense Value Description 0 An error is indicated if the <code>Fault0</code> signal is High. 1 An error is indicated if the <code>Fault0</code> signal is Low.

Register 80: PWM0 Fault Status 0 (PWM0FLTSTAT0), offset 0x804

Register 81: PWM1 Fault Status 0 (PWM1FLTSTAT0), offset 0x884

Register 82: PWM2 Fault Status 0 (PWM2FLTSTAT0), offset 0x904

Register 83: PWM3 Fault Status 0 (PWM3FLTSTAT0), offset 0x984

Along with the **PWMnFLTSTAT1** register, this register provides status regarding the fault condition inputs.

If the **LATCH** bit in the **PWMnCTL** register is clear, the contents of the **PWMnFLTSTAT0** register are read-only (RO) and provide the current state of the **MnFAULTn** inputs.

If the **LATCH** bit in the **PWMnCTL** register is set, the contents of the **PWMnFLTSTAT0** register are read / write 1 to clear (RW1C) and provide a latched version of the **MnFAULTn** inputs. In this mode, the register bits are cleared by writing a 1 to a set bit. The **MnFAULTn** inputs are recorded after their sense is adjusted in the generator.

The contents of this register can only be written if the fault source extensions are enabled (the **FLTSRC** bit in the **PWMnCTL** register is set).

Note: The fault status registers, **PWMnFLTSTAT0** and **PWMnFLTSTAT1**, reflect the status of all fault sources, regardless of what fault sources are enabled for that particular generator.

PWMn Fault Status 0 (PWMnFLTSTAT0)

PWM0 base: 0x4002.8000
 Offset 0x804
 Type -, reset 0x0000.0000

	31	30	29	28	27	26	25	24	23	22	21	20	19	18	17	16
	reserved															
Type	RO	RO	RO	RO	RO	RO	RO	RO	RO	RO	RO	RO	RO	RO	RO	RO
Reset	0	0	0	0	0	0	0	0	0	0	0	0	0	0	0	0
	15	14	13	12	11	10	9	8	7	6	5	4	3	2	1	0
	reserved												FAULT3	FAULT2	FAULT1	FAULT0
Type	RO	RO	RO	RO	RO	RO	RO	RO	RO	RO	RO	RO	-	-	-	-
Reset	0	0	0	0	0	0	0	0	0	0	0	0	0	0	0	0

Bit/Field	Name	Type	Reset	Description
31:4	reserved	RO	0	Software should not rely on the value of a reserved bit. To provide compatibility with future products, the value of a reserved bit should be preserved across a read-modify-write operation.
3	FAULT3	-	0	Fault Input 3 If the PWMnCTL register LATCH bit is clear, this bit is RO and represents the current state of the MnFAULT3 input signal after the logic sense adjustment. If the PWMnCTL register LATCH bit is set, this bit is RW1C and represents a sticky version of the MnFAULT3 input signal after the logic sense adjustment.
				<ul style="list-style-type: none"> ■ If FAULT3 is set, the input transitioned to the active state previously. ■ If FAULT3 is clear, the input has not transitioned to the active state since the last time it was cleared. ■ The FAULT3 bit is cleared by writing it with the value 1.

Bit/Field	Name	Type	Reset	Description
2	FAULT2	-	0	<p>Fault Input 2</p> <p>If the PWMnCTL register LATCH bit is clear, this bit is RO and represents the current state of the MnFAULT2 input signal after the logic sense adjustment.</p> <p>If the PWMnCTL register LATCH bit is set, this bit is RW1C and represents a sticky version of the MnFAULT2 input signal after the logic sense adjustment.</p> <ul style="list-style-type: none"> ■ If FAULT2 is set, the input transitioned to the active state previously. ■ If FAULT2 is clear, the input has not transitioned to the active state since the last time it was cleared. ■ The FAULT2 bit is cleared by writing it with the value 1.
1	FAULT1	-	0	<p>Fault Input 1</p> <p>If the PWMnCTL register LATCH bit is clear, this bit is RO and represents the current state of the MnFAULT1 input signal after the logic sense adjustment.</p> <p>If the PWMnCTL register LATCH bit is set, this bit is RW1C and represents a sticky version of the MnFAULT1 input signal after the logic sense adjustment.</p> <ul style="list-style-type: none"> ■ If FAULT1 is set, the input transitioned to the active state previously. ■ If FAULT1 is clear, the input has not transitioned to the active state since the last time it was cleared. ■ The FAULT1 bit is cleared by writing it with the value 1.
0	FAULT0	-	0	<p>Fault Input 0</p> <p>If the PWMnCTL register LATCH bit is clear, this bit is RO and represents the current state of the input signal after the logic sense adjustment.</p> <p>If the PWMnCTL register LATCH bit is set, this bit is RW1C and represents a sticky version of the input signal after the logic sense adjustment.</p> <ul style="list-style-type: none"> ■ If FAULT0 is set, the input transitioned to the active state previously. ■ If FAULT0 is clear, the input has not transitioned to the active state since the last time it was cleared. ■ The FAULT0 bit is cleared by writing it with the value 1.

Register 84: PWM0 Fault Status 1 (PWM0FLTSTAT1), offset 0x808

Register 85: PWM1 Fault Status 1 (PWM1FLTSTAT1), offset 0x888

Register 86: PWM2 Fault Status 1 (PWM2FLTSTAT1), offset 0x908

Register 87: PWM3 Fault Status 1 (PWM3FLTSTAT1), offset 0x988

Along with the **PWMnFLTSTAT0** register, this register provides status regarding the fault condition inputs.

If the **LATCH** bit in the **PWMnCTL** register is clear, the contents of the **PWMnFLTSTAT1** register are read-only (RO) and provide the current state of the digital comparator triggers.

If the **LATCH** bit in the **PWMnCTL** register is set, the contents of the **PWMnFLTSTAT1** register are read / write 1 to clear (RW1C) and provide a latched version of the digital comparator triggers. In this mode, the register bits are cleared by writing a 1 to a set bit. The contents of this register can only be written if the fault source extensions are enabled (the **FLTSRC** bit in the **PWMnCTL** register is set).

Note: The fault status registers, **PWMnFLTSTAT0** and **PWMnFLTSTAT1**, reflect the status of all fault sources, regardless of what fault sources are enabled for that particular generator.

PWMn Fault Status 1 (PWMnFLTSTAT1)

PWM0 base: 0x4002.8000
Offset 0x808
Type -, reset 0x0000.0000

	31	30	29	28	27	26	25	24	23	22	21	20	19	18	17	16
	reserved															
Type	RO	RO	RO	RO	RO	RO	RO	RO	RO	RO	RO	RO	RO	RO	RO	RO
Reset	0	0	0	0	0	0	0	0	0	0	0	0	0	0	0	0
	15	14	13	12	11	10	9	8	7	6	5	4	3	2	1	0
	reserved								DCMP7	DCMP6	DCMP5	DCMP4	DCMP3	DCMP2	DCMP1	DCMP0
Type	RO	RO	RO	RO	RO	RO	RO	RO	-	-	-	-	-	-	-	-
Reset	0	0	0	0	0	0	0	0	0	0	0	0	0	0	0	0

Bit/Field	Name	Type	Reset	Description
31:8	reserved	RO	0x0000.00	Software should not rely on the value of a reserved bit. To provide compatibility with future products, the value of a reserved bit should be preserved across a read-modify-write operation.
7	DCMP7	-	0	<p>Digital Comparator 7 Trigger</p> <p>If the PWMnCTL register LATCH bit is clear, this bit represents the current state of the Digital Comparator 7 trigger input.</p> <p>If the PWMnCTL register LATCH bit is set, this bit represents a sticky version of the trigger.</p> <ul style="list-style-type: none"> ■ If DCMP7 is set, the trigger transitioned to the active state previously. ■ If DCMP7 is clear, the trigger has not transitioned to the active state since the last time it was cleared. ■ The DCMP7 bit is cleared by writing it with the value 1.

Bit/Field	Name	Type	Reset	Description
6	DCMP6	-	0	<p>Digital Comparator 6 Trigger</p> <p>If the PWMnCTL register <i>LATCH</i> bit is clear, this bit represents the current state of the Digital Comparator 6 trigger input.</p> <p>If the PWMnCTL register <i>LATCH</i> bit is set, this bit represents a sticky version of the trigger.</p> <ul style="list-style-type: none"> ■ If DCMP6 is set, the trigger transitioned to the active state previously. ■ If DCMP6 is clear, the trigger has not transitioned to the active state since the last time it was cleared. ■ The DCMP6 bit is cleared by writing it with the value 1.
5	DCMP5	-	0	<p>Digital Comparator 5 Trigger</p> <p>If the PWMnCTL register <i>LATCH</i> bit is clear, this bit represents the current state of the Digital Comparator 5 trigger input.</p> <p>If the PWMnCTL register <i>LATCH</i> bit is set, this bit represents a sticky version of the trigger.</p> <ul style="list-style-type: none"> ■ If DCMP5 is set, the trigger transitioned to the active state previously. ■ If DCMP5 is clear, the trigger has not transitioned to the active state since the last time it was cleared. ■ The DCMP5 bit is cleared by writing it with the value 1.
4	DCMP4	-	0	<p>Digital Comparator 4 Trigger</p> <p>If the PWMnCTL register <i>LATCH</i> bit is clear, this bit represents the current state of the Digital Comparator 4 trigger input.</p> <p>If the PWMnCTL register <i>LATCH</i> bit is set, this bit represents a sticky version of the trigger.</p> <ul style="list-style-type: none"> ■ If DCMP4 is set, the trigger transitioned to the active state previously. ■ If DCMP4 is clear, the trigger has not transitioned to the active state since the last time it was cleared. ■ The DCMP4 bit is cleared by writing it with the value 1.
3	DCMP3	-	0	<p>Digital Comparator 3 Trigger</p> <p>If the PWMnCTL register <i>LATCH</i> bit is clear, this bit represents the current state of the Digital Comparator 3 trigger input.</p> <p>If the PWMnCTL register <i>LATCH</i> bit is set, this bit represents a sticky version of the trigger.</p> <ul style="list-style-type: none"> ■ If DCMP3 is set, the trigger transitioned to the active state previously. ■ If DCMP3 is clear, the trigger has not transitioned to the active state since the last time it was cleared. ■ The DCMP3 bit is cleared by writing it with the value 1.

Bit/Field	Name	Type	Reset	Description
2	DCMP2	-	0	<p>Digital Comparator 2 Trigger</p> <p>If the PWMnCTL register <i>LATCH</i> bit is clear, this bit represents the current state of the Digital Comparator 2 trigger input.</p> <p>If the PWMnCTL register <i>LATCH</i> bit is set, this bit represents a sticky version of the trigger.</p> <ul style="list-style-type: none"> ■ If DCMP2 is set, the trigger transitioned to the active state previously. ■ If DCMP2 is clear, the trigger has not transitioned to the active state since the last time it was cleared. ■ The DCMP2 bit is cleared by writing it with the value 1.
1	DCMP1	-	0	<p>Digital Comparator 1 Trigger</p> <p>If the PWMnCTL register <i>LATCH</i> bit is clear, this bit represents the current state of the Digital Comparator 1 trigger input.</p> <p>If the PWMnCTL register <i>LATCH</i> bit is set, this bit represents a sticky version of the trigger.</p> <ul style="list-style-type: none"> ■ If DCMP1 is set, the trigger transitioned to the active state previously. ■ If DCMP1 is clear, the trigger has not transitioned to the active state since the last time it was cleared. ■ The DCMP1 bit is cleared by writing it with the value 1.
0	DCMP0	-	0	<p>Digital Comparator 0 Trigger</p> <p>If the PWMnCTL register <i>LATCH</i> bit is clear, this bit represents the current state of the Digital Comparator 0 trigger input.</p> <p>If the PWMnCTL register <i>LATCH</i> bit is set, this bit represents a sticky version of the trigger.</p> <ul style="list-style-type: none"> ■ If DCMP0 is set, the trigger transitioned to the active state previously. ■ If DCMP0 is clear, the trigger has not transitioned to the active state since the last time it was cleared. ■ The DCMP0 bit is cleared by writing it with the value 1.

Register 88: PWM Peripheral Properties (PWMPP), offset 0xFC0

The **PWMPP** register provides information regarding the properties of the PWM module.

PWM Peripheral Properties (PWMPP)

PWM0 base: 0x4002.8000

Offset 0xFC0

Type RO, reset 0x0000.0344

	31	30	29	28	27	26	25	24	23	22	21	20	19	18	17	16
	reserved															
Type	RO	RO	RO	RO	RO	RO	RO	RO	RO	RO	RO	RO	RO	RO	RO	RO
Reset	0	0	0	0	0	0	0	0	0	0	0	0	0	0	0	0
	15	14	13	12	11	10	9	8	7	6	5	4	3	2	1	0
	reserved				ONE	EFAULT	ESYNC	FCNT					GCNT			
Type	RO	RO	RO	RO	RO	RO	RO	RO	RO	RO	RO	RO	RO	RO	RO	RO
Reset	0	0	0	0	0	0	1	1	0	1	0	0	0	0	1	0

Bit/Field	Name	Type	Reset	Description
31:11	reserved	RO	0x0	Software should not rely on the value of a reserved bit. To provide compatibility with future products, the value of a reserved bit should be preserved across a read-modify-write operation.
10	ONE	RO	0x0	One-Shot Mode Value Description 0 One-shot modes are not available. 1 One-shot modes are available.
9	EFAULT	RO	0x1	Extended Fault Value Description 0 Extended fault capabilities are not available. 1 Extended fault capabilities are available.
8	ESYNC	RO	0x1	Extended Synchronization Value Description 0 Extended synchronization is not available. 1 Extended synchronization is available.
7:4	FCNT	RO	0x4	Fault Inputs Value Description 0x0 No fault inputs. 0x1 1 fault input. 0x2 2 fault input. 0x3 3 fault input. 0x4 4 fault input. 0x5 - 0xF reserved

Bit/Field	Name	Type	Reset	Description
3:0	GCNT	RO	0x4	Generators

Value	Description
0x0	No generators.
0x1	1 generator
0x2	2 generators
0x3	3 generators
0x4	4 generators
0x5 - 0xF	reserved

The number of PWM outputs is 2 times the number of PWM generators.

Register 89: PWM Clock Configuration (PWMCC), offset 0xFC8

The **PWMCC** register controls the clock source for the PWM module.

PWM Clock Configuration (PWMCC)

PWM0 base: 0x4002.8000

Offset 0xFC8

Type RW, reset 0x0000.0005

	31	30	29	28	27	26	25	24	23	22	21	20	19	18	17	16
	reserved															
Type	RO	RO	RO	RO	RO	RO	RO	RO	RO	RO	RO	RO	RO	RO	RO	RO
Reset	0	0	0	0	0	0	0	0	0	0	0	0	0	0	0	0
	15	14	13	12	11	10	9	8	7	6	5	4	3	2	1	0
	reserved							USEPWM	reserved					PWMDIV		
Type	RO	RO	RO	RO	RO	RO	RO	RW	RO	RO	RO	RO	RO	RW	RW	RW
Reset	0	0	0	0	0	0	0	0	0	0	0	0	0	1	0	1

Bit/Field	Name	Type	Reset	Description
31:9	reserved	RO	0x0000.0000	Software should not rely on the value of a reserved bit. To provide compatibility with future products, the value of a reserved bit should be preserved across a read-modify-write operation.
8	USEPWM	RW	0x0	Use PWM Clock Divisor Value Description 0 The system clock is the source of PWM unit clock. 1 The PWM clock divider is the source of PWM unit clock.
7:3	reserved	RO	0	Software should not rely on the value of a reserved bit. To provide compatibility with future products, the value of a reserved bit should be preserved across a read-modify-write operation.
2:0	PWMDIV	RW	0x5	PWM Clock Divider This field specifies the PWM clock frequency as a division of the system clock. Value Description 0x0 /2 0x1 /4 0x2 /8 0x3 /16 0x4 /32 0x5 /64 0x6 - 0x7 reserved

27 Quadrature Encoder Interface (QEI)

A quadrature encoder, also known as a 2-channel incremental encoder, converts linear displacement into a pulse signal. By monitoring both the number of pulses and the relative phase of the two signals, you can track the position, direction of rotation, and speed. In addition, a third channel, or index signal, can be used to reset the position counter.

The TM4C129ENCPDT quadrature encoder interface (QEI) module interprets the code produced by a quadrature encoder wheel to integrate position over time and determine direction of rotation. In addition, it can capture a running estimate of the velocity of the encoder wheel.

The TM4C129ENCPDT microcontroller includes one QEI module with the following features:

- Position integrator that tracks the encoder position
- Programmable noise filter on the inputs
- Velocity capture using built-in timer
- The input frequency of the QEI inputs may be as high as 1/4 of the processor frequency (for example, 12.5 MHz for a 50-MHz system)
- Interrupt generation on:
 - Index pulse
 - Velocity-timer expiration
 - Direction change
 - Quadrature error detection

27.1 Block Diagram

Figure 27-1 on page 1873 provides an internal block diagram of a TM4C129ENCPDT QEI module. The PhA and PhB inputs shown in this diagram are the internal signals that enter the Quadrature Encoder after the external signals, $PhAn$ and $PhBn$, have passed through inversion and swapping logic shown in Figure 27-2 on page 1874. The QEI module has the option of inverting and/or swapping the incoming signals.

Note: Any references in this chapter to PhA and PhB refer to the internal PhA and PhB inputs that enter the Quadrature Encoder after the external signals, $PhAn$ and $PhBn$, have passed through inversion and swapping logic that is enabled through the **QEI Control (QEICTL)** register.

Figure 27-1. QEI Block Diagram

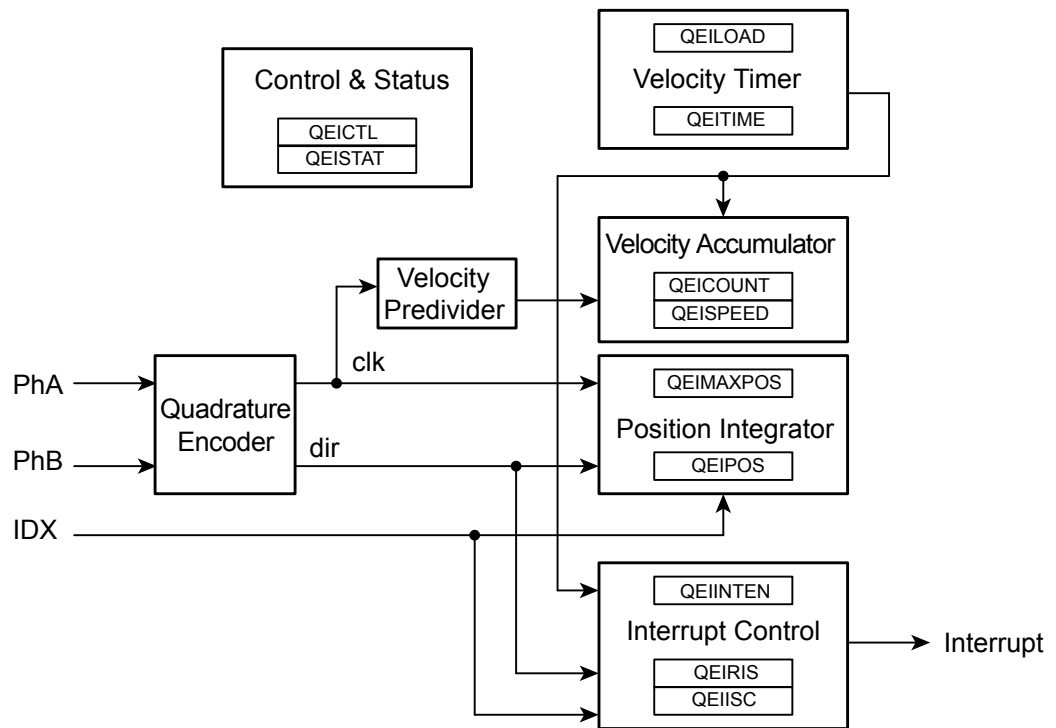
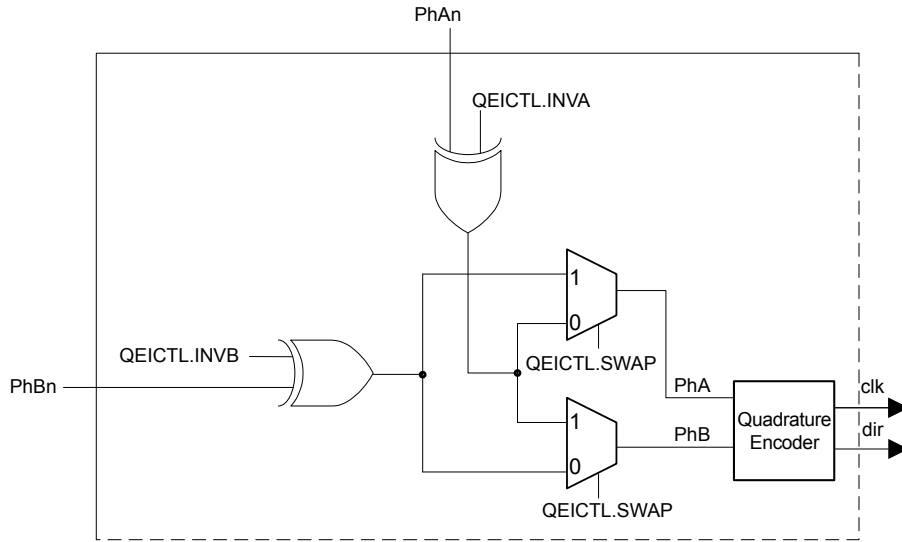

Figure 27-2 on page 1874 shows the logic that is provided to allow the `PhAn` and `PhBn` signals to be inverted and/or swapped.

Figure 27-2. QEI Input Signal Logic



27.2 Signal Description

The following table lists the external signals of the QEI module and describes the function of each. The QEI signals are alternate functions for some GPIO signals and default to be GPIO signals at reset. The column in the table below titled "Pin Mux/Pin Assignment" lists the possible GPIO pin placements for these QEI signals. The **AFSEL** bit in the **GPIO Alternate Function Select (GPIOAFSEL)** register (page 778) should be set to choose the QEI function. The number in parentheses is the encoding that must be programmed into the **PMCn** field in the **GPIO Port Control (GPIOCTL)** register (page 795) to assign the QEI signal to the specified GPIO port pin. For more information on configuring GPIOs, see "General-Purpose Input/Outputs (GPIOs)" on page 750.

Table 27-1. QEI Signals (128TQFP)

Pin Name	Pin Number	Pin Mux / Pin Assignment	Pin Type	Buffer Type	Description
IDX0	84	PL3 (6)	I	TTL	QEI module 0 index.
PhA0	82	PL1 (6)	I	TTL	QEI module 0 phase A.
PhB0	83	PL2 (6)	I	TTL	QEI module 0 phase B.

27.3 Functional Description

The QEI module interprets the two-bit gray code produced by a quadrature encoder wheel to integrate position over time and determine direction of rotation. In addition, it can capture a running estimate of the velocity of the encoder wheel.

The position integrator and velocity capture can be independently enabled, though the position integrator must be enabled before the velocity capture can be enabled. The two phase signals, **PhAn** and **PhBn**, can be swapped before being interpreted by the QEI module to change the meaning

of forward and backward and to correct for miswiring of the system. Alternatively, the phase signals can be interpreted as a clock and direction signal as output by some encoders.

The QEI module input signals have a digital noise filter on them that can be enabled to prevent spurious operation. The noise filter requires that the inputs be stable for a specified number of consecutive clock cycles before updating the edge detector. The filter is enabled by the `FILTEN` bit in the **QEI Control (QEICTL)** register. The frequency of the input update is programmable using the `FILTCNT` bit field in the **QEICTL** register.

The QEI module supports two modes of signal operation: quadrature phase mode and clock/direction mode. In quadrature phase mode, the encoder produces two clocks that are 90 degrees out of phase; the edge relationship is used to determine the direction of rotation. In clock/direction mode, the encoder produces a clock signal to indicate steps and a direction signal to indicate the direction of rotation. This mode is determined by the `SIGMODE` bit of the **QEICTL** register (see page 1879).

When the QEI module is set to use the quadrature phase mode (`SIGMODE` bit is clear), the capture mode for the position integrator can be set to update the position counter on every edge of the `PhA` signal or to update on every edge of both `PhA` and `PhB`. Updating the position counter on every `PhA` and `PhB` edge provides more positional resolution at the cost of less range in the positional counter.

When edges on `PhA` lead edges on `PhB`, the position counter is incremented. When edges on `PhB` lead edges on `PhA`, the position counter is decremented. When a rising and falling edge pair is seen on one of the phases without any edges on the other, the direction of rotation has changed.

The positional counter is automatically reset on one of two conditions: sensing the index pulse or reaching the maximum position value. The reset mode is determined by the `RESMODE` bit of the **QEICTL** register.

When `RESMODE` is set, the positional counter is reset when the index pulse is sensed. This mode limits the positional counter to the values $[0:N-1]$, where N is the number of phase edges in a full revolution of the encoder wheel. The **QEI Maximum Position (QEIMAXPOS)** register must be programmed with $N-1$ so that the reverse direction from position 0 can move the position counter to $N-1$. In this mode, the position register contains the absolute position of the encoder relative to the index (or home) position once an index pulse has been seen.

When `RESMODE` is clear, the positional counter is constrained to the range $[0:M]$, where M is the programmable maximum value. The index pulse is ignored by the positional counter in this mode.

Velocity capture uses a configurable timer and a count register. The timer counts the number of phase edges (using the same configuration as for the position integrator) in a given time period. The edge count from the previous time period is available to the controller via the **QEI Velocity (QEISPEED)** register, while the edge count for the current time period is being accumulated in the **QEI Velocity Counter (QEICOUNT)** register. As soon as the current time period is complete, the total number of edges counted in that time period is made available in the **QEISPEED** register (overwriting the previous value), the **QEICOUNT** register is cleared, and counting commences on a new time period. The number of edges counted in a given time period is directly proportional to the velocity of the encoder.

Figure 27-3 on page 1876 shows how the TM4C129ENC PDT quadrature encoder converts the phase input signals into clock pulses, the direction signal, and how the velocity predivider operates (in Divide by 4 mode).

Figure 27-3. Quadrature Encoder and Velocity Predivider Operation

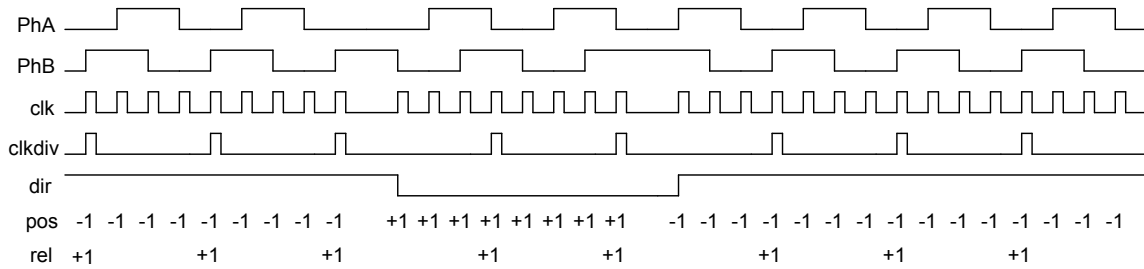

The period of the timer is configurable by specifying the load value for the timer in the **QEI Timer Load (QEILOAD)** register. When the timer reaches zero, an interrupt can be triggered, and the hardware reloads the timer with the **QEILOAD** value and continues to count down. At lower encoder speeds, a longer timer period is required to be able to capture enough edges to have a meaningful result. At higher encoder speeds, both a shorter timer period and/or the velocity predivider can be used.

The following equation converts the velocity counter value into an rpm value:

$$\text{rpm} = (\text{clock} * (2 \wedge \text{VELDIV}) * \text{SPEED} * 60) \div (\text{LOAD} * \text{ppr} * \text{edges})$$

where:

clock is the controller clock rate

ppr is the number of pulses per revolution of the physical encoder

edges is 2 or 4, based on the capture mode set in the **QEICTL** register (2 for CAPMODE clear and 4 for CAPMODE set)

For example, consider a motor running at 600 rpm. A 2048 pulse per revolution quadrature encoder is attached to the motor, producing 8192 phase edges per revolution. With a velocity predivider of ÷1 (VELDIV is clear) and clocking on both PhA and PhB edges, this results in 81,920 pulses per second (the motor turns 10 times per second). If the timer were clocked at 10,000 Hz, and the load value was 2,500 (¼ of a second), it would count 20,480 pulses per update. Using the above equation:

$$\text{rpm} = (10000 * 1 * 20480 * 60) \div (2500 * 2048 * 4) = 600 \text{ rpm}$$

Now, consider that the motor is sped up to 3000 rpm. This results in 409,600 pulses per second, or 102,400 every ¼ of a second. Again, the above equation gives:

$$\text{rpm} = (10000 * 1 * 102400 * 60) \div (2500 * 2048 * 4) = 3000 \text{ rpm}$$

Care must be taken when evaluating this equation because intermediate values may exceed the capacity of a 32-bit integer. In the above examples, the clock is 10,000 and the divider is 2,500; both could be predivided by 100 (at compile time if they are constants) and therefore be 100 and 25. In fact, if they were compile-time constants, they could also be reduced to a simple multiply by 4, cancelled by the ÷4 for the edge-count factor.

Important: Reducing constant factors at compile time is the best way to control the intermediate values of this equation and reduce the processing requirement of computing this equation.

The division can be avoided by selecting a timer load value such that the divisor is a power of 2; a simple shift can therefore be done in place of the division. For encoders with a power of 2 pulses per revolution, the load value can be a power of 2. For other encoders, a load value must be selected such that the product is very close to a power of 2. For example, a 100 pulse-per-revolution encoder

could use a load value of 82, resulting in 32,800 as the divisor, which is 0.09% above 2^{14} . In this case a shift by 15 would be an adequate approximation of the divide in most cases. If absolute accuracy were required, the microcontroller's divide instruction could be used.

The QEI module can produce a controller interrupt on several events: phase error, direction change, reception of the index pulse, and expiration of the velocity timer. Standard masking, raw interrupt status, interrupt status, and interrupt clear capabilities are provided.

27.4 Initialization and Configuration

The following example shows how to configure the Quadrature Encoder module to read back an absolute position:

1. Enable the QEI clock using the **RCGCQEI** register in the System Control module (see page 406).
2. Enable the clock to the appropriate GPIO module via the **RCGCGPIO** register in the System Control module (see page 389).
3. In the GPIO module, enable the appropriate pins for their alternate function using the **GPIOAFSEL** register. To determine which GPIOs to configure, see Table 29-4 on page 1921.
4. Configure the **PMC_n** fields in the **GPIOPCTL** register to assign the QEI signals to the appropriate pins (see page 795 and Table 29-5 on page 1932).
5. Configure the quadrature encoder to capture edges on both signals and maintain an absolute position by resetting on index pulses. A 1000-line encoder with four edges per line, results in 4000 pulses per revolution; therefore, set the maximum position to 3999 (0xF9F) as the count is zero-based.
 - Write the **QEICTL** register with the value of 0x0000.0018.
 - Write the **QEIMAXPOS** register with the value of 0x0000.0F9F.
6. Enable the quadrature encoder by setting bit 0 of the **QEICTL** register.

Note: Once the QEI module has been enabled by setting the **ENABLE** bit in the **QEICTL** register, it cannot be disabled. The only way to clear the **ENABLE** bit is to reset the module using the **Quadrature Encoder Interface Software Reset (SRQEI)** register.
7. Delay until the encoder position is required.
8. Read the encoder position by reading the **QEI Position (QEIPOS)** register value.

Note: If the application requires the quadrature encoder to have a specific initial position, this value must be programmed in the **QEIPOS** register after the quadrature encoder has been enabled by setting the **ENABLE** bit in the **QEICTL** register.

27.5 Register Map

Table 27-2 on page 1878 lists the QEI registers. The offset listed is a hexadecimal increment to the register's address, relative to the module's base address:

- QEI0: 0x4002.C000

Note that the QEI module clock must be enabled before the registers can be programmed (see page 406). There must be a delay of 3 system clocks after the QEI module clock is enabled before any QEI module registers are accessed.

Table 27-2. QEI Register Map

Offset	Name	Type	Reset	Description	See page
0x000	QEICTL	RW	0x0000.0000	QEI Control	1879
0x004	QEISTAT	RO	0x0000.0000	QEI Status	1882
0x008	QEIPOS	RW	0x0000.0000	QEI Position	1883
0x00C	QEIMAXPOS	RW	0x0000.0000	QEI Maximum Position	1884
0x010	QEILOAD	RW	0x0000.0000	QEI Timer Load	1885
0x014	QEITIME	RO	0x0000.0000	QEI Timer	1886
0x018	QEICOUNT	RO	0x0000.0000	QEI Velocity Counter	1887
0x01C	QEISPEED	RO	0x0000.0000	QEI Velocity	1888
0x020	QEIINTEN	RW	0x0000.0000	QEI Interrupt Enable	1889
0x024	QEIRIS	RO	0x0000.0000	QEI Raw Interrupt Status	1891
0x028	QEIISC	RW1C	0x0000.0000	QEI Interrupt Status and Clear	1893

27.6 Register Descriptions

The remainder of this section lists and describes the QEI registers, in numerical order by address offset.

Register 1: QEI Control (QEICTL), offset 0x000

This register contains the configuration of the QEI module. Separate enables are provided for the quadrature encoder and the velocity capture blocks; the quadrature encoder must be enabled in order to capture the velocity, but the velocity does not need to be captured in applications that do not need it. The phase signal interpretation, phase swap, Position Update mode, Position Reset mode, and velocity predivider are all set via this register.

QEI Control (QEICTL)

QEI0 base: 0x4002.C000

Offset 0x000

Type RW, reset 0x0000.0000

	31	30	29	28	27	26	25	24	23	22	21	20	19	18	17	16
	reserved												FILTCNT			
Type	RO	RO	RO	RO	RO	RO	RO	RO	RO	RO	RO	RO	RW	RW	RW	RW
Reset	0	0	0	0	0	0	0	0	0	0	0	0	0	0	0	0
	15	14	13	12	11	10	9	8	7	6	5	4	3	2	1	0
	reserved		FILTEN	STALLEN	INVI	INVB	INVA	VELDIV			VELEN	RESMODE	CAPMODE	SIGMODE	SWAP	ENABLE
Type	RO	RO	RW	RW	RW	RW	RW	RW	RW	RW	RW	RW	RW	RW	RW	RW
Reset	0	0	0	0	0	0	0	0	0	0	0	0	0	0	0	0

Bit/Field	Name	Type	Reset	Description
31:20	reserved	RO	0x000	Software should not rely on the value of a reserved bit. To provide compatibility with future products, the value of a reserved bit should be preserved across a read-modify-write operation.
19:16	FILTCNT	RW	0x0	Input Filter Prescale Count This field controls the frequency of the input update. When this field is clear, the input is sampled after 2 system clocks. When this field is 0x1, the input is sampled after 3 system clocks. Similarly, when this field is 0xF, the input is sampled after 17 clocks.
15:14	reserved	RO	0x0	Software should not rely on the value of a reserved bit. To provide compatibility with future products, the value of a reserved bit should be preserved across a read-modify-write operation.
13	FILTEN	RW	0	Enable Input Filter Value Description 0 The QEI inputs are not filtered. 1 Enables the digital noise filter on the QEI input signals. Inputs must be stable for 3 consecutive clock edges before the edge detector is updated.
12	STALLEN	RW	0	Stall QEI Value Description 0 The QEI module does not stall when the microcontroller is stopped by a debugger. 1 The QEI module stalls when the microcontroller is stopped by a debugger.

Bit/Field	Name	Type	Reset	Description
11	INVI	RW	0	<p>Invert Index Pulse</p> <p>Value Description</p> <p>0 No effect.</p> <p>1 Inverts the <code>IDX</code> input.</p>
10	INVB	RW	0	<p>Invert PhB</p> <p>Value Description</p> <p>0 No effect.</p> <p>1 Inverts the <code>PhBn</code> input.</p>
9	INVA	RW	0	<p>Invert PhA</p> <p>Value Description</p> <p>0 No effect.</p> <p>1 Inverts the <code>PhAn</code> input.</p>
8:6	VELDIV	RW	0x0	<p>Predivide Velocity</p> <p>This field defines the predivider of the input quadrature pulses before being applied to the QEICOUNT accumulator.</p> <p>Value Predivider</p> <p>0x0 ÷1</p> <p>0x1 ÷2</p> <p>0x2 ÷4</p> <p>0x3 ÷8</p> <p>0x4 ÷16</p> <p>0x5 ÷32</p> <p>0x6 ÷64</p> <p>0x7 ÷128</p>
5	VELEN	RW	0	<p>Capture Velocity</p> <p>Value Description</p> <p>0 No effect.</p> <p>1 Enables capture of the velocity of the quadrature encoder.</p>
4	RESMODE	RW	0	<p>Reset Mode</p> <p>Value Description</p> <p>0 The position counter is reset when it reaches the maximum as defined by the <code>MAXPOS</code> field in the QEIMAXPOS register.</p> <p>1 The position counter is reset when the index pulse is captured.</p>

Bit/Field	Name	Type	Reset	Description
3	CAPMODE	RW	0	<p>Capture Mode</p> <p>Note: When SIGMODE=1, the CAPMODE setting is not applicable and is reserved.</p> <p>Value Description</p> <p>0 Only the PhA edges are counted.</p> <p>1 The PhA and PhB edges are counted, providing twice the positional resolution but half the range.</p>
2	SIGMODE	RW	0	<p>Signal Mode</p> <p>Value Description</p> <p>0 The internal PhA and PhB signals operate as quadrature phase signals.</p> <p>1 The internal PhA input operates as the clock (CLK) signal and the internal PhB input operates as the direction (DIR) signal.</p>
1	SWAP	RW	0	<p>Swap Signals</p> <p>Note if the INVA or INVB bit are set, the inversion of the signals occur prior to the swap.</p> <p>Value Description</p> <p>0 No effect.</p> <p>1 Swaps the PhAn and PhBn signals.</p>
0	ENABLE	RW	0	<p>Enable QEI</p> <p>Value Description</p> <p>0 No effect.</p> <p>1 Enables the quadrature encoder module.</p> <p>Note: Once the QEI module has been enabled by setting the ENABLE bit, it cannot be disabled. The only way to clear the ENABLE bit is to reset the module using the Quadrature Encoder Interface Software Reset (SRQEI) register.</p>

Register 2: QEI Status (QEISTAT), offset 0x004

This register provides status about the operation of the QEI module.

QEI Status (QEISTAT)

QEI0 base: 0x4002.C000

Offset 0x004

Type RO, reset 0x0000.0000

	31	30	29	28	27	26	25	24	23	22	21	20	19	18	17	16	
	reserved																
Type	RO	RO	RO	RO	RO	RO	RO	RO	RO	RO	RO	RO	RO	RO	RO	RO	
Reset	0	0	0	0	0	0	0	0	0	0	0	0	0	0	0	0	
	15	14	13	12	11	10	9	8	7	6	5	4	3	2	1	0	
	reserved															DIRECTION	ERROR
Type	RO	RO	RO	RO	RO	RO	RO	RO	RO	RO	RO	RO	RO	RO	RO	RO	RO
Reset	0	0	0	0	0	0	0	0	0	0	0	0	0	0	0	0	0

Bit/Field	Name	Type	Reset	Description						
31:2	reserved	RO	0x0000.000	Software should not rely on the value of a reserved bit. To provide compatibility with future products, the value of a reserved bit should be preserved across a read-modify-write operation.						
1	DIRECTION	RO	0	<p>Direction of Rotation</p> <p>Indicates the direction the encoder is rotating.</p> <table border="1"> <thead> <tr> <th>Value</th> <th>Description</th> </tr> </thead> <tbody> <tr> <td>0</td> <td>The encoder is rotating forward.</td> </tr> <tr> <td>1</td> <td>The encoder is rotating in reverse.</td> </tr> </tbody> </table>	Value	Description	0	The encoder is rotating forward.	1	The encoder is rotating in reverse.
Value	Description									
0	The encoder is rotating forward.									
1	The encoder is rotating in reverse.									
0	ERROR	RO	0	<p>Error Detected</p> <table border="1"> <thead> <tr> <th>Value</th> <th>Description</th> </tr> </thead> <tbody> <tr> <td>0</td> <td>No error.</td> </tr> <tr> <td>1</td> <td>An error was detected in the gray code sequence (that is, both signals changing at the same time).</td> </tr> </tbody> </table>	Value	Description	0	No error.	1	An error was detected in the gray code sequence (that is, both signals changing at the same time).
Value	Description									
0	No error.									
1	An error was detected in the gray code sequence (that is, both signals changing at the same time).									

Register 3: QEI Position (QEIP0S), offset 0x008

This register contains the current value of the position integrator. The value is updated by the status of the QEI phase inputs and can be set to a specific value by writing to it.

QEI Position (QEIP0S)

QEI0 base: 0x4002.C000

Offset 0x008

Type RW, reset 0x0000.0000

	31	30	29	28	27	26	25	24	23	22	21	20	19	18	17	16
	POSITION															
Type	RW	RW	RW	RW	RW	RW	RW	RW	RW	RW	RW	RW	RW	RW	RW	RW
Reset	0	0	0	0	0	0	0	0	0	0	0	0	0	0	0	0
	15	14	13	12	11	10	9	8	7	6	5	4	3	2	1	0
	POSITION															
Type	RW	RW	RW	RW	RW	RW	RW	RW	RW	RW	RW	RW	RW	RW	RW	RW
Reset	0	0	0	0	0	0	0	0	0	0	0	0	0	0	0	0

Bit/Field	Name	Type	Reset	Description
31:0	POSITION	RW	0x0000.0000	Current Position Integrator Value The current value of the position integrator.

Register 4: QEI Maximum Position (QEIMAXPOS), offset 0x00C

This register contains the maximum value of the position integrator. When moving forward, the position register resets to zero when it increments past this value. When moving in reverse, the position register resets to this value when it decrements from zero.

QEI Maximum Position (QEIMAXPOS)

QEI0 base: 0x4002.C000
 Offset 0x00C
 Type RW, reset 0x0000.0000

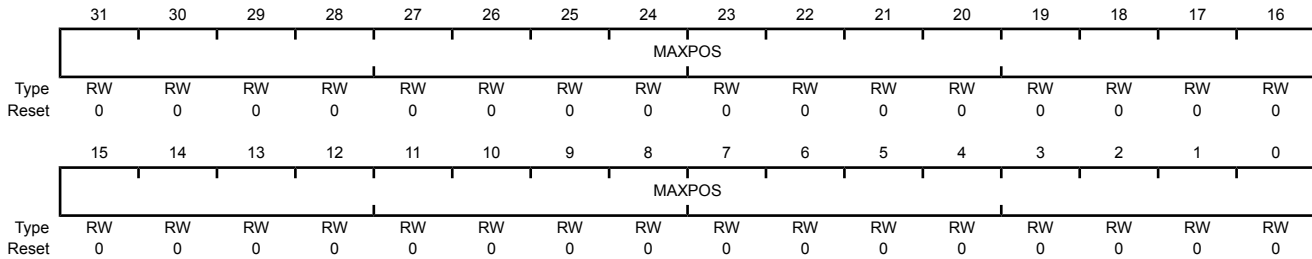

Bit/Field	Name	Type	Reset	Description
31:0	MAXPOS	RW	0x0000.0000	Maximum Position Integrator Value The maximum value of the position integrator.

Register 5: QEI Timer Load (QEILOAD), offset 0x010

This register contains the load value for the velocity timer. Because this value is loaded into the timer on the clock cycle after the timer is zero, this value should be one less than the number of clocks in the desired period. So, for example, to have 2000 decimal clocks per timer period, this register should contain 1999 decimal.

QEI Timer Load (QEILOAD)

QEI0 base: 0x4002.C000

Offset 0x010

Type RW, reset 0x0000.0000

	31	30	29	28	27	26	25	24	23	22	21	20	19	18	17	16
	LOAD															
Type	RW	RW	RW	RW	RW	RW	RW	RW	RW	RW	RW	RW	RW	RW	RW	RW
Reset	0	0	0	0	0	0	0	0	0	0	0	0	0	0	0	0
	15	14	13	12	11	10	9	8	7	6	5	4	3	2	1	0
	LOAD															
Type	RW	RW	RW	RW	RW	RW	RW	RW	RW	RW	RW	RW	RW	RW	RW	RW
Reset	0	0	0	0	0	0	0	0	0	0	0	0	0	0	0	0

Bit/Field	Name	Type	Reset	Description
31:0	LOAD	RW	0x0000.0000	Velocity Timer Load Value The load value for the velocity timer.

Register 6: QEI Timer (QEITIME), offset 0x014

This register contains the current value of the velocity timer. This counter does not increment when the VELEN bit in the QEICTL register is clear.

QEI Timer (QEITIME)

QEI0 base: 0x4002.C000

Offset 0x014

Type RO, reset 0x0000.0000

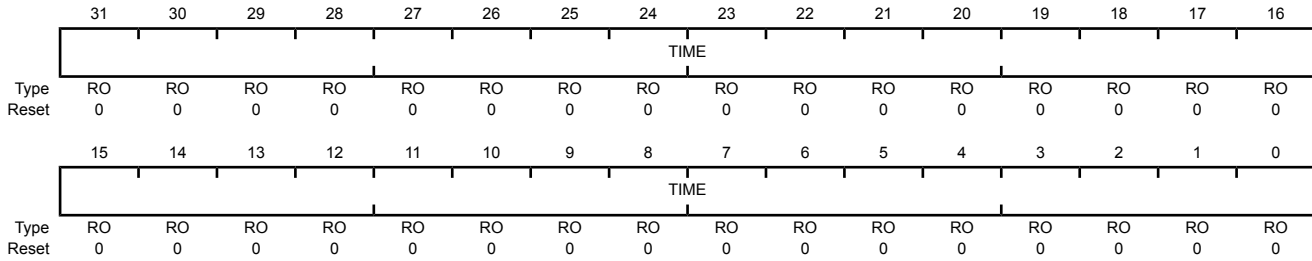

Bit/Field	Name	Type	Reset	Description
31:0	TIME	RO	0x0000.0000	Velocity Timer Current Value The current value of the velocity timer.

Register 7: QEI Velocity Counter (QEICOUNT), offset 0x018

This register contains the running count of velocity pulses for the current time period. Because this count is a running total, the time period to which it applies cannot be known with precision (that is, a read of this register does not necessarily correspond to the time returned by the **QEITIME** register because there is a small window of time between the two reads, during which either value may have changed). The **QEISPEED** register should be used to determine the actual encoder velocity; this register is provided for information purposes only. This counter does not increment when the **VELEN** bit in the **QEICTL** register is clear.

QEI Velocity Counter (QEICOUNT)

QEI0 base: 0x4002.C000

Offset 0x018

Type RO, reset 0x0000.0000

	31	30	29	28	27	26	25	24	23	22	21	20	19	18	17	16
	COUNT															
Type	RO	RO	RO	RO	RO	RO	RO	RO	RO	RO	RO	RO	RO	RO	RO	RO
Reset	0	0	0	0	0	0	0	0	0	0	0	0	0	0	0	0
	15	14	13	12	11	10	9	8	7	6	5	4	3	2	1	0
	COUNT															
Type	RO	RO	RO	RO	RO	RO	RO	RO	RO	RO	RO	RO	RO	RO	RO	RO
Reset	0	0	0	0	0	0	0	0	0	0	0	0	0	0	0	0

Bit/Field	Name	Type	Reset	Description
31:0	COUNT	RO	0x0000.0000	Velocity Pulse Count The running total of encoder pulses during this velocity timer period.

Register 8: QEI Velocity (QEISPEED), offset 0x01C

This register contains the most recently measured velocity of the quadrature encoder. This value corresponds to the number of velocity pulses counted in the previous velocity timer period. This register does not update when the `VELEN` bit in the `QEICTL` register is clear.

QEI Velocity (QEISPEED)

QEI0 base: 0x4002.C000
 Offset 0x01C
 Type RO, reset 0x0000.0000

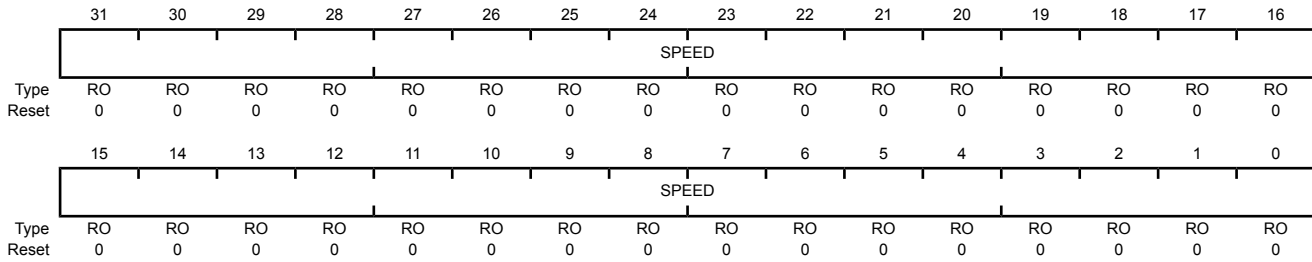

Bit/Field	Name	Type	Reset	Description
31:0	SPEED	RO	0x0000.0000	Velocity The measured speed of the quadrature encoder in pulses per period.

Register 9: QEI Interrupt Enable (QEIINTEN), offset 0x020

This register contains enables for each of the QEI module interrupts. An interrupt is asserted to the interrupt controller if the corresponding bit in this register is set.

QEI Interrupt Enable (QEIINTEN)

QEI0 base: 0x4002.C000

Offset 0x020

Type RW, reset 0x0000.0000

	31	30	29	28	27	26	25	24	23	22	21	20	19	18	17	16	
	reserved																
Type	RO	RO	RO	RO	RO	RO	RO	RO	RO	RO	RO	RO	RO	RO	RO	RO	
Reset	0	0	0	0	0	0	0	0	0	0	0	0	0	0	0	0	
	15	14	13	12	11	10	9	8	7	6	5	4	3	2	1	0	
	reserved												INTERROR	INTDIR	INTTIMER	INTINDEX	
Type	RO	RO	RO	RO	RO	RO	RO	RO	RO	RO	RO	RO	RO	RW	RW	RW	RW
Reset	0	0	0	0	0	0	0	0	0	0	0	0	0	0	0	0	0

Bit/Field	Name	Type	Reset	Description
31:4	reserved	RO	0x0000.000	Software should not rely on the value of a reserved bit. To provide compatibility with future products, the value of a reserved bit should be preserved across a read-modify-write operation.
3	INTERROR	RW	0	Phase Error Interrupt Enable Note: The <code>INTERROR</code> bit is only applicable when the QEI is operating in quadrature phase mode (<code>SIGMODE=0</code>) and should be masked when <code>SIGMODE =1</code> .
				Value Description
				0 The <code>INTERROR</code> interrupt is suppressed and not sent to the interrupt controller.
				1 An interrupt is sent to the interrupt controller when the <code>INTERROR</code> bit in the QEIRIS register is set.
2	INTDIR	RW	0	Direction Change Interrupt Enable Value Description
				0 The <code>INTDIR</code> interrupt is suppressed and not sent to the interrupt controller.
				1 An interrupt is sent to the interrupt controller when the <code>INTDIR</code> bit in the QEIRIS register is set.
1	INTTIMER	RW	0	Timer Expires Interrupt Enable Value Description
				0 The <code>INTTIMER</code> interrupt is suppressed and not sent to the interrupt controller.
				1 An interrupt is sent to the interrupt controller when the <code>INTTIMER</code> bit in the QEIRIS register is set.

Bit/Field	Name	Type	Reset	Description
0	INTINDEX	RW	0	Index Pulse Detected Interrupt Enable
				Value Description
			0	The <code>INTINDEX</code> interrupt is suppressed and not sent to the interrupt controller.
			1	An interrupt is sent to the interrupt controller when the <code>INTINDEX</code> bit in the QEIRIS register is set.

Register 10: QEI Raw Interrupt Status (QEIRIS), offset 0x024

This register provides the current set of interrupt sources that are asserted, regardless of whether they cause an interrupt to be asserted to the controller (configured through the **QEIINTEN** register). If a bit is set, the latched event has occurred; if a bit is clear, the event in question has not occurred.

QEI Raw Interrupt Status (QEIRIS)

QEI0 base: 0x4002.C000

Offset 0x024

Type RO, reset 0x0000.0000

	31	30	29	28	27	26	25	24	23	22	21	20	19	18	17	16
	reserved															
Type	RO	RO	RO	RO	RO	RO	RO	RO	RO	RO	RO	RO	RO	RO	RO	RO
Reset	0	0	0	0	0	0	0	0	0	0	0	0	0	0	0	0
	15	14	13	12	11	10	9	8	7	6	5	4	3	2	1	0
	reserved												INTERROR	INTDIR	INTTIMER	INTINDEX
Type	RO	RO	RO	RO	RO	RO	RO	RO	RO	RO	RO	RO	RO	RO	RO	RO
Reset	0	0	0	0	0	0	0	0	0	0	0	0	0	0	0	0

Bit/Field	Name	Type	Reset	Description
31:4	reserved	RO	0x0000.000	Software should not rely on the value of a reserved bit. To provide compatibility with future products, the value of a reserved bit should be preserved across a read-modify-write operation.
3	INTERROR	RO	0	Phase Error Detected Note: The <code>INTERROR</code> bit is only applicable when the QEI is operating in quadrature phase mode (<code>SIGMODE=0</code>). Value Description 0 An interrupt has not occurred. 1 A phase error has been detected. This bit is cleared by writing a 1 to the <code>INTERROR</code> bit in the QEIISC register.
2	INTDIR	RO	0	Direction Change Detected Value Description 0 An interrupt has not occurred. 1 The rotation direction has changed This bit is cleared by writing a 1 to the <code>INTDIR</code> bit in the QEIISC register.
1	INTTIMER	RO	0	Velocity Timer Expired Value Description 0 An interrupt has not occurred. 1 The velocity timer has expired. This bit is cleared by writing a 1 to the <code>INTTIMER</code> bit in the QEIISC register.

Bit/Field	Name	Type	Reset	Description
0	INTINDEX	RO	0	Index Pulse Asserted
				Value Description
				0 An interrupt has not occurred.
				1 The index pulse has occurred.
				This bit is cleared by writing a 1 to the INTINDEX bit in the QEISC register.

Register 11: QEI Interrupt Status and Clear (QEIISC), offset 0x028

This register provides the current set of interrupt sources that are asserted to the controller. If a bit is set, the latched event has occurred and is enabled to generate an interrupt; if a bit is clear the event in question has not occurred or is not enabled to generate an interrupt. This register is RW1C; writing a 1 to a bit position clears the bit and the corresponding interrupt reason.

QEI Interrupt Status and Clear (QEIISC)

QEI0 base: 0x4002.C000

Offset 0x028

Type RW1C, reset 0x0000.0000

	31	30	29	28	27	26	25	24	23	22	21	20	19	18	17	16	
	reserved																
Type	RO	RO	RO	RO	RO	RO	RO	RO	RO	RO	RO	RO	RO	RO	RO	RO	
Reset	0	0	0	0	0	0	0	0	0	0	0	0	0	0	0	0	
	15	14	13	12	11	10	9	8	7	6	5	4	3	2	1	0	
	reserved												INTERROR	INTDIR	INTTIMER	INTINDEX	
Type	RO	RO	RO	RO	RO	RO	RO	RO	RO	RO	RO	RO	RO	RW1C	RW1C	RW1C	RW1C
Reset	0	0	0	0	0	0	0	0	0	0	0	0	0	0	0	0	0

Bit/Field	Name	Type	Reset	Description
31:4	reserved	RO	0x0000.000	Software should not rely on the value of a reserved bit. To provide compatibility with future products, the value of a reserved bit should be preserved across a read-modify-write operation.
3	INTERROR	RW1C	0	Phase Error Interrupt Value Description 0 No interrupt has occurred or the interrupt is masked. 1 The INTERROR bits in the QEIRIS register and the QEINTEN registers are set, providing an interrupt to the interrupt controller. This bit is cleared by writing a 1. Clearing this bit also clears the INTERROR bit in the QEIRIS register.
2	INTDIR	RW1C	0	Direction Change Interrupt Value Description 0 No interrupt has occurred or the interrupt is masked. 1 The INTDIR bits in the QEIRIS register and the QEINTEN registers are set, providing an interrupt to the interrupt controller. This bit is cleared by writing a 1. Clearing this bit also clears the INTDIR bit in the QEIRIS register.
1	INTTIMER	RW1C	0	Velocity Timer Expired Interrupt Value Description 0 No interrupt has occurred or the interrupt is masked. 1 The INTTIMER bits in the QEIRIS register and the QEINTEN registers are set, providing an interrupt to the interrupt controller. This bit is cleared by writing a 1. Clearing this bit also clears the INTTIMER bit in the QEIRIS register.

Bit/Field	Name	Type	Reset	Description
0	INTINDEX	RW1C	0	Index Pulse Interrupt
				Value Description
				0 No interrupt has occurred or the interrupt is masked.
				1 The INTINDEX bits in the QEIRIS register and the QEINTEN registers are set, providing an interrupt to the interrupt controller.
				This bit is cleared by writing a 1. Clearing this bit also clears the INTINDEX bit in the QEIRIS register.

28 Pin Diagram

The TM4C129ENCPDT microcontroller pin diagram is shown below.

Each GPIO signal is identified by its GPIO port unless it defaults to an alternate function on reset. In this case, the GPIO port name is followed by the default alternate function. To see a complete list of possible functions for each pin, see Table 29-5 on page 1932.

Figure 28-1. 128-Pin TQFP Package Pin Diagram

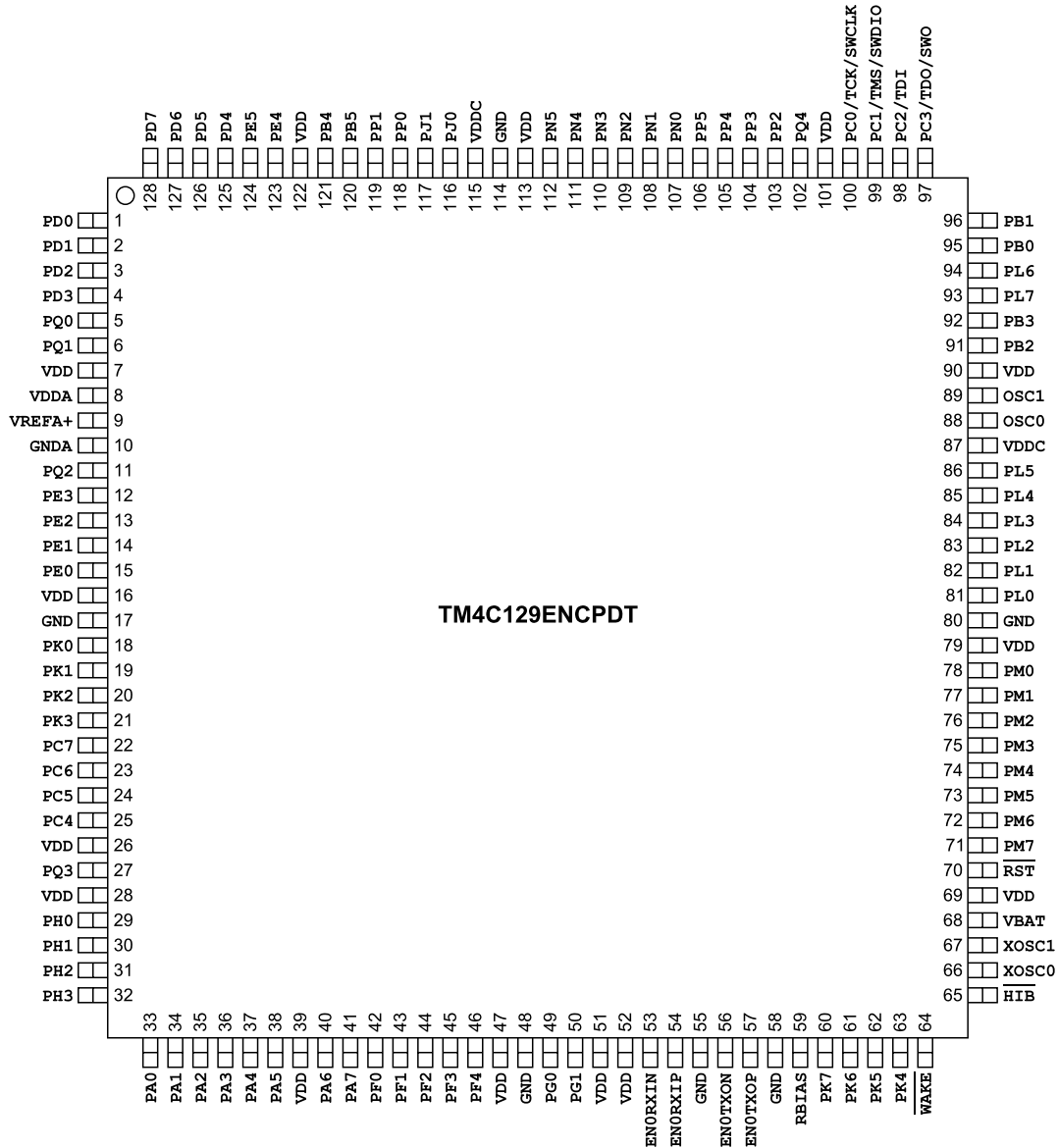

29 Signal Tables

The following tables list the signals available for each pin. Signals are configured as GPIOs on reset, except for those noted below. Use the **GPIOAMSEL** register (see page 794) to select analog mode. For a GPIO pin to be used for an alternate digital function, the corresponding bit in the **GPIOAFSEL** register (see page 778) must be set. Further pin muxing options are provided through the PMC_x bit field in the **GPIOPCTL** register (see page 795), which selects one of several available peripheral functions for that GPIO.

Important: Table 10-1 on page 751 shows special consideration GPIO pins. Most GPIO pins are configured as GPIOs and tri-stated by default (**GPIOAFSEL**=0, **GIODEN**=0, **GPIOPDR**=0, **GPIOPUR**=0, and **GPIOPCTL**=0). Special consideration pins may be programmed to a non-GPIO function or may have special commit controls out of reset. In addition, a Power-On-Reset (\overline{POR}) returns these GPIO to their original special consideration state.

Table 29-1. GPIO Pins With Special Considerations

GPIO Pins	Default Reset State	GPIOAFSEL	GIODEN	GPIOPDR	GPIOPUR	GPIOPCTL	GPIOCR
PC[3:0]	JTAG/SWD	1	1	0	1	0x1	0
PD[7]	GPIO ^a	0	0	0	0	0x0	0
PE[7]	GPIO ^a	0	0	0	0	0x0	0

a. This pin is configured as a GPIO by default but is locked and can only be reprogrammed by unlocking the pin in the **GPIOLOCK** register and uncommitting it by setting the **GPIOCR** register.

Table 29-2 on page 1897 shows the pin-to-signal-name mapping, including functional characteristics of the signals. Each possible alternate analog and digital function is listed for each pin.

Table 29-3 on page 1909 lists the signals in alphabetical order by signal name. If it is possible for a signal to be on multiple pins, each possible pin assignment is listed. The "Pin Mux" column indicates the GPIO and the encoding needed in the PMC_x bit field in the **GPIOPCTL** register.

Table 29-4 on page 1921 groups the signals by functionality, except for GPIOs. If it is possible for a signal to be on multiple pins, each possible pin assignment is listed.

Table 29-5 on page 1932 lists the GPIO pins and their analog and digital alternate functions. The A_{INx} analog signals go through an isolation circuit before reaching their circuitry. These signals are configured by clearing the corresponding **DEN** bit in the **GPIO Digital Enable (GIODEN)** register and setting the corresponding **AMSEL** bit in the **GPIO Analog Mode Select (GPIOAMSEL)** register. Other analog signals are 3.3-V tolerant and are connected directly to their circuitry ($C0-$, $C0+$, $C1-$, $C1+$, $C2-$, $C2+$, $USB0VBUS$, $USB0ID$). These signals are configured by clearing the **DEN** bit in the **GPIO Digital Enable (GIODEN)** register. The digital signals are enabled by setting the appropriate bit in the **GPIO Alternate Function Select (GPIOAFSEL)** and **GIODEN** registers and configuring the PMC_x bit field in the **GPIO Port Control (GPIOPCTL)** register to the numeric encoding shown in the table below. Table entries that are shaded gray are the default values for the corresponding GPIO pin.

Table 29-6 on page 1935 lists the signals based on number of possible pin assignments. This table can be used to plan how to configure the pins for a particular functionality. Application Note AN01274 Configuring Tiva™ C Series Microcontrollers with Pin Multiplexing provides an overview of the pin muxing implementation, an explanation of how a system designer defines a pin configuration, and examples of the pin configuration process.

Note: All digital inputs are Schmitt triggered.

29.1 Signals by Pin Number

Table 29-2. Signals by Pin Number

Pin Number	Pin Name	Pin Type	Buffer Type	Description
1	PD0	I/O	TTL	GPIO port D bit 0.
	AIN15	I	Analog	Analog-to-digital converter input 15.
	C0o	O	TTL	Analog comparator 0 output.
	I2C7SCL	I/O	OD	I ² C module 7 clock. Note that this signal has an active pull-up. The corresponding port pin should not be configured as open drain.
	SSI2XDAT1	I/O	TTL	SSI Module 2 Bi-directional Data Pin 1 (SSI2RX in Legacy SSI Mode).
	T0CCP0	I/O	TTL	16/32-Bit Timer 0 Capture/Compare/PWM 0.
2	PD1	I/O	TTL	GPIO port D bit 1.
	AIN14	I	Analog	Analog-to-digital converter input 14.
	C1o	O	TTL	Analog comparator 1 output.
	I2C7SDA	I/O	OD	I ² C module 7 data.
	SSI2XDAT0	I/O	TTL	SSI Module 2 Bi-directional Data Pin 0 (SSI2TX in Legacy SSI Mode).
	T0CCP1	I/O	TTL	16/32-Bit Timer 0 Capture/Compare/PWM 1.
3	PD2	I/O	TTL	GPIO port D bit 2.
	AIN13	I	Analog	Analog-to-digital converter input 13.
	C2o	O	TTL	Analog comparator 2 output.
	I2C8SCL	I/O	OD	I ² C module 8 clock. Note that this signal has an active pull-up. The corresponding port pin should not be configured as open drain.
	SSI2Fss	I/O	TTL	SSI module 2 frame signal.
	T1CCP0	I/O	TTL	16/32-Bit Timer 1 Capture/Compare/PWM 0.
4	PD3	I/O	TTL	GPIO port D bit 3.
	AIN12	I	Analog	Analog-to-digital converter input 12.
	I2C8SDA	I/O	OD	I ² C module 8 data.
	SSI2C1k	I/O	TTL	SSI module 2 clock.
	T1CCP1	I/O	TTL	16/32-Bit Timer 1 Capture/Compare/PWM 1.
5	PQ0	I/O	TTL	GPIO port Q bit 0.
	EPI0S20	I/O	TTL	EPI module 0 signal 20.
	SSI3C1k	I/O	TTL	SSI module 3 clock.
6	PQ1	I/O	TTL	GPIO port Q bit 1.
	EPI0S21	I/O	TTL	EPI module 0 signal 21.
	SSI3Fss	I/O	TTL	SSI module 3 frame signal.
7	VDD	-	Power	Positive supply for I/O and some logic.
8	VDDA	-	Power	The positive supply for the analog circuits (ADC, Analog Comparators, etc.). These are separated from VDD to minimize the electrical noise contained on VDD from affecting the analog functions. VDDA pins must be supplied with a voltage that meets the specification in , regardless of system implementation.

Table 29-2. Signals by Pin Number (continued)

Pin Number	Pin Name	Pin Type	Buffer Type	Description
9	VREFA+	-	Analog	A reference voltage used to specify the voltage at which the ADC converts to a maximum value. This pin is used in conjunction with GNDA. The voltage that is applied to VREFA+ is the voltage with which an AIN _n signal is converted to 4095. The VREFA+ voltage is limited to the range specified in Table 30-44 on page 1985.
10	GNDA	-	Power	The ground reference for the analog circuits (ADC, Analog Comparators, etc.). These are separated from GND to minimize the electrical noise contained on VDD from affecting the analog functions.
11	PQ2	I/O	TTL	GPIO port Q bit 2.
	EPI0S22	I/O	TTL	EPI module 0 signal 22.
	SSI3XDAT0	I/O	TTL	SSI Module 3 Bi-directional Data Pin 0 (SSI3TX in Legacy SSI Mode).
12	PE3	I/O	TTL	GPIO port E bit 3.
	AIN0	I	Analog	Analog-to-digital converter input 0.
	U1DTR	O	TTL	UART module 1 Data Terminal Ready modem status input signal.
13	PE2	I/O	TTL	GPIO port E bit 2.
	AIN1	I	Analog	Analog-to-digital converter input 1.
	U1DCD	I	TTL	UART module 1 Data Carrier Detect modem status input signal.
14	PE1	I/O	TTL	GPIO port E bit 1.
	AIN2	I	Analog	Analog-to-digital converter input 2.
	U1DSR	I	TTL	UART module 1 Data Set Ready modem output control line.
15	PE0	I/O	TTL	GPIO port E bit 0.
	AIN3	I	Analog	Analog-to-digital converter input 3.
	U1RTS	O	TTL	UART module 1 Request to Send modem flow control output line.
16	VDD	-	Power	Positive supply for I/O and some logic.
17	GND	-	Power	Ground reference for logic and I/O pins.
18	PK0	I/O	TTL	GPIO port K bit 0.
	AIN16	I	Analog	Analog-to-digital converter input 16.
	EPI0S0	I/O	TTL	EPI module 0 signal 0.
	U4Rx	I	TTL	UART module 4 receive.
19	PK1	I/O	TTL	GPIO port K bit 1.
	AIN17	I	Analog	Analog-to-digital converter input 17.
	EPI0S1	I/O	TTL	EPI module 0 signal 1.
	U4Tx	O	TTL	UART module 4 transmit.
20	PK2	I/O	TTL	GPIO port K bit 2.
	AIN18	I	Analog	Analog-to-digital converter input 18.
	EPI0S2	I/O	TTL	EPI module 0 signal 2.
	U4RTS	O	TTL	UART module 4 Request to Send modem flow control output line.
21	PK3	I/O	TTL	GPIO port K bit 3.
	AIN19	I	Analog	Analog-to-digital converter input 19.
	EPI0S3	I/O	TTL	EPI module 0 signal 3.
	U4CTS	I	TTL	UART module 4 Clear To Send modem flow control input signal.

Table 29-2. Signals by Pin Number (continued)

Pin Number	Pin Name	Pin Type	Buffer Type	Description
22	PC7	I/O	TTL	GPIO port C bit 7.
	C0-	I	Analog	Analog comparator 0 negative input.
	EPI0S4	I/O	TTL	EPI module 0 signal 4.
	U5Tx	O	TTL	UART module 5 transmit.
23	PC6	I/O	TTL	GPIO port C bit 6.
	C0+	I	Analog	Analog comparator 0 positive input.
	EPI0S5	I/O	TTL	EPI module 0 signal 5.
	U5Rx	I	TTL	UART module 5 receive.
24	PC5	I/O	TTL	GPIO port C bit 5.
	C1+	I	Analog	Analog comparator 1 positive input.
	EPI0S6	I/O	TTL	EPI module 0 signal 6.
	RTCCLK	O	TTL	Buffered version of the Hibernation module's 32.768-kHz clock. This signal is not output when the part is in Hibernate mode and before being configured after power-on reset.
	U7Tx	O	TTL	UART module 7 transmit.
25	PC4	I/O	TTL	GPIO port C bit 4.
	C1-	I	Analog	Analog comparator 1 negative input.
	EPI0S7	I/O	TTL	EPI module 0 signal 7.
	U7Rx	I	TTL	UART module 7 receive.
26	VDD	-	Power	Positive supply for I/O and some logic.
27	PQ3	I/O	TTL	GPIO port Q bit 3.
	EPI0S23	I/O	TTL	EPI module 0 signal 23.
	SSI3XDAT1	I/O	TTL	SSI Module 3 Bi-directional Data Pin 1 (SSI3RX in Legacy SSI Mode).
28	VDD	-	Power	Positive supply for I/O and some logic.
29	PH0	I/O	TTL	GPIO port H bit 0.
	EPI0S0	I/O	TTL	EPI module 0 signal 0.
	U0RTS	O	TTL	UART module 0 Request to Send modem flow control output signal.
30	PH1	I/O	TTL	GPIO port H bit 1.
	EPI0S1	I/O	TTL	EPI module 0 signal 1.
	U0CTS	I	TTL	UART module 0 Clear To Send modem flow control input signal.
31	PH2	I/O	TTL	GPIO port H bit 2.
	EPI0S2	I/O	TTL	EPI module 0 signal 2.
	U0DCD	I	TTL	UART module 0 Data Carrier Detect modem status input signal.
32	PH3	I/O	TTL	GPIO port H bit 3.
	EPI0S3	I/O	TTL	EPI module 0 signal 3.
	U0DSR	I	TTL	UART module 0 Data Set Ready modem output control line.

Table 29-2. Signals by Pin Number (continued)

Pin Number	Pin Name	Pin Type	Buffer Type	Description
33	PA0	I/O	TTL	GPIO port A bit 0.
	CAN0Rx	I	TTL	CAN module 0 receive.
	I2C9SCL	I/O	OD	I ² C module 9 clock. Note that this signal has an active pull-up. The corresponding port pin should not be configured as open drain.
	T0CCP0	I/O	TTL	16/32-Bit Timer 0 Capture/Compare/PWM 0.
	U0Rx	I	TTL	UART module 0 receive.
34	PA1	I/O	TTL	GPIO port A bit 1.
	CAN0Tx	O	TTL	CAN module 0 transmit.
	I2C9SDA	I/O	OD	I ² C module 9 data.
	T0CCP1	I/O	TTL	16/32-Bit Timer 0 Capture/Compare/PWM 1.
	U0Tx	O	TTL	UART module 0 transmit.
35	PA2	I/O	TTL	GPIO port A bit 2.
	I2C8SCL	I/O	OD	I ² C module 8 clock. Note that this signal has an active pull-up. The corresponding port pin should not be configured as open drain.
	SSI0Clk	I/O	TTL	SSI module 0 clock
	T1CCP0	I/O	TTL	16/32-Bit Timer 1 Capture/Compare/PWM 0.
	U4Rx	I	TTL	UART module 4 receive.
36	PA3	I/O	TTL	GPIO port A bit 3.
	I2C8SDA	I/O	OD	I ² C module 8 data.
	SSI0Fss	I/O	TTL	SSI module 0 frame signal
	T1CCP1	I/O	TTL	16/32-Bit Timer 1 Capture/Compare/PWM 1.
	U4Tx	O	TTL	UART module 4 transmit.
37	PA4	I/O	TTL	GPIO port A bit 4.
	I2C7SCL	I/O	OD	I ² C module 7 clock. Note that this signal has an active pull-up. The corresponding port pin should not be configured as open drain.
	SSI0XDAT0	I/O	TTL	SSI Module 0 Bi-directional Data Pin 0 (SSI0TX in Legacy SSI Mode).
	T2CCP0	I/O	TTL	16/32-Bit Timer 2 Capture/Compare/PWM 0.
	U3Rx	I	TTL	UART module 3 receive.
38	PA5	I/O	TTL	GPIO port A bit 5.
	I2C7SDA	I/O	OD	I ² C module 7 data.
	SSI0XDAT1	I/O	TTL	SSI Module 0 Bi-directional Data Pin 1 (SSI0RX in Legacy SSI Mode).
	T2CCP1	I/O	TTL	16/32-Bit Timer 2 Capture/Compare/PWM 1.
	U3Tx	O	TTL	UART module 3 transmit.
39	VDD	-	Power	Positive supply for I/O and some logic.

Table 29-2. Signals by Pin Number (continued)

Pin Number	Pin Name	Pin Type	Buffer Type	Description
40	PA6	I/O	TTL	GPIO port A bit 6.
	EPI0S8	I/O	TTL	EPI module 0 signal 8.
	I2C6SCL	I/O	OD	I ² C module 6 clock. Note that this signal has an active pull-up. The corresponding port pin should not be configured as open drain.
	SSI0XDAT2	I/O	TTL	SSI Module 0 Bi-directional Data Pin 2.
	T3CCP0	I/O	TTL	16/32-Bit Timer 3 Capture/Compare/PWM 0.
	U2Rx	I	TTL	UART module 2 receive.
	USB0EPEN	O	TTL	Optionally used in Host mode to control an external power source to supply power to the USB bus.
41	PA7	I/O	TTL	GPIO port A bit 7.
	EPI0S9	I/O	TTL	EPI module 0 signal 9.
	I2C6SDA	I/O	OD	I ² C module 6 data.
	SSI0XDAT3	I/O	TTL	SSI Module 0 Bi-directional Data Pin 3.
	T3CCP1	I/O	TTL	16/32-Bit Timer 3 Capture/Compare/PWM 1.
	U2Tx	O	TTL	UART module 2 transmit.
	USB0EPEN	O	TTL	Optionally used in Host mode to control an external power source to supply power to the USB bus.
USB0PFLT	I	TTL	Optionally used in Host mode by an external power source to indicate an error state by that power source.	
42	PF0	I/O	TTL	GPIO port F bit 0.
	EN0LED0	O	TTL	Ethernet 0 LED 0.
	M0PWM0	O	TTL	Motion Control Module 0 PWM 0. This signal is controlled by Module 0 PWM Generator 0.
	SSI3XDAT1	I/O	TTL	SSI Module 3 Bi-directional Data Pin 1 (SSI3RX in Legacy SSI Mode).
	TRD2	O	TTL	Trace data 2.
43	PF1	I/O	TTL	GPIO port F bit 1.
	EN0LED2	O	TTL	Ethernet 0 LED 2.
	M0PWM1	O	TTL	Motion Control Module 0 PWM 1. This signal is controlled by Module 0 PWM Generator 0.
	SSI3XDAT0	I/O	TTL	SSI Module 3 Bi-directional Data Pin 0 (SSI3TX in Legacy SSI Mode).
	TRD1	O	TTL	Trace data 1.
44	PF2	I/O	TTL	GPIO port F bit 2.
	M0PWM2	O	TTL	Motion Control Module 0 PWM 2. This signal is controlled by Module 0 PWM Generator 1.
	SSI3Fss	I/O	TTL	SSI module 3 frame signal.
	TRD0	O	TTL	Trace data 0.
45	PF3	I/O	TTL	GPIO port F bit 3.
	M0PWM3	O	TTL	Motion Control Module 0 PWM 3. This signal is controlled by Module 0 PWM Generator 1.
	SSI3Clk	I/O	TTL	SSI module 3 clock.
	TRCLK	O	TTL	Trace clock.

Table 29-2. Signals by Pin Number (continued)

Pin Number	Pin Name	Pin Type	Buffer Type	Description
46	PF4	I/O	TTL	GPIO port F bit 4.
	EN0LED1	O	TTL	Ethernet 0 LED 1.
	M0FAULT0	I	TTL	Motion Control Module 0 PWM Fault 0.
	SSI3XDAT2	I/O	TTL	SSI Module 3 Bi-directional Data Pin 2.
	TRD3	O	TTL	Trace data 3.
47	VDD	-	Power	Positive supply for I/O and some logic.
48	GND	-	Power	Ground reference for logic and I/O pins.
49	PG0	I/O	TTL	GPIO port G bit 0.
	EN0PPS	O	TTL	Ethernet 0 Pulse-Per-Second (PPS) Output.
	EPI0S11	I/O	TTL	EPI module 0 signal 11.
	I2C1SCL	I/O	OD	I ² C module 1 clock. Note that this signal has an active pull-up. The corresponding port pin should not be configured as open drain.
	M0PWM4	O	TTL	Motion Control Module 0 PWM 4. This signal is controlled by Module 0 PWM Generator 2.
50	PG1	I/O	TTL	GPIO port G bit 1.
	EPI0S10	I/O	TTL	EPI module 0 signal 10.
	I2C1SDA	I/O	OD	I ² C module 1 data.
	M0PWM5	O	TTL	Motion Control Module 0 PWM 5. This signal is controlled by Module 0 PWM Generator 2.
51	VDD	-	Power	Positive supply for I/O and some logic.
52	VDD	-	Power	Positive supply for I/O and some logic.
53	EN0RXIN	I/O	TTL	Ethernet PHY negative receive differential input.
54	EN0RXIP	I/O	TTL	Ethernet PHY positive receive differential input.
55	GND	-	Power	Ground reference for logic and I/O pins.
56	EN0TXON	I/O	TTL	Ethernet PHY negative transmit differential output.
57	EN0TXOP	I/O	TTL	Ethernet PHY positive transmit differential output.
58	GND	-	Power	Ground reference for logic and I/O pins.
59	RBIAS	O	Analog	4.87-k Ω resistor (1% precision) for Ethernet PHY.
60	PK7	I/O	TTL	GPIO port K bit 7.
	EPI0S24	I/O	TTL	EPI module 0 signal 24.
	I2C4SDA	I/O	OD	I ² C module 4 data.
	M0FAULT2	I	TTL	Motion Control Module 0 PWM Fault 2.
	RTCCLK	O	TTL	Buffered version of the Hibernation module's 32.768-kHz clock. This signal is not output when the part is in Hibernate mode and before being configured after power-on reset.
	U0RI	I	TTL	UART module 0 Ring Indicator modem status input signal.
61	PK6	I/O	TTL	GPIO port K bit 6.
	EN0LED1	O	TTL	Ethernet 0 LED 1.
	EPI0S25	I/O	TTL	EPI module 0 signal 25.
	I2C4SCL	I/O	OD	I ² C module 4 clock. Note that this signal has an active pull-up. The corresponding port pin should not be configured as open drain.
	M0FAULT1	I	TTL	Motion Control Module 0 PWM Fault 1.

Table 29-2. Signals by Pin Number (continued)

Pin Number	Pin Name	Pin Type	Buffer Type	Description
62	PK5	I/O	TTL	GPIO port K bit 5.
	EN0LED2	O	TTL	Ethernet 0 LED 2.
	EPI0S31	I/O	TTL	EPI module 0 signal 31.
	I2C3SDA	I/O	OD	I ² C module 3 data.
	M0PWM7	O	TTL	Motion Control Module 0 PWM 7. This signal is controlled by Module 0 PWM Generator 3.
63	PK4	I/O	TTL	GPIO port K bit 4.
	EN0LED0	O	TTL	Ethernet 0 LED 0.
	EPI0S32	I/O	TTL	EPI module 0 signal 32.
	I2C3SCL	I/O	OD	I ² C module 3 clock. Note that this signal has an active pull-up. The corresponding port pin should not be configured as open drain.
	M0PWM6	O	TTL	Motion Control Module 0 PWM 6. This signal is controlled by Module 0 PWM Generator 3.
64	$\overline{\text{WAKE}}$	I	TTL	An external input that brings the processor out of Hibernate mode when asserted.
65	$\overline{\text{HIB}}$	O	TTL	An output that indicates the processor is in Hibernate mode.
66	XOSC0	I	Analog	Hibernation module oscillator crystal input or an external clock reference input. Note that this is either a crystal or a 32.768-kHz oscillator for the Hibernation module RTC.
67	XOSC1	O	Analog	Hibernation module oscillator crystal output. Leave unconnected when using a single-ended clock source.
68	VBAT	-	Power	Power source for the Hibernation module. It is normally connected to the positive terminal of a battery and serves as the battery backup/Hibernation module power-source supply.
69	VDD	-	Power	Positive supply for I/O and some logic.
70	$\overline{\text{RST}}$	I	TTL	System reset input.
71	PM7	I/O	TTL	GPIO port M bit 7.
	T5CCP1	I/O	TTL	16/32-Bit Timer 5 Capture/Compare/PWM 1.
	TMPR0	I/O	TTL	Tamper signal 0.
	U0RI	I	TTL	UART module 0 Ring Indicator modem status input signal.
72	PM6	I/O	TTL	GPIO port M bit 6.
	T5CCP0	I/O	TTL	16/32-Bit Timer 5 Capture/Compare/PWM 0.
	TMPR1	I/O	TTL	Tamper signal 1.
	U0DSR	I	TTL	UART module 0 Data Set Ready modem output control line.
73	PM5	I/O	TTL	GPIO port M bit 5.
	T4CCP1	I/O	TTL	16/32-Bit Timer 4 Capture/Compare/PWM 1.
	TMPR2	I/O	TTL	Tamper signal 2.
	U0DCD	I	TTL	UART module 0 Data Carrier Detect modem status input signal.
74	PM4	I/O	TTL	GPIO port M bit 4.
	T4CCP0	I/O	TTL	16/32-Bit Timer 4 Capture/Compare/PWM 0.
	TMPR3	I/O	TTL	Tamper signal 3.
	U0CTS	I	TTL	UART module 0 Clear To Send modem flow control input signal.

Table 29-2. Signals by Pin Number (continued)

Pin Number	Pin Name	Pin Type	Buffer Type	Description
75	PM3	I/O	TTL	GPIO port M bit 3.
	EPI0S12	I/O	TTL	EPI module 0 signal 12.
	T3CCP1	I/O	TTL	16/32-Bit Timer 3 Capture/Compare/PWM 1.
76	PM2	I/O	TTL	GPIO port M bit 2.
	EPI0S13	I/O	TTL	EPI module 0 signal 13.
	T3CCP0	I/O	TTL	16/32-Bit Timer 3 Capture/Compare/PWM 0.
77	PM1	I/O	TTL	GPIO port M bit 1.
	EPI0S14	I/O	TTL	EPI module 0 signal 14.
	T2CCP1	I/O	TTL	16/32-Bit Timer 2 Capture/Compare/PWM 1.
78	PM0	I/O	TTL	GPIO port M bit 0.
	EPI0S15	I/O	TTL	EPI module 0 signal 15.
	T2CCP0	I/O	TTL	16/32-Bit Timer 2 Capture/Compare/PWM 0.
79	VDD	-	Power	Positive supply for I/O and some logic.
80	GND	-	Power	Ground reference for logic and I/O pins.
81	PL0	I/O	TTL	GPIO port L bit 0.
	EPI0S16	I/O	TTL	EPI module 0 signal 16.
	I2C2SDA	I/O	OD	I ² C module 2 data.
	M0FAULT3	I	TTL	Motion Control Module 0 PWM Fault 3.
	USB0D0	I/O	TTL	USB data 0.
82	PL1	I/O	TTL	GPIO port L bit 1.
	EPI0S17	I/O	TTL	EPI module 0 signal 17.
	I2C2SCL	I/O	OD	I ² C module 2 clock. Note that this signal has an active pull-up. The corresponding port pin should not be configured as open drain.
	PhA0	I	TTL	QEI module 0 phase A.
	USB0D1	I/O	TTL	USB data 1.
83	PL2	I/O	TTL	GPIO port L bit 2.
	C0o	O	TTL	Analog comparator 0 output.
	EPI0S18	I/O	TTL	EPI module 0 signal 18.
	PhB0	I	TTL	QEI module 0 phase B.
	USB0D2	I/O	TTL	USB data 2.
84	PL3	I/O	TTL	GPIO port L bit 3.
	C1o	O	TTL	Analog comparator 1 output.
	EPI0S19	I/O	TTL	EPI module 0 signal 19.
	IDX0	I	TTL	QEI module 0 index.
	USB0D3	I/O	TTL	USB data 3.
85	PL4	I/O	TTL	GPIO port L bit 4.
	EPI0S26	I/O	TTL	EPI module 0 signal 26.
	T0CCP0	I/O	TTL	16/32-Bit Timer 0 Capture/Compare/PWM 0.
	USB0D4	I/O	TTL	USB data 4.

Table 29-2. Signals by Pin Number (continued)

Pin Number	Pin Name	Pin Type	Buffer Type	Description
86	PL5	I/O	TTL	GPIO port L bit 5.
	EPI0S33	I/O	TTL	EPI module 0 signal 33.
	T0CCP1	I/O	TTL	16/32-Bit Timer 0 Capture/Compare/PWM 1.
	USB0D5	I/O	TTL	USB data 5.
87	VDDC	-	Power	Positive supply for most of the logic function, including the processor core and most peripherals. The voltage on this pin is 1.2 V and is supplied by the on-chip LDO. The VDDC pins should only be connected to each other and an external capacitor as specified in Table 30-15 on page 1958 .
88	OSC0	I	Analog	Main oscillator crystal input or an external clock reference input.
89	OSC1	O	Analog	Main oscillator crystal output. Leave unconnected when using a single-ended clock source.
90	VDD	-	Power	Positive supply for I/O and some logic.
91	PB2	I/O	TTL	GPIO port B bit 2.
	EPI0S27	I/O	TTL	EPI module 0 signal 27.
	I2C0SCL	I/O	OD	I ² C module 0 clock. Note that this signal has an active pull-up. The corresponding port pin should not be configured as open drain.
	T5CCP0	I/O	TTL	16/32-Bit Timer 5 Capture/Compare/PWM 0.
	USB0STP	O	TTL	Asserted by the USB controller to signal the end of a USB transmit packet or register write operation.
92	PB3	I/O	TTL	GPIO port B bit 3.
	EPI0S28	I/O	TTL	EPI module 0 signal 28.
	I2C0SDA	I/O	OD	I ² C module 0 data.
	T5CCP1	I/O	TTL	16/32-Bit Timer 5 Capture/Compare/PWM 1.
	USB0CLK	O	TTL	60-MHz clock to the external PHY.
93	PL7	I/O	TTL	GPIO port L bit 7.
	T1CCP1	I/O	TTL	16/32-Bit Timer 1 Capture/Compare/PWM 1.
	USB0DM	I/O	Analog	Bidirectional differential data pin (D- per USB specification) for USB0.
94	PL6	I/O	TTL	GPIO port L bit 6.
	T1CCP0	I/O	TTL	16/32-Bit Timer 1 Capture/Compare/PWM 0.
	USB0DP	I/O	Analog	Bidirectional differential data pin (D+ per USB specification) for USB0.
95	PB0	I/O	TTL	GPIO port B bit 0.
	CAN1Rx	I	TTL	CAN module 1 receive.
	I2C5SCL	I/O	OD	I ² C module 5 clock. Note that this signal has an active pull-up. The corresponding port pin should not be configured as open drain.
	T4CCP0	I/O	TTL	16/32-Bit Timer 4 Capture/Compare/PWM 0.
	U1Rx	I	TTL	UART module 1 receive.
	USB0ID	I	Analog	This signal senses the state of the USB ID signal. The USB PHY enables an integrated pull-up, and an external element (USB connector) indicates the initial state of the USB controller (pulled down is the A side of the cable and pulled up is the B side).

Table 29-2. Signals by Pin Number (continued)

Pin Number	Pin Name	Pin Type	Buffer Type	Description
96	PB1	I/O	TTL	GPIO port B bit 1.
	CAN1Tx	O	TTL	CAN module 1 transmit.
	I2C5SDA	I/O	OD	I ² C module 5 data.
	T4CCP1	I/O	TTL	16/32-Bit Timer 4 Capture/Compare/PWM 1.
	U1Tx	O	TTL	UART module 1 transmit.
	USB0VBUS	I/O	Analog	This signal is used during the session request protocol. This signal allows the USB PHY to both sense the voltage level of VBUS, and pull up VBUS momentarily during VBUS pulsing.
97	PC3	I/O	TTL	GPIO port C bit 3.
	SWO	O	TTL	JTAG TDO and SWO.
	TDO	O	TTL	JTAG TDO and SWO.
98	PC2	I/O	TTL	GPIO port C bit 2.
	TDI	I	TTL	JTAG TDI.
99	PC1	I/O	TTL	GPIO port C bit 1.
	SWDIO	I/O	TTL	JTAG TMS and SWDIO.
	TMS	I	TTL	JTAG TMS and SWDIO.
100	PC0	I/O	TTL	GPIO port C bit 0.
	SWCLK	I	TTL	JTAG/SWD CLK.
	TCK	I	TTL	JTAG/SWD CLK.
101	VDD	-	Power	Positive supply for I/O and some logic.
102	PQ4	I/O	TTL	GPIO port Q bit 4.
	DIVSCLK	O	TTL	An optionally divided reference clock output based on a selected clock source. Note that this signal is not synchronized to the System Clock.
	U1Rx	I	TTL	UART module 1 receive.
103	PP2	I/O	TTL	GPIO port P bit 2.
	EPI0S29	I/O	TTL	EPI module 0 signal 29.
	U0DTR	O	TTL	UART module 0 Data Terminal Ready modem status input signal.
	USB0NXT	O	TTL	Asserted by the external PHY to throttle all data types.
104	PP3	I/O	TTL	GPIO port P bit 3.
	EPI0S30	I/O	TTL	EPI module 0 signal 30.
	RTCCLK	O	TTL	Buffered version of the Hibernation module's 32.768-kHz clock. This signal is not output when the part is in Hibernate mode and before being configured after power-on reset.
	U0DCD	I	TTL	UART module 0 Data Carrier Detect modem status input signal.
	U1CTS	I	TTL	UART module 1 Clear To Send modem flow control input signal.
	USB0DIR	O	TTL	Indicates that the external PHY is able to accept data from the USB controller.
105	PP4	I/O	TTL	GPIO port P bit 4.
	U0DSR	I	TTL	UART module 0 Data Set Ready modem output control line.
	U3RTS	O	TTL	UART module 3 Request to Send modem flow control output line.
	USB0D7	I/O	TTL	USB data 7.

Table 29-2. Signals by Pin Number (continued)

Pin Number	Pin Name	Pin Type	Buffer Type	Description
106	PP5	I/O	TTL	GPIO port P bit 5.
	I2C2SCL	I/O	OD	I ² C module 2 clock. Note that this signal has an active pull-up. The corresponding port pin should not be configured as open drain.
	U3CTS	I	TTL	UART module 3 Clear To Send modem flow control input signal.
	USB0D6	I/O	TTL	USB data 6.
107	PN0	I/O	TTL	GPIO port N bit 0.
	U1RTS	O	TTL	UART module 1 Request to Send modem flow control output line.
108	PN1	I/O	TTL	GPIO port N bit 1.
	U1CTS	I	TTL	UART module 1 Clear To Send modem flow control input signal.
109	PN2	I/O	TTL	GPIO port N bit 2.
	EPI0S29	I/O	TTL	EPI module 0 signal 29.
	U1DCD	I	TTL	UART module 1 Data Carrier Detect modem status input signal.
	U2RTS	O	TTL	UART module 2 Request to Send modem flow control output line.
110	PN3	I/O	TTL	GPIO port N bit 3.
	EPI0S30	I/O	TTL	EPI module 0 signal 30.
	U1DSR	I	TTL	UART module 1 Data Set Ready modem output control line.
	U2CTS	I	TTL	UART module 2 Clear To Send modem flow control input signal.
111	PN4	I/O	TTL	GPIO port N bit 4.
	EPI0S34	I/O	TTL	EPI module 0 signal 34.
	I2C2SDA	I/O	OD	I ² C module 2 data.
	U1DTR	O	TTL	UART module 1 Data Terminal Ready modem status input signal.
	U3RTS	O	TTL	UART module 3 Request to Send modem flow control output line.
112	PN5	I/O	TTL	GPIO port N bit 5.
	EPI0S35	I/O	TTL	EPI module 0 signal 35.
	I2C2SCL	I/O	OD	I ² C module 2 clock. Note that this signal has an active pull-up. The corresponding port pin should not be configured as open drain.
	U1RI	I	TTL	UART module 1 Ring Indicator modem status input signal.
	U3CTS	I	TTL	UART module 3 Clear To Send modem flow control input signal.
113	VDD	-	Power	Positive supply for I/O and some logic.
114	GND	-	Power	Ground reference for logic and I/O pins.
115	VDDC	-	Power	Positive supply for most of the logic function, including the processor core and most peripherals. The voltage on this pin is 1.2 V and is supplied by the on-chip LDO. The VDDC pins should only be connected to each other and an external capacitor as specified in Table 30-15 on page 1958 .
116	PJ0	I/O	TTL	GPIO port J bit 0.
	EN0PPS	O	TTL	Ethernet 0 Pulse-Per-Second (PPS) Output.
	U3Rx	I	TTL	UART module 3 receive.
117	PJ1	I/O	TTL	GPIO port J bit 1.
	U3Tx	O	TTL	UART module 3 transmit.

Table 29-2. Signals by Pin Number (continued)

Pin Number	Pin Name	Pin Type	Buffer Type	Description
118	PP0	I/O	TTL	GPIO port P bit 0.
	C2+	I	Analog	Analog comparator 2 positive input.
	SSI3XDAT2	I/O	TTL	SSI Module 3 Bi-directional Data Pin 2.
	U6Rx	I	TTL	UART module 6 receive.
119	PP1	I/O	TTL	GPIO port P bit 1.
	C2-	I	Analog	Analog comparator 2 negative input.
	SSI3XDAT3	I/O	TTL	SSI Module 3 Bi-directional Data Pin 3.
	U6Tx	O	TTL	UART module 6 transmit.
120	PB5	I/O	TTL	GPIO port B bit 5.
	AIN11	I	Analog	Analog-to-digital converter input 11.
	I2C5SDA	I/O	OD	I ² C module 5 data.
	SSI1Clk	I/O	TTL	SSI module 1 clock.
	U0RTS	O	TTL	UART module 0 Request to Send modem flow control output signal.
121	PB4	I/O	TTL	GPIO port B bit 4.
	AIN10	I	Analog	Analog-to-digital converter input 10.
	I2C5SCL	I/O	OD	I ² C module 5 clock. Note that this signal has an active pull-up. The corresponding port pin should not be configured as open drain.
	SSI1Fss	I/O	TTL	SSI module 1 frame signal.
	U0CTS	I	TTL	UART module 0 Clear To Send modem flow control input signal.
122	VDD	-	Power	Positive supply for I/O and some logic.
123	PE4	I/O	TTL	GPIO port E bit 4.
	AIN9	I	Analog	Analog-to-digital converter input 9.
	SSI1XDAT0	I/O	TTL	SSI Module 1 Bi-directional Data Pin 0 (SSI1TX in Legacy SSI Mode).
	U1RI	I	TTL	UART module 1 Ring Indicator modem status input signal.
124	PE5	I/O	TTL	GPIO port E bit 5.
	AIN8	I	Analog	Analog-to-digital converter input 8.
	SSI1XDAT1	I/O	TTL	SSI Module 1 Bi-directional Data Pin 1 (SSI1RX in Legacy SSI Mode).
125	PD4	I/O	TTL	GPIO port D bit 4.
	AIN7	I	Analog	Analog-to-digital converter input 7.
	SSI1XDAT2	I/O	TTL	SSI Module 1 Bi-directional Data Pin 2.
	T3CCP0	I/O	TTL	16/32-Bit Timer 3 Capture/Compare/PWM 0.
	U2Rx	I	TTL	UART module 2 receive.
126	PD5	I/O	TTL	GPIO port D bit 5.
	AIN6	I	Analog	Analog-to-digital converter input 6.
	SSI1XDAT3	I/O	TTL	SSI Module 1 Bi-directional Data Pin 3.
	T3CCP1	I/O	TTL	16/32-Bit Timer 3 Capture/Compare/PWM 1.
	U2Tx	O	TTL	UART module 2 transmit.

Table 29-2. Signals by Pin Number (continued)

Pin Number	Pin Name	Pin Type	Buffer Type	Description
127	PD6	I/O	TTL	GPIO port D bit 6.
	AIN5	I	Analog	Analog-to-digital converter input 5.
	SSI2XDAT3	I/O	TTL	SSI Module 2 Bi-directional Data Pin 3.
	T4CCP0	I/O	TTL	16/32-Bit Timer 4 Capture/Compare/PWM 0.
	U2RTS	O	TTL	UART module 2 Request to Send modem flow control output line.
	USB0EPEN	O	TTL	Optionally used in Host mode to control an external power source to supply power to the USB bus.
128	PD7	I/O	TTL	GPIO port D bit 7.
	AIN4	I	Analog	Analog-to-digital converter input 4.
	NMI	I	TTL	Non-maskable interrupt.
	SSI2XDAT2	I/O	TTL	SSI Module 2 Bi-directional Data Pin 2.
	T4CCP1	I/O	TTL	16/32-Bit Timer 4 Capture/Compare/PWM 1.
	U2CTS	I	TTL	UART module 2 Clear To Send modem flow control input signal.
	USB0PFLT	I	TTL	Optionally used in Host mode by an external power source to indicate an error state by that power source.

29.2 Signals by Signal Name

Table 29-3. Signals by Signal Name

Pin Name	Pin Number	Pin Mux / Pin Assignment	Pin Type	Buffer Type	Description
AIN0	12	PE3	I	Analog	Analog-to-digital converter input 0.
AIN1	13	PE2	I	Analog	Analog-to-digital converter input 1.
AIN2	14	PE1	I	Analog	Analog-to-digital converter input 2.
AIN3	15	PE0	I	Analog	Analog-to-digital converter input 3.
AIN4	128	PD7	I	Analog	Analog-to-digital converter input 4.
AIN5	127	PD6	I	Analog	Analog-to-digital converter input 5.
AIN6	126	PD5	I	Analog	Analog-to-digital converter input 6.
AIN7	125	PD4	I	Analog	Analog-to-digital converter input 7.
AIN8	124	PE5	I	Analog	Analog-to-digital converter input 8.
AIN9	123	PE4	I	Analog	Analog-to-digital converter input 9.
AIN10	121	PB4	I	Analog	Analog-to-digital converter input 10.
AIN11	120	PB5	I	Analog	Analog-to-digital converter input 11.
AIN12	4	PD3	I	Analog	Analog-to-digital converter input 12.
AIN13	3	PD2	I	Analog	Analog-to-digital converter input 13.
AIN14	2	PD1	I	Analog	Analog-to-digital converter input 14.
AIN15	1	PD0	I	Analog	Analog-to-digital converter input 15.
AIN16	18	PK0	I	Analog	Analog-to-digital converter input 16.
AIN17	19	PK1	I	Analog	Analog-to-digital converter input 17.
AIN18	20	PK2	I	Analog	Analog-to-digital converter input 18.
AIN19	21	PK3	I	Analog	Analog-to-digital converter input 19.
CO+	23	PC6	I	Analog	Analog comparator 0 positive input.

Table 29-3. Signals by Signal Name (continued)

Pin Name	Pin Number	Pin Mux / Pin Assignment	Pin Type	Buffer Type	Description
C0-	22	PC7	I	Analog	Analog comparator 0 negative input.
C0o	1 83	PD0 (5) PL2 (5)	O	TTL	Analog comparator 0 output.
C1+	24	PC5	I	Analog	Analog comparator 1 positive input.
C1-	25	PC4	I	Analog	Analog comparator 1 negative input.
C1o	2 84	PD1 (5) PL3 (5)	O	TTL	Analog comparator 1 output.
C2+	118	PP0	I	Analog	Analog comparator 2 positive input.
C2-	119	PP1	I	Analog	Analog comparator 2 negative input.
C2o	3	PD2 (5)	O	TTL	Analog comparator 2 output.
CAN0Rx	33	PA0 (7)	I	TTL	CAN module 0 receive.
CAN0Tx	34	PA1 (7)	O	TTL	CAN module 0 transmit.
CAN1Rx	95	PB0 (7)	I	TTL	CAN module 1 receive.
CAN1Tx	96	PB1 (7)	O	TTL	CAN module 1 transmit.
DIVSCLK	102	PQ4 (7)	O	TTL	An optionally divided reference clock output based on a selected clock source. Note that this signal is not synchronized to the System Clock.
EN0LED0	42 63	PF0 (5) PK4 (5)	O	TTL	Ethernet 0 LED 0.
EN0LED1	46 61	PF4 (5) PK6 (5)	O	TTL	Ethernet 0 LED 1.
EN0LED2	43 62	PF1 (5) PK5 (5)	O	TTL	Ethernet 0 LED 2.
EN0PPS	49 116	PG0 (5) PJ0 (5)	O	TTL	Ethernet 0 Pulse-Per-Second (PPS) Output.
EN0RXIN	53	fixed	I/O	TTL	Ethernet PHY negative receive differential input.
EN0RXIP	54	fixed	I/O	TTL	Ethernet PHY positive receive differential input.
EN0TXON	56	fixed	I/O	TTL	Ethernet PHY negative transmit differential output.
EN0TXOP	57	fixed	I/O	TTL	Ethernet PHY positive transmit differential output.
EPI0S0	18 29	PK0 (15) PH0 (15)	I/O	TTL	EPI module 0 signal 0.
EPI0S1	19 30	PK1 (15) PH1 (15)	I/O	TTL	EPI module 0 signal 1.
EPI0S2	20 31	PK2 (15) PH2 (15)	I/O	TTL	EPI module 0 signal 2.
EPI0S3	21 32	PK3 (15) PH3 (15)	I/O	TTL	EPI module 0 signal 3.
EPI0S4	22	PC7 (15)	I/O	TTL	EPI module 0 signal 4.
EPI0S5	23	PC6 (15)	I/O	TTL	EPI module 0 signal 5.
EPI0S6	24	PC5 (15)	I/O	TTL	EPI module 0 signal 6.
EPI0S7	25	PC4 (15)	I/O	TTL	EPI module 0 signal 7.
EPI0S8	40	PA6 (15)	I/O	TTL	EPI module 0 signal 8.
EPI0S9	41	PA7 (15)	I/O	TTL	EPI module 0 signal 9.
EPI0S10	50	PG1 (15)	I/O	TTL	EPI module 0 signal 10.

Table 29-3. Signals by Signal Name (continued)

Pin Name	Pin Number	Pin Mux / Pin Assignment	Pin Type	Buffer Type	Description
EPI0S11	49	PG0 (15)	I/O	TTL	EPI module 0 signal 11.
EPI0S12	75	PM3 (15)	I/O	TTL	EPI module 0 signal 12.
EPI0S13	76	PM2 (15)	I/O	TTL	EPI module 0 signal 13.
EPI0S14	77	PM1 (15)	I/O	TTL	EPI module 0 signal 14.
EPI0S15	78	PM0 (15)	I/O	TTL	EPI module 0 signal 15.
EPI0S16	81	PL0 (15)	I/O	TTL	EPI module 0 signal 16.
EPI0S17	82	PL1 (15)	I/O	TTL	EPI module 0 signal 17.
EPI0S18	83	PL2 (15)	I/O	TTL	EPI module 0 signal 18.
EPI0S19	84	PL3 (15)	I/O	TTL	EPI module 0 signal 19.
EPI0S20	5	PQ0 (15)	I/O	TTL	EPI module 0 signal 20.
EPI0S21	6	PQ1 (15)	I/O	TTL	EPI module 0 signal 21.
EPI0S22	11	PQ2 (15)	I/O	TTL	EPI module 0 signal 22.
EPI0S23	27	PQ3 (15)	I/O	TTL	EPI module 0 signal 23.
EPI0S24	60	PK7 (15)	I/O	TTL	EPI module 0 signal 24.
EPI0S25	61	PK6 (15)	I/O	TTL	EPI module 0 signal 25.
EPI0S26	85	PL4 (15)	I/O	TTL	EPI module 0 signal 26.
EPI0S27	91	PB2 (15)	I/O	TTL	EPI module 0 signal 27.
EPI0S28	92	PB3 (15)	I/O	TTL	EPI module 0 signal 28.
EPI0S29	103 109	PP2 (15) PN2 (15)	I/O	TTL	EPI module 0 signal 29.
EPI0S30	104 110	PP3 (15) PN3 (15)	I/O	TTL	EPI module 0 signal 30.
EPI0S31	62	PK5 (15)	I/O	TTL	EPI module 0 signal 31.
EPI0S32	63	PK4 (15)	I/O	TTL	EPI module 0 signal 32.
EPI0S33	86	PL5 (15)	I/O	TTL	EPI module 0 signal 33.
EPI0S34	111	PN4 (15)	I/O	TTL	EPI module 0 signal 34.
EPI0S35	112	PN5 (15)	I/O	TTL	EPI module 0 signal 35.
GND	17 48 55 58 80 114	fixed	-	Power	Ground reference for logic and I/O pins.
GNDA	10	fixed	-	Power	The ground reference for the analog circuits (ADC, Analog Comparators, etc.). These are separated from GND to minimize the electrical noise contained on VDD from affecting the analog functions.
HIB	65	fixed	O	TTL	An output that indicates the processor is in Hibernate mode.
I2C0SCL	91	PB2 (2)	I/O	OD	I ² C module 0 clock. Note that this signal has an active pull-up. The corresponding port pin should not be configured as open drain.
I2C0SDA	92	PB3 (2)	I/O	OD	I ² C module 0 data.

Table 29-3. Signals by Signal Name (continued)

Pin Name	Pin Number	Pin Mux / Pin Assignment	Pin Type	Buffer Type	Description
I2C1SCL	49	PG0 (2)	I/O	OD	I ² C module 1 clock. Note that this signal has an active pull-up. The corresponding port pin should not be configured as open drain.
I2C1SDA	50	PG1 (2)	I/O	OD	I ² C module 1 data.
I2C2SCL	82 106 112	PL1 (2) PP5 (2) PN5 (3)	I/O	OD	I ² C module 2 clock. Note that this signal has an active pull-up. The corresponding port pin should not be configured as open drain.
I2C2SDA	81 111	PL0 (2) PN4 (3)	I/O	OD	I ² C module 2 data.
I2C3SCL	63	PK4 (2)	I/O	OD	I ² C module 3 clock. Note that this signal has an active pull-up. The corresponding port pin should not be configured as open drain.
I2C3SDA	62	PK5 (2)	I/O	OD	I ² C module 3 data.
I2C4SCL	61	PK6 (2)	I/O	OD	I ² C module 4 clock. Note that this signal has an active pull-up. The corresponding port pin should not be configured as open drain.
I2C4SDA	60	PK7 (2)	I/O	OD	I ² C module 4 data.
I2C5SCL	95 121	PB0 (2) PB4 (2)	I/O	OD	I ² C module 5 clock. Note that this signal has an active pull-up. The corresponding port pin should not be configured as open drain.
I2C5SDA	96 120	PB1 (2) PB5 (2)	I/O	OD	I ² C module 5 data.
I2C6SCL	40	PA6 (2)	I/O	OD	I ² C module 6 clock. Note that this signal has an active pull-up. The corresponding port pin should not be configured as open drain.
I2C6SDA	41	PA7 (2)	I/O	OD	I ² C module 6 data.
I2C7SCL	1 37	PD0 (2) PA4 (2)	I/O	OD	I ² C module 7 clock. Note that this signal has an active pull-up. The corresponding port pin should not be configured as open drain.
I2C7SDA	2 38	PD1 (2) PA5 (2)	I/O	OD	I ² C module 7 data.
I2C8SCL	3 35	PD2 (2) PA2 (2)	I/O	OD	I ² C module 8 clock. Note that this signal has an active pull-up. The corresponding port pin should not be configured as open drain.
I2C8SDA	4 36	PD3 (2) PA3 (2)	I/O	OD	I ² C module 8 data.
I2C9SCL	33	PA0 (2)	I/O	OD	I ² C module 9 clock. Note that this signal has an active pull-up. The corresponding port pin should not be configured as open drain.
I2C9SDA	34	PA1 (2)	I/O	OD	I ² C module 9 data.
IDX0	84	PL3 (6)	I	TTL	QE1 module 0 index.
M0FAULT0	46	PF4 (6)	I	TTL	Motion Control Module 0 PWM Fault 0.
M0FAULT1	61	PK6 (6)	I	TTL	Motion Control Module 0 PWM Fault 1.
M0FAULT2	60	PK7 (6)	I	TTL	Motion Control Module 0 PWM Fault 2.
M0FAULT3	81	PL0 (6)	I	TTL	Motion Control Module 0 PWM Fault 3.
M0PWM0	42	PF0 (6)	O	TTL	Motion Control Module 0 PWM 0. This signal is controlled by Module 0 PWM Generator 0.

Table 29-3. Signals by Signal Name (continued)

Pin Name	Pin Number	Pin Mux / Pin Assignment	Pin Type	Buffer Type	Description
M0PWM1	43	PF1 (6)	O	TTL	Motion Control Module 0 PWM 1. This signal is controlled by Module 0 PWM Generator 0.
M0PWM2	44	PF2 (6)	O	TTL	Motion Control Module 0 PWM 2. This signal is controlled by Module 0 PWM Generator 1.
M0PWM3	45	PF3 (6)	O	TTL	Motion Control Module 0 PWM 3. This signal is controlled by Module 0 PWM Generator 1.
M0PWM4	49	PG0 (6)	O	TTL	Motion Control Module 0 PWM 4. This signal is controlled by Module 0 PWM Generator 2.
M0PWM5	50	PG1 (6)	O	TTL	Motion Control Module 0 PWM 5. This signal is controlled by Module 0 PWM Generator 2.
M0PWM6	63	PK4 (6)	O	TTL	Motion Control Module 0 PWM 6. This signal is controlled by Module 0 PWM Generator 3.
M0PWM7	62	PK5 (6)	O	TTL	Motion Control Module 0 PWM 7. This signal is controlled by Module 0 PWM Generator 3.
NMI	128	PD7 (8)	I	TTL	Non-maskable interrupt.
OSC0	88	fixed	I	Analog	Main oscillator crystal input or an external clock reference input.
OSC1	89	fixed	O	Analog	Main oscillator crystal output. Leave unconnected when using a single-ended clock source.
PA0	33	-	I/O	TTL	GPIO port A bit 0.
PA1	34	-	I/O	TTL	GPIO port A bit 1.
PA2	35	-	I/O	TTL	GPIO port A bit 2.
PA3	36	-	I/O	TTL	GPIO port A bit 3.
PA4	37	-	I/O	TTL	GPIO port A bit 4.
PA5	38	-	I/O	TTL	GPIO port A bit 5.
PA6	40	-	I/O	TTL	GPIO port A bit 6.
PA7	41	-	I/O	TTL	GPIO port A bit 7.
PB0	95	-	I/O	TTL	GPIO port B bit 0.
PB1	96	-	I/O	TTL	GPIO port B bit 1.
PB2	91	-	I/O	TTL	GPIO port B bit 2.
PB3	92	-	I/O	TTL	GPIO port B bit 3.
PB4	121	-	I/O	TTL	GPIO port B bit 4.
PB5	120	-	I/O	TTL	GPIO port B bit 5.
PC0	100	-	I/O	TTL	GPIO port C bit 0.
PC1	99	-	I/O	TTL	GPIO port C bit 1.
PC2	98	-	I/O	TTL	GPIO port C bit 2.
PC3	97	-	I/O	TTL	GPIO port C bit 3.
PC4	25	-	I/O	TTL	GPIO port C bit 4.
PC5	24	-	I/O	TTL	GPIO port C bit 5.
PC6	23	-	I/O	TTL	GPIO port C bit 6.
PC7	22	-	I/O	TTL	GPIO port C bit 7.
PD0	1	-	I/O	TTL	GPIO port D bit 0.
PD1	2	-	I/O	TTL	GPIO port D bit 1.

Table 29-3. Signals by Signal Name (continued)

Pin Name	Pin Number	Pin Mux / Pin Assignment	Pin Type	Buffer Type	Description
PD2	3	-	I/O	TTL	GPIO port D bit 2.
PD3	4	-	I/O	TTL	GPIO port D bit 3.
PD4	125	-	I/O	TTL	GPIO port D bit 4.
PD5	126	-	I/O	TTL	GPIO port D bit 5.
PD6	127	-	I/O	TTL	GPIO port D bit 6.
PD7	128	-	I/O	TTL	GPIO port D bit 7.
PE0	15	-	I/O	TTL	GPIO port E bit 0.
PE1	14	-	I/O	TTL	GPIO port E bit 1.
PE2	13	-	I/O	TTL	GPIO port E bit 2.
PE3	12	-	I/O	TTL	GPIO port E bit 3.
PE4	123	-	I/O	TTL	GPIO port E bit 4.
PE5	124	-	I/O	TTL	GPIO port E bit 5.
PF0	42	-	I/O	TTL	GPIO port F bit 0.
PF1	43	-	I/O	TTL	GPIO port F bit 1.
PF2	44	-	I/O	TTL	GPIO port F bit 2.
PF3	45	-	I/O	TTL	GPIO port F bit 3.
PF4	46	-	I/O	TTL	GPIO port F bit 4.
PG0	49	-	I/O	TTL	GPIO port G bit 0.
PG1	50	-	I/O	TTL	GPIO port G bit 1.
PH0	29	-	I/O	TTL	GPIO port H bit 0.
PH1	30	-	I/O	TTL	GPIO port H bit 1.
PH2	31	-	I/O	TTL	GPIO port H bit 2.
PH3	32	-	I/O	TTL	GPIO port H bit 3.
PhA0	82	PL1 (6)	I	TTL	QEI module 0 phase A.
PhB0	83	PL2 (6)	I	TTL	QEI module 0 phase B.
PJ0	116	-	I/O	TTL	GPIO port J bit 0.
PJ1	117	-	I/O	TTL	GPIO port J bit 1.
PK0	18	-	I/O	TTL	GPIO port K bit 0.
PK1	19	-	I/O	TTL	GPIO port K bit 1.
PK2	20	-	I/O	TTL	GPIO port K bit 2.
PK3	21	-	I/O	TTL	GPIO port K bit 3.
PK4	63	-	I/O	TTL	GPIO port K bit 4.
PK5	62	-	I/O	TTL	GPIO port K bit 5.
PK6	61	-	I/O	TTL	GPIO port K bit 6.
PK7	60	-	I/O	TTL	GPIO port K bit 7.
PL0	81	-	I/O	TTL	GPIO port L bit 0.
PL1	82	-	I/O	TTL	GPIO port L bit 1.
PL2	83	-	I/O	TTL	GPIO port L bit 2.
PL3	84	-	I/O	TTL	GPIO port L bit 3.
PL4	85	-	I/O	TTL	GPIO port L bit 4.
PL5	86	-	I/O	TTL	GPIO port L bit 5.

Table 29-3. Signals by Signal Name (continued)

Pin Name	Pin Number	Pin Mux / Pin Assignment	Pin Type	Buffer Type	Description
PL6	94	-	I/O	TTL	GPIO port L bit 6.
PL7	93	-	I/O	TTL	GPIO port L bit 7.
PM0	78	-	I/O	TTL	GPIO port M bit 0.
PM1	77	-	I/O	TTL	GPIO port M bit 1.
PM2	76	-	I/O	TTL	GPIO port M bit 2.
PM3	75	-	I/O	TTL	GPIO port M bit 3.
PM4	74	-	I/O	TTL	GPIO port M bit 4.
PM5	73	-	I/O	TTL	GPIO port M bit 5.
PM6	72	-	I/O	TTL	GPIO port M bit 6.
PM7	71	-	I/O	TTL	GPIO port M bit 7.
PN0	107	-	I/O	TTL	GPIO port N bit 0.
PN1	108	-	I/O	TTL	GPIO port N bit 1.
PN2	109	-	I/O	TTL	GPIO port N bit 2.
PN3	110	-	I/O	TTL	GPIO port N bit 3.
PN4	111	-	I/O	TTL	GPIO port N bit 4.
PN5	112	-	I/O	TTL	GPIO port N bit 5.
PP0	118	-	I/O	TTL	GPIO port P bit 0.
PP1	119	-	I/O	TTL	GPIO port P bit 1.
PP2	103	-	I/O	TTL	GPIO port P bit 2.
PP3	104	-	I/O	TTL	GPIO port P bit 3.
PP4	105	-	I/O	TTL	GPIO port P bit 4.
PP5	106	-	I/O	TTL	GPIO port P bit 5.
PQ0	5	-	I/O	TTL	GPIO port Q bit 0.
PQ1	6	-	I/O	TTL	GPIO port Q bit 1.
PQ2	11	-	I/O	TTL	GPIO port Q bit 2.
PQ3	27	-	I/O	TTL	GPIO port Q bit 3.
PQ4	102	-	I/O	TTL	GPIO port Q bit 4.
RBIAS	59	fixed	O	Analog	4.87-kΩ resistor (1% precision) for Ethernet PHY.
RST	70	fixed	I	TTL	System reset input.
RTCCLK	24 60 104	PC5 (7) PK7 (5) PP3 (7)	O	TTL	Buffered version of the Hibernation module's 32.768-kHz clock. This signal is not output when the part is in Hibernate mode and before being configured after power-on reset.
SSI0Clk	35	PA2 (15)	I/O	TTL	SSI module 0 clock
SSI0Fss	36	PA3 (15)	I/O	TTL	SSI module 0 frame signal
SSI0XDAT0	37	PA4 (15)	I/O	TTL	SSI Module 0 Bi-directional Data Pin 0 (SSI0TX in Legacy SSI Mode).
SSI0XDAT1	38	PA5 (15)	I/O	TTL	SSI Module 0 Bi-directional Data Pin 1 (SSI0RX in Legacy SSI Mode).
SSI0XDAT2	40	PA6 (13)	I/O	TTL	SSI Module 0 Bi-directional Data Pin 2.
SSI0XDAT3	41	PA7 (13)	I/O	TTL	SSI Module 0 Bi-directional Data Pin 3.
SSI1Clk	120	PB5 (15)	I/O	TTL	SSI module 1 clock.

Table 29-3. Signals by Signal Name (continued)

Pin Name	Pin Number	Pin Mux / Pin Assignment	Pin Type	Buffer Type	Description
SSI1Fss	121	PB4 (15)	I/O	TTL	SSI module 1 frame signal.
SSI1XDAT0	123	PE4 (15)	I/O	TTL	SSI Module 1 Bi-directional Data Pin 0 (SSI1TX in Legacy SSI Mode).
SSI1XDAT1	124	PE5 (15)	I/O	TTL	SSI Module 1 Bi-directional Data Pin 1 (SSI1RX in Legacy SSI Mode).
SSI1XDAT2	125	PD4 (15)	I/O	TTL	SSI Module 1 Bi-directional Data Pin 2.
SSI1XDAT3	126	PD5 (15)	I/O	TTL	SSI Module 1 Bi-directional Data Pin 3.
SSI2Clk	4	PD3 (15)	I/O	TTL	SSI module 2 clock.
SSI2Fss	3	PD2 (15)	I/O	TTL	SSI module 2 frame signal.
SSI2XDAT0	2	PD1 (15)	I/O	TTL	SSI Module 2 Bi-directional Data Pin 0 (SSI2TX in Legacy SSI Mode).
SSI2XDAT1	1	PD0 (15)	I/O	TTL	SSI Module 2 Bi-directional Data Pin 1 (SSI2RX in Legacy SSI Mode).
SSI2XDAT2	128	PD7 (15)	I/O	TTL	SSI Module 2 Bi-directional Data Pin 2.
SSI2XDAT3	127	PD6 (15)	I/O	TTL	SSI Module 2 Bi-directional Data Pin 3.
SSI3Clk	5 45	PQ0 (14) PF3 (14)	I/O	TTL	SSI module 3 clock.
SSI3Fss	6 44	PQ1 (14) PF2 (14)	I/O	TTL	SSI module 3 frame signal.
SSI3XDAT0	11 43	PQ2 (14) PF1 (14)	I/O	TTL	SSI Module 3 Bi-directional Data Pin 0 (SSI3TX in Legacy SSI Mode).
SSI3XDAT1	27 42	PQ3 (14) PF0 (14)	I/O	TTL	SSI Module 3 Bi-directional Data Pin 1 (SSI3RX in Legacy SSI Mode).
SSI3XDAT2	46 118	PF4 (14) PP0 (15)	I/O	TTL	SSI Module 3 Bi-directional Data Pin 2.
SSI3XDAT3	119	PP1 (15)	I/O	TTL	SSI Module 3 Bi-directional Data Pin 3.
SWCLK	100	PC0 (1)	I	TTL	JTAG/SWD CLK.
SWDIO	99	PC1 (1)	I/O	TTL	JTAG TMS and SWDIO.
SWO	97	PC3 (1)	O	TTL	JTAG TDO and SWO.
T0CCP0	1 33 85	PD0 (3) PA0 (3) PL4 (3)	I/O	TTL	16/32-Bit Timer 0 Capture/Compare/PWM 0.
T0CCP1	2 34 86	PD1 (3) PA1 (3) PL5 (3)	I/O	TTL	16/32-Bit Timer 0 Capture/Compare/PWM 1.
T1CCP0	3 35 94	PD2 (3) PA2 (3) PL6 (3)	I/O	TTL	16/32-Bit Timer 1 Capture/Compare/PWM 0.
T1CCP1	4 36 93	PD3 (3) PA3 (3) PL7 (3)	I/O	TTL	16/32-Bit Timer 1 Capture/Compare/PWM 1.
T2CCP0	37 78	PA4 (3) PM0 (3)	I/O	TTL	16/32-Bit Timer 2 Capture/Compare/PWM 0.
T2CCP1	38 77	PA5 (3) PM1 (3)	I/O	TTL	16/32-Bit Timer 2 Capture/Compare/PWM 1.

Table 29-3. Signals by Signal Name (continued)

Pin Name	Pin Number	Pin Mux / Pin Assignment	Pin Type	Buffer Type	Description
T3CCP0	40 76 125	PA6 (3) PM2 (3) PD4 (3)	I/O	TTL	16/32-Bit Timer 3 Capture/Compare/PWM 0.
T3CCP1	41 75 126	PA7 (3) PM3 (3) PD5 (3)	I/O	TTL	16/32-Bit Timer 3 Capture/Compare/PWM 1.
T4CCP0	74 95 127	PM4 (3) PB0 (3) PD6 (3)	I/O	TTL	16/32-Bit Timer 4 Capture/Compare/PWM 0.
T4CCP1	73 96 128	PM5 (3) PB1 (3) PD7 (3)	I/O	TTL	16/32-Bit Timer 4 Capture/Compare/PWM 1.
T5CCP0	72 91	PM6 (3) PB2 (3)	I/O	TTL	16/32-Bit Timer 5 Capture/Compare/PWM 0.
T5CCP1	71 92	PM7 (3) PB3 (3)	I/O	TTL	16/32-Bit Timer 5 Capture/Compare/PWM 1.
TCK	100	PC0 (1)	I	TTL	JTAG/SWD CLK.
TDI	98	PC2 (1)	I	TTL	JTAG TDI.
TDO	97	PC3 (1)	O	TTL	JTAG TDO and SWO.
TMPR0	71	PM7	I/O	TTL	Tamper signal 0.
TMPR1	72	PM6	I/O	TTL	Tamper signal 1.
TMPR2	73	PM5	I/O	TTL	Tamper signal 2.
TMPR3	74	PM4	I/O	TTL	Tamper signal 3.
TMS	99	PC1 (1)	I	TTL	JTAG TMS and SWDIO.
TRCLK	45	PF3 (15)	O	TTL	Trace clock.
TRD0	44	PF2 (15)	O	TTL	Trace data 0.
TRD1	43	PF1 (15)	O	TTL	Trace data 1.
TRD2	42	PF0 (15)	O	TTL	Trace data 2.
TRD3	46	PF4 (15)	O	TTL	Trace data 3.
U0CTS	30 74 121	PH1 (1) PM4 (1) PB4 (1)	I	TTL	UART module 0 Clear To Send modem flow control input signal.
U0DCD	31 73 104	PH2 (1) PM5 (1) PP3 (2)	I	TTL	UART module 0 Data Carrier Detect modem status input signal.
U0DSR	32 72 105	PH3 (1) PM6 (1) PP4 (2)	I	TTL	UART module 0 Data Set Ready modem output control line.
U0DTR	103	PP2 (1)	O	TTL	UART module 0 Data Terminal Ready modem status input signal.
U0RI	60 71	PK7 (1) PM7 (1)	I	TTL	UART module 0 Ring Indicator modem status input signal.
U0RTS	29 120	PH0 (1) PB5 (1)	O	TTL	UART module 0 Request to Send modem flow control output signal.
U0Rx	33	PA0 (1)	I	TTL	UART module 0 receive.
U0Tx	34	PA1 (1)	O	TTL	UART module 0 transmit.

Table 29-3. Signals by Signal Name (continued)

Pin Name	Pin Number	Pin Mux / Pin Assignment	Pin Type	Buffer Type	Description
U1CTS	104 108	PP3 (1) PN1 (1)	I	TTL	UART module 1 Clear To Send modem flow control input signal.
U1DCD	13 109	PE2 (1) PN2 (1)	I	TTL	UART module 1 Data Carrier Detect modem status input signal.
U1DSR	14 110	PE1 (1) PN3 (1)	I	TTL	UART module 1 Data Set Ready modem output control line.
U1DTR	12 111	PE3 (1) PN4 (1)	O	TTL	UART module 1 Data Terminal Ready modem status input signal.
U1RI	112 123	PN5 (1) PE4 (1)	I	TTL	UART module 1 Ring Indicator modem status input signal.
U1RTS	15 107	PE0 (1) PN0 (1)	O	TTL	UART module 1 Request to Send modem flow control output line.
U1Rx	95 102	PB0 (1) PQ4 (1)	I	TTL	UART module 1 receive.
U1Tx	96	PB1 (1)	O	TTL	UART module 1 transmit.
U2CTS	110 128	PN3 (2) PD7 (1)	I	TTL	UART module 2 Clear To Send modem flow control input signal.
U2RTS	109 127	PN2 (2) PD6 (1)	O	TTL	UART module 2 Request to Send modem flow control output line.
U2Rx	40 125	PA6 (1) PD4 (1)	I	TTL	UART module 2 receive.
U2Tx	41 126	PA7 (1) PD5 (1)	O	TTL	UART module 2 transmit.
U3CTS	106 112	PP5 (1) PN5 (2)	I	TTL	UART module 3 Clear To Send modem flow control input signal.
U3RTS	105 111	PP4 (1) PN4 (2)	O	TTL	UART module 3 Request to Send modem flow control output line.
U3Rx	37 116	PA4 (1) PJ0 (1)	I	TTL	UART module 3 receive.
U3Tx	38 117	PA5 (1) PJ1 (1)	O	TTL	UART module 3 transmit.
U4CTS	21	PK3 (1)	I	TTL	UART module 4 Clear To Send modem flow control input signal.
U4RTS	20	PK2 (1)	O	TTL	UART module 4 Request to Send modem flow control output line.
U4Rx	18 35	PK0 (1) PA2 (1)	I	TTL	UART module 4 receive.
U4Tx	19 36	PK1 (1) PA3 (1)	O	TTL	UART module 4 transmit.
U5Rx	23	PC6 (1)	I	TTL	UART module 5 receive.
U5Tx	22	PC7 (1)	O	TTL	UART module 5 transmit.
U6Rx	118	PP0 (1)	I	TTL	UART module 6 receive.
U6Tx	119	PP1 (1)	O	TTL	UART module 6 transmit.
U7Rx	25	PC4 (1)	I	TTL	UART module 7 receive.
U7Tx	24	PC5 (1)	O	TTL	UART module 7 transmit.
USB0CLK	92	PB3 (14)	O	TTL	60-MHz clock to the external PHY.
USB0D0	81	PL0 (14)	I/O	TTL	USB data 0.

Table 29-3. Signals by Signal Name (continued)

Pin Name	Pin Number	Pin Mux / Pin Assignment	Pin Type	Buffer Type	Description
USB0D1	82	PL1 (14)	I/O	TTL	USB data 1.
USB0D2	83	PL2 (14)	I/O	TTL	USB data 2.
USB0D3	84	PL3 (14)	I/O	TTL	USB data 3.
USB0D4	85	PL4 (14)	I/O	TTL	USB data 4.
USB0D5	86	PL5 (14)	I/O	TTL	USB data 5.
USB0D6	106	PP5 (14)	I/O	TTL	USB data 6.
USB0D7	105	PP4 (14)	I/O	TTL	USB data 7.
USB0DIR	104	PP3 (14)	O	TTL	Indicates that the external PHY is able to accept data from the USB controller.
USB0DM	93	PL7	I/O	Analog	Bidirectional differential data pin (D- per USB specification) for USB0.
USB0DP	94	PL6	I/O	Analog	Bidirectional differential data pin (D+ per USB specification) for USB0.
USB0EPEN	40 41 127	PA6 (5) PA7 (11) PD6 (5)	O	TTL	Optionally used in Host mode to control an external power source to supply power to the USB bus.
USB0ID	95	PB0	I	Analog	This signal senses the state of the USB ID signal. The USB PHY enables an integrated pull-up, and an external element (USB connector) indicates the initial state of the USB controller (pulled down is the A side of the cable and pulled up is the B side).
USB0NXT	103	PP2 (14)	O	TTL	Asserted by the external PHY to throttle all data types.
USB0PFLT	41 128	PA7 (5) PD7 (5)	I	TTL	Optionally used in Host mode by an external power source to indicate an error state by that power source.
USB0STP	91	PB2 (14)	O	TTL	Asserted by the USB controller to signal the end of a USB transmit packet or register write operation.
USB0VBUS	96	PB1	I/O	Analog	This signal is used during the session request protocol. This signal allows the USB PHY to both sense the voltage level of VBUS, and pull up VBUS momentarily during VBUS pulsing.
VBAT	68	fixed	-	Power	Power source for the Hibernation module. It is normally connected to the positive terminal of a battery and serves as the battery backup/Hibernation module power-source supply.
VDD	7 16 26 28 39 47 51 52 69 79 90 101 113 122	fixed	-	Power	Positive supply for I/O and some logic.

Table 29-3. Signals by Signal Name (continued)

Pin Name	Pin Number	Pin Mux / Pin Assignment	Pin Type	Buffer Type	Description
VDDA	8	fixed	-	Power	The positive supply for the analog circuits (ADC, Analog Comparators, etc.). These are separated from VDD to minimize the electrical noise contained on VDD from affecting the analog functions. VDDA pins must be supplied with a voltage that meets the specification in , regardless of system implementation.
VDDC	87 115	fixed	-	Power	Positive supply for most of the logic function, including the processor core and most peripherals. The voltage on this pin is 1.2 V and is supplied by the on-chip LDO. The VDDC pins should only be connected to each other and an external capacitor as specified in Table 30-15 on page 1958 .
VREFA+	9	fixed	-	Analog	A reference voltage used to specify the voltage at which the ADC converts to a maximum value. This pin is used in conjunction with GND _A . The voltage that is applied to VREFA+ is the voltage with which an AIN _n signal is converted to 4095. The VREFA+ voltage is limited to the range specified in Table 30-44 on page 1985.
$\overline{\text{WAKE}}$	64	fixed	I	TTL	An external input that brings the processor out of Hibernate mode when asserted.
XOSC0	66	fixed	I	Analog	Hibernation module oscillator crystal input or an external clock reference input. Note that this is either a crystal or a 32.768-kHz oscillator for the Hibernation module RTC.
XOSC1	67	fixed	O	Analog	Hibernation module oscillator crystal output. Leave unconnected when using a single-ended clock source.

29.3 Signals by Function, Except for GPIO

Table 29-4. Signals by Function, Except for GPIO

Function	Pin Name	Pin Number	Pin Type	Buffer Type	Description
ADC	AIN0	12	I	Analog	Analog-to-digital converter input 0.
	AIN1	13	I	Analog	Analog-to-digital converter input 1.
	AIN2	14	I	Analog	Analog-to-digital converter input 2.
	AIN3	15	I	Analog	Analog-to-digital converter input 3.
	AIN4	128	I	Analog	Analog-to-digital converter input 4.
	AIN5	127	I	Analog	Analog-to-digital converter input 5.
	AIN6	126	I	Analog	Analog-to-digital converter input 6.
	AIN7	125	I	Analog	Analog-to-digital converter input 7.
	AIN8	124	I	Analog	Analog-to-digital converter input 8.
	AIN9	123	I	Analog	Analog-to-digital converter input 9.
	AIN10	121	I	Analog	Analog-to-digital converter input 10.
	AIN11	120	I	Analog	Analog-to-digital converter input 11.
	AIN12	4	I	Analog	Analog-to-digital converter input 12.
	AIN13	3	I	Analog	Analog-to-digital converter input 13.
	AIN14	2	I	Analog	Analog-to-digital converter input 14.
	AIN15	1	I	Analog	Analog-to-digital converter input 15.
	AIN16	18	I	Analog	Analog-to-digital converter input 16.
	AIN17	19	I	Analog	Analog-to-digital converter input 17.
	AIN18	20	I	Analog	Analog-to-digital converter input 18.
	AIN19	21	I	Analog	Analog-to-digital converter input 19.
	VREFA+	9	-	Analog	A reference voltage used to specify the voltage at which the ADC converts to a maximum value. This pin is used in conjunction with GND _A . The voltage that is applied to VREFA+ is the voltage with which an AIN _n signal is converted to 4095. The VREFA+ voltage is limited to the range specified in Table 30-44 on page 1985.
Analog Comparators	C0+	23	I	Analog	Analog comparator 0 positive input.
	C0-	22	I	Analog	Analog comparator 0 negative input.
	C0o	1 83	O	TTL	Analog comparator 0 output.
	C1+	24	I	Analog	Analog comparator 1 positive input.
	C1-	25	I	Analog	Analog comparator 1 negative input.
	C1o	2 84	O	TTL	Analog comparator 1 output.
	C2+	118	I	Analog	Analog comparator 2 positive input.
	C2-	119	I	Analog	Analog comparator 2 negative input.
	C2o	3	O	TTL	Analog comparator 2 output.
Controller Area Network	CAN0Rx	33	I	TTL	CAN module 0 receive.
	CAN0Tx	34	O	TTL	CAN module 0 transmit.
	CAN1Rx	95	I	TTL	CAN module 1 receive.
	CAN1Tx	96	O	TTL	CAN module 1 transmit.

Table 29-4. Signals by Function, Except for GPIO (continued)

Function	Pin Name	Pin Number	Pin Type	Buffer Type	Description
Core	TRCLK	45	O	TTL	Trace clock.
	TRD0	44	O	TTL	Trace data 0.
	TRD1	43	O	TTL	Trace data 1.
	TRD2	42	O	TTL	Trace data 2.
	TRD3	46	O	TTL	Trace data 3.
Ethernet	ENOLED0	42 63	O	TTL	Ethernet 0 LED 0.
	ENOLED1	46 61	O	TTL	Ethernet 0 LED 1.
	ENOLED2	43 62	O	TTL	Ethernet 0 LED 2.
	ENOPPS	49 116	O	TTL	Ethernet 0 Pulse-Per-Second (PPS) Output.
	ENORXIN	53	I/O	TTL	Ethernet PHY negative receive differential input.
	ENORXIP	54	I/O	TTL	Ethernet PHY positive receive differential input.
	ENOTXON	56	I/O	TTL	Ethernet PHY negative transmit differential output.
	ENOTXOP	57	I/O	TTL	Ethernet PHY positive transmit differential output.
	RBIAS	59	O	Analog	4.87-k Ω resistor (1% precision) for Ethernet PHY.

Table 29-4. Signals by Function, Except for GPIO (continued)

Function	Pin Name	Pin Number	Pin Type	Buffer Type	Description
External Peripheral Interface	EPI0S0	18 29	I/O	TTL	EPI module 0 signal 0.
	EPI0S1	19 30	I/O	TTL	EPI module 0 signal 1.
	EPI0S2	20 31	I/O	TTL	EPI module 0 signal 2.
	EPI0S3	21 32	I/O	TTL	EPI module 0 signal 3.
	EPI0S4	22	I/O	TTL	EPI module 0 signal 4.
	EPI0S5	23	I/O	TTL	EPI module 0 signal 5.
	EPI0S6	24	I/O	TTL	EPI module 0 signal 6.
	EPI0S7	25	I/O	TTL	EPI module 0 signal 7.
	EPI0S8	40	I/O	TTL	EPI module 0 signal 8.
	EPI0S9	41	I/O	TTL	EPI module 0 signal 9.
	EPI0S10	50	I/O	TTL	EPI module 0 signal 10.
	EPI0S11	49	I/O	TTL	EPI module 0 signal 11.
	EPI0S12	75	I/O	TTL	EPI module 0 signal 12.
	EPI0S13	76	I/O	TTL	EPI module 0 signal 13.
	EPI0S14	77	I/O	TTL	EPI module 0 signal 14.
	EPI0S15	78	I/O	TTL	EPI module 0 signal 15.
	EPI0S16	81	I/O	TTL	EPI module 0 signal 16.
	EPI0S17	82	I/O	TTL	EPI module 0 signal 17.
	EPI0S18	83	I/O	TTL	EPI module 0 signal 18.
	EPI0S19	84	I/O	TTL	EPI module 0 signal 19.
	EPI0S20	5	I/O	TTL	EPI module 0 signal 20.
	EPI0S21	6	I/O	TTL	EPI module 0 signal 21.
	EPI0S22	11	I/O	TTL	EPI module 0 signal 22.
	EPI0S23	27	I/O	TTL	EPI module 0 signal 23.
	EPI0S24	60	I/O	TTL	EPI module 0 signal 24.
	EPI0S25	61	I/O	TTL	EPI module 0 signal 25.
	EPI0S26	85	I/O	TTL	EPI module 0 signal 26.
	EPI0S27	91	I/O	TTL	EPI module 0 signal 27.
	EPI0S28	92	I/O	TTL	EPI module 0 signal 28.
	EPI0S29	103 109	I/O	TTL	EPI module 0 signal 29.
	EPI0S30	104 110	I/O	TTL	EPI module 0 signal 30.
	EPI0S31	62	I/O	TTL	EPI module 0 signal 31.
	EPI0S32	63	I/O	TTL	EPI module 0 signal 32.
	EPI0S33	86	I/O	TTL	EPI module 0 signal 33.
	EPI0S34	111	I/O	TTL	EPI module 0 signal 34.
EPI0S35	112	I/O	TTL	EPI module 0 signal 35.	

Table 29-4. Signals by Function, Except for GPIO (continued)

Function	Pin Name	Pin Number	Pin Type	Buffer Type	Description
General-Purpose Timers	T0CCP0	1 33 85	I/O	TTL	16/32-Bit Timer 0 Capture/Compare/PWM 0.
	T0CCP1	2 34 86	I/O	TTL	16/32-Bit Timer 0 Capture/Compare/PWM 1.
	T1CCP0	3 35 94	I/O	TTL	16/32-Bit Timer 1 Capture/Compare/PWM 0.
	T1CCP1	4 36 93	I/O	TTL	16/32-Bit Timer 1 Capture/Compare/PWM 1.
	T2CCP0	37 78	I/O	TTL	16/32-Bit Timer 2 Capture/Compare/PWM 0.
	T2CCP1	38 77	I/O	TTL	16/32-Bit Timer 2 Capture/Compare/PWM 1.
	T3CCP0	40 76 125	I/O	TTL	16/32-Bit Timer 3 Capture/Compare/PWM 0.
	T3CCP1	41 75 126	I/O	TTL	16/32-Bit Timer 3 Capture/Compare/PWM 1.
	T4CCP0	74 95 127	I/O	TTL	16/32-Bit Timer 4 Capture/Compare/PWM 0.
	T4CCP1	73 96 128	I/O	TTL	16/32-Bit Timer 4 Capture/Compare/PWM 1.
	T5CCP0	72 91	I/O	TTL	16/32-Bit Timer 5 Capture/Compare/PWM 0.
	T5CCP1	71 92	I/O	TTL	16/32-Bit Timer 5 Capture/Compare/PWM 1.

Table 29-4. Signals by Function, Except for GPIO (continued)

Function	Pin Name	Pin Number	Pin Type	Buffer Type	Description
Hibernate	HIB	65	O	TTL	An output that indicates the processor is in Hibernate mode.
	RTCCCLK	24 60 104	O	TTL	Buffered version of the Hibernation module's 32.768-kHz clock. This signal is not output when the part is in Hibernate mode and before being configured after power-on reset.
	TMPR0	71	I/O	TTL	Tamper signal 0.
	TMPR1	72	I/O	TTL	Tamper signal 1.
	TMPR2	73	I/O	TTL	Tamper signal 2.
	TMPR3	74	I/O	TTL	Tamper signal 3.
	VBAT	68	-	Power	Power source for the Hibernation module. It is normally connected to the positive terminal of a battery and serves as the battery backup/Hibernation module power-source supply.
	WAKE	64	I	TTL	An external input that brings the processor out of Hibernate mode when asserted.
	XOSC0	66	I	Analog	Hibernation module oscillator crystal input or an external clock reference input. Note that this is either a crystal or a 32.768-kHz oscillator for the Hibernation module RTC.
	XOSC1	67	O	Analog	Hibernation module oscillator crystal output. Leave unconnected when using a single-ended clock source.

Table 29-4. Signals by Function, Except for GPIO (continued)

Function	Pin Name	Pin Number	Pin Type	Buffer Type	Description
I2C	I2C0SCL	91	I/O	OD	I ² C module 0 clock. Note that this signal has an active pull-up. The corresponding port pin should not be configured as open drain.
	I2C0SDA	92	I/O	OD	I ² C module 0 data.
	I2C1SCL	49	I/O	OD	I ² C module 1 clock. Note that this signal has an active pull-up. The corresponding port pin should not be configured as open drain.
	I2C1SDA	50	I/O	OD	I ² C module 1 data.
	I2C2SCL	82 106 112	I/O	OD	I ² C module 2 clock. Note that this signal has an active pull-up. The corresponding port pin should not be configured as open drain.
	I2C2SDA	81 111	I/O	OD	I ² C module 2 data.
	I2C3SCL	63	I/O	OD	I ² C module 3 clock. Note that this signal has an active pull-up. The corresponding port pin should not be configured as open drain.
	I2C3SDA	62	I/O	OD	I ² C module 3 data.
	I2C4SCL	61	I/O	OD	I ² C module 4 clock. Note that this signal has an active pull-up. The corresponding port pin should not be configured as open drain.
	I2C4SDA	60	I/O	OD	I ² C module 4 data.
	I2C5SCL	95 121	I/O	OD	I ² C module 5 clock. Note that this signal has an active pull-up. The corresponding port pin should not be configured as open drain.
	I2C5SDA	96 120	I/O	OD	I ² C module 5 data.
	I2C6SCL	40	I/O	OD	I ² C module 6 clock. Note that this signal has an active pull-up. The corresponding port pin should not be configured as open drain.
	I2C6SDA	41	I/O	OD	I ² C module 6 data.
	I2C7SCL	1 37	I/O	OD	I ² C module 7 clock. Note that this signal has an active pull-up. The corresponding port pin should not be configured as open drain.
	I2C7SDA	2 38	I/O	OD	I ² C module 7 data.
	I2C8SCL	3 35	I/O	OD	I ² C module 8 clock. Note that this signal has an active pull-up. The corresponding port pin should not be configured as open drain.
	I2C8SDA	4 36	I/O	OD	I ² C module 8 data.
I2C9SCL	33	I/O	OD	I ² C module 9 clock. Note that this signal has an active pull-up. The corresponding port pin should not be configured as open drain.	
I2C9SDA	34	I/O	OD	I ² C module 9 data.	

Table 29-4. Signals by Function, Except for GPIO (continued)

Function	Pin Name	Pin Number	Pin Type	Buffer Type	Description
JTAG/SWD/SWO	SWCLK	100	I	TTL	JTAG/SWD CLK.
	SWDIO	99	I/O	TTL	JTAG TMS and SWDIO.
	SWO	97	O	TTL	JTAG TDO and SWO.
	TCK	100	I	TTL	JTAG/SWD CLK.
	TDI	98	I	TTL	JTAG TDI.
	TDO	97	O	TTL	JTAG TDO and SWO.
	TMS	99	I	TTL	JTAG TMS and SWDIO.
PWM	MOFAULT0	46	I	TTL	Motion Control Module 0 PWM Fault 0.
	MOFAULT1	61	I	TTL	Motion Control Module 0 PWM Fault 1.
	MOFAULT2	60	I	TTL	Motion Control Module 0 PWM Fault 2.
	MOFAULT3	81	I	TTL	Motion Control Module 0 PWM Fault 3.
	MOPWM0	42	O	TTL	Motion Control Module 0 PWM 0. This signal is controlled by Module 0 PWM Generator 0.
	MOPWM1	43	O	TTL	Motion Control Module 0 PWM 1. This signal is controlled by Module 0 PWM Generator 0.
	MOPWM2	44	O	TTL	Motion Control Module 0 PWM 2. This signal is controlled by Module 0 PWM Generator 1.
	MOPWM3	45	O	TTL	Motion Control Module 0 PWM 3. This signal is controlled by Module 0 PWM Generator 1.
	MOPWM4	49	O	TTL	Motion Control Module 0 PWM 4. This signal is controlled by Module 0 PWM Generator 2.
	MOPWM5	50	O	TTL	Motion Control Module 0 PWM 5. This signal is controlled by Module 0 PWM Generator 2.
	MOPWM6	63	O	TTL	Motion Control Module 0 PWM 6. This signal is controlled by Module 0 PWM Generator 3.
	MOPWM7	62	O	TTL	Motion Control Module 0 PWM 7. This signal is controlled by Module 0 PWM Generator 3.

Table 29-4. Signals by Function, Except for GPIO (continued)

Function	Pin Name	Pin Number	Pin Type	Buffer Type	Description
Power	GND	17 48 55 58 80 114	-	Power	Ground reference for logic and I/O pins.
	GNDA	10	-	Power	The ground reference for the analog circuits (ADC, Analog Comparators, etc.). These are separated from GND to minimize the electrical noise contained on VDD from affecting the analog functions.
	VDD	7 16 26 28 39 47 51 52 69 79 90 101 113 122	-	Power	Positive supply for I/O and some logic.
	VDDA	8	-	Power	The positive supply for the analog circuits (ADC, Analog Comparators, etc.). These are separated from VDD to minimize the electrical noise contained on VDD from affecting the analog functions. VDDA pins must be supplied with a voltage that meets the specification in , regardless of system implementation.
	VDDC	87 115	-	Power	Positive supply for most of the logic function, including the processor core and most peripherals. The voltage on this pin is 1.2 V and is supplied by the on-chip LDO. The VDDC pins should only be connected to each other and an external capacitor as specified in Table 30-15 on page 1958 .
QEI	IDX0	84	I	TTL	QEI module 0 index.
	PhA0	82	I	TTL	QEI module 0 phase A.
	PhB0	83	I	TTL	QEI module 0 phase B.

Table 29-4. Signals by Function, Except for GPIO (continued)

Function	Pin Name	Pin Number	Pin Type	Buffer Type	Description
SSI	SSI0Clk	35	I/O	TTL	SSI module 0 clock
	SSI0Fss	36	I/O	TTL	SSI module 0 frame signal
	SSI0XDAT0	37	I/O	TTL	SSI Module 0 Bi-directional Data Pin 0 (SSI0TX in Legacy SSI Mode).
	SSI0XDAT1	38	I/O	TTL	SSI Module 0 Bi-directional Data Pin 1 (SSI0RX in Legacy SSI Mode).
	SSI0XDAT2	40	I/O	TTL	SSI Module 0 Bi-directional Data Pin 2.
	SSI0XDAT3	41	I/O	TTL	SSI Module 0 Bi-directional Data Pin 3.
	SSI1Clk	120	I/O	TTL	SSI module 1 clock.
	SSI1Fss	121	I/O	TTL	SSI module 1 frame signal.
	SSI1XDAT0	123	I/O	TTL	SSI Module 1 Bi-directional Data Pin 0 (SSI1TX in Legacy SSI Mode).
	SSI1XDAT1	124	I/O	TTL	SSI Module 1 Bi-directional Data Pin 1 (SSI1RX in Legacy SSI Mode).
	SSI1XDAT2	125	I/O	TTL	SSI Module 1 Bi-directional Data Pin 2.
	SSI1XDAT3	126	I/O	TTL	SSI Module 1 Bi-directional Data Pin 3.
	SSI2Clk	4	I/O	TTL	SSI module 2 clock.
	SSI2Fss	3	I/O	TTL	SSI module 2 frame signal.
	SSI2XDAT0	2	I/O	TTL	SSI Module 2 Bi-directional Data Pin 0 (SSI2TX in Legacy SSI Mode).
	SSI2XDAT1	1	I/O	TTL	SSI Module 2 Bi-directional Data Pin 1 (SSI2RX in Legacy SSI Mode).
	SSI2XDAT2	128	I/O	TTL	SSI Module 2 Bi-directional Data Pin 2.
	SSI2XDAT3	127	I/O	TTL	SSI Module 2 Bi-directional Data Pin 3.
	SSI3Clk	5 45	I/O	TTL	SSI module 3 clock.
	SSI3Fss	6 44	I/O	TTL	SSI module 3 frame signal.
SSI3XDAT0	11 43	I/O	TTL	SSI Module 3 Bi-directional Data Pin 0 (SSI3TX in Legacy SSI Mode).	
SSI3XDAT1	27 42	I/O	TTL	SSI Module 3 Bi-directional Data Pin 1 (SSI3RX in Legacy SSI Mode).	
SSI3XDAT2	46 118	I/O	TTL	SSI Module 3 Bi-directional Data Pin 2.	
SSI3XDAT3	119	I/O	TTL	SSI Module 3 Bi-directional Data Pin 3.	
System Control & Clocks	DIVSCLK	102	O	TTL	An optionally divided reference clock output based on a selected clock source. Note that this signal is not synchronized to the System Clock.
	NMI	128	I	TTL	Non-maskable interrupt.
	OSC0	88	I	Analog	Main oscillator crystal input or an external clock reference input.
	OSC1	89	O	Analog	Main oscillator crystal output. Leave unconnected when using a single-ended clock source.
	RST	70	I	TTL	System reset input.

Table 29-4. Signals by Function, Except for GPIO (continued)

Function	Pin Name	Pin Number	Pin Type	Buffer Type	Description
UART	U0CTS	30 74 121	I	TTL	UART module 0 Clear To Send modem flow control input signal.
	U0DCD	31 73 104	I	TTL	UART module 0 Data Carrier Detect modem status input signal.
	U0DSR	32 72 105	I	TTL	UART module 0 Data Set Ready modem output control line.
	U0DTR	103	O	TTL	UART module 0 Data Terminal Ready modem status input signal.
	U0RI	60 71	I	TTL	UART module 0 Ring Indicator modem status input signal.
	U0RTS	29 120	O	TTL	UART module 0 Request to Send modem flow control output signal.
	U0Rx	33	I	TTL	UART module 0 receive.
	U0Tx	34	O	TTL	UART module 0 transmit.
	U1CTS	104 108	I	TTL	UART module 1 Clear To Send modem flow control input signal.
	U1DCD	13 109	I	TTL	UART module 1 Data Carrier Detect modem status input signal.
	U1DSR	14 110	I	TTL	UART module 1 Data Set Ready modem output control line.
	U1DTR	12 111	O	TTL	UART module 1 Data Terminal Ready modem status input signal.
	U1RI	112 123	I	TTL	UART module 1 Ring Indicator modem status input signal.
	U1RTS	15 107	O	TTL	UART module 1 Request to Send modem flow control output line.
	U1Rx	95 102	I	TTL	UART module 1 receive.
	U1Tx	96	O	TTL	UART module 1 transmit.
	U2CTS	110 128	I	TTL	UART module 2 Clear To Send modem flow control input signal.
	U2RTS	109 127	O	TTL	UART module 2 Request to Send modem flow control output line.
	U2Rx	40 125	I	TTL	UART module 2 receive.
	U2Tx	41 126	O	TTL	UART module 2 transmit.
	U3CTS	106 112	I	TTL	UART module 3 Clear To Send modem flow control input signal.
	U3RTS	105 111	O	TTL	UART module 3 Request to Send modem flow control output line.
	U3Rx	37 116	I	TTL	UART module 3 receive.
U3Tx	38 117	O	TTL	UART module 3 transmit.	
U4CTS	21	I	TTL		

Table 29-4. Signals by Function, Except for GPIO (continued)

Function	Pin Name	Pin Number	Pin Type	Buffer Type	Description
					UART module 4 Clear To Send modem flow control input signal.
	U4RTS	20	O	TTL	UART module 4 Request to Send modem flow control output line.
	U4Rx	18 35	I	TTL	UART module 4 receive.
	U4Tx	19 36	O	TTL	UART module 4 transmit.
	U5Rx	23	I	TTL	UART module 5 receive.
	U5Tx	22	O	TTL	UART module 5 transmit.
	U6Rx	118	I	TTL	UART module 6 receive.
	U6Tx	119	O	TTL	UART module 6 transmit.
	U7Rx	25	I	TTL	UART module 7 receive.
	U7Tx	24	O	TTL	UART module 7 transmit.
USB	USB0CLK	92	O	TTL	60-MHz clock to the external PHY.
	USB0D0	81	I/O	TTL	USB data 0.
	USB0D1	82	I/O	TTL	USB data 1.
	USB0D2	83	I/O	TTL	USB data 2.
	USB0D3	84	I/O	TTL	USB data 3.
	USB0D4	85	I/O	TTL	USB data 4.
	USB0D5	86	I/O	TTL	USB data 5.
	USB0D6	106	I/O	TTL	USB data 6.
	USB0D7	105	I/O	TTL	USB data 7.
	USB0DIR	104	O	TTL	Indicates that the external PHY is able to accept data from the USB controller.
	USB0DM	93	I/O	Analog	Bidirectional differential data pin (D- per USB specification) for USB0.
	USB0DP	94	I/O	Analog	Bidirectional differential data pin (D+ per USB specification) for USB0.
	USB0EPEN	40 41 127	O	TTL	Optionally used in Host mode to control an external power source to supply power to the USB bus.
	USB0ID	95	I	Analog	This signal senses the state of the USB ID signal. The USB PHY enables an integrated pull-up, and an external element (USB connector) indicates the initial state of the USB controller (pulled down is the A side of the cable and pulled up is the B side).
	USB0NXT	103	O	TTL	Asserted by the external PHY to throttle all data types.
	USB0PFLT	41 128	I	TTL	Optionally used in Host mode by an external power source to indicate an error state by that power source.
USB0STP	91	O	TTL	Asserted by the USB controller to signal the end of a USB transmit packet or register write operation.	
USB0VBUS	96	I/O	Analog	This signal is used during the session request protocol. This signal allows the USB PHY to both sense the voltage level of VBUS, and pull up VBUS momentarily during VBUS pulsing.	

29.4 GPIO Pins and Alternate Functions

Table 29-5. GPIO Pins and Alternate Functions

IO	Pin	Analog or Special Function ^a	Digital Function (GPIOPTL PMCx Bit Field Encoding) ^b											
			1	2	3	4	5	6	7	8	11	13	14	15
PA0	33	-	U0Rx	I2C9SCL	T0CCP0	-	-	-	CAN0Rx	-	-	-	-	-
PA1	34	-	U0Tx	I2C9SDA	T0CCP1	-	-	-	CAN0Tx	-	-	-	-	-
PA2	35	-	U4Rx	I2C8SCL	T1CCP0	-	-	-	-	-	-	-	-	SSI0Clk
PA3	36	-	U4Tx	I2C8SDA	T1CCP1	-	-	-	-	-	-	-	-	SSI0Fss
PA4	37	-	U3Rx	I2C7SCL	T2CCP0	-	-	-	-	-	-	-	-	SSI0XDAT0
PA5	38	-	U3Tx	I2C7SDA	T2CCP1	-	-	-	-	-	-	-	-	SSI0XDAT1
PA6	40	-	U2Rx	I2C6SCL	T3CCP0	-	USB0EPEN	-	-	-	-	SSI0XDAT2	-	EPI0S8
PA7	41	-	U2Tx	I2C6SDA	T3CCP1	-	USB0PFLT	-	-	-	USB0EPEN	SSI0XDAT3	-	EPI0S9
PB0	95	USB0ID	U1Rx	I2C5SCL	T4CCP0	-	-	-	CAN1Rx	-	-	-	-	-
PB1	96	USB0VBUS	U1Tx	I2C5SDA	T4CCP1	-	-	-	CAN1Tx	-	-	-	-	-
PB2	91	-	-	I2C0SCL	T5CCP0	-	-	-	-	-	-	-	USB0STP	EPI0S27
PB3	92	-	-	I2C0SDA	T5CCP1	-	-	-	-	-	-	-	USB0CLK	EPI0S28
PB4	121	AIN10	U0CTS	I2C5SCL	-	-	-	-	-	-	-	-	-	SSI1Fss
PB5	120	AIN11	U0RTS	I2C5SDA	-	-	-	-	-	-	-	-	-	SSI1Clk
PC0	100	-	TCK SWCLK	-	-	-	-	-	-	-	-	-	-	-
PC1	99	-	TMS SWDIO	-	-	-	-	-	-	-	-	-	-	-
PC2	98	-	TDI	-	-	-	-	-	-	-	-	-	-	-
PC3	97	-	TDO SWO	-	-	-	-	-	-	-	-	-	-	-
PC4	25	C1-	U7Rx	-	-	-	-	-	-	-	-	-	-	EPI0S7
PC5	24	C1+	U7Tx	-	-	-	-	-	RTCCLK	-	-	-	-	EPI0S6
PC6	23	C0+	U5Rx	-	-	-	-	-	-	-	-	-	-	EPI0S5
PC7	22	C0-	U5Tx	-	-	-	-	-	-	-	-	-	-	EPI0S4
PD0	1	AIN15	-	I2C7SCL	T0CCP0	-	C0o	-	-	-	-	-	-	SSI2XDAT1
PD1	2	AIN14	-	I2C7SDA	T0CCP1	-	C1o	-	-	-	-	-	-	SSI2XDAT0
PD2	3	AIN13	-	I2C8SCL	T1CCP0	-	C2o	-	-	-	-	-	-	SSI2Fss
PD3	4	AIN12	-	I2C8SDA	T1CCP1	-	-	-	-	-	-	-	-	SSI2Clk
PD4	125	AIN7	U2Rx	-	T3CCP0	-	-	-	-	-	-	-	-	SSI1XDAT2
PD5	126	AIN6	U2Tx	-	T3CCP1	-	-	-	-	-	-	-	-	SSI1XDAT3
PD6	127	AIN5	U2RTS	-	T4CCP0	-	USB0EPEN	-	-	-	-	-	-	SSI2XDAT3
PD7	128	AIN4	U2CTS	-	T4CCP1	-	USB0PFLT	-	-	NMI	-	-	-	SSI2XDAT2
PE0	15	AIN3	U1RTS	-	-	-	-	-	-	-	-	-	-	-
PE1	14	AIN2	U1DSR	-	-	-	-	-	-	-	-	-	-	-
PE2	13	AIN1	U1DCD	-	-	-	-	-	-	-	-	-	-	-
PE3	12	AIN0	U1DTR	-	-	-	-	-	-	-	-	-	-	-
PE4	123	AIN9	U1RI	-	-	-	-	-	-	-	-	-	-	SSI1XDAT0

Table 29-5. GPIO Pins and Alternate Functions (continued)

IO	Pin	Analog or Special Function ^a	Digital Function (GPIOPCTL PMCx Bit Field Encoding) ^b											
			1	2	3	4	5	6	7	8	11	13	14	15
PE5	124	AIN8	-	-	-	-	-	-	-	-	-	-	-	SSI1XDAT1
PF0	42	-	-	-	-	-	-	ENOLED0	MOPWM0	-	-	-	-	SSI3XDAT1 TRD2
PF1	43	-	-	-	-	-	-	ENOLED2	MOPWM1	-	-	-	-	SSI3XDAT0 TRD1
PF2	44	-	-	-	-	-	-	-	MOPWM2	-	-	-	-	SSI3Fss TRD0
PF3	45	-	-	-	-	-	-	-	MOPWM3	-	-	-	-	SSI3Clk TRCLK
PF4	46	-	-	-	-	-	-	ENOLED1	MOFAULT0	-	-	-	-	SSI3XDAT2 TRD3
PG0	49	-	-	I2C1SCL	-	-	-	ENOPPS	MOPWM4	-	-	-	-	EPIOS11
PG1	50	-	-	I2C1SDA	-	-	-	-	MOPWM5	-	-	-	-	EPIOS10
PH0	29	-	U0RTS	-	-	-	-	-	-	-	-	-	-	EPIOS0
PH1	30	-	U0CTS	-	-	-	-	-	-	-	-	-	-	EPIOS1
PH2	31	-	U0DCD	-	-	-	-	-	-	-	-	-	-	EPIOS2
PH3	32	-	U0DSR	-	-	-	-	-	-	-	-	-	-	EPIOS3
PJ0	116	-	U3Rx	-	-	-	-	ENOPPS	-	-	-	-	-	-
PJ1	117	-	U3Tx	-	-	-	-	-	-	-	-	-	-	-
PK0	18	AIN16	U4Rx	-	-	-	-	-	-	-	-	-	-	EPIOS0
PK1	19	AIN17	U4Tx	-	-	-	-	-	-	-	-	-	-	EPIOS1
PK2	20	AIN18	U4RTS	-	-	-	-	-	-	-	-	-	-	EPIOS2
PK3	21	AIN19	U4CTS	-	-	-	-	-	-	-	-	-	-	EPIOS3
PK4	63	-	-	I2C3SCL	-	-	-	ENOLED0	MOPWM6	-	-	-	-	EPIOS32
PK5	62	-	-	I2C3SDA	-	-	-	ENOLED2	MOPWM7	-	-	-	-	EPIOS31
PK6	61	-	-	I2C4SCL	-	-	-	ENOLED1	MOFAULT1	-	-	-	-	EPIOS25
PK7	60	-	U0RI	I2C4SDA	-	-	-	RTCCLK	MOFAULT2	-	-	-	-	EPIOS24
PL0	81	-	-	I2C2SDA	-	-	-	-	MOFAULT3	-	-	-	-	USB0D0 EPIOS16
PL1	82	-	-	I2C2SCL	-	-	-	PhA0	-	-	-	-	-	USB0D1 EPIOS17
PL2	83	-	-	-	-	-	-	C0o	PhB0	-	-	-	-	USB0D2 EPIOS18
PL3	84	-	-	-	-	-	-	C1o	IDX0	-	-	-	-	USB0D3 EPIOS19
PL4	85	-	-	-	T0CCP0	-	-	-	-	-	-	-	-	USB0D4 EPIOS26
PL5	86	-	-	-	T0CCP1	-	-	-	-	-	-	-	-	USB0D5 EPIOS33
PL6	94	USB0DP	-	-	T1CCP0	-	-	-	-	-	-	-	-	-
PL7	93	USB0DM	-	-	T1CCP1	-	-	-	-	-	-	-	-	-
PM0	78	-	-	-	T2CCP0	-	-	-	-	-	-	-	-	EPIOS15
PM1	77	-	-	-	T2CCP1	-	-	-	-	-	-	-	-	EPIOS14
PM2	76	-	-	-	T3CCP0	-	-	-	-	-	-	-	-	EPIOS13
PM3	75	-	-	-	T3CCP1	-	-	-	-	-	-	-	-	EPIOS12
PM4	74	TMPR3	U0CTS	-	T4CCP0	-	-	-	-	-	-	-	-	-
PM5	73	TMPR2	U0DCD	-	T4CCP1	-	-	-	-	-	-	-	-	-
PM6	72	TMPR1	U0DSR	-	T5CCP0	-	-	-	-	-	-	-	-	-
PM7	71	TMPR0	U0RI	-	T5CCP1	-	-	-	-	-	-	-	-	-
PN0	107	-	U1RTS	-	-	-	-	-	-	-	-	-	-	-

Table 29-5. GPIO Pins and Alternate Functions (continued)

IO	Pin	Analog or Special Function ^a	Digital Function (GPIO PCTL PMCx Bit Field Encoding) ^b											
			1	2	3	4	5	6	7	8	11	13	14	15
PN1	108	-	U1CTS	-	-	-	-	-	-	-	-	-	-	-
PN2	109	-	U1DCD	U2RTS	-	-	-	-	-	-	-	-	-	EPI0S29
PN3	110	-	U1DSR	U2CTS	-	-	-	-	-	-	-	-	-	EPI0S30
PN4	111	-	U1DTR	U3RTS	I2C2SDA	-	-	-	-	-	-	-	-	EPI0S34
PN5	112	-	U1RI	U3CTS	I2C2SCL	-	-	-	-	-	-	-	-	EPI0S35
PP0	118	C2+	U6Rx	-	-	-	-	-	-	-	-	-	-	SSI3XDAT2
PP1	119	C2-	U6Tx	-	-	-	-	-	-	-	-	-	-	SSI3XDAT3
PP2	103	-	U0DTR	-	-	-	-	-	-	-	-	-	USB0NXT	EPI0S29
PP3	104	-	U1CTS	U0DCD	-	-	-	-	RTCCLK	-	-	-	USB0DIR	EPI0S30
PP4	105	-	U3RTS	U0DSR	-	-	-	-	-	-	-	-	USB0D7	-
PP5	106	-	U3CTS	I2C2SCL	-	-	-	-	-	-	-	-	USB0D6	-
PQ0	5	-	-	-	-	-	-	-	-	-	-	-	SSI3Clk	EPI0S20
PQ1	6	-	-	-	-	-	-	-	-	-	-	-	SSI3Fss	EPI0S21
PQ2	11	-	-	-	-	-	-	-	-	-	-	-	SSI3XDAT0	EPI0S22
PQ3	27	-	-	-	-	-	-	-	-	-	-	-	SSI3XDAT1	EPI0S23
PQ4	102	-	U1Rx	-	-	-	-	-	DIVSCLK	-	-	-	-	-

a. The TMPPrn signals are digital signals enabled and configured by the Hibernation module. All other signals listed in this column are analog signals.

b. The digital signals that are shaded gray are the power-on default values for the corresponding GPIO pin. Encodings 9, 10, and 12 are not used on this device.

29.5 Possible Pin Assignments for Alternate Functions

Table 29-6. Possible Pin Assignments for Alternate Functions

# of Possible Assignments	Alternate Function	GPIO Function
one	AIN0	PE3
	AIN1	PE2
	AIN10	PB4
	AIN11	PB5
	AIN12	PD3
	AIN13	PD2
	AIN14	PD1
	AIN15	PD0
	AIN16	PK0
	AIN17	PK1
	AIN18	PK2
	AIN19	PK3
	AIN2	PE1
	AIN3	PE0
	AIN4	PD7
	AIN5	PD6
	AIN6	PD5
	AIN7	PD4
	AIN8	PE5
	AIN9	PE4
	C0+	PC6
	C0-	PC7
	C1+	PC5
	C1-	PC4
	C2+	PP0
	C2-	PP1
	C2o	PD2
	CAN0Rx	PA0
	CAN0Tx	PA1
	CAN1Rx	PB0
	CAN1Tx	PB1
	DIVSCLK	PQ4
	EPI0S10	PG1
	EPI0S11	PG0
	EPI0S12	PM3
	EPI0S13	PM2
	EPI0S14	PM1
	EPI0S15	PM0
	EPI0S16	PL0

Table 29-6. Possible Pin Assignments for Alternate Functions (continued)

# of Possible Assignments	Alternate Function	GPIO Function
	EPI0S17	PL1
	EPI0S18	PL2
	EPI0S19	PL3
	EPI0S20	PQ0
	EPI0S21	PQ1
	EPI0S22	PQ2
	EPI0S23	PQ3
	EPI0S24	PK7
	EPI0S25	PK6
	EPI0S26	PL4
	EPI0S27	PB2
	EPI0S28	PB3
	EPI0S31	PK5
	EPI0S32	PK4
	EPI0S33	PL5
	EPI0S34	PN4
	EPI0S35	PN5
	EPI0S4	PC7
	EPI0S5	PC6
	EPI0S6	PC5
	EPI0S7	PC4
	EPI0S8	PA6
	EPI0S9	PA7
	I2C0SCL	PB2
	I2C0SDA	PB3
	I2C1SCL	PG0
	I2C1SDA	PG1
	I2C3SCL	PK4
	I2C3SDA	PK5
	I2C4SCL	PK6
	I2C4SDA	PK7
	I2C6SCL	PA6
	I2C6SDA	PA7
	I2C9SCL	PA0
	I2C9SDA	PA1
	IDX0	PL3
	M0FAULT0	PF4
	M0FAULT1	PK6
	M0FAULT2	PK7
	M0FAULT3	PL0
	M0PWM0	PF0

Table 29-6. Possible Pin Assignments for Alternate Functions (continued)

# of Possible Assignments	Alternate Function	GPIO Function
	M0PWM1	PF1
	M0PWM2	PF2
	M0PWM3	PF3
	M0PWM4	PG0
	M0PWM5	PG1
	M0PWM6	PK4
	M0PWM7	PK5
	NMI	PD7
	PhA0	PL1
	PhB0	PL2
	SSI0Clk	PA2
	SSI0Fss	PA3
	SSI0XDAT0	PA4
	SSI0XDAT1	PA5
	SSI0XDAT2	PA6
	SSI0XDAT3	PA7
	SSI1Clk	PB5
	SSI1Fss	PB4
	SSI1XDAT0	PE4
	SSI1XDAT1	PE5
	SSI1XDAT2	PD4
	SSI1XDAT3	PD5
	SSI2Clk	PD3
	SSI2Fss	PD2
	SSI2XDAT0	PD1
	SSI2XDAT1	PD0
	SSI2XDAT2	PD7
	SSI2XDAT3	PD6
	SSI3XDAT3	PP1
	SWCLK	PC0
	SWDIO	PC1
	SWO	PC3
	TCK	PC0
	TDI	PC2
	TDO	PC3
	TMPR0	PM7
	TMPR1	PM6
	TMPR2	PM5
	TMPR3	PM4
	TMS	PC1
	TRCLK	PF3

Table 29-6. Possible Pin Assignments for Alternate Functions (continued)

# of Possible Assignments	Alternate Function	GPIO Function
	TRD0	PF2
	TRD1	PF1
	TRD2	PF0
	TRD3	PF4
	U0DTR	PP2
	U0Rx	PA0
	U0Tx	PA1
	U1Tx	PB1
	U4CTS	PK3
	U4RTS	PK2
	U5Rx	PC6
	U5Tx	PC7
	U6Rx	PP0
	U6Tx	PP1
	U7Rx	PC4
	U7Tx	PC5
	USB0CLK	PB3
	USB0D0	PL0
	USB0D1	PL1
	USB0D2	PL2
	USB0D3	PL3
	USB0D4	PL4
	USB0D5	PL5
	USB0D6	PP5
	USB0D7	PP4
	USB0DIR	PP3
	USB0DM	PL7
	USB0DP	PL6
	USB0ID	PB0
	USB0NXT	PP2
	USB0STP	PB2
	USB0VBUS	PB1

Table 29-6. Possible Pin Assignments for Alternate Functions (continued)

# of Possible Assignments	Alternate Function	GPIO Function
two	C0o	PD0 PL2
	C1o	PD1 PL3
	ENOLED0	PF0 PK4
	ENOLED1	PF4 PK6
	ENOLED2	PF1 PK5
	EN0PPS	PG0 PJ0
	EPI0S0	PH0 PK0
	EPI0S1	PH1 PK1
	EPI0S2	PH2 PK2
	EPI0S29	PN2 PP2
	EPI0S3	PH3 PK3
	EPI0S30	PN3 PP3
	I2C2SDA	PL0 PN4
	I2C5SCL	PB0 PB4
	I2C5SDA	PB1 PB5
	I2C7SCL	PA4 PD0
	I2C7SDA	PA5 PD1
	I2C8SCL	PA2 PD2
	I2C8SDA	PA3 PD3
	SSI3C1k	PF3 PQ0
	SSI3Fss	PF2 PQ1
	SSI3XDAT0	PF1 PQ2
	SSI3XDAT1	PF0 PQ3
	SSI3XDAT2	PF4 PP0
	T2CCP0	PA4 PM0
	T2CCP1	PA5 PM1
	T5CCP0	PB2 PM6
	T5CCP1	PB3 PM7
	U0RI	PK7 PM7
	U0RTS	PB5 PH0
	U1CTS	PN1 PP3
	U1DCD	PE2 PN2
	U1DSR	PE1 PN3
	U1DTR	PE3 PN4
	U1RI	PE4 PN5
	U1RTS	PE0 PN0
	U1Rx	PB0 PQ4
	U2CTS	PD7 PN3
	U2RTS	PD6 PN2
	U2Rx	PA6 PD4
U2Tx	PA7 PD5	

Table 29-6. Possible Pin Assignments for Alternate Functions (continued)

# of Possible Assignments	Alternate Function	GPIO Function
	U3CTS	PN5 PP5
	U3RTS	PN4 PP4
	U3Rx	PA4 PJ0
	U3Tx	PA5 PJ1
	U4Rx	PA2 PK0
	U4Tx	PA3 PK1
	USB0PFLT	PA7 PD7
three	I2C2SCL	PL1 PN5 PP5
	RTCCLK	PC5 PK7 PP3
	T0CCP0	PA0 PD0 PL4
	T0CCP1	PA1 PD1 PL5
	T1CCP0	PA2 PD2 PL6
	T1CCP1	PA3 PD3 PL7
	T3CCP0	PA6 PD4 PM2
	T3CCP1	PA7 PD5 PM3
	T4CCP0	PB0 PD6 PM4
	T4CCP1	PB1 PD7 PM5
	U0CTS	PB4 PH1 PM4
	U0DCD	PH2 PM5 PP3
	U0DSR	PH3 PM6 PP4
	USB0EPEN	PA6 PA7 PD6

29.6 Connections for Unused Signals

Table 29-7 on page 1940 shows how to handle signals for functions that are not used in a particular system implementation for devices that are in a 128-pin TQFP package. Two options are shown in the table: an acceptable practice and a preferred practice for reduced power consumption and improved EMC characteristics. If a module is not used in a system, and its inputs are grounded, it is important that the clock to the module is never enabled by setting the corresponding bit in the **RCGCx** register.

Table 29-7. Connections for Unused Signals (128-Pin TQFP)

Function	Signal Name	Pin Number	Acceptable Practice	Preferred Practice
ADC	VREFA+	9	VDDA	VDDA
Ethernet	EN0RXIN	53	NC	NC
	EN0RXIP	54	NC	NC
	EN0TXON	56	NC	NC
	EN0TXOP	57	NC	NC
	RBIAS	59	Connect to ground through 4.87K resistor	NC ^a
GPIO	PA1(UART0TX)	34	NC	GND ^b
	PA4(SSIOXDAT0)	37	NC	GND ^c
	All unused GPIOs	-	NC	GND

Table 29-7. Connections for Unused Signals (128-Pin TQFP) (continued)

Function	Signal Name	Pin Number	Acceptable Practice	Preferred Practice
Hibernate	$\overline{\text{HIB}}$	65	NC	NC
	VBAT	68	NC	VDD
	$\overline{\text{WAKE}}$	64	NC	GND
	XOSC0	66	NC	GND
	XOSC1	67	NC	NC
No Connects	NC	See NC pin numbers in Table 29-3 on page 1909	NC	NC
System Control	OSC0	88	NC	GND
	OSC1	89	NC	NC
	$\overline{\text{RST}}$	70	VDD	Pull up as shown in Figure 5-1 on page 231
USB	USB0DM / PL7	93	NC	Pull-down to GND with 1K resistor ^d
	USB0DP / PL6	94	NC	Pull-down to GND with 1K resistor ^d

- The internal Ethernet PHY should not be enabled when RBIAS is not connected. The ROM boot loader will enable the internal Ethernet Phy if no code is present in the flash and a 24-25Mhz crystal is attached to the OSC0/1 pins.
- PA1 (UART0TX) may be enabled as an output by the ROM boot loader if no code is present in the flash and PA0 (UART0RX) receives a valid boot signature. Ensure that this condition will not occur if PA1 is to be connected directly to GND.
- PA4 (SSI0XDAT0) may be enabled as an output by the ROM boot loader if no code is present in the flash and the SSI0x (PA2, PA3, PA5) receives a valid boot signature. Ensure that this condition will not occur if PA4 is to be connected directly to GND.
- The ROM boot loader may configure these pins as USB pins if no code is present in the flash therefore they should not be directly connected to ground.

30 Electrical Characteristics

30.1 Maximum Ratings

The maximum ratings are the limits to which the device can be subjected without permanently damaging the device. Device reliability may be adversely affected by exposure to absolute-maximum ratings for extended periods.

Note: The device is not guaranteed to operate properly at the maximum ratings.

Table 30-1. Absolute Maximum Ratings

Parameter	Parameter Name ^a	Value		Unit
		Min	Max	
V _{DD}	V _{DD} supply voltage	0	4	V
V _{DDA}	V _{DDA} supply voltage	0	4	V
V _{BAT}	V _{BAT} battery supply voltage	0	4	V
V _{BATRMP}	V _{BAT} battery supply voltage ramp time	0	0.7	V/μs
V _{IN_GPIO}	Input voltage ^b	-0.3	4	V
I _{GPIO MAX}	Maximum current per output pin	-	64	mA
T _S	Unpowered storage temperature range	-65	150	°C
T _{JMAX}	Maximum junction temperature	-	125	°C

a. Voltages are measured with respect to GND.

b. Applies to static and dynamic signals including overshoot.

Important: This device contains circuitry to protect the I/Os against damage due to high-static voltages; however, it is advised that normal precautions be taken to avoid application of any voltage higher than maximum-rated voltages to this high-impedance circuit. Reliability of operation is enhanced if unused inputs are connected to an appropriate logic voltage level (see “Connections for Unused Signals” on page 1940).

Table 30-2. ESD Absolute Maximum Ratings

Parameter	Parameter Name	Min	Nom	Max	Unit
Component-Level ESD Stress Voltage ^a	V _{ESDHBM} ^b	-	-	2.0	kV
	V _{ESDCDM} ^c	-	-	500	V

a. Electrostatic discharge (ESD) is used to measure device sensitivity/immunity to damage caused by electrostatic discharges in device.

b. All pins are HBM compliant to 2 kV for all combinations as per JESD22-A114F, except for the following stress combinations:

- The Ethernet EN0RXIN, EN0TX0N, EN0RXIP, and EN0TXOP pins to each other.
- The GPIO pins PM4, PM5, PM6, and PM7 to other pins.

These exceptions are compliant to 500 V and do not require any special handling beyond typical ESD control procedures during assembly operations per JEDEC publication JEP155. Note that these pins do meet the 500 V CDM specification.

c. Level listed is the passing level per EIA-JEDEC JESD22-C101E. JEDEC document JEP157 states that 250 V CDM allows safe manufacturing with a standard ESD control process.

30.2 Operating Characteristics

Table 30-3. Temperature Characteristics

Characteristic	Symbol	Value	Unit
Ambient operating temperature range	T_A	-40 to 85 (industrial temperature part) -40 to 105 (extended temperature part)	°C
Junction operating temperature range	T_J	-40 to 105 (industrial temperature part) -40 to 125 (extended temperature part)	°C

Table 30-4. 128-pin TQFP Power Dissipation^{ab}

Parameter	Parameter Name	T_A	T_J	Min	Max	Unit
P_{DI}	Industrial temperature device power dissipation	85 °C (industrial temperature part)	125 °C (industrial temperature part)	-	904	mW
P_{DE}	Extended temperature device power dissipation	105 °C (extended temperature part)	125 °C (extended temperature part)	-	452	mW

- a. If the device exceeds the power dissipation value shown, then modifications such as heat sinks or fans must be used to conform to the limits shown.
- b. A larger power dissipation allowance can be achieved by lowering T_A as long as T_{JMAX} shown in Table 30-1 on page 1942 is not exceeded.

Table 30-5. Thermal Characteristics^a

Characteristic	Symbol	Value	Unit
Thermal resistance (junction to ambient) ^b	Θ_{JA}	44.2	°C/W
Thermal resistance (junction to board) ^b	Θ_{JB}	22.4	°C/W
Thermal resistance (junction to case) ^b	Θ_{JC}	6.8	°C/W
Thermal metric (junction to top of package)	Ψ_{JT}	0.2	°C/W
Thermal metric (junction to board)	Ψ_{JB}	22.1	°C/W
Junction temperature formula	T_J	$T_C + (P \cdot \Psi_{JT})^c$ $T_{PCB} + (P \cdot \Psi_{JB})^d$ $T_A + (P \cdot \Theta_{JA})^e$ $T_B + (P \cdot \Theta_{JB})^{fg}$	°C

- a. For more details about thermal metrics and definitions, see the *Semiconductor and IC Package Thermal Metrics Application Report* (literature number [SPRA953](#)).
- b. Junction to ambient thermal resistance (Θ_{JA}), junction to board thermal resistance (Θ_{JB}), and junction to case thermal resistance (Θ_{JC}) numbers are determined by a package simulator.
- c. T_C is the case temperature and P is the device power consumption.
- d. T_{PCB} is the temperature of the board acquired by following the steps listed in the EAI/JESD 51-8 standard summarized in the *Semiconductor and IC Package Thermal Metrics Application Report* (literature number [SPRA953](#)). P is the device power consumption.
- e. Because Θ_{JA} is highly variable and based on factors such as board design, chip/pad size, altitude, and external ambient temperature, it is recommended that equations containing Ψ_{JT} and Ψ_{JB} be used for best results.
- f. T_B is temperature of the board.
- g. Θ_{JB} is not a pure reflection of the internal resistance of the package because it includes the resistance of the testing board and environment. It is recommended that equations containing Ψ_{JT} and Ψ_{JB} be used for best results.

30.3 Recommended Operating Conditions

The following sections describe the recommended DC operating conditions and GPIO operating characteristics for the device.

30.3.1 DC Operating Conditions

Table 30-6. Recommended DC Operating Conditions

Parameter	Parameter Name	Min	Nom	Max	Unit
V _{DD}	V _{DD} supply voltage	2.97	3.3	3.63	V
V _{DDA} ^a	V _{DDA} supply voltage	2.97	3.3	3.63	V
V _{DDC}	V _{DDC} supply voltage, Run mode	1.14	1.2	1.32	V
V _{DDCDS}	V _{DDC} supply voltage, Deep-Sleep mode	0.85	-	0.95	V

a. To ensure proper operation, V_{DDA} must be powered up before V_{DD} if sourced from different supplies, or connected to the same supply as V_{DD}. There is not a restriction on order for powering off.

30.3.2 Recommended GPIO Operating Characteristics

Two types of pads are provided on the device:

- Fast GPIO pads: These pads provide variable, programmable drive strength and optimized voltage output levels.
- Slow GPIO pads: These pads provide 2-mA drive strength and are designed to be sensitive to voltage inputs. The following GPIOs port pins are designed with Slow GPIO Pads:
 - PJ1

All other GPIOs have a fast GPIO pad-type.

Note: Port pins **PL6** and **PL7** operate as Fast GPIO pads, but have 4-mA drive capability only. GPIO register controls for drive strength, slew rate and open drain have no effect on these pins. The registers which have no effect are as follows: **GPIODR2R**, **GPIODR4R**, **GPIODR8R**, **GPIODR12R**, **GPIOSLR**, and **GPIOODR**.

Note: Port pins **PM[7:4]** operate as Fast GPIO pads but support only 2-, 4-, 6-, and 8-mA drive capability. 10- and 12-mA drive are not supported. All standard GPIO register controls, except for the **GPIODR12R** register, apply to these port pins.

Table 30-7 on page 1944 detail the GPIO operating conditions for these two different pad types.

Table 30-7. Recommended FAST GPIO Pad Operating Conditions

Parameter	Parameter Name	Min	Nom	Max	Unit
V _{IH}	Fast GPIO high-level input voltage	0.65 * V _{DD}	-	4	V
I _{IH}	Fast GPIO high-level input current ^a	-	-	300	nA
V _{IL}	Fast GPIO low-level input voltage	0	-	0.35 * V _{DD}	V
I _{IL}	Fast GPIO low-level input current ^a	-	-	-200	nA
V _{HYS}	Fast GPIO Input Hysteresis	0.49	-	-	V
V _{OH}	Fast GPIO High-level output voltage	2.4	-	-	V
V _{OL}	Fast GPIO Low-level output voltage	-	-	0.40	V

Table 30-7. Recommended FAST GPIO Pad Operating Conditions (continued)

Parameter	Parameter Name	Min	Nom	Max	Unit
I_{OH}	Fast GPIO High-level source current, $V_{OH}=2.4\text{ V}^b$				
	2-mA Drive	2.0	-	-	mA
	4-mA Drive	4.0	-	-	mA
	8-mA Drive	8.0	-	-	mA
	10-mA Drive	10.0	-	-	mA
	12-mA Drive	12.0	-	-	mA
I_{OL}	Fast GPIO Low-level sink current, $V_{OL}=0.4\text{ V}^b$				
	2-mA Drive	2.0	-	-	mA
	4-mA Drive	4.0	-	-	mA
	8-mA Drive	8.0	-	-	mA
	10-mA Drive	10.0	-	-	mA
	12-mA Drive	12.0	-	-	mA
	12-mA Drive overdriven to 18-mA	18.0	-	-	mA

a. Output/pull-up/pull-down disabled; only input enabled

b. I_O specifications reflect the maximum current where the corresponding output voltage meets the V_{OH}/V_{OL} thresholds. I_O current can exceed these limits (subject to absolute maximum ratings).

Table 30-8. Recommended Slow GPIO Pad Operating Conditions

Parameter	Parameter Name	Min	Nom	Max	Unit
V_{IH}	Slow GPIO high-level input voltage	$0.65 * V_{DD}$	-	4	V
I_{IH}	Slow GPIO high-level input current ^a	-	-	4.1	nA
V_{IL}	Slow GPIO low-level input voltage	0	-	$0.35 * V_{DD}$	V
I_{IL}	Slow GPIO low-level input current ^a	-	-	-1	nA
V_{HYS}	Slow GPIO Input Hysteresis	0.49	-	-	V
V_{OH}	Slow GPIO High-level output voltage	2.4	-	-	V
V_{OL}	Slow GPIO Low-level output voltage	-	-	0.4	V
I_{OH}	High-level source current, $V_{OH}=2.4\text{ V}^b$				
	2-mA Drive	2.0	-	-	mA
I_{OL}	Low-level sink current, $V_{OL}=0.4\text{ V}^b$				
	2-mA Drive	2.0	-	-	mA

a. Output/pull-up/pull-down disabled; only input enabled.

b. I_O specifications reflect the maximum current where the corresponding output voltage meets the V_{OH}/V_{OL} thresholds. I_O current can exceed these limits (subject to absolute maximum ratings).

30.3.2.1 GPIO Current Restrictions

Table 30-9. GPIO Current Restrictions^a

Parameter	Parameter Name	Min	Nom	Max	Unit
I_{MAXL}	Cumulative maximum GPIO current per side, left ^b	-	-	112	mA
I_{MAXB}	Cumulative maximum GPIO current per side, bottom ^b	-	-	97.6	mA
I_{MAXR}	Cumulative maximum GPIO current per side, right ^b	-	-	112	mA

Table 30-9. GPIO Current Restrictions (continued)

Parameter	Parameter Name	Min	Nom	Max	Unit
I_{MAXT}	Cumulative maximum GPIO current per side, top ^b	-	-	80	mA

a. Based on design simulations, not tested in production.

b. Sum of sink and source current for GPIOs as shown in Table 30-10 on page 1946.

Table 30-10. Maximum GPIO Package Side Assignments

Side	GPIOs
Left	PC[4-7], PD[0-3], PQ[0-3], PE[0-3], PK[0-3], PN[4-5], PH[0-3]
Bottom	PA[0-7], PF[0-4], PG[0-1], PK[4-7]
Right	PM[0-7], PL[0-7], PB[0-3]
Top	PC[0-3], PQ[4], PP[0-5], PN[0-5], PJ[0-1], PB[4-5], PE[4-5], PD[4-7]

I/O Reliability

For typical continuous drive applications, I/O pins configured between 2 mA and 12 mA and operating at -40 to 85°C, meet the standard 10-year lifetime reliability. If a continuous current sink of 18 mA is required, then operation is limited to 0 to 75°C in order to meet the standard 10-year reliability.

At 105°C, I/O configured for continuous drive meet the standard 2.5 year lifetime reliability.

In typical switching applications (40% switch rate) operating at -40 to 85°C, all I/O configurations except 2 mA meet the standard 10-year lifetime reliability with 50-pF loading. By limiting the capacitive loading to 20 pF for an I/O configured to 2 mA, the 10-year lifetime reliability can be met at -40 to 85°C.

In typical switching applications (40% switch rate) operating at 105°C, all I/O configurations except 2 mA meet the standard 2.5-year lifetime reliability. By reducing the capacitive loading to 20 pF with a typical switching rate at 105°C, a 2-mA I/O configuration meets a 2.5 year lifetime reliability.

30.4 Load Conditions

Table 30-11 on page 1947 contains the load conditions used for timing measurements.

Figure 30-1. Load Conditions

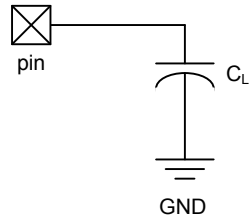

Table 30-11. Load Conditions

Signals	Load Value (C_L)
EPI0S[35:0] SDRAM interface	30 pF
EPI0S[35:0] General-Purpose interface	
EPI0S[35:0] Host-Bus interface	
EPI0S[35:0] PSRAM interface	40 pF
All other digital I/O signals	50 pF

30.5 JTAG and Boundary Scan

Table 30-12. JTAG Characteristics

Parameter No.	Parameter	Parameter Name	Min	Nom	Max	Unit
J1	F_{TCK}	TCK operational clock frequency ^a	0	-	10	MHz
J2	T_{TCK}	TCK operational clock period	100	-	-	ns
J3	T_{TCK_LOW}	TCK clock Low time	-	$t_{TCK}/2$	-	ns
J4	T_{TCK_HIGH}	TCK clock High time	-	$t_{TCK}/2$	-	ns
J5	T_{TCK_R}	TCK rise time	0	-	10	ns
J6	T_{TCK_F}	TCK fall time	0	-	10	ns
J7	T_{TMS_SU}	TMS setup time to TCK rise	8	-	-	ns
J8	T_{TMS_HLD}	TMS hold time from TCK rise	4	-	-	ns
J9	T_{TDI_SU}	TDI setup time to TCK rise	18	-	-	ns
J10	T_{TDI_HLD}	TDI hold time from TCK rise	4	-	-	ns
J11	T_{TDO_ZDV}	TCK fall to Data Valid from High-Z, 2-mA drive	-	13	35	ns
		TCK fall to Data Valid from High-Z, 4-mA drive		9	26	ns
		TCK fall to Data Valid from High-Z, 8-mA drive		8	26	ns
		TCK fall to Data Valid from High-Z, 8-mA drive with slew rate control		10	29	ns
		TCK fall to Data Valid from High-Z, 10-mA drive		11	13	ns
		TCK fall to Data Valid from High-Z, 12-mA drive		11	14	ns
J12	T_{TDO_DV}	TCK fall to Data Valid from Data Valid, 2-mA drive	-	14	20	ns
		TCK fall to Data Valid from Data Valid, 4-mA drive		10	26	ns
		TCK fall to Data Valid from Data Valid, 8-mA drive		8	21	ns
		TCK fall to Data Valid from Data Valid, 8-mA drive with slew rate control		10	26	ns
		TCK fall to Data Valid from Data Valid, 10-mA drive		12	14	ns
		TCK fall to Data Valid from Data Valid, 12-mA drive		12	15	ns
J13	T_{TDO_DVZ}	TCK fall to High-Z from Data Valid, 2-mA drive	-	7	16	ns
		TCK fall to High-Z from Data Valid, 4-mA drive		7	16	ns
		TCK fall to High-Z from Data Valid, 8-mA drive		7	16	ns
		TCK fall to High-Z from Data Valid, 8-mA drive with slew rate control		8	19	ns
		TCK fall to High-Z from Data Valid, 10-mA drive		20	22	ns
		TCK fall to High-Z from Data Valid, 12-mA drive		20	25	ns

a. A ratio of at least 8:1 must be kept between the system clock and TCK.

Figure 30-2. JTAG Test Clock Input Timing

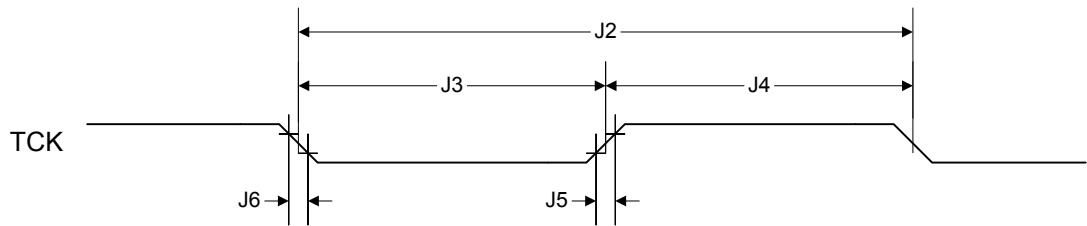
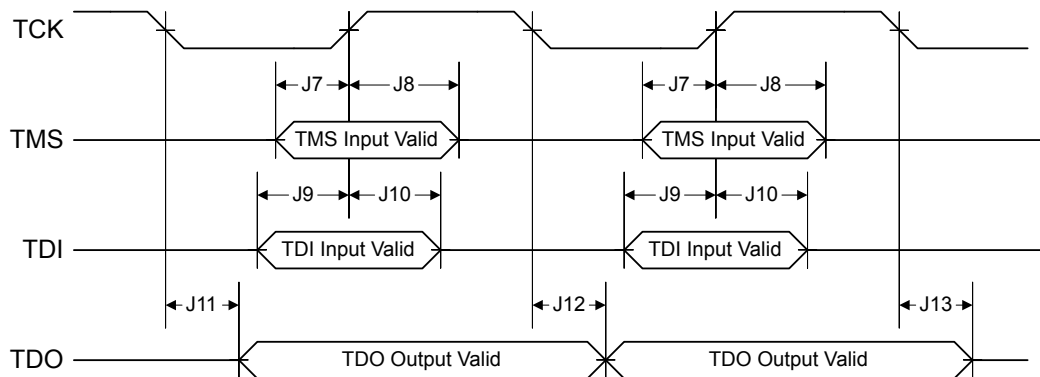

Figure 30-3. JTAG Test Access Port (TAP) Timing



30.6 Power and Brown-Out

Table 30-13. Power and Brown-Out Levels

Parameter No.	Parameter	Parameter Name	Min	Nom	Max	Unit
P1	T_{VDDA_RISE}	Analog Supply voltage (V_{DDA}) rise time	-	-	∞	μs
P2	T_{VDD_RISE}	I/O Supply voltage (V_{DD}) rise time	-	-	∞	μs
P3	$T_{VDDC_RISE}^a$	Core Supply Voltage (V_{DDC}) rise time	10	-	150	μs
P4	V_{POR}	Power-On Reset Threshold (Rising Edge)	1.98	2.35	2.72	V
		Power-On Reset Threshold (Falling Edge)	1.84	2.20	2.56	V
		Power-On Reset Hysteresis	0.06	0.15	0.24	V
P5	V_{DDA_POK}	V_{DDA} Power-OK Threshold (Rising Edge)	2.67	2.82	2.97	V
P6	V_{DDA_BOR0}	V_{DDA} Brown-Out Reset Threshold	2.71	2.80	2.89	V
P7	V_{DD_POK}	V_{DD} Power-OK Threshold (Rising Edge)	2.65	2.80	2.90	V
		V_{DD} Power-OK Threshold (Falling Edge)	2.67	2.76	2.85	V
P8	V_{DD_BOR0}	V_{DD} Brown-Out Reset Threshold	2.77	2.86	2.95	V
P9	V_{DDC_POK}	V_{DDC} Power-OK Threshold (Rising Edge)	0.85	0.95	1.10	V
		V_{DDC} Power-OK Threshold (Falling Edge)	0.71	0.80	0.85	V

a. The MIN and MAX values are based on an external filter capacitor load within the range of C_{LDO} . Please refer to "On-Chip Low Drop-Out (LDO) Regulator" on page 1958 for the C_{LDO} value.

30.6.1 V_{DDA} Levels

The V_{DDA} supply has three monitors:

- Power-On Reset (POR)
- Power-OK (POK)
- Brown Out Reset (BOR)

The POR monitor is used to keep the analog circuitry in reset until the V_{DDA} supply has reached the correct range for the analog circuitry to begin operating. The POK monitor is used to keep the digital circuitry in reset until the V_{DDA} power supply is at an acceptable operational level. The digital reset is only released when the Power-On Reset has deasserted and all of the Power-OK monitors for each of the supplies indicate that power levels are in operational ranges. The BOR monitor is used to generate a reset to the device or assert an interrupt if the V_{DDA} supply drops below its operational range.

Note: V_{DDA} BOR and V_{DD} BOR events are a combined BOR to the system logic, such that if either BOR event occurs, the following bits are affected:

- **BORRIS** bit in the **Raw Interrupt Status (RIS)** register, System Control offset 0x050. See page 268.
- **BORMIS** bit in the **Masked Interrupt Status and Clear (MISC)** register, System Control offset 0x058. This bit is set only if the **BORIM** bit in the **Interrupt Mask Control (IMC)** register has been set. See page 270 and page 272.

- BOR bit in the **Reset Cause (RESC)** register, System Control offset 0x05C. This bit is set only if either of the BOR events have been configured to initiate a reset. See page 274.

In addition, the following bits control both BOR events:

- BORIM bit in the **Interrupt Mask Control (IMC)** register, System Control offset 0x054.
- VDDA_UBOR0 and VDD_UBOR0 bits in the **Power-Temperature Cause (PWRTC)** register.

Please refer to “System Control” on page 227 for more information on how to configure these registers.

Figure 30-4 on page 1951 shows the relationship between V_{DDA} , POK, POR and a BOR event.

Figure 30-4. Power and Brown-Out Assertions vs V_{DDA} Levels

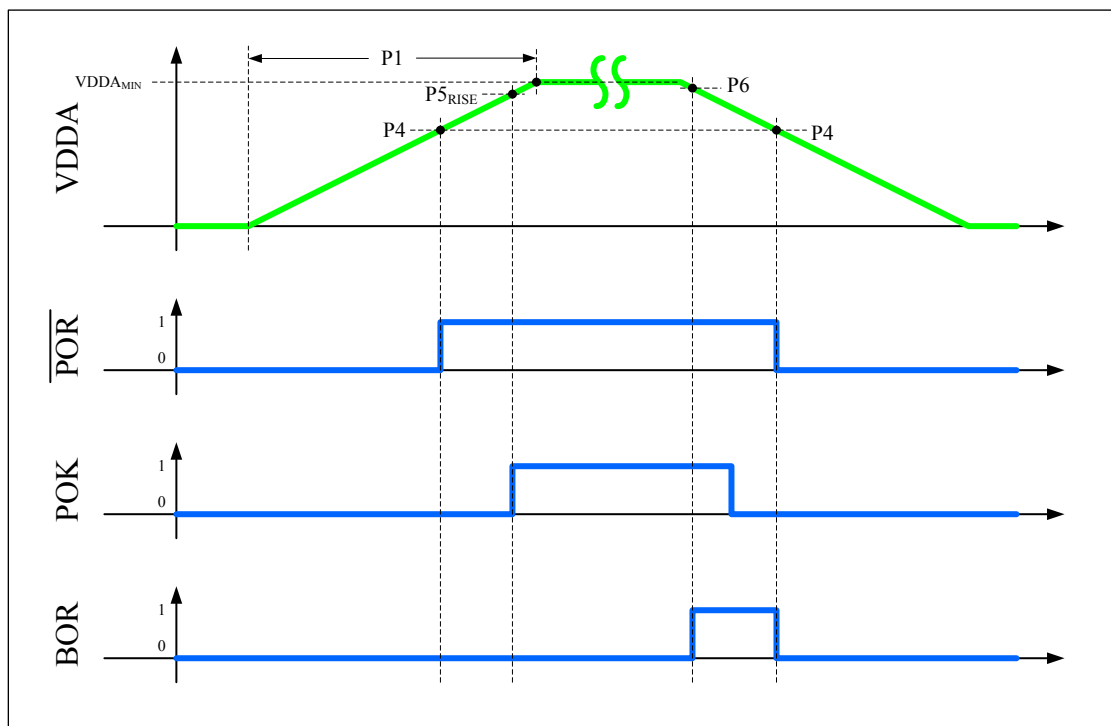

30.6.2 V_{DD} Levels

The V_{DD} supply has two monitors:

- Power-OK (POK)
- Brown Out Reset (BOR)

The POK monitor is used to keep the digital circuitry in reset until the V_{DD} power supply is at an acceptable operational level. The digital reset is only released when the Power-On Reset has deasserted and all of the Power-OK monitors for each of the supplies indicate that power levels are

in operational ranges. The BOR monitor is used to generate a reset to the device or assert an interrupt if the V_{DD} supply drops below its operational range.

Note: V_{DDA} BOR and V_{DD} BOR events are a combined BOR to the system logic, such that if either BOR event occurs, the following bits are affected:

- BORRIS bit in the **Raw Interrupt Status (RIS)** register, System Control offset 0x050. See page 268.
- BORMIS bit in the **Masked Interrupt Status and Clear (MISC)** register, System Control offset 0x058. This bit is set only if the BORIM bit in the **Interrupt Mask Control (IMC)** register has been set. See page 270 and page 272.
- BOR bit in the **Reset Cause (RESC)** register, System Control offset 0x05C. This bit is set only if either of the BOR events have been configured to initiate a reset. See page 274.

In addition, the following bits control both BOR events:

- BORIM bit in the **Interrupt Mask Control (IMC)** register, System Control offset 0x054.
- VDDA_UBOR0 and VDD_UBOR0 bits in the **Power-Temperature Cause (PWRTC)** register.

Please refer to “System Control” on page 227 for more information on how to configure these registers.

Figure 30-5 on page 1952 shows the relationship between V_{DD} , POK, POR and a BOR event.

Figure 30-5. Power and Brown-Out Assertions vs V_{DD} Levels

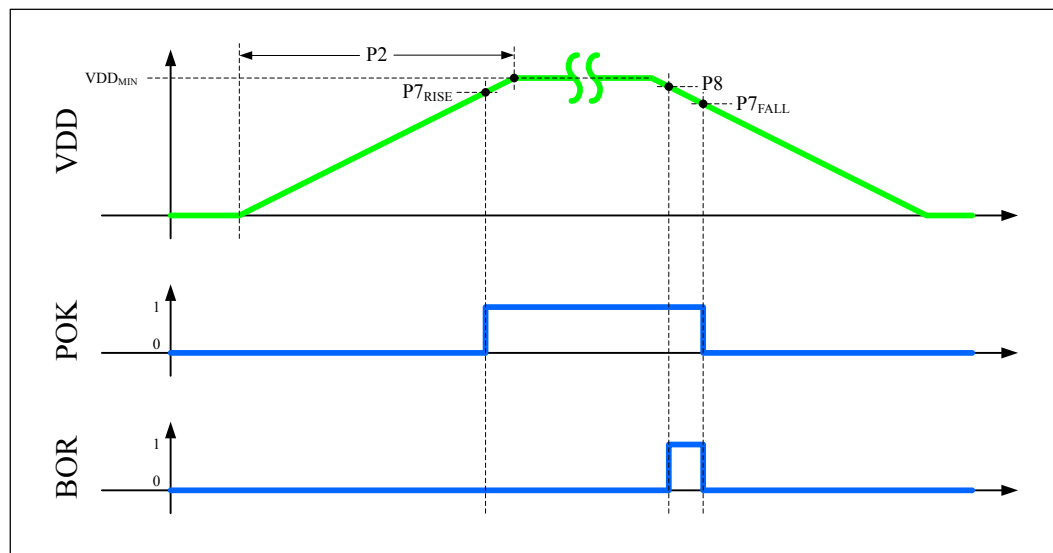

30.6.3 V_{DDC} Levels

The V_{DDC} supply has one monitor, the Power-OK (POK). The POK monitor is used to keep the digital circuitry in reset until the V_{DDC} power supply is at an acceptable operational level. The digital reset is only released when the Power-On Reset has deasserted and all of the Power-OK monitors for each of the supplies indicate that power levels are in operational ranges. Figure 30-6 on page 1953 shows the relationship between POK and V_{DDC} .

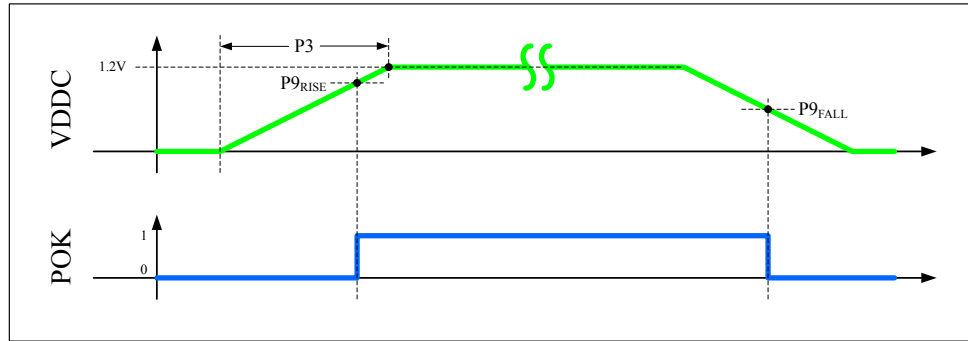
Figure 30-6. POK Assertion vs V_{DDC} 

30.6.4 Response

30.6.4.1 V_{DD} Glitch Response

Figure 30-7 on page 1953 shows the response of the BOR and the POR circuit to glitches on the VDD supply.

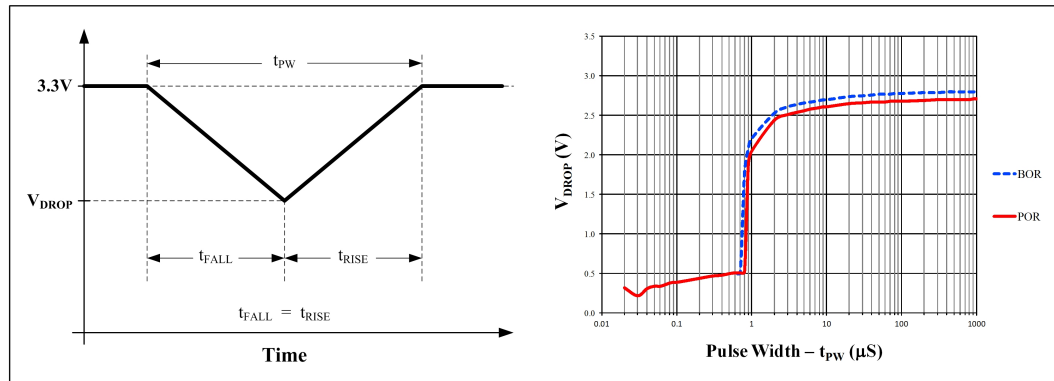
Figure 30-7. POR-BOR V_{DD} Glitch Response

30.6.4.2 V_{DD} Droop Response

Figure 30-8 on page 1954 shows the response of the BOR and the POR monitors to a drop on the VDD supply.

Figure 30-8. POR-BOR V_{DD} Droop Response

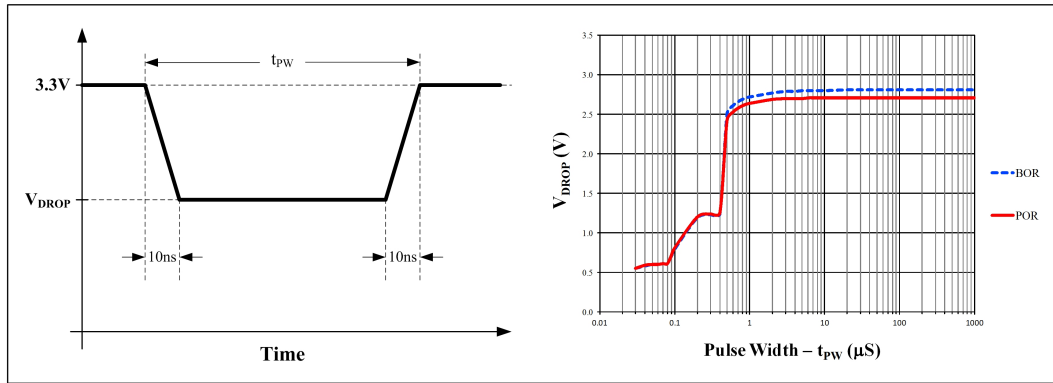

30.7 Reset

Table 30-14. Reset Characteristics^a

Parameter No.	Parameter	Parameter Name	Min	Nom	Max	Unit
R1	$T_{DPORDLY}^b$	Digital POR to Internal Reset assertion delay ^c	0.44	-	126	μs
R2	T_{IRTOU}^{bd}	Standard Internal Reset time	-	14	16	ms
		Internal Reset time with recovery code repair (program or erase) ^e	24.4	-	6400 ^f	ms
R3	$T_{BORODLY}^b$	BOR0 to Internal Reset assertion delay ^c	0.44	-	125	μs
R4	T_{RSTMIN}	Minimum $\overline{\text{RST}}$ pulse width	-	0.25 ^g /100 ^h	-	μs
R5	$T_{IRHWDLY}$	$\overline{\text{RST}}$ to Internal Reset assertion delay	-	0.85	-	μs
R6	T_{IRSWR}^b	Internal reset timeout after software-initiated system reset	-	2.44	-	μs
R7	T_{IRWDR}^b	Internal reset timeout after Watchdog reset	-	2.44	-	μs
R8	T_{IRMFR}^b	Internal reset timeout after MOSC failure reset	-	2.44	-	μs

- a. Minimum timings are for reset assertion using PIOSC as a clock source. Maximum timings are for reset assertion using LFIOSC in Deep-Sleep Operation.
- b. These values are based on simulation.
- c. Timing values are dependent on the V_{DD} power-down ramp rate.
- d. This is the delay from the time POR is released until the reset vector is fetched.
- e. This parameter applies only in situations where a power-loss or brown-out event occurs during an EEPROM program or erase operation, and EEPROM needs to be repaired (which is a rare case). For all other sequences, there is no impact to normal Power-On Reset (POR) timing. This delay is in addition to other POR delays.
- f. This value represents the maximum internal reset time when the EEPROM reaches its endurance limit.
- g. Standard operation.
- h. Deep-Sleep operation with PIOSC powered down.

Figure 30-9. Digital Power-On Reset Timing

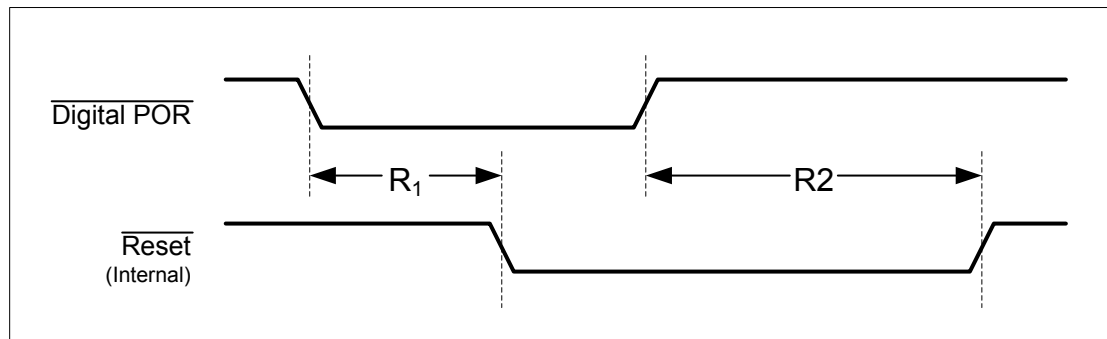

The digital Power-On Reset is only released when the analog Power-On Reset has deasserted and all of the Power-OK monitors for each of the supplies indicate that power levels are in operational ranges.

Figure 30-10. Brown-Out Reset Timing



Figure 30-11. External Reset Timing (\overline{RST})



Figure 30-12. Software Reset Timing



Figure 30-13. Watchdog Reset Timing

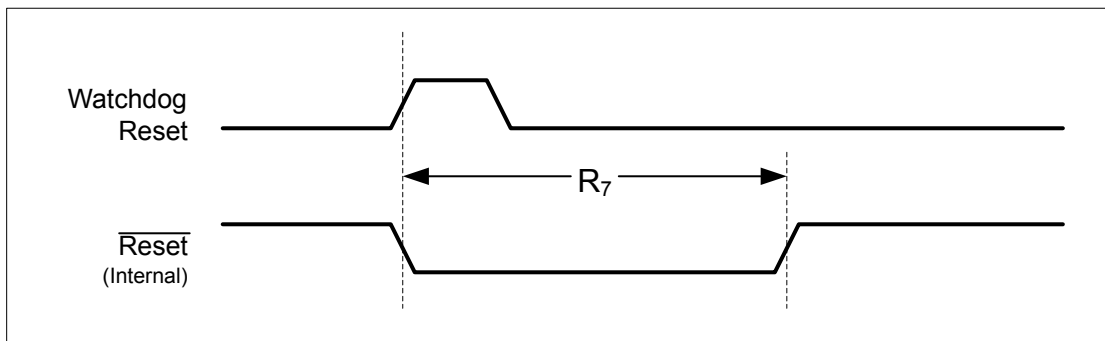

Figure 30-14. MOSC Failure Reset Timing



30.8 On-Chip Low Drop-Out (LDO) Regulator

Table 30-15. LDO Regulator Characteristics

Parameter	Parameter Name	Min	Nom	Max	Unit
C_{LDO}	External filter capacitor size for internal power supply ^a	2.5	-	4.0	μF
ESR	Filter capacitor equivalent series resistance	0	-	100	$\text{m}\Omega$
ESL	Filter capacitor equivalent series inductance	-	-	0.5	nH
V_{LDO}	LDO output voltage, Run mode	1.13	1.2	1.27	V
I_{INRUSH}	Inrush current	50	-	250	mA

a. The capacitor should be connected as close as possible to pin 115.

30.9 Clocks

The following sections provide specifications on the various clock sources and mode.

30.9.1 PLL Specifications

The following tables provide specifications for using the PLL.

Note: If the integrated Ethernet PHY is used in this device, then F_{REF_XTAL} and F_{REF_EXT} are required to be 25 MHz.

Table 30-16. Phase Locked Loop (PLL) Characteristics

Parameter	Parameter Name	Min	Nom	Max	Unit
F_{REF_XTAL}	Crystal reference	5	-	25	MHz
F_{REF_EXT}	External clock reference	5	-	25	MHz
F_{PLL}	PLL VCO frequency at 1.2V ^a	-	-	480	MHz
F_{PLLS}	PLL VCO frequency at 0.9V ^b	-	-	480	MHz
T_{READY}	PLL lock time (enabling the PLL) when PLL is transitioning from power down to power up	-	-	512 * (reference clock period)	μs
	PLL lock time when the PLL VCO frequency is changed (PLL is already enabled)	-	-	128 * (reference clock period)	μs
	PLL lock time, changing the OSCSRC between MOSC and PIOSC	-	-	128 * (reference clock period)	μs

a. PLL frequency is manually calculated using the values in the PLLFREQ0 and PLLFREQ1 registers.

b. If the LDO is dropped to 0.9V, the system must be run 1/4 of the maximum frequency at most. The Q value in the PLLFREQ1 register must be set to 0x3 rather than using the PSYSDIV field in the RSCLKCFG register for the divisor.

30.9.1.1 PLL Configuration

The PLL is disabled by default during power-on reset and is enabled later by software if required. Software specifies the output divisor to set the system clock frequency and enables the PLL to drive the output. The PLL is controlled using the PLLFREQ0, PLLFREQ1 and PLLSTAT registers. Changes made to these registers do not become active until after the NEWFREQ bit in the RSCLKCFG register is enabled.

The clock source for the main PLL is selected by configuring the PLLSRC field in the Run and Sleep Clock Configuration (RSCLKCFG) register.

The PLL allows for the generation of system clock frequencies in excess of the reference clock provided. The reference clocks for the PLL are the PIOSC and the MOSC. The PLL is controlled by two registers, PLLFREQ0 and PLLFREQ1. The PLL VCO frequency (f_{VCO}) is determined through the following calculation:

$$f_{VCO} = f_{IN} * MDIV$$

where

$$f_{IN} = f_{XTAL} / (Q+1)(N+1) \text{ or } f_{PIOSC} / (Q+1)(N+1)$$

$$MDIV = MINT + (MFRAC / 1024)$$

The Q and N values are programmed in the PLLFREQ1 register. Note that to reduce jitter, MFRAC should be programmed to 0x0.

When the PLL is active, the system clock frequency (SysClk) is calculated using the following equation:

$$\text{SysClk} = f_{\text{VCO}} / (\text{PSYSDIV} + 1)$$

The PLL system divisor factor (PSYSDIV) determines the value of the system clock. Table 5-6 on page 244 shows how the system divisor encodings affect the system clock frequency when the $f_{\text{VCO}} = 480$ MHz.

Table 30-17. System Divisor Factors for $f_{\text{VCO}}=480$ MHz

System Clock (SYSCLK) (MHz)	f_{VCO} (MHz)= 480 MHz
	System Divisors (PSYSDIV +1) ^a
120	4
60	8
48	10
30	16
24	20
12	40
6	80

a. The use of non-integer divisors introduce additional jitter which may affect interface performance.

If the main oscillator provides the clock reference to the PLL, the translation provided by hardware and used to program the PLL is available for software in the **PLL Frequency n (PLLFREQn)** registers (see page 299). The internal translation provides a translation within $\pm 1\%$ of the targeted PLL VCO frequency. Table 5-7 on page 245 shows the actual PLL frequency and error for a given crystal choice.

Table 5-7 on page 245 provides examples of the programming expected for the **PLLREQ0** and **PLLREQ1** registers. The first column specifies the input crystal frequency and the last column displays the PLL frequency given the values of MINT and N, when Q=0.

Table 30-18. Actual PLL Frequency^a

Crystal Frequency (MHz)	MINT (Decimal Value)	MINT (Hexadecimal Value)	N	Reference Frequency (MHz) ^b	PLL Frequency (MHz)
5	64	0x40	0x0	5	320
6	160	0x35	0x2	2	320
8	40	0x28	0x0	8	320
10	32	0x20	0x0	10	320
12	80	0x50	0x2	4	320
16	20	0x14	0x0	16	320
18	160	0xA0	0x8	2	320
20	16	0x10	0x0	20	320
24	40	0x28	0x2	8	320
25	64	0x40	0x4	5	320
5	96	0x60	0x0	5	480
6	80	0x50	0x0	6	480
8	60	0x3C	0x0	8	480

Table 30-18. Actual PLL Frequency (continued)

Crystal Frequency (MHz)	MINT (Decimal Value)	MINT (Hexadecimal Value)	N	Reference Frequency (MHz) ^b	PLL Frequency (MHz)
10	48	0x30	0x0	10	480
12	40	0x28	0x0	12	480
16	30	0x1E	0x0	16	480
18	80	0x50	0x2	6	480
20	24	0x18	0x0	20	480
24	20	0x14	0x0	24	480
25	96	0x60	0x4	5	480

a. For all examples listed, Q=0

b. For a given crystal frequency, N should be chosen such that the reference frequency is within 4 to 30 MHz.

30.9.2 PIOSC Specifications

Table 30-19. PIOSC Clock Characteristics

Parameter	Parameter Name	Min	Nom	Max	Unit
F _{PIOSC}	Factory calibration, 0 to +105°C: Internal 16-MHz precision oscillator frequency variance across voltage and temperature range when factory calibration is used	-	-	±4.5%	-
	Factory calibration, -40°C to <0°C	-	-	±10%	-
	Recalibration: Internal 16-MHz precision oscillator frequency variance when recalibration is used at a specific temperature	-	-	±1%	-
T _{START}	PIOSC startup time ^a	-	-	1	μs

a. PIOSC startup time is part of reset and is included in the internal reset timeout value (T_{IRTOU}) given in Table 30-14 on page 1955. Note that the T_{START} value is based on simulation.

30.9.3 Low-Frequency Internal Oscillator Specifications

Table 30-20. Low-Frequency Oscillator Characteristics

Parameter	Parameter Name	Min	Nom	Max	Unit
F _{LFIOSC}	Internal low-frequency oscillator frequency	10	33	75	KHz

30.9.4 Hibernation Clock Source Specifications

Table 30-21. Hibernation Internal Low Frequency Oscillator Clock Characteristics

Parameter	Parameter Name	Min	Nom	Max	Unit
F _{HIBLFIOSC}	Internal Low Frequency Hibernation oscillator frequency	10	33	90	KHz

Table 30-22. Hibernation External Oscillator (XOSC) Input Characteristics

Parameter	Parameter Name	Min	Nom	Max	Unit
F _{HIBXOSC} ^a	Parallel resonance frequency	-	32.768	-	KHz
C ₁ , C ₂	External load capacitance on XOSC0, XOSC1 pins ^b	12	-	24	pF
C _{PKG}	Device package stray shunt capacitance ^b	-	0.5	-	pF

Table 30-22. Hibernation External Oscillator (XOSC) Input Characteristics (continued)

Parameter	Parameter Name	Min	Nom	Max	Unit
C _{PCB}	PCB stray shunt capacitance ^b	-	0.5	-	pF
C _{SHUNT}	Total shunt capacitance ^b	-	-	4	pF
ESR	Crystal effective series resistance, OSCDRV = 0 ^c	-	-	50	kΩ
	Crystal effective series resistance, OSCDRV = 1 ^c	-	-	75	kΩ
DL	Oscillator output drive level	-	-	0.25	μW
T _{START}	Oscillator startup time, when using a crystal ^d	-	600	1500 ^e	ms
V _{IH} ^f	CMOS input high level, when using an external oscillator with Supply > 3.3 V	2.64	-	-	V
	CMOS input high level, when using an external oscillator with 1.8 V ≤ Supply ≤ 3.3 V	0.8 * Supply	-	-	V
V _{IL} ^f	CMOS input low level, when using an external oscillator with 1.8 V ≤ Supply ≤ 3.63 V	-	-	0.2 * Supply	V
V _{HYS} ^f	CMOS input buffer hysteresis, when using an external oscillator with 1.8 V ≤ Supply ≤ 3.63 V	360	960	1390	mV
DC _{HIBOSC_EXT}	External single-Ended (Bypass) reference duty cycle	30	-	70	%

a. The HIB XOSC pins are non-failsafe and must follow the limits detailed in “Non-Power I/O Pins” on page 1975.

b. See information below table.

c. Crystal ESR specified by crystal manufacturer.

d. Oscillator startup time is specified from the time the oscillator is enabled to when it reaches a stable point of oscillation such that the internal clock is valid.

e. Only valid for recommended supply conditions. Measured with OSCDRV bit set (high drive strength enabled, 24 pF).

f. Specification is relative to the larger of V_{DD} or V_{BAT}.

The load capacitors added on the board, C₁ and C₂, should be chosen such that the following equation is satisfied (see Table 30-22 on page 1961 for typical values).

- C_L = load capacitance specified by crystal manufacturer
- $C_L = (C_1 * C_2) / (C_1 + C_2) + C_{PKG} + C_{PCB}$
- C_{SHUNT} = C_{PKG} + C_{PCB} + C₀ (total shunt capacitance seen across XOSC0, XOSC1)
- C_{PKG}, C_{PCB} as measured across the XOSC0, XOSC1 pins excluding the crystal
- Clear the OSCDRV bit in the **Hibernation Control (HIBCTL)** register for C_{1,2} ≤ 18 pF; set the OSCDRV bit for C_{1,2} > 18 pF.
- C₀ = Shunt capacitance of crystal specified by the crystal manufacturer

30.9.5 Main Oscillator Specifications

Table 30-23. Main Oscillator Input Characteristics^a

Parameter	Parameter Name	Min	Nom	Max	Unit
F _{MOSC}	Parallel resonance frequency	4 ^b	-	25	MHz
F _{REF_XTAL_BYPASS}	External clock reference (PLL in BYPASS mode)	0	-	120	MHz
C ₁ , C ₂	External load capacitance on osc0, osc1 pins ^c	12	-	24	pF
C _{PKG}	Device package stray shunt capacitance ^c	-	0.5	-	pF

Table 30-23. Main Oscillator Input Characteristics (continued)

Parameter	Parameter Name	Min	Nom	Max	Unit
C _{PCB}	PCB stray shunt capacitance ^c	-	0.5	-	pF
C _{SHUNT}	Total shunt capacitance ^c	-	-	4	pF
ESR	Crystal effective series resistance, 4 MHz ^{de}	-	-	300	Ω
	Crystal effective series resistance, 6 MHz ^{de}	-	-	200	Ω
	Crystal effective series resistance, 8 MHz ^{de}	-	-	130	Ω
	Crystal effective series resistance, 12 MHz ^{de}	-	-	120	Ω
	Crystal effective series resistance, 16 MHz ^{de}	-	-	100	Ω
	Crystal effective series resistance, 25 MHz ^{de}	-	-	50	Ω
DL	Oscillator output drive level ^f	-	OSC _{PWR}	-	mW
T _{START}	Oscillator startup time, when using a crystal ^g	-	-	18	ms
V _{IH}	CMOS input high level, when using an external oscillator	0.65 * V _{DD}	-	V _{DD}	V
V _{IL}	CMOS input low level, when using an external oscillator	GND	-	0.35 * V _{DD}	V
V _{HYS}	CMOS input buffer hysteresis, when using an external oscillator	150	-	-	mV
DC _{OSC_EXT}	External clock reference duty cycle	45	-	55	%

a. Refer to Table 30-50 on page 1995 and Table 30-51 on page 1995 for additional Ethernet crystal requirements.

b. 5 MHz is the minimum when using the PLL.

c. See information below table.

d. Crystal ESR specified by crystal manufacturer.

e. Crystal vendors can be contacted to confirm these specifications are met for a specific crystal part number if the vendors generic crystal datasheet show limits outside of these specifications.

f. $OSC_{PWR} = (2 * \pi * F_p * C_L * 2.5)^2 * ESR / 2$. An estimation of the typical power delivered to the crystal is based on the C_L, F_p and ESR parameters of the crystal in the circuit as calculated by the OSC_{PWR} equation. Ensure that the value calculated for OSC_{PWR} does not exceed the crystal's drive-level maximum.

g. Oscillator startup time is specified from the time the oscillator is enabled to when it reaches a stable point of oscillation such that the internal clock is valid.

The load capacitors added on the board, C₁ and C₂, should be chosen such that the following equation is satisfied (see Table 30-23 on page 1962 for typical values and Table 30-24 on page 1964 for detailed crystal parameter information).

- C_L = load capacitance specified by crystal manufacturer
- $C_L = (C_1 * C_2) / (C_1 + C_2) + C_{SHUNT}$
- C_{SHUNT} = C₀ + C_{PKG} + C_{PCB} (total shunt capacitance seen across OSC0, OSC1 crystal inputs)
- C_{PKG}, C_{PCB} = the mutual caps as measured across the OSC0, OSC1 pins excluding the crystal.
- C₀ = Shunt capacitance of crystal specified by the crystal manufacturer

Table 30-24 on page 1964 lists part numbers of crystals that have been simulated and confirmed to operate within the specifications in Table 30-23 on page 1962. Other crystals that have nearly identical crystal parameters can be expected to work as well.

In the table below, the crystal parameters labeled C0, C1 and L1 are values that are obtained from the crystal manufacturer. These numbers are usually a result of testing a relevant batch of crystals

on a network analyzer. The parameters labeled ESR, DL and C_L are maximum numbers usually available in the data sheet for a crystal.

The table also includes three columns of Recommended Component Values. These values apply to system board components. C_1 and C_2 are the values in pico Farads of the load capacitors that should be put on each leg of the crystal pins to ensure oscillation at the correct frequency. R_s is the value in $k\Omega$ of a resistor that is placed in series with the crystal between the OSC1 pin and the crystal pin. R_s dissipates some of the power so the Max DI crystal parameter is not exceeded. Only use the recommended C_1 , C_2 , and R_s values with the associated crystal part. The values in the table were used in the simulation to ensure crystal startup and to determine the worst case drive level (WC DI). The value in the WC DI column should not be greater than the Max DI Crystal parameter. The WC DI value can be used to determine if a crystal with similar parameter values but a lower Max DI value is acceptable.

Table 30-24. Crystal Parameters

MFG	MFG Part#	Holder	PKG Size (mm x mm)	Freq (MHz)	Crystal Spec (Tolerance / Stability)	Crystal Parameters						Recommended Component Values			WC DI (μ W)
						Typical Values			Max Values			C_1 (pF)	C_2 (pF)	R_s (k Ω)	
						C_0 (pF)	C_1 (fF)	L1 (mH)	ESR (Ω)	Max DI (μ W)	C_L (pf)				
NDK	NX8045GB- 4.000M-STD- CJL-5	NX8045GB	8 x 4.5	4	30/50 ppm	1.00	2.70	598.10	300	500	8	12	12	0	132
FOX	FQ1045A-4	2-SMD	10 x 4.5	4	30/30 ppm	1.18	4.05	396.00	150	500	10	14	14	0	103
NDK	NX8045GB- 5.000M-STD- CSF-4	NX8045GB	8 x 4.5	5	30/50 ppm	1.00	2.80	356.50	250	500	8	12	12	0	164
NDK	NX8045GB- 6.000M-STD- CSF-4	NX8045GB	8 x 4.5	6	30/50 ppm	1.30	4.10	173.20	250	500	8	12	12	0	214
FOX	FQ1045A-6	2-SMD	10 x 4.5	6	30/30 ppm	1.37	6.26	112.30	150	500	10	14	14	0	209
NDK	NX8045GB- 8.000M-STD- CSF-6	NX8045GB	8 x 4.5	8	30/50 ppm	1.00	2.80	139.30	200	500	8	12	12	0	277
FOX	FQ7050B-8	4-SMD	7 x 5	8	30/30 ppm	1.95	6.69	59.10	80	500	10	14	14	0	217
ECS	ECS-80-16- 28A-TR	HC49/US	12.5 x 4.85	8	50/30 ppm	1.82	4.90	85.70	80	500	16	24	24	0	298
Abracon	AABMM- 12.0000MHZ- 10-D-1-X-T	ABMM	7.2 x 5.2	12	10/20 ppm	2.37	8.85	20.5	50	500	10	12	12	2.0 ^a	124
NDK	NX3225GA- 12.000MHZ- STD-CRG-2	NX3225GA	3.2 x 2.5	12	20/30 ppm	0.70	2.20	81.00	100	200	8	12	12	2.5	147
NDK	NX5032GA- 12.000MHZ- LN-CD-1	NX5032GA	5 x 3.2	12	30/50 ppm	0.93	3.12	56.40	120	500	8	12	12	0	362

Table 30-24. Crystal Parameters (continued)

MFG	MFG Part#	Holder	PKG Size (mm x mm)	Freq (MHz)	Crystal Spec (Tolerance / Stability)	Crystal Parameters						Recommended Component Values			WC DI (μ W)
						Typical Values			Max Values			C ₁ (pF)	C ₂ (pF)	R _s (k Ω)	
						C0 (pF)	C1 (fF)	L1 (mH)	ESR (Ω)	Max DI (μ W)	C _L (pF)				
FOX	FQ5032B-12	4-SMD	5 x 3.2	12	30/30 ppm	1.16	4.16	42.30	80	500	10	14	14	0	370
Abracon	AABMM- 16.0000MHz- 10-D-1-X-T	ABMM	7.2 x 5.2	16	10/20 ppm	3.00	11.00	9.30	50	500	10	12	12	2.0 ^a	143
Ecliptek	ECX-6595- 16.000M	HC-49/UP	13.3 x 4.85	16	15/30 ppm	3.00	12.7	8.1	50	1000	10	12	12	2.0 ^a	139
NDK	NX3225GA- 16.000MHZ- STD-CRG-2	NX3225GA	3.2 x 2.5	16	20/30 ppm	1.00	2.90	33.90	80	200	8	12	12	2	188
NDK	NX5032GA- 16.000MHZ- LN-CD-1	NX5032GA	5 x 3.2	16	30/50ppm	1.02	3.82	25.90	120 ^b	500	8	10	10	0	437
ECS	ECS-160-9-42- CKM-TR	ECX-42	4 x 2.5	16	10/10 ppm	1.47	3.90	25.84	60	300	9	12	12	0.5	289
Abracon	AABMM- 25.0000MHz- 10-D-1-X-T	ABMM	7.2 x 5.2	25	10/20 ppm	3.00	11.00	3.70	50	500	10	12	12	2.0 ^a	158
Ecliptek	ECX-6593- 25.000M	HC-49/UP	13.3 x 4.85	25	15/30 ppm	3.00	12.8	3.2	40	1000	10	12	12	1.5 ^a	159
NDK	NX3225GA- 25.000MHZ- STD-CRG-2	NX3225GA	3.2 x 2.5	25	20/30 ppm	1.10	4.70	8.70	50	200	8	12	12	2	181
NDK	NX5032GA- 25.000MHZ- LD-CD-1	NX5032GA	5 x 3.2	25	30/50 ppm	1.3	5.1	7.1	70	500	8	10	10	1.0 ^a	216
												12	12	0.75 ^c	269
AURIS	Q-25.000M- HC3225/4- F-30-30-E-12-TR	HC3225/4	3.2 x 2.5	25	30/30 ppm	1.58	5.01	8.34	50	500	12	16	16	1	331
FOX	FQ5032B-25	4-SMD	5 x 3.2	25	30/30 ppm	1.69	7.92	5.13	50	500	10	14	14	0.5	433
TXC	7A2570018	NX5032GA	5 x 3.2	25	20/25 ppm	2.0	6.7	6.1	30	350	10	12	12	2.0 ^c	124

a. R_S values as low as 0 Ohms can be used. Using a lower R_S value will result in the WC DL to increase towards the Max DL of the crystal.

b. Although this ESR value is outside of the recommended crystal ESR maximum for this frequency, this crystal has been simulated to confirm proper operation and is valid for use with this device.

c. R_S values as low as 500 Ohms can be used. Using a lower R_S value will result in the WC DL to increase towards the Max DL of the crystal.

30.9.6 System Clock Specification with ADC Operation

Table 30-25. System Clock Characteristics with ADC Operation

Parameter	Parameter Name	Min	Nom	Max	Unit
F_{sysadc}	System clock frequency when the ADC module is operating (when PLL is bypassed).	-	16	-	MHz

30.9.7 System Clock Specification with USB Operation

Table 30-26. System Clock Characteristics with USB Operation

Parameter	Parameter Name	Min	Nom	Max	Unit
F_{sysusb}	System clock frequency when the USB module is operating (note that MOSC must be the clock source, either with or without using the PLL)	30	-	-	MHz

30.10 Sleep Modes

The following tables can be used to calculate the maximum wake time from Sleep or Deep Sleep depending on the specific application. Depending on the application configuration, each of the parameters, except for T_{FLASH} , add sequential latency to the wake time. Flash restoration happens in parallel to the other wake processes and its wake time is normally absorbed by the other latencies. As an example, the wake time for a device in Deep Sleep, with the PIOSC and PLL turned off and the Flash and SRAM in low power mode is calculated as follows:

$$\text{Wake Time} = T_{PIOSCDS} + T_{PLLDS} + T_{SRAML PDS}$$

T_{FLASH} does not contribute to this equation since all other parameters are greater in value.

Note that in Sleep mode the wake time due to a clock source is zero because the device uses the same clock configuration in Run mode; thus, there is no latency involved with respect to the clocks.

Table 30-27. Wake from Sleep Characteristics

Parameter No	Parameter	Parameter Name	Min	Nom	Max	Unit
D1	T_{PIOSC}	Time to restore PIOSC as System Clock in Sleep mode	-	-	N/A ^a	μs
D2	T_{MOSC}	Time to restore MOSC as System Clock in Sleep mode	-	-	N/A ^b	μs
D3	T_{PLL}	Time to restore PLL as System Clock in Sleep mode	-	-	N/A ^c	μs
D4	T_{LDO}	Time to restore LDO to 1.2 V in Sleep mode	-	-	39	μs
D5	T_{FLASH}	Time to restore Flash to active state from low power state in Sleep mode	-	-	5	μs
D6	$T_{SRAML P}$	Time to restore SRAM to active state from low power state in Sleep mode	-	-	15	μs
D7	$T_{SRAMSTBY}$	Time to restore SRAM to active state from standby state in Sleep mode	-	-	15	μs

a. Because the PIOSC is enabled in both Run and Sleep Mode for this configuration, no restoration time is required.

b. Because the MOSC is enabled in both Run and Sleep Mode for this configuration, no restoration time is required.

c. Because the PLL is enabled in both Run and Sleep Mode for this configuration, no restoration time is required.

Table 30-28. Wake from Deep Sleep Characteristics

Parameter No	Parameter	Parameter Name	Min	Nom	Max	Unit
D8	$T_{PIOSCDS}$	Time to restore PIOSC as System Clock in Deep Sleep Mode	-	-	14	Deep Sleep Clock Cycles ^a
D9	T_{MOSCDS}	Time to restore MOSC as System Clock in Deep Sleep Mode	-	-	18	ms
D10	T_{PLLDS}	Time to restore PLL as System Clock in Deep Sleep Mode	-	-	1 cycle of Deep Sleep Clock + 512 cycles of PLL reference Clock ^a	clocks
D11	T_{LDODS}	Time to restore LDO to 1.2 V in Deep Sleep Mode	-	-	39	μs
D12	$T_{FLASHLPDS}$	Time to restore Flash to active state from low power state	-	-	5	μs
D13	$T_{SRAML PDS}$	Time to restore SRAM to active state from low power state	-	-	15	μs

Table 30-28. Wake from Deep Sleep Characteristics (continued)

Parameter No	Parameter	Parameter Name	Min	Nom	Max	Unit
D14	T _{SRAMSTBYDS}	Time to restore SRAM to active state from standby state	-	-	15	μs

a. Deep Sleep Clock can vary. See page 288 for the Deep Sleep Clock options.

30.11 Hibernation Module

The Hibernation module requires special system implementation considerations because it is intended to power down all other sections of its host device, refer to “Hibernation Module” on page 539.

Table 30-29. Hibernation Module Battery Characteristics

Parameter	Parameter Name	Min	Nominal	Max	Unit
V _{BAT}	Battery supply voltage	1.8	3.0	3.6 ^a	V
V _{BATRMP} ^b	V _{BAT} battery supply voltage ramp time	0	-	0.7	V/μs
V _{LOWBAT}	Low battery detect voltage, VBATSEL=0x0	1.8	1.9	2.0	V
	Low battery detect voltage, VBATSEL=0x1	2.0	2.1	2.2	V
	Low battery detect voltage, VBATSEL=0x2	2.2	2.3	2.4	V
	Low battery detect voltage, VBATSEL=0x3	2.4	2.5	2.6	V

a. To ensure proper functionality, any voltage input higher than V_{BAT} Max, must be connected through a diode.

b. For recommended V_{BAT} RC circuit values, refer to the diagrams located in “Hibernation Clock Source” on page 543.

Table 30-30. Hibernation Module Characteristics

Parameter No	Parameter	Parameter Name	Min	Nom	Max	Unit
H1	T _{WAKE}	\overline{WAKE} assertion time	100	-	-	ns
H2	T _{WAKE_TO_HIB}	\overline{WAKE} assert to \overline{HIB} desassert (wake up time)	-	-	1	Hibernation clock period
H3	T _{VDD_RAMP}	V _{DD} ramp to 3.0 V	-	Depends on characteristics of power supply	-	μs
H4	T _{VDD_CODE}	V _{DD} at 3.0 V to internal POR deassert; first instruction executes	-	-	500	μs
H5	DC _{RTCCLK}	Duty cycle for RTCCLK output signal, when using a 32.768-kHz crystal	40	-	60	%
		Duty cycle for RTCCLK output signal, when using a 32.768-kHz external single-ended (bypass) clock source	30	-	70	%

Table 30-31. Hibernation Module Tamper I/O Characteristics

Parameter	Parameter Name	Min	Nominal	Max	Unit
R _{TPU}	TMPR _n pull-up resistor	3.5 -	4.4	5.2 -	MΩ
T _{SP}	TMPR _n pulse width with short glitch filter	62	-	-	μs
T _{LP}	TMPR _n pulse width with long glitch filter	94	-	-	ms
T _{NMIS}	TMPR _n assertion to NMI (short glitch filter)	-	-	95	μs
T _{NMIL}	TMPR _n assertion to NMI (long glitch filter)	-	-	94	ms
V _{IH}	TMPR _n high-level input voltage when operating from VBAT	V _{BAT} *0.8	-	-	V

Figure 30-15. Hibernation Module Timing

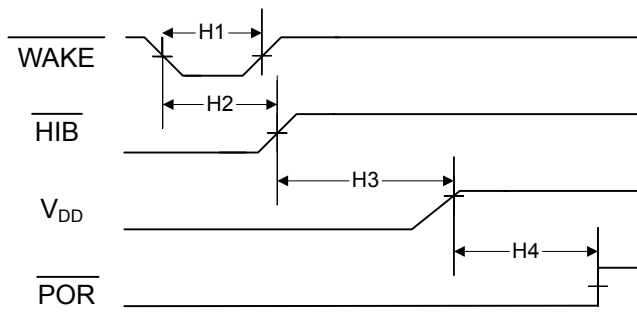

30.12 Flash Memory

Table 30-32. Flash Memory Characteristics

Parameter	Parameter Name	Min	Nom	Max	Unit
PE _{CYC}	Number of program/erase cycles ^a	100,000	-	-	cycles
T _{RET}	Data retention with 100% power-on hours at T _J =85°C	20	-	-	years
T _{RET_EXT}	Data retention with 10% power-on hours at T _J =125°C and 90% power-on hours at T _J =100°C	11	-	-	years
T _{PROG64}	Program time for double-word-aligned (64 bits) data ^b	30	100	300	μs
T _{ERASE}	Page erase time, <1k cycles	-	8	15	ms
	Page erase time, 10k cycles	-	15	40	ms
	Page erase time, 100k cycles	-	75	500	ms
T _{ME}	Mass erase time, <1k cycles	-	10	25	ms
	Mass erase time, 10k cycles	-	20	70	ms
	Mass erase time, 100k cycles	-	300	2500	ms

a. A program/erase cycle is defined as switching the bits from 1-> 0 -> 1.

b. If programming fewer than 64 bits of data, the programming time is the same. For example, if only 32 bits of data need to be programmed, the other 32 bits are masked off.

30.13 EEPROM

Table 30-33. EEPROM Characteristics^a

Parameter	Parameter Name	Min	Nom	Max	Unit
EPE _{CYC} ^b	Number of mass program/erase cycles of a single word ^c	500,000	-	-	cycles
ET _{RET}	Data retention with 100% power-on hours at T _J =85°C	20	-	-	years
ET _{RET_EXTEMP}	Data retention with 10% power-on hours at T _J =125°C and 90% power-on hours at T _J =100°C	11	-	-	years
ET _{PROG}	Program time for 32 bits of data with memory space available	-	110	600	µs
	Program time for 32 bits of data in which a copy to the copy buffer is required, the copy buffer has space and less than 10% of EEPROM endurance used	-	30	-	ms
	Program time for 32 bits of data in which a copy to the copy buffer is required, the copy buffer has space and greater than 90% of EEPROM endurance used	-	-	900	ms
	Program time for 32 bits of data in which a copy of the copy buffer is required, the copy buffer requires an erase and less than 10% of EEPROM endurance used	-	60	-	ms
	Program time for 32 bits of data a copy to the copy buffer is required, the copy buffer requires an erase and greater than 90% of EEPROM endurance used	-	-	1800	ms
ET _{READ}	Read access time ^d	-	7+ 2*(EWS)	9+4*(EWS)	system clocks
ET _{ME}	Mass erase time, <1k cycles	-	8	15	ms
	Mass erase time, 10k cycles	-	15	40	ms
	Mass erase time, 100k cycles	-	75	500	ms

- a. Because the EEPROM operates as a background task and does not prevent the CPU from executing from Flash memory, the operation will complete within the maximum time specified provided the EEPROM operation is not stalled by a Flash memory program or erase operation.
- b. One word can be written more than 500K times, but these writes impact the endurance of the words in the meta-block that the word is within. Different words can be written such that any or all words can be written more than 500K times when write counts per word stay about the same. See the section called "Endurance" on page 628 for more information.
- c. A program/erase cycle is defined as switching the bits from 1-> 0 -> 1.
- d. The EWS field is programmed in the **MEMTIMO** register at Sysctl Offset 0x0C0.

30.14 Input/Output Pin Characteristics

Note: All GPIO signals are 3.3-V tolerant, except for PB1 (USB0VBUS) which is 5-V tolerant. See “Signal Description” on page 751 for more information on GPIO configuration.

Two types of pads are provided on the device:

- Fast GPIO pads: These pads provide variable, programmable drive strength and optimized voltage output levels.
- Slow GPIO pads: These pads provide 2-mA drive strength and are designed to be sensitive to voltage inputs. The following GPIOs port pins are designed with Slow GPIO Pads:
 - PJ1

Note: Port pins $PL6$ and $PL7$ operate as Fast GPIO pads, but have 4-mA drive capability only. GPIO register controls for drive strength, slew rate and open drain have no effect on these pins. The registers which have no effect are as follows: **GPIODR2R**, **GPIODR4R**, **GPIODR8R**, **GPIODR12R**, **GPIOSLR**, and **GPIOODR**.

Note: Port pins $PM[7:4]$ operate as Fast GPIO pads but support only 2-, 4-, 6-, and 8-mA drive capability. 10- and 12-mA drive are not supported. All standard GPIO register controls, except for the **GPIODR12R** register, apply to these port pins.

Table 30-34. Fast GPIO Module Characteristics^{abcd}

Parameter	Parameter Name	Min	Nom	Max	Unit
C_{LGPIO}	Capacitive loading for measurements given in this table ^e	-	-	50	pF
R_{GPIOPU}	Fast GPIO internal pull-up resistor ^f	12.1	16.0	20.2	k Ω
$R_{GPIOPU4MA}$	Fast GPIO $PL6$ and $PL7$ (4-mA only) pull-up resistor	25	-	40	k Ω
R_{GPIOPD}	Fast GPIO internal pull-down resistor ^f	13.0	20.5	35.5	k Ω
$R_{GPIOPD4MA}$	Fast GPIO $PL6$ and $PL7$ (4-mA only) pull-down resistor	10	14.3	17	k Ω
I_{LKG+}	Fast GPIO input leakage current, $0V \leq V_{IN} \leq V_{DD}$ GPIO pins ^g	-	-	400	nA
	Fast GPIO input leakage current, $0V < V_{IN} \leq V_{DD}$, Fast GPIO pins configured as ADC or analog comparator inputs	-	-	400	nA
I_{INJ-}	DC injection current, $V_{IN} \leq 0V$	-	-	60	μ A
$I_{MAXINJ-}$	Max negative injection if not voltage protected ^d	-	-	-0.5	mA
T_{GPIOR}	Fast GPIO rise time, 2-mA drive ^h	-	7.85	11.73	ns
	Fast GPIO rise time, 4-mA drive ^h		4.15	6.35	ns
	Fast GPIO rise time, 8-mA drive ^h		2.33	3.73	ns
	Fast GPIO rise time, 8-mA drive with slew rate control ^h		3.77	5.76	ns
	Fast GPIO rise time, 10-mA drive ^h		1.98	3.22	ns
	Fast GPIO rise time, 12-mA drive ^h		1.75	2.9	ns

Table 30-34. Fast GPIO Module Characteristics (continued)

Parameter	Parameter Name	Min	Nom	Max	Unit
T _{GPIOF}	Fast GPIO fall time, 2-mA drive ⁱ	-	10.3	16.5	ns
	Fast GPIO fall time, 4-mA drive ⁱ		5.15	8.29	ns
	Fast GPIO fall time, 8-mA drive ⁱ		2.58	4.16	ns
	Fast GPIO fall time, 8-mA drive with slew rate control ⁱ		3.54	5.55	ns
	Fast GPIO fall time, 10-mA drive ⁱ		2.07	3.34	ns
	Fast GPIO fall time, 12-mA drive ⁱ		1.73	2.78	ns

- a. V_{DD} must be within the range specified in Table 30-6 on page 1944.
- b. Leakage and Injection current characteristics specified in this table also apply to XOSC0 and XOSC1 inputs.
- c. Note that for the ADC's external reference inputs, care must be taken to avoid a current limiting resistor (refer to I_{VREF} spec in Table 30-44 on page 1985)
- d. I/O pads should be protected if at any point the IO voltage has a possibility of going outside the limits shown in the table. If the part is unpowered, the IO pad Voltage or Current must be limited (as shown in this table) to avoid powering the part through the IO pad, causing potential irreversible damage.
- e. Refer to individual peripheral sections for specific loading information.
- f. This value includes all GPIO except for port pins PL6 and PL7.
- g. The leakage current is measured with V_{IN} applied to the corresponding pin(s). The leakage of digital port pins is measured individually. The port pin is configured as an input and the pull-up/pull-down resistor is disabled.
- h. Time measured from 20% to 80% of V_{DD}.
- i. Time measured from 80% to 20% of V_{DD}.

Table 30-35. Slow GPIO Module Characteristics^{abc}

Parameter	Parameter Name	Min	Nom	Max	Unit
C _{LGPIO}	Capacitive loading for measurements given in this table ^d	-	-	50	pF
R _{GPIOPU}	Slow GPIO internal pull-up resistor	13.8	20.0	31.4	kΩ
R _{GPIOPD}	Slow GPIO internal pull-down resistor	13.0	20.5	35.5	kΩ
I _{LKG+}	Slow GPIO input leakage current, 0 V ≤ V _{IN} ≤ V _{DD} , GPIO pins ^e	-	-	3.25	nA
	Slow GPIO input leakage current, 0 V < V _{IN} ≤ V _{DD} , GPIO pins configured as ADC or analog comparator inputs	-	-	3.25	nA
I _{INJ-}	DC injection current, V _{IN} ≤ 0 V	-	-	3.42	μA
T _{GPIOR}	Slow GPIO rise time, 2-mA drive ^f	-	19.3	29.8	ns
T _{GPIOF}	Slow GPIO fall time, 2-mA drive ^g	-	12.8	21.1	ns

- a. V_{DD} must be within the range specified in Table 30-6 on page 1944.
- b. V_{IN} must be within the range specified in Table 30-1 on page 1942. Leakage current outside of this maximum voltage is not guaranteed and can result in permanent damage of the device.
- c. To avoid potential damage to the part, either the voltage or current on the non-Power, non-WAKE input/outputs should be limited externally as shown in this table.
- d. Refer to individual peripheral sections for specific loading information.
- e. The leakage current is measured with V_{IN} applied to the corresponding pin(s). The leakage of digital port pins is measured individually. The port pin is configured as an input and the pull-up/pull-down resistor is disabled.
- f. Time measured from 20% to 80% of V_{DD}.
- g. Time measured from 80% to 20% of V_{DD}.

30.14.1 Types of I/O Pins and ESD Protection

Caution – All device I/Os pins, except for PB1, are NOT 5V tolerant; voltages in excess of the limits shown in Table 30-6 on page 1944 can permanently damage the device. PB1 is used for the USB's USB0VBUS signal, which requires a 5-V input.

30.14.1.1 Hibernate $\overline{\text{WAKE}}$ pin

The Hibernate $\overline{\text{WAKE}}$ pin uses ESD protection, similar to the one shown in Figure 30-16 on page 1975. This ESD protection prevents a direct path between this pad and any power supply rails in the device. The $\overline{\text{WAKE}}$ pad input voltage should be kept inside the maximum ratings specified in Table 30-1 on page 1942 to ensure current leakage and current injections are within acceptable range. Current leakages and current injection for these pins are specified in Table 30-36 on page 1975.

Figure 30-16. ESD Protection

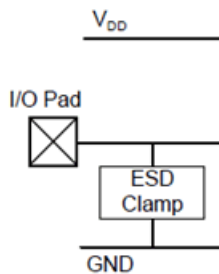

Table 30-36. Pad Voltage/Current Characteristics for Hibernate $\overline{\text{WAKE}}$ Pin^{ab}

Parameter	Parameter Name	Min	Nom	Max	Unit
$I_{\text{LKG}+}$	Positive IO leakage for $V_{\text{DD}} \leq V_{\text{IN}} \leq V_{\text{BAT}} + 0.3\text{V}$	-	-	300	nA
$I_{\text{LKG}-}$	Negative IO leakage for $-0.3\text{V} \leq V_{\text{IN}} \leq 0\text{V}^{\text{c}}$	-	-	43.3	μA
$I_{\text{INJ}+}$	Max positive injection if not voltage protected ^d	-	-	2	mA
$I_{\text{INJ}-}$	Max negative injection if not voltage protected ^d	-	-	-0.5	mA

a. V_{IN} must be within the range specified in Table 30-1 on page 1942. Leakage current outside of this maximum voltage is not guaranteed and can result in permanent damage of the device.

b. V_{DD} must be within the range specified in Table 30-6 on page 1944.

c. Leakage outside the minimum range (-0.3V) is unbounded and must be limited to $I_{\text{INJ}-}$ using an external resistor.

d. If the I/O pad is not voltage limited, it should be current limited (to $I_{\text{INJ}+}$ and $I_{\text{INJ}-}$) if there is any possibility of the pad voltage exceeding the V_{IO} limits (including transient behavior during supply ramp up, or at any time when the part is unpowered).

30.14.1.2 Non-Power I/O Pins

Most non-power I/Os (with the exception of the I/O pad for Hibernate $\overline{\text{WAKE}}$ input) have ESD protection as shown in Figure 30-17 on page 1976.

These I/Os have an ESD clamp to ground and a diode connection to the corresponding power supply rail. The voltage and current of these I/Os should follow the specifications in Table 30-37 on page 1976 to prevent potential damage to the device. In addition, it is recommended that the ADC external reference specifications in Table 30-44 on page 1985 be adhered to prevent any gain error.

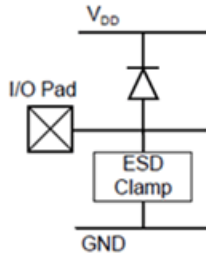
Figure 30-17. ESD Protection for Non-Power Pins (Except $\overline{\text{WAKE}}$ Signal)Table 30-37. Non-Power I/O Pad Voltage/Current Characteristics^{abc}

Parameter	Parameter Name	Min	Nom	Max	Unit
V_{IO}^d	IO pad voltage limits if voltage protected	-0.3	V_{DD}	$V_{DD}+0.3$	V
I_{LKG+}	Positive IO leakage for $V_{DD} \leq V_{IN} \leq V_{IO} \text{ MAX}^e$	-	-	400	nA
I_{LKG-}	Negative IO leakage for $V_{IO} \text{ MIN} \leq V_{IN} \leq 0V^e$	-	-	60	μA
I_{INJ+}	Max positive injection if not voltage protected ^f	-	-	2	mA
I_{INJ-}	Max negative injection if not voltage protected ^f	-	-	-0.5	mA

- To avoid potential damage to the part, either the voltage or current on the non-Power, non- $\overline{\text{WAKE}}$ input/outputs should be limited externally as shown in this table.
- Note that for the ADC's external reference inputs, care must be taken to avoid a current limiting resistor (refer to IVREF spec in Table 30-44 on page 1985)
- I/O pads should be protected if at any point the IO voltage has a possibility of going outside the limits shown in the table. If the part is unpowered, the IO pad Voltage or Current must be limited (as shown in this table) to avoid powering the part through the IO pad, causing potential irreversible damage.
- The Hibernate $\overline{\text{XOSC}}$ pins are non-failsafe and should follow the limits for V_{IO} with respect to both V_{DD} and V_{BAT} . Thus V_{IO} for the HIB $\overline{\text{XOSC}}$ pins should also fall within a MIN of -0.3 and a MAX of $V_{BAT} + 0.3$.
- MIN and MAX leakage current for the case when the I/O is voltage protected to $V_{IO} \text{ Min}$ or $V_{IO} \text{ Max}$.
- If the I/O pad is not voltage limited, it should be current limited (to I_{INJ+} and I_{INJ-}) if there is any possibility of the pad voltage exceeding the V_{IO} limits (including transient behavior during supply ramp up, or at any time when the part is unpowered).

30.15 External Peripheral Interface (EPI)

Table 30-38. EPI Interface Load Conditions

Signals	Load Value (C_L)
EPI0S[35:0] SDRAM interface	30 pF
EPI0S[35:0] General-Purpose interface	
EPI0S[35:0] Host-Bus interface	
EPI0S[35:0] PSRAM interface	40 pF

When the EPI module is in SDRAM mode, EPI CLK must be configured to 12 mA. The EPI data bus can be configured to 8 mA. Table 30-39 on page 1977 shows the rise and fall times in SDRAM mode. When the EPI module is in Host-Bus or General-Purpose mode, the values in “Input/Output Pin Characteristics” on page 1973 should be used.

Table 30-39. EPI SDRAM Characteristics

Parameter	Parameter Name	Condition	Min	Nom	Max	Unit
T_{SDRAMR}	EPI Rise Time (from 20% to 80% of V_{DD})	12-mA drive, $C_L = 30$ pF	-	2	3	ns
T_{SDRAMF}	EPI Fall Time (from 80% to 20% of V_{DD})	12-mA drive, $C_L = 30$ pF	-	2	3	ns

Table 30-40. EPI SDRAM Interface Characteristics^a

Parameter No	Parameter	Parameter Name	Min	Nom	Max	Unit
E1	T_{CK}	SDRAM Clock period	16.67	-	-	ns
E2	T_{CH}	SDRAM Clock high time	8.33	-	-	ns
E3	T_{CL}	SDRAM Clock low time	8.33	-	-	ns
E4	T_{COV}	CLK to output valid	-	-	4	ns
E5	T_{COI}	CLK to output invalid	-	-	4	ns
E6	T_{COT}	CLK to output tristate	-	-	4	ns
E7	T_S	Input set up to CLK	8.5	-	-	ns
E8	T_H	CLK to input hold	0	-	-	ns
E9	T_{PU}	Power-up time	100	-	-	μ s
E10	T_{RP}	Precharge all banks	20	-	-	ns
E11	T_{RFC}	Auto refresh	66	-	-	ns
E12	T_{MRD}	Program mode register	2	-	-	EPI CLK

a. The EPI SDRAM interface must use 12-mA drive.

Figure 30-18. SDRAM Initialization and Load Mode Register Timing

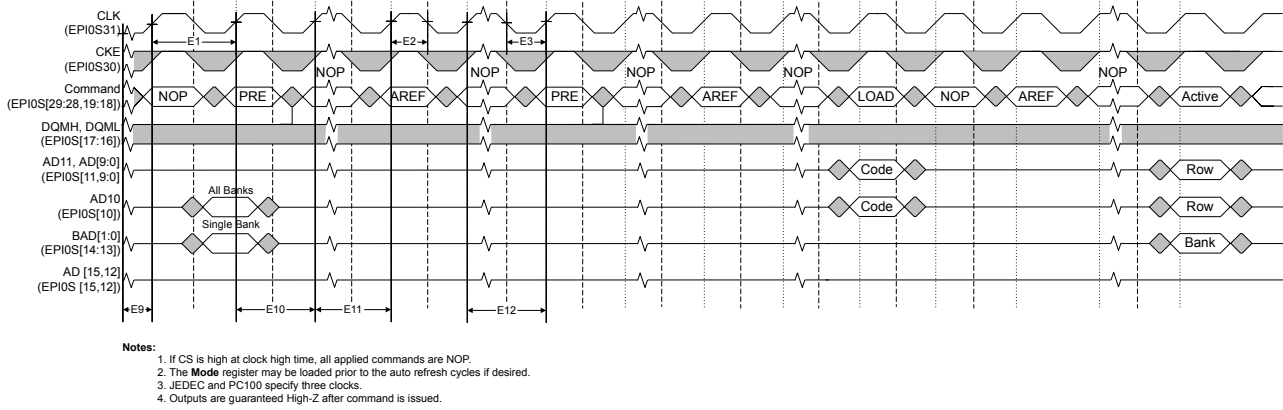

Figure 30-19. SDRAM Read Timing

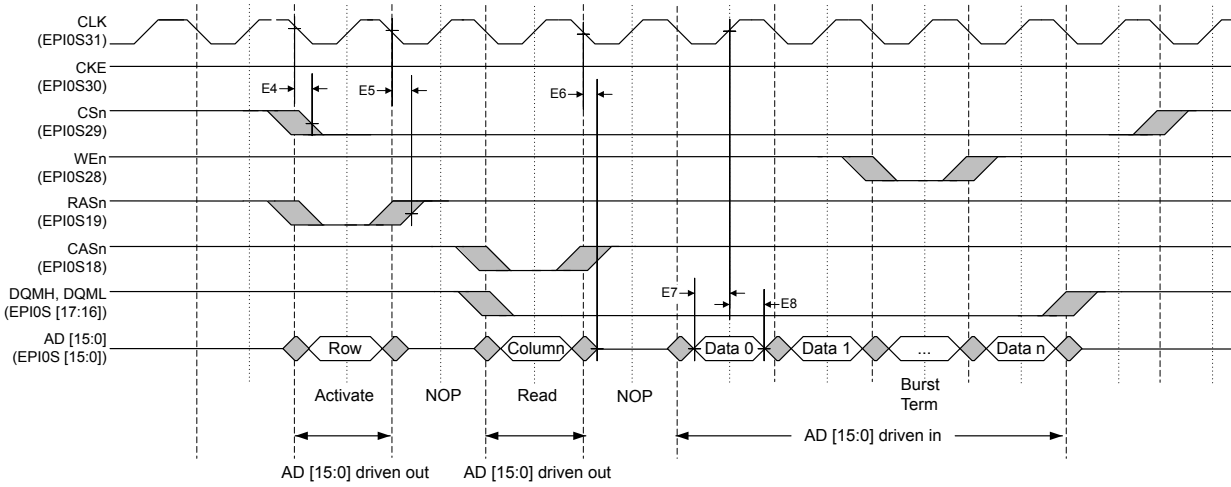

Figure 30-20. SDRAM Write Timing

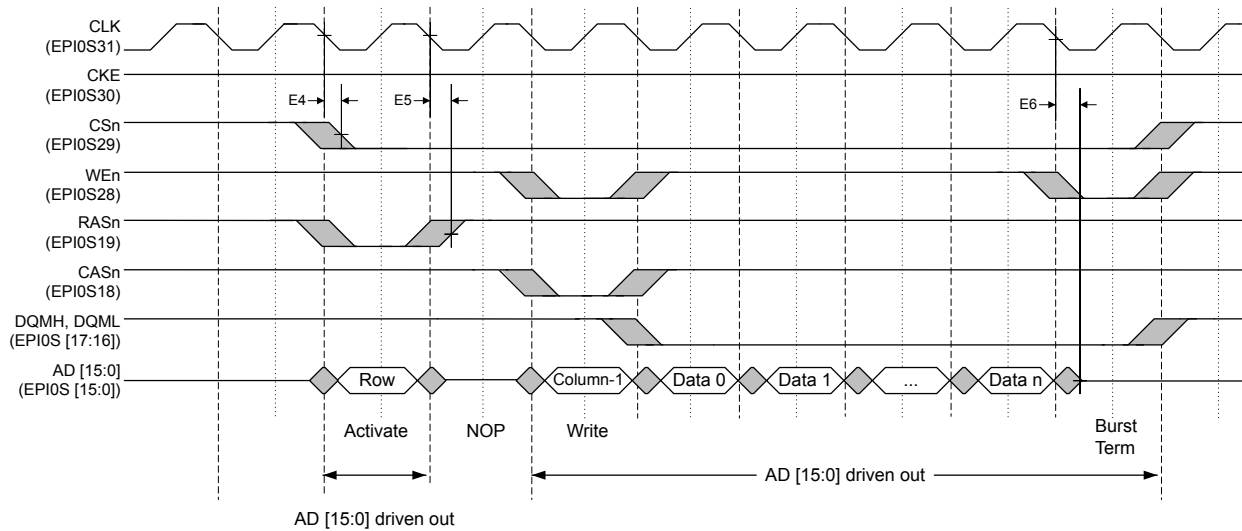
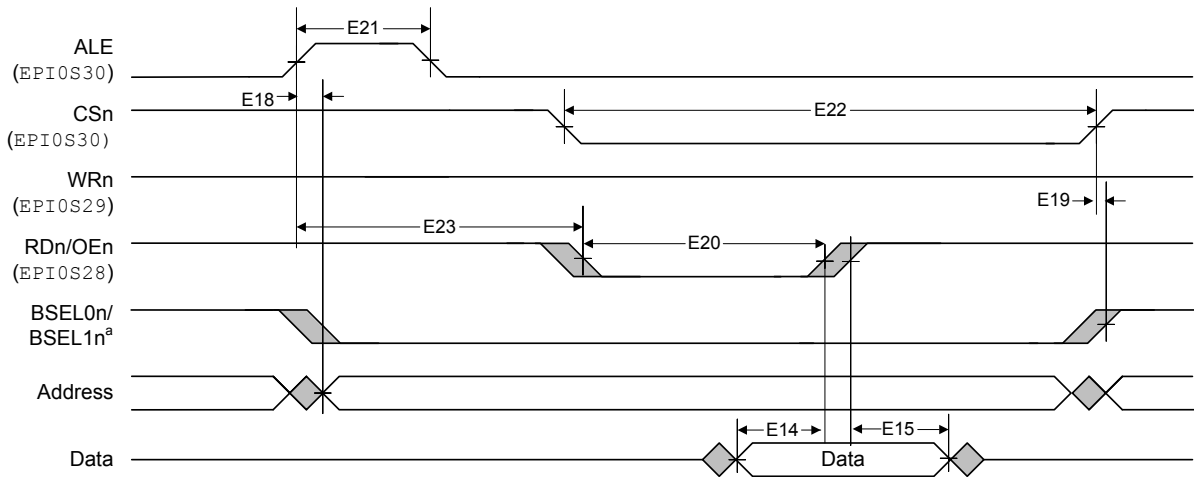

Table 30-41. EPI Host-Bus 8 and Host-Bus 16 Interface Characteristics

Parameter No	Parameter	Parameter Name	Min	Nom	Max	Unit
E14	T_{ISU}	Read data set up time	10	-	-	ns
E15	T_{IH}	Read data hold time	0	-	-	ns
E16	T_{DV}	WRn to write data valid	-	-	3.6	ns
E17	T_{DI}	Data hold from WRn invalid	1	-	-	EPI Clocks
E18	T_{OV}	ALE/CSn to output valid	-	-	4	ns
E19	T_{OINV}	CSn to output invalid	-	-	4	ns
E20	T_{STLOW}	WRn / RDn strobe width low	1	-	-	EPI Clocks
E21	$T_{ALEHIGH}$	ALE width high	-	1	-	EPI Clocks
E22	T_{CSLOW}	CSn width low	2	-	-	EPI Clocks
E23	T_{ALEST}	ALE rising to WRn / RDn strobe falling	2	-	-	EPI Clocks
E24	T_{ALEADD}	ALE falling to Address tristate	1	-	-	EPI Clocks

Figure 30-21. Host-Bus 8/16 Asynchronous Mode Read Timing



^a BSEL0n and BSEL1n are available in Host-Bus 16 mode only.

Figure 30-22. Host-Bus 8/16 Asynchronous Mode Write Timing

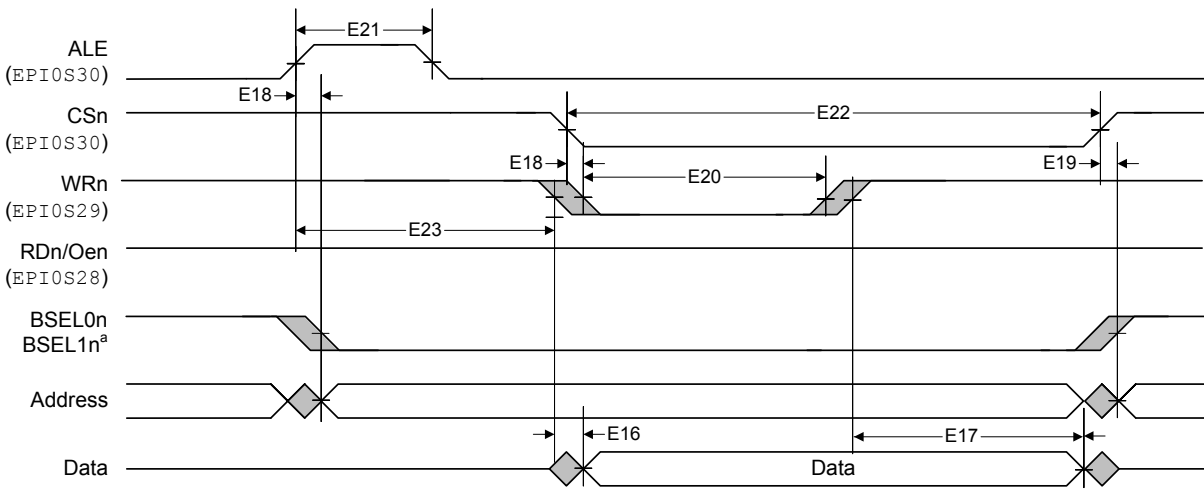

^a BSEL0n and BSEL1n are available in Host-Bus 16 mode only.

Figure 30-23. Host-Bus 8/16 Mode Asynchronous Muxed Read Timing

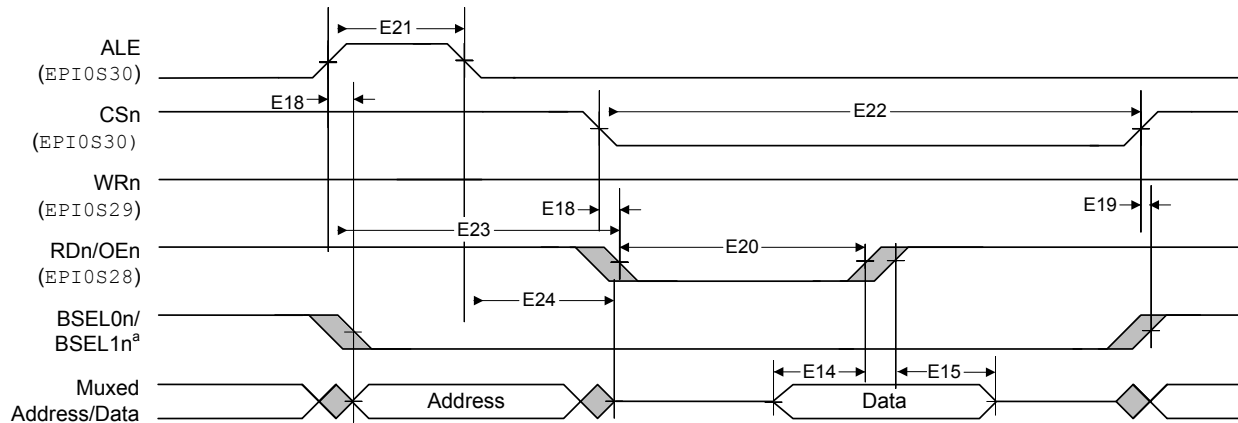

^a BSEL0n and BSEL1n are available in Host-Bus 16 mode only.

Figure 30-24. Host-Bus 8/16 Mode Asynchronous Muxed Write Timing

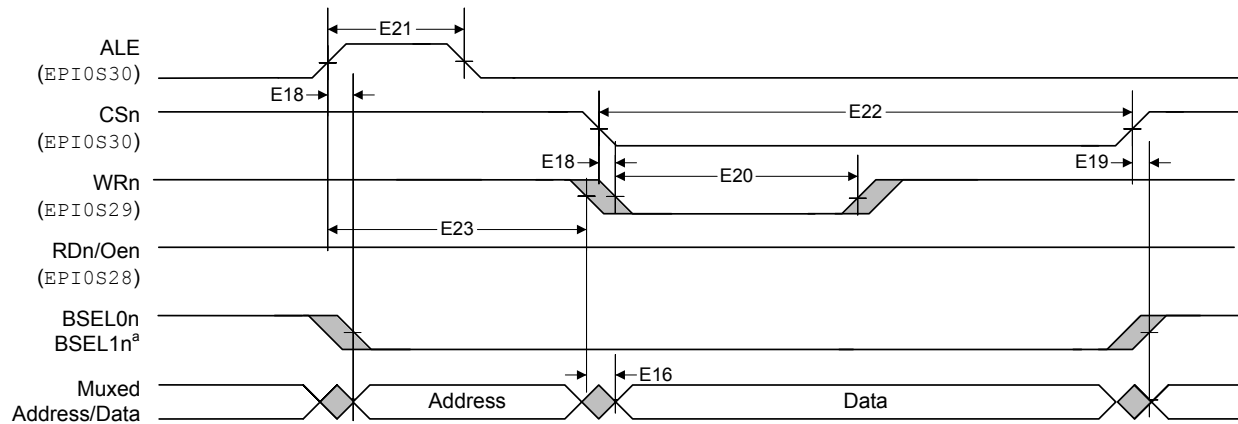

^a BSEL0n and BSEL1n are available in Host-Bus 16 mode only.

Table 30-42. EPI General-Purpose Interface Characteristics

Parameter No	Parameter	Parameter Name	Min	Nom	Max	Unit
E25	T_{CK}	General-Purpose Clock period	16.67	-	-	ns
E26	T_{CH}	General-Purpose Clock high time	8.33	-	-	ns
E27	T_{CL}	General-Purpose Clock low time	8.33	-	-	ns
E28	T_{ISU}	Input signal set up time to rising clock edge	8.50	-	-	ns
E29	T_{IH}	Input signal hold time from rising clock edge	0	-	-	ns
E30	T_{DV}	Falling clock edge to output valid	-	-	4	ns
E31	T_{DI}	Falling clock edge to output invalid	-	-	4	ns
E32	T_{RDYSU}	iRDY assertion or deassertion set up time to falling clock edge	8.5	-	-	ns

Figure 30-25. General-Purpose Mode Read and Write Timing

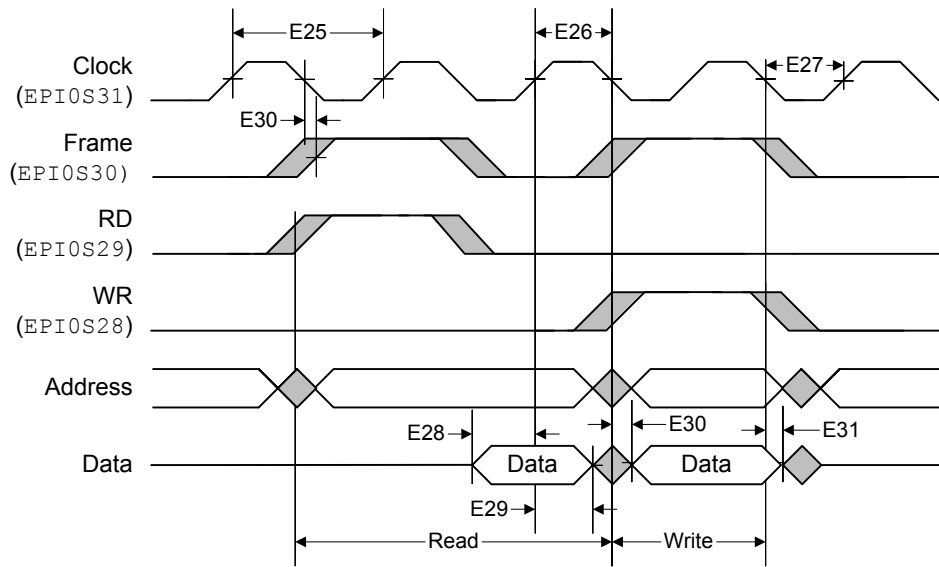

Note: This figure illustrates accesses where the FRM50 bit is clear, the FRMCNT field is 0x0 and the WR2CYC bit is clear.

Table 30-43. EPI PSRAM Interface Characteristics

Parameter No	Parameter	Parameter Name	Min	Nom	Max	Unit
E33	T_{EPICLK}	EPI_CLK period	20	-	-	ns
E34	T_{RTFT}	EPI_CLK rise or fall time	-	-	1.8	ns
E35	T_{OV}	Falling EPI_CLK to Address/Write Data or Control output valid ^a	4.5	-	20	ns
E36	T_{HT}	Falling EPI_CLK to Address/Write Data or Control hold time ^a	2	-	-	ns
E37	T_{SUP}	Read data setup time from EPI_CLK rising	-	-	9	ns
E38	T_{DH}	Read data output hold from EPI_CLK rising	0	-	-	ns
E39	T_{IRV}	iRDY setup time	-	-	9	ns
E40	T_{IRH}	iRDY hold time	-	-	9	ns

a. Control output includes WRn, RDn, OEn, BSELn, ALE, and CSn.

Figure 30-26. PSRAM Single Burst Read

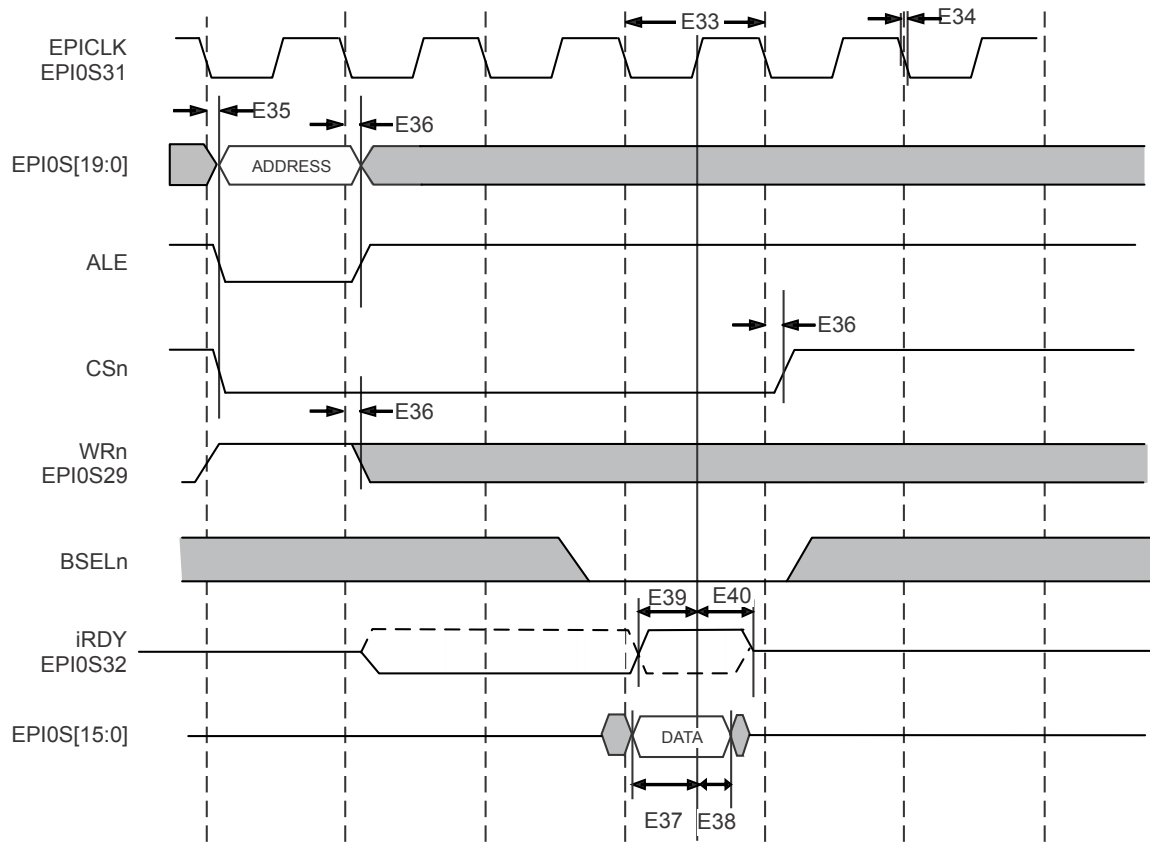
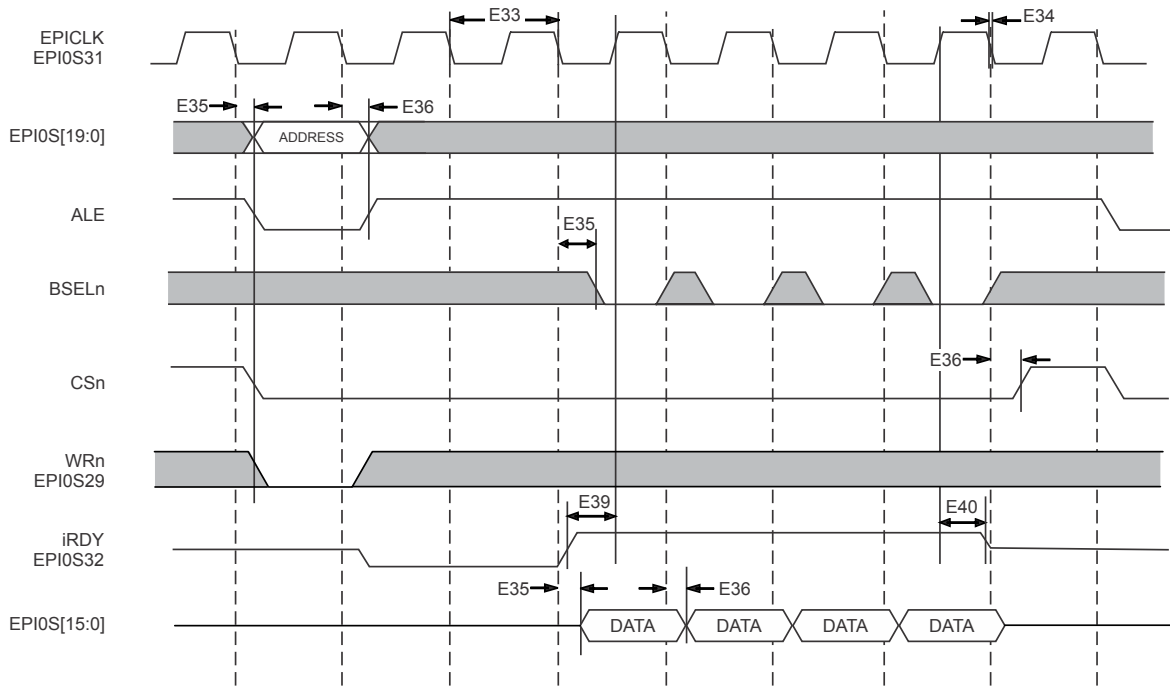

Figure 30-27. PSRAM Single Burst Write



30.16 Analog-to-Digital Converter (ADC)

Table 30-44. ADC Electrical Characteristics for ADC at 1 Msps^{ab}

Parameter	Parameter Name	Min	Nom	Max	Unit
POWER SUPPLY REQUIREMENTS					
V _{DDA}	ADC supply voltage	2.97	3.3	3.63	V
G _{ND} A	ADC ground voltage	-	0	-	V
V _{DDA} / G _{ND} A VOLTAGE REFERENCE					
C _{REF}	Voltage reference decoupling capacitance	-	1.0 // 0.01 ^c	-	μF
EXTERNAL VOLTAGE REFERENCE INPUT					
V _{REF+}	Positive external voltage reference for ADC, when V _{REF} field in the ADCCTL register is 0x1-	2.4	V _{DDA}	V _{DDA}	V
I _{VREF}	Current on V _{REF+} input, using external V _{REF+} = 3.3 V	-	330.5	440	μA
I _{LVREF}	DC leakage current on V _{REF+} input when external VREF disabled	-	-	2.0	μA
C _{REF}	External reference decoupling capacitance	-	1.0 // 0.01 ^c	-	μF
ANALOG INPUT					
V _{ADCIN}	Single-ended, full-scale analog input voltage, internal reference ^{de}	0	-	V _{DDA}	V
	Differential, full-scale analog input voltage, internal reference ^{df}	-V _{DDA}	-	V _{VDDA}	V
	Single-ended, full-scale analog input voltage, external reference ^e	G _{ND} A	-	V _{REF+}	V
	Differential, full-scale analog input voltage, external reference ^g	-(V _{REF+} - G _{ND} A)	-	V _{REF+ - G_{ND}A}	V
V _{INCM}	Input common mode voltage, differential mode ^h	-	-	$[(V_{REF+} + V_{REF-}) / 2] \pm 0.025$	V
I _L	ADC input leakage current ⁱ	-	-	2.0	μA
R _{ADC}	ADC equivalent input resistance ⁱ	-	-	2.5	kΩ
C _{ADC}	ADC equivalent input capacitance ⁱ	-	-	10	pF
R _S	Analog source resistance ⁱ	-	-	500	Ω
SAMPLING DYNAMICS					
F _{ADC}	ADC conversion clock frequency ^j	-	16	-	MHz
F _{CONV}	ADC conversion rate	1			Msps
T _S	ADC sample time	-	250	-	ns
T _C	ADC conversion time ^k	-	1	-	μs
T _{LT}	Latency from trigger to start of conversion	-	2	-	ADC clocks
SYSTEM PERFORMANCE when using external reference ^{lm}					
N	Resolution	12			bits
INL	Integral nonlinearity error, over full input range	-	±1.5	±3.0	LSB
DNL	Differential nonlinearity error, over full input range	-	±0.8	+2.0/-1.0 ⁿ	LSB
E _O	Offset error	-	±1.0	±3.0	LSB
E _G	Gain error ^o	-	±2.0	±3.0	LSB

Table 30-44. ADC Electrical Characteristics for ADC at 1 Msps (continued)

Parameter	Parameter Name	Min	Nom	Max	Unit
E_T	Total unadjusted error, over full input range ^p	-	±2.5	±4.0	LSB
SYSTEM PERFORMANCE when using internal reference					
N	Resolution	12			bits
INL	Integral nonlinearity error, over full input range	-	±1.5	±3.0	LSB
DNL	Differential nonlinearity error, over full input range	-	±0.8	+2.0/-1.0 ⁿ	LSB
E_O	Offset error	-	±5.0	±15.0	LSB
E_G	Gain error ^o	-	±10.0	±30.0	LSB
E_T	Total unadjusted error, over full input range ^p	-	±10.0	±30.0	LSB
DYNAMIC CHARACTERISTICS ^{qf}					
SNR_D	Signal-to-noise-ratio, Differential input, V_{ADCIN} : -20dB FS, 1KHz ^s	70	72	-	dB
SDR_D	Signal-to-distortion ratio, Differential input, V_{ADCIN} : -3dB FS, 1KHz ^{stu}	72	75	-	dB
$SNDR_D$	Signal-to-Noise+Distortion ratio, Differential input, V_{ADCIN} : -3dB FS, 1KHz ^{svw}	68	70	-	dB
SNR_S	Signal-to-noise-ratio, Single-ended input, V_{ADCIN} : -20dB FS, 1KHz ^x	60	65	-	dB
SDR_S	Signal-to-distortion ratio, Single-ended input, V_{ADCIN} : -3dB FS, 1KHz ^{tu}	70	72	-	dB
$SNDR_S$	Signal-to-Noise+Distortion ratio, Single-ended input, V_{ADCIN} : -3dB FS, 1KHz ^{xvw}	60	63	-	dB
TEMPERATURE SENSOR					
V_{TSENS}	Temperature sensor voltage, junction temperature 25 °C	-	1.633	-	V
S_{TSENS}	Temperature sensor slope at: -40°C to 85 °C ambient (industrial temperature part) -40°C to 105 °C ambient (extended temperature part)	-	-13.3	-	mV/°C
E_{TSENS}	Temperature sensor accuracy at: ^y -40°C to 85 °C ambient (industrial temperature part) -40°C to 105 °C ambient (extended temperature part)	-	-	±5	°C

a. Values are at $V_{REF+} = 3.3V$, $F_{ADC} = 16$ MHz unless otherwise noted.

b. Best design practices suggest that static or quiet digital I/O signals be configured adjacent to sensitive analog inputs to reduce capacitive coupling and cross talk. Unexpected results can occur if a switching digital I/O is placed adjacent to an ADC input channel or voltage reference input. In addition, analog signals configured adjacent to ADC input channels or reference inputs must meet the R_{ADC} equivalent input resistance given in this table and must be band-limited to 100 kHz or lower.

c. Two capacitors in parallel. Note that these capacitors should be as close to the die as possible.

d. Internal reference is connected directly between V_{DDA} and $GNDA$ ($V_{REFi} = V_{DDA} - GNDA$). In this mode, E_O , E_G , E_T , and dynamic specifications are adversely affected due to internal voltage drop and noise on V_{DDA} and $GNDA$. Internal reference voltage is selected when V_{REF} field in the **ADCCTL** register is 0x0.

e. $V_{ADCIN} = V_{INP} - V_{INN}$

f. With signal common mode as $V_{DDA}/2$.

- g. With signal common mode as ($V_{REF+} + GND$).
- h. This parameter is defined as the average of the differential inputs.
- i. As shown in Figure 30-29 on page 1990, R_{ADC} is the total equivalent resistance in the input line all the way up to the sampling node at the input of the ADC.
- j. See "System Clock Specification with ADC Operation" on page 1966 for full ADC clock frequency specification.
- k. ADC conversion time (T_c) includes the ADC sample time (T_s).
- l. Low noise environment is assumed in order to obtain values close to spec. Board must have good ground isolation between analog and digital grounds, a clean reference voltage is assumed, and input signal must be bandlimited to Nyquist bandwidth. No anti-aliasing filter is provided internally.
- m. ADC static measurements taken by averaging over several samples. At least 20-sample averaging is assumed to obtain expected typical or maximum spec values.
- n. 12-bit DNL
- o. Gain error is measured at max code after compensating for offset. Gain error is equivalent to "Full Scale Error." It can be given in % of slope error, or in LSB, as done here.
- p. Total Unadjusted Error is the maximum error at any one code versus the ideal ADC curve. It includes all other errors (offset error, gain error and INL) at any given ADC code.
- q. A low noise environment is assumed in order to obtain values close to spec. The board must have good ground isolation between analog and digital grounds and a clean reference voltage. The input signal must be band-limited to Nyquist bandwidth. No anti-aliasing filter is provided internally.
- r. ADC dynamic characteristics are measured using low-noise board design, with low-noise reference voltage (< -74 dB noise level in signal BW) and low-noise analog supply voltage. Board noise and ground bouncing couple into the ADC and affect dynamic characteristics. Clean external reference must be used to achieve shown specs.
- s. Differential signal with correct common mode, applied between two ADC inputs.
- t. SDR = -THD in dB.
- u. For higher frequency inputs, degradation in SDR should be expected.
- v. SNDR = $S/(N+D)$ = SINAD (in dB)
- w. Effective number of bits (ENOB) can be calculated from SNDR: $ENOB = (SNDR - 1.76) / 6.02$.
- x. Single ended inputs are more sensitive to board and trace noise than differential inputs; SNR and SNDR measurements on single-ended inputs are highly dependent on how clean the test set-up is. If the input signal is not well-isolated on the board, higher noise than specified could potentially be seen at the ADC output.
- y. Note that this parameter does not include ADC error.

Table 30-45. ADC Electrical Characteristics for ADC at 2 Msps^{ab}

Parameter	Parameter Name	Min	Nom	Max	Unit
POWER SUPPLY REQUIREMENTS					
V_{DDA}	ADC supply voltage	2.97	3.3	3.63	V
GND	ADC ground voltage	-	0	-	V
VDDA / GND VOLTAGE REFERENCE					
C_{REF}	Voltage reference decoupling capacitance	-	1.0 // 0.01 ^c	-	μ F
EXTERNAL VOLTAGE REFERENCE INPUT					
V_{REF+}	Positive external voltage reference for ADC, when V_{REF} field in the ADCCTL register is $0x1^d$.	2.4	V_{DDA}	V_{DDA}	V
I_{VREF}	Current on V_{REF+} input, using external V_{REF+} = 3.3 V	-	330.5	440	μ A
I_{LVREF}	DC leakage current on V_{REF+} input when external V_{REF} disabled	-	-	2.0	μ A
C_{REF}	External reference decoupling capacitance ^d	-	1.0 // 0.01 ^c	-	μ F
ANALOG INPUT					

Table 30-45. ADC Electrical Characteristics for ADC at 2 Msps (continued)

Parameter	Parameter Name	Min	Nom	Max	Unit
V _{ADCIN}	Single-ended, full-scale analog input voltage, internal reference ^{ef}	0	-	V _{DDA}	V
	Differential, full-scale analog input voltage, internal reference ^{eg}	-V _{DDA}	-	V _{DDA}	V
	Single-ended, full-scale analog input voltage, external reference ^{df}	V _{REFA-}	-	V _{REFA+}	V
	Differential, full-scale analog input voltage, external reference ^{dh}	-(V _{REFA+} - V _{REFA-})	-	V _{REFA+} - V _{REFA-}	V
V _{INCM}	Input common mode voltage, differential mode ⁱ	-	-	[(V _{REFA+} + V _{REFA-}) / 2] ± 0.025	V
I _L	ADC input leakage current ^j	-	-	2.0	µA
R _{ADC}	ADC equivalent input resistance ^j	-	-	2.5	kΩ
C _{ADC}	ADC equivalent input capacitance ^j	-	-	10	pF
R _S	Analog source resistance ^j	-	-	250	Ω
SAMPLING DYNAMICS					
F _{ADC}	ADC conversion clock frequency ^k	-	32	-	MHz
F _{CONV}	ADC conversion rate	2			MSPS
T _S	ADC sample time	-	125	-	ns
T _C	ADC conversion time ^l	-	0.5	-	µs
T _{LT}	Latency from trigger to start of conversion	-	2	-	ADC clocks
SYSTEM PERFORMANCE when using external reference ^{mn}					
N	Resolution	12			bits
INL	Integral nonlinearity error, over full input range	-	±1.5	±3.0	LSB
DNL	Differential nonlinearity error, over full input range	-	±0.8	+2.0/-1.0 ^o	LSB
E _O	Offset error	-	±1.0	±3.0	LSB
E _G	Gain error ^p	-	±2.0	±3.0	LSB
E _T	Total unadjusted error, over full input range ^q	-	±2.5	±4.0	LSB
SYSTEM PERFORMANCE when using internal reference					
N	Resolution	12			bits
INL	Integral nonlinearity error, over full input range	-	±1.5	±3.0	LSB
DNL	Differential nonlinearity error, over full input range	-	±0.8	+2.0/-1.0 ^o	LSB
E _O	Offset error	-	±5.0	±15.0	LSB
E _G	Gain error ^p	-	±10.0	±30.0	LSB
E _T	Total unadjusted error, over full input range ^q	-	±10.0	±30.0	LSB
DYNAMIC CHARACTERISTICS ^{rs}					
SNR _D	Signal-to-noise-ratio, Differential input, V _{ADCIN} : -20dB FS, 1KHz ^t	68	72	-	dB
SDR _D	Signal-to-distortion ratio, Differential input, V _{ADCIN} : -3dB FS, 1KHz ^{tu}	70	75	-	dB
SNDR _D	Signal-to-Noise+Distortion ratio, Differential input, V _{ADCIN} : -3dB FS, 1KHz ^{twx}	65	70	-	dB

Table 30-45. ADC Electrical Characteristics for ADC at 2 Msps (continued)

Parameter	Parameter Name	Min	Nom	Max	Unit
SNR _S	Signal-to-noise-ratio, Single-ended input, V _{ADCIN} : -20dB FS, 1KHz ^y	58	65	-	dB
SDR _S	Signal-to-distortion ratio, Single-ended input, V _{ADCIN} : -3dB FS, 1KHz ^{uv}	68	72	-	dB
SNDR _S	Signal-to-Noise+Distortion ratio, Single-ended input, V _{ADCIN} : -3dB FS, 1KHz ^{ywx}	58	63	-	dB

- a. Values are at V_{REF+} = 3.3V, F_{ADC} = 32 MHz unless otherwise noted.
- b. Best design practices suggest that static or quiet digital I/O signals be configured adjacent to sensitive analog inputs to reduce capacitive coupling and cross talk. Unexpected results can occur if a switching digital I/O is placed adjacent to an ADC input channel or voltage reference input. In addition, analog signals configured adjacent to ADC input channels or reference inputs must meet the R_{ADC} equivalent input resistance given in this table and must be band-limited to 100 kHz or lower.
- c. Two capacitors in parallel. Note that these capacitors should be as close to the die as possible.
- d. Assumes external filtering network between VREFA+ and VREFA- as shown in Figure 30-28 on page 1990. External reference noise level must be under 12bit (-74 dB) of Full Scale input, over input bandwidth, measured at VREFA+ - VREFA-.
- e. Internal reference is connected directly between V_{DDA} and GNDA (VREFI = V_{DDA} - GNDA). In this mode, E_O, E_G, E_T, and dynamic specifications are adversely affected due to internal voltage drop and noise on V_{DDA} and GNDA. Internal reference voltage is selected when VREF field in the **ADCCTL** register is 0x0.
- f. V_{ADCIN} = V_{INP} - V_{INN}
- g. With signal common mode as V_{DDA}/2.
- h. With signal common mode as (V_{REF+} + V_{REF-})/2.
- i. This parameter is defined as the average of the differential inputs.
- j. As shown in Figure 30-29 on page 1990, R_{ADC} is the total equivalent resistance in the input line all the way up to the sampling node at the input of the ADC.
- k. See "System Clock Specification with ADC Operation" on page 1966 for full ADC clock frequency specification.
- l. ADC conversion time (T_c) includes the ADC sample time (T_s).
- m. Low noise environment is assumed in order to obtain values close to spec. Board must have good ground isolation between analog and digital grounds, a clean reference voltage is assumed, and input signal must be bandlimited to Nyquist bandwidth. No anti-aliasing filter is provided internally.
- n. ADC static measurements taken by averaging over several samples. At least 20-sample averaging is assumed to obtain expected typical or maximum spec values.
- o. 12-bit DNL
- p. Gain error is measured at max code after compensating for offset. Gain error is equivalent to "Full Scale Error." It can be given in % of slope error, or in LSB, as done here.
- q. Total Unadjusted Error is the maximum error at any one code versus the ideal ADC curve. It includes all other errors (offset error, gain error and INL) at any given ADC code.
- r. A low noise environment is assumed in order to obtain values close to spec. The board must have good ground isolation between analog and digital grounds and a clean reference voltage. The input signal must be band-limited to Nyquist bandwidth. No anti-aliasing filter is provided internally.
- s. ADC dynamic characteristics are measured using low-noise board design, with low-noise reference voltage (< -74dB noise level in signal BW) and low-noise analog supply voltage. Board noise and ground bouncing couple into the ADC and affect dynamic characteristics. Clean external reference must be used to achieve shown specs.
- t. Differential signal with correct common mode, applied between two ADC inputs.
- u. SDR = -THD in dB.
- v. For higher frequency inputs, degradation in SDR should be expected.
- w. SNDR = S/(N+D) = SINAD (in dB)
- x. Effective number of bits (ENOB) can be calculated from SNDR: ENOB = (SNDR - 1.76) / 6.02.
- y. Single ended inputs are more sensitive to board and trace noise than differential inputs; SNR and SNDR measurements on single-ended inputs are highly dependent on how clean the test set-up is. If the input signal is not well-isolated on the board, higher noise than specified could potentially be seen at the ADC output.

Figure 30-28. ADC External Reference Filtering

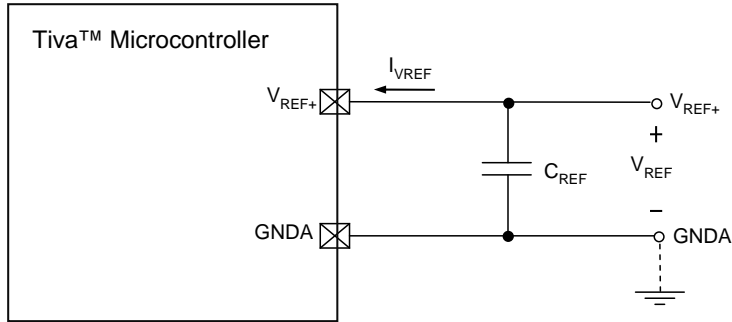
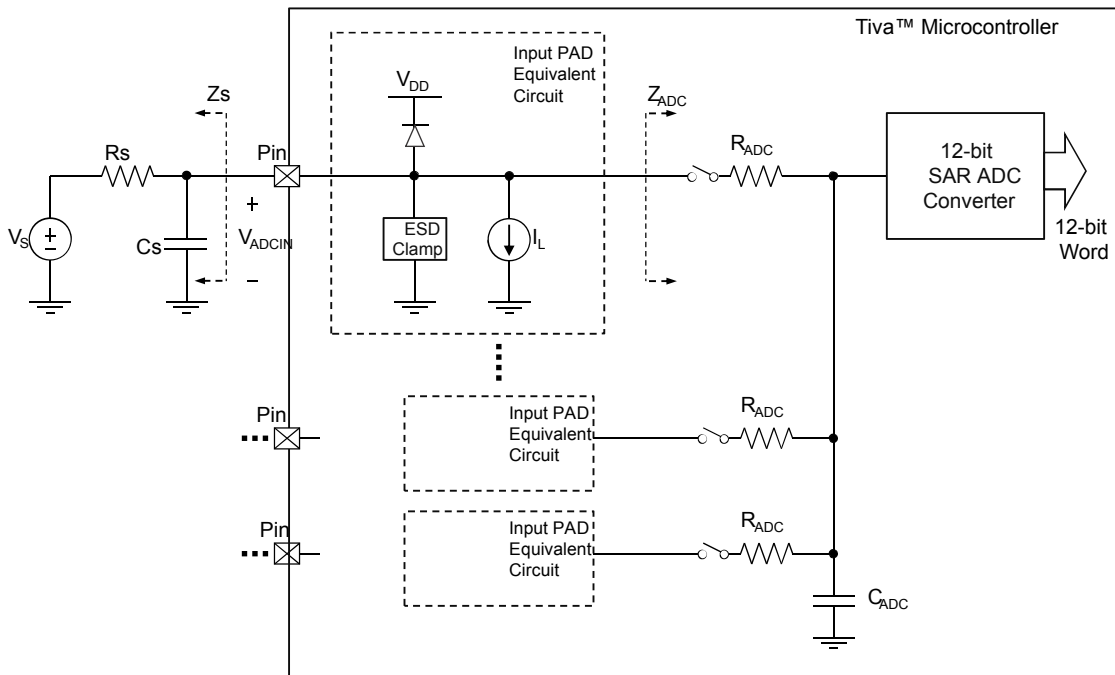

Figure 30-29. ADC Input Equivalency



30.17 Synchronous Serial Interface (SSI)

Table 30-46. SSI Characteristics

Parameter No.	Parameter	Parameter Name	Min	Nom	Max	Unit
S1	T _{CLK_PER}	SSIClk cycle time, as master ^a	16.67	-	-	ns
		SSIClk cycle time, as slave ^b	100	-	-	ns
S2	T _{CLK_HIGH}	SSIClk high time, as master	8.33	-	-	ns
		SSIClk high time, as slave	50	-	-	ns
S3	T _{CLK_LOW}	SSIClk low time, as master	8.33	-	-	ns
		SSIClk low time, as slave	50	-	-	ns
S4	T _{CLKR}	SSIClk rise time ^c	1.25	-	-	ns
S5	T _{CLKF}	SSIClk fall time ^c	1.25	-	-	ns
S6	T _{TXDMOV}	Master Mode: Master Tx Data Output (to slave) Valid Time from edge of SSIClk	-	-	4.00	ns
S7	T _{TXDMOH}	Master Mode: Master Tx Data Output (to slave) Hold Time after next SSIClk	0.60	-	-	ns
S8	T _{RXDMS}	Master Mode: Master Rx Data In (from slave) setup time	7.89	-	-	ns
S9	T _{RXDMH}	Master Mode: Master Rx Data In (from slave) hold time	0	-	-	ns
S10	T _{TXDSOV}	Slave Mode: Master Tx Data Output (to Master) Valid Time from edge of SSIClk	-	-	47.60 ^d	ns
S11	T _{TXDSOH}	Slave Mode: Slave Tx Data Output (to Master) Hold Time from next SSIClk	37.4 ^e	-	-	ns
S13	T _{RXDSSU}	Slave Mode: Rx Data In (from master) setup time	0	-	-	ns
S14	T _{RXDSh}	Slave Mode: Rx Data In (from master) hold time	37.03 ^f	-	-	ns

a. In master mode, the system clock must be at least twice as fast as the SSIClk.

b. In slave mode, the system clock must be at least 12 times faster than the SSIClk.

c. Note that the delays shown are using 12-mA drive strength.

d. This MAX value is for the minimum slave mode T_{SYSClk} period (8.33 ns). To find the MAX T_{TXDSOV} value for a larger T_{SYSClk}, use the equation: 4*T_{SYSClk}+14.25.

e. This MIN value is for the minimum slave mode T_{SYSClk} (8.33 ns). To find the MIN T_{TXDSOH} value for a larger T_{SYSClk}, use the equation: 4*T_{SYSClk}+4.08.

f. This MIN value is for the minimum slave mode T_{SYSClk} (8.33 ns). To find the MIN T_{TXDSh} value for a larger T_{SYSClk}, use the equation: 4*T_{SYSClk}+3.70.

Figure 30-30. SSI Timing for TI Frame Format (FRF=01), Single Transfer Timing Measurement



Figure 30-31. Master Mode SSI Timing for SPI Frame Format (FRF=00), with SPH=1

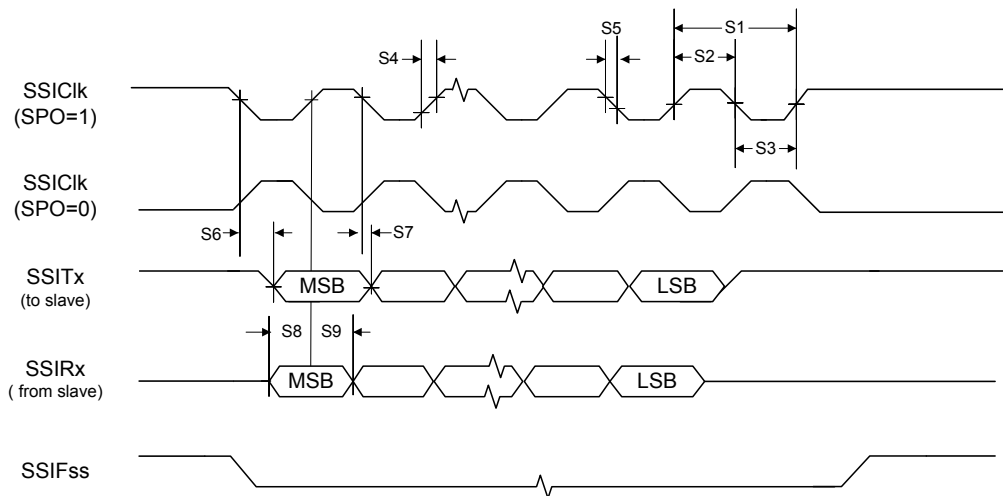
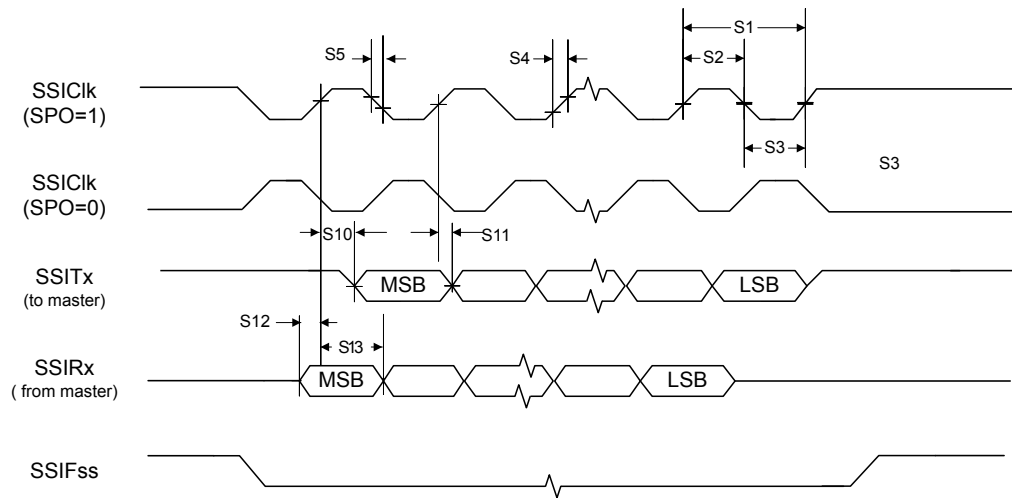

Figure 30-32. Slave Mode SSI Timing for SPI Frame Format (FRF=00), with SPH=1**Table 30-47. Bi- and Quad-SSI Characteristics^a**

Parameter No.	Parameter	Parameter Name	Min	Nom	Max	Unit
S15	T_{CLK_PER}	SSIClk cycle time, as master ^b	16.67	-	-	ns
S16	T_{CLK_HIGH}	SSIClk high time, as master	8.33	-	-	ns
S17	T_{CLK_LOW}	SSIClk low time, as master	8.33	-	-	ns
S18	T_{CLKR}	SSIClk rise time ^c	1.25	-	-	ns
S19	T_{CLKF}	SSIClk fall time ^c	1.25	-	-	ns
S20	T_{TXDMOV}	Master Mode: Master SSInXDATn Data Output (to slave) Valid Time from edge of SSIClk	-	-	4.04	ns
S21	T_{TXDMOH}	Master Mode: Master SSInXDATn Data Output (to slave) Hold Time after next SSIClk	0.60	-	-	ns
S22	T_{RXDMS}	Master Mode: Master SSInXDATn Data In (from slave) setup time	5.78	-	-	ns
S23	T_{RXDMH}	Master Mode: Master SSInXDATn Data In (from slave) hold time	0	-	-	ns

a. Parameters S15 through S23 correspond to parameters S1 through S9 in Figure 30-30 and Figure 30-31.

b. In master mode, the system clock must be at least twice as fast as the SSIClk.

c. Note that the delays shown are using 12-mA drive strength.

30.18 Inter-Integrated Circuit (I²C) Interface

Table 30-48. I²C Characteristics

Parameter No.	Parameter	Parameter Name	Min	Nom	Max	Unit
I1 ^a	T _{SCH}	Start condition hold time	36	-	-	system clocks
I2 ^a	T _{LP}	Clock Low period	36	-	-	system clocks
I3 ^b	T _{SRT}	I ² C _{SCL} /I ² C _{SDA} rise time (V _{IL} = 0.5 V to V _{IH} = 2.4 V)	-	-	(see note b)	ns
I4	T _{DH}	Data hold time (slave)	-	2	-	system clocks
		Data hold time (master)	-	7	-	system clocks
I5 ^c	T _{SFT}	I ² C _{SCL} /I ² C _{SDA} fall time (V _{IH} = 2.4 V to V _{IL} = 0.5 V)	-	9	10	ns
I6 ^a	T _{HT}	Clock High time	24	-	-	system clocks
I7	T _{DS}	Data setup time	18	-	-	system clocks
I8 ^a	T _{SCSR}	Start condition setup time (for repeated start condition only)	36	-	-	system clocks
I9 ^a	T _{SCS}	Stop condition setup time	24	-	-	system clocks
I10	T _{DV}	Data Valid (slave)	-	2	-	system clocks
		Data Valid (master)	-	(6 * (1 + TPR)) + 1	-	system clocks

- a. Values depend on the value programmed into the TPR bit in the I²C Master Timer Period (I2CMTPR) register; a TPR programmed for the maximum I²C_{SCL} frequency (TPR=0x2) results in a minimum output timing as shown in the table above. The I²C interface is designed to scale the actual data transition time to move it to the middle of the I²C_{SCL} Low period. The actual position is affected by the value programmed into the TPR; however, the numbers given in the above values are minimum values.
- b. Because I²C_{SCL} and I²C_{SDA} operate as open-drain-type signals, which the controller can only actively drive low, the time I²C_{SCL} or I²C_{SDA} takes to reach a high level depends on external signal capacitance and pull-up resistor values.
- c. Specified at a nominal 50 pF load.

Figure 30-33. I²C Timing

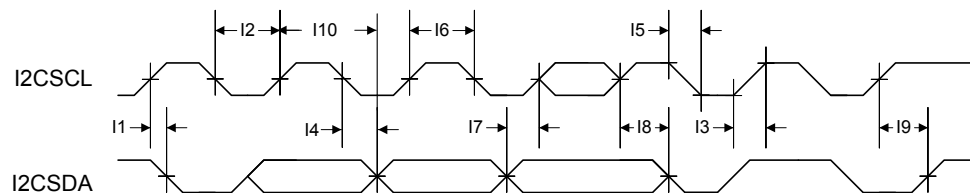

30.19 Ethernet Controller

30.19.1 DC Characteristics

The parameters listed in Table 30-49 on page 1995, with the exception of R_{BIAS} , apply to transmit pins of the Ethernet PHY, which are generally the $EN0TXOP$ and $EN0TXON$ signals during standard operation but can also be the $ENORXIN$ $ENORXIP$ signals if Auto-MDIX is enabled.

Table 30-49. Ethernet PHY DC Characteristics

Parameter	Parameter Name	Min	Nom	Max	Unit
R_{BIAS}	Value of the pull-down resistor on the R_{BIAS} pin	4.82	4.87	4.92	k Ω
V_{TPTD_100}	100M transmit voltage	0.95	1	1.05	V
$V_{TPTDSYM}$	100M transmit voltage symmetry	-2	-	2	%
V_{OVRSH}	Output overshoot	-	-	5	%
V_{TPTD_10}	10M transmit voltage	2.2	2.5	2.8	V
V_{TH1}	10Base-T Receive threshold	-	200	-	mV

30.19.2 Clock Characteristics

Table 30-50. MOSC 25-MHz Crystal Specification^a

Parameter No.	Parameter	Parameter Name	Min	Nom	Max	Unit
N1	F_{MOSC25}	Frequency	-	25	-	MHz
-	F_{TOL}	Frequency tolerance at operational temperature	0	-	± 50	ppm
-	T_{STA}	Frequency stability at 1-year aging	-	-	± 5	ppm

a. Refer to Table 30-23 on page 1962 for additional MOSC requirements.

Figure 30-34. MOSC Crystal Characteristics for Ethernet

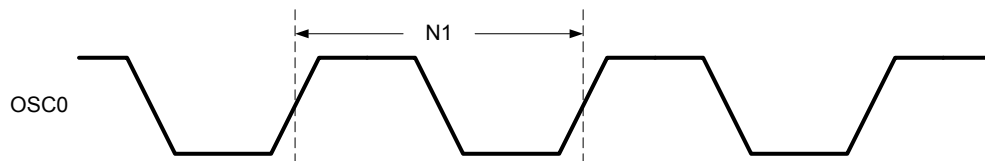

Table 30-51. MOSC Single-Ended 25-MHz Oscillator Specification^a

Parameter No.	Parameter	Parameter Name	Min	Nom	Max	Unit
N4	F_{OSC}	Frequency	-	25	-	MHz
-	F_{TOL}	Frequency tolerance at operational temperature	0	-	± 50	ppm
-	T_{STA}	Frequency stability at 1-year aging	-	-	± 50	ppm
N5	T_{RF}	Frequency rise and fall time	-	-	1	ns

Table 30-51. MOSC Single-Ended 25-MHz Oscillator Specification^a (continued)

Parameter No.	Parameter	Parameter Name	Min	Nom	Max	Unit
-	T _J	Jitter (cycle-to-cycle)	-	50	-	ps
		Jitter (over 10 ms)	-	-	1	ns
-	DC	Duty cycle	40	-	60	%

Figure 30-35. Single-Ended MOSC Characteristics for Ethernet

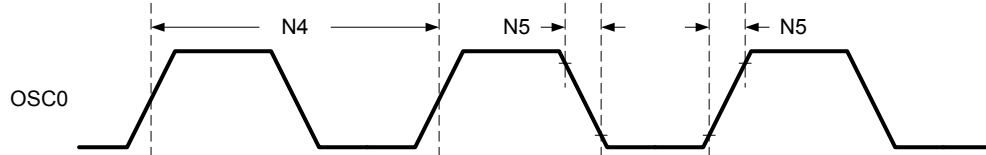

30.19.3 AC Characteristics

Table 30-52. Ethernet Controller Enable and Software Reset Timing

Parameter No.	Parameter	Parameter Name	Min	Nom	Max	Unit
N16	T _{EN}	Time from the System Control enable of the PHY to energy on the PMD output pin ^{ab}	45	-	-	μs
N17	T _{SWRST}	Time from software reset of the PHY to energy on the PMD output pin	110	-	-	ns

- a. The PHY is enabled through System Control by setting the P0 bit in the **PCEPHY** register and the R0 bit in the **RCGCPHY** register.
- b. This minimum timing assumes the **PHYHOLD** bit in the **EMACPC** register is not set.

Figure 30-36. Reset Timing

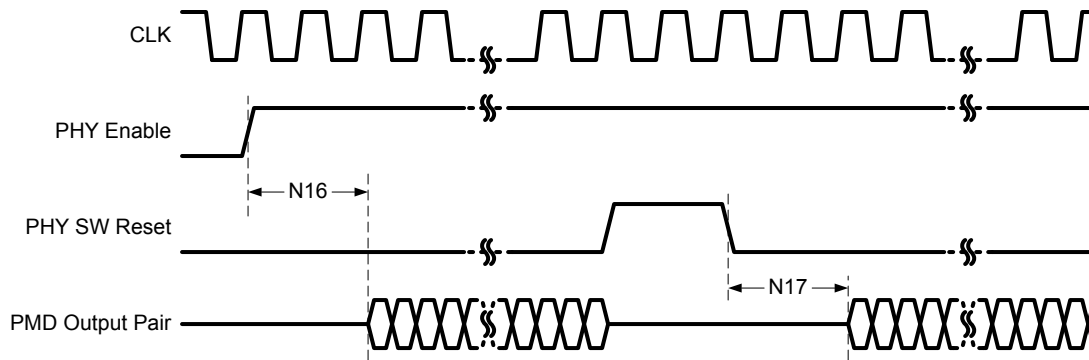

Table 30-53. 100Base-TX Transmit Timing (t_{R/F} and Jitter)

Parameter No.	Parameter	Parameter Name	Min	Nom	Max	Unit
N38	T _{RF}	100 Mb/s PMD output pair t _R and t _F ^a	3	4	5	ns
	T _{RF_MM}	100 Mb/s t _R and t _F symmetry ^{bc}	-	-	500	ps

Table 30-53. 100Base-TX Transmit Timing ($t_{R/F}$ and Jitter) (continued)

Parameter No.	Parameter	Parameter Name	Min	Nom	Max	Unit
N39	T_{RF_JTTR}	100 Mb/s PMD Output Pair Transmit Jitter	-	-	1.4	ns

- a. Rise and fall times taken at 10% and 90% of the +1 or -1 amplitude.
 b. Normal mismatch is the difference between the maximum and minimum of all rise and fall times
 c. Choice of Ethernet transformer magnetics can affect this parameter.

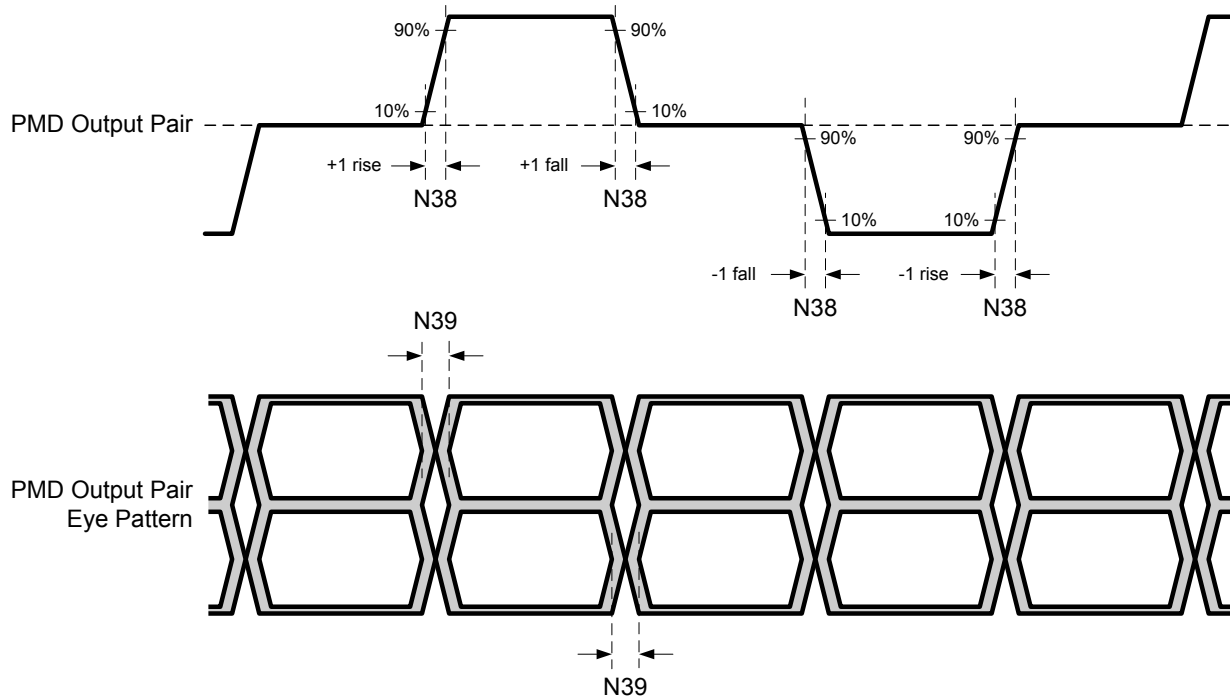
Figure 30-37. 100 Base-TX Transmit Timing**Table 30-54. 10Base-T Normal Link Pulse Timing**

Parameter No.	Parameter	Parameter Name	Min	Nom	Max	Unit
N69	T_{LP_PER}	Link pulse period	-	76	-	ms
N70	T_{LP_WID}	Link pulse width	-	100	-	μ s

Figure 30-38. 10Base-TX Normal Link Pulse Timing

Table 30-55. Auto-Negotiation Fast Link Pulse (FLP) Timing

Parameter No.	Parameter	Parameter Name	Min	Nom	Max	Unit
N72	T_{CLKP}	Clock pulse to clock pulse period	-	125	-	μs
N73	T_{CLKDP}	Clock Pulse to Data Pulse Period	-	62	-	μs
N74	T_{PUL}	Clock, Data Pulse Width	-	110	-	ns
N75	T_{BRSTP}	FLP Burst to FLP Burst Period	-	16	-	ms
N76	T_{BRSTW}	Burst Width	-	2	-	ms

Figure 30-39. Auto-Negotiation Fast Link Pulse Timing

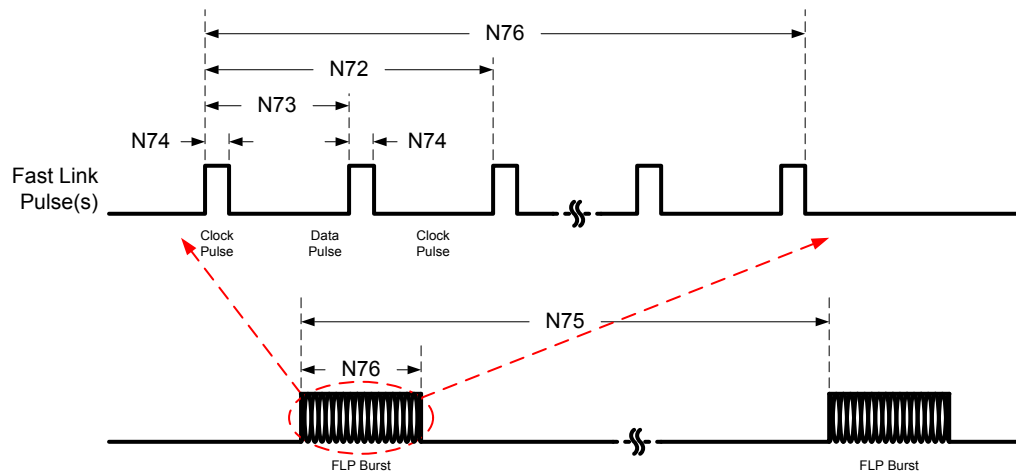
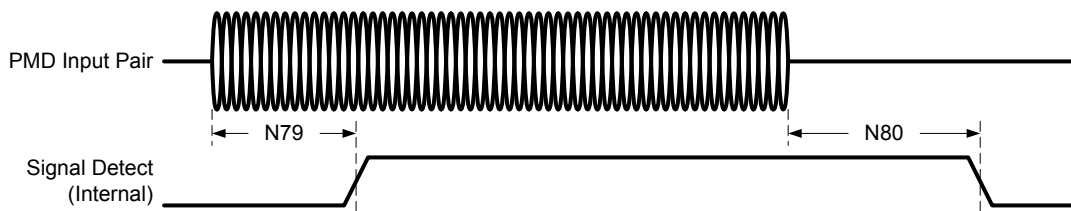

Table 30-56. 100Base-TX Signal Detect Timing

Parameter No.	Parameter	Parameter Name	Min	Nom	Max	Unit
N79	T_{ON}	SD Internal Turn-on Time	-	-	100	μs
N80	T_{OFF}	Internal Turn-off Time	-	-	200	μs

Figure 30-40. 100Base-TX Signal Detect Timing



30.20 Universal Serial Bus (USB) Controller

The Tiva™ C Series USB controller electrical specifications are compliant with the *Universal Serial Bus Specification Rev. 2.0* (full-speed and low-speed support) and the *On-The-Go Supplement to the USB 2.0 Specification Rev. 1.0*. Some components of the USB system are integrated within the TM4C129ENC PDT microcontroller and specific to the Tiva™ C Series microcontroller design.

Note: GPIO pin, PB1, which can be configured as the USB0VBUS signal, is the only pin which is 5-V tolerant on the device.

Table 30-57. ULPI Interface Timing

Parameter No.	Parameter	Parameter Name	Min	Nom	Max	Unit
Timings with respect to external clock source input to USB0CLK						
U1	T _{SUC}	Setup time (control in) USB0DIR, USB0NXT	4.8	-	-	ns
U2	T _{SUD}	Setup Time (data in) USB0Dn	3.5	-	-	ns
U3	T _{HTC}	Hold Time (control in) USB0DIR, USB0NXT	0	-	-	ns
U4	T _{HTD}	Hold Time (data in) USB0Dn	0	-	-	ns
U5	T _{ODC}	Output Delay (control out) USB0STP	3.7	-	9.5	ns
U6	T _{ODD}	Output Delay (data out) USB0Dn	3.7	-	9.5	ns
Timings with USB0CLK as clock output						
U1	T _{SUC}	Setup time (control in) USB0DIR, USB0NXT	6.0	-	-	ns
U2	T _{SUD}	Setup Time (data in) USB0Dn	4.6	-	-	ns
U3	T _{HTC}	Hold Time (control in) USB0DIR, USB0NXT	0	-	-	ns
U4	T _{HTD}	Hold Time (data in) USB0Dn	0	-	-	ns
U5	T _{ODC}	Output Delay (control out) USB0STP	4.0	-	10.6	ns
U6	T _{ODD}	Output Delay (data out) USB0Dn	4.0	-	10.6	ns

Figure 30-41. ULPI Interface Timing Diagram

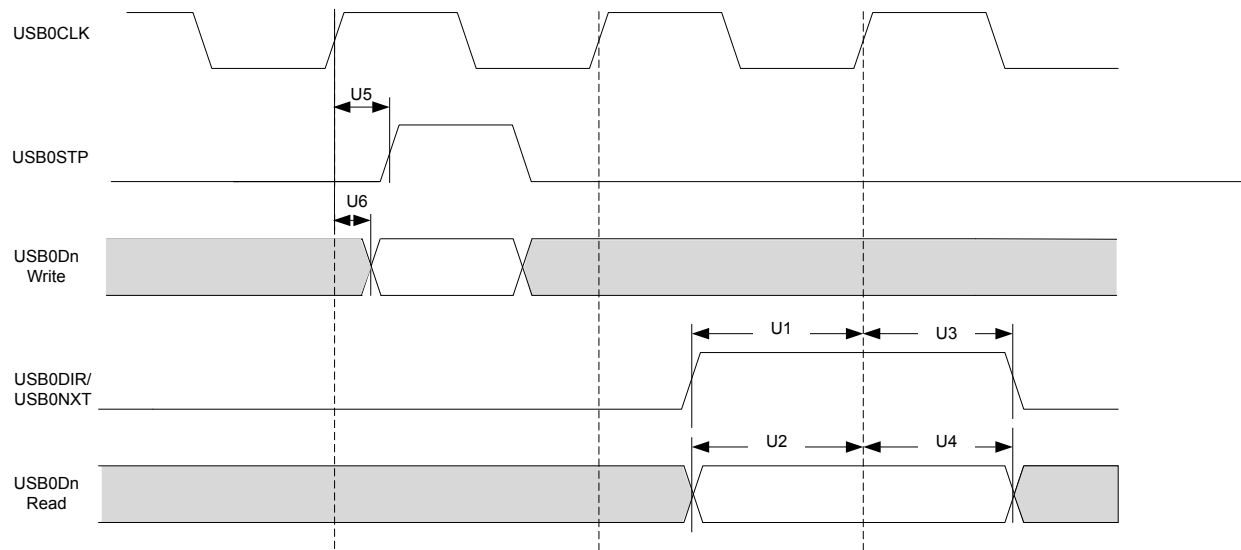

30.21 Analog Comparator

Table 30-58. Analog Comparator Characteristics^{ab}

Parameter	Parameter Name	Min	Nom	Max	Unit
V_{INP}, V_{INN}^c	Input voltage range	GNDA	-	V_{DDA}	V
V_{CM}	Input common mode voltage range	GNDA	-	V_{DDA}	V
V_{OS}	Input offset voltage	-	± 10	$\pm 50^d$	mV
I_{INP}, I_{INN}	Input leakage current over full voltage range	-	-	2.0	μA
C_{MRR}	Common mode rejection ratio	-	50	-	dB
T_{RT}	Response time	-	-	1.0^e	μs
T_{MC}	Comparator mode change to Output Valid	-	-	10	μs

a. Best design practices suggest that static or quiet digital I/O signals be configured adjacent to sensitive analog inputs to reduce capacitive coupling and cross talk.

b. To achieve best analog results, the source resistance driving the analog inputs, V_{INP} and V_{INN} , should be kept low.

c. The external voltage inputs to the Analog Comparator are designed to be highly sensitive and can be affected by external noise on the board. For this reason, V_{INP} and V_{INN} must be set to different voltage levels during idle states to ensure the analog comparator triggers are not enabled. If an internal voltage reference is used, it should be set to a mid-supply level. When operating in Sleep/Deep-Sleep modes, the Analog Comparator module should be disabled or the external voltage inputs set to different levels (greater than the input offset voltage) to achieve minimum current draw.

d. Measured at $V_{REF}=100$ mV.

e. Measured at external $V_{REF}=100$ mV, input signal switching from 75 mV to 125 mV.

Table 30-59. Analog Comparator Voltage Reference Characteristics

Parameter	Parameter Name	Min	Nom	Max	Unit
R_{HR}	Resolution in high range	-	$V_{DDA}/29.4$	-	V
R_{LR}	Resolution in low range	-	$V_{DDA}/22.12$	-	V
A_{HR}	Absolute accuracy high range	-	-	$\pm R_{HR}/2$	V
A_{LR}	Absolute accuracy low range	-	-	$\pm R_{LR}/2$	V

Table 30-60. Analog Comparator Voltage Reference Characteristics, $V_{DDA} = 3.3V$, $EN = 1$, and $RNG = 0$

V_{REF} Value	V_{IREF} Min	Ideal V_{IREF}	V_{IREF} Max	Unit
0x0	0.731	0.786	0.841	V
0x1	0.843	0.898	0.953	V
0x2	0.955	1.010	1.065	V
0x3	1.067	1.122	1.178	V
0x4	1.180	1.235	1.290	V
0x5	1.292	1.347	1.402	V
0x6	1.404	1.459	1.514	V
0x7	1.516	1.571	1.627	V
0x8	1.629	1.684	1.739	V
0x9	1.741	1.796	1.851	V
0xA	1.853	1.908	1.963	V
0xB	1.965	2.020	2.076	V
0xC	2.078	2.133	2.188	V

Table 30-60. Analog Comparator Voltage Reference Characteristics, $V_{DDA} = 3.3V$, $EN = 1$, and $RNG = 0$ (continued)

V_{REF} Value	V_{IREF} Min	Ideal V_{IREF}	V_{IREF} Max	Unit
0xD	2.190	2.245	2.300	V
0xE	2.302	2.357	2.412	V
0xF	2.414	2.469	2.525	V

Table 30-61. Analog Comparator Voltage Reference Characteristics, $V_{DDA} = 3.3V$, $EN = 1$, and $RNG = 1$

V_{REF} Value	V_{IREF} Min	Ideal V_{IREF}	V_{IREF} Max	Unit
0x0	0.000	0.000	0.074	V
0x1	0.076	0.149	0.223	V
0x2	0.225	0.298	0.372	V
0x3	0.374	0.448	0.521	V
0x4	0.523	0.597	0.670	V
0x5	0.672	0.746	0.820	V
0x6	0.822	0.895	0.969	V
0x7	0.971	1.044	1.118	V
0x8	1.120	1.193	1.267	V
0x9	1.269	1.343	1.416	V
0xA	1.418	1.492	1.565	V
0xB	1.567	1.641	1.715	V
0xC	1.717	1.790	1.864	V
0xD	1.866	1.939	2.013	V
0xE	2.015	2.089	2.162	V
0xF	2.164	2.238	2.311	V

30.22 Pulse-Width Modulator (PWM)

Table 30-62. PWM Timing Characteristics

Parameter	Parameter Name	Min	Nom	Max	Unit
T_{FLTW}	Minimum Fault Pulse Width	2	-	-	PWM clock periods
T_{FLTMAX}	$MnFAULTn$ Assertion to PWM Inactive ^a	-	-	24 + (1 PWM clock)	ns
T_{FLTMIN}	$MnFAULTn$ De-Assertion to PWM Active ^b	5	-	-	ns

a. This parameter value can vary depending on the PWM clock frequency which is controlled by the System Clock and a programmable divider field in the **PWMCC** register.

b. The latch and minimum fault period functions that can be enabled in the **PWMnCTL** register can change the timing of this parameter.

30.23 Current Consumption

Table 30-64 on page 2008 shows the amount of current consumption that specific peripherals contribute to the Run mode current consumption numbers shown in Table 30-63 on page 2004. If these peripherals are not powered, then the peripheral current consumption values can be subtracted from the Run mode numbers displayed in Table 30-63 on page 2004.

Table 30-63. Current Consumption^{ab}

Parameter	Parameter Name	Conditions	System Clock		Nom				Max		Unit
			Frequency	Clock Source	-40°C	25°C	85°C	105°C ^c	85°C	105°C ^c	
I_{DD_RUN}	Run mode (Flash loop)	$V_{DD} = 3.3\text{ V}$ $V_{DDA} = 3.3\text{ V}$ Peripherals = All ON including MAC and PHY	120 MHz	MOSC with PLL	96.4	105.3	107.2	108.7	129.9	140.0	mA
			60 MHz	MOSC with PLL	67.4	76.6	78.6	79.9	100.3	112.5	mA
			16 MHz	PIOSC	11.9	24.4	25.5	26.7	45.0	56.4	mA
			1 MHz	PIOSC	5.75	10.9	12.1	13.3	31.3	42.6	mA
		$V_{DD} = 3.3\text{ V}$ $V_{DDA} = 3.3\text{ V}$ Peripherals = All ON including MAC but not PHY	120 MHz	MOSC with PLL	69.9	77.8	79.6	80.8	98.8	108.4	mA
			60 MHz	MOSC with PLL	40.9	49.2	50.9	52.1	69.2	80.8	mA
			16 MHz	PIOSC	11.3	23.6	25.0	26.2	43.1	54.3	mA
			1 MHz	PIOSC	5.10	10.1	11.5	12.7	29.3	40.5	mA
		$V_{DD} = 3.3\text{ V}$ $V_{DDA} = 3.3\text{ V}$ Peripherals = All ON except MAC/PHY	120 MHz	MOSC with PLL	68.1	76.0	77.6	78.6	96.6	106.0	mA
			60 MHz	MOSC with PLL	40.0	48.2	49.8	50.8	67.9	79.2	mA
			16 MHz	PIOSC	11.1	23.3	24.6	25.6	42.5	53.3	mA
			1 MHz	PIOSC	5.07	10.1	11.3	12.3	29.0	39.8	mA
		$V_{DD} = 3.3\text{ V}$ $V_{DDA} = 3.3\text{ V}$ Peripherals = All OFF	120 MHz	MOSC with PLL	35.2	39.1	40.4	41.5	55.8	65.3	mA
			60 MHz	MOSC with PLL	23.2	29.4	30.7	31.7	45.8	55.5	mA
			16 MHz	PIOSC	7.38	17.9	19.0	20.0	34.5	44.1	mA
			1 MHz	PIOSC	4.12	9.13	10.3	11.4	25.7	35.5	mA
	Run mode (SRAM loop)	$V_{DD} = 3.3\text{ V}$ $V_{DDA} = 3.3\text{ V}$ Peripherals = All ON including MAC and PHY	120 MHz	MOSC with PLL	93.8	103.6	111.6	113.2	133.4	144.6	mA
			60 MHz	MOSC with PLL	66.9	76.7	78.7	80.0	100.0	111.9	mA
			16 MHz	PIOSC	12.6	19.0	20.1	21.3	39.1	50.3	mA
			1 MHz	PIOSC	5.73	10.6	11.7	12.8	30.9	42.2	mA
$V_{DD} = 3.3\text{ V}$ $V_{DDA} = 3.3\text{ V}$ Peripherals = All ON including MAC but not PHY		120 MHz	MOSC with PLL	67.2	76.1	84.0	85.4	102.3	113.0	mA	
		60 MHz	MOSC with PLL	40.3	49.2	50.9	52.2	68.9	80.2	mA	
		16 MHz	PIOSC	11.9	18.2	19.6	20.8	37.2	48.2	mA	
		1 MHz	PIOSC	5.08	9.79	11.2	12.3	28.9	40.1	mA	
$V_{DD} = 3.3\text{ V}$ $V_{DDA} = 3.3\text{ V}$		120 MHz	MOSC with PLL	65.4	74.3	82.0	83.2	100.1	110.6	mA	

Table 30-63. Current Consumption (continued)

Parameter	Parameter Name	Conditions	System Clock		Nom				Max		Unit					
			Frequency	Clock Source	-40°C	25°C	85°C	105°C ^C	85°C	105°C ^C						
		Peripherals = All ON except MAC/PHY	60 MHz	MOSC with PLL	39.4	48.2	49.8	50.9	67.6	78.6	mA					
			16 MHz	PIOSC	11.7	17.9	19.2	20.2	36.6	47.2	mA					
			1 MHz	PIOSC	5.05	9.75	11.0	11.9	28.6	39.4	mA					
		V _{DD} = 3.3 V V _{DDA} = 3.3 V Peripherals = All OFF			120 MHz	MOSC with PLL	35.4	43.3	44.7	45.8	59.8	69.0	mA			
					60 MHz	MOSC with PLL	23.4	29.4	30.7	31.7	45.5	54.9	mA			
					16 MHz	PIOSC	7.08	12.4	13.6	14.6	28.7	38.0	mA			
					1 MHz	PIOSC	4.60	8.78	10.0	11.0	25.3	34.9	mA			
					I _{DD_SLEEP}	Sleep mode (FLASHPM = 0x0)	V _{DD} = 3.3 V V _{DDA} = 3.3 V Peripherals = All ON including MAC and PHY LDO = 1.2 V	120 MHz	MOSC with PLL	82.8	94.8	96.8	98.1	117.9	129.1	mA
								60 MHz	MOSC with PLL	60.8	69.2	71.2	72.3	91.8	102.9	mA
		16 MHz	PIOSC ^d	11.2				16.8	18.1	19.1	35.4	45.9	mA			
		1 MHz	PIOSC ^d	5.10				10.3	11.5	12.6	28.9	39.6	mA			
		V _{DD} = 3.3 V V _{DDA} = 3.3 V Peripherals = All ON including MAC but not PHY LDO = 1.2 V					120 MHz	MOSC with PLL	56.2	67.4	69.1	70.3	87.1	97.8	mA	
60 MHz	MOSC with PLL						34.4	41.9	43.4	44.5	60.7	71.6	mA			
16 MHz	PIOSC ^d						10.6	16.2	17.5	18.5	34.5	45.1	mA			
1 MHz	PIOSC ^d						4.47	9.60	10.9	12.0	28.0	38.7	mA			
V _{DD} = 3.3 V V _{DDA} = 3.3 V Peripherals = All ON except MAC/PHY LDO = 1.2 V			120 MHz	MOSC with PLL			54.4	65.6	67.1	68.1	84.9	95.4	mA			
			60 MHz	MOSC with PLL			33.5	40.9	42.3	43.2	59.4	70.0	mA			
			16 MHz	PIOSC ^d			10.4	15.9	17.1	17.9	33.9	44.1	mA			
			1 MHz	PIOSC ^d			4.44	9.56	10.7	11.6	27.7	38.0	mA			
V _{DD} = 3.3 V V _{DDA} = 3.3 V Peripherals = All OFF LDO = 1.2 V			120 MHz	MOSC with PLL	22.0	28.6	29.8	30.7	44.1	53.1	mA					
			60 MHz	MOSC with PLL	16.3	22.0	23.2	24.1	37.5	46.6	mA					
			16 MHz	PIOSC ^d	5.37	10.4	11.5	12.4	26.1	35.1	mA					
			1 MHz	PIOSC ^d	4.37	8.60	9.71	10.6	24.6	33.9	mA					
I _{DD_SLEEP}	Sleep mode (FLASHPM = 0x2)	V _{DD} = 3.3 V V _{DDA} = 3.3 V Peripherals = All ON including MAC and PHY LDO = 1.2 V	120 MHz	MOSC with PLL	86.5	89.0	91.2	92.5	112.1	123.5	mA					
			60 MHz	MOSC with PLL	61.6	63.4	65.6	66.7	86.0	97.2	mA					
			16 MHz	PIOSC ^d	10.4	11.1	12.4	13.5	29.8	40.4	mA					
			1 MHz	PIOSC ^d	4.45	4.49	5.83	6.98	23.4	34.2	mA					
		V _{DD} = 3.3 V V _{DDA} = 3.3 V			120 MHz	MOSC with PLL	59.9	61.7	63.4	64.7	81.3	92.1	mA			
					60 MHz	MOSC with PLL	35.1	36.1	37.8	38.9	54.9	66.0	mA			

Table 30-63. Current Consumption (continued)

Parameter	Parameter Name	Conditions	System Clock		Nom				Max		Unit
			Frequency	Clock Source	-40°C	25°C	85°C	105°C ^c	85°C	105°C ^c	
		Peripherals = All ON including MAC but not PHY LDO = 1.2 V	16 MHz	PIOSC ^d	9.75	10.4	11.8	12.9	28.9	39.6	mA
			1 MHz	PIOSC ^d	3.82	3.82	5.25	6.38	22.5	33.4	mA
		V _{DD} = 3.3 V V _{DDA} = 3.3 V Peripherals = All ON except MAC/PHY LDO = 1.2 V	120 MHz	MOSC with PLL	58.1	59.9	61.4	62.5	79.1	89.7	mA
			60 MHz	MOSC with PLL	34.2	35.1	36.7	37.6	53.6	64.4	mA
			16 MHz	PIOSC ^d	9.50	10.1	11.4	12.3	28.3	38.6	mA
			1 MHz	PIOSC ^d	3.79	3.78	5.06	5.96	22.2	32.7	mA
		V _{DD} = 3.3 V V _{DDA} = 3.3 V Peripherals = All OFF LDO = 1.2 V	120 MHz	MOSC with PLL	22.0	22.8	24.1	25.1	38.2	47.4	mA
			60 MHz	MOSC with PLL	15.7	16.2	17.5	18.5	31.7	40.9	mA
			16 MHz	PIOSC ^d	4.50	4.60	5.80	6.80	20.5	29.8	mA
			1 MHz	PIOSC ^d	3.00	2.80	4.10	5.20	19.1	28.7	mA
I _{DD_DEEPSLEEP} ^e	Deep-Sleep mode (FLASHPM = 0x2)	V _{DD} = 3.3 V V _{DDA} = 3.3 V Peripherals = All ON LDO = 1.2 V	16 MHz	PIOSC	9.74	9.78	10.8	11.6	24.1	32.1	mA
			30 kHz	LFIOSC	2.60	2.83	3.83	4.60	17.1	25.3	mA
		V _{DD} = 3.3 V V _{DDA} = 3.3 V Peripherals = All OFF LDO = 1.2 V	16 MHz	PIOSC	4.53	4.05	4.88	5.53	15.9	22.7	mA
			30 kHz	LFIOSC	0.614	0.762	1.69	2.46	13.3	20.7	mA
		V _{DD} = 3.3 V V _{DDA} = 3.3 V Peripherals = All ON LDO = 0.9 V ^f	16 MHz	PIOSC	5.21	7.33	7.97	8.48	15.3	20.1	mA
			30 kHz	LFIOSC	2.02	2.16	2.79	3.29	10.0	14.9	mA
		V _{DD} = 3.3 V V _{DDA} = 3.3 V Peripherals = All OFF LDO = 0.9 V ^f	16 MHz	PIOSC	1.08	3.10	3.61	4.01	9.50	13.4	mA
			30 kHz	LFIOSC	0.367	0.454	0.954	1.36	6.86	10.8	mA
I _{DDA_RUN} I _{DDA_SLEEP}	All Run modes All Sleep modes	V _{DD} = 3.3 V V _{DDA} = 3.3 V Peripherals = All ON	120 MHz	MOSC with PLL	2.61	2.66	2.68	2.66	3.03	3.35	mA
			60 MHz	MOSC with PLL	2.61	2.66	2.68	2.66	3.04	3.10	mA
			16 MHz	PIOSC	2.45	2.49	2.50	2.48	2.85	2.95	mA
			1 MHz	PIOSC	2.45	2.48	2.50	2.48	2.84	2.90	mA
		V _{DD} = 3.3 V V _{DDA} = 3.3 V Peripherals = All OFF	120 MHz	MOSC with PLL	0.227	0.229	0.270	0.250	0.559	0.650	mA
			60 MHz	MOSC with PLL	0.229	0.232	0.267	0.250	0.579	0.600	mA
			16 MHz	PIOSC	0.228	0.229	0.265	0.251	0.545	0.575	mA
			1 MHz	PIOSC	0.227	0.227	0.267	0.247	0.549	0.555	mA

Table 30-63. Current Consumption (continued)

Parameter	Parameter Name	Conditions	System Clock		Nom				Max		Unit
			Frequency	Clock Source	-40°C	25°C	85°C	105°C ^C	85°C	105°C ^C	
I _{DDA_DEEPSLEEP}	Deep-Sleep mode (FLASHPM = 0x2)	V _{DD} = 3.3 V V _{DDA} = 3.3 V Peripherals = All ON LDO = 1.2 V	16 MHz	PIOSC	2.45	2.48	2.50	2.48	2.84	2.90	mA
			30 kHz	LFIOSC	2.45	2.48	2.50	2.48	2.85	2.90	mA
		V _{DD} = 3.3 V V _{DDA} = 3.3 V Peripherals = All OFF LDO = 1.2 V	16 MHz	PIOSC	0.226	0.227	0.265	0.249	0.558	0.635	mA
			30 kHz	LFIOSC	0.228	0.227	0.272	0.247	0.558	0.600	mA
		V _{DD} = 3.3 V V _{DDA} = 3.3 V Peripherals = All ON LDO = 0.9 V ^f	16 MHz	PIOSC	2.14	2.42	2.44	2.42	2.78	2.88	mA
			30 kHz	LFIOSC	2.44	2.42	2.44	2.42	2.86	2.88	mA
		V _{DD} = 3.3 V V _{DDA} = 3.3 V Peripherals = All OFF LDO = 0.9 V ^f	16 MHz	PIOSC	0.216	0.166	0.209	0.193	0.563	0.580	mA
			30 kHz	LFIOSC	0.223	0.167	0.209	0.189	0.508	0.580	mA
I _{HIB_NORTC}	Hibernate mode (external wake, RTC disabled)	V _{BAT} = 3.0 V V _{DD} = 0 V V _{DDA} = 0 V System Clock = OFF Hibernate Module = 32.768 kHz	-	-	1.04	1.20	1.44	1.69	1.62	2.14	μA
I _{HIB_RTC}	Hibernate mode (RTC enabled)	V _{BAT} = 3.0 V V _{DD} = 0 V V _{DDA} = 0 V System Clock = OFF Hibernate Module = 32.768 kHz	-	-	1.12	1.29	1.54	1.82	1.75	2.33	μA
I _{HIB_VDD3ON}	Hibernate mode (VDD3ON mode, Tamper enabled)	V _{BAT} = 3.0 V V _{DD} = 3.3 V V _{DDA} = 3.3 V System Clock = OFF Hibernate Module = 32.768 kHz	-	-	6.78	7.99	17.0	22.1	31.0	46.2	μA
	Hibernate mode (VDD3ON mode, Tamper disabled)	V _{BAT} = 3.0 V V _{DD} = 3.3 V V _{DDA} = 3.3 V System Clock = OFF Hibernate Module = 32.768 kHz	-	-	5.42	6.39	15.4	17.8	28.9	32.0	μA

a. Total current in RUN, SLEEP and DEEPSLEEP modes is the sum of I_{DD} and I_{DDA}.

b. For Peripherals = All OFF, the clocks to all peripherals are turned off and the peripherals are powered down, if capable (see the section called "Peripheral Power Control" on page 250).

c. Applicable to extended temperature devices only.

- d. Note that if the MOSC is the source of the Run-mode system clock and is powered down in Sleep mode, wake time is increased by T_{MOSC_SETTLE} .
- e. To achieve the lowest possible Deep-Sleep current, one or more wait states must be configured in the **MEMTIMO** register. If there are no wait states applied in Run mode, then lowest possible Deep-Sleep current is not achieved.
- f. See the section called "LDO Power Control" on page 251 for information on lowering the LDO voltage to 0.9 V.

Table 30-64. Peripheral Current Consumption

Parameter	Parameter Name	Conditions	System Clock	Nom	Units
I_{DDUSB}	USB (including USB PHY) run mode current	$V_{DD} = 3.3\text{ V}$ $V_{DDA} = 3.3\text{ V}$	120 MHz (MOSC with PLL)	4.0	mA
$I_{DDEMACPHY}$	Ethernet MAC and PHY run mode current	$V_{DD} = 3.3\text{ V}$ $V_{DDA} = 3.3\text{ V}$	120 MHz (MOSC with PLL)	30	mA

A Package Information

A.1 Orderable Devices

The figure below defines the full set of orderable part numbers for the TM4C129x Series. See the Package Option Addendum for the complete list of valid orderable part numbers for the TM4C129ENCPDT microcontroller.

Figure A-1. Key to Part Numbers

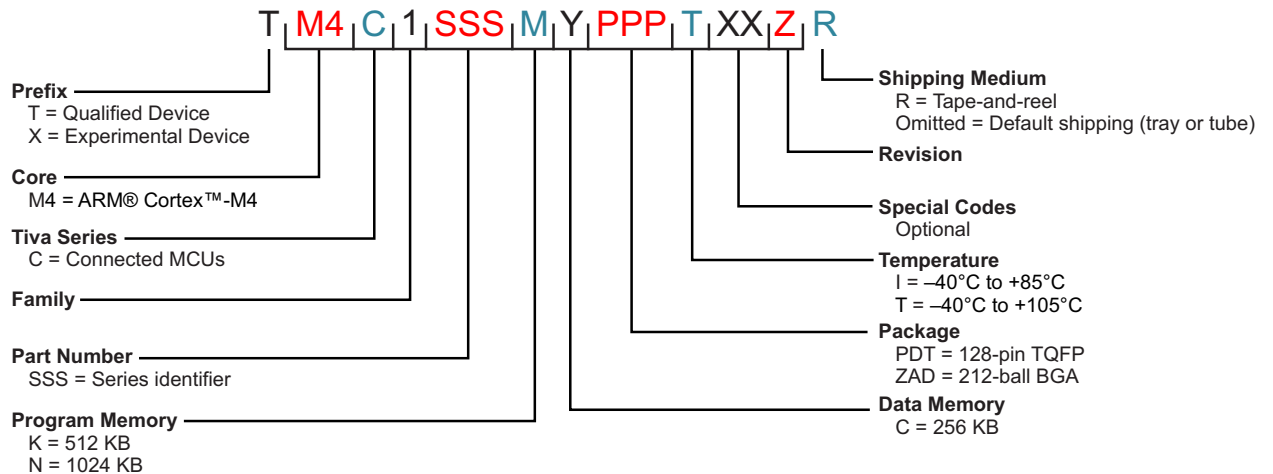

A.2 Device Nomenclature

To designate the stages in the product development cycle, TI assigns prefixes to the part numbers of all microcontroller (MCU) devices. Each Tiva™ C Series family member has one of two prefixes: XM4C or TM4C. These prefixes represent evolutionary stages of product development from engineering prototypes (XM4C) through fully qualified production devices (TM4C).

Device development evolutionary flow:

- XM4C — Experimental device that is not necessarily representative of the final device's electrical specifications and may not use production assembly flow.
- TM4C — Production version of the silicon die that is fully qualified.

XM4C devices are shipped against the following disclaimer:

"Developmental product is intended for internal evaluation purposes."

TM4C devices have been characterized fully, and the quality and reliability of the device have been demonstrated fully. TI's standard warranty applies.

Predictions show that prototype devices (XM4C) have a greater failure rate than the standard production devices. Texas Instruments recommends that these devices not be used in any production system because their expected end-use failure rate still is undefined. Only qualified production devices are to be used.

A.3 Device Markings

The figure below shows an example of the Tiva™ microcontroller package symbolization.

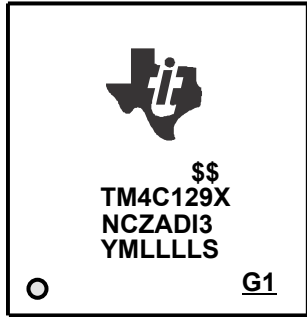

This identifying number contains the following information:

- **Lines 1 and 5:** Internal tracking numbers
- **Lines 2 and 3:** Part number

For example, TM4C129X on the second line followed by NCZADI3 on the third line indicates orderable part number TM4C129XNCZADI3. Note that the first letter in the part number indicates the product status. A T indicates the part is fully qualified and released to production; an X indicates the part is experimental (pre-production) and requires a waiver. The silicon revision number is the last number in the part number, in this example, 3. The **DID0** register identifies the version of the microcontroller, as shown in the table below. Combined, the MAJOR and MINOR bit fields indicate the die revision and part revision numbers.

MAJOR Bitfield Value	MINOR Bitfield Value	Die Revision	Part Revision
0x0	0x0	A0	1
0x0	0x1	A1	2
0x0	0x2	A2	3

- **Line 4:** Date code

The first two characters on the fourth line indicate the date code, followed by internal tracking numbers. The two-digit date code YM indicates the last digit of the year, then the month. For example, a 34 for the first two digits of the fourth line indicates a date code of April 2013.

A.4 Packaging Diagram

Figure A-2. TM4C129ENCPDT 128-Pin TQFP Package Diagram

MECHANICAL DATA

MPQF013 – NOVEMBER 1995

PDT (S-PQFP-G128)

PLASTIC QUAD FLATPACK

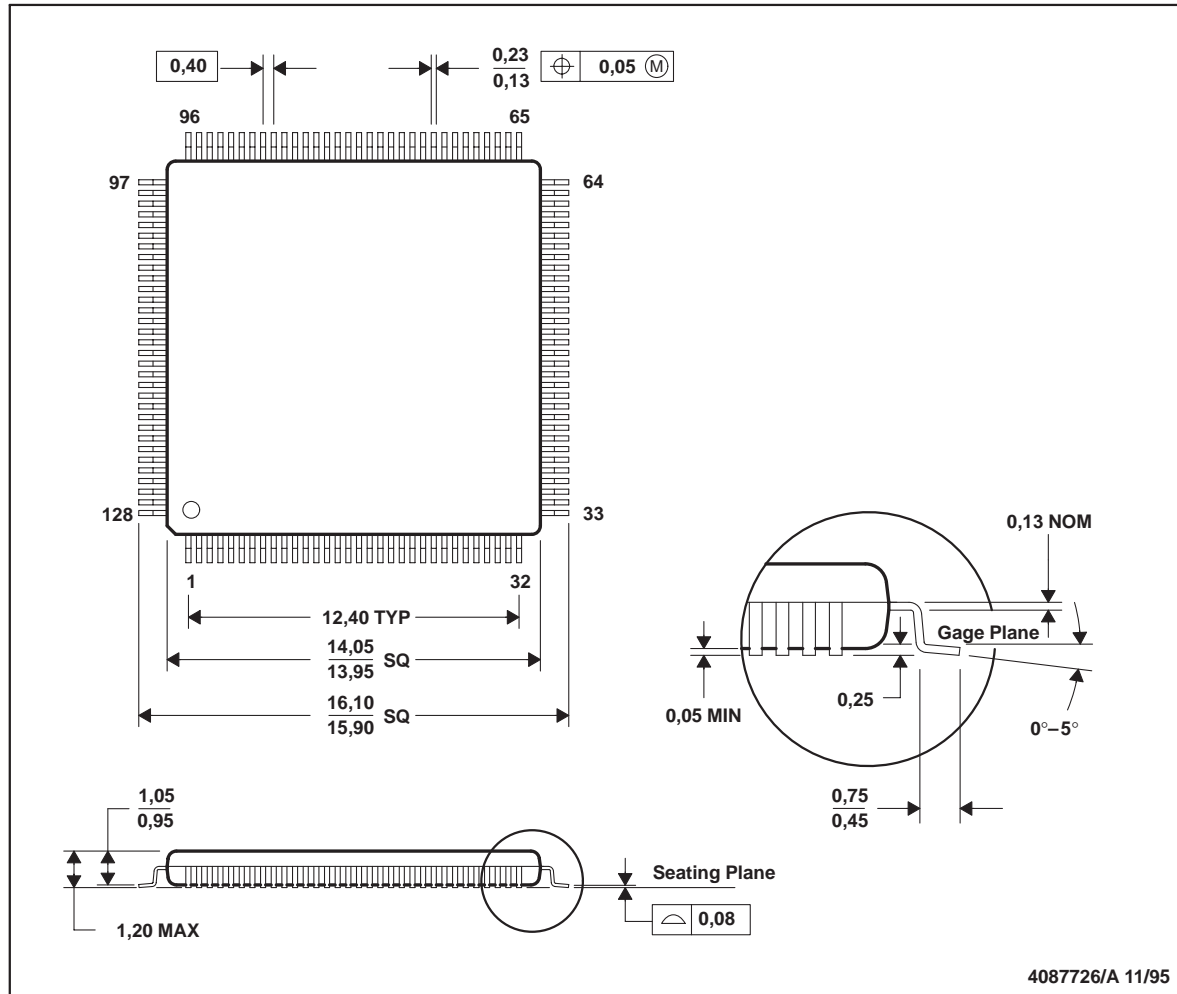

- NOTES: A. All linear dimensions are in millimeters.
 B. This drawing is subject to change without notice.

PACKAGING INFORMATION

Orderable part number	Status (1)	Material type (2)	Package Pins	Package qty Carrier	RoHS (3)	Lead finish/ Ball material (4)	MSL rating/ Peak reflow (5)	Op temp (°C)	Part marking (6)
TM4C129ENCPDTI3	Active	Production	TQFP (PDT) 128	90 JEDEC TRAY (5+1)	Yes	NIPDAU	Level-3-260C-168 HR	-40 to 85	TM4C129 ENCPDTI3
TM4C129ENCPDTI3.B	Active	Production	TQFP (PDT) 128	90 JEDEC TRAY (5+1)	Yes	NIPDAU	Level-3-260C-168 HR	-40 to 85	TM4C129 ENCPDTI3
TM4C129ENCPDTI3G4	Active	Production	TQFP (PDT) 128	90 JEDEC TRAY (5+1)	Yes	NIPDAU	Level-3-260C-168 HR	-40 to 105	TM4C129 ENCPDTI3
TM4C129ENCPDTI3G4.B	Active	Production	TQFP (PDT) 128	90 JEDEC TRAY (5+1)	Yes	NIPDAU	Level-3-260C-168 HR	-40 to 105	TM4C129 ENCPDTI3
TM4C129ENCPDTI3R	Active	Production	TQFP (PDT) 128	1000 LARGE T&R	Yes	NIPDAU	Level-3-260C-168 HR	-40 to 85	TM4C129 ENCPDTI3
TM4C129ENCPDTI3R.B	Active	Production	TQFP (PDT) 128	1000 LARGE T&R	Yes	NIPDAU	Level-3-260C-168 HR	-40 to 85	TM4C129 ENCPDTI3
TM4C129ENCPDTT3	Active	Production	TQFP (PDT) 128	90 JEDEC TRAY (5+1)	Yes	NIPDAU	Level-3-260C-168 HR	-40 to 105	TM4C129 ENCPDTT3
TM4C129ENCPDTT3.B	Active	Production	TQFP (PDT) 128	90 JEDEC TRAY (5+1)	Yes	NIPDAU	Level-3-260C-168 HR	-40 to 105	TM4C129 ENCPDTT3
TM4C129ENCPDTT3R	Active	Production	TQFP (PDT) 128	1000 LARGE T&R	Yes	NIPDAU	Level-3-260C-168 HR	-40 to 105	TM4C129 ENCPDTT3
TM4C129ENCPDTT3R.B	Active	Production	TQFP (PDT) 128	1000 LARGE T&R	Yes	NIPDAU	Level-3-260C-168 HR	-40 to 105	TM4C129 ENCPDTT3

(1) **Status:** For more details on status, see our [product life cycle](#).

(2) **Material type:** When designated, preproduction parts are prototypes/experimental devices, and are not yet approved or released for full production. Testing and final process, including without limitation quality assurance, reliability performance testing, and/or process qualification, may not yet be complete, and this item is subject to further changes or possible discontinuation. If available for ordering, purchases will be subject to an additional waiver at checkout, and are intended for early internal evaluation purposes only. These items are sold without warranties of any kind.

(3) **RoHS values:** Yes, No, RoHS Exempt. See the [TI RoHS Statement](#) for additional information and value definition.

(4) **Lead finish/Ball material:** Parts may have multiple material finish options. Finish options are separated by a vertical ruled line. Lead finish/Ball material values may wrap to two lines if the finish value exceeds the maximum column width.

(5) **MSL rating/Peak reflow:** The moisture sensitivity level ratings and peak solder (reflow) temperatures. In the event that a part has multiple moisture sensitivity ratings, only the lowest level per JEDEC standards is shown. Refer to the shipping label for the actual reflow temperature that will be used to mount the part to the printed circuit board.

(6) **Part marking:** There may be an additional marking, which relates to the logo, the lot trace code information, or the environmental category of the part.

Multiple part markings will be inside parentheses. Only one part marking contained in parentheses and separated by a "~" will appear on a part. If a line is indented then it is a continuation of the previous line and the two combined represent the entire part marking for that device.

Important Information and Disclaimer:The information provided on this page represents TI's knowledge and belief as of the date that it is provided. TI bases its knowledge and belief on information provided by third parties, and makes no representation or warranty as to the accuracy of such information. Efforts are underway to better integrate information from third parties. TI has taken and continues to take reasonable steps to provide representative and accurate information but may not have conducted destructive testing or chemical analysis on incoming materials and chemicals. TI and TI suppliers consider certain information to be proprietary, and thus CAS numbers and other limited information may not be available for release.

In no event shall TI's liability arising out of such information exceed the total purchase price of the TI part(s) at issue in this document sold by TI to Customer on an annual basis.

TAPE AND REEL INFORMATION

QUADRANT ASSIGNMENTS FOR PIN 1 ORIENTATION IN TAPE

*All dimensions are nominal

Device	Package Type	Package Drawing	Pins	SPQ	Reel Diameter (mm)	Reel Width W1 (mm)	A0 (mm)	B0 (mm)	K0 (mm)	P1 (mm)	W (mm)	Pin1 Quadrant
TM4C129ENCPDTI3R	TQFP	PDT	128	1000	330.0	24.4	17.0	17.0	1.5	20.0	24.0	Q2

TAPE AND REEL BOX DIMENSIONS

*All dimensions are nominal

Device	Package Type	Package Drawing	Pins	SPQ	Length (mm)	Width (mm)	Height (mm)
TM4C129ENC PDTI3R	TQFP	PDT	128	1000	367.0	367.0	55.0

TRAY

Chamfer on Tray corner indicates Pin 1 orientation of packed units.

*All dimensions are nominal

Device	Package Name	Package Type	Pins	SPQ	Unit array matrix	Max temperature (°C)	L (mm)	W (mm)	K0 (µm)	P1 (mm)	CL (mm)	CW (mm)
TM4C129ENCPDTI3	PDT	TQFP	128	90	6 X 15	150	315	135.9	7620	15.4	20.3	21
TM4C129ENCPDTI3.B	PDT	TQFP	128	90	6 X 15	150	315	135.9	7620	15.4	20.3	21
TM4C129ENCPDTI3G4	PDT	TQFP	128	90	6 X 15	150	315	135.9	7620	15.4	20.3	21
TM4C129ENCPDTI3G4.B	PDT	TQFP	128	90	6 X 15	150	315	135.9	7620	15.4	20.3	21
TM4C129ENCPDTT3	PDT	TQFP	128	90	6 X 15	150	315	135.9	7620	15.4	20.3	21
TM4C129ENCPDTT3.B	PDT	TQFP	128	90	6 X 15	150	315	135.9	7620	15.4	20.3	21

IMPORTANT NOTICE AND DISCLAIMER

TI PROVIDES TECHNICAL AND RELIABILITY DATA (INCLUDING DATA SHEETS), DESIGN RESOURCES (INCLUDING REFERENCE DESIGNS), APPLICATION OR OTHER DESIGN ADVICE, WEB TOOLS, SAFETY INFORMATION, AND OTHER RESOURCES "AS IS" AND WITH ALL FAULTS, AND DISCLAIMS ALL WARRANTIES, EXPRESS AND IMPLIED, INCLUDING WITHOUT LIMITATION ANY IMPLIED WARRANTIES OF MERCHANTABILITY, FITNESS FOR A PARTICULAR PURPOSE OR NON-INFRINGEMENT OF THIRD PARTY INTELLECTUAL PROPERTY RIGHTS.

These resources are intended for skilled developers designing with TI products. You are solely responsible for (1) selecting the appropriate TI products for your application, (2) designing, validating and testing your application, and (3) ensuring your application meets applicable standards, and any other safety, security, regulatory or other requirements.

These resources are subject to change without notice. TI grants you permission to use these resources only for development of an application that uses the TI products described in the resource. Other reproduction and display of these resources is prohibited. No license is granted to any other TI intellectual property right or to any third party intellectual property right. TI disclaims responsibility for, and you will fully indemnify TI and its representatives against, any claims, damages, costs, losses, and liabilities arising out of your use of these resources.

TI's products are provided subject to [TI's Terms of Sale](#) or other applicable terms available either on [ti.com](https://www.ti.com) or provided in conjunction with such TI products. TI's provision of these resources does not expand or otherwise alter TI's applicable warranties or warranty disclaimers for TI products.

TI objects to and rejects any additional or different terms you may have proposed.

Mailing Address: Texas Instruments, Post Office Box 655303, Dallas, Texas 75265

Copyright © 2025, Texas Instruments Incorporated