

TLV61040-Q1 Automotive Low-Power DC-DC Boost Converter in SOT-23 Package

1 Features

- AEC-Q100 qualified
 - Device temperature grade 1: -40°C to $+125^{\circ}\text{C}$ ambient operating temperature range
- **Functional Safety-Capable**
 - [Documentation available to aid functional safety system design](#)
- 1.8V to 20V Input voltage range
- Up to 28V adjustable output voltage range
- 400mA internal switch current limit
- Up to 2MHz switching frequency
- 25 μA typical no load quiescent current
- 0.4 μA typical shutdown current
- Internal soft start
- Space-saving, 5-pin SOT-23 package

2 Applications

- [Automotive telematics, ecall, and tolling](#)
- [Infotainment and clusters](#)
- [Advanced driver assistance system \(ADAS\)](#)
- LCD bias supplies
- White-LED supplies for LCD backlights
- Dual-CELL NiMH/NiCd or single-CELL li-ion battery-powered systems
- Standard 3.3V or 5V to 12V conversions

3 Description

The TLV61040-Q1 devices are high-frequency boost converters for automotive applications. The devices are designed for generating output voltages up to 28V from a pre-regulated low voltage rail, dual-cell NiMH/NiCd, or a single-cell Li-Ion battery, supporting input voltages from 1.8V to 20V.

The TLV61040-Q1 devices operate with a switching frequency up to 2MHz, allowing the use of small external components such as ceramic as well as tantalum output capacitors. Combined with the space-saving, 5-pin SOT-23 package, the TLV61040-Q1 devices accomplish a small overall design size. The TLV61040-Q1 device has an internal 400mA switch current limit, offering lower output voltage ripple and allowing the use of a smaller form factor inductor for lower-power applications.

The TLV61040-Q1 devices operate in a pulse frequency modulation (PFM) scheme with constant peak current control. The combination of low quiescent current (25 μA typical) and the optimized control scheme enable operation of the devices at high efficiency over the entire load current range.

Package Information

PART NUMBER	PACKAGE ⁽¹⁾	PACKAGE SIZE ⁽²⁾
TLV61040-Q1	DDC (SOT-23-THN, 5)	2.9mm × 2.8mm

- (1) For more information, see [Section 10](#).
- (2) The package size (length × width) is a nominal value and includes pins, where applicable.

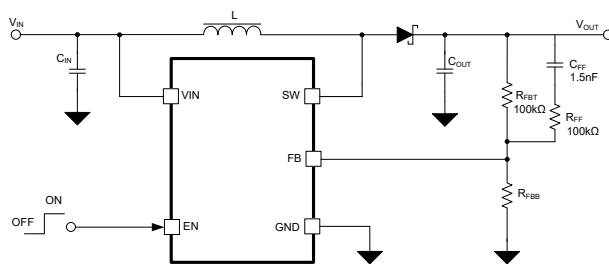

Typical Application Diagram

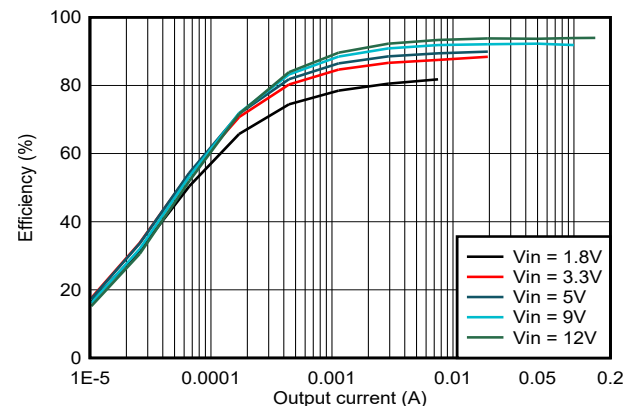

Efficiency vs Output Current, $V_{OUT} = 18\text{V}$



Table of Contents

1 Features	1	7 Application and Implementation	9
2 Applications	1	7.1 Application Information.....	9
3 Description	1	7.2 Typical Application.....	9
4 Pin Configuration and Functions	3	7.3 Power Supply Recommendations.....	14
5 Specifications	4	7.4 Layout.....	15
5.1 Absolute Maximum Ratings.....	4	8 Device and Documentation Support	16
5.2 ESD Ratings.....	4	8.1 Device Support.....	16
5.3 Recommended Operating Conditions.....	4	8.2 Receiving Notification of Documentation Updates...	16
5.4 Thermal Information.....	4	8.3 Support Resources.....	16
5.5 Electrical Characteristics.....	5	8.4 Trademarks.....	16
5.6 Typical Characteristics.....	6	8.5 Electrostatic Discharge Caution.....	16
6 Detailed Description	7	8.6 Glossary.....	16
6.1 Overview.....	7	9 Revision History	16
6.2 Functional Block Diagram.....	7	10 Mechanical, Packaging, and Orderable	
6.3 Feature Description.....	7	Information	16
6.4 Device Functional Modes.....	8		

4 Pin Configuration and Functions

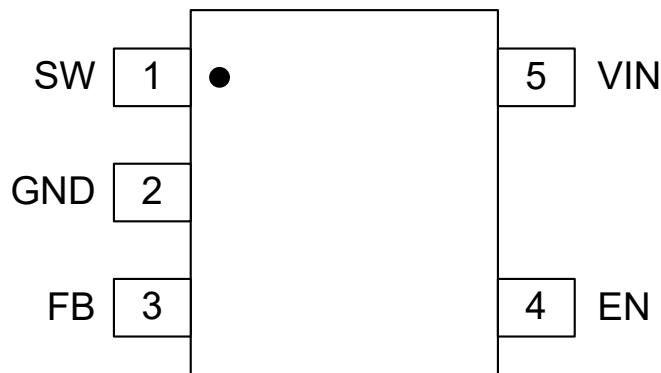

Figure 4-1. DDC Package 5 Pin SOT-23-THN (Top View)

Table 4-1. Pin Functions

PIN		TYPE ⁽¹⁾	DESCRIPTION
NAME	NO.		
EN	4	I	This pin is the enable pin of the device. Pulling this pin to ground forces the device into shutdown mode reducing the supply current to less than 1 μ A. This pin must not be left floating and must be terminated.
FB	3	I	This pin is the feedback pin of the device. Connect this pin to the external voltage divider to program the desired output voltage.
GND	2	—	Ground
SW	1	I	Connect the inductor and the Schottky diode to this pin. This pin is the switch pin and is connected to the drain of the internal power MOSFET.
V _{IN}	5	I	Supply voltage pin

(1) I = input, O = output

5 Specifications

5.1 Absolute Maximum Ratings

over operating free-air temperature range (unless otherwise noted) ⁽¹⁾

		MIN	MAX	UNIT
Voltage range at terminals ⁽²⁾	VIN,EN	-0.3	20.5	V
	SW	-0.3	32	V
	FB	-0.3	6	V
Operating junction temperature range, T _J		-40	150	°C
Storage temperature, T _{stg}		-65	150	°C

- (1) Operation outside the *Absolute Maximum Ratings* may cause permanent device damage. *Absolute Maximum Ratings* do not imply functional operation of the device at these or any other conditions beyond those listed under *Recommended Operating Conditions*. If used outside the *Recommended Operating Conditions* but within the *Absolute Maximum Ratings*, the device may not be fully functional, and this may affect device reliability, functionality, performance, and shorten the device lifetime.
- (2) All voltage values are with respect to network ground terminal.

5.2 ESD Ratings

			VALUE	UNIT
V _(ESD)	Electrostatic discharge	Human body model (HBM), per AEC Q100-002, all pins ⁽¹⁾	±2000	V
		Charged device model (CDM), per AEC Q100-011, all pins	±750	V

- (1) AEC Q100-002 indicates that HBM stressing must be in accordance with the ANSI/ESDA/JEDEC JS-001 specification.

5.3 Recommended Operating Conditions

over operating free-air temperature range (unless otherwise noted)

		MIN	TYP	MAX	UNIT
V _{IN}	Input voltage range	1.8		20	V
V _{OUT}	Output voltage range	4.5		28	V
L	Inductance range	2.2	10	22	μH
C _{IN}	Effective input capacitance range	1	10		μF
C _{OUT}	Effective output capacitance range	1	10	120	μF
T _J	Operating junction temperature	-40		125	°C

5.4 Thermal Information

THERMAL METRIC ⁽¹⁾		TLV61040-Q1	UNIT
		DDC (SOT23)	
		5 PINS	
R _{θJA}	Junction-to-ambient thermal resistance	145.8	°C/W
R _{θJC(top)}	Junction-to-case (top) thermal resistance	77.6	
R _{θJB}	Junction-to-board thermal resistance	56.5	
ψ _{JT}	Junction-to-top characterization parameter	28.5	
ψ _{JB}	Junction-to-board characterization parameter	54.9	
R _{θJC(bot)}	Junction-to-case (bottom) thermal resistance	NA	

- (1) For more information about traditional and new thermal metrics, see the [Semiconductor and IC Package Thermal Metrics](#) application note.

5.5 Electrical Characteristics

$T_J = -40^{\circ}\text{C}$ to 150°C , $V_{IN} = 5.0\text{V}$. Typical values are at $T_J = 25^{\circ}\text{C}$, unless otherwise noted.

PARAMETER		TEST CONDITIONS	MIN	TYP	MAX	UNIT
POWER SUPPLY						
V_{IN}	Input voltage range		1.8		20	V
V_{IN_UVLO}	Undervoltage lockout threshold	V_{IN_UVLO} rising		1.7	1.79	V
		V_{IN_UVLO} falling		1.55	1.64	
V_{IN_HYS}	V_{IN_UVLO} hysteresis			150		mV
I_{Q_VIN}	Quiescent current into VIN pin	IC enabled, no load, no switching, $V_{IN} = 2.6\text{V}$ to 20V , $FB = 1.4\text{V}$, $T_J = -40^{\circ}\text{C}$ to 125°C		25	50	μA
I_{SD}	Shutdown current into VIN pin	IC disabled, $V_{IN} = 2.6\text{V}$ to 20V , $T_J = -40^{\circ}\text{C}$ to 125°C		0.4	2.1	μA
I_{FB_LKG}	Leakage current into FB pin	$T_J = -40^{\circ}\text{C}$ to 125°C			50	nA
I_{SW_LKG}	Leakage current into SW pin	IC disabled, $SW = 28\text{V}$, $T_J = -40^{\circ}\text{C}$ to 125°C			500	nA
OUTPUT						
V_{OUT}	Output voltage range		4.5		28	V
V_{REF}	Reference Voltage at FB pin	$T_J = -40^{\circ}\text{C}$ to 125°C	1.209	1.233	1.258	V
POWER SWITCH						
$R_{DS(on)}$	Low-side MOSFET on resistance	$V_{IN} = 5\text{V}$, $V_{OUT} = 12\text{V}$		200		m Ω
t_{OFF_min}	Minimum off time			400	500	ns
t_{ON_min}	Minimum on time			45	150	ns
I_{LIM_SW}	TLV61040-Q1 Peak switch current limit	$V_{IN} = 5\text{V}$	320	400	480	mA
D_{min}	Minimum duty cycle	$V_{OUT} = 4.5\text{V}$ to 28V		13.5%	16.5%	
$t_{STARTUP}$	Soft startup time	Internal SS ramp time, from 0V to V_{REF}		2.5		ms
LOGIC INTERFACE						
V_{EN_H}	EN Logic high threshold				1.2	V
V_{EN_L}	EN Logic low threshold		0.4			V
R_{EN}	EN pulldown resistor			1		M Ω
PROTECTION						
T_{SD}	Thermal shutdown threshold	T_J rising		170		$^{\circ}\text{C}$
T_{SD_HYS}	Thermal shutdown hysteresis	T_J falling below T_{SD}		20		$^{\circ}\text{C}$

5.6 Typical Characteristics

TLV61040-Q1, $T_A = 25^\circ\text{C}$, unless otherwise noted

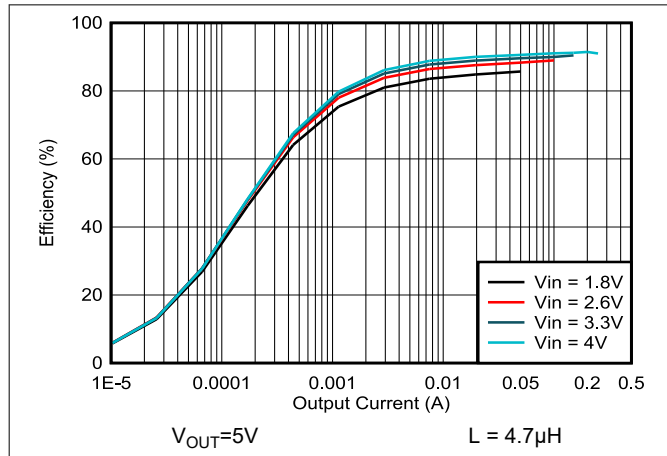

Figure 5-1. Efficiency vs Output Current

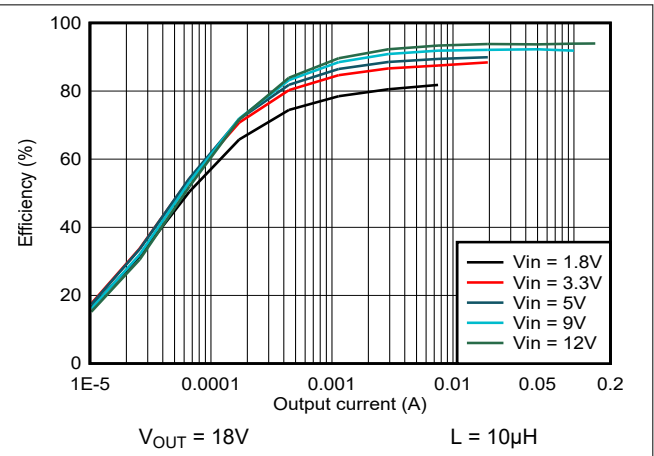

Figure 5-2. Efficiency vs Output Current

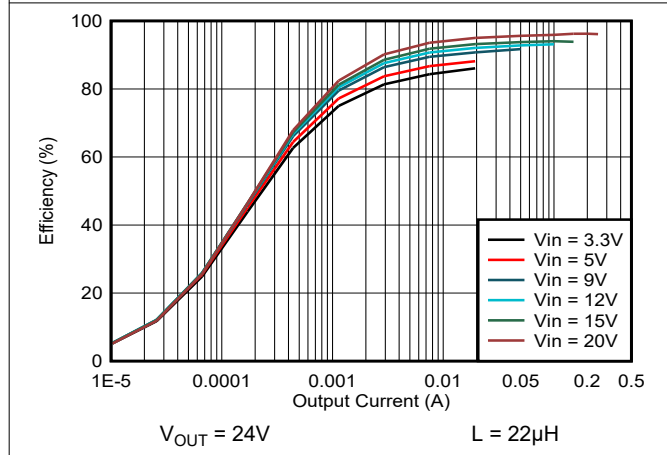

Figure 5-3. Efficiency vs Output Current

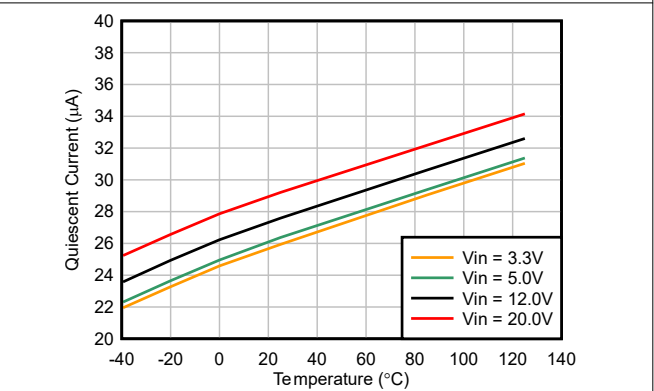

Figure 5-4. Quiescent Current vs Temperature

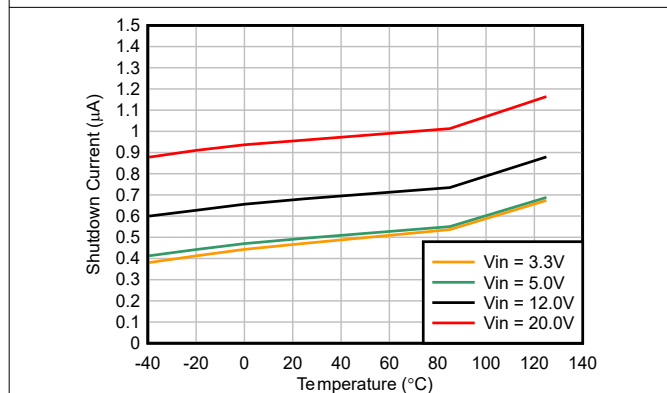

Figure 5-5. Shutdown Current vs Temperature

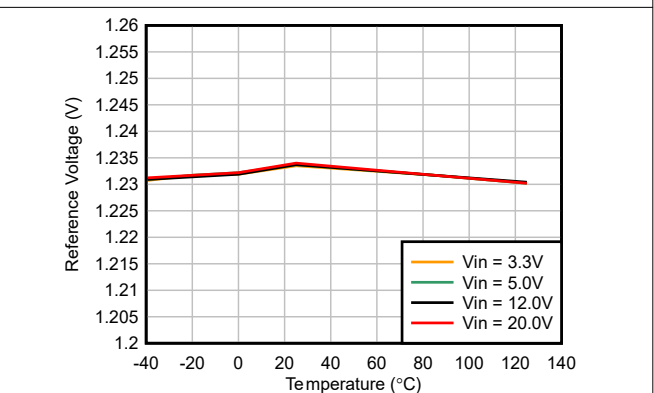

Figure 5-6. Reference Voltage vs Temperature

6 Detailed Description

6.1 Overview

The TLV61040-Q1 is a high-frequency boost converter dedicated for small-to-medium LCD bias supply and white-LED backlight supplies. The device is designed for generating output voltages up to 28V from a dual-cell NiMH/NiCd, a single-cell device Li-Ion battery, or 3.3V, 5V, 12V standard voltage bus.

6.2 Functional Block Diagram

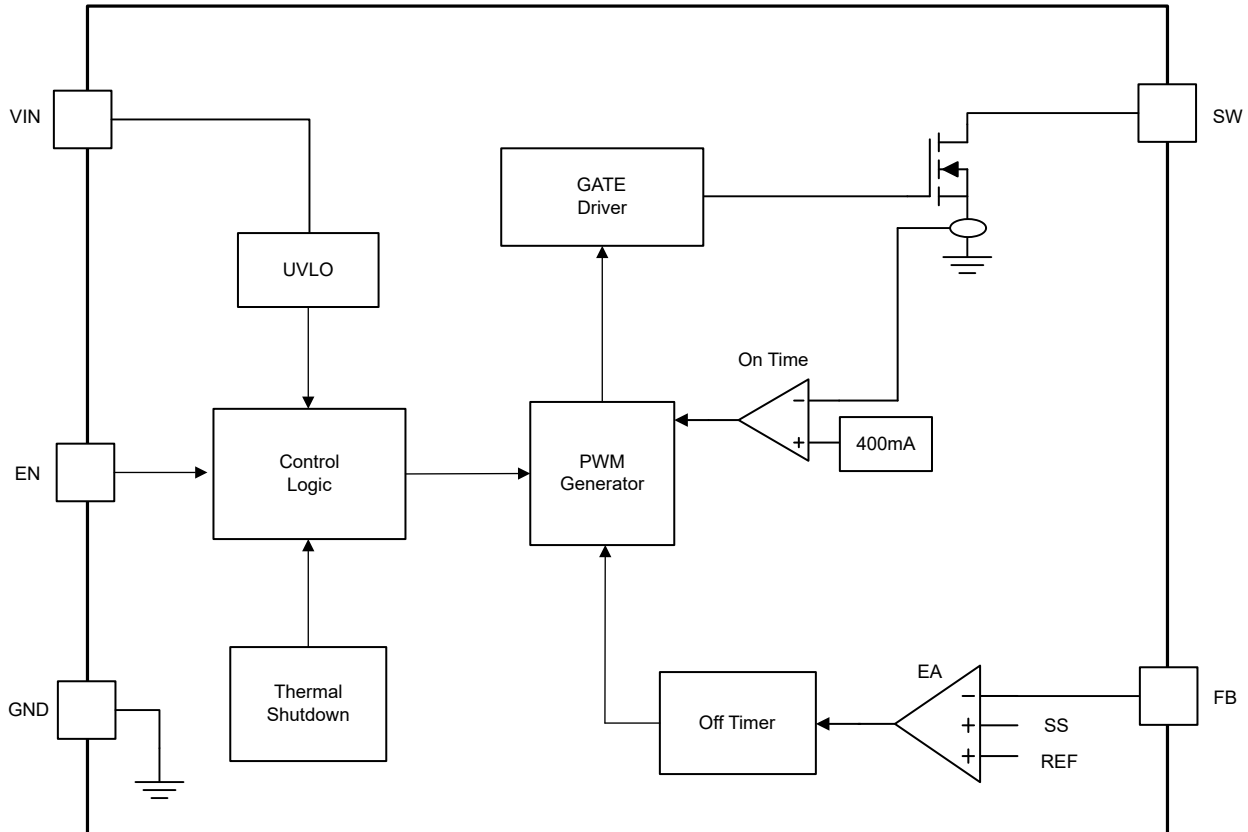

6.3 Feature Description

6.3.1 Peak Current Control

The internal switch turns on until the inductor current reaches the typical peak current limit (I_{LIM}) of 400mA. Due to the internal propagation delay of typical 60ns, the actual current exceeds the peak current limit threshold by a small amount. Use Equation 1 to calculate the typical peak current limit:

$$I_{peak(typ)} = I_{LIM} + \frac{V_{IN}}{L} \times 60ns \quad (1)$$

where

- V_{IN} = Input voltage
- L = Selected inductor value
- I_{LIM} = Typical peak current limit, 400mA

The higher the input voltage and the lower the inductor value, the greater the peak.

By selecting the TLV61040-Q1, tailoring the design to the specific application current limit requirements is possible. A lower current limit supports applications requiring lower output power and allows the use of an

inductor with a lower current rating and a smaller form factor. A lower current limit typically has a lower output-voltage ripple as well.

6.3.2 Soft Start

The soft-start feature helps the regulator to gradually reach the steady state operating point, therefore reducing start-up stresses and surge. When the input voltage is applied, the output capacitor is charged to V_{IN} through the inductor and high side rectifier diode. After reaching the 1.7V (typical) UVLO rising threshold and EN logic high, the internal soft-start control circuit initiates to ramp the reference voltage with slew rate from 0V to 1.233V within 2.5ms (typical).

All inductive step-up converters exhibit high inrush current during start-up if no special precaution is made. This action can cause voltage drops at the input rail during start-up and can result in an unwanted or early system shutdown. The TLV61040-Q1 limits this inrush current by increasing the current limit in two steps starting from $I_{LIM} / 4$ for 256 cycles to $I_{LIM} / 2$ for the next 256 cycles, and then full current limit (see [Figure 7-2](#)).

6.3.3 Enable

Pulling the enable (EN) to ground shuts down the device, reducing the shutdown current to 0.4 μ A (typical). Because there is a conductive path from the input to the output through the inductor and Schottky diode, the output voltage is equal to the input voltage during shutdown. The enable pin must be terminated and must not be left floating.

6.3.4 Undervoltage Lockout

An undervoltage lockout prevents misoperation of the device at input voltages below typical 1.55V. When the input voltage is below the undervoltage threshold, the main switch is turned off.

6.3.5 Thermal Shutdown

An internal thermal shutdown is implemented and turns off the internal MOSFETs when the typical junction temperature of 170°C is exceeded. The thermal shutdown has a hysteresis of typically 20°C. This data is based on statistical means and is not tested during the regular mass production of the IC.

6.4 Device Functional Modes

The TLV61040-Q1 operates with an wide input voltage range of 1.8V to 20V and can generate output voltages up to 28V. The device operates in a pulse frequency modulation (PFM) scheme with constant peak current control. This control scheme maintains high efficiency over the entire load current range, and with a switching frequency up to 2MHz, the device enables the use of very small external components.

The converter monitors the output voltage, and the feedback voltage is connected to error amplifier with reference voltage of typically 1.233V. The output of error amplifier controls the off-time timer. After the timer ends, the internal switch turns on and the current ramps up. The switch turns off as soon as the inductor current reaches the internally set peak current of typically 400mA. See also [Section 6.3.1](#). The second criteria that turns off the switch is the maximum ON-time of 6 μ s (typical). This action is to limit the maximum ON-time of the converter to cover for extreme conditions. As the switch is turned off, the external Schottky diode is forward biased, delivering the current to the output. The switch remains off for a minimum of 400ns (typical), or until the off timer is down. Using this PFM peak-current control scheme, the switching frequency of the converter depends on the output current, which results in high efficiency over the entire load current range.

7 Application and Implementation

Note

Information in the following applications sections is not part of the TI component specification, and TI does not warrant its accuracy or completeness. TI's customers are responsible for determining suitability of components for their purposes, as well as validating and testing their design implementation to confirm system functionality.

7.1 Application Information

The TLV61040-Q1 is designed for output voltages up to 28V with an input voltage range of 1.8V to 20V. The TLV61040-Q1 can operate up to 400mA typical peak load current. The device operates in a pulse-frequency-modulation (PFM) scheme with constant peak-current control. This control scheme maintains high efficiency over the entire load current range, and with a switching frequency up to 2MHz, the device enables the use of very small external components.

7.2 Typical Application

The following section provides a step-by-step design approach for configuring the TLV61040-Q1 as a voltage-regulating boost converter for LCD bias supply, as shown in [Figure 7-1](#).

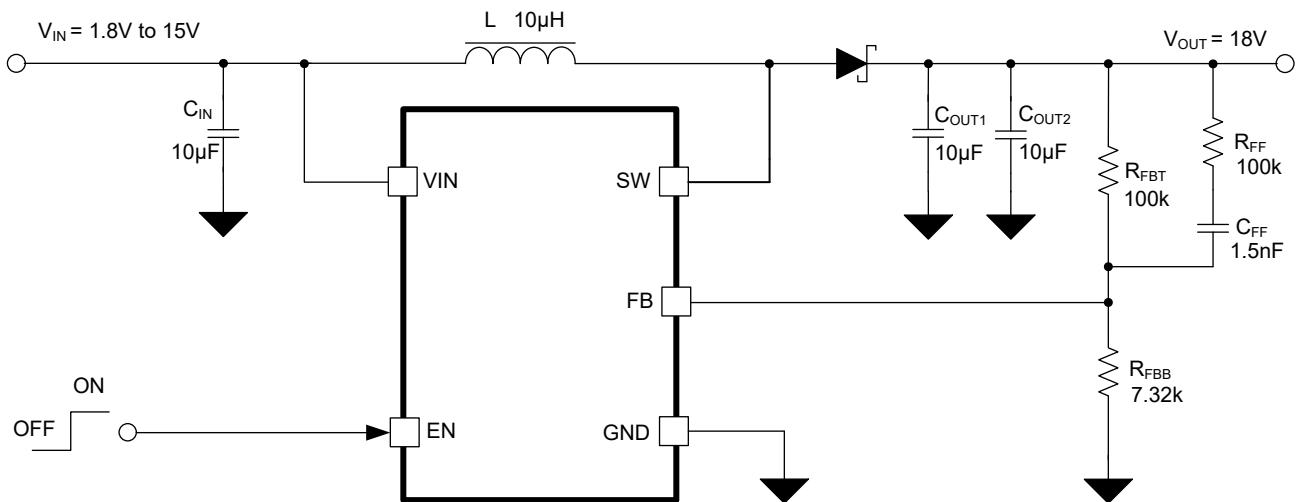

Figure 7-1. LCD Bias Supply

7.2.1 Design Requirements

Table 7-1 lists the design parameters for this example.

Table 7-1. Design Parameters

DESIGN PARAMETER	EXAMPLE VALUE
Input voltage	1.8V to 6V or 9V to 15V
Output voltage	18V
Output current	10mA ($V_{IN} = 1.8V$ to 6V) 50mA ($V_{IN} = 9V$ to 15V)

7.2.2 Detailed Design Procedure

7.2.2.1 Inductor Selection, Maximum Load Current

Because the PFM peak-current control scheme is inherently stable, the inductor value does not affect the stability of the regulator. Depending on the application, TI recommends inductor values from 2.2µH to 47µH. And the final inductor value must be selected by the following instructions.

There are two conditions that limit the maximum inductor value. The maximum inductor value is firstly determined by the maximum on-time of the switch, typically 6µs. The peak current limit of 400mA (typically) must be reached within this 6µs period for proper operation. Use [Equation 2](#) to calculate the maximum inductor value.

$$L_{max1} = V_{IN(min)} \times \frac{6\mu s}{I_{LIM}} \quad (2)$$

Where:

- $V_{IN(min)}$ = minimum input voltage
- $I_{LIM} = 400mA$

The other limitation of maximum inductor value is inductor current ripple cannot be lower than 100mA. The minimum inductor current ripple occurs when load is heavy to trigger minimum off time of 400ns (typically). Use [Equation 3](#) to calculate the maximum inductor value.

$$L_{max2} = (V_{OUT} - V_{IN(max)}) \times \frac{400ns}{100mA} \quad (3)$$

Where:

- $V_{IN(max)}$ = maximum input voltage
- V_{OUT} = target output voltage

The inductor value need to be lower than both L_{max1} and L_{max2} .

There is also a minimum limitation of the inductor value that the current limit must not be triggered during minimum on-time. Use [Equation 4](#) to calculate the minimum inductor value.

$$L_{min} = V_{IN(max)} \times \frac{150ns}{I_{LIM}} \quad (4)$$

The inductor value can be selected within the limitation. Besides, the inductor value also affects the maximum available load current. The larger the inductor value, the larger the maximum available load current. After selecting the inductor value, maximum available load current must be checked. If the actual load current is higher than maximum available load current, the V_{OUT} drops. Use [Equation 5](#) to calculate the maximum available load current.

$$I_{Load(max)} = \begin{cases} \frac{\eta L I_{LIM}^2}{2 \left(\frac{L I_{LIM}}{V_{IN(min)}} + 400ns \right) (V_{OUT} - V_{IN(min)})}, & \text{if } \frac{V_{OUT} - V_{IN(min)}}{L \div 400ns} > I_{LIM} \\ \frac{\eta V_{IN(min)}}{V_{OUT}} \left(I_{LIM} - \frac{V_{OUT} - V_{IN(min)}}{2L} \times 400ns \right), & \text{if } \frac{V_{OUT} - V_{IN(min)}}{L \div 400ns} \leq I_{LIM} \end{cases} \quad (5)$$

Where:

- $V_{IN(min)}$ = minimum input voltage
- V_{OUT} = target output voltage
- $I_{LIM} = 400mA$
- L = selected inductor value
- η = expected converter efficiency. Typically 80% to 95% at maximum available load current

A smaller inductor value gives a higher converter switching frequency, but lowers the efficiency and the maximum available inductor current.

The next step is to calculate the switching frequency at the nominal load current using [Equation 6](#):

$$f_{sw}(I_{Load}) = \frac{2 \times I_{Load}(V_{OUT} - V_{IN})}{\eta L I_{peak}^2} \quad (6)$$

Where:

- I_{peak} = peak current as described in the [Peak Current Control](#) section
- L = selected inductor value
- I_{Load} = nominal load current

Lastly, the selected inductor must have a saturation current that exceeds the maximum peak current of the converter (as calculated in the [Peak Current Control](#) section). Use the maximum value for I_{LIM} for this calculation.

Another important inductor parameter is the DC resistance. The lower the DC resistance, the higher the efficiency of the converter. [Table 7-2](#) lists a few typical inductors for LCD bias supply design (see [Figure 7-1](#)), but customers must verify and validate the typical inductors to check whether the typical inductors are designed for the customer's application.

Table 7-2. Typical Inductors for LCD Bias Supply

PART NUMBER	L(μH)	DCR MAX (mΩ)	SATURATION CURRENT TYPICAL (A)	VENDOR ⁽¹⁾
XFL3012-223ME	22	630	0.52	Coilcraft
XFL3012-103ME	10	306	0.74	Coilcraft
XFL3012-472ME	4.7	171	1.2	Coilcraft

(1) See the [Third-Party Products Disclaimer](#).

7.2.2.2 Setting The Output Voltage

The output voltage is calculated as:

$$V_{OUT} = 1.233 V \times \left(1 + \frac{R_{FBT}}{R_{FBB}}\right) \quad (7)$$

For automotive applications, TO does not recommend a resistor over 100kΩ. To minimize leakage current from feedback network, TI recommends R_{FBT} as 100kΩ so R_{FBB} can be variable to adjust V_{OUT} .

In TLV61040-Q1, the inductor current is limited to 400mA, so during start-up, the output voltage cannot rise fast enough to follow internal reference. Then the internal error amplifier output goes high and even gets saturated. So after V_{OUT} reaches the target, the error amplifier needs time to exit saturation and enter normal regulation. During this time, the V_{OUT} continue rising, causing overshoot. A feedforward capacitor of 1.5nF and a feedforward resistor of 100kΩ across the upper feedback resistor R_{FBT} is required to prevent the overshoot. Without a feedforward resistor, whose value is too small, the TLV61040-Q1 shows *double pulses* or a pulse burst instead of single pulses at the switch node (SW), causing higher output voltage ripple.

7.2.2.3 Input and Output Capacitor Selection

The output capacitor is mainly selected to meet the requirements for output ripple and loop stability. This ripple voltage is related to the capacitor capacitance and the equivalent series resistance (ESR). Assuming a ceramic capacitor with zero ESR, use [Equation 8](#) to calculate the minimum capacitance needed for a given ripple.

$$C_{OUT} = \frac{I_{Load} D_{max}}{f_{sw} V_{ripple}} \quad (8)$$

Where:

- I_{Load} = Nominal load current
- D_{max} = Maximum duty cycle in the application
- f_{sw} = Switching frequency at the nominal load current as calculated previously
- V_{ripple} = Target peak to peak output voltage ripple

The ESR impact on the output ripple must be considered if tantalum or aluminum electrolytic capacitors are used.

Take care when evaluating the derating of a ceramic capacitor under DC bias, aging, and AC signal. For example, the DC bias can significantly reduce capacitance. A ceramic capacitor can lose more than 50% of the capacitance at the rated voltage. Therefore, always leave margin on the voltage rating to make sure of adequate capacitance at the required output voltage.

TI recommends using the output capacitor with effective capacitance 10 μ F, which covers the major applications. TI also recommends placing a small 1 μ F capacitor right across the rectifier diode cathode to the GND pin of the TLV61040-Q1 to reduce the high RMS current loop inductance. The output capacitor affects the small signal control loop stability of the boost regulator. If the output capacitor is below the range, the boost regulator can potentially become unstable. Increasing the output capacitor makes the output voltage ripple smaller in PWM mode.

But if total output capacitance is too large, because the boost converter cannot control inductor current when V_{IN} is close to V_{OUT} , the inductor current increases to a high level during start-up until V_{OUT} is high enough. The larger the C_{OUT} and V_{IN} , the higher the peak inrush current. If the peak inductor current is higher than 2.5A, the device has risk to damage. TI recommends total output capacitance for TLV61040-Q1 to be less than 120 μ F.

Table 7-3 lists the recommended capacitor for the TLV61040-Q1.

Table 7-3. Recommended Output Capacitors for the TLV61040-Q1

PART NUMBER	C_{OUT} (μ F)	RATING	PACKAGE	VENDOR ⁽¹⁾
TMK316BLD106KL	10	25V, X5R	1206	Taiyo Yuden
CC1206KKX5R8BB106	10	25V, X5R	1206	Yageo
CGA5L1X7R1H106K160AC	10	50V, X7R	1206	TDK

(1) See the [Third-Party Products Disclaimer](#).

The ceramic capacitors are an excellent choice for the input decoupling of the step-up converter because the ceramic capacitors have extremely low ESR and are available in small footprints. Input capacitors must be located as close as possible to the device. While a 10 μ F input capacitor or equivalent is sufficient for the most applications, larger values can be used to reduce input current ripple.

Take care when using only ceramic input capacitors. When a ceramic capacitor is used at the input and the power is being supplied through long wires, such as from a wall adapter, a load step at the output can induce ringing at the V_{IN} pin. This ringing can couple to the output and be mistaken as loop instability or can even damage the device. Additional "bulk" capacitor (electrolytic or tantalum) in this circumstance, must be placed between C_{IN} and the power source lead to reduce ringing that can occur between the inductance of the power source leads and C_{IN} .

7.2.2.4 Diode Selection

A Schottky diode is the preferred type due to the low forward voltage drop and small reverse recovery charge. Low reverse leakage current is important parameter when selecting the Schottky diode. The diode must be rated to handle the maximum output voltage plus any switching node ringing. Also, the diode must be able to handle the average output current.

7.2.3 Application Curves

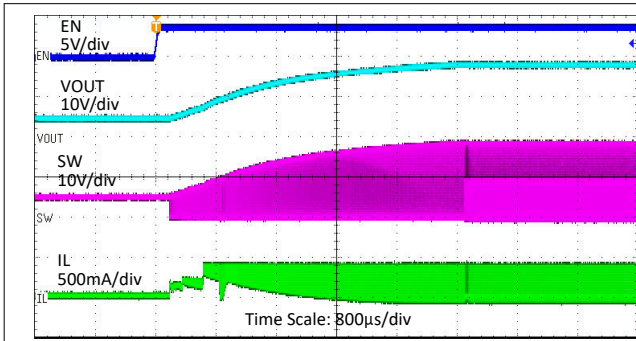

Figure 7-2. Start-up by EN Waveforms

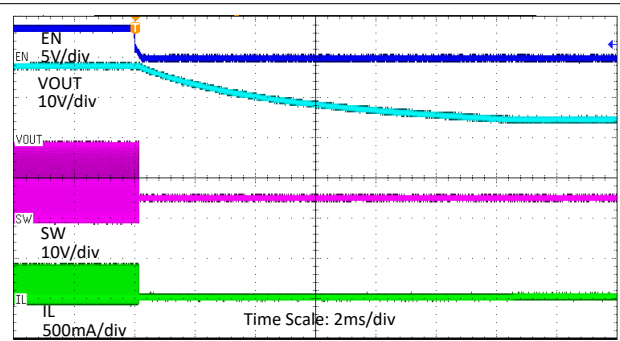

Figure 7-3. Shutdown by EN waveforms

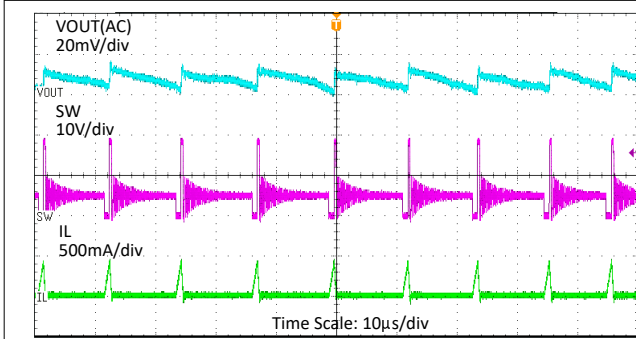

Figure 7-4. Switching Waveforms in Steady State

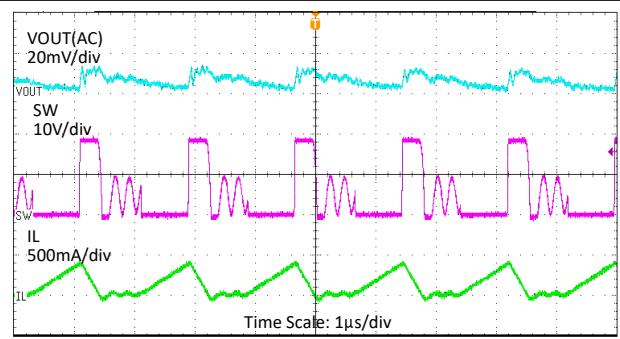

Figure 7-5. Switching Waveforms in Steady State

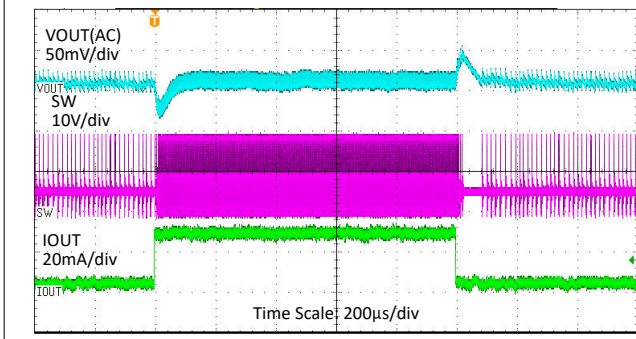

Figure 7-6. Load Transient

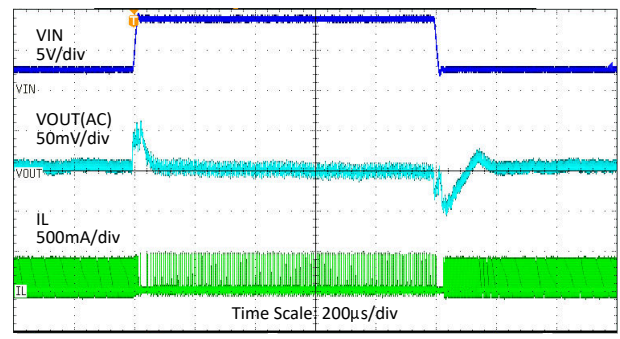

Figure 7-7. Line Transient

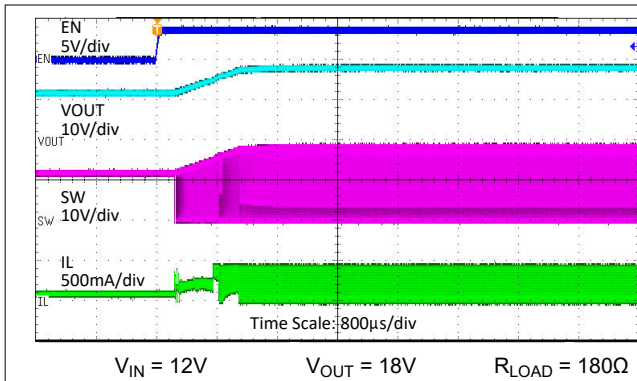

Figure 7-8. Start-up by EN waveforms

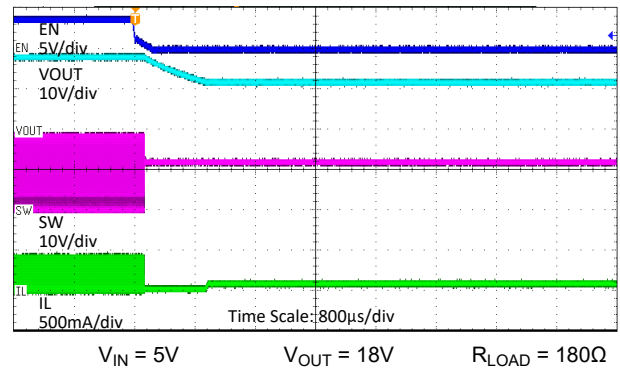

Figure 7-9. Shutdown by EN waveforms

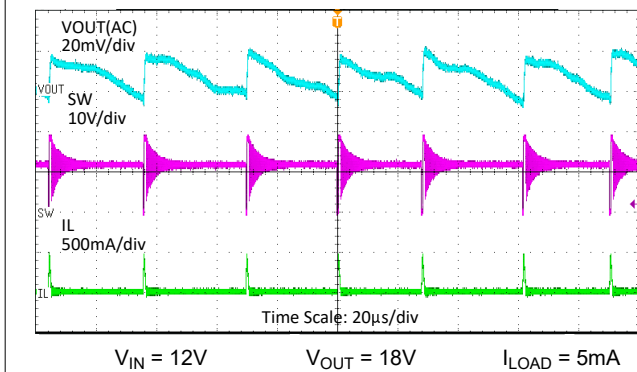

Figure 7-10. Switching Waveforms in Steady State

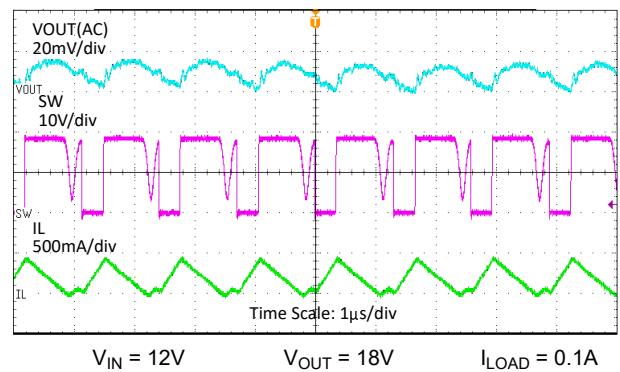

Figure 7-11. Switching Waveforms in Steady State

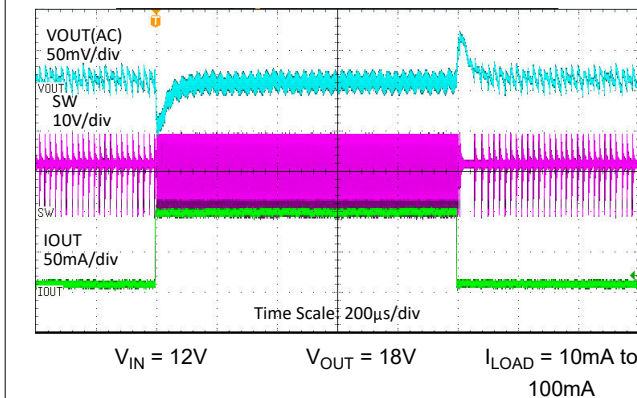

Figure 7-12. Load Transient

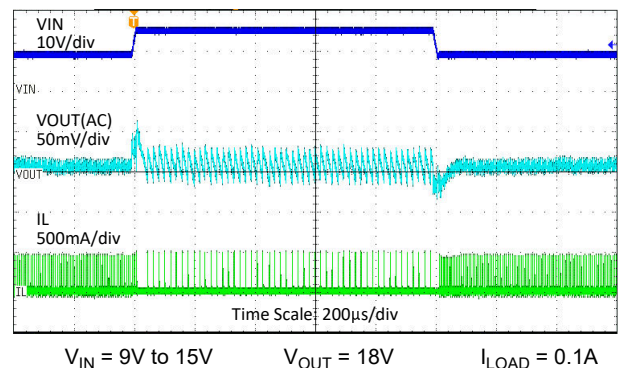

Figure 7-13. Line Transient

7.3 Power Supply Recommendations

The device is designed to operate from an input voltage supply range from 1.8V to 20V. The output current of the input power supply must be rated according to the supply voltage, output voltage, and output current of TLV61040-Q1.

7.4 Layout

7.4.1 Layout Guidelines

Typical for all switching power supplies, the layout is an important step in the design, especially at high peak currents and switching frequencies. If the layout is not carefully done, the regulator can show noise problems and duty cycle jitter.

Figure 7-14 provides an example of layout design with TLV61040-Q1.

- Place the input capacitor as close as possible to the input pin for good input voltage filtering.
- Place the inductor and diode as close as possible to the switch pin to minimize the noise coupling into other circuits.
- Keeping the switching pin and plane area short helps in minimizing the radiated emissions. Make sure to have a very low impedance switch plane to reduce the switching losses, and therefore a trade-off must be made between these two and the switching pin and plane must be optimized.
- Because the feedback pin and network is noise-sensitive, route the feedback network away from the inductor.
- Shield the feedback pin and feedback network with a ground plane or trace to minimize noise coupling into this circuit.
- A star ground connection or ground plane minimizes ground shifts and noise.

7.4.2 Layout Example

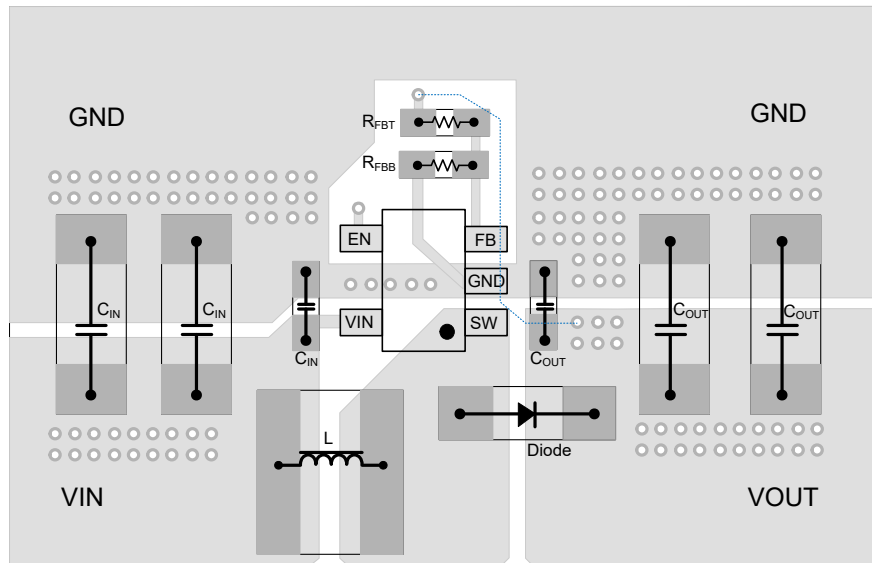

Figure 7-14. Layout Diagram

8 Device and Documentation Support

8.1 Device Support

8.1.1 Third-Party Products Disclaimer

TI'S PUBLICATION OF INFORMATION REGARDING THIRD-PARTY PRODUCTS OR SERVICES DOES NOT CONSTITUTE AN ENDORSEMENT REGARDING THE SUITABILITY OF SUCH PRODUCTS OR SERVICES OR A WARRANTY, REPRESENTATION OR ENDORSEMENT OF SUCH PRODUCTS OR SERVICES, EITHER ALONE OR IN COMBINATION WITH ANY TI PRODUCT OR SERVICE.

8.2 Receiving Notification of Documentation Updates

To receive notification of documentation updates, navigate to the device product folder on ti.com. Click on *Notifications* to register and receive a weekly digest of any product information that has changed. For change details, review the revision history included in any revised document.

8.3 Support Resources

[TI E2E™ support forums](#) are an engineer's go-to source for fast, verified answers and design help — straight from the experts. Search existing answers or ask your own question to get the quick design help you need.

Linked content is provided "AS IS" by the respective contributors. They do not constitute TI specifications and do not necessarily reflect TI's views; see TI's [Terms of Use](#).

8.4 Trademarks

TI E2E™ is a trademark of Texas Instruments.
All trademarks are the property of their respective owners.

8.5 Electrostatic Discharge Caution



This integrated circuit can be damaged by ESD. Texas Instruments recommends that all integrated circuits be handled with appropriate precautions. Failure to observe proper handling and installation procedures can cause damage.

ESD damage can range from subtle performance degradation to complete device failure. Precision integrated circuits may be more susceptible to damage because very small parametric changes could cause the device not to meet its published specifications.

8.6 Glossary

[TI Glossary](#) This glossary lists and explains terms, acronyms, and definitions.

9 Revision History

DATE	REVISION	NOTES
March 2026	*	Initial Release

10 Mechanical, Packaging, and Orderable Information

The following pages include mechanical, packaging, and orderable information. This information is the most current data available for the designated devices. This data is subject to change without notice and revision of this document. For browser-based versions of this data sheet, refer to the left-hand navigation.

PACKAGING INFORMATION

Orderable part number	Status (1)	Material type (2)	Package Pins	Package qty Carrier	RoHS (3)	Lead finish/ Ball material (4)	MSL rating/ Peak reflow (5)	Op temp (°C)	Part marking (6)
TLV61040QDDCRQ1	Active	Production	null (null)	3000 LARGE T&R	Yes	SN	Level-1-260C-UNLIM	-40 to 125	1040Q

(1) **Status:** For more details on status, see our [product life cycle](#).

(2) **Material type:** When designated, preproduction parts are prototypes/experimental devices, and are not yet approved or released for full production. Testing and final process, including without limitation quality assurance, reliability performance testing, and/or process qualification, may not yet be complete, and this item is subject to further changes or possible discontinuation. If available for ordering, purchases will be subject to an additional waiver at checkout, and are intended for early internal evaluation purposes only. These items are sold without warranties of any kind.

(3) **RoHS values:** Yes, No, RoHS Exempt. See the [TI RoHS Statement](#) for additional information and value definition.

(4) **Lead finish/Ball material:** Parts may have multiple material finish options. Finish options are separated by a vertical ruled line. Lead finish/Ball material values may wrap to two lines if the finish value exceeds the maximum column width.

(5) **MSL rating/Peak reflow:** The moisture sensitivity level ratings and peak solder (reflow) temperatures. In the event that a part has multiple moisture sensitivity ratings, only the lowest level per JEDEC standards is shown. Refer to the shipping label for the actual reflow temperature that will be used to mount the part to the printed circuit board.

(6) **Part marking:** There may be an additional marking, which relates to the logo, the lot trace code information, or the environmental category of the part.

Multiple part markings will be inside parentheses. Only one part marking contained in parentheses and separated by a "-" will appear on a part. If a line is indented then it is a continuation of the previous line and the two combined represent the entire part marking for that device.

Important Information and Disclaimer: The information provided on this page represents TI's knowledge and belief as of the date that it is provided. TI bases its knowledge and belief on information provided by third parties, and makes no representation or warranty as to the accuracy of such information. Efforts are underway to better integrate information from third parties. TI has taken and continues to take reasonable steps to provide representative and accurate information but may not have conducted destructive testing or chemical analysis on incoming materials and chemicals. TI and TI suppliers consider certain information to be proprietary, and thus CAS numbers and other limited information may not be available for release.

In no event shall TI's liability arising out of such information exceed the total purchase price of the TI part(s) at issue in this document sold by TI to Customer on an annual basis.

IMPORTANT NOTICE AND DISCLAIMER

TI PROVIDES TECHNICAL AND RELIABILITY DATA (INCLUDING DATASHEETS), DESIGN RESOURCES (INCLUDING REFERENCE DESIGNS), APPLICATION OR OTHER DESIGN ADVICE, WEB TOOLS, SAFETY INFORMATION, AND OTHER RESOURCES "AS IS" AND WITH ALL FAULTS, AND DISCLAIMS ALL WARRANTIES, EXPRESS AND IMPLIED, INCLUDING WITHOUT LIMITATION ANY IMPLIED WARRANTIES OF MERCHANTABILITY, FITNESS FOR A PARTICULAR PURPOSE OR NON-INFRINGEMENT OF THIRD PARTY INTELLECTUAL PROPERTY RIGHTS.

These resources are intended for skilled developers designing with TI products. You are solely responsible for (1) selecting the appropriate TI products for your application, (2) designing, validating and testing your application, and (3) ensuring your application meets applicable standards, and any other safety, security, regulatory or other requirements.

These resources are subject to change without notice. TI grants you permission to use these resources only for development of an application that uses the TI products described in the resource. Other reproduction and display of these resources is prohibited. No license is granted to any other TI intellectual property right or to any third party intellectual property right. TI disclaims responsibility for, and you fully indemnify TI and its representatives against any claims, damages, costs, losses, and liabilities arising out of your use of these resources.

TI's products are provided subject to [TI's Terms of Sale](#), [TI's General Quality Guidelines](#), or other applicable terms available either on ti.com or provided in conjunction with such TI products. TI's provision of these resources does not expand or otherwise alter TI's applicable warranties or warranty disclaimers for TI products. Unless TI explicitly designates a product as custom or customer-specified, TI products are standard, catalog, general purpose devices.

TI objects to and rejects any additional or different terms you may propose.

Copyright © 2026, Texas Instruments Incorporated

Last updated 10/2025