

THS4536 High-Precision, 60MHz, Fully Differential Amplifier

1 Features

- Bandwidth: 65MHz ($G = 1V/V$)
- Gain bandwidth product: 80MHz
- THS453x Device Comparison:
 - THS4535 offset voltage: 2mV (max)
 - THS4535 offset drift: $1.4\mu V/^\circ C$ (max)
 - THS4536 offset voltage: 20 μV (max)
 - THS4536 offset drift: $0.8\mu V/^\circ C$ (max)
- Supply operating range: 2.7V to 5.5V
- Low harmonic distortion:
 - HD2: 125dBc at $2V_{PP}$, 10kHz
 - HD3: 114dBc at $2V_{PP}$, 10kHz
- Slew rate: 47V/ μs & 57V/ μs (Rising & Falling)
- Low noise:
 - Voltage Noise: $4.3nV/\sqrt{Hz}$ (2.5kHz 1/f corner)
 - Current Noise: 70fA/ \sqrt{Hz}
- Low Bias & Offset Current: $\pm 40pA$ at 125C (max)
- Supply current: 4.7mA
- Negative rail input (NRI)
- Rail-to-rail output (RRO):
 - THS4535: 100mV from rails (typical)
 - THS4536: 80mV from rails (max)
- Temperature range: $-40^\circ C$ to $+125^\circ C$

2 Applications

- [16-bit to 20-bit, differential, SAR and \$\Delta\Sigma\$ drivers](#)
- [Differential active filters](#)
- Motor drives
- [Battery testers](#)
- [Power analyzers](#)

3 Description

The THS4536 is a 60MHz fully differential amplifier (FDA) that is specifically designed to drive fully differential analog-to-digital converters (ADCs) up to 2MSPS. The THS453x family offers two options: THS4535 (untrimmed) & THS4536 (trimmed).

The THS4535 is an excellent choice for simple single-to-dual conversions. FDAs such as the THS4535 offer performance benefits over traditional dual op amps, including bandwidth and phase balance between outputs and a V_{OCM} pin to easily adjust the output common-mode voltage. For higher dc precision applications, such as high-speed low-side current shunt measurements, the THS4536 provides package level trim for offset and offset drift. THS453x devices also provide higher transient current output drive to meet the needs of successive approximation register (SAR) ADC charge injection and delta-sigma ($\Delta\Sigma$) ADC precharge buffers.

Package Information

PART NUMBER ⁽¹⁾	PACKAGE ⁽²⁾	PACKAGE SIZE ⁽³⁾
THS4536	DGK (VSSOP, 8)	3mm × 4.9mm
	RUN (WQFN, 10)	2mm × 2mm

(1) See also [Section 4](#).

(2) For more information, see [Section 11](#).

(3) The package size (length × width) is a nominal value and includes pins, where applicable.

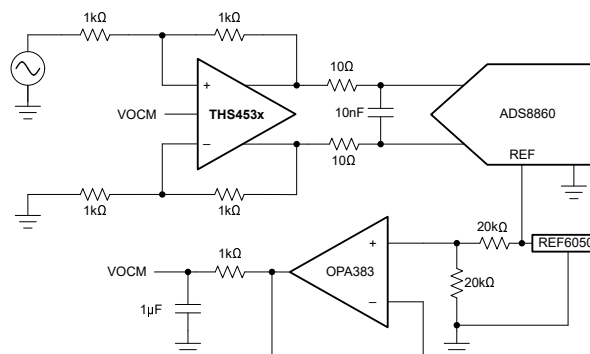

Simplified Schematic: Gain of 1V/V, Single-Ended-Input to Differential-Output Interface to SAR ADC



Table of Contents

1 Features	1	7.4 Device Functional Modes.....	19
2 Applications	1	8 Application and Implementation	20
3 Description	1	8.1 Application Information.....	20
4 Device Comparison Table	3	8.2 Typical Application.....	22
5 Pin Configuration and Functions	4	8.3 Power Supply Recommendations.....	23
6 Specifications	5	8.4 Layout.....	24
6.1 Absolute Maximum Ratings.....	5	9 Device and Documentation Support	26
6.2 ESD Ratings.....	5	9.1 Receiving Notification of Documentation Updates.....	26
6.3 Recommended Operating Conditions.....	5	9.2 Support Resources.....	26
6.4 Thermal Information.....	6	9.3 Trademarks.....	26
6.5 Electrical Characteristics.....	7	9.4 Electrostatic Discharge Caution.....	26
6.6 Typical Characteristics.....	10	9.5 Glossary.....	26
7 Detailed Description	17	10 Revision History	26
7.1 Overview.....	17	11 Mechanical, Packaging, and Orderable Information	26
7.2 Functional Block Diagram.....	17		
7.3 Feature Description.....	18		

4 Device Comparison Table

DEVICE	OFFSET VOLTAGE (MAX)	OFFSET DRIFT (MAX)
THS4535DGKR	2mV	1.4 μ V/°C
THS4536DGKR	50 μ V	0.8 μ V/°C
THS4535RUNR	2mV	1.4 μ V/°C
THS4536RUNR	50 μ V	0.8 μ V/°C

5 Pin Configuration and Functions

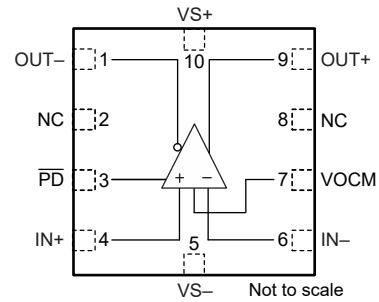
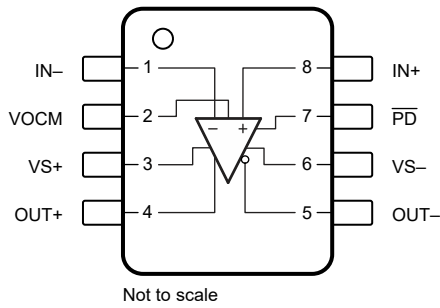

Figure 5-1. DGK Package, 8-Pin VSSOP (Top View), External Gain **Figure 5-2. RUN Package, 10-Pin WQFN (Top View), External Gain**

Pin Functions

NAME	PIN		TYPE	DESCRIPTION
	NO.			
	DGK (VSSOP)	RUN (WQFN)		
IN-	1	6	Input	Inverting (negative) amplifier input
IN+	8	4	Input	Noninverting (positive) amplifier input
NC	—	2, 8	—	Leave unconnected (external gain)
OUT-	5	1	Output	Inverting (negative) amplifier output
OUT+	4	9	Output	Noninverting (positive) amplifier output
PD	7	3	Input	Power down. $\overline{\text{PD}}$ = logic low = power off mode; PD = logic high = normal operation.
VOCM	2	7	Input	Output common-mode voltage control input
VS-	6	5	Power	Negative power-supply input
VS+	3	10	Power	Positive power-supply input

6 Specifications

6.1 Absolute Maximum Ratings

over operating free-air temperature range (unless otherwise noted)⁽¹⁾

		MIN	MAX	UNIT
V_S	Total supply voltage, $V_S = (V_{S+} - V_{S-})$		6	V
Voltage	Supply turn-on/off dV/dT ⁽²⁾		TBD	V/ μ s
	Input, output, power down and common-mode pin voltage	$(V_{S-}) - 0.5$	$(V_{S+}) + 0.5$	V
Voltage	Input pin (for Gain = 1V/V devices) ⁽⁴⁾	$(V_{S-}) - 11$	$(V_{S+}) + 11$	V
Voltage	Input pin (for Gain = 2V/V devices) ⁽⁴⁾	$(V_{S-}) - 5.75$	$(V_{S+}) + 5.75$	V
Voltage	Input pin (for fixed Gain = 0.5V/V devices) ⁽⁴⁾	$(V_{S-}) - 21.5$	$(V_{S+}) + 21.5$	V
Voltage	Differential input voltage		TBD	V
Voltage	Input pin voltage range, $(V_{S-} + \text{MIN}), (V_{S+} + \text{MAX})$	-0.5	0.5	V
Voltage	Output pin voltage range, $(V_{S-} + \text{MIN}), (V_{S+} + \text{MAX})$	-0.5	0.5	V
Voltage	Power down pin voltage range, $(V_{S-} + \text{MIN}), (V_{S+} + \text{MAX})$	-0.5	0.5	V
Voltage	Common-mode pin voltage range, $(V_{S-} + \text{MIN}), (V_{S+} + \text{MAX})$	-0.5	0.5	V
I_{IN}	Continuous input current		± 10	mA
I_{OUT}	Continuous output current ⁽³⁾		± 65	mA
T_J	Junction temperature		150	$^{\circ}$ C
T_A	Free-air temperature	-40	125	$^{\circ}$ C
T_{stg}	Storage temperature	-65	150	$^{\circ}$ C

- (1) Operation outside the *Absolute Maximum Ratings* may cause permanent device damage. *Absolute Maximum Ratings* do not imply functional operation of the device at these or any other conditions beyond those listed under *Recommended Operating Conditions*. If used outside the *Recommended Operating Conditions* but within the *Absolute Maximum Ratings*, the device may not be fully functional, and this may affect device reliability, functionality, performance, and shorten the device lifetime.
- (2) Staying below this specification ensures that the edge-triggered ESD absorption devices across the supply pins remains off.
- (3) Long-term continuous output current for electromigration limits.
- (4) Input range for fixed gain devices is calculated using ± 10 mA max current for amplifier inputs, and assuming output can go to supply, V_{S+} for positive range and V_{S-} for negative range, R_G is 2k Ω /1k Ω /0.5k Ω for gain of 0.5/1/2V/V. Range for input voltage is $(V_{S-}) - (10\text{mA} \cdot R_G - 0.5 \cdot (1+1/G))$ to $(V_{S+}) + (10\text{mA} \cdot R_G + 0.5 \cdot (1+1/G))$

6.2 ESD Ratings

			VALUE	UNIT
$V_{(ESD)}$	Electrostatic discharge	Human body model (HBM), per ANSI/ESDA/JEDEC JS-001 ⁽¹⁾	± 2500	V
		Charged device model (CDM), per ANSI/ESDA/JEDEC JS-002, all pins ⁽²⁾	± 1000	

- (1) JEDEC document JEP155 states that 500V HBM allows safe manufacturing with a standard ESD control process.
- (2) JEDEC document JEP157 states that 250V CDM allows safe manufacturing with a standard ESD control process.

6.3 Recommended Operating Conditions

over operating free-air temperature range (unless otherwise noted)

		MIN	NOM	MAX	UNIT
V_S	Total supply voltage	2.7		5.5	V
T_J	Junction temperature	-40	25	125	$^{\circ}$ C

6.4 Thermal Information

THERMAL METRIC ⁽¹⁾		THS4536		UNIT
		DGK (VSSOP)	RUN (WQFN)	
		8 PINS	10 PINS	
$R_{\theta JA}$	Junction-to-ambient thermal resistance	151.8	147.1	°C/W
$R_{\theta JC(top)}$	Junction-to-case (top) thermal resistance	46.4	86.9	°C/W
$R_{\theta JB}$	Junction-to-board thermal resistance	86.1	85.2	°C/W
Ψ_{JT}	Junction-to-top characterization parameter	1.4	8.2	°C/W
Ψ_{JB}	Junction-to-board characterization parameter	84.7	84.9	°C/W
$R_{\theta JC(bot)}$	Junction-to-case (bottom) thermal resistance	N/A	N/A	°C/W

- (1) For more information about traditional and new thermal metrics, see the [Semiconductor and IC Package Thermal Metrics](#) application report.

6.5 Electrical Characteristics

at $T_A = 25^\circ\text{C}$, $V_{S+} - V_{S-} = 5\text{V}$, $V_{\text{OCM}}^{(1)} = \text{open}$, $R_F = 1\text{k}\Omega$, differential gain (G) = 1V/V , $V_O = 2V_{\text{PP}}$, $R_L = 1\text{k}\Omega$, and $\overline{\text{PD}} = \text{logic high}$ (unless otherwise noted)

PARAMETER		TEST CONDITIONS		MIN	TYP	MAX	UNIT
AC PERFORMANCE							
SSBW	Small-signal bandwidth	$V_O = 100\text{mV}_{\text{PP}}$	$G = 1\text{V/V}$, < 1dB peaking		65		MHz
			$G = 2\text{V/V}$		42		
			$G = 5\text{V/V}$		16		
			$G = 10\text{V/V}$		9		
GBWP	Gain-bandwidth product	$V_O = 100\text{mV}_{\text{PP}}$, $G = 20\text{V/V}$			80		MHz
LSBW	Large-signal bandwidth	$V_O = 2V_{\text{PP}}$, $G = 1\text{V/V}$			17		MHz
	Bandwidth for 0.1dB flatness	$V_O = 2V_{\text{PP}}$, $G = 1\text{V/V}$			8		MHz
SR	Slew rate (20%–80%)	$V_O = 2\text{V}$ step	Rising		47		V/ μs
			Falling		57		
	Overshoot and undershoot	$V_O = 2\text{V}$ step, 8ns input rise time			5		%
t_s	Settling time	$V_O = 2\text{V}$ step	To 0.1%		100		ns
			To 0.01%		150		
	Rise and fall time (10%–90%)	$V_O = 2\text{V}$ step, 8ns input rise time			30		ns
HD2	Second-order harmonic distortion	$V_O = 2V_{\text{PP}}$	$f = 1\text{kHz}$		140		dBc
			$f = 10\text{kHz}$		125		
			$f = 1\text{MHz}$		85		
		$V_O = 8V_{\text{PP}}$	$f = 1\text{kHz}$		135		
			$f = 10\text{kHz}$		125		
			$f = 1\text{MHz}$		60		
HD3	Third-order harmonic distortion	$V_O = 2V_{\text{PP}}$	$f = 1\text{kHz}$		135		dBc
			$f = 10\text{kHz}$		114		
			$f = 1\text{MHz}$		74		
		$V_O = 8V_{\text{PP}}$	$f = 1\text{kHz}$		126		
			$f = 10\text{kHz}$		106		
			$f = 1\text{MHz}$		58		
e_n	Input differential voltage noise	$f = 100\text{kHz}$			4.3		nV/ $\sqrt{\text{Hz}}$
		1/f corner			2.4		kHz
i_n	Input current noise	$f = 100\text{kHz}$			70		fA/ $\sqrt{\text{Hz}}$
	Overdrive recovery time	$G = 2\text{V/V}$			750		ns
Z_{OUT}	Closed-loop output impedance	$f = 100\text{kHz}$ (differential)			0.3		Ω

6.5 Electrical Characteristics (continued)

at $T_A = 25^\circ\text{C}$, $V_{S+} - V_{S-} = 5\text{V}$, $V_{\text{OCM}}^{(1)} = \text{open}$, $R_F = 1\text{k}\Omega$, differential gain (G) = 1V/V , $V_O = 2V_{\text{PP}}$, $R_L = 1\text{k}\Omega$, and $\overline{\text{PD}} = \text{logic high}$ (unless otherwise noted)

PARAMETER		TEST CONDITIONS	MIN	TYP	MAX	UNIT
DC PERFORMANCE						
A_{OL}	Open-loop voltage gain	$V_O = \pm 2\text{V}$	106	126		dB
A_{OL}	Open-loop voltage gain	$V_O = \pm 2.3\text{V}$, $R_L = 40\Omega$	100	126		dB
V_{OS}	Input offset voltage			± 3	± 20	μV
	Input offset voltage drift	$T_A = -40^\circ\text{C}$ to $+125^\circ\text{C}$		± 0.3	± 0.8	$\mu\text{V}/^\circ\text{C}$
$I_{\text{B+}}, I_{\text{B-}}$	Input bias current ⁽³⁾	$T_A = 25^\circ\text{C}$		± 0.2	± 20	pA
		$T_A = -40^\circ\text{C}$ to $+125^\circ\text{C}$		± 20	± 40	
I_{OS}	Input offset current ⁽⁴⁾	$T_A = 25^\circ\text{C}$		± 0.2	± 20	pA
		$T_A = -40^\circ\text{C}$ to $+125^\circ\text{C}$		± 0.2	± 30	
INPUT						
V_{ICML}	Common-mode voltage input low	$T_A = 25^\circ\text{C}$		$V_{\text{S-}} - 0.3$	$V_{\text{S-}} - 0.2$	V
		$T_A = -40^\circ\text{C}$ to $+125^\circ\text{C}$		$V_{\text{S-}} - 0.2$	$V_{\text{S-}} - 0.1$	
V_{ICMH}	Common-mode voltage input high	$T_A = 25^\circ\text{C}$	$V_{\text{S+}} - 1.4$	$V_{\text{S+}} - 1.3$		V
		$T_A = -40^\circ\text{C}$ to $+125^\circ\text{C}$	$V_{\text{S+}} - 1.5$	$V_{\text{S+}} - 1.4$		
CMRR	Common-mode rejection ratio	$(V_{\text{S-}}) < V_{\text{CM}} < (V_{\text{S+}} - 1.5\text{V})$, $T_A = 25^\circ\text{C}$	100	114		dB
	Differential input impedance			$15 \parallel 3.4$		$\text{T}\Omega \parallel \text{pF}$
	Common mode input impedance			$30 \parallel 1.2$		$\text{T}\Omega \parallel \text{pF}$
OUTPUT						
	Output voltage low	$T_A = 25^\circ\text{C}$		$V_{\text{S-}} + 0.06$	$V_{\text{S-}} + 0.08$	V
		$T_A = -40^\circ\text{C}$ to $+125^\circ\text{C}$		$V_{\text{S-}} + 0.06$	$V_{\text{S-}} + 0.08$	
	Output voltage high	$T_A = 25^\circ\text{C}$	$V_{\text{S+}} - 0.08$	$V_{\text{S+}} - 0.06$		V
		$T_A = -40^\circ\text{C}$ to $+125^\circ\text{C}$	$V_{\text{S+}} - 0.08$	$V_{\text{S+}} - 0.06$		
	Continuous output current (slam)	$V_O = \pm 2.5\text{V}$, $R_L = 40\Omega$		± 90		mA
		$V_O = \pm 2.5\text{V}$, $R_L = 40\Omega$, $T_A = -40^\circ\text{C}$ to $+125^\circ\text{C}$		± 80		
	Linear output current	$V_O = \pm 2.3\text{V}$, $R_L = 40\Omega$, $A_{\text{OL}} > 100\text{dB}$		± 50	± 60	mA
		$T_A = 25^\circ\text{C}$		± 60		
		$T_A = -40^\circ\text{C}$ to $+125^\circ\text{C}$		± 60		
OUTPUT COMMON-MODE VOLTAGE (VOCM) CONTROL						
	$V_{\text{OCM}}^{(1)}$ small-signal bandwidth	$V_{\text{VOCM}} = 100\text{mV}_{\text{PP}}$		43		MHz
	V_{OCM} large-signal bandwidth	$V_{\text{VOCM}} = 1\text{V}_{\text{PP}}$		16		MHz
	V_{OCM} slew rate ⁽²⁾ (20%–80%)	$V_{\text{VOCM}} = 1\text{V}$ step		28		$\text{V}/\mu\text{s}$
	V_{OCM} voltage noise	$f = 100\text{kHz}$	$V_{\text{VOCM}} = \text{midsupply}$ (driven)	18		$\text{nV}/\sqrt{\text{Hz}}$
			$V_{\text{OCM}} = \text{open}$	36		
	DC output balance	$V_{\text{VOCM}} = \text{midsupply}$ (driven), $V_O = \pm 1\text{V}$		80		dB
	AC output balance	$V_{\text{VOCM}} = \text{midsupply}$ (driven), V_{OCM}/V_O (–3dB from dc)		50000		Hz
	Gain error	$(V_{\text{S-}} + 0.45) < V_{\text{VOCM}} < (V_{\text{S+}} - 1.2\text{V})$	0.997	1	1.003	V/V
	VOCM input bias current		–5	0.3	5	μA
	PSRR to V_{OCM}			82		dB
	VOCM input impedance			$250 \parallel 2.8$		$\text{k}\Omega \parallel \text{pF}$
	V_{OCM} offset voltage	VOCM pin floating	–10		10	mV
	V_{OCM} offset voltage	$V_{\text{VOCM}} = \text{midsupply}$ (driven)	–5	0.25	5	mV
	V_{OCM} offset voltage drift	VOCM pin floating, $T_A = -40^\circ\text{C}$ to $+125^\circ\text{C}$	–10	2	10	$\mu\text{V}/^\circ\text{C}$

6.5 Electrical Characteristics (continued)

at $T_A = 25^\circ\text{C}$, $V_{S+} - V_{S-} = 5\text{V}$, V_{OCM} ⁽¹⁾ = open, $R_F = 1\text{k}\Omega$, differential gain (G) = 1V/V , $V_O = 2V_{\text{PP}}$, $R_L = 1\text{k}\Omega$, and $\overline{\text{PD}}$ = logic high (unless otherwise noted)

PARAMETER		TEST CONDITIONS	MIN	TYP	MAX	UNIT
	V_{OCM} offset voltage drift	$V_{\text{VOCM}} = \text{midsupply (driven)}$, $T_A = -40^\circ\text{C}$ to $+125^\circ\text{C}$	-10	3	10	$\mu\text{V}/^\circ\text{C}$
	V_{OCM} voltage low	$< \pm 11\text{mV}$ shift from midsupply offset, $T_A = 25^\circ\text{C}$		$V_{S-} + 0.3$	$V_{S-} + 0.45$	V
		$< \pm 11\text{mV}$ shift from midsupply offset, $T_A = -40^\circ\text{C}$ to $+125^\circ\text{C}$			$V_{S-} + 0.5$	
	V_{OCM} voltage high	$T_A = 25^\circ\text{C}$, $< \pm 11\text{mV}$ shift from midsupply offset	$V_{S+} - 1.2$	$V_{S+} - 1$		V
		$T_A = -40^\circ\text{C}$ to $+125^\circ\text{C}$, $< \pm 11\text{mV}$ shift from midsupply offset	$V_{S+} - 1.3$			
POWER SUPPLY						
I_Q	Quiescent current	$V_S = 5\text{V}$, $\overline{\text{PD}}$ = logic high (active)	$T_A = 25^\circ\text{C}$	4.7	5.4	mA
			$T_A = -40^\circ\text{C}$ to $+125^\circ\text{C}$	4.7	5.4	
I_Q	Quiescent current	$V_S = 5\text{V}$, $\overline{\text{PD}}$ = logic low (shutdown)	$T_A = -40^\circ\text{C}$ to $+125^\circ\text{C}$	20		μA
PSRR	Power-supply rejection ratio	Either supply to input V_{OS}	90	110		dB
POWER DOWN						
	Enable voltage threshold	$\overline{\text{PD}}$ = logic high (active)	$V_{S+} - 0.5$			V
	Disable voltage threshold	$\overline{\text{PD}}$ = logic low (shutdown)			$V_{S-} + 0.5$	V
	Enable pin bias current	$\overline{\text{PD}}$ = high		0	6	μA
		$\overline{\text{PD}}$ = low	-15	-10		
	Turn-on time delay	Time from $\overline{\text{PD}}$ = high to $V_O = 90\%$ of final value		5		us
	Turn-off time delay	Time from $\overline{\text{PD}}$ = low to $V_O = 10\%$ of original value		40		ns

- (1) V_{VOCM} refers to the voltage at V_{OCM} pin. $V_{\text{OCM}} = [(V_{\text{OUT}+} + V_{\text{OUT}-}) / 2]$ refers to the average output voltage.
- (2) Average of the rising and falling slew rate.
- (3) Current out of the node is considered positive.
- (4) $I_{\text{OS}} = I_{\text{B}+} - I_{\text{B}-}$.

6.6 Typical Characteristics

at $T_A = 25^\circ\text{C}$, $V_{S+} - V_{S-} = 5\text{V}$, V_{OCM} = open (midsupply), $R_F = 1\text{k}\Omega$, $G = 1\text{V/V}$, $V_O = 2\text{V}_{\text{PP}}$, $R_L = 1\text{k}\Omega$, and $\overline{\text{PD}}$ = logic high (unless otherwise noted)

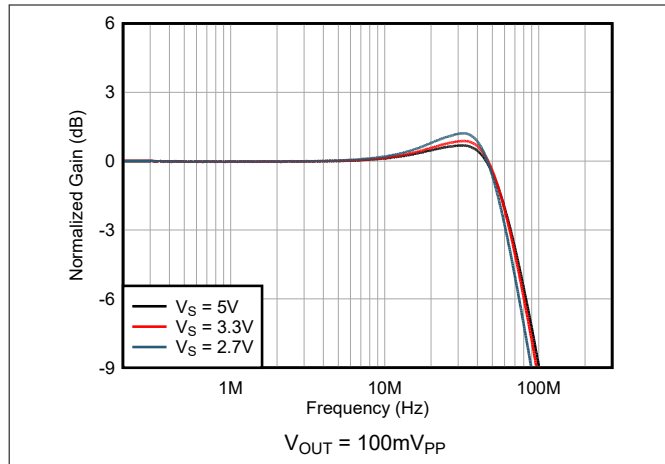

Figure 6-1. Small-Signal Bandwidth vs Supply Voltage

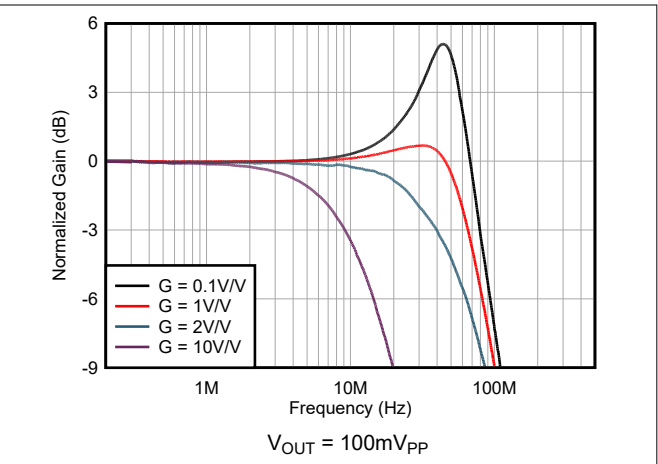

Figure 6-2. Small-Signal Bandwidth vs Gain

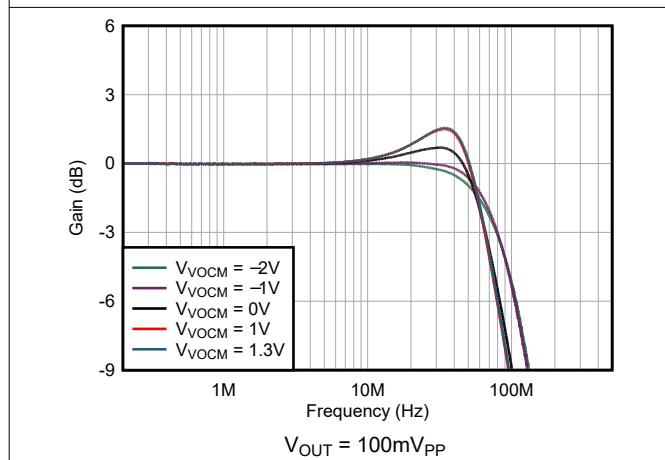

Figure 6-3. Small-Signal Bandwidth vs Output Common-Mode

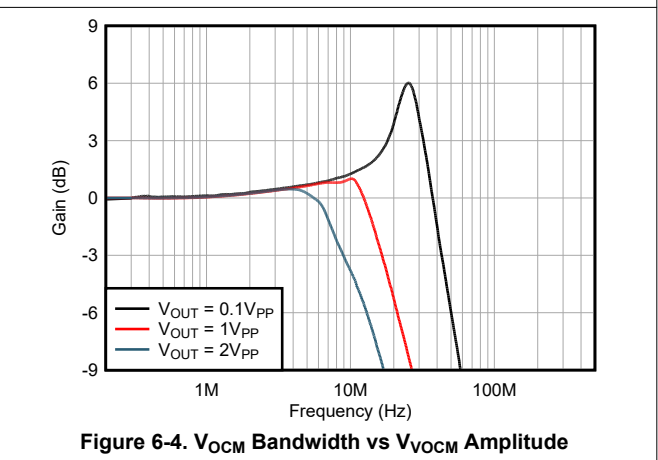

Figure 6-4. V_{OCM} Bandwidth vs V_{OCM} Amplitude

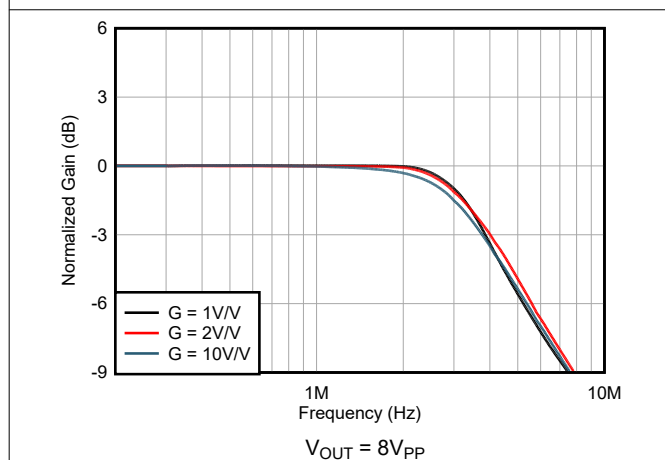

Figure 6-5. Large-Signal Bandwidth vs Gain

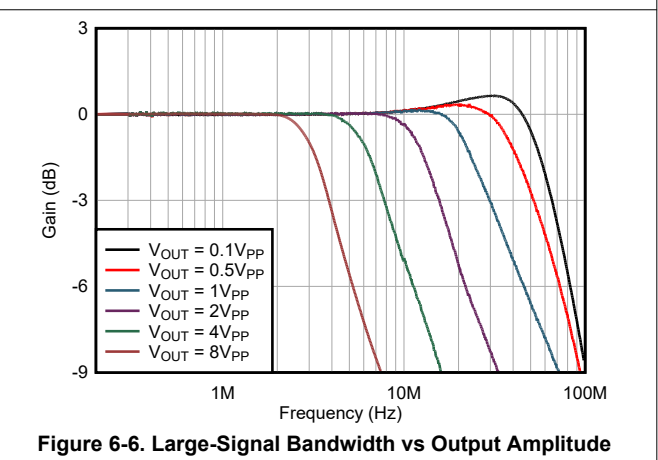

Figure 6-6. Large-Signal Bandwidth vs Output Amplitude

6.6 Typical Characteristics (continued)

at $T_A = 25^\circ\text{C}$, $V_{S+} - V_{S-} = 5\text{V}$, $V_{OCM} = \text{open (midsupply)}$, $R_F = 1\text{k}\Omega$, $G = 1\text{V/V}$, $V_O = 2V_{PP}$, $R_L = 1\text{k}\Omega$, and $\overline{\text{PD}} = \text{logic high}$ (unless otherwise noted)

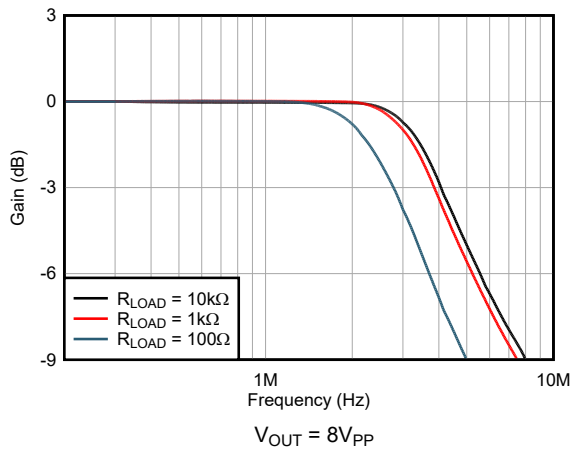

Figure 6-7. Large-Signal Bandwidth vs Load Resistance

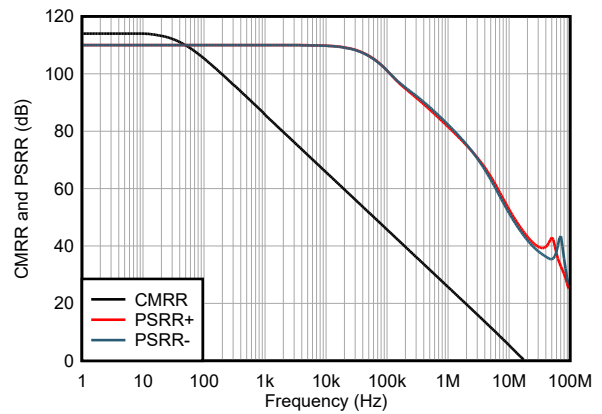

Figure 6-8. Common-Mode and Power Supply Rejection vs Frequency

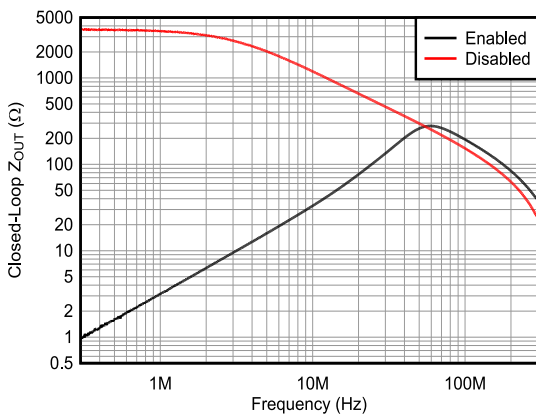

Figure 6-9. Closed Loop Output Impedance vs Frequency

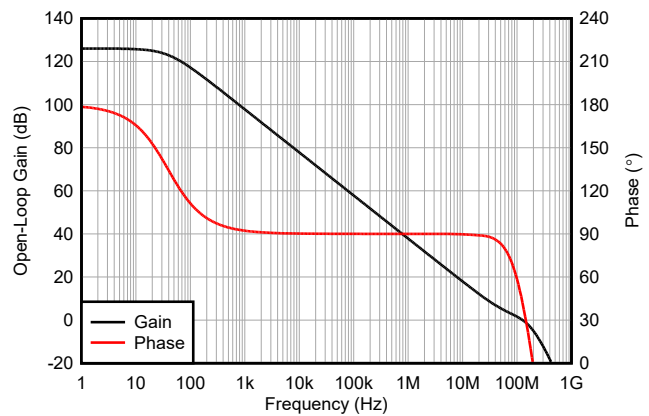

Figure 6-10. Open Loop Gain & Phase vs Frequency

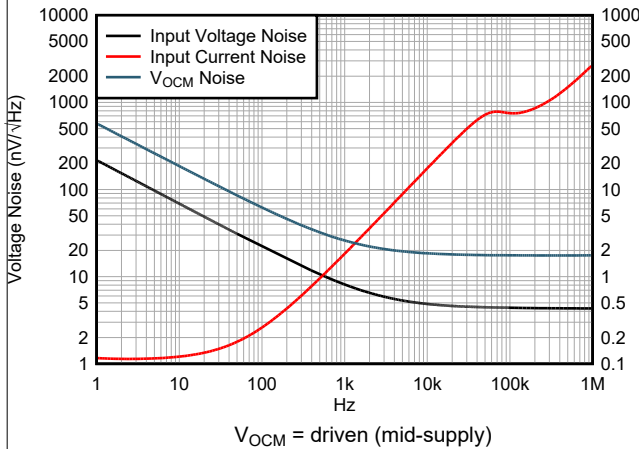

Figure 6-11. Voltage Noise vs Frequency

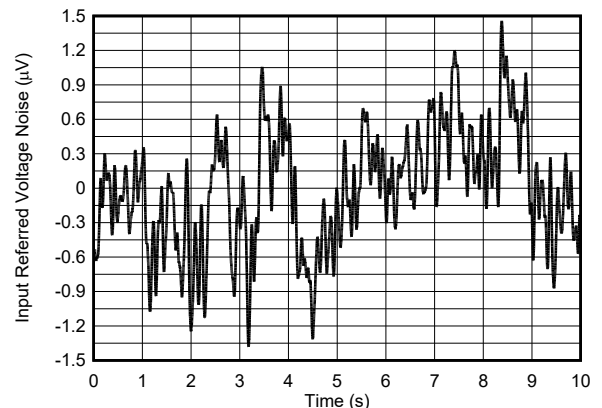

Figure 6-12. 0.1Hz to 10Hz Voltage Noise

6.6 Typical Characteristics (continued)

at $T_A = 25^\circ\text{C}$, $V_{S+} - V_{S-} = 5\text{V}$, $V_{OCM} = \text{open (midsupply)}$, $R_F = 1\text{k}\Omega$, $G = 1\text{V/V}$, $V_O = 2V_{PP}$, $R_L = 1\text{k}\Omega$, and $\overline{\text{PD}} = \text{logic high}$ (unless otherwise noted)

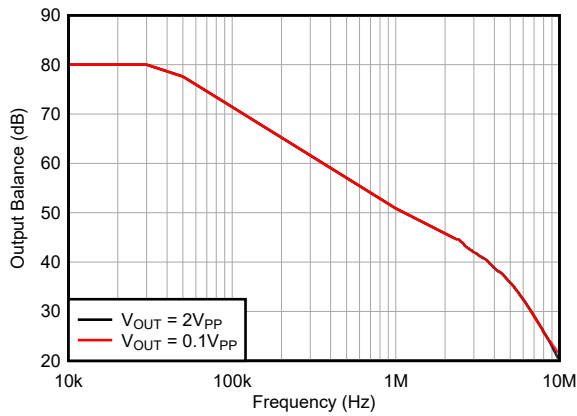

Figure 6-13. Output Balance vs Frequency

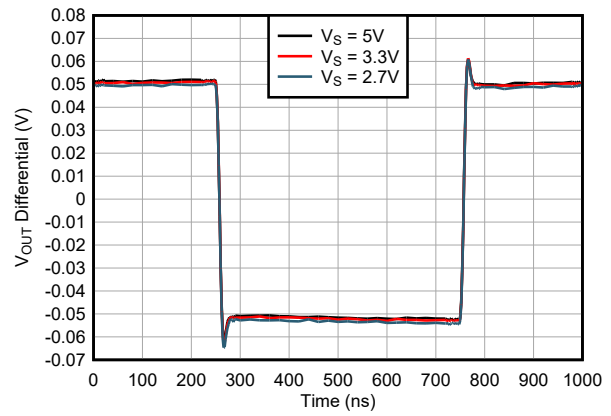

Figure 6-14. Small-Signal Step Response vs Supply Voltage

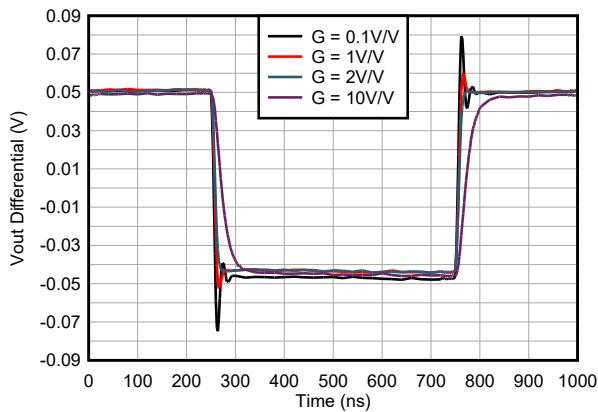

Figure 6-15. Small-Signal Step Response vs Gain

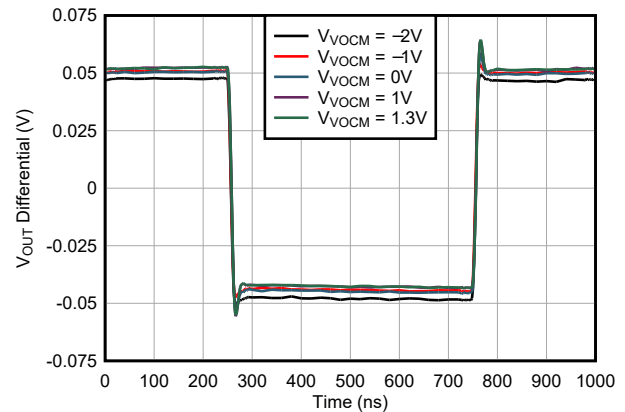

Figure 6-16. Small-Signal Step Response vs Output Common-Mode

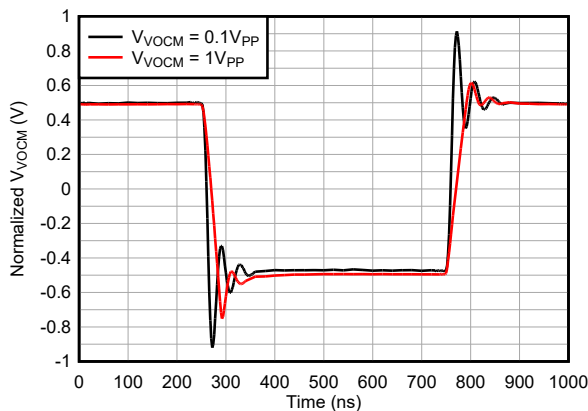

Figure 6-17. Output Common-Mode Step Response

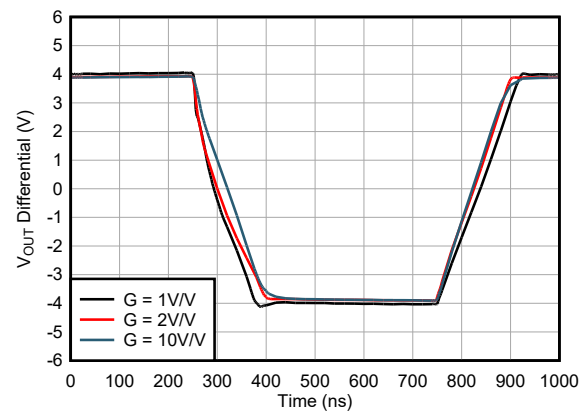

Figure 6-18. Large-Signal Step Response vs Gain

6.6 Typical Characteristics (continued)

at $T_A = 25^\circ\text{C}$, $V_{S+} - V_{S-} = 5\text{V}$, $V_{OCM} = \text{open (midsupply)}$, $R_F = 1\text{k}\Omega$, $G = 1\text{V/V}$, $V_O = 2V_{PP}$, $R_L = 1\text{k}\Omega$, and $\overline{\text{PD}} = \text{logic high}$ (unless otherwise noted)

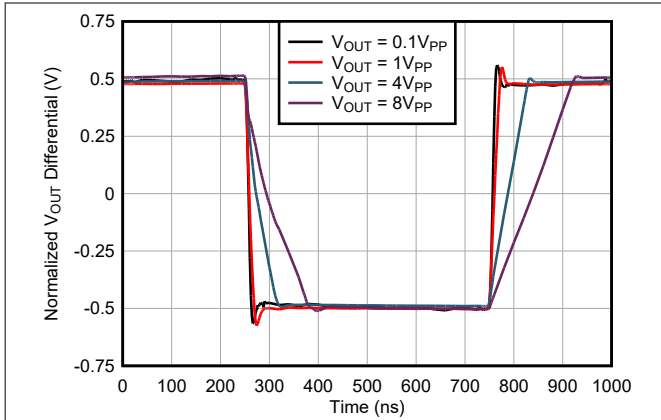

Figure 6-19. Large-Signal Step Response vs Output Amplitude

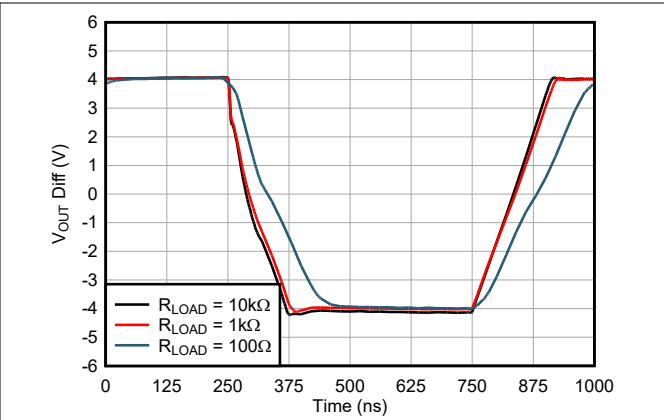

Figure 6-20. Large Signal Step Response vs Resistive Load

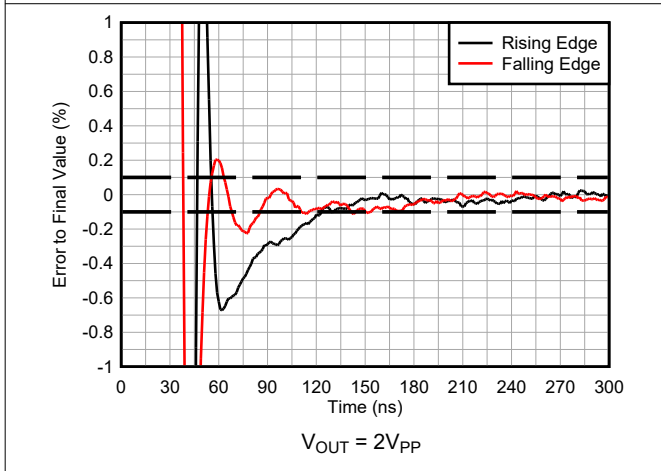

Figure 6-21. Large Signal Settling Time

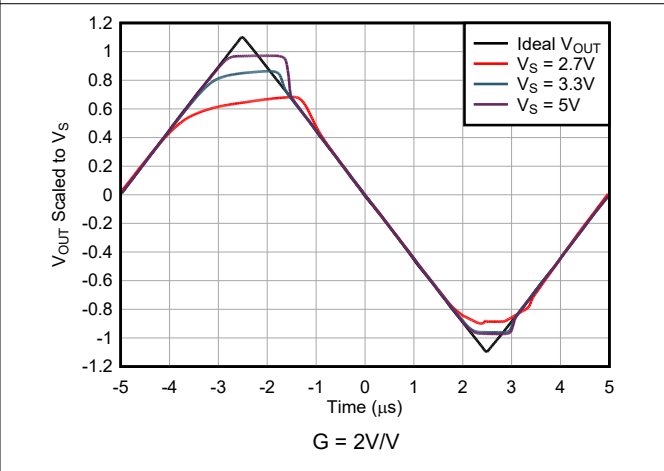

Figure 6-22. Overload Recovery Time vs Supply Voltage

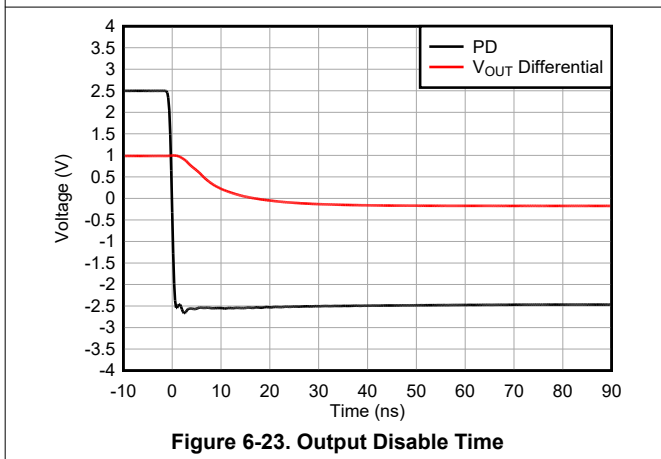

Figure 6-23. Output Disable Time

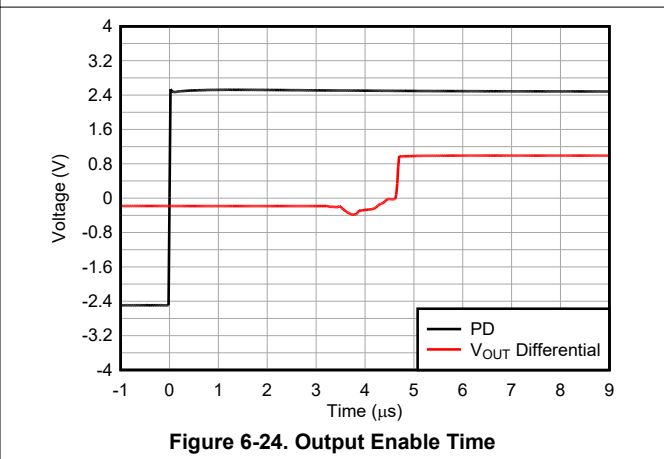

Figure 6-24. Output Enable Time

6.6 Typical Characteristics (continued)

at $T_A = 25^\circ\text{C}$, $V_{S+} - V_{S-} = 5\text{V}$, $V_{OCM} = \text{open (midsupply)}$, $R_F = 1\text{k}\Omega$, $G = 1\text{V/V}$, $V_O = 2V_{PP}$, $R_L = 1\text{k}\Omega$, and $\overline{\text{PD}} = \text{logic high}$ (unless otherwise noted)

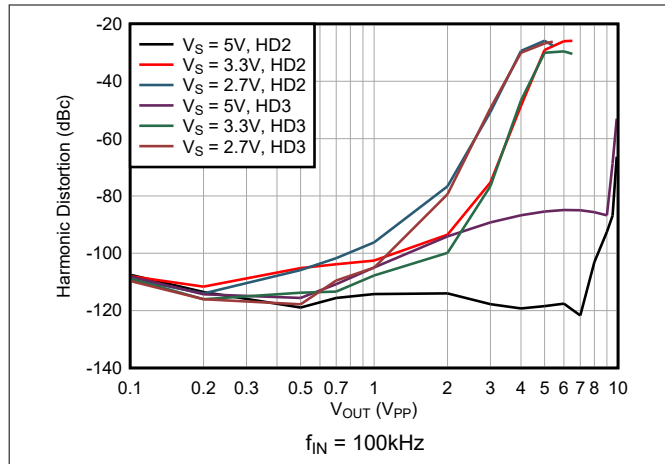

Figure 6-25. Harmonic Distortion vs Output Amplitude

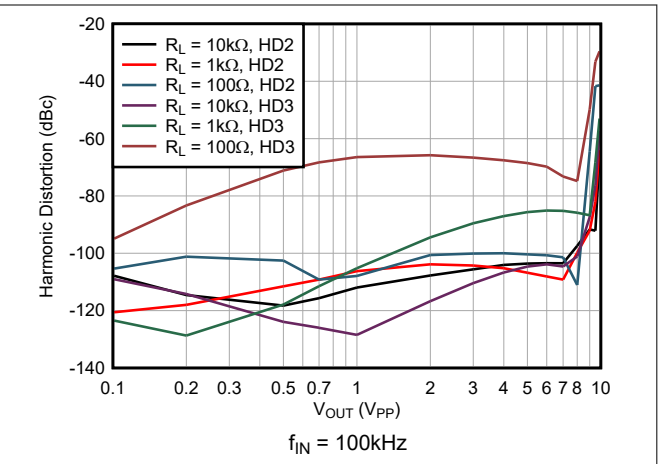

Figure 6-26. Harmonic Distortion vs Output Amplitude

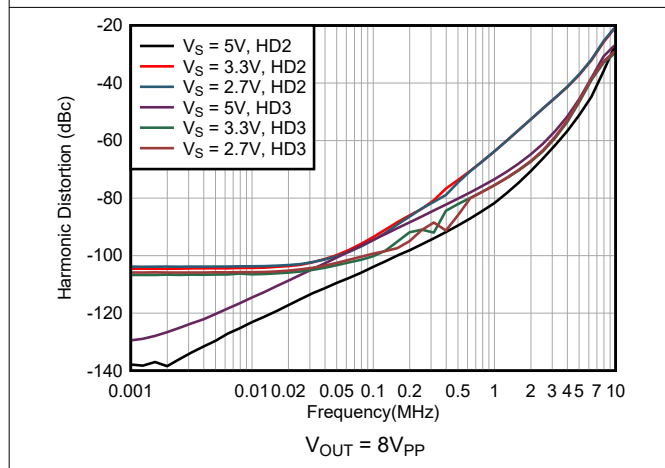

Figure 6-27. Harmonic Distortion vs Frequency

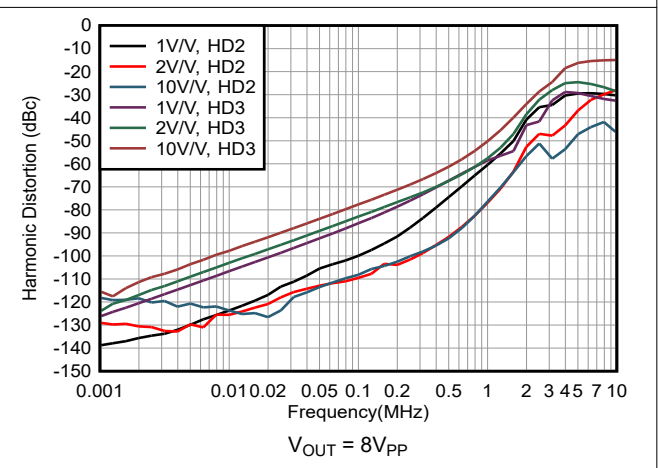

Figure 6-28. Harmonic Distortion vs Frequency

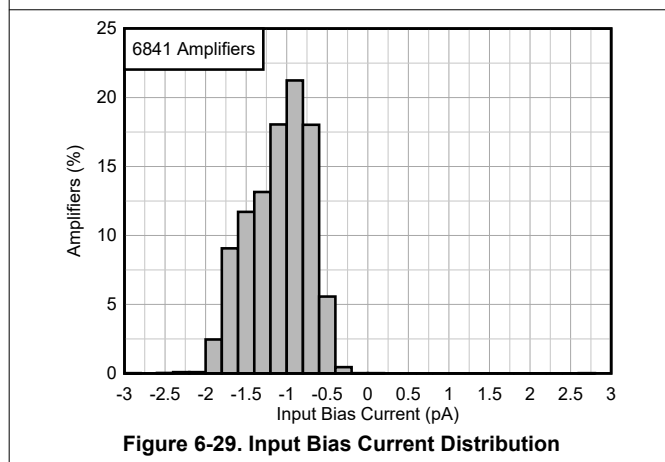

Figure 6-29. Input Bias Current Distribution

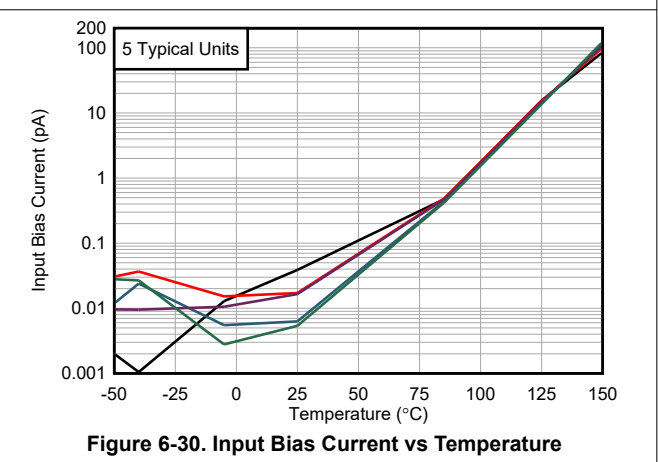

Figure 6-30. Input Bias Current vs Temperature

6.6 Typical Characteristics (continued)

at $T_A = 25^\circ\text{C}$, $V_{S+} - V_{S-} = 5\text{V}$, $V_{\text{OCM}} = \text{open (midsupply)}$, $R_F = 1\text{k}\Omega$, $G = 1\text{V/V}$, $V_O = 2V_{\text{PP}}$, $R_L = 1\text{k}\Omega$, and $\overline{\text{PD}} = \text{logic high}$ (unless otherwise noted)

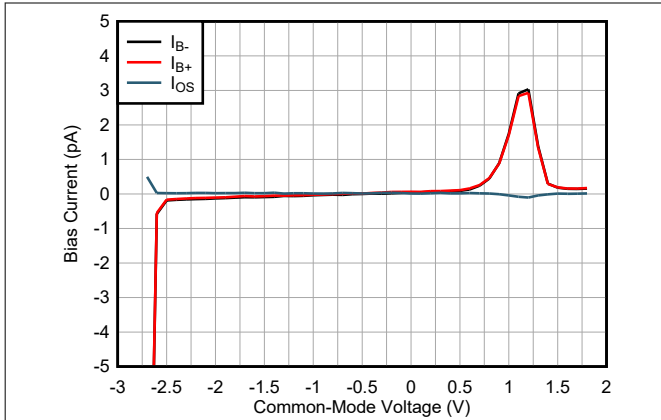

Figure 6-31. Input Bias Current vs Input Common-Mode Voltage

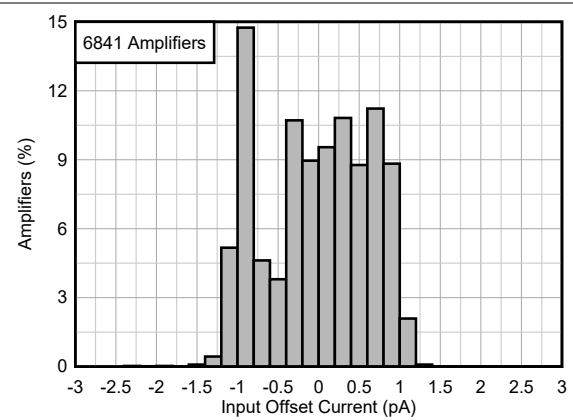

Figure 6-32. Input Offset Current Distribution

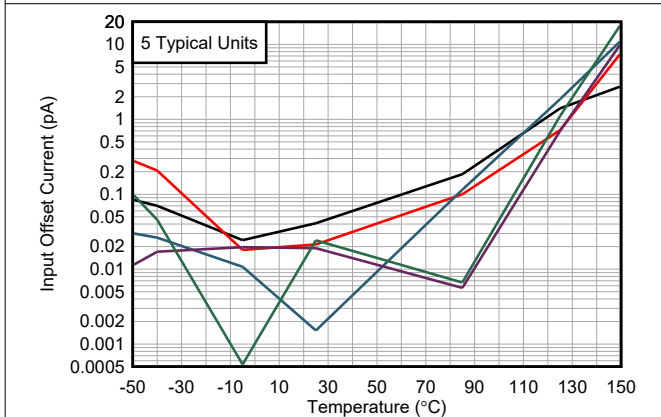

Figure 6-33. Input Offset Current vs Temperature

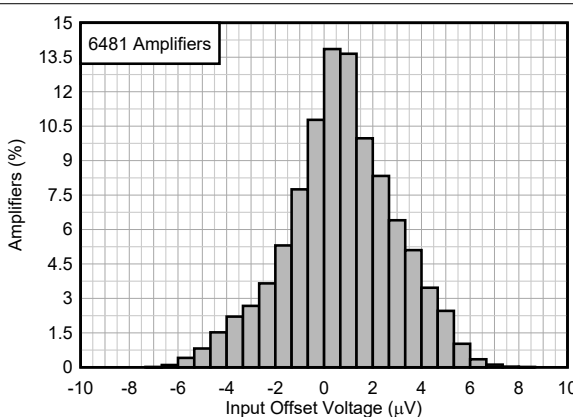

Figure 6-34. THS4536 Offset Voltage Distribution

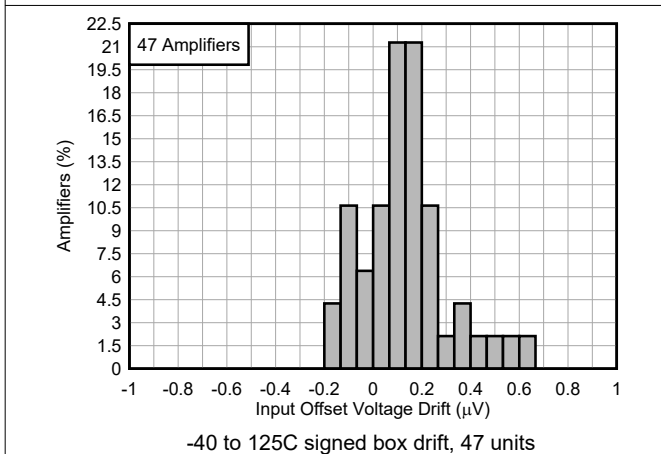

Figure 6-35. THS4536 Offset Voltage Drift Distribution

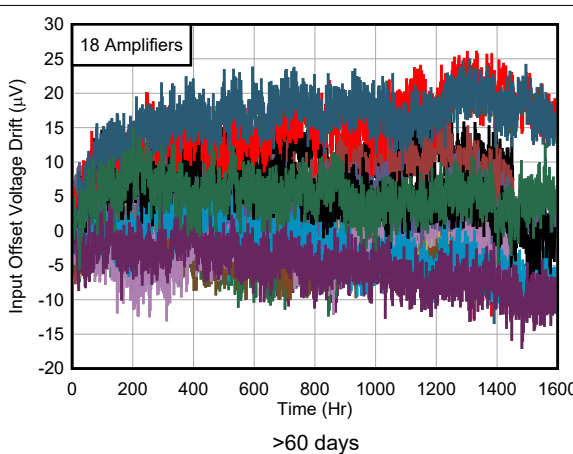

Figure 6-36. THS4536 Long Term Drift

6.6 Typical Characteristics (continued)

at $T_A = 25^\circ\text{C}$, $V_{S+} - V_{S-} = 5\text{V}$, $V_{OCM} = \text{open (midsupply)}$, $R_F = 1\text{k}\Omega$, $G = 1\text{V/V}$, $V_O = 2V_{PP}$, $R_L = 1\text{k}\Omega$, and $\overline{\text{PD}} = \text{logic high}$ (unless otherwise noted)

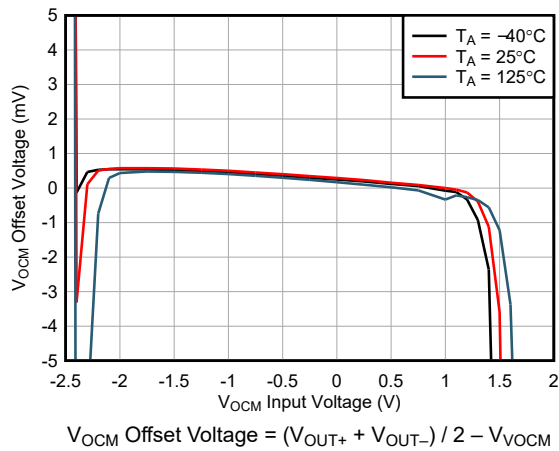

Figure 6-37. Output Common-Mode Offset Voltage vs VOCM Voltage

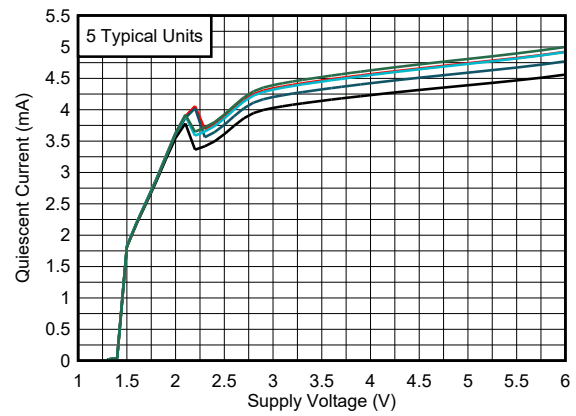

Figure 6-38. Quiescent Current vs Supply Voltage

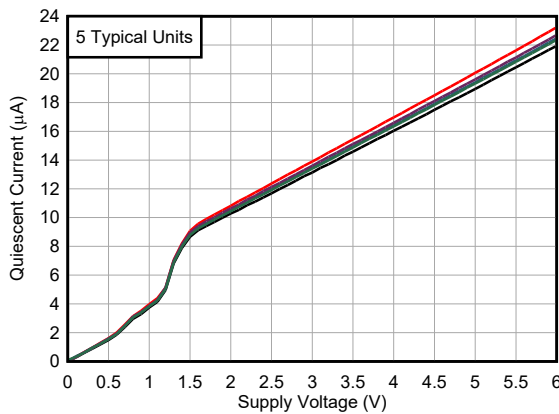

Figure 6-39. Power-Down Quiescent Current vs Supply Voltage

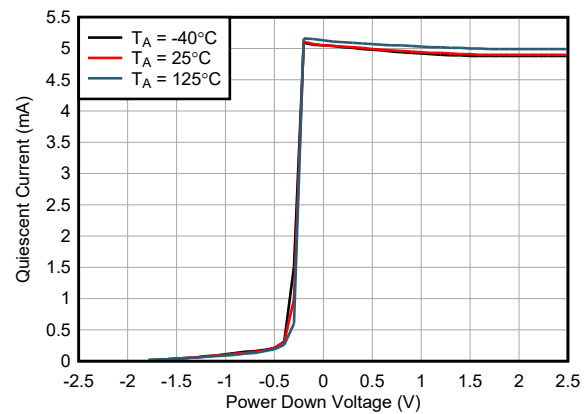

Figure 6-40. Quiescent Current vs PD Voltage

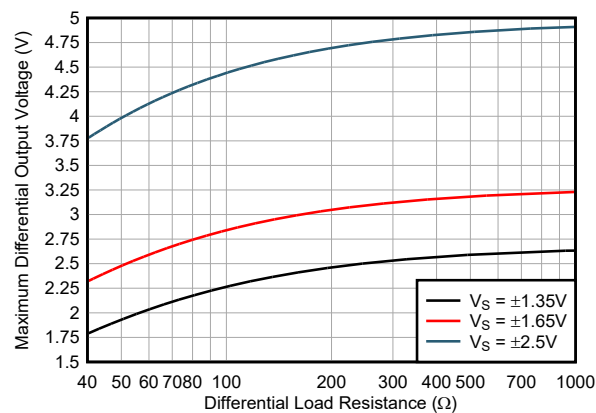

Figure 6-41. Maximum Differential Output Voltage vs Differential Load Resistance

7 Detailed Description

7.1 Overview

The THS4536 is a fully differential CMOS amplifier designed to optimize dc and ac performance for driving < 2MSPS ADCs. The base version of this device, THS4535, is designed for single-ended to differential conversions in low-side current sensing or funnel amplifier applications. When dc precision is needed, the THS4536 provides a temperature trimmed version of the device. This temperature trimming, along with state of the art package construction, allows applications in data acquisition systems (DAQ) to minimize errors due to temperature drift, long-term drift, or applications that are sensitive to overtemperature shifts in bias current or input offset current.

7.2 Functional Block Diagram

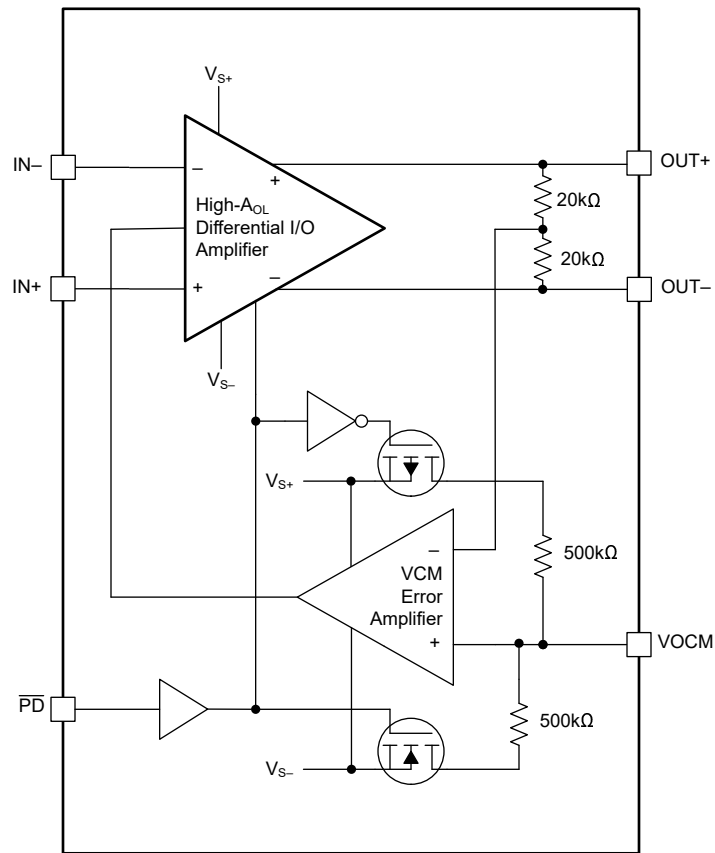

7.3 Feature Description

7.3.1 Output Common-Mode

The THS4536 output common-mode pin allows the FDA to servo the output pins (V_{OUT+} and V_{OUT-}) so that the average voltage of these two pins matches the V_{OCM} pin. V_{OCM} is especially useful when the input common-mode voltage does not match the desired output common-mode voltage, such as in ADC drive. For example, in the case of a high-side current sense measurement there is often a large common-mode voltage followed by a small differential voltage. If the high-side shunt resistor common-mode voltage is close to the positive supply (Figure 7-1), set the V_{OCM} pin to $\frac{1}{2}$ the ADC reference voltage, and the differential output voltage is gained up and balanced around the V_{OCM} voltage.

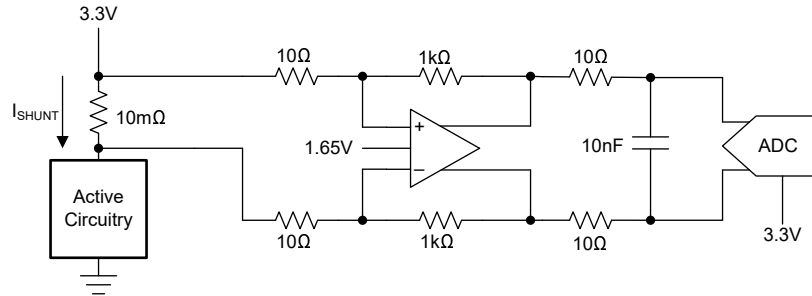

Figure 7-1. High-Side Current-Sense Example

Note

The THS4536 V_{OCM} pin has an internal voltage divider with two 500kΩ resistors, one connected to V_{S+} and one connected to V_{S-} . If this pin is left unconnected connect a 1nF capacitor from V_{OCM} to ground to help stabilize the pin voltage internally.

7.4 Device Functional Modes

7.4.1 Power-Down Mode

Assert the power-down ($\overline{\text{PD}}$) pin to the desired voltage for proper power-down mode operation. A physical internal pullup resistor of 500k is provided internally on the $\overline{\text{PD}}$ pin so that if the pin is floated, the device defaults to the ON state. Tie the $\overline{\text{PD}}$ pin to the positive supply voltage for applications that simply require the device to power on when the supplies are present. For single-supply operation, a minimum of 0.5V within the positive supply is required.

The disable operation is referenced from the negative supply. For an OFF state condition, the disable control pin must be 0.5V within the negative supply. [Figure 7-2](#) shows how to use a microcontroller to toggle the power-down pin on the THS4536 by simply connecting a digital input/output (DIO) directly to the $\overline{\text{PD}}$ pin.

Note

If using a microcontroller to enable the THS4536, ensure that the threshold voltages (V_{IH} and V_{IL}) in the *Electrical Characteristics* are satisfied.

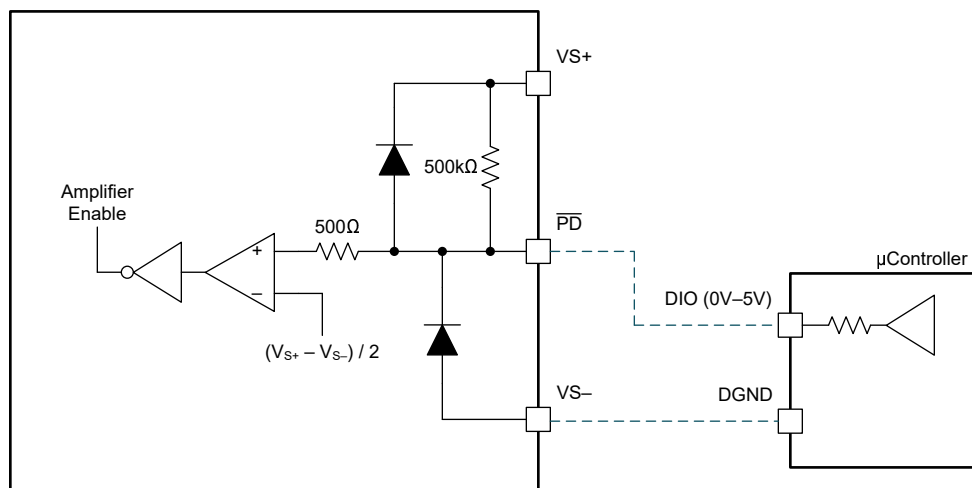

Figure 7-2. $\overline{\text{PD}}$ Pin Schematic

8 Application and Implementation

Note

Information in the following applications sections is not part of the TI component specification, and TI does not warrant its accuracy or completeness. TI's customers are responsible for determining suitability of components for their purposes, as well as validating and testing their design implementation to confirm system functionality.

8.1 Application Information

Most applications for the THS4536 strive to deliver the best dynamic range in a design that delivers the desired signal processing along with adequate phase margin for the amplifier. The following sections detail some of the design issues with analysis and guidelines for improved performance.

8.1.1 Output Common-Mode Voltage

The output common-mode voltage pin sets the dc output voltage of the THS4536. A voltage applied to the VO_{CM} pin from a low-impedance source is used to directly set the output common-mode voltage. If left floating, then the VO_{CM} pin defaults to the midrail voltage, defined as:

$$\frac{(V_{CC+}) + (V_{CC-})}{2} \quad (1)$$

To minimize common-mode noise, connect a 0.1µF bypass capacitor to the VO_{CM} pin. Output common-mode voltage causes additional current to flow in the feedback resistor network. This current is supplied by the output stage of the amplifier; therefore, additional power dissipation is created. For commonly-used feedback resistance values, this current is easily supplied by the amplifier. The additional internal power dissipation created by this current is potentially significant in some applications, and dictates the use of the PowerPAD integrated circuit package to effectively control self-heating.

8.1.1.1 Resistor Matching

Resistor matching is important in FDAs to maintain good output balance. An ideal differential output signal implies the two outputs of the FDA are exactly equal in amplitude and shifted 180° in phase. Any imbalance in amplitude or phase between the two output signals results in an undesirable common-mode signal at the output. The output balance error is a measure of how well the outputs are balanced, and is defined as the ratio of the output common-mode voltage to the output differential signal.

$$\text{Output Balance Error} = \frac{\left(\frac{V_{OUT+} - V_{OUT-}}{2}\right)}{V_{OUT+} - V_{OUT-}} \quad (2)$$

At low frequencies, resistor mismatch is the primary contributor to output balance errors. Additionally CMRR, PSRR, and HD2 performance diminish if resistor mismatch occurs. Therefore, to optimize performance, use 1% tolerance resistors or better. [Table 8-1](#) provides the recommended resistor values to use for a particular gain.

Table 8-1. Recommended Resistor Values

GAIN (V/V)	R _G (Ω)	R _F (Ω)
1	1000	1000
2	499	1000
5	200	1000
10	100	1000

8.1.2 Data Converters

Driving data converters is one of the most popular applications for fully-differential amplifiers. [Figure 8-1](#) shows a typical configuration of an FDA attached to a differential analog-to-digital converter (ADC).

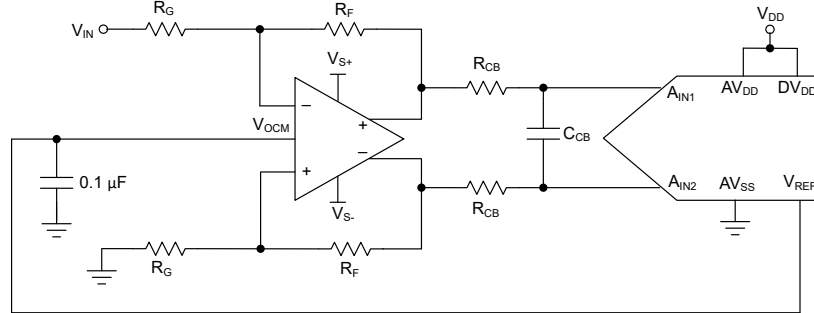

Figure 8-1. Fully-Differential Amplifier Attached to a Differential ADC

FDAs are able to operate with a single supply. V_{OCM} defaults to the midrail voltage, $V_{CC} / 2$. The differential output is fed into a data converter. This method eliminates the use of a transformer in the circuit. If the ADC has a reference voltage output (V_{REF}), then connect V_{REF} directly to the V_{OCM} of the amplifier using a bypass capacitor to reduce broadband common-mode noise.

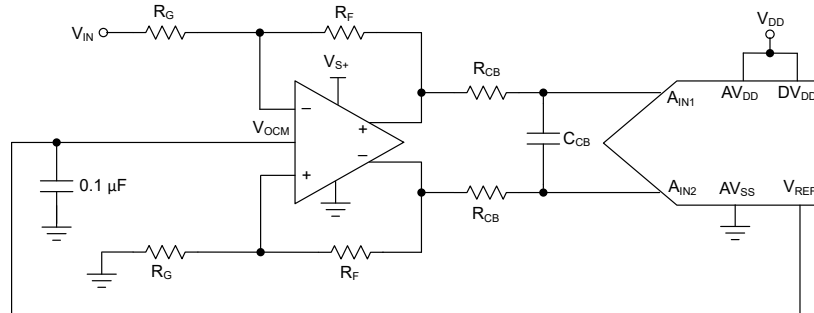

Figure 8-2. Fully-Differential Amplifier Using a Single Supply

8.1.3 Single-Supply Applications

For proper operation, do not exceed the common-mode input voltage range of the device. However, some single-supply applications require that the input voltage exceeds the common-mode input voltage range. In this case, to bring the common-mode input voltage within the specifications of the amplifier, use the circuit configuration of [Figure 8-3](#).

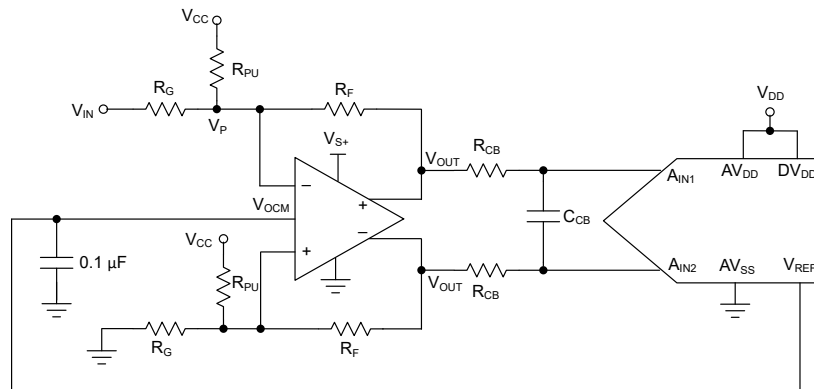

Figure 8-3. Circuit With Improved Common-Mode Input Voltage

Use [Equation 3](#) to calculate R_{PU} :

$$R_{PU} = \frac{V_P - V_{CC}}{(V_{IN} - V_P) \frac{1}{R_G} + (V_{OUT} - V_P) \frac{1}{R_F}} \quad (3)$$

8.2 Typical Application

8.2.1 Typical Application

Single-to-differential conversion is a typical use-case for fully differential amplifiers (FDAs) as a result of the FDA output balance, output common-mode servo, and ADC output drive capabilities. Many higher-precision and higher-speed ADCs are moving towards differential inputs to improve common-mode noise immunity and to improve dynamic range. Figure 8-4 shows how the FDA architecture allows easy conversion by simply connecting the signal source to one input and grounding the other input.

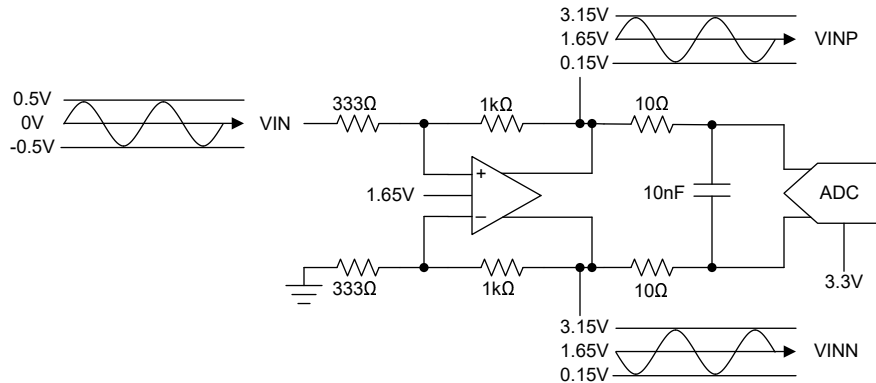

Figure 8-4. THS4536 Single-to-Differential Conversion

8.2.1.1 Design Requirements

Table 8-2. Design Parameters

DESIGN PARAMETERS	VALUE
Input voltage	1V _{PP}
ADC supply voltage	3.3V
ADC input differential voltage	Balanced 6V _{PP}
ADC input common-mode voltage	1.65V

8.2.1.2 Detailed Design Procedure

The configuration shown in Figure 8-4 creates a differential gain of 3, while maintaining a balanced output at the middle of the ADC range. The differential gain (A_{V_DIFF}) is set by the ratio of the input resistors, $R_{IN} = 333\Omega$, and the feedback resistors, $R_{FB} = 1k\Omega$, for a total of $3V/V$. The output common-mode is shifted to whatever voltage is specified on the V_{OUTCM} pin, which is $\frac{1}{2}$ the ADC reference (1.65V for this example). The inherent architecture of the FDA makes two signals that are 180° out of phase with a maximum and minimum range of 0.15V to 3.15V. The total range of the ADC is not used in this example to provide headroom for the ADC or output range of the FDA if running on a 3.3V supply, but an alternative gain can be used to get an exact peak-to-peak voltage to match the ADC, if desired.

An alternative design to the FDA is a dual amplifier used in a two-op-amp instrumentation amplifier configuration. This design uses two amplifiers: one amplifier in a noninverting configuration that gains up the input signal, and one amplifier in an inverting configuration that inverts the output of the first amplifier. Figure 8-5 shows there are some sizable downsides to this approach. First, the output common-mode voltage depends on the input common-mode voltage because the noninverting amplifier's output common-mode is dependent on the input common-mode voltage. This design shortcoming can be remedied by changing the dc bias of the gain resistor for the noninverting amplifier, as shown in Figure 8-5 with -0.875V, but an additional bias voltage is required. Failure to shift the output common-mode voltage correctly can result in signal loss due to output clipping on the noninverting amplifier when the input voltage is close to the negative rail. Second, there is a phase imbalance between the noninverting amplifier and the inverting amplifiers in this circuit. As more gain is required of this circuit, the noninverting amplifier gets slower as the gain increases while the inverting amplifier gain stays the

same. Such gain and phase imbalances potentially manifest as distortion errors, limit signal bandwidth, and are often exacerbated with loading.

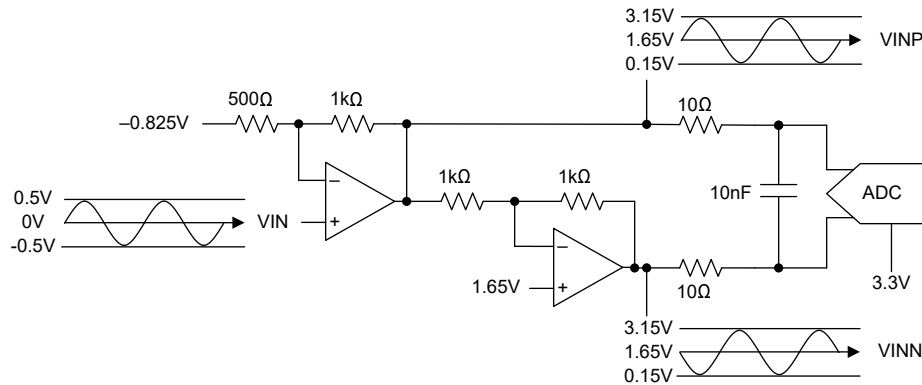

Figure 8-5. Dual Amplifier Single-to-Dual Conversion

8.2.1.3 Application Curves

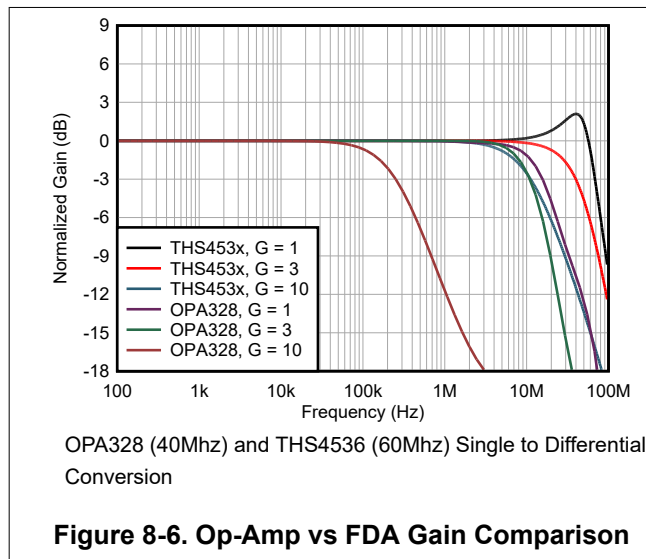

Figure 8-6. Op-Amp vs FDA Gain Comparison

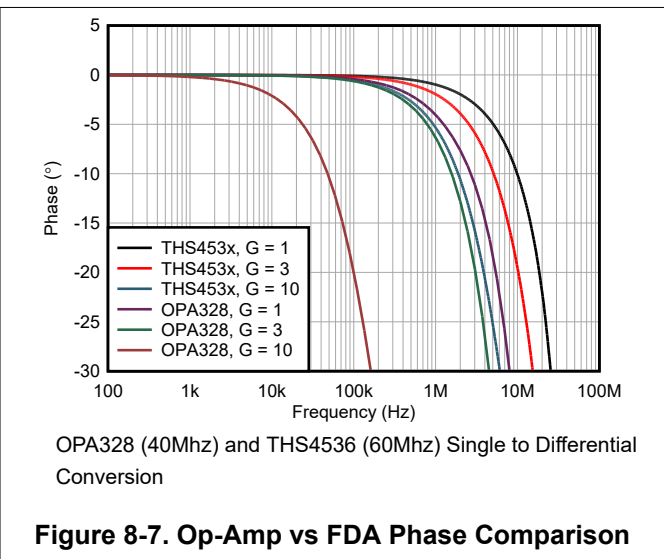

Figure 8-7. Op-Amp vs FDA Phase Comparison

8.3 Power Supply Recommendations

The THS4536 is designed to operate on power supplies ranging from $\pm 1.35\text{V}$ to $\pm 2.75\text{V}$ (single-ended supplies of 2.7V to 5.5V). Use a power-supply accuracy of 5% or better. When operated on a board with high-speed digital signals, provide isolation between digital signal noise and the analog input pins. The THS4536 is connected to power supplies through the VS+ and VS– pins. Decouple each supply pin to ground as close as possible to the device with a low-inductance, surface-mount ceramic capacitor of approximately 10nF. When vias are used to connect the bypass capacitors to a ground plane, configure the vias for minimal parasitic inductance. One method of reducing via inductance is to use multiple vias. For broadband systems, two capacitors per supply pin are advised.

To avoid undesirable signal transients, do not power on the THS4536 with large inputs signals present. Careful planning of system power on sequencing is especially important to avoid damage to ADC inputs when an ADC is used in the application.

8.4 Layout

8.4.1 Layout Guidelines

8.4.1.1 Board Layout Recommendations

Similar to all high-speed devices, best system performance is achieved with close attention to board layout. The *DEM-FDA-DGK-EVM* user's guide provides a good example of high-frequency layout techniques as a reference. This EVM includes numerous extra elements and features for characterization purposes that do not apply to some applications. General high-speed signal path layout suggestions include:

- Continuous ground planes are preferred for signal routing with matched impedance traces for longer runs; however, both ground and power planes must be opened up around the capacitive sensitive input and output device pins. When the signal goes to a resistor, parasitic capacitance becomes more of a band-limiting issue and less of a stability issue.
- Good high-frequency decoupling capacitors ($0.1\mu\text{F}$) are required to a ground plane at the device power pins. Additional higher-value capacitors ($2.2\mu\text{F}$) are also required but can be placed further from the device power pins and shared among devices. For best high-frequency decoupling, consider X2Y supply decoupling capacitors that offer a much higher self-resonance frequency over standard capacitors.
- Differential signal routing over any appreciable distance must use microstrip layout techniques with matched impedance traces.
- The input summing junctions are very sensitive to parasitic capacitance. Any R_G elements must connect into the summing junction with minimal trace length to the device pin side of the resistor. The other side of the R_G elements can have more trace length if needed to the source or to GND.

8.4.2 Layout Examples

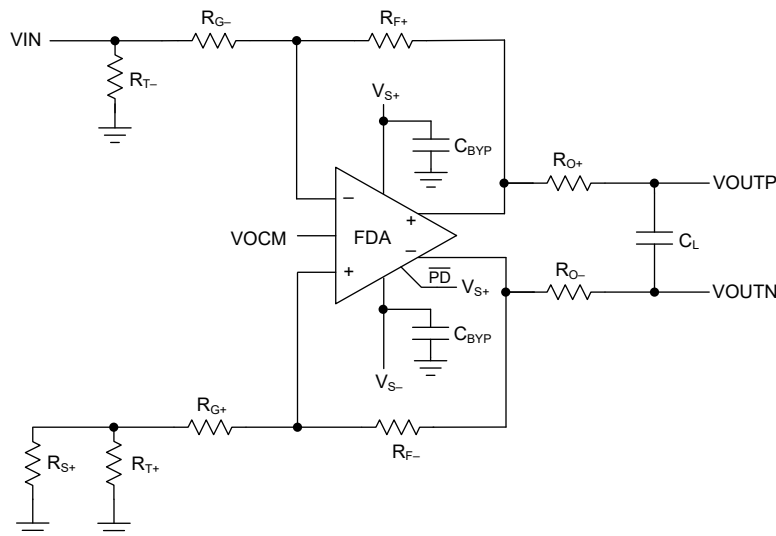

Figure 8-8. Representative Schematic for the Layout Recommendations

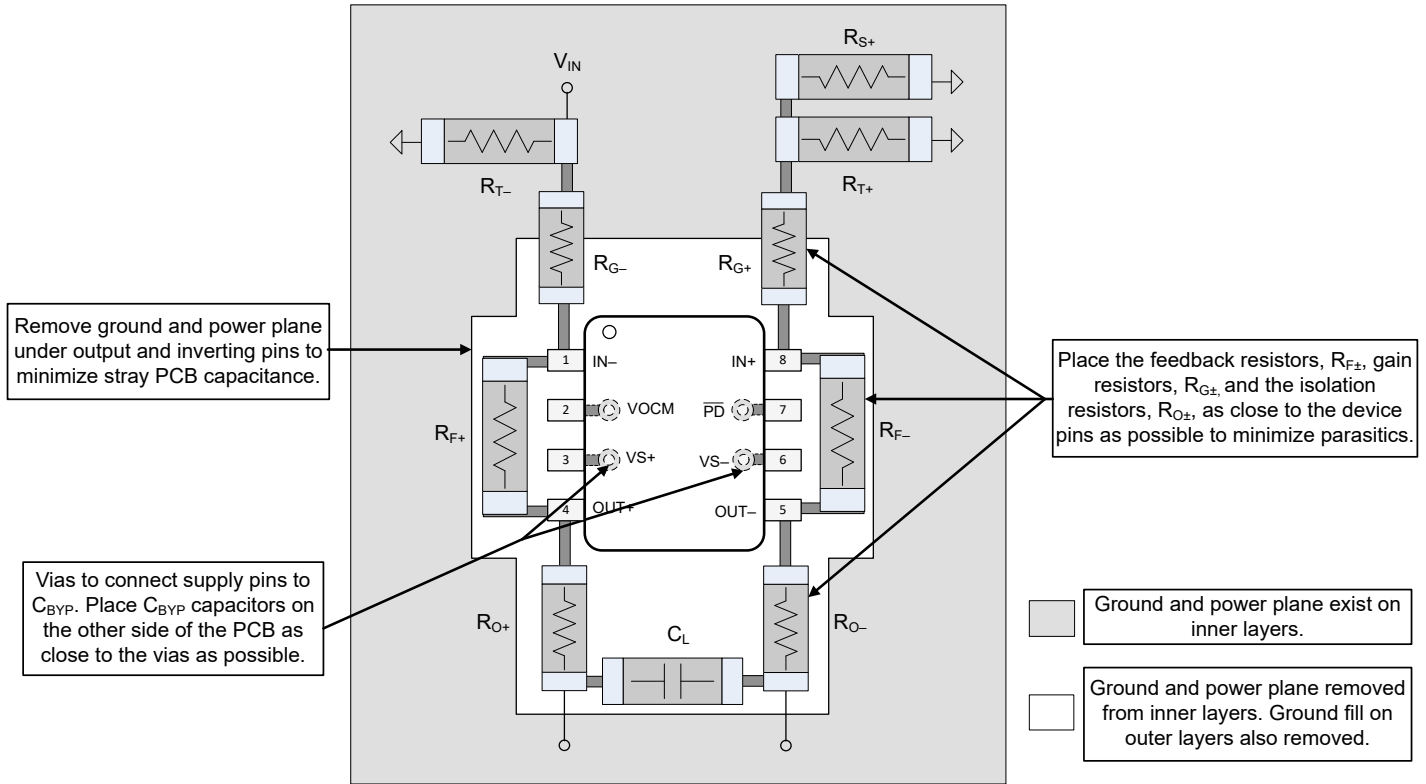

Figure 8-9. Layout Recommendations (DGK Package)

9 Device and Documentation Support

9.1 Receiving Notification of Documentation Updates

To receive notification of documentation updates, navigate to the device product folder on ti.com. Click on *Notifications* to register and receive a weekly digest of any product information that has changed. For change details, review the revision history included in any revised document.

9.2 Support Resources

TI E2E™ [support forums](#) are an engineer's go-to source for fast, verified answers and design help — straight from the experts. Search existing answers or ask your own question to get the quick design help you need.

Linked content is provided "AS IS" by the respective contributors. They do not constitute TI specifications and do not necessarily reflect TI's views; see TI's [Terms of Use](#).

9.3 Trademarks

TI E2E™ is a trademark of Texas Instruments.
All trademarks are the property of their respective owners.

9.4 Electrostatic Discharge Caution



This integrated circuit can be damaged by ESD. Texas Instruments recommends that all integrated circuits be handled with appropriate precautions. Failure to observe proper handling and installation procedures can cause damage.

ESD damage can range from subtle performance degradation to complete device failure. Precision integrated circuits may be more susceptible to damage because very small parametric changes could cause the device not to meet its published specifications.

9.5 Glossary

[TI Glossary](#) This glossary lists and explains terms, acronyms, and definitions.

10 Revision History

NOTE: Page numbers for previous revisions may differ from page numbers in the current version.

DATE	REVISION	NOTES
December 2025	*	Initial Release

11 Mechanical, Packaging, and Orderable Information

The following pages include mechanical, packaging, and orderable information. This information is the most current data available for the designated devices. This data is subject to change without notice and revision of this document. For browser-based versions of this data sheet, refer to the left-hand navigation.

PACKAGING INFORMATION

Orderable part number	Status (1)	Material type (2)	Package Pins	Package qty Carrier	RoHS (3)	Lead finish/ Ball material (4)	MSL rating/ Peak reflow (5)	Op temp (°C)	Part marking (6)
THS4536DGKR	Active	Production	VSSOP (DGK) 8	2500 LARGE T&R	Yes	NIPDAU	Level-2-260C-1 YEAR	-40 to 125	4536
THS4536RUNR	Active	Production	QFN (RUN) 10	3000 LARGE T&R	Yes	NIPDAU	Level-1-260C-UNLIM	-40 to 125	4536

(1) **Status:** For more details on status, see our [product life cycle](#).

(2) **Material type:** When designated, preproduction parts are prototypes/experimental devices, and are not yet approved or released for full production. Testing and final process, including without limitation quality assurance, reliability performance testing, and/or process qualification, may not yet be complete, and this item is subject to further changes or possible discontinuation. If available for ordering, purchases will be subject to an additional waiver at checkout, and are intended for early internal evaluation purposes only. These items are sold without warranties of any kind.

(3) **RoHS values:** Yes, No, RoHS Exempt. See the [TI RoHS Statement](#) for additional information and value definition.

(4) **Lead finish/Ball material:** Parts may have multiple material finish options. Finish options are separated by a vertical ruled line. Lead finish/Ball material values may wrap to two lines if the finish value exceeds the maximum column width.

(5) **MSL rating/Peak reflow:** The moisture sensitivity level ratings and peak solder (reflow) temperatures. In the event that a part has multiple moisture sensitivity ratings, only the lowest level per JEDEC standards is shown. Refer to the shipping label for the actual reflow temperature that will be used to mount the part to the printed circuit board.

(6) **Part marking:** There may be an additional marking, which relates to the logo, the lot trace code information, or the environmental category of the part.

Multiple part markings will be inside parentheses. Only one part marking contained in parentheses and separated by a "~" will appear on a part. If a line is indented then it is a continuation of the previous line and the two combined represent the entire part marking for that device.

Important Information and Disclaimer:The information provided on this page represents TI's knowledge and belief as of the date that it is provided. TI bases its knowledge and belief on information provided by third parties, and makes no representation or warranty as to the accuracy of such information. Efforts are underway to better integrate information from third parties. TI has taken and continues to take reasonable steps to provide representative and accurate information but may not have conducted destructive testing or chemical analysis on incoming materials and chemicals. TI and TI suppliers consider certain information to be proprietary, and thus CAS numbers and other limited information may not be available for release.

In no event shall TI's liability arising out of such information exceed the total purchase price of the TI part(s) at issue in this document sold by TI to Customer on an annual basis.

TAPE AND REEL INFORMATION

QUADRANT ASSIGNMENTS FOR PIN 1 ORIENTATION IN TAPE

*All dimensions are nominal

Device	Package Type	Package Drawing	Pins	SPQ	Reel Diameter (mm)	Reel Width W1 (mm)	A0 (mm)	B0 (mm)	K0 (mm)	P1 (mm)	W (mm)	Pin1 Quadrant
THS4536DGKR	VSSOP	DGK	8	2500	330.0	12.4	5.3	3.4	1.4	8.0	12.0	Q1
THS4536RUNR	QFN	RUN	10	3000	180.0	8.4	2.3	2.3	1.15	4.0	8.0	Q1

TAPE AND REEL BOX DIMENSIONS

*All dimensions are nominal

Device	Package Type	Package Drawing	Pins	SPQ	Length (mm)	Width (mm)	Height (mm)
THS4536DGKR	VSSOP	DGK	8	2500	353.0	353.0	32.0
THS4536RUNR	QFN	RUN	10	3000	210.0	185.0	35.0

DGK0008A



PACKAGE OUTLINE

VSSOP - 1.1 mm max height

SMALL OUTLINE PACKAGE



NOTES:

PowerPAD is a trademark of Texas Instruments.

1. All linear dimensions are in millimeters. Any dimensions in parenthesis are for reference only. Dimensioning and tolerancing per ASME Y14.5M.
2. This drawing is subject to change without notice.
3. This dimension does not include mold flash, protrusions, or gate burrs. Mold flash, protrusions, or gate burrs shall not exceed 0.15 mm per side.
4. This dimension does not include interlead flash. Interlead flash shall not exceed 0.25 mm per side.
5. Reference JEDEC registration MO-187.

EXAMPLE BOARD LAYOUT

DGK0008A

™ VSSOP - 1.1 mm max height

SMALL OUTLINE PACKAGE



LAND PATTERN EXAMPLE
EXPOSED METAL SHOWN
SCALE: 15X



4214862/A 04/2023

NOTES: (continued)

6. Publication IPC-7351 may have alternate designs.
7. Solder mask tolerances between and around signal pads can vary based on board fabrication site.
8. Vias are optional depending on application, refer to device data sheet. If any vias are implemented, refer to their locations shown on this view. It is recommended that vias under paste be filled, plugged or tented.
9. Size of metal pad may vary due to creepage requirement.

EXAMPLE STENCIL DESIGN

DGK0008A

TM VSSOP - 1.1 mm max height

SMALL OUTLINE PACKAGE



SOLDER PASTE EXAMPLE
SCALE: 15X

4214862/A 04/2023

NOTES: (continued)

11. Laser cutting apertures with trapezoidal walls and rounded corners may offer better paste release. IPC-7525 may have alternate design recommendations.
12. Board assembly site may have different recommendations for stencil design.

GENERIC PACKAGE VIEW

RUN 10

WQFN - 0.8 mm max height

2 X 2, 0.5 mm pitch

PLASTIC QUAD FLATPACK - NO LEAD

This image is a representation of the package family, actual package may vary.
Refer to the product data sheet for package details.

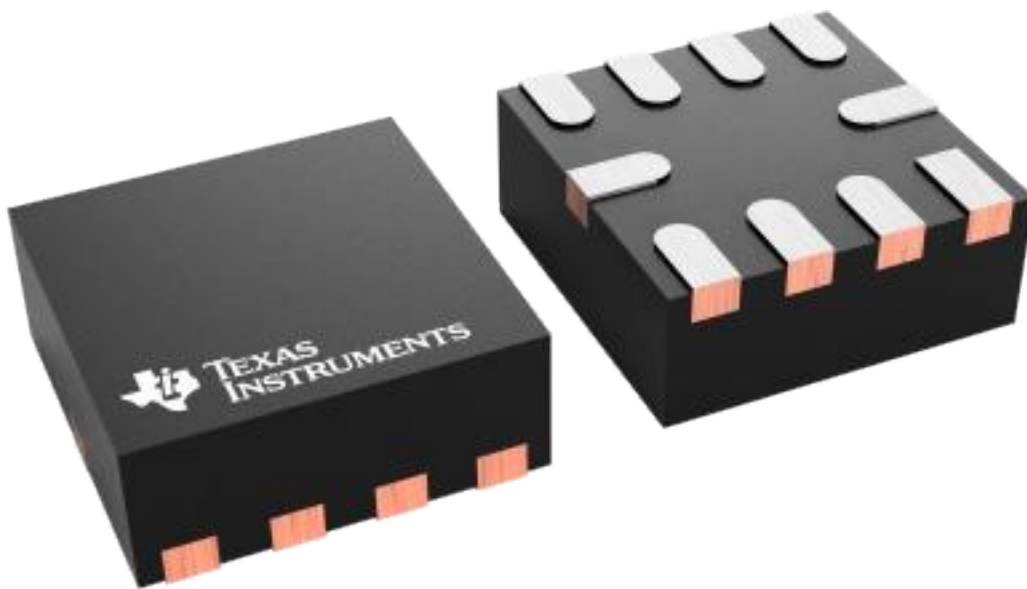

4228249/A

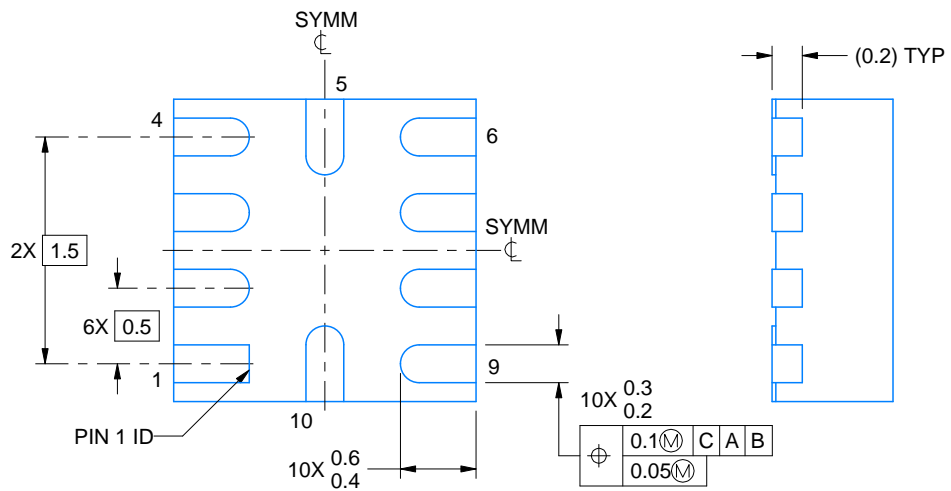
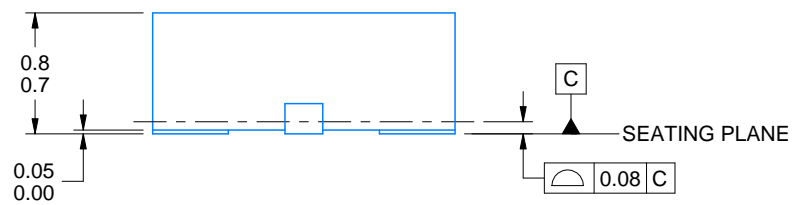
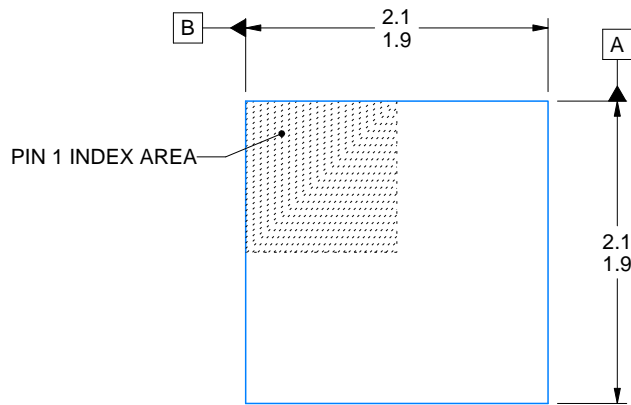
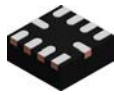

4220470/A 05/2020

NOTES:

1. All linear dimensions are in millimeters. Any dimensions in parenthesis are for reference only. Dimensioning and tolerancing per ASME Y14.5M.
2. This drawing is subject to change without notice.

EXAMPLE BOARD LAYOUT

RUN0010A

WQFN - 0.8 mm max height

PLASTIC QUAD FLATPACK - NO LEAD

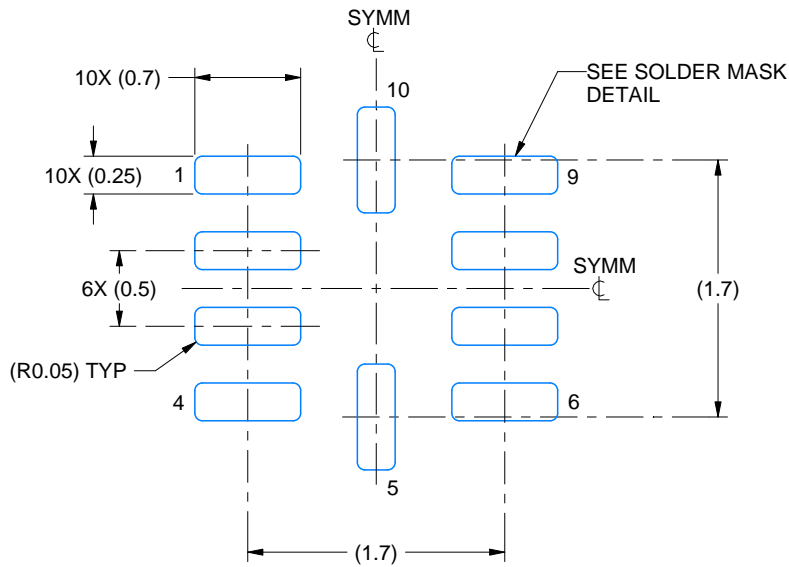

LAND PATTERN EXAMPLE
EXPOSED METAL SHOWN
SCALE: 20X

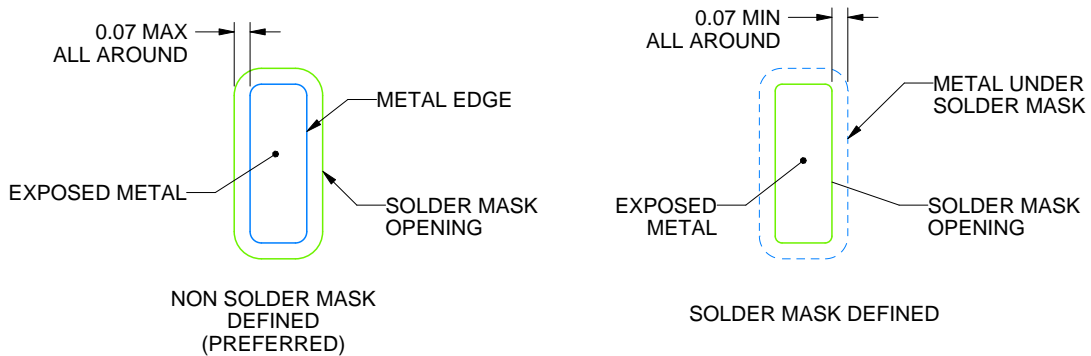

SOLDER MASK DETAILS

4220470/A 05/2020

NOTES: (continued)

- This package is designed to be soldered to a thermal pad on the board. For more information, see Texas Instruments literature number SLUA271 (www.ti.com/lit/slua271).

EXAMPLE STENCIL DESIGN

RUN0010A

WQFN - 0.8 mm max height

PLASTIC QUAD FLATPACK - NO LEAD

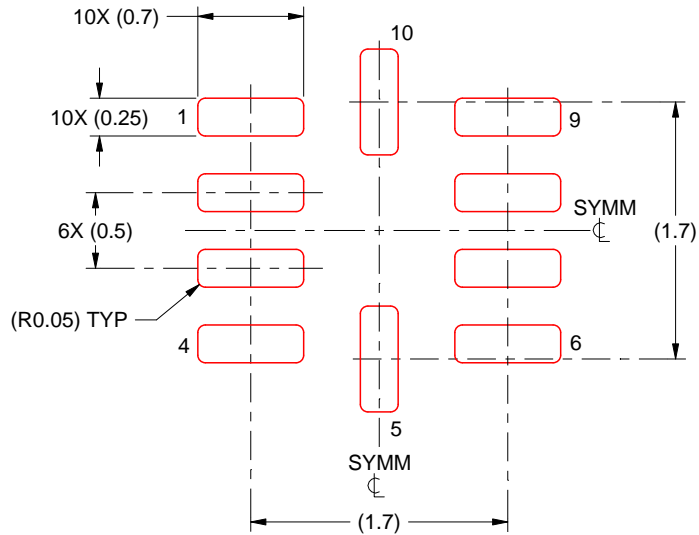

SOLDER PASTE EXAMPLE
BASED ON 0.125 MM THICK STENCIL
SCALE: 20X

4220470/A 05/2020

NOTES: (continued)

4. Laser cutting apertures with trapezoidal walls and rounded corners may offer better paste release. IPC-7525 may have alternate design recommendations.

IMPORTANT NOTICE AND DISCLAIMER

TI PROVIDES TECHNICAL AND RELIABILITY DATA (INCLUDING DATASHEETS), DESIGN RESOURCES (INCLUDING REFERENCE DESIGNS), APPLICATION OR OTHER DESIGN ADVICE, WEB TOOLS, SAFETY INFORMATION, AND OTHER RESOURCES "AS IS" AND WITH ALL FAULTS, AND DISCLAIMS ALL WARRANTIES, EXPRESS AND IMPLIED, INCLUDING WITHOUT LIMITATION ANY IMPLIED WARRANTIES OF MERCHANTABILITY, FITNESS FOR A PARTICULAR PURPOSE OR NON-INFRINGEMENT OF THIRD PARTY INTELLECTUAL PROPERTY RIGHTS.

These resources are intended for skilled developers designing with TI products. You are solely responsible for (1) selecting the appropriate TI products for your application, (2) designing, validating and testing your application, and (3) ensuring your application meets applicable standards, and any other safety, security, regulatory or other requirements.

These resources are subject to change without notice. TI grants you permission to use these resources only for development of an application that uses the TI products described in the resource. Other reproduction and display of these resources is prohibited. No license is granted to any other TI intellectual property right or to any third party intellectual property right. TI disclaims responsibility for, and you fully indemnify TI and its representatives against any claims, damages, costs, losses, and liabilities arising out of your use of these resources.

TI's products are provided subject to [TI's Terms of Sale](#), [TI's General Quality Guidelines](#), or other applicable terms available either on [ti.com](#) or provided in conjunction with such TI products. TI's provision of these resources does not expand or otherwise alter TI's applicable warranties or warranty disclaimers for TI products. Unless TI explicitly designates a product as custom or customer-specified, TI products are standard, catalog, general purpose devices.

TI objects to and rejects any additional or different terms you may propose.

Copyright © 2026, Texas Instruments Incorporated

Last updated 10/2025