

TCA39306 Dual Bidirectional I²C Bus and SMBus Voltage-Level Translator

1 Features

- 2-Bit bidirectional translator for SDA and SCL lines in mixed-mode I²C applications
- Standard-mode, fast-mode, and fast-mode plus I²C and SMBus compatible
- I³C compatible (12.5 MHz supported)
- Allows voltage-level translation between
 - 0.9-V V_{REF1} and 1.8-V, 2.5-V, 3.3-V, or 5-V V_{REF2}
 - 1.2-V V_{REF1} and 1.8-V, 2.5-V, 3.3-V, or 5-V V_{REF2}
 - 1.8-V V_{REF1} and 2.5-V, 3.3-V, or 5-V V_{REF2}
 - 2.5-V V_{REF1} and 3.3-V or 5-V V_{REF2}
 - 3.3-V V_{REF1} and 5-V V_{REF2}
- Provides bidirectional voltage translation with no direction Pin
- Low ON-state resistance between input and output ports provides less signal distortion
- Open-drain I²C I/O ports (SCL1, SDA1, SCL2, and SDA2)
- 5-V Tolerant I²C I/O ports to support mixed-mode signal operation
- High-impedance SCL1, SDA1, SCL2, and SDA2 pins for EN = Low
- Lockup-free operation for isolation when EN = Low
- Flow-through pinout for ease of printed-circuit-board trace routing
- ESD Protection Exceeds JESD 22
 - 2000-V human-body model (A114-A)
 - 1000-V charged-device model (C101)

2 Applications

- I²C, SMBus, PMBus, MDIO, UART, low-speed SDIO, GPIO, and other two-signal interfaces
- [Servers](#)
- [Routers](#) (telecom switching equipment)
- [Personal computers](#)
- [Industrial automation](#)

3 Description

The TCA39306 is a dual bidirectional voltage-level translator compatible with I²C, SMBus, and I³C with an enable (EN) input, and is operational from 0.9-V to 3.3-V V_{REF1} and 1.8-V to 5.5-V V_{REF2} .

The device allows bidirectional voltage translations between 0.85 V and 5 V, without the use of a direction pin. The low ON-state resistance (R_{ON}) of the switch allows connections to be made with minimal propagation delay. When EN is high, the translator switch is ON, and the SCL1 and SDA1 I/O are connected to the SCL2 and SDA2 I/O, respectively, allowing bidirectional data flow between ports. When EN is low, the translator switch is off, and a high-impedance state exists between ports.

In addition to voltage translation, the TCA39306 can be used to isolate a higher speed bus from a lower speed bus by controlling the EN pin to disconnect the slower bus during fast-mode communication.

Package Information

PART NUMBER	PACKAGE ⁽¹⁾	BODY SIZE (NOM)
TCA39306	VSSOP (8)	2.30 mm x 2.00 mm
	SOT-23 (8)	2.90 mm x 1.60 mm
	X2SON (8)	1.35 mm x 0.80 mm

(1) For all available packages, see the orderable addendum at the end of the datasheet.

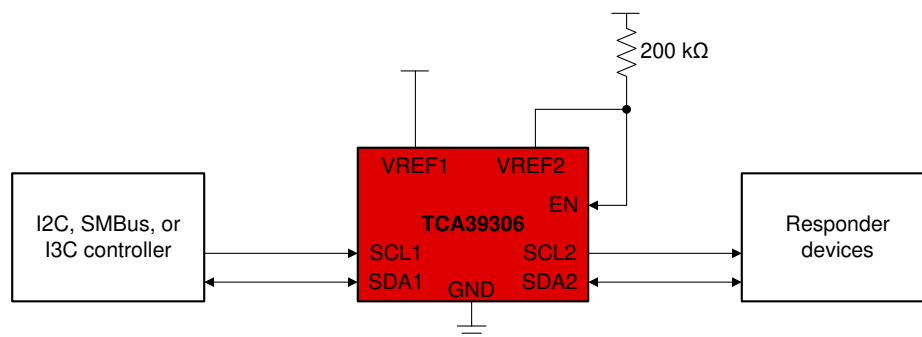

Simplified Application Diagram



Table of Contents

1 Features	1	8.3 Feature Description.....	16
2 Applications	1	8.4 Device Functional Modes.....	16
3 Description	1	9 Application and Implementation	17
4 Revision History	2	9.1 Application Information.....	17
5 Pin Configuration and Functions	3	9.2 Typical Application.....	17
6 Specifications	4	9.3 Systems Examples: I3C Usage Considerations.....	20
6.1 Absolute Maximum Ratings.....	4	9.4 Power Supply Recommendations.....	22
6.2 ESD Ratings.....	4	9.5 Layout.....	22
6.3 Recommended Operating Conditions.....	4	10 Device and Documentation Support	24
6.4 Thermal Information.....	5	10.1 Receiving Notification of Documentation Updates.....	24
6.5 Electrical Characteristics.....	5	10.2 Support Resources.....	24
6.6 Switching Characteristics.....	6	10.3 Trademarks.....	24
6.7 Typical Characteristics.....	8	10.4 Electrostatic Discharge Caution.....	24
7 Parameter Measurement Information	9	10.5 Glossary.....	24
8 Detailed Description	11	11 Mechanical, Packaging, and Orderable Information	24
8.1 Overview.....	11		
8.2 Functional Block Diagram.....	16		

4 Revision History

NOTE: Page numbers for previous revisions may differ from page numbers in the current version.

Changes from Revision A (August 2021) to Revision B (March 2023)	Page
• Deleted the "Product Preview" note from the SOT-23 in the <i>Package Information</i> table.....	1
• Added DDF (SOT-23) to the <i>Thermal Information</i> table.....	5

Changes from Revision * (June 2021) to Revision A (August 2021)	Page
• Changed the document from <i>Advanced Information</i> to <i>Production</i> data.....	1

5 Pin Configuration and Functions

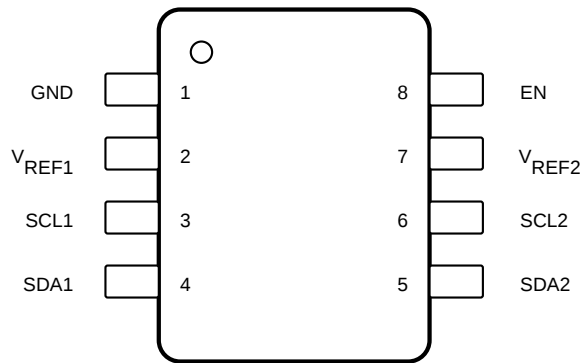
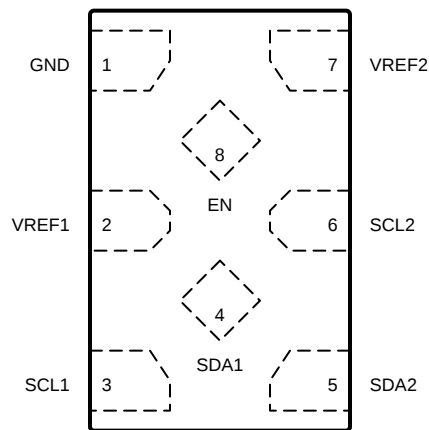

Figure 5-1. DDF Package, 8-Pin SOT, Top View



Figure 5-2. DCU Package, 8-Pin VSSOP, Top View



Not to scale

Figure 5-3. DTM Package, 8-Pin X2SON, Top View

Table 5-1. Pin Functions

NAME	PIN NO.		I/O	DESCRIPTION
	DCU, DDF	DTM		
EN	8	8	I	Switch enable input
GND	1	1	—	Ground, 0 V
SCL1	3	3	I/O	Serial clock, low-voltage side
SCL2	6	6	I/O	Serial clock, high-voltage side
SDA1	4	4	I/O	Serial data, low-voltage side
SDA2	5	5	I/O	Serial data, high-voltage side
V _{REF1}	2	2	I	Low-voltage-side reference supply voltage for SCL1 and SDA1
V _{REF2}	7	7	I	High-voltage-side reference supply voltage for SCL2 and SDA2

6 Specifications

6.1 Absolute Maximum Ratings

over operating free-air temperature range (unless otherwise noted)⁽¹⁾

		MIN	MAX	UNIT
V _{REF1}	DC reference voltage range	-0.5	7	V
V _{REF2}	DC reference bias voltage range	-0.5	7	V
V _I	Input voltage range ⁽²⁾	-0.5	7	V
V _{I/O}	Input-output voltage range ⁽²⁾	-0.5	7	V
	Continuous channel current		128	mA
I _{IK}	Input Clamp Current (V _I < 0)		-50	mA
T _{J(Max)}	Junction temperature		150	°C
T _{stg}	Storage temperature	-65	150	°C

- (1) Operation outside the Absolute Maximum Ratings may cause permanent device damage. Absolute Maximum Ratings do not imply functional operation of the device at these or any other conditions beyond those listed under Recommended Operating Conditions. If used outside the Recommended Operating Conditions but within the Absolute Maximum Ratings, the device may not be fully functional, and this may affect device reliability, functionality, performance, and shorten the device lifetime.
- (2) The input and input-output negative voltage ratings may be exceeded if the input and output current ratings are observed.

6.2 ESD Ratings

			VALUE	UNIT
V _(ESD)	Electrostatic discharge	Human body model (HBM), per ANSI/ESDA/ JEDEC JS-001 ⁽¹⁾	±2000	V
		Charged device model (CDM), per ANSI/ESDA/ JEDEC JS-002 ⁽²⁾	±1000	

- (1) JEDEC document JEP155 states that 500-V HBM allows safe manufacturing with a standard ESD control process.
- (2) JEDEC document JEP157 states that 250-V CDM allows safe manufacturing with a standard ESD control process.

6.3 Recommended Operating Conditions

over operating free-air temperature range (unless otherwise noted)

			MIN	MAX	UNIT
V _{I/O}	Input-output voltage	SCL1, SDA1, SCL2, SDA2	0	5.5	V
V _{REF1} ⁽¹⁾	Reference Voltage		0	5.5	V
V _{REF2} ⁽¹⁾	Reference Voltage		0	5.5	V
EN-Switch ⁽²⁾	Switch mode enable voltage (Switch mode enable voltage)		1.5	5.5	V
EN	Enable input voltage		0	5.5	V
I _{PASS}	Pass switch current			64	mA
T _A	Ambient temperature		-40	125	°C

- (1) To support translation, V_{REF1} supports 0.85 V to V_{REF2} - 0.6 V. V_{REF2} must be between V_{REF1} + 0.6 V to 5.5 V. See Typical Application for more information.
- (2) To support switching, V_{REF1} and V_{REF2} Do not need to be connected. EN pin should use a voltage not less than 1.5V when the switch mode is to be enabled. Enabled voltage on this pin should be equal to 1.5V or I/O supply voltage, whichever is higher.

6.4 Thermal Information

THERMAL METRIC ⁽¹⁾		TCA39306			UNIT
		DCU	DDF	DTM	
		8 PINS	8 PINS	8 PINS	
R _{θJA}	Junction-to-ambient thermal resistance	275.5	273.0	289.5	°C/W
R _{θJC(top)}	Junction-to-case (top) thermal resistance	127.1	180.7	185.5	°C/W
R _{θJB}	Junction-to-board thermal resistance	186.9	188.4	193.8	°C/W
Ψ _{JT}	Junction-to-top characterization parameter	65.7	47.8	27.4	°C/W
Ψ _{JB}	Junction-to-board characterization parameter	185.9	187.8	193.2	°C/W

(1) For more information about traditional and new thermal metrics, see the [Semiconductor and IC Package Thermal Metrics](#) application report.

6.5 Electrical Characteristics

over operating free-air temperature range (unless otherwise noted)

PARAMETER		TEST CONDITIONS			MIN	TYP ⁽¹⁾	MAX	UNIT	
V _{IK}	Input clamp voltage	I _I = -18 mA	EN = 0 V		-1.2	0		V	
I _{IH}	Input leakage current	V _I = 5 V, V _O = 0V	EN = 0 V			5		μA	
V _T	Threshold voltage	I _O = 500 μA	V _I = 0.1 V, V _O = 0 V, Find V _{EN} where I _O = 500 μA		0.7	1.0		V	
C _{I(EN)}	Input capacitance	V _I = 3 V or 0 V			11			pF	
C _{IO(off)}	Off capacitance	SCLn, SDAn	V _O = 3 V or 0 V	EN = 0 V		4	6	pF	
C _{IO(on)}	On capacitance	SCLn, SDAn	V _O = 3 V or 0 V	EN = 3 V		10.5	12.5	pF	
R _{ON} ⁽²⁾	On-state resistance	SCLn, SDAn (-40 to 125C)	V _I = 0 V ⁽³⁾	I _O = 64 mA	EN = 4.5 V	3.5	5.5	Ω	
			V _I = 0 V ⁽³⁾	I _O = 64 mA	EN = 3 V	4.7	7	Ω	
			V _I = 0 V ⁽³⁾	I _O = 64 mA	EN = 2.3 V	6.3	9.5	Ω	
			V _I = 0 V ⁽³⁾	I _O = 15 mA	EN = 1.5 V	25.5	32	Ω	
			V _I = 2.4 V ⁽⁴⁾	I _O = 15 mA	EN = 4.5 V	1	6	15	Ω
			V _I = 2.4 V ⁽⁴⁾	I _O = 15 mA	EN = 3 V	20	50	75	Ω
			V _I = 1.7 V ⁽⁴⁾	I _O = 15 mA	EN = 2.3 V	20	55	75	Ω

6.5 Electrical Characteristics (continued)

over operating free-air temperature range (unless otherwise noted)

PARAMETER			TEST CONDITIONS			MIN	TYP (1)	MAX	UNIT
R _{ON}	On-state resistance	SCLn, SDAn	V _I = 0 V, VCC2 = 5 V ⁽⁵⁾	I _O = 64 mA	VCC1 = 1 V		5	25	Ω
					VCC1 = 1.8 V		4	10	
					VCC1 = 2.5 V		3	8	
					VCC1 = 3.3 V		3	7	
				I _O = 32 mA	VCC1 = 1 V		5	10	Ω
					VCC1 = 1.8 V		4	9	
					VCC1 = 2.5 V		3	8	
					VCC1 = 3.3 V		3	7	
			V _I = 1.8 V, VCC2 = 5 V ⁽⁵⁾	I _O = 15 mA	VCC1 = 3.3 V		4	13	Ω
			V _I = 1 V, VCC2 = 3.3 V ⁽⁵⁾	I _O = 10 mA	VCC1 = 1.8 V		7	24	Ω
V _I = 0 V, VCC2 = 3.3 V ⁽⁵⁾	I _O = 10 mA	VCC1 = 1 V		5	18	Ω			
V _I = 0 V, VCC2 = 1.8 V ⁽⁵⁾	I _O = 10 mA	VCC1 = 1 V		6	19	Ω			

(1) All typical values are at T_A = 25°C.

(2) Measured by the voltage drop between the SCL1 and SCL2, or SDA1 and SDA2 terminals, at the indicated current through the switch. Minimum ON-state resistance is determined by the lowest voltage of the two terminals.

(3) Measured in current source configuration only. See [Figure 7-1](#)

(4) Measured in current sink configuration only. See [Figure 7-1](#)

(5) Measured in application connected current source configuration only. See [Figure 7-2](#)

6.6 Switching Characteristics

over operating free-air temperature range (unless otherwise noted)

PARAMETER		TEST CONDITIONS		MIN	TYP	MAX	UNIT
T _{PLH}	Low-to-high propagation delay ⁽¹⁾	V _{CC1} = 0.85 V, V _{CC2} = 1.98 V, R _{L_Input} = 1.35 kΩ	C _L = 15 pF			13	ns
			C _L = 50 pF			32	
		V _{CC1} = 0.85 V, V _{CC2} = 3.6 V, R _{L_Input} = 1.35 kΩ	C _L = 15 pF			15	ns
			C _L = 50 pF			45	
		V _{CC1} = 0.85 V, V _{CC2} = 5.5 V, R _{L_Input} = 1.35 kΩ	C _L = 15 pF			20	ns
			C _L = 50 pF			46	
		V _{CC1} = 1.65 V, V _{CC2} = 3.6 V, R _{L_Input} = 1.35 kΩ	C _L = 15 pF			8	ns
			C _L = 50 pF			20	
		V _{CC1} = 1.65 V, V _{CC2} = 5.5 V, R _{L_Input} = 1.35 kΩ	C _L = 15 pF			15	ns
			C _L = 50 pF			35	
		V _{CC1} = 3 V, V _{CC2} = 5.5 V, R _{L_Input} = 1.35 kΩ	C _L = 15 pF			2	ns
			C _L = 50 pF			5	

6.6 Switching Characteristics (continued)

over operating free-air temperature range (unless otherwise noted)

PARAMETER		TEST CONDITIONS		MIN	TYP	MAX	UNIT	
T _{PHL}	High-to-low propagation delay ⁽¹⁾	V _{CC1} = 0.85 V, V _{CC2} = 1.98 V, R _{L_Input} = 1.35 kΩ	C _L = 15 pF			3	ns	
			C _L = 50 pF			4		
		V _{CC1} = 0.85 V, V _{CC2} = 3.6 V, R _{L_Input} = 1.35 kΩ	C _L = 15 pF			3	ns	
			C _L = 50 pF			5		
		V _{CC1} = 0.85 V, V _{CC2} = 5.5 V, R _{L_Input} = 1.35 kΩ	C _L = 15 pF			3	ns	
			C _L = 50 pF			5		
		V _{CC1} = 1.65 V, V _{CC2} = 3.6 V, R _{L_Input} = 1.35 kΩ	C _L = 15 pF			2	ns	
			C _L = 50 pF			3		
		V _{CC1} = 1.65 V, V _{CC2} = 5.5 V, R _{L_Input} = 1.35 kΩ	C _L = 15 pF			3	ns	
			C _L = 50 pF			3		
		V _{CC1} = 3 V, V _{CC2} = 5.5 V, R _{L_Input} = 1.35 kΩ	C _L = 15 pF				1.5	ns
			C _L = 50 pF				2	

(1) Measured with an application propagation delay setup. See [Figure 7-3](#)

6.7 Typical Characteristics

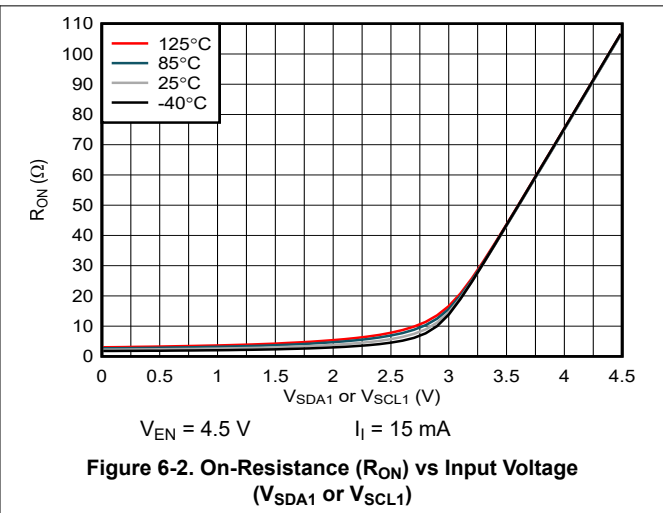
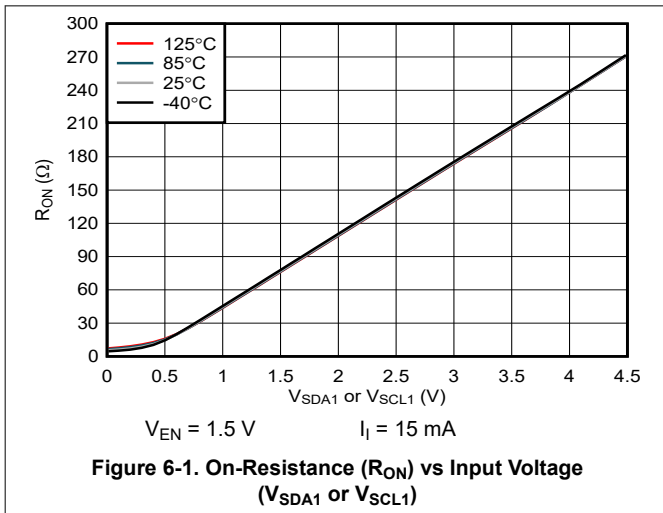

7 Parameter Measurement Information

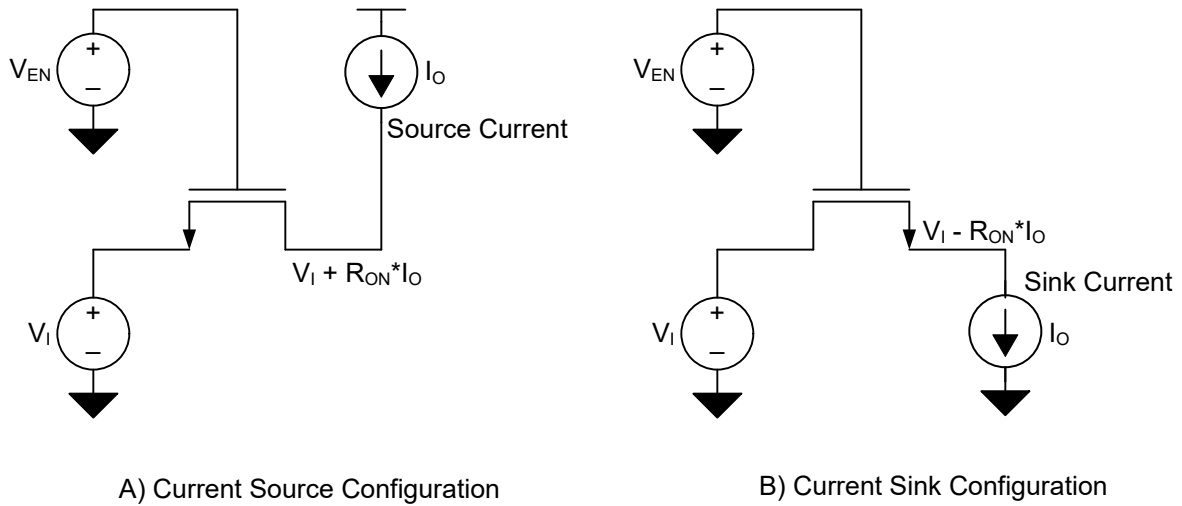

Figure 7-1. Current Source and Current Sink Configurations for Direct R_{ON} Measurements

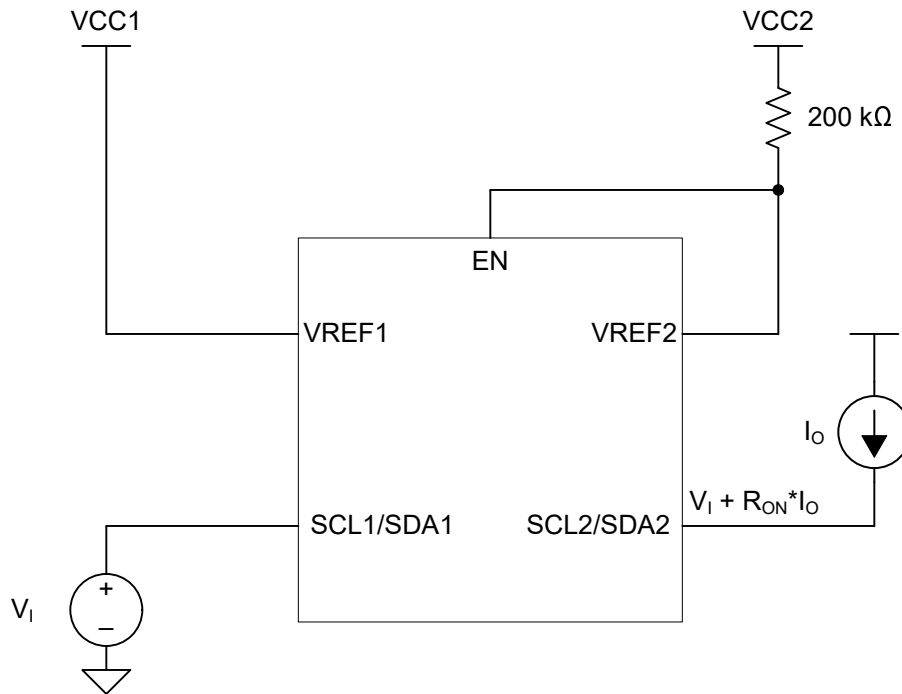

Figure 7-2. Application Setup for R_{ON} Delay

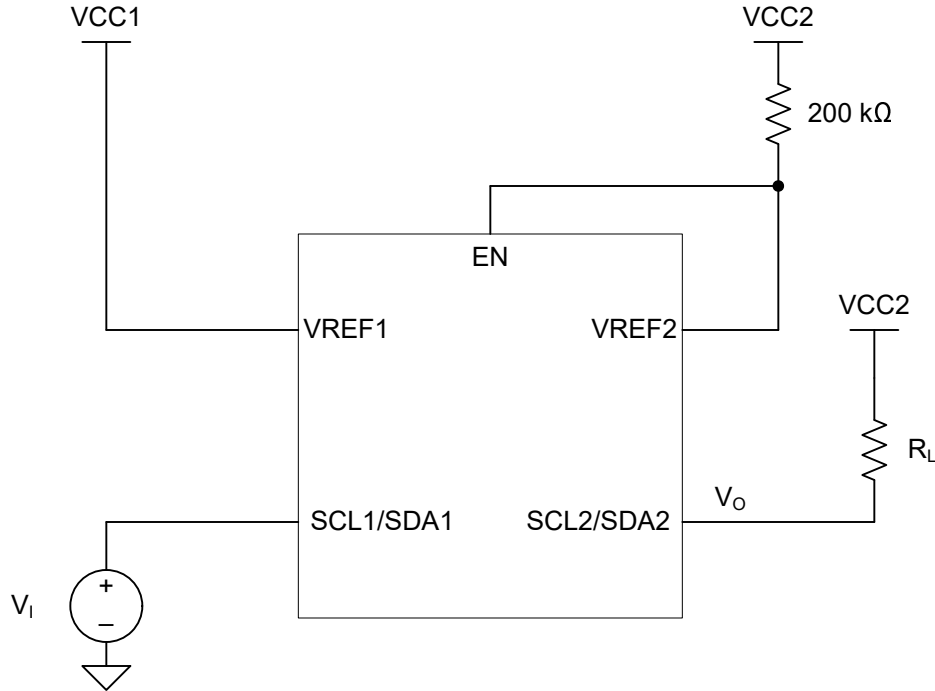
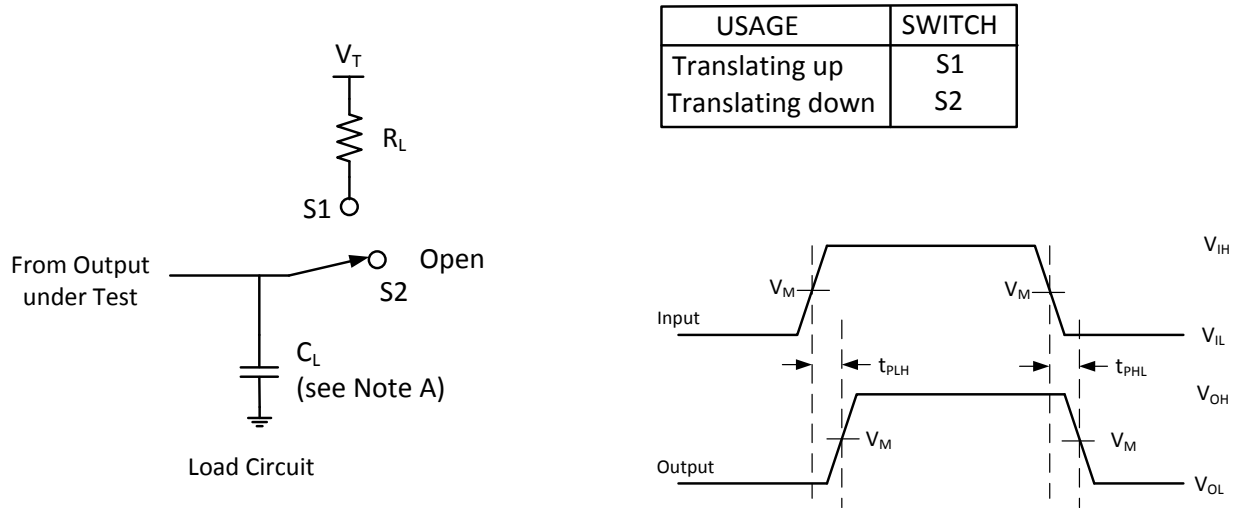

Figure 7-3. Application Setup for Propagation Delays Delay



- NOTES: A. C_L includes probe and jig capacitance
 B. All input pulses are supplied by generators having the following characteristics: $PRR \leq 10 \text{ MHz}$, $Z_o = 50 \Omega$, $t_r \leq 2 \text{ ns}$, $t_f \leq 2 \text{ ns}$.
 C. The outputs are measured one at a time, with one transition per measurement.

Figure 7-4. Load Circuit for Outputs

8 Detailed Description

8.1 Overview

The TCA39306 is a dual bidirectional voltage-level translator compatible with I²C, SMBus, and I³C with an enable (EN) input, and is operational from 0.9-V to 3.3-V V_{REF1} and 1.8-V to 5.5-V V_{REF2} .

The device allows bidirectional voltage translations between 0.85 V and 5 V, without the use of a direction pin. The low ON-state resistance (R_{ON}) of the switch allows connections to be made with minimal propagation delay. When EN is high, the translator switch is ON, and the SCL1 and SDA1 I/O are connected to the SCL2 and SDA2 I/O, respectively, allowing bidirectional data flow between ports. When EN is low, the translator switch is off, and a high-impedance state exists between ports.

In addition to voltage translation, the TCA39306 can be used to isolate a higher speed bus from a lower speed bus by controlling the EN pin to disconnect the slower bus during fast-mode communication.

In I²C applications, the bus capacitance limit of 400 pF for Standard and Fast Modes, 550 pF for Fast Mode Plus restricts the number of devices and bus length. The capacitive load on both sides of the device must be taken into account when approximating the total load of the system, specifying the sum of both sides is under 400/550 pF.

Both the SDA and SCL channels of the device have the same electrical characteristics, and there is minimal deviation from one output to another in voltage or propagation delay. This is a benefit over discrete-transistor voltage-translation solutions, because the fabrication of the switch is symmetrical.

8.1.1 Definition of threshold voltage

This document references a threshold voltage denoted as V_{th} , which appears multiple times throughout this document when discussing the NFET between V_{REF1} and V_{REF2} . The value of V_{th} is approximately 0.6 V at room temperature.

8.1.2 Correct Device Set Up

In a normal set up shown in [Figure 8-1](#), the enable pin and V_{REF2} are shorted together and tied to a 200-k Ω resistor, and a reference voltage equal to V_{REF1} plus the FET threshold voltage is established. This reference voltage is used to help pass lows from one side to another more effectively while still separating the different pull up voltages on both sides.

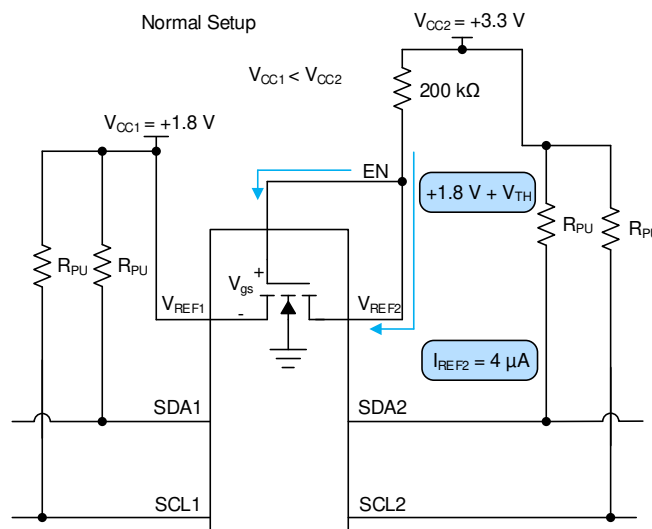

Figure 8-1. Normal Setup

Care should be taken to make sure V_{REF2} has an external resistor tied between it and V_{CC2} . If V_{REF2} is tied directly to the V_{CC2} rail without a resistor, then there is no external resistance from the V_{CC2} to V_{CC1} to limit the current such as in [Figure 8-2](#). This effectively looks like a low impedance path for current to travel through and

potentially break the pass FET if the current flowing through the pass FET is larger than the absolute maximum continuous channel current specified in the [Absolute Maximum Ratings](#). The continuous channel current is larger with a higher voltage difference between V_{CC1} and V_{CC2} .

Figure 8-2 shows an improper set up. If V_{CC2} is larger than V_{CC1} but less than V_{th} , the impedance between V_{CC1} and V_{CC2} is high resulting in a low drain to source current, which does not cause damage to the device. Concern arises when V_{CC2} becomes larger than V_{CC1} by V_{th} . During this event, the NFET turns on and begin to conduct current. This current is dependent on the gate to source voltage and drain to source voltage.

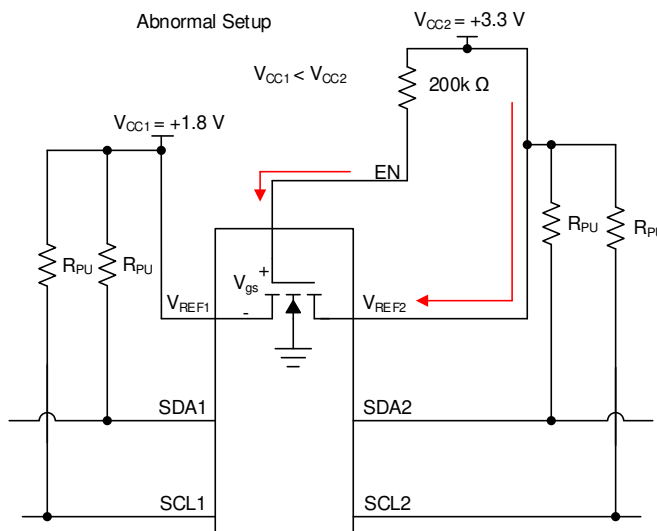

Figure 8-2. Abnormal Setup

8.1.3 Disconnecting a Responder from the Main Bus Using the EN Pin

TCA39306 can be used as a switch to disconnect one side of the device from the main bus, whether isolating I3C and I2C devices or different speed groups. This can be advantageous in multiple situations. One instance of this situation is if there are devices on the I2C bus which only supports fast mode (400 kHz) while other devices on the bus support fast mode plus (1 MHz). An example of this is displayed in [Figure 8-3](#).

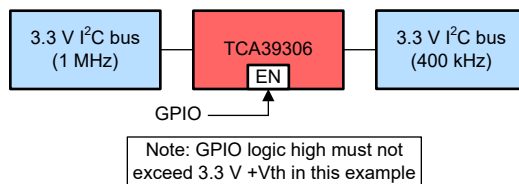

Figure 8-3. Example of an I2C bus with multiple supported frequencies

In this situation, if the controller is on the 1 MHz side then communicating at 1 MHz should not be attempted if TCA39306 were enabled. It needs to be disabled for the device to avoid possibly glitching state machines in devices which were designed to operate correctly at 400 kHz or slower. When the device is disabled, the controller can communicate with the 1 MHz devices without disturbing the 400 kHz bus. When the device is enabled, communication across both sides at 400 kHz is acceptable.

8.1.4 Supporting Remote Board Insertion to Backplane with TCA39306

Another situation where TCA39306 is advantageous when using its enable feature is when a remote board with I2C lines needs to be attached to a main board (backplane) with an I2C bus such as in [Figure 8-4](#). If connecting a remote board to a backplane is not done properly, the connection could result in data corruption during a transaction or the insertion could generate an unintended pulse on the SCL line. Which could glitch an I2C device state machine causing the I2C bus to get stuck.

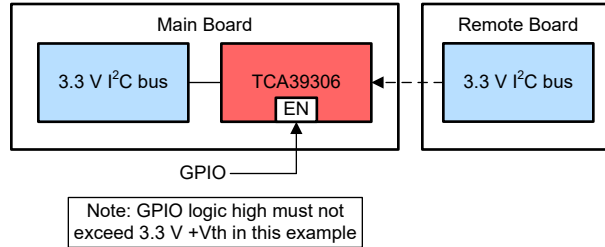

Figure 8-4. An example of connecting a remote board to a main board (backplane)

TCA39306 can be used to support this application because it can be disabled while making the connection. Then it is enabled once the remote board is powered on and the buses on both sides are IDLE.

8.1.5 Switch Configuration

TCA39306 has the capability of being used with its V_{REF1} voltage equal to V_{REF2} . This essentially turns the device from a translator to a device which can be used as a switch, and in some situations this can be useful. The switch configuration is shown in [Figure 8-5](#) and translation mode is shown in [Figure 8-6](#).

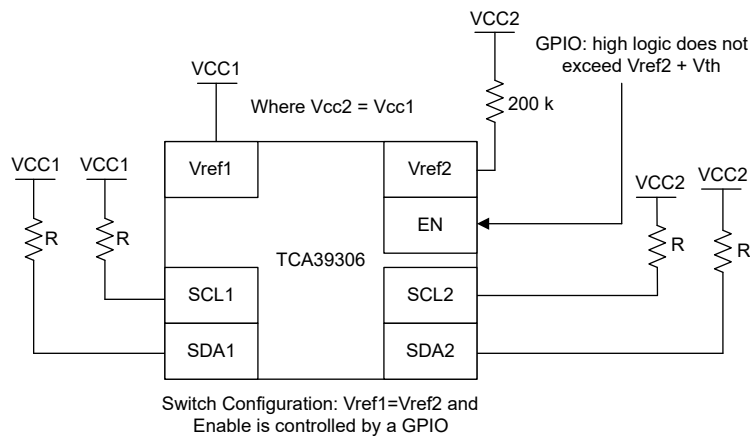

Figure 8-5. Switch Configuration

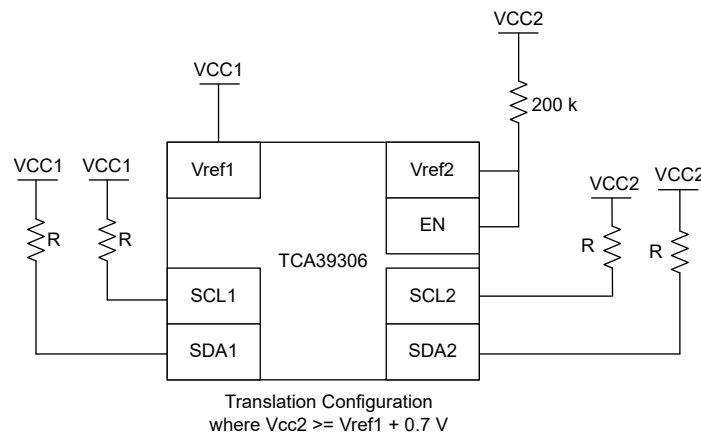

Figure 8-6. Translation Configuration

When TCA39306 is in the switch configuration ($V_{REF1} = V_{REF2}$), the propagation delays are different compared to the translator configuration. Taking a look at the propagation delays, if the pull up resistance and capacitance on both sides of the bus are equal, then in switch mode the device has the same propagation delay from side one to two and side two to one. The propagation delays become lower when V_{CC1}/V_{CC2} is larger. For example, the propagation delay at 1.8 V is longer than at 5 V in the switching configuration. When the device is in

translation mode, side one propagate lows to side two faster than side two can propagate lows to side 1. This time difference becomes larger the larger the difference between V_{CC2} and V_{CC1} becomes.

8.1.6 Controller on Side 1 or Side 2 of Device

I2C and SMBus are bidirectional protocol meaning devices on the bus can both transmit and receive data. TCA39306 was designed to allow for signals to be able to be transmitted from either side, thus allowing for the controller to be able to place on either side of the device. Figure 8-7 shows the controller on side two as opposed to the diagram on page 1 of this data sheet.

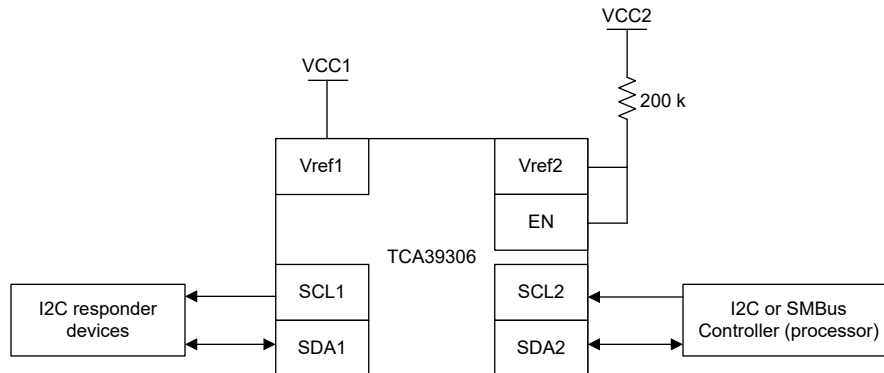

Figure 8-7. Controller on side 2

8.1.7 LDO and TCA39306 Concerns

The V_{REF1} pin can be supplied by a low-dropout regulator (LDO), but in some cases the LDO may lose its regulation because of the bias current from V_{REF2} to V_{REF1} . If the LDO cannot sink the bias current, then the current has no other paths to ground and instead charges up the capacitance on the V_{REF1} node (both external and parasitic). This results in an increase in voltage on the V_{REF1} node. If no other paths for current to flow are established (such as back biasing of body diodes or clamping diodes through other devices on the V_{REF1} node), then the V_{REF1} voltage ends up stabilizing when V_{gs} of the pass FET is equal to V_{th} . This means V_{REF1} node voltage is $V_{CC2} - V_{th}$. Note that any secondary or primaries running off of the LDO now see the $V_{CC2} - V_{th}$ voltage which may cause damage to those secondary or primaries if they are not rated to handle the increased voltage.

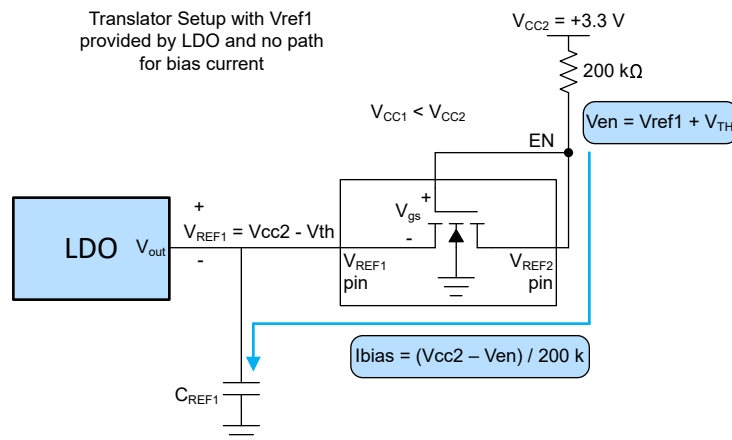

Figure 8-8. Example of no leakage current path when using LDO

To make sure the LDO does not lose regulation due to the bias current of TCA39306, a weak pull down resistor can be placed on V_{REF1} to ground to provide a path for the bias current to travel. The recommended pull down resistor is calculated by Equation 4 where 0.75 gives about 25% margin for error incase bias current increases during operation.

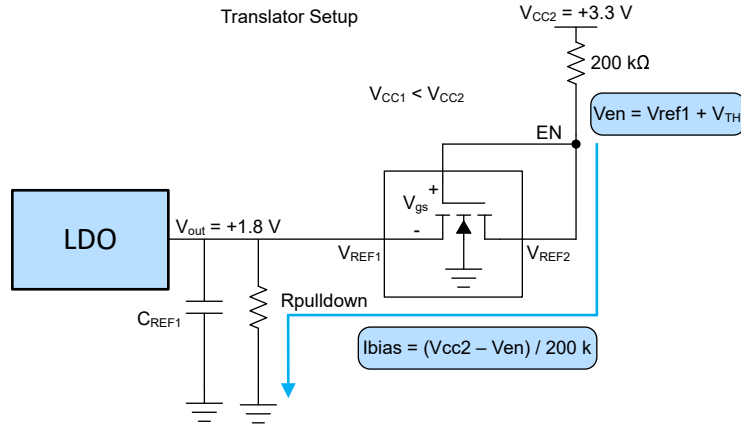

Figure 8-9. Example with Leakage current path when using an LDO

$$V_{en} = V_{REF1} + V_{th} \quad (1)$$

where

- V_{th} is approximately 0.6 V

$$I_{bias} = (V_{CC2} - V_{en}) / 200 \text{ k} \quad (2)$$

$$R_{pulldown} = V_{OUT} / I_{bias} \quad (3)$$

$$\text{Recommended } R_{pulldown} = R_{pulldown} \times 0.75 \quad (4)$$

8.1.8 Current Limiting Resistance on V_{REF2}

The resistor is used to limit the current between V_{REF2} and V_{REF1} (denoted as R_{CC}) and helps to establish the reference voltage on the enable pin. The 200k resistor can be changed to a lower value; however, the bias current proportionally increases as the resistor decreases.

$$I_{bias} = (V_{CC2} - V_{en}) / R_{CC} : V_{en} = V_{REF1} + V_{th} \quad (5)$$

where

- V_{th} is approximately 0.6 V

Keep in mind R_{CC} should not be sized low enough that I_{CC} exceeds the absolute maximum continuous channel current specified in the *Absolute Maximum Ratings* which is described in [Equation 6](#).

$$R_{CC}(\text{min}) \geq (V_{CC2} - V_{en}) / 0.128 : V_{en} = V_{REF1} + V_{th} \quad (6)$$

where

- V_{th} is approximately 0.6 V

8.2 Functional Block Diagram

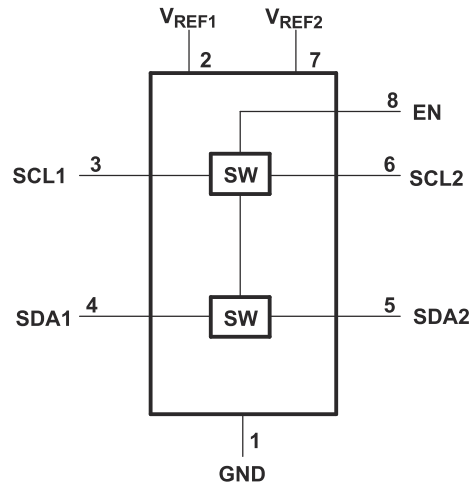

8.3 Feature Description

8.3.1 Enable (EN) Pin

The device is a double-pole, single-throw switch in which the gate of the transistors is controlled by the voltage on the EN pin. In [Figure 9-1](#), the device is always enabled when power is applied to V_{REF2} . In [Figure 9-2](#), the device is enabled when a control signal from a processor is in a logic-high state.

8.3.2 Voltage Translation

The primary feature of the device is translating voltage from an I²C bus referenced to V_{REF1} up to an I²C bus referenced to V_{DPU} , to which V_{REF2} is connected through a 200-k Ω pullup resistor. Translation on a standard, open-drain I²C bus is achieved by simply connecting pullup resistors from SCL1 and SDA1 to V_{REF1} and connecting pullup resistors from SCL2 and SDA2 to V_{DPU} . Information on sizing the pullup resistors can be found in the [Sizing Pullup Resistors](#) section.

8.4 Device Functional Modes

INPUT EN ⁽¹⁾	TRANSLATOR FUNCTION
H	Logic Lows are propagated from one side to the other, Logic Highs blocked (independent pull up resistors passively drive the line high)
L	Disconnect

(1) The SCL switch conducts if EN is ≥ 0.6 V higher than SCL1 or SCL2. The same is true of SDA.

9 Application and Implementation

Note

Information in the following applications sections is not part of the TI component specification, and TI does not warrant its accuracy or completeness. TI's customers are responsible for determining suitability of components for their purposes, as well as validating and testing their design implementation to confirm system functionality.

9.1 Application Information

9.1.1 General Applications of I²C

As with the standard I²C system, pullup resistors are required to provide the logic-high levels on the translator bus. The size of these pullup resistors depends on the system, but each side of the repeater must have a pullup resistor. The device is designed to work with standard-mode and fast-mode I²C devices in addition to SMBus devices. Standard-mode I²C devices only specify 3 mA in a generic I²C system where standard-mode devices and multiple controllers are possible. Under certain conditions, high termination currents can be used. When the SDA1 or SDA2 port is low, the clamp is in the ON state, and a low-resistance connection exists between the SDA1 and SDA2 ports. Assuming the higher voltage is on the SDA2 port when the SDA2 port is high, the voltage on the SDA1 port is limited to the voltage set by V_{REF1} . When the SDA1 port is high, the SDA2 port is pulled to the pullup supply voltage of the drain (V_{DPU}) by the pullup resistors. This functionality allows a seamless translation between higher and lower voltages selected by the user, without the need for directional control. The SCL1-SCL2 channel also functions in the same way as the SDA1-SDA2 channel.

9.2 Typical Application

Figure 9-1 and Figure 9-2 show how these pullup resistors are connected in a typical application, as well as two options for connecting the EN pin.

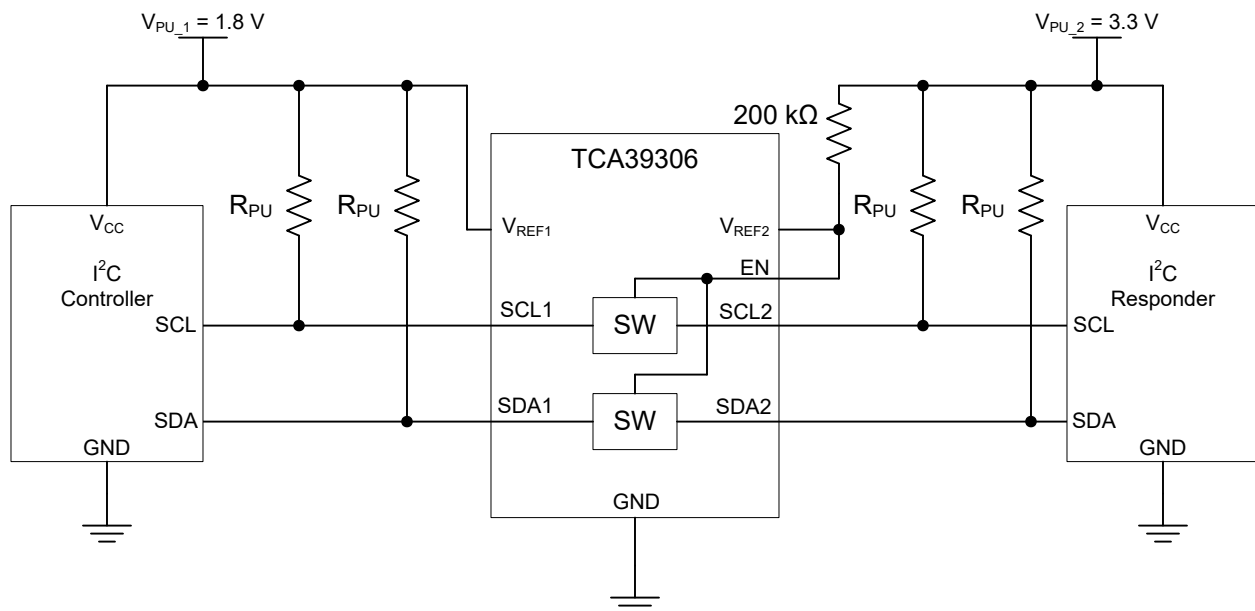

Figure 9-1. Typical Application Circuit (Switch Always Enabled)

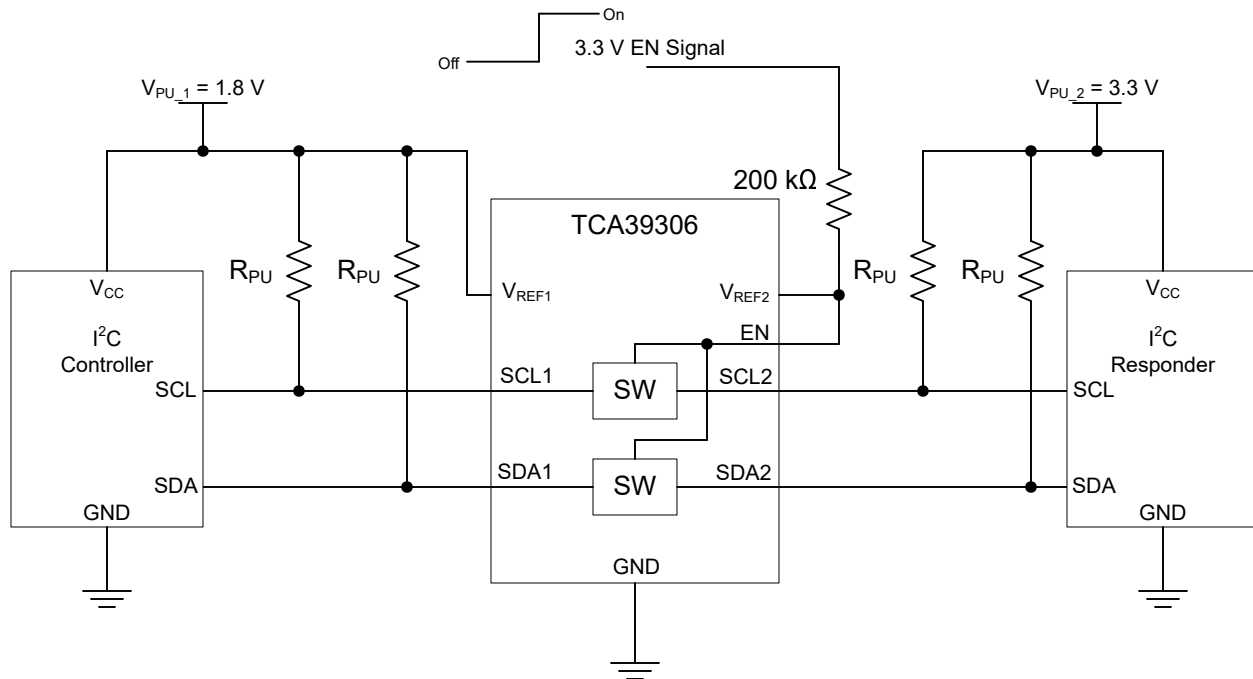

Figure 9-2. Typical Application Circuit (Switch Enable Control)

9.2.1 Design Requirements

		MIN	TYP ⁽¹⁾	MAX	UNIT
V_{REF2}	Reference voltage	$V_{REF1} + 0.6$	2.1	5	V
EN	Enable input voltage	$V_{REF1} + 0.6$	2.1	5	V
V_{REF1}	Reference voltage	0.9	1.5	4.4	V
I_{PASS}	Pass switch current		6		mA
I_{REF}	Reference-transistor current		5		μ A

(1) All typical values are at $T_A = 25^\circ\text{C}$.

9.2.2 Detailed Design Procedure

9.2.2.1 Bidirectional Voltage Translation

For the bidirectional clamping configuration (higher voltage to lower voltage or lower voltage to higher voltage), the EN input must be connected to V_{REF2} and both pins pulled to high-side V_{DPU} through a pullup resistor (typically 200 k Ω). This allows V_{REF2} to regulate the EN input. A 100-pF filter capacitor connected to V_{REF2} is recommended. The I²C bus controller output can be push-pull or open-drain (pullup resistors may be required) and the I²C bus device output can be open-drain (pullup resistors are required to pull the SCL2 and SDA2 outputs to V_{DPU}). However, if either output is push-pull, data must be unidirectional or the outputs must be 3-state capable and be controlled by some direction-control mechanism to prevent high-to-low contentions in either direction. If both outputs are open-drain, no direction control is needed.

9.2.2.2 Sizing Pullup Resistors

To get an estimate for the range of values that can be used for the pullup resistor, please refer to the application note [SLVA689](#). [Figure 9-3](#) and [Figure 9-4](#) respectively show the maximum and minimum pullup resistance allowable by the I²C specification for standard-mode (100 kHz) and fast-mode (400 kHz) operation.

9.2.2.3 Bandwidth

The maximum frequency of the device depends on the application. The device can operate at speeds of > 100 MHz given the correct conditions. The maximum frequency is dependent upon the loading of the application.

However, this is an analog type of measurement. For digital applications, the signal should not degrade up to the fifth harmonic of the digital signal. The frequency bandwidth should be at least five times the maximum digital clock rate. This component of the signal is important in determining the overall shape of the digital signal. In the case of the device, digital clock frequency of >100 MHz can be achieved.

The device does not provide any drive capability like the TCA9517 or other buffered translators. Therefore, higher-frequency applications require higher drive strength from the host side. No pullup resistor is needed on the host side (3.3 V) if the device is being driven by standard CMOS push-pull output driver. Ideally, it is best to minimize the trace length from device on the sink side (1.8 V) to minimize signal degradation.

You can then use a simple formula to compute the maximum *practical* frequency component or the *knee* frequency (f_{knee}). All fast edges have an infinite spectrum of frequency components. However, there is an inflection (or *knee*) in the frequency spectrum of fast edges where frequency components higher than f_{knee} are insignificant in determining the shape of the signal.

To calculate f_{knee} :

$$f_{knee} = 0.5 / RT \text{ (10\%–90\%)} \tag{7}$$

$$f_{knee} = 0.4 / RT \text{ (20\%–80\%)} \tag{8}$$

For signals with rise-time characteristics based on 10- to 90-percent thresholds, f_{knee} is equal to 0.5 divided by the rise time of the signal. For signals with rise-time characteristics based on 20- to 80-percent thresholds, which is very common in many current device specifications, f_{knee} is equal to 0.4 divided by the rise time of the signal.

Some guidelines to follow that help maximize the performance of the device:

- Keep trace length to a minimum by placing the device close to the I²C output of the processor.
- The trace length should be less than half the time of flight to reduce ringing and line reflections or non-monotonic behavior in the switching region.
- To reduce overshoots, a pullup resistor can be added on the 1.8 V side; be aware that a slower fall time is to be expected.

9.2.3 Application Curve

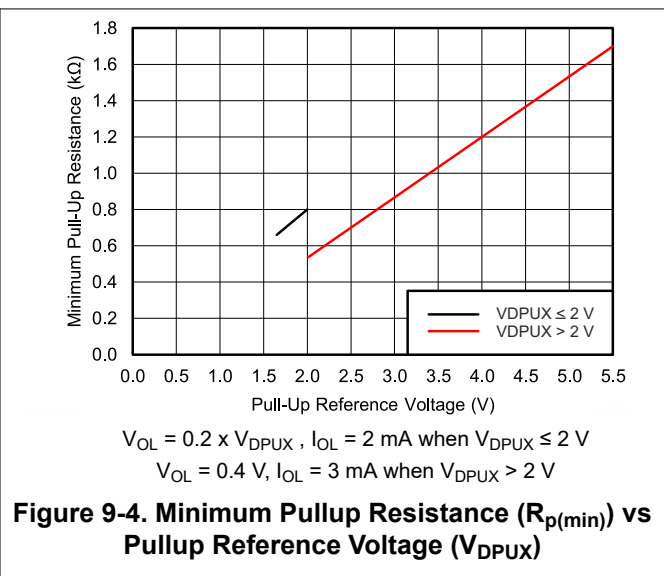
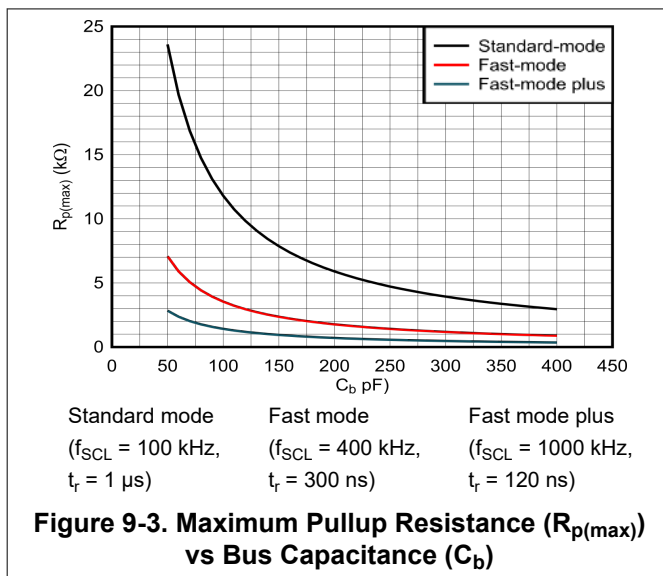

9.3 Systems Examples: I3C Usage Considerations

The TCA39306 has bandwidth to support the high speeds needed for I3C, but there are special considerations which are required. Since I3C uses both push-pull and open-drain, it may not be possible to support all I3C applications with a FET-based translator.

9.3.1 I3C Bus Switching

Bus switching is when the bus path is enabled or disabled, but does not translate the bus voltage. External pull-up resistors are not needed for I3C, because the controller enables or disables the pull-up resistor on the SDA line. This presents a unique challenge for FET-based translators, like the TCA39306, because they rely on a pull-up resistor to pull the output side of the switch all the way to supply. For the switching use case, there is no translation, but the enable voltage must be high enough for the switch to stay on for the entire voltage range of the bus (0 V to bus voltage).

R_{ON} must be low enough for the full push-pull voltage range. The EN voltage must be at least $1 V_t$ (~ 0.6 V) above the maximum desired pass-voltage. This comes out to $V_{EN} \geq V_{BUS} + 0.6$ V. Since the switch enable voltage is being directly controlled, the V_{REF1} and V_{REF2} pins are not needed, and can be shorted to ground to improve power consumption.

It is possible to control the EN pin with a voltage equal to V_{BUS} , but external pull-up resistors on the downstream side are a requirement to ensure the bus is pulled entirely to V_{BUS} .

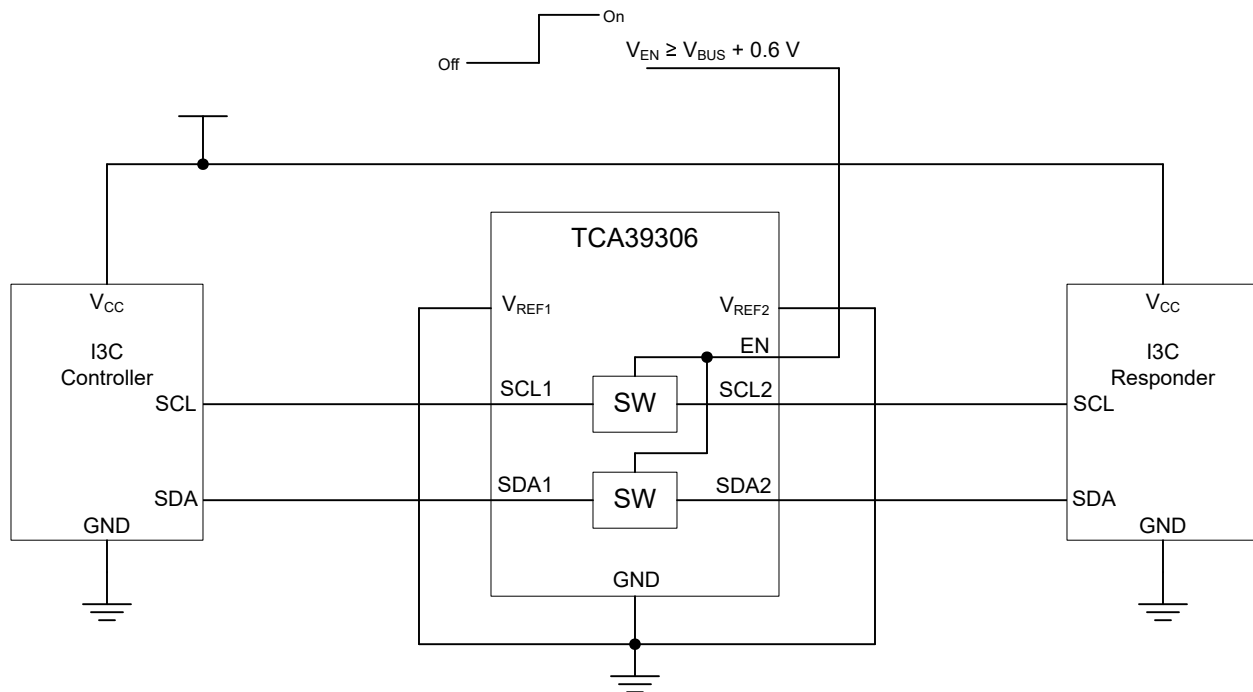

Figure 9-5. I3C Bus Switching Application (Without Pull-up Resistors)

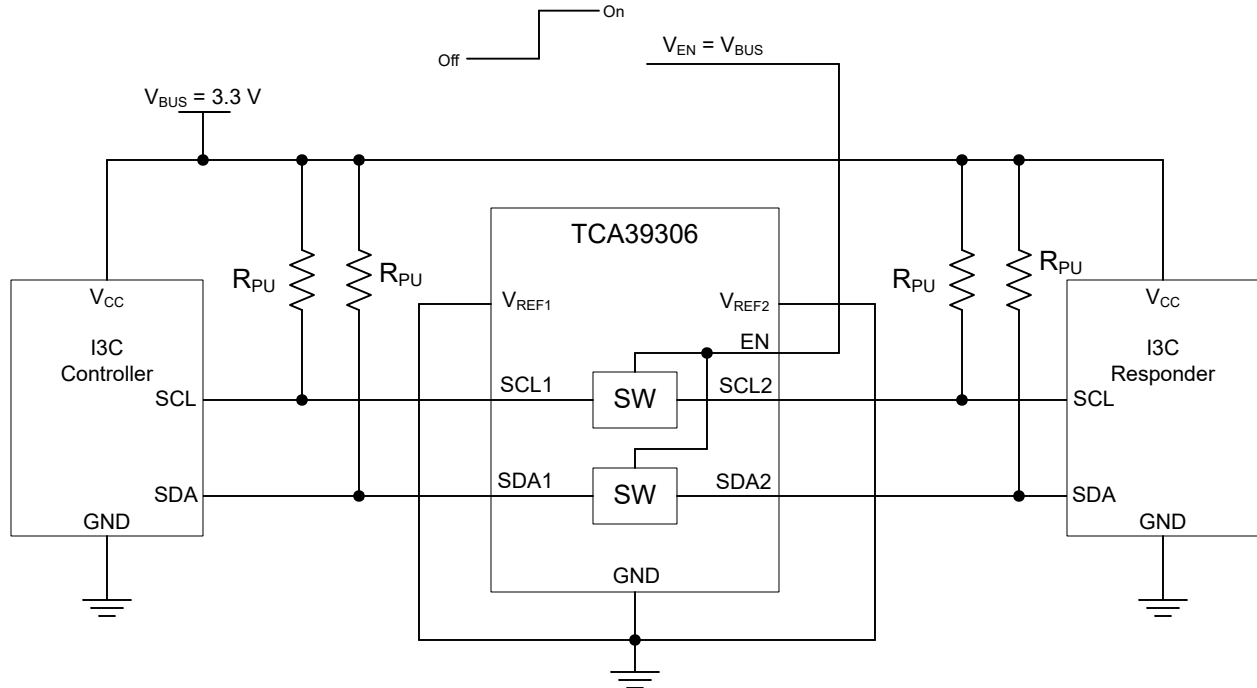

Figure 9-6. I3C Bus Switching Application (With Pull-up Resistors)

9.3.2 I3C Bus Voltage Translation

Bus voltage translation is when the bus voltage is translated up or down. This presents a unique challenge with I3C for FET-based translators, like the TCA39306, because they rely on a pull-up resistor to translate the voltage up from the low-voltage side. The pull-up resistor selected must be strong enough to meet the timing requirements (based on bus capacitance and translation voltages), but not so strong to violate the V_{IL} requirements of the I3C devices.

The pull-up resistors are needed on both sides. The reason for this is that with the normal translation setup, the switch is "on" when either side's bus voltage drops to roughly V_{PU_1} . This means that the pull-up resistors are required to pull the bus voltage on the high-voltage side from V_{PU_1} to V_{PU_2} . When the device on the high-voltage side is controlling the bus, the switch will turn off at V_{PU_1} . The pull-up resistors on the low-voltage side are used to bleed off any additional current that might "leak" through the switch.

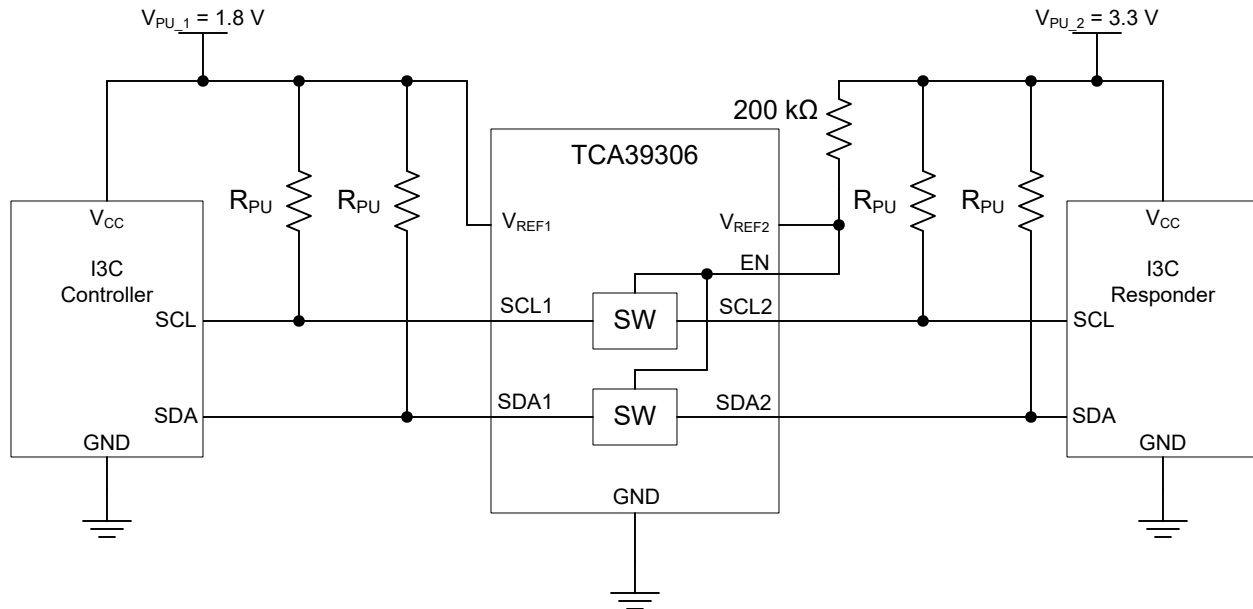

Figure 9-7. I3C Bus Translation

9.4 Power Supply Recommendations

For supplying power to the device, the V_{REF1} pin can be connected directly to a power supply. The V_{REF2} pin must be connected to the V_{DPU} power supply through a 200-k Ω resistor. Failure to have a high-impedance resistor between V_{REF2} and V_{DPU} results in excessive current draw and unreliable device operation. It is also worth noting, that in order to support voltage translation, the device must have the EN and V_{REF2} pins shorted and then pulled up to V_{DPU} through a high-impedance resistor.

9.5 Layout

9.5.1 Layout Guidelines

For printed-circuit board (PCB) layout of the device, common PCB layout practices should be followed, but additional concerns related to high-speed data transfer such as matched impedances and differential pairs are not a concern for I²C signal speeds.

In all PCB layouts, it is a best practice to avoid right angles in signal traces, to fan out signal traces away from each other on leaving the vicinity of an integrated circuit (IC), and to use thicker trace widths to carry higher amounts of current that commonly pass through power and ground traces. The 100-pF filter capacitor should be placed as close to V_{REF2} as possible. A larger decoupling capacitor can also be used, but a longer time constant of two capacitors and the 200-k Ω resistor results in longer turnon and turnoff times for the TCA39306 device. These best practices are shown in [Figure 9-8](#).

For the layout example provided in [Figure 9-8](#), it would be possible to fabricate a PCB with only two layers by using the top layer for signal routing and the bottom layer as a split plane for power (V_{CC}) and ground (GND). However, a four-layer board is preferable for boards with higher-density signal routing. On a four-layer PCB, it is common to route signals on the top and bottom layer, dedicate one internal layer to a ground plane, and dedicate the other internal layer to a power plane. In a board layout using planes or split planes for power and ground, vias are placed directly next to the surface-mount component pad, which must attach to V_{CC} or GND, and the via is connected electrically to the internal layer or the other side of the board. Vias are also used when a signal trace must be routed to the opposite side of the board, but this technique is not demonstrated in [Figure 9-8](#).

9.5.2 Layout Example

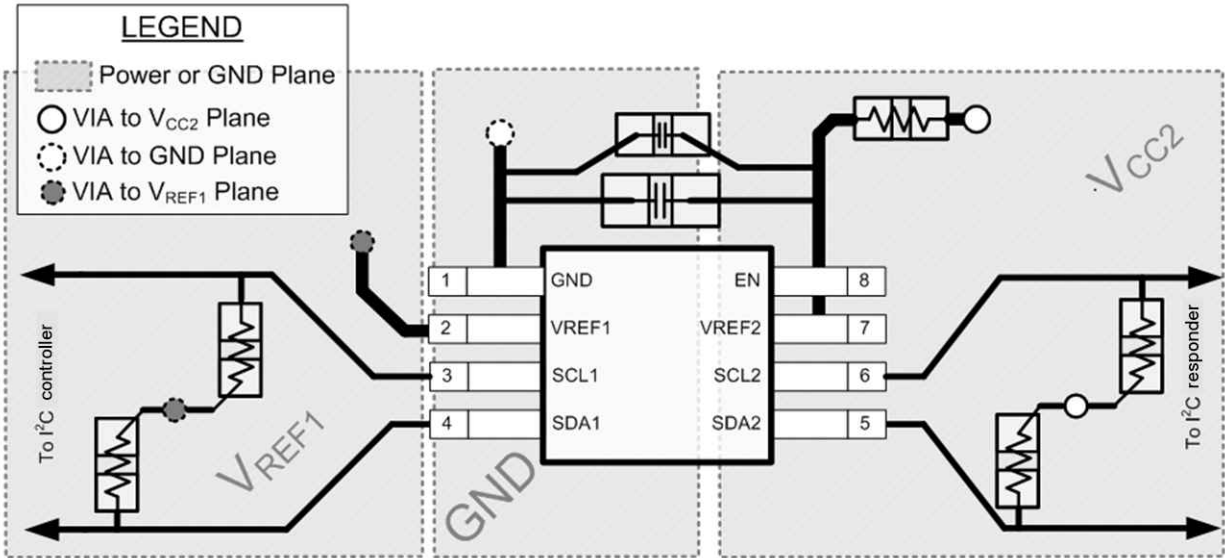

Figure 9-8. Layout Example

10 Device and Documentation Support

10.1 Receiving Notification of Documentation Updates

To receive notification of documentation updates, navigate to the device product folder on ti.com. In the upper right corner, click on *Alert me* to register and receive a weekly digest of any product information that has changed. For change details, review the revision history included in any revised document.

10.2 Support Resources

TI E2E™ [support forums](#) are an engineer's go-to source for fast, verified answers and design help — straight from the experts. Search existing answers or ask your own question to get the quick design help you need.

Linked content is provided "AS IS" by the respective contributors. They do not constitute TI specifications and do not necessarily reflect TI's views; see TI's [Terms of Use](#).

10.3 Trademarks

TI E2E™ is a trademark of Texas Instruments.

All trademarks are the property of their respective owners.

10.4 Electrostatic Discharge Caution



This integrated circuit can be damaged by ESD. Texas Instruments recommends that all integrated circuits be handled with appropriate precautions. Failure to observe proper handling and installation procedures can cause damage.

ESD damage can range from subtle performance degradation to complete device failure. Precision integrated circuits may be more susceptible to damage because very small parametric changes could cause the device not to meet its published specifications.

10.5 Glossary

[TI Glossary](#) This glossary lists and explains terms, acronyms, and definitions.

11 Mechanical, Packaging, and Orderable Information

The following pages include mechanical, packaging, and orderable information. This information is the most-current data available for the designated device. This data is subject to change without notice and without revision of this document. For browser-based versions of this data sheet, see the left-hand navigation pane.

PACKAGING INFORMATION

Orderable part number	Status (1)	Material type (2)	Package Pins	Package qty Carrier	RoHS (3)	Lead finish/ Ball material (4)	MSL rating/ Peak reflow (5)	Op temp (°C)	Part marking (6)
TCA39306DCUR	Active	Production	VSSOP (DCU) 8	3000 LARGE T&R	Yes	NIPDAUAG SN	Level-1-260C-UNLIM	-40 to 125	(2GPT, 2GVI)
TCA39306DCUR.A	Active	Production	VSSOP (DCU) 8	3000 LARGE T&R	Yes	SN	Level-1-260C-UNLIM	-40 to 125	(2GPT, 2GVI)
TCA39306DDFR	Active	Production	SOT-23-THIN (DDF) 8	3000 LARGE T&R	Yes	SN	Level-1-260C-UNLIM	-40 to 125	2M9H
TCA39306DDFR.A	Active	Production	SOT-23-THIN (DDF) 8	3000 LARGE T&R	Yes	SN	Level-1-260C-UNLIM	-40 to 125	2M9H
TCA39306DTMR	Active	Production	X2SON (DTM) 8	5000 LARGE T&R	Yes	NIPDAUAG	Level-1-260C-UNLIM	-40 to 125	1IH
TCA39306DTMR.A	Active	Production	X2SON (DTM) 8	5000 LARGE T&R	Yes	NIPDAUAG	Level-1-260C-UNLIM	-40 to 125	1IH

(1) **Status:** For more details on status, see our [product life cycle](#).

(2) **Material type:** When designated, preproduction parts are prototypes/experimental devices, and are not yet approved or released for full production. Testing and final process, including without limitation quality assurance, reliability performance testing, and/or process qualification, may not yet be complete, and this item is subject to further changes or possible discontinuation. If available for ordering, purchases will be subject to an additional waiver at checkout, and are intended for early internal evaluation purposes only. These items are sold without warranties of any kind.

(3) **RoHS values:** Yes, No, RoHS Exempt. See the [TI RoHS Statement](#) for additional information and value definition.

(4) **Lead finish/Ball material:** Parts may have multiple material finish options. Finish options are separated by a vertical ruled line. Lead finish/Ball material values may wrap to two lines if the finish value exceeds the maximum column width.

(5) **MSL rating/Peak reflow:** The moisture sensitivity level ratings and peak solder (reflow) temperatures. In the event that a part has multiple moisture sensitivity ratings, only the lowest level per JEDEC standards is shown. Refer to the shipping label for the actual reflow temperature that will be used to mount the part to the printed circuit board.

(6) **Part marking:** There may be an additional marking, which relates to the logo, the lot trace code information, or the environmental category of the part.

Multiple part markings will be inside parentheses. Only one part marking contained in parentheses and separated by a "~" will appear on a part. If a line is indented then it is a continuation of the previous line and the two combined represent the entire part marking for that device.

Important Information and Disclaimer: The information provided on this page represents TI's knowledge and belief as of the date that it is provided. TI bases its knowledge and belief on information provided by third parties, and makes no representation or warranty as to the accuracy of such information. Efforts are underway to better integrate information from third parties. TI has taken and continues to take reasonable steps to provide representative and accurate information but may not have conducted destructive testing or chemical analysis on incoming materials and chemicals. TI and TI suppliers consider certain information to be proprietary, and thus CAS numbers and other limited information may not be available for release.

In no event shall TI's liability arising out of such information exceed the total purchase price of the TI part(s) at issue in this document sold by TI to Customer on an annual basis.

OTHER QUALIFIED VERSIONS OF TCA39306 :

- Automotive : [TCA39306-Q1](#)

NOTE: Qualified Version Definitions:

- Automotive - Q100 devices qualified for high-reliability automotive applications targeting zero defects

TAPE AND REEL INFORMATION

QUADRANT ASSIGNMENTS FOR PIN 1 ORIENTATION IN TAPE

*All dimensions are nominal

Device	Package Type	Package Drawing	Pins	SPQ	Reel Diameter (mm)	Reel Width W1 (mm)	A0 (mm)	B0 (mm)	K0 (mm)	P1 (mm)	W (mm)	Pin1 Quadrant
TCA39306DCUR	VSSOP	DCU	8	3000	178.0	9.0	2.25	3.35	1.05	4.0	8.0	Q3
TCA39306DTMR	X2SON	DTM	8	5000	178.0	8.4	0.93	1.49	0.43	2.0	8.0	Q1

TAPE AND REEL BOX DIMENSIONS

*All dimensions are nominal

Device	Package Type	Package Drawing	Pins	SPQ	Length (mm)	Width (mm)	Height (mm)
TCA39306DCUR	VSSOP	DCU	8	3000	180.0	180.0	18.0
TCA39306DTMR	X2SON	DTM	8	5000	205.0	200.0	33.0

DCU0008A

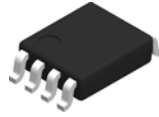

PACKAGE OUTLINE

VSSOP - 0.9 mm max height

SMALL OUTLINE PACKAGE



4225266/A 09/2014

NOTES:

1. All linear dimensions are in millimeters. Any dimensions in parenthesis are for reference only. Dimensioning and tolerancing per ASME Y14.5M.
2. This drawing is subject to change without notice.
3. This dimension does not include mold flash, protrusions, or gate burrs. Mold flash, protrusions, or gate burrs shall not exceed 0.15 mm per side.
4. Reference JEDEC registration MO-187 variation CA.

EXAMPLE BOARD LAYOUT

DCU0008A

VSSOP - 0.9 mm max height

SMALL OUTLINE PACKAGE



LAND PATTERN EXAMPLE
EXPOSED METAL SHOWN
SCALE: 25X



4225266/A 09/2014

NOTES: (continued)

- 5. Publication IPC-7351 may have alternate designs.
- 6. Solder mask tolerances between and around signal pads can vary based on board fabrication site.

EXAMPLE STENCIL DESIGN

DCU0008A

VSSOP - 0.9 mm max height

SMALL OUTLINE PACKAGE



SOLDER PASTE EXAMPLE
BASED ON 0.125 mm THICK STENCIL
SCALE: 25X

4225266/A 09/2014

NOTES: (continued)

7. Laser cutting apertures with trapezoidal walls and rounded corners may offer better paste release. IPC-7525 may have alternate design recommendations.
8. Board assembly site may have different recommendations for stencil design.

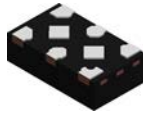

DTM0008A

PACKAGE OUTLINE

X2SON - 0.4 mm max height

PLASTIC SMALL OUTLINE - NO LEAD

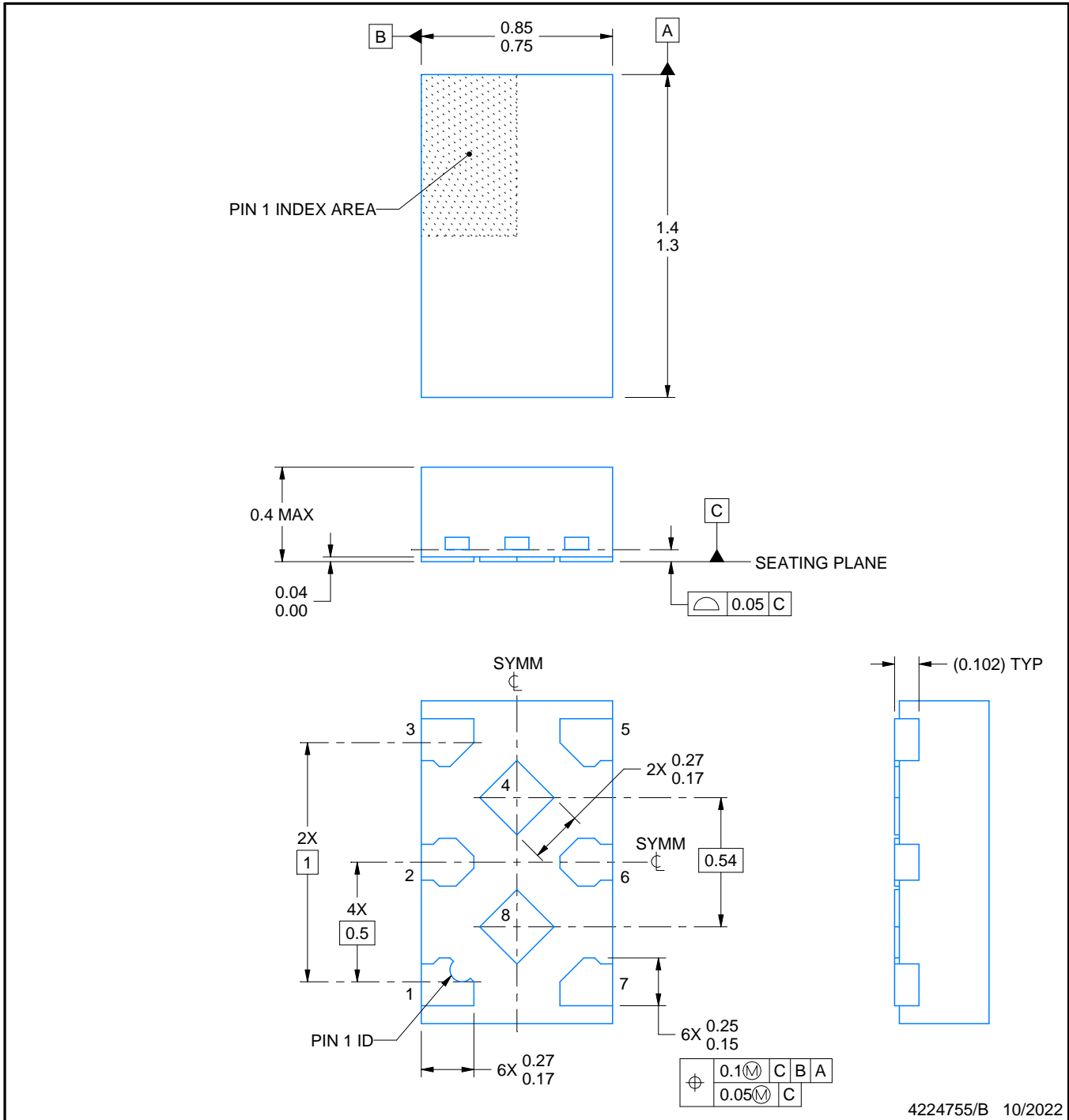

NOTES:

1. All linear dimensions are in millimeters. Any dimensions in parenthesis are for reference only. Dimensioning and tolerancing per ASME Y14.5M.
2. This drawing is subject to change without notice.
3. The package thermal pad(s) must be soldered to the printed circuit board for thermal and mechanical performance.

EXAMPLE BOARD LAYOUT

DTM0008A

X2SON - 0.4 mm max height

PLASTIC SMALL OUTLINE - NO LEAD

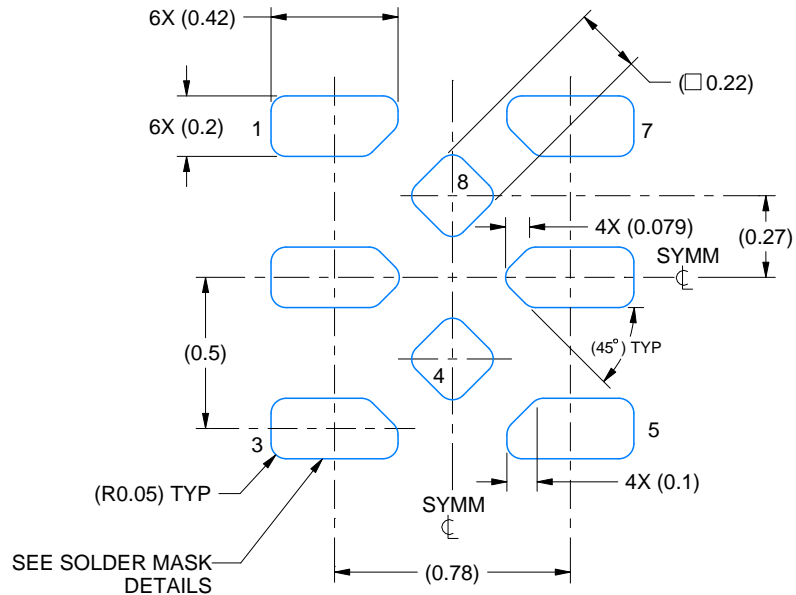

LAND PATTERN EXAMPLE
EXPOSED METAL SHOWN
SCALE:40X

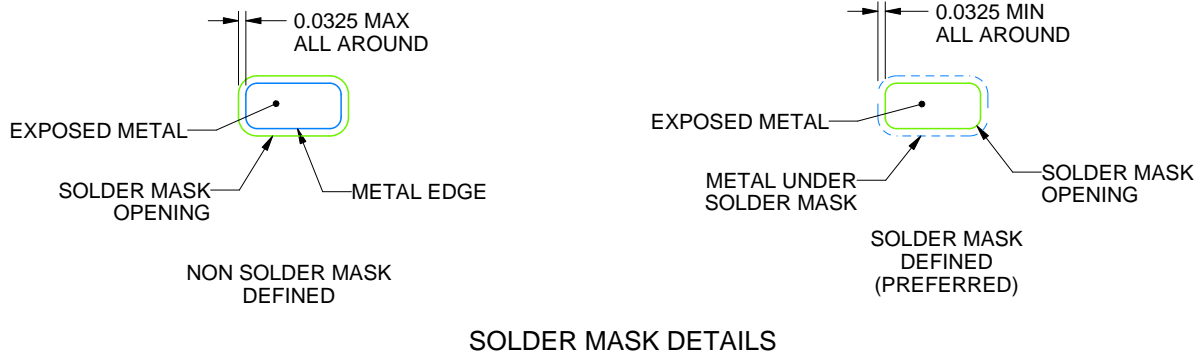

4224755/B 10/2022

NOTES: (continued)

- This package is designed to be soldered to a thermal pad on the board. For more information, see Texas Instruments literature number SLUA271 (www.ti.com/lit/slua271).

EXAMPLE STENCIL DESIGN

DTM0008A

X2SON - 0.4 mm max height

PLASTIC SMALL OUTLINE - NO LEAD

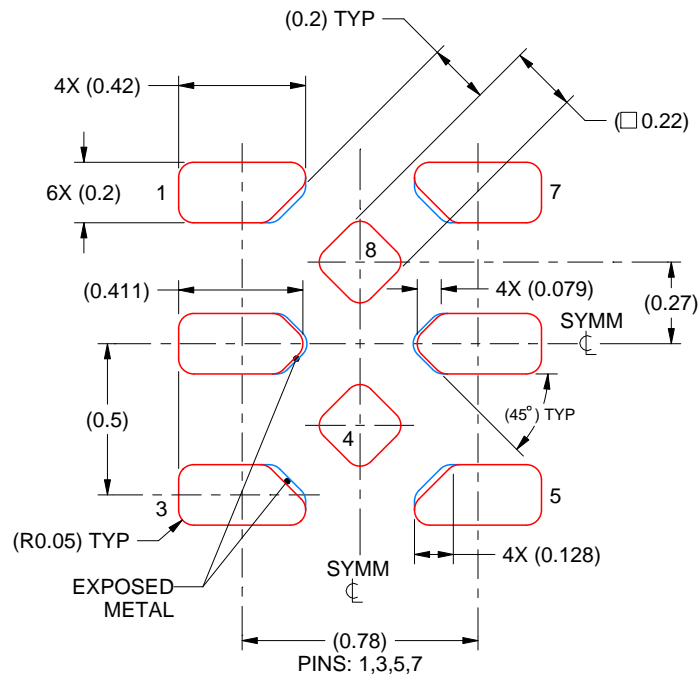

SOLDER PASTE EXAMPLE
BASED ON 0.075 mm THICK STENCIL
SCALE: 40X

4224755/B 10/2022

5. Laser cutting apertures with trapezoidal walls and rounded corners may offer better paste release. IPC-7525 may have alternate design recommendations.

DDF0008A



PACKAGE OUTLINE

SOT-23-THIN - 1.1 mm max height

PLASTIC SMALL OUTLINE



4222047/E 07/2024

NOTES:

1. All linear dimensions are in millimeters. Any dimensions in parenthesis are for reference only. Dimensioning and tolerancing per ASME Y14.5M.
2. This drawing is subject to change without notice.
3. This dimension does not include mold flash, protrusions, or gate burrs. Mold flash, protrusions, or gate burrs shall not exceed 0.15 mm per side.

EXAMPLE BOARD LAYOUT

DDF0008A

SOT-23-THIN - 1.1 mm max height

PLASTIC SMALL OUTLINE



LAND PATTERN EXAMPLE
EXPOSED METAL SHOWN
SCALE:15X



SOLDER MASK DETAILS

4222047/E 07/2024

NOTES: (continued)

- 4. Publication IPC-7351 may have alternate designs.
- 5. Solder mask tolerances between and around signal pads can vary based on board fabrication site.

EXAMPLE STENCIL DESIGN

DDF0008A

SOT-23-THIN - 1.1 mm max height

PLASTIC SMALL OUTLINE



SOLDER PASTE EXAMPLE
BASED ON 0.125 mm THICK STENCIL
SCALE:15X

4222047/E 07/2024

NOTES: (continued)

6. Laser cutting apertures with trapezoidal walls and rounded corners may offer better paste release. IPC-7525 may have alternate design recommendations.
7. Board assembly site may have different recommendations for stencil design.

IMPORTANT NOTICE AND DISCLAIMER

TI PROVIDES TECHNICAL AND RELIABILITY DATA (INCLUDING DATA SHEETS), DESIGN RESOURCES (INCLUDING REFERENCE DESIGNS), APPLICATION OR OTHER DESIGN ADVICE, WEB TOOLS, SAFETY INFORMATION, AND OTHER RESOURCES "AS IS" AND WITH ALL FAULTS, AND DISCLAIMS ALL WARRANTIES, EXPRESS AND IMPLIED, INCLUDING WITHOUT LIMITATION ANY IMPLIED WARRANTIES OF MERCHANTABILITY, FITNESS FOR A PARTICULAR PURPOSE OR NON-INFRINGEMENT OF THIRD PARTY INTELLECTUAL PROPERTY RIGHTS.

These resources are intended for skilled developers designing with TI products. You are solely responsible for (1) selecting the appropriate TI products for your application, (2) designing, validating and testing your application, and (3) ensuring your application meets applicable standards, and any other safety, security, regulatory or other requirements.

These resources are subject to change without notice. TI grants you permission to use these resources only for development of an application that uses the TI products described in the resource. Other reproduction and display of these resources is prohibited. No license is granted to any other TI intellectual property right or to any third party intellectual property right. TI disclaims responsibility for, and you will fully indemnify TI and its representatives against, any claims, damages, costs, losses, and liabilities arising out of your use of these resources.

TI's products are provided subject to [TI's Terms of Sale](#) or other applicable terms available either on [ti.com](https://www.ti.com) or provided in conjunction with such TI products. TI's provision of these resources does not expand or otherwise alter TI's applicable warranties or warranty disclaimers for TI products.

TI objects to and rejects any additional or different terms you may have proposed.

Mailing Address: Texas Instruments, Post Office Box 655303, Dallas, Texas 75265

Copyright © 2025, Texas Instruments Incorporated