

SN74LV163A 4-Bit Synchronous Binary Counters

1 Features

- 2V to 5.5V V_{CC} operation
- Max t_{pd} of 9.5ns at 5V
- Typical V_{OLP} (output ground bounce) $<0.8V$ at $V_{CC} = 3.3V$, $T_A = 25^\circ C$
- Typical V_{OHV} (output V_{OH} undershoot) $>2.3V$ at $V_{CC} = 3.3V$, $T_A = 25^\circ C$
- Support mixed-mode voltage operation on all ports
- Internal look ahead for fast counting
- Carry output for n-bit cascading
- Synchronous counting
- Synchronously programmable
- I_{off} supports partial-power-down mode operation
- Latch-up performance exceeds 100mA per JESD 78, class II

2 Description

The 'LV163A devices are 4-bit synchronous binary counters designed for 2V to 5.5V V_{CC} operation.

Package Information

PART NUMBER	PACKAGE ⁽¹⁾	PACKAGE SIZE ⁽²⁾	BODY SIZE ⁽³⁾
SN74LV163A	D (SOIC, 16)	9.9mm × 6mm	9.90mm × 3.91mm
	DB (SSOP, 16)	6.2mm × 7.8mm	6.20mm × 5.30mm
	DGV (TVSOP, 16)	3.6mm × 6.4mm	5.00mm × 4.40mm
	NS (SOP, 16)	10.2mm × 7.8mm	10.20mm × 5.30mm
	PW (TSSOP, 16)	5.00mm × 6.4mm	5.00mm × 4.40mm
	RGY (VQFN, 16)	4mm × 3.5mm	4.00mm × 3.50mm

- (1) For more information, see [Mechanical, Packaging, and Orderable Information](#).
- (2) The package size (length × width) is a nominal value and includes pins, where applicable.
- (3) The body size (length × width) is a nominal value and does not include pins.

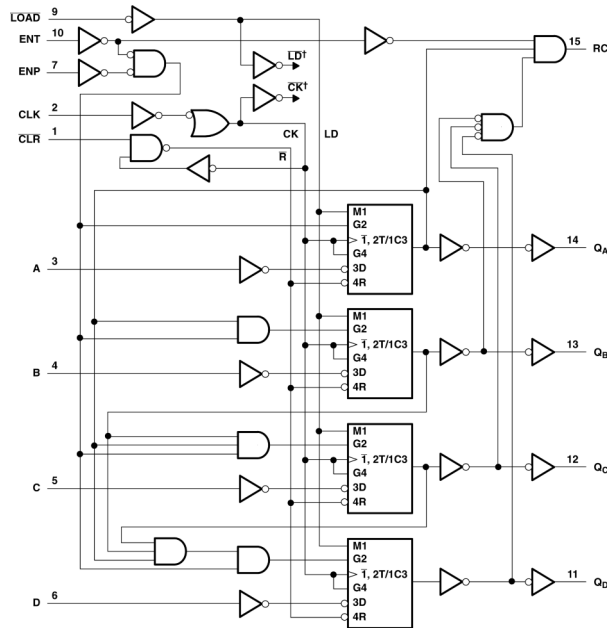

Logic Diagram (Positive Logic)



Table of Contents

1 Features	1	5 Parameter Measurement Information	9
2 Description	1	6 Detailed Description	11
3 Pin Configuration and Functions	3	6.1 Overview.....	11
4 Specifications	4	6.2 Functional Block Diagram.....	12
4.1 Absolute Maximum Ratings.....	4	6.3 Device Functional Modes.....	13
4.2 ESD Ratings.....	4	7 Application and Implementation	14
4.3 Recommended Operating Conditions.....	4	7.1 Power Supply Recommendations.....	14
4.4 Thermal Information.....	5	7.2 Layout.....	14
4.5 Electrical Characteristics.....	5	8 Device and Documentation Support	16
4.6 Timing Requirements, $V_{CC} = 2.5V \pm 0.2V$	5	8.1 Documentation Support.....	16
4.7 Timing Requirements, $V_{CC} = 3.3V \pm 0.3V$	6	8.2 Receiving Notification of Documentation Updates....	16
4.8 Timing Requirements, $V_{CC} = 5V \pm 0.5V$	6	8.3 Support Resources.....	16
4.9 Switching Characteristics, $V_{CC} = 2.5V \pm 0.2V$	6	8.4 Trademarks.....	16
4.10 Switching Characteristics, $V_{CC} = 3.3V \pm 0.3V$	7	8.5 Electrostatic Discharge Caution.....	16
4.11 Switching Characteristics, $V_{CC} = 5V \pm 0.5V$	7	8.6 Glossary.....	16
4.12 Noise Characteristics.....	7	9 Revision History	16
4.13 Operating Characteristics.....	8	10 Mechanical, Packaging, and Orderable Information	16
4.14 Typical Clear, Preset, Count, and Inhibit Sequence.....	8		

3 Pin Configuration and Functions

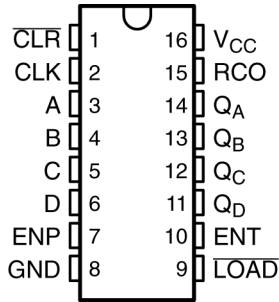

Figure 3-1. SN74LV163A D, DB, DGV, NS, or PW Package; 16-Pin SOIC, SSOP, TVSOP, SOP, or TSSOP (Top View)

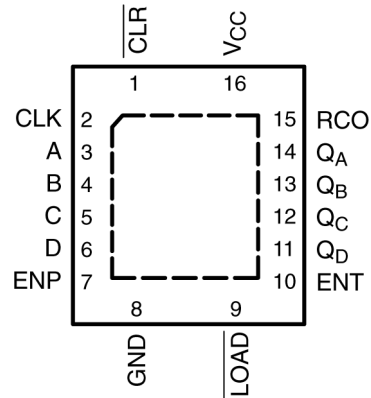

Figure 3-2. SN74LV163A RGY Package, 16-Pin VQFN (Top View)

Pin Functions

NAME	PIN	TYPE ¹	DESCRIPTION
CLR	1	I	Clear, active low
CLK	2	I	Clock, rising edge triggered
A	3	I	Load data A
B	4	I	Load data B
C	5	I	Load data C
D	6	I	Load data D
ENP	7	I	Count enable, does not affect RCO
GND	8	—	Ground
LOAD	9	I	Parallel load, active low
ENT	10	I	Count enable, affects RCO
Q _D	11	O	Q _D output
Q _C	12	O	Q _C output
Q _B	13	O	Q _B output
Q _A	14	O	Q _A output
RCO	15	O	Ripple-carry output
V _{CC}	16	—	Supply

1. I = input, O = output, P = power, FB = feedback, GND = ground, N/A = not applicable

4 Specifications

4.1 Absolute Maximum Ratings

over operating free-air temperature range (unless otherwise noted)⁽¹⁾

		MIN	MAX	UNIT
V _{CC}	Supply voltage range	-0.5	7	V
V _I ⁽²⁾	Input voltage range	-0.5	7	V
V _O ⁽²⁾	Output voltage range applied in high or low state	-0.5	V _{CC} + 0.5	V
V _O ⁽²⁾	Voltage range applied to any output in the power-off state	-0.5	7	V
I _{IK}	Input clamp current	(V _I < 0)	-20	mA
I _{OK}	Output clamp current	(V _O < 0)	-50	mA
I _O	Continuous output current	(V _O = 0 to V _{CC})	±25	mA
	Continuous current through V _{CC} or GND		±50	mA
T _{stg}	Storage temperature range	-65	150	°C

(1) Stresses beyond those listed under “absolute maximum ratings” may cause permanent damage to the device. These are stress ratings only, and functional operation of the device at these or any other conditions beyond those indicated under “recommended operating conditions” is not implied. Exposure to absolute-maximum-rated conditions for extended periods may affect device reliability.

(2) The input and output negative-voltage ratings may be exceeded if the input and output current ratings are observed.

4.2 ESD Ratings

		VALUE	UNIT
V _(ESD) Electrostatic discharge	Human body model (HBM), per ANSI/ESDA/JEDEC JS-001 ⁽¹⁾	±2000	V
	JEDEC document JEP157 states that 250V CDM allows safe manufacturing with a standard ESD control process. ⁽¹⁾	±1000	

(1) JEDEC document JEP155 states that 500-V HBM allows safe manufacturing with a standard ESD control process.

4.3 Recommended Operating Conditions

over operating free-air temperature range (unless otherwise noted)⁽¹⁾

		SN74LV163A		UNIT
		MIN	MAX	
V _{CC}	Supply voltage	2	5.5	V
V _{IH}	High-level input voltage	V _{CC} = 2 V	1.5	V
		V _{CC} = 2.3 V to 2.7 V	V _{CC} × 0.7	
		V _{CC} = 3 V to 3.6 V	V _{CC} × 0.7	
		V _{CC} = 4.5 V to 1.5 V	V _{CC} × 0.7	
V _{IL}	Low-level input voltage	V _{CC} = 2 V	0.5	V
		V _{CC} = 2.3 V to 2.7 V	V _{CC} × 0.3	
		V _{CC} = 3 V to 3.6 V	V _{CC} × 0.3	
		V _{CC} = 4.5 V to 1.5 V	V _{CC} × 0.3	
V _I	Input voltage	0	5.5	V
V _O	Output voltage	0	V _{CC}	V
I _{OH}	High-level output current	V _{CC} = 2 V	-50	μA
		V _{CC} = 2.3 V to 2.7 V	-2	mA
		V _{CC} = 3 V to 3.6 V	-6	
		V _{CC} = 4.5 V to 1.5 V	-12	
I _{OL}	Low-level output current	V _{CC} = 2 V	50	μA
		V _{CC} = 2.3 V to 2.7 V	2	mA
		V _{CC} = 3 V to 3.6 V	6	
		V _{CC} = 4.5 V to 1.5 V	12	

over operating free-air temperature range (unless otherwise noted)⁽¹⁾

			SN74LV163A		UNIT
			MIN	MAX	
$\Delta t/\Delta v$	Input transition rise or fall rate	$V_{CC} = 2.3 \text{ V to } 2.7 \text{ V}$	200		ns/V
		$V_{CC} = 3 \text{ V to } 3.6 \text{ V}$	100		
		$V_{CC} = 4.5 \text{ V to } 1.5 \text{ V}$	20		
T_A	Operating free-air temperature	-40	85		°C

(1) All unused inputs of the device must be held at V_{CC} or GND to ensure proper device operation. Refer to the TI application report, *Implications of Slow or Floating CMOS Inputs*, literature number SCBA004.

4.4 Thermal Information

THERMAL METRIC ⁽¹⁾	SN74LV163A						UNIT
	D	DB	DGV	NS	PW	RGY	
	16 PINS	16 PINS	16 PINS	16 PINS	16 PINS	16 PINS	
$R_{\theta JA}$	Junction-to-ambient thermal resistance						°C/W
	73	82	120	64	108	39	

(1) For more information about traditional and new thermal metrics, see the [Semiconductor and IC Package Thermal Metrics](#) application report.

4.5 Electrical Characteristics

over recommended operating free-air temperature range (unless otherwise noted)

PARAMETER	TEST CONDITIONS	V_{CC}	SN74LV163A			UNIT
			MIN	TYP	MAX	
V_{OH}	$I_{OH} = -50 \mu\text{A}$	2 V to 5.5 V	$V_{CC} - 0.1$			V
	$I_{OH} = -2 \text{ mA}$	2.3 V	2			
	$I_{OH} = -6 \text{ mA}$	3 V	2.48			
	$I_{OH} = -12 \text{ mA}$	4.5 V	3.8			
V_{OL}	$I_{OL} = 50 \mu\text{A}$	2 V to 5.5 V	0.1			V
	$I_{OL} = 2 \text{ mA}$	2.3 V	0.4			
	$I_{OL} = 6 \text{ mA}$	3 V	0.44			
	$I_{OL} = 12 \text{ mA}$	4.5 V	0.55			
I_I	$V_I = 5.5 \text{ V or GND}$	0 to 5.5 V	± 1			μA
I_{CC}	$V_I = V_{CC} \text{ or GND, } I_O = 0$	5.5 V	20			μA
I_{off}	$V_I \text{ or } V_O = 0 \text{ to } 5.5 \text{ V}$	0	5			μA
C_i	$V_I = V_{CC} \text{ or GND}$	3.3 V	1.8			pF

4.6 Timing Requirements, $V_{CC} = 2.5\text{V} \pm 0.2\text{V}$

over recommended operating free-air temperature range, $V_{CC} = 2.5\text{V} \pm 0.2\text{V}$ (unless otherwise noted) (see [Load Circuit and Voltage Waveforms](#))

			$T_A = 25^\circ\text{C}$		SN74LV163A		UNIT
			MIN	MAX	MIN	MAX	
t_w	Pulse duration, CLK high or low		7	7		ns	
t_{su}	Setup time before CLK \uparrow	CLR	6	6		ns	
		Data (A, B, C, and D)	7.5	8.5			
		ENP, ENT	9.5	11			
		LOAD low	10	11.5			
t_h	Hold time, all synchronous inputs after CLK \uparrow		1.5	1.5		ns	

4.7 Timing Requirements, $V_{CC} = 3.3V \pm 0.3V$

over recommended operating free-air temperature range, $V_{CC} = 3.3V \pm 0.3V$ (unless otherwise noted) (see [Load Circuit and Voltage Waveforms](#))

		$T_A = 25^\circ\text{C}$		SN74LV163A		UNIT
		MIN	MAX	MIN	MAX	
t_w	Pulse duration, CLK high or low		5		5	ns
t_{su}	Setup time before CLK \uparrow	CLR	4		4	ns
		Data (A, B, C, and D)	5.5		6.5	
		ENP, ENT	7.5		9	
		LOAD low	8		9.5	
t_h	Hold time, all synchronous inputs after CLK \uparrow		1		1	ns

4.8 Timing Requirements, $V_{CC} = 5V \pm 0.5V$

over recommended operating free-air temperature range, $V_{CC} = 5V \pm 0.5V$ (unless otherwise noted) (see [Load Circuit and Voltage Waveforms](#))

		$T_A = 25^\circ\text{C}$		SN74LV163A		UNIT
		MIN	MAX	MIN	MAX	
t_w	Pulse duration, CLK high or low		5		5	ns
t_{su}	Setup time before CLK \uparrow	CLR	3.5		3.5	ns
		Data (A, B, C, and D)	4.5		4.5	
		ENP, ENT	5		6	
		LOAD low	5		6	
t_h	Hold time, all synchronous inputs after CLK \uparrow		1		1	ns

4.9 Switching Characteristics, $V_{CC} = 2.5V \pm 0.2V$

over recommended operating free-air temperature range, $V_{CC} = 2.5V \pm 0.2V$ (unless otherwise noted) (see [Load Circuit and Voltage Waveforms](#))

PARAMETER	FROM (INPUT)	TO (OUTPUT)	LOAD CAPACITANCE	$T_A = 25^\circ\text{C}$			SN74LV163A		UNIT
				MIN	TYP	MAX	MIN	MAX	
f_{max}			$C_L = 15\text{ pF}$	50 ⁽¹⁾	115 ⁽¹⁾		40		MHz
			$C_L = 50\text{ pF}$	30	90		25		
t_{pd}	CLK	Q	$C_L = 15\text{ pF}$	8.5 ⁽¹⁾	16.2 ⁽¹⁾		1	19.5	ns
		RCO (count mode)		9.1 ⁽¹⁾	17 ⁽¹⁾		1	20.5	
		RCO (preset mode)		12.1 ⁽¹⁾	20.6 ⁽¹⁾		1	24.5	
	ENT	RCO		8.7 ⁽¹⁾	15.7 ⁽¹⁾		1	19	
t_{pd}	CLK	Q	$C_L = 50\text{ pF}$	11	19.2		1	22.5	ns
		RCO (count mode)		11.9	20		1	23.5	
		RCO (preset mode)		14.6	23.6		1	27.5	
	ENT	RCO		11.7	18.7		1	22	

(1) On products compliant to MIL-PRF-38535, this parameter is not production tested.

4.10 Switching Characteristics, $V_{CC} = 3.3V \pm 0.3V$

over recommended operating free-air temperature range, $V_{CC} = 3.3V \pm 0.3V$ (unless otherwise noted) (see [Load Circuit and Voltage Waveforms](#))

PARAMETER	FROM (INPUT)	TO (OUTPUT)	LOAD CAPACITANCE	TA = 25°C			SN74LV163A		UNIT
				MIN	TYP	MAX	MIN	MAX	
f _{max}			C _L = 15 pF	80 ⁽¹⁾	160 ⁽¹⁾		70		MHz
			C _L = 50 pF	55	125		50		
t _{pd}	CLK	Q	C _L = 15 pF	6.2 ⁽¹⁾	12.8 ⁽¹⁾		1	15	ns
		RCO (count mode)		6.8 ⁽¹⁾	13.6 ⁽¹⁾		1	16	
		RCO (preset mode)		8.8 ⁽¹⁾	17.2 ⁽¹⁾		1	20	
	ENT	RCO		6.5 ⁽¹⁾	12.3 ⁽¹⁾		1	14.5	
t _{pd}	CLK	Q	C _L = 50 pF	8	16.3		1	18.5	ns
		RCO (count mode)		8.8	17.1		1	19.5	
		RCO (preset mode)		10.7	20.7		1	23.5	
	ENT	RCO		8.2	15.8		1	18	

(1) On products compliant to MIL-PRF-38535, this parameter is not production tested.

4.11 Switching Characteristics, $V_{CC} = 5V \pm 0.5V$

over recommended operating free-air temperature range, $V_{CC} = 5V \pm 0.5V$ (unless otherwise noted) (see [Load Circuit and Voltage Waveforms](#))

PARAMETER	FROM (INPUT)	TO (OUTPUT)	LOAD CAPACITANCE	TA = 25°C			SN74LV163A		UNIT
				MIN	TYP	MAX	MIN	MAX	
f _{max}			C _L = 15 pF	135 ⁽¹⁾	210 ⁽¹⁾		115		MHz
			C _L = 50 pF	95	160		85		
t _{pd}	CLK	Q	C _L = 15 pF	4.7 ⁽¹⁾	8.1 ⁽¹⁾		1	9.5	ns
		RCO (count mode)		5.2 ⁽¹⁾	8.1 ⁽¹⁾		1	9.5	
		RCO (preset mode)		6.4 ⁽¹⁾	10.3 ⁽¹⁾		1	12	
	ENT	RCO		4.9 ⁽¹⁾	8.1 ⁽¹⁾		1	9.5	
t _{pd}	CLK	Q	C _L = 50 pF	6.1	10.1		1	11.5	ns
		RCO (count mode)		6.6	10.1		1	11.5	
		RCO (preset mode)		7.8	12.3		1	14	
	ENT	RCO		6.3	10.1		1	11.5	

(1) On products compliant to MIL-PRF-38535, this parameter is not production tested.

4.12 Noise Characteristics

$V_{CC} = 3.3V$, $C_L = 50 pF$, $T_A = 25^\circ C$ ⁽¹⁾

PARAMETER	DESCRIPTION	SN74LV163A			UNIT
		MIN	TYP	MAX	
V _{OL(P)}	Quiet output, maximum dynamic V _{OL}		0.3	0.8	V
V _{OL(V)}	Quiet output, minimum dynamic V _{OL}		-0.2	-0.8	V
V _{OH(V)}	Quiet output, minimum dynamic V _{OH}		3		V
V _{IH(D)}	High-level dynamic input voltage	2.31			V

$V_{CC} = 3.3\text{ V}$, $C_L = 50\text{ pF}$, $T_A = 25^\circ\text{C}^{(1)}$

PARAMETER	SN74LV163A			UNIT
	MIN	TYP	MAX	
$V_{IL(D)}$ Low-level dynamic input voltage			0.99	V

(1) Characteristics are for surface-mount packages only.

4.13 Operating Characteristics

$T_A = 25^\circ\text{C}$

PARAMETER	TEST CONDITIONS	V_{CC}	TYP	UNIT
C_{pd} Power dissipation capacitance	$C_L = 50\text{ pF}$, $f = 10\text{ MHz}$	3.3 V	23.8	pF
		5 V	26	

4.14 Typical Clear, Preset, Count, and Inhibit Sequence

The following sequence is illustrated below:

1. Clear outputs to zero (synchronous)
2. Preset to binary 12
3. Count to 13, 14, 15, 0, 1, and 2
4. Inhibit

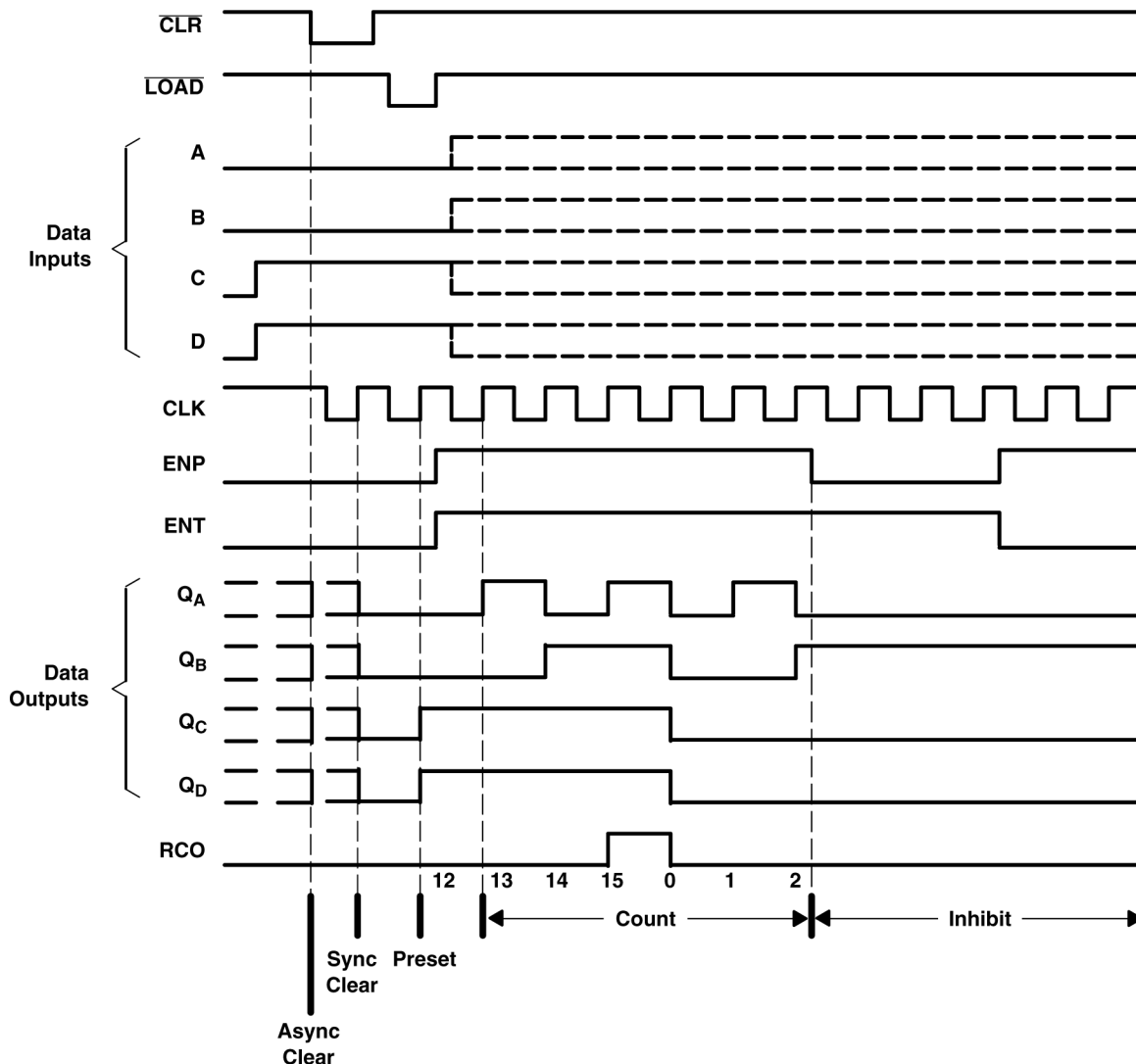

5 Parameter Measurement Information

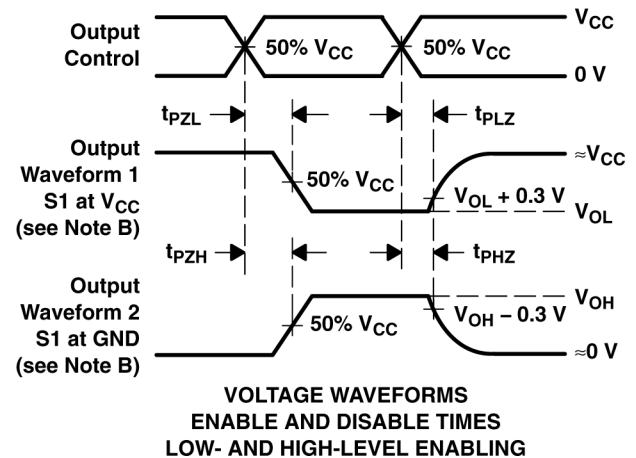
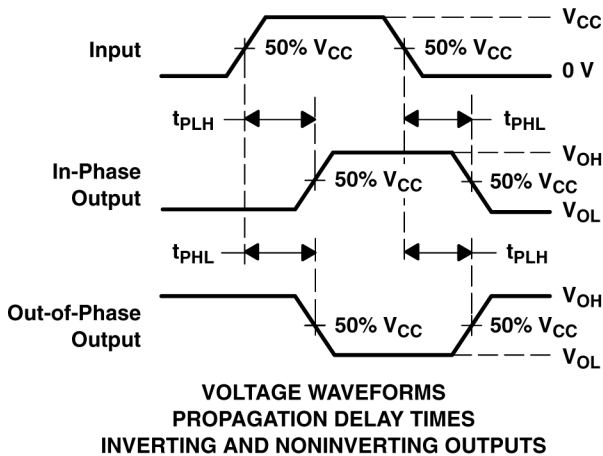
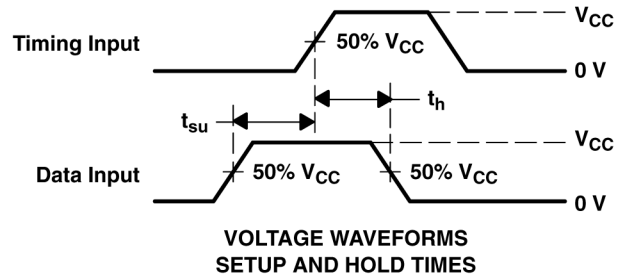
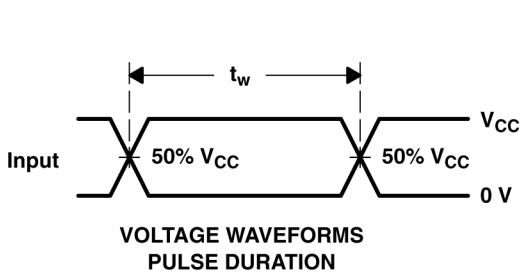
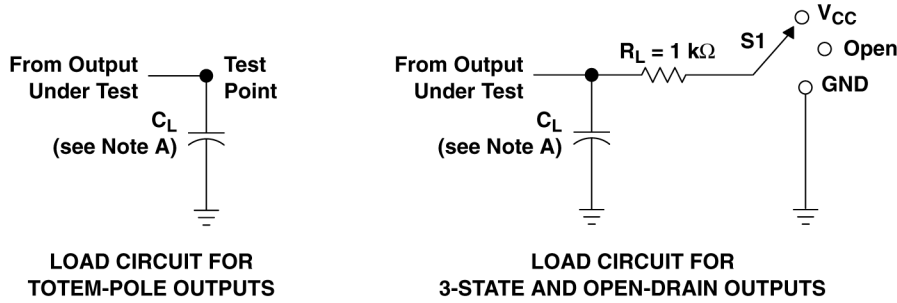

- A. C_L includes probe and jig capacitance.
- B. Waveform 1 is for an output with internal conditions such that the output is low, except when disabled by the output control. Waveform 2 is for an output with internal conditions such that the output is high, except when disabled by the output control.
- C. All input pulses are supplied by generators having the following characteristics: $PRR \leq 1 \text{ MHz}$, $Z_O = 50 \Omega$, $t_r \leq 3 \text{ ns}$, $t_f \leq 3 \text{ ns}$.
- D. The outputs are measured one at a time, with one input transition per measurement.
- E. t_{PLZ} and t_{PHZ} are the same as t_{dis} .
- F. t_{PZL} and t_{PZH} are the same as t_{en} .

- G. t_{PHL} and t_{PLH} are the same as t_{pd} .
- H. All parameters and waveforms are not applicable to all devices.

Figure 5-1. Load Circuit and Voltage Waveforms

TEST	S1
t_{PLH}/t_{PHL}	Open
t_{PLZ}/t_{PZL}	V_{CC}
t_{PHZ}/t_{PZH}	GND
Open Drain	V_{CC}

6 Detailed Description

6.1 Overview

The 'LV163A devices are 4-bit synchronous binary counters designed for 2-V to 5.5-V V_{CC} operation.

These synchronous, presettable counters feature an internal carry look ahead for application in high-speed counting designs. The 'LV163A devices are 4-bit binary counters. Synchronous operation is provided by having all flip-flops clocked simultaneously so that the outputs change coincident with each other when instructed by the count-enable (ENP, ENT) inputs and internal gating. This mode of operation eliminates the output counting spikes normally associated with synchronous (ripple-clock) counters. A buffered clock (CLK) input triggers the four flip-flops on the rising (positive-going) edge of the clock waveform.

These counters are fully programmable; that is, they can be preset to any number between 0 and 9 or 15. As presetting is synchronous, setting up a low level at the load input disables the counter and causes the outputs to agree with the setup data after the next clock pulse, regardless of the levels of the enable inputs.

The clear function for the 'LV163A devices is synchronous. A low level at the clear (\overline{CLR}) input sets all four of the flip-flop outputs low after the next low-to-high transition of CLK, regardless of the levels of the enable inputs. This synchronous clear allows the count length to be modified easily by decoding the Q outputs for the maximum count desired. The active-low output of the gate used for decoding is connected to \overline{CLR} to synchronously clear the counter to 0000 (LLLL).

The carry look-ahead circuitry provides for cascading counters for n-bit synchronous applications without additional gating. ENP, ENT, and a ripple-carry output (RCO) are instrumental in accomplishing this function. Both ENP and ENT must be high to count, and ENT is fed forward to enable RCO. Enabling RCO produces a high-level pulse while the count is maximum (9 or 15 with Q_A high). This high-level overflow ripple-carry pulse can be used to enable successive cascaded stages. Transitions at ENP or ENT are allowed, regardless of the level of CLK.

These counters feature a fully independent clock circuit. Changes at control inputs (ENP, ENT, or \overline{LOAD}) that modify the operating mode have no effect on the contents of the counter until clocking occurs. The function of the counter (whether enabled, disabled, loading, or counting) is dictated solely by the conditions meeting the stable setup and hold times.

These devices are fully specified for partial-power-down applications using I_{off} . The I_{off} circuitry disables the outputs, preventing damaging current backflow through the devices when they are powered down.

6.2 Functional Block Diagram

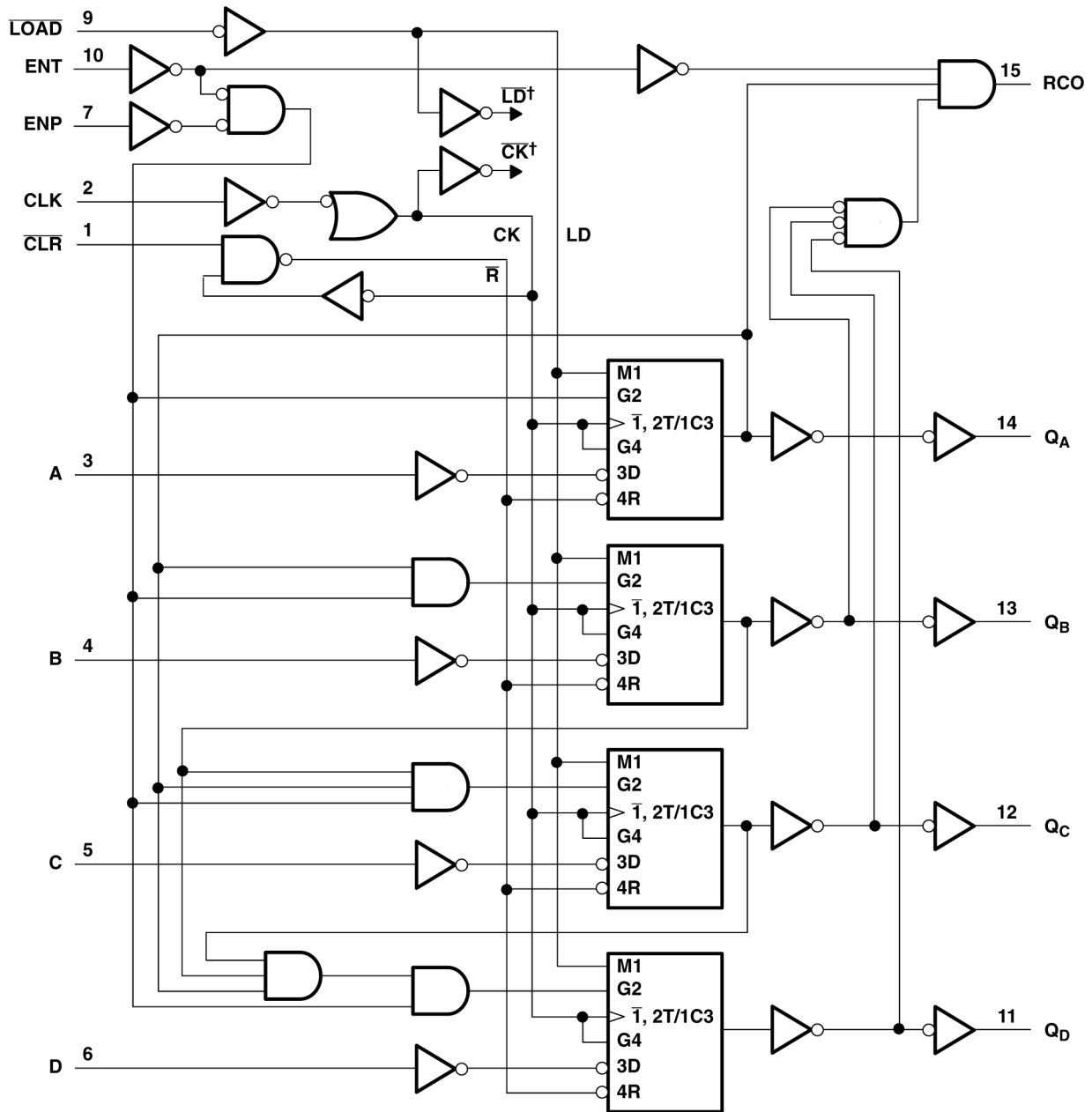

A. For simplicity, routing of complementary signals \overline{LD} and \overline{CK} is not shown on this overall logic diagram. The uses of these signals are shown on the logic diagram of the D/T flip-flops.

Figure 6-1. Logic Diagram (Positive Logic)

Pin numbers shown are for the D, DB, DGV, J, NS, PW, RGY, and W packages.

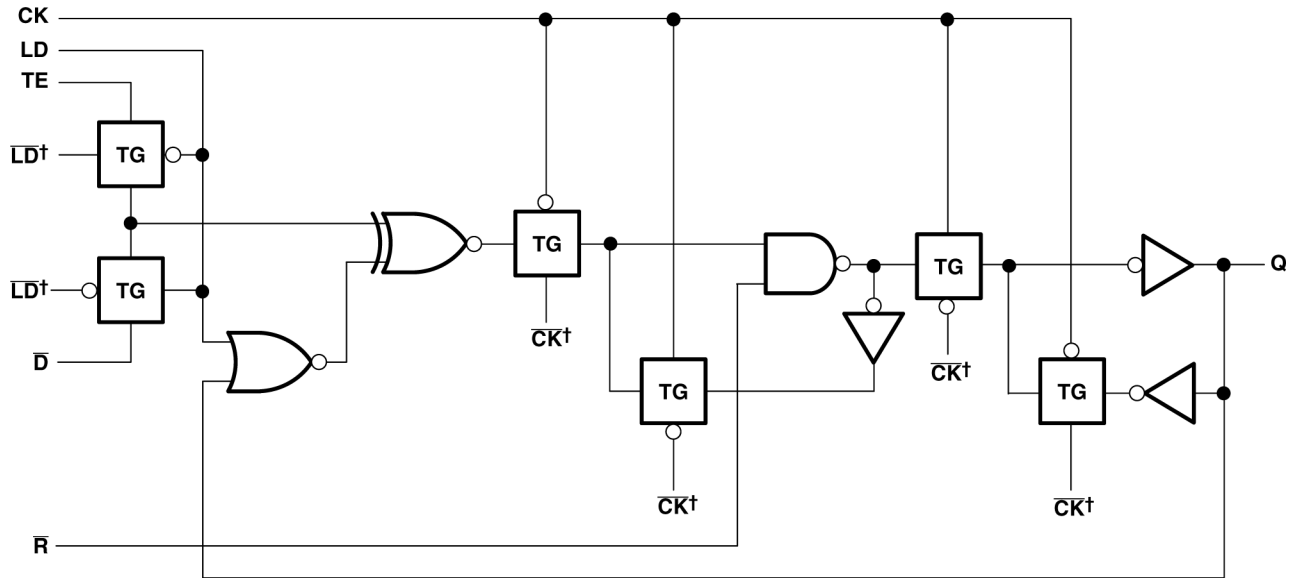

A. The origins of \overline{LD} and \overline{CK} are shown in the overall logic diagram of the device.

Figure 6-2. Logic Diagram, Each D/T Flip-flop (Positive Logic)

6.3 Device Functional Modes

Table 6-1. Function Table

INPUTS					OUTPUTS				FUNCTION
CLR	LOAD	ENP	ENT	CLK	QA	QB	QC	QD	
L	X	X	X	X	L	L	L	L	Reset to "0"
H	L	X	X		A	B	C	D	Preset data
H	H	X	L			No change			No count
H	H	L	X			No change			No count
H	H	H	H			Count up			Count
H	X	X	X			No change			No count

7 Application and Implementation

Note

Information in the following applications sections is not part of the TI component specification, and TI does not warrant its accuracy or completeness. TI's customers are responsible for determining suitability of components for their purposes, as well as validating and testing their design implementation to confirm system functionality.

7.1 Power Supply Recommendations

The power supply can be any voltage between the minimum and maximum supply voltage rating located in the *Recommended Operating Conditions*. Each V_{CC} terminal should have a good bypass capacitor to prevent power disturbance. A $0.1\mu\text{F}$ capacitor is recommended for this device. It is acceptable to parallel multiple bypass capacitors to reject different frequencies of noise. The $0.1\mu\text{F}$ and $1\mu\text{F}$ capacitors are commonly used in parallel. The bypass capacitor should be installed as close to the power terminal as possible for best results.

7.2 Layout

7.2.1 Layout Guidelines

- Bypass capacitor placement
 - Place near the positive supply terminal of the device
 - Provide an electrically short ground return path
 - Use wide traces to minimize impedance
 - Keep the device, capacitors, and traces on the same side of the board whenever possible
- Signal trace geometry
 - 8mil to 12mil trace width
 - Lengths less than 12cm to minimize transmission line effects
 - Avoid 90° corners for signal traces
 - Use an unbroken ground plane below signal traces
 - Flood fill areas around signal traces with ground
 - For traces longer than 12cm
 - Use impedance controlled traces
 - Source-terminate using a series damping resistor near the output
 - Avoid branches; buffer signals that must branch separately

7.2.2 Layout Example

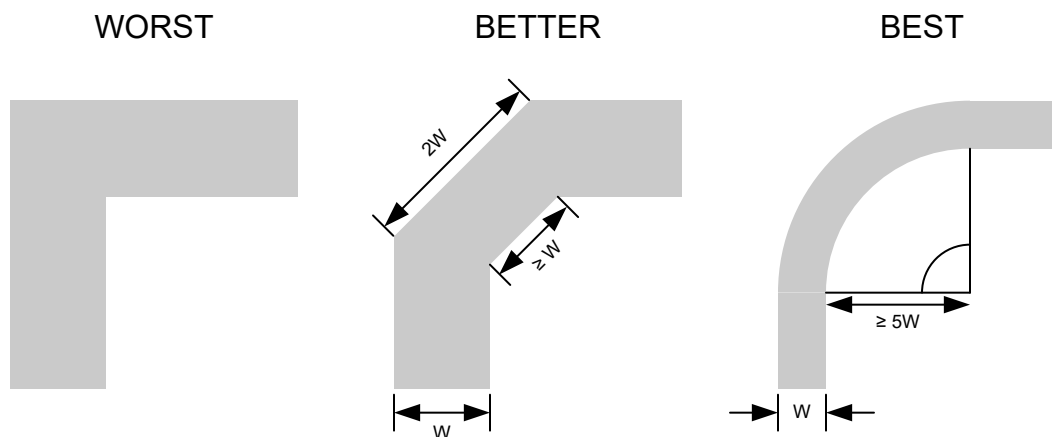

Figure 7-1. Example Trace Corners for Improved Signal Integrity

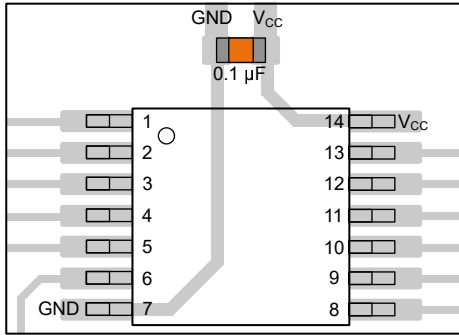

Figure 7-2. Example Bypass Capacitor Placement for TSSOP and Similar Packages

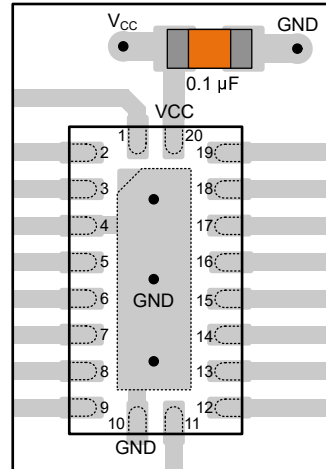

Figure 7-3. Example Bypass Capacitor Placement for WQFN and Similar Packages

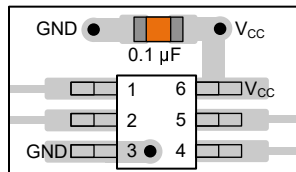

Figure 7-4. Example Bypass Capacitor Placement for SOT, SC70 and Similar Packages

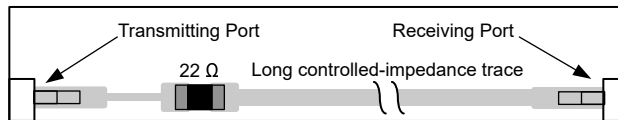

Figure 7-5. Example Damping Resistor Placement for Improved Signal Integrity

8 Device and Documentation Support

TI offers an extensive line of development tools. Tools and software to evaluate the performance of the device, generate code, and develop solutions are listed below.

8.1 Documentation Support

8.1.1 Related Documentation

For related documentation, see the following:

- Texas Instruments, [CMOS Power Consumption and \$C_{pd}\$ Calculation application report](#)
- Texas Instruments, [Designing With Logic application report](#)
- Texas Instruments, [Thermal Characteristics of Standard Linear and Logic \(SLL\) Packages and Devices application report](#)

8.2 Receiving Notification of Documentation Updates

To receive notification of documentation updates, navigate to the device product folder on ti.com. Click on *Notifications* to register and receive a weekly digest of any product information that has changed. For change details, review the revision history included in any revised document.

8.3 Support Resources

TI E2E™ [support forums](#) are an engineer's go-to source for fast, verified answers and design help — straight from the experts. Search existing answers or ask your own question to get the quick design help you need.

Linked content is provided "AS IS" by the respective contributors. They do not constitute TI specifications and do not necessarily reflect TI's views; see TI's [Terms of Use](#).

8.4 Trademarks

TI E2E™ is a trademark of Texas Instruments.

All trademarks are the property of their respective owners.

8.5 Electrostatic Discharge Caution



This integrated circuit can be damaged by ESD. Texas Instruments recommends that all integrated circuits be handled with appropriate precautions. Failure to observe proper handling and installation procedures can cause damage.

ESD damage can range from subtle performance degradation to complete device failure. Precision integrated circuits may be more susceptible to damage because very small parametric changes could cause the device not to meet its published specifications.

8.6 Glossary

[TI Glossary](#) This glossary lists and explains terms, acronyms, and definitions.

9 Revision History

NOTE: Page numbers for previous revisions may differ from page numbers in the current version.

Changes from Revision F (April 2005) to Revision G (January 2025)	Page
• Added <i>Package Information</i> table, <i>Pin Functions</i> table, <i>ESD Ratings</i> table, <i>Thermal Information</i> table, <i>Device Functional Modes</i> , Application and Implementation section, <i>Device and Documentation Support</i> section, and <i>Mechanical, Packaging, and Orderable Information</i> section	1
• Deleted references to SN54LV163A product preview	1

10 Mechanical, Packaging, and Orderable Information

The following pages include mechanical, packaging, and orderable information. This information is the most current data available for the designated devices. This data is subject to change without notice and revision of this document. For browser-based versions of this data sheet, refer to the left-hand navigation.

PACKAGING INFORMATION

Orderable part number	Status (1)	Material type (2)	Package Pins	Package qty Carrier	RoHS (3)	Lead finish/ Ball material (4)	MSL rating/ Peak reflow (5)	Op temp (°C)	Part marking (6)
SN74LV163AD	Obsolete	Production	SOIC (D) 16	-	-	Call TI	Call TI	-40 to 85	LV163A
SN74LV163ADBR	Active	Production	SSOP (DB) 16	2000 LARGE T&R	Yes	NIPDAU	Level-1-260C-UNLIM	-40 to 85	LV163A
SN74LV163ADBR.A	Active	Production	SSOP (DB) 16	2000 LARGE T&R	Yes	NIPDAU	Level-1-260C-UNLIM	-40 to 85	LV163A
SN74LV163ADGVR	NRND	Production	TVSOP (DGV) 16	2000 LARGE T&R	Yes	NIPDAU	Level-1-260C-UNLIM	-40 to 85	LV163A
SN74LV163ADGVR.A	NRND	Production	TVSOP (DGV) 16	2000 LARGE T&R	Yes	NIPDAU	Level-1-260C-UNLIM	-40 to 85	LV163A
SN74LV163ADR	NRND	Production	SOIC (D) 16	2500 LARGE T&R	Yes	NIPDAU	Level-1-260C-UNLIM	-40 to 85	LV163A
SN74LV163ADR.A	NRND	Production	SOIC (D) 16	2500 LARGE T&R	Yes	NIPDAU	Level-1-260C-UNLIM	-40 to 85	LV163A
SN74LV163ANSR	Active	Production	SOP (NS) 16	2000 LARGE T&R	Yes	NIPDAU	Level-1-260C-UNLIM	-40 to 85	74LV163A
SN74LV163ANSR.A	Active	Production	SOP (NS) 16	2000 LARGE T&R	Yes	NIPDAU	Level-1-260C-UNLIM	-40 to 85	74LV163A
SN74LV163APW	Obsolete	Production	TSSOP (PW) 16	-	-	Call TI	Call TI	-40 to 85	LV163A
SN74LV163APWR	Active	Production	TSSOP (PW) 16	2000 LARGE T&R	Yes	NIPDAU SN	Level-1-260C-UNLIM	-40 to 85	LV163A
SN74LV163APWR.A	Active	Production	TSSOP (PW) 16	2000 LARGE T&R	Yes	NIPDAU	Level-1-260C-UNLIM	-40 to 85	LV163A
SN74LV163APWRG4	Active	Production	TSSOP (PW) 16	2000 LARGE T&R	No	NIPDAU	Level-1-260C-UNLIM	-40 to 85	LV163A
SN74LV163APWRG4	Active	Production	TSSOP (PW) 16	2000 LARGE T&R	Yes	NIPDAU	Level-1-260C-UNLIM	-40 to 85	LV163A
SN74LV163APWRG4.A	Active	Production	TSSOP (PW) 16	2000 LARGE T&R	No	NIPDAU	Level-1-260C-UNLIM	-40 to 85	LV163A
SN74LV163APWRG4.A	Active	Production	TSSOP (PW) 16	2000 LARGE T&R	Yes	NIPDAU	Level-1-260C-UNLIM	-40 to 85	LV163A
SN74LV163ARGYR	Active	Production	VQFN (RGY) 16	3000 LARGE T&R	Yes	SN	Level-1-260C-UNLIM	-40 to 85	LV163A
SN74LV163ARGYR.A	Active	Production	VQFN (RGY) 16	3000 LARGE T&R	Yes	SN	Level-1-260C-UNLIM	-40 to 85	LV163A

(1) **Status:** For more details on status, see our [product life cycle](#).

(2) **Material type:** When designated, preproduction parts are prototypes/experimental devices, and are not yet approved or released for full production. Testing and final process, including without limitation quality assurance, reliability performance testing, and/or process qualification, may not yet be complete, and this item is subject to further changes or possible discontinuation. If available for ordering, purchases will be subject to an additional waiver at checkout, and are intended for early internal evaluation purposes only. These items are sold without warranties of any kind.

(3) **RoHS values:** Yes, No, RoHS Exempt. See the [TI RoHS Statement](#) for additional information and value definition.

(4) **Lead finish/Ball material:** Parts may have multiple material finish options. Finish options are separated by a vertical ruled line. Lead finish/Ball material values may wrap to two lines if the finish value exceeds the maximum column width.

(5) **MSL rating/Peak reflow:** The moisture sensitivity level ratings and peak solder (reflow) temperatures. In the event that a part has multiple moisture sensitivity ratings, only the lowest level per JEDEC standards is shown. Refer to the shipping label for the actual reflow temperature that will be used to mount the part to the printed circuit board.

(6) **Part marking:** There may be an additional marking, which relates to the logo, the lot trace code information, or the environmental category of the part.

Multiple part markings will be inside parentheses. Only one part marking contained in parentheses and separated by a "~" will appear on a part. If a line is indented then it is a continuation of the previous line and the two combined represent the entire part marking for that device.

Important Information and Disclaimer:The information provided on this page represents TI's knowledge and belief as of the date that it is provided. TI bases its knowledge and belief on information provided by third parties, and makes no representation or warranty as to the accuracy of such information. Efforts are underway to better integrate information from third parties. TI has taken and continues to take reasonable steps to provide representative and accurate information but may not have conducted destructive testing or chemical analysis on incoming materials and chemicals. TI and TI suppliers consider certain information to be proprietary, and thus CAS numbers and other limited information may not be available for release.

In no event shall TI's liability arising out of such information exceed the total purchase price of the TI part(s) at issue in this document sold by TI to Customer on an annual basis.

TAPE AND REEL INFORMATION

QUADRANT ASSIGNMENTS FOR PIN 1 ORIENTATION IN TAPE

*All dimensions are nominal

Device	Package Type	Package Drawing	Pins	SPQ	Reel Diameter (mm)	Reel Width W1 (mm)	A0 (mm)	B0 (mm)	K0 (mm)	P1 (mm)	W (mm)	Pin1 Quadrant
SN74LV163ADBR	SSOP	DB	16	2000	330.0	16.4	8.35	6.6	2.4	12.0	16.0	Q1
SN74LV163ADGVR	TVSOP	DGV	16	2000	330.0	12.4	6.8	4.0	1.6	8.0	12.0	Q1
SN74LV163ADR	SOIC	D	16	2500	330.0	16.4	6.5	10.3	2.1	8.0	16.0	Q1
SN74LV163ANSR	SOP	NS	16	2000	330.0	16.4	8.1	10.4	2.5	12.0	16.0	Q1
SN74LV163APWR	TSSOP	PW	16	2000	330.0	12.4	6.9	5.6	1.6	8.0	12.0	Q1
SN74LV163APWRG4	TSSOP	PW	16	2000	330.0	12.4	6.9	5.6	1.6	8.0	12.0	Q1
SN74LV163ARGYR	VQFN	RGY	16	3000	330.0	12.4	3.8	4.3	1.5	8.0	12.0	Q1

TAPE AND REEL BOX DIMENSIONS

*All dimensions are nominal

Device	Package Type	Package Drawing	Pins	SPQ	Length (mm)	Width (mm)	Height (mm)
SN74LV163ADBR	SSOP	DB	16	2000	353.0	353.0	32.0
SN74LV163ADGVR	TVSOP	DGV	16	2000	353.0	353.0	32.0
SN74LV163ADR	SOIC	D	16	2500	353.0	353.0	32.0
SN74LV163ANSR	SOP	NS	16	2000	353.0	353.0	32.0
SN74LV163APWR	TSSOP	PW	16	2000	353.0	353.0	32.0
SN74LV163APWRG4	TSSOP	PW	16	2000	353.0	353.0	32.0
SN74LV163ARGYR	VQFN	RGY	16	3000	360.0	360.0	36.0



PACKAGE OUTLINE

NS0016A

SOP - 2.00 mm max height

SOP



NOTES:

1. All linear dimensions are in millimeters. Dimensions in parenthesis are for reference only. Dimensioning and tolerancing per ASME Y14.5M.
2. This drawing is subject to change without notice.
3. This dimension does not include mold flash, protrusions, or gate burrs. Mold flash, protrusions, or gate burrs shall not exceed 0.15 mm, per side.
4. This dimension does not include interlead flash. Interlead flash shall not exceed 0.25 mm, per side.

EXAMPLE BOARD LAYOUT

NS0016A

SOP - 2.00 mm max height

SOP



4220735/A 12/2021

NOTES: (continued)

5. Publication IPC-7351 may have alternate designs.

6. Solder mask tolerances between and around signal pads can vary based on board fabrication site.

EXAMPLE STENCIL DESIGN

NS0016A

SOP - 2.00 mm max height

SOP



SOLDER PASTE EXAMPLE
BASED ON 0.125 mm THICK STENCIL
SCALE:7X

4220735/A 12/2021

NOTES: (continued)

7. Laser cutting apertures with trapezoidal walls and rounded corners may offer better paste release. IPC-7525 may have alternate design recommendations.
8. Board assembly site may have different recommendations for stencil design.

D (R-PDSO-G16)

PLASTIC SMALL OUTLINE



- NOTES:
- A. All linear dimensions are in inches (millimeters).
 - B. This drawing is subject to change without notice.
 - C. Body length does not include mold flash, protrusions, or gate burrs. Mold flash, protrusions, or gate burrs shall not exceed 0.006 (0,15) each side.
 - D. Body width does not include interlead flash. Interlead flash shall not exceed 0.017 (0,43) each side.
 - E. Reference JEDEC MS-012 variation AC.

DB0016A



PACKAGE OUTLINE

SSOP - 2 mm max height

SMALL OUTLINE PACKAGE



4220763/A 05/2022

NOTES:

1. All linear dimensions are in millimeters. Any dimensions in parenthesis are for reference only. Dimensioning and tolerancing per ASME Y14.5M.
2. This drawing is subject to change without notice.
3. This dimension does not include mold flash, protrusions, or gate burrs. Mold flash, protrusions, or gate burrs shall not exceed 0.15 mm per side.
4. Reference JEDEC registration MO-150.

EXAMPLE BOARD LAYOUT

DB0016A

SSOP - 2 mm max height

SMALL OUTLINE PACKAGE



LAND PATTERN EXAMPLE
EXPOSED METAL SHOWN
SCALE: 10X



4220763/A 05/2022

NOTES: (continued)

- 5. Publication IPC-7351 may have alternate designs.
- 6. Solder mask tolerances between and around signal pads can vary based on board fabrication site.

DGV (R-PDSO-G**)

PLASTIC SMALL-OUTLINE

24 PINS SHOWN



- NOTES: A. All linear dimensions are in millimeters.
 B. This drawing is subject to change without notice.
 C. Body dimensions do not include mold flash or protrusion, not to exceed 0,15 per side.
 D. Falls within JEDEC: 24/48 Pins – MO-153
 14/16/20/56 Pins – MO-194

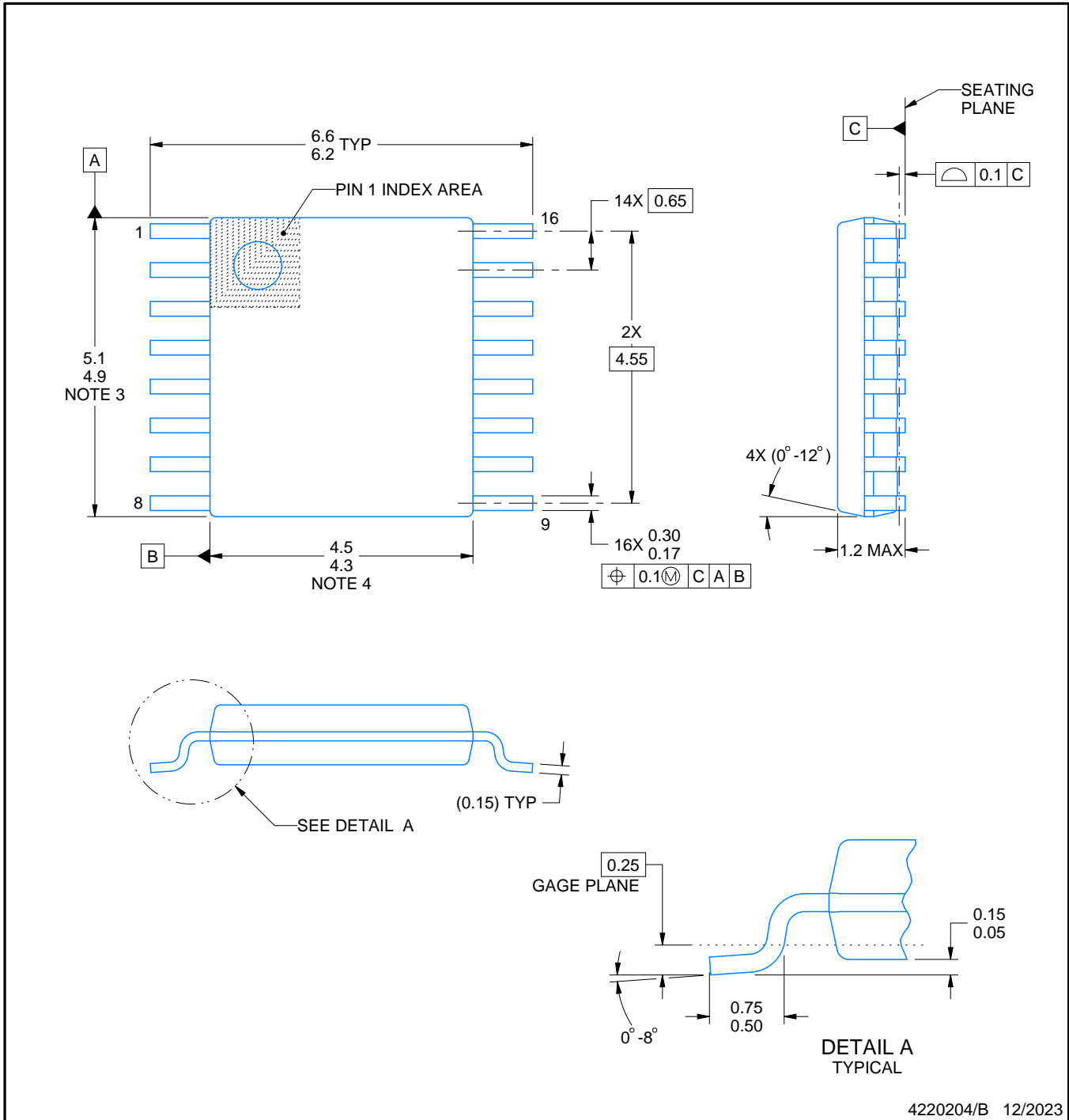

4220204/B 12/2023

NOTES:

1. All linear dimensions are in millimeters. Any dimensions in parenthesis are for reference only. Dimensioning and tolerancing per ASME Y14.5M.
2. This drawing is subject to change without notice.
3. This dimension does not include mold flash, protrusions, or gate burrs. Mold flash, protrusions, or gate burrs shall not exceed 0.15 mm per side.
4. This dimension does not include interlead flash. Interlead flash shall not exceed 0.25 mm per side.
5. Reference JEDEC registration MO-153.

EXAMPLE BOARD LAYOUT

PW0016A

TSSOP - 1.2 mm max height

SMALL OUTLINE PACKAGE

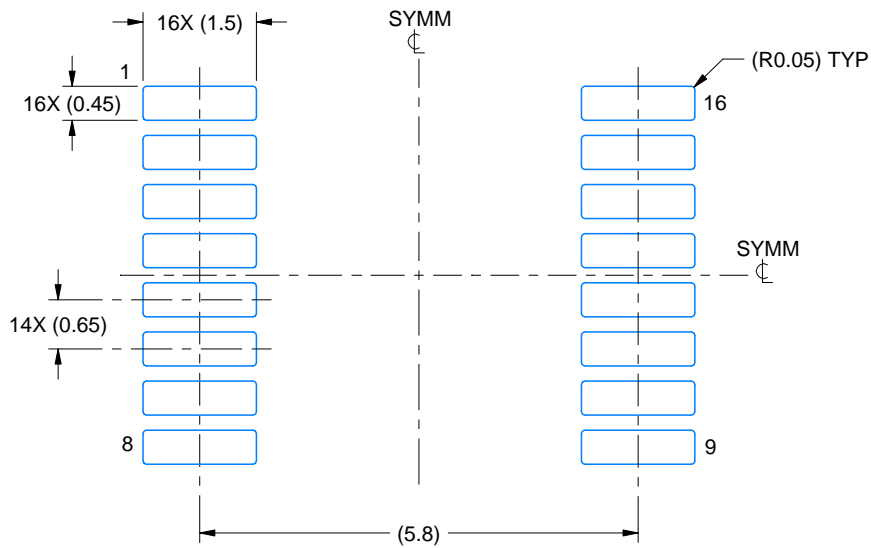

LAND PATTERN EXAMPLE
EXPOSED METAL SHOWN
SCALE: 10X



SOLDER MASK DETAILS

4220204/B 12/2023

NOTES: (continued)

- 6. Publication IPC-7351 may have alternate designs.
- 7. Solder mask tolerances between and around signal pads can vary based on board fabrication site.

EXAMPLE STENCIL DESIGN

PW0016A

TSSOP - 1.2 mm max height

SMALL OUTLINE PACKAGE



SOLDER PASTE EXAMPLE
BASED ON 0.125 mm THICK STENCIL
SCALE: 10X

4220204/B 12/2023

NOTES: (continued)

8. Laser cutting apertures with trapezoidal walls and rounded corners may offer better paste release. IPC-7525 may have alternate design recommendations.
9. Board assembly site may have different recommendations for stencil design.

RGY (R-PVQFN-N16)

PLASTIC QUAD FLATPACK NO-LEAD

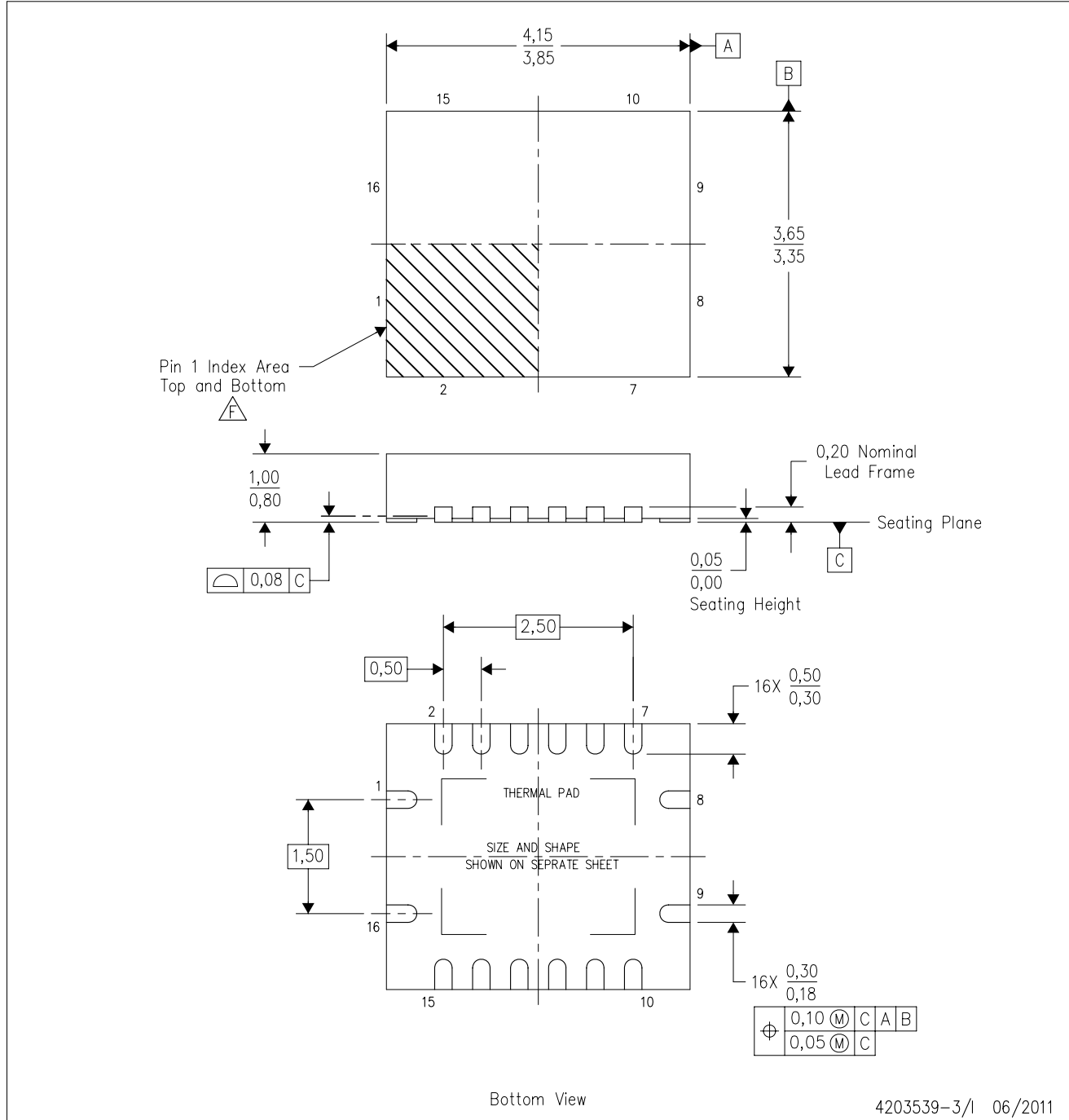

- NOTES:
- A. All linear dimensions are in millimeters. Dimensioning and tolerancing per ASME Y14.5M-1994.
 - B. This drawing is subject to change without notice.
 - C. QFN (Quad Flatpack No-Lead) package configuration.
 - D. The package thermal pad must be soldered to the board for thermal and mechanical performance.
 - E. See the additional figure in the Product Data Sheet for details regarding the exposed thermal pad features and dimensions.
 - F. Pin 1 identifiers are located on both top and bottom of the package and within the zone indicated. The Pin 1 identifiers are either a molded, marked, or metal feature.
 - G. Package complies to JEDEC MO-241 variation BA.

IMPORTANT NOTICE AND DISCLAIMER

TI PROVIDES TECHNICAL AND RELIABILITY DATA (INCLUDING DATASHEETS), DESIGN RESOURCES (INCLUDING REFERENCE DESIGNS), APPLICATION OR OTHER DESIGN ADVICE, WEB TOOLS, SAFETY INFORMATION, AND OTHER RESOURCES "AS IS" AND WITH ALL FAULTS, AND DISCLAIMS ALL WARRANTIES, EXPRESS AND IMPLIED, INCLUDING WITHOUT LIMITATION ANY IMPLIED WARRANTIES OF MERCHANTABILITY, FITNESS FOR A PARTICULAR PURPOSE OR NON-INFRINGEMENT OF THIRD PARTY INTELLECTUAL PROPERTY RIGHTS.

These resources are intended for skilled developers designing with TI products. You are solely responsible for (1) selecting the appropriate TI products for your application, (2) designing, validating and testing your application, and (3) ensuring your application meets applicable standards, and any other safety, security, regulatory or other requirements.

These resources are subject to change without notice. TI grants you permission to use these resources only for development of an application that uses the TI products described in the resource. Other reproduction and display of these resources is prohibited. No license is granted to any other TI intellectual property right or to any third party intellectual property right. TI disclaims responsibility for, and you fully indemnify TI and its representatives against any claims, damages, costs, losses, and liabilities arising out of your use of these resources.

TI's products are provided subject to [TI's Terms of Sale](#), [TI's General Quality Guidelines](#), or other applicable terms available either on ti.com or provided in conjunction with such TI products. TI's provision of these resources does not expand or otherwise alter TI's applicable warranties or warranty disclaimers for TI products. Unless TI explicitly designates a product as custom or customer-specified, TI products are standard, catalog, general purpose devices.

TI objects to and rejects any additional or different terms you may propose.

Copyright © 2026, Texas Instruments Incorporated

Last updated 10/2025