

RES11A-Q1 Automotive, Matched, Thin-Film Resistor Dividers With 1-kΩ Inputs

1 Features

- AEC-Q200 Qualified for automotive applications:
 - Temperature: -40°C to $+125^{\circ}\text{C}$
- High ratio matching precision: $\pm 0.05\%$ (maximum)
- Low drift: $\pm 2\text{ ppm}/^{\circ}\text{C}$ TCR (maximum)

2 Applications

- Precision voltage divider, precision level translation
- Gain and attenuating amplifiers
- Difference amplifiers with high CMRR
- Discrete instrumentation amps with high gain accuracy
- Fully differential amplifiers with high gain accuracy
- Pinpoint comparator threshold setting

3 Description

The RES11A-Q1 is a matched pair of resistive dividers, implemented in thin-film SiCr with Texas Instruments' modern, high-performance, analog CMOS process. The device has a nominal input resistance of 1 kΩ, for low thermal and current noise, and is available in several nominal ratios to meet a wide array of system needs. Use the RES11A-Q1 in an inverse gain configuration by simply rotating the device placement by 180° . This feature supports layout reuse and increases flexibility for applications such as discrete instrumentation or difference amplifier implementations.

The RES11A-Q1 series features high ratio-matching precision, with the measured ratio of each divider within $\pm 120\text{ ppm}$ (typical) of the nominal. This precision is maintained over the temperature range,

with a maximum ratio drift of only $\pm 2\text{ ppm}/^{\circ}\text{C}$. Additionally, the biased long-term stability of the device has been proven through thorough characterization.

The RES11A-Q1 is automotive qualified under AEC-Q200 temperature grade 1. The temperature range is specified from -40°C to $+125^{\circ}\text{C}$. The device is offered in an 8-pin, SOT-23-THIN package, with a body size of $2.9\text{ mm} \times 1.6\text{ mm}$ (body size is a nominal value and does not include pins).

Package Information

PART NUMBER	PACKAGE ⁽¹⁾	PACKAGE SIZE ⁽²⁾
RES11A-Q1	DDF (SOT-23-THIN, 8)	2.9 mm × 2.8 mm

- (1) For more information, see [Section 11](#).
 (2) The package size (length × width) is a nominal value and includes pins, where applicable.

Device Information

PART NUMBER	NOMINAL RATIO
RES11A10-Q1	1:1
RES11A15-Q1 ⁽¹⁾	1:1.5
RES11A16-Q1 ⁽¹⁾	1:1.667
RES11A20-Q1 ⁽¹⁾	1:2
RES11A25-Q1 ⁽¹⁾	1:2.5
RES11A30-Q1 ⁽¹⁾	1:3
RES11A40-Q1	1:4
RES11A50-Q1 ⁽¹⁾	1:5
RES11A90-Q1	1:9
RES11A00-Q1	1:10

- (1) Preview information (not Advanced Information).

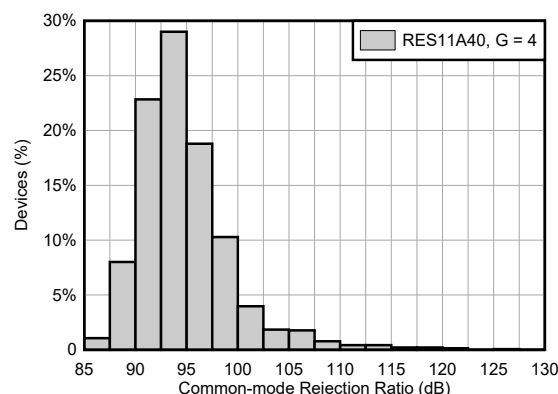
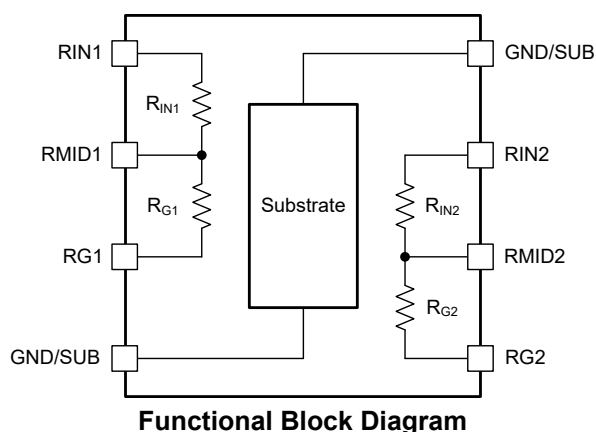

Table of Contents

1 Features	1	7.4 Device Functional Modes.....	18
2 Applications	1	8 Application and Implementation	19
3 Description	1	8.1 Application Information.....	19
4 Pin Configuration and Functions	3	8.2 Typical Application.....	23
5 Specifications	4	8.3 Power Supply Recommendations.....	26
5.1 Absolute Maximum Ratings.....	4	8.4 Layout.....	26
5.2 ESD Ratings.....	4	9 Device and Documentation Support	29
5.3 Recommended Operating Conditions.....	5	9.1 Device Support.....	29
5.4 Thermal Information.....	5	9.2 Documentation Support.....	30
5.5 Electrical Characteristics.....	6	9.3 Receiving Notification of Documentation Updates... 30	
5.6 AEC-Q200 Qualification Testing.....	8	9.4 Support Resources.....	30
5.7 Typical Characteristics.....	9	9.5 Trademarks.....	30
6 Parameter Measurement Information	13	9.6 Electrostatic Discharge Caution.....	30
6.1 DC Measurement Configurations.....	13	9.7 Glossary.....	30
6.2 AC Measurement Configurations.....	14	10 Revision History	30
7 Detailed Description	15	11 Mechanical, Packaging, and Orderable Information	31
7.1 Overview.....	15	11.1 Tape and Reel Information.....	31
7.2 Functional Block Diagram.....	15	11.2 Mechanical Data.....	33
7.3 Feature Description.....	15		

4 Pin Configuration and Functions

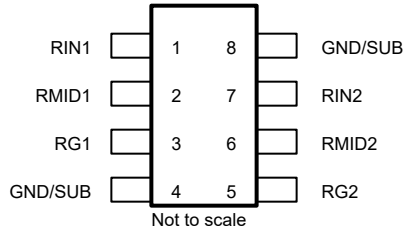

Figure 4-1. DDF Package, 8-Pin SOT-23-THN (Top View)

Table 4-1. Pin Functions

PIN		TYPE	DESCRIPTION
NAME	NO.		
GND/SUB	4, 8	Ground	Substrate bias connection. Only bias one GND/SUB pin. Float the other GND/SUB pin to prevent current return paths from forming through the substrate. See also Section 7.4 .
RG1	3	Input	Gain resistor connection for divider 1
RG2	5	Input	Gain resistor connection for divider 2
RIN1	1	Input	Input resistor connection for divider 1
RIN2	7	Input	Input resistor connection for divider 2
RMID1	2	Output	Center tap of divider 1
RMID2	6	Output	Center tap of divider 2

5 Specifications

5.1 Absolute Maximum Ratings

over operating free-air temperature range (unless otherwise noted)⁽¹⁾

		MIN	MAX	UNIT
V _{CM}	Maximum common mode voltage (any pin to GND/SUB)		±135	V
ΔV _{DMAX}	Maximum instantaneous overload voltage per divider (RINx pin to RGx pin) ⁽²⁾	RES11A10	±77.0	V
		RES11A15	±64.2	
		RES11A16	±63.0	
		RES11A20	±57.8	
		RES11A25	±89.9	
		RES11A30	±102.7	
		RES11A40	±96.3	
		RES11A50	±94.6	
		RES11A90	±128.4	
RES11A00	±135			
T _A	Ambient temperature	–55	150	°C
T _J	Junction temperature	–55	150	°C
T _{stg}	Storage temperature	–55	175	°C

- Operation outside the *Absolute Maximum Ratings* may cause permanent device damage. *Absolute Maximum Ratings* do not imply functional operation of the device at these or any other conditions beyond those listed under *Recommended Operating Conditions*. If used outside the *Recommended Operating Conditions* but within the *Absolute Maximum Ratings*, the device may not be fully functional, and this may affect device reliability, functionality, performance, and shorten the device lifetime.
- Maximum instantaneous voltage permitted under transient conditions. Avoid sustained operation at these voltage levels because the resulting self-heating causes T_J to exceed 150°C.

5.2 ESD Ratings

		VALUE	UNIT
V _(ESD)	Electrostatic discharge	Human body model (HBM), per AEC Q100-002 ⁽¹⁾	±1200
		Charged device model (CDM), per AEC Q100-011	±2000

- AEC Q100-002 indicates that HBM stressing must be in accordance with the ANSI/ESDA/JEDEC JS-001 specification.

5.3 Recommended Operating Conditions

over operating free-air temperature range (unless otherwise noted)

		MIN	NOM	MAX	UNIT
	Maximum common-mode voltage (any pin to GND/SUB)			±120	V
Maximum sustained current through R _{INx} (RINx pin to RMIDx pin, 10 years at T _A = 25°C) ⁽¹⁾	RES11A10		±8.93	±12.2	mA
	RES11A15		±8.93	±12.2	
	RES11A16		±8.93	±12.5	
	RES11A20		±8.93	±12.2	
	RES11A25		±7.44	±10.2	
	RES11A30		±8.93	±12.2	
	RES11A40		±8.93	±12.2	
	RES11A50		±8.93	±12.5	
	RES11A90		±8.93	±12.2	
	RES11A00		±7.44	±10.2	
Maximum sustained current through R _{Gx} (RGx pin to RMIDx pin, 10 years at T _A = 25°C) ⁽¹⁾	RES11A10		±8.93	±12.2	mA
	RES11A15		±5.95	±8.14	
	RES11A16		±5.36	±7.49	
	RES11A20		±4.47	±6.11	
	RES11A25		±5.95	±8.14	
	RES11A30		±5.95	±8.14	
	RES11A40		±4.47	±6.11	
	RES11A50		±3.57	±5.00	
	RES11A90		±2.98	±4.07	
	RES11A00		±2.98	±4.07	
T _A	Ambient temperature	−40		125	°C

(1) Assumes R_{θJA} = 156.2 °C/W. Applies whether the specified current is applied across a *single* divider, or *both* dividers simultaneously. For long-term use under static dc biases, keep the current less than or equal to the nominal value. For long-term use under dynamic conditions, keep the RMS current less than or equal to the maximum value. Adhere to the limitations in *Absolute Maximum Ratings*.

5.4 Thermal Information

THERMAL METRIC ⁽¹⁾		RES11A-Q1	UNIT
		DDF (SOT-23-THIN)	
		8 PINS	
R _{θJA}	Junction-to-ambient thermal resistance	156.2	°C/W
R _{θJC(top)}	Junction-to-case (top) thermal resistance	77.0	°C/W
R _{θJB}	Junction-to-board thermal resistance	73.7	°C/W
ψ _{JT}	Junction-to-top characterization parameter	4.5	°C/W
ψ _{JB}	Junction-to-board characterization parameter	73.5	°C/W
R _{θJC(bot)}	Junction-to-case (bottom) thermal resistance	N/A	°C/W

(1) For more information about traditional and new thermal metrics, see the [Semiconductor and IC Package Thermal Metrics](#) application report.

ADVANCE INFORMATION

5.5 Electrical Characteristics

 at $T_A = 25^\circ\text{C}$ (unless otherwise noted)

PARAMETER		TEST CONDITIONS	MIN	TYP	MAX	UNIT	
INITIAL RESISTANCE							
G_{nom}	Nominal ratio (R_{Gx} / R_{INx})	RES11A10		1		V/V	
		RES11A15		1.5			
		RES11A16		1.667			
		RES11A20		2			
		RES11A25		2.5			
		RES11A30		3			
		RES11A40		4			
		RES11A50		5			
		RES11A90		9			
		RES11A00		10			
t_{D1}	Ratio tolerance of divider 1 ⁽¹⁾	$(R_{G1} / R_{IN1}) / G_{nom} - 1$	RES11A10			±500	ppm
			RES11A15			±500	
			RES11A16			±500	
			RES11A20			±500	
			RES11A25			±500	
			RES11A30			±500	
			RES11A40		±120	±500	
			RES11A50			±500	
			RES11A90			±500	
			RES11A00			±500	
	Voltage-divider circuit tolerance of divider 1	$(1 + G_{nom}) \times (R_{IN1} / (R_{IN1} + R_{G1})) - 1$	RES11A10			±500	ppm
			RES11A15			±500	
			RES11A16			±500	
			RES11A20			±500	
			RES11A25			±500	
			RES11A30			±500	
			RES11A40		±100	±500	
			RES11A50			±500	
			RES11A90			±500	
			RES11A00			±500	
t_{D2}	Ratio tolerance of divider 2 ⁽¹⁾	$(R_{G2} / R_{IN2}) / G_{nom} - 1$	RES11A10			±500	ppm
			RES11A15			±500	
			RES11A16			±500	
			RES11A20			±500	
			RES11A25			±500	
			RES11A30			±500	
			RES11A40		±120	±500	
			RES11A50			±500	
			RES11A90			±500	
			RES11A00			±500	

ADVANCE INFORMATION

5.5 Electrical Characteristics (continued)

at T_A = 25°C (unless otherwise noted)

PARAMETER		TEST CONDITIONS		MIN	TYP	MAX	UNIT
	Voltage-divider circuit tolerance of divider 2	$(1 + G_{nom}) \times (R_{IN2} / (R_{IN2} + R_{G2})) - 1$	RES11A10			±500	ppm
			RES11A15			±500	
			RES11A16			±500	
			RES11A20			±500	
			RES11A25			±500	
			RES11A30			±500	
			RES11A40		±100	±500	
			RES11A50			±500	
			RES11A90			±500	
			RES11A00			±500	
t _M	Matching tolerance of dividers 1 and 2	t _{D2} - t _{D1}	RES11A10			±1000	ppm
			RES11A15			±1000	
			RES11A16			±1000	
			RES11A20			±1000	
			RES11A25			±1000	
			RES11A30			±1000	
			RES11A40		±85	±1000	
			RES11A50			±1000	
			RES11A90			±1000	
			RES11A00			±1000	
t _{abs}	Absolute tolerance (per resistor) (2)	$(R_x / R_{xnom}) - 1$ (3)			±2	±12	%
	Absolute tolerance span	MAX (t _{absRIN1} , t _{absRG1} , t _{absRIN2} , t _{absRG2}) - MIN (t _{absRIN1} , t _{absRG1} , t _{absRIN2} , t _{absRG2})			±235		ppm
RESISTANCE DRIFT							
	Absolute temperature coefficient of resistance (per resistor) (4)	$(\Delta R_x / R_{x(25^\circ C)}) / \Delta T_A$	T _A = -40°C to +125°C		±18		ppm/°C
	Divider temperature coefficient of resistance (per divider) (4)	$\Delta t_{Dx} / \Delta T_A$	T _A = -40°C to +125°C		-0.2	±2	ppm/°C
TCR	Matching temperature coefficient of resistance (4)	$\Delta t_M / \Delta T_A$	T _A = -40°C to +125°C		±0.05		ppm/°C
	Absolute voltage coefficient of resistance (per resistor) (2) (4)	$\Delta R_{INx} / \Delta V_{RINx}$	V _{RINx} = 0 V to V _{RINx} = 40 V		±0.02		Ω/V
		$\Delta R_{Gx} / (\Delta V_{RGx} \times G_{nom})$	V _{RGx} = 0 V to V _{RGx} = 40 V		±0.02		
	Divider voltage coefficient of resistance (per divider) (4)	$\Delta t_{Dx} / \Delta V_{Dx}$	V _{Dx} = 0 V to V _{Dx} = 40 V		±2		ppm/V
VCR	Matching voltage coefficient of resistance (4)	$(\Delta t_{D2} - \Delta t_{D1}) / \Delta V_{Dx}$	V _{Dx} = 0 V to V _{Dx} = 40 V		±0.5		ppm/V
IMPEDANCE							
C _{IN}	Pin capacitance (4)	RINx to GND/SUB			2.2		pF
		RGx to GND/SUB			1.6		
		RMIDx to GND/SUB			3.3		
	Crosstalk (RMID1 to RMID2) (4)	Substrate biased to GND	f = 10 kHz		-100		dB
			f = 1 MHz		-64		
		Substrate floating	f = 10 kHz		-98		
			f = 1 MHz		-56		

5.5 Electrical Characteristics (continued)

 at $T_A = 25^\circ\text{C}$ (unless otherwise noted)

PARAMETER		TEST CONDITIONS	MIN	TYP	MAX	UNIT
	–3-dB bandwidth ⁽⁴⁾	Substrate biased to GND		35		MHz
		Substrate floating		40		
CMRR	Common-mode rejection ratio ⁽⁵⁾	RES11A10	66.0			dB
		RES11A15	68.0			
		RES11A16	68.5			
		RES11A20	69.5			
		RES11A25	70.9			
		RES11A30	72.0			
		RES11A40	74.0	95.4		
		RES11A50	75.6			
		RES11A90	80.0			
		RES11A00	80.8			

- (1) Relation of R_{G1} / R_{IN1} or R_{G2} / R_{IN2} to nominal ratio.
- (2) Relation of R_{G1} , R_{IN1} , R_{G2} , or R_{IN2} to nominal resistance.
- (3) The specification is the result of this expression, given as a percentage (multiplied by 100%).
- (4) Specified by characterization.
- (5) The specification is the calculated CMRR when implemented in a difference amplifier configuration with an ideal op-amp, such that the only source of common-mode error is the resistor network. See the [Optimizing CMRR in Differential Amplifier Circuits With Precision Matched Resistor Divider Pairs](#) application note for more information. Effects over frequency are not included. If the circuit is configured in an attenuating gain, this result changes accordingly.

5.6 AEC-Q200 Qualification Testing

 at $T_A = 25^\circ\text{C}$ (unless otherwise noted). Compliance is specified by design and/or characterization.

PARAMETER		TEST CONDITIONS	MIN	TYP	MAX	UNIT
ENVIRONMENTAL TEST RATINGS						
	High temperature exposure (storage)	MIL-STD-202 Method 108		PASS		
	Temperature cycling	JESD22-A104		PASS		
	Humidity bias	MIL-STD-202 Method 103		PASS		
	High temperature operating life	MIL-STD-202 Method 108		PASS		
	Mechanical shock	MIL-STD-202, Method 213		PASS		
	Vibration	MIL-STD-202, Method 204		PASS		
	Resistance to soldering heat	MIL-STD-202, Method 210		PASS		
	Solderability	J-STD-002		PASS		
	Flammability	UL-94		PASS		
	Flame retardance	AEC-Q200-01		PASS		

5.7 Typical Characteristics

at $T_A = 25^\circ\text{C}$ (unless otherwise noted)

ADVANCE INFORMATION

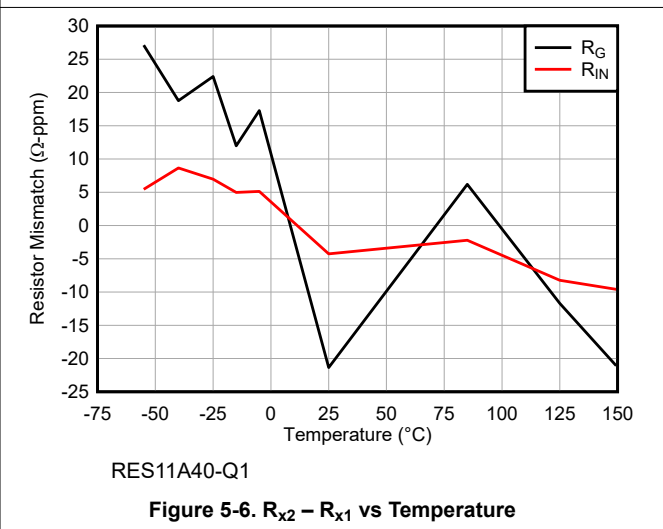
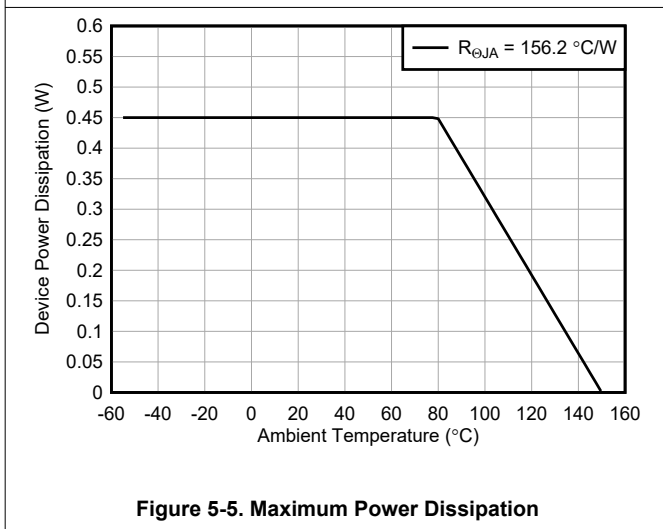
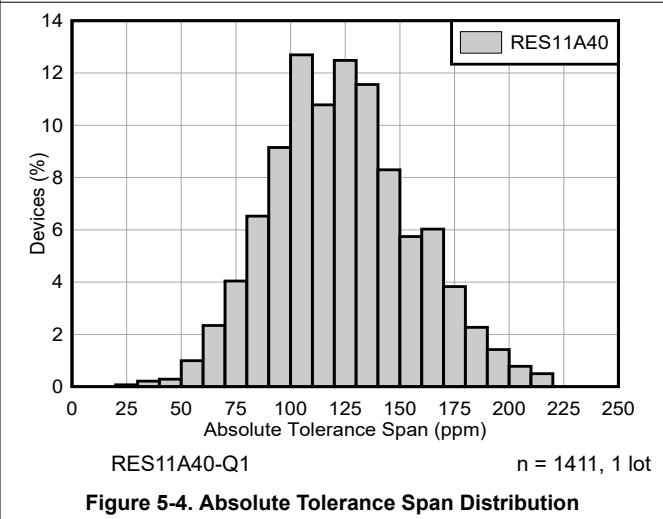
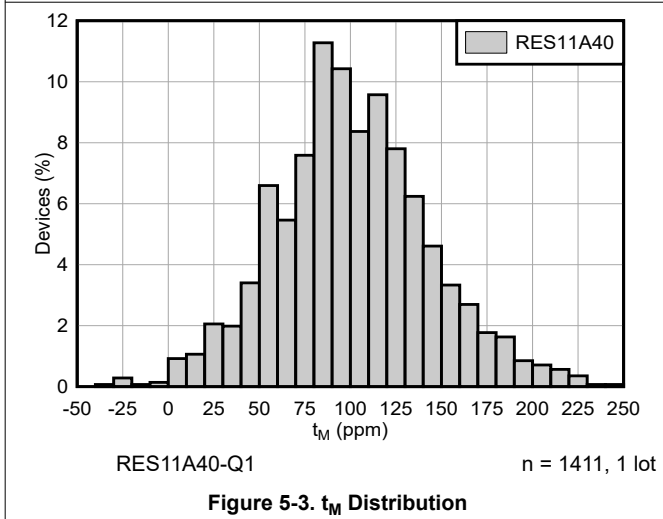
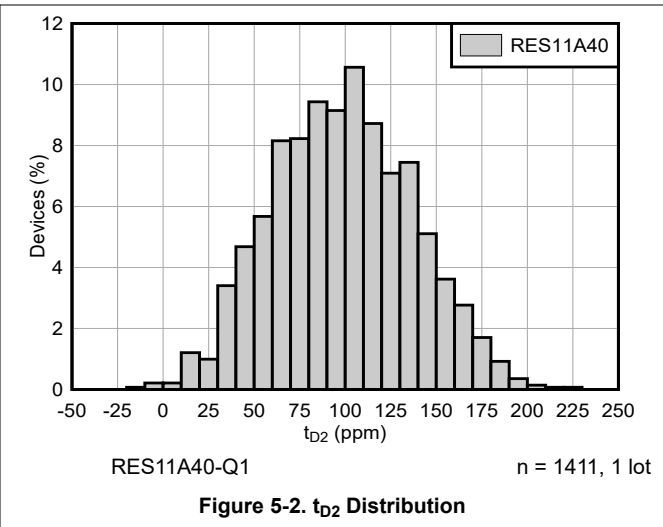
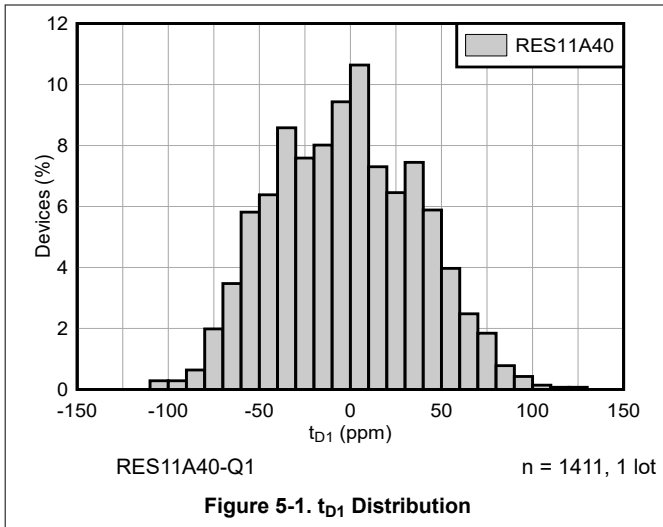

5.7 Typical Characteristics (continued)

at $T_A = 25^\circ\text{C}$ (unless otherwise noted)

ADVANCE INFORMATION

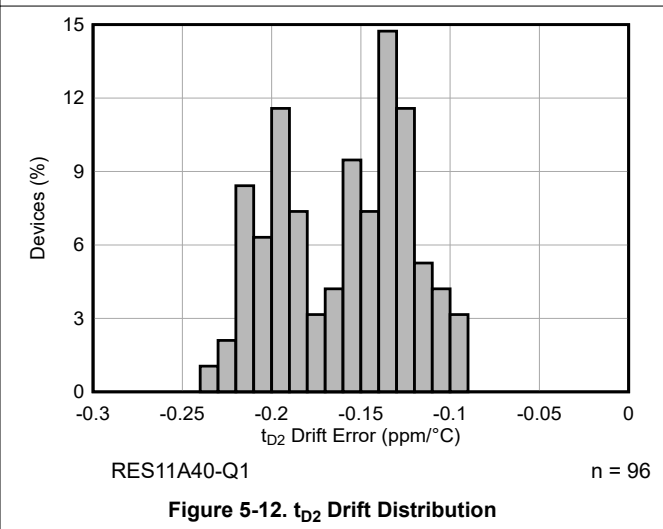
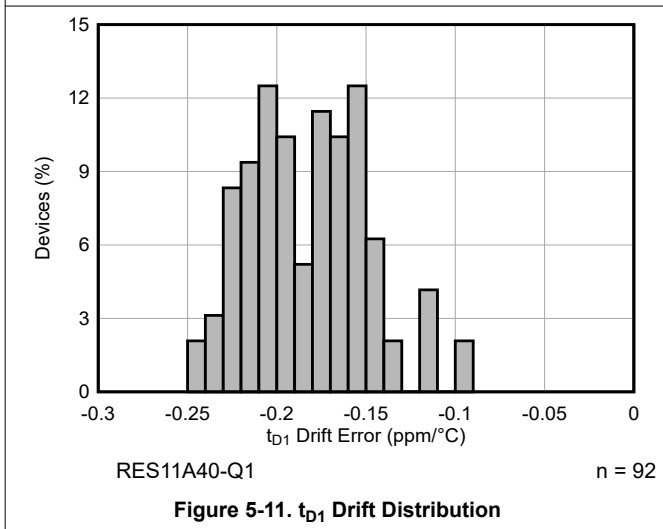
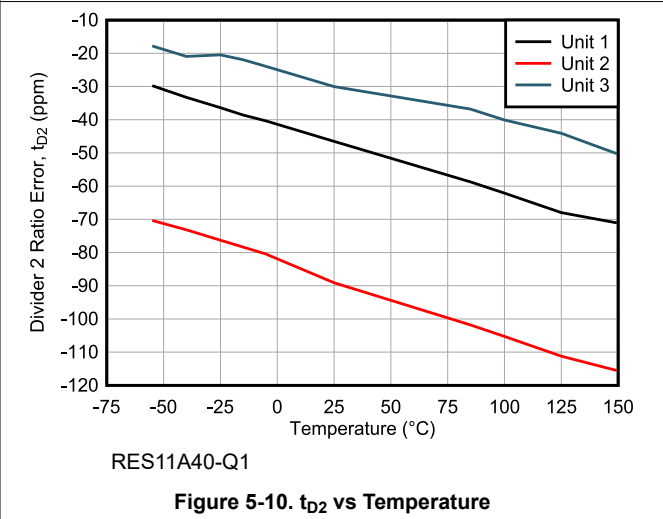
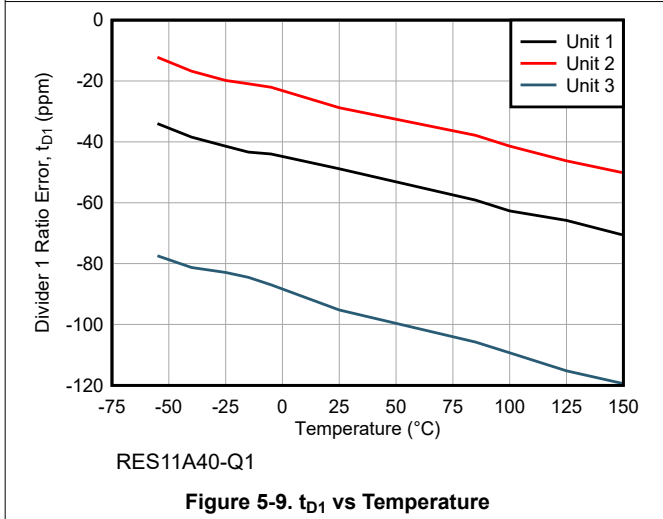
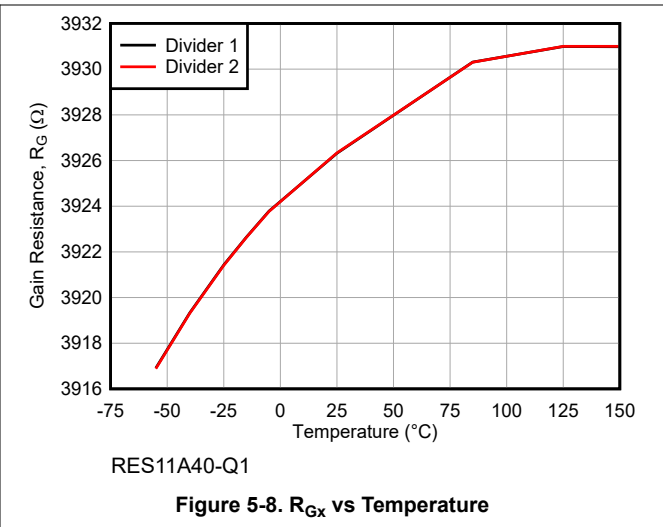
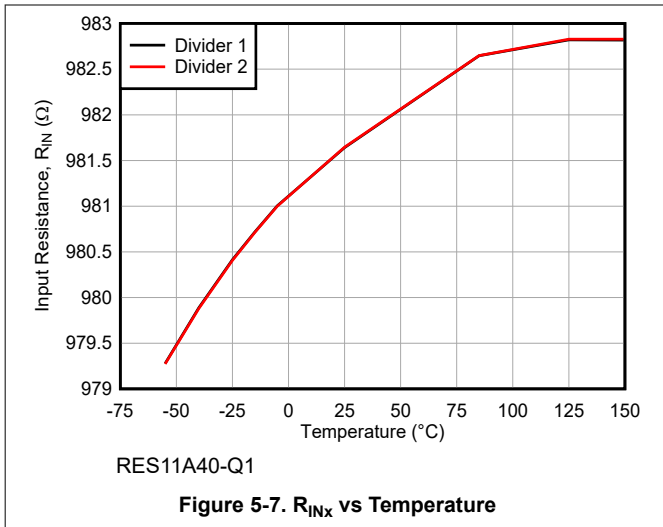

5.7 Typical Characteristics (continued)

at $T_A = 25^\circ\text{C}$ (unless otherwise noted)

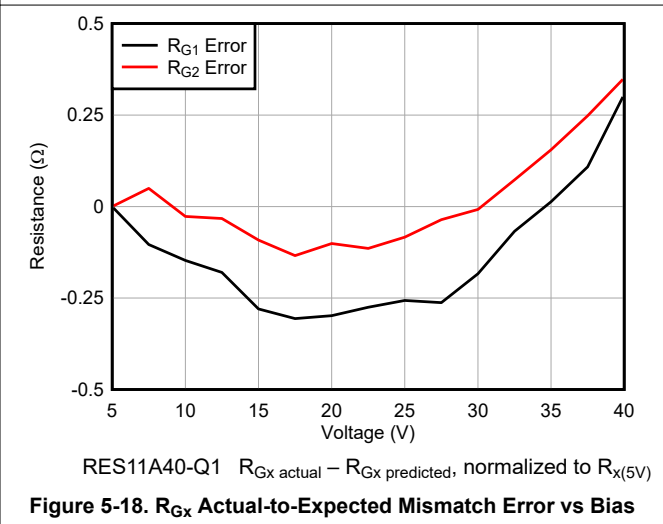
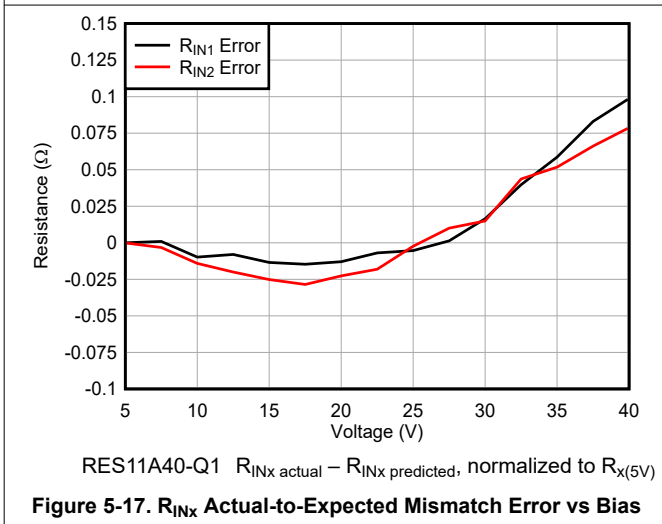
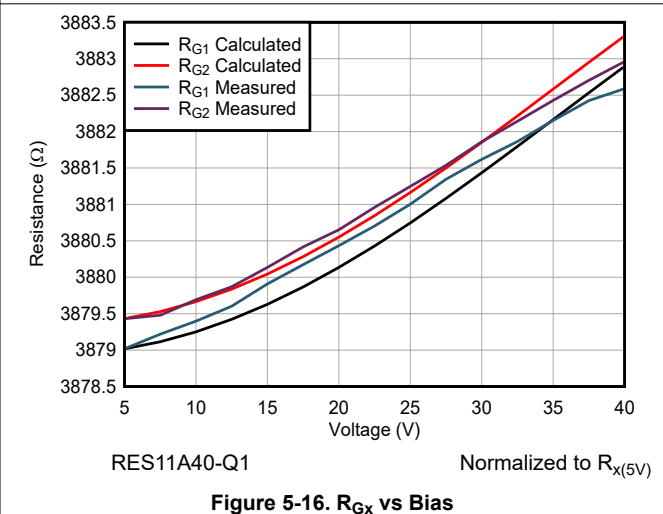
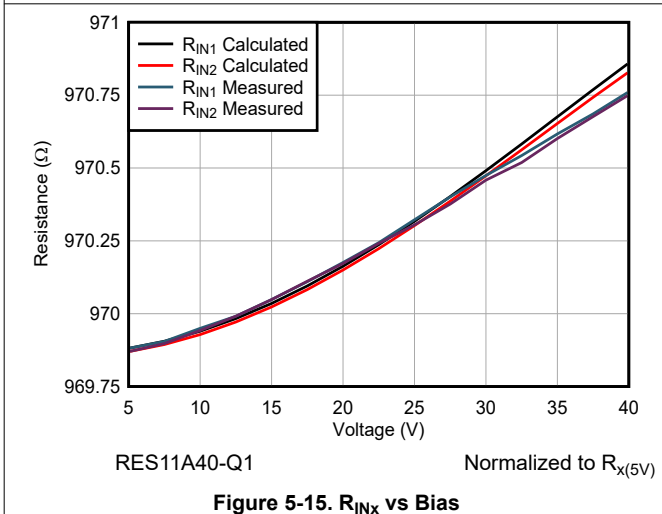
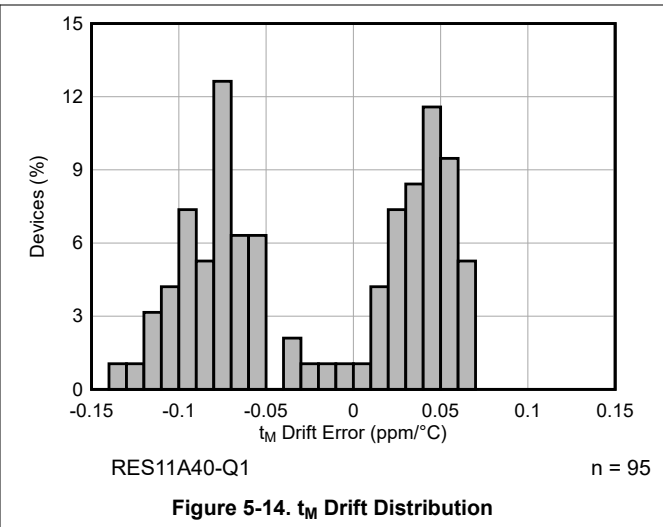
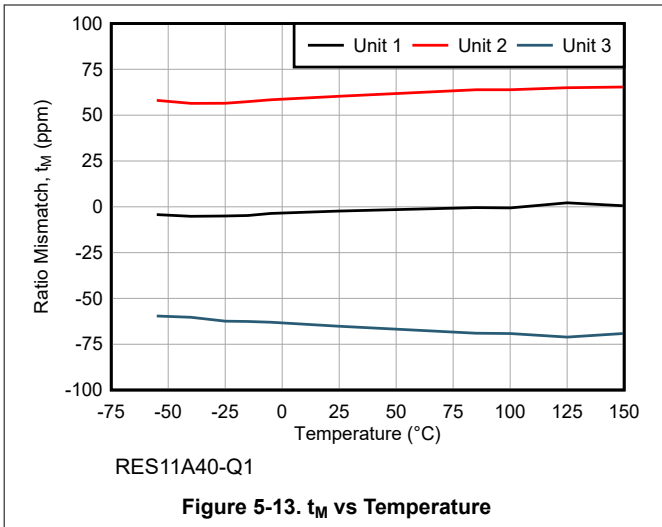

5.7 Typical Characteristics (continued)

at $T_A = 25^\circ\text{C}$ (unless otherwise noted)

ADVANCE INFORMATION

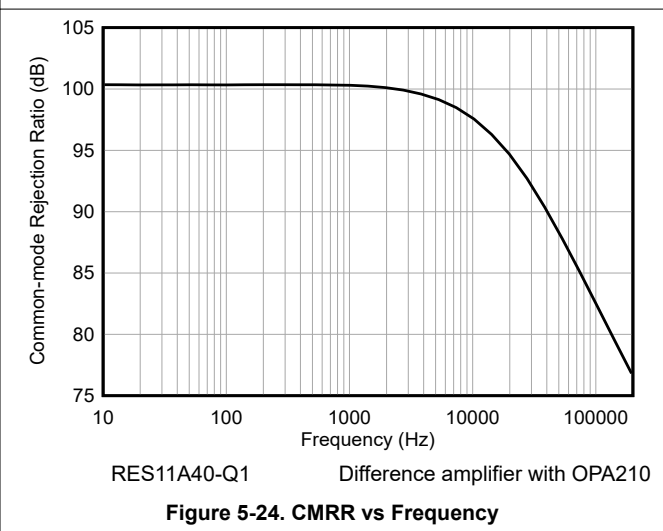
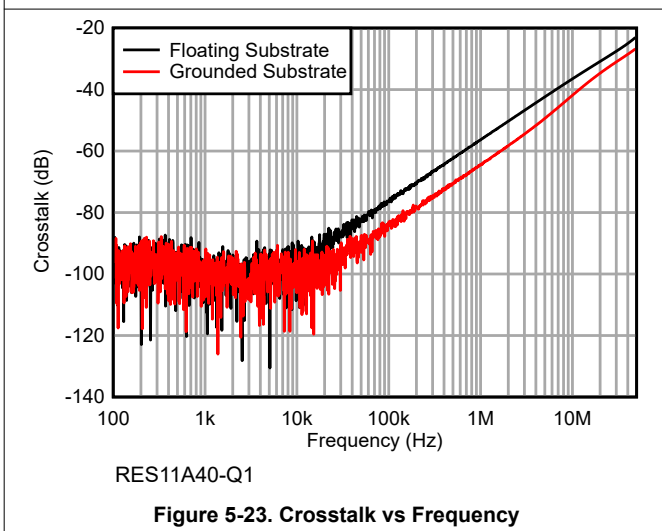
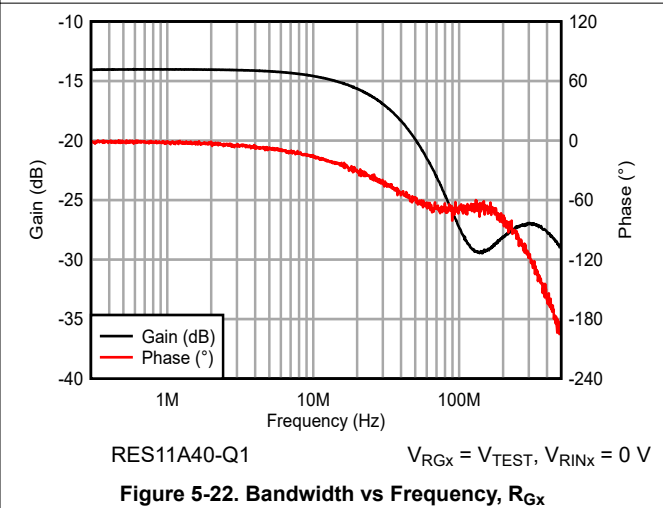
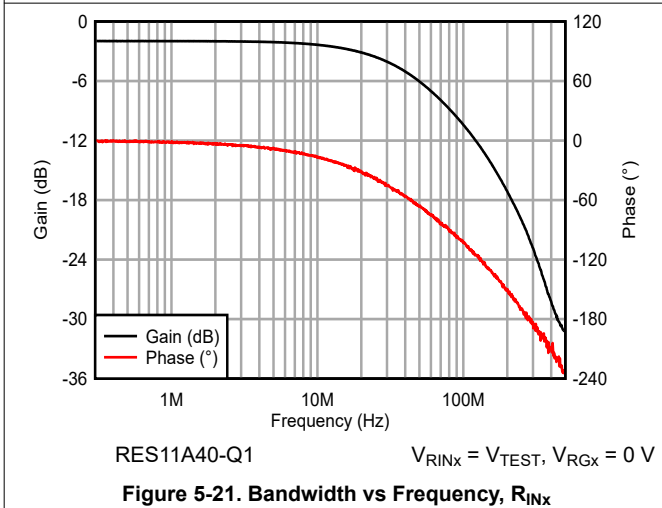
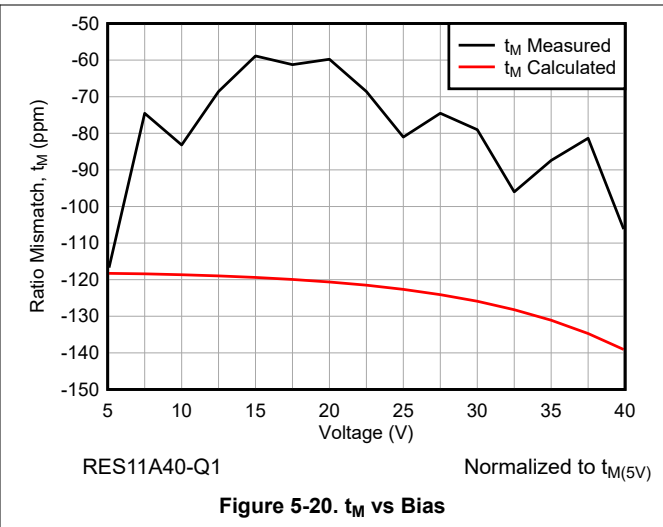
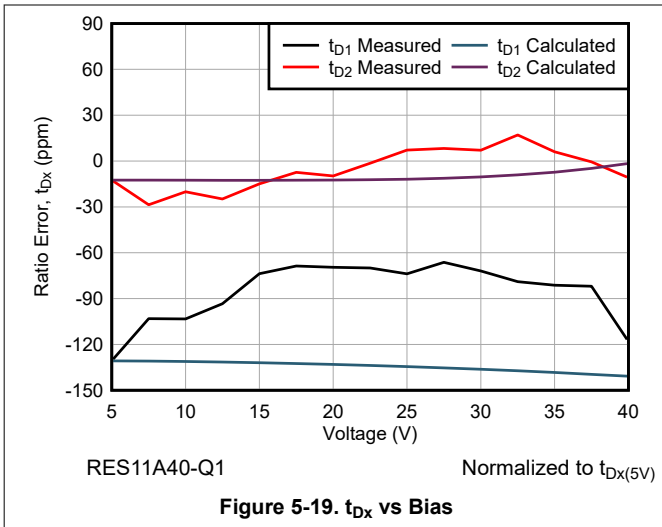

6 Parameter Measurement Information

6.1 DC Measurement Configurations

An example of the circuit configuration used for dc measurements is shown in [Figure 6-1](#). Voltage V_{Dx} refers to the voltage across a given divider, such as V_{D1} for divider 1. Voltage V_{Rx} refers to the voltage across a given resistor, such as V_{RIN1} for R_{IN1} or V_{RG1} for R_{G1} .

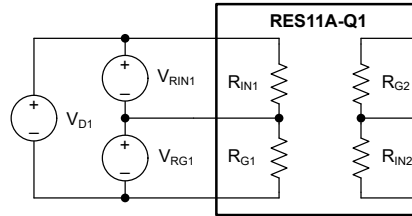

Figure 6-1. DC Measurement Terminology for Divider 1

When the RES11A-Q1 is used to set the gain of an op amp (shown in [Figure 6-2](#)), the ratio of the resistors in a divider sets the amplifier gain according to $G = R_G / R_{IN}$. Discrete-difference-amplifier and instrumentation-amplifier circuits are variations on this ratiometric use case. Typical and maximum parameter values for ratio tolerance (t_{D1} , t_{D2}) are expressed in terms of R_{Gx} / R_{INx} to simplify calculations for these circuits.

However, another valid use case of the RES11A-Q1 is a simple voltage divider, where the midpoint voltage V_{MID} is equal to the input voltage V_D multiplied by $R_G / (R_{IN} + R_G)$, or by $R_{IN} / (R_{IN} + R_G)$ as shown in [Figure 6-3](#). Typical and maximum parameter values for ratio tolerance of these voltage-divider circuits, expressed in terms of $R_{INx} / (R_{INx} + R_{Gx})$, are provided.

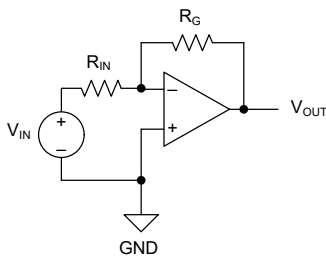

Figure 6-2. Amplifier Gain Circuit

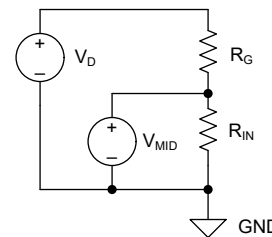

Figure 6-3. Voltage-divider circuit

[Figure 6-4](#) shows the circuit configuration used for CMRR calculations. For an ideal amplifier with no offset and infinite CMRR, the effective circuit CMRR is entirely a function of the matching of the resistors. See [Section 8.1.1.1](#) and the [Optimizing CMRR in Differential Amplifier Circuits With Precision Matched Resistor Divider Pairs](#) application note for more information.

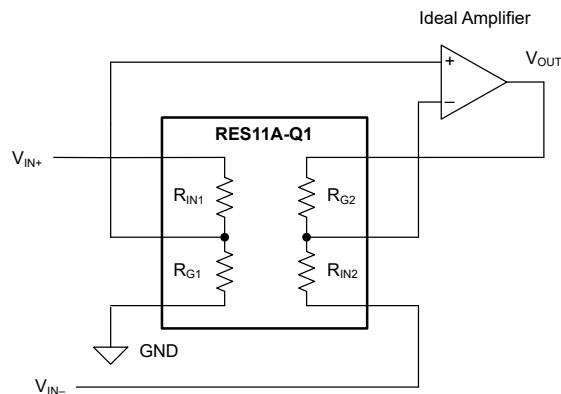

Figure 6-4. CMRR Calculation Reference Schematic

6.2 AC Measurement Configurations

Figure 6-5 shows the circuit configuration used for capacitance measurements. For the RES11A-Q1, a 1-M Ω R_{KNOWN} resistance and 10-pF C_{KNOWN} capacitance are used. The circuit creates an impedance divider; the resulting gain-vs-frequency relationship is used to calculate the parasitic capacitance in parallel with the resistor under test (in this case, R_{IN1}). Calibration with an empty socket is performed to account for board parasitics. The ac source is swept from 100 Hz to 50 MHz.

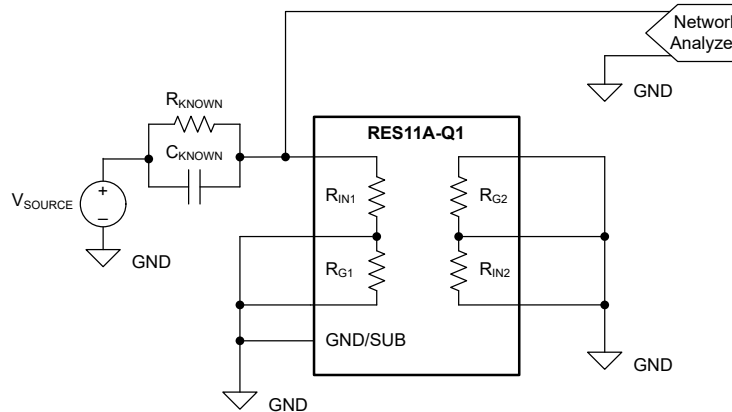

Figure 6-5. Capacitance Measurement Reference Schematic

Figure 6-6 shows the circuit configuration that is used for bandwidth measurements. The ac source is swept from 100 kHz to 500 MHz.

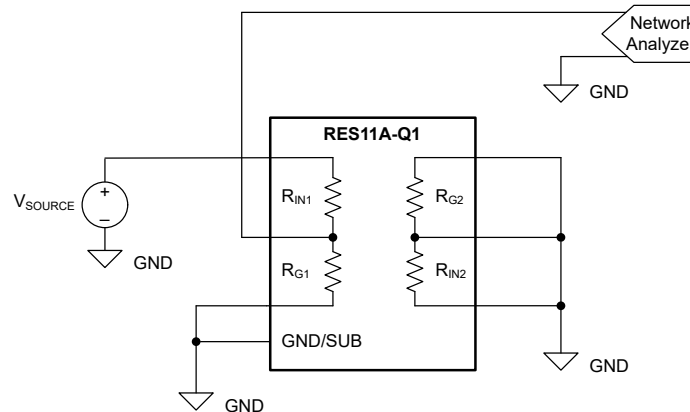

Figure 6-6. Bandwidth Measurement Reference Schematic

Figure 6-7 shows the circuit configuration used for crosstalk measurements. The ac source is swept from 100 Hz to 100 MHz.

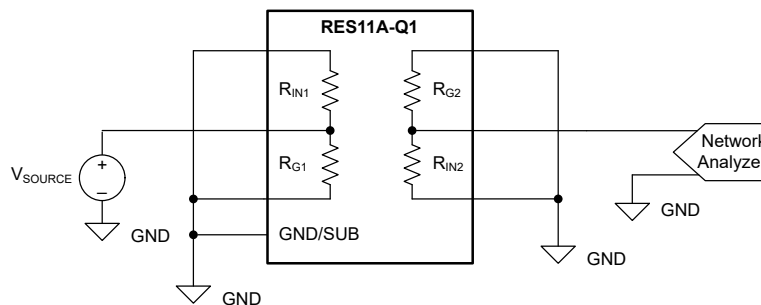

Figure 6-7. Crosstalk Measurement Reference Schematic

7 Detailed Description

7.1 Overview

The RES11A-Q1 consists of four precision thin-film SiCr resistors, arranged to form two matched dividers. The device has two *input* resistors, R_{IN1} and R_{IN2} , both nominally 1 kΩ. The device also has two *gain* resistors, R_{G1} and R_{G2} , with values that depend on the nominal ratio (R_{Gx} / R_{INx}) of the RES11A-Q1 device in question. The resistors are arranged with R_{IN1} and R_{G1} in series to form the first divider, and R_{IN2} and R_{G2} in series to form the second divider. Two GND pins are also provided to bias the device substrate.

7.2 Functional Block Diagram

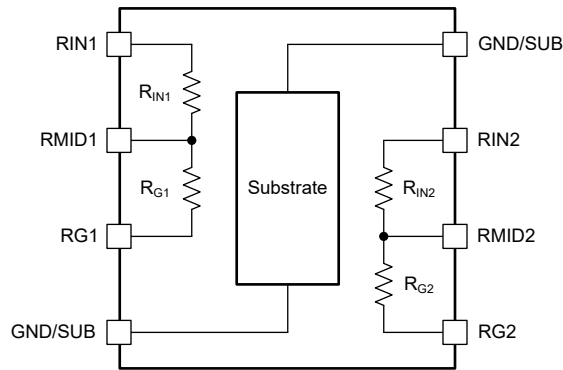

7.3 Feature Description

7.3.1 Ratiometric Matching

The resistors of the RES11A-Q1 are described by the following equations:

$$R_{IN1} = R_{INnom} \times (1+t_{abs}) = R_{INnom} \times (1+t_{RIN1}) \times (1+t_{SiCr}) \quad (1)$$

$$R_{IN2} = R_{INnom} \times (1+t_{RIN2}) \times (1+t_{SiCr}) \quad (2)$$

$$R_{G1} = R_{Gnom} \times (1+t_{RG1}) \times (1+t_{SiCr}) \quad (3)$$

$$R_{G2} = R_{Gnom} \times (1+t_{RG2}) \times (1+t_{SiCr}) \quad (4)$$

R_{INnom} and R_{Gnom} are the nominal values of each resistor. The parameter t_{abs} is an error term that describes the absolute tolerance of the RES11A-Q1 device in question, such that $|t_{abs}| \leq 12\%$. The absolute tolerance is dominated by the variation in the SiCr resistivity, t_{SiCr} . The four resistors of a given RES11A-Q1 are interdigitated and come from the same area of the wafer; therefore, t_{SiCr} is effectively the same for each of the four resistors, although t_{SiCr} varies on a part-to-part basis. The following examples show that when each divider is considered in ratiometric terms, these error terms drop out. Parameter t_{Rx} is an error term that describes the remaining effective tolerance of each resistor of the given RES11A-Q1 device after accounting for the universal t_{SiCr} .

$$\frac{R_{Gx}}{R_{INx}} = \frac{R_{Gnom} \times (1+t_{RGx}) \times (1+t_{SiCr})}{R_{INnom} \times (1+t_{RINx}) \times (1+t_{SiCr})} = \frac{R_{Gnom} \times (1+t_{RGx})}{R_{INnom} \times (1+t_{RINx})} = G_{nom} \times \frac{(1+t_{RGx})}{(1+t_{RINx})} = G_x \quad (5)$$

$$\frac{R_{INx}}{R_{INx} + R_{Gx}} = \frac{R_{INnom} \times (1+t_{RINx}) \times (1+t_{SiCr})}{R_{INnom} \times (1+t_{RINx}) \times (1+t_{SiCr}) + R_{Gnom} \times (1+t_{RGx}) \times (1+t_{SiCr})} = \frac{R_{INnom} \times (1+t_{RINx})}{R_{INnom} \times (1+t_{RINx}) + R_{Gnom} \times (1+t_{RGx})} \quad (6)$$

The RES11A-Q1 is specified with a maximum divider ratio tolerance of 0.05%, meaning that the relationship between the actual divider ratio G_x and nominal ratio G_{nom} of a given divider x is described by the following:

$$G_x = G_{nom} \times (1+t_{Dx}) \quad (7)$$

such that $t_{DX} \leq 0.05\%$. Because any devices that do not meet these criteria are screened out at final test, these equations can be used with [Equation 5](#) to prove the effective bounds of t_{RX} . Therefore, despite the device absolute end-to-end tolerance bounds of $\pm 12\%$, the effective error tolerances of each resistor (for ratiometric applications) are within approximately $\pm 0.025\%$, for the worst-case t_{RX} .

The RES11A-Q1 is specified with a maximum divider matching tolerance of 0.1%, meaning that the relationship between the ratio of divider 1 (G_1) and ratio of divider 2 (G_2) is described by the following:

$$t_M = t_{D2} - t_{D1} = \frac{G_2 - G_1}{G_{nom}} \quad (8)$$

By definition, $|t_M| \leq 0.1\%$. Again, the previous equations relate t_M to the parameters t_{DX} and t_{RX} . As a result of the interdigitation of the two dividers, the actual typical magnitude of t_M is significantly lower than this maximum value, depending on the specific RES11A-Q1 device. This value is used to calculate the common-mode rejection ratio (CMRR) when implementing a difference amplifier circuit. For example, typical t_M for the RES11A40-Q1 is approximately 85 ppm, and the typical CMRR is 95.4 dB.

7.3.2 Ratiometric Drift

The ratiometric matching of the RES11A-Q1 provides a benefit not just for initial conditions, but also when considering parametric drift. The resistors must be considered individually, in absolute terms, and ratiometrically to each other, in matched terms. The absolute temperature coefficients of each resistor show strong correlation, with the coefficient of R_{IN1} comparable to that of R_{IN2} and the coefficient of R_{G1} comparable to that of R_{G2} . The absolute temperature coefficient (in $\Omega/^\circ\text{C}$) of each R_G is approximately G_{nom} times greater than that of the comparable R_{IN} ; hence, the normalized absolute temperature coefficient (in ppm/ $^\circ\text{C}$) of every resistor is about the same.

Because the resistors of the RES11A-Q1 are interdigitated, and occupy a small footprint, the die temperature of the device is effectively common to each of the four resistors. As the temperature changes, each resistor experiences a similar temperature rise. Because the resistors have very similar temperature coefficients, the ratio of R_G to R_{IN} is well preserved. For example, the RES11A40-Q1 has a typical absolute temperature coefficient of approximately 18 ppm/ $^\circ\text{C}$ for R_{IN} or R_G . When considered in ratiometric terms, the typical temperature coefficient of t_{D1} or t_{D2} is -0.2 ppm/ $^\circ\text{C}$, and the temperature coefficient of t_M is 0.05 ppm/ $^\circ\text{C}$.

7.3.3 Predictable Voltage Coefficient

The voltage coefficients of the RES11A-Q1 are almost entirely related to self-heating, where the power dissipated in the device raises the die temperature. As previously mentioned, the commonality of this temperature rise leads to a comparable shift in each resistor, such that the divider ratio is well preserved.

Applying voltage V across resistor or divider R results in the loss of a corresponding power dissipation of $P = V^2 / R$, in the form of heat in the device die. This heat leads to a localized increase in the junction temperature, which in turn causes the same parametric shifts previously discussed in the context of temperature coefficients. TCR is specified as a function of ambient temperature; therefore, use the effective junction-to-ambient thermal resistance to determine the effective temperature rise and calculate the nominal or expected shift.

$$R_{\text{expected}} = \frac{V_R^2}{R} \times R_{\theta JA \text{ effective}} \times TCR_{\text{abs}} \times R \quad (9)$$

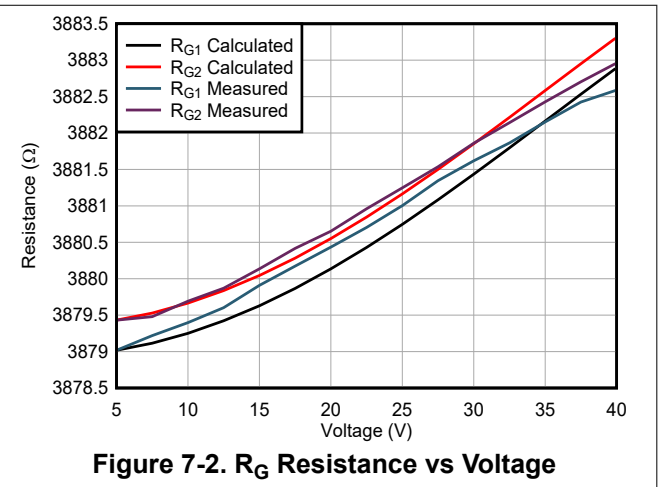
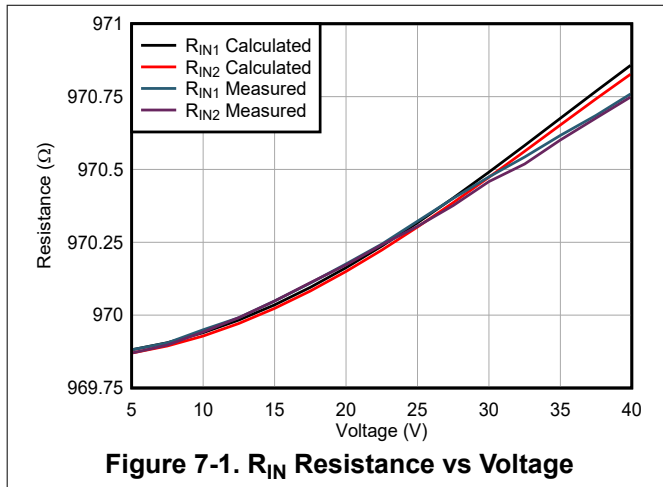

The difference of the expected value of R from the actual value of R describes the actual-to-expected mismatch error of R , due to non-temperature-related effects on the voltage coefficient. Similar to the logarithmic conformity error of a logarithmic amplifier or the integrated nonlinearity error of an ADC, this error describes the deviations of the actual device behavior from the predictable behavior. While the absolute magnitude of the shift varies, the slope or trend is predictable.

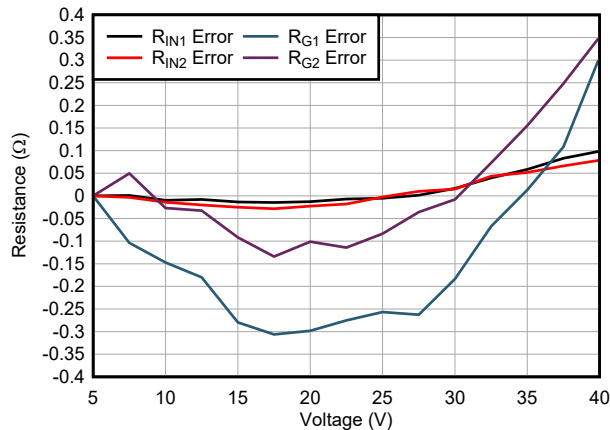

The measured value of R for low bias (measured by sourcing a very small current) is used with the actual value of R to calculate the effective voltage coefficient of resistance.

$$\text{Voltage coefficient } (\Omega/V) = \frac{R_{\text{biased}} - R_{\text{initial}}}{V_{\text{bias}}} \quad (10)$$

This exercise is repeated for each R_x , t_{D1} , t_{D2} , and t_M , to calculate the voltage coefficients associated with each parameter. For example, the RES11A40-Q1 has a typical absolute voltage coefficient of approximately 0.02 Ω/V for R_{IN} or R_G . When considered in ratiometric terms, the typical voltage coefficient of t_{D1} or t_{D2} is 2 ppm/V, and the voltage coefficient of t_M is 0.5 ppm/V.

7.3.4 Ultra-Low Noise

Noise in resistors can be evaluated in two separate regions: low-frequency flicker noise and wideband thermal noise. Flicker, or 1/f noise, is extremely important for systems that require signal gain at frequencies less than 100 Hz. Thermal noise typically dominates in the region greater than 1 kHz, and increases as resistor magnitude increases. Noise is modeled as a voltage source in series with the resistor.

For a resistive divider such as the RES11A-Q1, the thermal noise as measured at the center tap of two resistors, R_{IN} and R_G , is equivalent to the thermal noise of a resistor with value $R_{IN} \parallel R_G$:

$$e_N = \sqrt{(4k_BTR)} \quad (11)$$

where:

- e_N is the thermal noise density in $nV/\sqrt{\text{Hz}}$
- T is the absolute temperature in kelvins (K)
- k_B is the Boltzmann constant, 1.381×10^{-23} J/K
- $R = R_{IN} \parallel R_G$

As an example, for the RES11A40-Q1 at 25°C:

$$e_N = \sqrt{(4k_BTR)} = \sqrt{4 \times 1.38E^{-23} \frac{J}{K} \times 278 K \times (1 k\Omega \parallel 4 k\Omega)} = 3.5 nV/\sqrt{\text{Hz}} \quad (12)$$

7.4 Device Functional Modes

The RES11A-Q1 is typically used with the two independently biased resistor dividers. R_{IN1} and R_{G1} in series form a resistive divider, with R_{IN2} and R_{G2} in series forming another divider. However, the two dividers do not have to be used independently. The resistors can be connected in series or in parallel like any other resistor.

Use one of the two GND pins to bias the part substrate. Connect the substrate to signal ground or a similar low-impedance bias point or plane for best noise rejection. While two GND/SUB connection pins are available on the device, connect only *one* of these to the ground plane. The two GND pins are internally connected through the substrate, which is not intended to conduct significant currents. Connect only *one* GND pin at a time and leave the other pin floating to prevent current return paths from developing through the substrate.

8 Application and Implementation

Note

Information in the following applications sections is not part of the TI component specification, and TI does not warrant its accuracy or completeness. TI's customers are responsible for determining suitability of components for their purposes, as well as validating and testing their design implementation to confirm system functionality.

8.1 Application Information

8.1.1 Discrete Difference Amplifier

The RES11A-Q1 is commonly used to implement a simple difference amplifier. The ratiometric matching between the two resistor dividers improves CMRR performance and gain drift for the circuit, when compared to a similar implementation using unmatched discrete resistors. The basic circuit is shown in [Figure 8-1](#).

$$V_{OUT} = (V_{IN+} - V_{IN-}) \times \left(\frac{R_G}{R_{IN}}\right) + V_{REF} \quad (13)$$

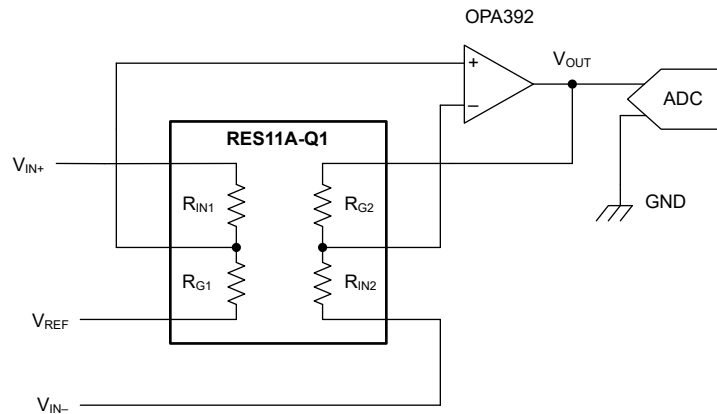

Figure 8-1. Discrete Difference Amplifier Using RES11A-Q1

8.1.1.1 Difference-Amplifier Common-Mode Rejection Analysis

In this simple difference amplifier configuration, the nominal CMRR is calculated as:

$$CMRR = 20 \times \log_{10} \left(\left| \frac{A_D}{A_{CM}} \right| \right) \quad (14)$$

The term A_D is the differential gain of the circuit, and the term A_{CM} is the common-mode gain of the circuit. These are defined as the following:

$$A_D \times \frac{V_{OUT}}{V_D} = 0.5 \times \frac{\left(\frac{R_{G1}}{R_{G1} + R_{IN1}}\right) + \left(\frac{R_{G2}}{R_{G2} + R_{IN2}}\right)}{\left(\frac{R_{IN2}}{R_{G2} + R_{IN2}}\right)} \quad (15)$$

$$A_{CM} = \frac{V_{OUT}}{V_{CM}} = \frac{\left(\frac{R_{G1}}{R_{G1} + R_{IN1}}\right) - \left(\frac{R_{G2}}{R_{G2} + R_{IN2}}\right)}{\left(\frac{R_{IN2}}{R_{G2} + R_{IN2}}\right)} \quad (16)$$

Therefore,

$$\text{CMRR} = 20 \times \log_{10} \left(\left| 2 \times \frac{R_{G1} \times (R_{IN2} + R_{G2}) - R_{G2} \times (R_{IN1} + R_{G1})}{R_{G1} \times (R_{IN2} + R_{G2}) + R_{G2} \times (R_{IN1} + R_{G1})} \right| \right) \quad (17)$$

When this expression is evaluated with the definitions given in [Section 7.3.1](#), assuming the worst-case scenario of the most unbalanced divider matching possible,

$$\text{CMRR} = 20 \times \log_{10} \left(\left| \frac{G_{\text{nom}} + 1 + t_{R_X}^2 (1 - G_{\text{nom}})}{4 \times t_{R_X}} \right| \right) \quad (18)$$

Because $t_{R_X}^2 \ll 1$, the worst-case CMRR is approximated as

$$\text{CMRR} = 20 \times \log_{10} \left(\left| \frac{G_{\text{nom}} + 1}{4 \times t_{R_X}} \right| \right) \quad (19)$$

By definition, the parameter t_M describes the effective error that is otherwise equivalent to $4 \times t_x$ for an unmatched divider network, and so the maximum value of t_M can be used to calculate the same worst-case result. Likewise, the typical value of t_M can be used to approximate the typical CMRR.

$$\text{CMRR} = 20 \times \log_{10} \left(\left| \frac{G_{\text{nom}} + 1}{t_M} \right| \right) \quad (20)$$

For example, the worst-case CMRR for a RES11A40-Q1 device with $G = 4$ is approximately 74.0 dB, with a typical CMRR of approximately 95.4 dB. In comparison, implementation of a comparable $G = 4$ difference amplifier with unmatched 0.1%-tolerance resistors results in a worst-case CMRR of approximately 62 dB.

In a difference amplifier configuration, the CMRR of the op amp contributes error as well. The op-amp CMRR is considered in parallel with the CMRR of the resistor network, as per the following equation:

$$\frac{1}{\text{CMRR}_{\text{TOTAL}}} = \frac{1}{\text{CMRR}_{\text{AMP}}} + \frac{1}{\text{CMRR}_{\text{RESISTORS}}} \quad (21)$$

Additional mismatches in the divider end-to-end resistances reduce the effective CMRR of a difference amplifier. While the low absolute tolerance span of the RES11A-Q1 (235 ppm typical) helps reduce these concerns, parasitic trace resistances can lead to additional mismatches that impact the CMRR specs. Bench results from a difference amplifier implementation of the RES11A40-Q1 and the OPA210 are presented for various deliberate input-impedance mismatches.

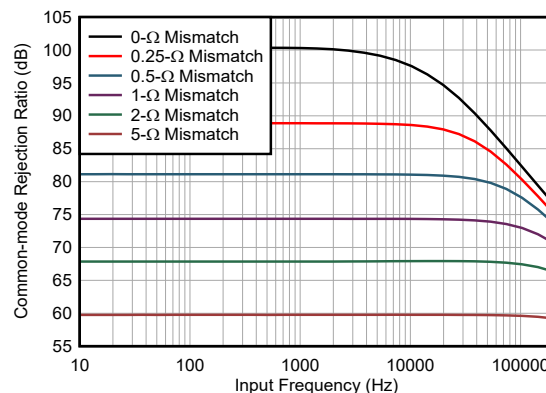

Figure 8-2. Effect of Input Impedance Mismatch on Common-mode Rejection Ratio

8.1.2 Discrete Instrumentation Amplifiers

The RES11A-Q1 can be used in conjunction with a dual-channel operational amplifier to implement a discrete instrumentation amplifier (INA). The ratiometric matching between the two resistor dividers improves CMRR performance for the circuit when compared to a similar implementation using unmatched discrete resistors,

and results in better overtemperature and overaging gain drift characteristics. INAs are often used instead of difference amplifiers when high input impedance and low bias currents are needed, such as when measuring bridge sensors.

Discrete INAs are often configured as a differential-input differential-output circuit as shown in Figure 8-3. While not shown, if needed, use an additional discrete difference amplifier stage (requiring a second RES11A-Q1 and another op-amp channel) to convert the differential output voltage to a single-ended voltage (for example, when driving a single-ended ADC). This extra stage can also add an additional offset and provide additional gain, effectively mimicking the common three-amplifier INA architecture.

$$V_{OUT+} - V_{OUT-} = (V_{IN+} - V_{IN-}) \times \left(1 + \frac{R_G}{R_{IN}} \right) \quad (22)$$

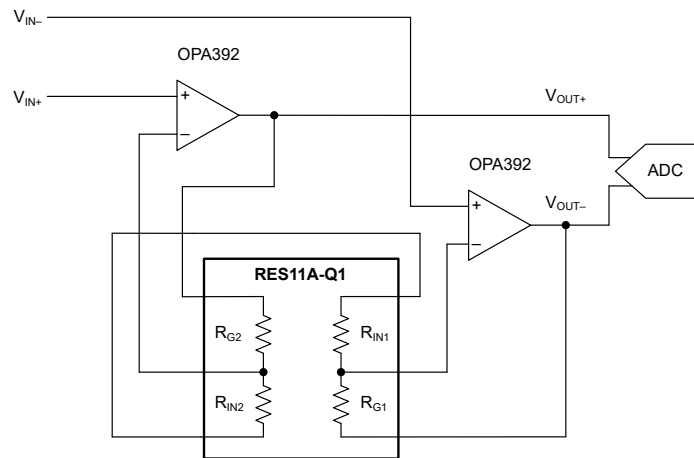

Figure 8-3. Differential-Input, Differential-Output Instrumentation Amplifier Using the RES11A-Q1

Less commonly, a discrete INA can be implemented as a differential-input, single-ended output circuit as shown in Figure 8-4. This topology maintains high input impedances, allows an offset to be applied, and gives a single-ended output without requiring a third amplifier channel. The offset must be driven by a low-impedance source, such as a reference buffer. When designing a discrete INA, carefully consider the output swing and input common-mode range limitations of the amplifiers used in the circuit design process.

$$V_{OUT} = (V_{IN+} - V_{IN-}) \times \left(1 + \frac{R_G}{R_{IN}} \right) + V_{REF} \quad (23)$$

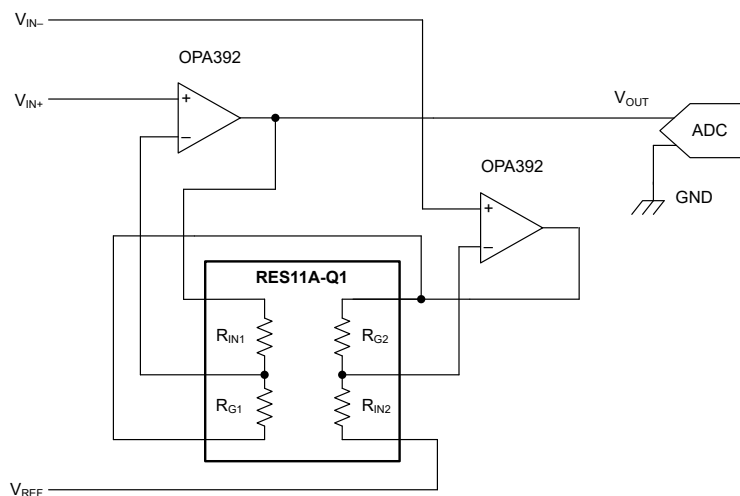

Figure 8-4. Differential-Input, Single-Ended Output Instrumentation Amplifier Using the RES11A-Q1

8.1.2.1 Instrumentation Amplifier Common-Mode Rejection Analysis

The differential-input, differential-output instrumentation amplifier shown in Figure 8-3 has a common-mode gain of $A_{CM} = 1$ V/V. The differential gain is described by the following (assuming an ideal amplifier):

$$A_D = \frac{R_{G1} + R_{G2}}{R_{IN1} + R_{IN2}} + 1 = G_{nom} \times \frac{(1 \pm t_{RG1}) + (1 \pm t_{RG2})}{(1 \pm t_{RIN1}) + (1 \pm t_{RIN2})} + 1 \quad (24)$$

Because the worst-case-stage CMRR occurs when the differential gain is lowest, and the common-mode gain is unity, the minimum CMRR is evaluated as:

$$\frac{A_D}{A_{CM}} = G_{nom} \times \frac{(1 - t_{RG1}) + (1 - t_{RG2})}{(1 + t_{RIN1}) + (1 + t_{RIN2})} + 1 = G_{nom} \times \frac{1.9995}{2.0005} + 1 \quad (25)$$

For example, for an instrumentation amplifier with RES11A90-Q1, the worst-case CMRR is:

$$\frac{A_D}{A_{CM}} = G_{nom} \times \frac{(1 - t_{RG1}) + (1 - t_{RG2})}{(1 + t_{RIN1}) + (1 + t_{RIN2})} + 1 = 9 \text{ V/V} \times \frac{1.9995}{2.0005} + 1 = 9.9955 \text{ V/V} \quad (26)$$

8.1.3 Fully Differential Amplifier

The RES11A-Q1 can be used to set the gain of a fully differential amplifier, such as the THP210. The ratiometric matching between the two resistor dividers leads to improved gain matching and CMRR performance for the circuit, when compared to a similar implementation using unmatched discrete resistors.

Figure 8-5 shows a generic schematic representation of a fully differential amplifier driving a differential ADC, with a RES11A-Q1 used to set the amplifier gain.

$$V_{OUT+} - V_{OUT-} = (V_{IN+} - V_{IN-}) \times \left(\frac{R_G}{R_{IN}} \right) \quad (27)$$

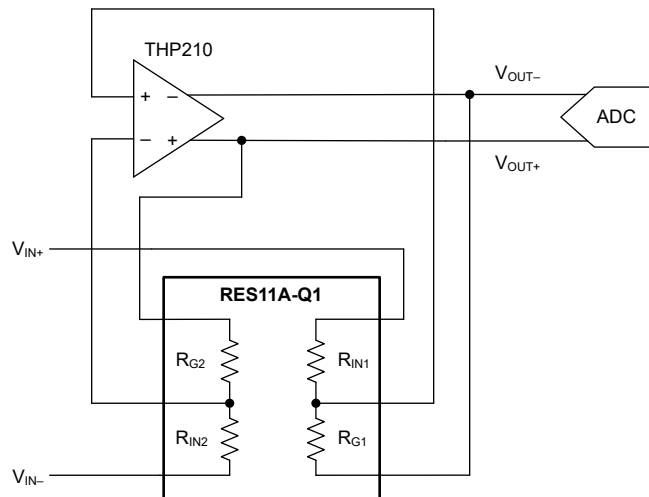

Figure 8-5. Fully-differential Amplifier Gain Setting Using RES11A-Q1

8.2 Typical Application

8.2.1 Common-Mode Shifting Input Stage

The RES11A-Q1 can be used to implement a common-mode attenuator at the high-impedance inputs of an instrumentation amplifier (INA). This configuration extends the usable signal range, so long as the maximum differential voltage limitation of each resistor divider is respected.

Figure 8-6 shows an example of a high-side current-sense circuit where a differential voltage, V_{SHUNT} , develops across a sense resistor with an undesirably high common-mode voltage V_{CM} . V_{REF} is used to shift input common-mode voltages V_{MID1} and V_{MID2} to levels within the specified input common-mode range of the INA. The amplifier output, V_{OUT} , is a scaled function of V_{SHUNT} , such that nominally:

$$V_{OUT} = V_{SHUNT} \times \left(\frac{R_{IN}}{R_G + R_{IN} + R_{EQUIV}} \right) \quad (28)$$

V_{OUT} can be gained up further by the INA stage, to make maximal use of the effective resolution of a downstream ADC. In practice R_{EQUIV} is optional; however, if $R_{EQUIV} = R_{SHUNT}$, this resistance equalizes the nominal impedance between V_{CM} and each of the INA high-impedance inputs, thus improving CMRR performance. Select an INA with input bias currents I_{B1} and $I_{B2} \ll I_{STATIC1}$ and $I_{STATIC2}$, such as the [INA333](#) or [INA823](#). Select a RES11A-Q1 device with a sufficiently high divider series resistance so that $I_{STATIC1}$ and $I_{STATIC2} \ll I_{LOAD}$.

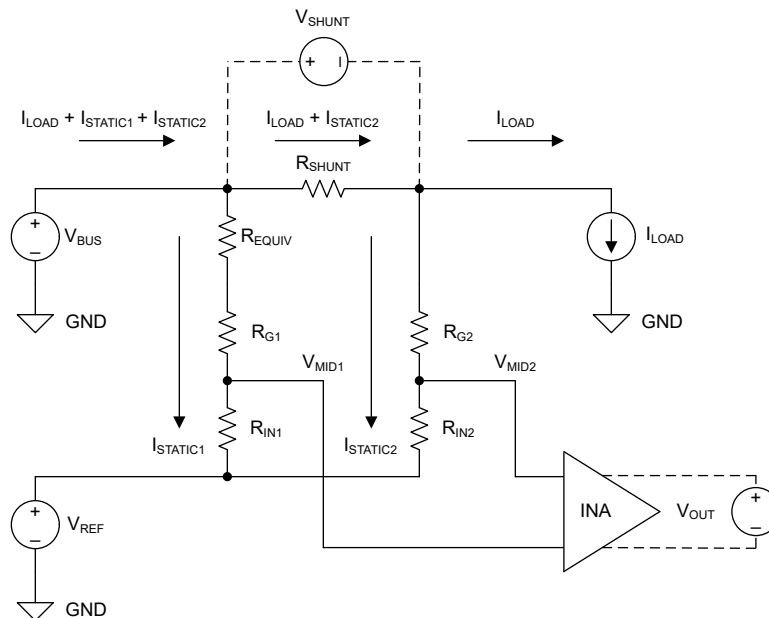

Figure 8-6. RES11A-Q1 Common-Mode Shifting Circuit

To achieve a desired nominal input common-mode voltage, $V_{MID1TARGET}$, set V_{REF} as follows:

$$V_{REF} = V_{MID1TARGET} \times \left(\frac{R_G + R_{IN} + R_{EQUIV}}{R_G + R_{EQUIV}} \right) - V_{CM} \times \left(\frac{R_G + R_{IN} + R_{EQUIV}}{R_G + R_{EQUIV}} - 1 \right) \quad (29)$$

8.2.1.1 Design Requirements

Consider a level-shifting application where a high-side current shunt measurement from an 18-V supply rail must be measured by a 3.3-V amplifier and ADC.

PARAMETER	DESIGN GOAL
Input V_{BUS}	18 V
I_{LOAD}	300 mA (maximum)
R_{SHUNT}	1 Ω
ADC full-scale range (target V_{OUT})	3.3 V
Possible V_{REF} voltages	3.3 V, 0 V

8.2.1.2 Detailed Design Procedure

The design parameters are used with the aforementioned equations to select a nominal target G . When the possible V_{REF} voltages available in the system are considered, $V_{REF} = 0$ V with $G = 9$ is found to result in a V_{MID1} value of 1.8 V, well within the input common-mode range of a 3.3-V rail-to-rail amplifier such as the [OPA392](#). When the corresponding RES11A90-Q1 is employed, the loss terms $I_{STATIC1}$ and $I_{STATIC2}$ are nominally 1.80 mA and 1.77 mA for $I_{LOAD} = 300$ mA, resulting in an effective floor of 1.77 mA for I_{LOAD} . For simplicity, the error contributions of the INA stage V_{OS} and I_B are ignored.

For the INA stage, an integrated TI instrumentation amplifier (IA) can be used. Alternatively, a discrete approach can be implemented using another RES11A-Q1 device or devices, and one or more op amps. For this example, an IA stage is constructed with two channels of a [OPA4392](#) and a second RES11A90-Q1 (R_{IN3} , R_{G3} , R_{IN4} , and R_{G4}). This stage is in turn cascaded with a difference amplifier stage, constructed with the third amplifier channel and a RES11A00-Q1 (R_{IN5} , R_{G5} , R_{IN6} , and R_{G6}). The level-shifting stage gain of 10^{-1} , multiplied by the instrumentation amplifier stage gain of 10, results in an effective unity-gain transfer function for V_{SHUNT} . Therefore, the differential output voltage for this stage is approximately 0.3 V, with amplifier outputs of 1.936 V and 1.634 V. After the final difference amplifier stage gain of $G = 10$, the common-mode voltage drops out and the maximum value of the resulting V_{OUT} is nominally 3.0 V, compatible with a single-ended 3.3-V ADC such as the [ADS7046](#). If desired, the fourth channel of the OPA4392 can be used to buffer this output signal and serve as a dedicated ADC driver.

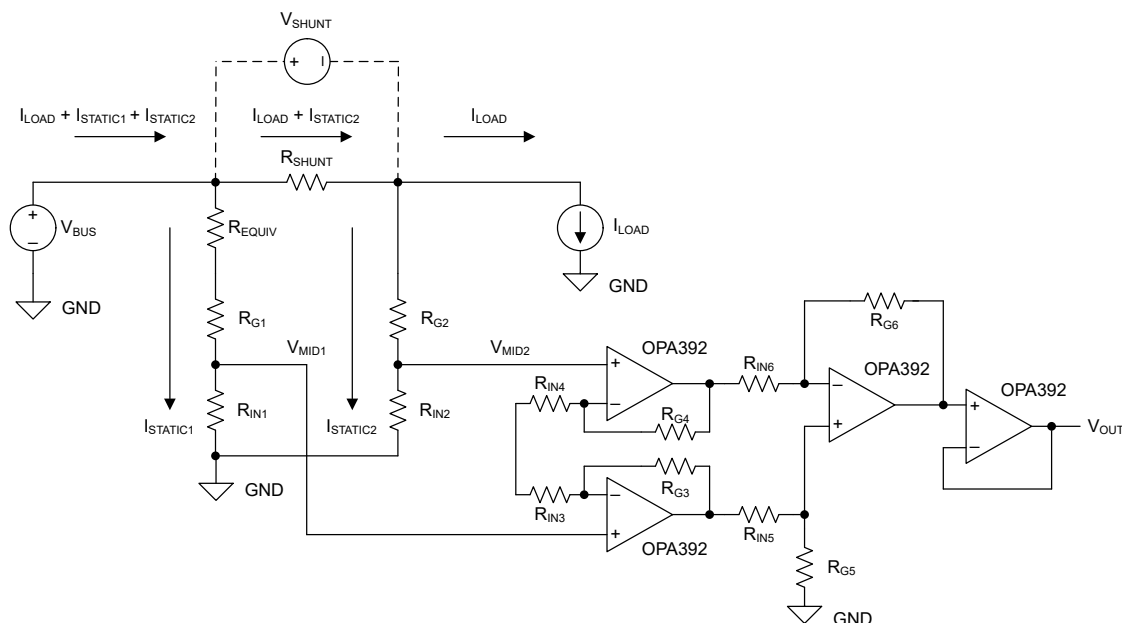

Figure 8-7. High-Side Current Shunt Common-Mode Shifting Circuit

8.2.1.3 Application Curves

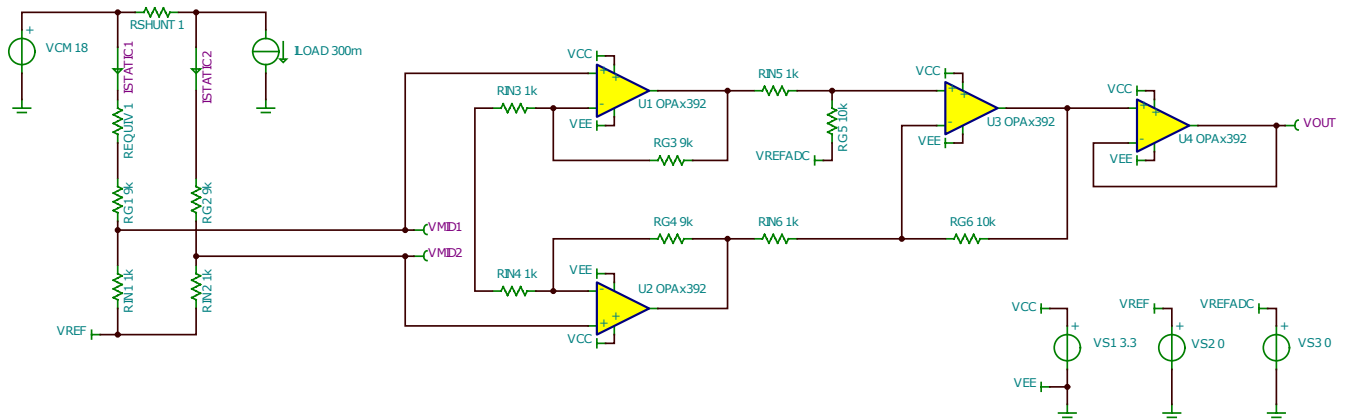

Figure 8-8. Circuit Model in TINA-TI

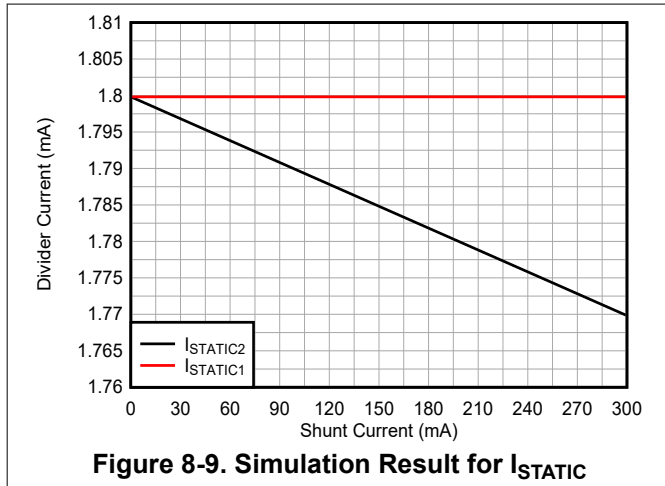

Figure 8-9. Simulation Result for ISTATIC

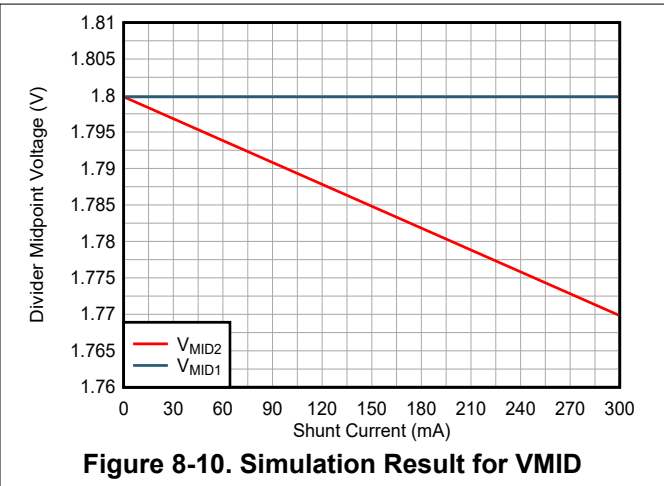

Figure 8-10. Simulation Result for VMID

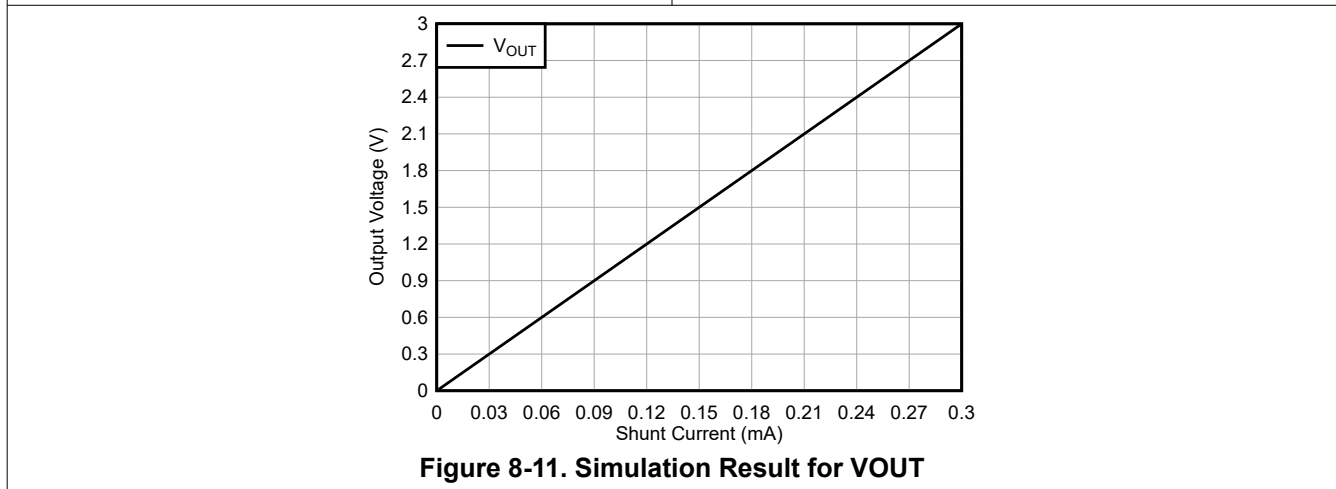

Figure 8-11. Simulation Result for VOUT

8.3 Power Supply Recommendations

The ratio of a given RES11A-Q1 device dictates the maximum differential voltage rating for the resistor dividers of the device. See the *Absolute Maximum Ratings* and *Recommended Operating Conditions* for device-specific values under transient and sustained bias conditions, respectively. See [Figure 8-12](#) for approximate values, assuming $R_{\theta JA} = 156.2^{\circ}\text{C}/\text{W}$ and that both dividers are biased to the same dc voltage at the same time. Keep T_J less than the absolute maximum rating of 150°C .

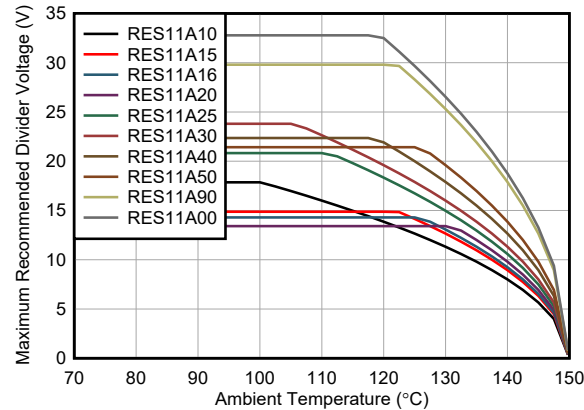

Figure 8-12. Maximum Recommended Divider Voltage vs Ambient Temperature

8.4 Layout

8.4.1 Layout Guidelines

For best operational performance of the device, use good printed-circuit board (PCB) layout practices, including:

- Reduce parasitic coupling by running input traces as far away from supply or output traces as possible. If these traces cannot be kept separate, crossing the sensitive trace perpendicular is much better as opposed to in parallel with the noisy trace.
- Place the external components as close to the device as possible.
- Keep the length of input traces as short as possible. Always remember that the input traces are the most sensitive part of the circuit. For differential circuits, match the length of the input traces as best possible.
- Keep high impedance input signals away from noisy traces.
- Make sure system supply voltages are adequately filtered.
- Clean the PCB following board assembly for best performance.
- Any precision integrated circuit can experience performance shifts resulting from moisture ingress into the plastic package. Following any aqueous PCB cleaning process, bake the PCB assembly to remove moisture introduced into the device packaging during the cleaning process. A low temperature, post-cleaning bake at 85°C for 30 minutes is sufficient for most circumstances.
- Only connect one of the two GND/SUB pins to the ground plane, to prevent the formation of current return paths through the device substrate. Float the other GND/SUB pin.

8.4.2 Layout Examples

In the following examples, the RES11A-Q1 is shown with a VSSOP amplifier and 0402-size decoupling capacitors.

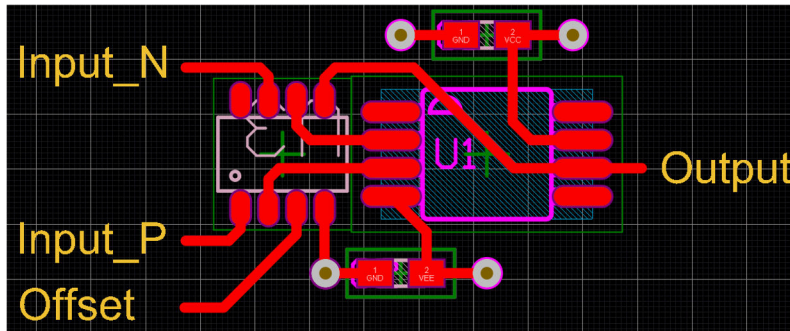

Figure 8-13. Single-Layer Difference Amplifier Implementation

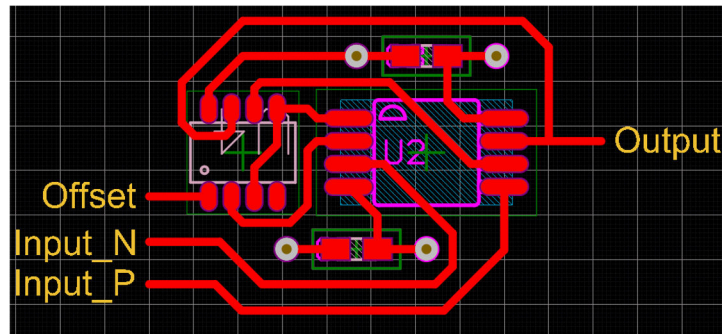

Figure 8-14. Single-Layer Instrumentation Amplifier Implementation

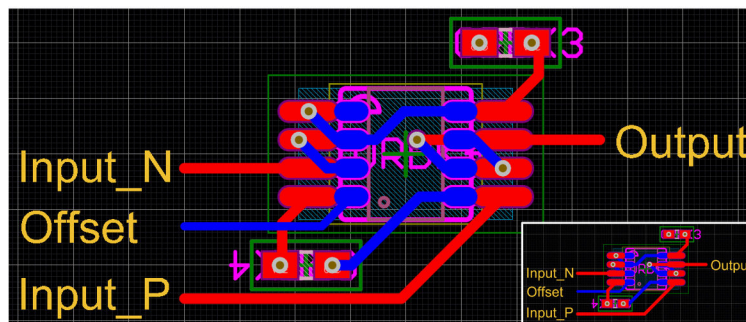

Figure 8-15. Front-and-Back Instrumentation Amplifier Implementation

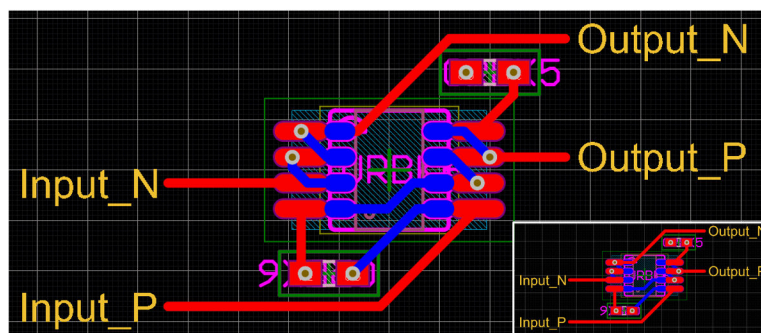

Figure 8-16. Front-and-Back, Differential-Output Instrumentation Amplifier Implementation

For Figure 8-17, two RES11A-Q1 devices (bottom side) and one dual-channel op-amp (top side) are used.

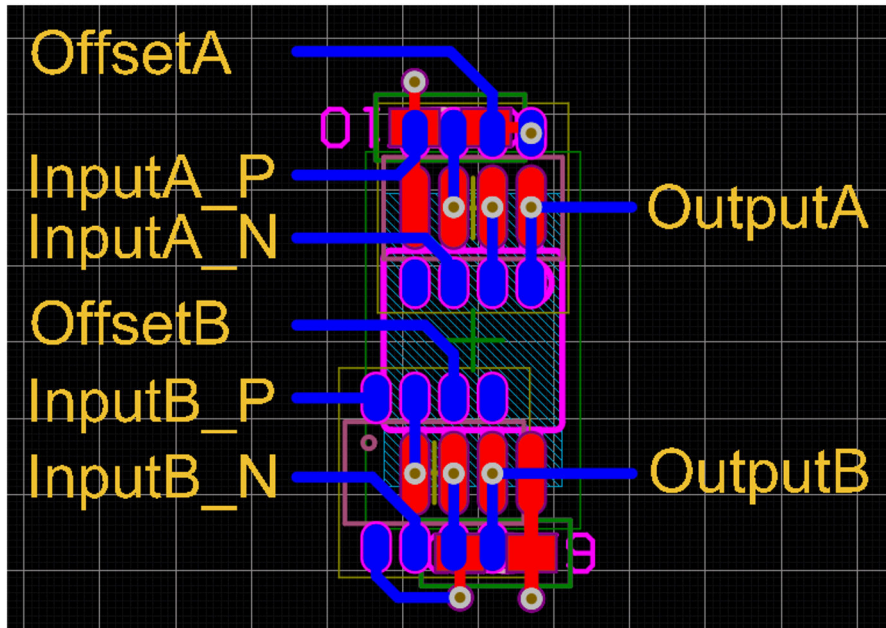

Figure 8-17. Front-and-Back Dual Difference Amplifiers Implementation

9 Device and Documentation Support

9.1 Device Support

9.1.1 Development Support

9.1.1.1 PSpice® for TI

PSpice® for TI is a design and simulation environment that helps evaluate performance of analog circuits. Create subsystem designs and prototype solutions before committing to layout and fabrication, reducing development cost and time to market.

9.1.1.2 TINA-TI™ Simulation Software (Free Download)

TINA-TI™ simulation software is a simple, powerful, and easy-to-use circuit simulation program based on a SPICE engine. TINA-TI simulation software is a free, fully-functional version of the TINA™ software, preloaded with a library of macromodels, in addition to a range of both passive and active models. TINA-TI simulation software provides all the conventional dc, transient, and frequency domain analysis of SPICE, as well as additional design capabilities.

Available as a [free download](#) from the [Design tools and simulation](#) web page, TINA-TI simulation software offers extensive post-processing capability that allows users to format results in a variety of ways. Virtual instruments offer the ability to select input waveforms and probe circuit nodes, voltages, and waveforms, creating a dynamic quick-start tool.

Note

These files require that either the TINA software or TINA-TI software be installed. Download the free TINA-TI simulation software from the [TINA-TI™ software folder](#).

9.1.1.3 TI Reference Designs

TI reference designs are analog solutions created by TI's precision analog applications experts. TI reference designs offer the theory of operation, component selection, simulation, complete PCB schematic and layout, bill of materials, and measured performance of many useful circuits. TI reference designs are available online at <https://www.ti.com/reference-designs>.

9.1.1.4 Filter Design Tool

The [filter design tool](#) is a simple, powerful, and easy-to-use active filter design program. The filter design tool allows the user to create optimized filter designs using a selection of TI operational amplifiers and passive components from TI's vendor partners.

Available as a web-based tool from the [Design tools and simulation](#) web page, the [filter design tool](#) allows the user to design, optimize, and simulate complete multistage active filter solutions within minutes.

9.2 Documentation Support

9.2.1 Related Documentation

For related documentation see the following:

- Texas Instruments, [Optimizing CMRR in Differential Amplifier Circuits With Precision Matched Resistor Divider Pairs application note](#)
- Texas Instruments, [THP210 Ultra-Low Offset, High-Voltage, Low-Noise, Precision, Fully-Differential Amplifier data sheet](#)
- Texas Instruments, [OPAx392 Precision, Low-Offset-Voltage, Low-Noise, Low-Input-Bias-Current, Rail-to-Rail I/O, e-trim™ Operational Amplifiers data sheet](#)

9.3 Receiving Notification of Documentation Updates

To receive notification of documentation updates, navigate to the device product folder on [ti.com](#). Click on *Notifications* to register and receive a weekly digest of any product information that has changed. For change details, review the revision history included in any revised document.

9.4 Support Resources

[TI E2E™ support forums](#) are an engineer's go-to source for fast, verified answers and design help — straight from the experts. Search existing answers or ask your own question to get the quick design help you need.

Linked content is provided "AS IS" by the respective contributors. They do not constitute TI specifications and do not necessarily reflect TI's views; see TI's [Terms of Use](#).

9.5 Trademarks

TINA-TI™ and TI E2E™ are trademarks of Texas Instruments.

TINA™ is a trademark of DesignSoft, Inc.

PSPICE® is a registered trademark of Cadence Design Systems, Inc.

All trademarks are the property of their respective owners.

9.6 Electrostatic Discharge Caution



This integrated circuit can be damaged by ESD. Texas Instruments recommends that all integrated circuits be handled with appropriate precautions. Failure to observe proper handling and installation procedures can cause damage.

ESD damage can range from subtle performance degradation to complete device failure. Precision integrated circuits may be more susceptible to damage because very small parametric changes could cause the device not to meet its published specifications.

9.7 Glossary

[TI Glossary](#) This glossary lists and explains terms, acronyms, and definitions.

10 Revision History

NOTE: Page numbers for previous revisions may differ from page numbers in the current version.

Changes from Revision * (October 2023) to Revision A (December 2023)	Page
• Updated definition of t_M throughout document and updated specification values accordingly.....	1
• Updated typical parameter values throughout document, based on larger sample size of data.....	1
• Updated absolute maximum and recommended maximum voltage and current ratings throughout document to extend usable range of device.....	1
• Added histograms and characteristic curves to <i>Typical Characteristics</i>	9
• Added <i>Parameter Measurement Information</i> section.....	13
• Added <i>Predictable Voltage Coefficient</i> section.....	17
• Added input impedance mismatch text to <i>Difference-Amplifier Common-Mode Rejection Analysis</i>	19
• Changed V_{RAIL} to V_{BUS} in <i>Common-Mode Shifting Input Stage</i>	23
• Changed guidance in <i>Power Supply Recommendations</i> to reflect updated absolute and recommended maximum specs.....	26

11 Mechanical, Packaging, and Orderable Information

The following pages include mechanical, packaging, and orderable information. This information is the most current data available for the designated devices. This data is subject to change without notice and revision of this document. For browser-based versions of this data sheet, refer to the left-hand navigation.

11.1 Tape and Reel Information

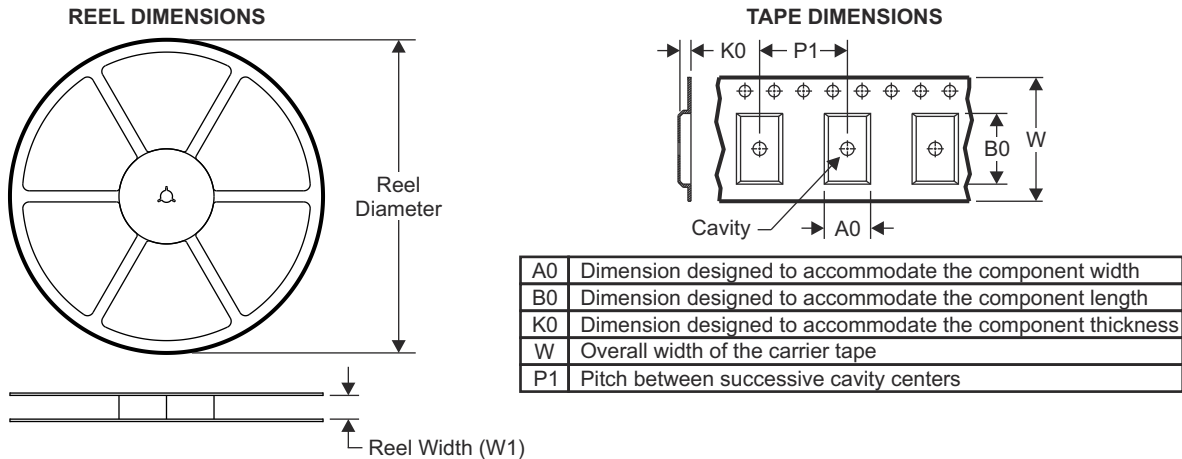

QUADRANT ASSIGNMENTS FOR PIN 1 ORIENTATION IN TAPE

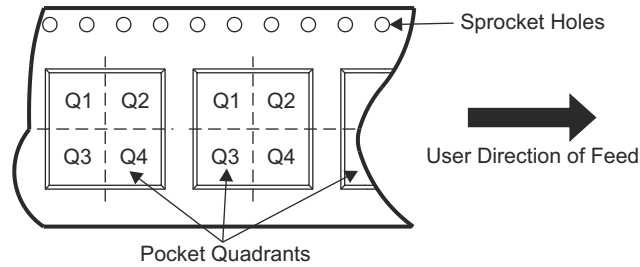

Device	Package Type	Package Drawing	Pins	SPQ	Reel Diameter (mm)	Reel Width W1 (mm)	A0 (mm)	B0 (mm)	K0 (mm)	P1 (mm)	W (mm)	Pin1 Quadrant
PRES11A00QDDFRQ1	SOT-23-THIN	DDF	8	3000	180.0	8.4	3.2	3.2	1.4	4.0	8.0	Q3
PRES11A10QDDFRQ1	SOT-23-THIN	DDF	8	3000	180.0	8.4	3.2	3.2	1.4	4.0	8.0	Q3
PRES11A150QDDFRQ1	SOT-23-THIN	DDF	8	3000	180.0	8.4	3.2	3.2	1.4	4.0	8.0	Q3
PRES11A16QDDFRQ1	SOT-23-THIN	DDF	8	3000	180.0	8.4	3.2	3.2	1.4	4.0	8.0	Q3
PRES11A20QDDFRQ1	SOT-23-THIN	DDF	8	3000	180.0	8.4	3.2	3.2	1.4	4.0	8.0	Q3
PRES11A25QDDFRQ1	SOT-23-THIN	DDF	8	3000	180.0	8.4	3.2	3.2	1.4	4.0	8.0	Q3
PRES11A30QDDFRQ1	SOT-23-THIN	DDF	8	3000	180.0	8.4	3.2	3.2	1.4	4.0	8.0	Q3
PRES11A40QDDFRQ1	SOT-23-THIN	DDF	8	3000	180.0	8.4	3.2	3.2	1.4	4.0	8.0	Q3
PRES11A50QDDFRQ1	SOT-23-THIN	DDF	8	3000	180.0	8.4	3.2	3.2	1.4	4.0	8.0	Q3
PRES11A90QDDFRQ1	SOT-23-THIN	DDF	8	3000	180.0	8.4	3.2	3.2	1.4	4.0	8.0	Q3

TAPE AND REEL BOX DIMENSIONS

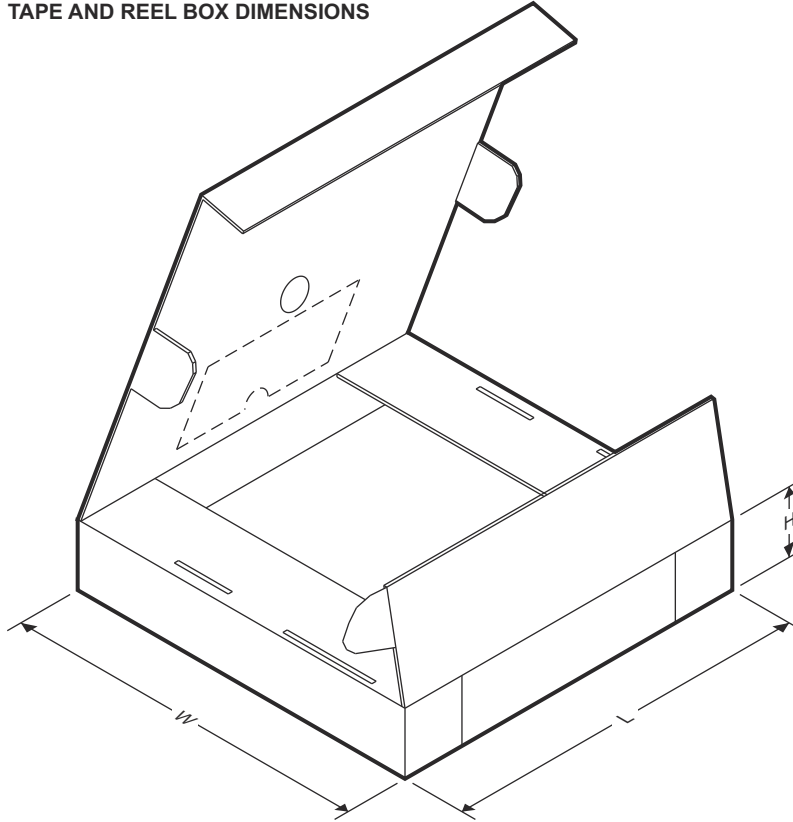

Device	Package Type	Package Drawing	Pins	SPQ	Length (mm)	Width (mm)	Height (mm)
PRES11A00QDDFRQ1	SOT-23-THIN	DFF	8	3000	201.0	185.0	35.0
PRES11A10QDDFRQ1	SOT-23-THIN	DFF	8	3000	201.0	185.0	35.0
PRES11A15QDDFRQ1	SOT-23-THIN	DFF	8	3000	201.0	185.0	35.0
PRES11A16QDDFRQ1	SOT-23-THIN	DFF	8	3000	201.0	185.0	35.0
PRES11A20QDDFRQ1	SOT-23-THIN	DFF	8	3000	201.0	185.0	35.0
PRES11A25QDDFRQ1	SOT-23-THIN	DFF	8	3000	201.0	185.0	35.0
PRES11A30QDDFRQ1	SOT-23-THIN	DFF	8	3000	201.0	185.0	35.0
PRES11A40QDDFRQ1	SOT-23-THIN	DFF	8	3000	201.0	185.0	35.0
PRES11A50QDDFRQ1	SOT-23-THIN	DFF	8	3000	201.0	185.0	35.0
PRES11A90QDDFRQ1	SOT-23-THIN	DFF	8	3000	201.0	185.0	35.0

11.2 Mechanical Data



DDF0008A

PACKAGE OUTLINE
SOT-23 - 1.1 mm max height

PLASTIC SMALL OUTLINE

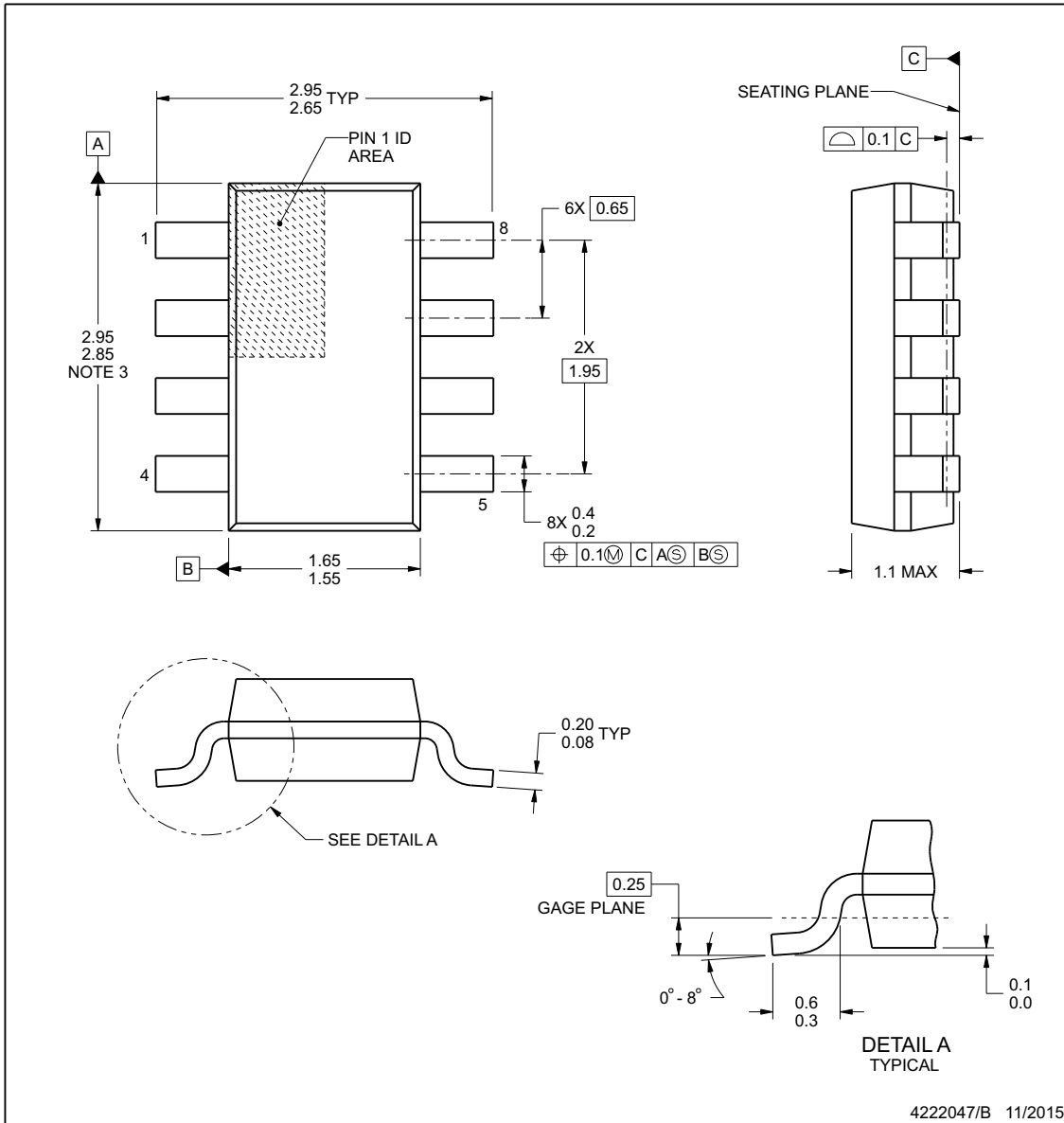

NOTES:

1. All linear dimensions are in millimeters. Any dimensions in parenthesis are for reference only. Dimensioning and tolerancing per ASME Y14.5M.
2. This drawing is subject to change without notice.
3. This dimension does not include mold flash, protrusions, or gate burrs. Mold flash, protrusions, or gate burrs shall not exceed 0.15 mm per side.

EXAMPLE BOARD LAYOUT

DDF0008A

SOT-23 - 1.1 mm max height

PLASTIC SMALL OUTLINE

ADVANCE INFORMATION

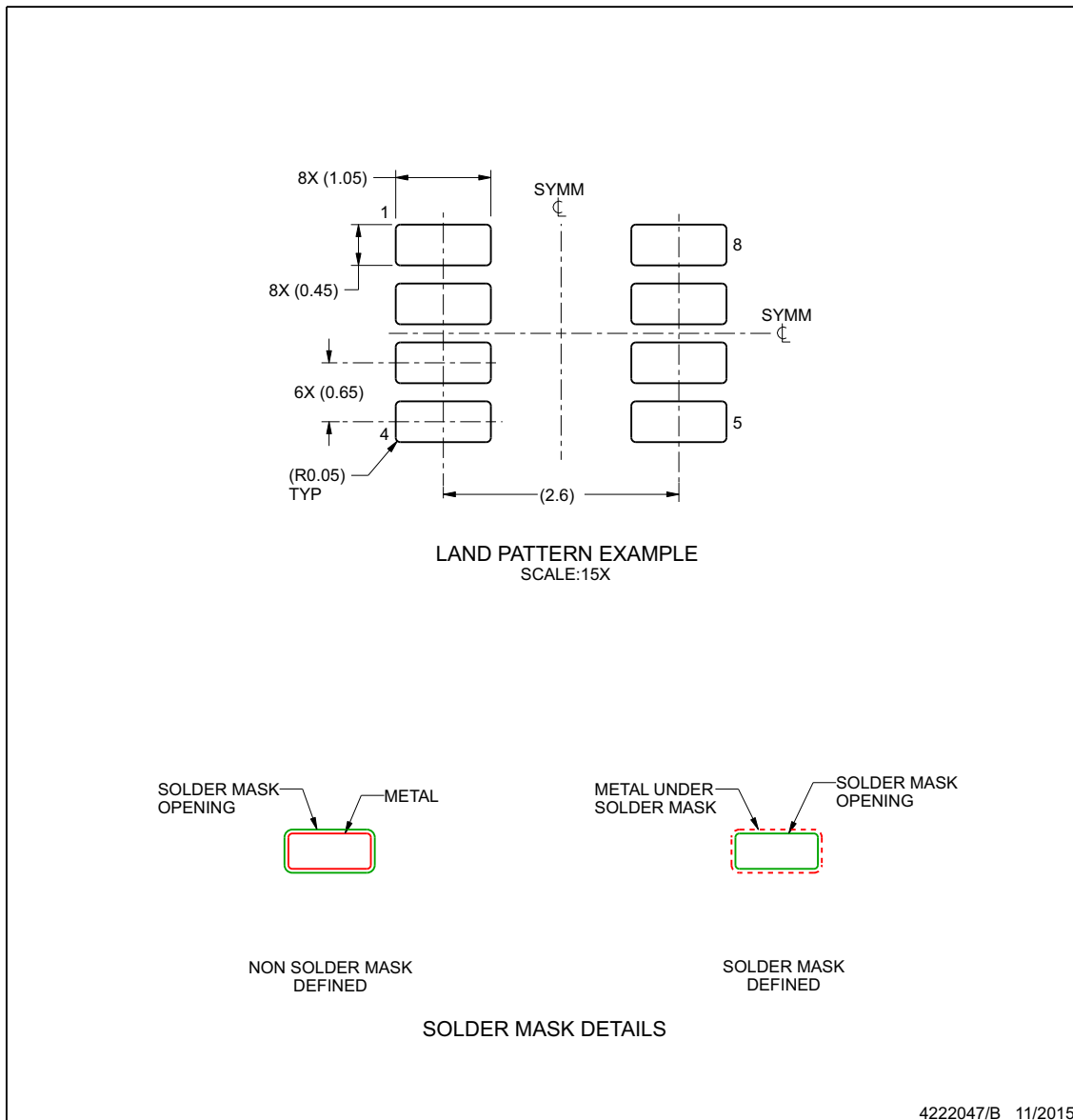

NOTES: (continued)

- 4. Publication IPC-7351 may have alternate designs.
- 5. Solder mask tolerances between and around signal pads can vary based on board fabrication site.

EXAMPLE STENCIL DESIGN

DDF0008A

SOT-23 - 1.1 mm max height

PLASTIC SMALL OUTLINE

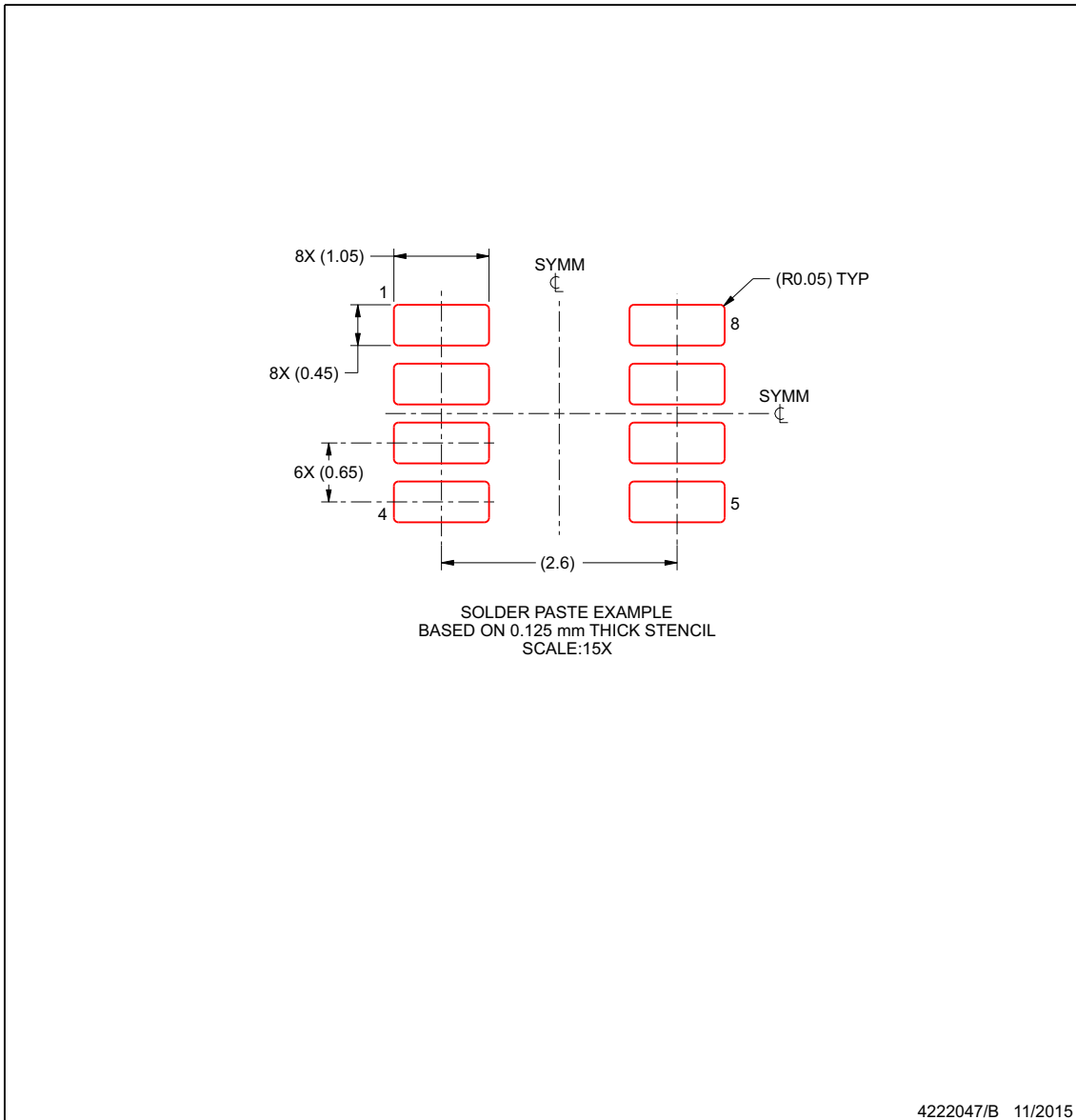

NOTES: (continued)

6. Laser cutting apertures with trapezoidal walls and rounded corners may offer better paste release. IPC-7525 may have alternate design recommendations.
7. Board assembly site may have different recommendations for stencil design.

ADVANCE INFORMATION

PACKAGING INFORMATION

Orderable part number	Status (1)	Material type (2)	Package Pins	Package qty Carrier	RoHS (3)	Lead finish/ Ball material (4)	MSL rating/ Peak reflow (5)	Op temp (°C)	Part marking (6)
PRES11A00QDDFRQ1	Active	Preproduction	SOT-23-THIN (DDF) 8	3000 LARGE T&R	-	Call TI	Call TI	-40 to 125	
PRES11A00QDDFRQ1.A	Active	Preproduction	SOT-23-THIN (DDF) 8	3000 LARGE T&R	-	Call TI	Call TI	-40 to 125	
PRES11A10QDDFRQ1	Active	Preproduction	SOT-23-THIN (DDF) 8	3000 LARGE T&R	-	Call TI	Call TI	-40 to 125	
PRES11A10QDDFRQ1.A	Active	Preproduction	SOT-23-THIN (DDF) 8	3000 LARGE T&R	-	Call TI	Call TI	-40 to 125	
PRES11A15QDDFRQ1	Active	Preproduction	SOT-23-THIN (DDF) 8	3000 LARGE T&R	-	Call TI	Call TI	-40 to 125	
PRES11A15QDDFRQ1.A	Active	Preproduction	SOT-23-THIN (DDF) 8	3000 LARGE T&R	-	Call TI	Call TI	-40 to 125	
PRES11A16QDDFRQ1	Active	Preproduction	SOT-23-THIN (DDF) 8	3000 LARGE T&R	-	Call TI	Call TI	-40 to 125	
PRES11A16QDDFRQ1.A	Active	Preproduction	SOT-23-THIN (DDF) 8	3000 LARGE T&R	-	Call TI	Call TI	-40 to 125	
PRES11A20QDDFRQ1	Active	Preproduction	SOT-23-THIN (DDF) 8	3000 LARGE T&R	-	Call TI	Call TI	-40 to 125	
PRES11A20QDDFRQ1.A	Active	Preproduction	SOT-23-THIN (DDF) 8	3000 LARGE T&R	-	Call TI	Call TI	-40 to 125	
PRES11A30QDDFRQ1	Active	Preproduction	SOT-23-THIN (DDF) 8	3000 LARGE T&R	-	Call TI	Call TI	-40 to 125	
PRES11A30QDDFRQ1.A	Active	Preproduction	SOT-23-THIN (DDF) 8	3000 LARGE T&R	-	Call TI	Call TI	-40 to 125	
PRES11A40QDDFRQ1	Active	Preproduction	SOT-23-THIN (DDF) 8	3000 LARGE T&R	-	Call TI	Call TI	-40 to 125	
PRES11A40QDDFRQ1.A	Active	Preproduction	SOT-23-THIN (DDF) 8	3000 LARGE T&R	-	Call TI	Call TI	-40 to 125	
PRES11A50QDDFRQ1	Active	Preproduction	SOT-23-THIN (DDF) 8	3000 LARGE T&R	-	Call TI	Call TI	-40 to 125	
PRES11A50QDDFRQ1.A	Active	Preproduction	SOT-23-THIN (DDF) 8	3000 LARGE T&R	-	Call TI	Call TI	-40 to 125	
PRES11A90QDDFRQ1	Active	Preproduction	SOT-23-THIN (DDF) 8	3000 LARGE T&R	-	Call TI	Call TI	-40 to 125	
PRES11A90QDDFRQ1.A	Active	Preproduction	SOT-23-THIN (DDF) 8	3000 LARGE T&R	-	Call TI	Call TI	-40 to 125	

(1) **Status:** For more details on status, see our [product life cycle](#).

(2) **Material type:** When designated, preproduction parts are prototypes/experimental devices, and are not yet approved or released for full production. Testing and final process, including without limitation quality assurance, reliability performance testing, and/or process qualification, may not yet be complete, and this item is subject to further changes or possible discontinuation. If available for ordering, purchases will be subject to an additional waiver at checkout, and are intended for early internal evaluation purposes only. These items are sold without warranties of any kind.

(3) **RoHS values:** Yes, No, RoHS Exempt. See the [TI RoHS Statement](#) for additional information and value definition.

(4) **Lead finish/Ball material:** Parts may have multiple material finish options. Finish options are separated by a vertical ruled line. Lead finish/Ball material values may wrap to two lines if the finish value exceeds the maximum column width.

(5) **MSL rating/Peak reflow:** The moisture sensitivity level ratings and peak solder (reflow) temperatures. In the event that a part has multiple moisture sensitivity ratings, only the lowest level per JEDEC standards is shown. Refer to the shipping label for the actual reflow temperature that will be used to mount the part to the printed circuit board.

(6) **Part marking:** There may be an additional marking, which relates to the logo, the lot trace code information, or the environmental category of the part.

Multiple part markings will be inside parentheses. Only one part marking contained in parentheses and separated by a "~" will appear on a part. If a line is indented then it is a continuation of the previous line and the two combined represent the entire part marking for that device.

Important Information and Disclaimer:The information provided on this page represents TI's knowledge and belief as of the date that it is provided. TI bases its knowledge and belief on information provided by third parties, and makes no representation or warranty as to the accuracy of such information. Efforts are underway to better integrate information from third parties. TI has taken and continues to take reasonable steps to provide representative and accurate information but may not have conducted destructive testing or chemical analysis on incoming materials and chemicals. TI and TI suppliers consider certain information to be proprietary, and thus CAS numbers and other limited information may not be available for release.

In no event shall TI's liability arising out of such information exceed the total purchase price of the TI part(s) at issue in this document sold by TI to Customer on an annual basis.

OTHER QUALIFIED VERSIONS OF RES11A-Q1 :

- Catalog : [RES11A](#)

NOTE: Qualified Version Definitions:

- Catalog - TI's standard catalog product

DDF0008A



PACKAGE OUTLINE

SOT-23-THIN - 1.1 mm max height

PLASTIC SMALL OUTLINE



NOTES:

1. All linear dimensions are in millimeters. Any dimensions in parenthesis are for reference only. Dimensioning and tolerancing per ASME Y14.5M.
2. This drawing is subject to change without notice.
3. This dimension does not include mold flash, protrusions, or gate burrs. Mold flash, protrusions, or gate burrs shall not exceed 0.15 mm per side.

EXAMPLE BOARD LAYOUT

DDF0008A

SOT-23-THIN - 1.1 mm max height

PLASTIC SMALL OUTLINE



LAND PATTERN EXAMPLE
EXPOSED METAL SHOWN
SCALE:15X

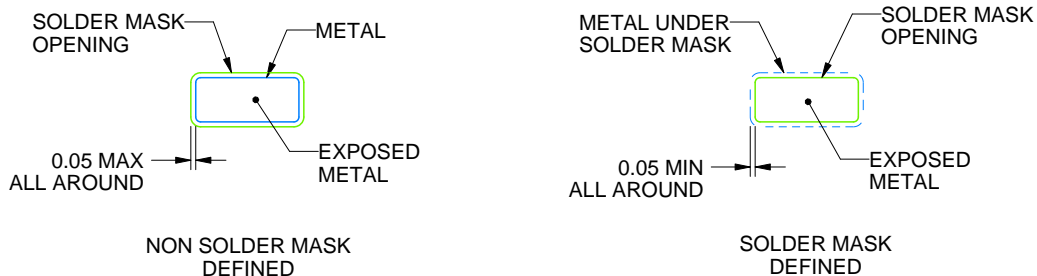

SOLDER MASK DETAILS

4222047/E 07/2024

NOTES: (continued)

- 4. Publication IPC-7351 may have alternate designs.
- 5. Solder mask tolerances between and around signal pads can vary based on board fabrication site.

EXAMPLE STENCIL DESIGN

DDF0008A

SOT-23-THIN - 1.1 mm max height

PLASTIC SMALL OUTLINE



SOLDER PASTE EXAMPLE
BASED ON 0.125 mm THICK STENCIL
SCALE:15X

4222047/E 07/2024

NOTES: (continued)

6. Laser cutting apertures with trapezoidal walls and rounded corners may offer better paste release. IPC-7525 may have alternate design recommendations.
7. Board assembly site may have different recommendations for stencil design.

IMPORTANT NOTICE AND DISCLAIMER

TI PROVIDES TECHNICAL AND RELIABILITY DATA (INCLUDING DATA SHEETS), DESIGN RESOURCES (INCLUDING REFERENCE DESIGNS), APPLICATION OR OTHER DESIGN ADVICE, WEB TOOLS, SAFETY INFORMATION, AND OTHER RESOURCES "AS IS" AND WITH ALL FAULTS, AND DISCLAIMS ALL WARRANTIES, EXPRESS AND IMPLIED, INCLUDING WITHOUT LIMITATION ANY IMPLIED WARRANTIES OF MERCHANTABILITY, FITNESS FOR A PARTICULAR PURPOSE OR NON-INFRINGEMENT OF THIRD PARTY INTELLECTUAL PROPERTY RIGHTS.

These resources are intended for skilled developers designing with TI products. You are solely responsible for (1) selecting the appropriate TI products for your application, (2) designing, validating and testing your application, and (3) ensuring your application meets applicable standards, and any other safety, security, regulatory or other requirements.

These resources are subject to change without notice. TI grants you permission to use these resources only for development of an application that uses the TI products described in the resource. Other reproduction and display of these resources is prohibited. No license is granted to any other TI intellectual property right or to any third party intellectual property right. TI disclaims responsibility for, and you will fully indemnify TI and its representatives against, any claims, damages, costs, losses, and liabilities arising out of your use of these resources.

TI's products are provided subject to [TI's Terms of Sale](#) or other applicable terms available either on [ti.com](https://www.ti.com) or provided in conjunction with such TI products. TI's provision of these resources does not expand or otherwise alter TI's applicable warranties or warranty disclaimers for TI products.

TI objects to and rejects any additional or different terms you may have proposed.

Mailing Address: Texas Instruments, Post Office Box 655303, Dallas, Texas 75265
Copyright © 2025, Texas Instruments Incorporated