

LM34966-Q1 500kHz Wide VIN Non-synchronous Boost/SEPIC/Flyback Controller

1 Features

- AEC-Q100 qualified for automotive applications
 - Temperature grade 1: -40°C to $+125^{\circ}\text{C}$ T_A
 - Maximum operating temperature 150°C T_J
- **Functional Safety-Capable**
 - [Documentation available to aid functional safety system design](#)
- Suited for wide input operating range car battery applications
 - 3.5-V to 40-V operating range (45-V abs max)
 - 2.97-V to 16-V when $\text{BIAS} = \text{VCC}$
 - Minimum boost supply voltage 1.5 V when $\text{BIAS} \geq 3.5 \text{ V}$
 - Input transient protection up to 45 V
 - Minimized battery drain
 - Low shutdown current ($I_Q \leq 2.6 \mu\text{A}$)
 - Low operating current ($I_Q \leq 490 \mu\text{A}$)
- Small solution size and low cost
 - Integrated error amplifier allows primary-side regulation without optocoupler (flyback)
 - Minimized undershoot during cranking (start-stop application)
- Higher efficiency with low-power dissipation
 - 100-mV $\pm 7\%$ accurate current limit threshold
 - Strong 1.0-A peak standard MOSFET driver
 - Supports external VCC supply
- Avoid AM band interference and crosstalk
 - Optional clock synchronization
 - Dynamically programmable switching frequency from 100 kHz to 500 kHz
- Integrated protection features
 - Constant peak current limiting over input voltage
 - Hiccup mode overload protection
 - Programmable line UVLO
 - OVP protection
 - Thermal shutdown
- Accurate $\pm 1\%$ accuracy feedback reference
- Programmable extra slope compensation
- Adjustable soft start
- PGOOD indicator
- 14-Pin HTSSOP package (5.0 mm \times 4.4 mm)
- Create a custom design using the LM34966-Q1 with the [WEBENCH® power designer](#)

2 Applications

- [Automotive 12-V battery application](#)
- [Automotive start-stop application](#)
- [High voltage LiDAR power supply](#)
- [Multiple-output flyback without optocoupler](#)
- [Automotive rear-lights LED bias supply](#)
- [Wide input boost, SEPIC, flyback power module](#)
- [Audio amplifier application](#)
- [Battery-powered boost, SEPIC, flyback](#)

3 Description

The LM34966-Q1 is a wide input range, non-synchronous boost controller that uses peak current mode control. The device can be used in boost, SEPIC, and flyback topologies. The device can start up from a 1-cell battery with a minimum of 2.97 V if the BIAS pin is connected to the VCC pin. It can operate with the input supply voltage as low as 1.5 V if the BIAS pin is greater than 3.5 V. The internal VCC regulator also supports BIAS pin operation up to 40 V (45-V absolute maximum) for automotive load dump. The switching frequency is dynamically programmable with an external resistor from 100 kHz to 500 kHz.

Device Information

PART NUMBER	PACKAGE ⁽¹⁾	BODY SIZE (NOM)
LM34966-Q1	HTSSOP (14)	5.0 mm \times 4.4 mm

(1) For all available packages, see the orderable addendum at the end of the data sheet.

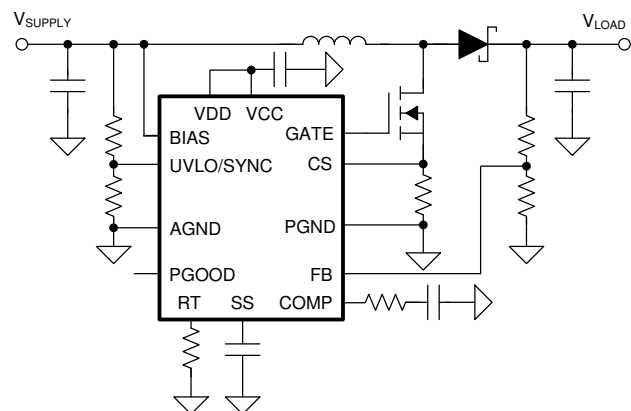

Typical Boost Application



Table of Contents

1 Features	1	9 Application and Implementation	25
2 Applications	1	9.1 Power-On Hours (POH).....	25
3 Description	1	9.2 Application Information.....	25
4 Revision History	2	9.3 Typical Application.....	25
5 Description (continued)	2	9.4 System Examples.....	30
6 Pin Configuration and Functions	3	10 Power Supply Recommendations	35
Pin Functions.....	3	11 Layout	36
7 Specifications	5	11.1 Layout Guidelines.....	36
7.1 Absolute Maximum Ratings.....	5	11.2 Layout Examples.....	37
7.2 ESD Ratings.....	5	12 Device and Documentation Support	39
7.3 Recommended Operating Conditions.....	6	12.1 Device Support.....	39
7.4 Thermal Information.....	6	12.2 Receiving Notification of Documentation Updates..	39
7.5 Electrical Characteristics.....	6	12.3 Support Resources.....	39
7.6 Typical Characteristics.....	8	12.4 Trademarks.....	39
8 Detailed Description	11	12.5 Electrostatic Discharge Caution.....	40
8.1 Overview.....	11	12.6 Glossary.....	40
8.2 Functional Block Diagram.....	11	13 Mechanical, Packaging, and Orderable Information	41
8.3 Feature Description.....	12		
8.4 Device Functional Modes.....	24		

4 Revision History

DATE	REVISION	NOTES
September 2020	*	Initial release.

5 Description (continued)

The device features a 1.0-A standard MOSFET driver and a low 100-mV current limit threshold. The device also supports the use of an external VCC supply to improve efficiency. Low operating current and pulse-skipping operation improve efficiency at light loads. The device has built-in protection features such as cycle-by-cycle current limit, overvoltage protection, line UVLO, thermal shutdown, and hiccup mode overload protection. Additional features include low shutdown I_Q , programmable soft start, programmable slope compensation, precision reference, power-good indicator, and external clock synchronization.

6 Pin Configuration and Functions

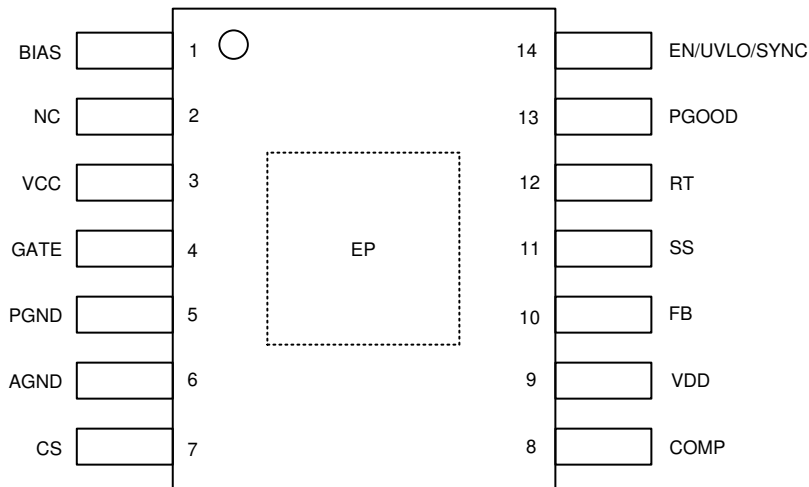

Figure 6-1. 14-Pin HTSSOP PWP Package (Transparent Top View)

Pin Functions

PIN		TYPE ⁽¹⁾	DESCRIPTION
NO.	NAME		
1	BIAS	P	Supply voltage input to the VCC regulator. Connect a bypass capacitor from this pin to PGND.
2	NC	-	No electrical contact
3	VCC	P	Output of the internal VCC regulator and supply voltage input of the MOSFET driver. Connect a ceramic bypass capacitor from this pin to PGND.
4	GATE	O	N-channel MOSFET gate drive output. Connect directly to the gate of the N-channel MOSFET through a short, low inductance path.
5	PGND	G	Power ground pin. Connect directly to the ground connection of the sense resistor through a low inductance wide and short path.
6	AGND	G	Analog ground pin. Connect directly to the analog ground plane through a wide and short path.
7	CS	I	Current sense input pin. Connect to the positive side of the current sense resistor through a short path.
8	COMP	O	Output of the internal transconductance error amplifier. Connect the loop compensation components between this pin and ground plane.
9	VDD	I	Input of the internal logic. Connect directly to VCC.
10	FB	I	Inverting input of the error amplifier. Connect a voltage divider from the output to this pin to set output voltage in boost/SEPIC/non-isolated flyback topologies. Connect the low-side feedback resistor to AGND.
11	SS	I	Soft-start time programming pin. An external capacitor and an internal current source set the ramp rate of the internal error amplifier reference during soft start. Connect the ground connection of the capacitor to AGND.
12	RT	I	Switching frequency setting pin. The switching frequency is programmed by a single resistor between RT and AGND.
13	PGOOD	O	Power-good indicator. An open-drain output which goes low if FB is below the undervoltage threshold. Connect a pullup resistor to the system voltage rail. If not used, leave the pin floating.
14	EN/UVLO/ SYNC	I	Undervoltage lockout programming pin. The converter start-up and shutdown levels can be programmed by connecting this pin to the supply voltage through a resistor divider. The internal clock can be synchronized to an external clock by applying a negative pulse signal into the EN/UVLO/SYNC pin. This pin must not be left floating. Connect to BIAS pin if not used. Connect the low-side UVLO resistor to AGND.

PIN		TYPE ⁽¹⁾	DESCRIPTION
NO.	NAME		
—	EP	—	Exposed pad of the package. The exposed pad must be connected to AGND and the large ground copper plane to decrease thermal resistance.

(1) G = Ground, I = Input, O = Output, P = Power

7 Specifications

7.1 Absolute Maximum Ratings

Over the recommended operating junction temperature range⁽¹⁾

		MIN	MAX	UNIT
Input	BIAS to AGND	-0.3	45	V
	UVLO to AGND	-0.3	$V_{BIAS}+0.3$	
	SS to AGND ⁽²⁾	-0.3	3.8	
	RT to AGND ⁽²⁾	-0.3	3.8	
	FB to AGND	-0.3	4.0	
	CS to AGND(DC)	-0.3	0.3	
	CS to AGND (50ns transient)	-1		
	PGND to AGND	-0.3	0.3	
	VDD to AGND	-0.3	18	
	Output	VCC to AGND	-0.3	
GATE to AGND (50ns transient)		-1		
PGOOD to AGND ⁽⁴⁾		-0.3	18	
COMP to AGND ⁽⁵⁾		-0.3		
Junction temperature, T_J ⁽⁶⁾		-40	150	°C
Storage temperature, T_{stg}		-55	150	

- (1) Stresses beyond those listed under *Absolute Maximum Ratings* may cause permanent damage to the device. These are stress ratings only, which do not imply functional operation of the device at these or any other conditions beyond those indicated under *Recommended Operating Conditions*. Exposure to absolute-maximum-rated conditions for extended periods may affect device reliability.
- (2) This pin is not specified to have an external voltage applied.
- (3) 18 V or $V_{BIAS} + 0.3$ V whichever is lower
- (4) The maximum current sink is limited to 1 mA when $V_{PGOOD} > V_{BIAS}$.
- (5) This pin has an internal max voltage clamp which can handle up to 1.6 mA.
- (6) High junction temperatures degrade operating lifetimes. Operating lifetime is de-rated for junction temperatures greater than 125°C.

7.2 ESD Ratings

			VALUE	UNIT	
$V_{(ESD)}$	Electrostatic discharge	Human-body model (HBM), per AEC Q100-002 ⁽¹⁾ HBM ESD Classification Level 2	±2000	V	
		Charged-device model (CDM), per AEC Q100-011 CDM ESD Classification Level C4B	All pins		±500
			Corner pins		±750

- (1) AEC Q100-002 indicates that HBM stressing shall be in accordance with the ANSI/ESDA/JEDEC JS-001 specification.

7.3 Recommended Operating Conditions

Over the recommended operating junction temperature range⁽¹⁾

		MIN	NOM	MAX	UNIT
V _{BIAS}	Bias input ⁽²⁾	2.97		40	V
V _{VCC}	VCC voltage ⁽³⁾	2.97		16	V
V _{VDD}	VDD input	2.1		16	V
V _{UVLO}	UVLO input	0		40	V
V _{FB}	FB input	0		4.0	V
f _{SW}	Typical switching frequency	100		500	kHz
f _{SYNC}	Synchronization pulse frequency	100		500	kHz
T _J	Operating junction temperature ⁽⁴⁾	-40		150	°C

- (1) **Operating Ratings** are conditions under the device is intended to be functional. For specifications and test conditions, see [Electrical Characteristics](#).
- (2) BIAS pin operating range is from 2.97V to 16V when VCC is directly connected to BIAS. BIAS pin operating range is from 3.5V to 40V when VCC is supplied from the internal VCC regulator.
- (3) This pin voltage should be less than V_{BIAS} + 0.3 V.
- (4) High junction temperatures degrade operating lifetimes. Operating lifetime is de-rated for junction temperatures greater than 125°C.

7.4 Thermal Information

THERMAL METRIC ⁽¹⁾		LM34966-Q1	UNIT
		PWP(HTSSOP)	
		14 PINS	
R _{θJA}	Junction-to-ambient thermal resistance (LM34966EVM-FLY)	54.7	°C/W
R _{θJA}	Junction-to-ambient thermal resistance	44.1	°C/W
R _{θJC(top)}	Junction-to-case (top) thermal resistance	49.1	°C/W
R _{θJB}	Junction-to-board thermal resistance	20.7	°C/W
ψ _{JT}	Junction-to-top characterization parameter (LM34966EVM-FLY)	2.0	°C/W
ψ _{JT}	Junction-to-top characterization parameter	2.3	°C/W
ψ _{JB}	Junction-to-board characterization parameter (LM34966EVM-FLY)	17.3	°C/W
ψ _{JB}	Junction-to-board characterization parameter	20.7	°C/W
R _{θJC(bot)}	Junction-to-case (bottom) thermal resistance	7.9	°C/W

- (1) For more information about traditional and new thermal metrics, see the [Semiconductor and IC Package Thermal Metrics application report](#).

7.5 Electrical Characteristics

Typical values correspond to T_J = 25°C. Minimum and maximum limits apply over T_J = -40°C to 150°C. Unless otherwise stated, V_{BIAS} = 12 V, R_T = 220 kΩ

PARAMETER		TEST CONDITIONS	MIN	TYP	MAX	UNIT
SUPPLY CURRENT						
I _{SHUTDOWN(BIAS)}	BIAS shutdown current	V _{BIAS} = 12 V, V _{UVLO} = 0 V		2.6	6	μA
I _{OPERATING(BIAS)}	BIAS operating current	V _{BIAS} = 12 V, V _{UVLO} = 2.0 V, V _{FB} = V _{REF} , R _T = 220 kΩ		490	1200	μA
VCC REGULATOR						
V _{VCC-REG}	VCC regulation	V _{BIAS} = 8 V, No load	6.5	6.85	7	V
	VCC regulation	V _{BIAS} = 8 V, I _{VCC} = 35 mA	6.5			V
V _{VCC-UVLO(RISING)}	VCC UVLO threshold	VCC rising	2.75	2.85	2.95	V
	VCC UVLO hysteresis	VCC falling		0.063		V
I _{VCC-CL}	VCC sourcing current limit	V _{BIAS} = 10 V, V _{VCC} = 0 V	20	110		mA
ENABLE						

Typical values correspond to $T_J = 25^\circ\text{C}$. Minimum and maximum limits apply over $T_J = -40^\circ\text{C}$ to 150°C . Unless otherwise stated, $V_{\text{BIAS}} = 12\text{ V}$, $R_T = 220\text{ k}\Omega$

PARAMETER		TEST CONDITIONS	MIN	TYP	MAX	UNIT
$V_{\text{EN(RISING)}}$	Enable threshold	EN rising	0.4	0.52	0.7	V
$V_{\text{EN(FALLING)}}$	Enable threshold	EN falling	0.33	0.49	0.63	V
$V_{\text{EN(HYS)}}$	Enable hysteresis	EN falling		0.03		V
UVLO/SYNC						
$V_{\text{UVLO(RISING)}}$	UVLO / SYNC threshold	UVLO rising	1.425	1.5	1.575	V
$V_{\text{UVLO(FALLING)}}$	UVLO / SYNC threshold	UVLO falling	1.370	1.45	1.520	V
$V_{\text{UVLO(HYS)}}$	UVLO / SYNC threshold hysteresis	UVLO falling		0.05		V
I_{UVLO}	UVLO hysteresis current	$V_{\text{UVLO}} = 1.6\text{ V}$	4	5	6	μA
SS						
I_{SS}	Soft-start current		9	10	11	μA
	SS pull-down switch $r_{\text{DS(on)}}$			55		Ω
PULSE WIDTH MODULATION						
fsw	Switching frequency	$R_T = 220\text{ k}\Omega$, $V_{\text{BIAS}} = 4\text{ V}$	85	100	115	kHz
D_{MAX}	Maximum duty cycle limit	$R_T = 220\text{ k}\Omega$, $V_{\text{BIAS}} = 4\text{ V}$	90	93	96	%
CURRENT SENSE						
I_{SLOPE}	Peak slope compensation current	$R_T = 220\text{ k}\Omega$	22.5	30	37.5	μA
V_{CLTH}	Current Limit threshold (CS-PGND)		93	100	107	mV
HICCUP MODE PROTECTION						
	Hiccup enable cycles			64		Cycles
	Hiccup timer reset cycles			8		Cycles
ERROR AMPLIFIER						
V_{REF}	FB reference		0.99	1	1.01	V
Gm	Transconductance			2		mA/V
	COMP sourcing current	$V_{\text{COMP}} = 1.2\text{ V}$	180			μA
	COMP clamp voltage	COMP rising ($V_{\text{UVLO}} = 2.0\text{ V}$)	2.5	2.8		V
	COMP clamp voltage	COMP falling		1	1.15	V
OVP						
V_{OVTH}	Over-voltage threshold	FB rising (in reference to V_{REF})	107	110	113	%
	Over-voltage threshold	FB falling (in reference to V_{REF})		105		%
PGOOD						
	PGOOD pull-down switch $r_{\text{DS(on)}}$	1 mA sinking		90		Ω
V_{UVTH}	Under-voltage threshold	FB falling (in reference to V_{REF})	87	90	93	%
	Under-voltage threshold	FB rising (in reference to V_{REF})		95		%
MOSFET DRIVER						
	High-state voltage drop	100 mA sinking		0.25		V
	Low-state voltage drop	100 mA sourcing		0.15		V
THERMAL SHUTDOWN						
T_{TSD}	Thermal shutdown threshold	Temperature rising		175		$^\circ\text{C}$
	Thermal shutdown hysteresis			15		$^\circ\text{C}$

7.6 Typical Characteristics

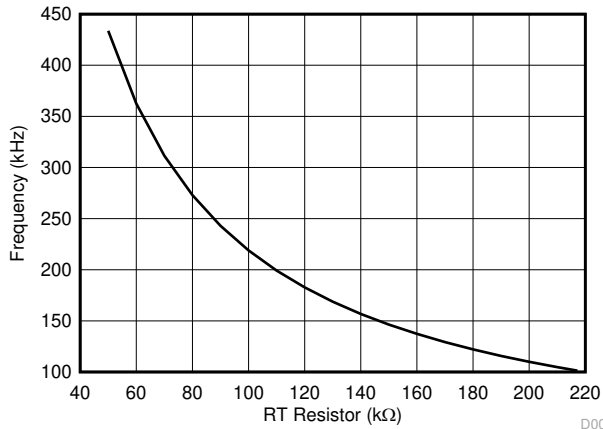

Figure 7-1. Frequency vs RT Resistance

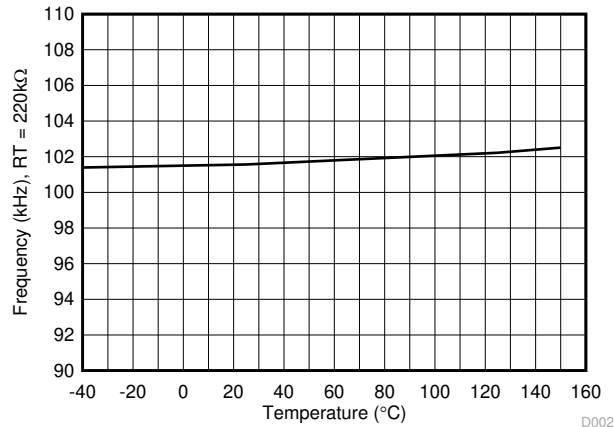

Figure 7-2. Frequency vs Temperature

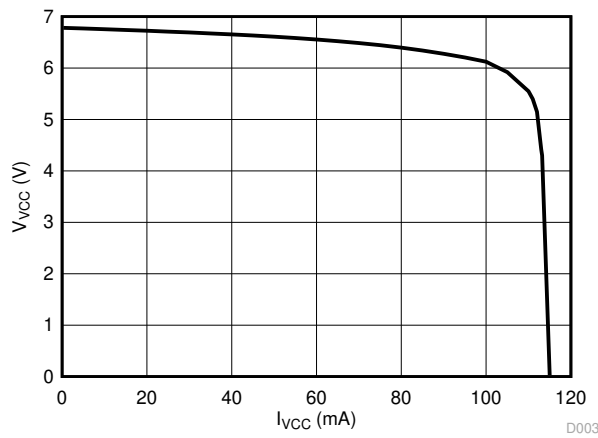

Figure 7-3. V_VCC vs I_VCC

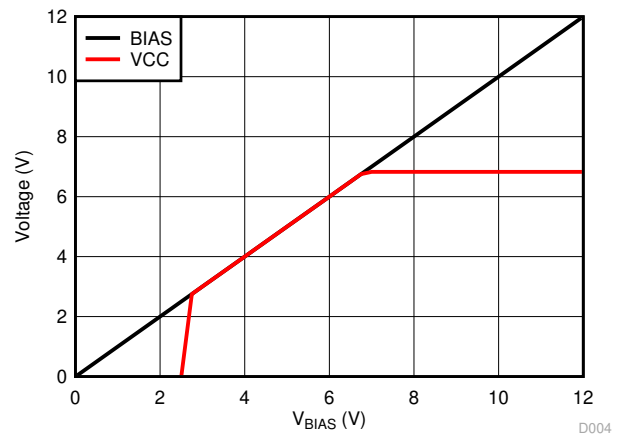

Figure 7-4. V_VCC vs V_BIAS (No Load)

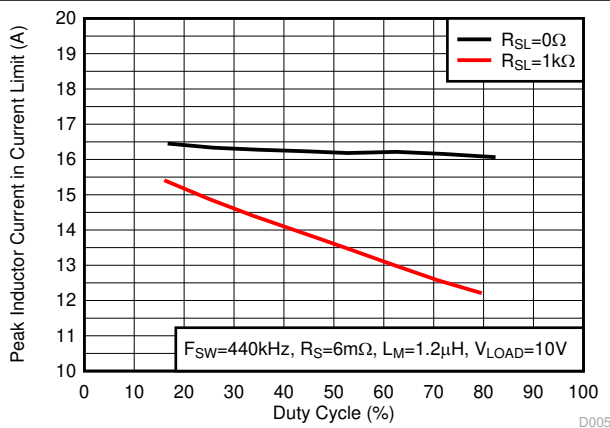

Figure 7-5. Peak Current Limit vs Duty Cycle

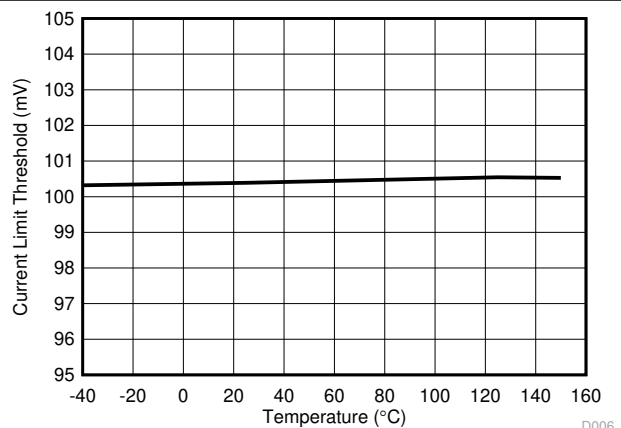

Figure 7-6. Current Limit Threshold vs Temperature

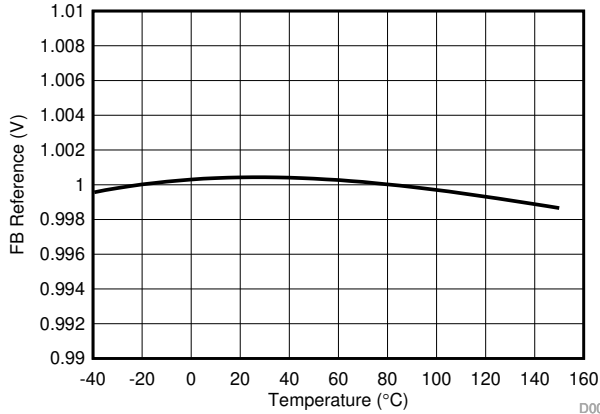

Figure 7-7. FB Reference vs Temperature

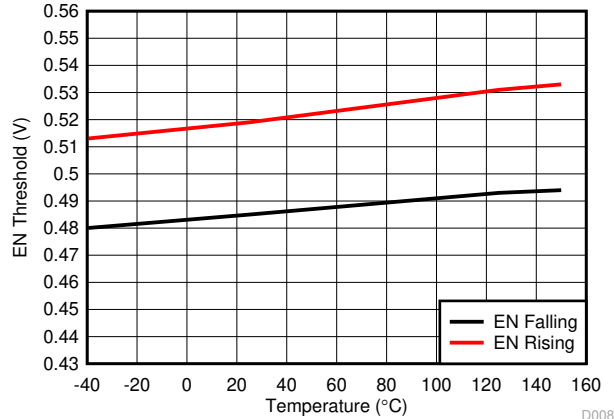

Figure 7-8. EN Threshold vs Temperature

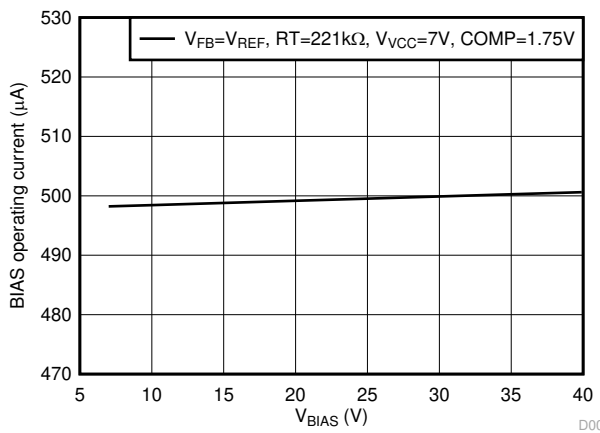

Figure 7-9. I_{OPERATING(BIAS)} Including RT Current vs V_{BIAS}

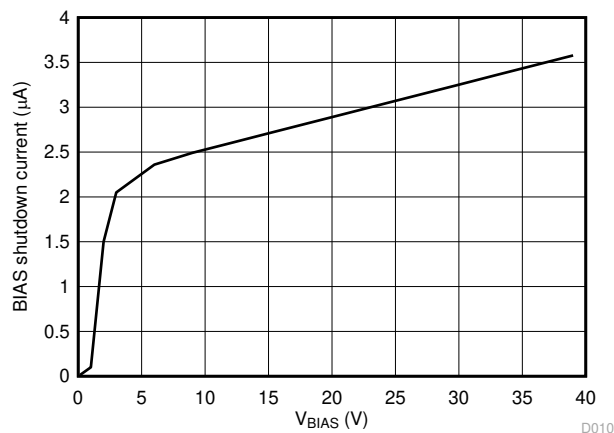

Figure 7-10. I_{SHUTDOWN(BIAS)} vs V_{BIAS}

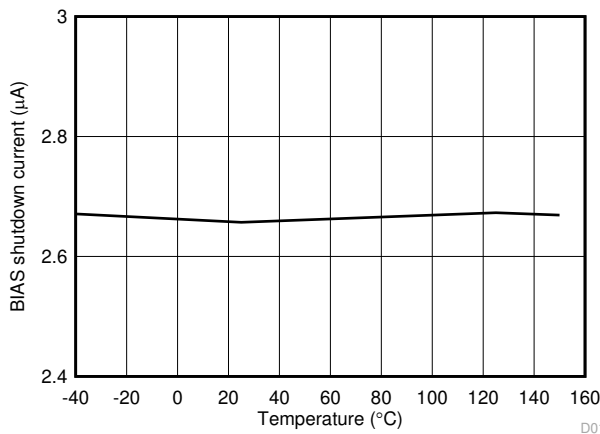

Figure 7-11. I_{SHUTDOWN} vs Temperature (BIAS = 12 V)

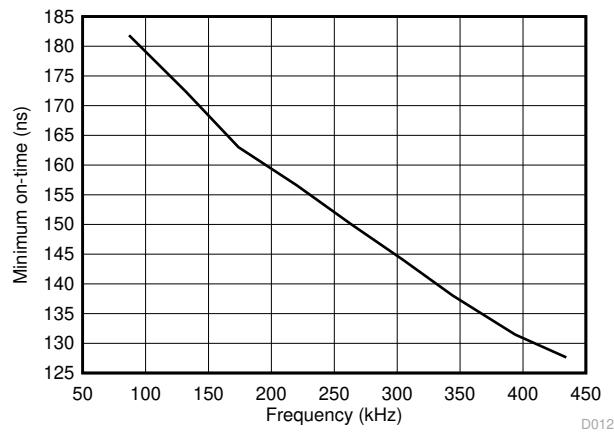

Figure 7-12. t_{ON(MIN)} vs Frequency

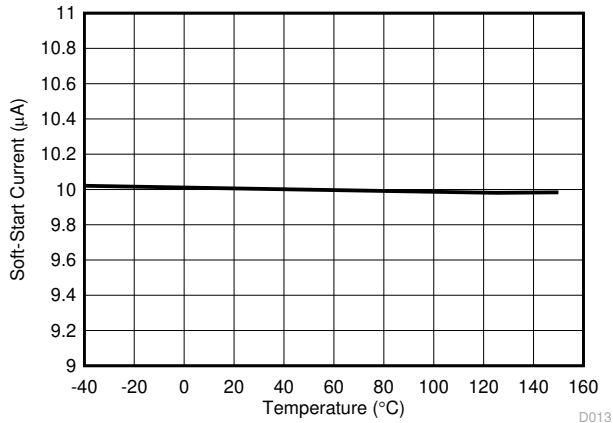

Figure 7-13. I_{SS} vs Temperature

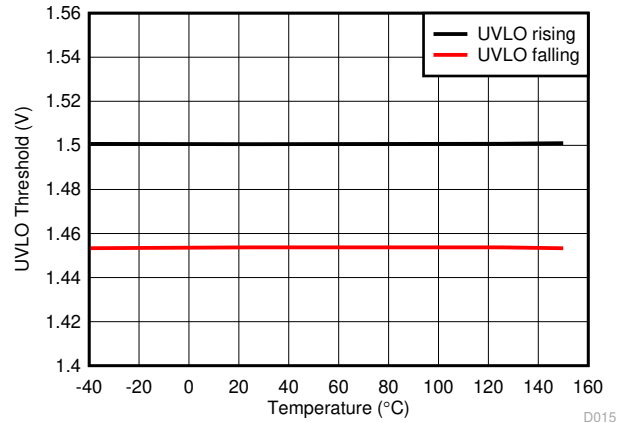

Figure 7-14. UVLO Threshold vs Temperature

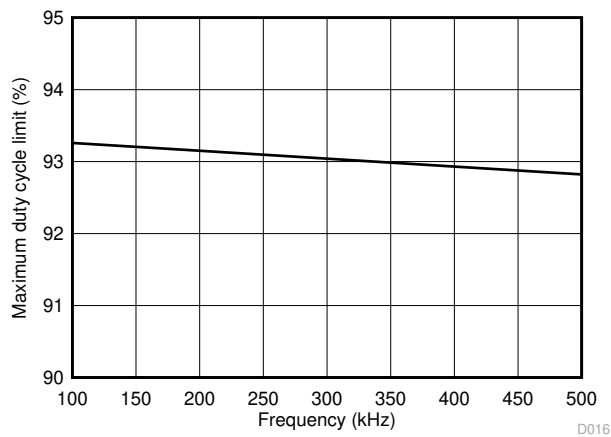

Figure 7-15. Maximum Duty Cycle vs Frequency

8 Detailed Description

8.1 Overview

The LM34966-Q1 is a wide input range, non-synchronous boost controller that uses peak-current-mode control. The device can be used in boost, SEPIC, and flyback topologies.

The device can start up from a 1-cell battery with a minimum of 2.97 V if the BIAS pin is connected to the VCC pin. It can operate with the input supply voltage as low as 1.5 V if the BIAS pin is greater than 3.5 V. The internal VCC regulator also supports BIAS pin operation up to 40 V (45-V absolute maximum) for automotive load dump. The switching frequency is dynamically programmable with an external resistor from 100 kHz to 500 kHz.

The device features a 1.0-A standard MOSFET driver and a low 100-mV current limit threshold. The device also supports the use of an external VCC supply to improve efficiency. Low operating current and pulse skipping operation improve efficiency at light loads.

The device has built-in protection features such as cycle-by-cycle current limit, overvoltage protection, line UVLO, thermal shutdown, and hiccup mode overload protection. Additional features include low shutdown I_Q , programmable soft start, programmable slope compensation, precision reference, power good indicator, and external clock synchronization.

8.2 Functional Block Diagram

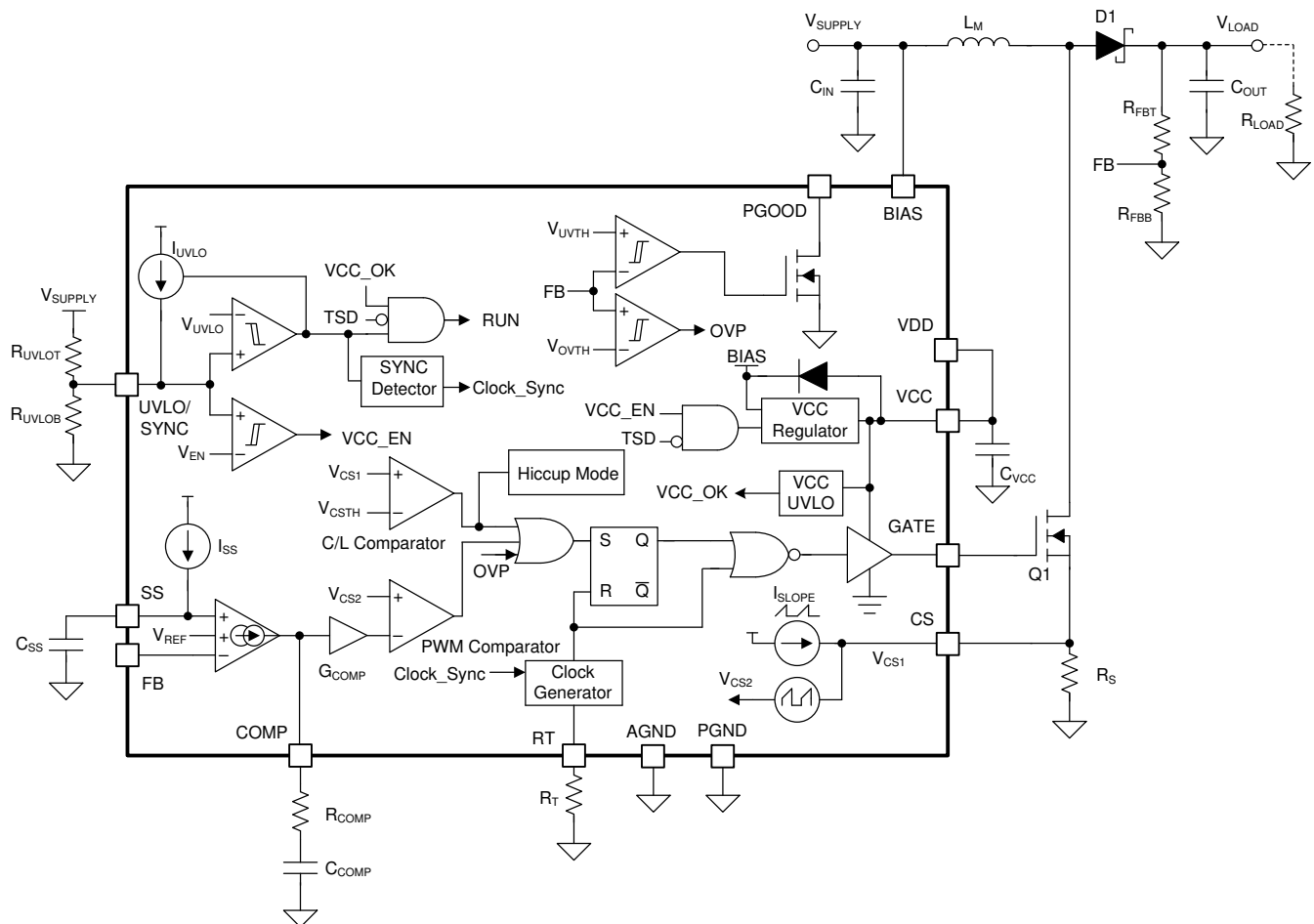

8.3 Feature Description

8.3.1 Line Undervoltage Lockout (UVLO/SYNC/EN Pin)

The device has a dual-level UVLO circuit. During power-on, if the BIAS pin voltage is greater than 2.7 V, and the UVLO pin voltage is in between the enable threshold (V_{EN}) and the UVLO threshold (V_{UVLO}) for more than 1.5 μs (see [Section 8.3.5](#) for more details), the device starts up and an internal configuration starts. The device typically requires a 65- μs internal start-up delay before entering standby mode. In standby mode, VCC regulator and RT regulator are operational, SS pin is grounded, and no switching at the GATE output.

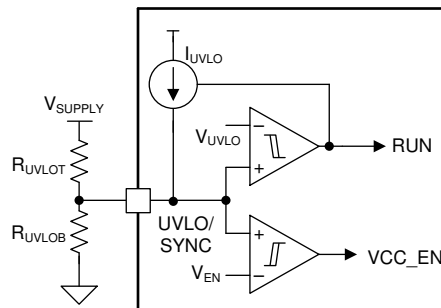

Figure 8-1. Line UVLO and Enable

When the UVLO pin voltage is above the UVLO threshold, the device enters run mode. In run mode, a soft-start sequence starts if the VCC voltage is greater than 4.5 V, or 50 μs after the VCC voltage exceeds the 2.85-V VCC UV threshold ($V_{VCC-UVLO}$), whichever comes first. UVLO hysteresis is accomplished with an internal 50-mV voltage hysteresis and an additional 5- μA current source that is switched on or off. When the UVLO pin voltage exceeds the UVLO threshold, the current source is enabled to quickly raise the voltage at the UVLO pin. When the UVLO pin voltage falls below the UVLO threshold, the current source is disabled causing the voltage at the UVLO pin to fall quickly. When the UVLO pin voltage is less than the enable threshold (V_{EN}), the device enters shutdown mode after a 35- μs (typical) delay with all functions disabled.

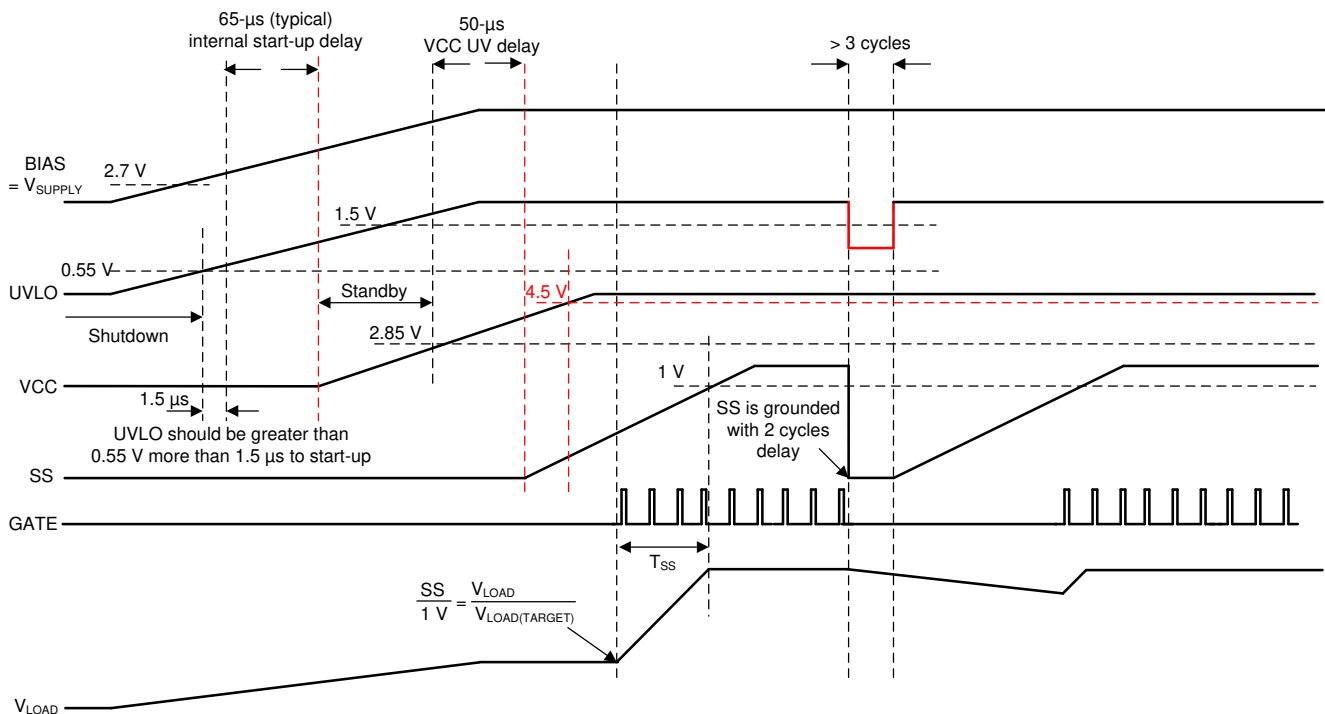

Figure 8-2. Boost Start-Up Waveforms Case 1: Start-Up by 2.85-V VCC UVLO, UVLO Toggle After Start-Up

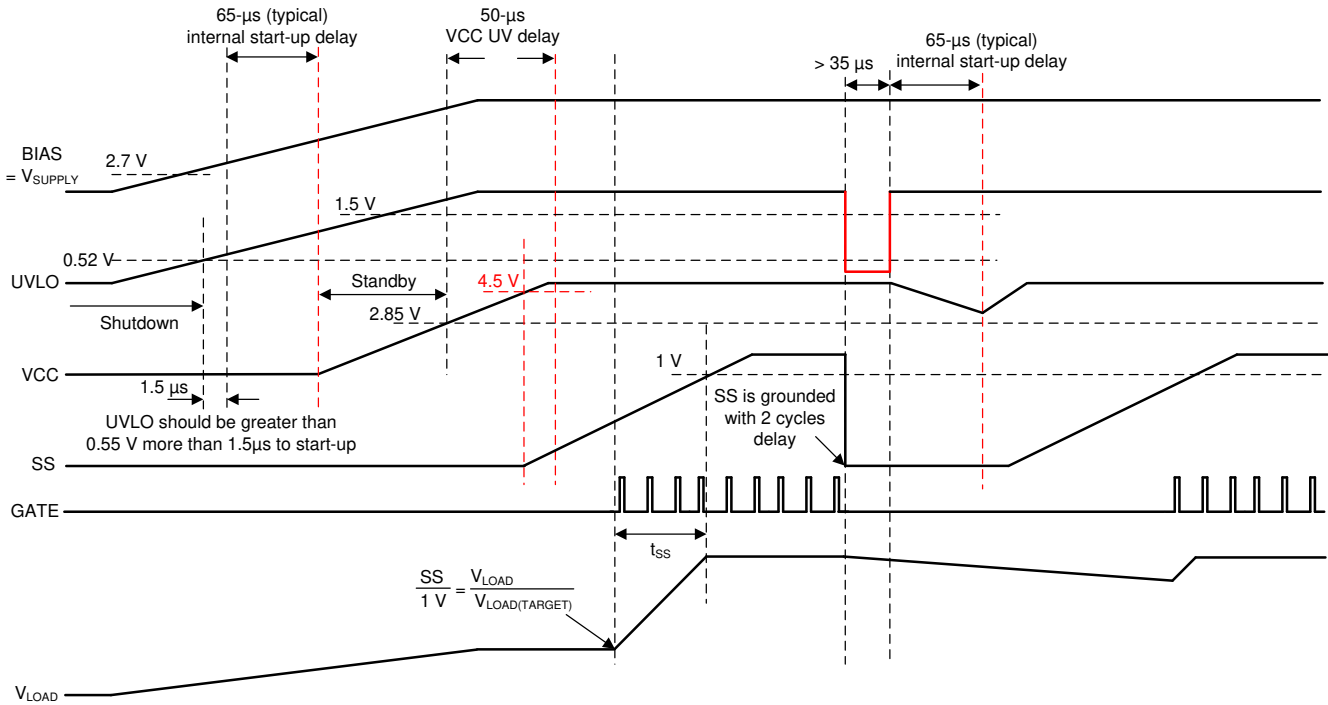

Figure 8-3. Boost Start-Up Waveforms Case2: Start-Up When VCC > 4.5 V, EN Toggle After Start-Up

The external UVLO resistor divider must be designed so that the voltage at the UVLO pin is greater than 1.5 V (typical) when the input voltage is in the desired operating range. The values of R_{UVLOT} and R_{UVLOB} can be calculated as shown in [Equation 1](#) and [Equation 2](#).

$$R_{UVLOT} = \frac{V_{SUPPLY(ON)} \times \frac{V_{UVLO(FALLING)}}{V_{UVLO(RISING)}} - V_{SUPPLY(OFF)}}{I_{UVLO}} \quad (1)$$

where

- $V_{SUPPLY(ON)}$ is the desired start-up voltage of the converter.
- $V_{SUPPLY(OFF)}$ is the desired turnoff voltage of the converter.

$$R_{UVLOB} = \frac{V_{UVLO(RISING)} \times R_{UVLOT}}{V_{SUPPLY(ON)} - V_{UVLO(RISING)}} \quad (2)$$

UVLO capacitor (C_{UVLO}) is required in case the input voltage drops below the $V_{SUPPLY(OFF)}$ momentarily during the start-up or during a severe load transient at the low input voltage. If the required UVLO capacitor is large, an additional series UVLO resistor (R_{UVLOS}) can be used to quickly raise the voltage at the UVLO pin when the 5- μ A hysteresis current turns on.

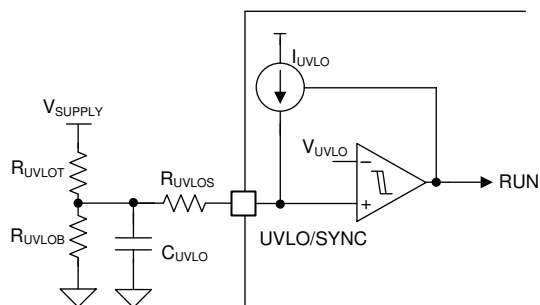

Figure 8-4. Line UVLO using Three UVLO Resistors

Do not leave the UVLO pin floating. Connect to the BIAS pin if not used.

8.3.2 High Voltage VCC Regulator (BIAS, VCC Pin)

The device has an internal wide input VCC regulator which is sourced from the BIAS pin. The wide input VCC regulator allows the BIAS pin to be connected directly to supply voltages from 3.5 V to 40 V.

The VCC regulator turns on when the device is in standby or run mode. When the BIAS pin voltage is below the VCC regulation target, the VCC output tracks the BIAS with a small dropout voltage. When the BIAS pin voltage is greater than the VCC regulation target, the VCC regulator provides 6.85-V supply for the N-channel MOSFET driver.

The VCC regulator sources current into the capacitor connected to the VCC pin with a minimum of 35-mA capability. The recommended VCC capacitor value is from 1 μ F to 4.7 μ F.

The device supports a wide input range from 3.5 V to 40 V in normal configuration. By connecting the BIAS pin directly to the VCC pin, the device supports inputs from 2.97 V to 16 V. This configuration is recommended when the device starts up from a 1-cell battery.

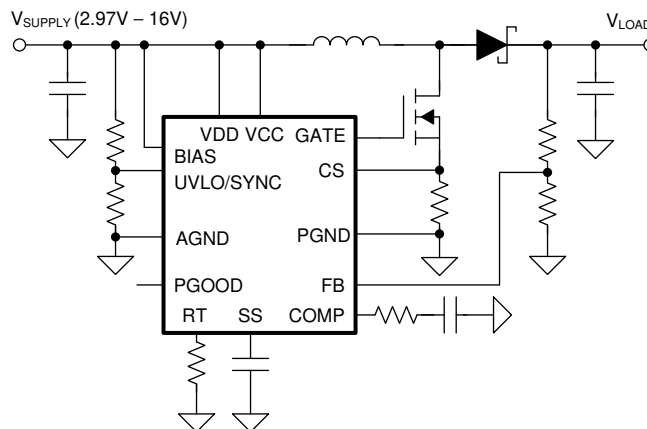

Figure 8-5. 2.97-V Start-Up (BIAS = VCC)

The minimum supply voltage after start-up can be further decreased by supplying the BIAS pin from the boost converter output or from an external power supply as shown in [Figure 8-6](#).

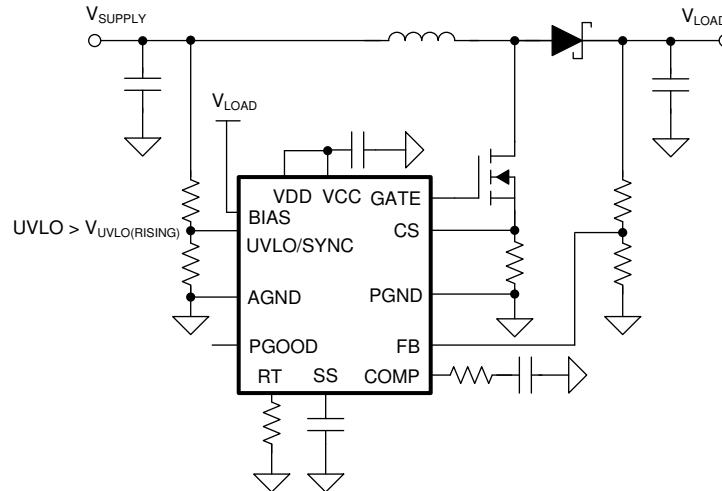

Figure 8-6. Decrease the Minimum Operating Voltage After Start-Up

In flyback topology, the internal power dissipation of the device can be decreased by supplying the VCC using an additional transformer winding. In this configuration, the external VCC supply voltage must be greater than the VCC regulation target ($V_{VCC-REG}$), and the BIAS pin voltage must be greater the VCC voltage because the VCC regulator includes a diode between VCC and BIAS.

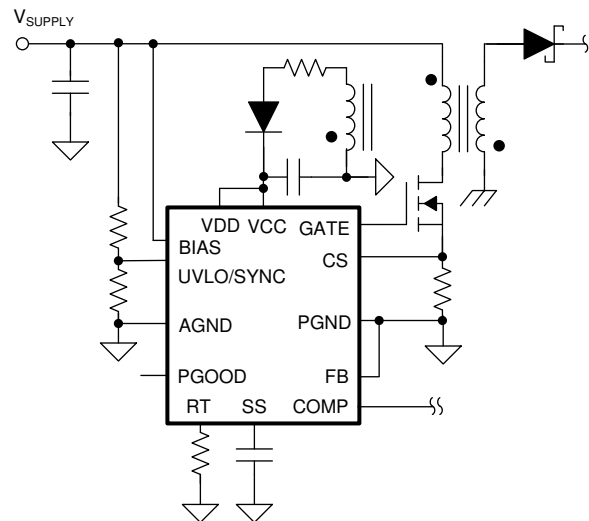

Figure 8-7. External VCC Supply (BIAS \geq VCC)

If the voltage of the external VCC bias supply is greater than the BIAS pin voltage, use an external blocking diode from the input power supply to the BIAS pin to prevent the external bias supply from passing current to the boost input supply through VCC.

8.3.3 Soft Start (SS Pin)

The soft-start feature helps the converter gradually reach the steady state operating point, thus reducing start-up stresses and surges. The device regulates the FB pin to the SS pin voltage or the internal reference, whichever is lower.

At start-up, the internal 10- μ A soft-start current source (I_{SS}) turns on 50 μ s after the VCC voltage exceeds the 2.85-VCC UV threshold, or if the VCC voltage is greater than 4.5 V, whichever comes first. The soft-start current gradually increases the voltage on an external soft-start capacitor connected to the SS pin. This results in a gradual rise of the output voltage. The SS pin is pulled down to ground by an internal switch when the VCC is

less than VCC UVLO threshold, the UVLO is less than the UVLO threshold, during hiccup mode off-time or thermal shutdown.

In boost topology, soft-start time (t_{SS}) varies with the input supply voltage. The soft-start time in boost topology is calculated as shown in Equation 3.

$$t_{SS} = \frac{C_{SS}}{I_{SS}} \times \left(1 - \frac{V_{SUPPLY}}{V_{LOAD}} \right) \quad (3)$$

In SEPIC topology, the soft-start time (t_{SS}) is calculated as follows.

$$t_{SS} = \frac{C_{SS}}{I_{SS}} \quad (4)$$

TI recommends choosing the soft-start time long enough so that the converter can start up without going into an overcurrent state. See Section 8.3.10 for more detailed information.

Figure 8-8 shows an implementation of primary side soft-start in flyback topology.

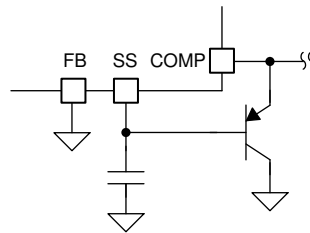

Figure 8-8. Primary-Side Soft-Start in Flyback

Figure 8-9 shows an implementation of secondary side soft start in flyback topology.

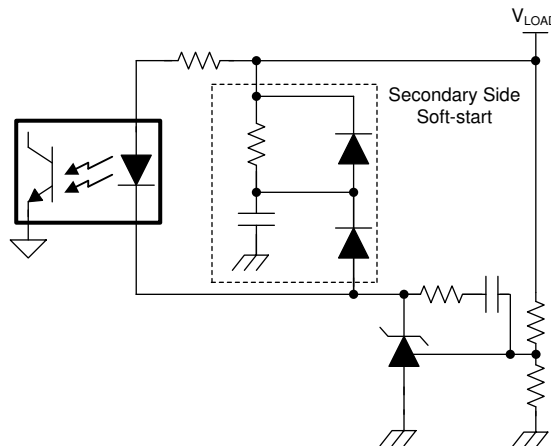

Figure 8-9. Secondary-Side Soft Start in Flyback

8.3.4 Switching Frequency (RT Pin)

The switching frequency of the device can be set by a single RT resistor connected between the RT and the AGND pins. The resistor value to set the RT switching frequency (f_{RT}) is calculated as shown in Equation 5.

$$R_T = \frac{2.21 \times 10^{10}}{f_{RT(TYPICAL)}} - 955 \quad (5)$$

The RT pin is regulated to 0.5 V by the internal RT regulator when the device is enabled.

8.3.5 Clock Synchronization (UVLO/SYNC/EN Pin)

The switching frequency of the device can be synchronized to an external clock by pulling down the UVLO/SYNC pin. The internal clock of the device is synchronized at the falling edge, but ignores the falling edge input during the forced off-time which is determined by the maximum duty cycle limit. The external synchronization clock must pull down the UVLO/SYNC pin voltage below 1.45 V (typical). The duty cycle of the pulldown pulse is not limited, but the minimum pulldown pulse width must be greater than 150 ns, and the minimum pullup pulse width must be greater than 250 ns. [Figure 8-10](#) shows an implementation of the remote shutdown function. The UVLO pin can be pulled down by a discrete MOSFET or an open-drain output of an MCU. In this configuration, the device stops switching immediately after the UVLO pin is grounded, and the device shuts down 35 μ s (typical) after the UVLO pin is grounded.

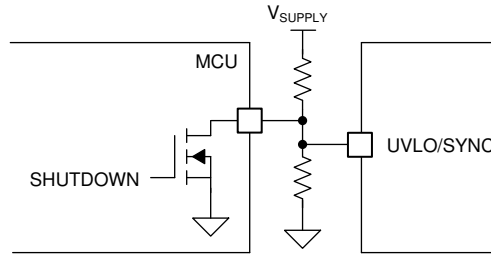

Figure 8-10. UVLO and Shutdown

[Figure 8-11](#) shows an implementation of shutdown and clock synchronization functions together. In this configuration, the device stops switching immediately when the UVLO pin is grounded, and the device shuts down if f_{SYNC} stays in high logic state for longer than 35 μ s (typical) (UVLO is in low logic state for more than 35 μ s (typical)). The device runs at the f_{SYNC} if clock pulses are provided after the device is enabled.

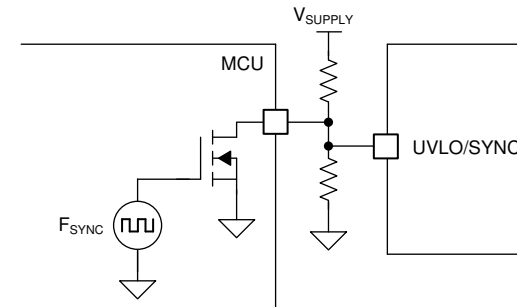

Figure 8-11. UVLO, Shutdown, and Clock Synchronization

[Figure 8-13](#) and [Figure 8-14](#) show implementations of standby and clock synchronization functions together. In this configuration, the device stops switching immediately if f_{SYNC} stays in high logic state and enters standby mode if f_{SYNC} stays in high logic state for longer than two switching cycles. The device runs at f_{SYNC} if clock pulses are provided. Because the device can be enabled when the UVLO pin voltage is greater than the enable threshold for more than 1.5 μ s, the configurations in [Figure 8-13](#) and [Figure 8-14](#) are recommended if the external clock synchronization pulses are provided from the start before the device is enabled. This 1.5- μ s requirement can be relaxed when the duty cycle of the synchronization pulse is greater than 50%. [Figure 8-12](#) shows the required minimum duty cycle to start up by synchronization pulses.

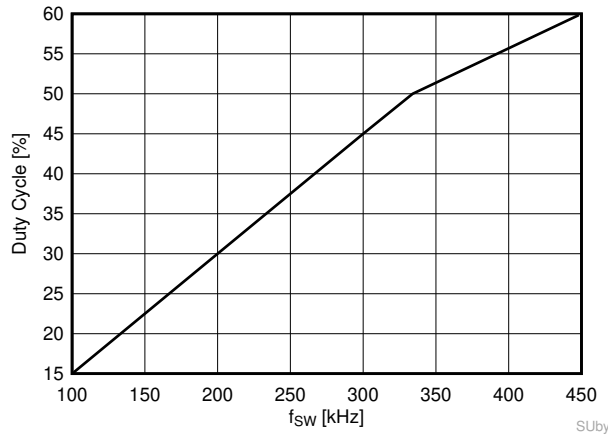

Figure 8-12. Required Duty Cycle to Start Up by SYNC

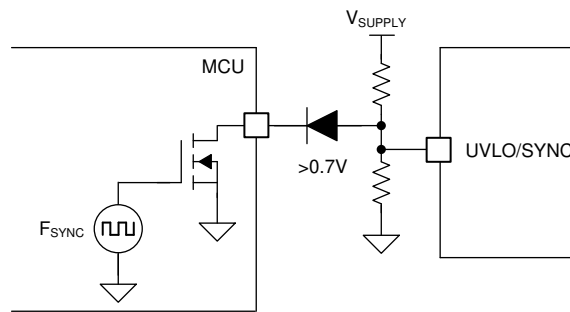

Figure 8-13. UVLO, Standby, and Clock Synchronization (a)

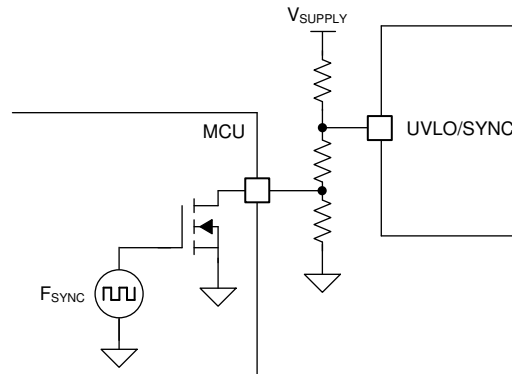

Figure 8-14. UVLO, Standby, and Clock Synchronization (b)

If the UVLO function is not required, the shutdown and clock synchronization functions can be implemented together by using one push-pull output of the MCU. In this configuration, the device shuts down if f_{SYNC} stays in low logic state for longer than 35 μs (typical). The device is enabled if f_{SYNC} stays in high logic state for longer than 1.5 μs . The device runs at the f_{SYNC} if clock pulses are provided after the device is enabled. Also, in this configuration, it is recommended to apply the external clock pulses after the BIAS is supplied. By limiting the current flowing into the UVLO pin below 1 mA using a current limiting resistor, the external clock pulses can be supplied before the BIAS is supplied (see [Figure 8-15](#)).

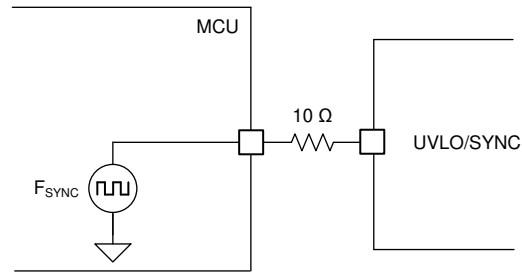

Figure 8-15. Shutdown and Clock Synchronization

Figure 8-16 shows an implementation of inverted enable using external circuit.

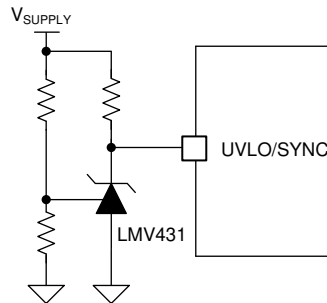

Figure 8-16. Inverted UVLO

The external clock frequency (f_{SYNC}) must be within +25% and -30% of $f_{\text{RT(TYPICAL)}}$. Because the maximum duty cycle limit and the peak current limit with slope resistor (R_{SL}) are affected by the clock synchronization, take extra care when using the clock synchronization function. See [Section 8.3.6](#), [Section 8.3.7](#), and [Section 8.3.11](#) for more information.

8.3.6 Current Sense and Slope Compensation (CS Pin)

The device has a low-side current sense and provides both fixed and optional programmable slope compensation ramps, which help to prevent subharmonic oscillation at high duty cycle. Both fixed and programmable slope compensation ramps are added to the sensed inductor current input for the PWM operation. But, only the programmable slope compensation ramp is added to the sensed inductor current input (see [Figure 8-17](#)). For an accurate peak current limit operation over the input supply voltage, TI recommends using only the fixed slope compensation (see [Figure 7-5](#)).

The device can generate the programmable slope compensation ramp using an external slope resistor (R_{SL}) and a sawtooth current source with a slope of $30 \mu\text{A} \times f_{\text{RT}}$. This current flows out of the CS pin.

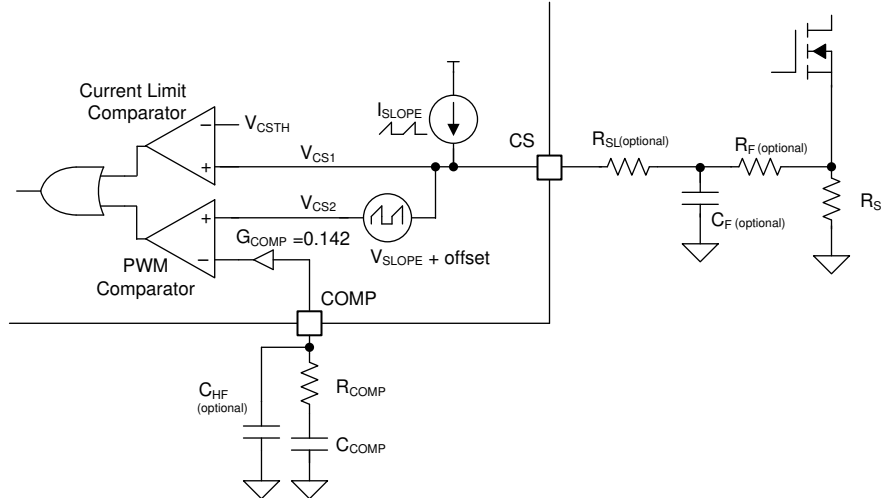

Figure 8-17. Current Sensing and Slope Compensation

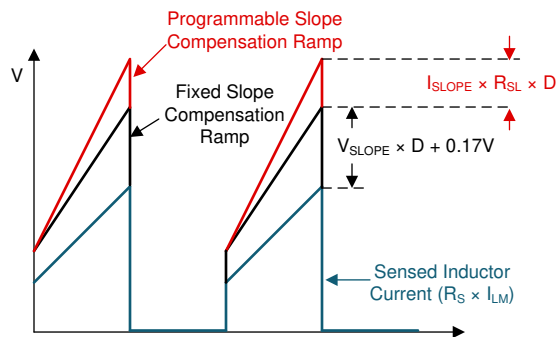

Figure 8-18. Slope Compensation Ramp (a) at PWM Comparator Input

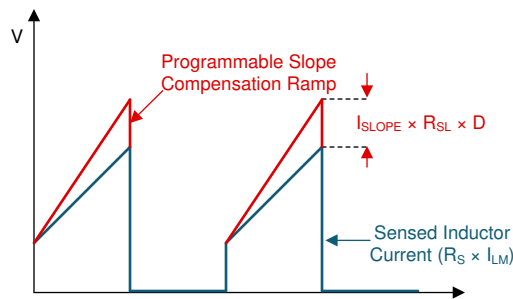

Figure 8-19. Slope Compensation Ramp (b) at Current Limit Comparator Input

Use [Equation 6](#) to calculate the value of the peak slope current (I_{SLOPE}) and use [Equation 7](#) to calculate the value of the peak slope voltage (V_{SLOPE}).

$$I_{SLOPE} = 30\mu A \times \frac{f_{RT}}{f_{SYNC}} \quad (6)$$

$$V_{SLOPE} = 40mV \times \frac{f_{RT}}{f_{SYNC}} \quad (7)$$

where

- $f_{\text{SYNC}} = f_{\text{RT}}$ if clock synchronization is not used.

According to peak current mode control theory, the slope of the compensation ramp must be greater than half of the sensed inductor current falling slope to prevent subharmonic oscillation at high duty cycle. Therefore, the minimum amount of slope compensation in boost topology should satisfy the following inequality:

$$0.5 \times \frac{(V_{\text{LOAD}} + V_{\text{F}}) - V_{\text{SUPPLY}}}{L_{\text{M}}} \times R_{\text{S}} \times \text{Margin} < 40\text{mV} \times f_{\text{SW}} \quad (8)$$

where

- V_{F} is a forward voltage drop of D1, the external diode.

The recommended margin to cover non-ideal factors is 1.2. If required, R_{SL} can be added to further increase the slope of the compensation ramp. Typically 82% of the sensed inductor current falling slope is known as an optimal amount of the slope compensation. The R_{SL} value to achieve 82% of the sensed inductor current falling slope is calculated as shown in Equation 9.

$$0.82 \times \frac{(V_{\text{LOAD}} + V_{\text{F}}) - V_{\text{SUPPLY}}}{L_{\text{M}}} \times R_{\text{S}} = (30\mu\text{A} \times R_{\text{SL}} + 40\text{mV}) \times f_{\text{SW}} \quad (9)$$

If clock synchronization is not used, the f_{SW} frequency equals the f_{RT} frequency. If clock synchronization is used, the f_{SW} frequency equals the f_{SYNC} frequency. The maximum value for the R_{SL} resistance is 2 k Ω .

8.3.7 Current Limit and Minimum On-time (CS Pin)

The device provides cycle-by-cycle peak current limit protection that turns off the MOSFET when the sum of the inductor current and the programmable slope compensation ramp reaches the current limit threshold (V_{CLTH}). Peak inductor current limit ($I_{\text{PEAK-CL}}$) in steady state is calculated as shown in Equation 10.

$$I_{\text{PEAK-CL}} = \frac{V_{\text{CLTH}} - 30\mu\text{A} \times R_{\text{SL}} \times \frac{f_{\text{RT}}}{f_{\text{SYNC}}} \times D}{R_{\text{S}}} \quad (10)$$

The practical duty cycle is greater than the estimated due to voltage drops across the MOSFET and sense resistor. The estimated duty cycle is calculated as shown in Equation 11.

$$D = 1 - \frac{V_{\text{SUPPLY}}}{V_{\text{LOAD}} + V_{\text{F}}} \quad (11)$$

Boost converters have a natural pass-through path from the supply to the load through the high-side power diode (D1). Because of this path and the minimum on-time limitation of the device, boost converters cannot provide current limit protection when the output voltage is close to or less than the input supply voltage. The minimum on-time is shown in Figure 7-12 and is calculated as Equation 12.

$$t_{\text{ON(MIN)}} \approx \frac{800 \times 10^{-15}}{\frac{1}{8 \times R_{\text{T}}} + 4 \times 10^{-6}} \quad (12)$$

If required, a small external RC filter (R_F , C_F) at the CS pin can be added to overcome the large leading edge spike of the current sense signal. Select an R_F value which is in the range of 10 Ω to 200 Ω and a C_F value in the range of 100 pF to 2 nF. Because of the effect of this RC filter, the peak current limit is not valid when the on-time is less than $2 \times R_F \times C_F$. To fully discharge the C_F during the off-time, the RC time constant should satisfy the following inequality.

$$3 \times R_F \times C_F < \frac{1-D}{f_{SW}} \quad (13)$$

8.3.8 Feedback and Error Amplifier (FB, COMP Pin)

The feedback resistor divider is connected to an internal transconductance error amplifier which features high output resistance ($R_O = 10 \text{ M}\Omega$) and wide bandwidth ($BW = 7 \text{ MHz}$). The internal transconductance error amplifier sources current, which is proportional to the difference between the FB pin and the SS pin voltage or the internal reference, whichever is lower. The internal transconductance error amplifier provides symmetrical sourcing and sinking capability during normal operation and reduces its sinking capability when the FB is greater than OVP threshold.

To set the output regulation target, select the feedback resistor values as shown in [Equation 14](#).

$$V_{LOAD} = V_{REF} \times \left(\frac{R_{FBT}}{R_{FBB}} + 1 \right) \quad (14)$$

The output of the error amplifier is connected to the COMP pin, allowing the use of a Type 2 loop compensation network. R_{COMP} , C_{COMP} and optional C_{HF} loop compensation components configure the error amplifier gain and phase characteristics to achieve a stable loop response. The absolute maximum voltage rating of the FB pin is 4.0 V. If necessary, especially during automotive load dump transient, the feedback resistor divider input can be clamped with an external Zener diode.

The COMP pin features internal clamps. The maximum COMP clamp limits the maximum COMP pin voltage below its absolute maximum rating even in shutdown. The minimum COMP clamp limits the minimum COMP pin voltage in order to start switching as soon as possible during no load to heavy load transition. The minimum COMP clamp is disabled when FB is connected to ground in flyback topology.

8.3.9 Power-Good Indicator (PGOOD Pin)

The device has a power-good indicator (PGOOD) to simplify sequencing and supervision. The PGOOD switches to a high impedance open-drain state when the FB pin voltage is greater than the feedback under voltage threshold (V_{UVTH}), the VCC is greater than the VCC UVLO threshold and the UVLO/EN is greater than the EN threshold. A 25- μs deglitch filter prevents any false pulldown of the PGOOD due to transients. The recommended minimum pullup resistor value is 10 k Ω .

Due to the internal diode path from the PGOOD pin to the BIAS pin, the PGOOD pin voltage cannot be greater than $V_{BIAS+} + 0.3 \text{ V}$.

8.3.10 Hiccup Mode Overload Protection

To further protect the converter during prolonged current limit conditions, the device provides a hiccup mode overload protection. The internal hiccup mode fault timer of the device counts the PWM clock cycles when the cycle-by-cycle current limiting occurs after soft-start is finished. When the hiccup mode fault timer detects 64 cycles of current limiting, an internal hiccup mode off timer forces the device to stop switching and pulls down SS. Then, the device will restart after 32,768 cycles of hiccup mode off-time. The 64 cycle hiccup mode fault timer is reset if eight consecutive switching cycles occur without exceeding the current limit threshold. The soft-start time must be long enough not to trigger the hiccup mode protection after the soft-start is finished.

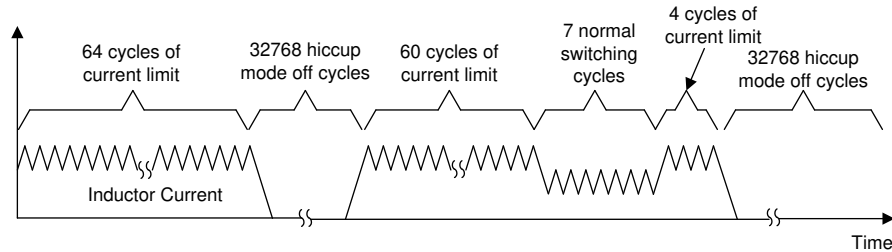

Figure 8-20. Hiccup Mode Overload Protection

To avoid an unexpected hiccup mode operation during a harsh load transient condition, it is recommended to have more margin when programming the peak-current limit.

8.3.11 Maximum Duty Cycle Limit and Minimum Input Supply Voltage

When designing boost converters, the maximum duty cycle should be reviewed at the minimum supply voltage. The minimum input supply voltage that can achieve the target output voltage is limited by the maximum duty cycle limit, and it can be estimated as follows.

$$V_{\text{SUPPLY(MIN)}} \approx (V_{\text{LOAD}} + V_F) \times (1 - D_{\text{MAX}}) + I_{\text{SUPPLY(MAX)}} \times R_{\text{DCR}} + I_{\text{SUPPLY(MAX)}} \times (R_{\text{DS(ON)}} + R_S) \times D_{\text{MAX}} \quad (15)$$

where

- $I_{\text{SUPPLY(MAX)}}$ is the maximum input current.
- R_{DCR} is the DC resistance of the inductor.
- $R_{\text{DS(ON)}}$ is the on-resistance of the MOSFET.

$$D_{\text{MAX1}} = 1 - 0.1 \times \frac{f_{\text{SYNC}}}{f_{\text{RT}}} \quad (16)$$

$$D_{\text{MAX2}} = 1 - 100\text{ns} \times f_{\text{SW}} \quad (17)$$

The minimum input supply voltage can be further decreased by supplying f_{SYNC} which is less than f_{RT} . D_{MAX} is D_{MAX1} or D_{MAX2} , whichever is lower.

8.3.12 MOSFET Driver (GATE Pin)

The device provides an N-channel MOSFET driver that can source or sink a peak current of 1.0 A. The peak sourcing current is larger when supplying an external VCC that is higher than 6.75 V VCC regulation target. During start-up, especially when the input voltage range is below the VCC regulation target, the VCC voltage must be sufficient to completely enhance the MOSFET. If the MOSFET drive voltage is lower than the MOSFET gate plateau voltage during start-up, the boost converter may not start up properly and it can stick at the maximum duty cycle in a high power dissipation state. This condition can be avoided by selecting a lower threshold N-channel MOSFET switch and setting the $V_{\text{SUPPLY(ON)}}$ greater than 6 to 7 V. Because the internal VCC regulator has a limited sourcing capability, the MOSFET gate charge should satisfy the following inequality.

$$Q_{\text{G@VCC}} \times f_{\text{SW}} < 20 \text{ mA} \quad (18)$$

An internal 1-M Ω resistor is connected between GATE and PGND to prevent a false turnon during shutdown. In boost topology, switch node dV/dT must be limited during the 65- μs internal start-up delay to avoid a false turn-on, which is caused by the coupling through C_{DG} parasitic capacitance of the MOSFET.

8.3.13 Overvoltage Protection (OVP)

The device has OVP for the output voltage. OVP is sensed at the FB pin. If the voltage at the FB pin rises above the overvoltage threshold (V_{OVTH}), OVP is triggered and switching stops. During OVP, the internal error amplifier is operational, but the maximum source and sink capability is decreased to 40 μ A.

8.3.14 Thermal Shutdown (TSD)

An internal thermal shutdown turns off the VCC regulator, disables switching and pulls down the SS when the junction temperature exceeds the thermal shutdown threshold (T_{TSD}). After the temperature is decreased by 15°C, the VCC regulator is enabled again and the device performs a soft start.

8.4 Device Functional Modes

8.4.1 Shutdown Mode

If the UVLO pin voltage is below the enable threshold for longer than 35 μ s (typical), the device goes to the shutdown mode with all functions disabled. In shutdown mode, the device decreases the BIAS pin current consumption to below 2.6 μ A (typical).

8.4.2 Standby Mode

If the UVLO pin voltage is greater than the enable threshold and below the UVLO threshold for longer than 1.5 μ s, the device is in standby mode with the VCC regulator operational, RT regulator operational, SS pin grounded, and no switching at the GATE output. The PGOOD is activated when the VCC voltage is greater than the VCC UV threshold.

8.4.3 Run Mode

If the UVLO pin voltage is above the UVLO threshold and the VCC voltage is sufficient, the device enters RUN mode. In this mode, soft start starts 50 μ s after the VCC voltage exceeds the 2.85 VCC UV threshold, or if the VCC voltage is greater than 4.5 V, whichever comes first.

9 Application and Implementation

Note

Information in the following applications sections is not part of the TI component specification, and TI does not warrant its accuracy or completeness. TI's customers are responsible for determining suitability of components for their purposes. Customers should validate and test their design implementation to confirm system functionality.

9.1 Power-On Hours (POH)

The device is capable of operating at a wide temperature range including high junction temperature up to 150°C. It is designed to meet or exceed AEC-Q100 grade 1 specifications by accommodating additional IC junction temperature rise while operating at 125°C ambient temperature. The electrical specifications of the device is fully characterized between T_J of -40°C to 150°C to support automotive and other high junction temperature applications. Extended reliability test data beyond AEC-Q100 grade 1 specification is also available upon request.

The device is capable of supporting product lifetime operation temperature profiles typical to many automotive applications. [Table 9-1](#) shows an example of an application with 19340 POH at an input bias voltage of 40 V. The life span of a semiconductor device is a function of bias conditions, operating temperatures, and power-on time. Extended operation at high junction temperature degrades the product total power-on hours.

Table 9-1. POH Breakdown

JUNCTION TEMPERATURE	POWER-ON HOURS	DISTRIBUTION	OPERATING CONDITIONS
-15°C	720 Hours	3.7%	BIAS = 40 V $E_a = 0.7\text{eV}$
48°C	6300 Hours	32.6%	
101°C	11000 Hours	56.9%	
145°C	1200 Hours	6.2%	
150°C	120 Hours	0.6%	

9.2 Application Information

[How to Design a Boost Converter Using LM5156x](#) explains how to design boost converter using the device. This comprehensive application note includes component selections and loop response optimization.

9.3 Typical Application

[Figure 9-1](#) shows all optional components to design a boost converter.

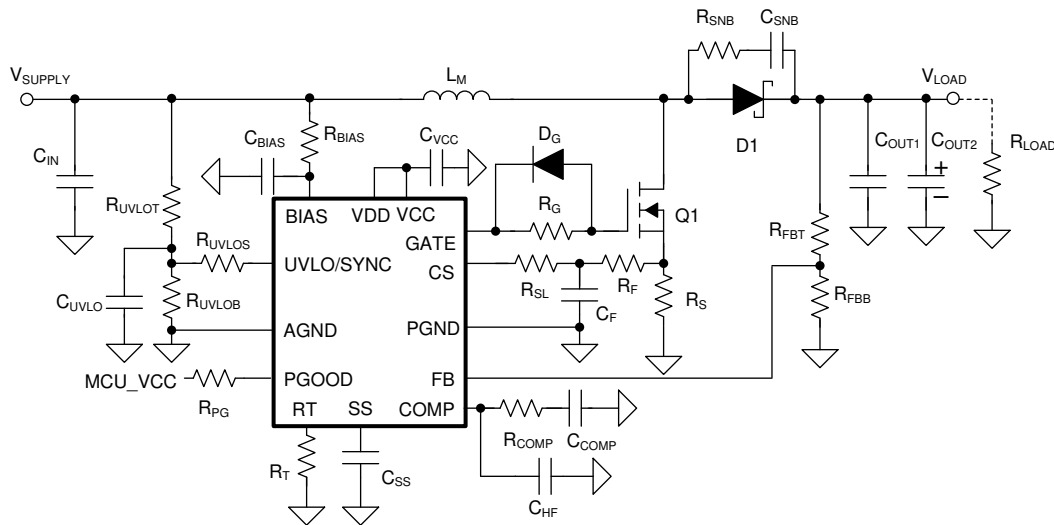

Figure 9-1. Typical Boost Converter Circuit With Optional Components

9.3.1 Design Requirements

Table 9-2 shows the intended input, output, and performance parameters for this application example.

Table 9-2. Design Example Parameters

DESIGN PARAMETER	VALUE
Minimum input supply voltage ($V_{SUPPLY(MIN)}$)	6 V
Target output voltage (V_{LOAD})	24 V
Maximum load current (I_{LOAD})	2 A (\approx 48 Watt)
Typical switching frequency (f_{SW})	440 kHz

9.3.2 Detailed Design Procedure

Use the Quick Start Calculator to expedite the process of designing of a regulator for a given application based on the device. Download the Quick Start Calculator for more information on loop response and component selection

- [LM5155x / LM5156x Boost Quick Start Calculator](#)

The device is also WEBENCH® Designer enabled. The WEBENCH software uses an iterative design procedure and accesses comprehensive data bases of components when generating a design.

9.3.2.1 Custom Design With WEBENCH® Tools

[Click here](#) to create a custom design using the LM34966-Q1 device with the WEBENCH® Power Designer.

1. Start by entering the input voltage (V_{IN}), output voltage (V_{OUT}), and output current (I_{OUT}) requirements.
2. Optimize the design for key parameters such as efficiency, footprint, and cost using the optimizer dial.
3. Compare the generated design with other possible solutions from Texas Instruments.

The WEBENCH Power Designer provides a customized schematic along with a list of materials with real-time pricing and component availability.

In most cases, these actions are available:

- Run electrical simulations to see important waveforms and circuit performance
- Run thermal simulations to understand board thermal performance
- Export customized schematic and layout into popular CAD formats
- Print PDF reports for the design, and share the design with colleagues

Get more information about WEBENCH tools at www.ti.com/WEBENCH.

9.3.2.2 Recommended Components

Table 9-3 shows a recommended list of materials for this typical application.

Table 9-3. List of Materials

REFERENCE DESIGNATOR	QTY.	SPECIFICATION	MANUFACTURER (1)	PART NUMBER
R _T	1	RES, 49.9 k, 1%, 0.1 W, AEC-Q200 Grade 0, 0603	Vishay-Dale	CRCW060349K9FKEA
R _{FBT}	1	RES, 47.0 k, 1%, 0.1 W, AEC-Q200 Grade 0, 0603	Vishay-Dale	CRCW060347K0FKEA
R _{FBB}	1	RES, 2.0 k, 5%, 0.1 W, AEC-Q200 Grade 0, 0603	Vishay-Dale	CRCW06032K00JNEA
L _M	1	Inductor, Shielded, Composite, 6.8 μH, 18.5 A, 0.01 Ω, SMD	Coilcraft	XAL1010-682MEB
R _S	1	RES, 0.008, 1%, 3 W, AEC-Q200 Grade 0, 2512 WIDE	Susumu	KRL6432E-M-R008-F-T1
R _{SL}	1	RES, 0, 5%, 0.1 W, 0603	Yageo America	RC0603JR-070RL
C _{OUT1}	3	CAP, CERM, 4.7 μF, 50 V, ±10%, X7R, 1210	TDK	C3225X7R1H475K250AB
C _{OUT2} (Bulk)	2	CAP, Aluminum Polymer, 100 μF, 50 V, ±20%, 0.025 Ω, AEC-Q200 Grade 2, D10xL10mm SMD	Chemi-Con	HHXB500ARA101MJA0G
C _{IN1}	6	CAP, CERM, 10 μF, 50 V, ±10%, X7R, 1210	MuRata	GRM32ER71H106KA12L
C _{IN2} (Bulk)	1	CAP, Polymer Hybrid, 100 μF, 50 V, ±20%, 28 Ω, 10x10 SMD	Panasonic	EEHZC1H101P
Q1	1	MOSFET, N-CH, 40 V, 50 A, AEC-Q101, SON-8	Infineon	IPC50N04S5L5R5ATMA1
D1	1	Schottky, 60 V, 10 A, AEC-Q101, CFP15	Nexperia	PMEG060V100EPDZ
R _{COMP}	1	RES, 11.3 k, 1%, 0.1 W, AEC-Q200 Grade 0, 0603	Vishay-Dale	CRCW060311K3FKEA
C _{COMP}	1	CAP, CERM, 0.022 μF, 100 V, ±10%, X7R, AEC-Q200 Grade 1, 0603	TDK	CGA3E2X7R2A223K080AA
C _{HF}	1	CAP, CERM, 220 pF, 20 V, ±5%, C0G/NP0, AEC-Q200 Grade 1, 0603	TDK	CGA3E2C0G1H221J080AA
R _{UVLOT}	1	RES, 21.0 k, 1%, 0.1 W, AEC-Q200 Grade 0, 0603	Vishay-Dale	CRCW060321K0FKEA
R _{UVLOB}	1	RES, 7.32 k, 1%, 0.1 W, AEC-Q200 Grade 0, 0603	Vishay-Dale	CRCW06037K32FKEA
R _{UVLOS}	0	N/A	N/A	N/A
C _{SS}	1	CAP, CERM, 0.22 μF, 50 V, ±10%, X7R, AEC-Q200 Grade 1, 0603	TDK	CGA3E3X7R1H224K080AB
D _G	0	N/A	N/A	N/A
R _G	1	RES, 0, 5%, 0.1 W, 0603	Yageo America	RC0603JR-070RL
C _F	1	CAP, CERM, 100 pF, 50 V, ±1%, C0G/NP0, 0603	Kemet	C0603C101F5GACTU
R _F	1	RES, 100, 1%, 0.1 W, 0603	Yageo America	RC0603FR-07100RL
R _{SNB}	0	N/A	N/A	N/A
C _{SNB}	0	N/A	N/A	N/A
R _{BIAS}	1	RES, 0, 5%, 0.1 W, AEC-Q200 Grade 0, 0603	Panasonic	ERJ-3GEY0R00V
C _{BIAS}	1	CAP, CERM, 0.01 μF, 50 V, ±10%, X7R, 0603	Samsung Electro-Mechanics	CL10B103KB8NCNC
C _{VCC}	1	CAP, CERM, 1 μF, 16 V, ±20%, X7R, AEC-Q200 Grade 1, 0603	MuRata	GCM188R71C105MA64D
R _{PG}	1	RES, 24.9 k, 1%, 0.1 W, 0603	Yageo America	RC0603FR-0724K9L

(1) See [Section 12.1.1](#)

9.3.2.3 Inductor Selection (L_M)

When selecting the inductor, consider three key parameters: inductor current ripple ratio (RR), falling slope of the inductor current, and RHP zero frequency (f_{RHP}).

Inductor current ripple ratio is selected to have a balance between core loss and copper loss. The falling slope of the inductor current must be low enough to prevent subharmonic oscillation at high duty cycle (additional R_{SL}

resistor is required if not). Higher f_{RHP} (= lower inductance) allows a higher crossover frequency and is always preferred when using a small value output capacitor.

The inductance value can be selected to set the inductor current ripple between 30% and 70% of the average inductor current as a good compromise between RR, F_{RHP} and inductor falling slope.

9.3.2.4 Output Capacitor (C_{OUT})

There are a few ways to select the proper value of output capacitor (C_{OUT}). The output capacitor value can be selected based on output voltage ripple, output overshoot, or undershoot due to load transient.

The ripple current rating of the output capacitors must be enough to handle the output ripple current. By using multiple output capacitors, the ripple current can be split. In practice, ceramic capacitors are placed closer to the diode and the MOSFET than the bulk aluminum capacitors to absorb the majority of the ripple current.

9.3.2.5 Input Capacitor

The input capacitors decrease the input voltage ripple. The required input capacitor value is a function of the impedance of the source power supply. More input capacitors are required if the impedance of the source power supply is not low enough.

9.3.2.6 MOSFET Selection

The MOSFET gate driver of the device is sourced from the VCC. The maximum gate charge is limited by the 35-mA VCC sourcing current limit.

A leadless package is preferred for high switching-frequency designs. The MOSFET gate capacitance should be small enough so that the gate voltage is fully discharged during the off-time.

9.3.2.7 Diode Selection

A Schottky is the preferred type for D1 diode due to its low forward voltage drop and small reverse recovery charge. Low reverse leakage current is important parameter when selecting the Schottky diode. The diode must be rated to handle the maximum output voltage plus any switching node ringing. Also, it must be able to handle the average output current.

9.3.2.8 Efficiency Estimation

The total loss of the boost converter (P_{TOTAL}) can be expressed as the sum of the losses in the device (P_{IC}), MOSFET power losses (P_Q), diode power losses (P_D), inductor power losses (P_L), and the loss in the sense resistor (P_{RS}).

$$P_{TOTAL} = P_{IC} + P_Q + P_D + P_L + P_{RS} \quad (19)$$

P_{IC} can be separated into gate driving loss (P_G) and the losses caused by quiescent current (P_{IQ}).

$$P_{IC} = P_G + P_{IQ} \quad (20)$$

Each power loss is approximately calculated as follows:

$$P_G = Q_{G@VCC} \times V_{BIAS} \times f_{SW} \quad (21)$$

$$P_{IQ} = V_{BIAS} \times I_{BIAS} \quad (22)$$

I_{VIN} and I_{VOUT} values in each mode can be found in the supply current section of [Section 7.5](#).

P_Q can be separated into switching loss ($P_{Q(SW)}$) and conduction loss ($P_{Q(COND)}$).

$$P_Q = P_{Q(SW)} + P_{Q(COND)} \quad (23)$$

Each power loss is approximately calculated as follows:

$$P_{Q(SW)} = 0.5 \times (V_{LOAD} + V_F) \times I_{SUPPLY} \times (t_R + t_F) \times f_{SW} \quad (24)$$

t_R and t_F are the rise and fall times of the low-side N-channel MOSFET device. I_{SUPPLY} is the input supply current of the boost converter.

$$P_{Q(COND)} = D \times I_{SUPPLY}^2 \times R_{DS(ON)} \quad (25)$$

$R_{DS(ON)}$ is the on-resistance of the MOSFET and is specified in the MOSFET data sheet. Consider the $R_{DS(ON)}$ increase due to self-heating.

P_D can be separated into diode conduction loss (P_{VF}) and reverse recovery loss (P_{RR}).

$$P_D = P_{VF} + P_{RR} \quad (26)$$

Each power loss is approximately calculated as follows:

$$P_{VF} = (1 - D) \times V_F \times I_{SUPPLY} \quad (27)$$

$$P_{RR} = V_{LOAD} \times Q_{RR} \times f_{SW} \quad (28)$$

Q_{RR} is the reverse recovery charge of the diode and is specified in the diode data sheet. Reverse recovery characteristics of the diode strongly affect efficiency, especially when the output voltage is high.

P_L is the sum of DCR loss (P_{DCR}) and AC core loss (P_{AC}). DCR is the DC resistance of inductor which is mentioned in the inductor data sheet.

$$P_L = P_{DCR} + P_{AC} \quad (29)$$

Each power loss is approximately calculated as follows:

$$P_{DCR} = I_{SUPPLY}^2 \times R_{DCR} \quad (30)$$

$$P_{AC} = K \times \Delta I^\beta \times f_{SW}^\alpha \quad (31)$$

$$\Delta I = \frac{V_{SUPPLY} \times D \times \frac{1}{f_{SW}}}{L_M} \quad (32)$$

ΔI is the peak-to-peak inductor current ripple. K , α , and β are core dependent factors which can be provided by the inductor manufacturer.

P_{RS} is calculated as follows:

$$P_{RS} = D \times I_{SUPPLY}^2 \times R_S \tag{33}$$

Efficiency of the power converter can be estimated as follows:

$$\text{Efficiency} = \frac{V_{LOAD} \times I_{LOAD}}{P_{TOTAL} + V_{LOAD} \times I_{LOAD}} \tag{34}$$

9.3.3 Application Curve

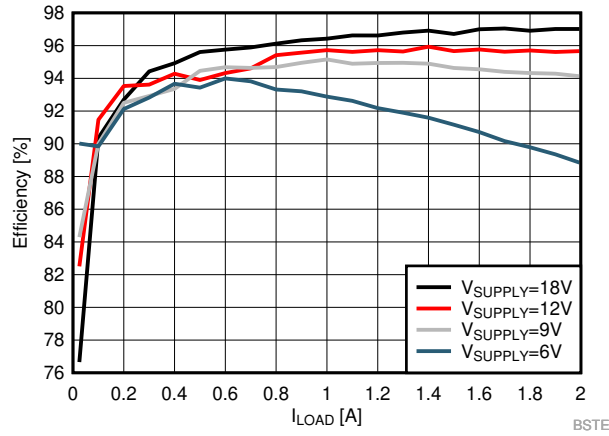

Figure 9-2. Efficiency

9.4 System Examples

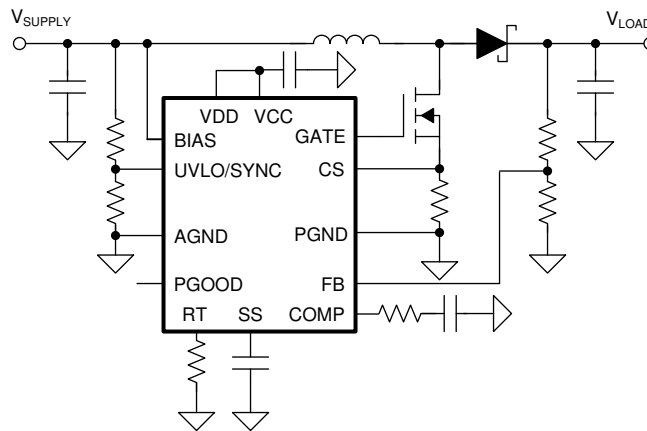

Figure 9-3. Typical Boost Application

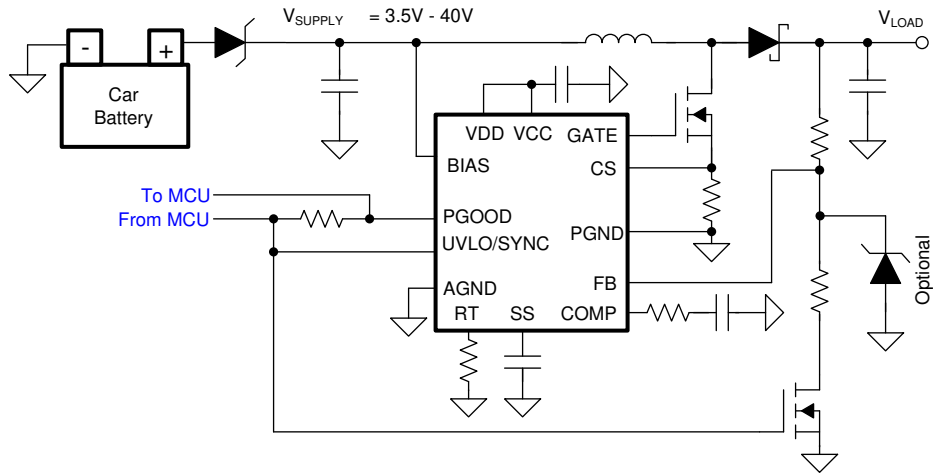

Figure 9-4. Typical Start-Stop Application

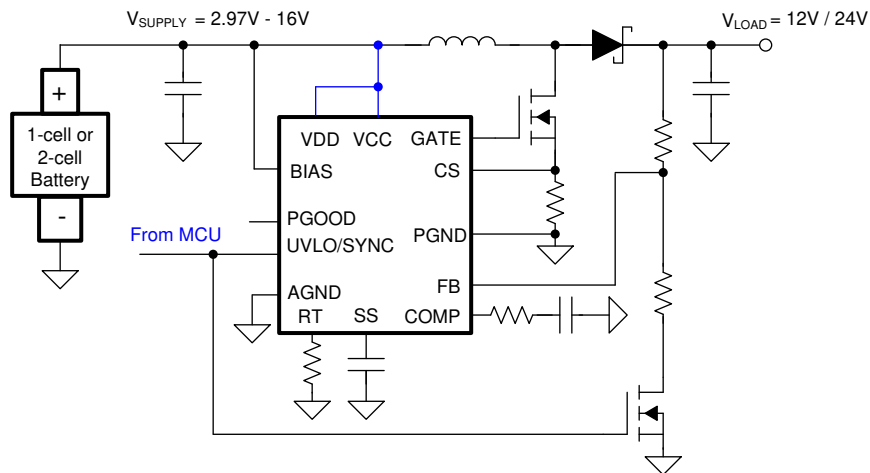

Figure 9-5. Emergency-call / Boost On-Demand / Portable Speaker

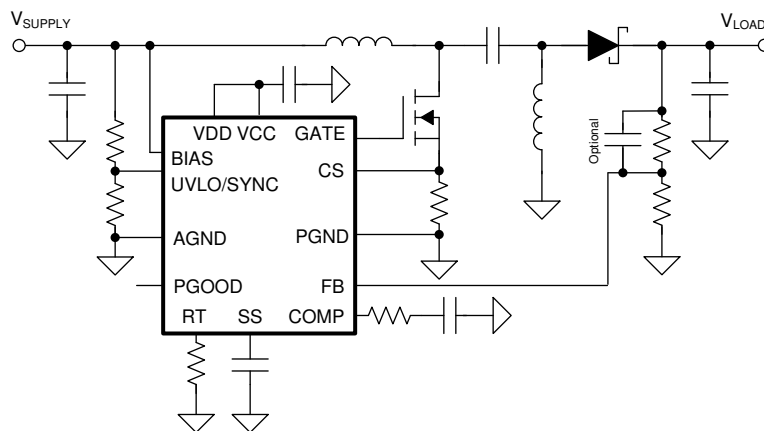

Figure 9-6. Typical SEPIC Application

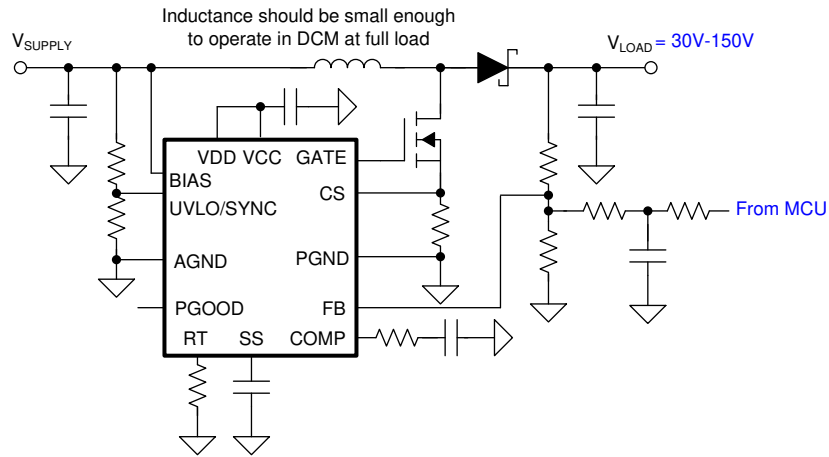

Figure 9-7. LIDAR Bias Supply 1

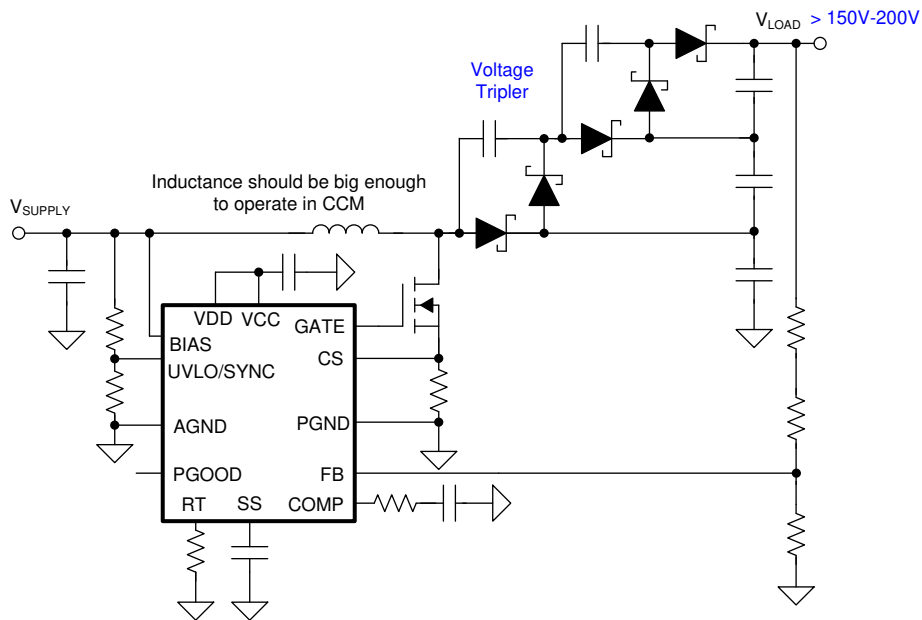

Figure 9-8. LIDAR Bias Supply 2

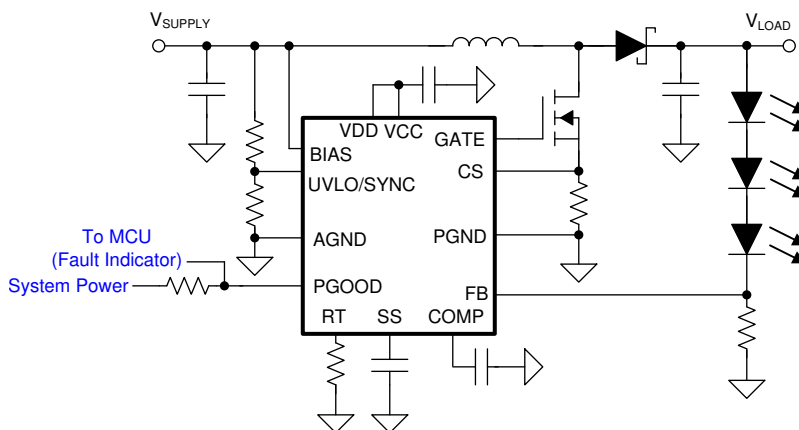

Figure 9-9. Low-Cost LED Driver

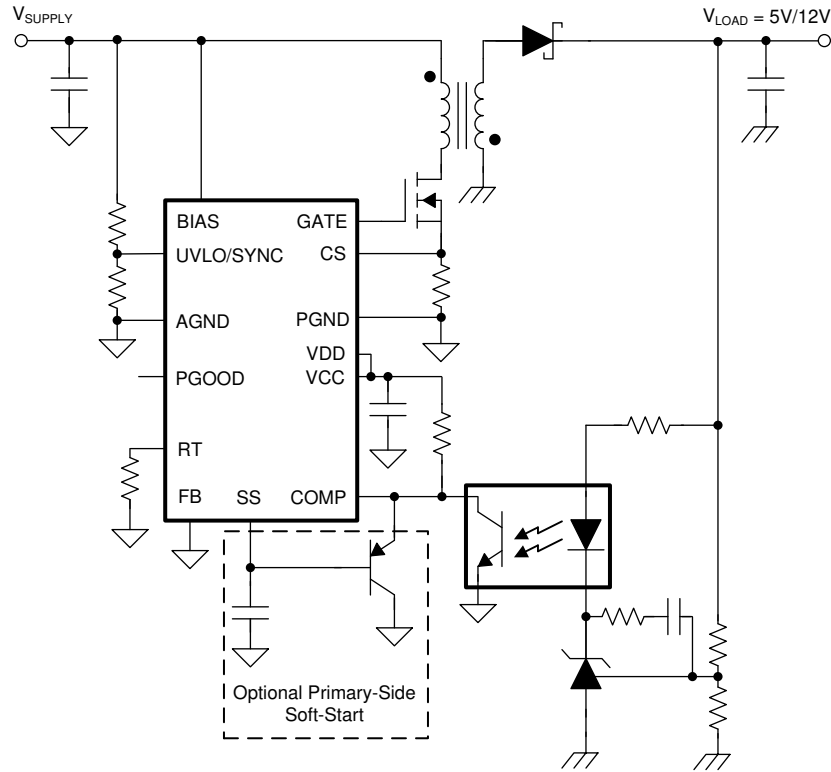

Figure 9-10. Secondary-Side Regulated Isolated Flyback

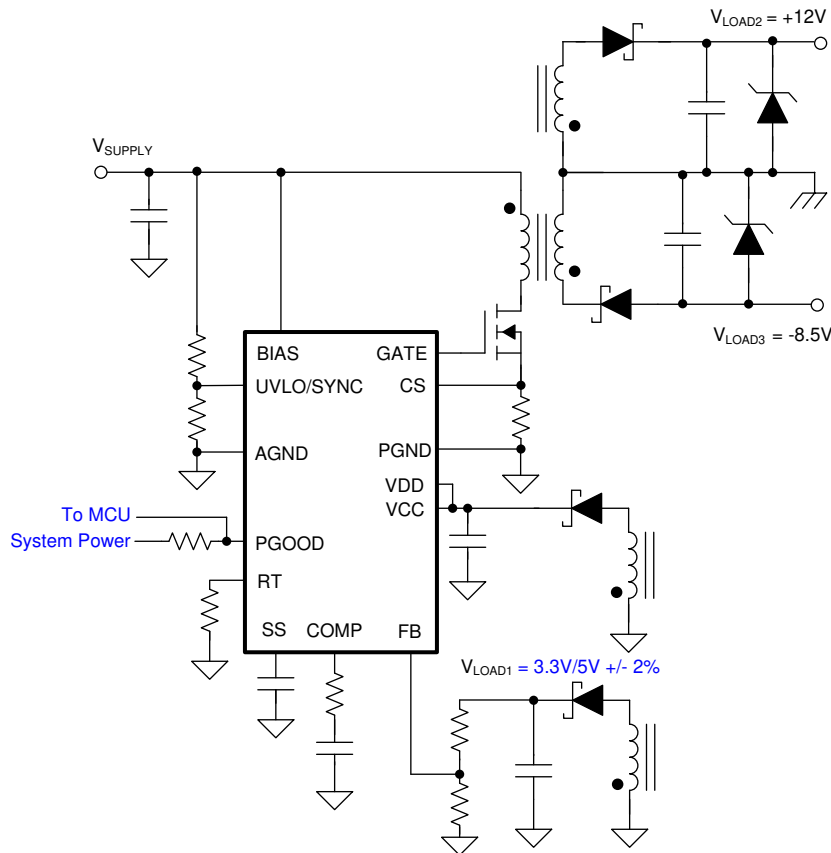

Figure 9-11. Primary-Side Regulated Multiple-Output Isolated Flyback

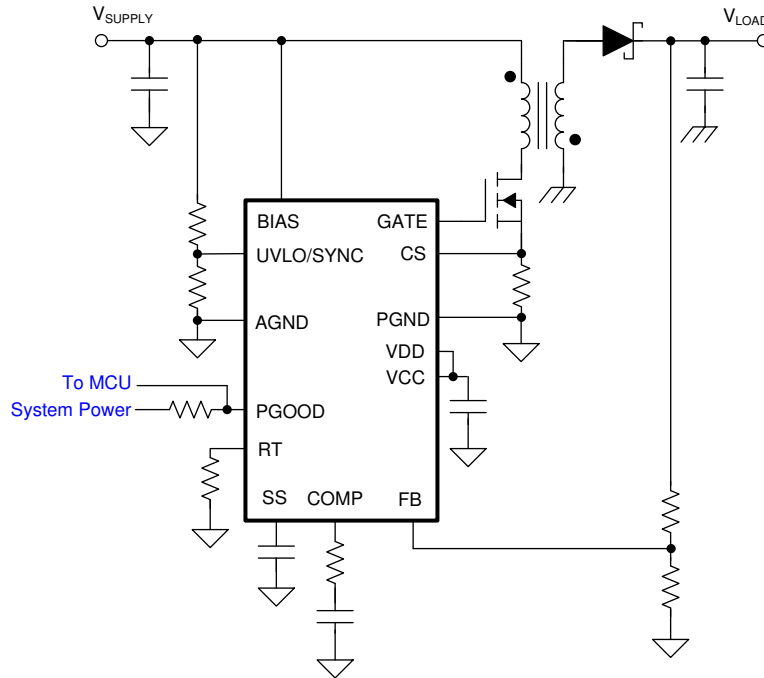

Figure 9-12. Typical Non-Isolated Flyback

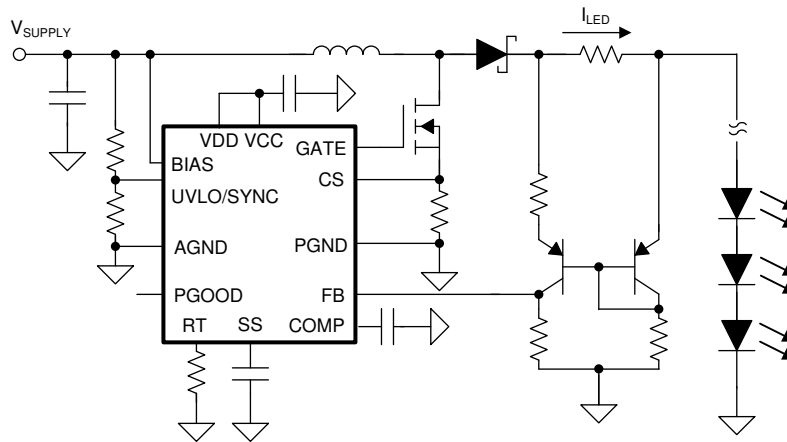

Figure 9-13. LED Driver with High-Side Current Sensing

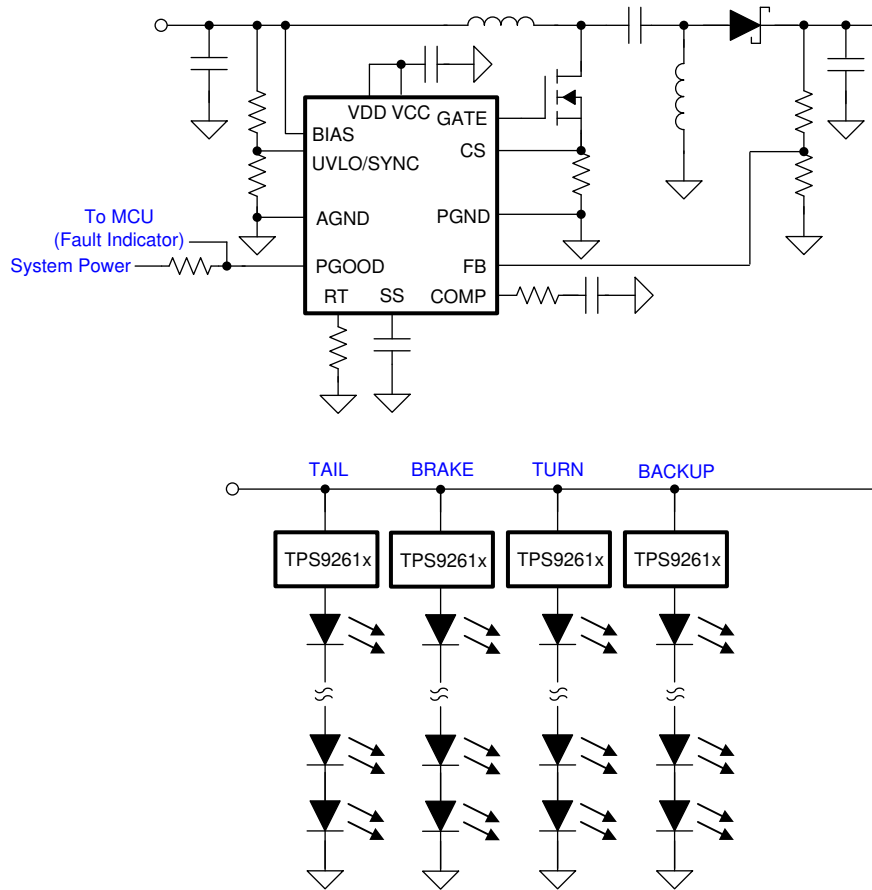

Figure 9-14. Dual-Stage Automotive Rear-Lights LED Driver

10 Power Supply Recommendations

The device is designed to operate from a power supply or a battery whose voltage range is from 1.5 V to 45 V. The input power supply must be able to supply the maximum boost supply voltage and handle the maximum input current at 1.5 V. The impedance of the power supply and battery including cables must be low enough that an input current transient does not cause an excessive drop. Additional input ceramic capacitors may be required at the supply input of the converter.

11 Layout

11.1 Layout Guidelines

The performance of switching converters heavily depends on the quality of the PCB layout. The following guidelines will help users design a PCB with the best power conversion performance, thermal performance, and minimize generation of unwanted EMI.

- Put the Q1, D1, and R_S components on the board first.
- Use a small size ceramic capacitor for C_{OUT} .
- Make the switching loop (C_{OUT} to D1 to Q1 to R_S to C_{OUT}) as small as possible.
- Leave a copper area near the D1 diode for thermal dissipation.
- Put the device near the R_S resistor.
- Put the C_{VCC} capacitor as near the device as possible between the VCC and PGND pins.
- Use a wide and short trace to connect the PGND pin directly to the center of the sense resistor.
- Connect the CS pin to the center of the sense resistor. If necessary, use vias.
- Connect a filter capacitor between CS pin and power ground trace.
- Connect the COMP pin to the compensation components (R_{COMP} and C_{COMP}).
- Connect the C_{COMP} capacitor to the power ground trace.
- Connect the AGND pin directly to the analog ground plane. Connect the AGND pin to the R_{UVLOB} , R_T , C_{SS} , and R_{FBB} components.
- Connect the exposed pad to the AGND pin under the device.
- Connect the GATE pin to the gate of the Q1 FET. If necessary, use vias.
- Make the switching signal loop (GATE to Q1 to R_S to PGND to GATE) as small as possible.
- Add several vias under the exposed pad to help conduct heat away from the device. Connect the vias to a large ground plane on the bottom layer.

11.2 Layout Examples

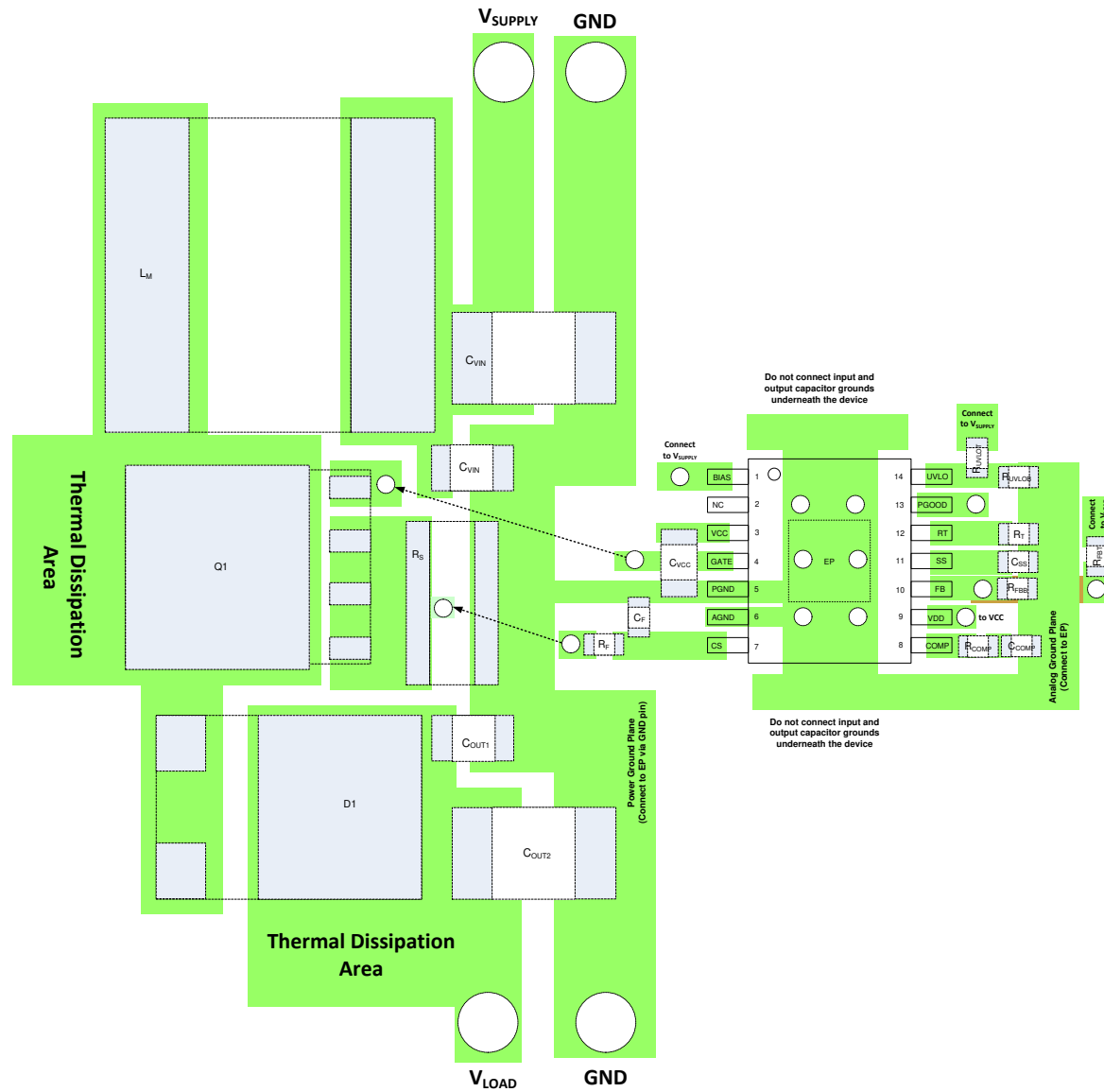

Figure 11-1. PCB Layout Example 1

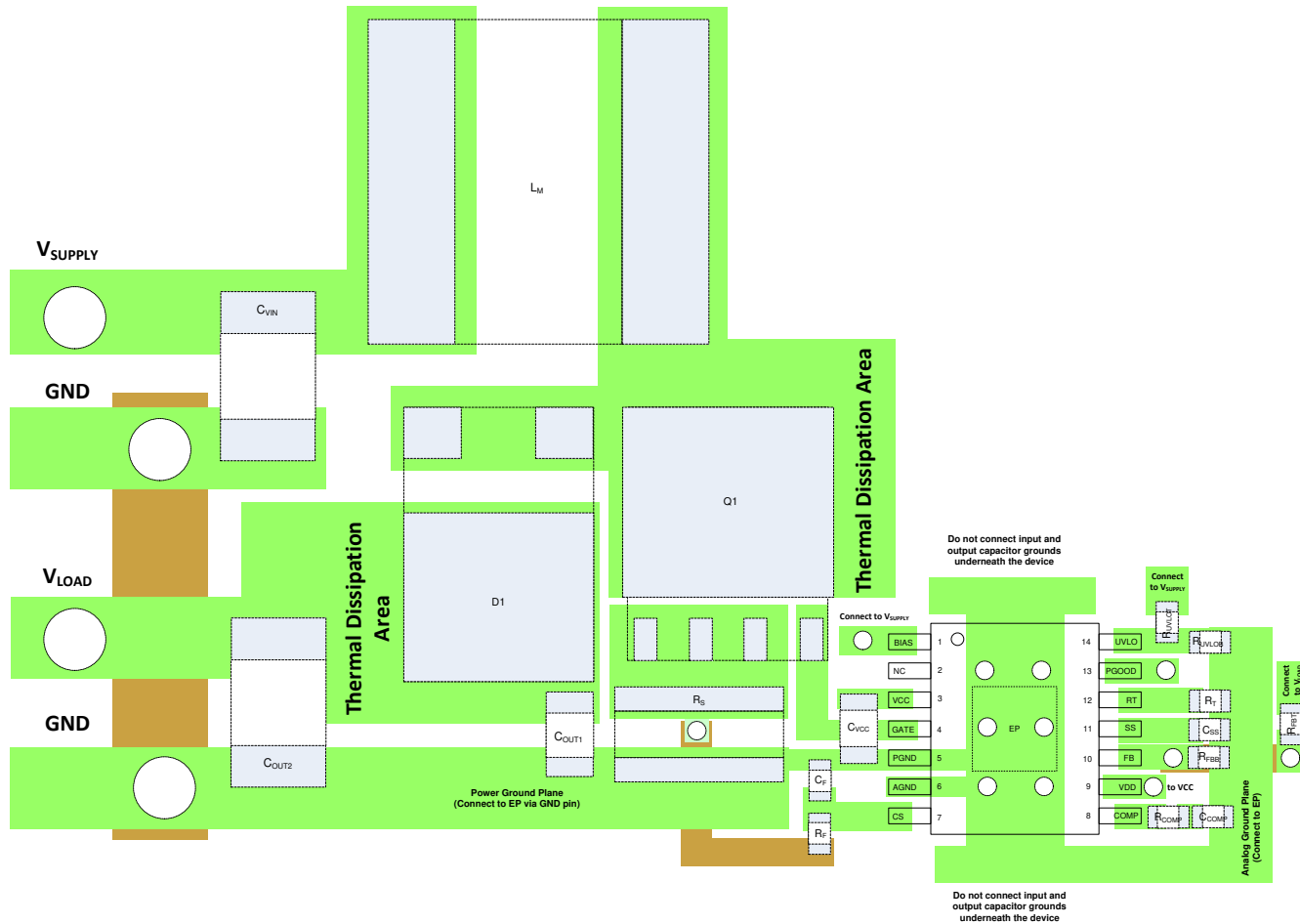

Figure 11-2. PCB Layout Example 2

12 Device and Documentation Support

12.1 Device Support

12.1.1 Third-Party Products Disclaimer

TI'S PUBLICATION OF INFORMATION REGARDING THIRD-PARTY PRODUCTS OR SERVICES DOES NOT CONSTITUTE AN ENDORSEMENT REGARDING THE SUITABILITY OF SUCH PRODUCTS OR SERVICES OR A WARRANTY, REPRESENTATION OR ENDORSEMENT OF SUCH PRODUCTS OR SERVICES, EITHER ALONE OR IN COMBINATION WITH ANY TI PRODUCT OR SERVICE.

12.1.2 Development Support

For development support see the following:

- [LM5155x / LM5156x Boost Quick Start Calculator](#)
- [LM5155x / LM5156x Flyback Quick Start Calculator](#)
- [LM5155x / LM5156x SEPIC Quick Start Calculator](#)
- [How to Design a Boost Converter Using LM5156x](#)
- [How to Design an Isolated Flyback Converter Using LM5156x](#)
- [How to Design a SEPIC Converter Using LM5156x](#)

12.1.2.1 Custom Design With WEBENCH® Tools

[Click here](#) to create a custom design using the device with the WEBENCH® Power Designer.

1. Start by entering the input voltage (V_{IN}), output voltage (V_{OUT}), and output current (I_{OUT}) requirements.
2. Optimize the design for key parameters such as efficiency, footprint, and cost using the optimizer dial.
3. Compare the generated design with other possible solutions from Texas Instruments.

The WEBENCH Power Designer provides a customized schematic along with a list of materials with real-time pricing and component availability.

In most cases, these actions are available:

- Run electrical simulations to see important waveforms and circuit performance
- Run thermal simulations to understand board thermal performance
- Export customized schematic and layout into popular CAD formats
- Print PDF reports for the design, and share the design with colleagues

Get more information about WEBENCH tools at www.ti.com/WEBENCH.

12.2 Receiving Notification of Documentation Updates

To receive notification of documentation updates, navigate to the device product folder on ti.com. Click on *Subscribe to updates* to register and receive a weekly digest of any product information that has changed. For change details, review the revision history included in any revised document.

12.3 Support Resources

[TI E2E™ support forums](#) are an engineer's go-to source for fast, verified answers and design help — straight from the experts. Search existing answers or ask your own question to get the quick design help you need.

Linked content is provided "AS IS" by the respective contributors. They do not constitute TI specifications and do not necessarily reflect TI's views; see TI's [Terms of Use](#).

12.4 Trademarks

TI E2E™ is a trademark of Texas Instruments.

WEBENCH® is a registered trademark of Texas Instruments.

All other trademarks are the property of their respective owners.

12.5 Electrostatic Discharge Caution



This integrated circuit can be damaged by ESD. Texas Instruments recommends that all integrated circuits be handled with appropriate precautions. Failure to observe proper handling and installation procedures can cause damage.

ESD damage can range from subtle performance degradation to complete device failure. Precision integrated circuits may be more susceptible to damage because very small parametric changes could cause the device not to meet its published specifications.

12.6 Glossary

TI Glossary

This glossary lists and explains terms, acronyms, and definitions.

13 Mechanical, Packaging, and Orderable Information

The following pages include mechanical, packaging, and orderable information. This information is the most current data available for the designated devices. This data is subject to change without notice and revision of this document. For browser-based versions of this data sheet, refer to the left-hand navigation.

PACKAGING INFORMATION

Orderable part number	Status (1)	Material type (2)	Package Pins	Package qty Carrier	RoHS (3)	Lead finish/ Ball material (4)	MSL rating/ Peak reflow (5)	Op temp (°C)	Part marking (6)
LM34966QPWPRQ1	Active	Production	HTSSOP (PWP) 14	2000 LARGE T&R	Yes	NIPDAU	Level-3-260C-168 HR	-40 to 150	34966Q
LM34966QPWPRQ1.A	Active	Production	HTSSOP (PWP) 14	2000 LARGE T&R	Yes	NIPDAU	Level-3-260C-168 HR	-40 to 150	34966Q

(1) **Status:** For more details on status, see our [product life cycle](#).

(2) **Material type:** When designated, preproduction parts are prototypes/experimental devices, and are not yet approved or released for full production. Testing and final process, including without limitation quality assurance, reliability performance testing, and/or process qualification, may not yet be complete, and this item is subject to further changes or possible discontinuation. If available for ordering, purchases will be subject to an additional waiver at checkout, and are intended for early internal evaluation purposes only. These items are sold without warranties of any kind.

(3) **RoHS values:** Yes, No, RoHS Exempt. See the [TI RoHS Statement](#) for additional information and value definition.

(4) **Lead finish/Ball material:** Parts may have multiple material finish options. Finish options are separated by a vertical ruled line. Lead finish/Ball material values may wrap to two lines if the finish value exceeds the maximum column width.

(5) **MSL rating/Peak reflow:** The moisture sensitivity level ratings and peak solder (reflow) temperatures. In the event that a part has multiple moisture sensitivity ratings, only the lowest level per JEDEC standards is shown. Refer to the shipping label for the actual reflow temperature that will be used to mount the part to the printed circuit board.

(6) **Part marking:** There may be an additional marking, which relates to the logo, the lot trace code information, or the environmental category of the part.

Multiple part markings will be inside parentheses. Only one part marking contained in parentheses and separated by a "~" will appear on a part. If a line is indented then it is a continuation of the previous line and the two combined represent the entire part marking for that device.

Important Information and Disclaimer:The information provided on this page represents TI's knowledge and belief as of the date that it is provided. TI bases its knowledge and belief on information provided by third parties, and makes no representation or warranty as to the accuracy of such information. Efforts are underway to better integrate information from third parties. TI has taken and continues to take reasonable steps to provide representative and accurate information but may not have conducted destructive testing or chemical analysis on incoming materials and chemicals. TI and TI suppliers consider certain information to be proprietary, and thus CAS numbers and other limited information may not be available for release.

In no event shall TI's liability arising out of such information exceed the total purchase price of the TI part(s) at issue in this document sold by TI to Customer on an annual basis.

TAPE AND REEL INFORMATION

QUADRANT ASSIGNMENTS FOR PIN 1 ORIENTATION IN TAPE



*All dimensions are nominal

Device	Package Type	Package Drawing	Pins	SPQ	Reel Diameter (mm)	Reel Width W1 (mm)	A0 (mm)	B0 (mm)	K0 (mm)	P1 (mm)	W (mm)	Pin1 Quadrant
LM34966QPWRQ1	HTSSOP	PWP	14	2000	330.0	12.4	6.9	5.6	1.6	8.0	12.0	Q1

TAPE AND REEL BOX DIMENSIONS

*All dimensions are nominal

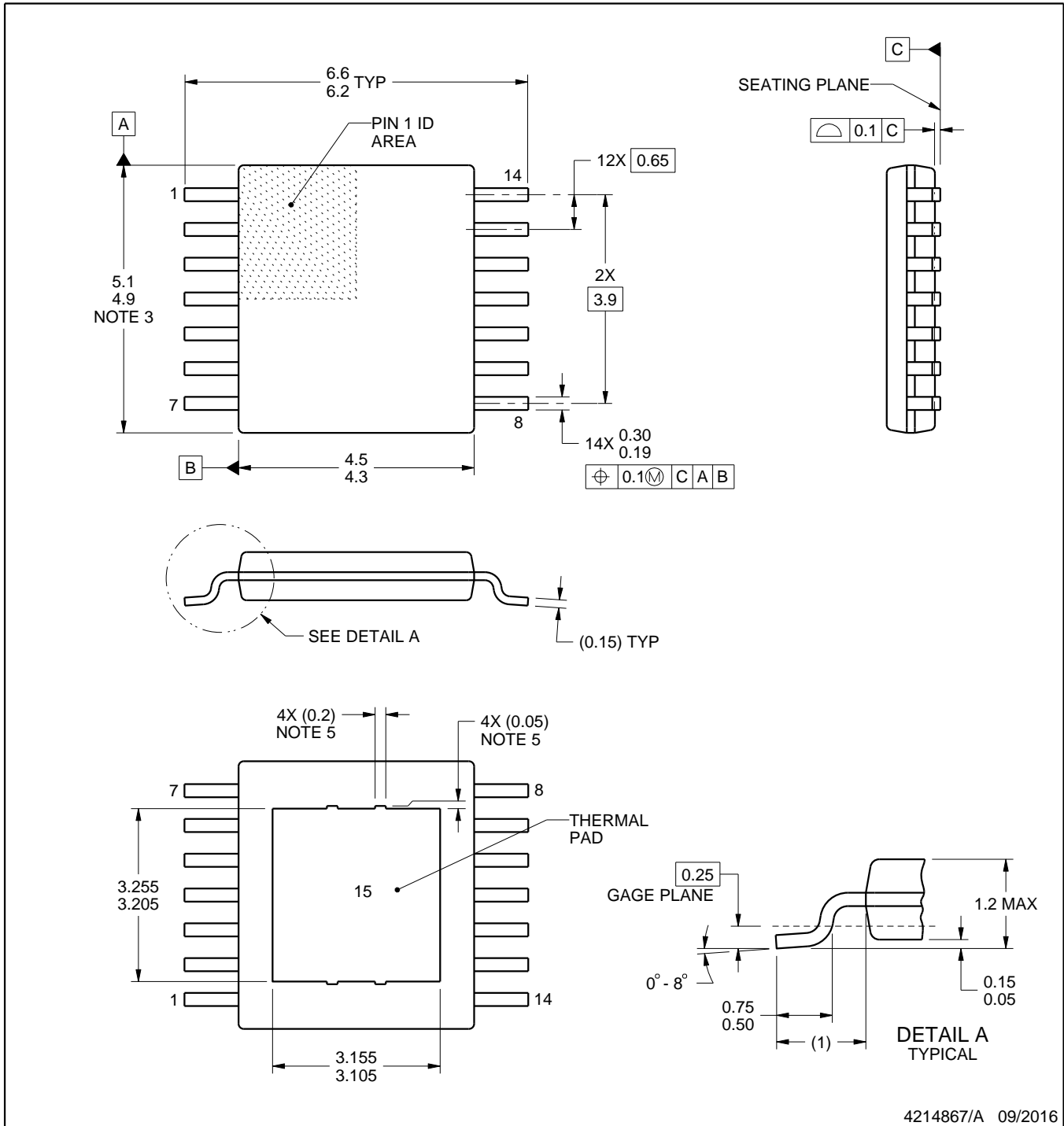
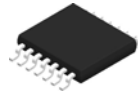
Device	Package Type	Package Drawing	Pins	SPQ	Length (mm)	Width (mm)	Height (mm)
LM34966QPWPRQ1	HTSSOP	PWP	14	2000	350.0	350.0	43.0



4214867/A 09/2016

NOTES:

PowerPAD is a trademark of Texas Instruments.

1. All linear dimensions are in millimeters. Any dimensions in parenthesis are for reference only. Dimensioning and tolerancing per ASME Y14.5M.
2. This drawing is subject to change without notice.
3. This dimension does not include mold flash, protrusions, or gate burrs. Mold flash, protrusions, or gate burrs shall not exceed 0.15 mm per side.
4. Reference JEDEC registration MO-153.
5. Features may differ and may not be present.

EXAMPLE BOARD LAYOUT

PWP0014A

PowerPAD™ TSSOP - 1.2 mm max height

PLASTIC SMALL OUTLINE

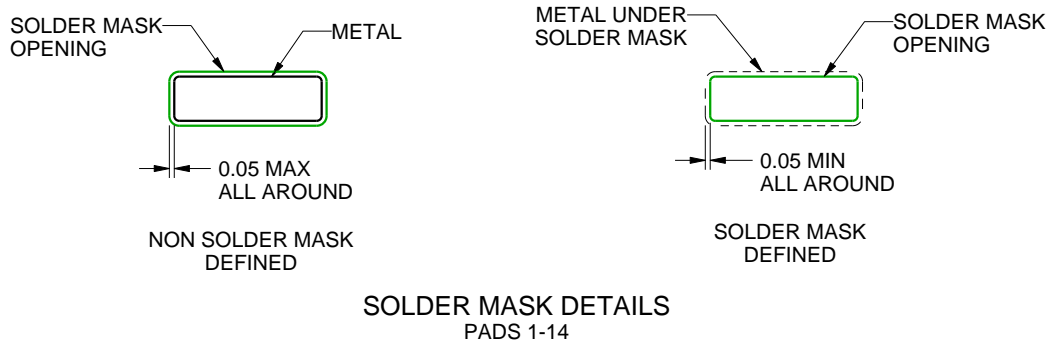
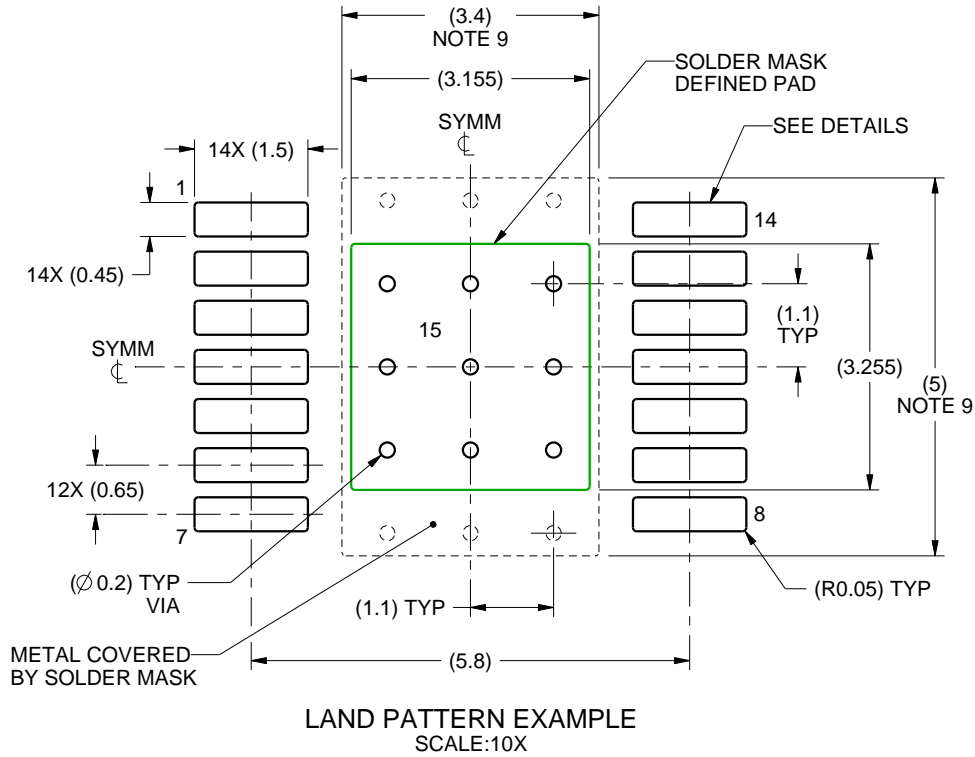

4214867/A 09/2016

NOTES: (continued)

6. Publication IPC-7351 may have alternate designs.
7. Solder mask tolerances between and around signal pads can vary based on board fabrication site.
8. This package is designed to be soldered to a thermal pad on the board. For more information, see Texas Instruments literature numbers SLMA002 (www.ti.com/lit/slma002) and SLMA004 (www.ti.com/lit/slma004).
9. Size of metal pad may vary due to creepage requirement.

EXAMPLE STENCIL DESIGN

PWP0014A

PowerPAD™ TSSOP - 1.2 mm max height

PLASTIC SMALL OUTLINE

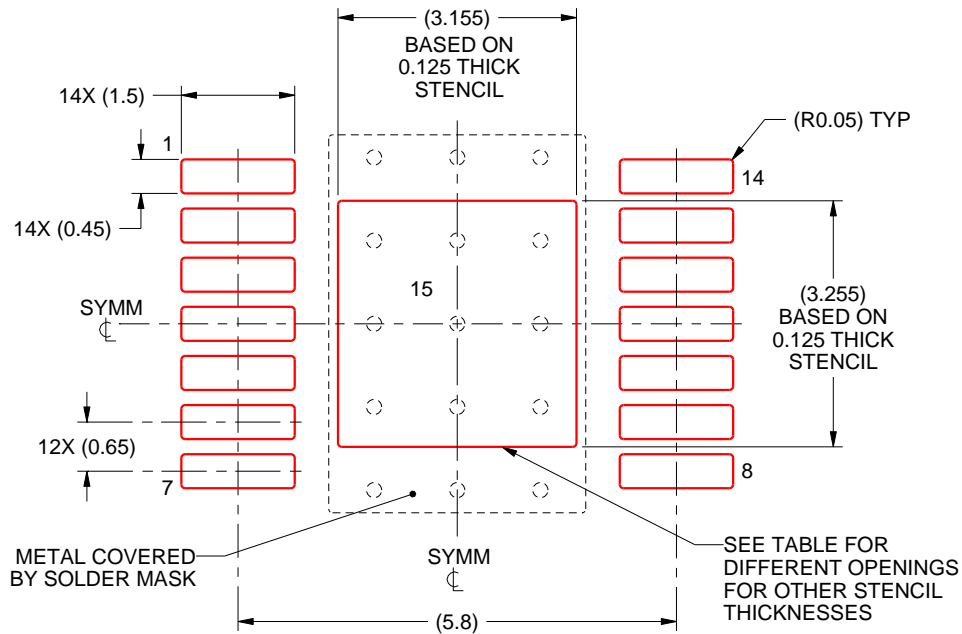

SOLDER PASTE EXAMPLE
 EXPOSED PAD
 100% PRINTED SOLDER COVERAGE BY AREA
 SCALE:10X

STENCIL THICKNESS	SOLDER STENCIL OPENING
0.1	3.53 X 3.64
0.125	3.155 X 3.255 (SHOWN)
0.15	2.88 X 2.97
0.175	2.67 X 2.75

4214867/A 09/2016

NOTES: (continued)

10. Laser cutting apertures with trapezoidal walls and rounded corners may offer better paste release. IPC-7525 may have alternate design recommendations.
11. Board assembly site may have different recommendations for stencil design.

IMPORTANT NOTICE AND DISCLAIMER

TI PROVIDES TECHNICAL AND RELIABILITY DATA (INCLUDING DATA SHEETS), DESIGN RESOURCES (INCLUDING REFERENCE DESIGNS), APPLICATION OR OTHER DESIGN ADVICE, WEB TOOLS, SAFETY INFORMATION, AND OTHER RESOURCES "AS IS" AND WITH ALL FAULTS, AND DISCLAIMS ALL WARRANTIES, EXPRESS AND IMPLIED, INCLUDING WITHOUT LIMITATION ANY IMPLIED WARRANTIES OF MERCHANTABILITY, FITNESS FOR A PARTICULAR PURPOSE OR NON-INFRINGEMENT OF THIRD PARTY INTELLECTUAL PROPERTY RIGHTS.

These resources are intended for skilled developers designing with TI products. You are solely responsible for (1) selecting the appropriate TI products for your application, (2) designing, validating and testing your application, and (3) ensuring your application meets applicable standards, and any other safety, security, regulatory or other requirements.

These resources are subject to change without notice. TI grants you permission to use these resources only for development of an application that uses the TI products described in the resource. Other reproduction and display of these resources is prohibited. No license is granted to any other TI intellectual property right or to any third party intellectual property right. TI disclaims responsibility for, and you will fully indemnify TI and its representatives against, any claims, damages, costs, losses, and liabilities arising out of your use of these resources.

TI's products are provided subject to [TI's Terms of Sale](#) or other applicable terms available either on [ti.com](https://www.ti.com) or provided in conjunction with such TI products. TI's provision of these resources does not expand or otherwise alter TI's applicable warranties or warranty disclaimers for TI products.

TI objects to and rejects any additional or different terms you may have proposed.

Mailing Address: Texas Instruments, Post Office Box 655303, Dallas, Texas 75265
Copyright © 2025, Texas Instruments Incorporated