

INA791x-Q1 AEC-Q100, –4V to 110V, Bidirectional, Ultra-Precise, High Bandwidth Current Sense Amplifier With 75A EZShunt™ Technology

1 Features

- AEC-Q100 qualified for automotive applications:
 - Temperature grade 1: –40°C to +125°C, T_A
- [Functional Safety-Capable](#)
 - [Documentation available to aid functional safety system design](#)
- Precision design with integrated shunt resistor
 - ±75A continuous current at 25°C
 - ±50A continuous current at +125°C
 - Shunt resistor: 400μΩ
 - Shunt inductance: 2nH
- Wide common-mode voltage range: –4V to +110V
- High small signal bandwidth : 1MHz
- Excellent CMRR
 - 160dB DC CMRR
 - 114dB AC CMRR at 50kHz
- High measurement accuracy
 - System Gain error (maximum)
 - Version A: ±0.35%, ±35ppm/°C drift
 - Version B: ±1%, ±100ppm/°C drift
 - Offset current (maximum)
 - Version A: ±40mA, ±70mA over temperature
 - Version B: ±210mA, ±250mA over temperature
- Adjustable gain with external resistor divider network: 20mV/A to 400mV/A
- Open-drain temperature alert at T_J of 160°C

2 Applications

- [DC/DC converter](#)
- [Battery management systems \(BMS\)](#)
- [Fuel cell control unit](#)
- [Smart junction box](#)

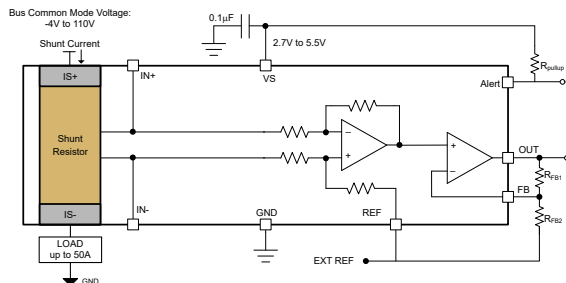

Typical Application

3 Description

The INA791x-Q1 is a voltage output, current sense amplifier with an integrated shunt resistor of 400μΩ. The INA791x-Q1 is designed to monitor bidirectional current over a common-mode range of –4V to 110V, independent of the supply voltage. Adjustable gain option assists in optimizing the system dynamic range. The integration of the Kelvin connected shunt resistor with a zero-drift chopped amplifier provides calibration equivalent measurement accuracy, ultra-low temperature drift performance of ±35ppm/°C, and an optimized layout for the sensing resistor.

This device operates from a single 2.7V to 5.5V power supply, drawing a maximum of 4.25mA of supply current. All versions are specified over the extended operating temperature range (–40°C to +125°C), and are available in a 15-pin wettable flank VQFN package.

Package Information

PART NUMBER	PACKAGE ⁽¹⁾	PACKAGE SIZE ⁽²⁾
INA791A-Q1, INA791B-Q1	DEK (VQFN, 15)	6mm × 6mm

- (1) For all available packages, see the orderable addendum at the end of the data sheet.
- (2) The package size (length × width) is a nominal value and includes pins, where applicable.

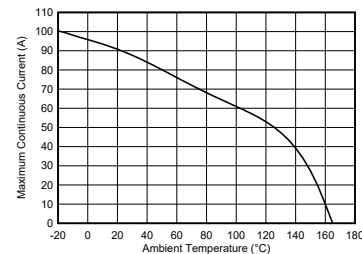

Maximum Continuous Current vs Ambient Temperature



Table of Contents

1 Features	1	7 Application and Implementation	20
2 Applications	1	7.1 Application Information.....	20
3 Description	1	7.2 Typical Applications.....	25
4 Pin Configuration and Functions	3	7.3 Power Supply Recommendations.....	27
5 Specifications	4	7.4 Layout.....	27
5.1 Absolute Maximum Ratings.....	4	8 Device and Documentation Support	28
5.2 ESD Ratings.....	4	8.1 Documentation Support.....	28
5.3 Recommended Operating Conditions.....	4	8.2 Receiving Notification of Documentation Updates.....	28
5.4 Thermal Information.....	4	8.3 Support Resources.....	28
5.5 Electrical Characteristics.....	5	8.4 Trademarks.....	29
5.6 Typical Characteristics.....	7	8.5 Electrostatic Discharge Caution.....	29
6 Detailed Description	13	8.6 Glossary.....	29
6.1 Overview.....	13	9 Revision History	29
6.2 Functional Block Diagram.....	13	10 Mechanical, Packaging, and Orderable Information	29
6.3 Feature Description.....	13		
6.4 Device Functional Modes.....	15		

4 Pin Configuration and Functions

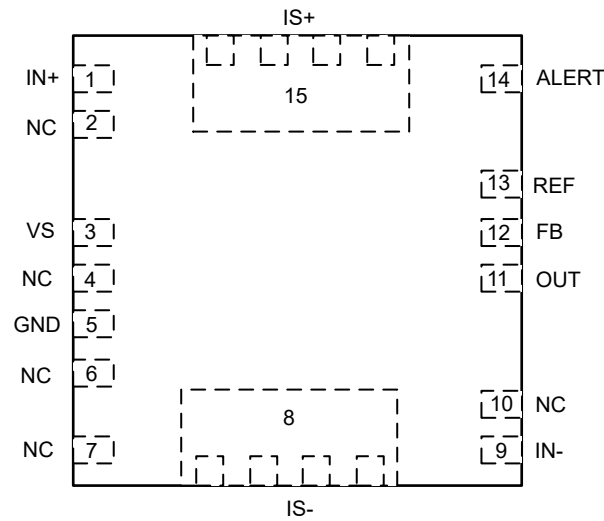

Figure 4-1. INA791x-Q1 Wettable DEK Package 15-Pin VQFN Top View

Table 4-1. Pin Functions

PIN		TYPE	DESCRIPTION
NAME	NO.		
ALERT	14	Digital Out	Open-drain temperature alert
FB	12	Analog Input	Gain adjustment feedback; connect to resistor divider to adjust device gain
GND	5	Analog	Ground
IN-	9	Analog Input	Kelvin connection to internal shunt on load side and negative amplifier input
IN+	1	Analog Input	Kelvin connection to internal shunt on supply side and positive amplifier input
IS-	8	Analog Input	Connect to load
IS+	15	Analog Input	Connect to supply
NC	2	–	Connect to IN+ (Pin 1)
NC	4, 6, 7	–	Connect to ground or leave unconnected
NC	10	–	Connect to IN- (Pin 9)
OUT	11	Analog Output	Output voltage
REF	13	Analog Input	Reference voltage, 0V to VS
VS	3	Analog	Power supply, 2.7V to 5.5V

5 Specifications

5.1 Absolute Maximum Ratings

over operating free-air temperature range (unless otherwise noted)⁽¹⁾

		MIN	MAX	UNIT
Supply voltage (V_S)			6	V
Analog Inputs, V_{IN+} , V_{IN-} ⁽²⁾	Differential (V_{IN+}) - (V_{IN-})	-12	12	V
	Common-mode	GND – 20	120	V
Analog input (REF)	Analog input (REF)	GND – 0.3	$V_S + 0.3$	V
Analog input (FB)	Analog input (FB)	GND – 0.3	$V_S + 0.3$	V
Analog output (OUT)	Analog output (OUT)	GND – 0.3	$V_S + 0.3$	V
Digital output (ALERT)	Temperature Alert Output	GND – 0.3	$V_S + 0.3$	V
T_A	Operating Temperature	-55	150	°C
T_J	Junction temperature		165	°C
T_{stg}	Storage temperature	-65	165	°C

- (1) Operation outside the Absolute Maximum Ratings may cause permanent device damage. Absolute Maximum Ratings do not imply functional operation of the device at these or any other conditions beyond those listed under Recommended Operating Conditions. If used outside the Recommended Operating Conditions but within the Absolute Maximum Ratings, the device may not be fully functional, and this may affect device reliability, functionality, performance, and shorten the device lifetime.
- (2) V_{IN+} and V_{IN-} are the voltages at the IN+ and IN– pins, respectively.

5.2 ESD Ratings

			VALUE	UNIT
$V_{(ESD)}$	Electrostatic discharge	Human body model (HBM), per AEC Q100-002 ⁽¹⁾	±2000	V
		Charged device model (CDM), per AEC Q100-011	±1000	

- (1) AEC Q100-002 indicates that HBM stressing shall be in accordance with the ANSI/ESDA/JEDEC JS-001 specification.

5.3 Recommended Operating Conditions

over operating free-air temperature range (unless otherwise noted)

		MIN	NOM	MAX	UNIT
V_{CM}	Common-mode input range	-4		110	V
V_S	Operating supply range	2.7		5.5	V
I_{SENSE}	Continuous Current	-50		50	A
V_{REF}	Reference voltage range	0		V_S	V
V_{FB}	Feed-back voltage range	0		V_S	V
T_A	Ambient temperature	-40		125	°C

5.4 Thermal Information

THERMAL METRIC ⁽¹⁾		INA791x-Q1	UNIT
		DEK (VQFN)	
		15 PINS	
$R_{\theta JA}$	Junction-to-ambient thermal resistance	28.7	°C/W
$R_{\theta JC(top)}$	Junction-to-case (top) thermal resistance	8.3	°C/W
$R_{\theta JB}$	Junction-to-board thermal resistance ⁽²⁾	30.8	°C/W
Ψ_{JT}	Junction-to-top characterization parameter ⁽²⁾	1.1	°C/W

THERMAL METRIC ⁽¹⁾		INA791x-Q1		
		DEK (VQFN)		
		15 PINS		
Ψ_{JB}	Junction-to-board characterization parameter ⁽²⁾	8.4		°C/W

- (1) For more information about traditional and new thermal metrics, see the [Semiconductor and IC Package Thermal Metrics](#) application note.
- (2) Thermal metrics are relative to the internal die and are conservative relative to the heating that occur from the package leadframe shunt. For more details on heating, see the Safe Operating Area section.

5.5 Electrical Characteristics

at $T_A = 25^\circ\text{C}$, $V_S = 5\text{V}$, $I_{\text{SENSE}} = I_{S+} = 0\text{A}$, $V_{\text{CM}} = V_{\text{IN-}} = 48\text{V}$, $V_{\text{FB}} = V_{\text{OUT}}$ (Adjustable Gain = 1), and $V_{\text{REF}} = V_S / 2$ (unless otherwise noted)

PARAMETER		TEST CONDITIONS	MIN	TYP	MAX	UNIT
INPUT						
V_{CM}	Common-mode input range	$V_{\text{IN+}} = -4\text{V to } 110\text{V}$, $I_{\text{SENSE}} = 0\text{A}$, $T_A = -40^\circ\text{C to } +125^\circ\text{C}$	-4		110	V
CMRR	Common-mode rejection ratio	$V_{\text{IN+}} = -4\text{V to } 110\text{V}$, $I_{\text{SENSE}} = 0\text{A}$, $T_A = -40^\circ\text{C to } +125^\circ\text{C}$, INA791A-Q1		± 25	± 79	$\mu\text{A/V}$
		$V_{\text{IN+}} = -4\text{V to } 110\text{V}$, $I_{\text{SENSE}} = 0\text{A}$, $T_A = -40^\circ\text{C to } +125^\circ\text{C}$, INA791B-Q1		± 790	± 1250	
CMRR	Common-mode rejection ratio	$f = 50\text{kHz}$		± 56		mA/V
I_{os}	Input referred offset current error	$I_{\text{SENSE}} = 0\text{A}$, INA791A-Q1		± 5	± 40	mA
		$I_{\text{SENSE}} = 0\text{A}$, INA791A-Q1, $T_A = -40^\circ\text{C to } +125^\circ\text{C}$,		± 20	± 70	
		$I_{\text{SENSE}} = 0\text{A}$, INA791B-Q1		± 62.5	± 210	
		$I_{\text{SENSE}} = 0\text{A}$, INA791B-Q1, $T_A = -40^\circ\text{C to } +125^\circ\text{C}$,			± 250	
PSRR	Power supply rejection ratio	$V_S = 2.7\text{V to } 5.5\text{V}$, $V_{\text{REF}} = 1\text{V}$, $I_{\text{SENSE}} = 0\text{A}$, INA791A-Q1		± 1	± 5.5	mA/V
		$V_S = 2.7\text{V to } 5.5\text{V}$, $V_{\text{REF}} = 1\text{V}$, $I_{\text{SENSE}} = 0\text{A}$, INA791B-Q1		± 2.5	± 25	
I_B	Total input bias current	$I_{B+} + I_{B-}$, $I_{\text{SENSE}} = 0\text{A}$	45	66	90	μA
I_{FB}	Feed-back current	$I_{\text{SENSE}} = 0\text{A}$		± 2		nA
		$I_{\text{SENSE}} = 0\text{A}$, $T_A = -40^\circ\text{C to } +125^\circ\text{C}$			± 6	
INTEGRATED SHUNT RESISTOR						
R_{SHUNT}	Internal Kelvin shunt resistance	IN+ to IN-, $T_A = 25^\circ\text{C}$		400		$\mu\Omega$
	Pin to pin package resistance	IS+ to IS-, $T_A = 25^\circ\text{C}$	425	560	650	$\mu\Omega$
	Pin to pin package inductance	IS+ to IS-, $T_A = 25^\circ\text{C}$		2		nH
I_{SENSE}	Maximum Continuous Current	$T_A = -40^\circ\text{C to } +125^\circ\text{C}$			± 50	A
	Short time overload change	$I_{\text{SENSE}} = 120\text{A}$ for 5 seconds		± 0.05		%
	Change due to temperature cycle	$-65^\circ\text{C to } 150^\circ\text{C}$, 500 cycles		± 0.1		%
	Shunt resistance change to solder heat	260°C solder, 10 seconds		± 0.1		%
	High temperature exposure change	1000 hours, $T_A = 150^\circ\text{C}$		± 0.015		%
OUTPUT						
G	Gain	INA791A-Q1, INA791B-Q1		20		mV/A

INA791A-Q1, INA791B-Q1

SBOSAE4 – JANUARY 2026

 at $T_A = 25^\circ\text{C}$, $V_S = 5\text{V}$, $I_{\text{SENSE}} = I_{\text{S}+} = 0\text{A}$, $V_{\text{CM}} = V_{\text{IN-}} = 48\text{V}$, $V_{\text{FB}} = V_{\text{OUT}}$ (Adjustable Gain = 1), and $V_{\text{REF}} = V_S / 2$ (unless otherwise noted)

PARAMETER		TEST CONDITIONS	MIN	TYP	MAX	UNIT
G	System Gain Error (shunt + amplifier)	$\text{GND} + 50\text{mV} \leq V_{\text{OUT}} \leq V_S - 200\text{mV}$, $T_A = 25^\circ\text{C}$, $I_{\text{SENSE}} = \pm 50\text{A}$, INA791A-Q1		± 0.32	± 0.725	%
		$\text{GND} + 50\text{mV} \leq V_{\text{OUT}} \leq V_S - 200\text{mV}$, $T_A = 25^\circ\text{C}$, $I_{\text{SENSE}} = \pm 5\text{A}$, INA791A-Q1		± 0.05	± 0.35	
		⁽¹⁾ $\text{GND} + 50\text{mV} \leq V_{\text{OUT}} \leq V_S - 200\text{mV}$, $T_A = 25^\circ\text{C}$, $I_{\text{SENSE}} = \pm 50\text{A}$, INA791B-Q1		± 0.3	± 1	
		$\text{GND} + 50\text{mV} \leq V_{\text{OUT}} \leq V_S - 200\text{mV}$, $T_A = 25^\circ\text{C}$, $I_{\text{SENSE}} = \pm 5\text{A}$, INA791B-Q1		± 0.1	± 0.625	
G	System Gain Error Drift (shunt + amplifier)	$T_A = +25^\circ\text{C}$ to $+125^\circ\text{C}$, INA791A-Q1		± 4	± 35	ppm/ $^\circ\text{C}$
		$T_A = -40^\circ\text{C}$ to $+25^\circ\text{C}$, INA791A-Q1		± 10	± 60	
		$T_A = -40^\circ\text{C}$ to $+125^\circ\text{C}$, INA791B-Q1		± 10	± 100	
	Power Coefficient Gain Non-Linearity Error	⁽²⁾ $\text{GND} + 10\text{mV} \leq V_{\text{OUT}} \leq V_S - 200\text{mV}$		$+1.5$		ppm/ A^2
RVRR	Reference voltage rejection ratio (input - referred)	$V_{\text{REF}} = 0.5\text{V}$ to 4.5V		± 2.5	± 12.5	mA/V
	Maximum Capacitive Load	No sustained oscillation		0.5		nF
VOLTAGE OUTPUT						
	Swing to V_S Power Supply Rail	$R_L = 10\text{k}\Omega$ to GND, $V_{\text{REF}} = V_S$, Adjustable Gain = 4, $T_A = -40^\circ\text{C}$ to $+125^\circ\text{C}$		$V_S - 0.05$	$V_S - 0.1$	V
	Swing to Ground	$R_L = 10\text{k}\Omega$ to GND, $V_{\text{REF}} = \text{GND}$, Adjustable Gain = 4, $T_A = -40^\circ\text{C}$ to $+125^\circ\text{C}$		$V_{\text{GND}} + 5$	$V_{\text{GND}} + 10$	mV
	Swing to Ground	$R_L = 10\text{k}\Omega$ to GND, $V_{\text{REF}} = \text{GND}$, $T_A = -40^\circ\text{C}$ to $+125^\circ\text{C}$		$V_{\text{GND}} + 1$	$V_{\text{GND}} + 5$	mV
FREQUENCY RESPONSE						
BW	Bandwidth (current sense amplifier only)	-3dB Bandwidth, $V_{\text{FB}} = V_{\text{OUT}}$		1		MHz
		-3dB Bandwidth, Adjustable Gain = 4		0.5		MHz
	Propagation delay ⁽³⁾	$V_{\text{IN+}}, V_{\text{IN-}} = 48\text{V}$, Adjustable Gain = 1, $V_{\text{REF}} = 150\text{mV}$, Load Step = 0A to 20A		0.250		μs
	Total Settling time (current in to out)	$V_{\text{IN+}}, V_{\text{IN-}} = 48\text{V}$, Adjustable Gain = 1, $V_{\text{REF}} = 150\text{mV}$, Load Step = 0A to 20A, Output settles to 1%		5		μs
SR	Slew Rate	$V_{\text{FB}} = V_{\text{OUT}}$		1.8		V/ μs
		Adjustable Gain = 4		1.5		V/ μs
NOISE						
	Current Noise Density			150		$\mu\text{A}/\sqrt{\text{Hz}}$
POWER SUPPLY						
I_Q	Quiescent current			3.5	4.25	mA
		$T_A = -40^\circ\text{C}$ to $+125^\circ\text{C}$			4.5	mA
TEMPERATURE						
T_{Alert}	Thermal Alert Threshold	$R_{\text{pullup}} = 10\text{k}\Omega$,		160		$^\circ\text{C}$
$V_{\text{OL-Alert}}$	Thermal Alert Low-level output voltage	$R_{\text{pullup}} = 10\text{k}\Omega$,			200	mV

(1) This is inclusive of Power Coefficient Gain Non-linearity Error

 (2) $I_{\text{SENSE}} = \pm 5\text{A}$ to $\pm 50\text{A}$, $V_{\text{OUT}} = V_{\text{REF}} \pm 1\text{V}$

(3) Propagation delay is difference of time between 10% of load step to 10% of final output settling value

5.6 Typical Characteristics

at $T_A = 25^\circ\text{C}$, $V_S = 5\text{V}$, $I_{\text{SENSE}} = I_{\text{S}+} = 0\text{A}$, $V_{\text{CM}} = 48\text{V}$, $V_{\text{FB}} = V_{\text{OUT}}$, and $V_{\text{REF}} = V_S / 2$ (unless otherwise noted)

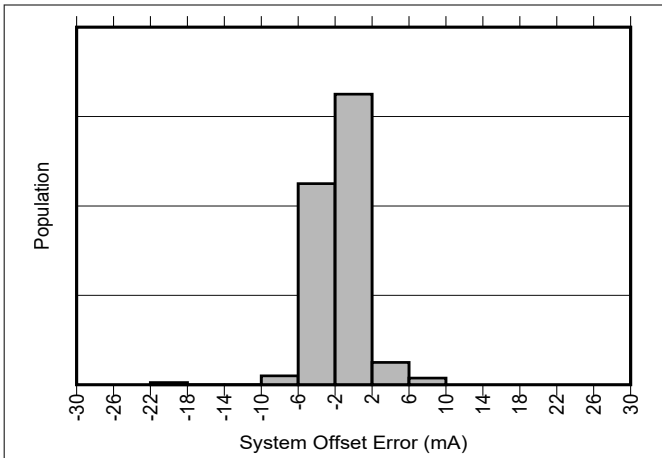

Figure 5-1. INA791A-Q1 Input Offset Current Production Distribution

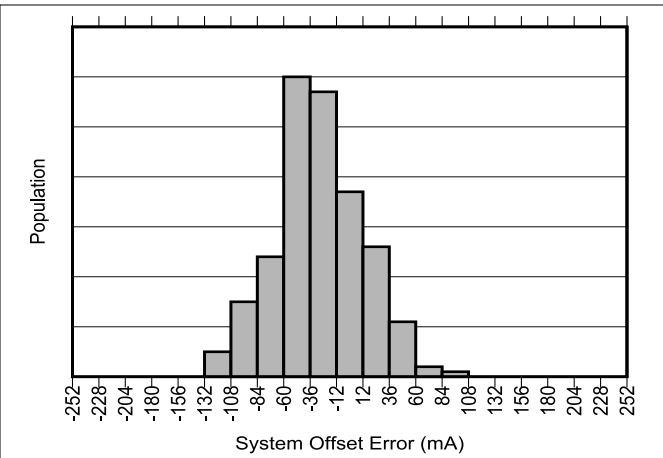

Figure 5-2. INA791B-Q1 Input Offset Current Production Distribution

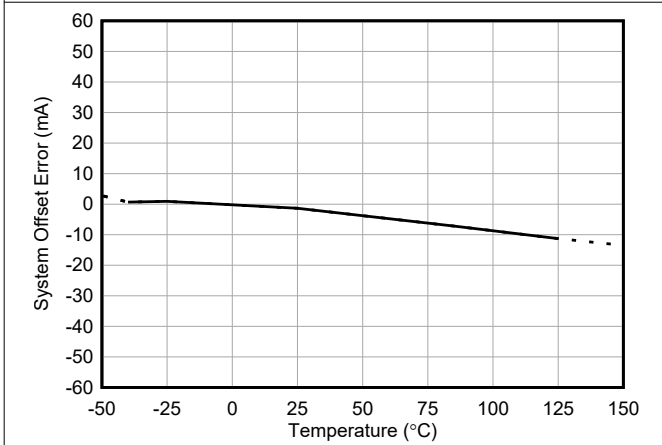

Figure 5-3. INA791A-Q1 Input Offset Current vs Temperature

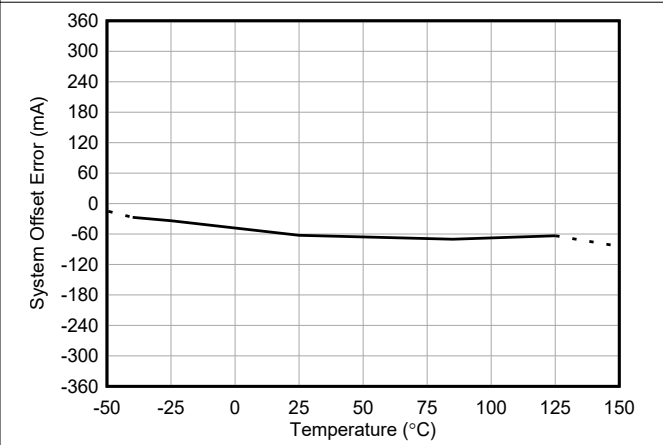

Figure 5-4. INA791B-Q1 Input Offset Current vs Temperature

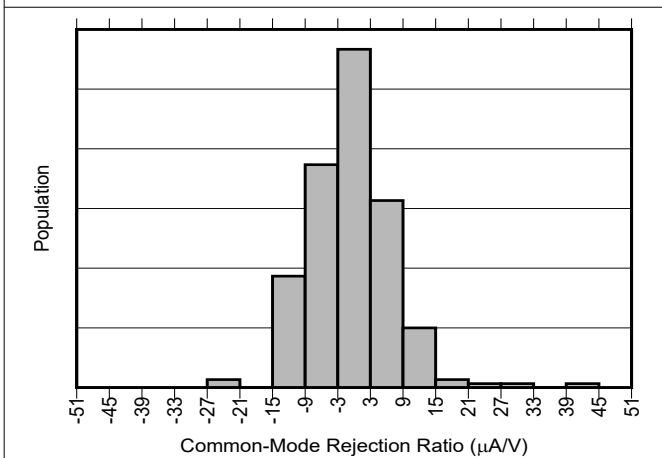

Figure 5-5. INA791A-Q1 Common-Mode Rejection Production Distribution

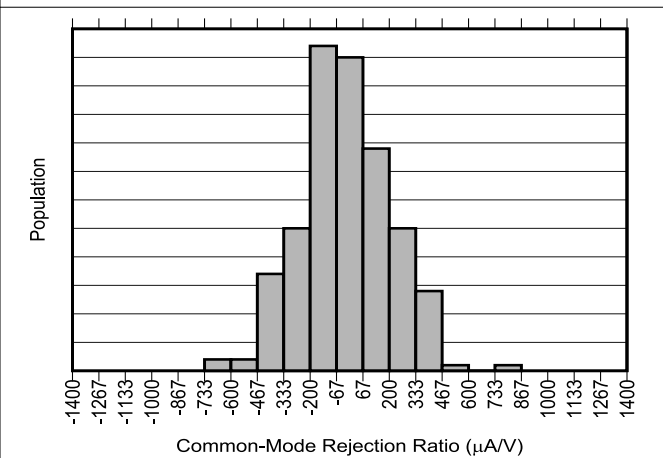

Figure 5-6. INA791B-Q1 Common-Mode Rejection Production Distribution

5.6 Typical Characteristics (continued)

at $T_A = 25^\circ\text{C}$, $V_S = 5\text{V}$, $I_{\text{SENSE}} = I_{S+} = 0\text{A}$, $V_{\text{CM}} = 48\text{V}$, $V_{\text{FB}} = V_{\text{OUT}}$, and $V_{\text{REF}} = V_S / 2$ (unless otherwise noted)

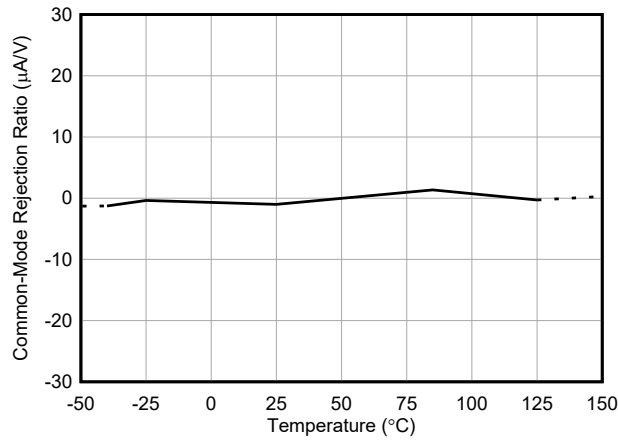

Figure 5-7. Common-Mode Rejection Ratio vs Temperature

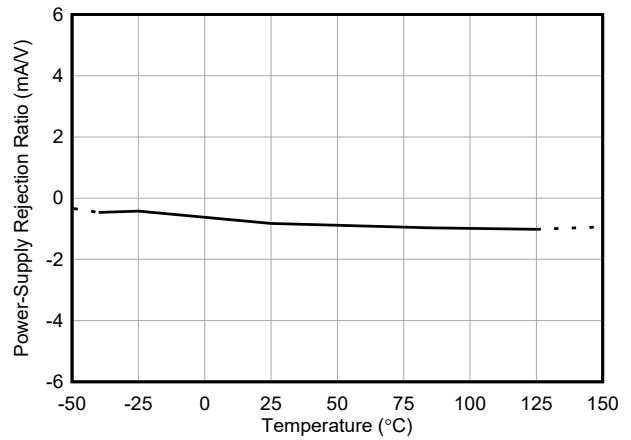

Figure 5-8. Power-Supply Rejection Ratio vs Temperature

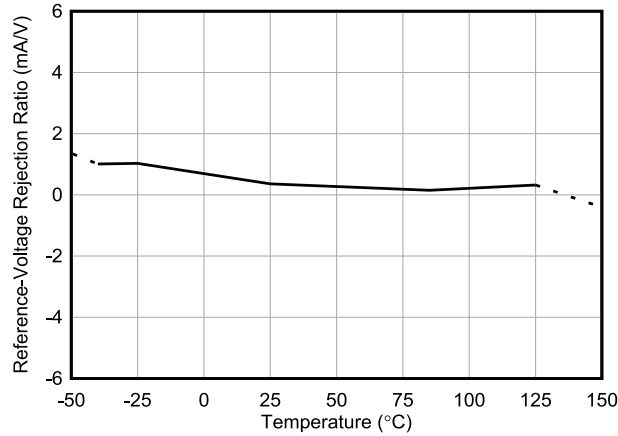

Figure 5-9. Reference Voltage Rejection Ratio vs Temperature

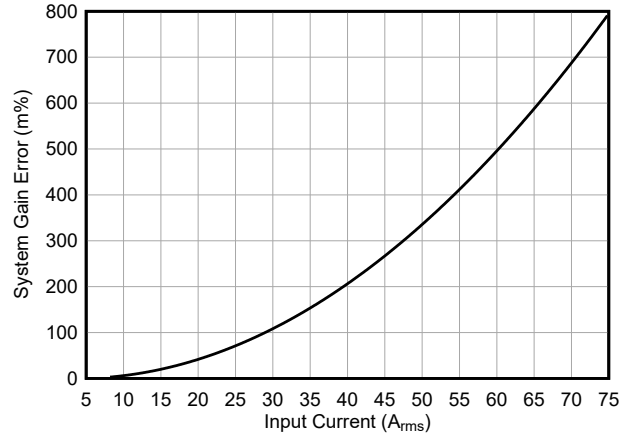

Figure 5-10. System Gain Error vs Input Current

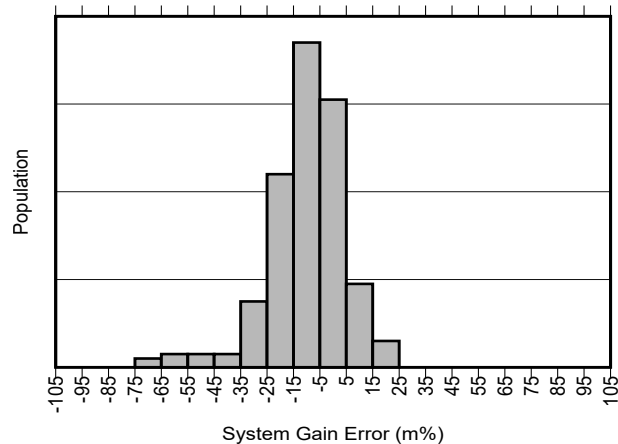

Figure 5-11. INA791A-Q1 Gain Error Production Distribution

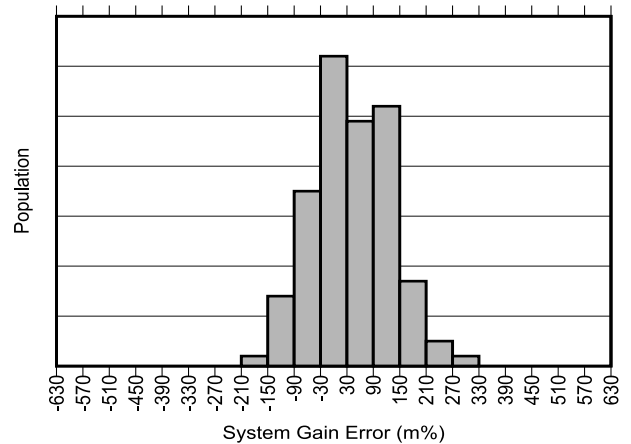

Figure 5-12. INA791B-Q1 Gain Error Production Distribution

5.6 Typical Characteristics (continued)

at $T_A = 25^\circ\text{C}$, $V_S = 5\text{V}$, $I_{\text{SENSE}} = I_{S+} = 0\text{A}$, $V_{\text{CM}} = 48\text{V}$, $V_{\text{FB}} = V_{\text{OUT}}$, and $V_{\text{REF}} = V_S / 2$ (unless otherwise noted)

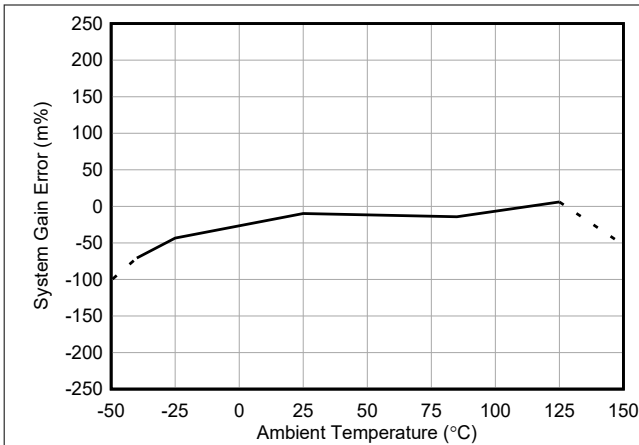

Figure 5-13. INA791A-Q1 Gain Error vs Temperature

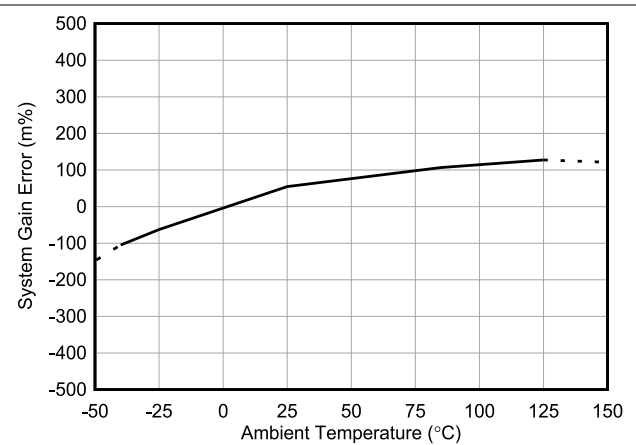
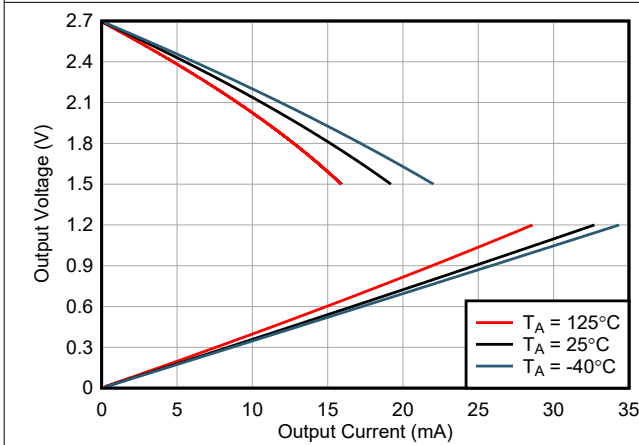
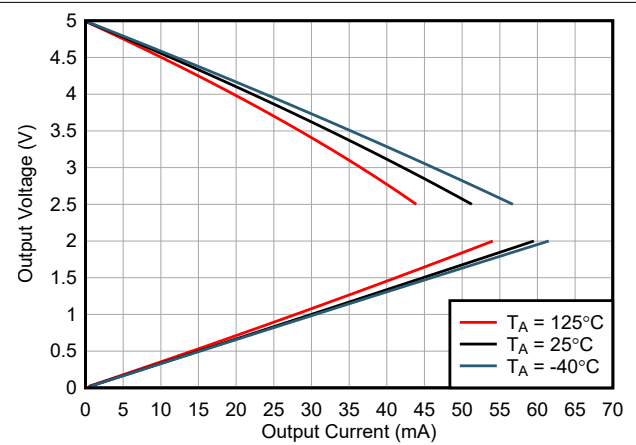

Figure 5-14. INA791B-Q1 Gain Error vs Temperature



$V_S = 2.7\text{V}$

Figure 5-15. Output Voltage Swing vs Output Current



$V_S = 5\text{V}$

Figure 5-16. Output Voltage Swing vs Output Current

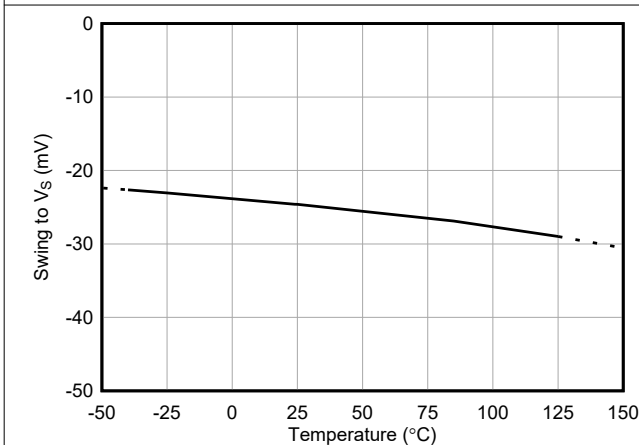

Adjustable Gain = 4, $V_{\text{REF}} = V_S$

Figure 5-17. Output Voltage Swing High vs Temperature

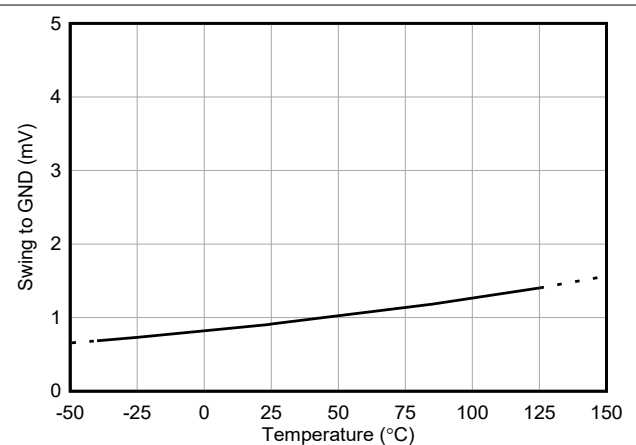

Adjustable Gain = 1, $V_{\text{REF}} = \text{GND}$

Figure 5-18. Output Voltage Swing Low vs Temperature

5.6 Typical Characteristics (continued)

at $T_A = 25^\circ\text{C}$, $V_S = 5\text{V}$, $I_{\text{SENSE}} = I_{S+} = 0\text{A}$, $V_{\text{CM}} = 48\text{V}$, $V_{\text{FB}} = V_{\text{OUT}}$, and $V_{\text{REF}} = V_S / 2$ (unless otherwise noted)

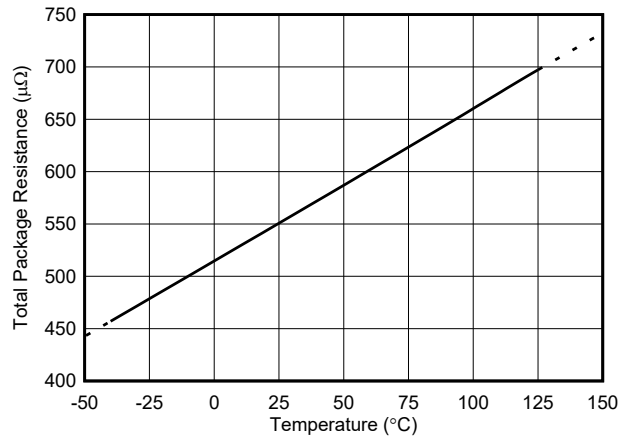

Figure 5-19. Package Resistance vs Temperature

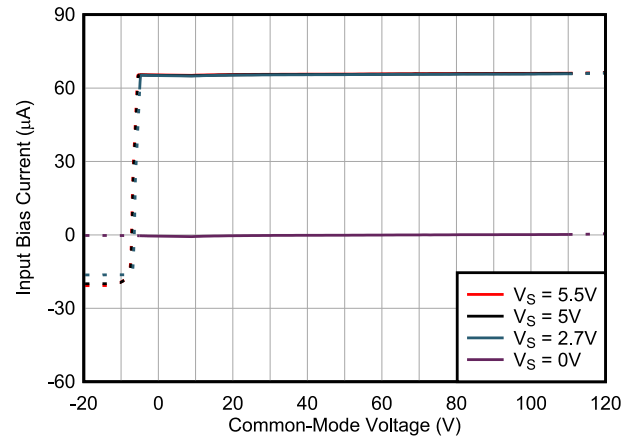

Figure 5-20. Total Input Bias Current vs Common-Mode Voltage

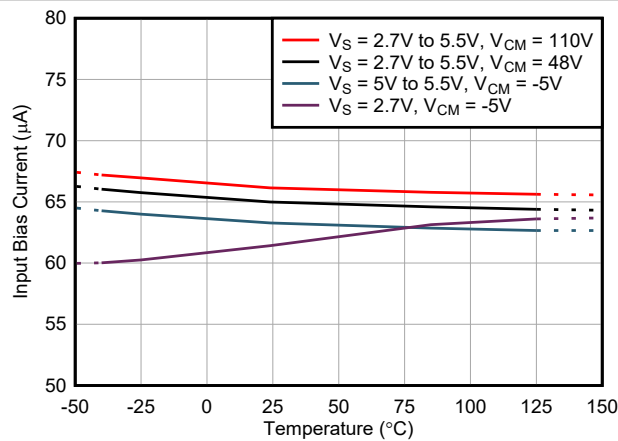

Figure 5-21. Total Input Bias Current vs Temperature

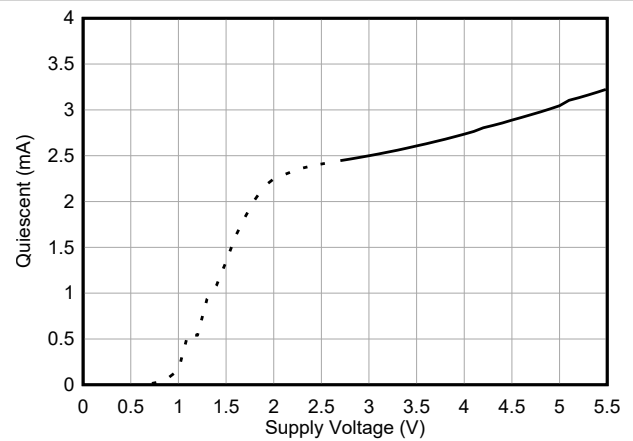

Figure 5-22. Quiescent Current vs Supply Voltage

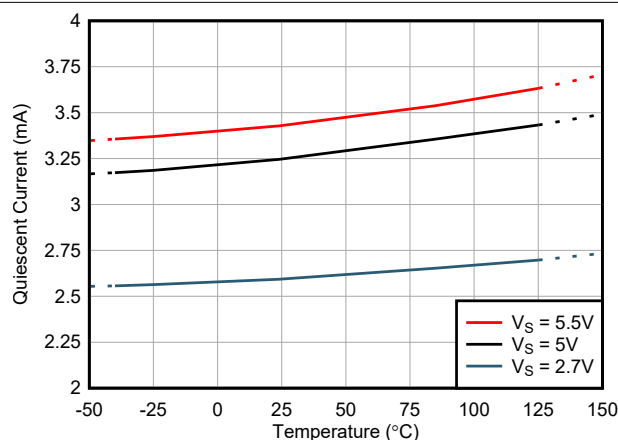

Figure 5-23. Quiescent Current vs Temperature

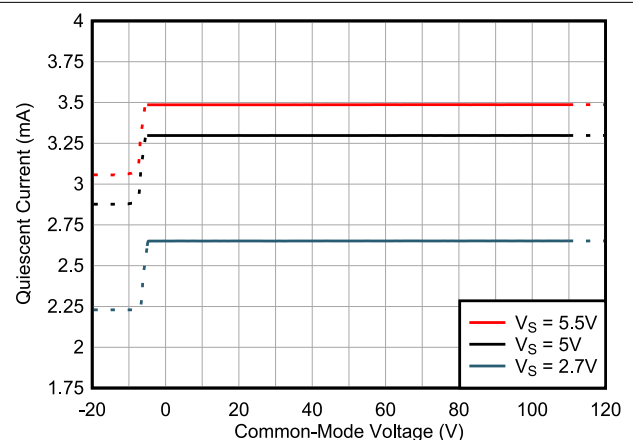

Figure 5-24. Quiescent Current vs Common-Mode Voltage

5.6 Typical Characteristics (continued)

at $T_A = 25^\circ\text{C}$, $V_S = 5\text{V}$, $I_{\text{SENSE}} = I_{S+} = 0\text{A}$, $V_{\text{CM}} = 48\text{V}$, $V_{\text{FB}} = V_{\text{OUT}}$, and $V_{\text{REF}} = V_S / 2$ (unless otherwise noted)

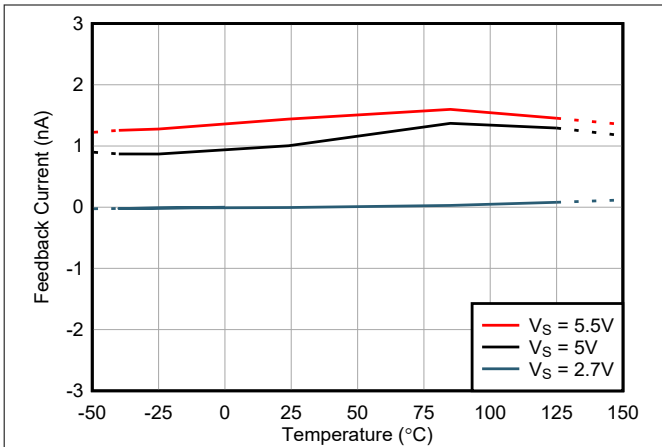

Figure 5-25. Feedback Current vs Temperature

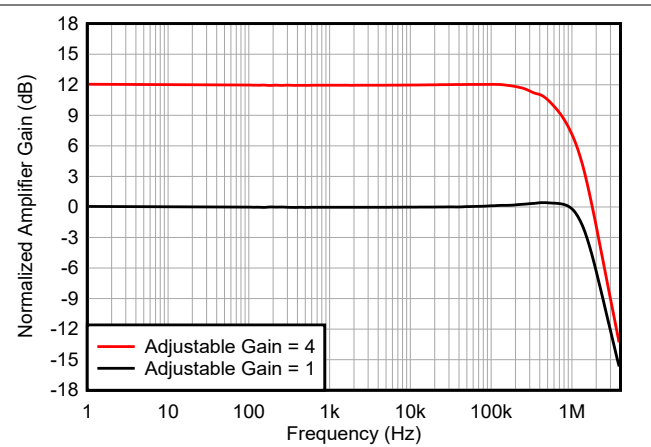

Figure 5-26. Current Sense Amplifier Gain vs Frequency

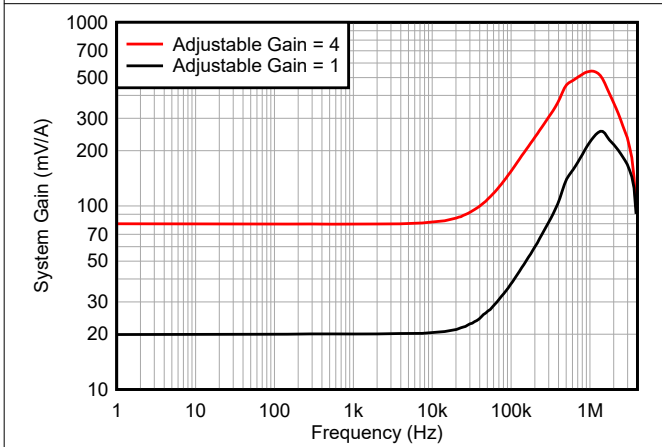

Figure 5-27. System Gain vs Frequency

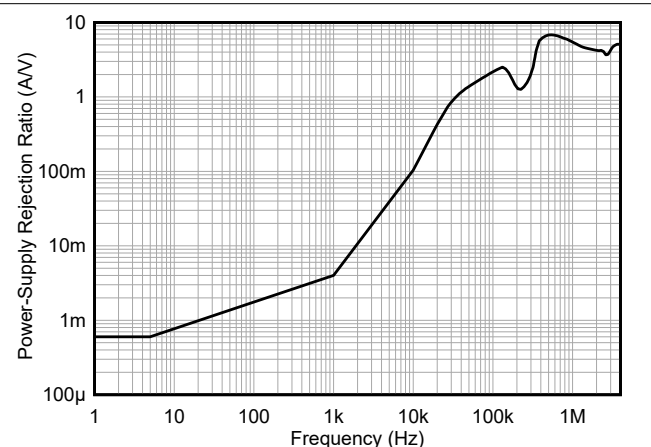

Figure 5-28. Power-Supply Rejection Ratio vs Frequency

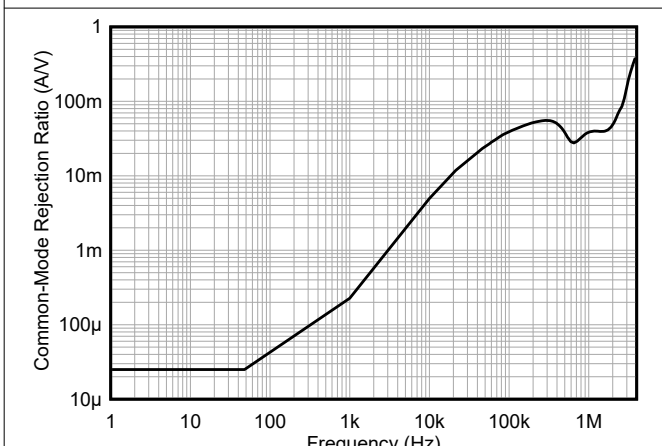

Figure 5-29. Common-Mode Rejection Ratio vs Frequency

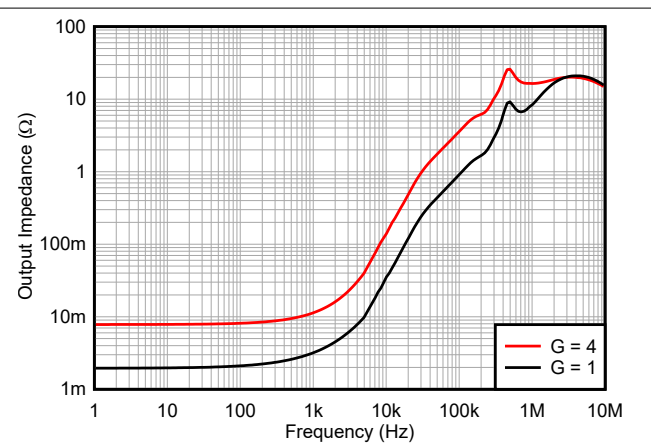

Figure 5-30. Output Impedance vs Frequency

5.6 Typical Characteristics (continued)

at $T_A = 25^\circ\text{C}$, $V_S = 5\text{V}$, $I_{\text{SENSE}} = I_{S+} = 0\text{A}$, $V_{\text{CM}} = 48\text{V}$, $V_{\text{FB}} = V_{\text{OUT}}$, and $V_{\text{REF}} = V_S / 2$ (unless otherwise noted)

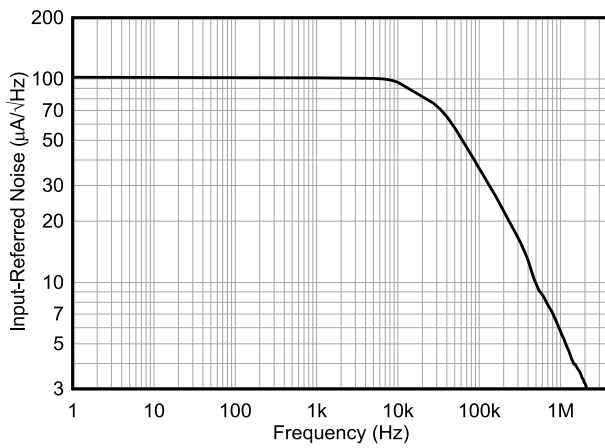

Figure 5-31. Input-Referred Current Noise vs Frequency

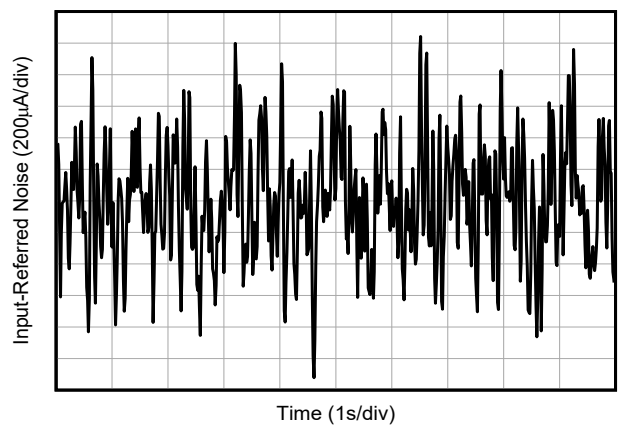
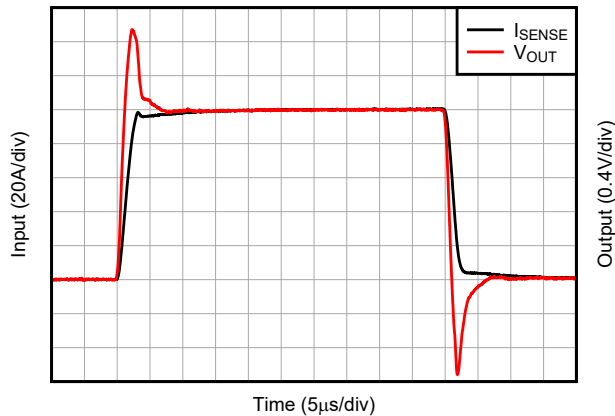

Figure 5-32. 0.1Hz to 10Hz Input-Referred Current Noise



$V_{\text{REF}} = 1\text{V}$, 100A input step

Figure 5-33. System Current Step Response

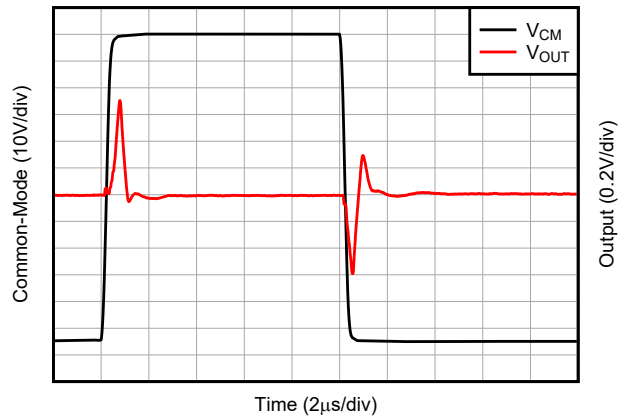
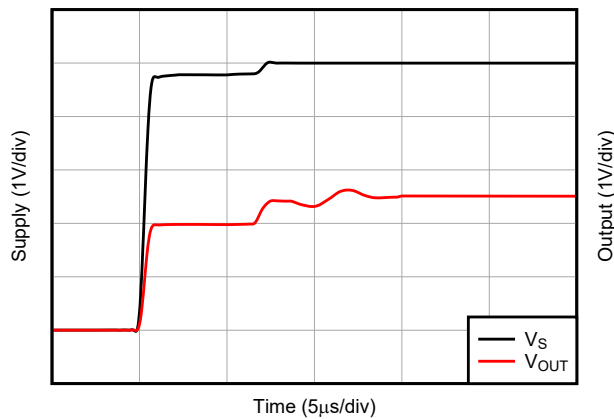

Figure 5-34. Common-Mode Transient Response



$V_{\text{REF}} = 0\text{V}$

Figure 5-35. Start-Up Response

6 Detailed Description

6.1 Overview

The INA791x-Q1 features a precision current sensing design with 400 $\mu\Omega$ current-sensing EZShunt™ technology resistor and supports common-mode voltages up to 110V. The internal amplifier features a precision zero-drift topology with excellent common-mode rejection ratio (CMRR). High-precision measurements are enabled by matching the shunt resistor value and the current-sensing amplifier gain across temperature, thus providing a highly-accurate, system-calibrated method for measuring current. The high-speed current-sensing amplifier helps output settle fast after the common-mode transients. Flexibility of adjustable gain with two external resistors allows for the optimization of the desired full-scale output voltage based on the target current range expected in the application.

6.2 Functional Block Diagram

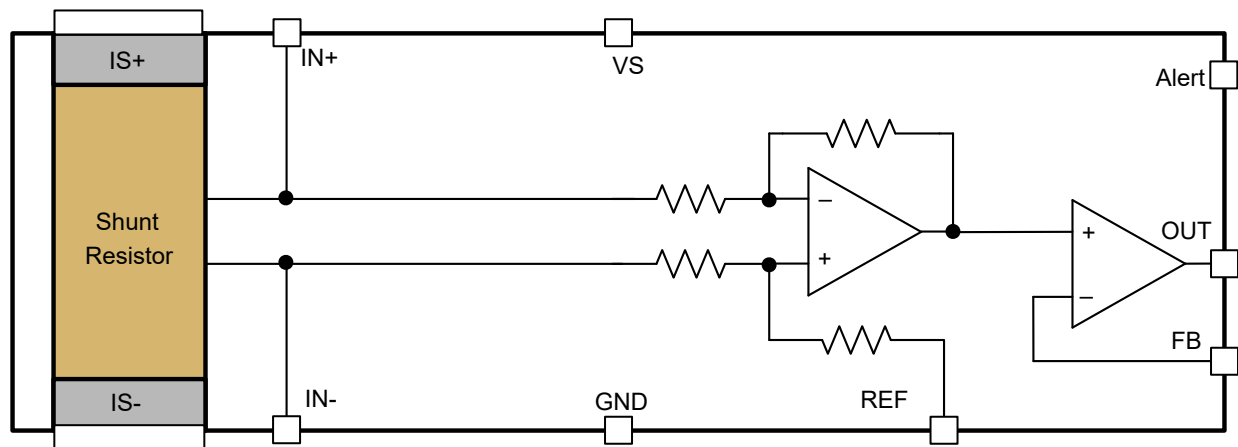

6.3 Feature Description

6.3.1 Integrated Shunt Resistor

The INA791x-Q1 features an integrated EZShunt™ technology current-sensing resistor that provides accurate measurements over the entire specified temperature range of -40°C to $+125^{\circ}\text{C}$. The integrated current-sensing resistor provides measurement stability over temperature, and simplifies printed circuit board (PCB) layout and board constraint difficulties common in high-precision measurements.

The onboard current-sensing resistor is designed as a 4-wire (or Kelvin) connected resistor that enables accurate measurements through a force-sense connection. Amplifier input pins (IN– and IN+) connected internally to the sense point of the shunt resistor eliminates many instances of parasitic impedance commonly found in typical very-low sensing-resistor level measurements. The INA791x-Q1 is system-calibrated to make sure that the current-sensing resistor and current-sensing amplifier are both precisely matched to one another. The in-package integrated sensing resistor must be used with the internal current-sensing amplifier to achieve the optimized system gain specification.

The INA791x-Q1 has approximately 550 $\mu\Omega$ of package resistance. Of this total package resistance, 400 $\mu\Omega$ resistance from the Kelvin-connected current-sensing resistor is used by the amplifier. The power dissipation requirements of the system and package are based on the total 550 $\mu\Omega$ package resistance between the IS+ and IS– pins.

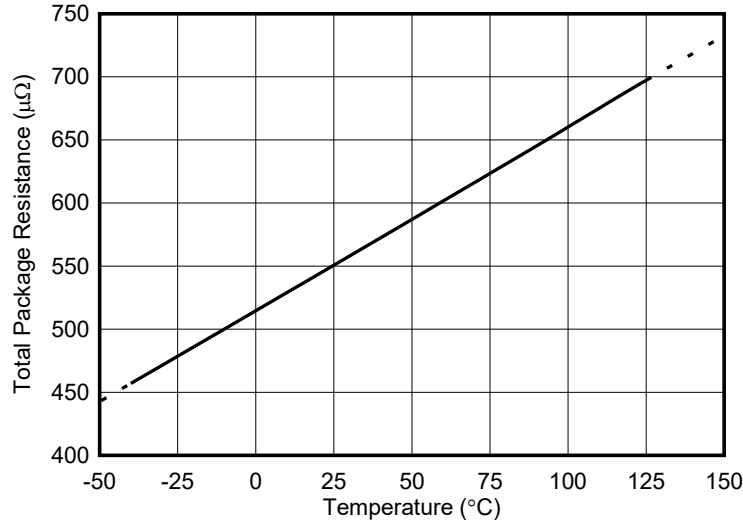

Figure 6-1. IS+ to IS- Package Resistance vs Temperature

6.3.2 Safe Operating Area

The heat dissipated across the package when current flows through the device ultimately determines the maximum current that can be safely handled by the package. The current consumption of the silicon is relatively low, leaving the total package resistance to carry the high load current as the primary contributor to the total power dissipation of the package. The maximum safe-operating current level shown in Figure 6-2 is set to make sure that the heat dissipated across the package is limited so that no damage occurs to the resistor or the package, or that the internal junction temperature of the silicon does not exceed a 165°C limit.

External factors, such as ambient temperature, external air flow, and PCB layout, contribute to how effectively the device dissipates heat. The internal heat is developed as a result of the current flowing through the total package resistance of 550μΩ.

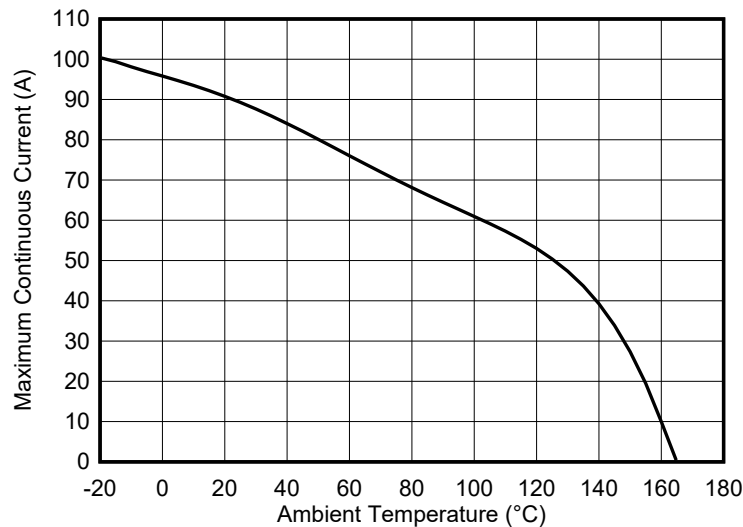

Figure 6-2. Maximum Continuous Current vs Ambient Temperature

6.3.3 Short-Circuit Duration

The INA791x-Q1 features a physical shunt resistance that is able to withstand current levels higher than the continuous handling limit of 50A without sustaining damage to the current-sensing resistor or the current-sensing amplifier, if the excursions are brief. Figure 6-3 shows the short-circuit duration curve for the INA791x-Q1 .

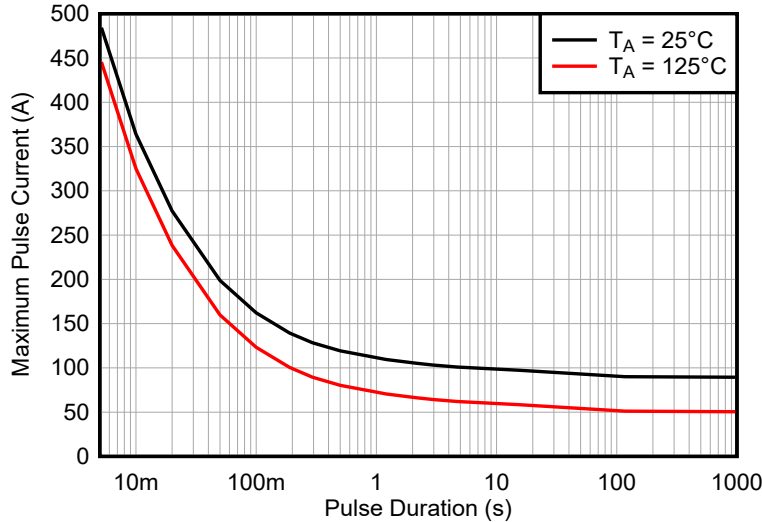

Figure 6-3. Maximum Pulse Current vs Pulse Duration (Single Event)

6.3.4 Temperature Drift Correction

System calibration is common for many industrial applications to eliminate initial component and system-level errors that can be present. A system-level calibration reduces the initial accuracy requirement for many of the individual components because the errors associated with these components are effectively eliminated through the calibration procedure. This calibration enables precise measurements at the temperature in which the system is calibrated. As the system temperature changes because of external ambient changes or self heating, measurement errors are reintroduced. Without accurate temperature compensation used in addition to the initial adjustment, the calibration procedure is not effective. The user must account for temperature-induced changes. The built-in programmed temperature compensation in the INA791x-Q1 (including both the integrated current-sensing resistor and current-sensing amplifier) keep the device measurement accurate, even when the temperature changes throughout the specified temperature range of the device.

6.4 Device Functional Modes

6.4.1 Adjusting the Output With the Reference Pin

The INA791x-Q1 output is configurable to allow for unidirectional or bidirectional operation. Figure 6-4 shows a circuit for setting output with an external reference.

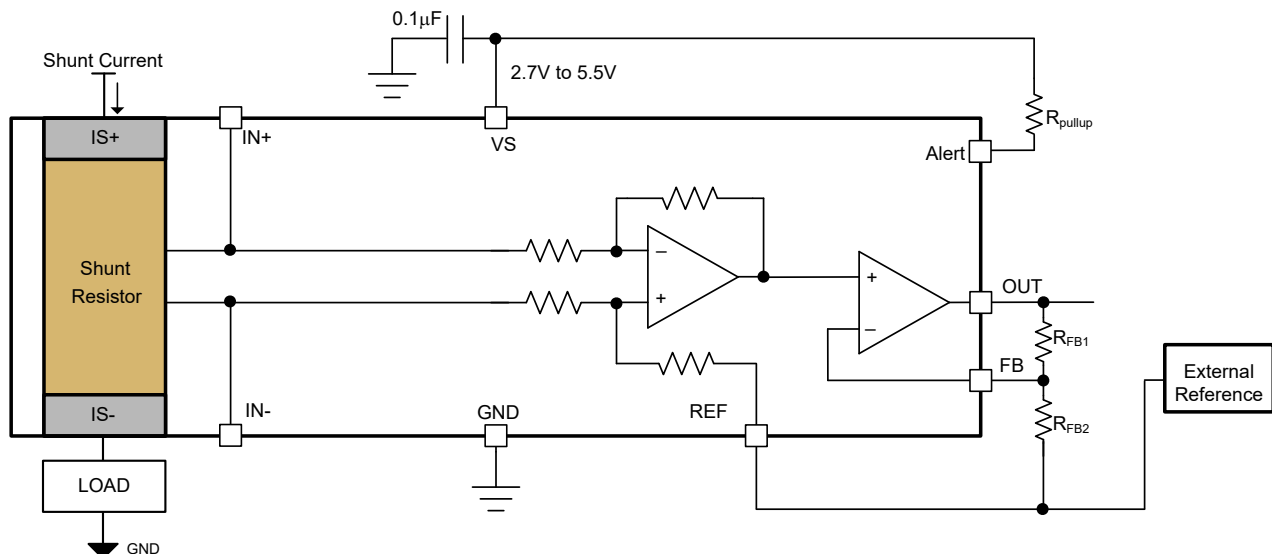

Figure 6-4. Adjusting the Output

The output voltage is set by applying a voltage from an external reference at REF. The reference input is connected to internal gain network. The external resistor network of R_{FB1} and R_{FB2} , connected to OUT, FB and REF pins, set up adjustable gain as explained in [Adjustable Gain Set Using External Resistors](#). Output is set accurately at the voltage provided by external reference as shown in [Equation 1](#) when the resistor R_{FB2} is connected to the same voltage as REF pin. The voltage at REF pin can range between supply V_S and GND. For symmetric bidirectional current sensing REF is set at mid-supply which sets out at mid-supply as well.

$$V_{OUT} = G \times (I_{SHUNT}) + V_{REF} \quad (1)$$

6.4.1.1 Reference Pin Connections for Unidirectional Current Measurements

Unidirectional operation allows current measurements through a resistive shunt in one direction. For unidirectional operation, connect the device reference pin to the negative rail (see the [Ground Referenced Output](#) section) or positive rail, V_S . The required differential input polarity depends on the output voltage setting. The amplifier output moves away from the referenced rail proportional to the current passing through the internal shunt resistor.

6.4.1.2 Ground Referenced Output

When using the INA791x-Q1 in unidirectional mode with a ground-referenced output, both REF input and resistor R_{FB2} are connected to ground. [Figure 6-5](#) shows how this configuration takes the output to ground when there is 0A flowing across the internal shunt.

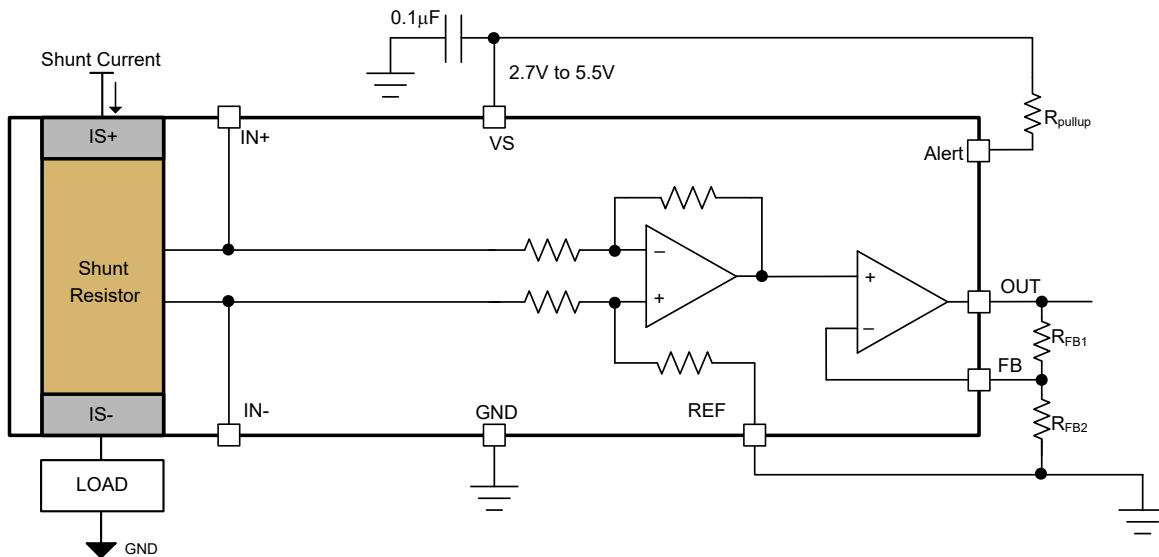

Figure 6-5. Ground-Referenced Output

6.4.1.3 Reference Pin Connections for Bidirectional Current Measurements

Bidirectional operation allows the INA791x-Q1 to measure currents through a resistive shunt in two directions. For this case, set the output voltage anywhere within the reference input limits. A common configuration is to set the reference inputs at half-scale for equal range in both directions. However, the reference input can be set to a voltage other than half-scale when the bidirectional current is not symmetrical.

6.4.1.4 Output Set to Mid-Supply Voltage

[Figure 6-6](#) shows two equal resistors R_1 and R_2 connected between V_S and the GND pins divide the supply at half, and by connecting REF pin to the divided supply, output is set to mid-supply voltage. The mid-point of these resistors is buffered using external operational amplifier to avoid loading of resistors resulting in error. The output is set to middle of the supply when there is no differential input voltage or 0A current in shunt resistor. This method creates a ratiometric offset to the supply voltage, where the output voltage remains at $V_S / 2$ when 0A of current flows through internal shunt resistor.

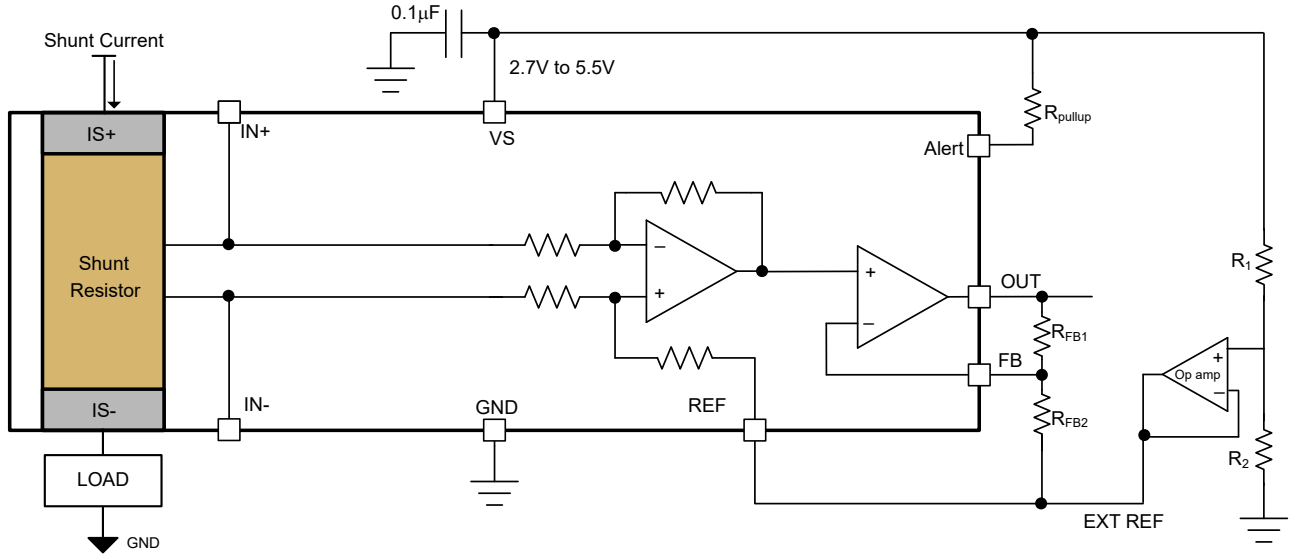

Figure 6-6. Mid-Supply Voltage Output

6.4.2 Adjustable Gain Set Using External Resistors

The INA791x-Q1 features adjustable gain with two external resistor network. The default gain is 20mV/A, and with added external adjustable gain resistor network, total gain (G) can range up to 400mV/A. Figure 6-7 shows two external resistors R_{FB1} and R_{FB2} configured for added external gain. Equation 2 can be used for calculating external adjustable gain and Equation 3 shows the total gain of the system with external adjustable gain. The REF pin and one end of resistor R_{FB2} is connected to external reference based on needed voltage at OUT pin as described in [Adjusting the Output With the Reference Pin](#).

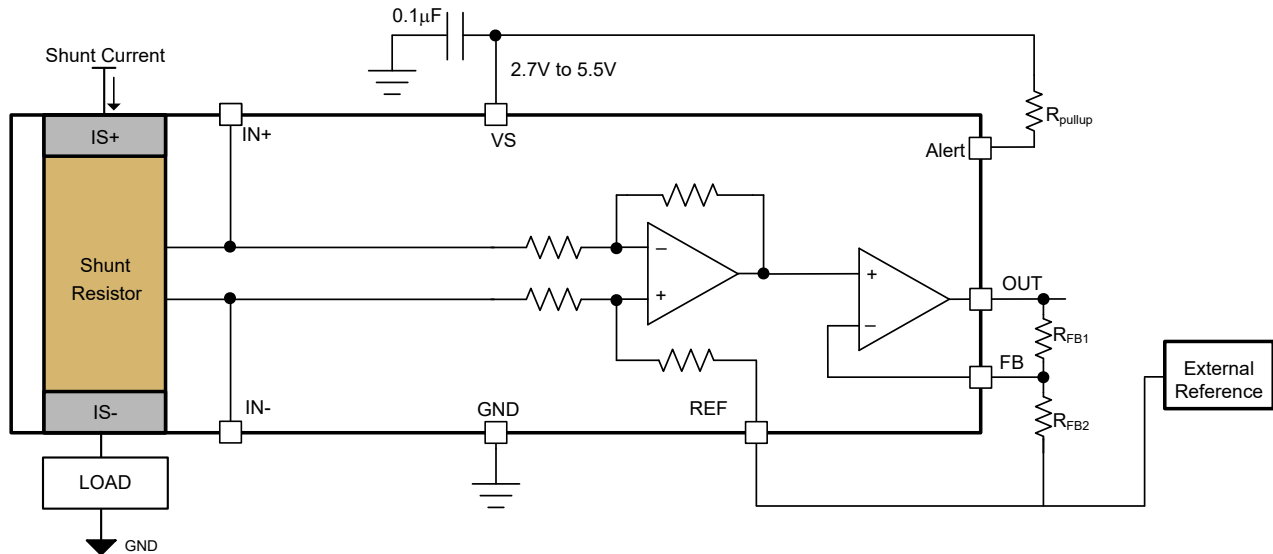

Figure 6-7. Adjustable Gain Setting With External Resistor Divider

$$\text{Adjustable Gain} = \left(1 + \frac{R_{FB1}}{R_{FB2}} \right) \quad (2)$$

$$G = 20 \frac{\text{mV}}{\text{A}} \times \left(1 + \frac{R_{FB1}}{R_{FB2}} \right) \quad (3)$$

The FB pin in INA791x-Q1 has associated bias current, which can add to error when large values of adjustable gain resistor, R_{FB1} , is used. Alternatively, very low values of adjustable gain resistors load the output of the sense amplifier limiting the capability of the sense amplifier to get close to the supply rail. Keeping the sum of external resistors R_{FB1} and R_{FB2} between 10k Ω and 40k Ω is recommended when external adjustable gain is higher than 1. [Table 6-1](#) shows recommended values of external gain resistors for the most common gains.

Table 6-1. Recommended Values of External Resistors Setting Adjustable Gain

External Adjustable Gain	R_{FB1}	R_{FB2}	Total Gain (G)
1	0 Ω (short)	Open	20mV/A
2	20k Ω	20k Ω	40mV/A
4	30k Ω	10k Ω	80mV/A
5	20k Ω	5k Ω	100mV/A

6.4.2.1 Adjustable Unity Gain

[Figure 6-8](#) shows adjustable gain set to unity gain or 1. In this configuration OUT is connected to FB without any external resistor. This unity gain sets INA791x-Q1 to default minimum gain of 20mV/A. [Equation 3](#) can be used to calculate the total gain of the system. The REF pin is connected to external reference based on needed output voltage setting as described in [Adjusting the Output With the Reference Pin](#).

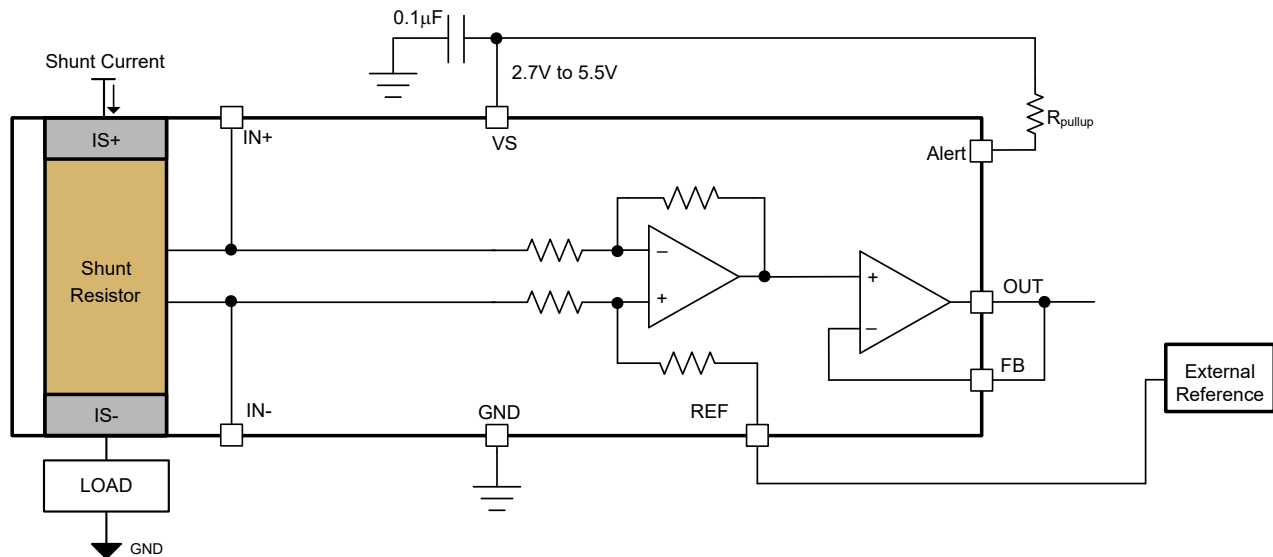

Figure 6-8. Adjustable Unity Gain Setting

6.4.3 Thermal Alert Function

The INA791x-Q1 has thermal Alert function that provides an alert when internal shunt temperature reaches 160°C. The power dissipation as a result of internal shunt current causes the temperature to rise inside the package. Extended time at temperature higher than 150°C can cause permanent shift in device specification. Thermal alert function can be used to keep the temperature of INA791x-Q1 below 150°C. [Figure 6-9](#) shows a circuit where R_{pullup} resistor is tied between open-drain Alert pin and the supply pin. When temperature of the INA791x-Q1 reaches 160°C, the open-drain FET pulls Alert pin to the ground asserting thermal alert.

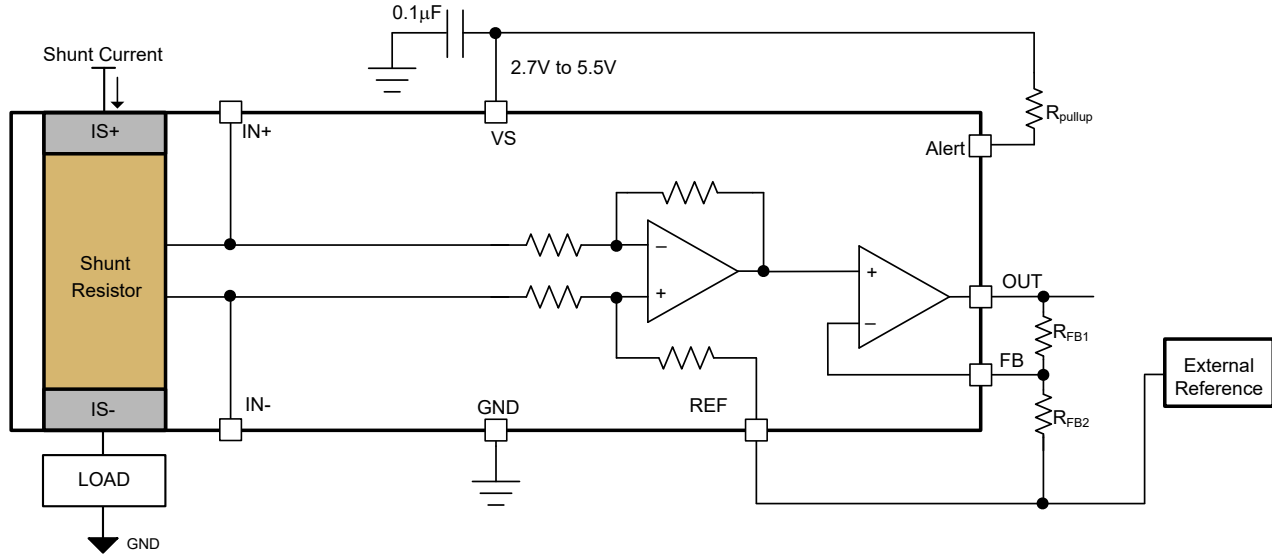

Figure 6-9. Thermal Alert Function

7 Application and Implementation

Note

Information in the following applications sections is not part of the TI component specification, and TI does not warrant its accuracy or completeness. TI's customers are responsible for determining suitability of components for their purposes, as well as validating and testing their design implementation to confirm system functionality.

7.1 Application Information

The INA791x-Q1 measures the voltage developed as current flows across the integrated current shunt. The device provides a reference pin to configure operation as either unidirectional or bidirectional output swing. When using the INA791x-Q1 for inline motor current sense or measuring current in an H-bridge, the device is commonly configured for bidirectional operation.

7.1.1 Calculating Total Error

The INA791x-Q1 electrical specifications [Electrical Characteristics](#) include typical individual errors terms (such as gain error, offset error, and nonlinearity error). Total error, including all of these individual error components, is not specified in the table. To accurately calculate the expected error of the device, the user must first know the device operating conditions. This section discusses the individual error sources and how the device total error value can be calculated from the combination of these errors for specific conditions.

Three examples are provided in [Table 7-1](#), [Table 7-2](#), and [Table 7-3](#) that detail how different operating conditions can affect the total error calculations. Typical and maximum calculations are shown as well to provide the user more information on how much error variance is present from device to device.

7.1.1.1 Error Sources

The typical error sources that have the largest effect on the total error of the device are gain error, nonlinearity, common-mode rejection ratio, and input offset error. For the INA791x-Q1, an additional error source (referred to as the *reference voltage rejection ratio*) is also included in the total error value.

7.1.1.2 Reference Voltage Rejection Ratio Error

Reference voltage rejection ratio refers to the amount of error induced by applying a reference voltage to the INA791x-Q1 that deviates from the mid-point of the device supply voltage.

7.1.1.3 External Adjustable Gain Error

The INA791x-Q1 features external adjustable gain with two external resistors as described in [Adjustable Gain Set Using External Resistors](#). The tolerance of these external resistors contribute to the total gain error of the system. These resistors are recommended to be of same kind so that temperature drift of these resistor track closely. [Equation 4](#) can be used for calculating total error contributed by two external gain resistors.

$$Error_{G_R} = \sqrt{2} * (Resistor_{Tolerance} + Resistor_{drift} \times \Delta T) \quad (4)$$

7.1.1.4 Total Error Example 1

Table 7-1. Total Error Calculation: Example 1 ⁽¹⁾

TERM	SYMBOL	EQUATION	MAX VALUE
Initial input offset with Temp drift	I _{OS_T}	I _{OS}	40mA
Added input offset because of common-mode voltage	I _{OS_CM}	CMRR × (V _{CM} - 48V)	0μA
Added input offset because of reference voltage	I _{OS_REF}	RVRR × (V _S /2 - V _{REF})	0μA

Table 7-1. Total Error Calculation: Example 1 ⁽¹⁾ (continued)

TERM	SYMBOL	EQUATION	MAX VALUE
Total input offset Current	I_{OS_Total}	$\sqrt{(I_{OS_T})^2 + (I_{OS_CM})^2 + (I_{OS_REF})^2}$	40mA
Error from input offset	$Error_{I_{OS}}$	$\frac{I_{OS_Total}}{I_{Sense}} \times 100$	0.16%
Gain error with Gain drift	$Error_G$	$G_{Error} + G_{Error_drift} \times \Delta T$	0.35%
Error due to Gain Nonlinearity	$Error_{Lin}$	$G_{Lin_Error} \times I^2 \times 100\%$	0.0937%
Total error	—	$\sqrt{(Error_{I_{OS}})^2 + (Error_G + Error_{Lin})^2}$	0.47%

(1) The data for **Total Error Example 1** is taken with the INA791x-Q1, $V_S = 5V$, $V_{CM} = 48V$, $V_{REF} = V_S / 2$, $T = 25^\circ C$, External Unity Gain ($G = 20mV/A$) and $I_{SENSE} = 25A$.

7.1.1.5 Total Error Example 2

Table 7-2. Total Error Calculation: Example 2 ⁽¹⁾

TERM	SYMBOL	EQUATION	MAX VALUE
Input offset over Temp	I_{OS_T}	I_{OS}	70mA
Added input offset because of common-mode voltage	I_{OS_CM}	$CMRR \times (V_{CM} - 48V) $	2.8mA
Added input offset because of reference voltage	I_{OS_REF}	$RVRR \times \left \left(\frac{V_S}{2} - V_{REF} \right) \right $	31.25mA
Total input offset Current	I_{OS_Total}	$\sqrt{(I_{OS_T})^2 + (I_{OS_CM})^2 + (I_{OS_REF})^2}$	76.7mA
Error from input offset	$Error_{I_{OS}}$	$\frac{I_{OS_Total}}{I_{Sense}} \times 100$	0.306%
Gain error with Gain drift	$Error_G$	$G_{Error} + G_{Error_drift} \times \Delta T$	0.7%
Error due to Gain Nonlinearity	$Error_{Lin}$	$G_{Lin_Error} \times I^2 \times 100\%$	0.0937%
Total error	—	$\sqrt{(Error_{I_{OS}})^2 + (Error_G + Error_{Lin})^2}$	0.85%

(1) The data for **Total Error Example 2** is taken with the INA791x-Q1, $V_S = 5V$, $V_{CM} = 12V$, $V_{REF} = 0V$, $T = 125^\circ C$, External Unity Gain ($G = 20mV/A$) and $I_{SENSE} = 25A$.

7.1.1.6 Total Error Example 3

Table 7-3. Total Error Calculation: Example 3 ⁽¹⁾

TERM	SYMBOL	EQUATION	MAX VALUE
Input offset over Temp	I_{OS_T}	I_{OS}	70mA
Added input offset because of common-mode voltage	I_{OS_CM}	$CMRR \times (V_{CM} - 48V) $	2.8mA
Added input offset because of reference voltage	I_{OS_REF}	$RVRR \times \left \left(\frac{V_S}{2} - V_{REF} \right) \right $	31.25mA
Total input offset Current	I_{OS_Total}	$\sqrt{(I_{OS_T})^2 + (I_{OS_CM})^2 + (I_{OS_REF})^2}$	76.71mA
Error from input offset	$Error_{I_{OS}}$	$\frac{I_{OS_Total}}{I_{Sense}} \times 100$	0.307%
Gain error with Gain drift	$Error_G$	$G_{Error} + G_{Error_drift} \times \Delta T$	0.7%
Error due to Gain Nonlinearity	$Error_{Lin}$	$G_{Lin_Error} \times I^2 \times 100\%$	0.0937%

Table 7-3. Total Error Calculation: Example 3 ⁽¹⁾ (continued)

TERM	SYMBOL	EQUATION	MAX VALUE
External Gain Resistor Error + Drift	Error _{G_R}	Equation 4	0.707%
Total error	—	$\sqrt{(Error_{I_{OS}})^2 + (Error_{G_R})^2 + (Error_G + Error_{Lin})^2}$	1.1%

(1) The data for *Total Error Example 3* is taken with the INA791x-Q1, V_S = 5V, V_{CM} = 12V, V_{REF} = 0V, T = 125°C, External Gain = 4 (Total Gain = 80mV/A), External Resistor Tolerance = 0.25%, External Resistor Drift = 25ppm/°C and I_{SENSE} = 25A.

7.1.1.7 Total Error Curves

INA791A-Q1 and INA791B-Q1 Total Error Curve plots are generated using Total Error Examples for Adjustable Gain of 1 (unity gain).

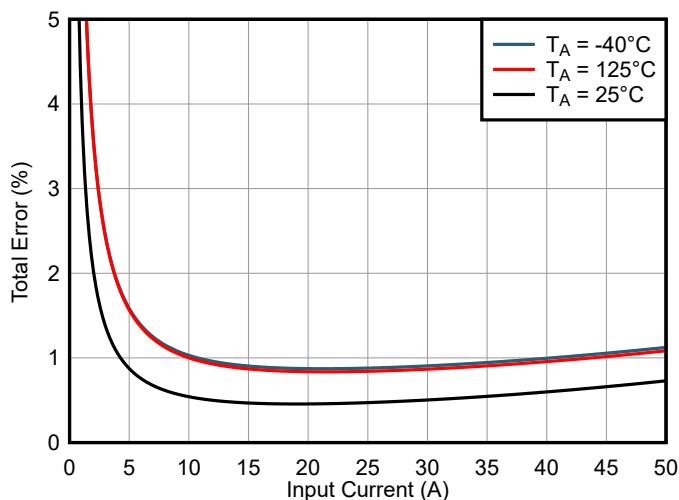

V_{CM} = 48V, V_S = 5V, V_{REF} = 2.5V, Adjustable Gain = 1

Figure 7-1. INA791A-Q1 Total Error vs Input Current

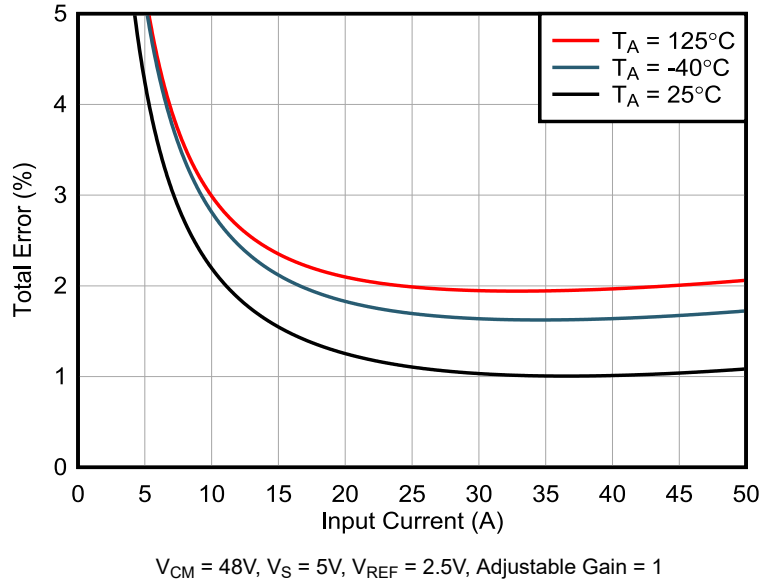

Figure 7-2. INA791B-Q1 Total Error vs Input Current

7.1.2 Signal Filtering

Note that the integrated sensing element has inductance like all low-ohmic shunt resistors. Shunt inductance can lead to shunt voltage overshoots and AC gain peaking, which is undesirable if system requires linear and accurate current measurements when sensing small signal frequencies beyond 100kHz or when system can not tolerate overshoot from fast current step responses such as when comparators are tracking for fast overcurrent events. [Figure 7-3](#) show INA791x-Q1 shunt impedance vs frequency.

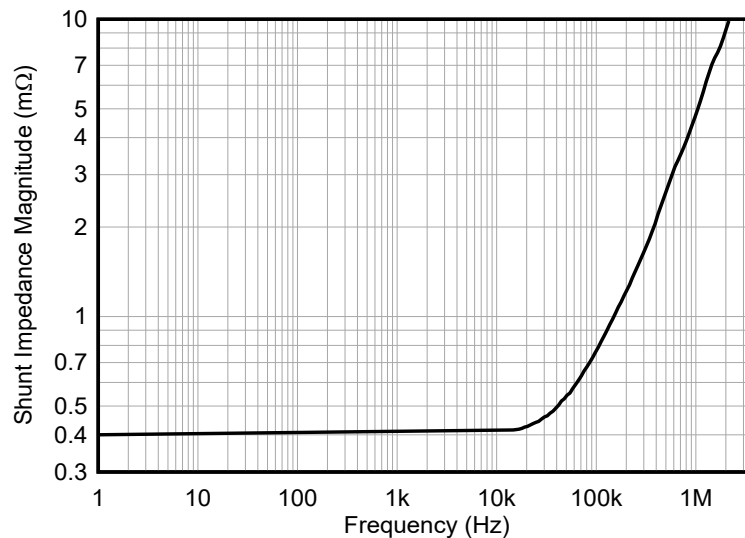

Figure 7-3. Shunt Impedance vs Frequency

Typically, inductance from low-Ohmic shunt resistors can be negated by adding a differential filter that creates a pole to flatten zero introduced from inductance. For the INA791x-Q1 an internal short is provided from Kelvin sense connections to amplifier input to optimize noise, performance and quality. Thus, input resistance on these connections is very low and to apply an input filter, a capacitance between IN+ and IN- that is greater than 22μF is required. The filter capacitor must be placed as close as possible to IN+ and IN- pins. [Figure 7-4](#) shows gain response versus frequency with and without input filter capacitor.

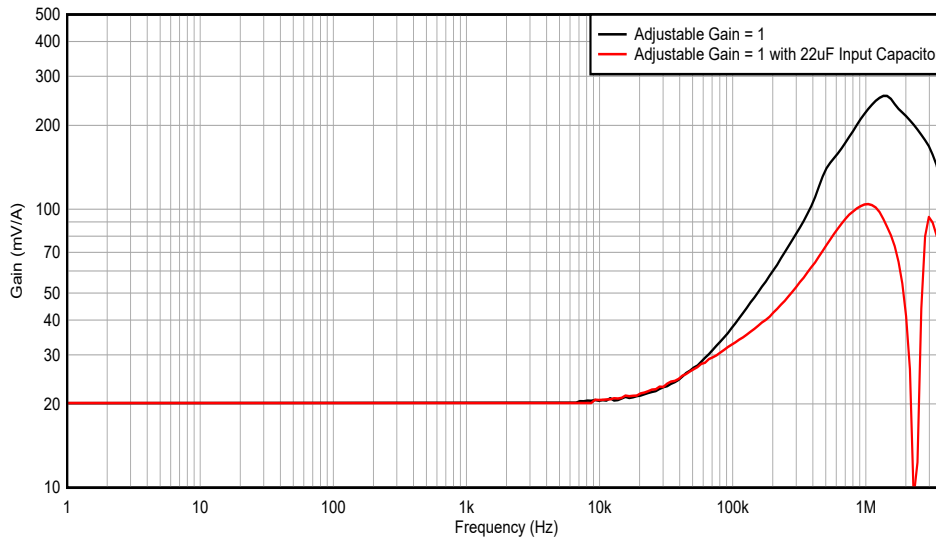

Figure 7-4. INA791x-Q1 Gain vs Frequency Before and After Adding 22µF Input Capacitor

Another option to negate the shunt inductance is to introduce the zero in transfer function at the adjustable gain-setting output buffer with a circuit configuration referred to as a RISO Dual Feedback. This operational amplifier network provides a zero to cancel out shunt inductance without sacrificing overall bandwidth nor output impedance. Figure 7-5 shows RISO Dual Feedback circuit configuration

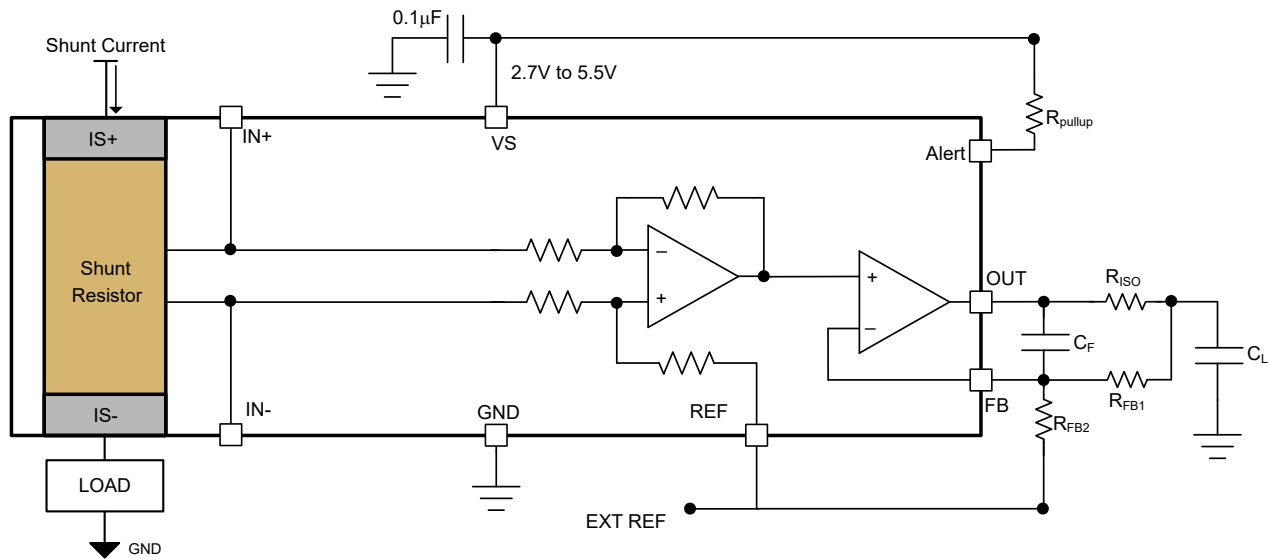

Figure 7-5. INA791x-Q1 With RISO-Dual-Feedback

Based upon measured bandwidth and output impedance, Table 7-4 shows values for circuit components that can be used to achieve the circuit with the desired gain. Resistor tolerances under 2% is recommended. Figure 7-6 and Figure 7-7 show the load step responses with and without RISO Dual Feedback circuit with the component values in Table 7-4.

Table 7-4. INA791x-Q1 RISO Dual Feedback Values

Adjustable Gain	Total Gain (mV/A)	R _{FB1}	R _{FB2}	R _{ISO}	C _F	Min C _L
1	20	19.1kΩ	Open	200Ω	10nF	10nF
2	40	19.1kΩ	19.1kΩ	0Ω (Short)	0.1nF	Open
3	60	19.1kΩ	9.76kΩ	0Ω (Short)	0.1nF	Open
4	80	19.1kΩ	6.26kΩ	0Ω (Short)	0.1nF	Open

Table 7-4. INA791x-Q1 RISO Dual Feedback Values (continued)

Adjustable Gain	Total Gain (mV/A)	R _{FB1}	R _{FB2}	R _{ISO}	C _F	Min C _L
5	100	19.1kΩ	4.7kΩ	0Ω (Short)	0.1nF	Open

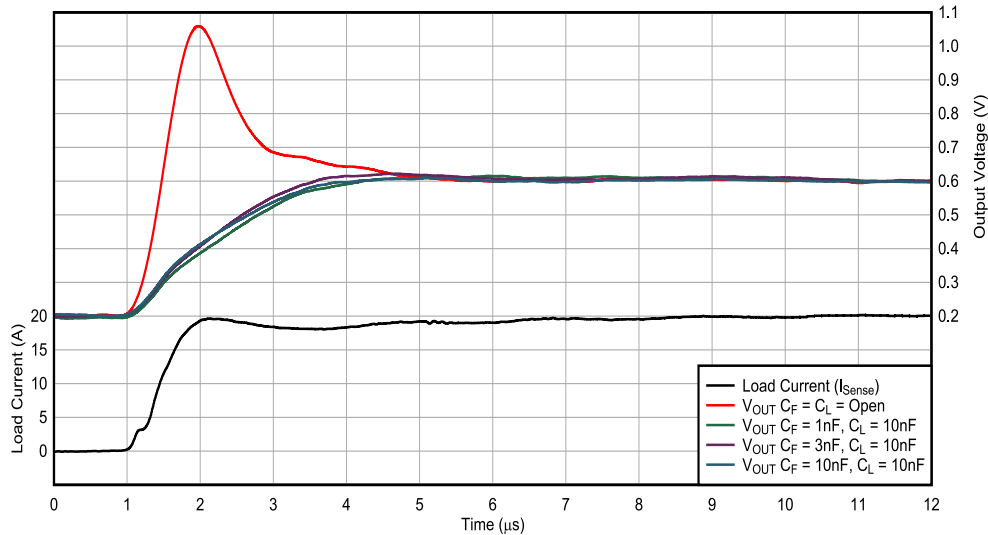

Adjustable Gain = 1, V_{CM} = 20V, V_S = 5V, V_{REF} = 0.2V

Figure 7-6. INA791x-Q1 Load Step Responses Before and After RISO Dual Feedback for Adjustable Gain of 1

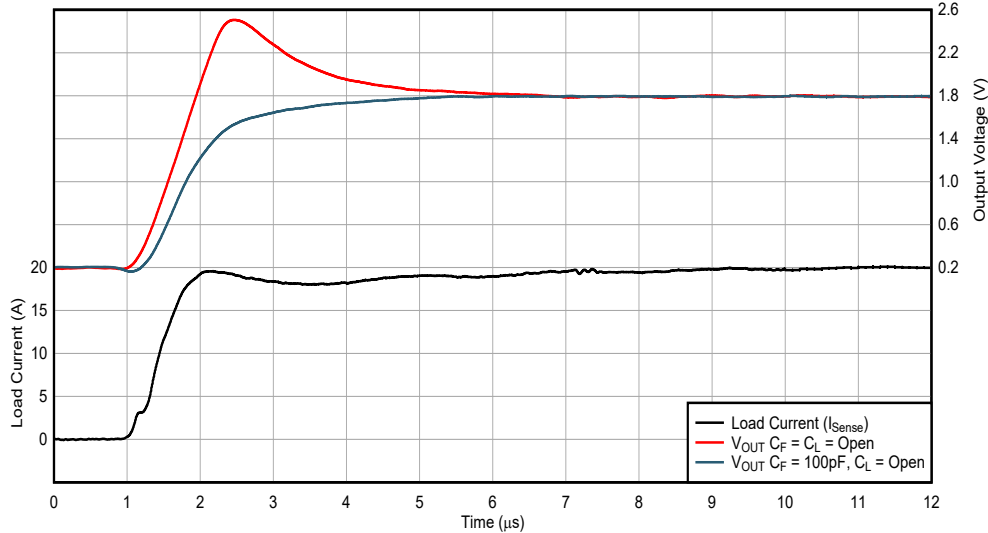

Adjustable Gain = 4, V_{CM} = 20V, V_S = 5V, V_{REF} = 0.2V

Figure 7-7. INA791x-Q1 Load Step Responses Before and After Feedback Capacitor For Adjustable Gain of 4

7.2 Typical Applications

The INA791x-Q1 offers advantages for multiple applications including the following:

- High common-mode range and excellent CMRR enables direct inline sensing

- Precision low-inductive, low-drift shunt eliminates the need for overtemperature system calibration
- Ultra-low offset and drift eliminates the necessity of calibration
- Wide supply range enables a direct interface with most microprocessors

7.2.1 High-Side, High-Drive, Solenoid Current-Sense Application

Challenges exist in solenoid drive current sensing that are similar to those in motor inline current sensing. In certain topologies, the current-sensing amplifier is exposed to the full-scale PWM voltage between ground and supply. The INA791x-Q1 is an excellent choice for this type of application. The 400μΩ integrated shunt with a total system accuracy of 0.35% with a total system drift of 35ppm/°C provides system accuracy across temperature eliminating the need for system calibration at multiple temperatures.

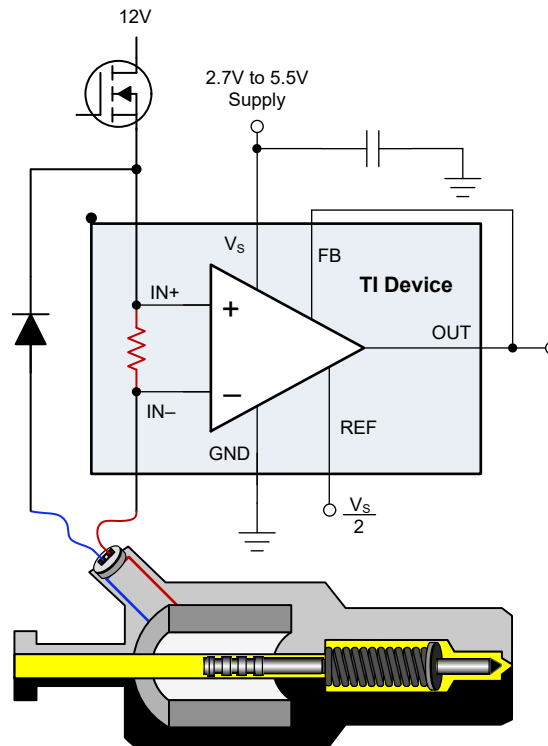

Figure 7-8. Solenoid Drive Application Circuit

7.2.1.1 Design Requirements

For this application, the INA791x-Q1 measures current in the driver circuit of a 12V, 1A hydraulic valve.

Table 7-5. Design Parameters

DESIGN PARAMETER	EXAMPLE VALUE
Common-mode voltage	12V
Maximum sense current	1A
Power-supply voltage	5V

7.2.1.2 Detailed Design Procedure

To demonstrate the performance of the device, the INA791x-Q1, with total gain of 100mV/A (Adjustable Gain =5), is selected for this design and powered from a 5V supply.

Using the information in the [Reference Pin Connections for Bidirectional Current Measurements](#) section, the reference point is set to midscale by splitting the supply at mid point and connecting the REF.

7.2.1.3 Application Curve

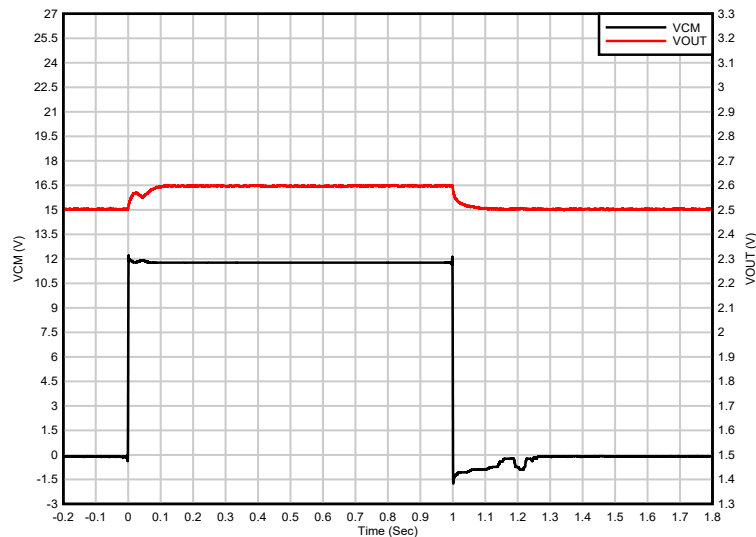

Figure 7-9. Solenoid Drive Current Sense Input and Output Signals

7.3 Power Supply Recommendations

The INA791x-Q1 makes accurate measurements beyond the connected power-supply voltage (VS) because the inputs (IN+ and IN-) operate anywhere between -4V and +110V, independent of VS. For example, the VS power supply equals 5V and the common-mode voltage of the measured shunt can be as high as 110V. Although the common-mode voltage of the input can be beyond the supply voltage, the output voltage range of the INA791x-Q1 is constrained to the supply voltage.

Place the power-supply bypass capacitor as close as possible to the supply and ground pins. The recommended value of this bypass capacitor is 0.1 μ F. Additional decoupling capacitance can be added to compensate for noisy or high-impedance power supplies. If the INA791x-Q1 output is set to mid-supply, then take extreme care to minimize noise on the power supply.

7.4 Layout

7.4.1 Layout Guidelines

- This device is specified for current handling of up to 50A over the entire -40°C to +125°C temperature range using a 2oz copper pour for the input power plane, as well as no external airflow passing over the device.
- The primary current-handling limitation for this device is how much heat is dissipated inside the package. Efforts to improve heat transfer out of the package and into the surrounding environment improve the ability of the device to handle currents of up to 50A over a wider temperature range.
- Heat transfer improvements primarily involve larger copper power traces and planes with increased copper thickness (2oz.), as well as providing airflow to pass over the device. Thermal vias help spread the current and power dissipated over multiple board layers. The INA791x-Q1 evaluation module (EVM) features a 2oz copper pour for the planes, and is capable of supporting 50A at temperatures up to 125°C.
- The bypass capacitor must be placed close to device ground and supply pins, but can be moved farther out if needed to avoid cutting thermal planes. The recommended value of this bypass capacitor is 0.1 μ F. Additional decoupling capacitance can be added to compensate for noisy or high-impedance power supplies.

7.4.2 Layout Example

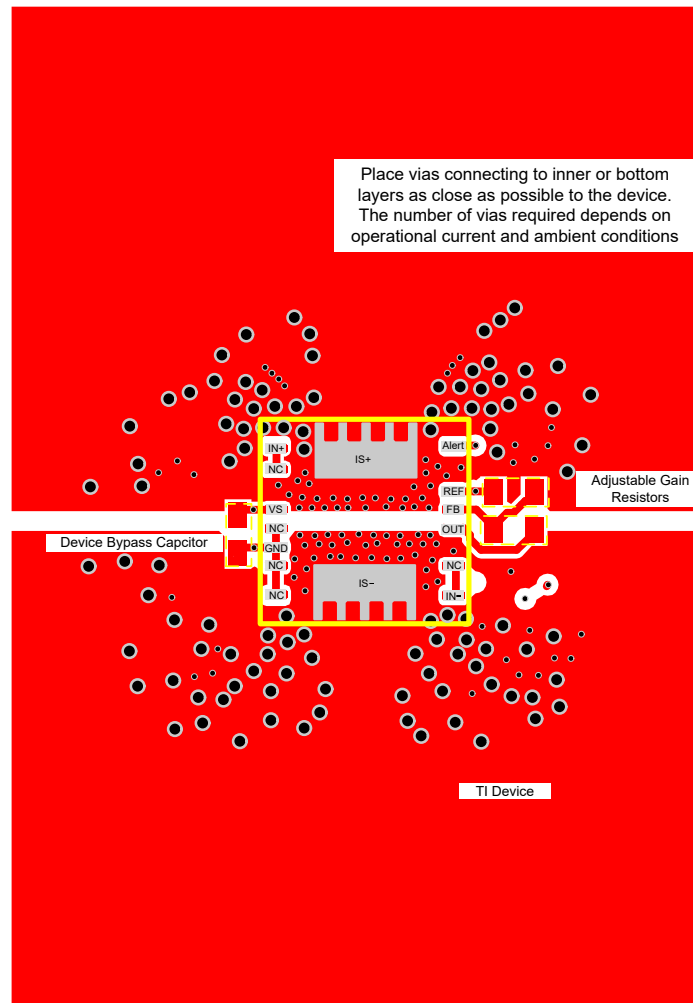

Figure 7-10. INA791x-Q1 Layout Example

8 Device and Documentation Support

8.1 Documentation Support

8.1.1 Related Documentation

For related documentation, see the following:

- Texas Instruments, [INA79xEVM](#), EVM User's Guide

8.2 Receiving Notification of Documentation Updates

To receive notification of documentation updates, navigate to the device product folder on [ti.com](#). Click on *Notifications* to register and receive a weekly digest of any product information that has changed. For change details, review the revision history included in any revised document.

8.3 Support Resources

[TI E2E™ support forums](#) are an engineer's go-to source for fast, verified answers and design help — straight from the experts. Search existing answers or ask your own question to get the quick design help you need.

Linked content is provided "AS IS" by the respective contributors. They do not constitute TI specifications and do not necessarily reflect TI's views; see TI's [Terms of Use](#).

8.4 Trademarks

EZShunt™ and TI E2E™ are trademarks of Texas Instruments. All trademarks are the property of their respective owners.

8.5 Electrostatic Discharge Caution



This integrated circuit can be damaged by ESD. Texas Instruments recommends that all integrated circuits be handled with appropriate precautions. Failure to observe proper handling and installation procedures can cause damage.

ESD damage can range from subtle performance degradation to complete device failure. Precision integrated circuits may be more susceptible to damage because very small parametric changes could cause the device not to meet its published specifications.

8.6 Glossary

[TI Glossary](#) This glossary lists and explains terms, acronyms, and definitions.

9 Revision History

NOTE: Page numbers for previous revisions may differ from page numbers in the current version.

DATE	REVISION	NOTES
January 2026	*	Initial Release

10 Mechanical, Packaging, and Orderable Information

The following pages include mechanical, packaging, and orderable information. This information is the most-current data available for the designated devices. This data is subject to change without notice and without revision of this document. For browser-based versions of this data sheet, see the left-hand navigation pane.

PACKAGING INFORMATION

Orderable part number	Status (1)	Material type (2)	Package Pins	Package qty Carrier	RoHS (3)	Lead finish/ Ball material (4)	MSL rating/ Peak reflow (5)	Op temp (°C)	Part marking (6)
INA791AQWDEKRQ1	Active	Production	null (null)	4000 LARGE T&R	Yes	NIPDAU	Level-1-260C-UNLIM	-40 to 125	INA 791AQ1
INA791BQWDEKRQ1	Active	Production	null (null)	4000 LARGE T&R	Yes	NIPDAU	Level-1-260C-UNLIM	-40 to 125	INA 791BQ1

(1) **Status:** For more details on status, see our [product life cycle](#).

(2) **Material type:** When designated, preproduction parts are prototypes/experimental devices, and are not yet approved or released for full production. Testing and final process, including without limitation quality assurance, reliability performance testing, and/or process qualification, may not yet be complete, and this item is subject to further changes or possible discontinuation. If available for ordering, purchases will be subject to an additional waiver at checkout, and are intended for early internal evaluation purposes only. These items are sold without warranties of any kind.

(3) **RoHS values:** Yes, No, RoHS Exempt. See the [TI RoHS Statement](#) for additional information and value definition.

(4) **Lead finish/Ball material:** Parts may have multiple material finish options. Finish options are separated by a vertical ruled line. Lead finish/Ball material values may wrap to two lines if the finish value exceeds the maximum column width.

(5) **MSL rating/Peak reflow:** The moisture sensitivity level ratings and peak solder (reflow) temperatures. In the event that a part has multiple moisture sensitivity ratings, only the lowest level per JEDEC standards is shown. Refer to the shipping label for the actual reflow temperature that will be used to mount the part to the printed circuit board.

(6) **Part marking:** There may be an additional marking, which relates to the logo, the lot trace code information, or the environmental category of the part.

Multiple part markings will be inside parentheses. Only one part marking contained in parentheses and separated by a "-" will appear on a part. If a line is indented then it is a continuation of the previous line and the two combined represent the entire part marking for that device.

Important Information and Disclaimer: The information provided on this page represents TI's knowledge and belief as of the date that it is provided. TI bases its knowledge and belief on information provided by third parties, and makes no representation or warranty as to the accuracy of such information. Efforts are underway to better integrate information from third parties. TI has taken and continues to take reasonable steps to provide representative and accurate information but may not have conducted destructive testing or chemical analysis on incoming materials and chemicals. TI and TI suppliers consider certain information to be proprietary, and thus CAS numbers and other limited information may not be available for release.

In no event shall TI's liability arising out of such information exceed the total purchase price of the TI part(s) at issue in this document sold by TI to Customer on an annual basis.

OTHER QUALIFIED VERSIONS OF INA791A-Q1 :

- Catalog : [INA791A](#)

NOTE: Qualified Version Definitions:

- Catalog - TI's standard catalog product

IMPORTANT NOTICE AND DISCLAIMER

TI PROVIDES TECHNICAL AND RELIABILITY DATA (INCLUDING DATASHEETS), DESIGN RESOURCES (INCLUDING REFERENCE DESIGNS), APPLICATION OR OTHER DESIGN ADVICE, WEB TOOLS, SAFETY INFORMATION, AND OTHER RESOURCES "AS IS" AND WITH ALL FAULTS, AND DISCLAIMS ALL WARRANTIES, EXPRESS AND IMPLIED, INCLUDING WITHOUT LIMITATION ANY IMPLIED WARRANTIES OF MERCHANTABILITY, FITNESS FOR A PARTICULAR PURPOSE OR NON-INFRINGEMENT OF THIRD PARTY INTELLECTUAL PROPERTY RIGHTS.

These resources are intended for skilled developers designing with TI products. You are solely responsible for (1) selecting the appropriate TI products for your application, (2) designing, validating and testing your application, and (3) ensuring your application meets applicable standards, and any other safety, security, regulatory or other requirements.

These resources are subject to change without notice. TI grants you permission to use these resources only for development of an application that uses the TI products described in the resource. Other reproduction and display of these resources is prohibited. No license is granted to any other TI intellectual property right or to any third party intellectual property right. TI disclaims responsibility for, and you fully indemnify TI and its representatives against any claims, damages, costs, losses, and liabilities arising out of your use of these resources.

TI's products are provided subject to [TI's Terms of Sale](#), [TI's General Quality Guidelines](#), or other applicable terms available either on [ti.com](#) or provided in conjunction with such TI products. TI's provision of these resources does not expand or otherwise alter TI's applicable warranties or warranty disclaimers for TI products. Unless TI explicitly designates a product as custom or customer-specified, TI products are standard, catalog, general purpose devices.

TI objects to and rejects any additional or different terms you may propose.

Copyright © 2026, Texas Instruments Incorporated

Last updated 10/2025