

## ESD851 36V Bidirectional ESD Protection Diode in SOD-323

### 1 Features

- IEC 61000-4-2 ESD protection:
  - $\pm 30\text{kV}$  contact discharge
  - $\pm 30\text{kV}$  air gap discharge
- IEC 61000-4-5 surge protection:
  - 6.5A (8/20 $\mu\text{s}$ )
  - Clamping voltage: 71V at 6.5A (8/20 $\mu\text{s}$ )
- IO Capacitance: 4.3pF (typical)
- DC breakdown voltage: 37.8V (minimum)
- Ultra low leakage current: 10nA (maximum)
- ESD clamping voltage: 56V at 16A TLP
- Industrial temperature range:  $-55^{\circ}\text{C}$  to  $+150^{\circ}\text{C}$
- Industry standard SOD-323 leaded package (2.5mm  $\times$  1.2mm)

### 2 Applications

- I/O Protection
- [Medical & Healthcare](#)
- [Appliances](#)
- [Lighting](#)
- [Test & Measurement](#)

### 3 Description

The ESD851 is a bidirectional ESD protection diode designed for clamping harmful transients such as ESD and surge. The ESD851 is rated to dissipate ESD strikes up to  $\pm 30\text{kV}$  (contact and air gap discharge), which exceeds the maximum level specified in the IEC 61000-4-2 international standard (Level 4). For surges, the device can clamp 8/20 $\mu\text{s}$  surges with peak currents up to 6.5A in accordance with the IEC 61000-4-5 standard.

This device also features a 4.3pF (typical) IO capacitance enabling it to protect data lines. The low dynamic resistance and low clamping voltage provides system level protection against transient events.

The ESD851 is offered in the industry standard, leaded SOD-323 package to enable easy solderability.

#### Package Information

PART NUMBER	PACKAGE <sup>(1)</sup>	PACKAGE SIZE <sup>(2)</sup>
ESD851	DYF (SOD-323, 2)	2.65mm $\times$ 1.3mm

- (1) For more information, see [Section 9](#).
- (2) The package size (length  $\times$  width) is a nominal value and includes pins, where applicable.

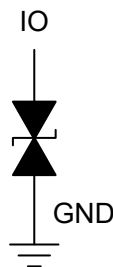

**Functional Block Diagram**



## Table of Contents

<b>1 Features</b> .....	1	6.1 Application Information.....	7
<b>2 Applications</b> .....	1	<b>7 Device and Documentation Support</b> .....	7
<b>3 Description</b> .....	1	7.1 Documentation Support.....	7
<b>4 Pin Configuration and Functions</b> .....	3	7.2 Receiving Notification of Documentation Updates.....	7
<b>5 Specifications</b> .....	4	7.3 Support Resources.....	7
5.1 Absolute Maximum Ratings.....	4	7.4 Trademarks.....	7
5.2 ESD Ratings—JEDEC Specification.....	4	7.5 Electrostatic Discharge Caution.....	7
5.3 ESD Ratings—IEC Specification.....	4	7.6 Glossary.....	7
5.4 Recommended Operating Conditions.....	4	<b>8 Revision History</b> .....	8
5.5 Thermal Information.....	5	<b>9 Mechanical, Packaging, and Orderable Information</b> ....	8
5.6 Electrical Characteristics.....	5	9.1 Tape and Reel Information.....	8
5.7 Typical Characteristics.....	6	9.2 Mechanical Data.....	10
<b>6 Application and Implementation</b> .....	7		

## 4 Pin Configuration and Functions

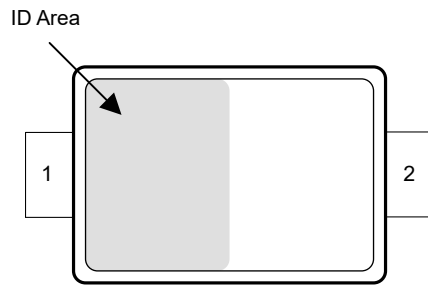

**Figure 4-1. DYF Package, 2-Pin SOD-323 (Top View)**

**Table 4-1. Pin Functions**

PIN		TYPE <sup>(1)</sup>	DESCRIPTION
NO.	NAME		
1	IO	I/O	Protected Channel. If used as IO, connect pin 2 to ground
2	IO	I/O	Protected Channel. If used as IO, connect pin 1 to ground

(1) I = input, O = output. GND = ground

## 5 Specifications

### 5.1 Absolute Maximum Ratings

over operating free-air temperature range (unless otherwise noted) <sup>(1)</sup>

Parameter		MIN	MAX	UNIT
$P_{PP}$ <sup>(2)</sup> <sup>(3)</sup>	IEC 61000-4-5 ( $t_p$ 8/20 $\mu$ s) Peak Pulse Power at 25°C		400	W
$I_{PP}$	IEC 61000-4-5 ( $t_p$ 8/20 $\mu$ s) Peak Pulse Current at 25°C		6.5	A
$T_A$	Ambient Operating Temperature	-55	150	°C
$T_{stg}$	Storage Temperature	-65	155	°C

- (1) Operation outside the Absolute Maximum Ratings may cause permanent device damage. Absolute maximum ratings do not imply functional operation of the device at these or any other conditions beyond those listed under Recommended Operating Conditions. If briefly operating outside the Recommended Operating Conditions but within the Absolute Maximum Ratings, the device may not sustain damage, but it may not be fully functional. Operating the device in this manner may affect device reliability, functionality, performance, and shorten the device lifetime.
- (2) Voltages are with respect to GND unless otherwise noted.
- (3) Measured at 25°C

### 5.2 ESD Ratings—JEDEC Specification

			VALUE	UNIT
$V_{(ESD)}$	Electrostatic discharge	Human body model (HBM), per ANSI/ESDA/JEDEC JS-001 <sup>(1)</sup>	±2500	V
		Charged device model (CDM), per JEDEC specification JS-002 <sup>(2)</sup>	±1000	V

- (1) JEDEC document JEP155 states that 500V HBM allows safe manufacturing with a standard ESD control process
- (2) JEDEC document JEP157 states that 250V CDM allows safe manufacturing with a standard ESD control process.

### 5.3 ESD Ratings—IEC Specification

			VALUE	UNIT
$V_{(ESD)}$	Electrostatic discharge	IEC 61000-4-2 contact discharge	±30000	V
		IEC 61000-4-2 air-gap discharge	±30000	

### 5.4 Recommended Operating Conditions

over operating free-air temperature range (unless otherwise noted)

		MIN	NOM	MAX	UNIT
$V_{IN}$	Input pin voltage	-36		36	V
$T_A$	Operating Free Air Temperature	-55		150	°C

## 5.5 Thermal Information

THERMAL METRIC <sup>(1)</sup>		ESD851	UNIT
		DYF (SOD-323)	
		2 PINS	
$R_{\theta JA}$	Junction-to-ambient thermal resistance	686.1	°C/W
$R_{\theta JC(top)}$	Junction-to-case (top) thermal resistance	267.0	°C/W
$R_{\theta JB}$	Junction-to-board thermal resistance	560.5	°C/W
$\Psi_{JT}$	Junction-to-top characterization parameter	91.4	°C/W
$\Psi_{JB}$	Junction-to-board characterization parameter	546.2	°C/W
$R_{\theta JC(bot)}$	Junction-to-case (bottom) thermal resistance	N/A	°C/W

(1) For more information about traditional and new thermal metrics, see the [Semiconductor and IC Package Thermal Metrics](#) application report.

## 5.6 Electrical Characteristics

At  $T_A=25^\circ\text{C}$  (unless otherwise noted) <sup>(1)</sup>

PARAMETER		TEST CONDITION	MIN	TYP	MAX	UNIT
$V_{RWM}$	Reverse stand-off voltage	$I_{IO} < 50\text{nA}$ , across operating temperature range			36	V
$V_{BR}$	Breakdown voltage	$I_{IO} = 10\text{mA}$ , I/O to GND or GND to I/O	37.8	41.2	44.2	V
$I_{LEAK}$	Reverse leakage current	$V_{IO} = 36\text{V}$ , IO to GND or GND to IO		5	10	nA
$V_{CLAMP}$	Surge clamping voltage, $t_p = 8/20\mu\text{s}$ <sup>(2)</sup>	$I_{PP} = 1\text{A}$ , IO to GND or GND to IO			47	V
		$I_{PP} = 5\text{A}$ , IO to GND or GND to IO			64	V
		$I_{PP} = 6.5\text{A}$ , IO to GND or GND to IO			71	V
	TLP clamping voltage, $t_p = 100\text{ns}$	$I_{PP} = 16\text{A}$ , IO to GND or GND to IO		56		V
$R_{DYN}$	Dynamic resistance <sup>(3)</sup>	IO to GND		0.6		$\Omega$
		GND to IO				
$C_L$	Line capacitance	$V_{IO} = 0\text{V}$ ; $f = 1\text{MHz}$ , IO to GND		4.3	6	pF

(1) Typical parameters are measured at  $25^\circ\text{C}$

(2) Nonrepetitive current pulse 8 to  $20\mu\text{s}$  exponentially decaying waveform according to IEC 61000-4-5

(3) Extraction of  $R_{DYN}$  using least squares fit of TLP characteristics between  $I = 10\text{A}$  and  $I = 20\text{A}$

## 5.7 Typical Characteristics

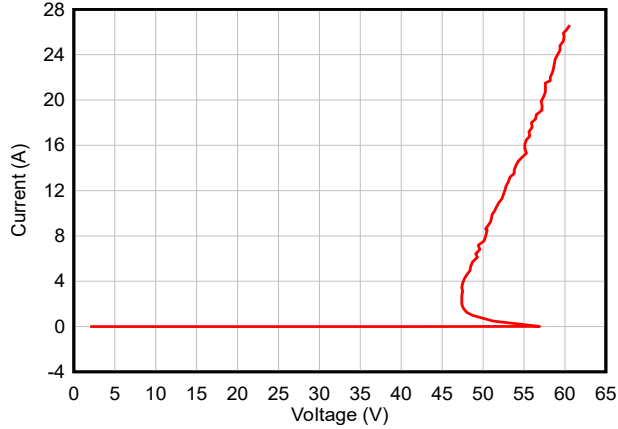

Figure 5-1. Positive TLP Curve

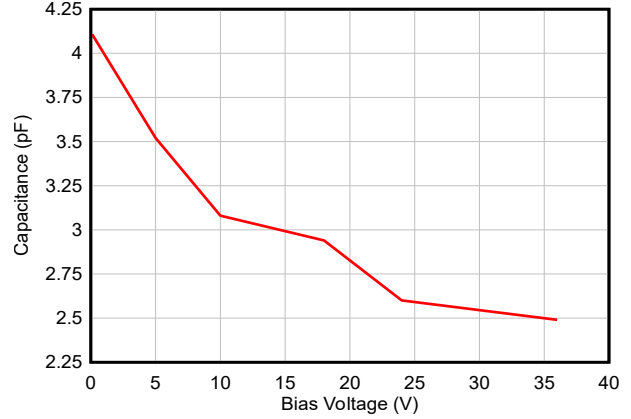

Figure 5-2. Capacitance vs Bias Voltage

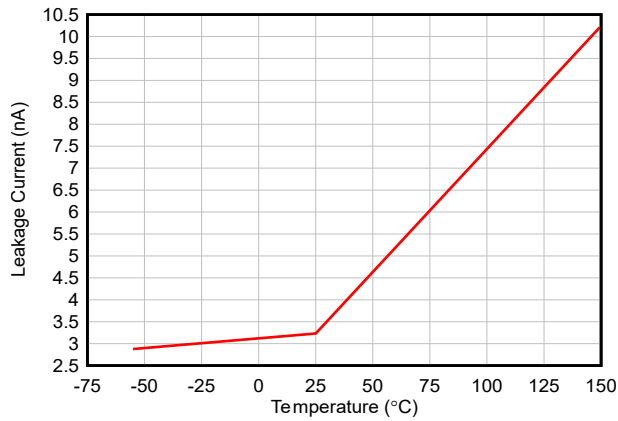

Figure 5-3. Leakage Current vs Temperature

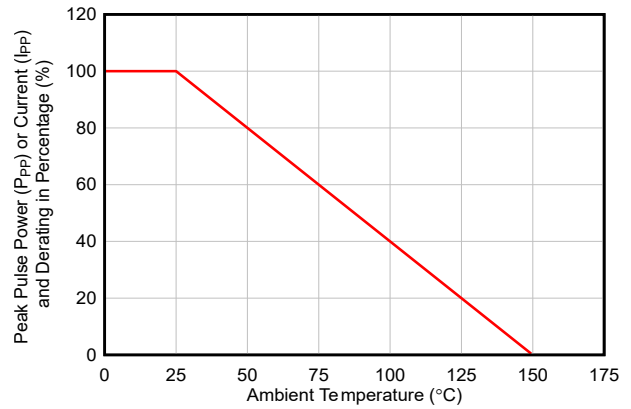

Figure 5-4. Peak Pulse Power Derating Curve

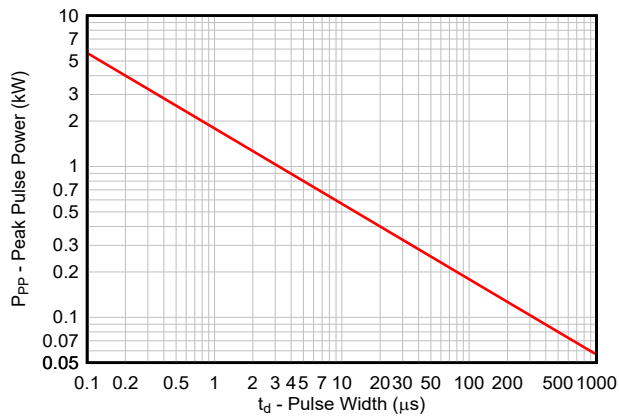

Figure 5-5. Pulse Power Rating Curve

## 6 Application and Implementation

### Note

Information in the following applications sections is not part of the TI component specification, and TI does not warrant its accuracy or completeness. TI's customers are responsible for determining suitability of components for their purposes, as well as validating and testing their design implementation to confirm system functionality.

### 6.1 Application Information

The ESD851 is a diode type TVS which provides a path to ground for dissipating transient voltage spikes, such as ESD or surge, on signal lines and power lines. Connect the device in parallel to the down stream circuitry for protection. As the current from the transient passes through the TVS, only a small voltage drop is present across the diode. This is the voltage presented to the protected IC. The low  $R_{DYN}$  of the triggered TVS holds this voltage ( $V_{CLAMP}$ ) to a safe level for the protected IC. For more information on how to properly use this device, refer to the [ESD Packaging and Layout Guide](#) for more details.

## 7 Device and Documentation Support

### 7.1 Documentation Support

#### 7.1.1 Related Documentation

For related documentation, see the following:

- Texas Instruments, [ESD Layout Guide application reports](#)
- Texas Instruments, [Generic ESD Evaluation Module user's guide](#)
- Texas Instruments, [Picking ESD Diodes for Ultra High-Speed Data Lines application reports](#)
- Texas Instruments, [Reading and Understanding an ESD Protection data sheet](#)

### 7.2 Receiving Notification of Documentation Updates

To receive notification of documentation updates, navigate to the device product folder on [ti.com](#). Click on [Notifications](#) to register and receive a weekly digest of any product information that has changed. For change details, review the revision history included in any revised document.

### 7.3 Support Resources

[TI E2E™ support forums](#) are an engineer's go-to source for fast, verified answers and design help — straight from the experts. Search existing answers or ask your own question to get the quick design help you need.

Linked content is provided "AS IS" by the respective contributors. They do not constitute TI specifications and do not necessarily reflect TI's views; see TI's [Terms of Use](#).

### 7.4 Trademarks

TI E2E™ is a trademark of Texas Instruments.

All trademarks are the property of their respective owners.

### 7.5 Electrostatic Discharge Caution



This integrated circuit can be damaged by ESD. Texas Instruments recommends that all integrated circuits be handled with appropriate precautions. Failure to observe proper handling and installation procedures can cause damage.

ESD damage can range from subtle performance degradation to complete device failure. Precision integrated circuits may be more susceptible to damage because very small parametric changes could cause the device not to meet its published specifications.

### 7.6 Glossary

[TI Glossary](#) This glossary lists and explains terms, acronyms, and definitions.

## 8 Revision History

DATE	REVISION	NOTES
August 2024	*	Initial Release

## 9 Mechanical, Packaging, and Orderable Information

The following pages include mechanical, packaging, and orderable information. This information is the most current data available for the designated devices. This data is subject to change without notice and revision of this document. For browser-based versions of this data sheet, refer to the left-hand navigation.

### 9.1 Tape and Reel Information

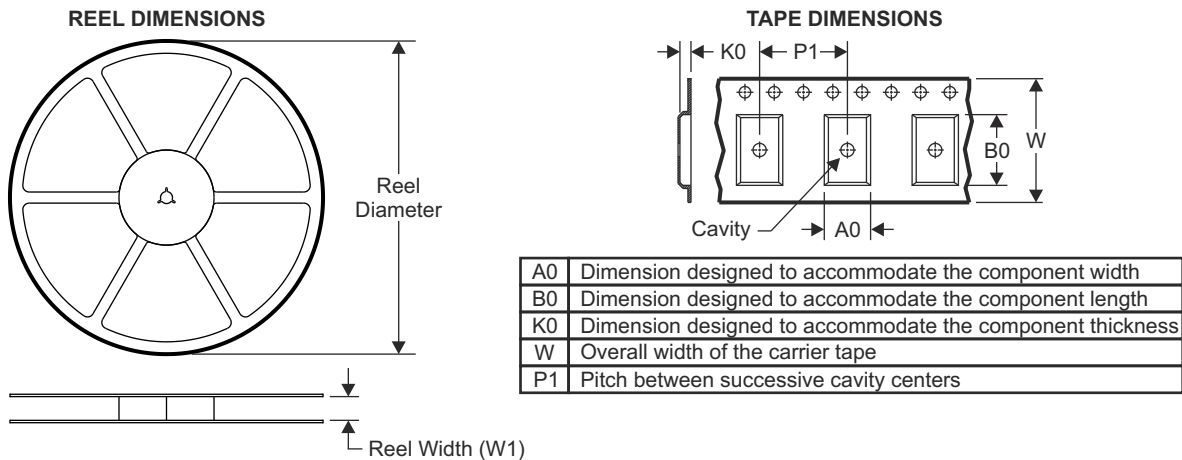

#### QUADRANT ASSIGNMENTS FOR PIN 1 ORIENTATION IN TAPE

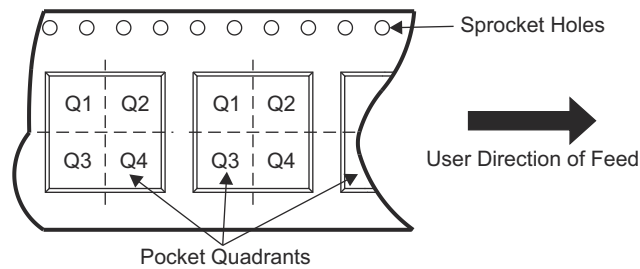

Device	Package Type	Package Drawing	Pins	SPQ	Reel Diameter (mm)	Reel Width W1 (mm)	A0 (mm)	B0 (mm)	K0 (mm)	P1 (mm)	W (mm)	Pin1 Quadrant
ESD851	LARGE T&R	DYF	2	3000	178.000	9.500	1.480	3.300	1.250	4.000	8.000	Q1



**TAPE AND REEL BOX DIMENSIONS**



Device	Package Type	Package Drawing	Pins	SPQ	Length (mm)	Width (mm)	Height (mm)
ESD851	LARGE T&R	DYF	2	3000	210.000	200.000	42.000

## 9.2 Mechanical Data



**DYF0002A**

**PACKAGE OUTLINE**  
**SOT(SOD-323) - 1 mm max height**

SMALL OUTLINE TRANSISTOR

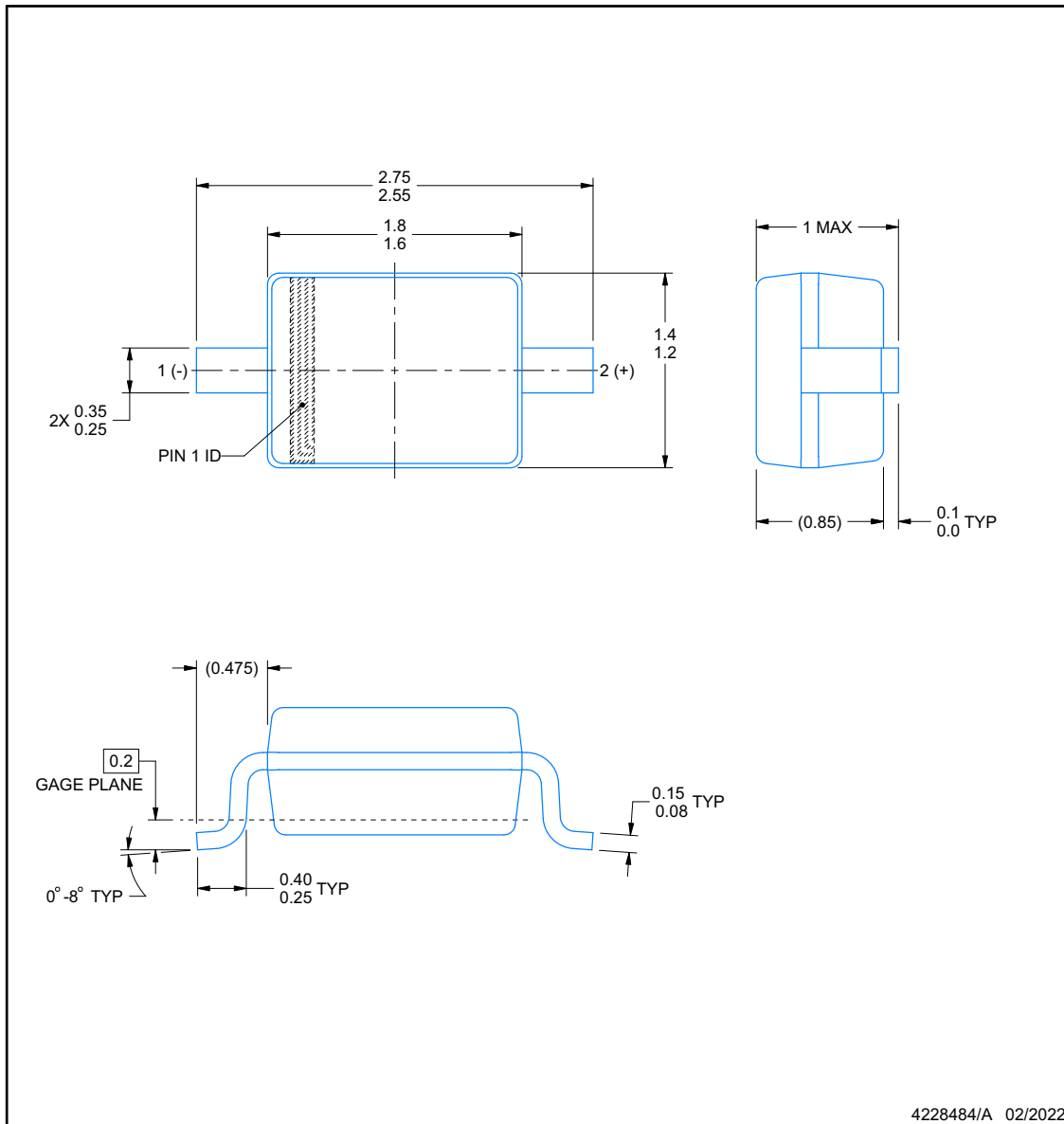

NOTES:

1. All linear dimensions are in millimeters. Any dimensions in parenthesis are for reference only. Dimensioning and tolerancing per ASME Y14.5M.
2. This drawing is subject to change without notice.

## EXAMPLE BOARD LAYOUT

**DYF0002A**

**SOT(SOD-323) - 1 mm max height**

SMALL OUTLINE TRANSISTOR

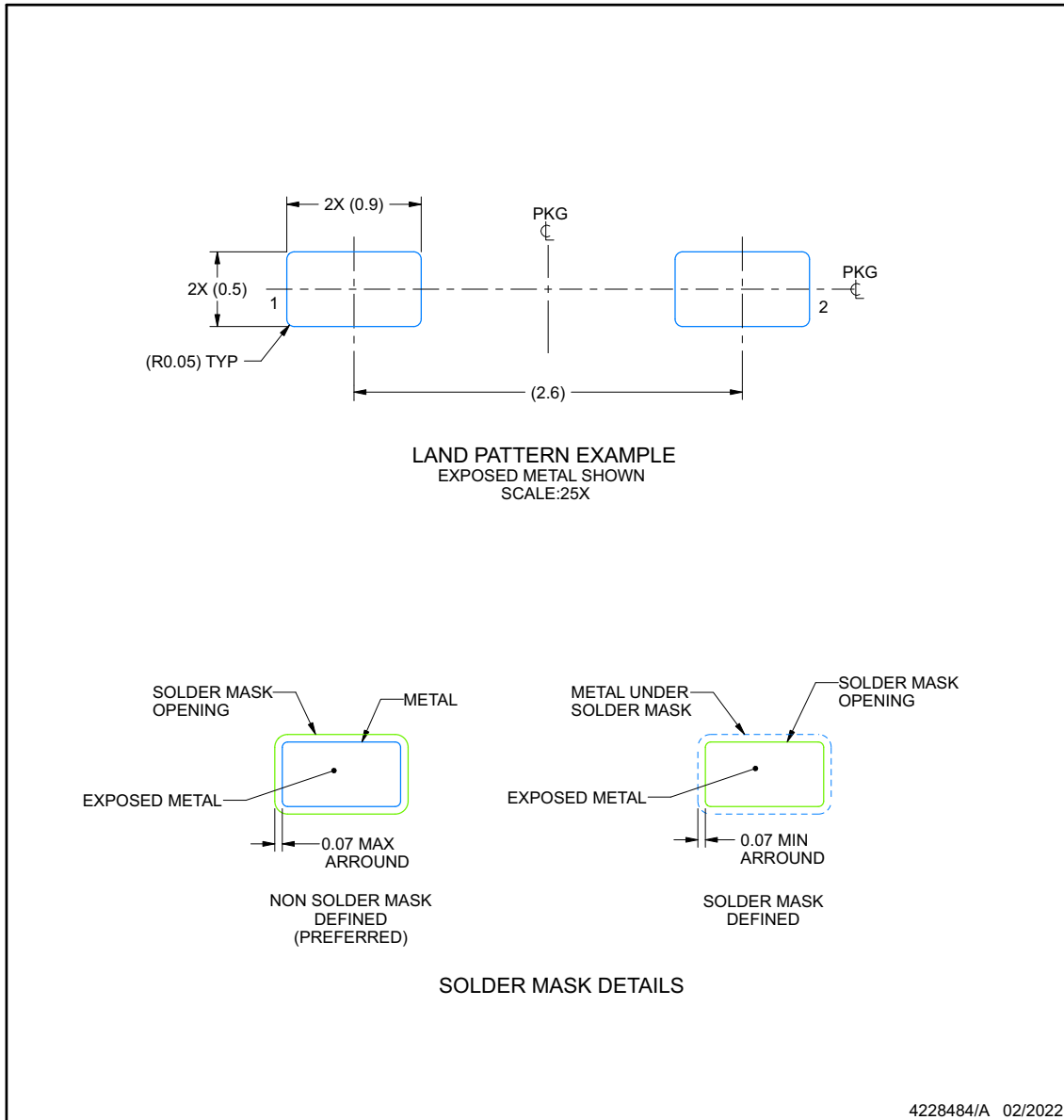

NOTES: (continued)

3. Publication IPC-7351 may have alternate designs.
4. Solder mask tolerances between and around signal pads can vary based on board fabrication site.

## EXAMPLE STENCIL DESIGN

**DYF0002A**

**SOT(SOD-323) - 1 mm max height**

SMALL OUTLINE TRANSISTOR

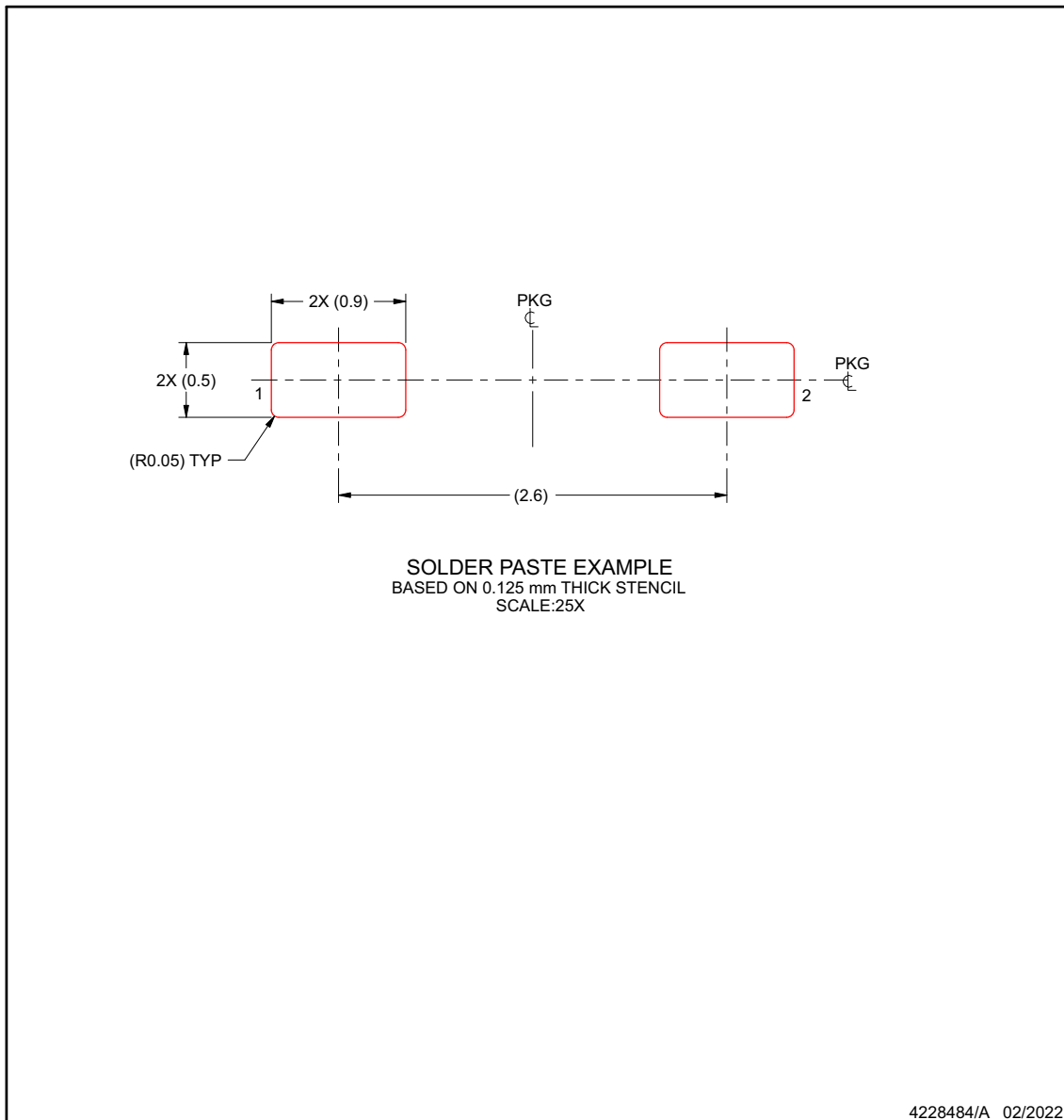

NOTES: (continued)

5. Laser cutting apertures with trapezoidal walls and rounded corners may offer better paste release. IPC-7525 may have alternate design recommendations.
6. Board assembly site may have different recommendations for stencil design.

**PACKAGING INFORMATION**

Orderable part number	Status (1)	Material type (2)	Package   Pins	Package qty   Carrier	RoHS (3)	Lead finish/ Ball material (4)	MSL rating/ Peak reflow (5)	Op temp (°C)	Part marking (6)
<a href="#">ESD851DYFR</a>	Active	Production	SOT (DYF)   2	3000   LARGE T&R	Yes	SN	Level-3-260C-168 HR	-55 to 150	3H6F
ESD851DYFR.B	Active	Production	SOT (DYF)   2	3000   LARGE T&R	Yes	SN	Level-3-260C-168 HR	-55 to 150	3H6F

(1) **Status:** For more details on status, see our [product life cycle](#).

(2) **Material type:** When designated, preproduction parts are prototypes/experimental devices, and are not yet approved or released for full production. Testing and final process, including without limitation quality assurance, reliability performance testing, and/or process qualification, may not yet be complete, and this item is subject to further changes or possible discontinuation. If available for ordering, purchases will be subject to an additional waiver at checkout, and are intended for early internal evaluation purposes only. These items are sold without warranties of any kind.

(3) **RoHS values:** Yes, No, RoHS Exempt. See the [TI RoHS Statement](#) for additional information and value definition.

(4) **Lead finish/Ball material:** Parts may have multiple material finish options. Finish options are separated by a vertical ruled line. Lead finish/Ball material values may wrap to two lines if the finish value exceeds the maximum column width.

(5) **MSL rating/Peak reflow:** The moisture sensitivity level ratings and peak solder (reflow) temperatures. In the event that a part has multiple moisture sensitivity ratings, only the lowest level per JEDEC standards is shown. Refer to the shipping label for the actual reflow temperature that will be used to mount the part to the printed circuit board.

(6) **Part marking:** There may be an additional marking, which relates to the logo, the lot trace code information, or the environmental category of the part.

Multiple part markings will be inside parentheses. Only one part marking contained in parentheses and separated by a "-" will appear on a part. If a line is indented then it is a continuation of the previous line and the two combined represent the entire part marking for that device.

**Important Information and Disclaimer:**The information provided on this page represents TI's knowledge and belief as of the date that it is provided. TI bases its knowledge and belief on information provided by third parties, and makes no representation or warranty as to the accuracy of such information. Efforts are underway to better integrate information from third parties. TI has taken and continues to take reasonable steps to provide representative and accurate information but may not have conducted destructive testing or chemical analysis on incoming materials and chemicals. TI and TI suppliers consider certain information to be proprietary, and thus CAS numbers and other limited information may not be available for release.

In no event shall TI's liability arising out of such information exceed the total purchase price of the TI part(s) at issue in this document sold by TI to Customer on an annual basis.

**OTHER QUALIFIED VERSIONS OF ESD851 :**

- Automotive : [ESD851-Q1](#)

NOTE: Qualified Version Definitions:

- Automotive - Q100 devices qualified for high-reliability automotive applications targeting zero defects

DYF0002A



# PACKAGE OUTLINE

SOT(SOD-323) - 1 mm max height

SMALL OUTLINE TRANSISTOR

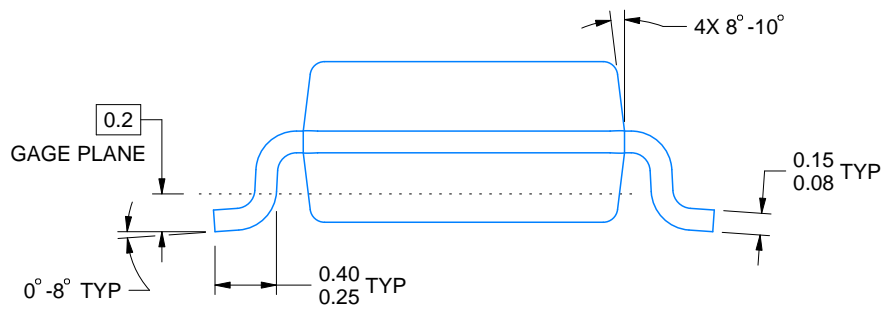
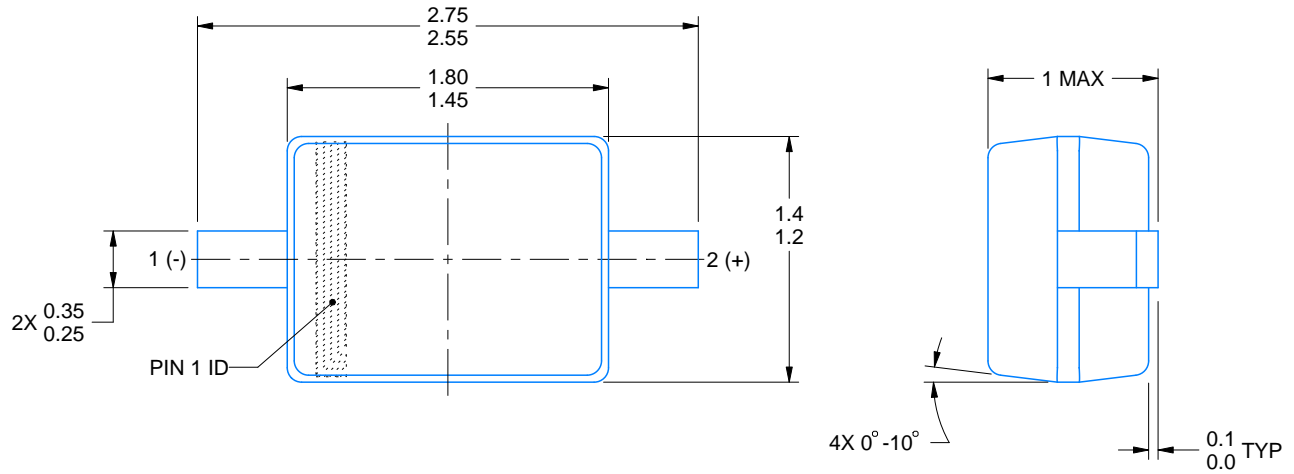

4228484/C 12/2024

## NOTES:

1. All linear dimensions are in millimeters. Any dimensions in parenthesis are for reference only. Dimensioning and tolerancing per ASME Y14.5M.
2. This drawing is subject to change without notice.

# EXAMPLE BOARD LAYOUT

DYF0002A

SOT(SOD-323) - 1 mm max height

SMALL OUTLINE TRANSISTOR

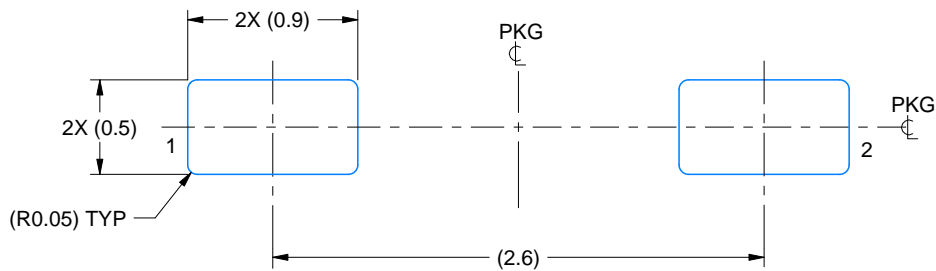

LAND PATTERN EXAMPLE  
EXPOSED METAL SHOWN  
SCALE:25X

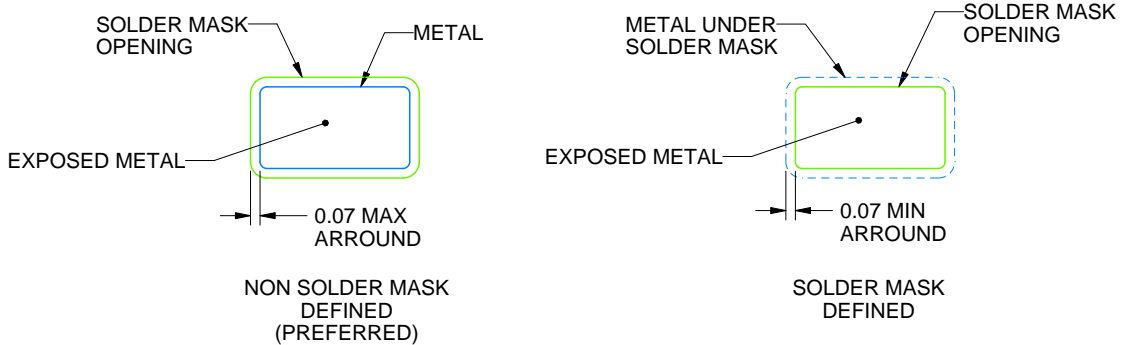

SOLDER MASK DETAILS

4228484/C 12/2024

NOTES: (continued)

- 3. Publication IPC-7351 may have alternate designs.
- 4. Solder mask tolerances between and around signal pads can vary based on board fabrication site.



# EXAMPLE STENCIL DESIGN

DYF0002A

SOT(SOD-323) - 1 mm max height

SMALL OUTLINE TRANSISTOR

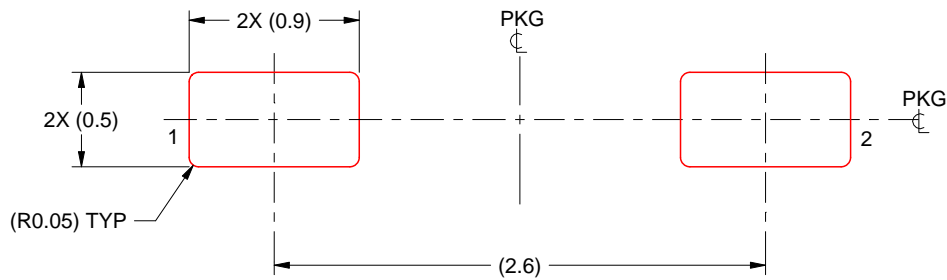

SOLDER PASTE EXAMPLE  
BASED ON 0.125 mm THICK STENCIL  
SCALE:25X

4228484/C 12/2024

NOTES: (continued)

5. Laser cutting apertures with trapezoidal walls and rounded corners may offer better paste release. IPC-7525 may have alternate design recommendations.
6. Board assembly site may have different recommendations for stencil design.

## IMPORTANT NOTICE AND DISCLAIMER

TI PROVIDES TECHNICAL AND RELIABILITY DATA (INCLUDING DATA SHEETS), DESIGN RESOURCES (INCLUDING REFERENCE DESIGNS), APPLICATION OR OTHER DESIGN ADVICE, WEB TOOLS, SAFETY INFORMATION, AND OTHER RESOURCES "AS IS" AND WITH ALL FAULTS, AND DISCLAIMS ALL WARRANTIES, EXPRESS AND IMPLIED, INCLUDING WITHOUT LIMITATION ANY IMPLIED WARRANTIES OF MERCHANTABILITY, FITNESS FOR A PARTICULAR PURPOSE OR NON-INFRINGEMENT OF THIRD PARTY INTELLECTUAL PROPERTY RIGHTS.

These resources are intended for skilled developers designing with TI products. You are solely responsible for (1) selecting the appropriate TI products for your application, (2) designing, validating and testing your application, and (3) ensuring your application meets applicable standards, and any other safety, security, regulatory or other requirements.

These resources are subject to change without notice. TI grants you permission to use these resources only for development of an application that uses the TI products described in the resource. Other reproduction and display of these resources is prohibited. No license is granted to any other TI intellectual property right or to any third party intellectual property right. TI disclaims responsibility for, and you will fully indemnify TI and its representatives against, any claims, damages, costs, losses, and liabilities arising out of your use of these resources.

TI's products are provided subject to [TI's Terms of Sale](#) or other applicable terms available either on [ti.com](https://www.ti.com) or provided in conjunction with such TI products. TI's provision of these resources does not expand or otherwise alter TI's applicable warranties or warranty disclaimers for TI products.

TI objects to and rejects any additional or different terms you may have proposed.

Mailing Address: Texas Instruments, Post Office Box 655303, Dallas, Texas 75265

Copyright © 2025, Texas Instruments Incorporated