

DRV8302 Three Phase Gate Driver With Dual Current Shunt Amplifiers and Buck Regulator – Hardware Controlled

1 Features

- 8-V to 60-V Operating Supply Voltage Range
- 1.7-A Source and 2.3-A Sink Gate Drive Current Capability
- Bootstrap Gate Driver With 100% Duty Cycle Support
- 6 or 3 PWM Input Modes
- Dual Integrated Current Shunt Amplifiers With Adjustable Gain and Offset
- 3.3-V and 5-V Interface Support
- Hardware Control Interface
- Protection Features:
 - Programmable Dead Time Control (DTC)
 - Programmable Overcurrent Protection (OCP)
 - PVDD and GVDD Undervoltage Lockout (UVLO)
 - GVDD Overvoltage Lockout (OVLO)
 - Overtemperature Warning/Shutdown (OTW/OTS)
 - Reported through nFAULT and nOCTW pins

2 Applications

- 3-Phase BLDC and PMSM Motors
- CPAP and Pumps
- E-Bikes
- Power Tools
- Robotics and RC Toys
- Industrial Automation

3 Description

The DRV8302 is a gate driver IC for three phase motor drive applications. It provides three half bridge drivers, each capable of driving two N-channel MOSFETs. The device supports up to 1.7-A source and 2.3-A peak current capability. The DRV8302 can operate off of a single power supply with a wide range from 8-V to 60-V. It uses a bootstrap gate driver architecture with trickle charge circuitry to support 100% duty cycle. The DRV8302 uses automatic hand shaking when the high side or low side MOSFET is switching to prevent current shoot through. Integrated VDS sensing of the high and low side MOSFETs is used to protect the external power stage against overcurrent conditions.

The DRV8303 includes two current shunt amplifiers for accurate current measurement. The amplifiers support bi-directional current sensing and provide and adjustable output offset up to 3 V.

The DRV8302 also includes an integrated switching mode buck converter with adjustable output and switching frequency. The buck converter can provide up to 1.5 A to support MCU or additional system power needs.

A hardware interface allows for configuring various device parameters including dead time, overcurrent, PWM mode, and amplifier settings. Error conditions are reported through the nFAULT and nOCTW pins.

Device Information⁽¹⁾

PART NUMBER	PACKAGE	BODY SIZE (NOM)
DRV8302	HTSSOP (56)	14.00 mm x 6.10 mm

(1) For all available packages, see the orderable addendum at the end of the data sheet.

Simplified Schematic

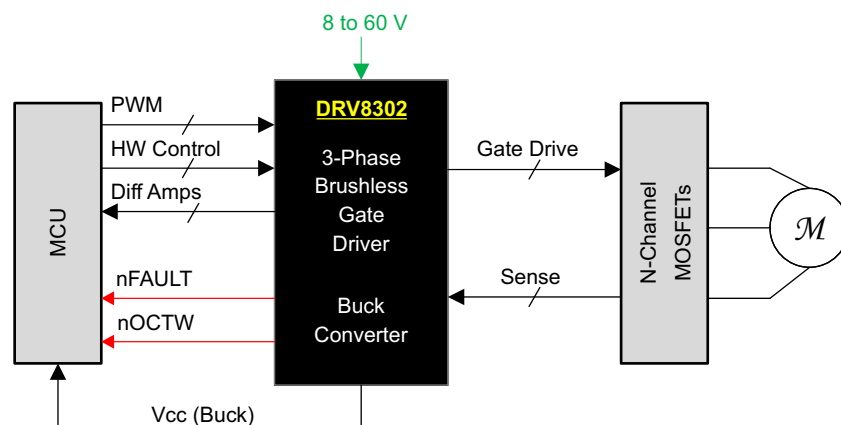

Table of Contents

1 Features	1	7.3 Feature Description	13
2 Applications	1	7.4 Device Functional Modes	19
3 Description	1	8 Application and Implementation	20
4 Revision History	2	8.1 Application Information	20
5 Pin Configuration and Functions	3	8.2 Typical Application	21
6 Specifications	5	9 Power Supply Recommendations	24
6.1 Absolute Maximum Ratings	5	9.1 Bulk Capacitance	24
6.2 ESD Ratings	5	10 Layout	25
6.3 Recommended Operating Conditions	6	10.1 Layout Guidelines	25
6.4 Thermal Information	6	10.2 Layout Example	25
6.5 Electrical Characteristics	7	11 Device and Documentation Support	26
6.6 Gate Timing and Protection Characteristics	8	11.1 Documentation Support	26
6.7 Current Shunt Amplifier Characteristics	8	11.2 Community Resources	26
6.8 Buck Converter Characteristics	9	11.3 Trademarks	26
6.9 Typical Characteristics	10	11.4 Electrostatic Discharge Caution	26
7 Detailed Description	11	11.5 Glossary	26
7.1 Overview	11	12 Mechanical, Packaging, and Orderable Information	26
7.2 Function Block Diagram	12		

4 Revision History

NOTE: Page numbers for previous revisions may differ from page numbers in the current version.

Changes from Revision B (February 2016) to Revision C	Page
• Deleted REG 0x02 from the test conditions of the I_{OSO1} and I_{OSI1} parameters in the <i>Electrical Characteristics</i> table	7
• Changed the value of $R1 + R2 \geq 100\text{ K}\Omega$ to $R1 + R2 \geq 1\text{ K}\Omega$ in the <i>OC_ADJ</i> section.	17

Changes from Revision A (December 2015) to Revision B	Page
• Changed VEN_BUCK in <i>Buck Converter Characteristics</i> From: MIN = 0.9 V and MAX = 1.55 V To: MIN = 1.11 V and MAX = 1.36 V.	9

Changes from Original (August 2011) to Revision A	Page
• Added <i>Pin Configuration and Functions</i> section, <i>ESD Rating</i> table, <i>Feature Description</i> section, <i>Device Functional Modes</i> , <i>Application and Implementation</i> section, <i>Power Supply Recommendations</i> section, <i>Layout</i> section, <i>Device and Documentation Support</i> section, and <i>Mechanical, Packaging, and Orderable Information</i> section	1
• V_{PVDD} absolute max voltage rating reduced from 70 V to 65 V	5
• Clarification made on how the OCP status bits report in <i>Overcurrent Protection (OCP) and Reporting</i>	16
• Update to PVDD1 undervoltage protection in <i>Undervoltage Protection (UVLO)</i> describing specific transient brownout issue.	17
• Update to EN_GATE pin functional description in <i>EN_GATE</i> clarifying proper EN_GATE reset pulse lengths.	19
• Added gate driver power-up sequencing errata <i>Gate Driver Power Up Sequencing Errata</i>	20
• Added <i>Community Resources</i>	24

5 Pin Configuration and Functions

DCA Package
56-Pin HTSSOP With PowerPAD™
Top View

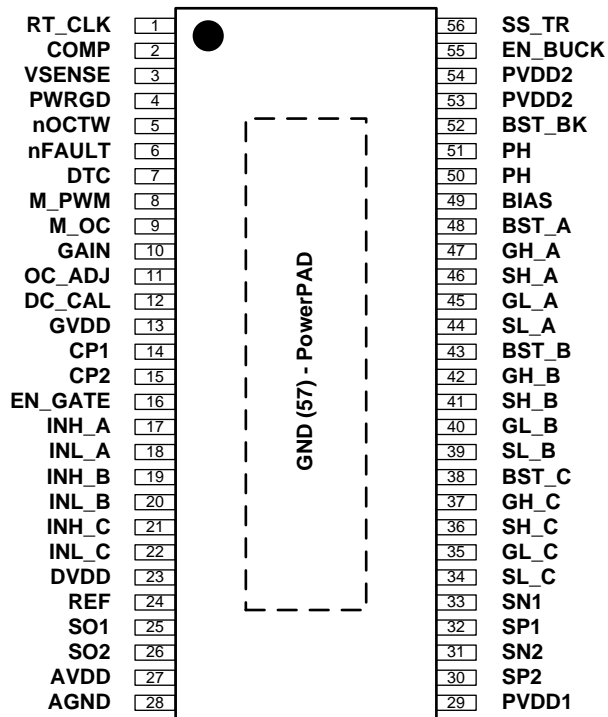

Pin Functions

PIN		I/O ⁽¹⁾	DESCRIPTION
NO.	NAME		
1	RT_CLK	I	Resistor timing and external clock for buck regulator. Resistor should connect to GND (PowerPAD™) with very short trace to reduce the potential clock jitter due to noise.
2	COMP	O	Buck error amplifier output and input to the output switch current comparator.
3	VSENSE	I	Buck output voltage sense pin. Inverting node of error amplifier.
4	PWRGD	I	An open drain output with external pullup resistor required. Asserts low if buck output voltage is low due to thermal shutdown, dropout, overvoltage, or EN_BUCK shut down
5	nOCTW	O	Overcurrent and overtemperature warning indicator. This output is open drain with external pullup resistor required.
6	nFAULT	O	Fault report indicator. This output is open drain with external pullup resistor required.
7	DTC	I	Dead-time adjustment with external resistor to GND
8	M_PWM	I	Mode selection pin for PWM input configuration. If M_PWM = LOW, the device supports 6 independent PWM inputs. When M_PWM = HIGH, the device must be connected to ONLY 3 PWM input signals on INH_x. The complementary PWM signals for low side signaling will be internally generated from the high side inputs.
9	M_OC	I	Mode selection pin for over-current protection options. If M_OC = LOW, the gate driver will operate in a cycle-by-cycle current limiting mode. If M_OC = HIGH, the gate driver will shutdown the channel which detected an over-current event.
10	GAIN	O	Gain selection for integrated current shunt amplifiers. If GAIN = LOW, the internal current shunt amplifiers have a gain of 10V/V. If GAIN = HIGH, the current shunt amplifiers have a gain of 40V/V.
11	OC_ADJ	I	Overcurrent trip set pin. Apply a voltage on this pin to set the trip point for the internal overcurrent protection circuitry. A voltage divider from DVDD is recommended.
12	DC_CAL	I	When DC_CAL is high, device shorts inputs of shunt amplifiers and disconnects loads. DC offset calibration can be done through external microcontroller.

(1) KEY: I = Input, O = Output, P = Power

Pin Functions (continued)

PIN		I/O ⁽¹⁾	DESCRIPTION
NO.	NAME		
13	GVDD	P	Internal gate driver voltage regulator. GVDD cap should connect to GND
14	CP1	P	Charge pump pin 1, ceramic cap should be used between CP1 and CP2
15	CP2	P	Charge pump pin 2, ceramic cap should be used between CP1 and CP2
16	EN_GATE	I	Enable gate driver and current shunt amplifiers. Control buck via EN_BUCK pin.
17	INH_A	I	PWM Input signal (high side), half-bridge A
18	INL_A	I	PWM Input signal (low side), half-bridge A
19	INH_B	I	PWM Input signal (high side), half-bridge B
20	INL_B	I	PWM Input signal (low side), half-bridge B
21	INH_C	I	PWM Input signal (high side), half-bridge C
22	INL_C	I	PWM Input signal (low side), half-bridge C
23	DVDD	P	Internal 3.3-V supply voltage. DVDD cap should connect to AGND. This is an output, but not specified to drive external circuitry.
24	REF	I	Reference voltage to set output of shunt amplifiers with a bias voltage which equals to half of the voltage set on this pin. Connect to ADC reference in microcontroller.
25	SO1	O	Output of current amplifier 1
26	SO2	O	Output of current amplifier 2
27	AVDD	P	Internal 6-V supply voltage, AVDD cap should connect to AGND. This is an output, but not specified to drive external circuitry.
28	AGND	P	Analog ground pin
29	PVDD1	P	Power supply pin for gate driver and current shunt amplifier. PVDD1 is independent of buck power supply, PVDD2. PVDD1 cap should connect to GND
30	SP2	I	Input of current amplifier 2 (connecting to positive input of amplifier). Recommend to connect to ground side of the sense resistor for the best common mode rejection.
31	SN2	I	Input of current amplifier 2 (connecting to negative input of amplifier).
32	SP1	I	Input of current amplifier 1 (connecting to positive input of amplifier). Recommend to connect to ground side of the sense resistor for the best common mode rejection.
33	SN1	I	Input of current amplifier 1 (connecting to negative input of amplifier).
34	SL_C	I	Low-Side MOSFET source connection, half-bridge C. Low-side V_{DS} measured between this pin and SH_C.
35	GL_C	O	Gate drive output for Low-Side MOSFET, half-bridge C
36	SH_C	I	High-Side MOSFET source connection, half-bridge C. High-side V_{DS} measured between this pin and PVDD1.
37	GH_C	O	Gate drive output for High-Side MOSFET, half-bridge C
38	BST_C	P	Bootstrap cap pin for half-bridge C
39	SL_B	I	Low-Side MOSFET source connection, half-bridge B. Low-side V_{DS} measured between this pin and SH_B.
40	GL_B	O	Gate drive output for Low-Side MOSFET, half-bridge B
41	SH_B	I	High-Side MOSFET source connection, half-bridge B. High-side V_{DS} measured between this pin and PVDD1.
42	GH_B	O	Gate drive output for High-Side MOSFET, half-bridge B
43	BST_B	P	Bootstrap cap pin for half-bridge B
44	SL_A	I	Low-Side MOSFET source connection, half-bridge A. Low-side V_{DS} measured between this pin and SH_A.
45	GL_A	O	Gate drive output for Low-Side MOSFET, half-bridge A
46	SH_A	I	High-Side MOSFET source connection, half-bridge A. High-side V_{DS} measured between this pin and PVDD1.
47	GH_A	O	Gate drive output for High-Side MOSFET, half-bridge A
48	BST_A	P	Bootstrap cap pin for half-bridge A
49	BIAS	I	Bias pin. Connect 1M- Ω resistor to GND, or 0.1 μ F capacitor to GND.
50, 51	PH	O	The source of the internal high side MOSFET of buck converter

Pin Functions (continued)

PIN		I/O ⁽¹⁾	DESCRIPTION
NO.	NAME		
52	BST_BK	P	Bootstrap cap pin for buck converter
53, 54	PVDD2	P	Power supply pin for buck converter, PVDD2 cap should connect to GND.
55	EN_BUCK	I	Enable buck converter. Internal pullup current source. Pull below 1.2 V to disable. Float to enable. Adjust the input undervoltage lockout with two resistors
56	SS_TR	I	Buck soft-start and tracking. An external capacitor connected to this pin sets the output rise time. Since the voltage on this pin overrides the internal reference, it can be used for tracking and sequencing. Cap should connect to GND
57	GND (PWR_PAD)	P	GND pin. The exposed power pad must be electrically connected to ground plane through soldering to PCB for proper operation and connected to bottom side of PCB through vias for better thermal spreading.

6 Specifications

6.1 Absolute Maximum Ratings

over operating free-air temperature range (unless otherwise noted)⁽¹⁾

			MIN	MAX	UNIT
V _{PVDD}	Supply voltage	Relative to PGND	-0.3	65	V
PVDD _{RAMP}	Maximum supply voltage ramp rate	Voltage rising up to PVDD _{MAX}		1	V/μs
V _{PGND}	Maximum voltage between PGND and GND		-0.3	0.3	V
I _{IN_MAX}	Maximum current, all digital and analog input pins except nFAULT and nOCTW pins		-1	1	mA
I _{IN_OD_MAX}	Maximum sinking current for open-drain pins (nFAULT and nOCTW Pins)			7	mA
V _{OPA_IN}	Voltage range for SPx and SNx pins		-0.6	0.6	V
V _{LOGIC}	Input voltage range for logic/digital pins (INH_A, INL_A, INH_B, INL_B, INH_C, INL_C, EN_GATE, M_PWM, M_OC, OC_ADJ, GAIN, DC_CAL)		-0.3	7	V
V _{GVDD}	Maximum voltage for GVDD pin			13.2	V
V _{AVDD}	Maximum voltage for AVDD pin			8	V
V _{DVDD}	Maximum voltage for DVDD pin			3.6	V
V _{REF}	Maximum reference voltage for current amplifier			7	V
I _{REF}	Maximum current for REF Pin			100	μA
T _J	Maximum operating junction temperature		-40	150	°C
T _{stg}	Storage temperature		-55	150	°C

(1) Stresses beyond those listed under *Absolute Maximum Ratings* may cause permanent damage to the device. These are stress ratings only, which do not imply functional operation of the device at these or any other conditions beyond those indicated under *Recommended Operating Conditions*. Exposure to absolute-maximum-rated conditions for extended periods may affect device reliability.

6.2 ESD Ratings

			VALUE	UNIT
V _(ESD)	Electrostatic discharge	Human-body model (HBM), per ANSI/ESDA/JEDEC JS-001 ⁽¹⁾	±2000	V
		Charged-device model (CDM), per JEDEC specification JESD22-C101 ⁽²⁾	±500	

(1) JEDEC document JEP155 states that 500-V HBM allows safe manufacturing with a standard ESD control process.

(2) JEDEC document JEP157 states that 250-V CDM allows safe manufacturing with a standard ESD control process.

6.3 Recommended Operating Conditions

		MIN	NOM	MAX	UNIT	
V _{PVDD}	DC supply voltage PVDD1 for normal operation	Relative to PGND		8	60	V
	DC supply voltage PVDD2 for buck converter		3.5	60	V	
I _{DIN_EN}	Input current of digital pins when EN_GATE is high			100	μA	
I _{DIN_DIS}	Input current of digital pins when EN_GATE is low			1	μA	
C _{O_OPA}	Maximum output capacitance on outputs of shunt amplifier			20	pF	
R _{DTC}	Dead time control resistor range. Time range is 50 ns (–GND) to 500 ns (150 kΩ) with a linear approximation.		0	150	kΩ	
I _{FAULT}	$\overline{\text{FAULT}}$ pin sink current. Open drain	V = 0.4 V		2	mA	
I _{OCTW}	$\overline{\text{OCTW}}$ pin sink current. Open drain	V = 0.4 V		2	mA	
V _{REF}	External voltage reference voltage for current shunt amplifiers		2	6	V	
f _{gate}	Operating switching frequency of gate driver	Qg(TOT) = 25 nC or total 30-mA gate drive average current		200	kHz	
T _A	Ambient temperature		–40	125	°C	

6.4 Thermal Information

THERMAL METRIC ⁽¹⁾		DRV8302	UNIT
		DCA (HTSSOP)	
		56 PINS	
R _{θJA}	Junction-to-ambient thermal resistance	30.3	°C/W
R _{θJC(top)}	Junction-to-case (top) thermal resistance	33.5	°C/W
R _{θJB}	Junction-to-board thermal resistance	17.5	°C/W
ψ _{JT}	Junction-to-top characterization parameter	0.9	°C/W
ψ _{JB}	Junction-to-board characterization parameter	7.2	°C/W
R _{θJC(bot)}	Junction-to-case (bottom) thermal resistance	0.9	°C/W

(1) For more information about traditional and new thermal metrics, see the *Semiconductor and IC Package Thermal Metrics* application report (SPRA953).

6.5 Electrical Characteristics

PVDD = 8 V to 60 V, T_C = 25°C, unless specified under test condition

PARAMETER		TEST CONDITIONS	MIN	TYP	MAX	UNIT
INPUT PINS: INH_X, INL_X, M_PWM, M_OC, GAIN, EN_GATE, DC_CAL						
V _{IH}	High input threshold		2			V
V _{IL}	Low input threshold				0.8	V
R _{EN_GATE}	Internal pulldown resistor for EN_GATE			100		kΩ
R _{INH_X}	Internal pulldown resistor for high side PWMs (INH_A, INH_B, and INH_C)	EN_GATE high		100		kΩ
R _{INL_X}	Internal pulldown resistor for low side PWMs (INL_A, INL_B, and INL_C)	EN_GATE high		100		kΩ
R _{M_PWM}	Internal pulldown resistor for M_PWM	EN_GATE high		100		kΩ
R _{M_OC}	Internal pulldown resistor for M_OC	EN_GATE high		100		kΩ
R _{DC_CAL}	Internal pulldown resistor for DC_CAL	EN_GATE high		100		kΩ
OUTPUT PINS: nFAULT AND nOCTW						
V _{OL}	Low output threshold	I _O = 2 mA			0.4	V
V _{OH}	High output threshold	External 47-kΩ pullup resistor connected to 3-5.5 V	2.4			V
I _{OH}	Leakage current on open-drain pins When logic high (nFAULT and nOCTW)				1	μA
GATE DRIVE OUTPUT: GH_A, GH_B, GH_C, GL_A, GL_B, GL_C						
V _{GX_NORM}	Gate driver V _{gs} voltage	PVDD = 8 V to 60 V	9.5		11.5	V
I _{oso1}	Maximum source current setting 1, peak	V _{gs} of FET equals to 2 V		1.7		A
I _{osi1}	Maximum sink current setting 1, peak	V _{gs} of FET equals to 8 V		2.3		A
R _{gate_off}	Gate output impedance during standby mode when EN_GATE low (pins GH_x, GL_x)		1.6		2.4	kΩ
SUPPLY CURRENTS						
I _{PVDD1_STB}	PVDD1 supply current, standby	EN_GATE is low. PVDD1 = 8 V.		20	50	μA
I _{PVDD1_OP}	PVDD1 supply current, operating	EN_GATE is high, no load on gate drive output, switching at 10 kHz, 100-nC gate charge		15		mA
I _{PVDD1_HI_Z}	PVDD1 Supply current, HiZ	EN_GATE is high, gate not switching	2	5	11	mA
INTERNAL REGULATOR VOLTAGE						
A _{VDD}	AVDD voltage		6	6.5	7	V
D _{VDD}	DVDD voltage		3	3.3	3.6	V
VOLTAGE PROTECTION						
V _{PVDD_UV}	Undervoltage protection limit, PVDD				6	V
V _{GVDD_UV}	Undervoltage protection limit, GVDD				8	V
V _{GVDD_OV}	Overvoltage protection limit, GVDD			16		V
CURRENT PROTECTION, (VDS SENSING)						
V _{DS_OC}	Drain-source voltage protection limit		0.125		2.4	V
T _{oc}	OC sensing response time			1.5		μs
T _{OC_PULSE}	$\overline{\text{OCTW}}$ pin reporting pulse stretch length for OC event			64		μs

6.6 Gate Timing and Protection Characteristics

			MIN	NOM	MAX	UNIT
TIMING, OUTPUT PINS						
$t_{pd,lf-O}$	Positive input falling to GH_x falling	CL=1 nF, 50% to 50%		45		ns
$t_{pd,lr-O}$	Positive input rising to GL_x falling	CL=1 nF, 50% to 50%		45		ns
T_{d_min}	Minimum dead time after hand shaking ⁽¹⁾				50	ns
T_{dtp}	Dead Time	With R _{DTC} set to different values	50		500	ns
t_{GDr}	Rise time, gate drive output	CL=1 nF, 10% to 90%		25		ns
t_{GDF}	Fall time, gate drive output	CL=1 nF, 90% to 10%		25		ns
T_{ON_MIN}	Minimum on pulse	Not including handshake communication. Hiz to on state, output of gate driver			50	ns
T_{pd_match}	Propagation delay matching between high side and low side				5	ns
T_{dt_match}	Deadtime matching				5	ns
TIMING, PROTECTION AND CONTROL						
$t_{pd,R_GATE-OP}$	Start-up time, from EN_GATE active high to device ready for normal operation	PVDD is up before start-up, all charge pump caps and regulator caps as in recommended condition		5	10	ms
$t_{pd,R_GATE-Quick}$	If EN_GATE goes from high to low and back to high state within quick reset time, it will only reset all faults and gate driver without powering down charge pump, current amp, and related internal voltage regulators.	Maximum low pulse time			10	us
$t_{pd,E-L}$	Delay, error event to all gates low			200		ns
$t_{pd,E-FAULT}$	Delay, error event to \overline{FAULT} low			200		ns
OTW_CLR	Junction temperature for resetting overtemperature warning			115		°C
OTW_SET/OTSD_CLR	Junction temperature for overtemperature warning and resetting overtemperature shut down			130		°C
OTSD_SET	Junction temperature for overtemperature shut down			150		°C

(1) Dead time programming definition: Adjustable delay from GH_x falling edge to GL_X rising edge, and GL_X falling edge to GH_X rising edge. This is a minimum dead-time insertion. It is not added to the value set by the microcontroller externally.

6.7 Current Shunt Amplifier Characteristics

$T_C = 25^\circ\text{C}$ unless otherwise specified

PARAMETER		TEST CONDITIONS	MIN	TYP	MAX	UNIT
G1	Gain option 1	(GAIN = 0 V)	9.5	10	10.5	V/V
G2	Gain option 2	(GAIN = 2 V)	38	40	42	V/V
Tsettling	Settling time to 1%	$T_C = 0^\circ\text{C}$ to 60°C , G = 10, Vstep = 2 V		300		ns
Tsettling	Settling time to 1%	$T_C = 0^\circ\text{C}$ to 60°C , G = 40, Vstep = 2 V		1.2		μs
Vswing	Output swing linear range		0.3		5.7	V
Slew Rate		G = 10		10		V/μs
DC_offset	Offset error RTI	G = 10 with input shorted			4	mV
Drift_offset	Offset drift RTI			10		μV/C
Ibias	Input bias current				100	μA
Vin_com	Common input mode range		-0.15		0.15	V
Vin_dif	Differential input range		-0.3		0.3	V
Vo_bias	Output bias	With zero input current, Vref up to 6 V	-0.5%	0.5xVref	0.5%	V
CMRR_OV	Overall CMRR with gain resistor mismatch	CMRR at DC, gain = 10	70	85		dB

6.8 Buck Converter Characteristics

 $T_C = 25^\circ\text{C}$ unless otherwise specified

PARAMETER		TEST CONDITIONS	MIN	TYP	MAX	UNIT
V_{UVLO}	Internal undervoltage lockout threshold	No voltage hysteresis, rising and falling		2.5		V
$I_{SD(PVDD2)}$	Shutdown supply current	$EN = 0\text{ V}$, 25°C , $3.5\text{ V} \leq V_{IN} \leq 60\text{ V}$		1.3	4	μA
$I_{NON_SW(PVDD2)}$	Operating: nonswitching supply current	$V_{SENSE} = 0.83\text{ V}$, $V_{IN} = 12\text{ V}$		116	136	μA
V_{EN_BUCK}	Enable threshold voltage	No voltage hysteresis, rising and falling	1.11	1.25	1.36	V
R_{DS_ON}	On-resistance	$V_{IN} = 12\text{ V}$, $BOOT-PH = 6\text{ V}$		200	410	$\text{m}\Omega$
I_{LIM}	Current limit threshold	$V_{IN} = 12\text{ V}$, $T_J = 25^\circ\text{C}$	1.8	2.7		A
OTSD_BK	Thermal shutdown			150		$^\circ\text{C}$
F_{sw}	Switching frequency	$R_T = 200\text{ k}\Omega$	450	581	720	kHz
PWRGD	VSENSE threshold	VSENSE falling		92%		
		VSENSE rising		94%		
		VSENSE rising		109%		
		VSENSE falling		107%		
	Hysteresis	VSENSE falling		2%		
	Output high leakage	$V_{SENSE} = V_{REF}$, $V(PWRGD) = 5.5\text{ V}$, 25°C		10		nA
	On resistance	$I(PWRGD) = 3\text{ mA}$, $V_{SENSE} < 0.79\text{ V}$		50		Ω

6.9 Typical Characteristics

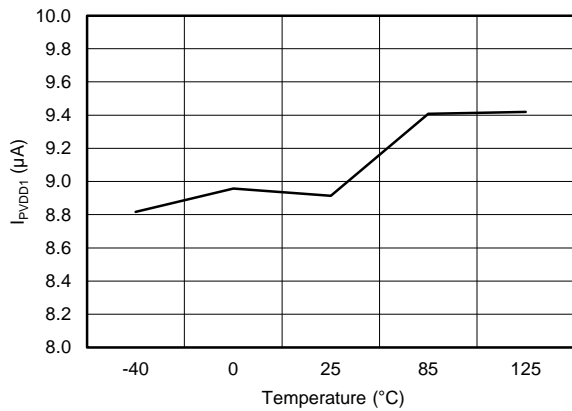

Figure 1. I_{PVDD1} vs Temperature (PVDD1 = 8 V, EN_GATE = LOW)

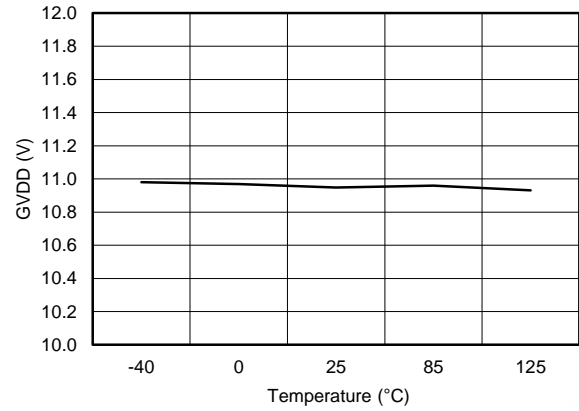

Figure 2. GVDD vs Temperature (PVDD1 = 8 V, EN_GATE = HIGH)

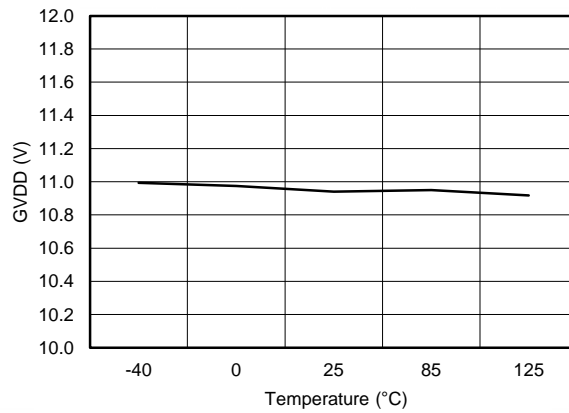

Figure 3. GVDD vs Temperature (PVDD1 = 60 V, EN_GATE = HIGH)

7 Detailed Description

7.1 Overview

The DRV8302 is a 8-V to 60-V, gate driver IC for three phase motor drive applications. This device reduces external component count by integrating three half-bridge drivers, two current shunt amplifiers, and a switching buck converter. The DRV8302 provides overcurrent, overtemperature, and undervoltage protection. Fault conditions are indicated through the nFAULT and nOCTW pins.

Adjustable dead time control allows for finely tuning the switching of the external MOSFETs. Internal hand shaking is used to prevent shoot-through current. VDS sensing of the external MOSFETs allows for the DRV8302 to detect overcurrent conditions and respond appropriately. The VDS trip point can be set through a hardware pin.

The highly configurable buck converter can support a wide range of output options. This allows the DRV8302 to provide a power supply rail for the controller and lower voltage components.

7.2 Function Block Diagram

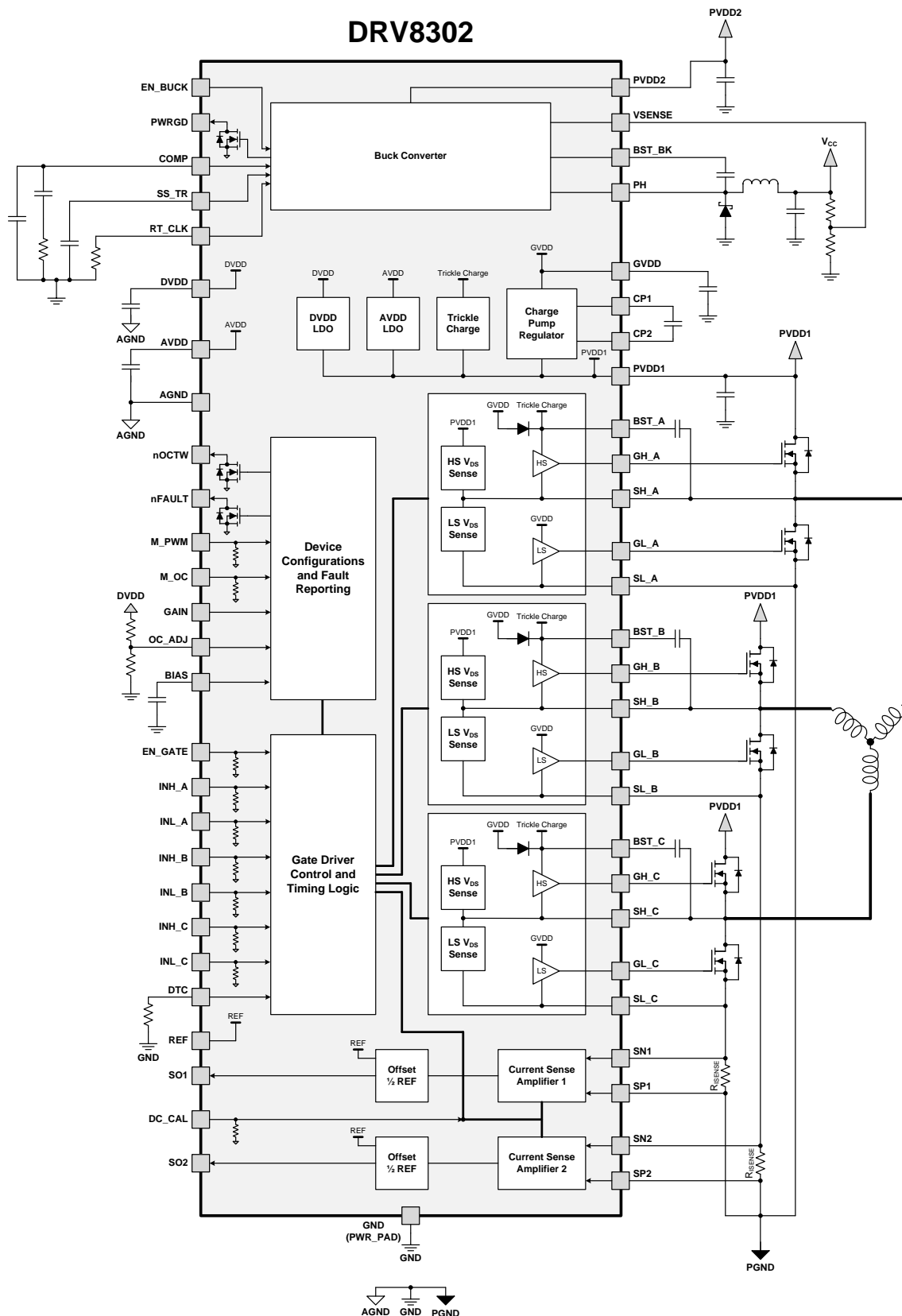

7.3 Feature Description

7.3.1 Three-Phase Gate Driver

The half-bridge drivers use a bootstrap configuration with a trickle charge pump to support 100% duty cycle operation. Each half-bridge is configured to drive two N-channel MOSFETs, one for the high-side and one for the low-side. The half-bridge drivers can be used in combination to drive a 3-phase motor or separately to drive various other loads.

The internal dead times are adjustable to accommodate a variety of external MOSFETs and applications. The dead time is adjusted with an external resistor on the DTC pin. Shorting the DTC pin to ground provides the minimum dead time (50 ns). There is an internal hand shake between the high side and low side MOSFETs during switching transitions to prevent current shoot-through.

The three-phase gate driver can provide up to 30 mA of average gate driver current. This can support switching frequencies up to 200 kHz when the MOSFET $Q_g = 25$ nC. The high side gate drive will survive negative output from the half-bridge up to -10 V for 10 ns. During EN_GATE low and fault conditions the gate driver keeps the external MOSFETs in high impedance mode.

Each MOSFET gate driver has a V_{DS} sensing circuit for overcurrent protection. The sense circuit measures the voltage from the drain to the source of the external MOSFETs while the MOSFET is enabled. This voltage is compared against the programmed trip point to determine if an overcurrent event has occurred. The trip voltage is set through the OC_ADJ pin with a voltage usually set with a resistor divider. The high-side sense is between the PVDD1 and SH_X pins. The low-side sense is between the SH_X and SL_X pins. Ensuring a differential, low impedance connection to the external MOSFETs for these lines helps provide accurate VDS sensing. The DRV8302 provides both cycle-by-cycle current limiting and latch overcurrent shutdown of the external MOSFET through the M_OC pin.

The DRV8302 allows for both 6-PWM and 3-PWM control through the M_PWM pin.

Table 1. 6-PWM Mode

INL_X	INH_X	GL_X	GH_X
0	0	L	L
0	1	L	H
1	0	H	L
1	1	L	L

Table 2. 3-PWM Mode

INL_X	INH_X	GL_X	GH_X
X	0	H	L
X	1	L	H

Table 3. Gate Driver External Components

NAME	PIN 1	PIN 2	RECOMMENDED
R _{nOCTW}	nOCTW	V _{CC} ⁽¹⁾	≥10 kΩ
R _{nFAULT}	nFAULT	V _{CC} ⁽¹⁾	≥10 kΩ
R _{DTC}	DTC	GND (PowerPAD)	0 to 150 kΩ (50 ns to 500 ns)
C _{GVDD}	GVDD	GND (PowerPAD)	2.2 μF (20%) ceramic, ≥ 16 V
C _{CP}	CP1	CP2	0.022 μF (20%) ceramic, rated for PVDD1
C _{DVDD}	DVDD	AGND	1 μF (20%) ceramic, ≥ 6.3 V
C _{AVDD}	AVDD	AGND	1 μF (20%) ceramic, ≥ 10 V
C _{PVDD1}	PVDD1	GND (PowerPAD)	≥4.7 μF (20%) ceramic, rated for PVDD1
C _{BST_X}	BST_X	SH_X	0.1 μF (20%) ceramic, ≥ 16 V

(1) V_{CC} is the logic supply to the MCU

7.3.2 Current Shunt Amplifiers

The DRV8302 includes two high performance current shunt amplifiers to accurate low-side, inline current measurement.

The current shunt amplifiers have 2 programmable GAIN settings through the GAIN pin. These are 10, and 40 V/V.

They provide output offset up to 3 V to support bidirectional current sensing. The offset is set to half the voltage on the reference pin (REF).

To minimize DC offset and drift overtime, a calibration method is provided through either the DC_CAL pin. When DC calibration is enabled, the device shorts the input of the current shunt amplifier and disconnect the load. DC calibration can be done at any time, even during MOSFET switching, since the load is disconnected. For the best results, perform the DC calibration during the switching OFF period, when no load is present, to reduce the potential noise impact to the amplifier.

The output of current shunt amplifier can be calculated as:

$$V_O = \frac{V_{REF}}{2} - G \times (SN_x - SP_x)$$

where

- VREF is the reference voltage (REF pin)
- G is the gain of the amplifier (10 or 40 V/V)
- SN_x and SP_x are the inputs of channel x

(1)

SP_x should connect to resistor ground for the best common mode rejection.

Figure 4 shows current amplifier simplified block diagram.

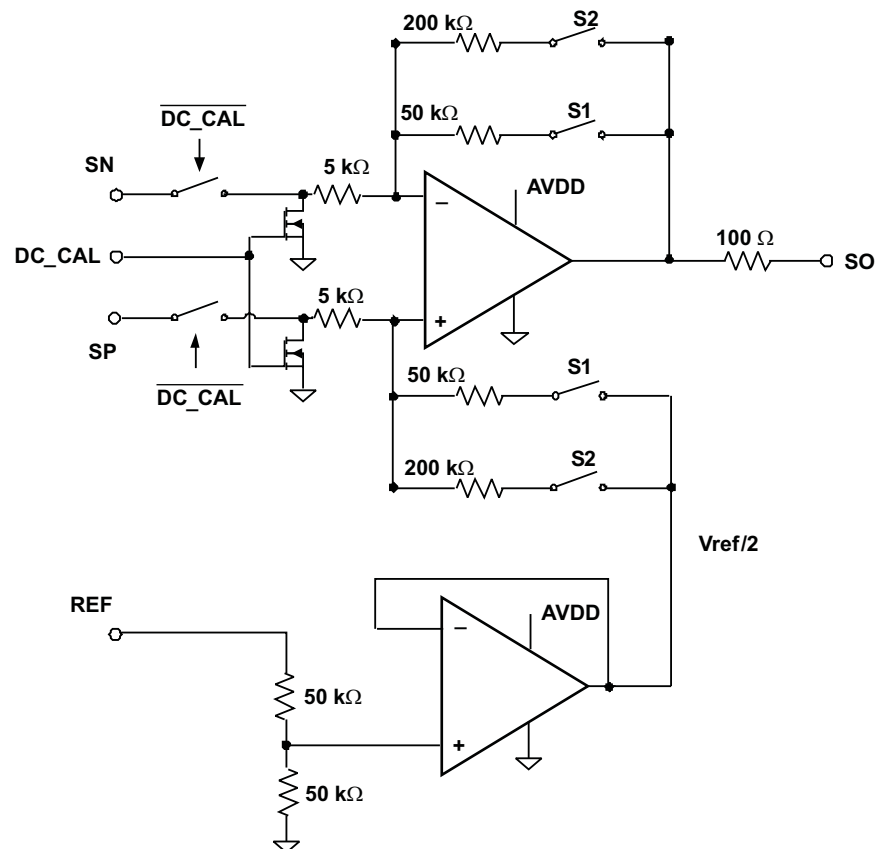

Figure 4. Current Shunt Amplifier Simplified Block Diagram

7.3.3 Buck Converter

The DRV8302 uses an integrated TPS54160 1.5-A, 60-V, step-down DC-DC converter. Although integrated in the same device, the buck converter is designed completely independent of the rest of the gate driver circuitry. Because the buck converter can support external MCU or other external power need, the independency of buck operation is crucial for a reliable system; this gives the buck converter minimum impact from gate driver operations. Some examples are: when gate driver shuts down due to any failure, the buck still operates unless the fault is coming from the buck itself. The buck keeps operating at much lower PVDD of 3.5 V, assuring the system has a smooth power-up and power-down sequence when gate driver is not able to operate due to a low PVDD.

For proper selection of the buck converter external components, see the data sheet, *TPS54160 1.5-A, 60-V, Step-Down DC/DC Converter With Eco-mode™*, [SLVSB56](#).

The buck has an integrated high-side N-channel MOSFET. To improve performance during line and load transients the device implements a constant frequency, current mode control which reduces output capacitance and simplifies external frequency compensation design.

The wide switching frequency of 300 kHz to 2200 kHz allows for efficiency and size optimization when selecting the output filter components. The switching frequency is adjusted using a resistor to ground on the RT_CLK pin. The device has an internal phase lock loop (PLL) on the RT_CLK pin that is used to synchronize the power switch turn on to a falling edge of an external system clock.

The buck converter has a default start-up voltage of approximately 2.5 V. The EN_BUCK pin has an internal pullup current source that can be used to adjust the input voltage undervoltage lockout (UVLO) threshold with two external resistors. In addition, the pullup current provides a default condition. When the EN_BUCK pin is floating the device will operate. The operating current is 116 μ A when not switching and under no load. When the device is disabled, the supply current is 1.3 μ A.

The integrated 200-m Ω high-side MOSFET allows for high-efficiency power supply designs capable of delivering 1.5 A of continuous current to a load. The bias voltage for the integrated high side MOSFET is supplied by a capacitor on the BOOT to PH pin. The boot capacitor voltage is monitored by an UVLO circuit that turns the high side MOSFET off when the boot voltage falls below a preset threshold. The buck can operate at high duty cycles because of the boot UVLO. The output voltage can be stepped down to as low as the 0.8-V reference.

The BUCK has a power good comparator (PWRGD) which asserts when the regulated output voltage is less than 92% or greater than 109% of the nominal output voltage. The PWRGD pin is an open-drain output that deasserts when the VSENSE pin voltage is between 94% and 107% of the nominal output voltage, allowing the pin to transition high when a pullup resistor is used.

The BUCK minimizes excessive output overvoltage (OV) transients by taking advantage of the OV power good comparator. When the OV comparator is activated, the high-side MOSFET is turned off and masked from turning on until the output voltage is lower than 107%.

The SS_TR (slow start/tracking) pin is used to minimize inrush currents or provide power supply sequencing during power-up. A small value capacitor should be coupled to the pin to adjust the slow start time. A resistor divider can be coupled to the pin for critical power supply sequencing requirements. The SS_TR pin is discharged before the output powers up. This discharging ensures a repeatable restart after an overtemperature fault,

The BUCK, also, discharges the slow-start capacitor during overload conditions with an overload recovery circuit. The overload recovery circuit slow-starts the output from the fault voltage to the nominal regulation voltage once a fault condition is removed. A frequency foldback circuit reduces the switching frequency during start-up and overcurrent fault conditions to help control the inductor current.

Table 4. Buck Regulator External Components

NAME	PIN 1	PIN 2	RECOMMENDED
R _{RT_CLK}	RT_CLK	GND (PowerPAD)	See Buck Converter
C _{COMP}	COMP	GND (PowerPAD)	See Buck Converter
R _{C_COMP}	COMP	GND (PowerPAD)	See Buck Converter
R _{VSENSE1}	PH (Filtered)	VSENSE	See Buck Converter
R _{VSENSE2}	VSENSE	GND (PowerPAD)	See Buck Converter
R _{PWRGD}	PWRGD	V _{CC} ⁽¹⁾	≥ 10 kΩ
L _{PH}	PH	PH (Filtered)	See Buck Converter
D _{PH}	PH	GND (PowerPAD)	See Buck Converter
C _{PH}	PH (Filtered)	GND (PowerPAD)	See Buck Converter
C _{BST_BK}	BST_BK	PH	See Buck Converter
C _{PVDD2}	PVDD2	GND (PowerPAD)	≥ 4.7 μF (20%) ceramic, rated for PVDD2
C _{SS_TR}	SS_TR	GND (PowerPAD)	See Buck Converter

(1) V_{CC} is the logic supply to the MCU

7.3.4 Protection Features

The DRV8302 provides a broad range of protection features and fault condition reporting. The DRV8302 has undervoltage and overtemperature protection for the IC. It also has overcurrent and undervoltage protection for the MOSFET power stage. In fault shut down conditions all gate driver outputs is held low to ensure the external MOSFETs are in a high impedance state.

7.3.4.1 Overcurrent Protection (OCP) and Reporting

To protect the power stage from damage due to excessive currents, V_{DS} sensing circuitry is implemented in the DRV8302. Based on the R_{DS(on)} of the external MOSFETs and the maximum allowed I_{DS}, a voltage threshold can be determined to trigger the overcurrent protection features when exceeded. The voltage threshold is programmed through the OC_ADJ pin by applying an external reference voltage with a DAC or resistor divider from DVDD. Overcurrent protection should be used as a protection scheme only; it is not intended as a precise current regulation scheme. There can be up to a 20% tolerance across channels for the V_{DS} trip point.

$$V_{DS} = I_{DS} \times R_{DS(on)} \quad (2)$$

The V_{DS} sense circuit measures the voltage from the drain to the source of the external MOSFET while the MOSFET is enabled. The high-side sense is between the PVDD and SH_X pins. The low-side sense is between the SH_X and SL_X pins. Ensuring a differential, low impedance connection to the external MOSFETs for these lines helps provide accurate V_{DS} sensing.

There are two different overcurrent modes that can be set through the M_OC pin.

7.3.4.1.1 Current Limit Mode (M_OC = LOW)

In current limit mode the devices uses current limiting instead of device shutdown during an overcurrent event. After the overcurrent event, the MOSFET in which the overcurrent was detected in will shut off until the next PWM cycle. The overcurrent event will be reported through the nOCTW pin. The nOCTW pin will be held low for a maximum 64 μs period (internal timer) or until the next PWM cycle. If another overcurrent event is triggered from another MOSFET, during a previous overcurrent event, the reporting will continue for another 64 μs period (internal timer will restart) or until both PWM signals cycle.

In current limit mode the device uses current limiting instead of device shutdown during an overcurrent event. In this mode the device reports overcurrent events through the nOCTW pin. The nOCTW pin will be held low for a maximum 64 μs period (internal timer) or until the next PWM cycle. If another overcurrent event is triggered from another MOSFET, during a previous overcurrent event, the reporting will continue for another 64 μs period (internal timer will restart) or until both PWM signals cycle.

7.3.4.1.2 OC Latch Shutdown Mode

When an overcurrent event occurs, both the high-side and low-side MOSFETs will be disabled in the corresponding half-bridge. The nFAULT pin will latch until the fault is reset through a quick EN_GATE reset pulse.

7.3.4.2 OC_ADJ

When external MOSFET is turned on, the output current flows through the on resistance, $R_{DS(on)}$ of the MOSFET, which creates a voltage drop V_{DS} . The over current protection event will be enabled when the V_{DS} exceeds a pre-set value. The voltage on OC_ADJ pin will be used to pre-set the OC tripped value. The OC tripped value I_{OC} has to meet following equations:

$$\frac{R2}{(R1 + R2)} \times DVDD = V_{DS}$$

where

- $R1 + R2 \geq 1 \text{ K}\Omega$
 - $DVDD = 3.3 \text{ V}$
- (3)

$$I_{OC} = \frac{V_{DS}}{R_{DS(on)}}$$
(4)

Connect OC_ADJ pin to DVDD to disable the over-current protection feature.

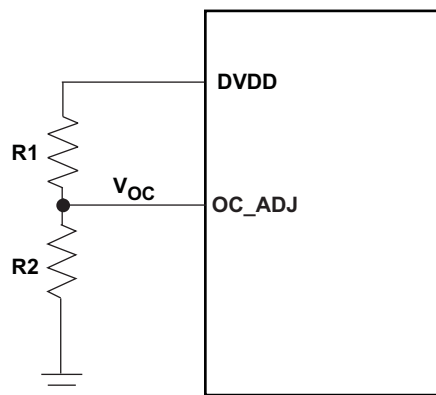

Figure 5. OC_ADJ Current Programming Pin Connection

7.3.4.3 Undervoltage Protection (UVLO)

To protect the power output stage during start-up, shutdown, and other possible undervoltage conditions, the DRV8302 provides undervoltage protection by driving the gate drive outputs (GH_X, GL_X) low whenever PVDD or GVDD are below their undervoltage thresholds (PVDD_UV/GVDD_UV). This will put the external MOSFETs in a high impedance state.

A specific PVDD1 undervoltage transient brownout from 13 to 15 μs can cause the DRV8302 to become unresponsive to external inputs until a full power cycle. The transient condition consists of having PVDD1 greater than the PVDD_UV level and then PVDD1 dropping below the PVDD_UV level for a specific period of 13 to 15 μs . Transients shorter or longer than 13 to 15 μs will not affect the normal operation of the undervoltage protection. Additional bulk capacitance can be added to PVDD1 to reduce undervoltage transients.

7.3.4.4 Overvoltage Protection (GVDD_OV)

The device will shut down both the gate driver and charge pump if the GVDD voltage exceeds the GVDD_OV threshold to prevent potential issues related to the GVDD pin or the charge pump (For example, short of external GVDD cap or charge pump). The fault is a latched fault and can only be reset through a reset transition on the EN_GATE pin.

7.3.4.5 Overtemperature Protection

A two-level overtemperature detection circuit is implemented:

- Level 1: overtemperature warning (OTW)
OTW is reported through nOCTW pin.
- Level 2: overtemperature (OT) latched shut down of gate driver and charge pump (OTSD_GATE)
Fault will be reported to nFAULT pin. This is a latched shut down, so gate driver will not be recovered automatically even if OT condition is not present anymore. An EN_GATE reset through pin is required to recover gate driver to normal operation after temperature goes below a preset value, t_{OTSD_CLR} .

7.3.4.6 Fault and Protection Handling

The nFAULT pin indicates an error event with shut down has occurred such as over-current, overtemperature, overvoltage, or undervoltage. Note that nFAULT is an open-drain signal. nFAULT goes high when gate driver is ready for PWM signal (internal EN_GATE goes high) during start-up.

The nOCTW pin indicates an overtemperature or over current event that is not necessarily related to shut down.

Following is the summary of all protection features and their reporting structure:

Table 5. Fault and Warning Reporting and Handling

EVENT	ACTION	LATCH	REPORTING ON nFAULT PIN	REPORTING ON nOCTW PIN
PVDD undervoltage	External FETs HiZ; Weak pulldown of all gate driver output	N	Y	N
DVDD undervoltage	External FETs HiZ; Weak pulldown of all gate driver output; When recovering, reset all status registers	N	Y	N
GVDD undervoltage	External FETs HiZ; Weak pulldown of all gate driver output	N	Y	N
GVDD overvoltage	External FETs HiZ; Weak pulldown of all gate driver output Shut down the charge pump Won't recover and reset through SPI reset command or quick EN_GATE toggling	Y	Y	N
OTW	None	N	N	Y
OTSD_GATE	Gate driver latched shut down. Weak pulldown of all gate driver output to force external FETs HiZ Shut down the charge pump	Y	Y	Y
OTSD_BUCK	OTSD of Buck	Y	N	N
Buck output undervoltage	UVLO_BUCK: auto-restart	N	Y, in PWRGD pin	N
Buck overload	Buck current limiting (HiZ high side until current reaches zero and then auto-recovering)	N	N	N
External FET overload – current limit mode	External FETs current Limiting (only OC detected FET)	N	N	Y
External FET overload – Latch mode	Weak pulldown of gate driver output and PWM logic "0" of LS and HS in the same phase. External FETs HiZ	Y	Y	Y
External FET overload – reporting only mode	Reporting only	N	N	Y

7.4 Device Functional Modes

7.4.1 EN_GATE

EN_GATE low is used to put gate driver, charge pump, current shunt amplifier, and internal regulator blocks into a low-power consumption mode to save energy. The device will put the MOSFET output stage to high-impedance mode as long as PVDD is still present.

When the EN_GATE pin goes low to high, it goes through a power-up sequence, and enable gate driver, current amplifiers, charge pump, internal regulator, and so forth and reset all latched faults related to gate driver block. All latched faults can be reset when EN_GATE is toggled after an error event unless the fault is still present.

When EN_GATE goes from high to low, it will shut down gate driver block immediately, so gate output can put external FETs in high impedance mode. It will then wait for 10 μ s before completely shutting down the rest of the blocks. A quick fault reset mode can be done by toggling EN_GATE pin for a very short period (less than 10 μ s). This will prevent the device from shutting down the other functional blocks such as charge pump and internal regulators and bring a quicker and simple fault recovery. To perform a full reset, EN_GATE should be toggled for longer than 20 μ s. This allows for all of the blocks to completely shut down and reach known states.

An EN_GATE reset pulse (high \rightarrow low \rightarrow high) from 10 to 20 μ s should not be applied to the EN_GATE pin. The DRV8301 has a transition area from the quick to full reset modes that can cause the device to become unresponsive to external inputs until a full power cycle. An RC filter can be added externally to the pin if reset pulses with this period are expected to occur on the EN_GATE pin.

One exception is to reset a GVDD_OV fault. A quick EN_GATE quick fault reset will not work with GVDD_OV fault. A complete EN_GATE with low level holding longer than 20 μ s is required to reset GVDD_OV fault. TI highly recommends inspecting the system and board when GVDD_OV occurs.

7.4.2 DTC

Dead time can be programmed through DTC pin. A resistor should be connected from DTC to ground to control the dead time. Dead time control range is from 50 ns to 500 ns. Short DTC pin to ground provides minimum dead time (50 ns). Resistor range is 0 to 150 k Ω . Dead time is linearly set over this resistor range. Current shoot-through prevention protection will be enabled in the device all time independent of dead time setting and input mode setting.

8 Application and Implementation

NOTE

Information in the following applications sections is not part of the TI component specification, and TI does not warrant its accuracy or completeness. TI's customers are responsible for determining suitability of components for their purposes. Customers should validate and test their design implementation to confirm system functionality.

8.1 Application Information

The DRV8302 is a gate driver designed to drive a 3-phase BLDC motor in combination with external power MOSFETs. The device provides a high level of integration with three half-bridge gate drivers, two current shunt amplifiers, overcurrent protection, and a step-down buck regulator.

8.1.1 Gate Driver Power Up Sequencing Errata

The DRV8301 gate drivers may not correctly power-up if a voltage greater than 8.5 V is present on any SH_X pin when EN_GATE is brought logic high (device enabled) after PVDD1 power is applied (PVDD1 > PVDD_UV). This sequence should be avoided by ensuring the voltage levels on the SH_X pins are less than 8.5 V when the DRV8301 is enabled through EN_GATE.

8.2 Typical Application

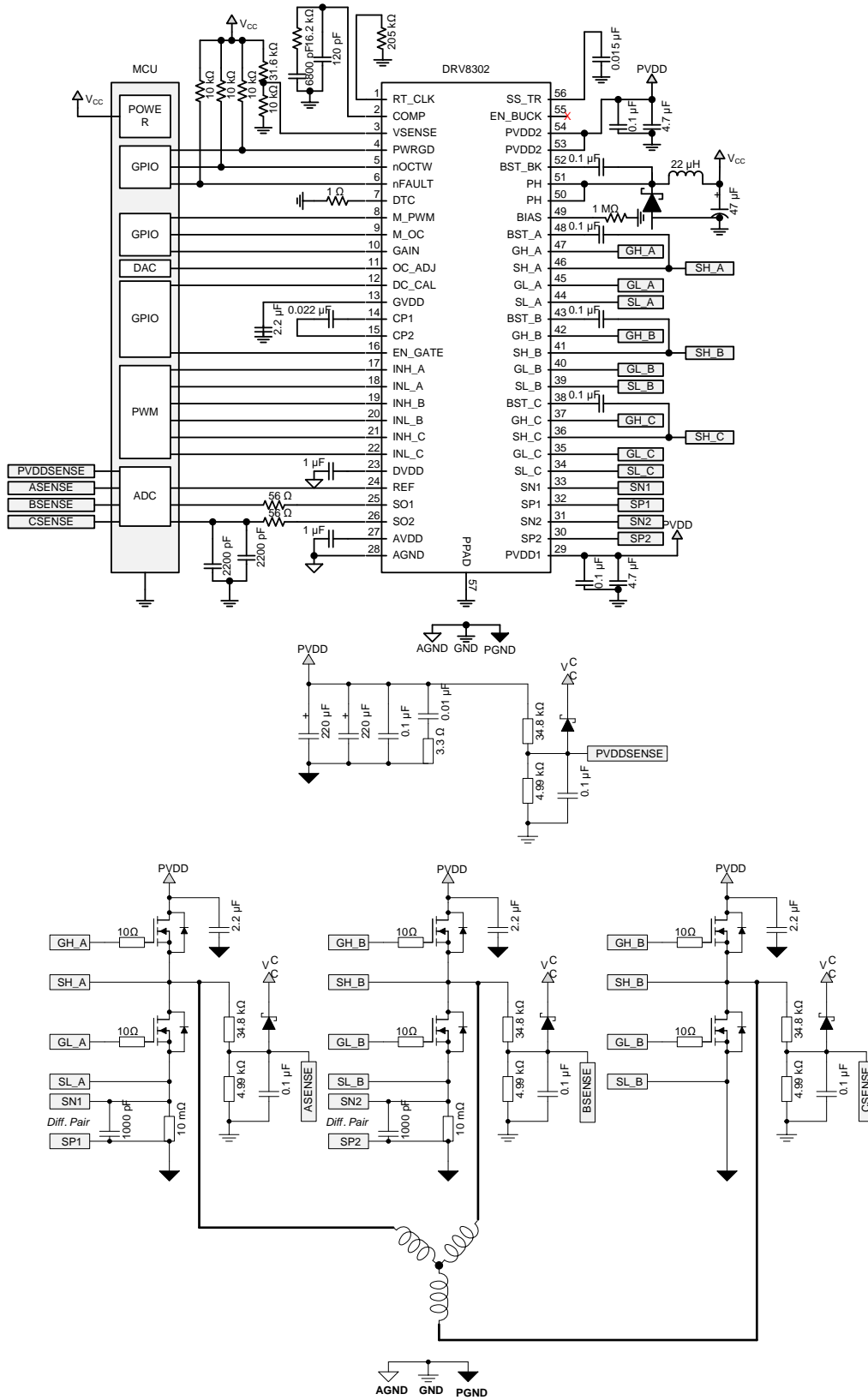

Figure 6. Typical Application Schematic

Typical Application (continued)

Example:

Buck: PVDD = 3.5 V – 40 V, I_{out_max} = 1.5 A, V_o = 3.3 V, F_s = 570 kHz

8.2.1 Design Requirements

Table 6. Design Parameters

DESIGN PARAMETER	REFERENCE	VALUE
Supply voltage	PVDD	24 V
Motor winding resistance	M _R	0.5 Ω
Motor winding inductance	M _L	0.28 mH
Motor poles	M _P	16 poles
Motor rated RPM	M _{RPM}	4000 RPM
Target full-scale current	I _{MAX}	14 A
Sense resistor	R _{SENSE}	0.01 Ω
MOSFET Q _g	Q _g	29 nC
MOSFET R _{DS(on)}	R _{DS(on)}	4.7 mΩ
VDS trip level	OC_ADJ_SET	0.123 V
Switching frequency	f _{SW}	45 kHz
Series gate resistance	R _{GATE}	10 Ω
Amplifier reference	V _{REF}	3.3 V
Amplifier gain	Gain	10 V/V

8.2.2 Detailed Design Procedure

8.2.2.1 Gate Drive Average Current Load

The gate drive supply (GVDD) of the DRV8302 can deliver up to 30 mA (RMS) of current to the external power MOSFETs. Use [Equation 5](#) to determine the approximate RMS load on the gate drive supply:

$$\text{Gate Drive RMS Current} = \text{MOSFET } Q_g \times \text{Number of Switching MOSFETs} \times \text{Switching Frequency} \quad (5)$$

Example:

$$7.83 \text{ mA} = 29 \text{ nC} \times 6 \times 45 \text{ kHz} \quad (6)$$

This is a rough approximation only.

8.2.2.2 Overcurrent Protection Setup

The DRV8302 provides overcurrent protection for the external power MOSFETs through the use of VDS monitors for both the high side and low side MOSFETs. These are intended for protecting the MOSFET in overcurrent conditions and not for precise current regulation.

The overcurrent protection works by monitoring the VDS voltage of the external MOSFET and comparing it against the OC_ADJ pin voltage. If the VDS exceeds the OC_ADJ pin voltage the DRV8302 takes action according to the M_OC pin.

$$\text{Overcurrent Trip} = \text{OC_ADJ_SET} / \text{MOSFET } R_{DS(on)} \quad (7)$$

Example:

$$26.17 \text{ A} = 0.123 \text{ V} / 4.7 \text{ m}\Omega \quad (8)$$

MOSFET R_{DS(on)} changes with temperature and this will affect the overcurrent trip level.

8.2.2.3 Sense Amplifier Setup

The DRV8302 provides two bidirectional low-side current shunt amplifiers. These can be used to sense a sum of the three half-bridges, two of the half-bridges individually, or in conjunction with an additional shunt amplifier to sense all three half-bridges individually.

1. Determine the peak current that the motor will demand (I_{MAX}). This will be dependent on the motor

parameters and your specific application. $I_{(MAX)}$ in this example is 14 A.

2. Determine the available voltage range for the current shunt amplifier. This will be \pm half of the amplifier reference voltage (V_{REF}). In this case the available range is ± 1.65 V.
3. Determine the sense resistor value and amplifier gain settings. There are common tradeoffs for both the sense resistor value and amplifier gain. The larger the sense resistor value, the better the resolution of the half-bridge current. This comes at the cost of additional power dissipated from the sense resistor. A larger gain value will allow you to decrease the sense resistor, but at the cost of increased noise in the output signal. This example uses a 0.01- Ω sense resistor and the minimum gain setting of the DRV8302 (10 V/V). These values allow the current shunt amplifiers to measure ± 16.5 A (some additional margin on the 14-A requirement).

8.2.3 Application Curves

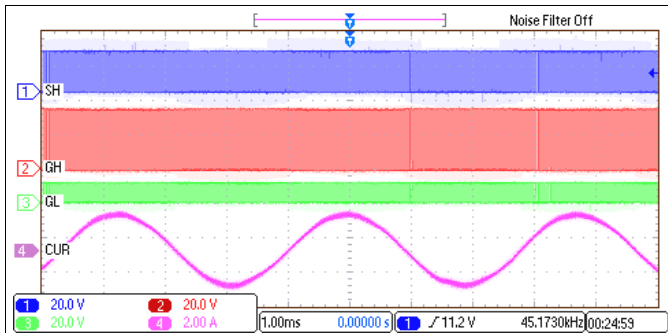

Figure 7. Motor Spinning 2000 RPM

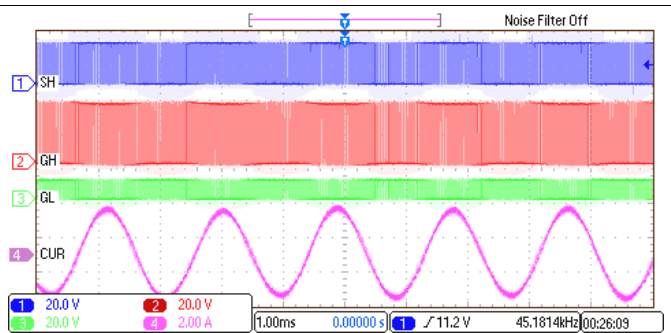

Figure 8. Motor Spinning 4000 RPM

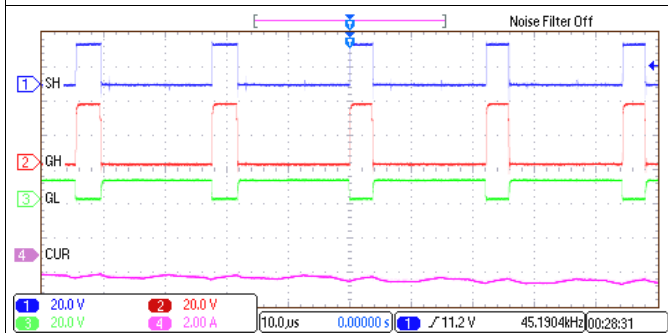

Figure 9. Gate Drive 20% Duty Cycle

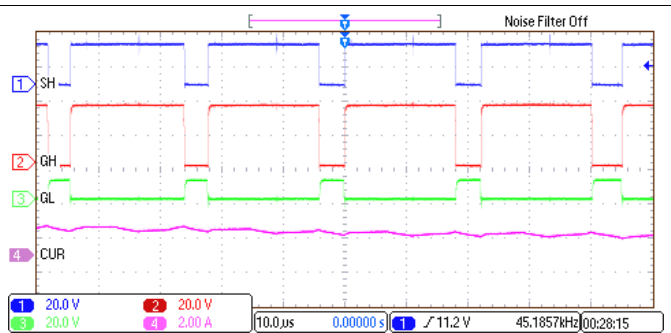

Figure 10. Gate Drive 80% Duty Cycle

9 Power Supply Recommendations

9.1 Bulk Capacitance

Having appropriate local bulk capacitance is an important factor in motor drive system design. It is generally beneficial to have more bulk capacitance, while the disadvantages are increased cost and physical size.

The amount of local capacitance needed depends on a variety of factors, including:

- The highest current required by the motor system
- The capacitance of the power supply and its ability to source or sink current
- The amount of parasitic inductance between the power supply and motor system
- The acceptable voltage ripple
- The type of motor used (brushed DC, brushless DC, stepper)
- The motor braking method

The inductance between the power supply and motor drive system will limit the rate current can change from the power supply. If the local bulk capacitance is too small, the system will respond to excessive current demands or dumps from the motor with a change in voltage. When adequate bulk capacitance is used, the motor voltage remains stable and high current can be quickly supplied.

The data sheet generally provides a recommended value, but system-level testing is required to determine the appropriate sized bulk capacitor.

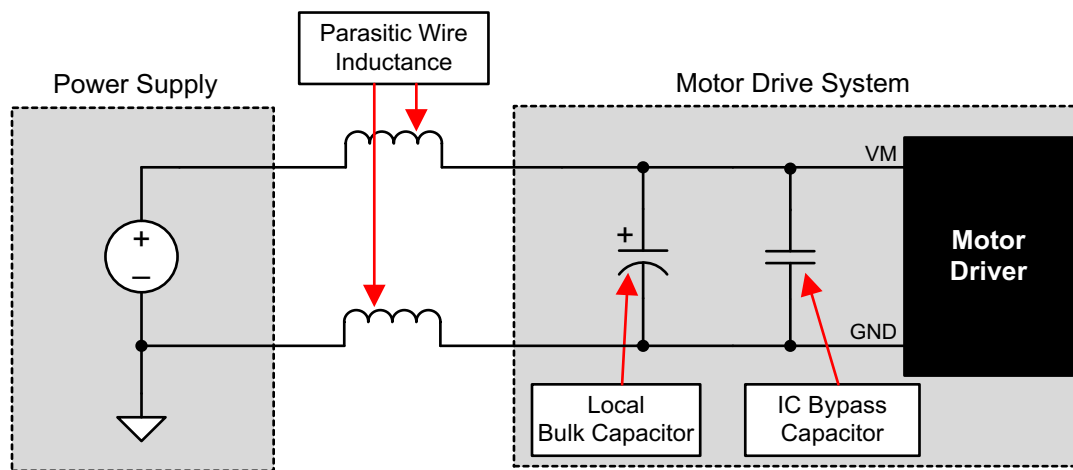

Figure 11. Example Setup of Motor Drive System With External Power Supply

The voltage rating for bulk capacitors should be higher than the operating voltage, to provide margin for cases when the motor transfers energy to the supply.

10 Layout

10.1 Layout Guidelines

Use these layout recommendations when designing a PCB for the DRV8302.

- The DRV8302 makes an electrical connection to GND through the PowerPAD. Always check to ensure that the PowerPAD has been properly soldered (See the application report, *PowerPAD™ Thermally Enhanced Package* application report, [SLMA002](#)).
- PVDD bypass capacitors should be placed close to their corresponding pins with a low impedance path to device GND (PowerPAD).
- GVDD bypass capacitor should be placed close its corresponding pin with a low impedance path to device GND (PowerPAD).
- AVDD and DVDD bypass capacitors should be placed close to their corresponding pins with a low impedance path to the AGND pin. It is preferable to make this connection on the same layer.
- AGND should be tied to device GND (PowerPAD) through a low impedance trace/copper fill.
- Add stitching vias to reduce the impedance of the GND path from the top to bottom side.
- Try to clear the space around and underneath the DRV8302 to allow for better heat spreading from the PowerPAD.

10.2 Layout Example

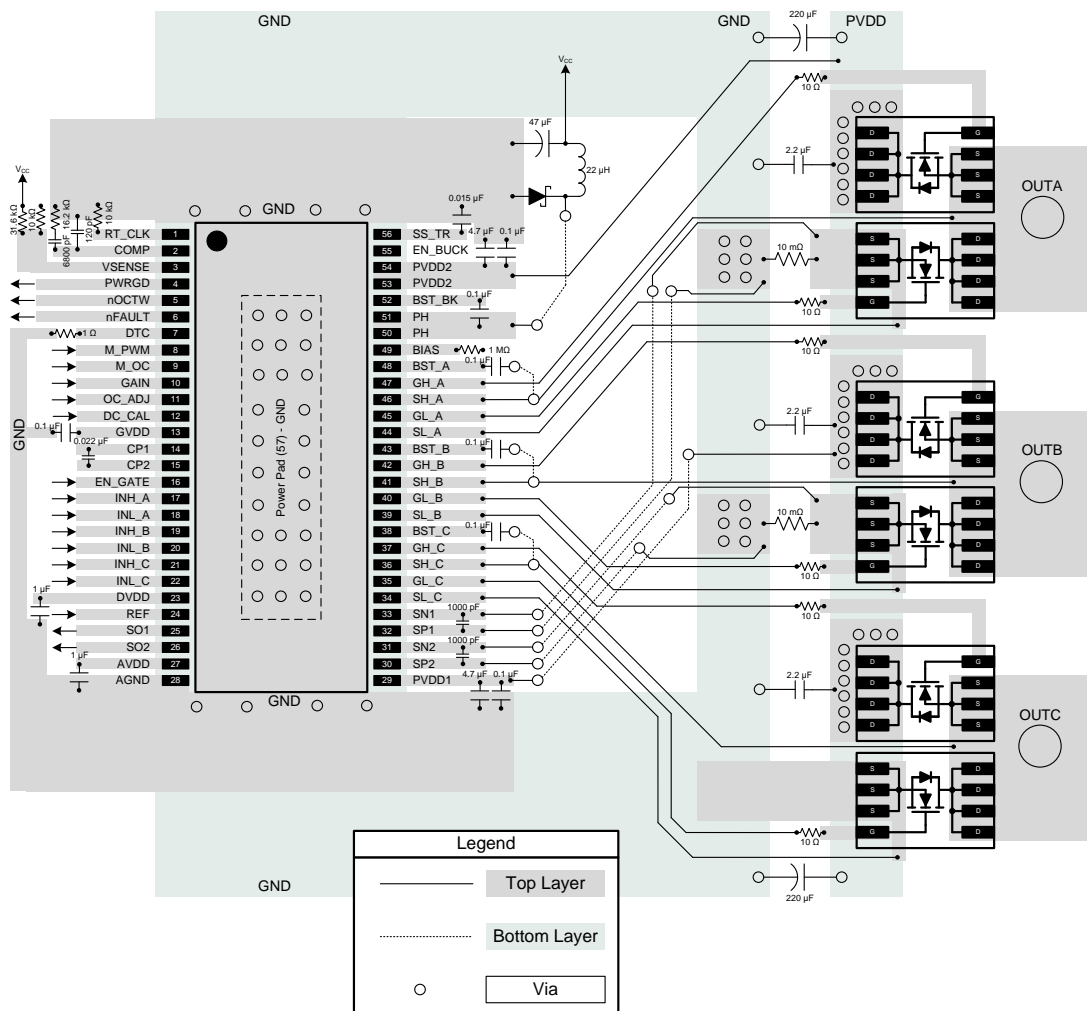

Figure 12. Top and Bottom Layer Layout Schematic

11 Device and Documentation Support

11.1 Documentation Support

11.1.1 Related Documentation

For related documentation, see the following:

- *PowerPAD Thermally Enhanced Package*, [SLMA002](#)
- *TPS54160 1.5-A, 60-V, Step-Down DC/DC Converter With Eco-mode™*, [SLVSB56](#)

11.2 Community Resources

The following links connect to TI community resources. Linked contents are provided "AS IS" by the respective contributors. They do not constitute TI specifications and do not necessarily reflect TI's views; see TI's [Terms of Use](#).

TI E2E™ Online Community *TI's Engineer-to-Engineer (E2E) Community*. Created to foster collaboration among engineers. At e2e.ti.com, you can ask questions, share knowledge, explore ideas and help solve problems with fellow engineers.

Design Support *TI's Design Support* Quickly find helpful E2E forums along with design support tools and contact information for technical support.

11.3 Trademarks

PowerPAD, E2E are trademarks of Texas Instruments. All other trademarks are the property of their respective owners.

11.4 Electrostatic Discharge Caution



These devices have limited built-in ESD protection. The leads should be shorted together or the device placed in conductive foam during storage or handling to prevent electrostatic damage to the MOS gates.

11.5 Glossary

[SLYZ022](#) — *TI Glossary*.

This glossary lists and explains terms, acronyms, and definitions.

12 Mechanical, Packaging, and Orderable Information

The following pages include mechanical, packaging, and orderable information. This information is the most current data available for the designated devices. This data is subject to change without notice and revision of this document. For browser-based versions of this data sheet, refer to the left-hand navigation.

PACKAGING INFORMATION

Orderable part number	Status (1)	Material type (2)	Package Pins	Package qty Carrier	RoHS (3)	Lead finish/ Ball material (4)	MSL rating/ Peak reflow (5)	Op temp (°C)	Part marking (6)
DRV8302DCA	Active	Production	HTSSOP (DCA) 56	35 TUBE	Yes	NIPDAU	Level-3-260C-168 HR	-40 to 125	DRV8302
DRV8302DCA.A	Active	Production	HTSSOP (DCA) 56	35 TUBE	Yes	NIPDAU	Level-3-260C-168 HR	-40 to 125	DRV8302
DRV8302DCA.B	Active	Production	HTSSOP (DCA) 56	35 TUBE	-	Call TI	Call TI	-40 to 125	
DRV8302DCAG4	Active	Production	HTSSOP (DCA) 56	35 TUBE	Yes	NIPDAU	Level-3-260C-168 HR	-40 to 125	DRV8302
DRV8302DCAG4.A	Active	Production	HTSSOP (DCA) 56	35 TUBE	Yes	NIPDAU	Level-3-260C-168 HR	-40 to 125	DRV8302
DRV8302DCAG4.B	Active	Production	HTSSOP (DCA) 56	35 TUBE	-	Call TI	Call TI	-40 to 125	
DRV8302DCAR	Active	Production	HTSSOP (DCA) 56	2000 LARGE T&R	Yes	NIPDAU	Level-3-260C-168 HR	-40 to 125	DRV8302
DRV8302DCAR.A	Active	Production	HTSSOP (DCA) 56	2000 LARGE T&R	Yes	NIPDAU	Level-3-260C-168 HR	-40 to 125	DRV8302
DRV8302DCAR.B	Active	Production	HTSSOP (DCA) 56	2000 LARGE T&R	-	Call TI	Call TI	-40 to 125	

(1) **Status:** For more details on status, see our [product life cycle](#).

(2) **Material type:** When designated, preproduction parts are prototypes/experimental devices, and are not yet approved or released for full production. Testing and final process, including without limitation quality assurance, reliability performance testing, and/or process qualification, may not yet be complete, and this item is subject to further changes or possible discontinuation. If available for ordering, purchases will be subject to an additional waiver at checkout, and are intended for early internal evaluation purposes only. These items are sold without warranties of any kind.

(3) **RoHS values:** Yes, No, RoHS Exempt. See the [TI RoHS Statement](#) for additional information and value definition.

(4) **Lead finish/Ball material:** Parts may have multiple material finish options. Finish options are separated by a vertical ruled line. Lead finish/Ball material values may wrap to two lines if the finish value exceeds the maximum column width.

(5) **MSL rating/Peak reflow:** The moisture sensitivity level ratings and peak solder (reflow) temperatures. In the event that a part has multiple moisture sensitivity ratings, only the lowest level per JEDEC standards is shown. Refer to the shipping label for the actual reflow temperature that will be used to mount the part to the printed circuit board.

(6) **Part marking:** There may be an additional marking, which relates to the logo, the lot trace code information, or the environmental category of the part.

Multiple part markings will be inside parentheses. Only one part marking contained in parentheses and separated by a "-" will appear on a part. If a line is indented then it is a continuation of the previous line and the two combined represent the entire part marking for that device.

Important Information and Disclaimer: The information provided on this page represents TI's knowledge and belief as of the date that it is provided. TI bases its knowledge and belief on information provided by third parties, and makes no representation or warranty as to the accuracy of such information. Efforts are underway to better integrate information from third parties. TI has taken and continues to take reasonable steps to provide representative

and accurate information but may not have conducted destructive testing or chemical analysis on incoming materials and chemicals. TI and TI suppliers consider certain information to be proprietary, and thus CAS numbers and other limited information may not be available for release.

In no event shall TI's liability arising out of such information exceed the total purchase price of the TI part(s) at issue in this document sold by TI to Customer on an annual basis.

TUBE

*All dimensions are nominal

Device	Package Name	Package Type	Pins	SPQ	L (mm)	W (mm)	T (μm)	B (mm)
DRV8302DCA	DCA	HTSSOP	56	35	530	11.89	3600	4.9
DRV8302DCA.A	DCA	HTSSOP	56	35	530	11.89	3600	4.9
DRV8302DCAG4	DCA	HTSSOP	56	35	530	11.89	3600	4.9
DRV8302DCAG4.A	DCA	HTSSOP	56	35	530	11.89	3600	4.9

GENERIC PACKAGE VIEW

DCA 56

PowerPAD™ TSSOP - 1.2 mm max height

8.1 x 14, 0.5 mm pitch

PLASTIC SMALL OUTLINE

This image is a representation of the package family, actual package may vary.
Refer to the product data sheet for package details.

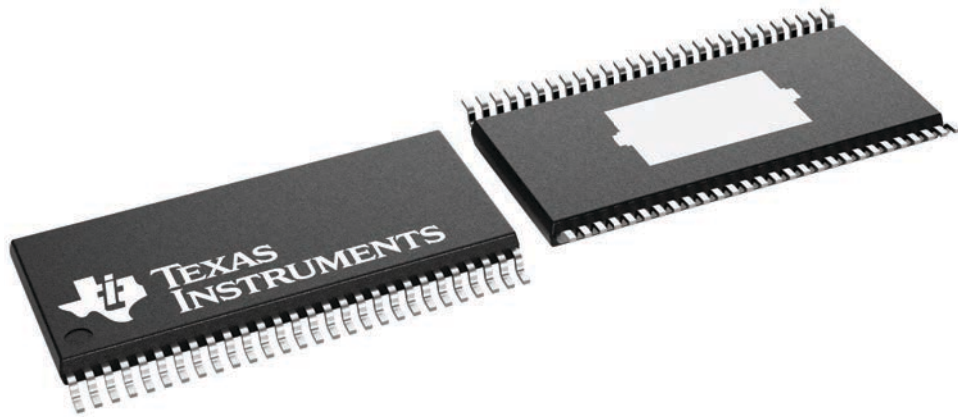

4231600/A

MECHANICAL DATA

DCA (R-PDSO-G56)

PowerPAD™ PLASTIC SMALL-OUTLINE

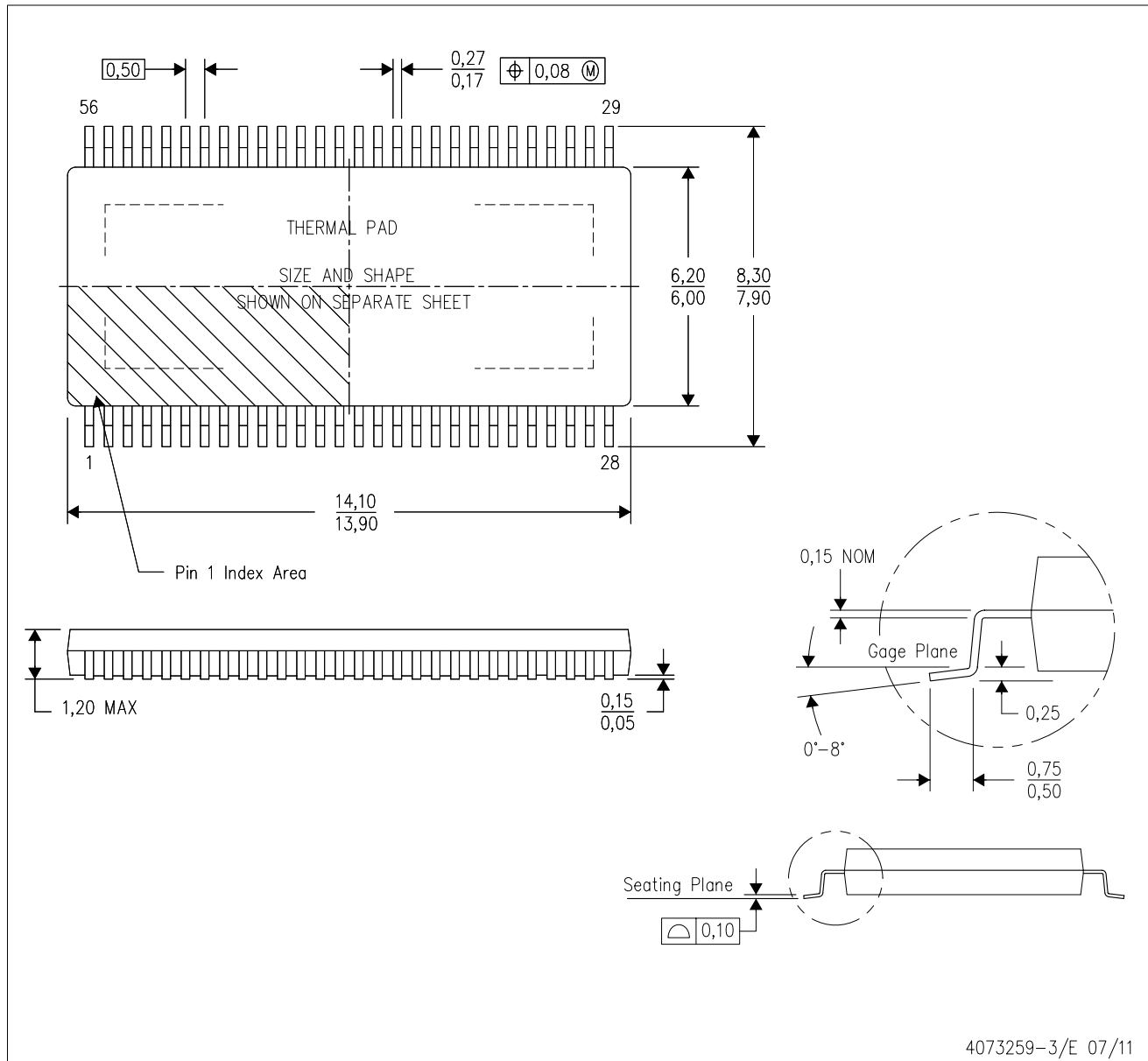

- NOTES:
- All linear dimensions are in millimeters. Dimensioning and tolerancing per ASME Y14.5M-1994.
 - This drawing is subject to change without notice.
 - Body dimensions do not include mold flash or protrusion not to exceed 0,15.
 - This package is designed to be soldered to a thermal pad on the board. Refer to Technical Brief, PowerPad Thermally Enhanced Package, Texas Instruments Literature No. SLMA002 for information regarding recommended board layout. This document is available at www.ti.com <<http://www.ti.com>>.
 - See the additional figure in the Product Data Sheet for details regarding the exposed thermal pad features and dimensions.
 - Falls within JEDEC MO-153

PowerPAD is a trademark of Texas Instruments.

THERMAL PAD MECHANICAL DATA

DCA (R-PDSO-G56)

PowerPAD™ PLASTIC SMALL OUTLINE

THERMAL INFORMATION

This PowerPAD™ package incorporates an exposed thermal pad that is designed to be attached to a printed circuit board (PCB). The thermal pad must be soldered directly to the PCB. After soldering, the PCB can be used as a heatsink. In addition, through the use of thermal vias, the thermal pad can be attached directly to the appropriate copper plane shown in the electrical schematic for the device, or alternatively, can be attached to a special heatsink structure designed into the PCB. This design optimizes the heat transfer from the integrated circuit (IC).

For additional information on the PowerPAD package and how to take advantage of its heat dissipating abilities, refer to Technical Brief, PowerPAD Thermally Enhanced Package, Texas Instruments Literature No. SLMA002 and Application Brief, PowerPAD Made Easy, Texas Instruments Literature No. SLMA004. Both documents are available at www.ti.com.

The exposed thermal pad dimensions for this package are shown in the following illustration.

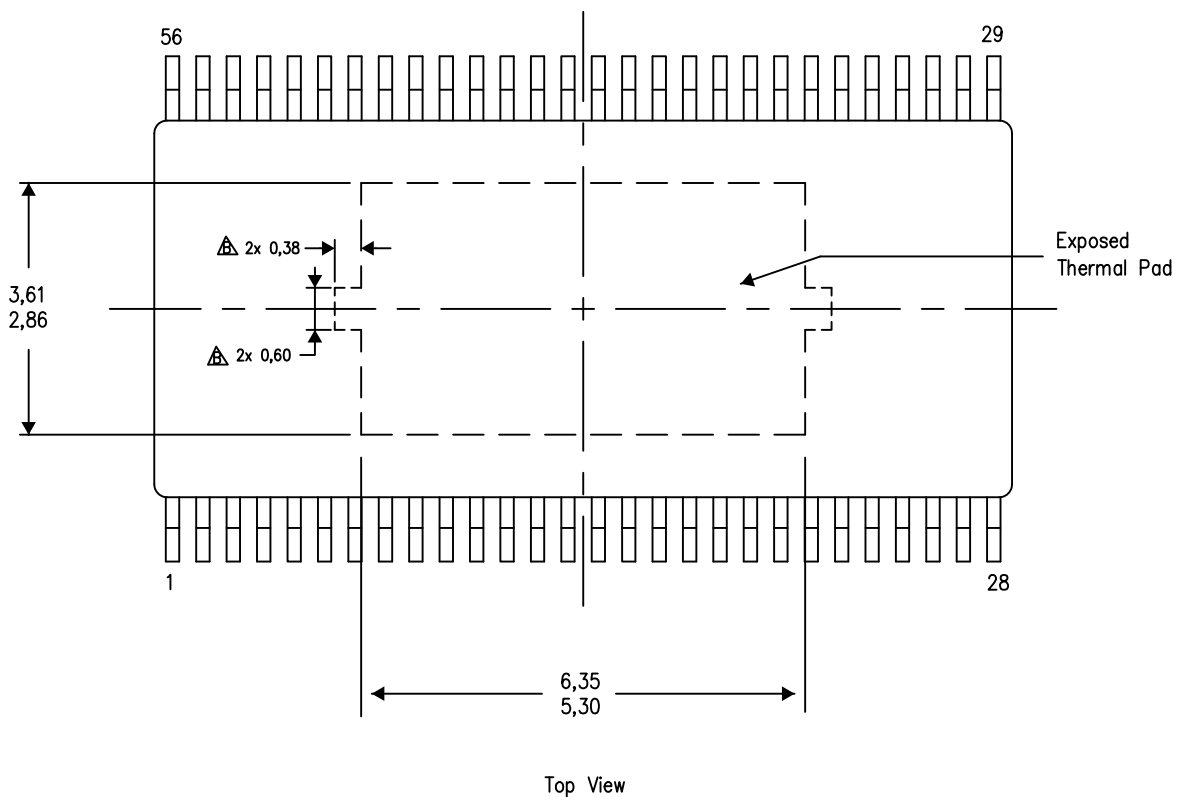

Exposed Thermal Pad Dimensions

4206320-15/S 11/14

NOTES: A. All linear dimensions are in millimeters

- △ Keep-out features are identified to prevent board routing interference. These exposed metal features may vary within the identified area or completely absent on some devices.

PowerPAD is a trademark of Texas Instruments.

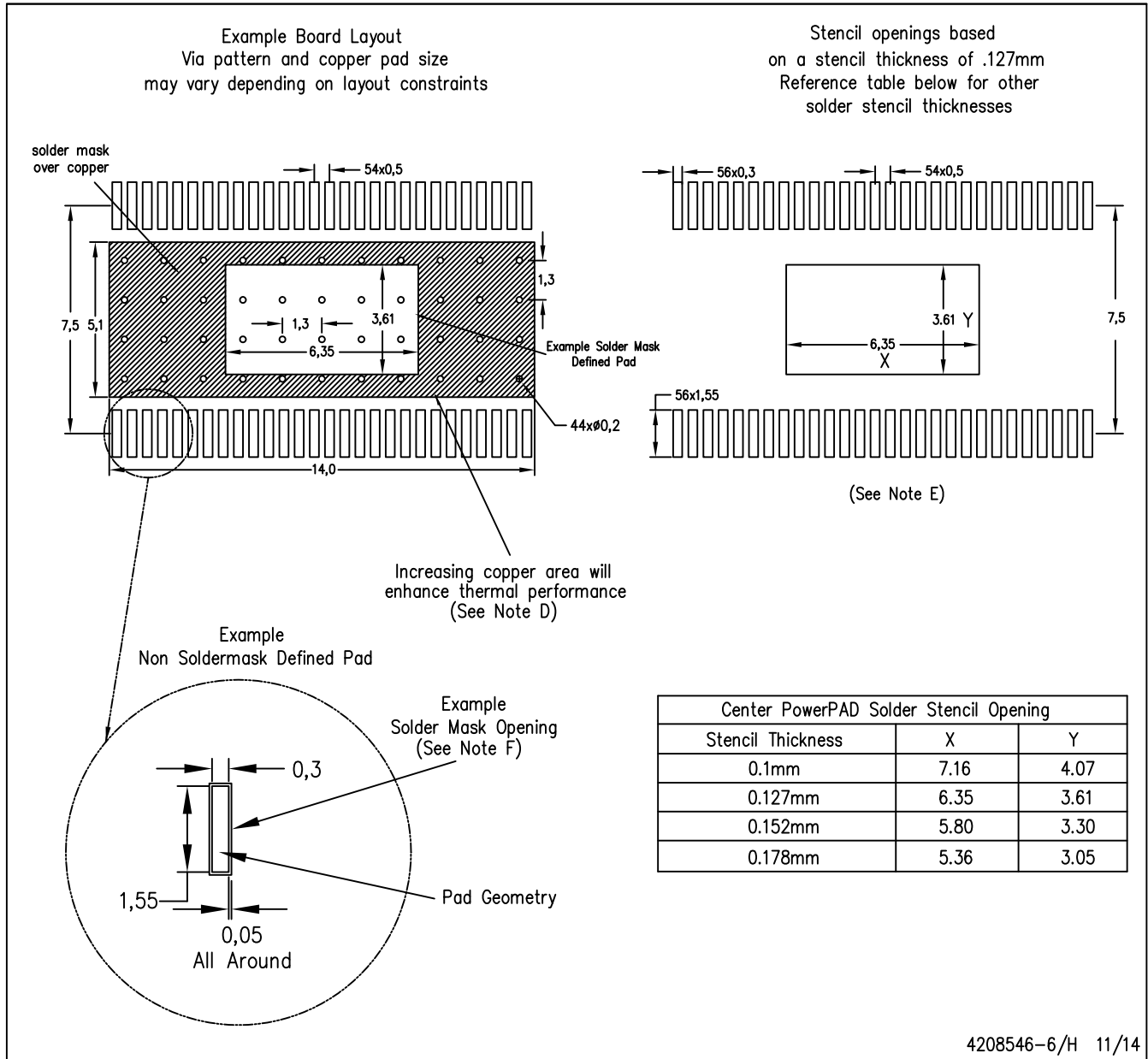

- NOTES:
- A. All linear dimensions are in millimeters.
 - B. This drawing is subject to change without notice.
 - C. Customers should place a note on the circuit board fabrication drawing not to alter the center solder mask defined pad.
 - D. This package is designed to be soldered to a thermal pad on the board. Refer to Technical Brief, PowerPAD Thermally Enhanced Package, Texas Instruments Literature No. SLMA002, SLMA004, and also the Product Data Sheets for specific thermal information, via requirements, and recommended board layout. These documents are available at www.ti.com <<http://www.ti.com>>. Publication IPC-7351 is recommended for alternate designs.
 - E. Laser cutting apertures with trapezoidal walls and also rounding corners will offer better paste release. Customers should contact their board assembly site for stencil design recommendations. Example stencil design based on a 50% volumetric metal load solder paste. Refer to IPC-7525 for other stencil recommendations.
 - F. Customers should contact their board fabrication site for solder mask tolerances between and around signal pads.

IMPORTANT NOTICE AND DISCLAIMER

TI PROVIDES TECHNICAL AND RELIABILITY DATA (INCLUDING DATASHEETS), DESIGN RESOURCES (INCLUDING REFERENCE DESIGNS), APPLICATION OR OTHER DESIGN ADVICE, WEB TOOLS, SAFETY INFORMATION, AND OTHER RESOURCES "AS IS" AND WITH ALL FAULTS, AND DISCLAIMS ALL WARRANTIES, EXPRESS AND IMPLIED, INCLUDING WITHOUT LIMITATION ANY IMPLIED WARRANTIES OF MERCHANTABILITY, FITNESS FOR A PARTICULAR PURPOSE OR NON-INFRINGEMENT OF THIRD PARTY INTELLECTUAL PROPERTY RIGHTS.

These resources are intended for skilled developers designing with TI products. You are solely responsible for (1) selecting the appropriate TI products for your application, (2) designing, validating and testing your application, and (3) ensuring your application meets applicable standards, and any other safety, security, regulatory or other requirements.

These resources are subject to change without notice. TI grants you permission to use these resources only for development of an application that uses the TI products described in the resource. Other reproduction and display of these resources is prohibited. No license is granted to any other TI intellectual property right or to any third party intellectual property right. TI disclaims responsibility for, and you fully indemnify TI and its representatives against any claims, damages, costs, losses, and liabilities arising out of your use of these resources.

TI's products are provided subject to [TI's Terms of Sale](#), [TI's General Quality Guidelines](#), or other applicable terms available either on ti.com or provided in conjunction with such TI products. TI's provision of these resources does not expand or otherwise alter TI's applicable warranties or warranty disclaimers for TI products. Unless TI explicitly designates a product as custom or customer-specified, TI products are standard, catalog, general purpose devices.

TI objects to and rejects any additional or different terms you may propose.

Copyright © 2025, Texas Instruments Incorporated

Last updated 10/2025