

48V BLDC Drives for Industrial and Automotive Applications - Enabling Integrated Motor Designs



Manu Balakrishnan, Nihal Palankar, Pratyush Saxena

ABSTRACT

Brushless DC (BLDC) motors are popular in industrial and automotive applications for best system efficiency, longer life and compact design. These applications use a wide range of low voltage input supplies like 5V, 12V, 24V, 36V, 48V DC in industrial and 12V, 24V, 48V in automotive applications. The recent trend of wider adaption to 48V helps in reduction of overall system cost, efficiency improvement while still enabling low-voltage architecture, minimizing safety concerns. Applications like robotics, humanoids, BLDC motor modules, and automotive systems often require integration of electronics in to the motor body for smart motor designs to reduce cabling, EMI and system design complexities.

This application note introduces TI's latest 3-phase integrated FET BLDC driver DRV8376 (70V, 4.5A peak), and describes how DRV8376 helps to design compact BLDC drives up to 48V applications.

Table of Contents

1 Introduction	2
2 Application Overview	2
2.1 Automotive 48V HVAC Valves and Actuators.....	2
2.2 Building HVAC Valves and Actuators.....	2
2.3 Industrial Application with 48V Supply.....	3
3 Integrated FET 3-Phase Motor Driver DRV8376 for 48V Applications	3
4 DRV8376 for High Performance System Design	5
4.1 Enabling 48V BLDC Motor Drive Applications.....	5
4.2 Compact Design with High Level Integration.....	5
4.3 Increased Power Delivery and Efficiency.....	5
4.4 Increased Creepage and Clearance.....	6
4.5 Improved Precision in Motor Control.....	6
4.6 Integrated Protection.....	6
4.7 EMI Optimization.....	7
5 Summary	8
6 References	8

Trademarks

All trademarks are the property of their respective owners.

1 Introduction

Traditionally, the 4-wheeler automotive systems use 12V supply across body, ADAS, infotainment subsystems. However, the adoption of 48V is increasing, driven from improved efficiency, lower system cost, savings in copper wiring, reduction in overall size and weight and enable lower emissions while still being in the low voltage (48V) design, without the need of stringent high voltage safety requirements. The 48V supply is widely used in industrial applications like factory automation, robotics, medical, server and telecom applications. The residential and commercial Heating, Ventilation and Air Conditioning (HVAC) systems use 24V AC supply for light loads like thermostats, valves etc. These applications typically consist of Microcontroller Units (MCUs) with BLDC motor control algorithm, MOSFETs for H-bridges, gate drivers for controlling the turn-on/turn-off of the MOSFETs, sensing circuitry for real-time sensing of motor phase currents or rotor position, LDOs and system-level protection functions. These designs often need compact and precise BLDC drives to enable integration of electronics into the motor, reducing system cost and to achieve higher system efficiency.

2 Application Overview

2.1 Automotive 48V HVAC Valves and Actuators

Figure 2-1 shows a simplified block diagram of a HVAC valve or actuator driven from 48V supply using a BLDC motor drive. The position of the valve is adjusted based on the command from the Electronic control unit (ECU). The 48V adaption in automotive systems reduces the current requirement for same motor power that results in

- Reduction in copper wiring
- Increase in power delivery
- Increase in system efficiency
- Reduction of cost and weight

The new smart motors in automotive systems need compact designs to integrate electronics to motor and that is easier with lower current designs at 48V.

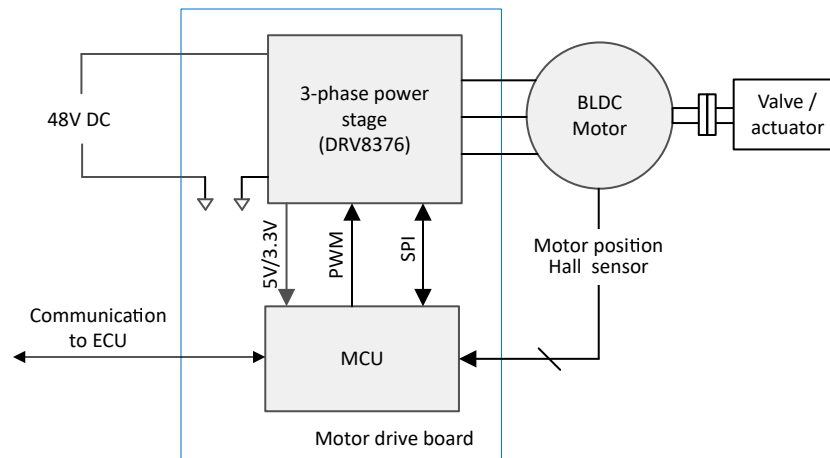

Figure 2-1. BLDC Motor Drives in Automotive HVAC Systems Application Diagram

2.2 Building HVAC Valves and Actuators

Valves and actuators are located in HVAC systems to control the air flow in the air handling units and zonal controller units for best cooling/heating regulation. The system designs often require precise motor control to control the position of valves or actuators as per the command from the HVAC controller or thermostat. Figure 2-2 shows a typical block diagram of the system. The supply is typically driven from a 24V AC supply, giving a rectified voltage of 34V (peak voltage up to 42V with 20% tolerance on 24V AC line voltage).

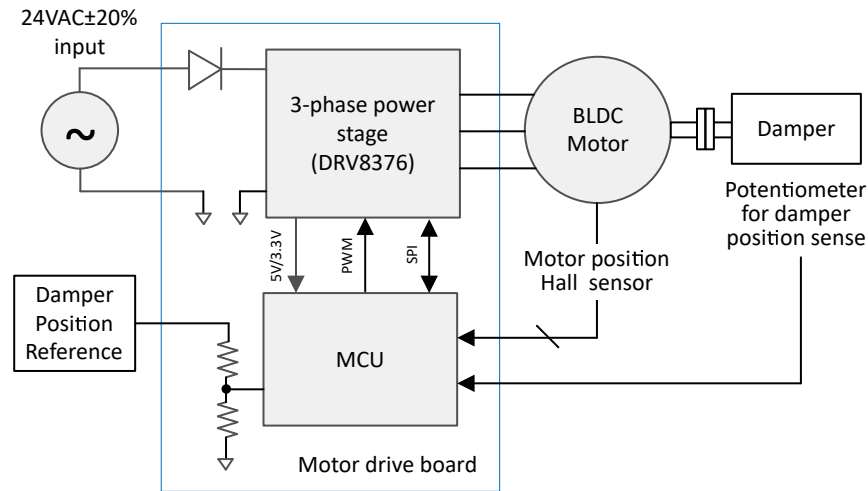

Figure 2-2. BLDC Motor Drives in Building HVAC Systems Application Diagram

2.3 Industrial Application with 48V Supply

2.3.1 Robotics and Humanoids

The robotics and humanoid designs often need integration of electronics into the motor to reduce wiring and to realize compact design. The 48V supply reduces the current requirement for same power and further single chip drivers makes the design compact. The designs also need precise motor control and that need motor drivers with low dead time and propagation delay.

2.3.2 Server and Telecom

The telecom systems traditionally use 48V supplies for achieving better efficiency in power transmission. The server cooling systems from traditional 12V supply to 48V supply is also getting popular due to reduced power distribution losses, better system efficiency and compact design.

3 Integrated FET 3-Phase Motor Driver DRV8376 for 48V Applications

The DRV8376 is a single-chip 3-phase power stage for driving BLDC motors from 4.5V to 65V. The DRV8376 integrates three 1/2H bridges with 70V absolute maximum voltage capability with optimized switching and a low $R_{DS(ON)}$ (200mΩ per FET) MOSFET to enable high power drive capability. Motor current is sensed using a shunt-less integrated current sense circuit, eliminating the need for external sense resistors and current sense amplifiers. Power management features with integrated LDOs to generate the necessary voltage rails of 3.3V (AVDD) and 5V (GVDD) that can also be used to power external circuits.

Figure 3-1 shows the simplified application schematic of DRV8376.

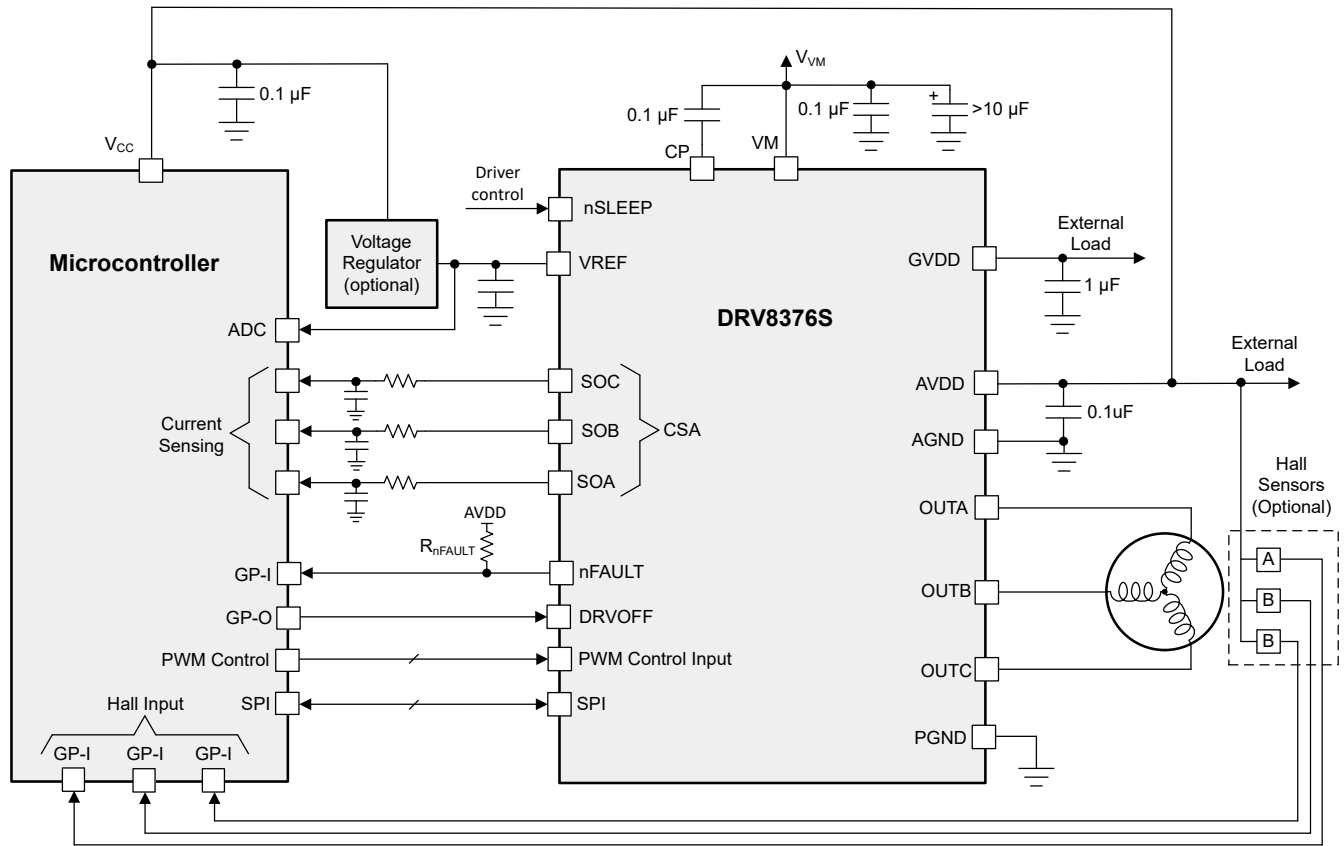

Figure 3-1. DRV8376 Simplified Application Schematic

4 DRV8376 for High Performance System Design

4.1 Enabling 48V BLDC Motor Drive Applications

The DRV8376 comes with a maximum operating voltage rating of 65V and absolute maximum voltage rating of 70V. The high voltage rating makes DRV8376 an excellent choice for 48V industrial and automotive applications, those typically having a maximum voltage tolerance of up to 60V. The device comes with integrated over voltage protection and that can be leveraged to place all the MOSFETs in to Hi-Z in the event of a DC voltage more than the over voltage protection threshold.

4.2 Compact Design with High Level Integration

The device integrates six N-channel MOSFETs with integrated gate driver. The high side gate driver uses charge-pump based power supply with one integrated capacitor, that need only one external capacitor. The integrated shunt less current sense, LDOs, and multi-level protection eliminates the need of external components. All integration available in a 6x4mm package. [Table 4-1](#) lists the integration in DRV8376 compared to a discrete approach illustrating the saving of more than 40 external components.

Table 4-1. Integration of DRV8376 Compared to Discrete Approach

Integration in DRV8376	Number of components in a discrete implementation
Six N-channel MOSFETs	Six N-channel discrete MOSFETs
3-phase gate driver with integrated gate current control options	One 3-phase gate driver, 12 resistors (six gate resistors & six gate-source resistors)
One integrated charge pump capacitor and one external capacitor	Two external capacitors
Three shunt-less current sense	3-shunt resistors, 3 current sense amplifiers and more than 12 resistors for gain configuration
3.3V and 5V LDO	1 or 2 external LDO
Multilevel protection	Multiple passive components and comparators

4.3 Increased Power Delivery and Efficiency

The DRV8376 integrates switching loss optimized gate drivers which minimize the voltage-current (VI) overlap loss during switching by increased slew rate (1.1V/ns typical at 24V). A small dead time enables lower diode conduction losses. The integrated shunt-less current sense eliminates the losses in an external shunt resistor. A smaller dead time and propagation delay enables best utilization of DC bus voltage and achieving the same power delivery for lower motor current, that further reduces motor copper losses.

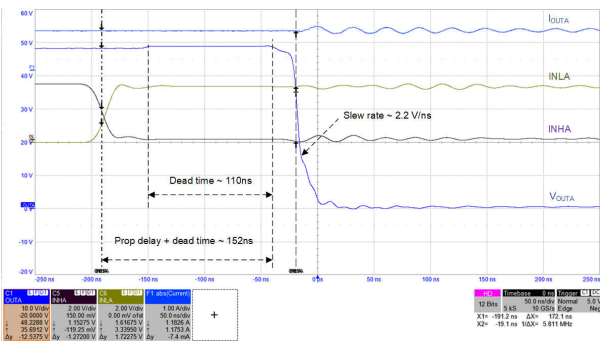

Figure 4-1. DRV8376 Voltage Falling Edge Slew Rate

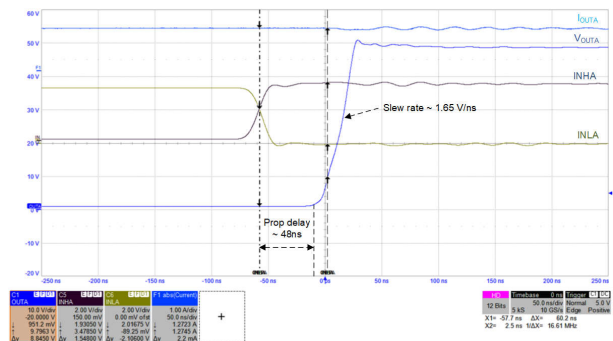

Figure 4-2. DRV8376 Voltage Rising Edge Slew Rate

[Figure 4-1](#) shows the falling edge slew rate of DRV8376 at 48V DC supply and 1A load current (current flows into the phase node from the motor winding). [Figure 4-2](#) shows the rising edge slew rate of DRV8376 at 48V DC supply and 1A load current (current flows in to the phase node into the motor winding). The observed propagation delay is less than 50ns and dead time is approximately 110ns. Very low propagation delay and dead times helps in minimizing the distortion in motor current, enable accurate average motor current sensing and improves the available voltage to the motor.

4.4 Increased Creepage and Clearance

The DRV8376 is available in 6x4 mm QFN package with a clearance of 0.6mm between the pins where a voltage up to VM is expected. For example, at VM = 48V, the device has increased clearance between those high voltage pins (including, VM, OUTx, CP to GND). [Figure 4-3](#) indicates the pins with 0.6mm clearance.

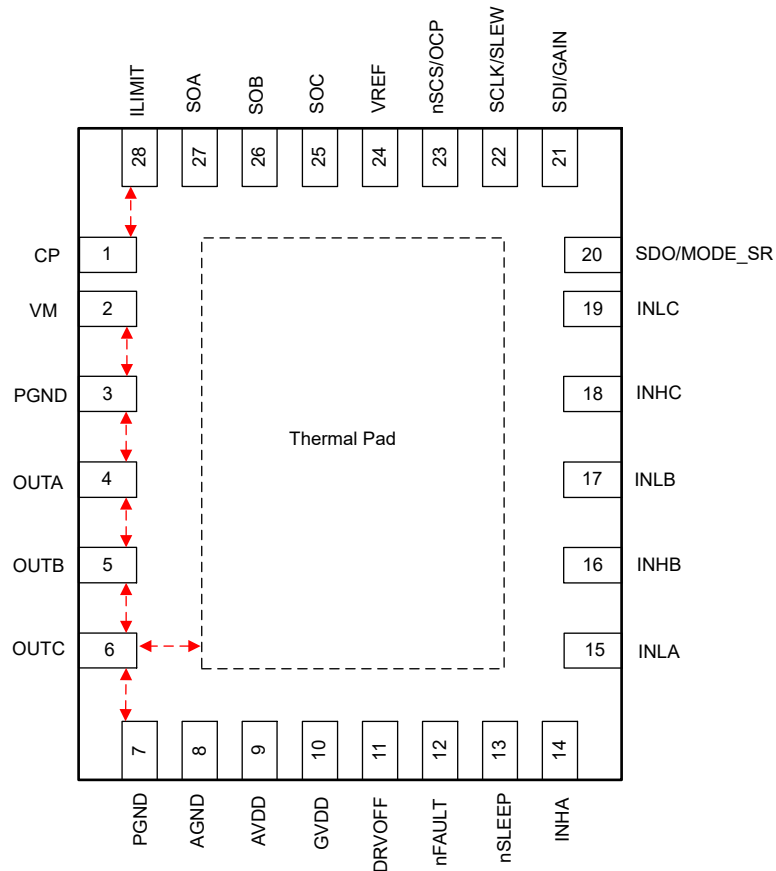

Figure 4-3. DRV8376 Package Showing Increased Clearance

4.5 Improved Precision in Motor Control

The DRV8376 comes with optimized switching to minimize the dead time to less than 150ns and propagation delay to less than 100ns. The low dead time, propagation delay and propagation delay mismatch are critical in minimizing the current distortion in motor to get precise and quiet motor control. In HVAC applications, precise positioning of the valves requires precise motor control for best cooling/heating experience.

4.6 Integrated Protection

DRV8376 integrates a wide range of protections for a reliable system design that includes:

- Over current Protection (OCP) against Short circuit events
- Cycle-by-cycle current limit (ILIMIT) to eliminate overheating and stress during overload conditions
- Configurable over voltage protection (OVP)
- Supply and charge pump under voltage protection to eliminate undesired operation.
- Over temperature warning and shutdown (OTW and OTSD)

The device offers an SPI option for detailed fault diagnostics and control. [Figure 4-4](#) shows the over current protection of DRV8376 during a short-circuit event at 48V.

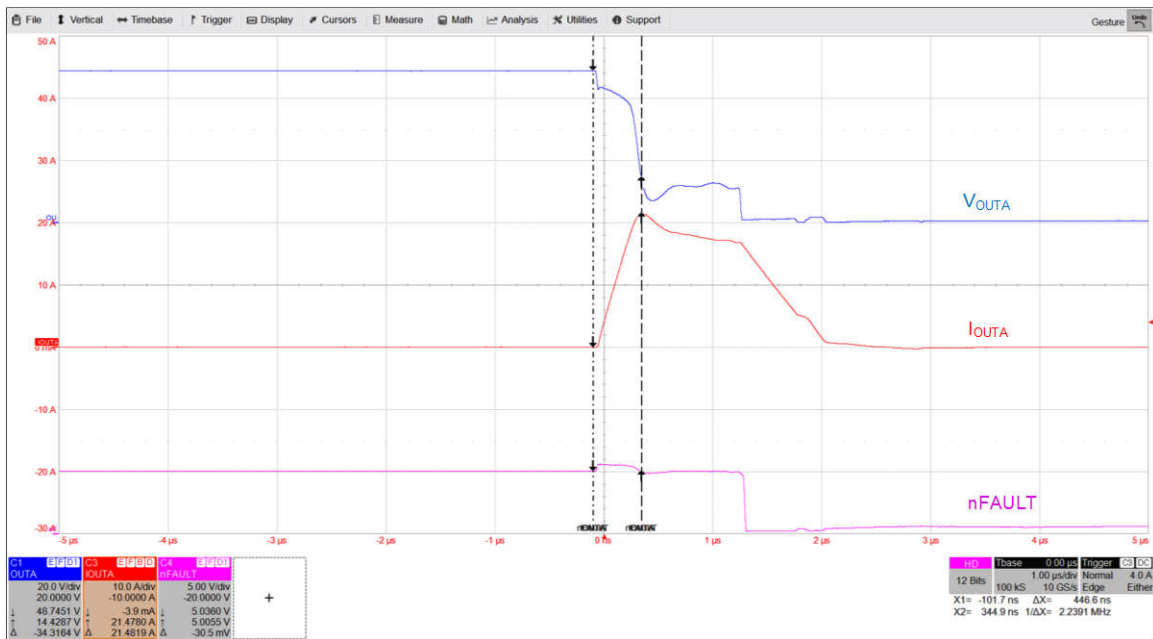

Figure 4-4. Over Current Protection of DRV8376 During a Short-Circuit Event at 48V

4.7 EMI Optimization

DRV8376 comes with an adjustable OUTx voltage switching slew rate (dv/dt) setting. An adjustable gate-drive current control to the MOSFETs of half-bridges is implemented to achieve the slew rate control.

The MOSFET V_{DS} slew rates are a critical factor for optimizing radiated emissions, and switching voltage transients related to parasitic.

The slew rate of each half-bridge can be adjusted by the SLEW pin in hardware device variant or by using the SLEW bits in SPI device variant. Each half-bridge can be selected to either of a slew rate setting of 1.1V/ns, 0.5V/ns, 0.25V/ns or 0.05V/ns. The slew rate is calculated by the rise time and fall time of the voltage on OUTx pin.

5 Summary

The adoption of 48V is increasing in automotive and industrial applications, driven from improved efficiency, lower system cost, savings in copper wiring and reduction in overall size and weight and enable low emissions. TI's 3-phase integrated MOSFET motor driver DRV8376 rated for 70V absolute maximum voltage rating enables electronics integration to motor with high level of integration and eases the design for 48V BLDC motor drives with reduced cabling, optimized EMI, and integrated protections.

6 References

- Texas Instruments, [DRV8376 Three-Phase Integrated FET Motor Driver](#), data sheet.

IMPORTANT NOTICE AND DISCLAIMER

TI PROVIDES TECHNICAL AND RELIABILITY DATA (INCLUDING DATA SHEETS), DESIGN RESOURCES (INCLUDING REFERENCE DESIGNS), APPLICATION OR OTHER DESIGN ADVICE, WEB TOOLS, SAFETY INFORMATION, AND OTHER RESOURCES "AS IS" AND WITH ALL FAULTS, AND DISCLAIMS ALL WARRANTIES, EXPRESS AND IMPLIED, INCLUDING WITHOUT LIMITATION ANY IMPLIED WARRANTIES OF MERCHANTABILITY, FITNESS FOR A PARTICULAR PURPOSE OR NON-INFRINGEMENT OF THIRD PARTY INTELLECTUAL PROPERTY RIGHTS.

These resources are intended for skilled developers designing with TI products. You are solely responsible for (1) selecting the appropriate TI products for your application, (2) designing, validating and testing your application, and (3) ensuring your application meets applicable standards, and any other safety, security, regulatory or other requirements.

These resources are subject to change without notice. TI grants you permission to use these resources only for development of an application that uses the TI products described in the resource. Other reproduction and display of these resources is prohibited. No license is granted to any other TI intellectual property right or to any third party intellectual property right. TI disclaims responsibility for, and you will fully indemnify TI and its representatives against, any claims, damages, costs, losses, and liabilities arising out of your use of these resources.

TI's products are provided subject to [TI's Terms of Sale](#) or other applicable terms available either on [ti.com](#) or provided in conjunction with such TI products. TI's provision of these resources does not expand or otherwise alter TI's applicable warranties or warranty disclaimers for TI products.

TI objects to and rejects any additional or different terms you may have proposed.

Mailing Address: Texas Instruments, Post Office Box 655303, Dallas, Texas 75265

Copyright © 2025, Texas Instruments Incorporated