

TRSF3232E ±15kV IEC ESD 保護機能搭載、小型パッケージの 3V~5.5V 2 チャネル RS-232 1Mbit/s ラインドライバ/レシーバ

1 特長

- 3V~5.5V の V_{CC} 電源で動作
- 最大 1Mbit/s で動作
- 低い消費電流: 300 μ A (標準値)
- 外付けコンデンサ: 4 × 0.1 μ F
- 3.3V 電源で 5V ロジック入力を許容
- JEDEC 78、Class II 準拠で 100mA 超のラッチアップ性能
- RS-232 ピンの ESD 保護
 - ±15kV 人体モデル (HBM)
 - ±15kV IEC 61000-4-2 気中放電
 - ±8kV IEC 61000-4-2 接触放電
- ニアチップ スケール QFN (3mm x 3mm) パッケージで提供 (SOIC-16 より 85% 小型)

2 アプリケーション

- 産業用 PC
- 有線ネットワーク
- データ・センターおよびエンタープライズ・コンピューティング
- バッテリー駆動システム
- PDA
- ノートブック PC
- パームトップ PC
- ハンドヘルド機器

3 概要

TRSF3232E は 2 つのラインドライバ、2 つのラインレシーバ、1 つのデュアル チャージポンプ回路で構成されており、ピン間 (シリアルポート接続ピン、GND を含む) に ±15kV の ESD 保護機能を備えています。このデバイスは、非同期通信コントローラとシリアルポートコネクタの間の電氣的インターフェイスとして機能します。チャージポンプと 4 つの小さな外付けコンデンサにより、3V~5.5V の単一電源で動作できます。TRSF3232E は最大 1Mbit/s のデータ信号速度、14V/ μ s~150V/ μ s のドライバ出力スルーレートで動作します。

パッケージ情報

部品番号	パッケージ (1)	パッケージサイズ (2)
TRSF3232E	D (SOIC)	9.9 mm × 6mm
	DB (SSOP)	6.2 mm × 7.8mm
	DW (SOIC)	10.3 mm × 10.3mm
	PW (TSSOP)	5 mm × 6.4mm
	RGT (VQFN)	3 mm × 3mm
	SOT-23-THN (DYY) (16)	4.2mm × 2mm

- (1) 詳細については、[セクション 11](#) を参照してください。
- (2) パッケージサイズ (長さ × 幅) は公称値で、該当する場合はピンも含まれます。

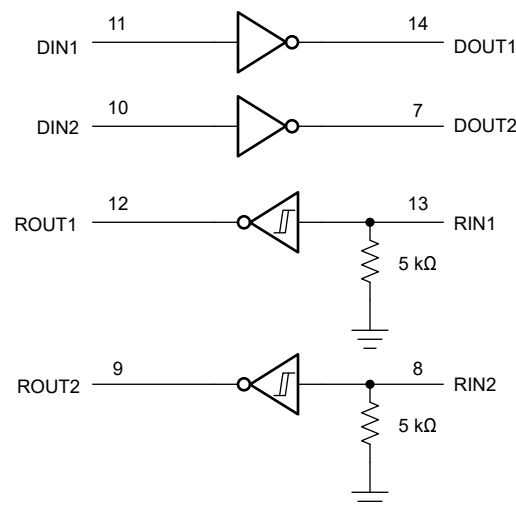

論理図 (正論理)



Table of Contents

1 特長	1	7.1 Overview.....	10
2 アプリケーション	1	7.2 Functional Block Diagram.....	10
3 概要	1	7.3 Feature Description.....	10
4 Pin Configuration and Functions	3	7.4 Device Functional Modes.....	11
5 Specifications	4	8 Application and Implementation	12
5.1 Absolute Maximum Ratings.....	4	8.1 Application Information.....	12
5.2 ESD Ratings.....	4	8.2 Typical Application.....	12
5.3 ESD Protection, Driver.....	4	8.3 Power Supply Recommendations.....	13
5.4 ESD Protection, Receiver.....	4	8.4 Layout.....	13
5.5 Recommended Operating Conditions.....	5	9 Device and Documentation Support	15
5.6 Thermal Information.....	5	9.1 ドキュメントの更新通知を受け取る方法.....	15
5.7 Electrical Characteristics.....	5	9.2 サポート・リソース.....	15
5.8 Electrical Characteristics, Driver.....	6	9.3 商標.....	15
5.9 Electrical Characteristics, Receiver.....	6	9.4 静電気放電に関する注意事項.....	15
5.10 Switching Characteristics, Driver.....	7	9.5 用語集.....	15
5.11 Switching Characteristics, Receiver.....	7	10 Revision History	15
5.12 Typical Characteristics.....	8	11 メカニカル、パッケージ、および注文情報	16
6 Parameter Measurement Information	9		
7 Detailed Description	10		

4 Pin Configuration and Functions



図 4-1. D, DB, DW, PW or DYY Package
16-Pin SSOP, TSSOP, or SOT-23-THN
(Top View)



図 4-2. RGT, VQFN Package (Top View)

表 4-1. Pin Functions

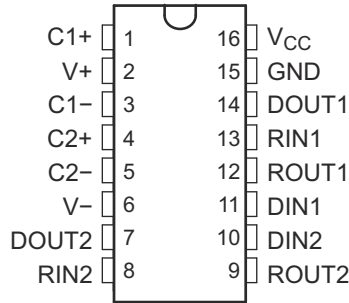
NAME	PIN		TYPE ⁽¹⁾	DESCRIPTION
	D, DB, DW, PW or DYY	RGT		
C1+	1	16	-	Positive lead of C1 capacitor
V+	2	15	O	Positive charge pump output for storage capacitor only
C1-	3	1	-	Negative lead of C1 capacitor
C2+	4	2	-	Positive lead of C2 capacitor
C2-	5	3	-	Negative lead of C2 capacitor
V-	6	4	O	Negative charge pump output for storage capacitor only
DOUT2	7	5	O	RS232 line data output (to remote RS232 system)
RIN2	8	6	I	RS232 line data input (from remote RS232 system)
ROUT2	9	7	O	Logic data output (to UART)
DIN2	10	8	I	Logic data input (from UART)
DIN1	11	9	I	Logic data input (from UART)
ROUT1	12	10	O	Logic data output (to UART)
RIN1	13	11	I	RS232 line data input (from remote RS232 system)
DOUT1	14	12	O	RS232 line data output (to remote RS232 system)
GRD	15	13	-	Ground
V _{CC}	16	14	-	Supply Voltage, Connect to external 3-V to 5.5-V power supply
Thermal Pad	-	Thermal Pad	-	Exposed thermal pad. Can be connected to GND or left floating.

(1) Signal Types: I = Input, O = Output, I/O = Input or Output.

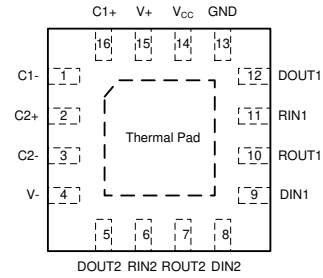
5 Specifications

5.1 Absolute Maximum Ratings

over operating free-air temperature range (unless otherwise noted) see note (1)

		MIN	MAX	UNIT	
V _{CC}	Supply voltage range ⁽²⁾	-0.3	6	V	
V+	Positive-output supply voltage range ⁽²⁾	-0.3	7	V	
V-	Negative-output supply voltage range ⁽²⁾	0.3	-7	V	
V+ – V-	Supply voltage difference ⁽²⁾		13	V	
V _I	Input voltage range	Drivers	-0.3	6	V
		Receivers	-25	25	
V _O	Output voltage range	Drivers	-13.2	13.2	V
		Receivers	-0.3	V _{CC} + 0.3	
T _J	Operating virtual junction temperature		150	°C	
T _{stg}	Storage temperature range	-65	150	°C	

- (1) Stresses beyond those listed under "absolute maximum ratings" may cause permanent damage to the device. These are stress ratings only, and functional operation of the device at these or any other conditions beyond those indicated under "recommended operating conditions" is not implied. Exposure to absolute-maximum-rated conditions for extended periods may affect device reliability.
- (2) All voltages are with respect to network GND.

5.2 ESD Ratings

		VALUE	UNIT	
V _(ESD)	Electrostatic discharge	Human-body model (HBM), per ANSI/ESDA/JEDEC JS-001 ¹ .	±3000	V
		Charged-device model (CDM), per JEDEC specification JESD22-C101 ²	±1500	

5.3 ESD Protection, Driver

PIN NAME	TEST CONDITIONS	TYP	UNIT
DOUT1, DOUT2 ⁽²⁾	Human-body model (HBM)	±15	kV
	IEC 61000-4-2 Air-Gap Discharge ⁽¹⁾	±15	
	IEC 61000-4-2 Contact Discharge ⁽¹⁾	±8	

- (1) For RGT, D and PW packages only: A minimum of 1-μF capacitor is needed between V_{CC} and GND to meet the specified IEC ESD level.
- (2) For optimized IEC ESD performance for DYY package, the recommendation is to have series resistor (≥ 50Ω), on all logic inputs directly connected to power or ground, to minimize the transient currents going into or out of the logic pins.

5.4 ESD Protection, Receiver

PIN NAME	TEST CONDITIONS	TYP	UNIT
RIN1, RIN2 ⁽²⁾	HBM	±15	kV
	IEC 61000-4-2 Air-Gap Discharge ⁽¹⁾	±15	
	IEC 61000-4-2 Contact Discharge ⁽¹⁾	±8	

- (1) For RGT, D and PW packages only: A minimum of 1-μF capacitor is needed between V_{CC} and GND to meet the specified IEC ESD level.
- (2) For optimized IEC ESD performance for DYY package, the recommendation is to have series resistor (≥ 50Ω), on all logic inputs directly connected to power or ground, to minimize the transient currents going into or out of the logic pins.

5.5 Recommended Operating Conditions

See note ⁽¹⁾

			MIN	NOM	MAX	UNIT
Supply voltage		$V_{CC} = 3.3\text{ V}$	3	3.3	3.6	V
		$V_{CC} = 5\text{ V}$	4.5	5	5.5	
V_{IH}	Driver high-level input voltage	DIN	$V_{CC} = 3.3\text{ V}$		2	V
			$V_{CC} = 5\text{ V}$		2.4	
V_{IL}	Driver low-level input voltage	DIN			0.8	V
V_I	Driver input voltage	DIN		0	5.5	V
	Receiver input voltage			-25	25	
T_A	Operating free-air temperature	TRSF3232EI	-40		85	°C
		TRSF3232EC	0		70	

(1) Test conditions are C1–C4 = 0.1 μF at $V_{CC} = 3.3\text{ V} \pm 0.3\text{ V}$; C1 = 0.047 μF , C2–C4 = 0.33 μF at $V_{CC} = 5\text{ V} \pm 0.5\text{ V}$ (see [8-1](#)).

5.6 Thermal Information

THERMAL METRIC ⁽¹⁾		TRSF3232E						UNIT
		PW (TSSOP)	D (SOIC)	DW (SOIC)	DB (SSOP)	RGT (VQFN)	DYY (SOT-23-THN)	
		16 Pins	16 Pins	16 Pins	16 Pins	16 Pins	16 Pins	
$R_{\theta JA}$	Junction-to-ambient thermal resistance	108.2	85.9	57	46	48.8	106.2	°C/W
$R_{\theta JC(top)}$	Junction-to-case (bottom) thermal resistance	39.0	43.1	33.5	36.2	55.8	47.4	°C/W
$R_{\theta JB}$	Junction-to-board thermal resistance	54.4	44.5	37.1	43.8	23.2	44.7	°C/W
Ψ_{JT}	Junction-to-top characterization parameter	3.3	10.1	7.5	4.2	1.7	1.7	°C/W
Ψ_{JB}	Junction-to-board characterization parameter	53.8	44.1	37.1	42.9	23.2	43.7	°C/W
$R_{\theta JC(bot)}$	Junction-to-case (bottom) thermal resistance	N/A	N/A	N/A	N/A	9.0	N/A	°C/W

(1) For more information about traditional and new thermal metrics, see the [Semiconductor and IC package thermal metrics](#) application report.

5.7 Electrical Characteristics

over recommended ranges of supply voltage and operating free-air temperature (unless otherwise noted)

PARAMETER	TEST CONDITIONS ⁽¹⁾	MIN	TYP ⁽²⁾	MAX	UNIT	
I_{CC}	Supply current	No load, $V_{CC} = 3.3\text{ V}$ or 5 V		0.3	1	mA

(1) Test conditions are C1–C4 = 0.1 μF at $V_{CC} = 3.3\text{ V} \pm 0.3\text{ V}$; C1 = 0.047 μF , C2–C4 = 0.33 μF at $V_{CC} = 5\text{ V} \pm 0.5\text{ V}$ (see [8-1](#)).

(2) All typical values are at $V_{CC} = 3.3\text{ V}$ or $V_{CC} = 5\text{ V}$, and $T_A = 25^\circ\text{C}$.

5.8 Electrical Characteristics, Driver

over recommended ranges of supply voltage and operating free-air temperature (unless otherwise noted)

PARAMETER	TEST CONDITIONS ⁽¹⁾	MIN	TYP ⁽²⁾	MAX	UNIT
V _{OH} High-level output voltage	DOUT at R _L = 3 kΩ to GND, DIN = GND	5	5.5		V
V _{OL} Low-level output voltage	DOUT at R _L = 3 kΩ to GND, DIN = V _{CC}	–5	–5.4		V
I _{IH} High-level input current	V _I = V _{CC}		±0.01	±1	μA
I _{IL} Low-level input current	V _I at GND		±0.01	±1	μA
I _{OS} ⁽³⁾ Short-circuit output current	V _{CC} = 3.6 V, V _O = 0 V		±35	±60	mA
	V _{CC} = 5.5 V, V _O = 0 V	RGT package only	±35	±60	
		D, DB, DW, PW packages	±35	±90	
r _o Output resistance	V _{CC} , V+, and V– = 0 V, V _O = ±2 V	300	10M		Ω

(1) Test conditions are C1–C4 = 0.1 μF at V_{CC} = 3.3 V ± 0.3 V; C1 = 0.047 μF, C2–C4 = 0.33 μF at V_{CC} = 5 V ± 0.5 V (see [8-1](#)).

(2) All typical values are at V_{CC} = 3.3 V or V_{CC} = 5 V, and T_A = 25°C.

(3) Short-circuit durations should be controlled to prevent exceeding the device absolute power dissipation ratings, and not more than one output should be shorted at a time.

5.9 Electrical Characteristics, Receiver

over recommended ranges of supply voltage and operating free-air temperature (unless otherwise noted)

PARAMETER	TEST CONDITIONS ⁽¹⁾	MIN	TYP ⁽²⁾	MAX	UNIT
V _{OH} High-level output voltage	I _{OH} = –1 mA	V _{CC} – 0.6	V _{CC} – 0.1		V
V _{OL} Low-level output voltage	I _{OL} = 1.6 mA			0.4	V
V _{IT+} Positive-going input threshold voltage	V _{CC} = 3.3 V		1.5	2.4	V
	V _{CC} = 5 V		1.8	2.4	
V _{IT–} Negative-going input threshold voltage	V _{CC} = 3.3 V	0.6	1.2		V
	V _{CC} = 5 V	0.8	1.5		
V _{hys} Input hysteresis (V _{IT+} – V _{IT–})			0.3		V
r _i Input resistance	V _I = ±3 V to ±25 V	3	5	7	kΩ

(1) Test conditions are C1–C4 = 0.1 μF at V_{CC} = 3.3 V ± 0.3 V; C1 = 0.047 μF, C2–C4 = 0.33 μF at V_{CC} = 5 V ± 0.5 V (see [8-1](#)).

(2) All typical values are at V_{CC} = 3.3 V or V_{CC} = 5 V, and T_A = 25°C.

5.10 Switching Characteristics, Driver

over recommended ranges of supply voltage and operating free-air temperature (unless otherwise noted)

		TEST CONDITIONS ⁽¹⁾		MIN	TYP ⁽²⁾	MAX	UNIT
Maximum data rate (see 6-1)	R _L = 3 kΩ, One DOUT switching	C _L = 250 pF, V _{CC} = 3 V to 4.5 V		1000			kbit/s
		C _L = 1000 pF, V _{CC} = 3.5 V to 5.5 V		1000			
t _{sk(p)} Pulse skew ⁽³⁾	C _L = 1000 pF, R _L = 3 kΩ, V _{CC} = 5 V (see 6-2)	RGT package only		70			ns
	C _L = 150 pF to 2500 pF, R _L = 3 kΩ to 7 kΩ (see 6-2)	D, DB, DW, PW packages		300			
SR(tr) Slew rate, transition region (see 6-1)	R _L = 3 kΩ to 7 kΩ, C _L = 150 pF to 1000 pF, V _{CC} = 3.3 V			14		150	V/μs

- (1) Test conditions are C₁–C₄ = 0.1 μF at V_{CC} = 3.3 V ± 0.3 V; C₁ = 0.047 μF, C₂–C₄ = 0.33 μF at V_{CC} = 5 V ± 0.5 V (see [8-1](#)).
(2) All typical values are at V_{CC} = 3.3 V or V_{CC} = 5 V, and T_A = 25°C.
(3) Pulse skew is defined as |t_{PLH} – t_{PHL}| of each channel of the same device.

5.11 Switching Characteristics, Receiver

over recommended ranges of supply voltage and operating free-air temperature (unless otherwise noted)

		TEST CONDITIONS ⁽¹⁾		MIN	TYP ⁽²⁾	MAX	UNIT
t _{PLH} Propagation delay time, low- to high-level output	C _L = 150 pF	RGT package		85			ns
		D, DB, DW, PW packages		300			
t _{PHL} Propagation delay time, high- to low-level output	C _L = 150 pF	RGT package		110			ns
		D, DB, DW, PW packages		300			
t _{sk(p)} Pulse skew ⁽³⁾		RGT package		25			ns
		D, DB, DW, PW packages		300			

- (1) Test conditions are C₁–C₄ = 0.1 μF at V_{CC} = 3.3 V ± 0.3 V; C₁ = 0.047 μF, C₂–C₄ = 0.33 μF at V_{CC} = 5 V ± 0.5 V (see [8-1](#)).
(2) All typical values are at V_{CC} = 3.3 V or V_{CC} = 5 V, and T_A = 25°C.
(3) Pulse skew is defined as |t_{PLH} – t_{PHL}| of each channel of the same device.

5.12 Typical Characteristics

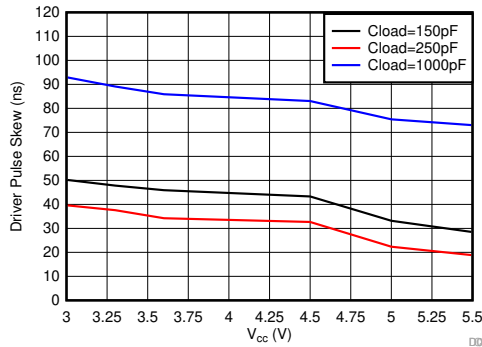

D003_SLLS825.grf

5-1. Driver pulse skew at T_A = 25°C (RGT package)

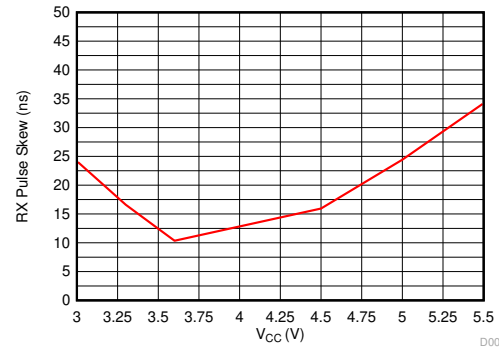

D004_SLLS825.grf

5-2. Receiver path skew at T_A = 25°C (t_{pHL}-t_{pLH}) (RGT package)

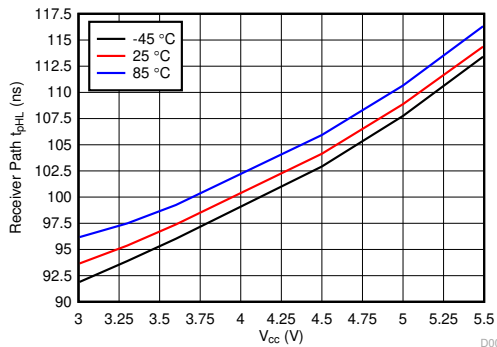

D005_SLLS825.grf

5-3. Receiver path high-to-low propagation delay, C_L = 150pF (RGT package)

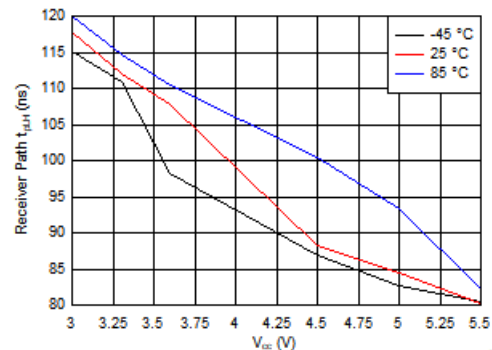

D006_SLLS825.grf

5-4. Receiver path low-to-high propagation delay, C_L = 150pF (RGT package)

6 Parameter Measurement Information

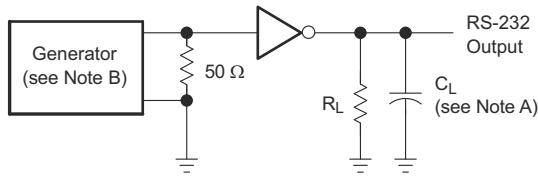

TEST CIRCUIT

$$SR(tr) = \frac{6\text{ V}}{t_{THL} \text{ or } t_{TLH}}$$

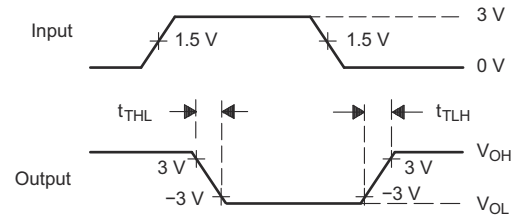

VOLTAGE WAVEFORMS

NOTES: A. C_L includes probe and jig capacitance.

B. The pulse generator has the following characteristics: PRR = 250 kbit/s, $Z_O = 50\ \Omega$, 50% duty cycle, $t_r \leq 10\text{ ns}$, $t_f \leq 10\text{ ns}$.

6-1. Driver Slew Rate

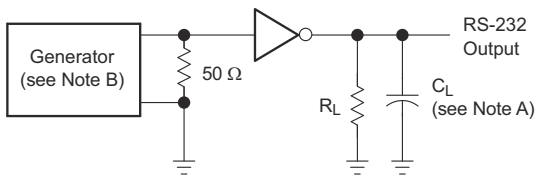

TEST CIRCUIT

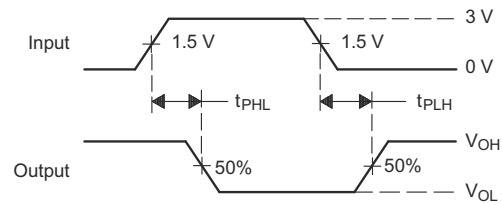

VOLTAGE WAVEFORMS

NOTES: A. C_L includes probe and jig capacitance.

B. The pulse generator has the following characteristics: PRR = 250 kbit/s, $Z_O = 50\ \Omega$, 50% duty cycle, $t_r \leq 10\text{ ns}$, $t_f \leq 10\text{ ns}$.

6-2. Driver Pulse Skew

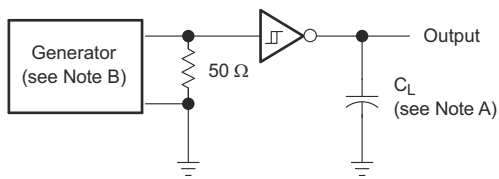

TEST CIRCUIT

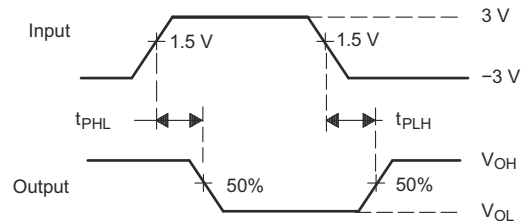

VOLTAGE WAVEFORMS

NOTES: A. C_L includes probe and jig capacitance.

B. The pulse generator has the following characteristics: $Z_O = 50\ \Omega$, 50% duty cycle, $t_r \leq 10\text{ ns}$, $t_f \leq 10\text{ ns}$.

6-3. Receiver Propagation Delay Times

7 Detailed Description

7.1 Overview

The TRSF3232E device consists of two line drivers, two line receivers, and a dual charge-pump circuit with $\pm 15\text{kV}$ IEC ESD protection between serial-port connection terminals and GND. The device meets the requirements of TIA/EIA-232-F and provides the electrical interface between an asynchronous communication controller and the serial-port connector. The charge pump and four small external capacitors allow operation from one 3V to 5.5V supply. The device operates at data signaling rates up to 1Mbps and a maximum of $150\text{V}/\mu\text{s}$ driver output slew rate. Outputs are protected against shorts to ground.

7.2 Functional Block Diagram

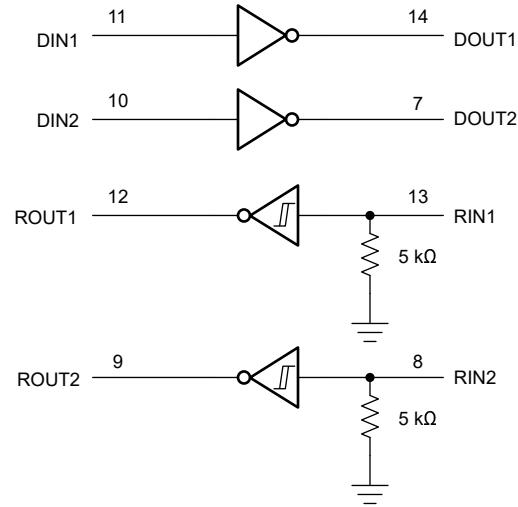

7.3 Feature Description

7.3.1 Power

The power block increases, inverts, and regulates voltage at V+ and V– pins using a charge pump that requires four external capacitors.

7.3.2 RS232 Driver

Two drivers interface the standard logic level to RS232 levels. Both DIN inputs must be valid high or low.

7.3.3 RS232 Receiver

Two receivers interface RS232 levels to standard logic levels. An open input results in a high output on ROUT. Each RIN input includes an internal standard RS232 load.

7.4 Device Functional Modes

表 7-1. Each Driver

INPUT DIN ⁽¹⁾	OUTPUT DOUT
L	H
H	L

(1) H = high level, L = low level

表 7-2. Each Receiver

INPUT RIN ⁽¹⁾	OUTPUT ROUT
L	H
H	L
Open	H

(1) H = high level, L = low level,
Open = input disconnected or connected driver off

7.4.1 V_{CC} Powered by 3V to 5.5V

The device is in normal operation.

7.4.2 V_{CC} Unpowered, $V_{CC} = 0V$

When the TRSF3232 device is unpowered, it can be safely connected to an active remote RS232 device.

8 Application and Implementation

注

以下のアプリケーション情報は、TI の製品仕様に含まれるものではなく、TI ではその正確性または完全性を保証いたしません。個々の目的に対する製品の適合性については、お客様の責任で判断していただくこととなります。お客様は自身の設計実装を検証しテストすることで、システムの機能を確認する必要があります。

8.1 Application Information

The TRSF3232E device is designed to convert single-ended signals into RS232-compatible signals, and vice-versa. This device can be used in any application where an RS232 line driver or receiver is required.

ROUT and DIN connect to UART or general-purpose logic lines. RIN and DOUT lines connect to a RS232 connector or cable.

8.2 Typical Application

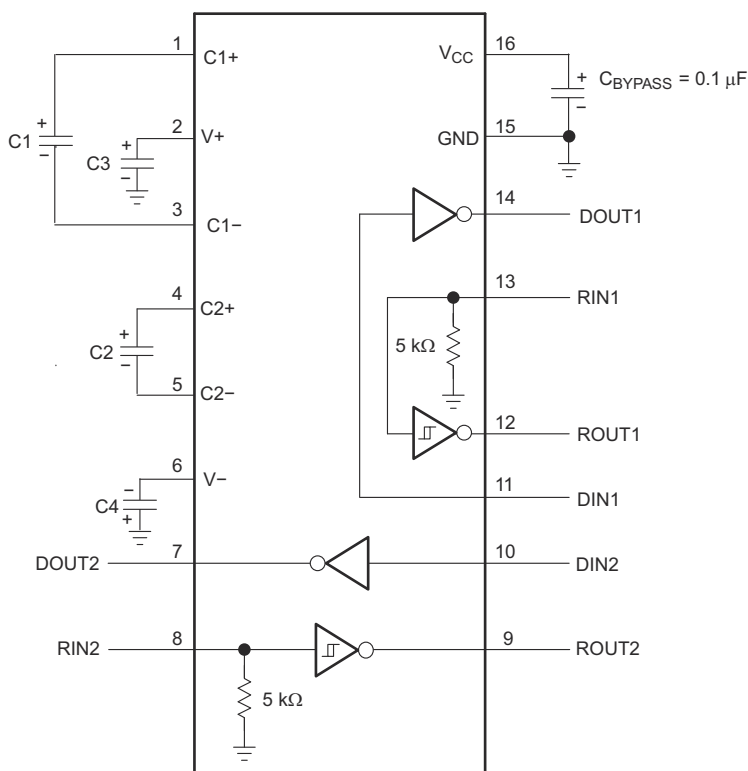

A. C3 can be connected to V_{CC} or GND.

図 8-1. Typical Operating Circuit and Capacitor Values

表 8-1. VCC vs Capacitor Values

V_{CC}	C1	C2, C3, C4
$3.3V \pm 0.3V$	$0.1\mu F$	$0.1\mu F$
$5V \pm 0.5V$	$0.047\mu F$	$0.33\mu F$
3V to 5.5V	$0.1\mu F$	$0.47\mu F$

8.2.1 Design Requirements

- Recommended V_{CC} is 3.3V or 5V
 - 3V to 5.5V is also possible
- Maximum recommended bit rate is 250kbites

8.2.2 Detailed Design Procedure

All DIN inputs must be connected to valid low or high logic levels. Select capacitor values based on VCC level for best performance.

8.2.3 Application Performance Plots

VCC must be between 3 V and 5.5 V. Charge pump capacitors must be chosen using 表 8-1

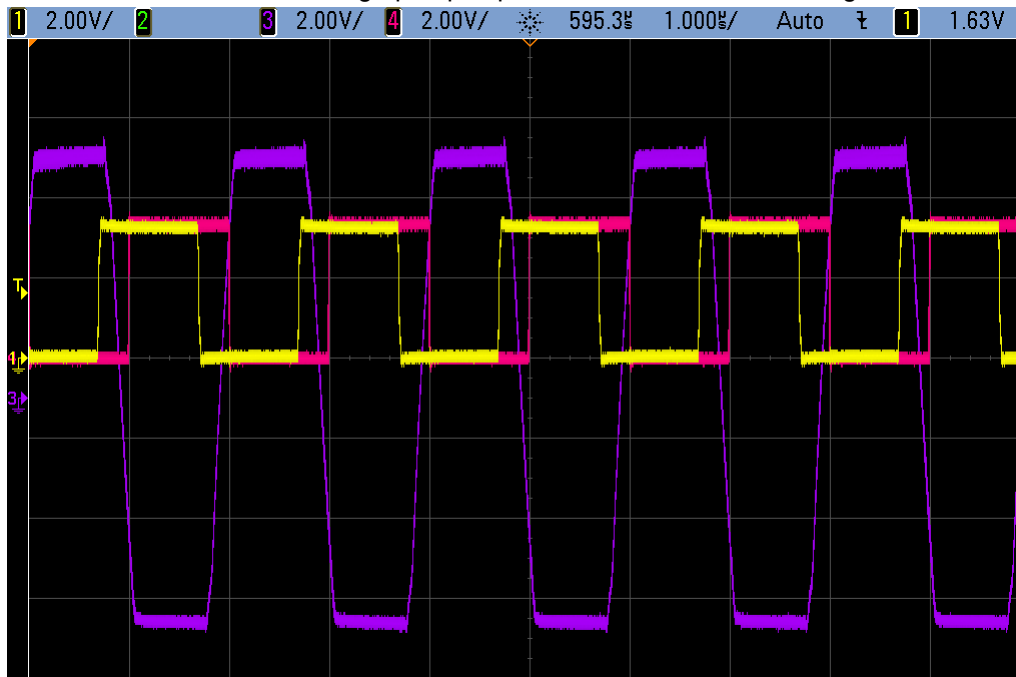

 8-2. 1Mbps timing waveform from driver input to receiver output loopback. DOUT to RIN trace is in purple, DIN trace is in yellow and ROUT trace is in pink

8.3 Power Supply Recommendations

The supply voltage, V_{CC} , should be between 3V and 5.5V. Select the charge-pump capacitors using 表 8-1.

8.4 Layout

8.4.1 Layout Guidelines

Keep the external capacitor traces short, specifically on the C1 and C2 nodes that have the fastest rise and fall times.

8.4.2 Layout Example



図 8-3. Layout Diagram

9 Device and Documentation Support

TI offers an extensive line of development tools. Tools and software to evaluate the performance of the device, generate code, and develop solutions are listed below.

9.1 ドキュメントの更新通知を受け取る方法

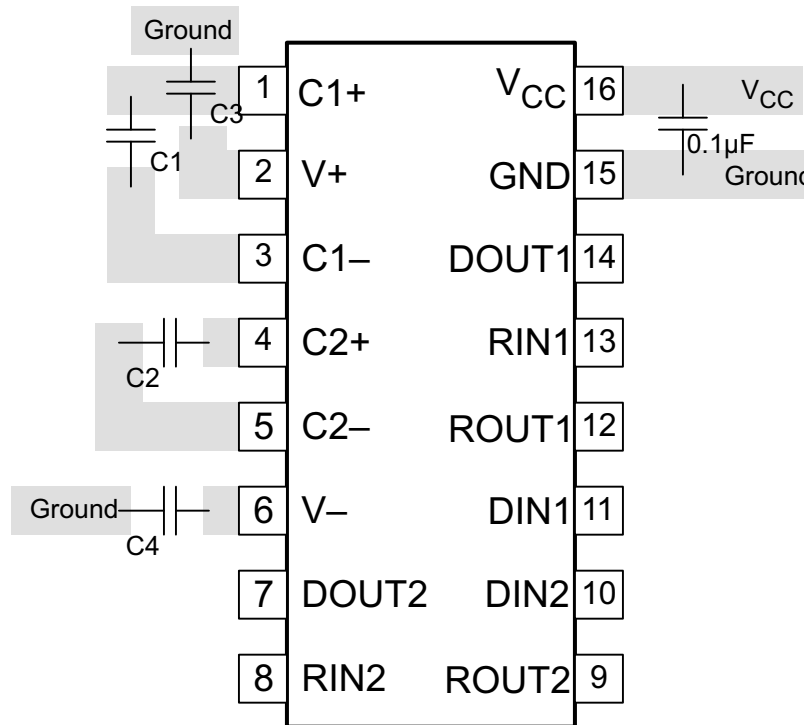
ドキュメントの更新についての通知を受け取るには、www.tij.co.jp のデバイス製品フォルダを開いてください。[通知] をクリックして登録すると、変更されたすべての製品情報に関するダイジェストを毎週受け取ることができます。変更の詳細については、改訂されたドキュメントに含まれている改訂履歴をご覧ください。

9.2 サポート・リソース

テキサス・インスツルメンツ E2E™ サポート・フォーラムは、エンジニアが検証済みの回答と設計に関するヒントをエキスパートから迅速かつ直接得ることができる場所です。既存の回答を検索したり、独自の質問をしたりすることで、設計に必要な支援を迅速に得ることができます。

リンクされているコンテンツは、各寄稿者により「現状のまま」提供されるものです。これらはテキサス・インスツルメンツの仕様を構成するものではなく、必ずしもテキサス・インスツルメンツの見解を反映したものではありません。テキサス・インスツルメンツの[使用条件](#)を参照してください。

9.3 商標

テキサス・インスツルメンツ E2E™ is a trademark of Texas Instruments.

すべての商標は、それぞれの所有者に帰属します。

9.4 静電気放電に関する注意事項



この IC は、ESD によって破損する可能性があります。テキサス・インスツルメンツは、IC を取り扱う際には常に適切な注意を払うことを推奨します。正しい取り扱いおよび設置手順に従わない場合、デバイスを破損するおそれがあります。

ESD による破損は、わずかな性能低下からデバイスの完全な故障まで多岐にわたります。精密な IC の場合、パラメータがわずかに変化するだけで公表されている仕様から外れる可能性があるため、破損が発生しやすくなっています。

9.5 用語集

[テキサス・インスツルメンツ用語集](#) この用語集には、用語や略語の一覧および定義が記載されています。

10 Revision History

資料番号末尾の英字は改訂を表しています。その改訂履歴は英語版に準じています。

Changes from Revision B (June 2021) to Revision C (December 2024)	Page
• 「製品情報」表を「パッケージ情報」表に変更.....	1
• データシートに SOT-23-THN (DYY) パッケージを追加.....	1
• Added Note 2 to the <i>ESD Protection, Driver</i>	4
• Added Note 2 to the <i>ESD Protection, Receiver</i>	4

Changes from Revision A (December 2020) to Revision B (June 2021)	Page
• 以下の「アプリケーション」を追加。産業用 PC、有線ネットワーク、データ・センターおよびエンタープライズ・コンピューティング.....	1
• Changed the table note in the <i>ESD Protection, Driver</i> table to make it applicable to D and PW packages.....	4
• Changed the table note in the <i>ESD Protection, Receiver</i> table to make it applicable to D and PW packages..	4
• Changed the thermal parameter values for D and PW packages in the <i>Thermal Information</i> table.....	5

Changes from Revision * (August 2007) to Revision A (December 2020)	Page
• 「製品情報」表、「ESD 定格」表、「機能説明」セクション、「デバイスの機能モード」セクション、「アプリケーションと実装」セクション、「電源に関する推奨事項」セクション、「レイアウト」セクション、「デバイスおよびドキュメントのサポート」セクション、「メカニカル、パッケージ、および注文情報」セクションを追加.....	1
• Added Note to the <i>ESD Protection, Driver</i>	4
• Added Note to the <i>ESD Protection, Receiver</i>	4
• Added $t_{sk(p)}$ row for RGT package in the <i>Switching Characteristics, Driver</i>	7
• Added t_{PLH} and t_{PHL} rows for RGT package in the <i>Switching Characteristics, Receiver</i>	7
• Added $t_{sk(p)}$ row for RGT package in the <i>Switching Characteristics, Receiver</i>	7

11 メカニカル、パッケージ、および注文情報

以降のページには、メカニカル、パッケージ、および注文に関する情報が記載されています。この情報は、指定のデバイスに使用できる最新のデータです。このデータは、予告なく、このドキュメントを改訂せずに変更される場合があります。本データシートのブラウザ版を使用されている場合は、画面左側の説明をご覧ください。

PACKAGING INFORMATION

Orderable part number	Status (1)	Material type (2)	Package Pins	Package qty Carrier	RoHS (3)	Lead finish/ Ball material (4)	MSL rating/ Peak reflow (5)	Op temp (°C)	Part marking (6)
TRSF3232ECDBR	Active	Production	SSOP (DB) 16	2000 LARGE T&R	Yes	NIPDAU	Level-1-260C-UNLIM	0 to 70	RT32EC
TRSF3232ECDBR.A	Active	Production	SSOP (DB) 16	2000 LARGE T&R	Yes	NIPDAU	Level-1-260C-UNLIM	-40 to 85	RT32EC
TRSF3232ECDR	Active	Production	SOIC (D) 16	2500 LARGE T&R	Yes	NIPDAU	Level-1-260C-UNLIM	0 to 70	TRSF3232EC
TRSF3232ECDR.A	Active	Production	SOIC (D) 16	2500 LARGE T&R	Yes	NIPDAU	Level-1-260C-UNLIM	-40 to 85	TRSF3232EC
TRSF3232ECDWR	Obsolete	Production	SOIC (DW) 16	-	-	Call TI	Call TI	0 to 70	TRSF3232EC
TRSF3232ECPWR	Active	Production	TSSOP (PW) 16	2000 LARGE T&R	Yes	NIPDAU SN	Level-1-260C-UNLIM	0 to 70	RT32EC
TRSF3232ECPWR.A	Active	Production	TSSOP (PW) 16	2000 LARGE T&R	Yes	NIPDAU	Level-1-260C-UNLIM	-40 to 85	RT32EC
TRSF3232EID	Obsolete	Production	SOIC (D) 16	-	-	Call TI	Call TI	-40 to 85	TRSF3232EI
TRSF3232EIDBR	Active	Production	SSOP (DB) 16	2000 LARGE T&R	Yes	NIPDAU	Level-1-260C-UNLIM	-40 to 85	RT32EI
TRSF3232EIDBR.A	Active	Production	SSOP (DB) 16	2000 LARGE T&R	Yes	NIPDAU	Level-1-260C-UNLIM	-40 to 85	RT32EI
TRSF3232EIDR	Active	Production	SOIC (D) 16	2500 LARGE T&R	Yes	NIPDAU	Level-1-260C-UNLIM	-40 to 85	TRSF3232EI
TRSF3232EIDR.A	Active	Production	SOIC (D) 16	2500 LARGE T&R	Yes	NIPDAU	Level-1-260C-UNLIM	-40 to 85	TRSF3232EI
TRSF3232EIDRG4.A	Active	Production	SOIC (D) 16	2500 LARGE T&R	Yes	NIPDAU	Level-1-260C-UNLIM	-40 to 85	TRSF3232EI
TRSF3232EIDW	Active	Production	SOIC (DW) 16	40 TUBE	Yes	NIPDAU	Level-1-260C-UNLIM	-40 to 85	TRSF3232EI
TRSF3232EIDW.A	Active	Production	SOIC (DW) 16	40 TUBE	Yes	NIPDAU	Level-1-260C-UNLIM	-40 to 85	TRSF3232EI
TRSF3232EIDWR	Active	Production	SOIC (DW) 16	2000 LARGE T&R	Yes	NIPDAU	Level-1-260C-UNLIM	-40 to 85	TRSF3232EI
TRSF3232EIDWR.A	Active	Production	SOIC (DW) 16	2000 LARGE T&R	Yes	NIPDAU	Level-1-260C-UNLIM	-40 to 85	TRSF3232EI
TRSF3232EIDYYR	Active	Production	SOT-23-THIN (DYY) 16	3000 LARGE T&R	Yes	NIPDAU	Level-1-260C-UNLIM	-40 to 85	RT32EI
TRSF3232EIDYYR.A	Active	Production	SOT-23-THIN (DYY) 16	3000 LARGE T&R	Yes	NIPDAU	Level-1-260C-UNLIM	-40 to 85	RT32EI
TRSF3232EIPWR	Active	Production	TSSOP (PW) 16	2000 LARGE T&R	Yes	NIPDAU	Level-1-260C-UNLIM	-40 to 85	RT32EI
TRSF3232EIPWR.A	Active	Production	TSSOP (PW) 16	2000 LARGE T&R	Yes	NIPDAU	Level-1-260C-UNLIM	-40 to 85	RT32EI
TRSF3232EIPWRG4.A	Active	Production	TSSOP (PW) 16	2000 LARGE T&R	Yes	NIPDAU	Level-1-260C-UNLIM	-40 to 85	RT32EI
TRSF3232EIRGTR	Active	Production	VQFN (RGT) 16	3000 LARGE T&R	Yes	NIPDAU	Level-1-260C-UNLIM	-40 to 85	F3232
TRSF3232EIRGTR.A	Active	Production	VQFN (RGT) 16	3000 LARGE T&R	Yes	NIPDAU	Level-1-260C-UNLIM	-40 to 85	F3232

(1) **Status:** For more details on status, see our [product life cycle](#).

- (2) **Material type:** When designated, preproduction parts are prototypes/experimental devices, and are not yet approved or released for full production. Testing and final process, including without limitation quality assurance, reliability performance testing, and/or process qualification, may not yet be complete, and this item is subject to further changes or possible discontinuation. If available for ordering, purchases will be subject to an additional waiver at checkout, and are intended for early internal evaluation purposes only. These items are sold without warranties of any kind.
- (3) **RoHS values:** Yes, No, RoHS Exempt. See the [TI RoHS Statement](#) for additional information and value definition.
- (4) **Lead finish/Ball material:** Parts may have multiple material finish options. Finish options are separated by a vertical ruled line. Lead finish/Ball material values may wrap to two lines if the finish value exceeds the maximum column width.
- (5) **MSL rating/Peak reflow:** The moisture sensitivity level ratings and peak solder (reflow) temperatures. In the event that a part has multiple moisture sensitivity ratings, only the lowest level per JEDEC standards is shown. Refer to the shipping label for the actual reflow temperature that will be used to mount the part to the printed circuit board.
- (6) **Part marking:** There may be an additional marking, which relates to the logo, the lot trace code information, or the environmental category of the part.

Multiple part markings will be inside parentheses. Only one part marking contained in parentheses and separated by a "~" will appear on a part. If a line is indented then it is a continuation of the previous line and the two combined represent the entire part marking for that device.

Important Information and Disclaimer: The information provided on this page represents TI's knowledge and belief as of the date that it is provided. TI bases its knowledge and belief on information provided by third parties, and makes no representation or warranty as to the accuracy of such information. Efforts are underway to better integrate information from third parties. TI has taken and continues to take reasonable steps to provide representative and accurate information but may not have conducted destructive testing or chemical analysis on incoming materials and chemicals. TI and TI suppliers consider certain information to be proprietary, and thus CAS numbers and other limited information may not be available for release.

In no event shall TI's liability arising out of such information exceed the total purchase price of the TI part(s) at issue in this document sold by TI to Customer on an annual basis.

TAPE AND REEL INFORMATION

QUADRANT ASSIGNMENTS FOR PIN 1 ORIENTATION IN TAPE



*All dimensions are nominal

Device	Package Type	Package Drawing	Pins	SPQ	Reel Diameter (mm)	Reel Width W1 (mm)	A0 (mm)	B0 (mm)	K0 (mm)	P1 (mm)	W (mm)	Pin1 Quadrant
TRSF3232ECDBR	SSOP	DB	16	2000	330.0	16.4	8.35	6.6	2.4	12.0	16.0	Q1
TRSF3232ECDR	SOIC	D	16	2500	330.0	16.4	6.5	10.3	2.1	8.0	16.0	Q1
TRSF3232ECDR	SOIC	D	16	2500	330.0	16.4	6.5	10.3	2.1	8.0	16.0	Q1
TRSF3232ECPWR	TSSOP	PW	16	2000	330.0	12.4	6.9	5.6	1.6	8.0	12.0	Q1
TRSF3232ECPWR	TSSOP	PW	16	2000	330.0	12.4	6.9	5.6	1.6	8.0	12.0	Q1
TRSF3232EIDBR	SSOP	DB	16	2000	330.0	16.4	8.35	6.6	2.4	12.0	16.0	Q1
TRSF3232EIDR	SOIC	D	16	2500	330.0	16.4	6.5	10.3	2.1	8.0	16.0	Q1
TRSF3232EIDR	SOIC	D	16	2500	330.0	16.4	6.5	10.3	2.1	8.0	16.0	Q1
TRSF3232EIDWR	SOIC	DW	16	2000	330.0	16.4	10.75	10.7	2.7	12.0	16.0	Q1
TRSF3232EIDYYR	SOT-23-THIN	DYY	16	3000	330.0	12.4	4.8	3.6	1.6	8.0	12.0	Q3
TRSF3232EIPWR	TSSOP	PW	16	2000	330.0	12.4	6.9	5.6	1.6	8.0	12.0	Q1
TRSF3232EIPWR	TSSOP	PW	16	2000	330.0	12.4	6.9	5.6	1.6	8.0	12.0	Q1
TRSF3232EIRGTR	VQFN	RGT	16	3000	330.0	12.4	3.3	3.3	1.1	8.0	12.0	Q2

TAPE AND REEL BOX DIMENSIONS

*All dimensions are nominal

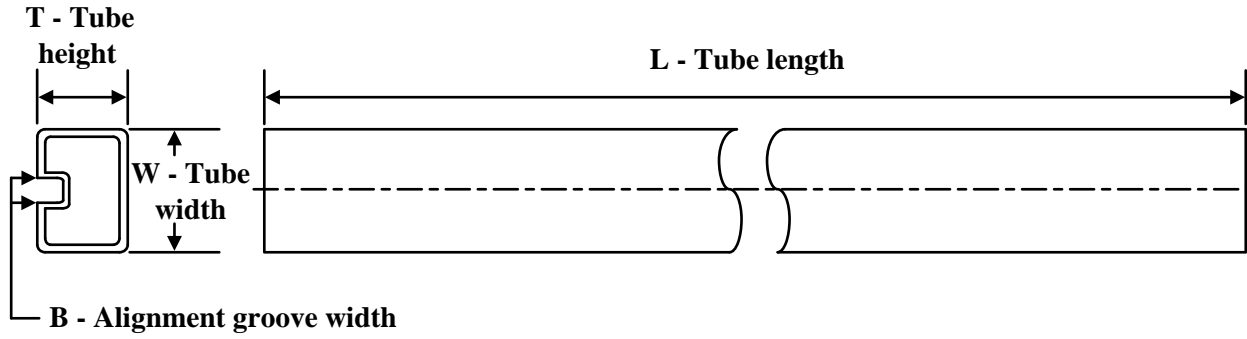
Device	Package Type	Package Drawing	Pins	SPQ	Length (mm)	Width (mm)	Height (mm)
TRSF3232ECDBR	SSOP	DB	16	2000	356.0	356.0	35.0
TRSF3232ECDR	SOIC	D	16	2500	356.0	356.0	35.0
TRSF3232ECDR	SOIC	D	16	2500	356.0	356.0	35.0
TRSF3232ECPWR	TSSOP	PW	16	2000	356.0	356.0	35.0
TRSF3232ECPWR	TSSOP	PW	16	2000	356.0	356.0	35.0
TRSF3232EIDBR	SSOP	DB	16	2000	356.0	356.0	35.0
TRSF3232EIDR	SOIC	D	16	2500	356.0	356.0	35.0
TRSF3232EIDR	SOIC	D	16	2500	356.0	356.0	35.0
TRSF3232EIDWR	SOIC	DW	16	2000	350.0	350.0	43.0
TRSF3232EIDYYR	SOT-23-THIN	DYY	16	3000	336.6	336.6	31.8
TRSF3232EIPWR	TSSOP	PW	16	2000	356.0	356.0	35.0
TRSF3232EIPWR	TSSOP	PW	16	2000	356.0	356.0	35.0
TRSF3232EIRGTR	VQFN	RGT	16	3000	367.0	367.0	35.0

TUBE

*All dimensions are nominal

Device	Package Name	Package Type	Pins	SPQ	L (mm)	W (mm)	T (μm)	B (mm)
TRSF3232EIDW	DW	SOIC	16	40	506.98	12.7	4826	6.6
TRSF3232EIDW.A	DW	SOIC	16	40	506.98	12.7	4826	6.6

D (R-PDSO-G16)

PLASTIC SMALL OUTLINE



- NOTES:
- A. All linear dimensions are in inches (millimeters).
 - B. This drawing is subject to change without notice.
 - C. Body length does not include mold flash, protrusions, or gate burrs. Mold flash, protrusions, or gate burrs shall not exceed 0.006 (0,15) each side.
 - D. Body width does not include interlead flash. Interlead flash shall not exceed 0.017 (0,43) each side.
 - E. Reference JEDEC MS-012 variation AC.



4220204/A 02/2017

NOTES:

1. All linear dimensions are in millimeters. Any dimensions in parenthesis are for reference only. Dimensioning and tolerancing per ASME Y14.5M.
2. This drawing is subject to change without notice.
3. This dimension does not include mold flash, protrusions, or gate burrs. Mold flash, protrusions, or gate burrs shall not exceed 0.15 mm per side.
4. This dimension does not include interlead flash. Interlead flash shall not exceed 0.25 mm per side.
5. Reference JEDEC registration MO-153.

EXAMPLE BOARD LAYOUT

PW0016A

TSSOP - 1.2 mm max height

SMALL OUTLINE PACKAGE



LAND PATTERN EXAMPLE
EXPOSED METAL SHOWN
SCALE: 10X



4220204/A 02/2017

NOTES: (continued)

- 6. Publication IPC-7351 may have alternate designs.
- 7. Solder mask tolerances between and around signal pads can vary based on board fabrication site.

EXAMPLE STENCIL DESIGN

PW0016A

TSSOP - 1.2 mm max height

SMALL OUTLINE PACKAGE



SOLDER PASTE EXAMPLE
BASED ON 0.125 mm THICK STENCIL
SCALE: 10X

4220204/A 02/2017

NOTES: (continued)

8. Laser cutting apertures with trapezoidal walls and rounded corners may offer better paste release. IPC-7525 may have alternate design recommendations.
9. Board assembly site may have different recommendations for stencil design.

DB0016A



PACKAGE OUTLINE

SSOP - 2 mm max height

SMALL OUTLINE PACKAGE



4220763/A 05/2022

NOTES:

- All linear dimensions are in millimeters. Any dimensions in parenthesis are for reference only. Dimensioning and tolerancing per ASME Y14.5M.
- This drawing is subject to change without notice.
- This dimension does not include mold flash, protrusions, or gate burrs. Mold flash, protrusions, or gate burrs shall not exceed 0.15 mm per side.
- Reference JEDEC registration MO-150.

EXAMPLE BOARD LAYOUT

DB0016A

SSOP - 2 mm max height

SMALL OUTLINE PACKAGE



LAND PATTERN EXAMPLE
EXPOSED METAL SHOWN
SCALE: 10X



4220763/A 05/2022

NOTES: (continued)

- 5. Publication IPC-7351 may have alternate designs.
- 6. Solder mask tolerances between and around signal pads can vary based on board fabrication site.

EXAMPLE STENCIL DESIGN

DB0016A

SSOP - 2 mm max height

SMALL OUTLINE PACKAGE



SOLDER PASTE EXAMPLE
BASED ON 0.125 mm THICK STENCIL
SCALE: 10X

4220763/A 05/2022

NOTES: (continued)

7. Laser cutting apertures with trapezoidal walls and rounded corners may offer better paste release. IPC-7525 may have alternate design recommendations.
8. Board assembly site may have different recommendations for stencil design.

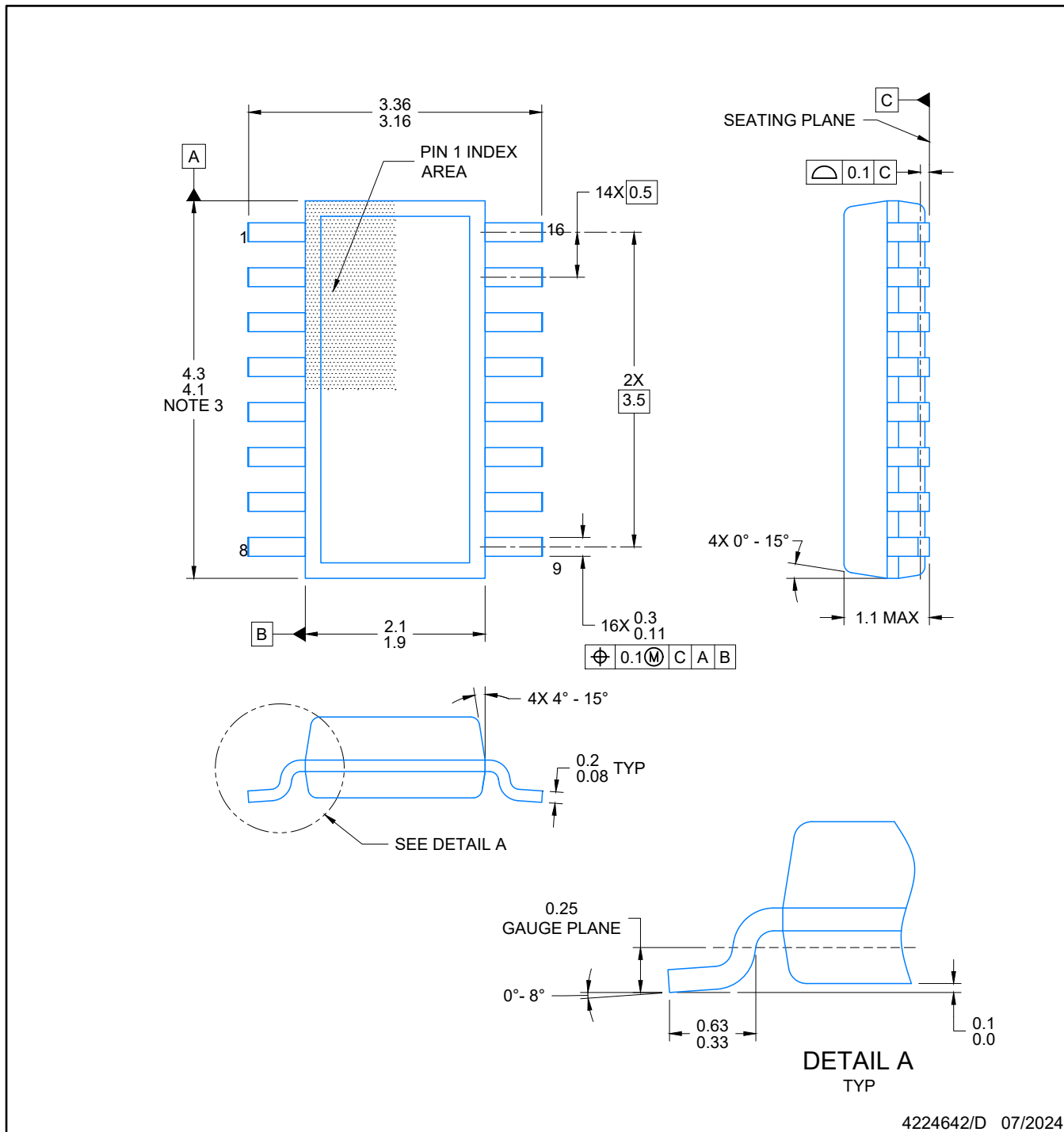

4224642/D 07/2024

NOTES:

1. All linear dimensions are in millimeters. Any dimensions in parenthesis are for reference only. Dimensioning and tolerancing per ASME Y14.5M.
2. This drawing is subject to change without notice.
3. This dimension does not include mold flash, protrusions, or gate burrs. Mold flash, protrusions, or gate burrs shall not exceed 0.15 per side.
4. This dimension does not include interlead flash. Interlead flash shall not exceed 0.50 per side.
5. Reference JEDEC Registration MO-345, Variation AA



LAND PATTERN EXAMPLE
EXPOSED METAL SHOWN
SCALE: 20X



4224642/D 07/2024

NOTES: (continued)

- 6. Publication IPC-7351 may have alternate designs.
- 7. Solder mask tolerances between and around signal pads can vary based on board fabrication site.

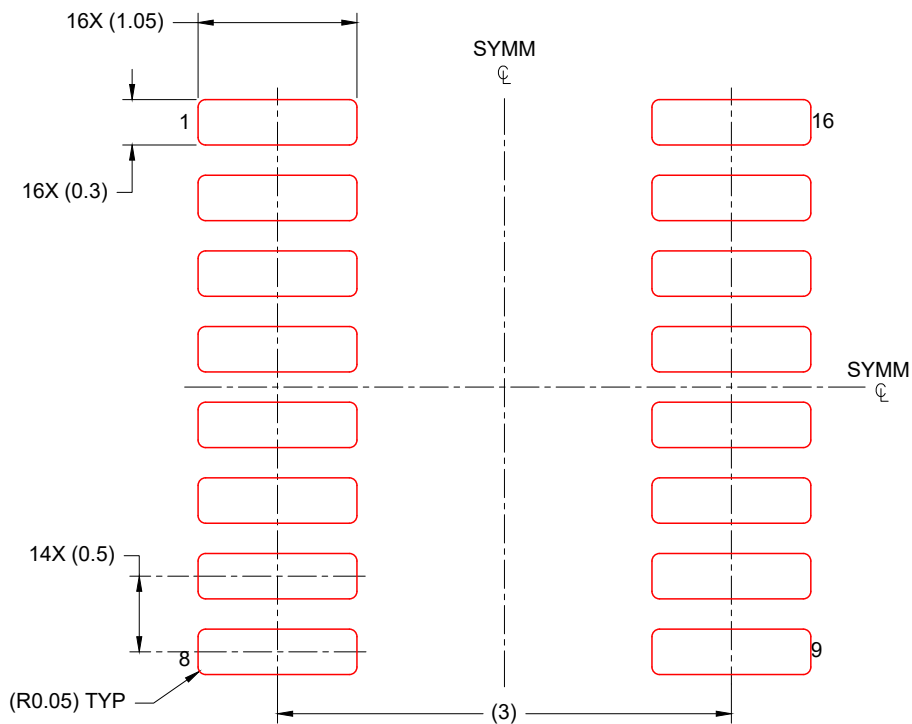

SOLDER PASTE EXAMPLE
BASED ON 0.125 mm THICK STENCIL
SCALE: 20X

4224642/D 07/2024

NOTES: (continued)

- 8. Laser cutting apertures with trapezoidal walls and rounded corners may offer better paste release. IPC-7525 may have alternate design recommendations.
- 9. Board assembly site may have different recommendations for stencil design.

GENERIC PACKAGE VIEW

DW 16

SOIC - 2.65 mm max height

7.5 x 10.3, 1.27 mm pitch

SMALL OUTLINE INTEGRATED CIRCUIT

This image is a representation of the package family, actual package may vary.
Refer to the product data sheet for package details.



4224780/A



DW0016A

PACKAGE OUTLINE

SOIC - 2.65 mm max height

SOIC



4220721/A 07/2016

NOTES:

1. All linear dimensions are in millimeters. Dimensions in parenthesis are for reference only. Dimensioning and tolerancing per ASME Y14.5M.
2. This drawing is subject to change without notice.
3. This dimension does not include mold flash, protrusions, or gate burrs. Mold flash, protrusions, or gate burrs shall not exceed 0.15 mm, per side.
4. This dimension does not include interlead flash. Interlead flash shall not exceed 0.25 mm, per side.
5. Reference JEDEC registration MS-013.

EXAMPLE BOARD LAYOUT

DW0016A

SOIC - 2.65 mm max height

SOIC



LAND PATTERN EXAMPLE
SCALE:7X



SOLDER MASK DETAILS

4220721/A 07/2016

NOTES: (continued)

6. Publication IPC-7351 may have alternate designs.

7. Solder mask tolerances between and around signal pads can vary based on board fabrication site.

EXAMPLE STENCIL DESIGN

DW0016A

SOIC - 2.65 mm max height

SOIC



SOLDER PASTE EXAMPLE
BASED ON 0.125 mm THICK STENCIL
SCALE:7X

4220721/A 07/2016

NOTES: (continued)

8. Laser cutting apertures with trapezoidal walls and rounded corners may offer better paste release. IPC-7525 may have alternate design recommendations.
9. Board assembly site may have different recommendations for stencil design.

RGT 16

GENERIC PACKAGE VIEW

VQFN - 1 mm max height

PLASTIC QUAD FLATPACK - NO LEAD



Images above are just a representation of the package family, actual package may vary.
Refer to the product data sheet for package details.

4203495/1

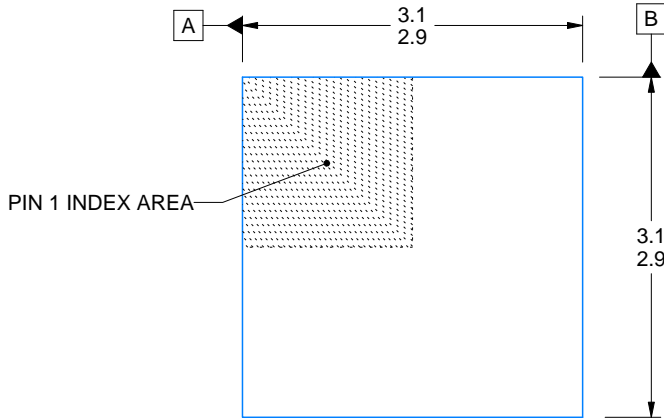

SIDE WALL METAL THICKNESS DIM A	
OPTION 1	OPTION 2
0.1	0.2



4222419/D 04/2022

NOTES:

1. All linear dimensions are in millimeters. Any dimensions in parenthesis are for reference only. Dimensioning and tolerancing per ASME Y14.5M.
2. This drawing is subject to change without notice.
3. The package thermal pad must be soldered to the printed circuit board for thermal and mechanical performance.

EXAMPLE BOARD LAYOUT

RGT0016C

VQFN - 1 mm max height

PLASTIC QUAD FLATPACK - NO LEAD

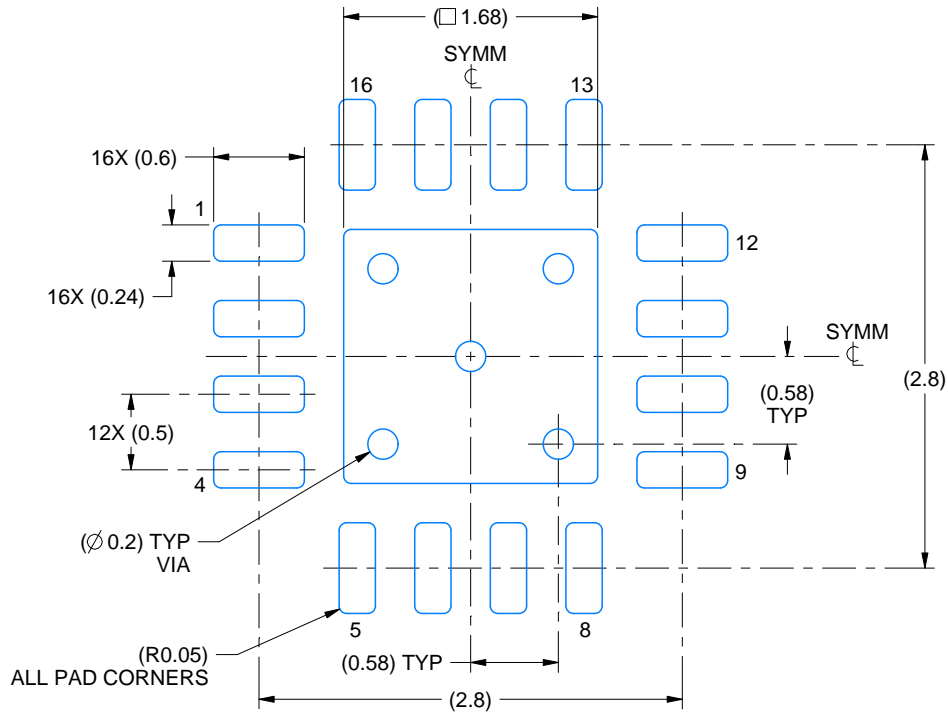

LAND PATTERN EXAMPLE
EXPOSED METAL SHOWN
SCALE:20X

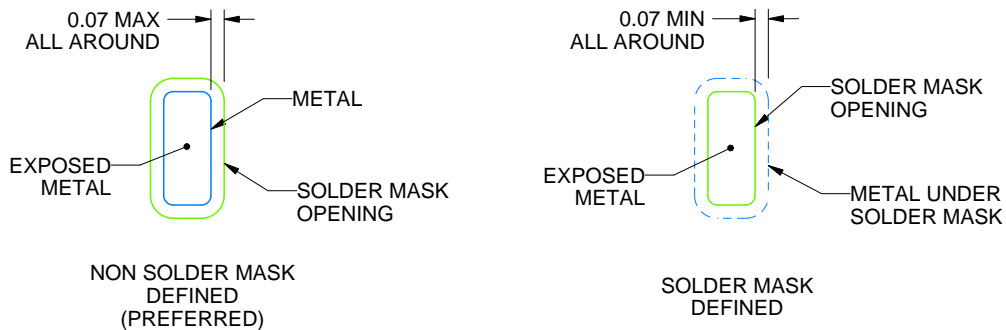

SOLDER MASK DETAILS

4222419/D 04/2022

NOTES: (continued)

4. This package is designed to be soldered to a thermal pad on the board. For more information, see Texas Instruments literature number SLUA271 (www.ti.com/lit/sluea271).
5. Vias are optional depending on application, refer to device data sheet. If any vias are implemented, refer to their locations shown on this view. It is recommended that vias under paste be filled, plugged or tented.

EXAMPLE STENCIL DESIGN

RGT0016C

VQFN - 1 mm max height

PLASTIC QUAD FLATPACK - NO LEAD



SOLDER PASTE EXAMPLE
BASED ON 0.125 mm THICK STENCIL

EXPOSED PAD 17:
85% PRINTED SOLDER COVERAGE BY AREA UNDER PACKAGE
SCALE:25X

4222419/D 04/2022

NOTES: (continued)

6. Laser cutting apertures with trapezoidal walls and rounded corners may offer better paste release. IPC-7525 may have alternate design recommendations.

重要なお知らせと免責事項

テキサス・インスツルメンツは、技術データと信頼性データ(データシートを含みます)、設計リソース(リファレンス デザインを含みます)、アプリケーションや設計に関する各種アドバイス、Web ツール、安全性情報、その他のリソースを、欠陥が存在する可能性のある「現状のまま」提供しており、商品性および特定目的に対する適合性の黙示保証、第三者の知的財産権の非侵害保証を含むいかなる保証も、明示的または黙示的にかかわらず拒否します。

これらのリソースは、テキサス・インスツルメンツ製品を使用する設計の経験を積んだ開発者への提供を意図したものです。(1) お客様のアプリケーションに適したテキサス・インスツルメンツ製品の選定、(2) お客様のアプリケーションの設計、検証、試験、(3) お客様のアプリケーションに該当する各種規格や、その他のあらゆる安全性、セキュリティ、規制、または他の要件への確実な適合に関する責任を、お客様のみが単独で負うものとします。

上記の各種リソースは、予告なく変更される可能性があります。これらのリソースは、リソースで説明されているテキサス・インスツルメンツ製品を使用するアプリケーションの開発の目的でのみ、テキサス・インスツルメンツはその使用をお客様に許諾します。これらのリソースに関して、他の目的で複製することや掲載することは禁止されています。テキサス・インスツルメンツや第三者の知的財産権のライセンスが付与されている訳ではありません。お客様は、これらのリソースを自身で使用した結果発生するあらゆる申し立て、損害、費用、損失、責任について、テキサス・インスツルメンツおよびその代理人を完全に補償するものとし、テキサス・インスツルメンツは一切の責任を拒否します。

テキサス・インスツルメンツの製品は、[テキサス・インスツルメンツの販売条件](#)、または [ti.com](https://www.ti.com) やかかるテキサス・インスツルメンツ製品の関連資料などのいずれかを通じて提供する適用可能な条項の下で提供されています。テキサス・インスツルメンツがこれらのリソースを提供することは、適用されるテキサス・インスツルメンツの保証または他の保証の放棄の拡大や変更を意味するものではありません。

お客様がいかなる追加条項または代替条項を提案した場合でも、テキサス・インスツルメンツはそれらに異議を唱え、拒否します。

郵送先住所：Texas Instruments, Post Office Box 655303, Dallas, Texas 75265
Copyright © 2025, Texas Instruments Incorporated