

# TPDxEUSB30 2、4 チャンネル ESD 保護、Super-Speed USB 3.0 インターフェイス用

## 1 特長

- USB 3.0 のデータ・レート (5Gbps) をサポート
- IEC 61000-4-2 ESD 保護 (レベル 4 接触)
- IEC 61000-4-5 サージ保護
  - 5A (8/20 $\mu$ s)
- 低キャパシタンス
  - DRT:0.7pF (標準値)
  - DQA:0.8pF (標準値)
- 動的抵抗:0.6 $\Omega$  (標準値)
- コンパクトな DRT、DQA パッケージ
- フロースルー・ピン配置

## 2 アプリケーション

- ノートブック PC
- セット・トップ・ボックス
- DVD プレーヤ
- メディア・プレーヤ
- 携帯型コンピュータ

## 3 概要

TPD2EUSB30、TPD2EUSB30A、TPD4EUSB30 は、2 および 4 チャンネルの過渡電圧サプレッサ (TVS) を使用した静電気放電 (ESD) 保護ダイオード・アレイです。TPDxEUSB30/A デバイスは、IEC 61000-4-2 国際規格 (接触) で規定されている最大レベルの ESD 耐性を備えています。これらのデバイスは、IEC 61000-4-5 (サージ) 仕様に基づく 5A (8/20 $\mu$ s) のピーク・パルス電流定格も持っています。

TPD2EUSB30A は、4.5V の低い DC ブレークダウン電圧を持っています。その低い静電容量、低いブレークダウン電圧、低い動的抵抗により、TPD2EUSB30A は高速差動 IO に適した優れた保護デバイスと言えます。

TPD2EUSB30 と TPD2EUSB30A は、コンパクトな DRT (1mm × 1mm) パッケージで供給されます。TPD4EUSB30 は、コンパクトな DQA (2.5mm × 1.0mm) パッケージで供給されます。

### 製品情報<sup>(1)</sup>

| 部品番号        | パッケージ     | 本体サイズ (公称)      |
|-------------|-----------|-----------------|
| TPD2EUSB30  | SOT (3)   | 1.00mm × 0.80mm |
| TPD2EUSB30A |           |                 |
| TPD4EUSB30  | USON (10) | 2.50mm × 1.00mm |

(1) 利用可能なすべてのパッケージについては、このデータシートの末尾にある注文情報を参照してください。

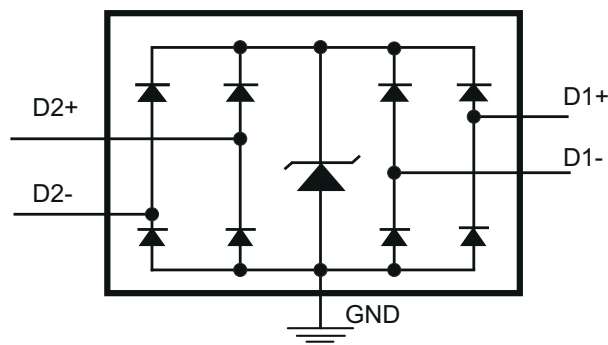

TPD4EUSB30 の回路図

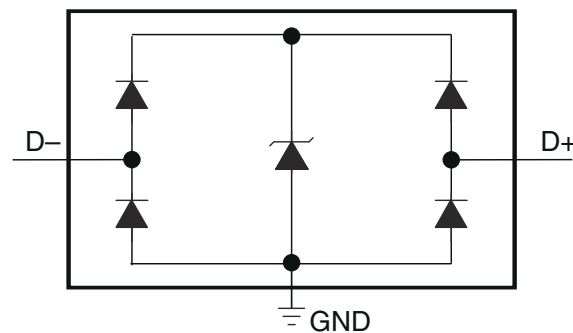

TPD2EUSB30/A の回路図



## Table of Contents

|   |          |  |           |
|---|----------|--|-----------|
| 1 特長.....                                     | 1        | 7.4 Device Functional Modes.....   | 8         |
| 2 アプリケーション.....                               | 1        | <b>8 Application and Implementation.....</b>                                 | <b>9</b>  |
| 3 概要.....                                     | 1        | 8.1 Application Information.....   | 9         |
| <b>4 Revision History.....</b>                | <b>2</b> | 8.2 Typical Application.....   | 9         |
| <b>5 Pin Configuration and Functions.....</b> | <b>3</b> | <b>9 Power Supply Recommendations.....</b>                                   | <b>11</b> |
| <b>6 Specifications.....</b>                  | <b>4</b> | <b>10 Layout.....</b>  | <b>11</b> |
| 6.1 Absolute Maximum Ratings.....             | 4        | 10.1 Layout Guidelines.....  | 11        |
| 6.2 ESD Ratings.....                          | 4        | 10.2 Layout Examples.....  | 12        |
| 6.3 Recommended Operating Conditions.....     | 4        | <b>11 Device and Documentation Support.....</b>                              | <b>14</b> |
| 6.4 Thermal Information.....                  | 4        | 11.1 Receiving Notification of Documentation Updates..                       | 14        |
| 6.5 Electrical Characteristics.....           | 5        | 11.2 サポート・リソース.....  | 14        |
| 6.6 Typical Characteristics.....              | 6        | 11.3 Trademarks.....   | 14        |
| <b>7 Detailed Description.....</b>            | <b>8</b> | 11.4 Electrostatic Discharge Caution.....                                    | 14        |
| 7.1 Overview.....                             | 8        | 11.5 Glossary.....   | 14        |
| 7.2 Functional Block Diagrams.....            | 8        | <b>12 Mechanical, Packaging, and Orderable<br/>         Information.....</b> | <b>14</b> |
| 7.3 Feature Description.....                  | 8        |  |           |

### 4 Revision History

資料番号末尾の英字は改訂を表しています。その改訂履歴は英語版に準じています。

| <b>Changes from Revision F (October 2015) to Revision G (June 2021)</b>  | <b>Page</b> |
|--|-------------|
| • 文書全体にわたって表、図、相互参照の採番方法を更新.....   | 1           |
| • Changed the <i>Pin Functions</i> table to clarify pin order and function.....  | 3           |
| <b>Changes from Revision E (August 2014) to Revision F (October 2015)</b>  | <b>Page</b> |
| • Moved the storage temperature to the <i>Absolute Maximum Ratings</i> table and updated the <i>Handling Ratings</i> table to an <i>ESD Ratings</i> table..... | 4           |
| • Added test condition frequency to capacitance .....  | 5           |
| <b>Changes from Revision D (August 2012) to Revision E (July 2014)</b>   | <b>Page</b> |
| • 「取り扱い定格」の表、「機能説明」セクション、「デバイスの機能モード」セクション、「アプリケーションと実装」セクション、「電源に関する推奨事項」セクション、「レイアウト」セクション、「デバイスおよびドキュメントのサポート」セクション、「メカニカル、パッケージ、および注文情報」セクションを追加.....      | 1           |
| <b>Changes from Revision C (December 2011) to Revision D (August 2012)</b>   | <b>Page</b> |
| • 動的抵抗値を更新.....  | 1           |
| • Updated Dynamic Resistance value.....  | 5           |
| <b>Changes from Revision B (July 2011) to Revision C (December 2011)</b>   | <b>Page</b> |
| • Added Insertion Loss graphic to TYPICAL OPERATING CHARACTERISTICS section.....   | 6           |
| <b>Changes from Revision A (December 2010) to Revision B (July 2011)</b>   | <b>Page</b> |
| • Changed TOP-SIDE MARKING column in the Ordering Information Table .....  | 3           |
| <b>Changes from Revision * (August 2010) to Revision A (December 2010)</b>   | <b>Page</b> |
| • ドキュメントに TPS2EUSB30A を追加.....   | 1           |

## 5 Pin Configuration and Functions



图 5-1. DRT Package 3-Pin SOT Top View



图 5-2. DQA Package 10-Pin USON Top View

表 5-1. Pin Functions

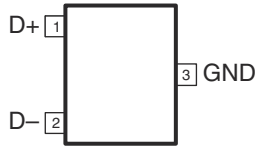
| NAME | PIN |             | TYPE     | DESCRIPTION  |
|------|-----|-------------|----------|--|
|      | DRT | DQA         |          |  |
| D1+  | 1   | 1           | ESD port | High-speed ESD clamp, provides ESD protection to the high-speed differential data lines. |
| D1-  | 2   | 2           |          |  |
| D2+  | —   | 4           |          |  |
| D2-  | —   | 5           |          |  |
| GND  | 3   | 3, 8        | GND      | Ground   |
| N.C. | —   | 6, 7, 9, 10 | —        | Not normally connected   |

## 6 Specifications

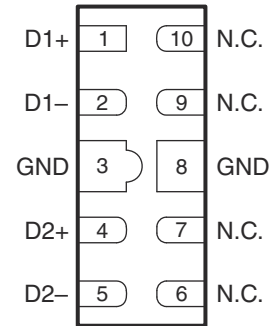
### 6.1 Absolute Maximum Ratings

over operating free-air temperature range (unless otherwise noted)<sup>(1)</sup>

|   |                                | MIN         | MAX | UNIT |
|---|--------------------------------|-------------|-----|------|
| IO voltage (D+ and D- pins)                           | TPD2EUSB30, TPD4EUSB30         | 0           | 6   | V    |
|   | TPD2EUSB30A                    | 0           | 4   |      |
| IEC 61000-4-5 surge current ( $t_p = 8/20 \mu s$ )    |                                | D+, D- pins |     | 5    |
| IEC 61000-4-5 surge peak power ( $t_p = 8/20 \mu s$ ) |                                | D+, D- pins |     | 45   |
| $T_A$   | Operating free-air temperature | -40         | 85  | °C   |
| $T_{stg}$   | Storage temperature            | -65         | 125 | °C   |

- (1) Stresses beyond those listed under Absolute Maximum Ratings may cause permanent damage to the device. These are stress ratings only, and functional operation of the device at these or any other conditions beyond those indicated in the operational sections of the specifications is not implied. Exposure to absolute maximum-rated conditions for extended periods may affect device reliability.

### 6.2 ESD Ratings

|                                     |  | VALUE       | UNIT |      |
|-------------------------------------|--|-------------|------|------|
| $V_{(ESD)}$ Electrostatic discharge | Human body model (HBM), per ANSI/ESDA/JEDEC JS-001, all pins <sup>(1)</sup>              | 2500        | V    |      |
|                                     | Charged device model (CDM), per JEDEC specification JESD22-C101, all pins <sup>(2)</sup> | 1500        |      |      |
|                                     | IEC 61000-4-2 Contact Discharge  | D+, D- pins |      | 8000 |
|                                     | IEC 61000-4-2 Air-Gap Discharge (TPD2EUSB30/A)   | D+, D- pins |      | 8000 |
|                                     | IEC 61000-4-2 Air-Gap Discharge (TPD4EUSB30)   | D+, D- pins |      | 9000 |

- (1) JEDEC document JEP155 states that 500-V HBM allows safe manufacturing with a standard ESD control process.  
 (2) JEDEC document JEP157 states that 250-V CDM allows safe manufacturing with a standard ESD control process.

### 6.3 Recommended Operating Conditions

over operating free-air temperature range (unless otherwise noted)

|                   |                                | MIN | MAX | UNIT |
|-------------------|--------------------------------|-----|-----|------|
| $T_A$             | operating free-air temperature | -40 | 85  | °C   |
| Operating Voltage | TPD2EUSB30, TPD4EUSB30         | 0   | 5.5 | V    |
|                   | TPD2EUSB30A                    | 0   | 3.6 |      |

### 6.4 Thermal Information

| THERMAL METRIC <sup>(1)</sup> |  | TPD2EUSB30 | TPD2EUSB30A | TPD4EUSB30 | UNIT |
|-------------------------------|--|------------|-------------|------------|------|
|                               |  | DRT (SOT)  | DRT (SOT)   | DQA (USON) |      |
|                               |  | 3 PINS     | 3 PINS      | 10 PINS    |      |
| $R_{\theta JA}$               | Junction-to-ambient thermal resistance       | 610.2      | 610.2       | 162.2      | °C/W |
| $R_{\theta JC(top)}$          | Junction-to-case (top) thermal resistance    | 288.0      | 288.0       | 128.3      | °C/W |
| $R_{\theta JB}$               | Junction-to-board thermal resistance         | 118.4      | 118.4       | 56.7       | °C/W |
| $\psi_{JT}$                   | Junction-to-top characterization parameter   | 20.2       | 20.2        | 13.8       | °C/W |
| $\psi_{JB}$                   | Junction-to-board characterization parameter | 116.4      | 116.4       | 56.6       | °C/W |
| $R_{\theta JC(bot)}$          | Junction-to-case (bottom) thermal resistance | N/A        | N/A         | 8.1        | °C/W |

- (1) For more information about traditional and new thermal metrics, see the *Semiconductor and IC Package Thermal Metrics* application report, [SPRA953](#).

## 6.5 Electrical Characteristics

over operating free-air temperature range (unless otherwise noted)

| PARAMETER    |  | TEST CONDITIONS   | MIN                             | TYP  | MAX  | UNIT     |
|--------------|--|---|---------------------------------|------|------|----------|
| $V_{RWM}$    | Reverse stand-off voltage (D+ and D- pins) | TPD2EUSB30, TPD4EUSB30  |                                 |      | 5.5  | V        |
|              |  | TPD2EUSB30A   |                                 |      | 3.6  | V        |
| $V_{clamp}$  | Clamp voltage                              | D+,D- pins to ground, $I_{IO} = 1$ A                          |                                 |      | 8    | V        |
| $I_{IO}$     | Current from IO port to supply pins        | $V_{IO} = 2.5$ V, $I_D = 8$ mA                                |                                 | 0.01 | 0.1  | $\mu$ A  |
| $V_D$        | Diode forward voltage                      | D+,D- pins, lower clamp diode, $V_{IO} = 2.5$ V, $I_D = 8$ mA | 0.6                             | 0.8  | 0.95 | V        |
| $R_{dyn}$    | Dynamic resistance                         | D+,D- pins $I = 1$ A  |                                 | 0.6  |      | $\Omega$ |
| $C_{IO-IO}$  | Capacitance IO to IO                       | D+,D- pins $V_{IO} = 2.5$ V; $f = 100$ kHz                    |                                 | 0.05 |      | pF       |
| $C_{IO-GND}$ | Capacitance IO to GND                      | D+,D- pins (DRT)  |                                 | 0.7  |      | pF       |
|              |  | D1+, D1-, D2+, D2- (DQA)                                      | $V_{IO} = 2.5$ V; $f = 100$ kHz | 0.8  |      |          |
| $V_{BR}$     | Break-down voltage, TPD2EUSB30, TPD4EUSB30 | $I_{IO} = 1$ mA   |                                 | 7    |      | V        |
|              | Break-down voltage, TPD2EUSB30A            | $I_{IO} = 1$ mA   |                                 | 4.5  |      | V        |

## 6.6 Typical Characteristics

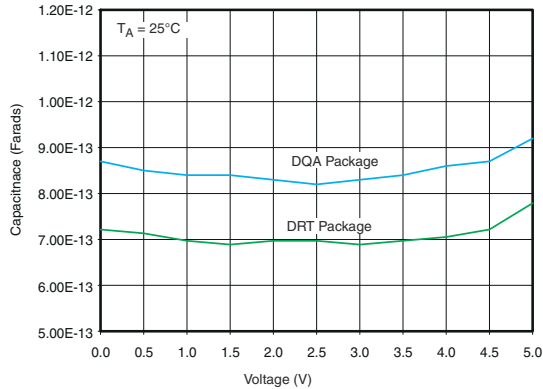

$T_A = 25^\circ\text{C}$

**6-1. IO Capacitance vs IO Voltage**

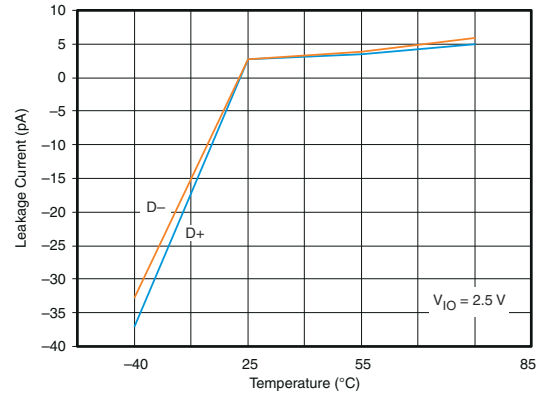

$V_{IO} = 2.5\text{ V}$

**6-2. Leakage Current vs Temperature**

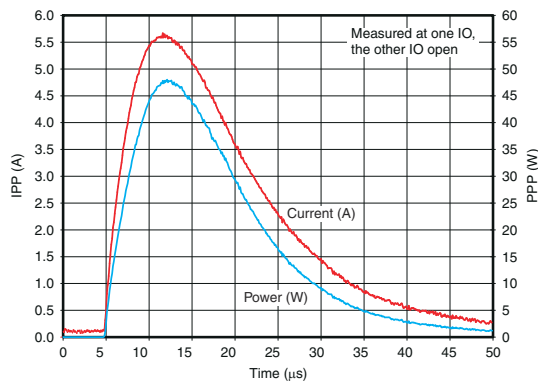

Measured at one IO, the other IO open

**6-3. Peak Pulse Waveforms**

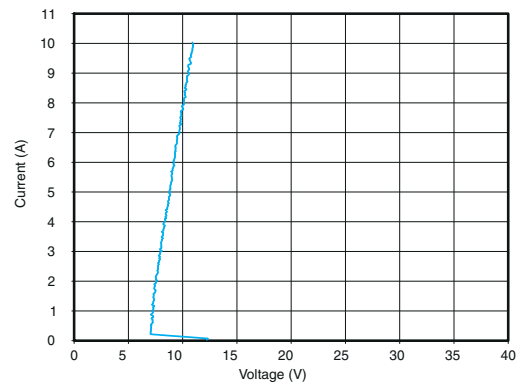

**6-4. D+, D- Transmission Line Pulsar Plot for TPD2EUSB30  
(100 ns Pulse, 10 ns Rise Time)**

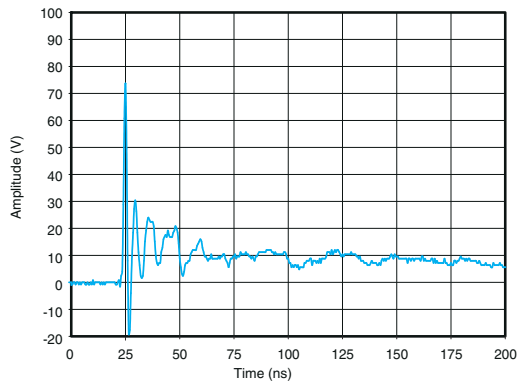

**6-5. IEC Clamping Waveforms (8 kV Contact)**

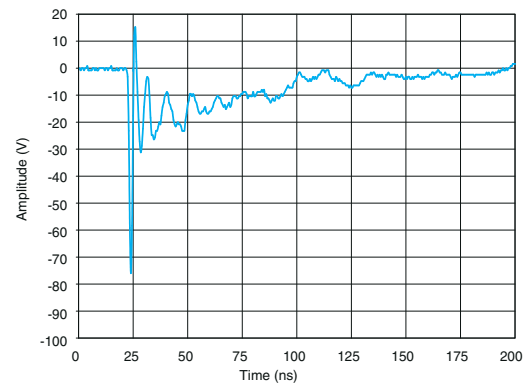

**6-6. IEC Clamping Waveforms (-8 kV Contact)**

## 6.6 Typical Characteristics (continued)

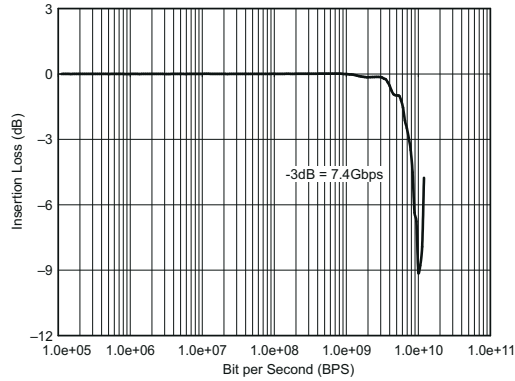

-3 dB = 7.4 Gbps

**6-7. Insertion Loss**

## 7 Detailed Description

### 7.1 Overview

The TPD2EUSB30, TPD2EUSB30A, and TPD4EUSB30 are 2 and 4 channel Transient Voltage Suppressor (TVS) based Electrostatic Discharge (ESD) protection diode arrays. The TPDxEUSB30/A devices are rated to dissipate ESD strikes at the maximum contact level specified in the IEC 61000-4-2 international standard (Contact). These devices also offer 5 A (8/20  $\mu$ s) peak pulse current ratings per IEC 61000-4-5 (surge) specification.

### 7.2 Functional Block Diagrams

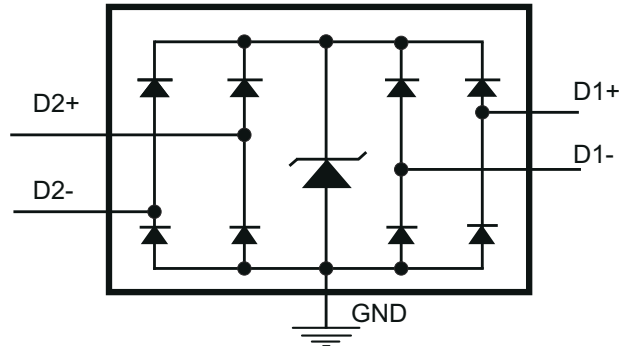

7-1. TPD4EUSB30 Circuit

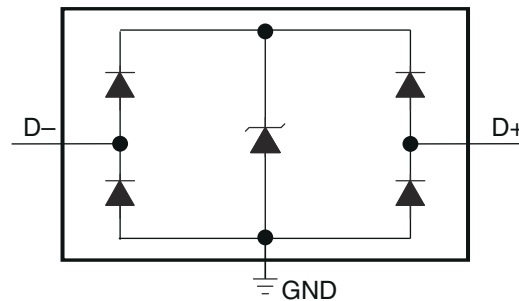

7-2. TPD2EUSB30/A Circuit

### 7.3 Feature Description

TPDxEUSB30/A is a family of uni-directional Electrostatic Discharge (ESD) protection devices with low capacitance. Each IO line is rated to dissipate ESD strikes at or above the maximum level specified in the IEC 61000-4-2 (Level 4 Contact) international standard. The TPDxEUSB30/A's low loading capacitance makes it ideal for protection super speed high-speed signals.

### 7.4 Device Functional Modes

The TPDxEUSB30/A family of devices are passive integrated circuits that activate whenever voltages above  $V_{BR}$  or below the lower diodes  $V_{forward}$  ( $-0.6V$ ) are present upon the circuit being protected. During ESD events, voltages as high as  $\pm 8$  kV (contact) can be directed to ground via the internal diode network. Once the voltages on the protected lines fall below the trigger voltage of the device (usually within 10's of nano-seconds) the device reverts to passive.



## 8 Application and Implementation

### Note

以下のアプリケーション情報は、TI の製品仕様に含まれるものではなく、TI ではその正確性または完全性を保証いたしません。個々の目的に対する製品の適合性については、お客様の責任で判断していただくこととなります。お客様は自身の設計実装を検証しテストすることで、システムの機能を確認する必要があります。

### 8.1 Application Information

The TPDxEUSB30/A family is a family of diode array type transient voltage suppressors (TVS) which are typically used to provide a path to ground for dissipating ESD events on hi-speed signal lines between a human interface connector and a system. As the current from ESD passes through the TVS, only a small voltage drop is present across the diode. This is the voltage presented to the protected IC. The low  $R_{DYN}$  of the triggered TVS holds this voltage,  $V_{CLAMP}$ , to a tolerable level to the protected IC.

### 8.2 Typical Application

This application describes a TPDxEUSB30/A eye pattern test. 図 10-2 shows the lab board that was designed to demonstrate the degradation of the eye pattern quality with and without the TPD2EUSB30/A in the USB 3.0 signal path. The measurements show that there is only ~2 ps jitter penalty to the differential signal when the TPD2EUSB30/A device is added in the signal path. A similar setup was employed to measure the eye diagram for the TPD4EUSB30.



図 8-1. Measurement Setup to collect the Eye Pattern on a Reference Board with TPD2EUSB30/A



図 8-2. Measurement Setup to collect the Eye Pattern on a Reference Board with TPD2EUSB30/A

#### 8.2.1 Design Requirements

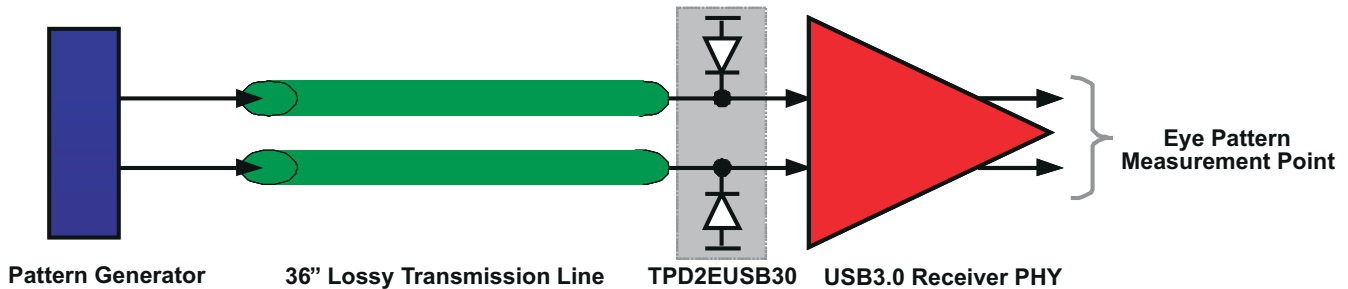
For this design example, a single TPD2EUSB30/A is used to protect a differential data pair lines, similar to a USB 3.0 application. Given the USB application, the following parameters are known.

表 8-1. Design Parameters

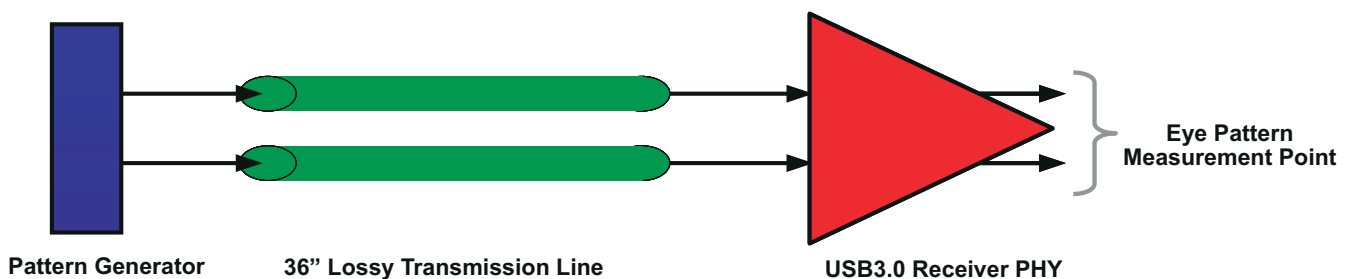
| DESIGN PARAMETER           | VALUE        |
|----------------------------|--------------|
| Signal range on D+, and D- | 0 V to 3.3 V |
| Operating Frequency        | 2.5 GHz      |

## 8.2.2 Detailed Design Procedure

To begin the design process, some parameters must be decided upon; the designer needs to know the following:

- Signal range on all the protected lines
- Operating frequency

### 8.2.2.1 Signal Range on D+, D- Pins

The TPD2EUSB30 has 2 pins which support 0 to 5.5 V and the TPD2EUSB30A has 2 pins which support 0 to 3.6 V.

### 8.2.2.2 Operating Frequency

The 0.7 pF (TPD2EUSB30/A typ) line capacitance supports data rates in excess of 5 Gbps.

## 8.2.3 Application Curves

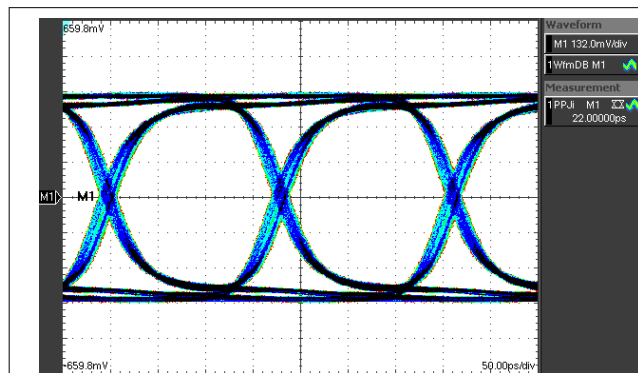

Figure 8-3. Output Eye Diagram Without TPD2EUSB30/A (Figure 8-2 Setup, 5 Gbps Data Rate)

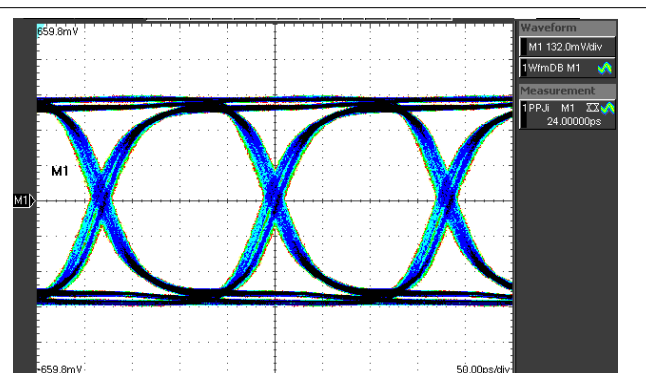

Figure 8-4. Output Eye Diagram With the TPD2EUSB30/A (Figure 8-2 Setup, 5 Gbps Data Rate)

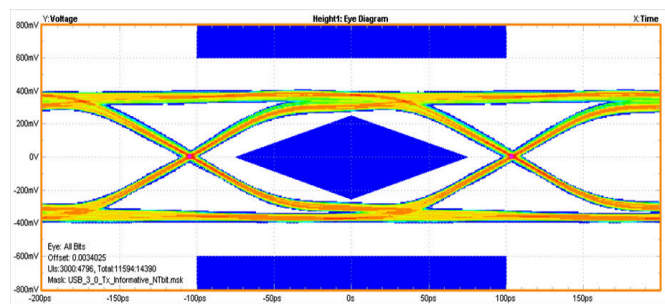

Figure 8-5. Output Eye Diagram Without the TPD4EUSB30 (5 Gbps Data Rate)

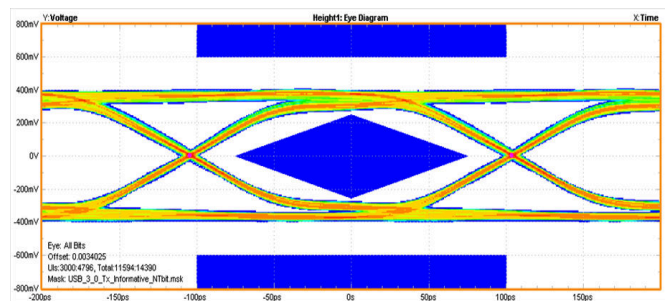

Figure 8-6. Output Eye Diagram with the TPD4EUSB30 (5 Gbps Data Rate)

## 9 Power Supply Recommendations

This family of devices are passive ESD protection devices and there is no need to power them. Care should be taken to not violate the maximum voltage specification to ensure that the device functions properly. The D+ and D– lines share a TVS diode which can tolerate up to 6 V.

## 10 Layout

### 10.1 Layout Guidelines

- The optimum placement is as close to the connector as possible.
  - EMI during an ESD event can couple from the trace being struck to other nearby unprotected traces, resulting in early system failures.
  - The PCB designer needs to minimize the possibility of EMI coupling by keeping any unprotected traces away from the protected traces which are between the TVS and the connector.
- Route the protected traces as straight as possible.
- Eliminate any sharp corners on the protected traces between the TVS and the connector by using rounded corners with the largest radii possible.
  - Electric fields tend to build up on corners, increasing EMI coupling.

Refer to [Figure 10-1](#), the TPD2EUSB30/A are offered in space saving DRT package. The DRT is a 1-mm × 1-mm package with flow-through pin-mapping for the high-speed differential lines. The TPD4EUSB30 is offered in space saving DQA package. The DQA is a 1-mm × 2.5-mm package with flow-through pin-mapping for the high-speed differential lines. It is recommended to place the package right next to the USB 3.0 connector. The GND pin should be connected to GND plane of the board through a large VIA. If a dedicated GND plane is not present right underneath, it is recommended to route to the GND plane through a wide trace. The current associated with IEC ESD stress can be in the range of 30Amps or higher momentarily. A good, low impedance GND path ensures the system robustness against IEC ESD stress.

The TPDxEUSB30/A can provide system level ESD protection to the high-speed differential ports (> 5 Gbps data rate). The flow-through package offers flexibility for board routing with traces up to 15 mills wide. It allows the differential signal pairs couple together right after they touch the ESD ports of the TPDxEUSB30/A.

## 10.2 Layout Examples

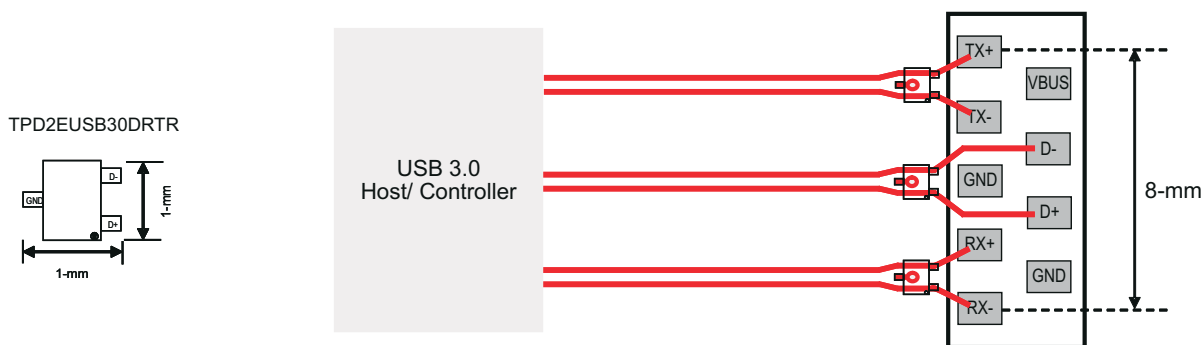

Three TPD2EUSB30 to Protect USB3.0 Class A connector (One Layer Routing)

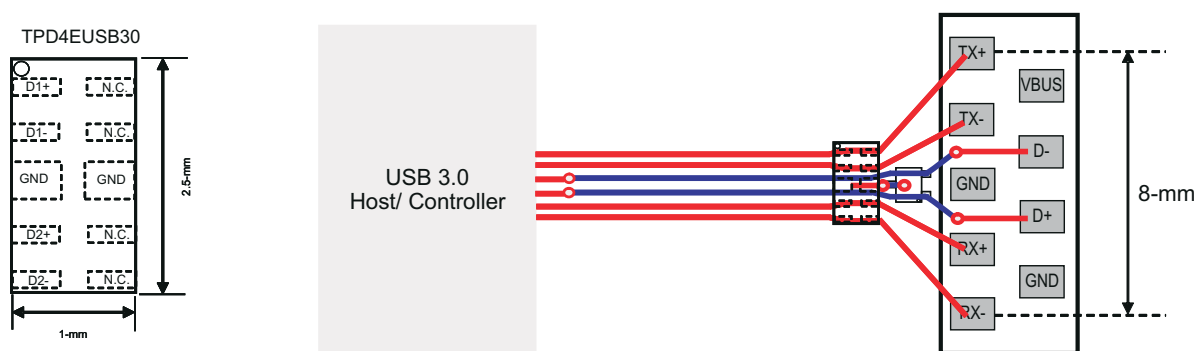

One TPD4EUSB30 & One TPD2EUSB30 to Protect USB3.0 Class A connector (Two Layer Routing)

 **10-1. TPDxUSB30/A at the USB3.0 Class A Connector**

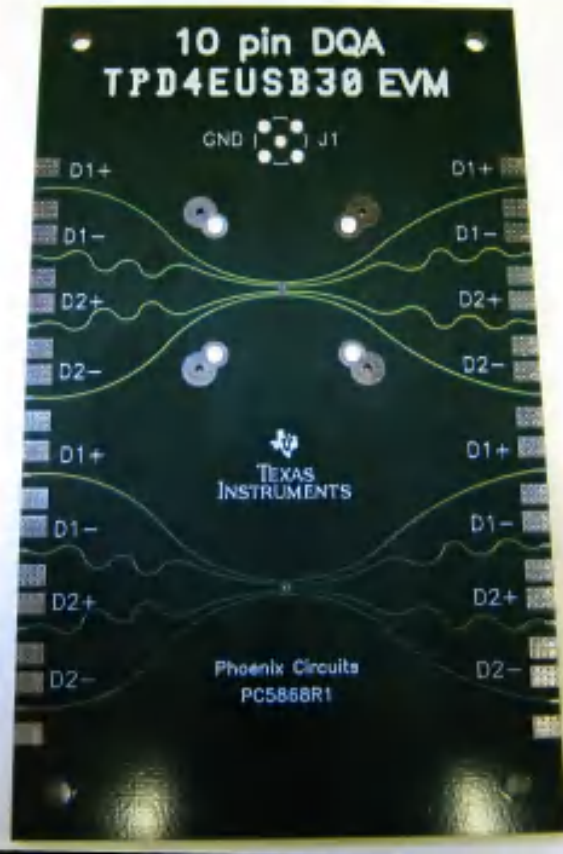

10-2. TPDxUSB30/A EVM – TPD4EUSB30 Side

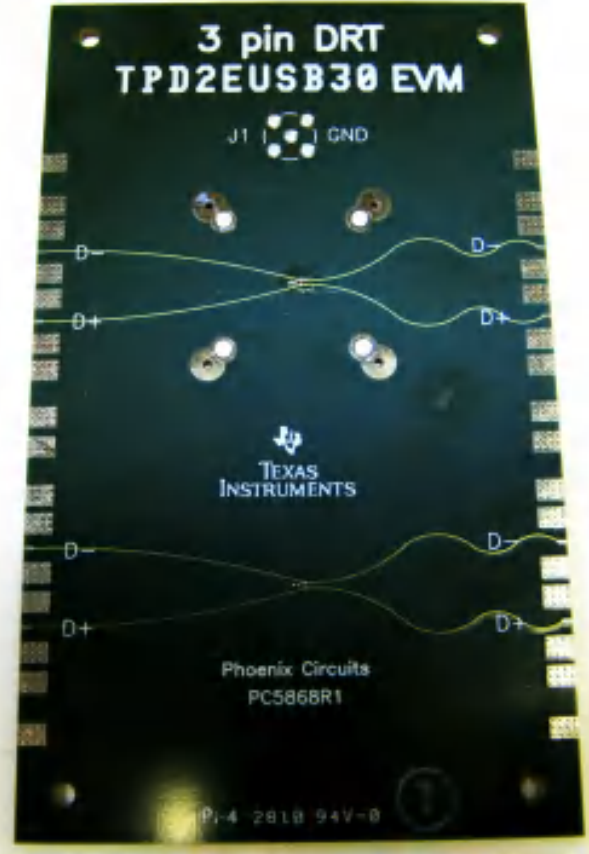

10-3. TPDxUSB30/A EVM – TPD2EUSB30/A Side

## 11 Device and Documentation Support

### 11.1 Receiving Notification of Documentation Updates

To receive notification of documentation updates, navigate to the device product folder on [ti.com](https://www.ti.com). Click on *Subscribe to updates* to register and receive a weekly digest of any product information that has changed. For change details, review the revision history included in any revised document.

### 11.2 サポート・リソース

TI E2E™ サポート・フォーラムは、エンジニアが検証済みの回答と設計に関するヒントをエキスパートから迅速かつ直接得ることができる場所です。既存の回答を検索したり、独自の質問をしたりすることで、設計に必要な支援を迅速に得ることができます。

リンクされているコンテンツは、該当する貢献者により、現状のまま提供されるものです。これらは TI の仕様を構成するものではなく、必ずしも TI の見解を反映したものではありません。TI の [使用条件](#) を参照してください。

### 11.3 Trademarks

TI E2E™ is a trademark of Texas Instruments.

すべての商標は、それぞれの所有者に帰属します。

### 11.4 Electrostatic Discharge Caution



This integrated circuit can be damaged by ESD. Texas Instruments recommends that all integrated circuits be handled with appropriate precautions. Failure to observe proper handling and installation procedures can cause damage.

ESD damage can range from subtle performance degradation to complete device failure. Precision integrated circuits may be more susceptible to damage because very small parametric changes could cause the device not to meet its published specifications.

### 11.5 Glossary

[TI Glossary](#) This glossary lists and explains terms, acronyms, and definitions.

## 12 Mechanical, Packaging, and Orderable Information

The following pages include mechanical, packaging, and orderable information. This information is the most current data available for the designated devices. This data is subject to change without notice and revision of this document. For browser-based versions of this data sheet, refer to the left-hand navigation.

**PACKAGING INFORMATION**

| Orderable part number           | Status<br>(1) | Material type<br>(2) | Package   Pins    | Package qty   Carrier | RoHS<br>(3) | Lead finish/<br>Ball material<br>(4) | MSL rating/<br>Peak reflow<br>(5) | Op temp (°C) | Part marking<br>(6)                |
|---------------------------------|---------------|----------------------|-------------------|-----------------------|-------------|--------------------------------------|-----------------------------------|--------------|------------------------------------|
| <a href="#">TPD2EUSB30ADRTR</a> | Active        | Production           | SOT-9X3 (DRT)   3 | 3000   LARGE T&R      | Yes         | NIPDAU                               | Level-1-260C-UNLIM                | -40 to 85    | 5S                                 |
| TPD2EUSB30ADRTR.B               | Active        | Production           | SOT-9X3 (DRT)   3 | 3000   LARGE T&R      | Yes         | NIPDAU                               | Level-1-260C-UNLIM                | -40 to 85    | 5S                                 |
| TPD2EUSB30ADRTRG4               | Active        | Production           | SOT-9X3 (DRT)   3 | 3000   LARGE T&R      | Yes         | NIPDAU                               | Level-1-260C-UNLIM                | -40 to 85    | 5S                                 |
| TPD2EUSB30ADRTRG4.B             | Active        | Production           | SOT-9X3 (DRT)   3 | 3000   LARGE T&R      | Yes         | NIPDAU                               | Level-1-260C-UNLIM                | -40 to 85    | 5S                                 |
| <a href="#">TPD2EUSB30DRTR</a>  | Active        | Production           | SOT-9X3 (DRT)   3 | 3000   LARGE T&R      | Yes         | NIPDAU                               | Level-1-260C-UNLIM                | -40 to 85    | 5P                                 |
| TPD2EUSB30DRTR.B                | Active        | Production           | SOT-9X3 (DRT)   3 | 3000   LARGE T&R      | Yes         | NIPDAU                               | Level-1-260C-UNLIM                | -40 to 85    | 5P                                 |
| TPD2EUSB30DRTRG4                | Active        | Production           | SOT-9X3 (DRT)   3 | 3000   LARGE T&R      | Yes         | NIPDAU                               | Level-1-260C-UNLIM                | -40 to 85    | 5P                                 |
| TPD2EUSB30DRTRG4.B              | Active        | Production           | SOT-9X3 (DRT)   3 | 3000   LARGE T&R      | Yes         | NIPDAU                               | Level-1-260C-UNLIM                | -40 to 85    | 5P                                 |
| <a href="#">TPD4EUSB30DQAR</a>  | Active        | Production           | USON (DQA)   10   | 3000   LARGE T&R      | Yes         | NIPDAU   NIPDAUAG                    | Level-1-260C-UNLIM                | -40 to 85    | (667, 66O, 66R, 66<br>V, BMR, CE5) |
| TPD4EUSB30DQAR.B                | Active        | Production           | USON (DQA)   10   | 3000   LARGE T&R      | Yes         | NIPDAU                               | Level-1-260C-UNLIM                | -40 to 85    | (667, 66O, 66R, 66<br>V, BMR, CE5) |
| TPD4EUSB30DQARG4                | Active        | Production           | USON (DQA)   10   | 3000   LARGE T&R      | Yes         | NIPDAU                               | Level-1-260C-UNLIM                | -40 to 85    | CE5                                |
| TPD4EUSB30DQARG4.B              | Active        | Production           | USON (DQA)   10   | 3000   LARGE T&R      | Yes         | NIPDAU                               | Level-1-260C-UNLIM                | -40 to 85    | CE5                                |

(1) **Status:** For more details on status, see our [product life cycle](#).

(2) **Material type:** When designated, preproduction parts are prototypes/experimental devices, and are not yet approved or released for full production. Testing and final process, including without limitation quality assurance, reliability performance testing, and/or process qualification, may not yet be complete, and this item is subject to further changes or possible discontinuation. If available for ordering, purchases will be subject to an additional waiver at checkout, and are intended for early internal evaluation purposes only. These items are sold without warranties of any kind.

(3) **RoHS values:** Yes, No, RoHS Exempt. See the [TI RoHS Statement](#) for additional information and value definition.

(4) **Lead finish/Ball material:** Parts may have multiple material finish options. Finish options are separated by a vertical ruled line. Lead finish/Ball material values may wrap to two lines if the finish value exceeds the maximum column width.

(5) **MSL rating/Peak reflow:** The moisture sensitivity level ratings and peak solder (reflow) temperatures. In the event that a part has multiple moisture sensitivity ratings, only the lowest level per JEDEC standards is shown. Refer to the shipping label for the actual reflow temperature that will be used to mount the part to the printed circuit board.

(6) **Part marking:** There may be an additional marking, which relates to the logo, the lot trace code information, or the environmental category of the part.

Multiple part markings will be inside parentheses. Only one part marking contained in parentheses and separated by a "~" will appear on a part. If a line is indented then it is a continuation of the previous line and the two combined represent the entire part marking for that device.

**Important Information and Disclaimer:** The information provided on this page represents TI's knowledge and belief as of the date that it is provided. TI bases its knowledge and belief on information provided by third parties, and makes no representation or warranty as to the accuracy of such information. Efforts are underway to better integrate information from third parties. TI has taken and continues to take reasonable steps to provide representative and accurate information but may not have conducted destructive testing or chemical analysis on incoming materials and chemicals. TI and TI suppliers consider certain information to be proprietary, and thus CAS numbers and other limited information may not be available for release.

In no event shall TI's liability arising out of such information exceed the total purchase price of the TI part(s) at issue in this document sold by TI to Customer on an annual basis.



**TAPE AND REEL INFORMATION**

**QUADRANT ASSIGNMENTS FOR PIN 1 ORIENTATION IN TAPE**

\*All dimensions are nominal

| Device            | Package Type | Package Drawing | Pins | SPQ  | Reel Diameter (mm) | Reel Width W1 (mm) | A0 (mm) | B0 (mm) | K0 (mm) | P1 (mm) | W (mm) | Pin1 Quadrant |
|-------------------|--------------|-----------------|------|------|--------------------|--------------------|---------|---------|---------|---------|--------|---------------|
| TPD2EUSB30ADRTR   | SOT-9X3      | DRT             | 3    | 3000 | 180.0              | 8.4                | 1.16    | 1.16    | 0.63    | 4.0     | 8.0    | Q3            |
| TPD2EUSB30ADRTRG4 | SOT-9X3      | DRT             | 3    | 3000 | 180.0              | 8.4                | 1.16    | 1.16    | 0.63    | 4.0     | 8.0    | Q3            |
| TPD2EUSB30DRTR    | SOT-9X3      | DRT             | 3    | 3000 | 180.0              | 8.4                | 1.16    | 1.16    | 0.63    | 4.0     | 8.0    | Q3            |
| TPD2EUSB30DRTRG4  | SOT-9X3      | DRT             | 3    | 3000 | 180.0              | 8.4                | 1.16    | 1.16    | 0.63    | 4.0     | 8.0    | Q3            |
| TPD4EUSB30DQAR    | USON         | DQA             | 10   | 3000 | 180.0              | 8.4                | 1.2     | 2.7     | 0.63    | 4.0     | 8.0    | Q1            |
| TPD4EUSB30DQARG4  | USON         | DQA             | 10   | 3000 | 180.0              | 8.4                | 1.2     | 2.7     | 0.63    | 4.0     | 8.0    | Q1            |

**TAPE AND REEL BOX DIMENSIONS**

\*All dimensions are nominal

| Device            | Package Type | Package Drawing | Pins | SPQ  | Length (mm) | Width (mm) | Height (mm) |
|-------------------|--------------|-----------------|------|------|-------------|------------|-------------|
| TPD2EUSB30ADRTR   | SOT-9X3      | DRT             | 3    | 3000 | 183.0       | 183.0      | 20.0        |
| TPD2EUSB30ADRTRG4 | SOT-9X3      | DRT             | 3    | 3000 | 183.0       | 183.0      | 20.0        |
| TPD2EUSB30DRTR    | SOT-9X3      | DRT             | 3    | 3000 | 183.0       | 183.0      | 20.0        |
| TPD2EUSB30DRTRG4  | SOT-9X3      | DRT             | 3    | 3000 | 183.0       | 183.0      | 20.0        |
| TPD4EUSB30DQAR    | USON         | DQA             | 10   | 3000 | 210.0       | 185.0      | 35.0        |
| TPD4EUSB30DQARG4  | USON         | DQA             | 10   | 3000 | 210.0       | 185.0      | 35.0        |

## GENERIC PACKAGE VIEW

**DQA 10**

**USON - 0.55 mm max height**

1 x 2.5, 0.5 mm pitch

PLASTIC SMALL OUTLINE - NO LEAD

This image is a representation of the package family, actual package may vary.  
Refer to the product data sheet for package details.

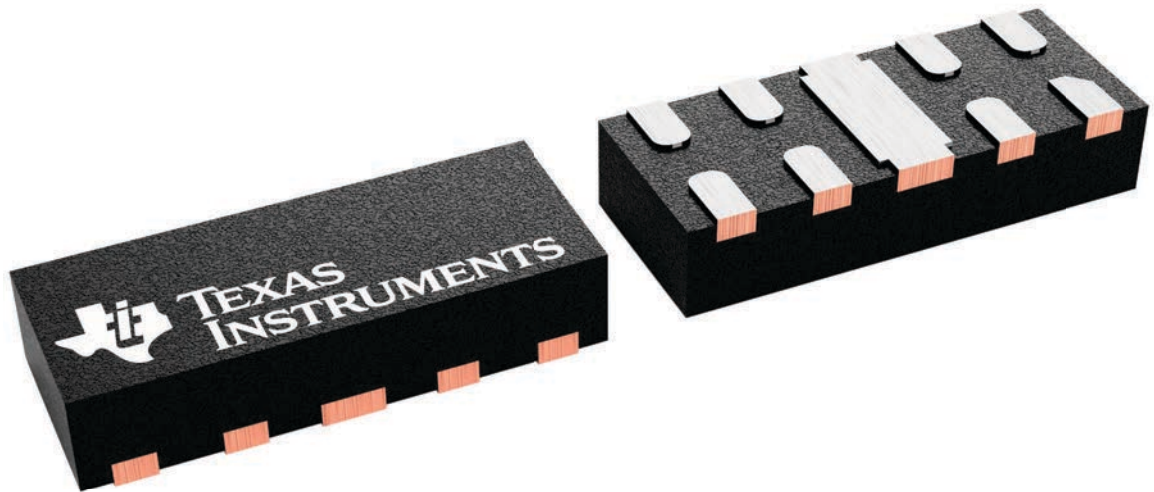

4230320/A



# EXAMPLE BOARD LAYOUT

DQA0010A

USON - 0.55 mm max height

PLASTIC SMALL OUTLINE - NO LEAD

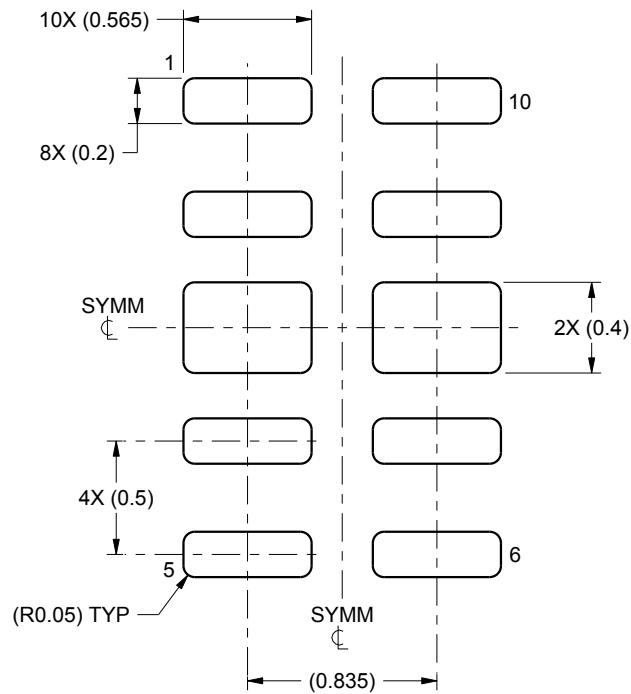

LAND PATTERN EXAMPLE  
SCALE:30X

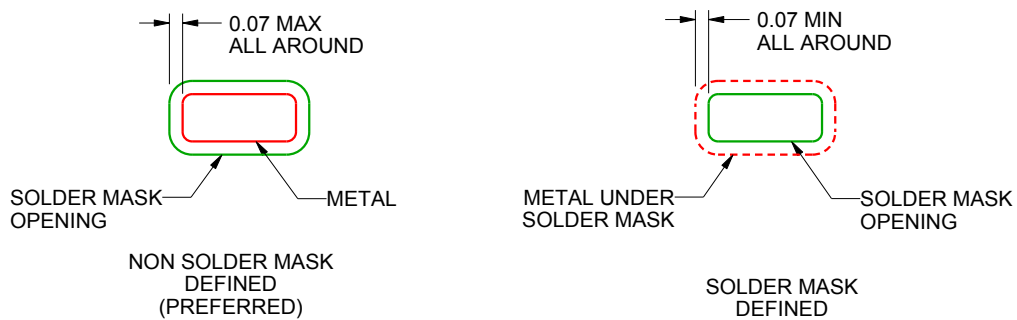

SOLDER MASK DETAILS

4220328/A 12/2015

NOTES: (continued)

3. For more information, see Texas Instruments literature number SLUA271 ([www.ti.com/lit/slua271](http://www.ti.com/lit/slua271)).

# EXAMPLE STENCIL DESIGN

DQA0010A

USON - 0.55 mm max height

PLASTIC SMALL OUTLINE - NO LEAD

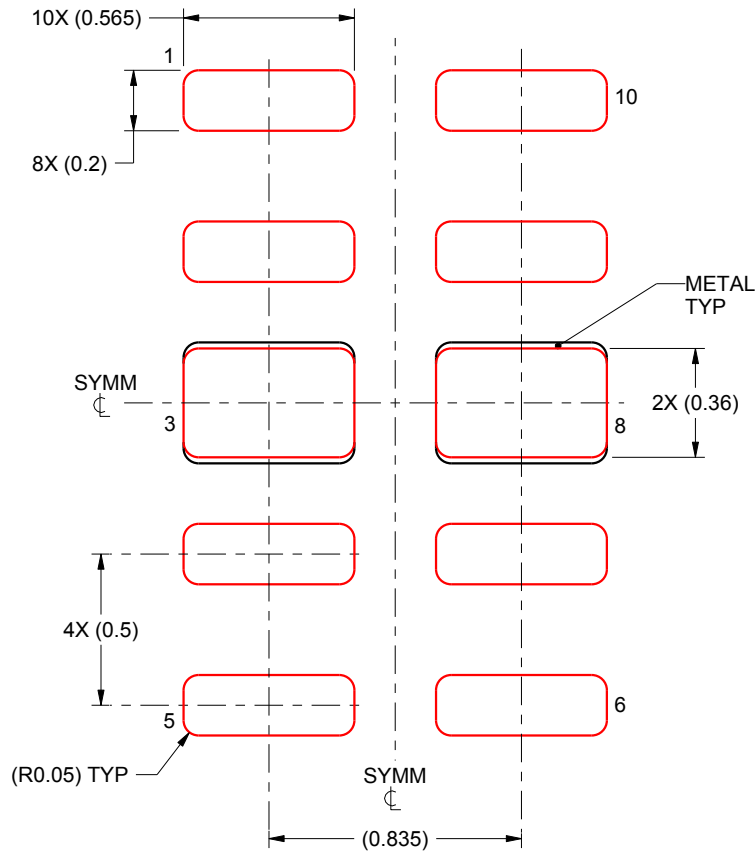

SOLDER PASTE EXAMPLE  
BASED ON 0.1 mm THICK STENCIL

EXPOSED PADS 3 & 8:  
90% PRINTED SOLDER COVERAGE BY AREA UNDER PACKAGE  
SCALE:40X

4220328/A 12/2015

NOTES: (continued)

4. Laser cutting apertures with trapezoidal walls and rounded corners may offer better paste release. IPC-7525 may have alternate design recommendations.

# DQA0010B



# PACKAGE OUTLINE

USON - 0.55 mm max height

PLASTIC SMALL OUTLINE - NO LEAD

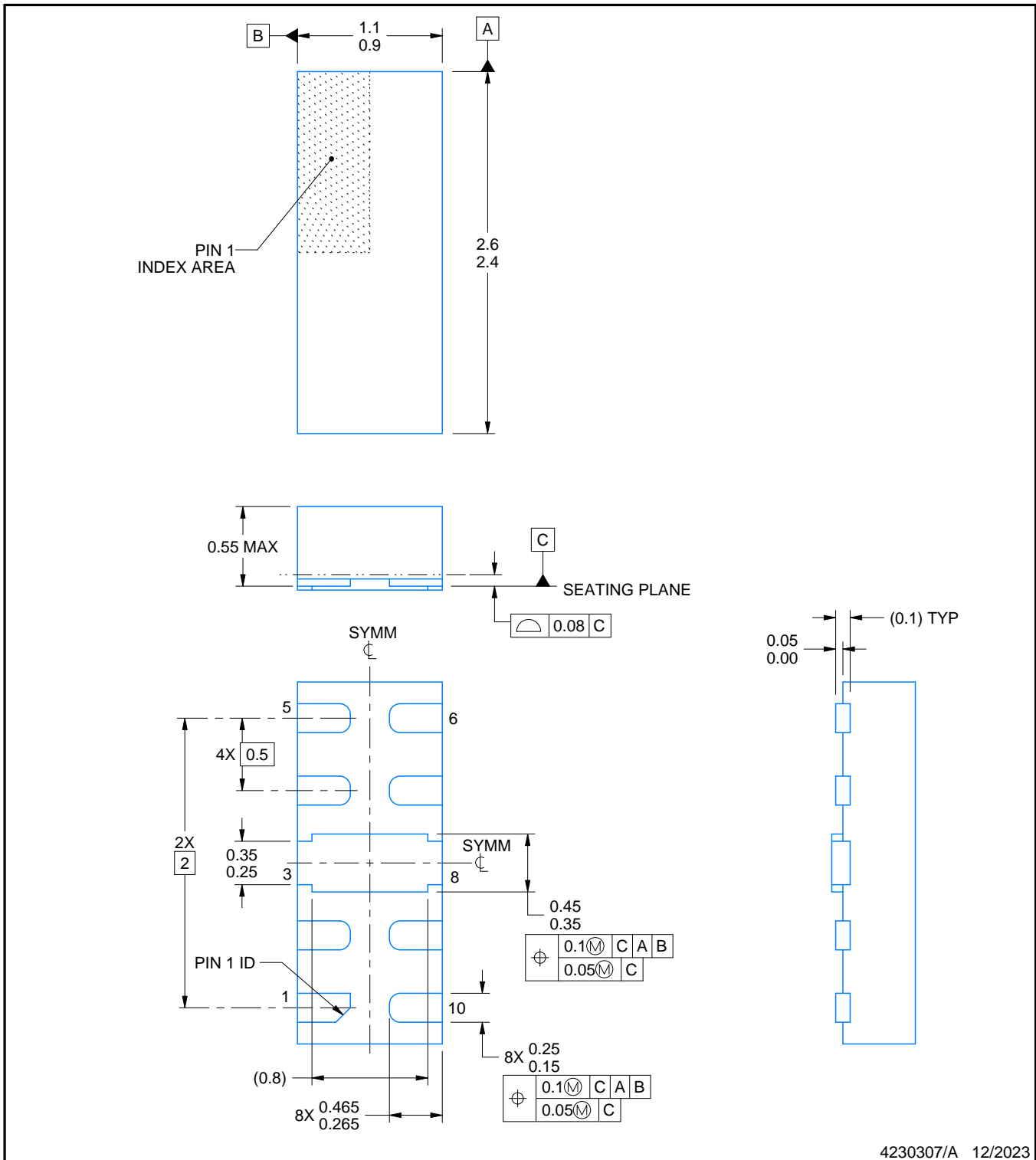

**NOTES:**

1. All linear dimensions are in millimeters. Any dimensions in parenthesis are for reference only. Dimensioning and tolerancing per ASME Y14.5M.
2. This drawing is subject to change without notice.

# EXAMPLE BOARD LAYOUT

DQA0010B

USON - 0.55 mm max height

PLASTIC SMALL OUTLINE - NO LEAD

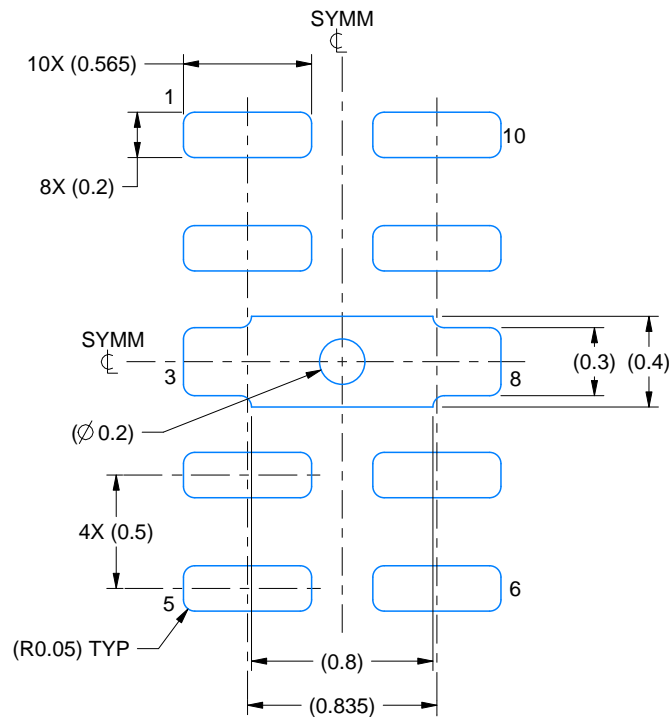

LAND PATTERN EXAMPLE  
EXPOSED METAL SHOWN  
SCALE:30X

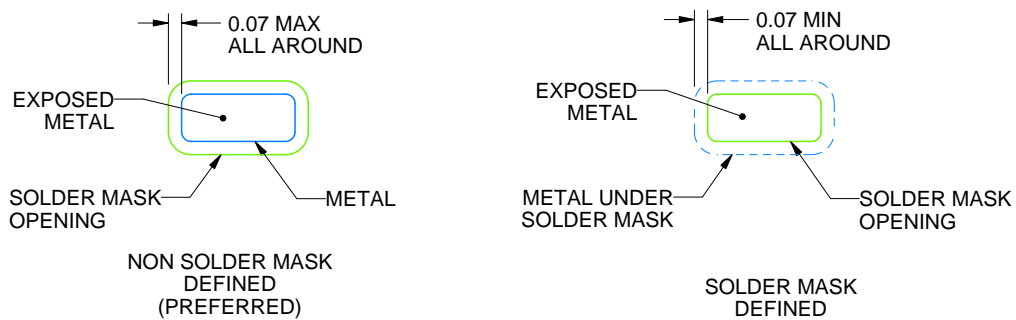

SOLDER MASK DETAILS

4230307/A 12/2023

NOTES: (continued)

3. For more information, see Texas Instruments literature number SLUA271 ([www.ti.com/lit/slua271](http://www.ti.com/lit/slua271)).



# EXAMPLE STENCIL DESIGN

DQA0010B

USON - 0.55 mm max height

PLASTIC SMALL OUTLINE - NO LEAD

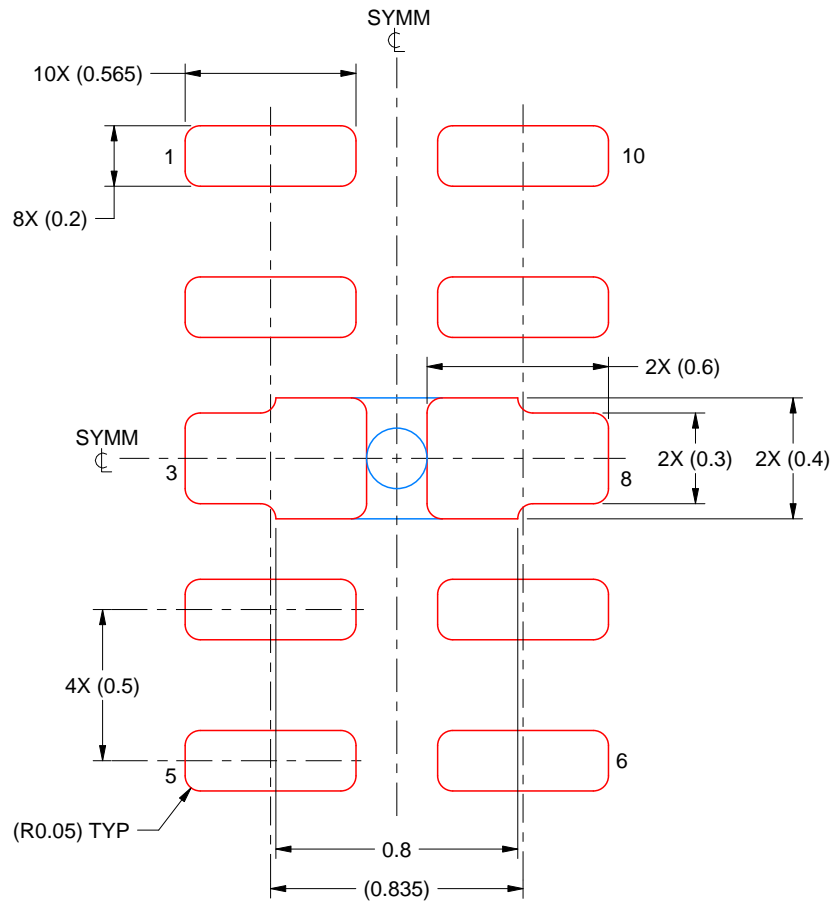

SOLDER PASTE EXAMPLE  
BASED ON 0.1 mm THICK STENCIL  
SCALE:40X

4230307/A 12/2023

NOTES: (continued)

4. Laser cutting apertures with trapezoidal walls and rounded corners may offer better paste release. IPC-7525 may have alternate design recommendations.

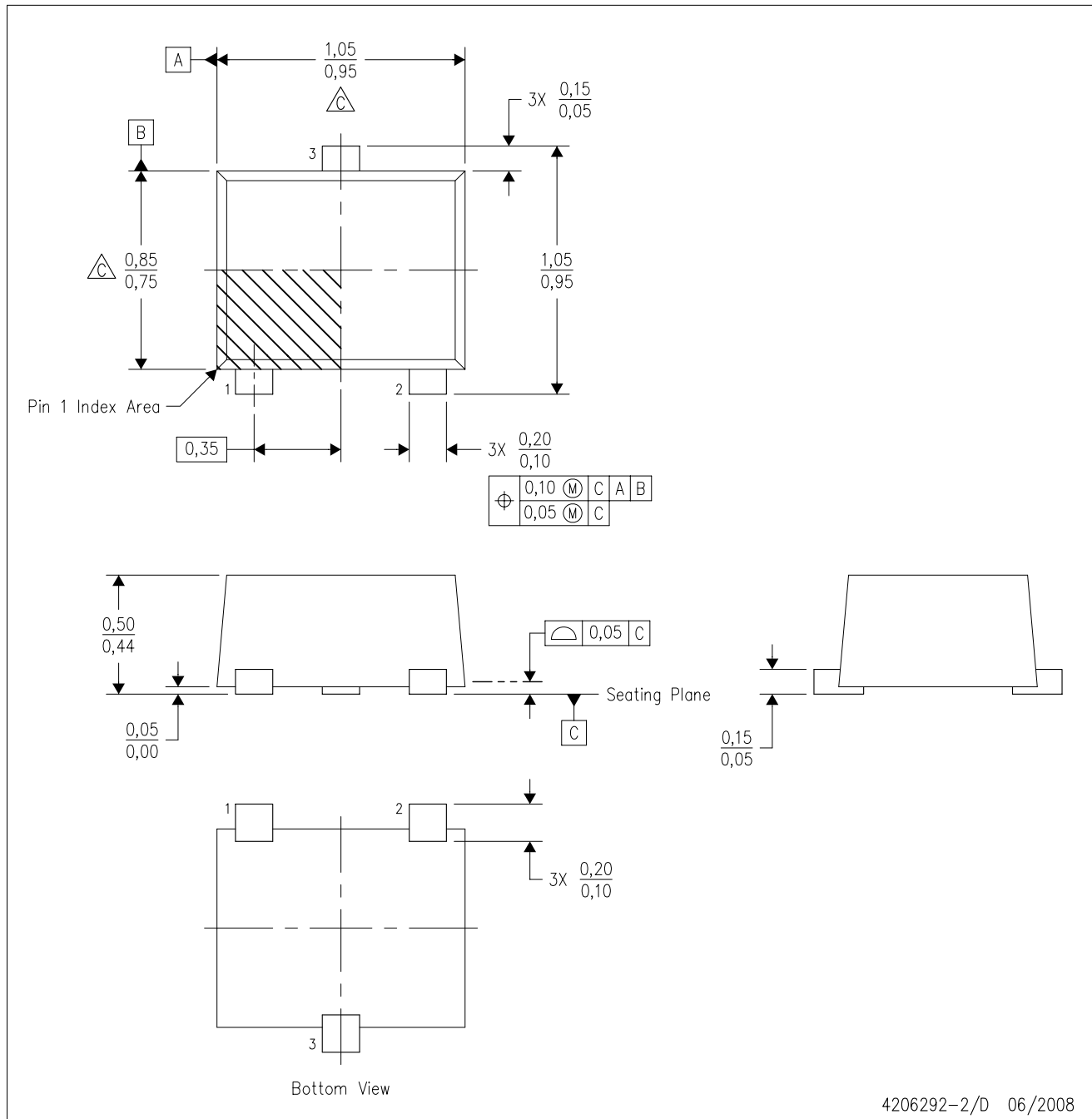

- NOTES:
- A. All linear dimensions are in millimeters. Dimensioning and tolerancing per ASME Y14.5M-1994.
  - B. This drawing is subject to change without notice.
  - $\triangle C$  Body dimensions do not include mold flash, interlead flash, protrusions, or gate burrs. Mold flash, interlead flash, protrusions, or gate burrs shall not exceed 0,10 per end or side.
  - D. JEDEC package registration is pending.

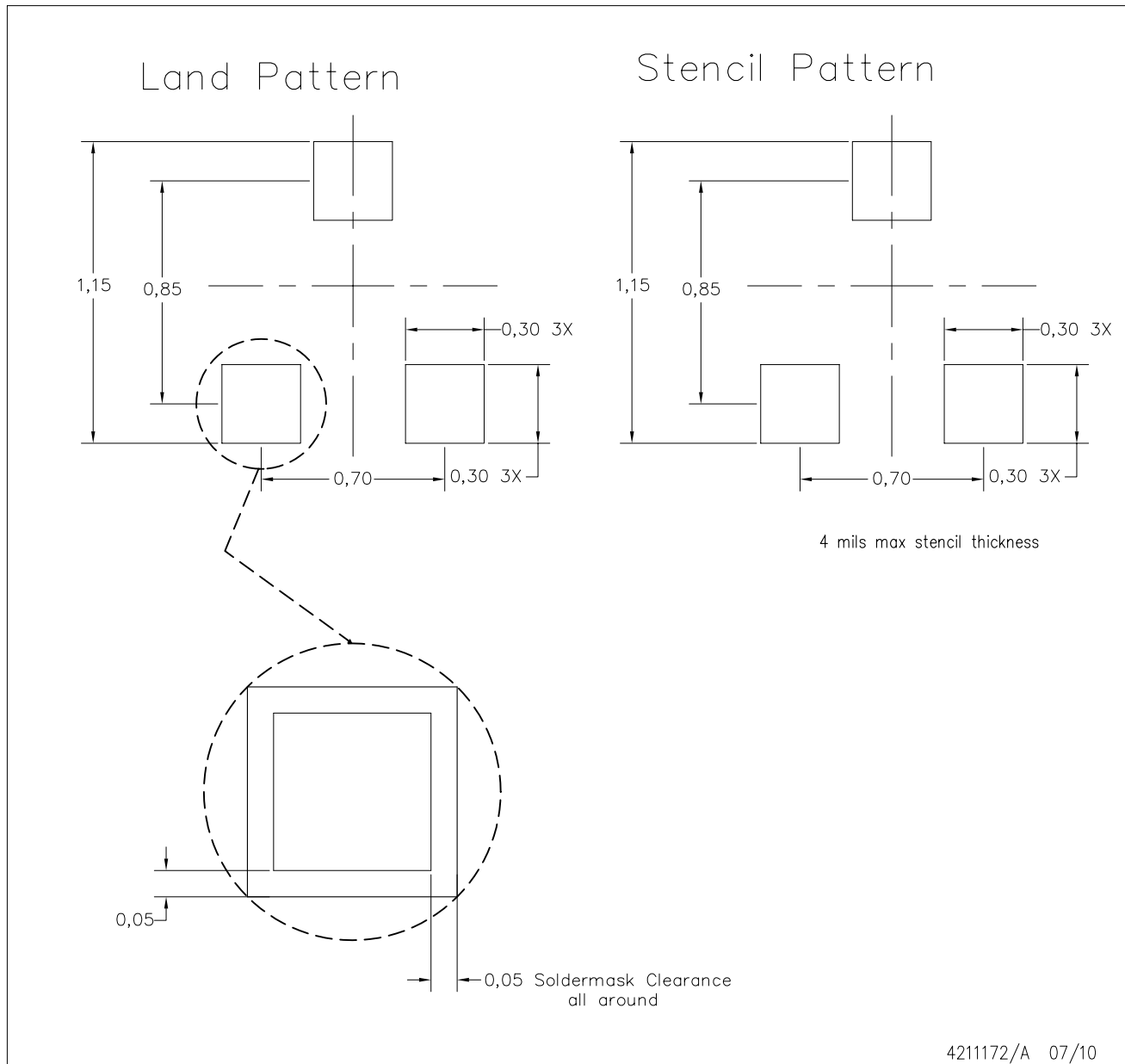

- NOTES:
- A. All linear dimensions are in millimeters.
  - B. This drawing is subject to change without notice.
  - C. Publication IPC-7351 is recommended for alternate designs.
  - D. Customers should contact their board fabrication site for minimum solder mask web tolerances between signal pads.
  - E. Maximum stencil thickness 0,1016 mm (4 mils). All linear dimensions are in millimeters.
  - F. Laser cutting apertures with trapezoidal walls and also rounding corners will offer better paste release. Customers should contact their board assembly site for stencil design recommendations. Refer to IPC 7525 for stencil design considerations.
  - G. Side aperture dimensions over-print land for acceptable area ratio > 0.66. Customer may reduce side aperture dimensions if stencil manufacturing process allows for sufficient release at smaller opening.

## 重要なお知らせと免責事項

TI は、技術データと信頼性データ(データシートを含みます)、設計リソース(リファレンス デザインを含みます)、アプリケーションや設計に関する各種アドバイス、Web ツール、安全性情報、その他のリソースを、欠陥が存在する可能性のある「現状のまま」提供しており、商品性および特定目的に対する適合性の黙示保証、第三者の知的財産権の非侵害保証を含むいかなる保証も、明示的または黙示的にかかわらず拒否します。

これらのリソースは、TI 製品を使用する設計の経験を積んだ開発者への提供を意図したものです。(1) お客様のアプリケーションに適した TI 製品の選定、(2) お客様のアプリケーションの設計、検証、試験、(3) お客様のアプリケーションに該当する各種規格や、その他のあらゆる安全性、セキュリティ、規制、または他の要件への確実な適合に関する責任を、お客様のみが単独で負うものとし、

上記の各種リソースは、予告なく変更される可能性があります。これらのリソースは、リソースで説明されている TI 製品を使用するアプリケーションの開発の目的でのみ、TI はその使用をお客様に許諾します。これらのリソースに関して、他の目的で複製することや掲載することは禁止されています。TI や第三者の知的財産権のライセンスが付与されている訳ではありません。お客様は、これらのリソースを自身で使用した結果発生するあらゆる申し立て、損害、費用、損失、責任について、TI およびその代理人を完全に補償するものとし、TI は一切の責任を拒否します。

TI の製品は、[TI の販売条件](#)、[TI の総合的な品質ガイドライン](#)、[ti.com](#) または TI 製品などに関連して提供される他の適用条件に従い提供されます。TI がこれらのリソースを提供することは、適用される TI の保証または他の保証の放棄の拡大や変更を意味するものではありません。TI がカスタム、またはカスタマー仕様として明示的に指定していない限り、TI の製品は標準的なカタログに掲載される汎用機器です。

お客様がいかなる追加条項または代替条項を提案する場合も、TI はそれらに異議を唱え、拒否します。

Copyright © 2025, Texas Instruments Incorporated

最終更新日：2025 年 10 月