

# TMUX1204 5V、4:1、汎用アナログ・マルチプレクサ

## 1 特長

- レール・ツー・レールの動作
- 双方向の信号パス
- 1.8V ロジック互換
- フェイルセーフ・ロジック
- 低いオン抵抗: 5Ω
- 広い電源電圧範囲: 1.08V~5.5V
- -40°C~+125°C の動作温度範囲
- 低い消費電流: 10nA
- 遷移時間: 14ns
- Break-Before-Make のスイッチング動作
- ESD 保護 (HBM): 2000V

## 2 アプリケーション

- アナログおよびデジタルの多重化/多重分離
- モータ・ドライブ
- サーボ・ドライブ制御モジュール
- ビルディング・オートメーション
- バーコード・スキャナ
- アナログ入力モジュール
- パワー・デリバリ
- 煙感知器
- ビデオ監視
- 熱画像処理カメラ
- 電子 POS
- 家電製品
- コンシューマ・オーディオ

## 3 概要

TMUX1204 は現代的な CMOS (Complementary Metal-Oxide Semiconductor) アナログ・マルチプレクサ (MUX) で、4:1 シングル・エンド (1 チャネル) 構成です。TMUX1204 は単一電源 (1.08V~5.5V) で動作するため、個人用電子機器からビルディング・オートメーション・システムまで広範なアプリケーションで使用可能です。消費電流が 10nA と低いため、携帯型アプリケーションで使用できます。

すべてのロジック入力には**1.8Vロジック互換**のスレッショルドがあり、有効な電源電圧範囲で動作していれば、TTL とCMOSの両方のロジックと互換性が保証されます。**フェイルセーフ・ロジック**回路により、電源ピンよりも前に制御ピンに電圧が印加されるため、デバイスへの損傷の可能性が避けられます。

### 製品情報<sup>(1)</sup>

型番	パッケージ	本体サイズ(公称)
TMUX1204	VSSOP (10) (DGS)	3.00mm×3.00mm
	USON (10) (DQA)	2.50mm×1.00mm

(1) 提供されているすべてのパッケージについては、データシートの末尾にあるパッケージ・オプションについての付録を参照してください。

アプリケーションの例

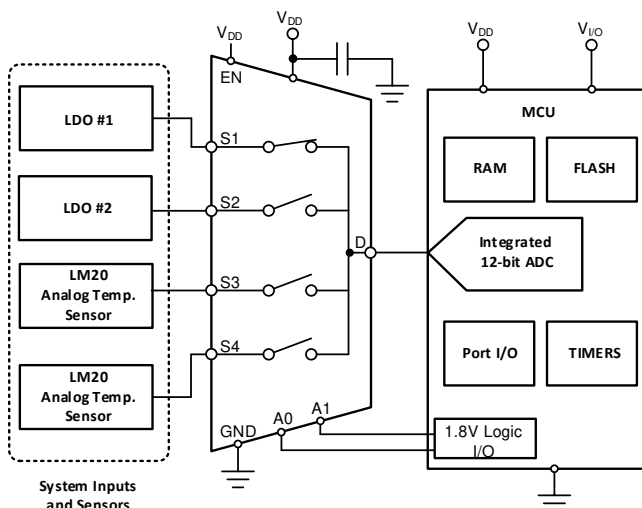

TMUX1204 ブロック図

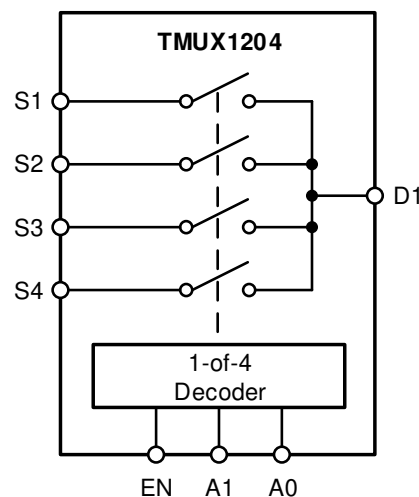

## 目次

1	特長 .....	1	7.10	Bandwidth .....	18
2	アプリケーション .....	1	8	<b>Detailed Description</b> .....	19
3	概要 .....	1	8.1	Functional Block Diagram .....	19
4	改訂履歴 .....	2	8.2	Feature Description .....	19
5	<b>Pin Configuration and Functions</b> .....	3	8.3	Device Functional Modes .....	20
6	<b>Specifications</b> .....	4	8.4	Truth Tables .....	20
6.1	Absolute Maximum Ratings .....	4	9	<b>Application and Implementation</b> .....	21
6.2	ESD Ratings .....	4	9.1	Application Information .....	21
6.3	Recommended Operating Conditions .....	4	9.2	Typical Application .....	21
6.4	Thermal Information .....	4	9.3	Design Requirements .....	21
6.5	Electrical Characteristics ( $V_{DD} = 5\text{ V} \pm 10\%$ ) .....	5	9.4	Detailed Design Procedure .....	22
6.6	Electrical Characteristics ( $V_{DD} = 3.3\text{ V} \pm 10\%$ ) .....	7	9.5	Application Curve .....	22
6.7	Electrical Characteristics ( $V_{DD} = 1.8\text{ V} \pm 10\%$ ) .....	9	10	<b>Power Supply Recommendations</b> .....	22
6.8	Electrical Characteristics ( $V_{DD} = 1.2\text{ V} \pm 10\%$ ) .....	11	11	<b>Layout</b> .....	23
6.9	Typical Characteristics .....	13	11.1	Layout Guidelines .....	23
7	<b>Parameter Measurement Information</b> .....	14	11.2	Layout Example .....	23
7.1	On-Resistance .....	14	12	デバイスおよびドキュメントのサポート .....	24
7.2	Off-Leakage Current .....	14	12.1	ドキュメントのサポート .....	24
7.3	On-Leakage Current .....	15	12.2	ドキュメントの更新通知を受け取る方法 .....	24
7.4	Transition Time .....	15	12.3	コミュニティ・リソース .....	24
7.5	Break-Before-Make .....	16	12.4	商標 .....	24
7.6	$t_{ON(EN)}$ and $t_{OFF(EN)}$ .....	16	12.5	静電気放電に関する注意事項 .....	24
7.7	Charge Injection .....	17	12.6	Glossary .....	24
7.8	Off Isolation .....	17	13	メカニカル、パッケージ、および注文情報 .....	24
7.9	Crosstalk .....	18			

## 4 改訂履歴

資料番号末尾の英字は改訂を表しています。その改訂履歴は英語版に準じています。

### 2019年4月発行のものから更新

	Page
• 「製品情報」表の DQA パッケージから製品プレビューを削除 .....	1
• Deleted Product preview from the DQA package in the <i>Pin Configuration and Functions</i> section .....	3
• Added Note 2 to the <i>Pin Functions</i> table .....	3

## 5 Pin Configuration and Functions

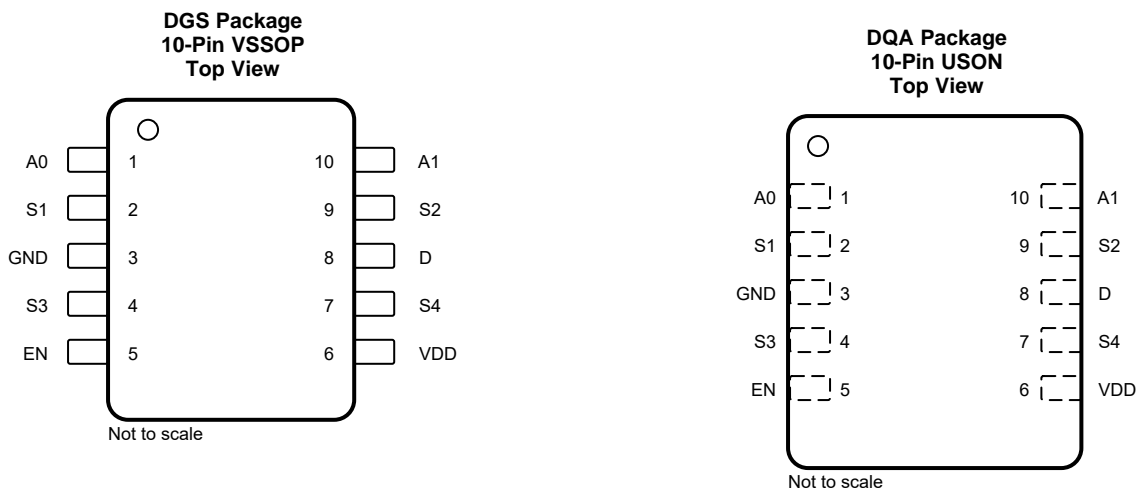

### Pin Functions

PIN		TYPE <sup>(1)</sup>	DESCRIPTION <sup>(2)</sup>
NAME	DGS, DQA		
A0	1	I	Address line 0. Controls the switch configuration as shown in <a href="#">表 1</a> .
S1	2	I/O	Source pin 1. Can be an input or output.
GND	3	P	Ground (0 V) reference
S3	4	I/O	Source pin 3. Can be an input or output.
EN	5	I	Active high logic enable. When this pin is low, all switches are turned off. When this pin is high, the A[1:0] logic inputs determine which switch is turned on.
VDD	6	P	Positive power supply. This pin is the most positive power-supply potential. For reliable operation, connect a decoupling capacitor ranging from 0.1 $\mu$ F to 10 $\mu$ F between V <sub>DD</sub> and GND.
S4	7	I/O	Source pin 4. Can be an input or output.
D	8	I/O	Drain pin. Can be an input or output.
S2	9	I/O	Source pin 2. Can be an input or output.
A1	10	I	Address line 1. Controls the switch configuration as shown in <a href="#">表 1</a> .

(1) I = input, O = output, I/O = input and output, P = power

(2) For unused pins, refer to the [Device Functional Modes](#)

## 6 Specifications

### 6.1 Absolute Maximum Ratings

over operating free-air temperature range (unless otherwise noted) <sup>(1)</sup> <sup>(2)</sup> <sup>(3)</sup>

		MIN	MAX	UNIT
$V_{DD}$	Supply voltage	-0.5	6	V
$V_{SEL}$ or $V_{EN}$	Logic control input pin voltage (EN, A0, A1)	-0.5	6	V
$I_{SEL}$ or $I_{EN}$	Logic control input pin current (EN, A0, A1)	-30	30	mA
$V_S$ or $V_D$	Source or drain voltage (Sx, D)	-0.5	$V_{DD}+0.5$	V
$I_S$ or $I_D$ (CONT)	Source or drain continuous current (Sx, D)	-30	30	mA
$T_{stg}$	Storage temperature	-65	150	°C
$T_J$	Junction temperature		150	°C

- (1) Stresses beyond those listed under *Absolute Maximum Rating* may cause permanent damage to the device. These are stress ratings only, which do not imply functional operation of the device at these or any other conditions beyond those indicated under *Recommended Operating Condition*. Exposure to absolute-maximum-rated conditions for extended periods may affect device reliability.
- (2) The algebraic convention, whereby the most negative value is a minimum and the most positive value is a maximum.
- (3) All voltages are with respect to ground, unless otherwise specified.

### 6.2 ESD Ratings

			VALUE	UNIT
$V_{(ESD)}$	Electrostatic discharge	Human body model (HBM), per ANSI/ESDA/JEDEC JS-001, all pins <sup>(1)</sup>	±2000	V
		Charged device model (CDM), per JEDEC specification JESD22-C101 or ANSI/ESDA/JEDEC JS-002, all pins <sup>(2)</sup>	±750	

- (1) JEDEC document JEP155 states that 500-V HBM allows safe manufacturing with a standard ESD control process.
- (2) JEDEC document JEP157 states that 250-V CDM allows safe manufacturing with a standard ESD control process.

### 6.3 Recommended Operating Conditions

over operating free-air temperature range (unless otherwise noted)

		MIN	NOM	MAX	UNIT
$V_{DD}$	Positive power supply voltage	1.08		5.5	V
$V_S$ or $V_D$	Signal path input/output voltage (source or drain pin) (Sx, D)	0		$V_{DD}$	V
$V_{SEL}$ or $V_{EN}$	Logic control input pin voltage (EN, A0, A1)	0		5.5	V
$T_A$	Ambient temperature	-40		125	°C

### 6.4 Thermal Information

THERMAL METRIC <sup>(1)</sup>		TMUX1204		UNIT
		DGS (VSSOP)	DQA (USON)	
		10 PINS	10 PINS	
$R_{\theta JA}$	Junction-to-ambient thermal resistance	193.9	173.0	°C/W
$R_{\theta JC(top)}$	Junction-to-case (top) thermal resistance	83.1	99.7	°C/W
$R_{\theta JB}$	Junction-to-board thermal resistance	116.5	73.5	°C/W
$\Psi_{JT}$	Junction-to-top characterization parameter	22.0	8.9	°C/W
$\Psi_{JB}$	Junction-to-board characterization parameter	114.6	73.0	°C/W
$R_{\theta JC(bot)}$	Junction-to-case (bottom) thermal resistance	N/A	N/A	°C/W

- (1) For more information about traditional and new thermal metrics, see the [Semiconductor and IC Package Thermal Metrics](#) application report.

## 6.5 Electrical Characteristics ( $V_{DD} = 5\text{ V} \pm 10\%$ )

at  $T_A = 25^\circ\text{C}$ ,  $V_{DD} = 5\text{ V}$  (unless otherwise noted)

PARAMETER		TEST CONDITIONS	TA	MIN	TYP	MAX	UNIT
<b>ANALOG SWITCH</b>							
$R_{ON}$	On-resistance	$V_S = 0\text{ V to }V_{DD}$ $I_{SD} = 10\text{ mA}$ Refer to <a href="#">On-Resistance</a>	25°C	5			$\Omega$
			–40°C to +85°C			7	$\Omega$
			–40°C to +125°C			9	$\Omega$
$\Delta R_{ON}$	On-resistance matching between channels	$V_S = 0\text{ V to }V_{DD}$ $I_{SD} = 10\text{ mA}$ Refer to <a href="#">On-Resistance</a>	25°C	0.15			$\Omega$
			–40°C to +85°C			1	$\Omega$
			–40°C to +125°C			1	$\Omega$
$R_{ON\text{ FLAT}}$	On-resistance flatness	$V_S = 0\text{ V to }V_{DD}$ $I_{SD} = 10\text{ mA}$ Refer to <a href="#">On-Resistance</a>	25°C	1.5			$\Omega$
			–40°C to +85°C			2	$\Omega$
			–40°C to +125°C			3	$\Omega$
$I_{S(OFF)}$	Source off leakage current <sup>(1)</sup>	$V_{DD} = 5\text{ V}$ Switch Off $V_D = 4.5\text{ V} / 1.5\text{ V}$ $V_S = 1.5\text{ V} / 4.5\text{ V}$ Refer to <a href="#">Off-Leakage Current</a>	25°C	$\pm 75$			nA
			–40°C to +85°C	–150		150	nA
			–40°C to +125°C	–175		175	nA
$I_{D(OFF)}$	Drain off leakage current <sup>(1)</sup>	$V_{DD} = 5\text{ V}$ Switch Off $V_D = 4.5\text{ V} / 1.5\text{ V}$ $V_S = 1.5\text{ V} / 4.5\text{ V}$ Refer to <a href="#">Off-Leakage Current</a>	25°C	$\pm 200$			nA
			–40°C to +85°C	–500		500	nA
			–40°C to +125°C	–750		750	nA
$I_{D(ON)}$ $I_{S(ON)}$	Channel on leakage current	$V_{DD} = 5\text{ V}$ Switch On $V_D = V_S = 4.5\text{ V} / 1.5\text{ V}$ Refer to <a href="#">On-Leakage Current</a>	25°C	$\pm 200$			nA
			–40°C to +85°C	–500		500	nA
			–40°C to +125°C	–750		750	nA
<b>LOGIC INPUTS (EN, A0, A1)</b>							
$V_{IH}$	Input logic high		–40°C to +125°C	1.49		5.5	V
$V_{IL}$	Input logic low		–40°C to +125°C	0		0.87	V
$I_{IH}$ $I_{IL}$	Input leakage current		25°C	$\pm 0.005$			$\mu\text{A}$
$I_{IH}$ $I_{IL}$	Input leakage current		–40°C to +125°C			$\pm 0.10$	$\mu\text{A}$
$C_{IN}$	Logic input capacitance		25°C	1			pF
$C_{IN}$	Logic input capacitance		–40°C to +125°C			2	pF
<b>POWER SUPPLY</b>							
$I_{DD}$	$V_{DD}$ supply current	Logic inputs = 0 V or 5.5 V	25°C	0.01			$\mu\text{A}$
			–40°C to +125°C			2	$\mu\text{A}$

(1) When  $V_S$  is 4.5 V,  $V_D$  is 1.5 V or when  $V_S$  is 1.5 V,  $V_D$  is 4.5 V.

**Electrical Characteristics ( $V_{DD} = 5\text{ V} \pm 10\%$ ) (continued)**

 at  $T_A = 25^\circ\text{C}$ ,  $V_{DD} = 5\text{ V}$  (unless otherwise noted)

PARAMETER		TEST CONDITIONS	TA	MIN	TYP	MAX	UNIT
<b>DYNAMIC CHARACTERISTICS</b>							
$t_{\text{TRAN}}$	Transition time between channels	$V_S = 3\text{ V}$ $R_L = 200\ \Omega$ , $C_L = 15\text{ pF}$ Refer to <a href="#">Transition Time</a>	25°C	14			ns
			–40°C to +85°C			21	ns
			–40°C to +125°C			22	ns
$t_{\text{OPEN}}$ (BBM)	Break before make time	$V_S = 3\text{ V}$ $R_L = 200\ \Omega$ , $C_L = 15\text{ pF}$ Refer to <a href="#">Break-Before-Make</a>	25°C	8			ns
			–40°C to +85°C	1			ns
			–40°C to +125°C	1			ns
$t_{\text{ON(EN)}}$	Enable turn-on time	$V_S = 3\text{ V}$ $R_L = 200\ \Omega$ , $C_L = 15\text{ pF}$ Refer to $t_{\text{ON(EN)}}$ and $t_{\text{OFF(EN)}}$	25°C	14			ns
			–40°C to +85°C			20	ns
			–40°C to +125°C			20	ns
$t_{\text{OFF(EN)}}$	Enable turn-off time	$V_S = 3\text{ V}$ $R_L = 200\ \Omega$ , $C_L = 15\text{ pF}$ Refer to $t_{\text{ON(EN)}}$ and $t_{\text{OFF(EN)}}$	25°C	5			ns
			–40°C to +85°C			20	ns
			–40°C to +125°C			20	ns
$Q_C$	Charge Injection	$V_S = 1\text{ V}$ $R_S = 0\ \Omega$ , $C_L = 1\text{ nF}$ Refer to <a href="#">Charge Injection</a>	25°C		±9		pC
$O_{\text{ISO}}$	Off Isolation	$R_L = 50\ \Omega$ , $C_L = 5\text{ pF}$ $f = 1\text{ MHz}$ Refer to <a href="#">Off Isolation</a>	25°C		–62		dB
		$R_L = 50\ \Omega$ , $C_L = 5\text{ pF}$ $f = 10\text{ MHz}$ Refer to <a href="#">Off Isolation</a>	25°C		–42		dB
$X_{\text{TALK}}$	Crosstalk	$R_L = 50\ \Omega$ , $C_L = 5\text{ pF}$ $f = 1\text{ MHz}$ Refer to <a href="#">Crosstalk</a>	25°C		–62		dB
		$R_L = 50\ \Omega$ , $C_L = 5\text{ pF}$ $f = 10\text{ MHz}$ Refer to <a href="#">Crosstalk</a>	25°C		–42		dB
BW	Bandwidth	$R_L = 50\ \Omega$ , $C_L = 5\text{ pF}$ Refer to <a href="#">Bandwidth</a>	25°C		125		MHz
$C_{\text{SOFF}}$	Source off capacitance	$f = 1\text{ MHz}$	25°C		13		pF
$C_{\text{DOFF}}$	Drain off capacitance	$f = 1\text{ MHz}$	25°C		38		pF
$C_{\text{SON}}$ $C_{\text{DON}}$	On capacitance	$f = 1\text{ MHz}$	25°C		42		pF

## 6.6 Electrical Characteristics ( $V_{DD} = 3.3\text{ V} \pm 10\%$ )

at  $T_A = 25^\circ\text{C}$ ,  $V_{DD} = 3.3\text{ V}$  (unless otherwise noted)

PARAMETER		TEST CONDITIONS	TA	MIN	TYP	MAX	UNIT
<b>ANALOG SWITCH</b>							
$R_{ON}$	On-resistance	$V_S = 0\text{ V to }V_{DD}$ $I_{SD} = 10\text{ mA}$ Refer to <a href="#">On-Resistance</a>	25°C	9			$\Omega$
			–40°C to +85°C			15	$\Omega$
			–40°C to +125°C			17	$\Omega$
$\Delta R_{ON}$	On-resistance matching between channels	$V_S = 0\text{ V to }V_{DD}$ $I_{SD} = 10\text{ mA}$ Refer to <a href="#">On-Resistance</a>	25°C	0.15			$\Omega$
			–40°C to +85°C			1	$\Omega$
			–40°C to +125°C			1	$\Omega$
$R_{ON\text{ FLAT}}$	On-resistance flatness	$V_S = 0\text{ V to }V_{DD}$ $I_{SD} = 10\text{ mA}$ Refer to <a href="#">On-Resistance</a>	25°C	3			$\Omega$
			–40°C to +85°C			5	$\Omega$
			–40°C to +125°C			6	$\Omega$
$I_{S(OFF)}$	Source off leakage current <sup>(1)</sup>	$V_{DD} = 3.3\text{ V}$ Switch Off $V_D = 3\text{ V} / 1\text{ V}$ $V_S = 1\text{ V} / 3\text{ V}$ Refer to <a href="#">Off-Leakage Current</a>	25°C	$\pm 75$			nA
			–40°C to +85°C	–150		150	nA
			–40°C to +125°C	–175		175	nA
$I_{D(OFF)}$	Drain off leakage current <sup>(1)</sup>	$V_{DD} = 3.3\text{ V}$ Switch Off $V_D = 3\text{ V} / 1\text{ V}$ $V_S = 1\text{ V} / 3\text{ V}$ Refer to <a href="#">Off-Leakage Current</a>	25°C	$\pm 200$			nA
			–40°C to +85°C	–500		500	nA
			–40°C to +125°C	–750		750	nA
$I_{D(ON)}$ $I_{S(ON)}$	Channel on leakage current	$V_{DD} = 3.3\text{ V}$ Switch On $V_D = V_S = 3\text{ V} / 1\text{ V}$ Refer to <a href="#">On-Leakage Current</a>	25°C	$\pm 200$			nA
			–40°C to +85°C	–500		500	nA
			–40°C to +125°C	–750		750	nA
<b>LOGIC INPUTS (EN, A0, A1)</b>							
$V_{IH}$	Input logic high		–40°C to +125°C	1.35		5.5	V
$V_{IL}$	Input logic low		–40°C to +125°C	0		0.8	V
$I_{IH}$ $I_{IL}$	Input leakage current		25°C	$\pm 0.005$			$\mu\text{A}$
$I_{IH}$ $I_{IL}$	Input leakage current		–40°C to +125°C			$\pm 0.10$	$\mu\text{A}$
$C_{IN}$	Logic input capacitance		25°C	1			pF
$C_{IN}$	Logic input capacitance		–40°C to +125°C			2	pF
<b>POWER SUPPLY</b>							
$I_{DD}$	$V_{DD}$ supply current	Logic inputs = 0 V or 5.5 V	25°C	0.01			$\mu\text{A}$
			–40°C to +125°C			1.3	$\mu\text{A}$

(1) When  $V_S$  is 3 V,  $V_D$  is 1 V or when  $V_S$  is 1 V,  $V_D$  is 3 V.

**Electrical Characteristics ( $V_{DD} = 3.3\text{ V} \pm 10\%$ ) (continued)**

 at  $T_A = 25^\circ\text{C}$ ,  $V_{DD} = 3.3\text{ V}$  (unless otherwise noted)

PARAMETER		TEST CONDITIONS	TA	MIN	TYP	MAX	UNIT
<b>DYNAMIC CHARACTERISTICS</b>							
$t_{\text{TRAN}}$	Transition time between channels	$V_S = 2\text{ V}$ $R_L = 200\ \Omega$ , $C_L = 15\text{ pF}$ Refer to <a href="#">Transition Time</a>	25°C	14			ns
			–40°C to +85°C			25	ns
			–40°C to +125°C			25	ns
$t_{\text{OPEN}}$ (BBM)	Break before make time	$V_S = 2\text{ V}$ $R_L = 200\ \Omega$ , $C_L = 15\text{ pF}$ Refer to <a href="#">Break-Before-Make</a>	25°C	8			ns
			–40°C to +85°C	1			ns
			–40°C to +125°C	1			ns
$t_{\text{ON(EN)}}$	Enable turn-on time	$V_S = 2\text{ V}$ $R_L = 200\ \Omega$ , $C_L = 15\text{ pF}$ Refer to $t_{\text{ON(EN)}}$ and $t_{\text{OFF(EN)}}$	25°C	14			ns
			–40°C to +85°C			25	ns
			–40°C to +125°C			25	ns
$t_{\text{OFF(EN)}}$	Enable turn-off time	$V_S = 2\text{ V}$ $R_L = 200\ \Omega$ , $C_L = 15\text{ pF}$ Refer to $t_{\text{ON(EN)}}$ and $t_{\text{OFF(EN)}}$	25°C	7			ns
			–40°C to +85°C			13	ns
			–40°C to +125°C			13	ns
$Q_C$	Charge Injection	$V_S = 1\text{ V}$ $R_S = 0\ \Omega$ , $C_L = 1\text{ nF}$ Refer to <a href="#">Charge Injection</a>	25°C		$\pm 7$		pC
$O_{\text{ISO}}$	Off Isolation	$R_L = 50\ \Omega$ , $C_L = 5\text{ pF}$ $f = 1\text{ MHz}$ Refer to <a href="#">Off Isolation</a>	25°C		–62		dB
		$R_L = 50\ \Omega$ , $C_L = 5\text{ pF}$ $f = 10\text{ MHz}$ Refer to <a href="#">Off Isolation</a>	25°C		–42		dB
$X_{\text{TALK}}$	Crosstalk	$R_L = 50\ \Omega$ , $C_L = 5\text{ pF}$ $f = 1\text{ MHz}$ Refer to <a href="#">Crosstalk</a>	25°C		–62		dB
		$R_L = 50\ \Omega$ , $C_L = 5\text{ pF}$ $f = 10\text{ MHz}$ Refer to <a href="#">Crosstalk</a>	25°C		–42		dB
BW	Bandwidth	$R_L = 50\ \Omega$ , $C_L = 5\text{ pF}$ Refer to <a href="#">Bandwidth</a>	25°C		125		MHz
$C_{\text{SOFF}}$	Source off capacitance	$f = 1\text{ MHz}$	25°C		13		pF
$C_{\text{DOFF}}$	Drain off capacitance	$f = 1\text{ MHz}$	25°C		38		pF
$C_{\text{SON}}$ $C_{\text{DON}}$	On capacitance	$f = 1\text{ MHz}$	25°C		42		pF



## 6.7 Electrical Characteristics ( $V_{DD} = 1.8\text{ V} \pm 10\%$ )

at  $T_A = 25^\circ\text{C}$ ,  $V_{DD} = 1.8\text{ V}$  (unless otherwise noted)

PARAMETER		TEST CONDITIONS	TA	MIN	TYP	MAX	UNIT
<b>ANALOG SWITCH</b>							
$R_{ON}$	On-resistance	$V_S = 0\text{ V to }V_{DD}$ $I_{SD} = 10\text{ mA}$ Refer to <a href="#">On-Resistance</a>	25°C	40			$\Omega$
			-40°C to +85°C			80	$\Omega$
			-40°C to +125°C			80	$\Omega$
$\Delta R_{ON}$	On-resistance matching between channels	$V_S = 0\text{ V to }V_{DD}$ $I_{SD} = 10\text{ mA}$ Refer to <a href="#">On-Resistance</a>	25°C	0.15			$\Omega$
			-40°C to +85°C			1.5	$\Omega$
			-40°C to +125°C			1.5	$\Omega$
$I_{S(OFF)}$	Source off leakage current <sup>(1)</sup>	$V_{DD} = 1.98\text{ V}$ Switch Off $V_D = 1.8\text{ V} / 1\text{ V}$ $V_S = 1\text{ V} / 1.8\text{ V}$ Refer to <a href="#">Off-Leakage Current</a>	25°C	$\pm 75$			nA
			-40°C to +85°C	-150		150	nA
			-40°C to +125°C	-175		175	nA
$I_{D(OFF)}$	Drain off leakage current <sup>(1)</sup>	$V_{DD} = 1.98\text{ V}$ Switch Off $V_D = 1.8\text{ V} / 1\text{ V}$ $V_S = 1\text{ V} / 1.8\text{ V}$ Refer to <a href="#">Off-Leakage Current</a>	25°C	$\pm 200$			nA
			-40°C to +85°C	-500		500	nA
			-40°C to +125°C	-750		750	nA
$I_{D(ON)}$ $I_{S(ON)}$	Channel on leakage current	$V_{DD} = 1.98\text{ V}$ Switch On $V_D = V_S = 1.8\text{ V} / 1\text{ V}$ Refer to <a href="#">On-Leakage Current</a>	25°C	$\pm 200$			nA
			-40°C to +85°C	-500		500	nA
			-40°C to +125°C	-750		750	nA
<b>LOGIC INPUTS (EN, A0, A1)</b>							
$V_{IH}$	Input logic high		-40°C to +125°C	1.07		5.5	V
$V_{IL}$	Input logic low		-40°C to +125°C	0		0.68	V
$I_{IH}$ $I_{IL}$	Input leakage current		25°C	$\pm 0.005$			$\mu\text{A}$
			-40°C to +125°C			$\pm 0.10$	$\mu\text{A}$
$C_{IN}$	Logic input capacitance		25°C	1			pF
$C_{IN}$	Logic input capacitance		-40°C to +125°C			2	pF
<b>POWER SUPPLY</b>							
$I_{DD}$	$V_{DD}$ supply current	Logic inputs = 0 V or 5.5 V	25°C	0.005			$\mu\text{A}$
			-40°C to +125°C			0.95	$\mu\text{A}$

(1) When  $V_S$  is 1.8 V,  $V_D$  is 1 V or when  $V_S$  is 1 V,  $V_D$  is 1.8 V.

**Electrical Characteristics ( $V_{DD} = 1.8\text{ V} \pm 10\%$ ) (continued)**

 at  $T_A = 25^\circ\text{C}$ ,  $V_{DD} = 1.8\text{ V}$  (unless otherwise noted)

PARAMETER		TEST CONDITIONS	TA	MIN	TYP	MAX	UNIT
<b>DYNAMIC CHARACTERISTICS</b>							
$t_{\text{TRAN}}$	Transition time between channels	$V_S = 1\text{ V}$ $R_L = 200\ \Omega$ , $C_L = 15\text{ pF}$ Refer to <a href="#">Transition Time</a>	25°C	28			ns
			–40°C to +85°C			48	ns
			–40°C to +125°C			48	ns
$t_{\text{OPEN}}$ (BBM)	Break before make time	$V_S = 1\text{ V}$ $R_L = 200\ \Omega$ , $C_L = 15\text{ pF}$ Refer to <a href="#">Break-Before-Make</a>	25°C	16			ns
			–40°C to +85°C	1			ns
			–40°C to +125°C	1			ns
$t_{\text{ON(EN)}}$	Enable turn-on time	$V_S = 1\text{ V}$ $R_L = 200\ \Omega$ , $C_L = 15\text{ pF}$ Refer to $t_{\text{ON(EN)}}$ and $t_{\text{OFF(EN)}}$	25°C	28			ns
			–40°C to +85°C			48	ns
			–40°C to +125°C			48	ns
$t_{\text{OFF(EN)}}$	Enable turn-off time	$V_S = 1\text{ V}$ $R_L = 200\ \Omega$ , $C_L = 15\text{ pF}$ Refer to $t_{\text{ON(EN)}}$ and $t_{\text{OFF(EN)}}$	25°C	16			ns
			–40°C to +85°C			27	ns
			–40°C to +125°C			27	ns
$Q_C$	Charge Injection	$V_S = 1\text{ V}$ $R_S = 0\ \Omega$ , $C_L = 1\text{ nF}$ Refer to <a href="#">Charge Injection</a>	25°C	–2			pC
$O_{\text{ISO}}$	Off Isolation	$R_L = 50\ \Omega$ , $C_L = 5\text{ pF}$ $f = 1\text{ MHz}$ Refer to <a href="#">Off Isolation</a>	25°C	–62			dB
		$R_L = 50\ \Omega$ , $C_L = 5\text{ pF}$ $f = 10\text{ MHz}$ Refer to <a href="#">Off Isolation</a>	25°C	–42			dB
$X_{\text{TALK}}$	Crosstalk	$R_L = 50\ \Omega$ , $C_L = 5\text{ pF}$ $f = 1\text{ MHz}$ Refer to <a href="#">Crosstalk</a>	25°C	–62			dB
		$R_L = 50\ \Omega$ , $C_L = 5\text{ pF}$ $f = 10\text{ MHz}$ Refer to <a href="#">Crosstalk</a>	25°C	–42			dB
BW	Bandwidth	$R_L = 50\ \Omega$ , $C_L = 5\text{ pF}$ Refer to <a href="#">Bandwidth</a>	25°C	125			MHz
$C_{\text{SOFF}}$	Source off capacitance	$f = 1\text{ MHz}$	25°C	13			pF
$C_{\text{DOFF}}$	Drain off capacitance	$f = 1\text{ MHz}$	25°C	38			pF
$C_{\text{SON}}$ $C_{\text{DON}}$	On capacitance	$f = 1\text{ MHz}$	25°C	42			pF

**6.8 Electrical Characteristics ( $V_{DD} = 1.2\text{ V} \pm 10\%$ )**

PARAMETER		TEST CONDITIONS	TA	MIN	TYP	MAX	UNIT
<b>ANALOG SWITCH</b>							
$R_{ON}$	On-resistance	$V_S = 0\text{ V to }V_{DD}$ $I_{SD} = 10\text{ mA}$ Refer to <a href="#">On-Resistance</a>	25°C	70			$\Omega$
			-40°C to +85°C			105	$\Omega$
			-40°C to +125°C			105	$\Omega$
$\Delta R_{ON}$	On-resistance matching between channels	$V_S = 0\text{ V to }V_{DD}$ $I_{SD} = 10\text{ mA}$ Refer to <a href="#">On-Resistance</a>	25°C	0.15			$\Omega$
			-40°C to +85°C			1.5	$\Omega$
			-40°C to +125°C			1.5	$\Omega$
$I_{S(OFF)}$	Source off leakage current <sup>(1)</sup>	$V_{DD} = 1.32\text{ V}$ Switch Off $V_D = 1.2\text{ V} / 1\text{ V}$ $V_S = 1\text{ V} / 1.2\text{ V}$ Refer to <a href="#">Off-Leakage Current</a>	25°C	$\pm 75$			nA
			-40°C to +85°C	-150		150	nA
			-40°C to +125°C	-175		175	nA
$I_{D(OFF)}$	Drain off leakage current <sup>(1)</sup>	$V_{DD} = 1.32\text{ V}$ Switch Off $V_D = 1.2\text{ V} / 1\text{ V}$ $V_S = 1\text{ V} / 1.2\text{ V}$ Refer to <a href="#">Off-Leakage Current</a>	25°C	$\pm 200$			nA
			-40°C to +85°C	-500		500	nA
			-40°C to +125°C	-750		750	nA
$I_{D(ON)}$ $I_{S(ON)}$	Channel on leakage current	$V_{DD} = 1.32\text{ V}$ Switch On $V_D = V_S = 1.2\text{ V} / 1\text{ V}$ Refer to <a href="#">On-Leakage Current</a>	25°C	$\pm 200$			nA
			-40°C to +85°C	-500		500	nA
			-40°C to +125°C	-750		750	nA
<b>LOGIC INPUTS (EN, A0, A1)</b>							
$V_{IH}$	Input logic high		-40°C to +125°C	0.96		5.5	V
$V_{IL}$	Input logic low		-40°C to +125°C	0		0.36	V
$I_{IH}$ $I_{IL}$	Input leakage current		25°C	$\pm 0.005$			$\mu\text{A}$
			-40°C to +125°C			$\pm 0.10$	$\mu\text{A}$
$C_{IN}$	Logic input capacitance		25°C	1			pF
$C_{IN}$	Logic input capacitance		-40°C to +125°C			2	pF
<b>POWER SUPPLY</b>							
$I_{DD}$	$V_{DD}$ supply current	Logic inputs = 0 V or 5.5 V	25°C	0.005			$\mu\text{A}$
			-40°C to +125°C			0.8	$\mu\text{A}$

(1) When  $V_S$  is 1 V,  $V_D$  is 1.2 V or when  $V_S$  is 1.2 V,  $V_D$  is 1 V.

**Electrical Characteristics ( $V_{DD} = 1.2\text{ V} \pm 10\%$ ) (continued)**

PARAMETER		TEST CONDITIONS	TA	MIN	TYP	MAX	UNIT
<b>DYNAMIC CHARACTERISTICS</b>							
$t_{\text{TRAN}}$	Transition time between channels	$V_S = 1\text{ V}$ $R_L = 200\ \Omega$ , $C_L = 15\text{ pF}$ Refer to <a href="#">Transition Time</a>	25°C	60			ns
			–40°C to +85°C			210	ns
			–40°C to +125°C			210	ns
$t_{\text{OPEN}}$ (BBM)	Break before make time	$V_S = 1\text{ V}$ $R_L = 200\ \Omega$ , $C_L = 15\text{ pF}$ Refer to <a href="#">Break-Before-Make</a>	25°C	28			ns
			–40°C to +85°C	1			ns
			–40°C to +125°C	1			ns
$t_{\text{ON(EN)}}$	Enable turn-on time	$V_S = 1\text{ V}$ $R_L = 200\ \Omega$ , $C_L = 15\text{ pF}$ Refer to $t_{\text{ON(EN)}}$ and $t_{\text{OFF(EN)}}$	25°C	60			ns
			–40°C to +85°C			190	ns
			–40°C to +125°C			190	ns
$t_{\text{OFF(EN)}}$	Enable turn-off time	$V_S = 1\text{ V}$ $R_L = 200\ \Omega$ , $C_L = 15\text{ pF}$ Refer to $t_{\text{ON(EN)}}$ and $t_{\text{OFF(EN)}}$	25°C	45			ns
			–40°C to +85°C			150	ns
			–40°C to +125°C			150	ns
$Q_C$	Charge Injection	$V_S = 1\text{ V}$ $R_S = 0\ \Omega$ , $C_L = 1\text{ nF}$ Refer to <a href="#">Charge Injection</a>	25°C	$\pm 2$			pC
$O_{\text{ISO}}$	Off Isolation	$R_L = 50\ \Omega$ , $C_L = 5\text{ pF}$ $f = 1\text{ MHz}$ Refer to <a href="#">Off Isolation</a>	25°C	–62			dB
		$R_L = 50\ \Omega$ , $C_L = 5\text{ pF}$ $f = 10\text{ MHz}$ Refer to <a href="#">Off Isolation</a>	25°C	–42			dB
$X_{\text{TALK}}$	Crosstalk	$R_L = 50\ \Omega$ , $C_L = 5\text{ pF}$ $f = 1\text{ MHz}$ Refer to <a href="#">Crosstalk</a>	25°C	–62			dB
		$R_L = 50\ \Omega$ , $C_L = 5\text{ pF}$ $f = 10\text{ MHz}$ Refer to <a href="#">Crosstalk</a>	25°C	–42			dB
BW	Bandwidth	$R_L = 50\ \Omega$ , $C_L = 5\text{ pF}$ Refer to <a href="#">Bandwidth</a>	25°C	125			MHz
$C_{\text{SOFF}}$	Source off capacitance	$f = 1\text{ MHz}$	25°C	13			pF
$C_{\text{DOFF}}$	Drain off capacitance	$f = 1\text{ MHz}$	25°C	38			pF
$C_{\text{SON}}$ $C_{\text{DON}}$	On capacitance	$f = 1\text{ MHz}$	25°C	42			pF

### 6.9 Typical Characteristics

at  $T_A = 25^\circ\text{C}$ ,  $V_{DD} = 5\text{ V}$  (unless otherwise noted)



图 1. On-Resistance vs Source or Drain Voltage



图 2. On-Resistance vs Source or Drain Voltage

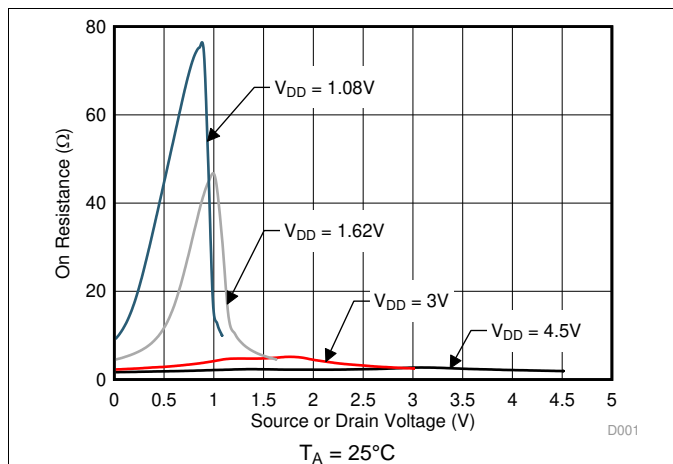

图 3.  $T_{ON}$  (EN) and  $T_{OFF}$  (EN) vs Supply Voltage

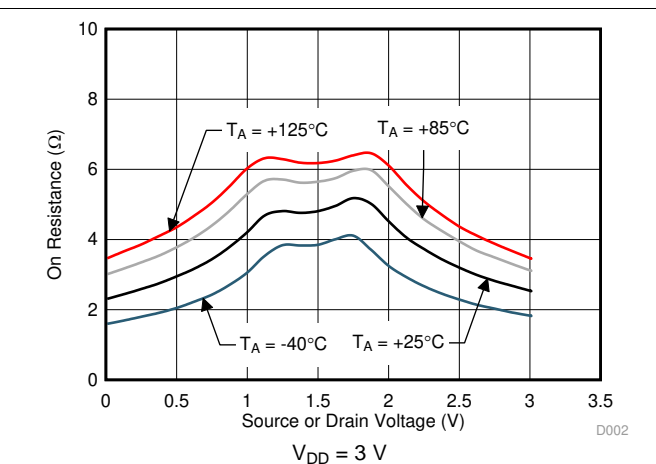

图 4.  $T_{ON}$  (EN) and  $T_{OFF}$  (EN) vs Temperature

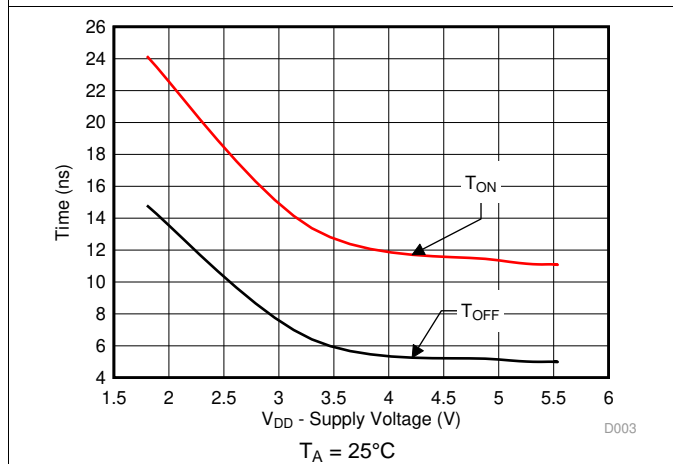

图 5. Supply Current vs Logic Voltage

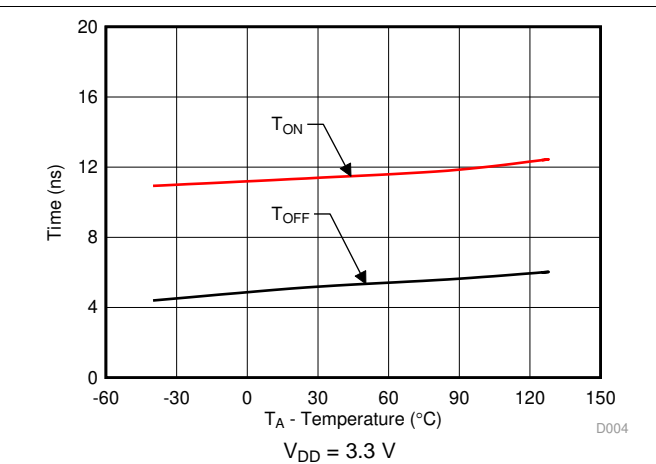

图 6. Frequency Response

## 7 Parameter Measurement Information

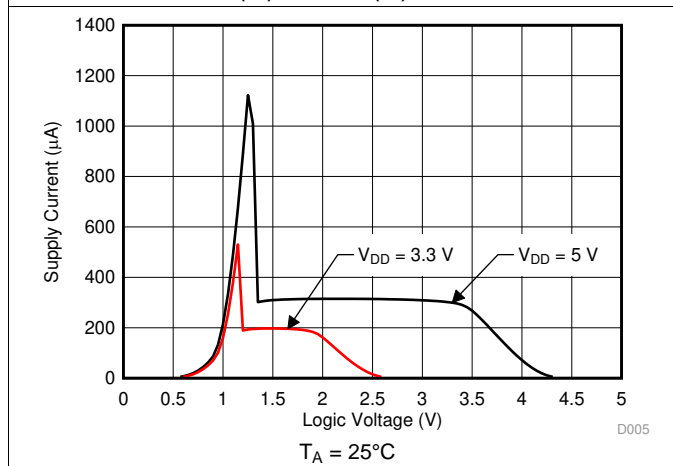
### 7.1 On-Resistance

The on-resistance of a device is the ohmic resistance between the source (Sx) and drain (D) pins of the device. The on-resistance varies with input voltage and supply voltage. The symbol  $R_{ON}$  is used to denote on-resistance. The measurement setup used to measure  $R_{ON}$  is shown in [Figure 7](#). Voltage (V) and current ( $I_{SD}$ ) are measured using this setup, and  $R_{ON}$  is computed with  $R_{ON} = V / I_{SD}$ :

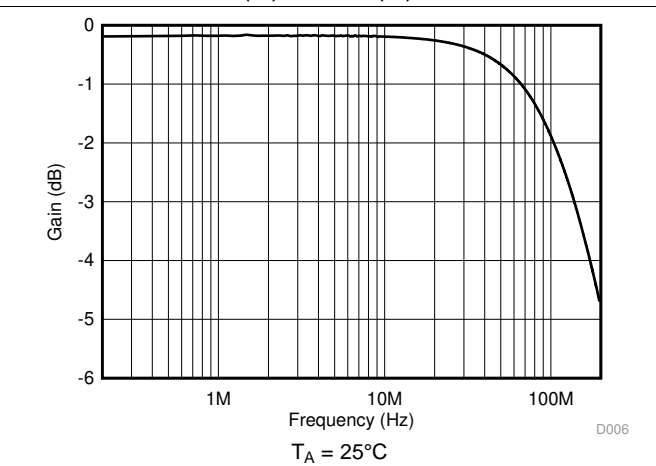
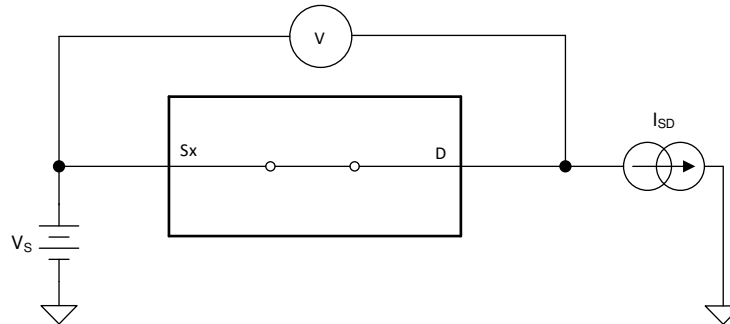

**Figure 7. On-Resistance Measurement Setup**

### 7.2 Off-Leakage Current

There are two types of leakage currents associated with a switch during the off state:

1. Source off-leakage current
2. Drain off-leakage current

Source leakage current is defined as the leakage current flowing into or out of the source pin when the switch is off. This current is denoted by the symbol  $I_{S(OFF)}$ .

Drain leakage current is defined as the leakage current flowing into or out of the drain pin when the switch is off. This current is denoted by the symbol  $I_{D(OFF)}$ .

The setup used to measure both off-leakage currents is shown in [Figure 8](#).

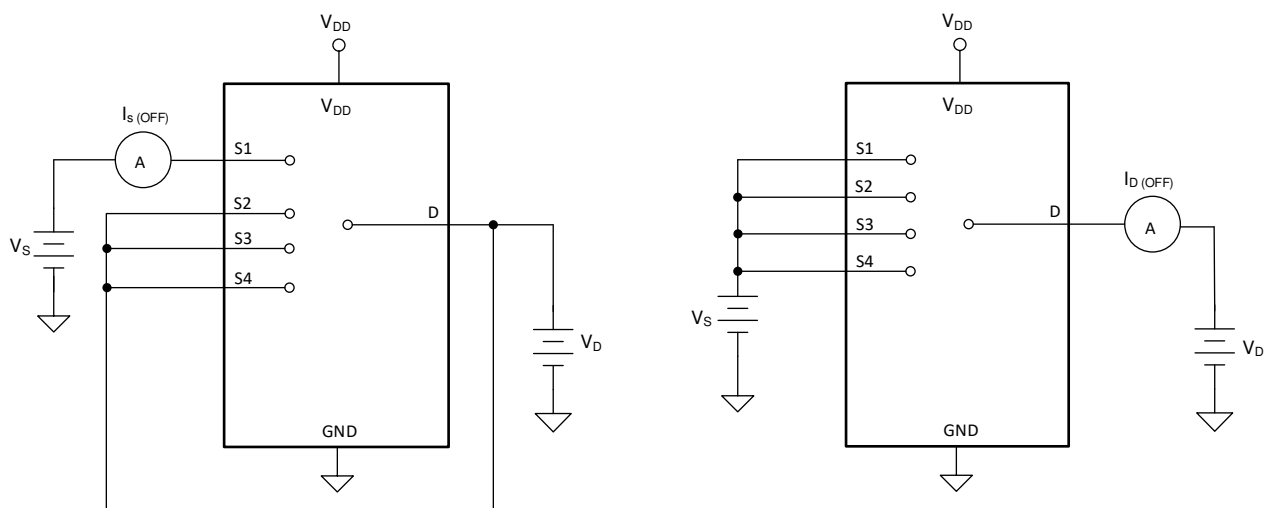

**Figure 8. Off-Leakage Measurement Setup**

### 7.3 On-Leakage Current

Source on-leakage current is defined as the leakage current flowing into or out of the source pin when the switch is on. This current is denoted by the symbol  $I_{S(ON)}$ .

Drain on-leakage current is defined as the leakage current flowing into or out of the drain pin when the switch is on. This current is denoted by the symbol  $I_{D(ON)}$ .

Either the source pin or drain pin is left floating during the measurement. Figure 9 shows the circuit used for measuring the on-leakage current, denoted by  $I_{S(ON)}$  or  $I_{D(ON)}$ .

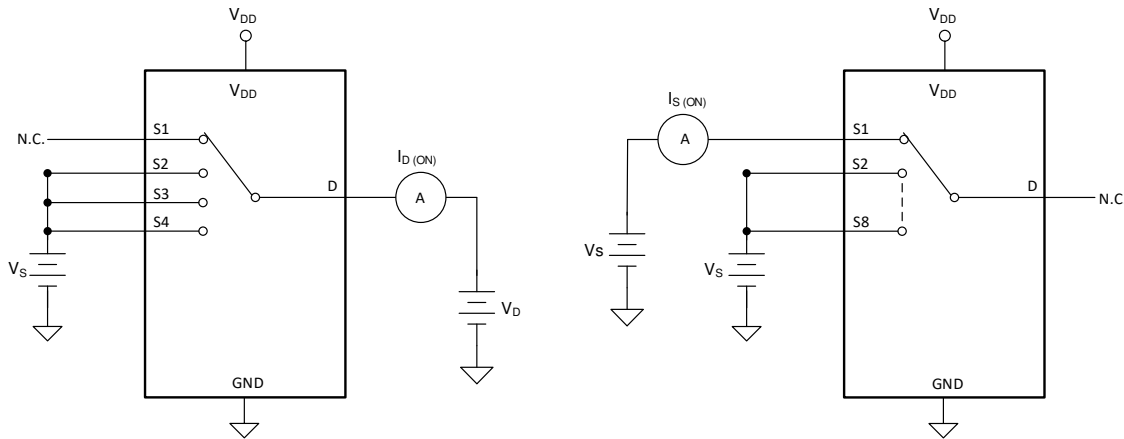

Figure 9. On-Leakage Measurement Setup

### 7.4 Transition Time

Transition time is defined as the time taken by the output of the device to rise or fall 10% after the address signal has risen or fallen past the logic threshold. The 10% transition measurement is utilized to provide the timing of the device. System level timing can then account for the time constant added from the load resistance and load capacitance. Figure 10 shows the setup used to measure transition time, denoted by the symbol  $t_{TRANSITION}$ .

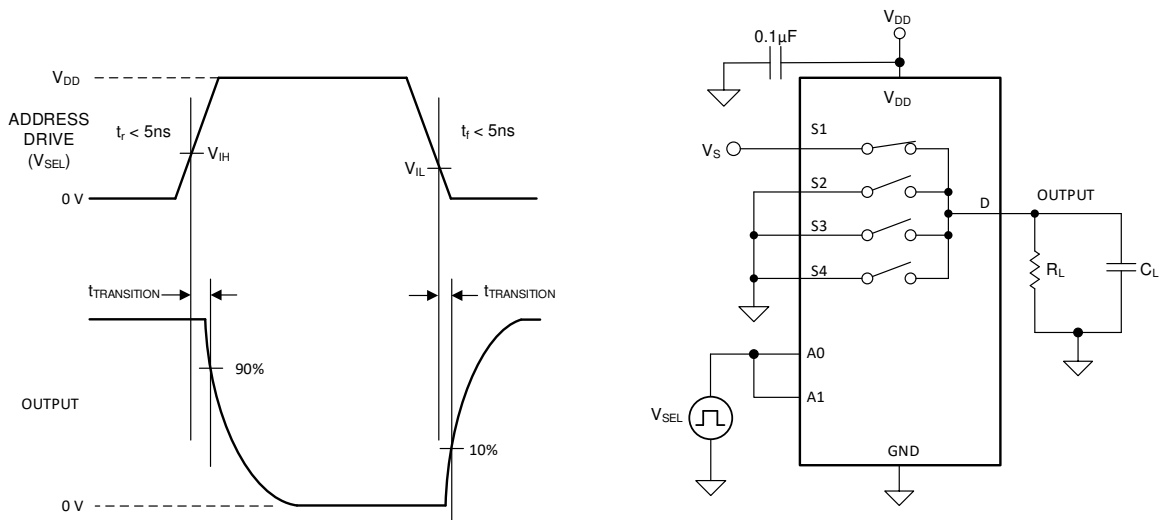
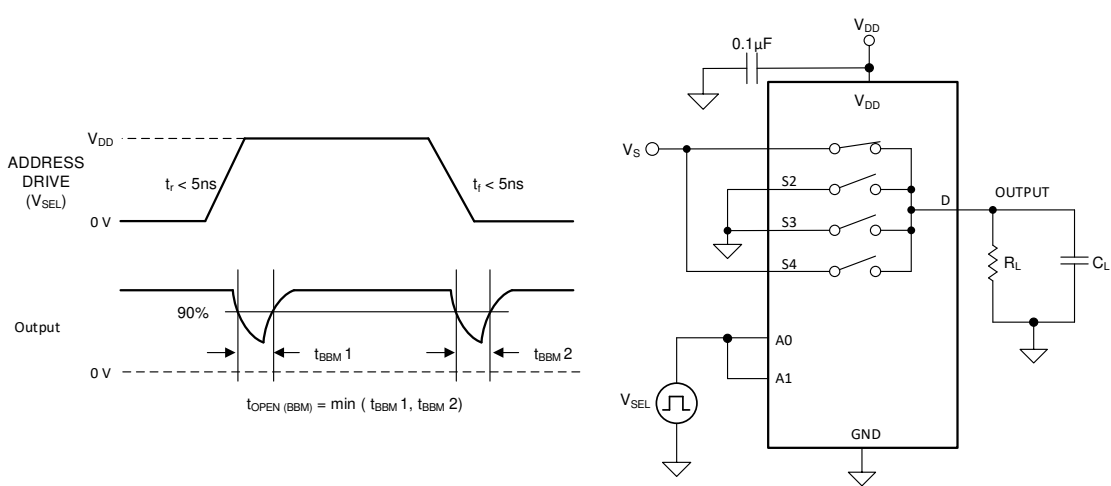
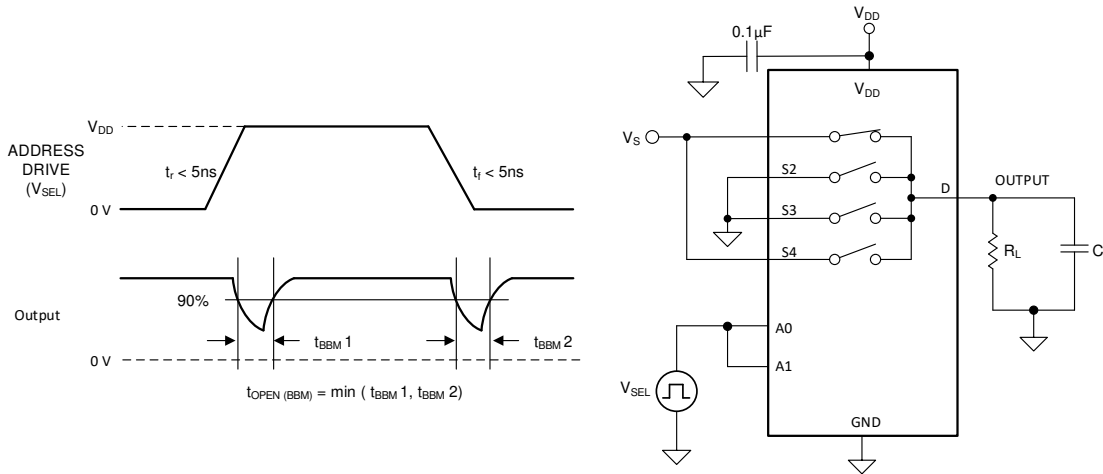

Figure 10. Transition-Time Measurement Setup

### 7.5 Break-Before-Make

Break-before-make delay is a safety feature that prevents two inputs from connecting when the device is switching. The output first breaks from the on-state switch before making the connection with the next on-state switch. The time delay between the *break* and the *make* is known as break-before-make delay.  shows the setup used to measure break-before-make delay, denoted by the symbol  $t_{OPEN(BBM)}$ .



 11. Break-Before-Make Delay Measurement Setup

### 7.6 $t_{ON(EN)}$ and $t_{OFF(EN)}$

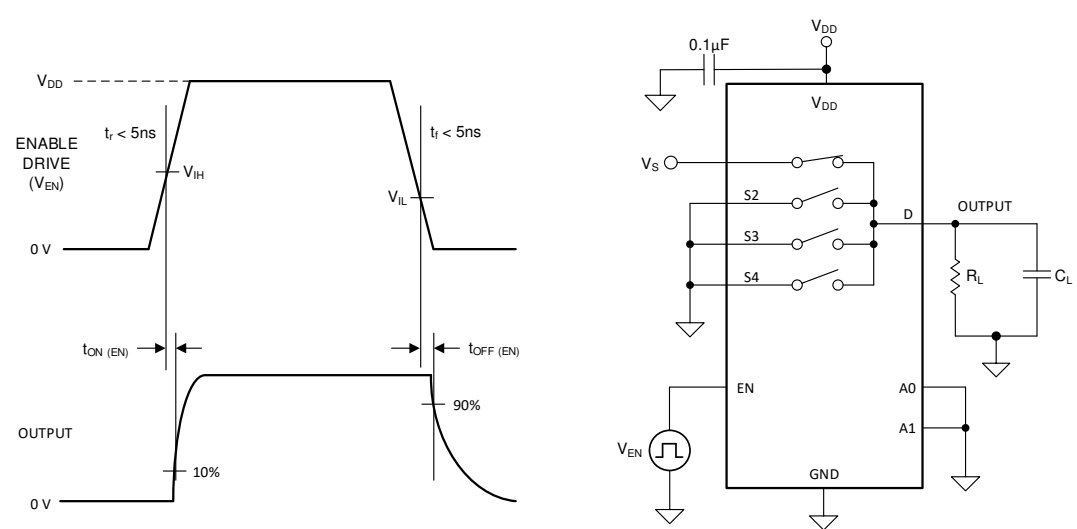
Turn-on time is defined as the time taken by the output of the device to rise to 10% after the enable has risen past the logic threshold. The 10% measurement is utilized to provide the timing of the device. System level timing can then account for the time constant added from the load resistance and load capacitance.  shows the setup used to measure turn-on time, denoted by the symbol  $t_{ON(EN)}$ .

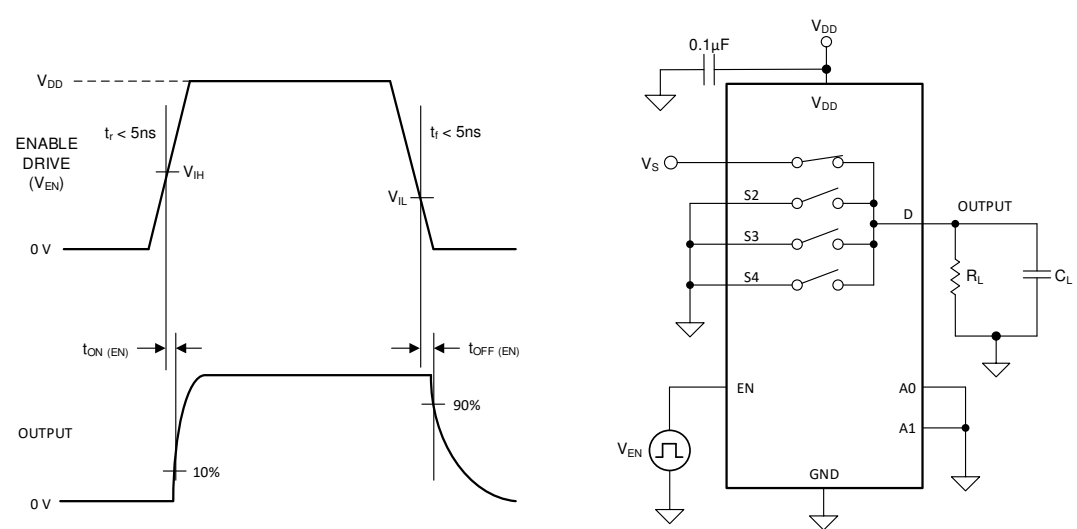
Turn-off time is defined as the time taken by the output of the device to fall to 90% after the enable has fallen past the logic threshold. The 90% measurement is utilized to provide the timing of the device. System level timing can then account for the time constant added from the load resistance and load capacitance.  shows the setup used to measure turn-off time, denoted by the symbol  $t_{OFF(EN)}$ .

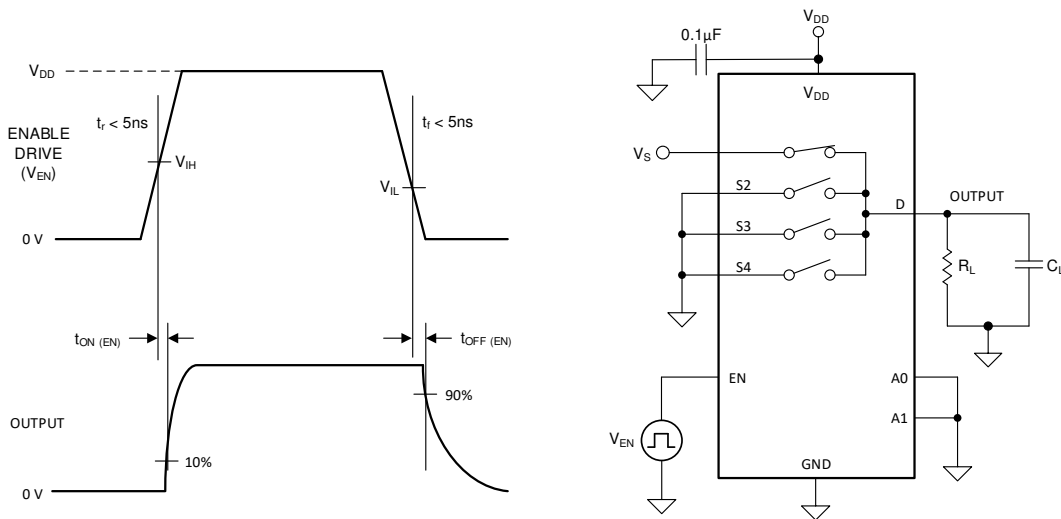

 12. Turn-On and Turn-Off Time Measurement Setup



### 7.7 Charge Injection

The TMUX1204 has a transmission-gate topology. Any mismatch in capacitance between the NMOS and PMOS transistors results in a charge injected into the drain or source during the falling or rising edge of the gate signal. The amount of charge injected into the source or drain of the device is known as charge injection, and is denoted by the symbol  $Q_C$ . Figure 13 shows the setup used to measure charge injection from source (Sx) to drain (D).

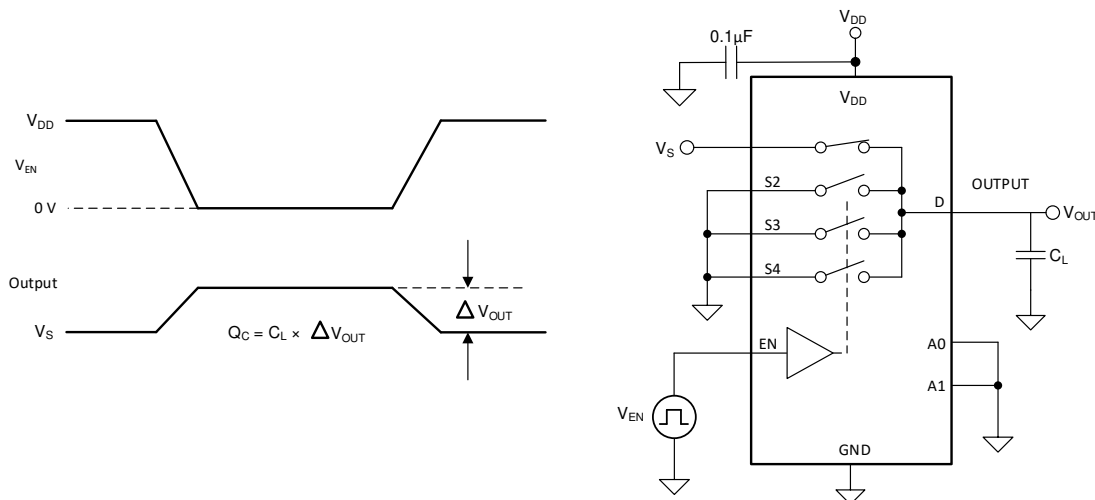

Figure 13. Charge-Injection Measurement Setup

### 7.8 Off Isolation

Off isolation is defined as the ratio of the signal at the drain pin (D) of the device when a signal is applied to the source pin (Sx) of an off-channel. Figure 14 shows the setup used to measure, and the equation used to calculate off isolation.

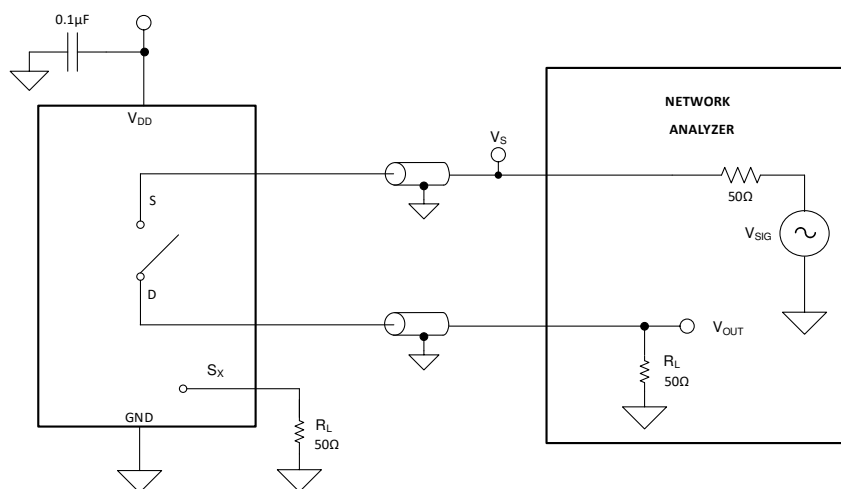
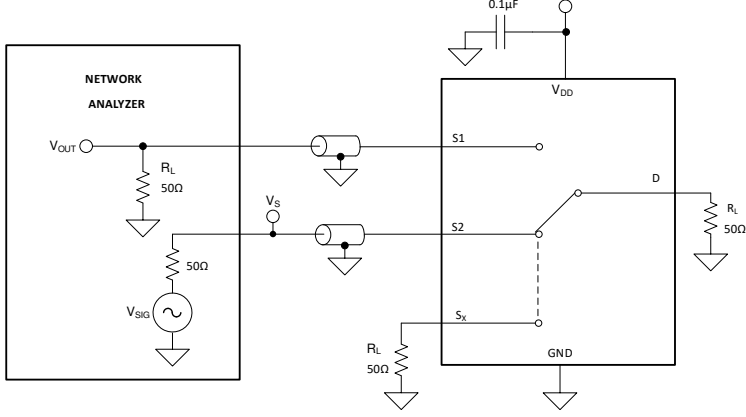
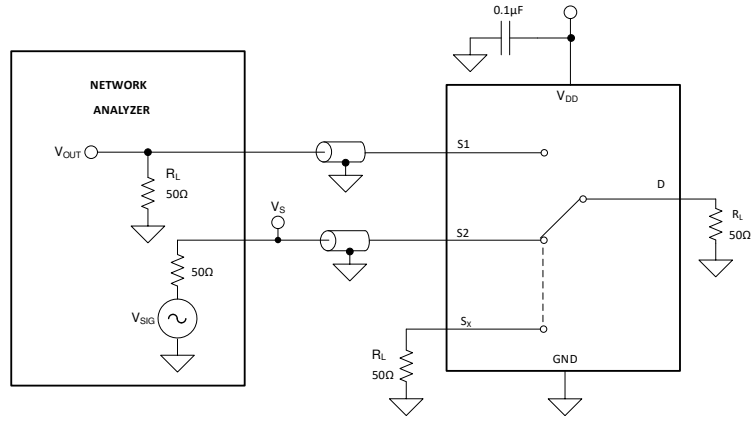

Figure 14. Off Isolation Measurement Setup

$$\text{Off Isolation} = 20 \cdot \text{Log} \left( \frac{V_{\text{OUT}}}{V_{\text{S}}} \right) \tag{1}$$

### 7.9 Crosstalk

Crosstalk is defined as the ratio of the signal at the drain pin (D) of a different channel, when a signal is applied at the source pin (Sx) of an on-channel.  15 shows the setup used to measure, and the equation used to calculate crosstalk.



 15. Crosstalk Measurement Setup

$$\text{Channel-to-Channel Crosstalk} = 20 \cdot \text{Log} \left( \frac{V_{\text{OUT}}}{V_{\text{S}}} \right) \tag{2}$$

### 7.10 Bandwidth

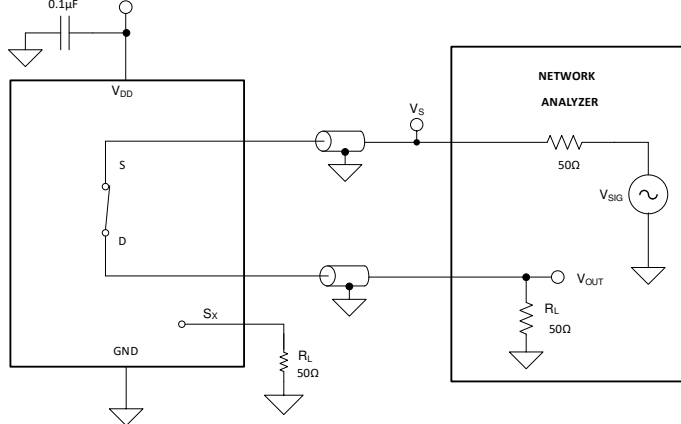
Bandwidth is defined as the range of frequencies that are attenuated by less than 3 dB when the input is applied to the source pin (Sx) of an on-channel, and the output is measured at the drain pin (D) of the device.  16 shows the setup used to measure bandwidth.

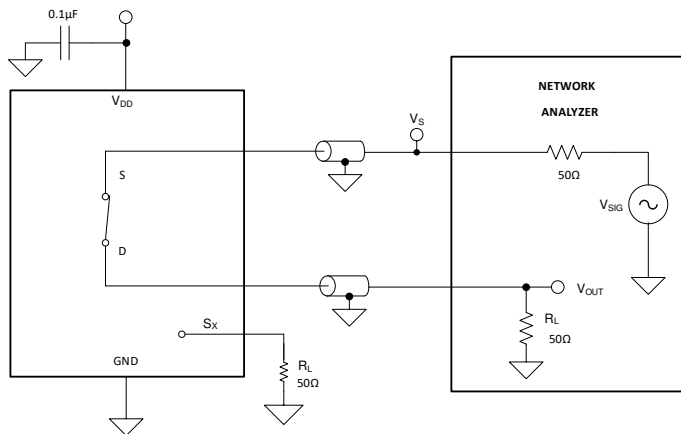

 16. Bandwidth Measurement Setup

## 8 Detailed Description

### 8.1 Functional Block Diagram

The TMUX1204 is a 4:1, single-ended (1-ch.), mux. Each channel is turned on or turned off based on the state of the address lines and the enable pin.

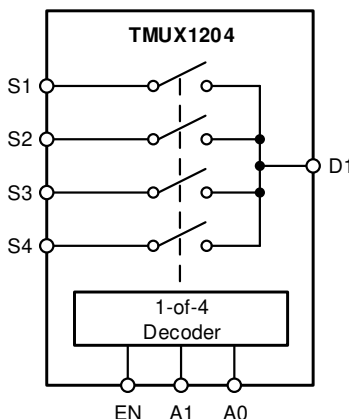

✉ 17. TMUX1204 Functional Block Diagrams

### 8.2 Feature Description

#### 8.2.1 Bidirectional Operation

The TMUX1204 conducts equally well from source ( $S_x$ ) to drain (D) or from drain (D) to source ( $S_x$ ). Each channel has very similar characteristics in both directions and supports both analog and digital signals.

#### 8.2.2 Rail to Rail Operation

The valid signal path input/output voltage for TMUX1204 ranges from GND to  $V_{DD}$ .

#### 8.2.3 1.8 V Logic Compatible Inputs

The TMUX1204 has 1.8-V logic compatible control for all logic control inputs. The logic input thresholds scale with supply but still provide 1.8-V logic control when operating at 5.5 V supply voltage. 1.8-V logic level inputs allows the TMUX1204 to interface with processors that have lower logic I/O rails and eliminates the need for an external translator, which saves both space and BOM cost. For more information on 1.8 V logic implementations refer to [Simplifying Design with 1.8 V logic Muxes and Switches](#)

#### 8.2.4 Fail-Safe Logic

The TMUX1204 supports Fail-Safe Logic on the control input pins (EN, A0, A1) allowing for operation up to 5.5 V, regardless of the state of the supply pin. This feature allows voltages on the control pins to be applied before the supply pin, protecting the device from potential damage. Fail-Safe Logic minimizes system complexity by removing the need for power supply sequencing on the logic control pins. For example, the Fail-Safe Logic feature allows the select pins of the TMUX1204 to be ramped to 5.5 V while  $V_{DD} = 0$  V. Additionally, the feature enables operation of the TMUX1204 with  $V_{DD} = 1.2$  V while allowing the select pins to interface with a logic level of another device up to 5.5 V.

### 8.3 Device Functional Modes

When the EN pin of the TMUX1204 is pulled high, one of the switches is closed based on the state of the address lines. When the EN pin is pulled low, all the switches are in an open state irrespective of the state of the address lines. The EN pin can be connected to  $V_{DD}$  (as high as 5.5 V).

The TMUX1204 can be operated without any external components except for the supply decoupling capacitors. Unused logic control pins should be tied to GND or  $V_{DD}$  in order to ensure the device does not consume additional current as highlighted in [Implications of Slow or Floating CMOS Inputs](#). Unused signal path inputs (Sx or D) should be connected to GND.

### 8.4 Truth Tables

and [表 1](#) show the truth tables for the TMUX1204, respectively.

**表 1. TMUX1204 Truth Table**

EN	A1	A0	Selected Channel Connected To Drain (D) Pin
0	X <sup>(1)</sup>	X <sup>(1)</sup>	All channels are off
1	0	0	Channel S1
1	0	1	Channel S2
1	1	0	Channel S3
1	1	1	Channel S4

(1) X denotes *don't care*.

## 9 Application and Implementation

### 注

Information in the following applications sections is not part of the TI component specification, and TI does not warrant its accuracy or completeness. TI's customers are responsible for determining suitability of components for their purposes. Customers should validate and test their design implementation to confirm system functionality.

### 9.1 Application Information

The TMUX12xx family offers good system performance across a wide operating supply (1.08V to 5.5V). These devices include 1.8V logic compatible control input pins that enable operation in systems with 1.8V I/O rails. Additionally, the control input pins support Fail-Safe Logic which allows for operation up to 5.5V, regardless of the state of the supply pin. This protection stops the logic pins from back-powering the supply rail. These features make the TMUX12xx a family of general purpose multiplexers and switches that can reduce system complexity, board size, and overall system cost.

### 9.2 Typical Application

One useful application to take advantage of the TMUX1204 features is multiplexing various signals into an ADC that is integrated into a MCU. Utilizing an integrated ADC in a MCU allows a system to minimize cost with a potential tradeoff of system performance when compared to an external ADC. The multiplexer allows for multiple inputs/sensors to be monitored with a single ADC pin of the device, which is critical in systems with limited I/O.



图 18. Multiplexing Signals to Integrated ADC

### 9.3 Design Requirements

For this design example, use the parameters listed in 表 2.

表 2. Design Parameters

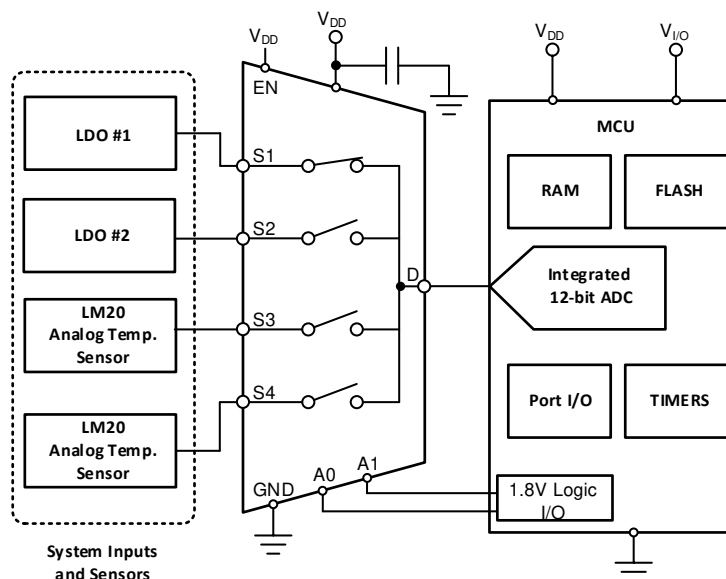
PARAMETERS	VALUES
Supply ( $V_{DD}$ )	5.0 V
I/O signal range	0 V to $V_{DD}$ (Rail to Rail)
Control logic thresholds	1.8 V compatible

## 9.4 Detailed Design Procedure

The TMUX1204 can be operated without any external components except for the supply decoupling capacitors. If the parts desired power-up state is disabled, the enable pin should have a weak pull-down resistor and be controlled by the MCU via GPIO. All inputs being muxed to the ADC of the MCU must fall within the recommend operating conditions of the TMUX1204 including signal range and continuous current. For this design with a supply of 5 V the signal range can be 0 V to 5 V and the max continuous current can be 30 mA.

## 9.5 Application Curve

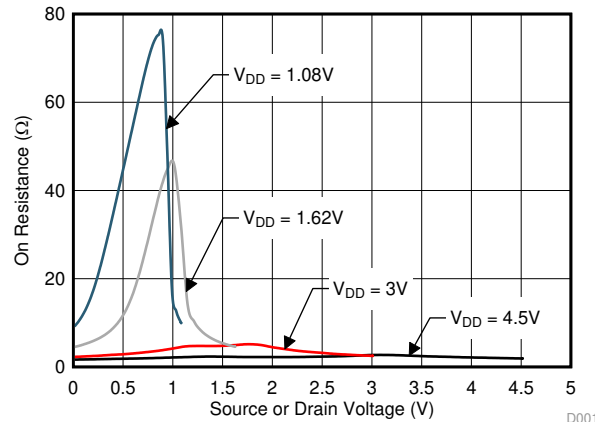

$T_A = 25^\circ\text{C}$

19. On-Resistance vs Source or Drain Voltage

## 10 Power Supply Recommendations

The TMUX1204 operates across a wide supply range of 1.08 V to 5.5 V. Do not exceed the absolute maximum ratings because stresses beyond the listed ratings can cause permanent damage to the devices.

Power-supply bypassing improves noise margin and prevents switching noise propagation from the  $V_{DD}$  supply to other components. Good power-supply decoupling is important to achieve optimum performance. For improved supply noise immunity, use a supply decoupling capacitor ranging from 0.1  $\mu\text{F}$  to 10  $\mu\text{F}$  from  $V_{DD}$  to ground. Place the bypass capacitors as close to the power supply pins of the device as possible using low-impedance connections. TI recommends using multi-layer ceramic chip capacitors (MLCCs) that offer low equivalent series resistance (ESR) and inductance (ESL) characteristics for power-supply decoupling purposes. For very sensitive systems, or for systems in harsh noise environments, avoiding the use of vias for connecting the capacitors to the device pins may offer superior noise immunity. The use of multiple vias in parallel lowers the overall inductance and is beneficial for connections to ground planes.

## 11 Layout

### 11.1 Layout Guidelines

#### 11.1.1 Layout Information

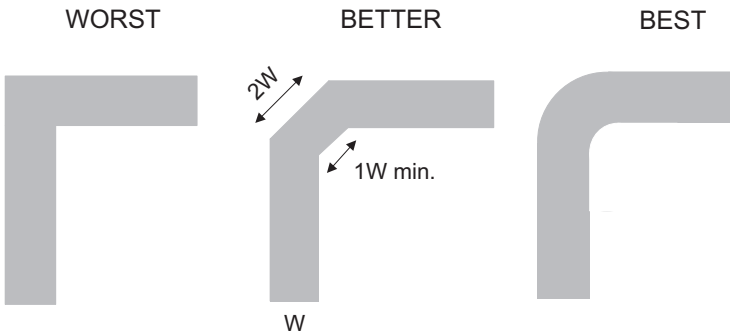
When a PCB trace turns a corner at a 90° angle, a reflection can occur. A reflection occurs primarily because of the change of width of the trace. At the apex of the turn, the trace width increases to 1.414 times the width. This increase upsets the transmission-line characteristics, especially the distributed capacitance and self-inductance of the trace which results in the reflection. Not all PCB traces can be straight and therefore some traces must turn corners.  20 shows progressively better techniques of rounding corners. Only the last example (BEST) maintains constant trace width and minimizes reflections.

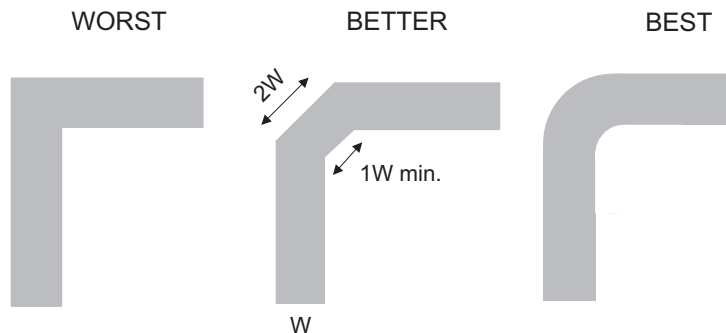

 20. Trace Example

Route high-speed signals using a minimum of vias and corners which reduces signal reflections and impedance changes. When a via must be used, increase the clearance size around it to minimize its capacitance. Each via introduces discontinuities in the signal's transmission line and increases the chance of picking up interference from the other layers of the board. Be careful when designing test points, through-hole pins are not recommended at high frequencies.

 21 illustrates an example of a PCB layout with the TMUX1204. Some key considerations are:

- Decouple the  $V_{DD}$  pin with a 0.1- $\mu\text{F}$  capacitor, placed as close to the pin as possible. Make sure that the capacitor voltage rating is sufficient for the  $V_{DD}$  supply.
- Keep the input lines as short as possible.
- Use a solid ground plane to help reduce electromagnetic interference (EMI) noise pickup.
- Do not run sensitive analog traces in parallel with digital traces. Avoid crossing digital and analog traces if possible, and only make perpendicular crossings when necessary.

### 11.2 Layout Example

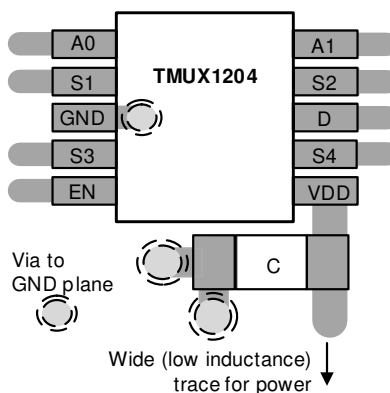

 21. TMUX1204 Layout Example

## 12 デバイスおよびドキュメントのサポート

### 12.1 ドキュメントのサポート

#### 12.1.1 関連資料

テキサス・インスツルメンツ、『[1.8Vロジックのマルチプレクサおよびスイッチにおける設計の単純化](#)』

テキサス・インスツルメンツ、『[QFN/SONのPCB実装](#)』

テキサス・インスツルメンツ、『[クワッド・フラットパック・リード端子なしロジック・パッケージ](#)』

### 12.2 ドキュメントの更新通知を受け取る方法

ドキュメントの更新についての通知を受け取るには、[ti.com](http://ti.com)のデバイス製品フォルダを開いてください。右上の「アラートを受け取る」をクリックして登録すると、変更されたすべての製品情報に関するダイジェストを毎週受け取れます。変更の詳細については、修正されたドキュメントに含まれている改訂履歴をご覧ください。

### 12.3 コミュニティ・リソース

[TI E2E™ support forums](#) are an engineer's go-to source for fast, verified answers and design help — straight from the experts. Search existing answers or ask your own question to get the quick design help you need.

Linked content is provided "AS IS" by the respective contributors. They do not constitute TI specifications and do not necessarily reflect TI's views; see TI's [Terms of Use](#).

### 12.4 商標

E2E is a trademark of Texas Instruments.

### 12.5 静電気放電に関する注意事項



すべての集積回路は、適切なESD保護方法を用いて、取扱いと保存を行うようにして下さい。

静電気放電はわずかな性能の低下から完全なデバイスの故障に至るまで、様々な損傷を与えます。高精度の集積回路は、損傷に対して敏感であり、極めてわずかなパラメータの変化により、デバイスに規定された仕様に適合しなくなる場合があります。

### 12.6 Glossary

[SLYZ022](#) — *TI Glossary*.

This glossary lists and explains terms, acronyms, and definitions.

## 13 メカニカル、パッケージ、および注文情報

以降のページには、メカニカル、パッケージ、および注文に関する情報が記載されています。この情報は、そのデバイスについて利用可能な最新のデータです。このデータは予告なく変更されることがあり、ドキュメントが改訂される場合もあります。本データシートのブラウザ版を使用されている場合は、画面左側の説明をご覧ください。



**PACKAGING INFORMATION**

Orderable part number	Status (1)	Material type (2)	Package   Pins	Package qty   Carrier	RoHS (3)	Lead finish/ Ball material (4)	MSL rating/ Peak reflow (5)	Op temp (°C)	Part marking (6)
<a href="#">TMUX1204DGSR</a>	Active	Production	VSSOP (DGS)   10	2500   LARGE T&R	Yes	NIPDAUAG   SN	Level-1-260C-UNLIM	-40 to 125	1F6
TMUX1204DGSR.A	Active	Production	VSSOP (DGS)   10	2500   LARGE T&R	Yes	SN	Level-1-260C-UNLIM	-40 to 125	1F6
<a href="#">TMUX1204DQAR</a>	Active	Production	USON (DQA)   10	3000   LARGE T&R	Yes	NIPDAU	Level-1-260C-UNLIM	-40 to 125	204
TMUX1204DQAR.A	Active	Production	USON (DQA)   10	3000   LARGE T&R	Yes	NIPDAU	Level-1-260C-UNLIM	-40 to 125	204
TMUX1204DQARG4.A	Active	Production	USON (DQA)   10	3000   LARGE T&R	Yes	NIPDAU	Level-1-260C-UNLIM	-40 to 125	204

(1) **Status:** For more details on status, see our [product life cycle](#).

(2) **Material type:** When designated, preproduction parts are prototypes/experimental devices, and are not yet approved or released for full production. Testing and final process, including without limitation quality assurance, reliability performance testing, and/or process qualification, may not yet be complete, and this item is subject to further changes or possible discontinuation. If available for ordering, purchases will be subject to an additional waiver at checkout, and are intended for early internal evaluation purposes only. These items are sold without warranties of any kind.

(3) **RoHS values:** Yes, No, RoHS Exempt. See the [TI RoHS Statement](#) for additional information and value definition.

(4) **Lead finish/Ball material:** Parts may have multiple material finish options. Finish options are separated by a vertical ruled line. Lead finish/Ball material values may wrap to two lines if the finish value exceeds the maximum column width.

(5) **MSL rating/Peak reflow:** The moisture sensitivity level ratings and peak solder (reflow) temperatures. In the event that a part has multiple moisture sensitivity ratings, only the lowest level per JEDEC standards is shown. Refer to the shipping label for the actual reflow temperature that will be used to mount the part to the printed circuit board.

(6) **Part marking:** There may be an additional marking, which relates to the logo, the lot trace code information, or the environmental category of the part.

Multiple part markings will be inside parentheses. Only one part marking contained in parentheses and separated by a "-" will appear on a part. If a line is indented then it is a continuation of the previous line and the two combined represent the entire part marking for that device.

**Important Information and Disclaimer:** The information provided on this page represents TI's knowledge and belief as of the date that it is provided. TI bases its knowledge and belief on information provided by third parties, and makes no representation or warranty as to the accuracy of such information. Efforts are underway to better integrate information from third parties. TI has taken and continues to take reasonable steps to provide representative and accurate information but may not have conducted destructive testing or chemical analysis on incoming materials and chemicals. TI and TI suppliers consider certain information to be proprietary, and thus CAS numbers and other limited information may not be available for release.

In no event shall TI's liability arising out of such information exceed the total purchase price of the TI part(s) at issue in this document sold by TI to Customer on an annual basis.

**TAPE AND REEL INFORMATION**

**QUADRANT ASSIGNMENTS FOR PIN 1 ORIENTATION IN TAPE**

\*All dimensions are nominal

Device	Package Type	Package Drawing	Pins	SPQ	Reel Diameter (mm)	Reel Width W1 (mm)	A0 (mm)	B0 (mm)	K0 (mm)	P1 (mm)	W (mm)	Pin1 Quadrant
TMUX1204DGSR	VSSOP	DGS	10	2500	330.0	12.4	5.3	3.4	1.4	8.0	12.0	Q1
TMUX1204DGSR	VSSOP	DGS	10	2500	330.0	12.4	5.25	3.35	1.25	8.0	12.0	Q1
TMUX1204DQAR	USON	DQA	10	3000	180.0	9.5	1.18	2.68	0.72	4.0	8.0	Q1

## TAPE AND REEL BOX DIMENSIONS



\*All dimensions are nominal

Device	Package Type	Package Drawing	Pins	SPQ	Length (mm)	Width (mm)	Height (mm)
TMUX1204DGSR	VSSOP	DGS	10	2500	364.0	364.0	27.0
TMUX1204DGSR	VSSOP	DGS	10	2500	366.0	364.0	50.0
TMUX1204DQAR	USON	DQA	10	3000	189.0	185.0	36.0

# DGS0010A



# PACKAGE OUTLINE

## VSSOP - 1.1 mm max height

SMALL OUTLINE PACKAGE



4221984/A 05/2015

### NOTES:

1. All linear dimensions are in millimeters. Any dimensions in parenthesis are for reference only. Dimensioning and tolerancing per ASME Y14.5M.
2. This drawing is subject to change without notice.
3. This dimension does not include mold flash, protrusions, or gate burrs. Mold flash, protrusions, or gate burrs shall not exceed 0.15 mm per side.
4. This dimension does not include interlead flash. Interlead flash shall not exceed 0.25 mm per side.
5. Reference JEDEC registration MO-187, variation BA.

# EXAMPLE BOARD LAYOUT

DGS0010A

VSSOP - 1.1 mm max height

SMALL OUTLINE PACKAGE



LAND PATTERN EXAMPLE  
SCALE:10X

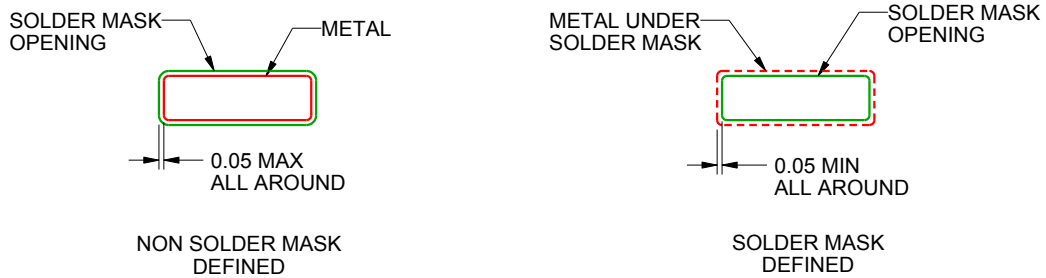

SOLDER MASK DETAILS  
NOT TO SCALE

4221984/A 05/2015

NOTES: (continued)

- 6. Publication IPC-7351 may have alternate designs.
- 7. Solder mask tolerances between and around signal pads can vary based on board fabrication site.

# EXAMPLE STENCIL DESIGN

DGS0010A

VSSOP - 1.1 mm max height

SMALL OUTLINE PACKAGE



SOLDER PASTE EXAMPLE  
BASED ON 0.125 mm THICK STENCIL  
SCALE:10X

4221984/A 05/2015

NOTES: (continued)

8. Laser cutting apertures with trapezoidal walls and rounded corners may offer better paste release. IPC-7525 may have alternate design recommendations.
9. Board assembly site may have different recommendations for stencil design.

## GENERIC PACKAGE VIEW

**DQA 10**

**USON - 0.55 mm max height**

1 x 2.5, 0.5 mm pitch

PLASTIC SMALL OUTLINE - NO LEAD

This image is a representation of the package family, actual package may vary.  
Refer to the product data sheet for package details.

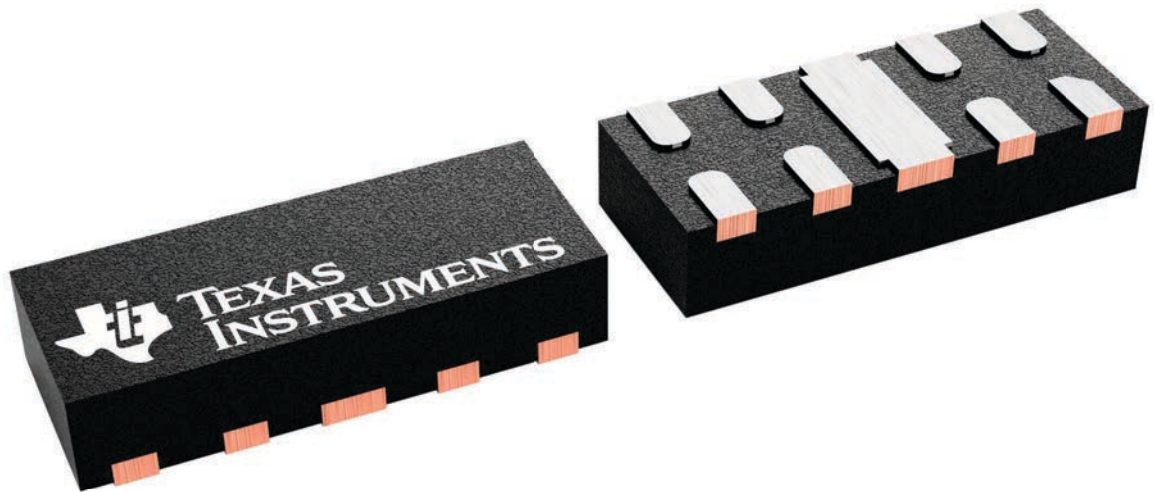

4230320/A

# DQA0010A



# PACKAGE OUTLINE

## USON - 0.55 mm max height

PLASTIC SMALL OUTLINE - NO LEAD

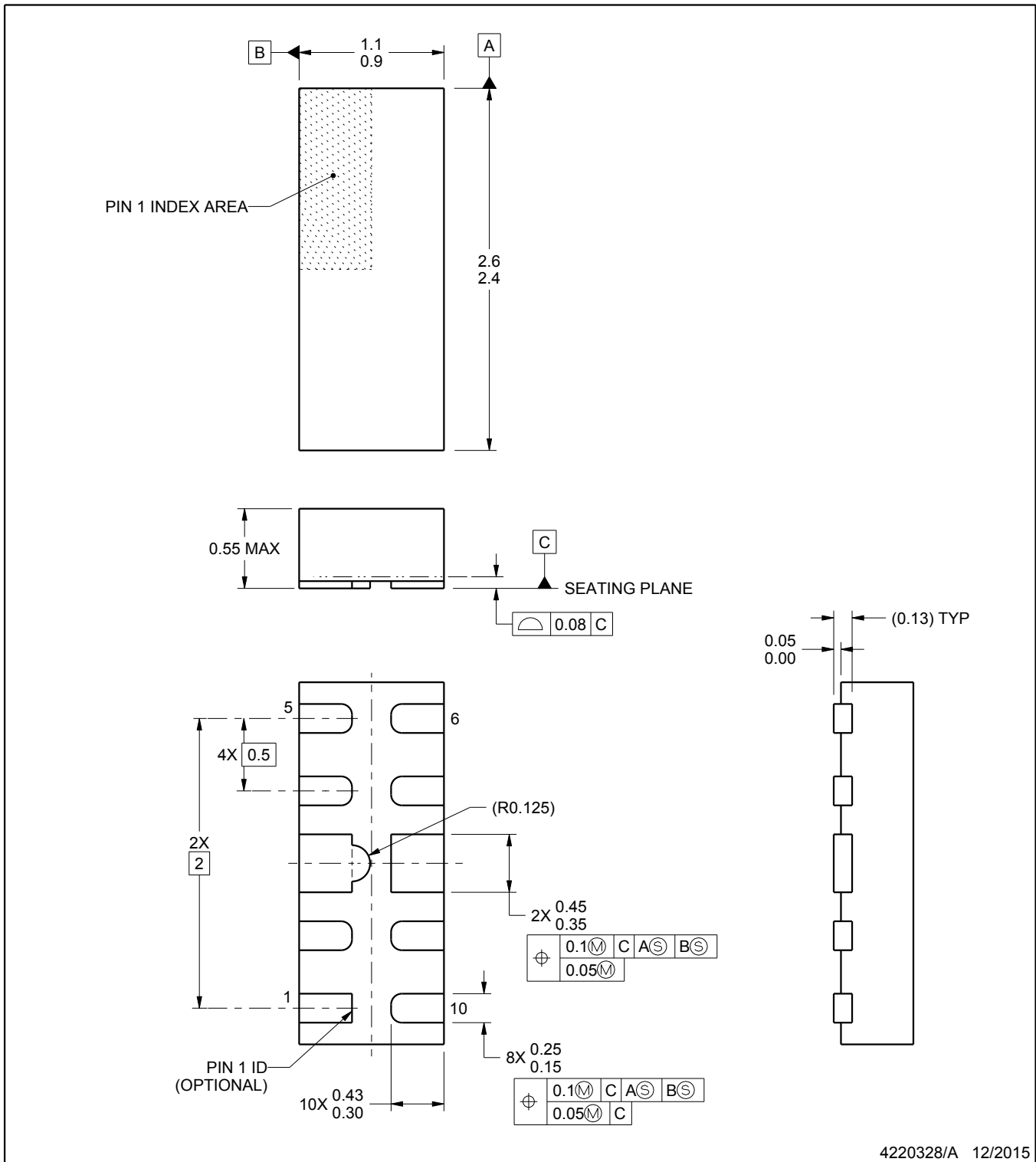

4220328/A 12/2015

NOTES:

1. All linear dimensions are in millimeters. Any dimensions in parenthesis are for reference only. Dimensioning and tolerancing per ASME Y14.5M.
2. This drawing is subject to change without notice.



# EXAMPLE BOARD LAYOUT

DQA0010A

USON - 0.55 mm max height

PLASTIC SMALL OUTLINE - NO LEAD

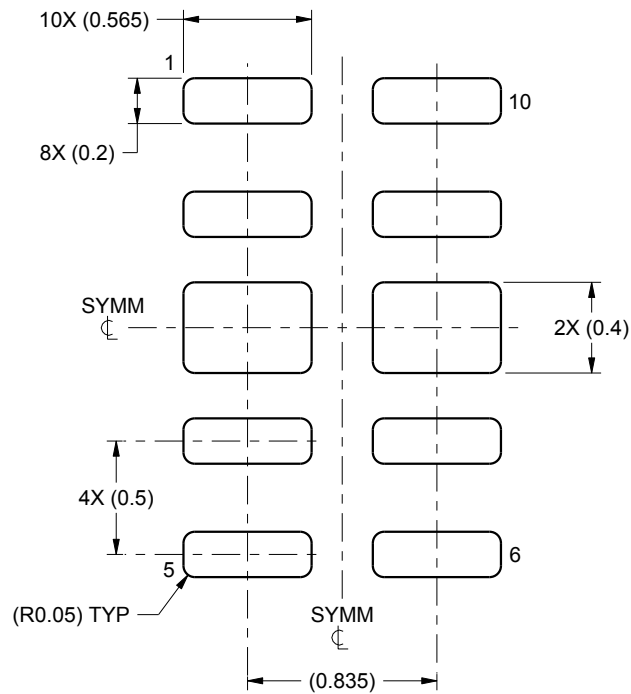

LAND PATTERN EXAMPLE  
SCALE:30X

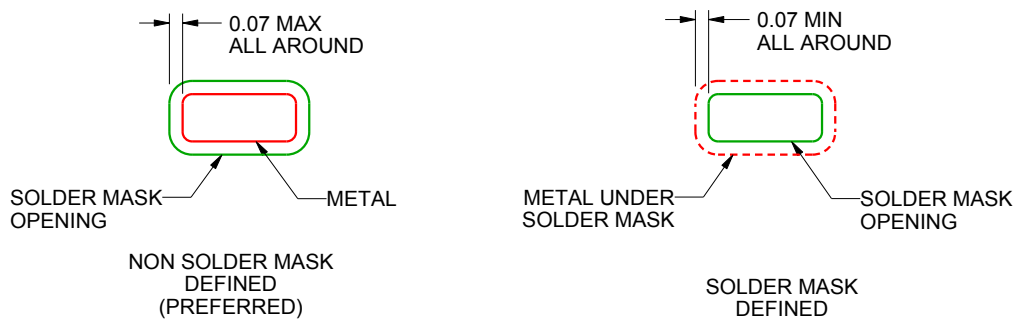

SOLDER MASK DETAILS

4220328/A 12/2015

NOTES: (continued)

3. For more information, see Texas Instruments literature number SLUA271 ([www.ti.com/lit/slua271](http://www.ti.com/lit/slua271)).

# EXAMPLE STENCIL DESIGN

DQA0010A

USON - 0.55 mm max height

PLASTIC SMALL OUTLINE - NO LEAD

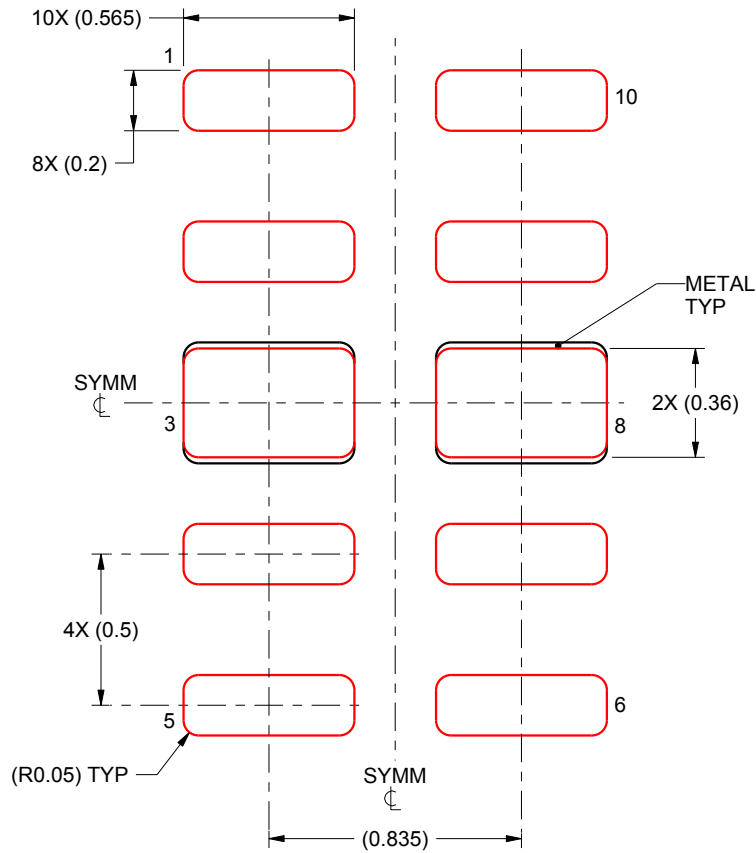

SOLDER PASTE EXAMPLE  
BASED ON 0.1 mm THICK STENCIL

EXPOSED PADS 3 & 8:  
90% PRINTED SOLDER COVERAGE BY AREA UNDER PACKAGE  
SCALE:40X

4220328/A 12/2015

NOTES: (continued)

4. Laser cutting apertures with trapezoidal walls and rounded corners may offer better paste release. IPC-7525 may have alternate design recommendations.

## 重要なお知らせと免責事項

テキサス・インスツルメンツは、技術データと信頼性データ(データシートを含みます)、設計リソース(リファレンス デザインを含みます)、アプリケーションや設計に関する各種アドバイス、Web ツール、安全性情報、その他のリソースを、欠陥が存在する可能性のある「現状のまま」提供しており、商品性および特定目的に対する適合性の黙示保証、第三者の知的財産権の非侵害保証を含むいかなる保証も、明示的または黙示的にかかわらず拒否します。

これらのリソースは、テキサス・インスツルメンツ製品を使用する設計の経験を積んだ開発者への提供を意図したものです。(1) お客様のアプリケーションに適したテキサス・インスツルメンツ製品の選定、(2) お客様のアプリケーションの設計、検証、試験、(3) お客様のアプリケーションに該当する各種規格や、その他のあらゆる安全性、セキュリティ、規制、または他の要件への確実な適合に関する責任を、お客様のみが単独で負うものとし、ます。

上記の各種リソースは、予告なく変更される可能性があります。これらのリソースは、リソースで説明されているテキサス・インスツルメンツ製品を使用するアプリケーションの開発の目的でのみ、テキサス・インスツルメンツはその使用をお客様に許諾します。これらのリソースに関して、他の目的で複製することや掲載することは禁止されています。テキサス・インスツルメンツや第三者の知的財産権のライセンスが付与されている訳ではありません。お客様は、これらのリソースを自身で使用した結果発生するあらゆる申し立て、損害、費用、損失、責任について、テキサス・インスツルメンツおよびその代理人を完全に補償するものとし、テキサス・インスツルメンツは一切の責任を拒否します。

テキサス・インスツルメンツの製品は、[テキサス・インスツルメンツの販売条件](#)、または [ti.com](https://www.ti.com) やかかるテキサス・インスツルメンツ製品の関連資料などのいずれかを通じて提供する適用可能な条項の下で提供されています。テキサス・インスツルメンツがこれらのリソースを提供することは、適用されるテキサス・インスツルメンツの保証または他の保証の放棄の拡大や変更を意味するものではありません。

お客様がいかなる追加条項または代替条項を提案した場合でも、テキサス・インスツルメンツはそれらに異議を唱え、拒否します。

郵送先住所：Texas Instruments, Post Office Box 655303, Dallas, Texas 75265  
Copyright © 2025, Texas Instruments Incorporated