

OPT3006 超薄型周辺光センサ

1 特長

- 高精度の光フィルタリングにより人間の目に適合
 - IRの99%超(標準値)を除去
- 自動フルスケール設定機能により、ソフトウェアが簡素化され、最適な構成を実現
- 測定範囲 0.01ルクス～83kルクス
- 自動ゲイン範囲設定により23ビットの実効ダイナミック・レンジを実現
- 12個のバイナリ重み付け、フルスケール範囲設定: 範囲間の一致精度0.2%未満(標準値)
- 低い動作電流: 1.8 μ A (標準値)
- 動作温度範囲: -40 $^{\circ}$ C～85 $^{\circ}$ C
- 広い電源電圧範囲: 1.6V～3.6V
- 5.5V対応のI/O
- 柔軟な割り込みシステム
- 小さなフォームファクタ
 - 0.856mm \times 0.946mm \times 0.226mm PicoStar™パッケージ
- OPT3006はOPT3001の小型版

2 アプリケーション

- スマートウォッチ
- ウェアラブル・エレクトロニクス
- 健康フィットネス・バンド
- ディスプレイのバックライト制御
- 照明制御システム
- タブレットおよびノートブック・コンピュータ
- カメラ

スペクトル応答: OPT3006と人間の目との比較

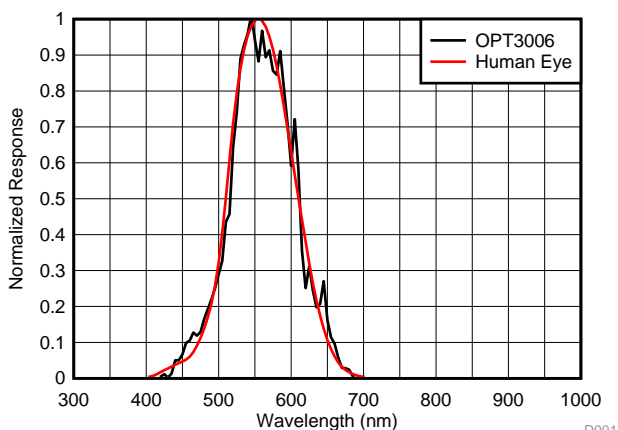

3 概要

OPT3006はシングル・チップのルクス・メーターで、人間の目と同じレベルでの可視光の照度を測定できます。OPT3006は超小型のPicoStarパッケージで供給されるため、小さなスペースに収まります。

センサの高精度のスペクトル応答は、人間の目の明順応とほぼ一致しています。強力な赤外線(IR)除去により、光源にかかわらず人間の目を見た場合と同じ照度を正確に測定できます。また、強力なIR除去機能により、暗色のガラス下にセンサを設置する必要がある場合でも高い精度を維持できます。OPT3006は多くの場合にバックライトICまたは照明制御システムと組み合わせて使用され、人間向けの照明環境を実現します。フォトダイオード、光抵抗、または性能の低い環境光センサの代替品として理想的です。

内蔵のフルスケール設定機能により、手動でフルスケール範囲を選択する必要がなく、0.01ルクスから83kルクスまでの範囲を測定できます。この機能により、23ビットの実効ダイナミック・レンジにわたって光の測定が可能です。

システム統合のために、柔軟なデジタル動作が可能です。連続的な測定も、単回のみでの測定も実行できます。制御および割り込みシステムは自律的に動作するため、プロセッサがスリープ中でもセンサが適切なウェイクアップ・イベントを調べ、割り込みピンにより通知します。デジタル出力はI²CおよびSMBus互換の2線式シリアル・インターフェイスで通知されます。

低消費電力と、低い電源電圧で動作することから、OPT3006によりバッテリー駆動システムのバッテリー動作時間を延長できます。

製品情報(1)

型番	パッケージ	本体サイズ(公称)
OPT3006	PicoStar (6)	0.856mm \times 0.946mm \times 0.226mm

(1) 提供されているすべてのパッケージについては、巻末のパッケージについての補足情報を参照してください。

ブロック図

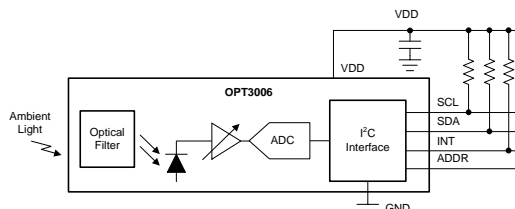

目次

1	特長	1	7.6	Register Maps	19
2	アプリケーション	1	8	Application and Implementation	27
3	概要	1	8.1	Application Information	27
4	改訂履歴	2	8.2	Typical Application	28
5	Pin Configuration and Functions	3	8.3	Do's and Don'ts	31
6	Specifications	4	9	Power-Supply Recommendations	31
6.1	Absolute Maximum Ratings	4	10	Layout	32
6.2	ESD Ratings	4	10.1	Layout Guidelines	32
6.3	Recommended Operating Conditions	4	10.2	Soldering and Handling Recommendations	32
6.4	Thermal Information	4	10.3	Layout Example	34
6.5	Electrical Characteristics	5	11	デバイスおよびドキュメントのサポート	35
6.6	Timing Requirements	6	11.1	ドキュメントのサポート	35
6.7	Typical Characteristics	7	11.2	ドキュメントの更新通知を受け取る方法	35
7	Detailed Description	10	11.3	コミュニティ・リソース	35
7.1	Overview	10	11.4	商標	35
7.2	Functional Block Diagram	10	11.5	静電気放電に関する注意事項	35
7.3	Feature Description	11	11.6	Glossary	35
7.4	Device Functional Modes	13	12	メカニカル、パッケージ、および注文情報	35
7.5	Programming	16			

4 改訂履歴

日付	改訂内容	注
2016年10月	*	初版

5 Pin Configuration and Functions

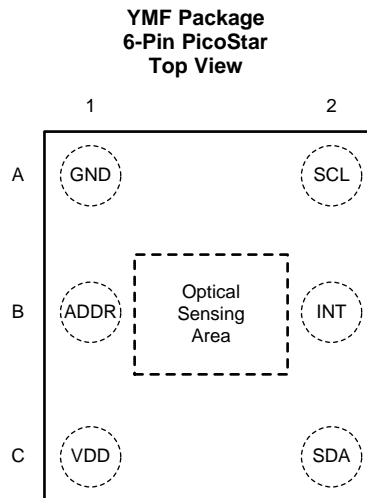

Pin Functions

PIN		I/O	DESCRIPTION
NO.	NAME		
A1	GND	Power	Ground
B1	ADDR	Digital input	Address pin. This pin sets the LSBs of the I ² C address.
C1	VDD	Power	Device power. Connect to a 1.6-V to 3.6-V supply.
A2	SCL	Digital input	I ² C clock. Connect with a 10-kΩ resistor to a 1.6-V to 5.5-V supply.
B2	INT	Digital output	Interrupt output open-drain. Connect with a 10-kΩ resistor to a 1.6-V to 5.5-V supply.
C2	SDA	Digital input/output	I ² C data. Connect with a 10-kΩ resistor to a 1.6-V to 5.5-V supply.

6 Specifications

6.1 Absolute Maximum Ratings⁽¹⁾

		MIN	MAX	UNIT
Voltage	VDD to GND	-0.5	6	V
	SDA, SCL, INT, and ADDR to GND	-0.5	6	V
Current into any pin			10	mA
Temperature	Junction		150	°C
	Storage, T _{stg}	-65	150 ⁽²⁾	°C

- (1) Stresses beyond those listed under *Absolute Maximum Ratings* may cause permanent damage to the device. These are stress ratings only, and do not imply functional operation of the device at these or any other conditions beyond those indicated under *Recommended Operating Conditions*. Exposure to absolute-maximum-rated conditions for extended periods may affect device reliability.
- (2) Long exposure to temperatures higher than 105°C can cause package discoloration, spectral distortion, and measurement inaccuracy.

6.2 ESD Ratings

			VALUE	UNIT
V _(ESD)	Electrostatic discharge	Human-body model (HBM), per ANSI/ESDA/JEDEC JS-001 ⁽¹⁾	±2000	V
		Charged-device model (CDM), per JEDEC specification JESD22-C101 ⁽²⁾	±500	

- (1) JEDEC document JEP155 states that 500-V HBM allows safe manufacturing with a standard ESD control process.
- (2) JEDEC document JEP157 states that 250-V CDM allows safe manufacturing with a standard ESD control process.

6.3 Recommended Operating Conditions

	MIN	NOM	MAX	UNIT
Operating temperature	-40		85	°C
Operating power-supply voltage	1.6		3.6	V

6.4 Thermal Information

THERMAL METRIC ⁽¹⁾		OPT3006	UNIT
		YMF (PicoStar)	
		6 PINS	
R _{θJA}	Junction-to-ambient thermal resistance	122.8	°C/W
R _{θJC(top)}	Junction-to-case (top) thermal resistance	1.4	°C/W
R _{θJB}	Junction-to-board thermal resistance	34.9	°C/W
ψ _{JT}	Junction-to-top characterization parameter	0.8	°C/W
ψ _{JB}	Junction-to-board characterization parameter	35.3	°C/W

- (1) For more information about traditional and new thermal metrics, see the [Semiconductor and IC Package Thermal Metrics](#) application report.

6.5 Electrical Characteristics

At $T_A = 25^\circ\text{C}$, $V_{DD} = 3.3\text{ V}$, 800-ms conversion time ($CT = 1$)⁽¹⁾, automatic full-scale range ($RN[3:0] = 1100b$)⁽¹⁾, white LED, and normal-angle incidence of light, unless otherwise specified.

PARAMETER	TEST CONDITIONS	MIN	TYP	MAX	UNIT	
OPTICAL						
Peak irradiance spectral responsivity			550		nm	
Resolution (LSB)	Lowest full-scale range, $RN[3:0] = 0000b$ ⁽¹⁾		0.01		lux	
Full-scale illuminance			83865.6		lux	
Measurement output result	0.64 lux per ADC code, 2620.80 lux full-scale ($RN[3:0] = 0110$) ⁽¹⁾ , 2000 lux input ⁽²⁾	2500	3125	3750	ADC codes	
		1600	2000	2400	lux	
Relative accuracy between gain ranges ⁽³⁾			0.2%			
Infrared response (850 nm) ⁽²⁾			0.2%			
Light source variation (incandescent, halogen, fluorescent)	Bare device, no cover glass		4%			
Linearity	Input illuminance > 40 lux		2%			
	Input illuminance < 40 lux		5%			
Measurement drift across temperature	Input illuminance = 2000 lux		0.01		%/°C	
Dark condition, ADC output	0.01 lux per ADC code		0	3	ADC codes	
			0	0.03	lux	
Half-power angle	50% of full-power reading		44		degrees	
PSRR	Power-supply rejection ratio	V_{DD} at 3.6 V and 1.6 V	0.1		%/V ⁽⁴⁾	
POWER SUPPLY						
V_{DD}	Operating range		1.6	3.6	V	
V_{PC}	Operating range of I ² C pull-up resistor	I ² C pull-up resistor, $V_{DD} \leq V_{PC}$	1.6	5.5	V	
I_Q	Quiescent current	Dark	Active, $V_{DD} = 3.6\text{ V}$	1.8	2.5	μA
			Shutdown ($M[1:0] = 00$) ⁽¹⁾ , $V_{DD} = 3.6\text{ V}$	0.3	0.47	μA
		Full-scale lux	Active, $V_{DD} = 3.6\text{ V}$	3.7		μA
			Shutdown, ($M[1:0] = 00$) ⁽¹⁾	0.4		μA
POR	Power-on-reset threshold	$T_A = 25^\circ\text{C}$	0.8		V	
DIGITAL						
	I/O pin capacitance		3		pF	
	Total integration time ⁽⁵⁾	($CT = 1$) ⁽¹⁾ , 800-ms mode, fixed lux range	720	800	880	ms
		($CT = 0$) ⁽¹⁾ , 100-ms mode, fixed lux range	90	100	110	ms
V_{IL}	Low-level input voltage (SDA, SCL, and ADDR)		0	$0.3 \times V_{DD}$	V	
V_{IH}	High-level input voltage (SDA, SCL, and ADDR)		$0.7 \times V_{DD}$	5.5	V	
I_{IL}	Low-level input current (SDA, SCL, and ADDR)		0.01	0.25 ⁽⁶⁾	μA	
V_{OL}	Low-level output voltage (SDA and INT)	$I_{OL} = 3\text{ mA}$		0.32	V	
I_{ZH}	Output logic high, high-Z leakage current (SDA, INT)	Pin at V_{DD}	0.01	0.25 ⁽⁶⁾	μA	
TEMPERATURE						
	Specified temperature range		-40	85	°C	

(1) Refers to a control field within the configuration register.

(2) Tested with the white LED calibrated to 2k lux and an 850-nm LED.

(3) Characterized by measuring fixed near-full-scale light levels on the higher adjacent full-scale range setting.

(4) PSRR is the percent change of the measured lux output from its current value, divided by the change in power supply voltage, as characterized by results from 3.6-V and 1.6-V power supplies.

(5) The conversion time, from start of conversion until the data are ready to be read, is the integration time plus 3 ms.

(6) The specified leakage current is dominated by the production test equipment limitations. Typical values are much smaller.

6.6 Timing Requirements⁽¹⁾

		MIN	TYP	MAX	UNIT
I²C FAST MODE					
f_{SCL}	SCL operating frequency	0.01		0.4	MHz
t_{BUF}	Bus free time between stop and start	1300			ns
t_{HDSTA}	Hold time after repeated start	600			ns
t_{SUSTA}	Setup time for repeated start	600			ns
t_{SUSTO}	Setup time for stop	600			ns
t_{HDDAT}	Data hold time	20		900	ns
t_{SUDAT}	Data setup time	100			ns
t_{LOW}	SCL clock low period	1300			ns
t_{HIGH}	SCL clock high period	600			ns
t_{RC} and t_{FC}	Clock rise and fall time			300	ns
t_{RD} and t_{FD}	Data rise and fall time			300	ns
t_{TIMEO}	Bus timeout period. If the SCL line is held low for this duration of time, the bus state machine is reset.		28		ms
I²C HIGH-SPEED MODE					
f_{SCL}	SCL operating frequency	0.01		2.6	MHz
t_{BUF}	Bus free time between stop and start	160			ns
t_{HDSTA}	Hold time after repeated start	160			ns
t_{SUSTA}	Setup time for repeated start	160			ns
t_{SUSTO}	Setup time for stop	160			ns
t_{HDDAT}	Data hold time	20		140	ns
t_{SUDAT}	Data setup time	20			ns
t_{LOW}	SCL clock low period	240			ns
t_{HIGH}	SCL clock high period	60			ns
t_{RC} and t_{FC}	Clock rise and fall time			40	ns
t_{RD} and t_{FD}	Data rise and fall time			80	ns
t_{TIMEO}	Bus timeout period. If the SCL line is held low for this duration of time, the bus state machine is reset.		28		ms

(1) All timing parameters are referenced to low and high voltage thresholds of 30% and 70%, respectively, of final settled value.

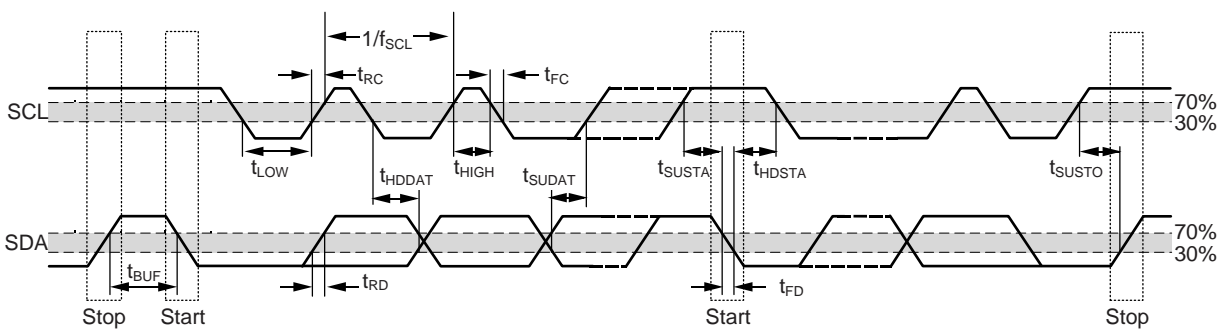

Figure 1. I²C Detailed Timing Diagram

6.7 Typical Characteristics

At $T_A = 25^\circ\text{C}$, $V_{DD} = 3.3\text{ V}$, 800-ms conversion time ($CT = 1$), automatic full-scale range ($RN[3:0] = 1100b$), white LED, and normal-angle incidence of light, unless otherwise specified.

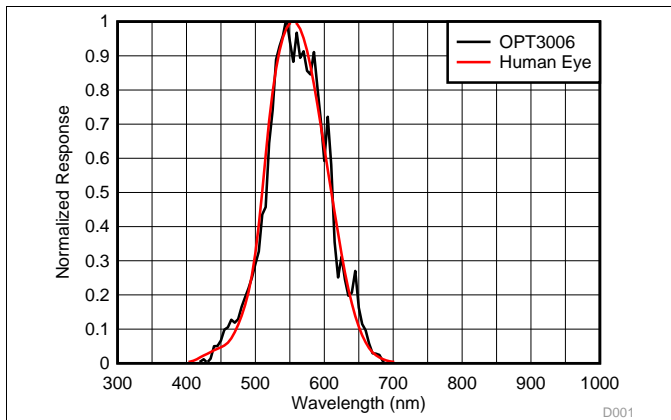

Figure 2. Spectral Response vs Wavelength

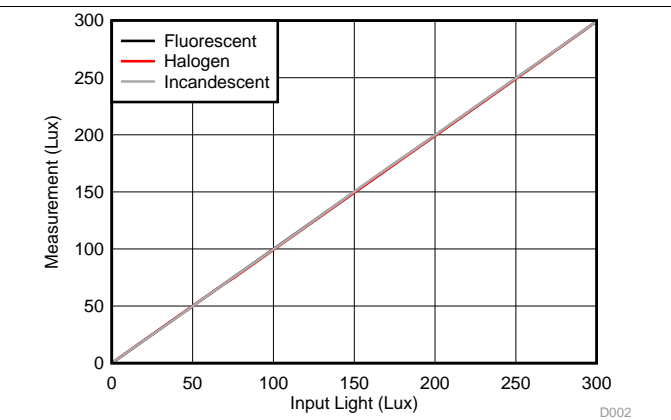

Figure 3. Output Response vs Input Illuminance, Multiple Light Sources (Fluorescent, Halogen, Incandescent)

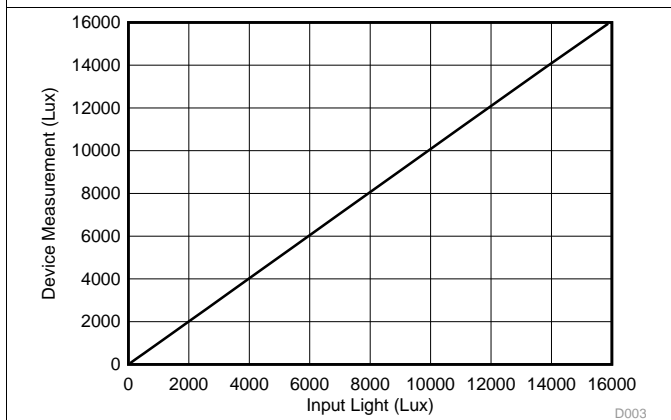

Figure 4. Output Response vs Input Illuminance (Higher Range = 0 lux to 16k lux)

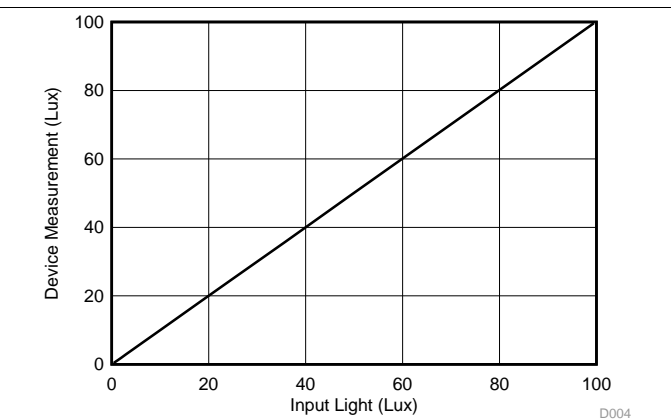

Figure 5. Output Response vs Input Illuminance (Mid Range = 0 lux to 100 lux)

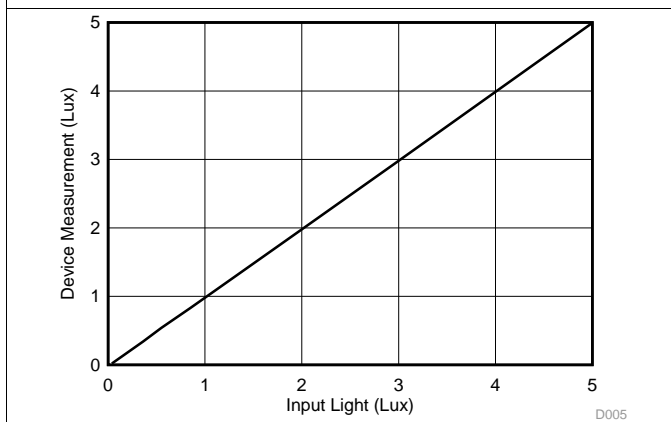

Figure 6. Output Response vs Input Illuminance (Low Range = 0 lux to 5 lux)

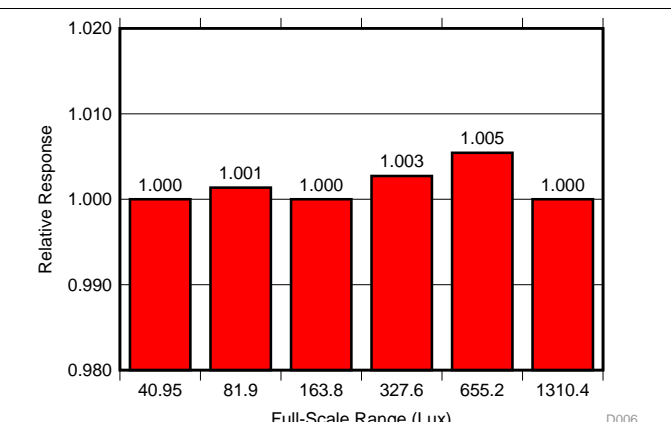

Figure 7. Full-Scale-Range Matching (Lowest 7 Ranges)

Typical Characteristics (continued)

At $T_A = 25^\circ\text{C}$, $V_{DD} = 3.3\text{ V}$, 800-ms conversion time ($CT = 1$), automatic full-scale range ($RN[3:0] = 1100b$), white LED, and normal-angle incidence of light, unless otherwise specified.

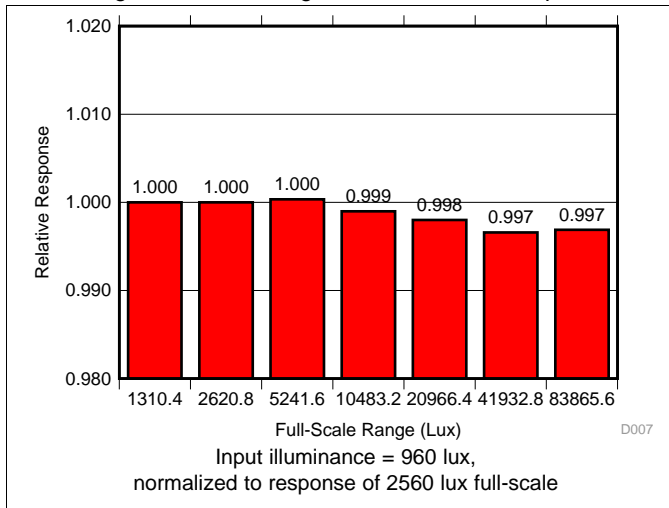

Figure 8. Full-Scale-Range Matching (Highest 6 Ranges)

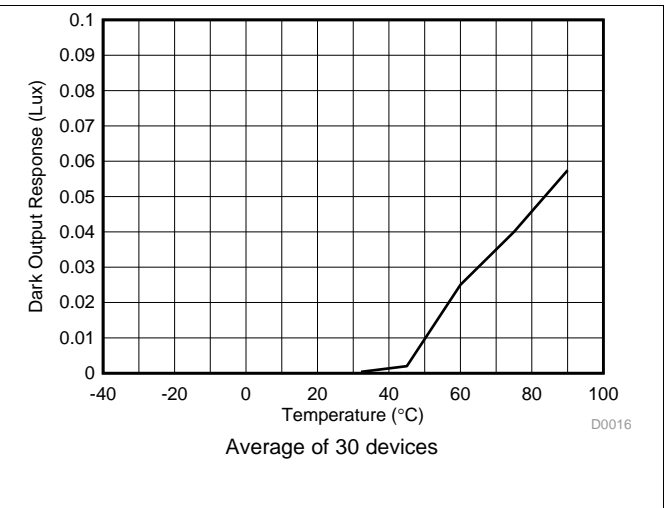

Figure 9. Dark Response vs Temperature

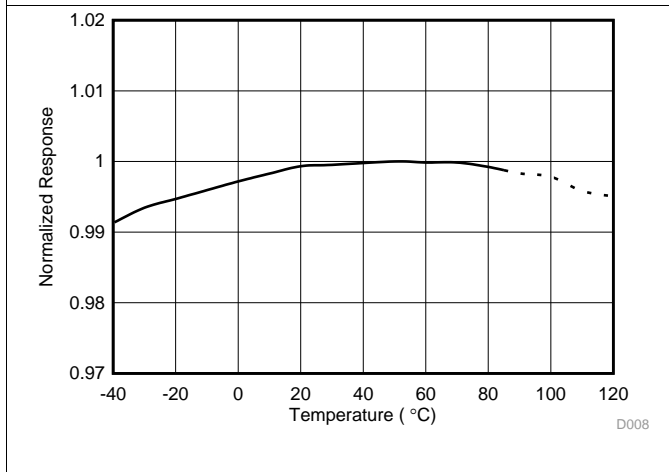

Figure 10. Normalized Response vs Temperature

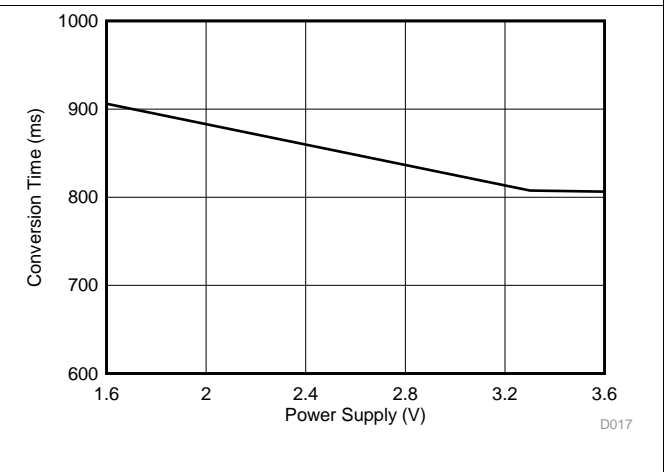

Figure 11. Conversion Time vs Power Supply

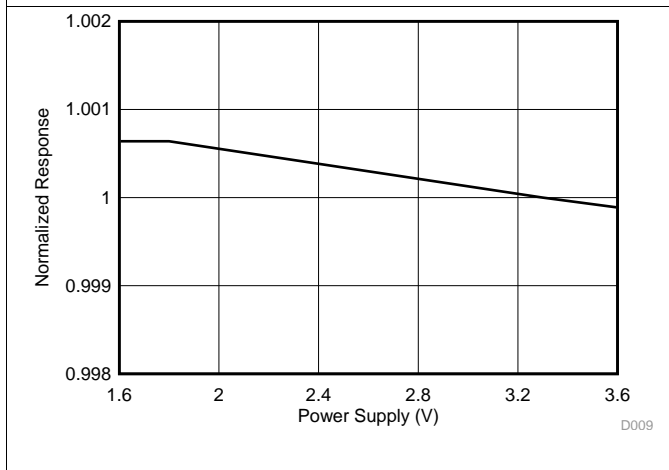

Figure 12. Normalized Response vs Power-Supply Voltage

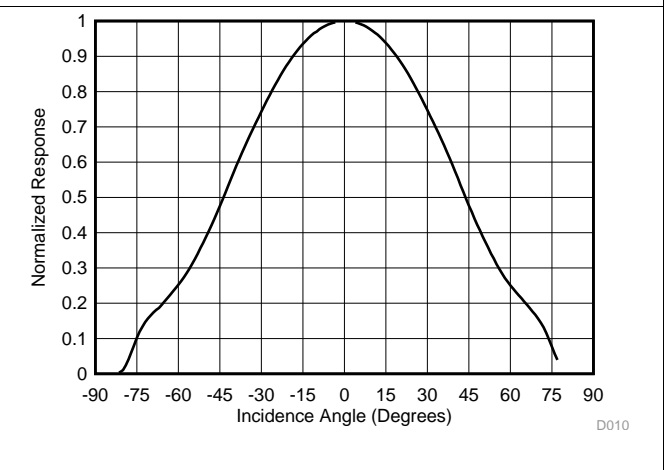

Figure 13. Normalized Response vs Illuminance Angle

Typical Characteristics (continued)

At $T_A = 25^\circ\text{C}$, $V_{DD} = 3.3\text{ V}$, 800-ms conversion time ($CT = 1$), automatic full-scale range ($RN[3:0] = 1100b$), white LED, and normal-angle incidence of light, unless otherwise specified.

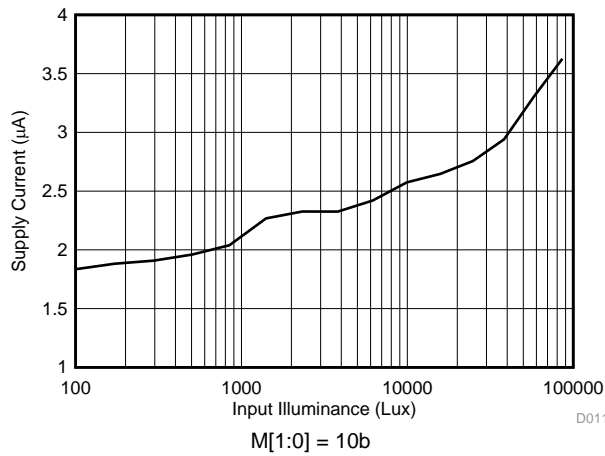

Figure 14. Supply Current vs Input Illuminance

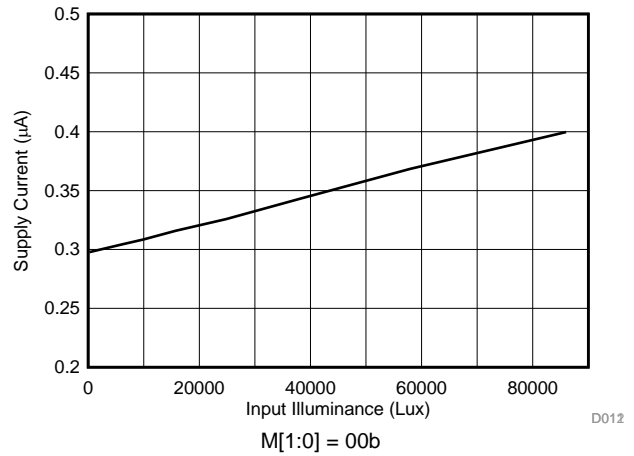

Figure 15. Shutdown Current vs Input Illuminance

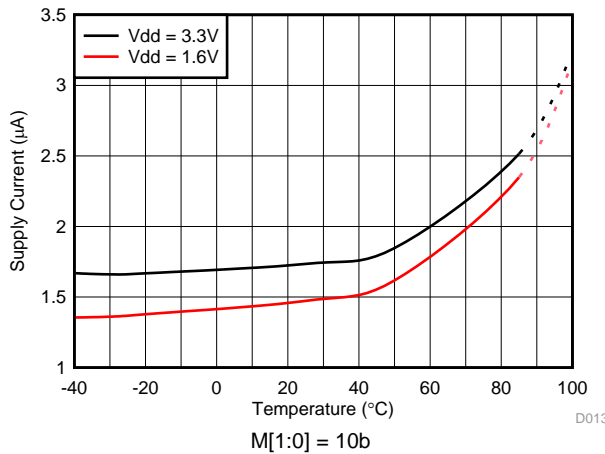

Figure 16. Supply Current vs Temperature

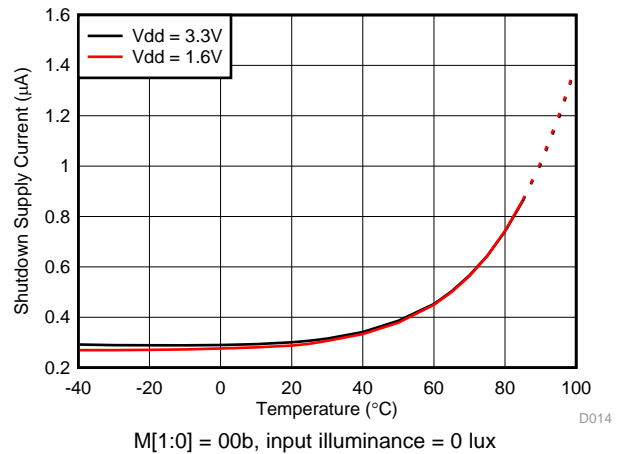
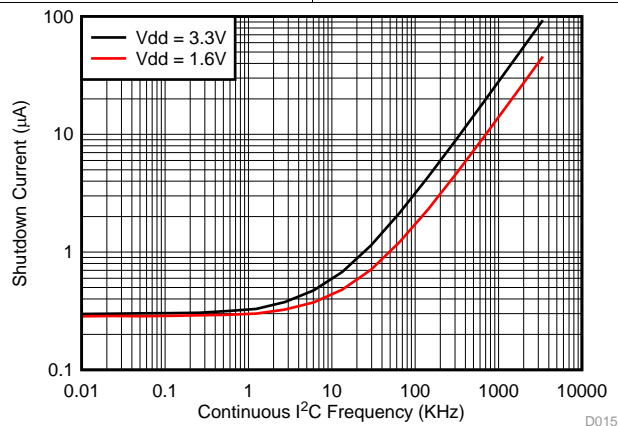

Figure 17. Shutdown Current vs Temperature



Input illuminance = 80 lux, SCL = SDA, continuously toggled at I²C frequency

Note: A typical application runs at a lower duty cycle and thus consumes a lower current.

Figure 18. Supply Current vs Continuous I²C Frequency

7 Detailed Description

7.1 Overview

The OPT3006 measures the ambient light that illuminates the device. This device measures light with a spectral response very closely matched to the human eye, and with very good infrared rejection.

Matching the sensor spectral response to that of the human eye response is vital because ambient light sensors are used to measure and help create ideal human lighting experiences. Strong rejection of infrared light, which a human does not see, is a crucial component of this matching. This matching makes the OPT3006 especially good for operation underneath windows that are visibly dark, but infrared transmissive.

The OPT3006 is fully self-contained to measure the ambient light and report the result in lux digitally over the I²C bus. The result can also be used to alert a system and interrupt a processor with the INT pin. The result can also be summarized with a programmable window comparison and communicated with the INT pin.

The OPT3006 can be configured into an automatic full-scale, range-setting mode that always selects the optimal full-scale range setting for the lighting conditions. This mode frees the user from having to program their software for potential iterative cycles of measurement and readjustment of the full-scale range until optimal for any given measurement. The device can be commanded to operate continuously or in single-shot measurement modes.

The device integrates its result over either 100 ms or 800 ms, so the effects of 50-Hz and 60-Hz noise sources from typical light bulbs are nominally reduced to a minimum.

The device starts up in a low-power shutdown state, such that the OPT3006 only consumes active-operation power after being programmed into an active state.

The OPT3006 optical filtering system is not excessively sensitive to non-ideal particles and micro-shadows on the optical surface. This reduced sensitivity is a result of the relatively minor device dependency on uniform-density optical illumination of the sensor area for infrared rejection. Proper optical surface cleanliness is always recommended for best results on all optical devices.

7.2 Functional Block Diagram

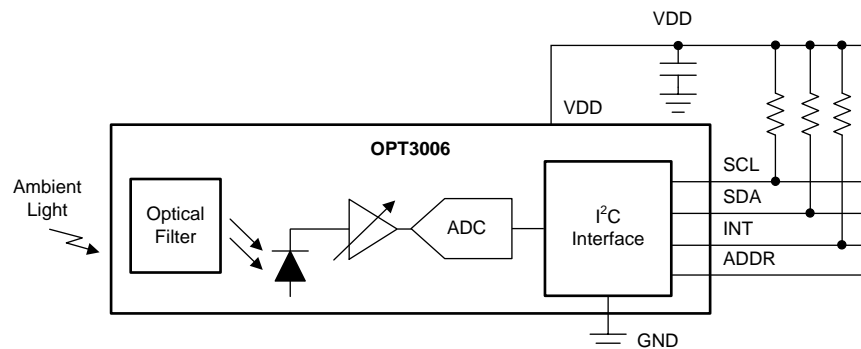

7.3 Feature Description

7.3.1 Human Eye Matching

The OPT3006 spectral response closely matches that of the human eye. If the ambient light sensor measurement is used to help create a good human experience, or create optical conditions that are optimal for a human, the sensor must measure the same spectrum of light that a human sees.

The device also has excellent infrared light (IR) rejection. This IR rejection is especially important because many real-world lighting sources have significant infrared content that humans do not see. If the sensor measures infrared light that the human eye does not see, then a true human experience is not accurately represented.

Furthermore, if the ambient light sensor is hidden underneath a dark window (such that the end-product user cannot see the sensor) the infrared rejection of the OPT3006 becomes significantly more important because many dark windows attenuate visible light but transmit infrared light. This attenuation of visible light and lack of attenuation of IR light amplifies the ratio of the infrared light to visible light that illuminates the sensor. Results can still be well matched to the human eye under this condition because of the high infrared rejection of the OPT3006.

7.3.2 Automatic Full-Scale Range Setting

The OPT3006 has an automatic full-scale range setting feature that eliminates the need to predict and set the optimal range for the device. In this mode, the OPT3006 automatically selects the optimal full-scale range for the given lighting condition. The OPT3006 has a high degree of result matching between the full-scale range settings. This matching eliminates the problem of varying results or the need for range-specific, user-calibrated gain factors when different full-scale ranges are chosen. For further details, see the [Automatic Full-Scale Setting Mode](#) section.

7.3.3 Interrupt Operation, INT Pin, and Interrupt Reporting Mechanisms

The device has an interrupt reporting system that allows the processor connected to the I²C bus to go to sleep, or otherwise ignore the device results, until a user-defined event occurs that requires possible action. Alternatively, this same mechanism can also be used with any system that can take advantage of a single digital signal that indicates whether the light is above or below levels of interest.

The interrupt event conditions are controlled by the high-limit and low-limit registers, as well as the configuration register latch and fault count fields. The results of comparing the result register with the high-limit register and low-limit register are referred to as *fault events*. The fault count register dictates how many consecutive same-result fault events are required to trigger an interrupt event and subsequently change the state of the interrupt reporting mechanisms, which are the INT pin, the flag high field, and the flag low field. The latch field allows a choice between a latched window-style comparison and a transparent hysteresis-style comparison.

The INT pin has an open-drain output, which requires the use of a pull-up resistor. This open-drain output allows multiple devices with open-drain INT pins to be connected to the same line, thus creating a logical *NOR* or *AND* function between the devices. The polarity of the INT pin can be controlled with the polarity of interrupt field in the configuration register. When the POL field is set to 0, the pin operates in an active low behavior that pulls the pin low when the INT pin becomes active. When the POL field is set to 1, the pin operates in an active high behavior and becomes high impedance, thus allowing the pin to go high when the INT pin becomes active.

Additional details of the interrupt reporting registers are described in the [Interrupt Reporting Mechanism Modes](#) and [Internal Registers](#) sections.

Feature Description (continued)

7.3.4 I²C Bus Overview

The OPT3006 offers compatibility with both I²C and SMBus interfaces. The I²C and SMBus protocols are essentially compatible with one another. The I²C interface is used throughout this document as the primary example with the SMBus protocol specified only when a difference between the two protocols is discussed.

The OPT3006 is connected to the bus with two pins: an SCL clock input pin and an SDA open-drain bidirectional data pin. The bus must be controlled by a master device that generates the serial clock (SCL), controls the bus access, and generates start and stop conditions. To address a specific device, the master initiates a start condition by pulling the data signal line (SDA) from a high logic level to a low logic level while SCL is high. All slaves on the bus shift in the slave address byte on the SCL rising edge, with the last bit indicating whether a read or write operation is intended. During the ninth clock pulse, the slave being addressed responds to the master by generating an acknowledge bit by pulling SDA low.

Data transfer is then initiated and eight bits of data are sent, followed by an acknowledge bit. During data transfer, SDA must remain stable while SCL is high. Any change in SDA while SCL is high is interpreted as a start or stop condition. When all data are transferred, the master generates a stop condition, indicated by pulling SDA from low to high while SCL is high. The OPT3006 includes a 28-ms timeout on the I²C interface to prevent locking up the bus. If the SCL line is held low for this duration of time, the bus state machine is reset.

7.3.4.1 Serial Bus Address

To communicate with the OPT3006, the master must first initiate an I²C start command. Then, the master must address slave devices via a slave address byte. The slave address byte consists of seven address bits and a direction bit that indicates whether the action is to be a read or write operation.

Four I²C addresses are possible by connecting the ADDR pin to one of four pins: GND, VDD, SDA, or SCL. [Table 1](#) summarizes the possible addresses with the corresponding ADDR pin configuration. The state of the ADDR pin is sampled on every bus communication and must be driven or connected to the desired level before any activity on the interface occurs.

Table 1. Possible I²C Addresses with Corresponding ADDR Configuration

DEVICE I ² C ADDRESS	ADDR PIN
1000100	GND
1000101	VDD
1000110	SDA
1000111	SCL

7.3.4.2 Serial Interface

The OPT3006 operates as a slave device on both the I²C bus and SMBus. Connections to the bus are made via the SCL clock input line and the SDA open-drain I/O line. The OPT3006 supports the transmission protocol for standard mode (up to 100 kHz), fast mode (up to 400 kHz), and high-speed mode (up to 2.6 MHz). All data bytes are transmitted most-significant bits first.

The SDA and SCL pins feature integrated spike-suppression filters and Schmitt triggers to minimize the effects of input spikes and bus noise. See the [Electrical Interface](#) section for further details of the I²C bus noise immunity.

7.4 Device Functional Modes

7.4.1 Automatic Full-Scale Setting Mode

The OPT3006 has an automatic full-scale-range setting mode that eliminates the need for a user to predict and set the optimal range for the device. This mode is entered when the configuration register range number field (RN[3:0]) is set to 1100b.

The first measurement that the device takes in auto-range mode is a 10-ms range assessment measurement. The device then determines the appropriate full-scale range to take its first full measurement.

For subsequent measurements, the full-scale range is set by the result of the previous measurement. If a measurement is towards the low side of full-scale, the full-scale range is decreased by one or two settings for the next measurement. If a measurement is towards the upper side of full-scale, the full-scale range is increased by one setting for the next measurement.

If the measurement exceeds the full-scale range, resulting from a fast increasing optical transient event, the current measurement is aborted. This invalid measurement is not reported. A 10-ms measurement is taken to assess and properly reset the full-scale range. Then, a new measurement is taken with this proper full-scale range. Therefore, during a fast increasing optical transient in this mode, a measurement can possibly take longer to complete and report than indicated by the configuration register conversion time field (CT).

7.4.2 Interrupt Reporting Mechanism Modes

There are two major types of interrupt reporting mechanism modes: latched window-style comparison mode and transparent hysteresis-style comparison mode. The configuration register latch field (L) (see the [configuration register](#), bit 4) controls which of these two modes is used. An end-of-conversion mode is also associated with each major mode type. The end-of-conversion mode is active when the two most significant bits of the threshold low register are set to 11b. The mechanisms report via the flag high and flag low fields, the conversion ready field, and the INT pin.

7.4.2.1 Latched Window-Style Comparison Mode

The latched window-style comparison mode is typically selected when using the OPT3006 to interrupt an external processor. In this mode, a fault is recognized when the input signal is above the high-limit register or below the low-limit register. When the consecutive fault events trigger the interrupt reporting mechanisms, these mechanisms are latched, thus reporting whether the fault is the result of a high or low comparison. These mechanisms remain latched until the configuration register is read, which clears the INT pin and flag high and flag low fields. The SMBus alert response protocol, described in detail in the [SMBus Alert Response](#) section, clears the pin but does not clear the flag high and flag low fields. The behavior of this mode, along with the conversion ready flag, is summarized in [Table 2](#). Note that [Table 2](#) does not apply when the two threshold low register MSBs (see the [Transparent Hysteresis-Style Comparison Mode](#) section for clarification on the MSBs) are set to 11b.

Device Functional Modes (continued)
Table 2. Latched Window-Style Comparison Mode: Flag Setting and Clearing Summary⁽¹⁾⁽²⁾

OPERATION	FLAG HIGH FIELD	FLAG LOW FIELD	INT PIN ⁽³⁾	CONVERSION READY FIELD
The result register is above the high-limit register for fault count times. See the Result Register and the High-Limit Register for further details.	1	X	Active	1
The result register is below the low-limit register for fault count times. See the Result Register and the Low-Limit Register for further details.	X	1	Active	1
The conversion is complete with fault count criterion not met	X	X	X	1
Configuration register read ⁽⁴⁾	0	0	Inactive	0
Configuration register write, M[1:0] = 00b (shutdown)	X	X	X	X
Configuration register write, M[1:0] > 00b (not shutdown)	X	X	X	0
SMBus alert response protocol	X	X	Inactive	X

- (1) X = no change from the previous state.
- (2) The high-limit register is assumed to be greater than the low-limit register. If this assumption is incorrect, the flag high field and flag low field can take on different behaviors.
- (3) The INT pin depends on the setting of the polarity field (POL). The INT pin is low when the pin state is active and POL = 0 (active low) or when the pin state is inactive and POL = 1 (active high).
- (4) Immediately after the configuration register is read, the device automatically resets the conversion ready field to its 0 state. Thus, if two configuration register reads are performed immediately after a conversion completion, the first reads 1 and the second reads 0.

7.4.2.2 Transparent Hysteresis-Style Comparison Mode

The transparent hysteresis-style comparison mode is typically used when a single digital signal is desired that indicates whether the input light is higher than or lower than a light level of interest. If the result register is higher than the high-limit register for a consecutive number of events set by the fault count field, the INT line is set to active, the flag high field is set to 1, and the flag low field is set to 0. If the result register is lower than the low-limit register for a consecutive number of events set by the fault count field, the INT line is set to inactive, the flag low field is set to 1, and the flag high field is set to 0. The INT pin and flag high and flag low fields do not change state with configuration reads and writes. The INT pin and flag fields continually report the appropriate comparison of the light to the low-limit and high-limit registers. The device does not respond to the SMBus alert response protocol while in either of the two transparent comparison modes (configuration register, latch field = 0). The behavior of this mode, along with the conversion ready is summarized in [Table 3](#). Note that [Table 3](#) does not apply when the two threshold low register MSBs (LE[3:2] from [Table 11](#)) are set to 11.

Table 3. Transparent Hysteresis-Style Comparison Mode: Flag Setting and Clearing Summary⁽¹⁾⁽²⁾

OPERATION	FLAG HIGH FIELD	FLAG LOW FIELD	INT PIN ⁽³⁾	CONVERSION READY FIELD
The result register is above the high-limit register for fault count times. See the Result Register and the High-Limit Register for further details.	1	0	Active	1
The result register is below the low-limit register for fault count times. See the Result Register and the Low-Limit Register for further details.	0	1	Inactive	1
The conversion is complete with fault count criterion not met	X	X	X	1
Configuration register read ⁽⁴⁾	X	X	X	0
Configuration register write, M[1:0] = 00b (shutdown)	X	X	X	X
Configuration register write, M[1:0] > 00b (not shutdown)	X	X	X	0
SMBus alert response protocol	X	X	X	X

- (1) X = no change from the previous state.
- (2) The high-limit register is assumed to be greater than the low-limit register. If this assumption is incorrect, the flag high field and flag low field can take on different behaviors.
- (3) The INT pin depends on the setting of the polarity field (POL). The INT pin is low when the pin state is active and POL = 0 (active low) or when the pin state is inactive and POL = 1 (active high).
- (4) Immediately after the configuration register is read, the device automatically resets the conversion ready field to its 0 state. Thus, if two configuration register reads are performed immediately after a conversion completion, the first reads 1 and the second reads 0.

7.4.2.3 End-of-Conversion Mode

An end-of-conversion indicator mode can be used when every measurement is desired to be read by the processor, prompted by the INT pin going active on every measurement completion. This mode is entered by setting the most significant two bits of the low-limit register (LE[3:2] from the [Low-Limit Register](#)) to 11b. This end-of-conversion mode is typically used in conjunction with the latched window-style comparison mode. The INT pin becomes inactive when the configuration register is read or the configuration register is written with a non-shutdown parameter or in response to an SMBus alert response. [Table 4](#) summarizes the interrupt reporting mechanisms as a result of various operations.

Table 4. End-of-Conversion Mode while in Latched Window-Style Comparison Mode: Flag Setting and Clearing Summary⁽¹⁾

OPERATION	FLAG HIGH FIELD	FLAG LOW FIELD	INT PIN ⁽²⁾	CONVERSION READY FIELD
The result register is above the high-limit register for fault count times. See the Result Register and the High-Limit Register for further details.	1	X	Active	1
The result register is below the low-limit register for fault count times. See the Result Register and the Low-Limit Register for further details.	X	1	Active	1
The conversion is complete with fault count criterion not met	X	X	Active	1
Configuration register read ⁽³⁾	0	0	Inactive	0
Configuration register write, M[1:0] = 00b (shutdown)	X	X	X	X
Configuration register write, M[1:0] > 00b (not shutdown)	X	X	X	0
SMBus alert response protocol	X	X	Inactive	X

(1) X = no change from the previous state.

(2) The INT pin depends on the setting of the polarity field (POL). The INT pin is low when the pin state is active and POL = 0 (active low) or when the pin state is inactive and POL = 1 (active high).

(3) Immediately after the configuration register is read, the device automatically resets the conversion ready field to its 0 state. Thus, if two configuration register reads are performed immediately after a conversion completion, the first reads 1 and the second reads 0.

Note that when transitioning from end-of-conversion mode to the standard comparison modes (that is, programming LE[3:2] from 11b to 00b) while the configuration register latch field (L) is 1, a subsequent write to the configuration register latch field (L) to 0 is necessary in order to properly clear the INT pin. The latch field can then be set back to 1 if desired.

7.4.2.4 End-of-Conversion and Transparent Hysteresis-Style Comparison Mode

The combination of end-of-conversion mode and transparent hysteresis-style comparison mode can also be programmed simultaneously. The behavior of this combination is shown in [Table 5](#).

Table 5. End-Of-Conversion Mode while in Transparent Hysteresis-Style Comparison Mode: Flag Setting and Clearing Summary⁽¹⁾

OPERATION	FLAG HIGH FIELD	FLAG LOW FIELD	INT PIN ⁽²⁾	CONVERSION READY FIELD
The result register is above the high-limit register for fault count times. See the Result Register and the High-Limit Register for further details.	1	0	Active	1
The result register is below the low-limit register for fault count times. See the Result Register and the Low-Limit Register for further details.	0	1	Active	1
The conversion is complete with fault count criterion not met	X	X	Active	1
Configuration register read ⁽³⁾	X	X	Inactive	0
Configuration register write, M[1:0] = 00b (shutdown)	X	X	X	X
Configuration register write, M[1:0] > 00b (not shutdown)	X	X	Inactive	0
SMBus alert response protocol	X	X	X	X

(1) X = no change from the previous state.

(2) The INT pin depends on the setting of the polarity field (POL). The INT pin is low when the pin state is active and POL = 0 (active low) or when the pin state is inactive and POL = 1 (active high).

(3) Immediately after the configuration register is read, the device automatically resets the conversion ready field to its 0 state. Thus, if two configuration register reads are performed immediately after a conversion completion, the first reads 1 and the second reads 0.

7.5 Programming

The OPT3006 supports the transmission protocol for standard mode (up to 100 kHz), fast mode (up to 400 kHz), and high-speed mode (up to 2.6 MHz). Fast and standard modes are described as the default protocol, referred to as *F/S*. High-speed mode is described in the [High-Speed I²C Mode](#) section.

7.5.1 Writing and Reading

Accessing a specific register on the OPT3006 is accomplished by writing the appropriate register address during the I²C transaction sequence. Refer to [Table 6](#) for a complete list of registers and their corresponding register addresses. The value for the register address (as shown in [Figure 19](#)) is the first byte transferred after the slave address byte with the R/W bit low.

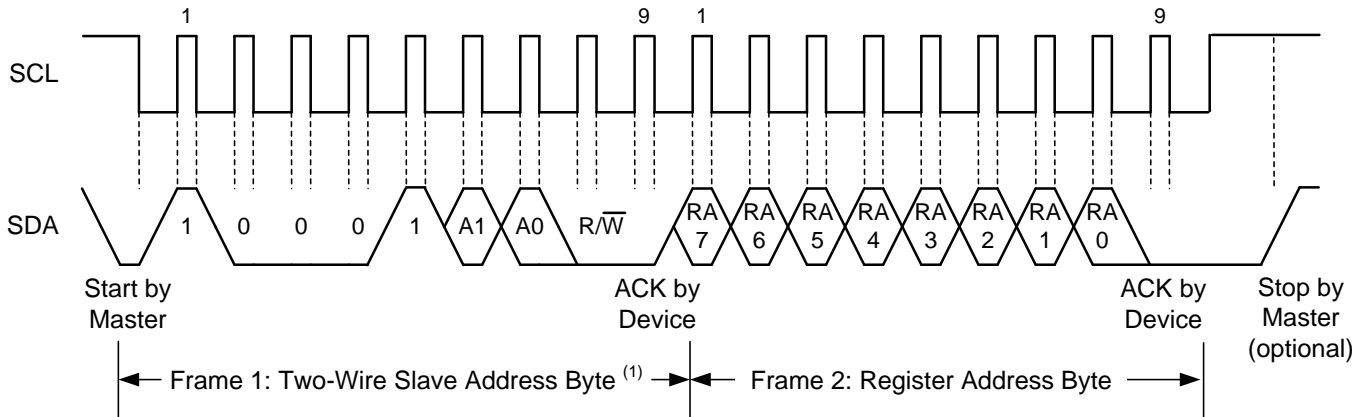

(1) The value of the slave address byte is determined by the ADDR pin setting; see [Table 1](#).

Figure 19. Setting the I²C Register Address

Writing to a register begins with the first byte transmitted by the master. This byte is the slave address with the R/W bit low. The OPT3006 then acknowledges receipt of a valid address. The next byte transmitted by the master is the address of the register that data are to be written to. The next two bytes are written to the register addressed by the register address. The OPT3006 acknowledges receipt of each data byte. The master may terminate the data transfer by generating a start or stop condition.

When reading from the OPT3006, the last value stored in the register address by a write operation determines which register is read during a read operation. To change the register address for a read operation, a new partial I²C write transaction must be initiated. This partial write is accomplished by issuing a slave address byte with the R/W bit low, followed by the register address byte and a stop command. The master then generates a start condition and sends the slave address byte with the R/W bit high to initiate the read command. The next byte is transmitted by the slave and is the most significant byte of the register indicated by the register address. This byte is followed by an acknowledge from the master; then the slave transmits the least significant byte. The master acknowledges receipt of the data byte. The master may terminate the data transfer by generating a not-acknowledge after receiving any data byte, or by generating a start or stop condition. If repeated reads from the same register are desired, continually sending the register address bytes is not necessary; the OPT3006 retains the register address until that number is changed by the next write operation.

Programming (continued)

Figure 20 and Figure 21 show the write and read operation timing diagrams, respectively. Note that register bytes are sent most significant byte first, followed by the least significant byte.

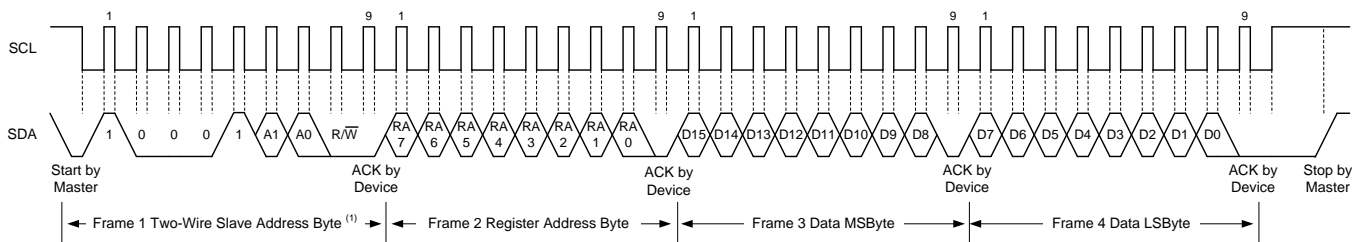

(1) The value of the slave address byte is determined by the setting of the ADDR pin; see Table 1.

Figure 20. I²C Write Example

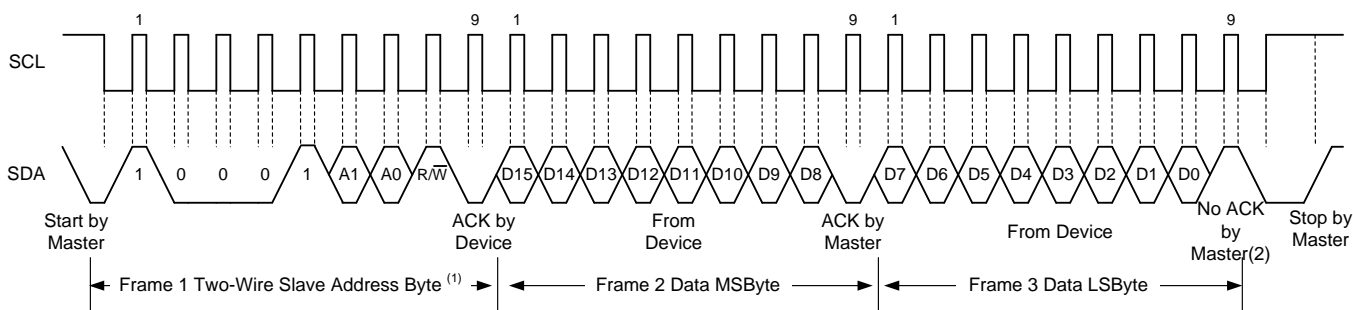

(1) The value of the slave address byte is determined by the ADDR pin setting; see Table 1.

(2) An ACK by the master can also be sent.

Figure 21. I²C Read Example

7.5.1.1 High-Speed I²C Mode

When the bus is idle, both the SDA and SCL lines are pulled high by the pull-up resistors or active pull-up devices. The master generates a start condition followed by a valid serial byte containing the high-speed (HS) master code 0000 1XXXb. This transmission is made in either standard mode or fast mode (up to 400 kHz). The OPT3006 does not acknowledge the HS master code but does recognize the code and switches its internal filters to support a 2.6-MHz operation.

The master then generates a repeated start condition (a repeated start condition has the same timing as the start condition). After this repeated start condition, the protocol is the same as F/S mode, except that transmission speeds up to 2.6 MHz are allowed. Instead of using a stop condition, use repeated start conditions to secure the bus in HS mode. A stop condition ends the HS mode and switches all internal filters of the OPT3006 to support the F/S mode.

7.5.1.2 General-Call Reset Command

The I²C general-call reset allows the host controller in one command to reset all devices on the bus that respond to the general-call reset command. The general call is initiated by writing to the I²C address 0 (0000 0000b). The reset command is initiated when the subsequent second address byte is 06h (0000 0110b). With this transaction, the device issues an acknowledge bit and sets all of its registers to the power-on-reset default condition.

Programming (continued)

7.5.1.3 SMBus Alert Response

The SMBus alert response provides a quick identification for which device issued the interrupt. Without this alert response capability, the processor does not know which device pulled the interrupt line when there are multiple slave devices connected.

The OPT3006 is designed to respond to the SMBus alert response address, when in the latched window-style comparison mode (configuration register, latch field = 1). The OPT3006 does not respond to the SMBus alert response when in transparent mode (configuration register, latch field = 0).

The response behavior of the OPT3006 to the SMBus alert response is shown in [Figure 22](#). When the interrupt line to the processor is pulled to active, the master can broadcast the alert response slave address (0001 1001b). Following this alert response, any slave devices that generated an alert identify themselves by acknowledging the alert response and sending their respective I²C address on the bus. The alert response can activate several different slave devices simultaneously. If more than one slave attempts to respond, bus arbitration rules apply. The device with the lowest address wins the arbitration. If the OPT3006 loses the arbitration, the device does not acknowledge the I²C transaction and its INT pin remains in an active state, prompting the I²C master processor to issue a subsequent SMBus alert response. When the OPT3006 wins the arbitration, the device acknowledges the transaction and sets its INT pin to inactive. The master can issue that same command again, as many times as necessary to clear the INT pin. See the [Interrupt Reporting Mechanism Modes](#) section for additional details of how the flags and INT pin are controlled. The master can obtain information about the source of the OPT3006 interrupt from the address broadcast in the above process. The flag high field (configuration register, bit 6) is sent as the final LSB of the address to provide the master additional information about the cause of the OPT3006 interrupt. If the master requires additional information, the result register or the configuration register can be queried. The flag high and flag low fields are not cleared upon an SMBus alert response.

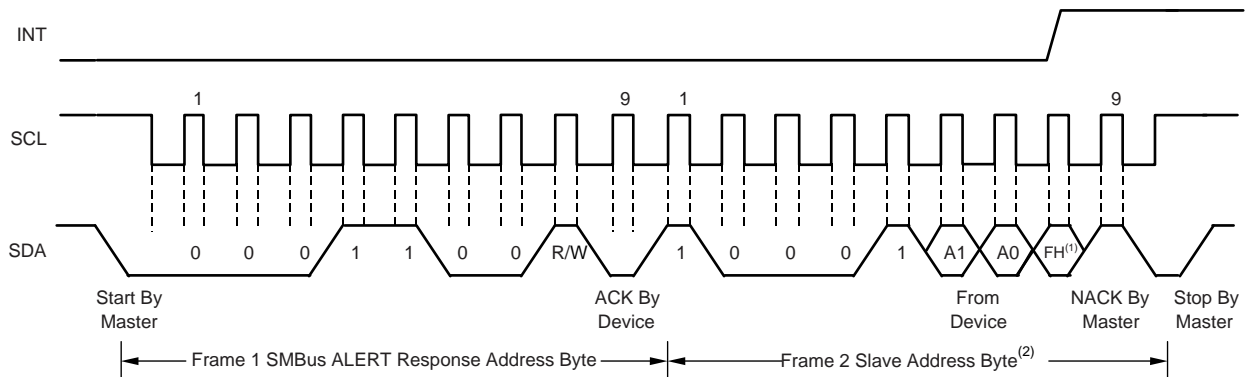

(1) FH is the flag high field (FH) in the configuration register (see [Table 10](#)).

(2) A1 and A0 are determined by the ADDR pin; see [Table 1](#).

Figure 22. Timing Diagram for SMBus Alert Response

7.6 Register Maps

7.6.1 Internal Registers

The device is operated over the I²C bus with registers that contain configuration, status, and result information. All registers are 16 bits long.

There are four main registers: result, configuration, low-limit, and high-limit. There are also two ID registers: manufacturer ID and device ID. [Table 6](#) lists these registers.

Table 6. Register Map

REGISTER	ADDRESS (Hex) ⁽¹⁾	BIT 15	BIT 14	BIT 13	BIT 12	BIT 11	BIT 10	BIT 9	BIT 8	BIT 7	BIT 6	BIT 5	BIT 4	BIT 3	BIT 2	BIT 1	BIT 0
Result	00h	E3	E2	E1	E0	R11	R10	R9	R8	R7	R6	R5	R4	R3	R2	R1	R0
Configuration	01h	RN3	RN2	RN1	RN0	CT	M1	M0	OVF	CRF	FH	FL	L	POL	ME	FC1	FC0
Low Limit	02h	LE3	LE2	LE1	LE0	TL11	TL10	TL9	TL8	TL7	TL6	TL5	TL4	TL3	TL2	TL1	TL0
High Limit	03h	HE3	HE2	HE1	HE0	TH11	TH10	TH9	TH8	TH7	TH6	TH5	TH4	TH3	TH2	TH1	TH0
Manufacturer ID	7Eh	ID15	ID14	ID13	ID12	ID11	ID10	ID9	ID8	ID7	ID6	ID5	ID4	ID3	ID2	ID1	ID0
Device ID	7Fh	DID15	DID14	DID13	DID12	DID11	DID10	DID9	DID8	DID7	DID6	DID5	DID4	DID3	DID2	DID1	DID0

(1) Register offset and register address are used interchangeably.

7.6.1.1 Register Descriptions
NOTE

Register offset and register address are used interchangeably.

7.6.1.1.1 Result Register (offset = 00h)

This register contains the result of the most recent light to digital conversion. This 16-bit register has two fields: a 4-bit exponent and a 12-bit mantissa.

Figure 23. Result Register (Read-Only)

15	14	13	12	11	10	9	8
E3	E2	E1	E0	R11	R10	R9	R8
R	R	R	R	R	R	R	R
7	6	5	4	3	2	1	0
R7	R6	R5	R4	R3	R2	R1	R0
R	R	R	R	R	R	R	R

LEGEND: R = Read only

Table 7. Result Register Field Descriptions

Bit	Field	Type	Reset	Description
15:12	E[3:0]	R	0h	Exponent. These bits are the exponent bits. Table 8 provides further details.
11:0	R[11:0]	R	000h	Fractional result. These bits are the result in straight binary coding (zero to full-scale).

Table 8. Full-Scale Range and LSB Size as a Function of Exponent Level

E3	E2	E1	E0	FULL-SCALE RANGE (lux)	LSB SIZE (lux per LSB)
0	0	0	0	40.95	0.01
0	0	0	1	81.90	0.02
0	0	1	0	163.80	0.04
0	0	1	1	327.60	0.08
0	1	0	0	655.20	0.16
0	1	0	1	1310.40	0.32
0	1	1	0	2620.80	0.64
0	1	1	1	5241.60	1.28
1	0	0	0	10483.20	2.56
1	0	0	1	20966.40	5.12
1	0	1	0	41932.80	10.24
1	0	1	1	83865.60	20.48

 The formula to translate this register into lux is given in [Equation 1](#):

$$\text{lux} = \text{LSB_Size} \times \text{R}[11:0] \quad (1)$$

where:

$$\text{LSB_Size} = 0.01 \times 2^{\text{E}[3:0]} \quad (2)$$

 LSB_Size can also be taken from [Table 8](#). The complete lux equation is shown in [Equation 3](#):

$$\text{lux} = 0.01 \times (2^{\text{E}[3:0]}) \times \text{R}[11:0] \quad (3)$$

 A series of result register output examples with the corresponding LSB weight and resulting lux are given in [Table 9](#). Note that many combinations of exponents (E[3:0]) and fractional results (R[11:0]) can map onto the same lux result, as shown in the examples of [Table 9](#).

Table 9. Examples of Decoding the Result Register into lux

RESULT REGISTER (Bits 15:0, Binary)	EXPONENT (E[3:0], Hex)	FRACTIONAL RESULT (R[11:0], Hex)	LSB WEIGHT (lux, Decimal)	RESULTING LUX (Decimal)
0000 0000 0000 0001b	00h	001h	0.01	0.01
0000 1111 1111 1111b	00h	FFFh	0.01	40.95
0011 0100 0101 0110b	03h	456h	0.08	88.80
0111 1000 1001 1010b	07h	89Ah	1.28	2818.56
1000 1000 0000 0000b	08h	800h	2.56	5242.88
1001 0100 0000 0000b	09h	400h	5.12	5242.88
1010 0010 0000 0000b	0Ah	200h	10.24	5242.88
1011 0001 0000 0000b	0Bh	100h	20.48	5242.88
1011 0000 0000 0001b	0Bh	001h	20.48	20.48
1011 1111 1111 1111b	0Bh	FFFh	20.48	83865.60

Note that the exponent field can be disabled (set to zero) by enabling the exponent mask (configuration register, ME field = 1) and manually programming the full-scale range (configuration register, RN[3:0] < 1100b (0Ch)), allowing for simpler operation in a manually-programmed, full-scale mode. Calculating lux from the result register contents only requires multiplying the result register by the LSB weight (in lux) associated with the specific programmed full-scale range (see [Table 8](#)). See the [Low-Limit Register](#) for details.

See the configuration register conversion time field (CT, bit 11) description for more information on lux resolution as a function of conversion time.

7.6.1.1.2 Configuration Register (offset = 01h) [reset = C810h]

This register controls the major operational modes of the device. This register has 11 fields, which are documented below. If a measurement conversion is in progress when the configuration register is written, the active measurement conversion immediately aborts. If the new configuration register directs a new conversion, that conversion is subsequently started.

Figure 24. Configuration Register

15	14	13	12	11	10	9	8
RN3	RN2	RN1	RN0	CT	M1	M0	OVF
R/W	R/W	R/W	R/W	R/W	R/W	R/W	R
7	6	5	4	3	2	1	0
CRF	FH	FL	L	POL	ME	FC1	FC0
R	R	R	R/W	R/W	R/W	R/W	R/W

LEGEND: R/W = Read/Write; R = Read only

Table 10. Configuration Register Field Descriptions

Bit	Field	Type	Reset	Description
15:12	RN[3:0]	R/W	1100b	Range number field (read or write). The range number field selects the full-scale lux range of the device. The format of this field is the same as the result register exponent field (E[3:0]); see Table 8 . When RN[3:0] is set to 1100b (0Ch), the device operates in automatic full-scale setting mode, as described in the Automatic Full-Scale Setting Mode section. In this mode, the automatically chosen range is reported in the result exponent (register 00h, E[3:0]). The device powers up as 1100 in automatic full-scale setting mode. Codes 1101b, 1110b, and 1111b (0Dh, 0Eh, and 0Fh) are reserved for future use.

Table 10. Configuration Register Field Descriptions (continued)

Bit	Field	Type	Reset	Description
11	CT	R/W	1b	<p>Conversion time field (read or write). The conversion time field determines the length of the light to digital conversion process. The choices are 100 ms and 800 ms. A longer integration time allows for a lower noise measurement. The conversion time also relates to the effective resolution of the data conversion process. The 800-ms conversion time allows for the fully specified lux resolution. The 100-ms conversion time with full-scale ranges above 0101b for E[3:0] in the result and configuration registers also allows for the fully specified lux resolution. The 100-ms conversion time with full-scale ranges below and including 0101b for E[3:0] can reduce the effective result resolution by up to three bits, as a function of the selected full-scale range. Range 0101b reduces by one bit. Ranges 0100b, 0011b, 0010b, and 0001b reduces by two bits. Range 0000b reduces by three bits. The result register format and associated LSB weight does not change as a function of the conversion time. 0 = 100 ms 1 = 800 ms</p>
10:9	M[1:0]	R/W	00b	<p>Mode of conversion operation field (read or write). The mode of conversion operation field controls whether the device is operating in continuous conversion, single-shot, or low-power shutdown mode. The default is 00b (shutdown mode), such that upon power-up, the device only consumes operational level power after appropriately programming the device. When single-shot mode is selected by writing 01b to this field, the field continues to read 01b while the device is actively converting. When the single-shot conversion is complete, the mode of conversion operation field is automatically set to 00b and the device is shut down. When the device enters shutdown mode, either by completing a single-shot conversion or by a manual write to the configuration register, there is no change to the state of the reporting flags (conversion ready, flag high, flag low) or the INT pin. These signals are retained for subsequent read operations while the device is in shutdown mode. 00 = Shutdown (default) 01 = Single-shot 10, 11 = Continuous conversions</p>
8	OVF	R	0b	<p>Overflow flag field (read-only). The overflow flag field indicates when an overflow condition occurs in the data conversion process, typically because the light illuminating the device exceeds the programmed full-scale range of the device. Under this condition OVF is set to 1, otherwise OVF remains at 0. The field is reevaluated on every measurement. If the full-scale range is manually set (RN[3:0] field < 1100b), the overflow flag field can be set while the result register reports a value less than full-scale. This result occurs if the input light has a temporary high spike level that temporarily overloads the integrating ADC converter circuitry but returns to a level within range before the conversion is complete. Thus, the overflow flag reports a possible error in the conversion process. This behavior is common to integrating-style converters. If the full-scale range is automatically set (RN[3:0] field = 1100b), the only condition that sets the overflow flag field is if the input light is beyond the full-scale level of the entire device. When there is an overflow condition and the full-scale range is not at maximum, the OPT3006 aborts its current conversion, sets the full-scale range to a higher level, and starts a new conversion. The flag is set at the end of the process. This process repeats until there is either no overflow condition or until the full-scale range is set to its maximum range.</p>
7	CRF	R	0b	<p>Conversion ready field (read-only). The conversion ready field indicates when a conversion completes. The field is set to 1 at the end of a conversion and is cleared (set to 0) when the configuration register is subsequently read or written with any value except one containing the shutdown mode (mode of operation field, M[1:0] = 00b). Writing a shutdown mode does not affect the state of this field; see the Interrupt Reporting Mechanism Modes section for more details.</p>
6	FH	R	0b	<p>Flag high field (read-only). The flag high field (FH) identifies that the result of a conversion is larger than a specified level of interest. FH is set to 1 when the result is larger than the level in the high-limit register (register address 03h) for a consecutive number of measurements defined by the fault count field (FC[1:0]). See the Interrupt Reporting Mechanism Modes section for more details on clearing and other behaviors of this field.</p>
5	FL	R	0b	<p>Flag low field (read-only). The flag low field (FL) identifies that the result of a conversion is smaller than a specified level of interest. FL is set to 1 when the result is smaller than the level in the low-limit register (register address 02h) for a consecutive number of measurements defined by the fault count field (FC[1:0]). See the Interrupt Reporting Mechanism Modes section for more details on clearing and other behaviors of this field.</p>

Table 10. Configuration Register Field Descriptions (continued)

Bit	Field	Type	Reset	Description
4	L	R/W	1b	<p>Latch field (read or write). The latch field controls the functionality of the interrupt reporting mechanisms: the INT pin, the flag high field (FH), and flag low field (FL). This bit selects the reporting style between a latched window-style comparison and a transparent hysteresis-style comparison. 0 = The device functions in transparent hysteresis-style comparison operation, where the three interrupt reporting mechanisms directly reflect the comparison of the result register with the high- and low-limit registers with no user-controlled clearing event. See the Interrupt Operation, INT Pin, and Interrupt Reporting Mechanisms section for further details. 1 = The device functions in latched window-style comparison operation, latching the interrupt reporting mechanisms until a user-controlled clearing event.</p>
3	POL	R/W	0b	<p>Polarity field (read or write). The polarity field controls the polarity or active state of the INT pin. 0 = The INT pin reports active low, pulling the pin low upon an interrupt event. 1 = Operation of the INT pin is inverted, where the INT pin reports active high, becoming high impedance and allowing the INT pin to be pulled high upon an interrupt event.</p>
2	ME	R/W	0b	<p>Mask exponent field (read or write). The mask exponent field forces the result register exponent field (register 00h, bits E[3:0]) to 0000b when the full-scale range is manually set, which can simplify the processing of the result register when the full-scale range is manually programmed. This behavior occurs when the mask exponent field is set to 1 and the range number field (RN[3:0]) is set to less than 1100b. Note that the masking is only performed to the result register. When using the interrupt reporting mechanisms, the result comparison with the low-limit and high-limit registers is unaffected by the ME field.</p>
1:0	FC[1:0]	R/W	00b	<p>Fault count field (read or write). The fault count field instructs the device as to how many consecutive fault events are required to trigger the interrupt reporting mechanisms: the INT pin, the flag high field (FH), and flag low field (FL). The fault events are described in the latch field (L), flag high field (FH), and flag low field (FL) descriptions. 00 = One fault count (default) 01 = Two fault counts 10 = Four fault counts 11 = Eight fault counts</p>

7.6.1.1.3 Low-Limit Register (offset = 02h) [reset = C000h]

This register sets the lower comparison limit for the interrupt reporting mechanisms: the INT pin, the flag high field (FH), and flag low field (FL), as described in the [Interrupt Reporting Mechanism Modes](#) section.

Figure 25. Low-Limit Register

15	14	13	12	11	10	9	8
LE3	LE2	LE1	LE0	TL11	TL10	TL9	TL8
R/W	R/W	R/W	R/W	R/W	R/W	R/W	R/W
7	6	5	4	3	2	1	0
TL7	TL6	TL5	TL4	TL3	TL2	TL1	TL0
R/W	R/W	R/W	R/W	R/W	R/W	R/W	R/W

LEGEND: R/W = Read/Write

Table 11. Low-Limit Register Field Descriptions

Bit	Field	Type	Reset	Description
15:12	LE[3:0]	R/W	0h	Exponent. These bits are the exponent bits. Table 12 provides further details.
11:0	TL[11:0]	R/W	000h	Result. These bits are the result in straight binary coding (zero to full-scale).

The format of this register is nearly identical to the format of the result register described in the [Result Register](#). The low-limit register exponent (LE[3:0]) is similar to the result register exponent (E[3:0]). The low-limit register result (TL[11:0]) is similar to result register result (R[11:0]).

The equation to translate this register into the lux threshold is given in [Equation 4](#), which is similar to the equation for the result register, [Equation 3](#).

$$\text{lux} = 0.01 \times (2^{\text{LE}[3:0]}) \times \text{TL}[11:0] \quad (4)$$

[Table 12](#) gives the full-scale range and LSB size as it applies to the low-limit register. The detailed discussion and examples given in for the [Result Register](#) apply to the low-limit register as well.

Table 12. Full-Scale Range and LSB Size as a Function of Exponent Level

LE3	LE2	LE1	LE0	FULL-SCALE RANGE (lux)	LSB SIZE (lux per LSB)
0	0	0	0	40.95	0.01
0	0	0	1	81.90	0.02
0	0	1	0	163.80	0.04
0	0	1	1	327.60	0.08
0	1	0	0	655.20	0.16
0	1	0	1	1310.40	0.32
0	1	1	0	2620.80	0.64
0	1	1	1	5241.60	1.28
1	0	0	0	10483.20	2.56
1	0	0	1	20966.40	5.12
1	0	1	0	41932.80	10.24
1	0	1	1	83865.60	20.48

NOTE

The result and limit registers are all converted to lux values internally for comparison. These registers can have different exponent fields. However, when using a manually-set full-scale range (configuration register, RN < 0Ch, with mask enable (ME) active), programming the manually-set full-scale range into the LE[3:0] and HE[3:0] fields can simplify the choice of programming the register. This simplification results in the user only having to think about the fractional result and not the exponent part of the result.

7.6.1.1.4 High-Limit Register (offset = 03h) [reset = BFFFh]

The high-limit register sets the upper comparison limit for the interrupt reporting mechanisms: the INT pin, the flag high field (FH), and flag low field (FL), as described in the [Interrupt Operation, INT Pin, and Interrupt Reporting Mechanisms](#) section. The format of this register is almost identical to the format of the low-limit register (described in the [Low-Limit Register](#)) and the result register (described in the [Result Register](#)). To explain the similarity in more detail, the high-limit register exponent (HE[3:0]) is similar to the low-limit register exponent (LE[3:0]) and the result register exponent (E[3:0]). The high-limit register result (TH[11:0]) is similar to the low-limit result (TH[11:0]) and the result register result (R[11:0]). Note that the comparison of the high-limit register with the result register is unaffected by the ME bit.

When using a manually-set, full-scale range with the mask enable (ME) active, programming the manually-set, full-scale range into the HE[3:0] bits can simplify the choice of values required to program into this register. The formula to translate this register into lux is similar to [Equation 4](#). The full-scale values are similar to [Table 8](#).

Figure 26. High-Limit Register

15		14		13		12		11		10		9		8	
HE3		HE2		HE1		HE0		TH11		TH10		TH9		TH8	
R/W		R/W		R/W		R/W		R/W		R/W		R/W		R/W	
7		6		5		4		3		2		1		0	
TH7		TH6		TH5		TH4		TH3		TH2		TH1		TH0	
R/W		R/W		R/W		R/W		R/W		R/W		R/W		R/W	

LEGEND: R/W = Read/Write

Table 13. High-Limit Register Field Descriptions

Bit	Field	Type	Reset	Description
15:12	HE[3:0]	R/W	Bh	Exponent. These bits are the exponent bits.
11:0	TH[11:0]	R/W	FFFh	Result. These bits are the result in straight binary coding (zero to full-scale).

7.6.1.1.5 Manufacturer ID Register (offset = 7Eh) [reset = 5449h]

This register is intended to help uniquely identify the device.

Figure 27. Manufacturer ID Register

15	14	13	12	11	10	9	8
ID15	ID14	ID13	ID12	ID11	ID10	ID9	ID8
R	R	R	R	R	R	R	R
7	6	5	4	3	2	1	0
ID7	ID6	ID5	ID4	ID3	ID2	ID1	ID0
R	R	R	R	R	R	R	R

LEGEND: R = Read only

Table 14. Manufacturer ID Register Field Descriptions

Bit	Field	Type	Reset	Description
15:0	ID[15:0]	R	5449h	Manufacturer ID. The manufacturer ID reads 5449h. In ASCII code, this register reads <i>TI</i> .

7.6.1.1.6 Device ID Register (offset = 7Fh) [reset = 3001h]

This register is also intended to help uniquely identify the device.

Figure 28. Device ID Register

15	14	13	12	11	10	9	8
DID15	DID14	DID13	DID12	DID11	DID10	DID9	DID8
R	R	R	R	R	R	R	R
7	6	5	4	3	2	1	0
DID7	DID6	DID5	DID4	DID3	DID2	DID1	DID0
R	R	R	R	R	R	R	R

LEGEND: R = Read only

Table 15. Device ID Register Field Descriptions

Bit	Field	Type	Reset	Description
15:0	DID[15:0]	R	3001h	Device ID. The device ID reads 3001h.

8 Application and Implementation

NOTE

Information in the following applications sections is not part of the TI component specification, and TI does not warrant its accuracy or completeness. TI's customers are responsible for determining suitability of components for their purposes. Customers should validate and test their design implementation to confirm system functionality.

8.1 Application Information

Ambient light sensors are used in a wide variety of applications that require control as a function of ambient light. Because ambient light sensors nominally match the human eye spectral response, they are superior to photodiodes when the goal is to create an experience for human beings. Very common applications include display optical-intensity control and industrial or home lighting control.

There are two categories of interface to the OPT3006: electrical and optical.

8.1.1 Electrical Interface

The electrical interface is quite simple, as illustrated in [Figure 29](#). Connect the OPT3006 I²C SDA and SCL pins to the same pins of an applications processor, microcontroller, or other digital processor. If that digital processor requires an interrupt resulting from an event of interest from the OPT3006, then connect the INT pin to either an interrupt or general-purpose I/O pin of the processor. There are multiple uses for this interrupt, including signaling the system to wake up from low-power mode, processing other tasks while waiting for an ambient light event of interest, or alerting the processor that a sample is ready to be read. Connect pullup resistors between a power supply appropriate for digital communication and the SDA and SCL pins (because they have open-drain output structures). If the INT pin is used, connect a pullup resistor to the INT pin. A typical value for these pullup resistors is 10 k Ω . The resistor choice can be optimized in conjunction to the bus capacitance to balance the system speed, power, noise immunity, and other requirements.

The power supply and grounding considerations are discussed in the [Power-Supply Recommendations](#) section.

Although spike suppression is integrated in the SDA and SCL pin circuits, use proper layout practices to minimize the amount of coupling into the communication lines. One possible introduction of noise occurs from capacitively coupling signal edges between the two communication lines themselves. Another possible noise introduction comes from other switching noise sources present in the system, especially for long communication lines. In noisy environments, shield communication lines to reduce the possibility of unintended noise coupling into the digital I/O lines that could be incorrectly interpreted.

8.1.2 Optical Interface

The optical interface is physically located on the same side of the device as the electrical interface, as shown in the *Sensing Area* of the mechanical packages at the end of this data sheet. At a system level, this configuration requires that the light that illuminates the sensor must come through the PCB or FPCB. Typically, the best solution is to create a cutout area in the PCB. Other solutions are possible, but with associated design trade-offs. This cutout must be carefully designed because the dimensions and tolerances impact the net-system, optical field-of-view performance. The design of this cutout is discussed more in the [Design Requirements](#) section.

Physical components, such as a plastic housing and a window that allows light from outside of the design to illuminate the sensor (see [Figure 30](#)), can help protect the OPT3006 and neighboring circuitry. Sometimes, a dark or opaque window is used to further enhance the visual appeal of the design by hiding the sensor from view. This window material is typically transparent plastic or glass.

Any physical component that affects the light that illuminates the sensing area of a light sensor also affects the performance of that light sensor. Therefore, for optimal performance, make sure to understand and control the effect of these components. Design a window width and height to permit light from a sufficient field of view to illuminate the sensor. For best performance, use a field of view of at least $\pm 35^\circ$, or ideally $\pm 45^\circ$ or more. Understanding and designing the field of view is discussed further in application report [SBEA002, OPT3001: Ambient Light Sensor Application Guide](#).

Application Information (continued)

The visible-spectrum transmission for dark windows typically ranges between 5% to 30%, but can be less than 1%. Specify a visible-spectrum transmission as low as, but no more than, necessary to achieve sufficient visual appeal because decreased transmission decreases the available light for the sensor to measure. The windows are made dark by either applying an ink to a transparent window material, or including a dye or other optical substance within the window material itself. This attenuating transmission in the visible spectrum of the window creates a ratio between the light on the outside of the design and the light that is measured by the OPT3006. To accurately measure the light outside of the design, compensate the OPT3006 measurement for this ratio.

Ambient light sensors are used to help create ideal lighting experiences for humans; therefore, the matching of the sensor spectral response to that of the human eye response is vital. Infrared light is not visible to the human eye, and can interfere with the measurement of visible light when sensors lack infrared rejection. Therefore, the ratio of visible light to interfering infrared light affects the accuracy of any practical system that represents the human eye. The strong rejection of infrared light by the OPT3006 allows measurements consistent with human perception under high-infrared lighting conditions, such as from incandescent, halogen, or sunlight sources.

Although the inks and dyes of dark windows serve their primary purpose of being minimally transmissive to visible light, some inks and dyes can also be very transmissive to infrared light. The use of these inks and dyes further decreases the ratio of visible to infrared light, and thus decreases sensor measurement accuracy. However, because of the excellent infrared rejection of the OPT3006, this effect is minimized, and good results are achieved under a dark window with similar spectral responses to those shown in [Figure 32](#).

For best accuracy, avoid grill-like window structures, unless the designer understands the optical effects sufficiently. These grill-like window structures create a nonuniform illumination pattern at the sensor that make light measurement results vary with placement tolerances and angle of incidence of the light. If a grill-like structure is desired, the OPT3006 is an excellent sensor choice because it is minimally sensitive to illumination uniformity issues disrupting the measurement process.

Light pipes can appear attractive for aiding in the optomechanical design that brings light to the sensor; however, do not use light pipes with any ambient light sensor unless the system designer fully understands the ramifications of the optical physics of light pipes within the full context of his design and objectives.

8.2 Typical Application

Measuring the ambient light with the OPT3006 mounted on a flexible printed circuit board (FPCB) is described in this section. The schematic for this design is shown in [Figure 29](#).

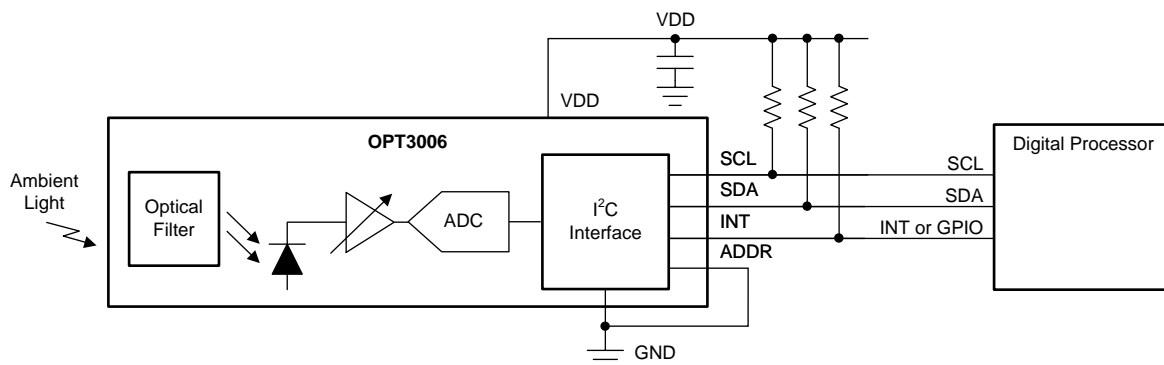

Figure 29. Measuring Ambient Light on an FPCB

Typical Application (continued)

8.2.1 Design Requirements

This design focuses on the field of view, or angular response, of an OPT3006 mounted on an FPCB with an area cut out that permits light to illuminate the sensor. As a result of the geometry of this cutout, the system field of view (angular response) depends on the axis of rotation. One axis of rotation has a less restricted field of view, and the other axis of rotation has a more restricted field of view. The basic requirements of this design are:

- Mount the OPT3006 onto an FPCB with a cutout that allows light to illuminate the sensor.
- The field of view along the axis of rotation with the less restricted field of view must match the device performance.
- The field of view for the more restricted axis of rotation must be minimum of $\pm 30^\circ$.

Field of view is traditionally defined as the angle at which the angular response is 50% of the maximum value of the system response.

8.2.2 Detailed Design Procedure

8.2.2.1 Optomechanical Design

After completing the electrical design (see Figure 29), the next task is the optomechanical design of the FPCB cutout. Design this cutout in conjunction with the tolerance capabilities of the FPCB manufacturer. Or, conversely, choose the FPCB manufacturer for its capabilities of optimally creating this cutout. A semi-rectangular shape of the cutout, created with a standard FPCB laser, is presented here. There are many alternate approaches with different cost, tolerance, and performance tradeoffs.

An image of the created FPCB with the rectangular cutout is shown in Figure 30. The long (vertical) direction of the cutout obviously has no effect on the angular response because any shadows created from the FPCB do not come near the sensor. The long cutout direction defines the axis of rotation with the less restricted field of view. The narrow (horizontal) direction of the cutout, which is limited by the electrical connections to OPT3006, can create shadows that can have a minor impact on the angular response. The narrow cutout direction defines the axis of rotation of the more restricted view. The possibility of shadows are illustrated in Figure 31, a cross-sectional diagram showing the OPT3006 device, with the sensing area, soldered to the FPCB with the cutout.

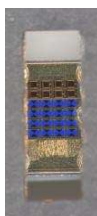

Figure 30. Image of FPCB With OPT3006 Mounted, Receiving Light Through the Cutout

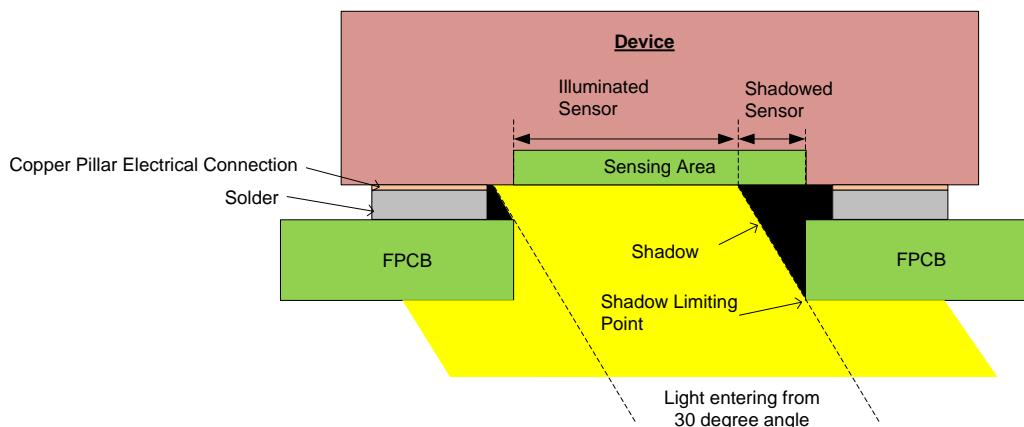

Figure 31. Cross-Sectional Diagram of OPT3006 Soldered to an FPCB With a Cutout, Including Light Entering From an Angle

Typical Application (continued)

To design the angular response to have greater than 50% response at 30°, the optical mechanisms must be understood. This analysis is simplified by assuming a perfectly rectangular cutout. The concepts for this rectangular cutout apply to nonrectangular cutouts, but require a more complex 3D analysis. The analysis performed here is approximate because the actual cutout is not perfectly rectangular.

The net system response is the response of the device without the shadowing effect, multiplied by the percentage of the device that is illuminated, per [Equation 5](#):

$$\text{Net System Response (\%)} = \text{Device Response (\%)} \times \text{Device Illumination (\%)} \quad (5)$$

The shadow impacts the percentage of the sensor that can be illuminated, as seen in [Figure 31](#). The percent response of a shadowed sensor is the percent of the sensor that is illuminated.

The percent of the sensor that must be illuminated to achieve > 50% response is derived by the sequence of [Equation 6](#) through [Equation 8](#).

$$\text{Net System Response} > 50\% \quad (6)$$

$$\text{Device Response} \times \text{Device Illumination} > 50\% \quad (7)$$

$$\text{Device Illumination} > 50\% / \text{Device Response} \quad (8)$$

The device has a 75% response at 30°, as shown in [Figure 13](#), and is a little less than the expected cosine of 30°. The resulting device illumination is shown in [Equation 9](#).

$$\text{Device Illumination} > 66\% \quad (9)$$

Hence, the 3-dimensional geometry illustrated in [Figure 31](#) must permit greater than 66% of the sensor to be illuminated at a 30° angle of incident light. To quantify the geometry of this design, the post-SMT solder thickness is approximately 37 μm (half the thickness of the pre-SMT solder paste thickness), the copper pillar electrical connection is 7 μm, and the FPCB is 105 μm. Therefore, the shadow limiting point is 37 μm + 7 μm + 105 μm = 149 μm, higher than the sensing surface. The 30° angle shadow extends beyond that shadow limiting point per [Equation 10](#).

$$\text{Shadow} = \tan(\text{Illumination_Angle}) \times \text{Shadow_limiting_height} = \tan(30\text{degrees}) \times 149 \mu\text{m} = 86 \mu\text{m} \quad (10)$$

For this instance of the design and tolerance, the shadow limiting point of FPCB cutout is roughly even with the sensor edge, so 86 μm of the sensor is under shadow. If the shadow limiting point was not even with the sensor edge because of either the design or the tolerances, an extra term is added per the system geometry. Given that the sensor width is 381 μm (per the attached mechanical drawing at the end of this data sheet), the amount of illuminated sensor is 381 μm – 86 μm = 295 μm = 77.4%.

The net response at the 30° angle is predicted by [Equation 11](#)

$$\text{Net System Response} = \text{Device Response} \times \text{Device Illumination} = 75\% \times 77.4\% = 58\% \quad (11)$$

There might be an additional need to put a product casing over the assembly of OPT3006 and the FPCB. The window sizing and placement for such an assembly is discussed in more rigorous detail in application report [OPT3001: Ambient Light Sensor Application Guide](#) (SBEA002).

Typical Application (continued)

8.2.3 Application Curves

To validate the angular response of the design, put a light source in a fixed position, allow the device assembly to rotate, and take device measurements at a series of angles. The resulting angular response of this design along the less-restricted rotational axis is shown in Figure 32. The resulting angular response of the more-restricted rotational axis is shown in Figure 33. The response of the device at a 30° angle is approximately 60%, and is very close to the 58% predicted by Equation 11 in the preceding analysis.

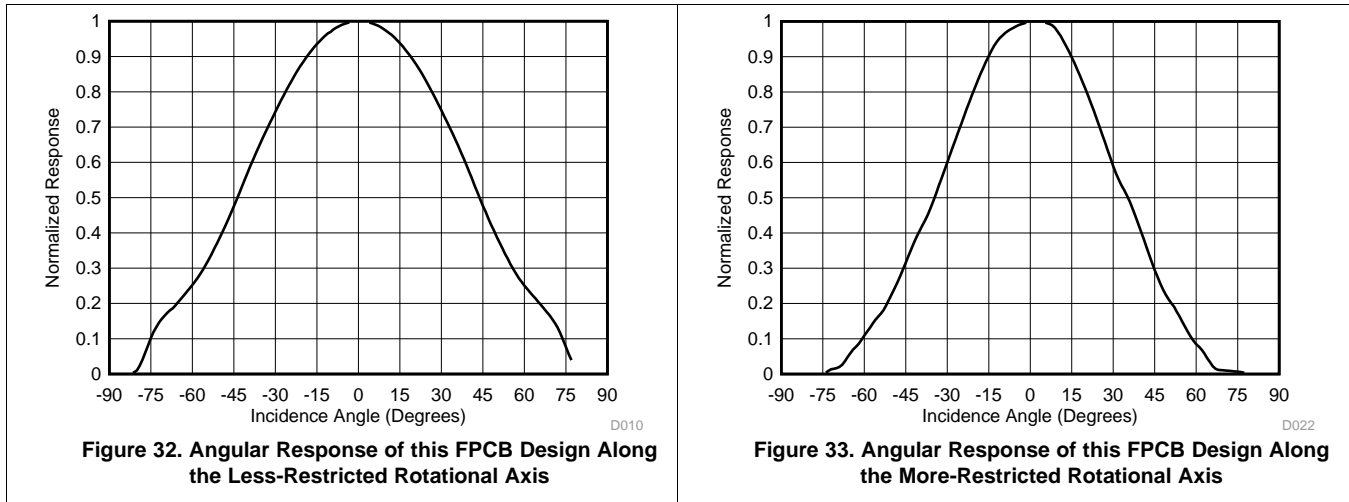

8.3 Do's and Don'ts

As with any optical product, take special care when handling the OPT3006. The OPT3006 is a piece of active silicon, without the mechanical protection of an epoxy-like package or other reenforcement. This design allows the device to be as thin as possible. Take extra care to handle the device gently in order to not crack or break the device. Use a properly-sized vacuum manipulation tool to handle the device.

Although the OPT3006 has low sensitivity to dust and scratches, proper optical device handling procedures are still required.

The optical surface of the device must be kept clean for optimal performance, both when prototyping with the device, and during mass production manufacturing procedures. Keep the optical surface clean of fingerprints, dust, and other optical-inhibiting contaminants.

If the optical surface of the device requires cleaning, use a few gentle brushes with a soft swab of deionized water or isopropyl alcohol. Avoid potentially abrasive cleaning and manipulating tools and excessive force that can scratch the optical surface.

If the OPT3006 performs less than optimally, inspect the optical surface for dirt, scratches, or other optical artifacts.

9 Power-Supply Recommendations

Although the OPT3006 has low sensitivity to power-supply issues, good practices are always recommended. For best performance, the OPT3006 VDD pin must have a stable, low-noise power supply with a 100-nF bypass capacitor close to the device, and solid grounding. There are many options for powering the OPT3006 because the device current consumption levels are very low.

10 Layout

10.1 Layout Guidelines

The PCB layout design for the OPT3006 requires a couple of considerations. The design of the cutout to allow light to illuminate the sensor is a critical part of this design. See the [Optomechanical Design](#) section for a more detailed discussion of creating this cutout.

The device layout is also critical for optimal SMT assembly. Two types of land pattern pads can be used for this package: solder mask defined pads (SMD) and non-solder mask defined pads (NSMD). SMD pads have a solder mask opening that is smaller than the metal pads, whereas NSMD has a solder mask opening that is larger than the metal pad. [Figure 34](#) illustrates these types of landing-pattern pads. SMD is preferred because it provides a more accurate soldering-pad dimension with the trace connections. For further discussion of SMT and PCB recommendations, see the [Soldering and Handling Recommendations](#) section.

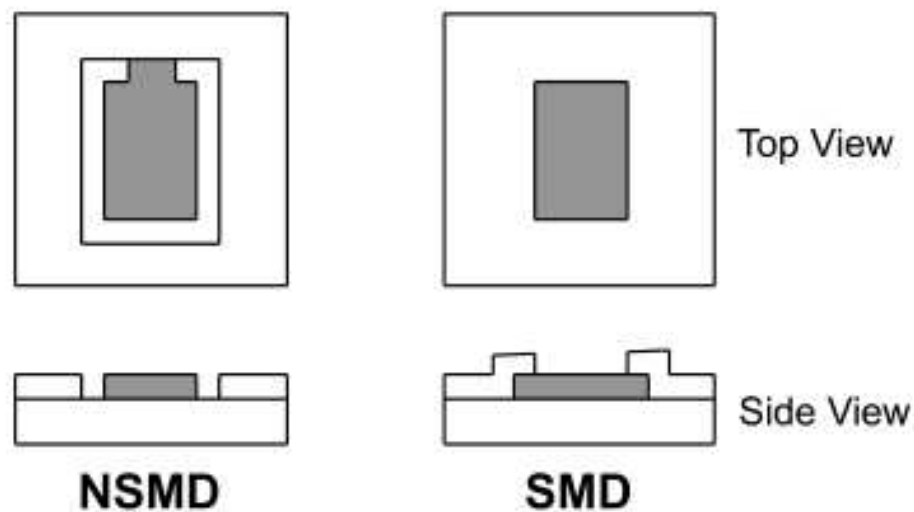

Figure 34. Soldermask Defined Pad (SMD) and Non-Soldermask Defined Pad (NSMD)

Stabilize the power supply with a capacitor placed close to the OPT3006 VDD and GND pins. Note that optically reflective surfaces of components also affect the performance of the design. The three-dimensional geometry of all components and structures around the sensor must be taken into consideration to prevent unexpected results from secondary optical reflections. Placing capacitors and components at a distance of at least twice the height of the component is usually sufficient, although further placement can still achieve good results. The most optimal optical layout is to place all close components on the opposite side of the PCB from the OPT3006. However, this approach may not be practical for the constraints of every design.

An example PCB layout with the OPT3006 is shown in [Figure 36](#).

10.2 Soldering and Handling Recommendations

The OPT3006 is a very small device with special soldering and handling considerations. See [Optomechanical Design](#) for implications of alignment between the device and the cutout area. See [Layout Guidelines](#) for considerations of the soldering pads.

As with most optical devices, handle the OPT3006 with special care to make sure optical surfaces stay clean and free from damage. See the [Do's and Don'ts](#) section for more detailed recommendations. For best optical performance, clean solder flux and any other possible debris after soldering processes.

Soldering and Handling Recommendations (continued)

10.2.1 Solder Paste

For solder-paste deposition, use a stencil-printing process that involves the transfer of solder paste through predefined apertures with the application of pressure. Stencil parameters, such as aperture area ratio and fabrication process, have a significant impact on paste deposition. Cut the stencil apertures using a laser with an electropolish-fabrication method. Taper the stencil aperture walls by 5° to facilitate paste release. Shifting the solder-paste towards the outside of the device minimizes the possibility of solder getting into the device sensing area. See the mechanical packages attached to the end of this data sheet.

Use solder paste selection type 4 or higher, no-clean, lead-free solder paste. If solder splatters in the reflow process, choose a solder paste with normal- or low-flux contents, or alter the reflow profile per the [Reflow Profile](#) section.

10.2.2 Package Placement

Use a pick-and-place nozzle with a size number larger than 0.6 mm. If the placement method is done by programming the component thickness, add 0.04 mm to the actual component thickness so that the package sits halfway into the solder paste. If placement is by force, then choose minimum force no larger than 3N in order to avoid forcing out solder paste, or free falling the package, and to avoid soldering problems such as bridging and solder balling.

10.2.3 Reflow Profile

Use the profile in [Figure 35](#), and adjust if necessary. Use a slow solder reflow ramp rate of 1°C to 1.2°C/s to minimize chances of solder splattering onto the sensing area.

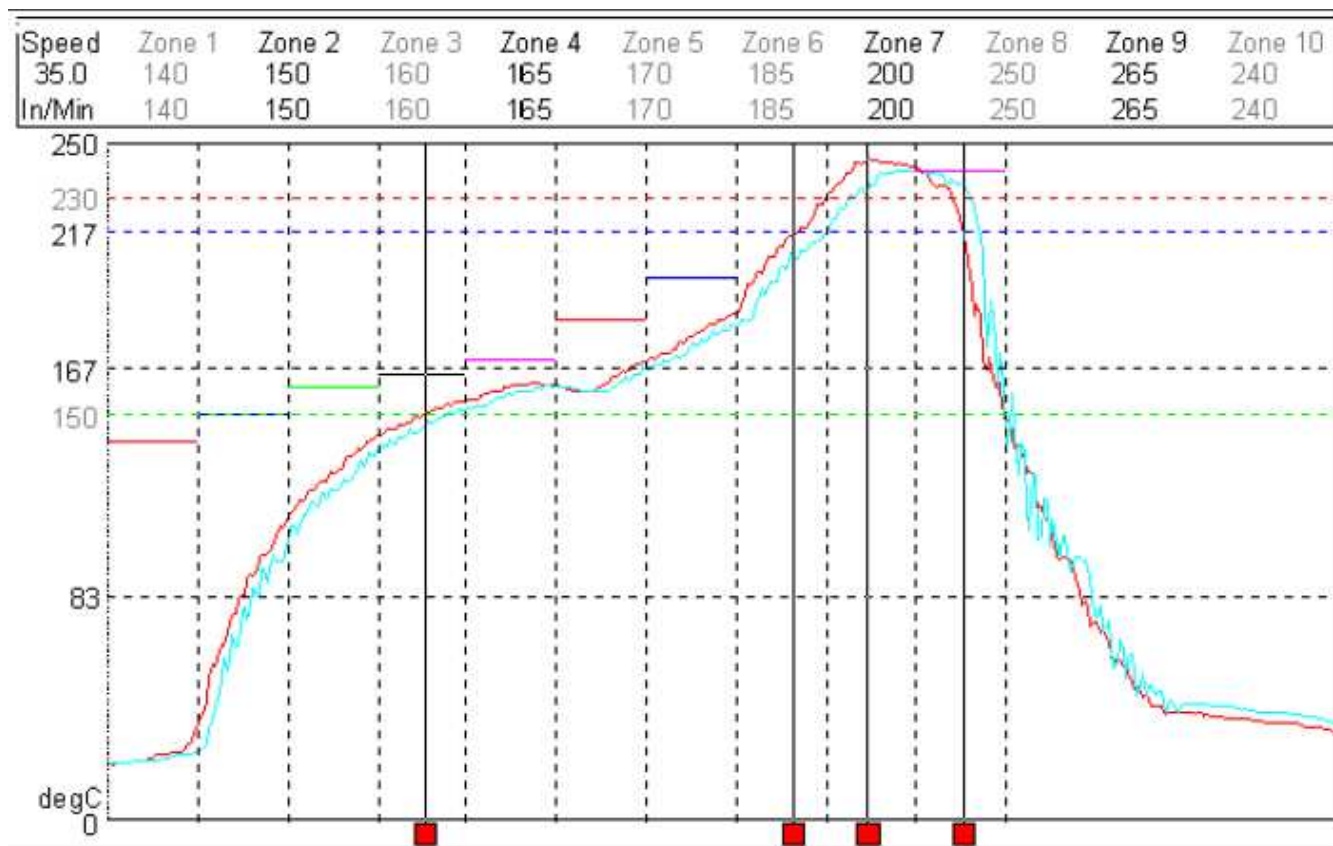

Figure 35. Recommended Solder Reflow Temperature Profile

Soldering and Handling Recommendations (continued)

10.2.4 Special Flexible Printed Circuit Board (FPCB) Recommendations

Special flexible printed circuit board (FPCB) design recommendations include:

- Fabricate per IPC-6013.
- Use material of flexible copper clad per IPC 4204/11 (Define polyimide and copper thickness per product application).
- Finish: All exposed copper will be electroless Ni immersion gold (ENIG) per IPC 4556.
- Solder mask per IPC SM840.
- Use a laser to create the cutout for light sensing for better accuracy, and to avoid affecting the soldering pad dimension. Other options, such as punched cutouts, are possible. See the [Optomechanical Design](#) section for further discussion ranging from the implications of the device to cutout region size and alignment. The full design must be considered, including the tolerances.

To assist the handling of the very thin flexible circuit, design and fabricate a fixture to hold the flexible circuit through the paste-printing, pick-and-place, and reflow processes. Contact the factory for examples of such fixtures.

10.2.5 Rework Process

If the OPT3006 must be removed from a PCB, discard the device and do not reattach. To remove the package from the PCB/Flexi cable, heat the solder joints above liquidus temperature. Bake the board at 125°C for 4 hours prior to rework to remove moisture that may crack the PCB or causing delamination. Use a thermal heating profile to remove a package that is close to the profile that mounts the package. Clean the site to remove any excess solder and residue to prepare for installing a new package. Use a mini stencil (localized stencil) to apply solder paste to the land pattern. In case a mini stencil cannot be used because of spacing or other reasons, apply solder paste on the package pads directly, then mount, and reflow.

10.3 Layout Example

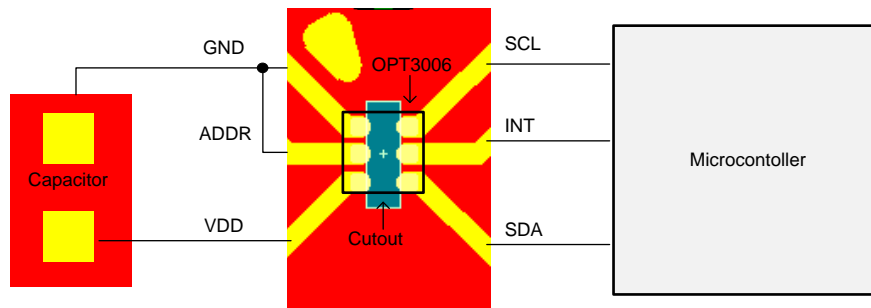

Figure 36. Example FPCB Layout With the OPT3006

11 デバイスおよびドキュメントのサポート

11.1 ドキュメントのサポート

11.1.1 関連資料

関連資料については、以下を参照してください。

- 『OPT3001: 環境光センサ・アプリケーション・ガイド』(SBEA002)
- 『OPT3006EVMユーザー・ガイド』(SBOU181)
- 『QFN/SONのPCB実装』アプリケーション・レポート(SLUA271)

11.2 ドキュメントの更新通知を受け取る方法

ドキュメントの更新についての通知を受け取るには、ti.comのデバイス製品フォルダを開いてください。右上の隅にある「通知を受け取る」をクリックして登録すると、変更されたすべての製品情報に関するダイジェストを毎週受け取れます。変更の詳細については、修正されたドキュメントに含まれている改訂履歴をご覧ください。

11.3 コミュニティ・リソース

The following links connect to TI community resources. Linked contents are provided "AS IS" by the respective contributors. They do not constitute TI specifications and do not necessarily reflect TI's views; see TI's [Terms of Use](#).

TI E2E™ Online Community *TI's Engineer-to-Engineer (E2E) Community*. Created to foster collaboration among engineers. At e2e.ti.com, you can ask questions, share knowledge, explore ideas and help solve problems with fellow engineers.

Design Support *TI's Design Support* Quickly find helpful E2E forums along with design support tools and contact information for technical support.

11.4 商標

PicoStar, E2E are trademarks of Texas Instruments.
All other trademarks are the property of their respective owners.

11.5 静電気放電に関する注意事項



すべての集積回路は、適切なESD保護方法を用いて、取扱いと保存を行うようにして下さい。

静電気放電はわずかな性能の低下から完全なデバイスの故障に至るまで、様々な損傷を与えます。高精度の集積回路は、損傷に対して敏感であり、極めてわずかなパラメータの変化により、デバイスに規定された仕様に適合しなくなる場合があります。

11.6 Glossary

SLYZ022 — *TI Glossary*.

This glossary lists and explains terms, acronyms, and definitions.

12 メカニカル、パッケージ、および注文情報

以降のページには、メカニカル、パッケージ、および注文に関する情報が記載されています。これらの情報は、指定のデバイスに対して提供されている最新のデータです。このデータは予告なく変更されることがあり、ドキュメントが改訂される場合もあります。本データシートのブラウザ版を使用されている場合は、画面左側の説明をご覧ください。

PACKAGING INFORMATION

Orderable part number	Status (1)	Material type (2)	Package Pins	Package qty Carrier	RoHS (3)	Lead finish/ Ball material (4)	MSL rating/ Peak reflow (5)	Op temp (°C)	Part marking (6)
OPT3006YMFR	Active	Production	PICOSTAR (YMF) 6	3000 LARGE T&R	Yes	CUNIPD	Level-1-260C-UNLIM	-40 to 85	6F
OPT3006YMFR.A	Active	Production	PICOSTAR (YMF) 6	3000 LARGE T&R	Yes	CUNIPD	Level-1-260C-UNLIM	-40 to 85	6F
OPT3006YMFT	Obsolete	Production	PICOSTAR (YMF) 6	-	-	Call TI	Call TI	-40 to 85	6F

(1) **Status:** For more details on status, see our [product life cycle](#).

(2) **Material type:** When designated, preproduction parts are prototypes/experimental devices, and are not yet approved or released for full production. Testing and final process, including without limitation quality assurance, reliability performance testing, and/or process qualification, may not yet be complete, and this item is subject to further changes or possible discontinuation. If available for ordering, purchases will be subject to an additional waiver at checkout, and are intended for early internal evaluation purposes only. These items are sold without warranties of any kind.

(3) **RoHS values:** Yes, No, RoHS Exempt. See the [TI RoHS Statement](#) for additional information and value definition.

(4) **Lead finish/Ball material:** Parts may have multiple material finish options. Finish options are separated by a vertical ruled line. Lead finish/Ball material values may wrap to two lines if the finish value exceeds the maximum column width.

(5) **MSL rating/Peak reflow:** The moisture sensitivity level ratings and peak solder (reflow) temperatures. In the event that a part has multiple moisture sensitivity ratings, only the lowest level per JEDEC standards is shown. Refer to the shipping label for the actual reflow temperature that will be used to mount the part to the printed circuit board.

(6) **Part marking:** There may be an additional marking, which relates to the logo, the lot trace code information, or the environmental category of the part.

Multiple part markings will be inside parentheses. Only one part marking contained in parentheses and separated by a "-" will appear on a part. If a line is indented then it is a continuation of the previous line and the two combined represent the entire part marking for that device.

Important Information and Disclaimer: The information provided on this page represents TI's knowledge and belief as of the date that it is provided. TI bases its knowledge and belief on information provided by third parties, and makes no representation or warranty as to the accuracy of such information. Efforts are underway to better integrate information from third parties. TI has taken and continues to take reasonable steps to provide representative and accurate information but may not have conducted destructive testing or chemical analysis on incoming materials and chemicals. TI and TI suppliers consider certain information to be proprietary, and thus CAS numbers and other limited information may not be available for release.

In no event shall TI's liability arising out of such information exceed the total purchase price of the TI part(s) at issue in this document sold by TI to Customer on an annual basis.

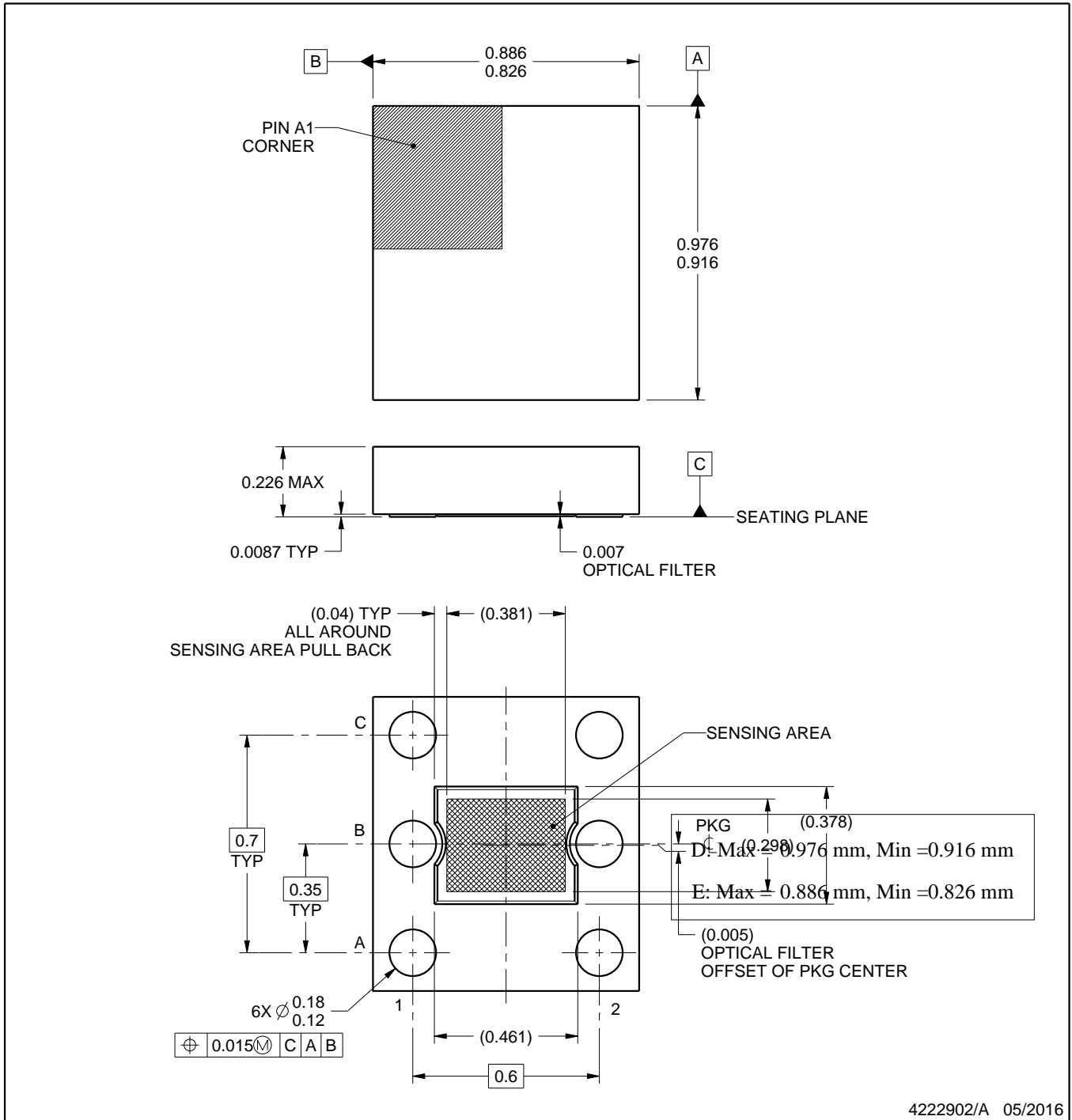
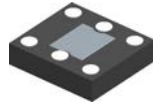

4222902/A 05/2016

NOTES:

PicoStar is a trademark of Texas Instruments.

1. All linear dimensions are in millimeters. Any dimensions in parenthesis are for reference only. Dimensioning and tolerancing per ASME Y14.5M.
2. This drawing is subject to change without notice.

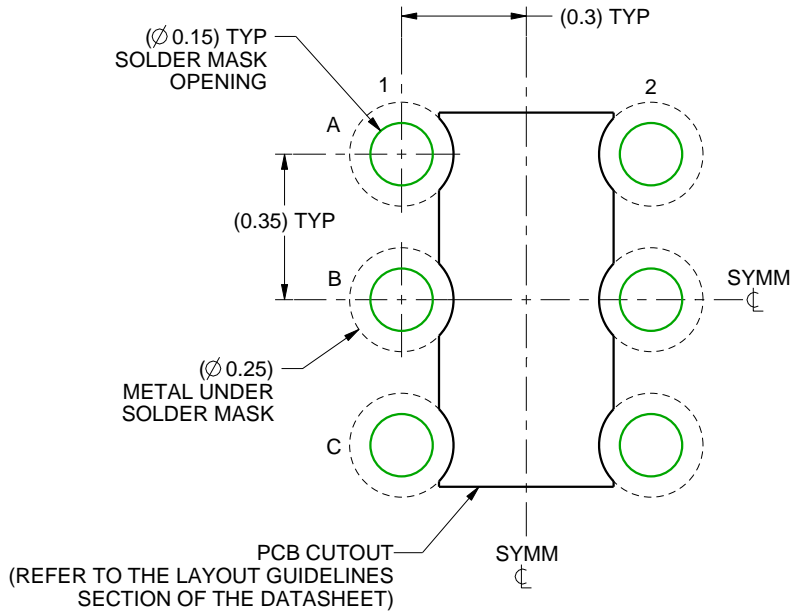

LAND PATTERN EXAMPLE
SCALE: 55X

4222902/A 05/2016

NOTES: (continued)

- 3. Final dimensions may vary due to manufacturing tolerance considerations and also routing constraints. For more information, see Texas Instruments literature number SLUA271 (www.ti.com/lit/slua271).

EXAMPLE STENCIL DESIGN

YMF0006A

PicoStar™ - 0.226 mm max height

PicoStar

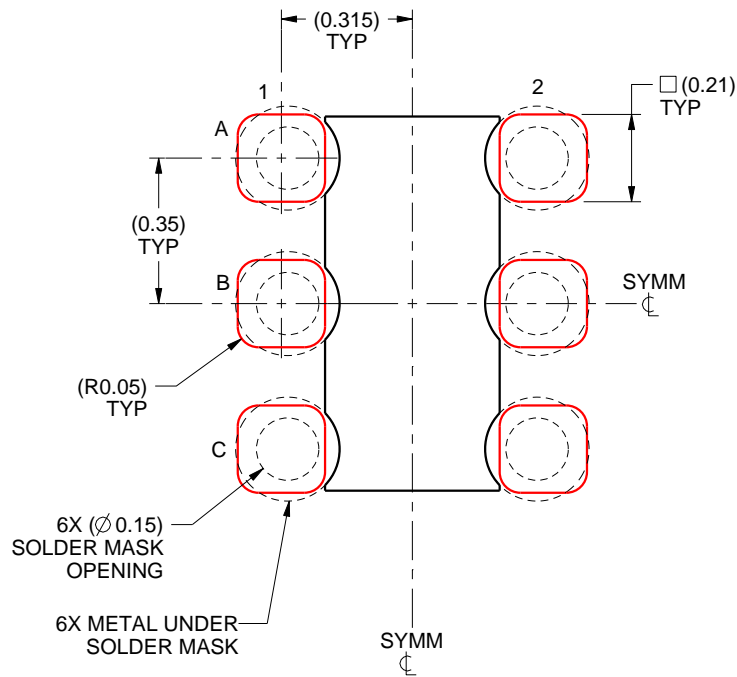

SOLDER PASTE EXAMPLE
BASED on 0.075 mm THICK STENCIL
SCALE: 55X

4222902/A 05/2016

NOTES: (continued)

4. Laser cutting apertures with trapezoidal walls and rounded corners may offer better paste release.

重要なお知らせと免責事項

テキサス・インスツルメンツは、技術データと信頼性データ(データシートを含みます)、設計リソース(リファレンス デザインを含みます)、アプリケーションや設計に関する各種アドバイス、Web ツール、安全性情報、その他のリソースを、欠陥が存在する可能性のある「現状のまま」提供しており、商品性および特定目的に対する適合性の黙示保証、第三者の知的財産権の非侵害保証を含むいかなる保証も、明示的または黙示的にかかわらず拒否します。

これらのリソースは、テキサス・インスツルメンツ製品を使用する設計の経験を積んだ開発者への提供を意図したものです。(1) お客様のアプリケーションに適したテキサス・インスツルメンツ製品の選定、(2) お客様のアプリケーションの設計、検証、試験、(3) お客様のアプリケーションに該当する各種規格や、その他のあらゆる安全性、セキュリティ、規制、または他の要件への確実な適合に関する責任を、お客様のみが単独で負うものとし、ます。

上記の各種リソースは、予告なく変更される可能性があります。これらのリソースは、リソースで説明されているテキサス・インスツルメンツ製品を使用するアプリケーションの開発の目的でのみ、テキサス・インスツルメンツはその使用をお客様に許諾します。これらのリソースに関して、他の目的で複製することや掲載することは禁止されています。テキサス・インスツルメンツや第三者の知的財産権のライセンスが付与されている訳ではありません。お客様は、これらのリソースを自身で使用した結果発生するあらゆる申し立て、損害、費用、損失、責任について、テキサス・インスツルメンツおよびその代理人を完全に補償するものとし、テキサス・インスツルメンツは一切の責任を拒否します。

テキサス・インスツルメンツの製品は、[テキサス・インスツルメンツの販売条件](#)、または [ti.com](https://www.ti.com) やかかるテキサス・インスツルメンツ製品の関連資料などのいずれかを通じて提供する適用可能な条項の下で提供されています。テキサス・インスツルメンツがこれらのリソースを提供することは、適用されるテキサス・インスツルメンツの保証または他の保証の放棄の拡大や変更を意味するものではありません。

お客様がいかなる追加条項または代替条項を提案した場合でも、テキサス・インスツルメンツはそれらに異議を唱え、拒否します。

郵送先住所：Texas Instruments, Post Office Box 655303, Dallas, Texas 75265
Copyright © 2025, Texas Instruments Incorporated