

MSP430F677x、MSP430F676x、MSP430F674x多相メータリングSoC

1 デバイスの概要

1.1 特長

- 相電流のダイナミック・レンジ2000:1で誤差0.1%未満の高精度
- ANSI C12.20/IEC 62053規格(またはそれ以上)に適合
- 変流器、ロゴスキー・コイル、シャントなど複数のセンサに対応
- 最大3相+ニュートラルの電力測定
- 較正用の有効/無効電力量専用パルス出力ピン
- 位相ごとまたは累積的な4象限測定
- 正確な位相角測定
- 変流器用デジタル位相補正
- 温度補償付き電力量測定
- シングル・キャリブレーションによる40Hz~70Hzのライン周波数範囲
- 自動スイッチングによる柔軟な電源オプション
- AC主電源障害時もディスプレイは超低消費電力で動作:LPM3で3 μ A
- コントラスト制御を搭載し、最大320セグメントに対応するLCDドライバ
- パスワードで保護されたリアルタイム・クロック(RTC)、水晶振動子オフセット較正および温度補償機能付き
- 改ざん対策と暗号化をサポートするセキュリティ・モジュールを内蔵
- スマート・メータ用の複数の通信インターフェイス
- 32ビット乗算器を搭載した高性能25MHz CPU
- 広い入力電源電圧範囲: 1.8V~3.6V
- 電力量測定中の消費電力が極めて低い
 - 10MHz動作時2.9mW (3V)
- 複数の低消費電力モード
 - スタンバイ・モード(LPM3): 2.1 μ A (3V)、5 μ s以内にウェークアップ
 - RTCモード(LPM3.5): 0.34 μ A (3V)
 - シャットダウン・モード(LPM4.5): 0.18 μ A (3V)
- 最大512KBのシングルサイクル・フラッシュ
- シングルサイクル・アクセスに対応した最大32KBのRAM
- 差動入力と可変ゲインに対応した最大7つの独立した24ビット・シグマ・デルタADC
- 10ビット200kspsのシステムADC
 - 6つのチャンネルと電源/温度センサ測定機能
- 暗号化用ハードウェアAES-128モジュールを内蔵
- 6つの拡張通信ポート
 - 4つのUART、6つのSPI、2つのI²Cインターフェイスで構成可能
- 4つの16ビット・タイマ: 9個のキャプチャ/比較レジスタを装備
- 90のI/Oピンを備えた128ピンLQFP (PEU)パッケージ
- 62のI/Oピンを備えた100ピンLQFP (PZ)パッケージ
- 40°C~85°Cの産業用温度範囲
- 3相電子電力量計開発ツール([ツールとソフトウェア](#)も参照)
 - [EVM430-F6779とアプリケーション・ノート](#)
 - [MSP430™マイコン向けエネルギー測定デザイン・センター](#)

1.2 アプリケーション

- 3相電子電力量計
- ユーティリティ・メータ
- 電力量監視

1.3 概要

TI MSP430F677x ファミリの多相メータリングSoCは、少ない外付け部品で高精度と低システム・コストを実現する、高度に統合された強力な電力量計ソリューションです。F677xファミリは、32ビット乗算器を搭載した低消費電力MSP430 CPUを使用して、あらゆる電力量計算をはじめ、関税率管理などの計量アプリケーション、AMRおよびAMIモジュールとの通信を実行します。

F677xは、TIの24ビット・シグマ・デルタ・コンバータ・テクノロジーにより、誤差0.1%未満の高精度を実現しています。このファミリの製品は最大512KBのフラッシュ、32KBのRAM、最大320セグメントに対応するLCDコントローラを内蔵しています。

超低消費電力のF677xでは、システム消費電力を最小限に抑えて全体的なコストを削減できます。また、スタンバイ時の消費電力が極めて低いため、バックアップ用電源容量を最小限に抑えることができ、主電源障害時にも長時間にわたって重要なデータを保持できます。

F677xファミリでは、TIのエネルギー測定ソフトウェア・ライブラリを実行して、関連するすべての電力量/電力の結果を計算します。エネルギー測定ソフトウェア・ライブラリは、F677xで無償提供されます。業界標準の開発ツールとハードウェア・プラットフォームを利用して、すべてのANSI/IEC規格に適合したメータを世界中で短期間に開発できます。

モジュールの完全な説明については、『MSP430FR5xxおよびMSP430FR6xxファミリ ユーザー・ガイド』を参照してください。

製品情報⁽¹⁾

型番	パッケージ	本体サイズ ⁽²⁾
MSP430F6779IPEU	LQFP (128)	20mm×14mm
MSP430F6779IPZ	LQFP (100)	14mm×14mm

- (1) 最新のデバイス、パッケージ、および注文情報については、8の「付録:パッケージ・オプション」または、www.ti.comのTI Webサイトを参照してください。
- (2) ここに記載されているサイズは概略です。許容公差を含めたパッケージの寸法については、8の「メカニカル・データ」を参照してください。

1.4 アプリケーション図

図 1-1 に代表的アプリケーション図を示します。



図 1-1. MSP430F677xを使用した3相4線式スター結線

Table of Contents

1	デバイスの概要	1	5.31	Auxiliary Supplies, Switching Time	43
1.1	特長	1	5.32	Auxiliary Supplies, Switch Leakage	43
1.2	アプリケーション	1	5.33	Auxiliary Supplies, Auxiliary Supplies to ADC10_A	43
1.3	概要	2	5.34	Auxiliary Supplies, Charge Limiting Resistor	43
1.4	アプリケーション図	3	5.35	Timer_A	44
2	改訂履歴	6	5.36	eUSCI (UART Mode) Clock Frequency	44
3	Device Comparison	7	5.37	eUSCI (UART Mode)	44
3.1	Related Products	8	5.38	eUSCI (SPI Master Mode) Clock Frequency	45
4	Terminal Configuration and Functions	9	5.39	eUSCI (SPI Master Mode)	45
4.1	Pin Diagrams	9	5.40	eUSCI (SPI Slave Mode)	46
4.2	Signal Descriptions	13	5.41	eUSCI (I ² C Mode)	48
5	Specifications	26	5.42	Schmitt-Trigger Inputs, RTC Tamper Detect Pin	49
5.1	Absolute Maximum Ratings	26	5.43	Inputs, RTC Tamper Detect Pin	49
5.2	ESD Ratings	26	5.44	Leakage Current, RTC Tamper Detect Pin	49
5.3	Recommended Operating Conditions	26	5.45	Outputs, RTC Tamper Detect Pin	49
5.4	Active Mode Supply Current Into V _{CC} Excluding External Current	28	5.46	LCD_C Recommended Operating Conditions	50
5.5	Low-Power Mode Supply Currents (Into V _{CC}) Excluding External Current	29	5.47	LCD_C Electrical Characteristics	51
5.6	Low-Power Mode With LCD Supply Currents (Into V _{CC}) Excluding External Current	30	5.48	SD24_B Power Supply and Recommended Operating Conditions	52
5.7	Thermal Packaging Characteristics	31	5.49	SD24_B Analog Input	52
5.8	Schmitt-Trigger Inputs – General-Purpose I/O	32	5.50	SD24_B Supply Currents	53
5.9	Inputs – Ports P1 and P2	32	5.51	SD24_B Performance	54
5.10	Leakage Current – General-Purpose I/O	32	5.52	SD24_B, AC Performance	56
5.11	Outputs – General-Purpose I/O (Full Drive Strength)	33	5.53	SD24_B, AC Performance	56
5.12	Outputs – General-Purpose I/O (Reduced Drive Strength)	33	5.54	SD24_B, AC Performance	56
5.13	Output Frequency – General-Purpose I/O	33	5.55	SD24_B External Reference Input	57
5.14	Typical Characteristics – Outputs, Reduced Drive Strength (PxDS.y = 0)	34	5.56	10-Bit ADC Power Supply and Input Range Conditions	58
5.15	Typical Characteristics – Outputs, Full Drive Strength (PxDS.y = 1)	35	5.57	10-Bit ADC Switching Characteristics	58
5.16	Crystal Oscillator, XT1, Low-Frequency Mode	36	5.58	10-Bit ADC Linearity Parameters	59
5.17	Internal Very-Low-Power Low-Frequency Oscillator (VLO)	37	5.59	10-Bit ADC External Reference	59
5.18	Internal Reference, Low-Frequency Oscillator (REFO)	37	5.60	REF Built-In Reference	60
5.19	DCO Frequency	38	5.61	Comparator_B	61
5.20	PMM, Brownout Reset (BOR)	39	5.62	Flash Memory	62
5.21	PMM, Core Voltage	39	5.63	JTAG and Spy-Bi-Wire Interface	62
5.22	PMM, SVS High Side	40	6	Detailed Description	63
5.23	PMM, SVM High Side	40	6.1	Functional Block Diagrams	63
5.24	PMM, SVS Low Side	41	6.2	CPU (Link to User's Guide)	64
5.25	PMM, SVM Low Side	41	6.3	Instruction Set	65
5.26	Wake-up Times From Low-Power Modes and Reset	41	6.4	Operating Modes	66
5.27	Auxiliary Supplies Recommended Operating Conditions	42	6.5	Interrupt Vector Addresses	67
5.28	Auxiliary Supplies, AUXVCC3 (Backup Subsystem) Currents	42	6.6	Special Function Registers (SFRs)	69
5.29	Auxiliary Supplies, Auxiliary Supply Monitor	42	6.7	Memory Organization	70
5.30	Auxiliary Supplies, Switch ON-Resistance	43	6.8	Bootloader (BSL)	72
			6.9	JTAG Operation	72
			6.10	Flash Memory (Link to User's Guide)	73
			6.11	RAM (Link to User's Guide)	73
			6.12	Backup RAM (Link to User's Guide)	73
			6.13	Peripherals	74
			6.14	Input/Output Diagrams	100
			6.15	Device Descriptors (TLV)	154
7	デバイスおよびドキュメントのサポート	157			

7.1	使い始めと次の手順.....	157	7.7	商標	163
7.2	Device Nomenclature	157	7.8	静電気放電に関する注意事項	164
7.3	ツールとソフトウェア	159	7.9	Export Control Notice	164
7.4	ドキュメントのサポート.....	161	7.10	Glossary.....	164
7.5	関連リンク	163	8	メカニカル、パッケージ、および注文情報	165
7.6	Community Resources.....	163			

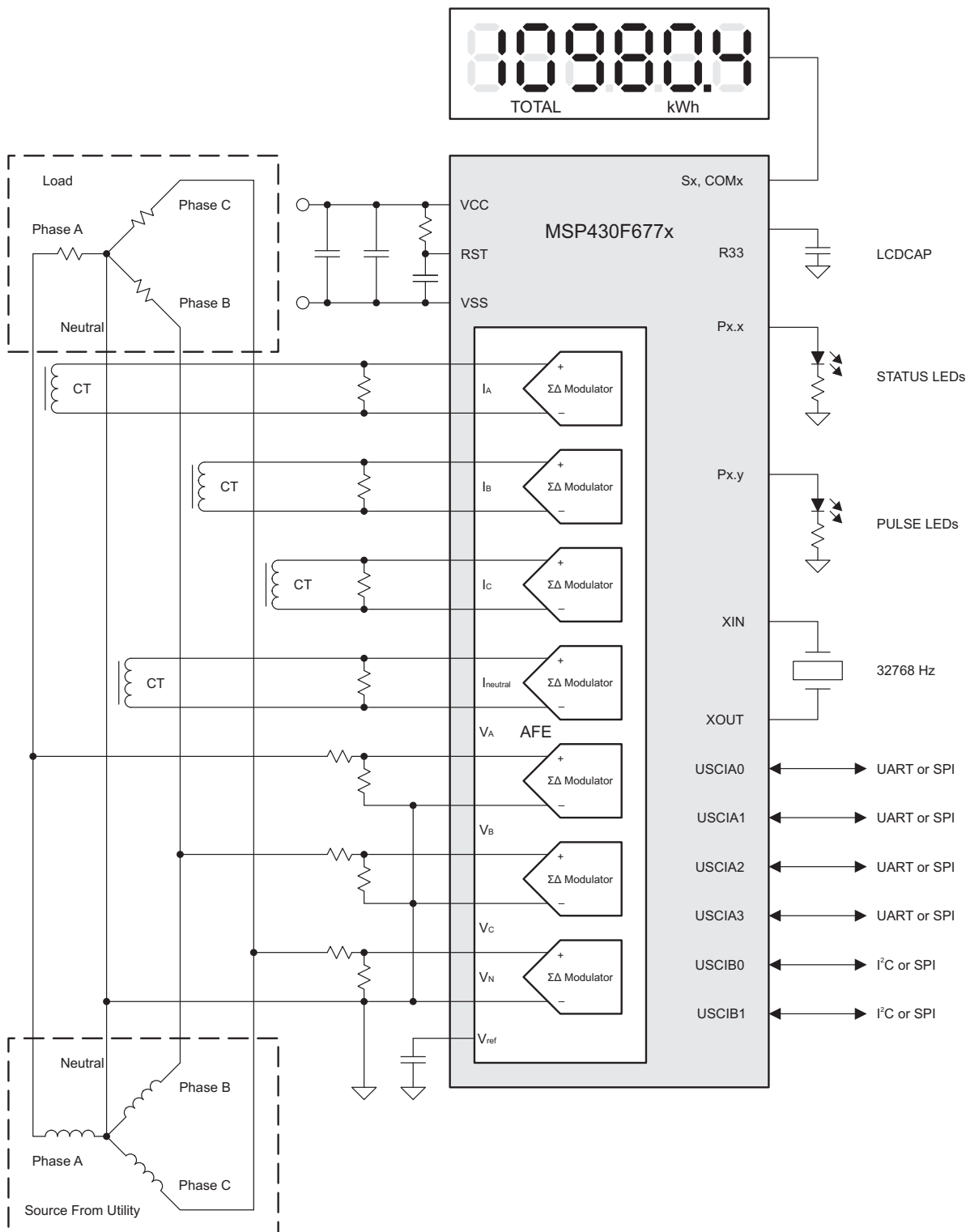
2 改訂履歴

資料番号末尾の英字は改訂を表しています。その改訂履歴は英語版に準じています。

2013年12月19日発行分から2018年09月28日発行分への変更	Page
<ul style="list-style-type: none"> 全体を通してドキュメントのフォーマットを変更、セクションの番号追加も含む 1 「特長」の開発ツールとデザイン・センターへのリンクを更新 1 	
<ul style="list-style-type: none"> 「製品情報」表を追加 2 Added Section 3, <i>Device Comparison</i>, and moved Table 3-1 to it..... 7 Added Section 3.1, <i>Related Products</i> 8 Added Section 4 and moved pinouts and terminal functions tables to it 9 Corrected the port number (P4.2) on pin 61 in Figure 4-2, <i>100-Pin PZ Package (Top View)</i> 11 Added note to P1.3/ADC10CLK/A3 (pin 8) in Table 4-3, <i>Terminal Functions – PEU Package</i>..... 13 Added typical conditions statements at the beginning of Section 5, <i>Specifications</i> 26 Moved all electrical specifications to Section 5..... 26 Added SD24_B input pins and AUXVCCx pins to exception list on "Voltage applied to pins" parameter, and added SD24_B input pin limits in "Diode current at pins" parameter in Section 5.1, <i>Absolute Maximum Ratings</i>..... 26 Added Section 5.2, <i>ESD Ratings</i>..... 26 Added note to $C_{V_{CORE}}$..... 26 Added Section 5.7, <i>Thermal Packaging Characteristics</i> 31 Changed the TYP value of the $C_{L,eff}$ parameter with Test Conditions of "XTS = 0, XCAPx = 0" from 2 pF to 1 pF in Section 5.16, <i>Crystal Oscillator, XT1, Low-Frequency Mode</i>..... 36 Updated notes (1) and (2) and added note (3) in Section 5.26, <i>Wake-up Times From Low-Power Modes and Reset</i> 41 Corrected the names of the AUXVCC1, AUXVCC2, and AUXVCC3 pins in Auxiliary Supplies tables..... 42 Corrected the bit name in the Test Conditions of the R_{CHARGE} parameter (changed CHCx to AUXCHCx) in Section 5.34, <i>Auxiliary Supplies, Charge Limiting Resistor</i>..... 43 Replaced f_{Frame} parameter with f_{LCD}, $f_{FRAME,4mux}$, and $f_{FRAME,8mux}$ parameters in Section 5.46, <i>LCD_C Recommended Operating Conditions</i> 50 On the $V_{ID,FS}$ parameter in Section 5.48, <i>SD24_B Power Supply and Recommended Operating Conditions</i>: Changed the MIN value from "$V_{REF}/GAIN$" to "$-V_{REF}/GAIN$"; Removed "Unipolar mode" test condition (mode is not supported) 52 Removed ADC10DIV from the formula for the TYP value in the second row of the $t_{CONVERT}$ parameter in Section 5.57, <i>10-Bit ADC Switching Characteristics</i>, because ADC10CLK is after division 58 Changed Test Conditions for all parameters in Section 5.58, <i>10-Bit ADC Linearity Parameters</i>: Removed "V_{REF-}"; Changed from "$(V_{eREF+} - V_{eREF-})_{min} \leq (V_{eREF+} - V_{eREF-})$" to "$1.4 V \leq (V_{eREF+} - V_{eREF-})$"; Changed from "$C_{V_{REF+}} = 20 pF$" to "$C_{V_{eREF+}} = 20 pF$"; Added "$C_{V_{eREF+}} = 20 pF$" to E_j; Added "ADC10SREFx = 11b" to E_T and E_G.. 59 Removed "V_{REF-}" from the Test Conditions for the V_{eREF+}, V_{eREF-}, and $(V_{eREF+} - V_{eREF-})$ parameters in Section 5.59, <i>10-Bit ADC External Reference</i>..... 59 Changed MIN value of $AV_{CC(min)}$ parameter with Test Conditions of "REFVSEL = {0} for 1.5 V" from 2.2 V to 1.8 V in Section 5.60, <i>REF Built-In Reference</i> 60 Changed the MAX value of the $t_{EN,CMP}$ parameter with Test Conditions of "CBPWRMD = 10" from 50 μs to 100 μs in Section 5.61, <i>Comparator_B</i>..... 61 Throughout document, changed all instances of "bootstrap loader" to "bootloader" 72 Corrected spelling of NMIIFG in Table 6-13, <i>System Module Interrupt Vector Registers</i> 78 7を追加して、「開発ツールのサポート」、「デバイスと開発ツールの項目表記」、「商標」セクションをそこに移動 157 従来の「開発ツールのサポート」セクションを 7.3「ツールとソフトウェア」セクションに入れ替え 159 8「メカニカル、パッケージ、および注文情報」を追加 165 	

3 Device Comparison

Table 3-1 summarizes the available family members.

Table 3-1. Device Comparison⁽¹⁾⁽²⁾

DEVICE	FLASH (KB)	SRAM (KB)	SD24_B CONVERTERS	ADC10_A CHANNELS	Timer_A ⁽³⁾	eUSCI_A: UART, IrDA, SPI	eUSCI_B: SPI, I ² C	I/Os	PACKAGE
MSP430F6779IPEU	512	32	7	6 ext, 2 int	3, 2, 2, 2	4	2	90	128 PEU
MSP430F6778IPEU	512	16	7	6 ext, 2 int	3, 2, 2, 2	4	2	90	128 PEU
MSP430F6777IPEU	256	32	7	6 ext, 2 int	3, 2, 2, 2	4	2	90	128 PEU
MSP430F6776IPEU	256	16	7	6 ext, 2 int	3, 2, 2, 2	4	2	90	128 PEU
MSP430F6775IPEU	128	16	7	6 ext, 2 int	3, 2, 2, 2	4	2	90	128 PEU
MSP430F6769IPEU	512	32	6	6 ext, 2 int	3, 2, 2, 2	4	2	90	128 PEU
MSP430F6768IPEU	512	16	6	6 ext, 2 int	3, 2, 2, 2	4	2	90	128 PEU
MSP430F6767IPEU	256	32	6	6 ext, 2 int	3, 2, 2, 2	4	2	90	128 PEU
MSP430F6766IPEU	256	16	6	6 ext, 2 int	3, 2, 2, 2	4	2	90	128 PEU
MSP430F6765IPEU	128	16	6	6 ext, 2 int	3, 2, 2, 2	4	2	90	128 PEU
MSP430F6749IPEU	512	32	4	6 ext, 2 int	3, 2, 2, 2	4	2	90	128 PEU
MSP430F6748IPEU	512	16	4	6 ext, 2 int	3, 2, 2, 2	4	2	90	128 PEU
MSP430F6747IPEU	256	32	4	6 ext, 2 int	3, 2, 2, 2	4	2	90	128 PEU
MSP430F6746IPEU	256	16	4	6 ext, 2 int	3, 2, 2, 2	4	2	90	128 PEU
MSP430F6745IPEU	128	16	4	6 ext, 2 int	3, 2, 2, 2	4	2	90	128 PEU
MSP430F6779IPZ	512	32	7	6 ext, 2 int	3, 2, 2, 2	4	2	62	100 PZ
MSP430F6778IPZ	512	16	7	6 ext, 2 int	3, 2, 2, 2	4	2	62	100 PZ
MSP430F6777IPZ	256	32	7	6 ext, 2 int	3, 2, 2, 2	4	2	62	100 PZ
MSP430F6776IPZ	256	16	7	6 ext, 2 int	3, 2, 2, 2	4	2	62	100 PZ
MSP430F6775IPZ	128	16	7	6 ext, 2 int	3, 2, 2, 2	4	2	62	100 PZ
MSP430F6769IPZ	512	32	6	6 ext, 2 int	3, 2, 2, 2	4	2	62	100 PZ
MSP430F6768IPZ	512	16	6	6 ext, 2 int	3, 2, 2, 2	4	2	62	100 PZ
MSP430F6767IPZ	256	32	6	6 ext, 2 int	3, 2, 2, 2	4	2	62	100 PZ
MSP430F6766IPZ	256	16	6	6 ext, 2 int	3, 2, 2, 2	4	2	62	100 PZ
MSP430F6765IPZ	128	16	6	6 ext, 2 int	3, 2, 2, 2	4	2	62	100 PZ
MSP430F6749IPZ	512	32	4	6 ext, 2 int	3, 2, 2, 2	4	2	62	100 PZ
MSP430F6748IPZ	512	16	4	6 ext, 2 int	3, 2, 2, 2	4	2	62	100 PZ
MSP430F6747IPZ	256	32	4	6 ext, 2 int	3, 2, 2, 2	4	2	62	100 PZ
MSP430F6746IPZ	256	16	4	6 ext, 2 int	3, 2, 2, 2	4	2	62	100 PZ
MSP430F6745IPZ	128	16	4	6 ext, 2 int	3, 2, 2, 2	4	2	62	100 PZ

- (1) For the most current device, package, and ordering information, see the *Package Option Addendum* in 8, or see the TI website at www.ti.com.
- (2) Package drawings, thermal data, and symbolization are available at www.ti.com/packaging.
- (3) Each number in the sequence represents an instantiation of Timer_A with its associated number of capture/compare registers and PWM output generators available. For example, a number sequence of 3, 5 would represent two instantiations of Timer_A, the first instantiation having 3 and the second instantiation having 5 capture/compare registers and PWM output generators, respectively.

3.1 Related Products

For information about other devices in this family of products or related products, see the following links.

Products for TI Microcontrollers TI's low-power and high-performance MCUs, with wired and wireless connectivity options, are optimized for a broad range of applications.

Products for MSP430 Ultra-Low-Power Microcontrollers One platform. One ecosystem. Endless possibilities. Enabling the connected world with innovations in ultra-low-power microcontrollers with advanced peripherals for precise sensing and measurement.

Companion Products for MSP430F6779 Review products that are frequently purchased or used with this product.

Reference Designs for MSP430F6779 The TI Designs Reference Design Library is a robust reference design library that spans analog, embedded processor, and connectivity. Created by TI experts to help you jump start your system design, all TI Designs include schematic or block diagrams, BOMs, and design files to speed your time to market.

4 Terminal Configuration and Functions

4.1 Pin Diagrams

Figure 4-1 shows the pinout for the MSP430F677x devices in the 128-pin PEU package. Table 4-1 lists the differences among the pinouts for the MSP430F677x, MSP430F676x, and MSP430F674x devices.

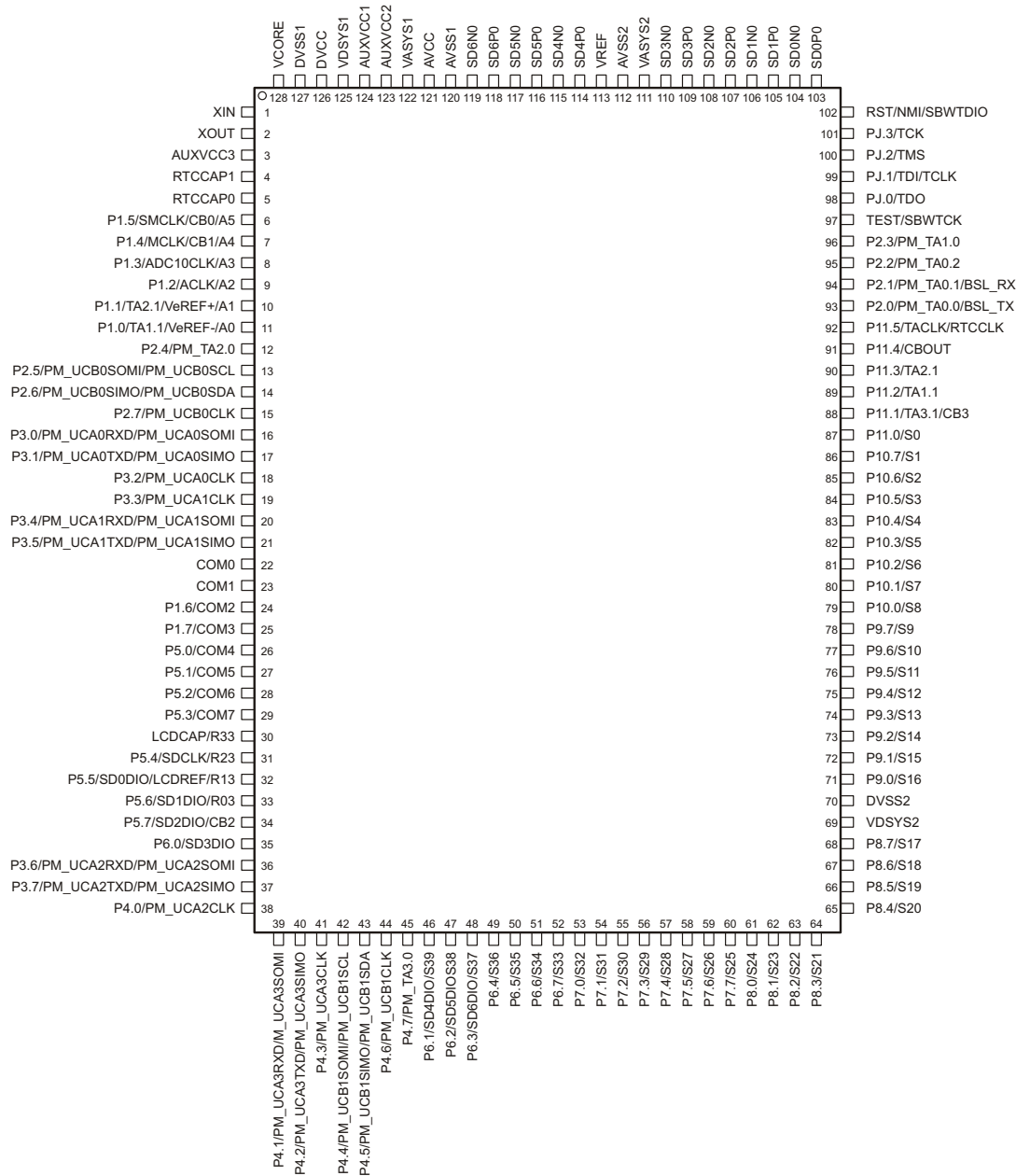

- The secondary digital functions on Ports P2, P3 and P4 are fully mappable. This pinout shows only the default mapping. See Table 6-11 for details.
- The pair of pins VDSYS1 and VDSYS2, VASYS1 and VASYS2 must be connected externally on the board for proper device operation.
- CAUTION:** The LCDCAP/R33 pin must be connected to DVSS if it is not used.

Figure 4-1. 128-Pin PEU Package (Top View)

Table 4-1. Pinout Differences for MSP430F677xIPEU , MSP430F676xIPEU , and MSP430F674xIPEU

PIN NUMBER	PIN NAME		
	MSP430F677xIPEU	MSP430F676xIPEU	MSP430F674xIPEU
46	P6.1/SD4DIO/S39	P6.1/SD4DIO/S39	P6.1/S39
47	P6.2/SD5DIO/S38	P6.2/SD5DIO/S38	P6.2/S38
48	P6.3/SD6DIO/S37	P6.3/S37	P6.3/S37
113	VREF	VREF	VREF
114	SD4P0	SD4P0	NC
115	SD4N0	SD4N0	NC
116	SD5P0	SD5P0	NC
117	SD5N0	SD5NO	NC
118	SD6P0	NC	NC
119	SD6N0	NC	NC

Figure 4-2 shows the pinout for the MSP430F677x devices in the 100-pin PZ package. Table 4-2 lists the differences among the pinouts for the MSP430F677x, MSP430F676x, and MSP430F674x devices.

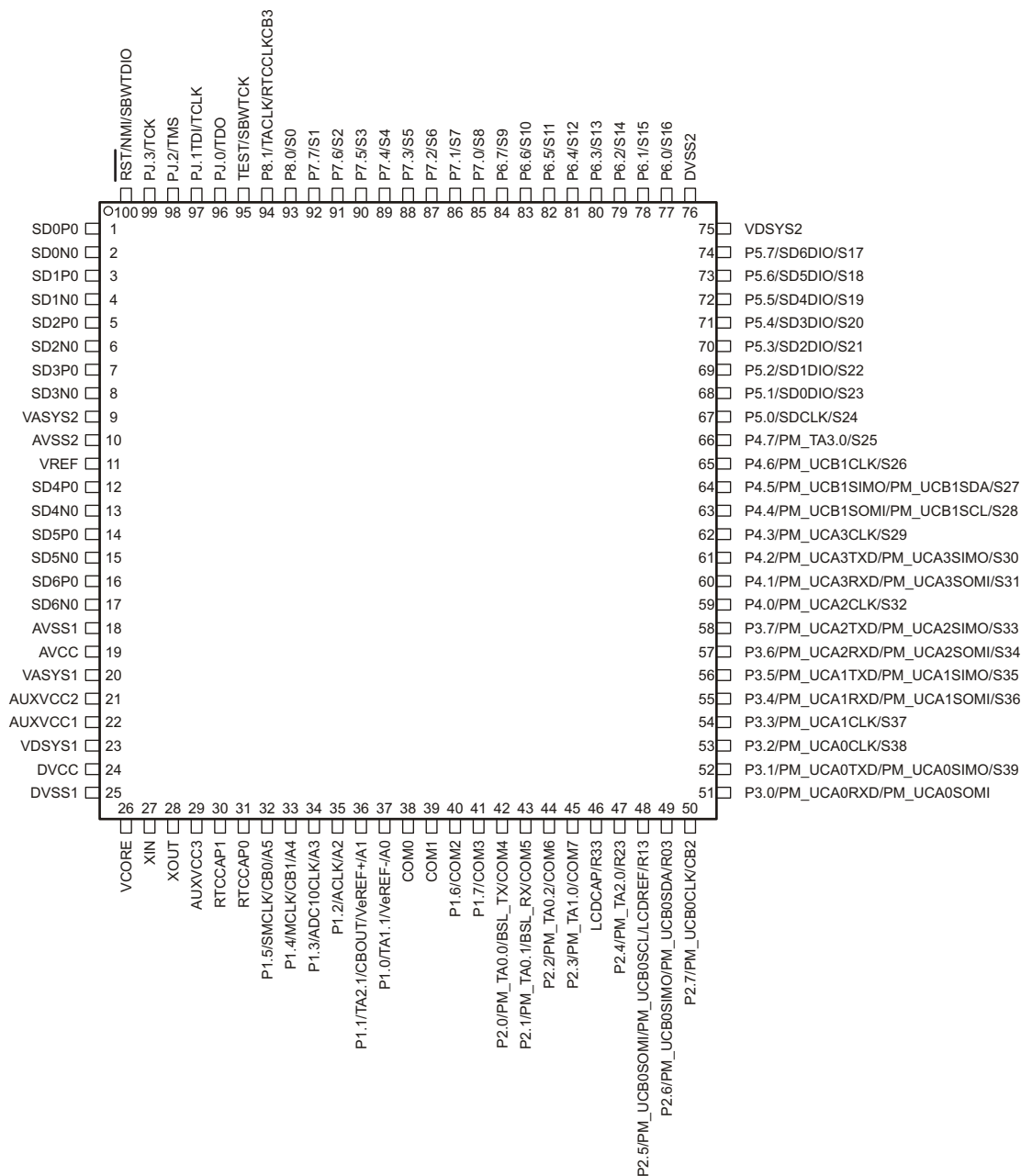

- A. The secondary digital functions on Ports P2, P3 and P4 are fully mappable. This pinout shows only the default mapping. See Table 6-11 for details.
- B. The pair of pins VDSYS1 and VDSYS2, VASYS1 and VASYS2 must be connected externally on the board for proper device operation.
- C. **CAUTION:** The LCDCAP/R33 pin must be connected to DVSS if it is not used.

Figure 4-2. 100-Pin PZ Package (Top View)

Table 4-2. Pinout Differences for MSP430F677xIPZ , MSP430F676xIPZ , and MSP430F674xIPZ

PIN NUMBER	PIN NAME		
	MSP430F677xIPZ	MSP430F676xIPZ	MSP430F674xIPZ
11	VREF	VREF	VREF
12	SD4P0	SD4P0	NC
13	SD4N0	SD4N0	NC
14	SD5P0	SD5P0	NC
15	SD5N0	SD5NO	NC
16	SD6P0	NC	NC
17	SD6N0	NC	NC
72	P5.5/SD4DIO/S19	P5.5/SD4DIO/S19	P5.5/S19
73	P5.6/SD5DIO/S18	P5.6/SD5DIO/S18	P5.6/S18
74	P5.7/SD6DIO/S17	P5.7/S17	P5.7/S17

4.2 Signal Descriptions

Table 4-3 describes the signals for devices in the PEU package. See Table 4-4 for the PZ package signal descriptions.

Table 4-3. Terminal Functions – PEU Package

TERMINAL		I/O ⁽¹⁾	DESCRIPTION
NAME	NO. PEU		
XIN	1	I/O	Input terminal for crystal oscillator
XOUT	2	I/O	Output terminal for crystal oscillator
AUXVCC3	3		Auxiliary power supply AUXVCC3 for back up subsystem
RTCCAP1	4	I	External time capture pin 1 for RTC_C
RTCCAP0	5	I	External time capture pin 0 for RTC_C
P1.5/SMCLK/CB0/A5	6	I/O	General-purpose digital I/O with port interrupt SMCLK clock output Comparator_B input CB0 Analog input A5 for 10-bit ADC
P1.4/MCLK/CB1/A4	7	I/O	General-purpose digital I/O with port interrupt MCLK clock output Comparator_B input CB1 Analog input A4 for 10-bit ADC
P1.3/ADC10CLK/A3 ⁽²⁾	8	I/O	General-purpose digital I/O with port interrupt ADC10_A clock output Analog input A3 for 10-bit ADC
P1.2/ACLK/A2	9	I/O	General-purpose digital I/O with port interrupt ACLK clock output Analog input A2 for 10-bit ADC
P1.1/TA2.1/VeREF+/A1	10	I/O	General-purpose digital I/O with port interrupt Timer TA2 CCR1 capture: CCI1A input, compare: Out1 output Positive terminal for the ADC reference voltage for an external applied reference voltage Analog input A1 for 10-bit ADC
P1.0/TA1.1/VeREF-/A0	11	I/O	General-purpose digital I/O with port interrupt Timer TA1 CCR1 capture: CCI1A input, compare: Out1 output Negative terminal for the ADC reference voltage for an external applied reference voltage Analog input A0 for 10-bit ADC
P2.4/PM_TA2.0	12	I/O	General-purpose digital I/O with port interrupt and mappable secondary function Default mapping: Timer TA2 capture CCR0: CCI0A input, compare: Out0 output
P2.5/PM_UCB0SOMI/ PM_UCB0SCL	13	I/O	General-purpose digital I/O with port interrupt and mappable secondary function Default mapping: eUSCI_B0 SPI slave out master in Default mapping: eUSCI_B0 I ² C clock
P2.6/PM_UCB0SIMO/ PM_UCB0SDA	14	I/O	General-purpose digital I/O with port interrupt and mappable secondary function Default mapping: eUSCI_B0 SPI slave in master out Default mapping: eUSCI_B0 I ² C data
P2.7/PM_UCB0CLK	15	I/O	General-purpose digital I/O with port interrupt and mappable secondary function Default mapping: eUSCI_B0 clock input/output

(1) I = input, O = output

(2) Before enabling the analog function (A3), pull this pin low by setting the port function to output low or to input with the internal pulldown resistor enabled.

Table 4-3. Terminal Functions – PEU Package (continued)

TERMINAL		I/O ⁽¹⁾	DESCRIPTION
NAME	NO. PEU		
P3.0/PM_UCA0RXD/ PM_UCA0SOMI	16	I/O	General-purpose digital I/O with mappable secondary function Default mapping: eUSCI_A0 UART receive data Default mapping: eUSCI_A0 SPI slave out master in
P3.1/PM_UCA0TXD/ PM_UCA0SIMO	17	I/O	General-purpose digital I/O with mappable secondary function Default mapping: eUSCI_A0 UART transmit data Default mapping: eUSCI_A0 SPI slave in master out
P3.2/PM_UCA0CLK	18	I/O	General-purpose digital I/O with mappable secondary function Default mapping: eUSCI_A0 clock input/output
P3.3/PM_UCA1CLK	19	I/O	General-purpose digital I/O with mappable secondary function Default mapping: eUSCI_A1 clock input/output
P3.4/PM_UCA1RXD/ PM_UCA1SOMI	20	I/O	General-purpose digital I/O with mappable secondary function Default mapping: eUSCI_A1 UART receive data Default mapping: eUSCI_A1 SPI slave out master in
P3.5/PM_UCA1TXD/ PM_UCA1SIMO	21	I/O	General-purpose digital I/O with mappable secondary function Default mapping: eUSCI_A1 UART transmit data Default mapping: eUSCI_A1 SPI slave in master out
COM0	22	O	LCD common output COM0 for LCD backplane
COM1	23	O	LCD common output COM1 for LCD backplane
P1.6/COM2	24	I/O	General-purpose digital I/O with port interrupt LCD common output COM2 for LCD backplane
P1.7/COM3	25	I/O	General-purpose digital I/O with port interrupt LCD common output COM3 for LCD backplane
P5.0/COM4	26	I/O	General-purpose digital I/O LCD common output COM4 for LCD backplane
P5.1/COM5	27	I/O	General-purpose digital I/O LCD common output COM5 for LCD backplane
P5.2/COM6	28	I/O	General-purpose digital I/O LCD common output COM6 for LCD backplane
P5.3/COM7	29	I/O	General-purpose digital I/O LCD common output COM7 for LCD backplane
LCDCAP/R33	30	I/O	LCD capacitor connection Input/output port of most positive analog LCD voltage (V1) CAUTION: This pin must be connected to DVSS if not used.
P5.4/SDCLK/R23	31	I/O	General-purpose digital I/O SD24_B bit stream clock input/output Input/output port of second most positive analog LCD voltage (V2)
P5.5/SD0DIO/ LCDREF/R13	32	I/O	General-purpose digital I/O SD24_B converter 0 bit stream data input/output External reference voltage input for regulated LCD voltage Input/output port of third most positive analog LCD voltage (V3 or V4)

Table 4-3. Terminal Functions – PEU Package (continued)

TERMINAL		I/O ⁽¹⁾	DESCRIPTION
NAME	NO. PEU		
P5.6/SD1DIO/R03	33	I/O	General-purpose digital I/O SD24_B converter 1 bit stream data input/output Input/output port of lowest analog LCD voltage (V5)
P5.7/SD2DIO/CB2	34	I/O	General-purpose digital I/O SD24_B converter 2 bit stream data input/output Comparator_B input CB2
P6.0/SD3DIO	35	I/O	General-purpose digital I/O SD24_B converter 3 bit stream data input/output
P3.6/PM_UCA2RXD/ PM_UCA2SOMI	36	I/O	General-purpose digital I/O with mappable secondary function Default mapping: eUSCI_A2 UART receive data Default mapping: eUSCI_A2 SPI slave out master in
P3.7/PM_UCA2TXD/ PM_UCA2SIMO	37	I/O	General-purpose digital I/O with mappable secondary function Default mapping: eUSCI_A2 UART transmit data Default mapping: eUSCI_A2 SPI slave in master out
P4.0/PM_UCA2CLK	38	I/O	General-purpose digital I/O with mappable secondary function Default mapping: eUSCI_A2 clock input/output
P4.1/PM_UCA3RXD/ PM_UCA3SOMI	39	I/O	General-purpose digital I/O with mappable secondary function Default mapping: eUSCI_A3 UART receive data Default mapping: eUSCI_A3 SPI slave out master in
P4.2/PM_UCA3TXD/ PM_UCA3SIMO	40	I/O	General-purpose digital I/O with mappable secondary function Default mapping: eUSCI_A3 UART transmit data Default mapping: eUSCI_A3 SPI slave in master out
P4.3/PM_UCA3CLK	41	I/O	General-purpose digital I/O with mappable secondary function Default mapping: eUSCI_A3 clock input/output
P4.4/PM_UCB1SOMI/ PM_UCB1SCL	42	I/O	General-purpose digital I/O with mappable secondary function Default mapping: eUSCI_B1 SPI slave out, master in Default mapping: eUSCI_B1 I ² C clock
P4.5/PM_UCB1SIMO/ PM_UCB1SDA	43	I/O	General-purpose digital I/O with mappable secondary function Default mapping: eUSCI_B1 SPI slave in, master out Default mapping: eUSCI_B1 I ² C data
P4.6/PM_UCB1CLK	44	I/O	General-purpose digital I/O with mappable secondary function Default mapping: eUSCI_B1 clock input/output
P4.7/PM_TA3.0	45	I/O	General-purpose digital I/O with mappable secondary function Default mapping: Timer TA3 capture CCR0: CCI0A input, compare: Out0 output
P6.1/SD4DIO/S39	46	I/O	General-purpose digital I/O SD24_B converter 4 bit stream data input/output (not available in F674x devices) LCD segment output S39
P6.2/SD5DIO/S38	47	I/O	General-purpose digital I/O SD24_B converter 5 bit stream data input/output (not available in F674x devices) LCD segment output S38

Table 4-3. Terminal Functions – PEU Package (continued)

TERMINAL		I/O ⁽¹⁾	DESCRIPTION
NAME	NO. PEU		
P6.3/SD6DIO/S37	48	I/O	General-purpose digital I/O SD24_B converter 6 bit stream data input/output (not available in F674x, F676x devices) LCD segment output S37
P6.4/S36	49	I/O	General-purpose digital I/O LCD segment output S36
P6.5/S35	50	I/O	General-purpose digital I/O LCD segment output S35
P6.6/S34	51	I/O	General-purpose digital I/O LCD segment output S34
P6.7/S33	52	I/O	General-purpose digital I/O LCD segment output S33
P7.0/S32	53	I/O	General-purpose digital I/O LCD segment output S32
P7.1/S31	54	I/O	General-purpose digital I/O LCD segment output S31
P7.2/S30	55	I/O	General-purpose digital I/O LCD segment output S30
P7.3/S29	56	I/O	General-purpose digital I/O LCD segment output S29
P7.4/S28	57	I/O	General-purpose digital I/O LCD segment output S28
P7.5/S27	58	I/O	General-purpose digital I/O LCD segment output S27
P7.6/S26	59	I/O	General-purpose digital I/O LCD segment output S26
P7.7/S25	60	I/O	General-purpose digital I/O LCD segment output S25
P8.0/S24	61	I/O	General-purpose digital I/O LCD segment output S24
P8.1/S23	62	I/O	General-purpose digital I/O LCD segment output S23
P8.2/S22	63	I/O	General-purpose digital I/O LCD segment output S22
P8.3/S21	64	I/O	General-purpose digital I/O LCD segment output S21
P8.4/S20	65	I/O	General-purpose digital I/O LCD segment output S20
P8.5/S19	66	I/O	General-purpose digital I/O LCD segment output S19
P8.6/S18	67	I/O	General-purpose digital I/O LCD segment output S18

Table 4-3. Terminal Functions – PEU Package (continued)

TERMINAL		I/O ⁽¹⁾	DESCRIPTION
NAME	NO. PEU		
P8.7/S17	68	I/O	General-purpose digital I/O LCD segment output S17
VDSYS2 ⁽³⁾	69		Digital power supply for I/Os
DVSS2	70		Digital ground supply
P9.0/S16	71	I/O	General-purpose digital I/O LCD segment output S16
P9.1/S15	72	I/O	General-purpose digital I/O LCD segment output S15
P9.2/S14	73	I/O	General-purpose digital I/O LCD segment output S14
P9.3/S13	74	I/O	General-purpose digital I/O LCD segment output S13
P9.4/S12	75	I/O	General-purpose digital I/O LCD segment output S12
P9.5/S11	76	I/O	General-purpose digital I/O LCD segment output S11
P9.6/S10	77	I/O	General-purpose digital I/O LCD segment output S10
P9.7/S9	78	I/O	General-purpose digital I/O LCD segment output S9
P10.0/S8	79	I/O	General-purpose digital I/O LCD segment output S8
P10.1/S7	80	I/O	General-purpose digital I/O LCD segment output S7
P10.2/S6	81	I/O	General-purpose digital I/O LCD segment output S6
P10.3/S5	82	I/O	General-purpose digital I/O LCD segment output S5
P10.4/S4	83	I/O	General-purpose digital I/O LCD segment output S4
P10.5/S3	84	I/O	General-purpose digital I/O LCD segment output S3
P10.6/S2	85	I/O	General-purpose digital I/O LCD segment output S2
P10.7/S1	86	I/O	General-purpose digital I/O LCD segment output S1
P11.0/S0	87	I/O	General-purpose digital I/O LCD segment output S0
P11.1/TA3.1/CB3	88	I/O	General-purpose digital I/O Timer TA3 capture CCR1: CC11A input, compare: Out1 output Comparator_B input CB3

(3) The pins VDSYS1 and VDSYS2 must be connected externally on board for proper device operation.

Table 4-3. Terminal Functions – PEU Package (continued)

TERMINAL		I/O ⁽¹⁾	DESCRIPTION
NAME	NO. PEU		
P11.2/TA1.1	89	I/O	General-purpose digital I/O Timer TA1 capture CCR1: CCI1A input, compare: Out1 output
P11.3/TA2.1	90	I/O	General-purpose digital I/O Timer TA2 capture CCR1: CCI1A input, compare: Out1 output
P11.4/CBOUT	91	I/O	General-purpose digital I/O Comparator_B Output
P11.5/TACLK/RTCCLK	92	I/O	General-purpose digital I/O Timer clock input TACLK for TA0, TA1, TA2, TA3 RTCCLK clock output
P2.0/PM_TA0.0/BSL_TX	93	I/O	General-purpose digital I/O with port interrupt and mappable secondary function Default mapping: Timer TA0 capture CCR0: CCI0A input, compare: Out0 output Bootloader: Data transmit
P2.1/PM_TA0.1/BSL_RX	94	I/O	General-purpose digital I/O with port interrupt and mappable secondary function Default mapping: Timer TA0 capture CCR1: CCI1A input, compare: Out1 output Bootloader: Data receive
P2.2/PM_TA0.2	95	I/O	General-purpose digital I/O with port interrupt and mappable secondary function Default mapping: Timer TA0 capture CCR2: CCI2A input, compare: Out2 output
P2.3/PM_TA1.0	96	I/O	General-purpose digital I/O port interrupt and with mappable secondary function Default mapping: Timer TA1 capture CCR0: CCI0A input, compare: Out0 output
TEST/SBWTCK	97	I	Test mode pin – select digital I/O on JTAG pins Spy-Bi-Wire input clock
PJ.0/TDO	98	I/O	General-purpose digital I/O Test data output
PJ.1/TDI/TCLK	99	I/O	General-purpose digital I/O Test data input or Test clock input
PJ.2/TMS	100	I/O	General-purpose digital I/O Test mode select
PJ.3/TCK	101	I/O	General-purpose digital I/O Test clock
$\overline{\text{RST}}/\text{NMI}/\text{SBWTDIO}$	102	I/O	Reset input active low ⁽⁴⁾ Nonmaskable interrupt input Spy-By-Wire data input/output
SD0P0	103	I	SD24_B positive analog input for converter 0 ⁽⁵⁾
SD0N0	104	I	SD24_B negative analog input for converter 0 ⁽⁵⁾
SD1P0	105	I	SD24_B positive analog input for converter 1 ⁽⁵⁾
SD1N0	106	I	SD24_B negative analog input for converter 1 ⁽⁵⁾
SD2P0	107	I	SD24_B positive analog input for converter 2 ⁽⁵⁾
SD2N0	108	I	SD24_B negative analog input for converter 2 ⁽⁵⁾
SD3P0	109	I	SD24_B positive analog input for converter 3 ⁽⁵⁾
SD3N0	110	I	SD24_B negative analog input for converter 3 ⁽⁴⁾
VASYS2	111		Analog power supply selected between AVCC, AUXVCC1, AUXVCC2. Connect recommended capacitor value of C _{VSYS}

(4) When this pin is configured as reset, the internal pullup resistor is enabled by default.

(5) Short unused analog input pairs and connect them to analog ground.

Table 4-3. Terminal Functions – PEU Package (continued)

TERMINAL		I/O ⁽¹⁾	DESCRIPTION
NAME	NO. PEU		
AVSS2	112		Analog ground supply
VREF	113	I	SD24_B external reference voltage
SD4P0	114	I	SD24_B positive analog input for converter 4 ⁽⁵⁾ (not available on F674x devices)
SD4N0	115	I	SD24_B negative analog input for converter 4 ⁽⁵⁾ (not available on F674x devices)
SD5P0	116	I	SD24_B positive analog input for converter 5 ⁽⁵⁾ (not available on F674x devices)
SD5N0	117	I	SD24_B negative analog input for converter 5 ⁽⁵⁾ (not available on F674x devices)
SD6P0	118	I	SD24_B positive analog input for converter 6 ⁽⁵⁾ (not available on F676x, F674x devices)
SD6N0	119	I	SD24_B negative analog input for converter 6 ⁽⁵⁾ (not available on F676x, F674x devices)
AVSS1	120		Analog ground supply
AVCC	121		Analog power supply
VASYS1	122		Analog power supply selected between AVCC, AUXVCC1, AUXVCC2. Connect recommended capacitor value of C _{VSYS} .
AUXVCC2	123		Auxiliary power supply AUXVCC2
AUXVCC1	124		Auxiliary power supply AUXVCC1
VDSYS1 ⁽³⁾	125		Digital power supply selected between DVCC, AUXVCC1, AUXVCC2. Connect recommended capacitor value of C _{VSYS} .
DVCC	126		Digital power supply
DVSS1	127		Digital ground supply
VCORE ⁽⁶⁾	128		Regulated core power supply (internal use only, no external current loading)

(6) VCORE is for internal use only. No external current loading is possible. VCORE should only be connected to the recommended capacitor value, C_{VCORE}.

Table 4-4 describes the signals for devices in the PZ package. See Table 4-3 for the PEU package signal descriptions.

Table 4-4. Terminal Functions – PZ Package

TERMINAL		I/O ⁽¹⁾	DESCRIPTION
NAME	NO. PZ		
SD0P0	1	I	SD24_B positive analog input for converter 0 ⁽²⁾
SD0N0	2	I	SD24_B negative analog input for converter 0 ⁽²⁾
SD1P0	3	I	SD24_B positive analog input for converter 1 ⁽²⁾
SD1N0	4	I	SD24_B negative analog input for converter 1 ⁽²⁾
SD2P0	5	I	SD24_B positive analog input for converter 2 ⁽²⁾
SD2N0	6	I	SD24_B negative analog input for converter 2 ⁽²⁾
SD3P0	7	I	SD24_B positive analog input for converter 3 ⁽²⁾
SD3N0	8	I	SD24_B negative analog input for converter 3 ⁽²⁾
VASYS2	9		Analog power supply selected between AVCC, AUXVCC1, AUXVCC2. Connect recommended capacitor value of C _{VSYS} .
AVSS2	10		Analog ground supply
VREF	11	I	SD24_B external reference voltage
SD4P0	12	I	SD24_B positive analog input for converter 4 ⁽²⁾ (not available on F674x devices)
SD4N0	13	I	SD24_B negative analog input for converter 4 ⁽²⁾ (not available on F674x devices)
SD5P0	14	I	SD24_B positive analog input for converter 5 ⁽²⁾ (not available on F674x devices)
SD5N0	15	I	SD24_B negative analog input for converter 5 ⁽²⁾ (not available on F674x devices)
SD6P0	16	I	SD24_B positive analog input for converter 6 ⁽²⁾ (not available on F676x, F674x devices)
SD6N0	17	I	SD24_B negative analog input for converter 6 ⁽²⁾ (not available on F676x, F674x devices)
AVSS1	18		Analog ground supply
AVCC	19		Analog power supply
VASYS1	20		Analog power supply selected between AVCC, AUXVCC1, AUXVCC2. Connect recommended capacitor value of C _{VSYS}
AUXVCC2	21		Auxiliary power supply AUXVCC2
AUXVCC1	22		Auxiliary power supply AUXVCC1
VDSYS1 ⁽³⁾	23		Digital power supply selected between DVCC, AUXVCC1, AUXVCC2. Connect recommended capacitor value of C _{VSYS} .
DVCC	24		Digital power supply
DVSS1	25		Digital ground supply
VCORE ⁽⁴⁾	26		Regulated core power supply (internal use only, no external current loading)
XIN	27	I/O	Input terminal for crystal oscillator
XOUT	28	I/O	Output terminal for crystal oscillator
AUXVCC3	29		Auxiliary power supply AUXVCC3 for back up subsystem
RTCCAP1	30	I	External time capture pin 1 for RTC_C
RTCCAP0	31	I	External time capture pin 0 for RTC_C
P1.5/SMCLK/CB0/A5	32	I/O	General-purpose digital I/O with port interrupt SMCLK clock output Comparator_B input CB0 Analog input A5 for 10-bit ADC

(1) I = input, O = output

(2) Short unused analog input pairs and connect them to analog ground.

(3) The pins VDSYS1 and VDSYS2 must be connected externally on board for proper device operation.

(4) VCORE is for internal use only. No external current loading is possible. VCORE should only be connected to the recommended capacitor value, C_{VCORE}.

Table 4-4. Terminal Functions – PZ Package (continued)

TERMINAL		I/O ⁽¹⁾	DESCRIPTION
NAME	NO. PZ		
P1.4/MCLK/CB1/A4	33	I/O	General-purpose digital I/O with port interrupt MCLK clock output Comparator_B input CB1 Analog input A4 for 10-bit ADC
P1.3/ADC10CLK/A3	34	I/O	General-purpose digital I/O with port interrupt ADC10_A clock output Analog input A3 for 10-bit ADC
P1.2/ACLK/A2	35	I/O	General-purpose digital I/O with port interrupt ACLK clock output Analog input A2 for 10-bit ADC
P1.1/TA2.1/CBOUT/ VeREF+/A1	36	I/O	General-purpose digital I/O with port interrupt Timer TA2 CCR1 capture: CCI1A input, compare: Out1 output Comparator_B Output Positive terminal for the ADC reference voltage for an external applied reference voltage Analog input A1 for 10-bit ADC
P1.0/TA1.1/VeREF-/A0	37	I/O	General-purpose digital I/O with port interrupt Timer TA1 CCR1 capture: CCI1A input, compare: Out1 output Negative terminal for the ADC reference voltage for an external applied reference voltage Analog input A0 for 10-bit ADC
COM0	38	I/O	LCD common output COM0 for LCD backplane
COM1	39	I/O	LCD common output COM1 for LCD backplane
P1.6/COM2	40	I/O	General-purpose digital I/O with port interrupt LCD common output COM2 for LCD backplane
P1.7/COM3	41	I/O	General-purpose digital I/O with port interrupt LCD common output COM3 for LCD backplane
P2.0/PM_TA0.0/ BSL_TX/COM4	42	I/O	General-purpose digital I/O with port interrupt and mappable secondary function Default Mapping: Timer TA0 CCR0 capture: CCI0A input, compare: Out0 output Bootloader: Data transmit LCD common output COM4 for LCD backplane
P2.1/PM_TA0.1/ BSL_RX/COM5	43	I/O	General-purpose digital I/O with port interrupt and mappable secondary function Default Mapping: Timer TA0 CCR1 capture: CCI1A input, compare: Out1 output Bootloader: Data receive LCD common output COM5 for LCD backplane
P2.2/PM_TA0.2/COM6	44	I/O	General-purpose digital I/O with port interrupt and mappable secondary function Default Mapping: Timer TA0 CCR0 capture: CCI2A input, compare: Out2 output LCD common output COM6 for LCD backplane
P2.3/PM_TA1.0/COM7	45	I/O	General-purpose digital I/O with port interrupt and mappable secondary function Default Mapping: Timer TA1 CCR0 capture: CCI0A input, compare: Out0 output LCD common output COM7 for LCD backplane

Table 4-4. Terminal Functions – PZ Package (continued)

TERMINAL		I/O ⁽¹⁾	DESCRIPTION
NAME	NO.		
	PZ		
LCDCAP/R33	46	I/O	LCD capacitor connection Input/output port of most positive analog LCD voltage (V1) CAUTION: This pin must be connected to DVSS if not used.
P2.4/PM_TA2.0/R23	47	I/O	General-purpose digital I/O with port interrupt and mappable secondary function Default Mapping: Timer TA2 CCR0 capture: CCI0A input, compare: Out0 output Input/output port of second most positive analog LCD voltage (V2)
P2.5/PM_UCB0SOMI/ PM_UCB0SCL/LCDREF/ R13	48	I/O	General-purpose digital I/O with port interrupt and mappable secondary function Default mapping: eUSCI_B0 SPI slave out, master in Default mapping: eUSCI_B0 I ² C clock External reference voltage input for regulated LCD voltage Input/output port of third most positive analog LCD voltage (V3 or V4)
P2.6/PM_UCB0SIMO/ PM_UCB0SDA/R03	49	I/O	General-purpose digital I/O with port interrupt and mappable secondary function Default mapping: eUSCI_B0 SPI slave in, master out Default mapping: eUSCI_B0 I ² C data Input/output port of lowest analog LCD voltage (V5)
P2.7/PM_UCB0CLK/CB2	50	I/O	General-purpose digital I/O with port interrupt and mappable secondary function Default mapping: eUSCI_B0 clock input/output Comparator_B input CB2
P3.0/PM_UCA0RXD/ PM_UCA0SOMI	51	I/O	General-purpose digital I/O with mappable secondary function Default mapping: eUSCI_A0 UART receive data Default mapping: eUSCI_A0 SPI slave out, master in
P3.1/PM_UCA0TXD/ PM_UCA0SIMO/S39	52	I/O	General-purpose digital I/O with mappable secondary function Default mapping: eUSCI_A0 UART transmit data Default mapping: eUSCI_A0 SPI slave in, master out LCD segment output S39
P3.2/PM_UCA0CLK/S38	53	I/O	General-purpose digital I/O with mappable secondary function Default mapping: eUSCI_A0 clock input/output LCD segment output S38
P3.3/PM_UCA1CLK/S37	54	I/O	General-purpose digital I/O with mappable secondary function Default mapping: eUSCI_A1 clock input/output LCD segment output S37
P3.4/PM_UCA1RXD/ PM_UCA1SOMI/S36	55	I/O	General-purpose digital I/O with mappable secondary function Default mapping: eUSCI_A1 UART receive data Default mapping: eUSCI_A1 SPI slave out, master in LCD segment output S36
P3.5/PM_UCA1TXD/ PM_UCA1SIMO/S35	56	I/O	General-purpose digital I/O with mappable secondary function Default mapping: eUSCI_A1 UART transmit data Default mapping: eUSCI_A1 SPI slave in, master out LCD segment output S35

Table 4-4. Terminal Functions – PZ Package (continued)

TERMINAL		I/O ⁽¹⁾	DESCRIPTION
NAME	NO. PZ		
P3.6/PM_UCA2RXD/ PM_UCA2SOMI/S34	57	I/O	General-purpose digital I/O with mappable secondary function Default mapping: eUSCI_A2 UART receive data Default mapping: eUSCI_A2 SPI slave out, master in LCD segment output S34
P3.7/PM_UCA2TXD/ PM_UCA2SIMO/S33	58	I/O	General-purpose digital I/O with mappable secondary function Default mapping: eUSCI_A2 UART transmit data Default mapping: eUSCI_A2 SPI slave in, master out LCD segment output S33
P4.0/PM_UCA2CLK/S32	59	I/O	General-purpose digital I/O with mappable secondary function Default mapping: eUSCI_A2 clock input/output LCD segment output S32
P4.1/PM_UCA3RXD/ PM_UCA3SOMI/S31	60	I/O	General-purpose digital I/O with mappable secondary function Default mapping: eUSCI_A3 UART receive data Default mapping: eUSCI_A3 SPI slave out, master in LCD segment output S31
P4.2/PM_UCA3TXD/ PM_UCA3SIMO/S30	61	I/O	General-purpose digital I/O with mappable secondary function Default mapping: eUSCI_A3 UART transmit data Default mapping: eUSCI_A3 SPI slave in, master out LCD segment output S30
P4.3/PM_UCA3CLK/S29	62	I/O	General-purpose digital I/O with mappable secondary function Default mapping: eUSCI_A3 clock input/output LCD segment output S29
P4.4/PM_UCB1SOMI/ PM_UCB1SCL/S28	63	I/O	General-purpose digital I/O with mappable secondary function Default mapping: eUSCI_B1 SPI slave out, master in Default mapping: eUSCI_B1 I ² C clock LCD segment output S28
P4.5/PM_UCB1SIMO/ PM_UCB1SDA/S27	64	I/O	General-purpose digital I/O with mappable secondary function Default mapping: eUSCI_B1 SPI slave in, master out Default mapping: eUSCI_B1 I ² C data LCD segment output S27
P4.6/PM_UCB1CLK/S26	65	I/O	General-purpose digital I/O with mappable secondary function Default mapping: eUSCI_B1 clock input/output LCD segment output S26
P4.7/PM_TA3.0/S25	66	I/O	General-purpose digital I/O with mappable secondary function Default Mapping: Timer TA3 CCR0 capture: CCI0A input, compare: Out0 output LCD segment output S25
P5.0/SDCLK/S24	67	I/O	General-purpose digital I/O SD24_B bit stream clock input/output LCD segment output S24

Table 4-4. Terminal Functions – PZ Package (continued)

TERMINAL		I/O ⁽¹⁾	DESCRIPTION
NAME	NO. PZ		
P5.1/PM_SD0DIO/S23	68	I/O	General-purpose digital I/O Default mapping: SD24_B converter 0 bit stream data input/output LCD segment output S23
P5.2/PM_SD1DIO/S22	69	I/O	General-purpose digital I/O Default mapping: SD24_B converter 1 bit stream data input/output LCD segment output S22
P5.3/PM_SD2DIO/S21	70	I/O	General-purpose digital I/O Default mapping: SD24_B converter 2 bit stream data input/output LCD segment output S21
P5.4/PM_SD3DIO/S20	71	I/O	General-purpose digital I/O Default mapping: SD24_B converter 3 bit stream data input/output LCD segment output S20
P5.5/PM_SD4DIO/S19	72	I/O	General-purpose digital I/O Default mapping: SD24_B converter 4 bit stream data input/output (not available on F674x devices) LCD segment output S19
P5.6/PM_SD5DIO/S18	73	I/O	General-purpose digital I/O Default mapping: SD24_B converter 5 bit stream data input/output (not available on F674x devices) LCD segment output S18
P5.7/PM_SD6DIO/S17	74	I/O	General-purpose digital I/O Default mapping: SD24_B converter 4 bit stream data input/output (not available on F676x, F674x devices) LCD segment output S17
VDSYS2 ⁽⁵⁾	75		Digital power supply for I/Os
DVSS2	76		Digital ground supply
P6.0/S16	77	I/O	General-purpose digital I/O LCD segment output S16
P6.1/S15	78	I/O	General-purpose digital I/O LCD segment output S15
P6.2/S14	79	I/O	General-purpose digital I/O LCD segment output S14
P6.3/S13	80	I/O	General-purpose digital I/O LCD segment output S13
P6.4/S12	81	I/O	General-purpose digital I/O LCD segment output S12
P6.5/S11	82	I/O	General-purpose digital I/O LCD segment output S11
P6.6/S10	83	I/O	General-purpose digital I/O LCD segment output S10
P6.7/S9	84	I/O	General-purpose digital I/O LCD segment output S9

(5) The pins VDSYS1 and VDSYS2 must be connected externally on board for proper device operation.

Table 4-4. Terminal Functions – PZ Package (continued)

TERMINAL		I/O ⁽¹⁾	DESCRIPTION
NAME	NO. PZ		
P7.0/S8	85	I/O	General-purpose digital I/O LCD segment output S8
P7.1/S7	86	I/O	General-purpose digital I/O LCD segment output S7
P7.2/S6	87	I/O	General-purpose digital I/O LCD segment output S6
P7.3/S5	88	I/O	General-purpose digital I/O LCD segment output S5
P7.4/S4	89	I/O	General-purpose digital I/O LCD segment output S4
P7.5/S3	90	I/O	General-purpose digital I/O LCD segment output S3
P7.6/S2	91	I/O	General-purpose digital I/O LCD segment output S2
P7.7/S1	92	I/O	General-purpose digital I/O LCD segment output S1
P8.0/S0	93	I/O	General-purpose digital I/O LCD segment output S0
P8.1/TACLK/RTCCLK/CB3	94	I/O	General-purpose digital I/O Timer clock input TACLK for TA0, TA1, TA2, TA3 RTCCLK clock output Comparator_B input CB3
TEST/SBWTK	95	I	Test mode pin – select digital I/O on JTAG pins Spy-By-Wire input clock
PJ.0/TDO	96	I/O	General-purpose digital I/O Test data output
PJ.1/TDI/TCLK	97	I/O	General-purpose digital I/O Test data input or Test clock input
PJ.2/TMS	98	I/O	General-purpose digital I/O Test mode select
PJ.3/TCK	99	I/O	General-purpose digital I/O Test clock
$\overline{\text{RST}}/\text{NMI}/\text{SBWTDIO}$	100	I/O	Reset input, active low ⁽⁶⁾ Nonmaskable interrupt input Spy-By-Wire data input/output

(6) When this pin is configured as reset, the internal pullup resistor is enabled by default.

5 Specifications

All graphs in this section are for typical conditions, unless otherwise noted.

Typical (TYP) values are specified at $V_{CC} = 3.3\text{ V}$ and $T_A = 25^\circ\text{C}$, unless otherwise noted.

5.1 Absolute Maximum Ratings

over operating free-air temperature range (unless otherwise noted)⁽¹⁾

		MIN	MAX	UNIT
Voltage applied at DVCC to DVSS		-0.3	4.1	V
Voltage applied to pins ⁽²⁾	All pins except V _{CORE} , SD24_B input pins (SDxN0, SDxP0) ⁽³⁾ , AUXVCC1, AUXVCC2, and AUXVCC3 ⁽⁴⁾	-0.3	$V_{CC} + 0.3$	V
Diode current at pins	All pins except SD24_B input pins (SDxN0, SDxP0)		±2	mA
	SD0N0, SD0P0, SD1N0, SD1P0, SD2N0, SD2P0, SD3N0, SD3P0, SD4N0, SD4P0, SD5N0, SD5P0, SD6N0, SD6P0 ⁽⁵⁾		2	
Maximum junction temperature, T _J			95	°C
Storage temperature, T _{stg} ⁽⁶⁾		-55	105	°C

- (1) Stresses beyond those listed under *Absolute Maximum Ratings* may cause permanent damage to the device. These are stress ratings only, and functional operation of the device at these or any other conditions beyond those indicated under *Recommended Operating Conditions* is not implied. Exposure to absolute-maximum-rated conditions for extended periods may affect device reliability.
- (2) All voltages referenced to $V_{SS} = V_{DVSS} = V_{AVSS}$.
- (3) See [Section 5.48](#) for SD24_B specifications.
- (4) See [Section 5.27](#) for AUX specifications.
- (5) A protection diode is connected to V_{CC} for the SD24_B input pins. No protection diode is connected to V_{SS} .
- (6) Higher temperature may be applied during board soldering according to the current JEDEC J-STD-020 specification with peak reflow temperatures not higher than classified on the device label on the shipping boxes or reels.

5.2 ESD Ratings

		VALUE	UNIT
V _(ESD) Electrostatic discharge	Human-body model (HBM), per ANSI/ESDA/JEDEC JS-001 ⁽¹⁾	±1000	V
	Charged-device model (CDM), per JEDEC specification JESD22-C101 ⁽²⁾	±250	

- (1) JEDEC document JEP155 states that 500-V HBM allows safe manufacturing with a standard ESD control process. Pins listed as ±1000 V may actually have higher performance.
- (2) JEDEC document JEP157 states that 250-V CDM allows safe manufacturing with a standard ESD control process. Pins listed as ±250 V may actually have higher performance.

5.3 Recommended Operating Conditions

		MIN	NOM	MAX	UNIT
V _{CC}	Supply voltage during program execution and flash programming. $V_{AVCC} = V_{DVCC} = V_{CC}$ ⁽¹⁾⁽²⁾	PMMCOREVx = 0	1.8	3.6	V
		PMMCOREVx = 0, 1	2.0	3.6	
		PMMCOREVx = 0, 1, 2	2.2	3.6	
		PMMCOREVx = 0, 1, 2, 3	2.4	3.6	
V _{SS}	Supply voltage $V_{AVSS} = V_{DVSS} = V_{SS}$		0		V
T _A	Operating free-air temperature	I version	-40	85	°C
T _J	Operating junction temperature	I version	-40	85	°C
C _{VCORE}	Recommended capacitor at V _{CORE} ⁽³⁾		470		nF
$\frac{C_{DVCC}}{C_{VCORE}}$	Capacitor ratio of DVCC to V _{CORE}		10		

- (1) TI recommends powering AVCC and DVCC from the same source. A maximum difference of 0.3 V between V_{AVCC} and V_{DVCC} can be tolerated during power up and operation.
- (2) The minimum supply voltage is defined by the supervisor SVS levels when it is enabled. See the threshold parameters in [Section 5.22](#) for the exact values and more details.
- (3) A capacitor tolerance of ±20% or better is required.

Recommended Operating Conditions (continued)

		MIN	NOM	MAX	UNIT	
f _{SYSTEM}	Processor frequency (maximum MCLK frequency) ⁽⁴⁾ ⁽⁵⁾ (see Figure 5-1)	PMMCOREVx = 0, 1.8 V ≤ V _{CC} ≤ 3.6 V (default condition)		0	8.0	MHz
		PMMCOREVx = 1, 2 V ≤ V _{CC} ≤ 3.6 V		0	12.0	
		PMMCOREVx = 2, 2.2 V ≤ V _{CC} ≤ 3.6 V		0	20.0	
		PMMCOREVx = 3, 2.4 V ≤ V _{CC} ≤ 3.6 V		0	25.0	
I _{LOAD, DVCCD}	Maximum load current that can be drawn from DVCC for core and IO (I _{LOAD} = I _{CORE} + I _{IO})			20	mA	
I _{LOAD, AUX1D}	Maximum load current that can be drawn from AUXVCC1 for core and IO (I _{LOAD} = I _{CORE} + I _{IO})			20	mA	
I _{LOAD, AUX2D}	Maximum load current that can be drawn from AUXVCC2 for core and IO (I _{LOAD} = I _{CORE} + I _{IO})			20	mA	
I _{LOAD, AVCCA}	Maximum load current that can be drawn from AVCC for analog modules (I _{LOAD} = I _{Modules})			10	mA	
I _{LOAD, AUX1A}	Maximum load current that can be drawn from AUXVCC1 for analog modules (I _{LOAD} = I _{Modules})			5	mA	
I _{LOAD, AUX2A}	Maximum load current that can be drawn from AUXVCC2 for analog modules (I _{LOAD} = I _{Modules})			5	mA	
P _{INT}	Internal power dissipation			V _{CC} × I _{DVCC}	W	
P _{IO}	I/O power dissipation of the I/O pins powered by DVCC			(V _{CC} - V _{IOH}) × I _{IOH} + V _{IOL} × I _{IOL}	W	
P _{MAX}	Maximum allowed power dissipation, P _{MAX} > P _{IO} + P _{INT}			(T _J - T _A)/θ _{JA}	W	

- (4) The MSP430 CPU is clocked directly with MCLK. Both the high and low phases of MCLK must not exceed the pulse duration of the specified maximum frequency.
- (5) Modules may have a different maximum input clock specification. See the specification of the respective module in this data sheet.

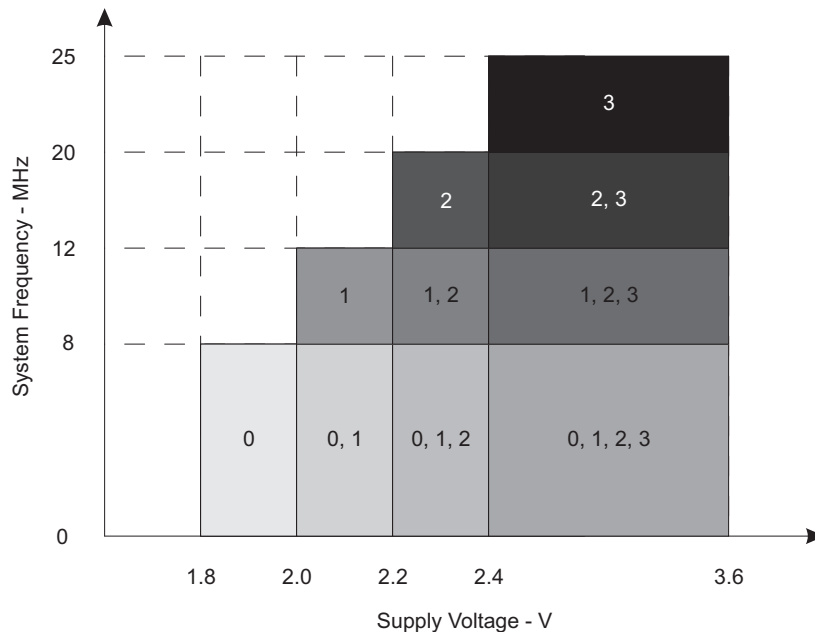

The numbers within the fields denote the supported PMMCOREVx settings.

Figure 5-1. Maximum System Frequency

5.4 Active Mode Supply Current Into V_{CC} Excluding External Current

over recommended operating free-air temperature (unless otherwise noted)⁽¹⁾⁽²⁾⁽³⁾

PARAMETER	EXECUTION MEMORY	V_{CC}	PMM COREV _x	FREQUENCY ($f_{DCO} = f_{MCLK} = f_{SMCLK}$)								UNIT		
				1 MHz		8 MHz		12 MHz		20 MHz			25 MHz	
				TYP	MAX	TYP	MAX	TYP	MAX	TYP	MAX		TYP	MAX
$I_{AM, Flash}^{(4)}$	Flash	3 V	0	0.32	0.50	2.08	2.84							mA
			1	0.35		2.35		3.50	4.76					
			2	0.39		2.68		3.99		6.61	8.3			
			3	0.41		2.83		4.22		6.98		8.67	11.75	
$I_{AM, RAM}^{(5)}$	RAM	3 V	0	0.19		1.04							mA	
			1	0.21		1.20		1.77						
			2	0.23		1.38		2.04		3.35				
			3	0.24		1.47		2.18		3.58		4.44		

- (1) All inputs are tied to 0 V or to V_{CC} . Outputs do not source or sink any current.
- (2) The currents are characterized with a Micro Crystal MS1V-T1K crystal with a load capacitance of 12.5 pF. The internal and external load capacitance are chosen to closely match the required 12.5 pF.
- (3) Characterized with program executing typical data processing.
 $f_{ACLK} = 32786$ Hz, $f_{DCO} = f_{MCLK} = f_{SMCLK}$ at specified frequency.
 $XTS = CPUOFF = SCG0 = SCG1 = OSCOFF = SMCLKOFF = 0$.
- (4) Active mode supply current when program executes in flash at a nominal supply voltage of 3 V.
- (5) Active mode supply current when program executes in RAM at a nominal supply voltage of 3 V.

5.5 Low-Power Mode Supply Currents (Into V_{CC}) Excluding External Current

over recommended ranges of supply voltage and operating free-air temperature (unless otherwise noted)⁽¹⁾⁽²⁾

PARAMETER	V_{CC}	PMMCOREVx	TEMPERATURE (T_A)						UNIT
			–40°C		25°C		85°C		
			TYP	MAX	TYP	MAX	TYP	MAX	
$I_{LPM0,1MHz}$ Low-power mode 0 ^{(3) (4)}	2.2 V	0	70		75		86	μA	
	3 V	3	81		87	105	100 130		
I_{LPM2} Low-power mode 2 ^{(5) (4)}	2.2 V	0	5.9		6.5		12.5	μA	
	3 V	3	6.7		7.3	18	13.8 30		
$I_{LPM3,XT1LF}$ Low-power mode 3, crystal mode ^{(6) (4)}	2.2 V	0	1.50		2.0		7.8	μA	
		1	1.65		2.2		8.3		
		2	1.80		2.4		8.6		
		3	1.84		2.4		8.6		
$I_{LPM3,XT1LF}$ Low-power mode 3, crystal mode ^{(6) (4)}	3 V	0	2.0		2.5		8.5	μA	
		1	2.1		2.7		9.0		
		2	2.3		2.9		9.3		
		3	2.3		2.9		9.3 25		
$I_{LPM3,VLO}$ Low-power mode 3, VLO mode ^{(7) (4)}	3 V	0	1.3		1.7		7.5	μA	
		1	1.3		1.8		7.9		
		2	1.4		1.9		8.2		
		3	1.4		1.9		8.2 25.0		
I_{LPM4} Low-power mode 4 ^{(8) (4)}	3 V	0	1.2		1.6		7.4	μA	
		1	1.2		1.7		7.8		
		2	1.3		1.7		7.9		
		3	1.3		1.7		8.0 23.0		
$I_{LPM3.5}$ Low-power mode 3.5, RTC active on AUXVCC3 ⁽⁹⁾	2.2 V		0.7		0.9		1.4	μA	
	3 V		1.0		1.2	1.5	1.8 3.0		
$I_{LPM4.5}$ Low-power mode 4.5 ⁽¹⁰⁾	3 V		0.6		0.7	1.0	1.2 2.0	μA	

(1) All inputs are tied to 0 V or to V_{CC} . Outputs do not source or sink any current.

(2) The currents are characterized with a Micro Crystal MS1V-T1K crystal with a load capacitance of 12.5 pF. The internal and external load capacitance are chosen to closely match the required 12.5 pF.

(3) Current for watchdog timer clocked by SMCLK included. ACLK = low-frequency crystal operation (XTS = 0, XT1DRIVE_x = 0).

CPUOFF = 1, SCG0 = 0, SCG1 = 0, OSCOFF = 0 (LPM0), f_{ACLK} = 32768 Hz, f_{MCLK} = 0 MHz, f_{SMCLK} = f_{DCO} = 1 MHz

(4) Current for brownout and high-side supervisor (SVSH) normal mode included. Low-side supervisor (SVSL) and low-side monitor (SVM_L) disabled. High-side monitor (SVM_H) disabled. RAM retention enabled.

(5) Current for watchdog timer and RTC clocked by ACLK included. ACLK = low-frequency crystal operation (XTS = 0, XT1DRIVE_x = 0).

CPUOFF = 1, SCG0 = 0, SCG1 = 1, OSCOFF = 0 (LPM2), f_{ACLK} = 32768 Hz, f_{MCLK} = 0 MHz, f_{SMCLK} = f_{DCO} = 0 MHz, DCO setting = 1 MHz operation, DCO bias generator enabled.

(6) Current for watchdog timer and RTC clocked by low-frequency clock included. ACLK = low-frequency crystal operation (XTS = 0, XT1DRIVE_x = 0).

CPUOFF = 1, SCG0 = 1, SCG1 = 1, OSCOFF = 0 (LPM3), f_{ACLK} = 32768 Hz, f_{MCLK} = f_{SMCLK} = f_{DCO} = 0 MHz

(7) Current for watchdog timer and RTC clocked by low-frequency clock included. ACLK = VLO.

CPUOFF = 1, SCG0 = 1, SCG1 = 1, OSCOFF = 0 (LPM3), f_{ACLK} = f_{VLO} , f_{MCLK} = f_{SMCLK} = f_{DCO} = 0 MHz

CPUOFF = 1, SCG0 = 1, SCG1 = 1, OSCOFF = 1 (LPM4), f_{DCO} = f_{ACLK} = f_{MCLK} = f_{SMCLK} = 0 MHz

(9) f_{DCO} = f_{MCLK} = f_{SMCLK} = 0 MHz, f_{ACLK} = 32768 Hz, PMMREGOFF = 1, RTC active on AUXVCC3 supply

(10) f_{DCO} = f_{MCLK} = f_{SMCLK} = 0 MHz, f_{ACLK} = 0 Hz, PMMREGOFF = 1

5.6 Low-Power Mode With LCD Supply Currents (Into V_{CC}) Excluding External Current

over recommended ranges of supply voltage and operating free-air temperature (unless otherwise noted)⁽¹⁾⁽²⁾

PARAMETER	V_{CC}	PMMCOREVx	TEMPERATURE (T_A)						UNIT
			-40°C		25°C		85°C		
			TYP	MAX	TYP	MAX	TYP	MAX	
I_{LPM3} LCD, ext. bias	3 V	0	2.5		3.1		9.1	μA	
		1	2.6		3.3		9.5		
		2	2.8		3.5		9.9		
		3	2.8		3.5	6.0	10.0 25.0		
I_{LPM3} LCD, int. bias	3 V	0	2.9		3.5		9.7	μA	
		1	3.1		3.7		10.1		
		2	3.2		4.0		10.5		
		3	3.3		4.0	5.5	10.5 25.0		
I_{LPM3} LCD,CP	2.2 V	0	2.2		2.8		8.8	μA	
		1	2.3		3.0		9.1		
		2	2.5		3.2		9.5		
	3 V	0	2.6		3.2		9.3		
		1	2.8		3.4		9.7		
		2	2.9		3.6		10.1		
		3	3.0		3.7		10.2		

- (1) All inputs are tied to 0 V or to V_{CC} . Outputs do not source or sink any current.
- (2) The currents are characterized with a Micro Crystal MS1V-T1K crystal with a load capacitance of 12.5 pF. The internal and external load capacitance are chosen to closely match the required 12.5 pF.
- (3) Current for watchdog timer and RTC clocked by ACLK included. ACLK = low-frequency crystal operation (XTS = 0, XT1DRIVE_x = 0). CPUOFF = 1, SCG0 = 1, SCG1 = 1, OSCOFF = 0 (LPM3), f_{ACLK} = 32768 Hz, f_{MCLK} = f_{SMCLK} = f_{DCO} = 0 MHz. Current for brownout, high-side supervisor (SVSH) normal mode included. Low-side supervisor and monitors disabled (SVSL, SVM_L). High-side monitor (SVM_H) disabled. RAM retention enabled.
- (4) LCDM_x = 11 (4-mux mode), LCDREXT = 1, LCDEXTBIAS = 1 (external biasing), LCD2B = 0 (1/3 bias), LCDPEN = 0 (charge pump disabled), LCDSSEL = 0, LCDPRE_x = 101, LCDDIV_x = 00011 (f_{LCD} = 32768 Hz / 32 / 4 = 256 Hz). Current through external resistors not included (voltage levels are supplied by test equipment). Even segments S0, S2, ... = 0, odd segments S1, S3, ... = 1. No LCD panel load.
- (5) LCDM_x = 11 (4-mux mode), LCDREXT = 0, LCDEXTBIAS = 0 (internal biasing), LCD2B = 0 (1/3 bias), LCDPEN = 0 (charge pump disabled), LCDSSEL = 0, LCDPRE_x = 101, LCDDIV_x = 00011 (f_{LCD} = 32768 Hz / 32 / 4 = 256 Hz). Even segments S0, S2, ... = 0, odd segments S1, S3, ... = 1. No LCD panel load.
- (6) LCDM_x = 11 (4-mux mode), LCDREXT = 0, LCDEXTBIAS = 0 (internal biasing), LCD2B = 0 (1/3 bias), LCDPEN = 1 (charge pump enabled), VLCD_x = 1000 (V_{LCD} = 3 V, typical), LCDSSEL = 0, LCDPRE_x = 101, LCDDIV_x = 00011 (f_{LCD} = 32768 Hz / 32 / 4 = 256 Hz). Even segments S0, S2, ... = 0, odd segments S1, S3, ... = 1. No LCD panel load.

5.7 Thermal Packaging Characteristics

THERMAL METRIC ^{(1) (2)}			VALUE	UNIT
R _{θJA}	Junction-to-ambient thermal resistance, still air	LQFP 128 (PEU)	44.4	°C/W
		LQFP 100 (PZ)	42.9	
R _{θJC(TOP)}	Junction-to-case (top) thermal resistance	LQFP 128 (PEU)	10.5	°C/W
		LQFP 100 (PZ)	9.3	
R _{θJC(BOTTOM)}	Junction-to-case (bottom) thermal resistance	LQFP 128 (PEU)	N/A ⁽³⁾	°C/W
		LQFP 100 (PZ)	N/A	
R _{θJB}	Junction-to-board thermal resistance	LQFP 128 (PEU)	23.1	°C/W
		LQFP 100 (PZ)	20.6	
Ψ _{JT}	Junction-to-package-top thermal characterization parameter	LQFP 128 (PEU)	0.4	°C/W
		LQFP 100 (PZ)	0.3	
Ψ _{JB}	Junction-to-board thermal characterization parameter	LQFP 128 (PEU)	22.8	°C/W
		LQFP 100 (PZ)	20.3	

- (1) For more information about traditional and new thermal metrics, see [Semiconductor and IC Package Thermal Metrics](#).
- (2) These values are based on a JEDEC-defined 2S2P system (with the exception of the Theta JC [R_{θJC}] value, which is based on a JEDEC-defined 1S0P system) and will change based on environment as well as application. For more information, see these EIA/JEDEC standards:
- JESD51-2, *Integrated Circuits Thermal Test Method Environmental Conditions - Natural Convection (Still Air)*
 - JESD51-3, *Low Effective Thermal Conductivity Test Board for Leaded Surface Mount Packages*
 - JESD51-7, *High Effective Thermal Conductivity Test Board for Leaded Surface Mount Packages*
 - JESD51-9, *Test Boards for Area Array Surface Mount Package Thermal Measurements*
- (3) N/A = not applicable

5.8 Schmitt-Trigger Inputs – General-Purpose I/O

over recommended ranges of supply voltage and operating free-air temperature (unless otherwise noted)

PARAMETER		TEST CONDITIONS	V _{CC}	MIN	TYP	MAX	UNIT
V _{IT+}	Positive-going input threshold voltage		1.8 V	0.80		1.40	V
			3 V	1.50		2.10	
V _{IT-}	Negative-going input threshold voltage		1.8 V	0.45		1.00	V
			3 V	0.75		1.65	
V _{hys}	Input voltage hysteresis (V _{IT+} – V _{IT-})		1.8 V	0.3		0.85	V
			3 V	0.4		1.0	
R _{Pull}	Pullup or pulldown resistor ⁽¹⁾	For pullup: V _{IN} = V _{SS} , For pulldown: V _{IN} = V _{CC}		20	35	50	kΩ
C _I	Input capacitance	V _{IN} = V _{SS} or V _{CC}			5		pF

(1) Also applies to $\overline{\text{RST}}$ pin when pullup or pulldown resistor is enabled.

5.9 Inputs – Ports P1 and P2⁽¹⁾

over recommended ranges of supply voltage and operating free-air temperature (unless otherwise noted)

PARAMETER	TEST CONDITIONS	V _{CC}	MIN	MAX	UNIT
t _(int)	External interrupt timing ⁽²⁾	Port P1 and P2: P1.x to P2.x, external trigger pulse duration to set interrupt flag	2.2 V, 3 V	20	ns

(1) Some devices may contain additional ports with interrupts. See the block diagram and terminal function descriptions.

(2) An external signal sets the interrupt flag every time the minimum interrupt pulse duration t_(int) is met. It may be set by trigger signals shorter than t_(int).

5.10 Leakage Current – General-Purpose I/O

over recommended ranges of supply voltage and operating free-air temperature (unless otherwise noted)

PARAMETER	TEST CONDITIONS	V _{CC}	MIN	MAX	UNIT	
I _{lkg(Px.y)}	High-impedance leakage current	See ⁽¹⁾ (²)	1.8 V, 3 V	-50	+50	nA

(1) The leakage current is measured with V_{SS} or V_{CC} applied to the corresponding pins, unless otherwise noted.

(2) The leakage of the digital port pins is measured individually. The port pin is selected for input and the pullup or pulldown resistor is disabled.

5.11 Outputs – General-Purpose I/O (Full Drive Strength)

over recommended ranges of supply voltage and operating free-air temperature (unless otherwise noted) (also see [Figure 5-6](#) through [Figure 5-9](#))

PARAMETER		TEST CONDITIONS	V _{CC}	MIN	MAX	UNIT
V _{OH}	High-level output voltage	I _(OHmax) = -3 mA ⁽¹⁾	1.8 V	1.55	1.80	V
		I _(OHmax) = -10 mA ⁽¹⁾		1.20	1.80	
		I _(OHmax) = -5 mA ⁽¹⁾	3 V	2.75	3.00	
		I _(OHmax) = -15 mA ⁽¹⁾		2.40	3.00	
V _{OL}	Low-level output voltage	I _(OLmax) = 3 mA ⁽²⁾	1.8 V	0.00	0.25	V
		I _(OLmax) = 10 mA ⁽³⁾		0.00	0.60	
		I _(OLmax) = 5 mA ⁽²⁾	3 V	0.00	0.25	
		I _(OLmax) = 15 mA ⁽³⁾		0.00	0.60	

- (1) The maximum total current, I_(OHmax), for all outputs combined should not exceed ±20 mA to hold the maximum voltage drop specified. See [Section 5.3](#) for more details.
- (2) The maximum total current, I_(OLmax), for all outputs combined should not exceed ±48 mA to hold the maximum voltage drop specified.
- (3) The maximum total current, I_(OLmax), for all outputs combined should not exceed ±100 mA to hold the maximum voltage drop specified.

5.12 Outputs – General-Purpose I/O (Reduced Drive Strength)

over recommended ranges of supply voltage and operating free-air temperature (unless otherwise noted)⁽¹⁾ (also see [Figure 5-2](#) through [Figure 5-5](#))

PARAMETER		TEST CONDITIONS	V _{CC}	MIN	MAX	UNIT
V _{OH}	High-level output voltage	I _(OHmax) = -1 mA ⁽²⁾	1.8 V	1.55	1.80	V
		I _(OHmax) = -3 mA ⁽²⁾		1.20	1.80	
		I _(OHmax) = -2 mA ⁽²⁾	3 V	2.75	3.00	
		I _(OHmax) = -6 mA ⁽²⁾		2.40	3.00	
V _{OL}	Low-level output voltage	I _(OLmax) = 1 mA ⁽³⁾	1.8 V	0.00	0.25	V
		I _(OLmax) = 3 mA ⁽⁴⁾		0.00	0.60	
		I _(OLmax) = 2 mA ⁽³⁾	3 V	0.00	0.25	
		I _(OLmax) = 6 mA ⁽⁴⁾		0.00	0.60	

- (1) Selecting reduced drive strength may reduce EMI.
- (2) The maximum total current, I_(OHmax), for all outputs combined should not exceed ±20 mA to hold the maximum voltage drop specified. See [Section 5.3](#) for more details.
- (3) The maximum total current, I_(OLmax), for all outputs combined, should not exceed ±48 mA to hold the maximum voltage drop specified.
- (4) The maximum total current, I_(OLmax), for all outputs combined, should not exceed ±100 mA to hold the maximum voltage drop specified.

5.13 Output Frequency – General-Purpose I/O

over recommended ranges of supply voltage and operating free-air temperature (unless otherwise noted)

PARAMETER		TEST CONDITIONS	MIN	MAX	UNIT
f _{Px,y}	Port output frequency (with load)	See ⁽¹⁾ ⁽²⁾	V _{CC} = 1.8 V, PMMCOREV _x = 0	16	MHz
			V _{CC} = 3 V, PMMCOREV _x = 3	25	
f _{Port_CLK}	Clock output frequency	ACLK, SMCLK, or MCLK, C _L = 20 pF ⁽²⁾	V _{CC} = 1.8 V, PMMCOREV _x = 0	16	MHz
			V _{CC} = 3 V, PMMCOREV _x = 3	25	

- (1) A resistive divider with 2 × R₁ between V_{CC} and V_{SS} is used as load. The output is connected to the center tap of the divider. For full drive strength, R₁ = 550 Ω. For reduced drive strength, R₁ = 1.6 kΩ. C_L = 20 pF is connected to the output to V_{SS}.
- (2) The output voltage reaches at least 10% and 90% V_{CC} at the specified toggle frequency.

5.14 Typical Characteristics – Outputs, Reduced Drive Strength (PxDS.y = 0)

over recommended ranges of supply voltage and operating free-air temperature (unless otherwise noted)

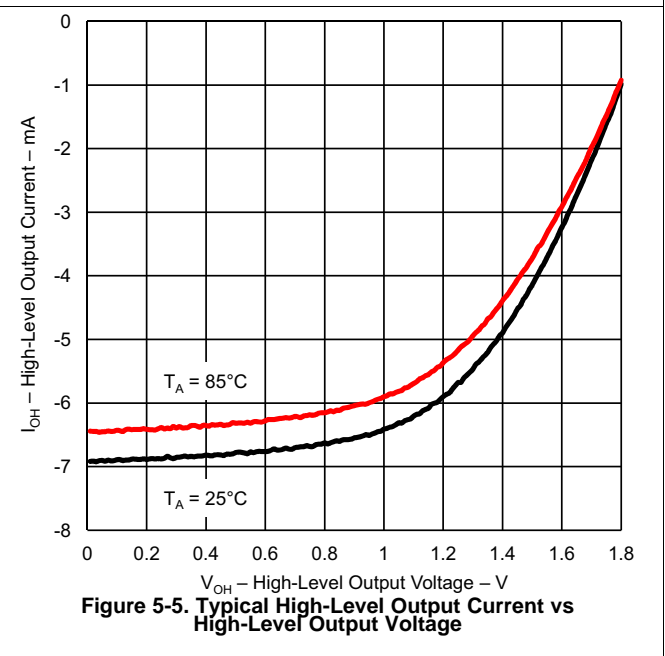
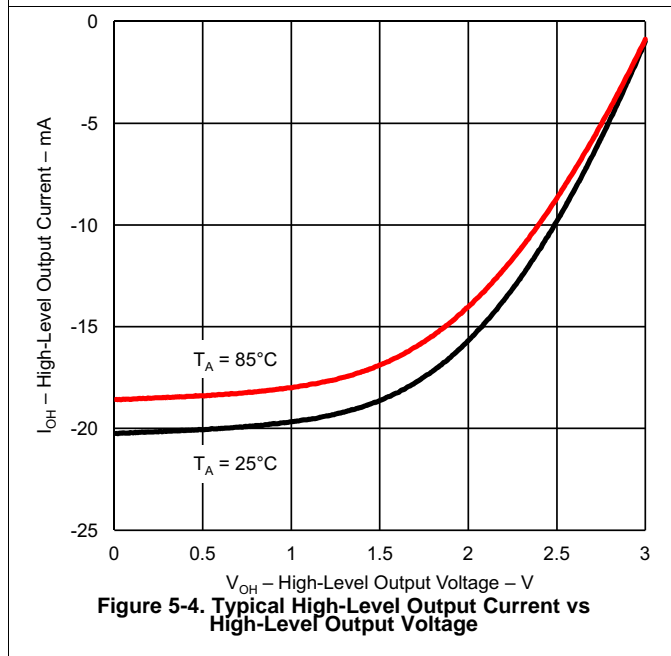
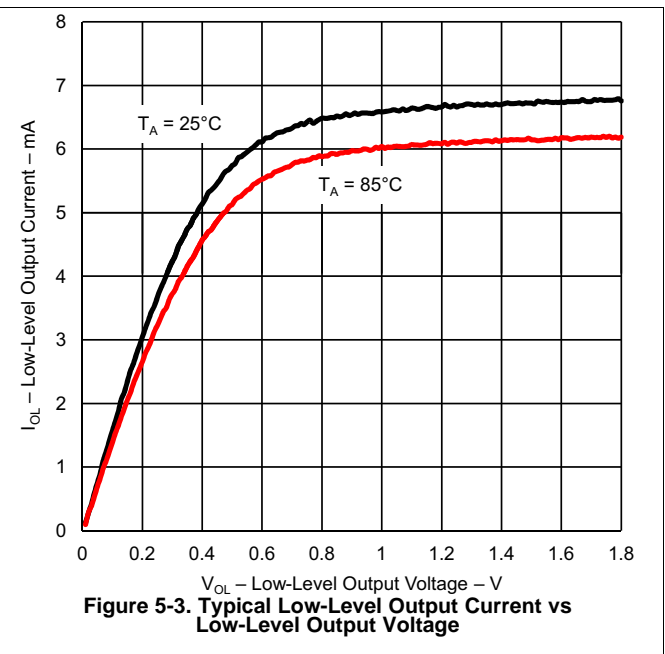
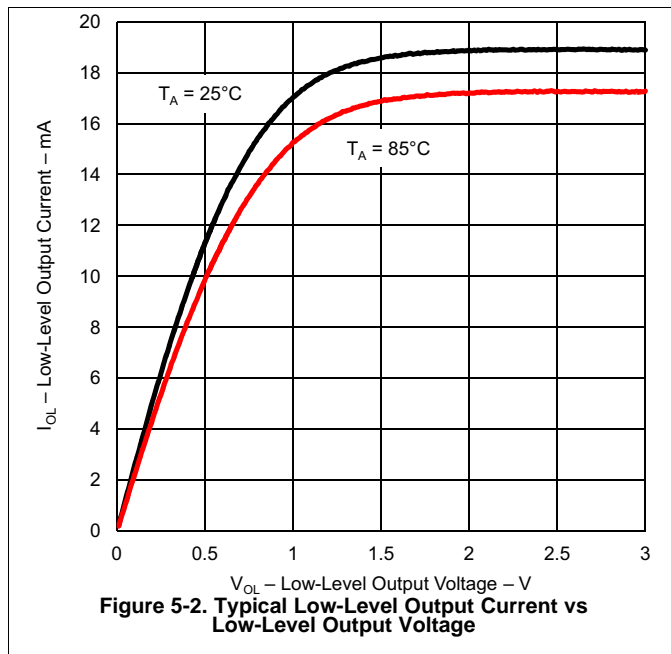

5.15 Typical Characteristics – Outputs, Full Drive Strength (PxDS.y = 1)

over recommended ranges of supply voltage and operating free-air temperature (unless otherwise noted)

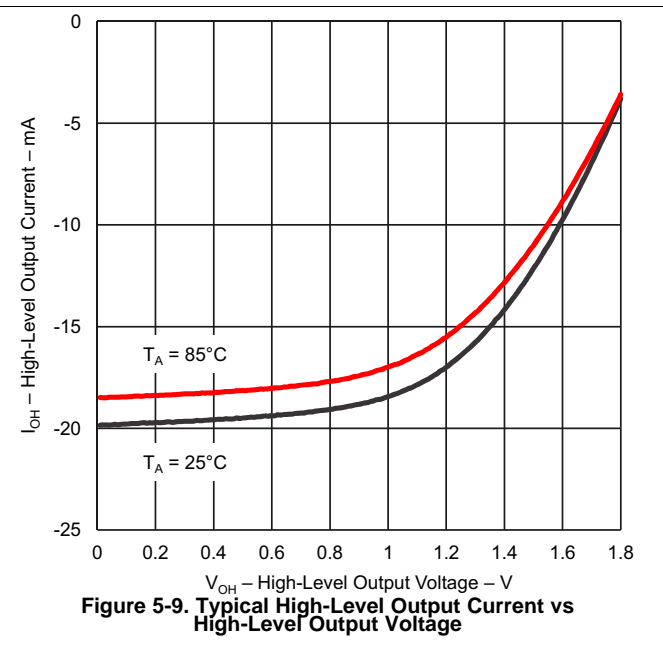
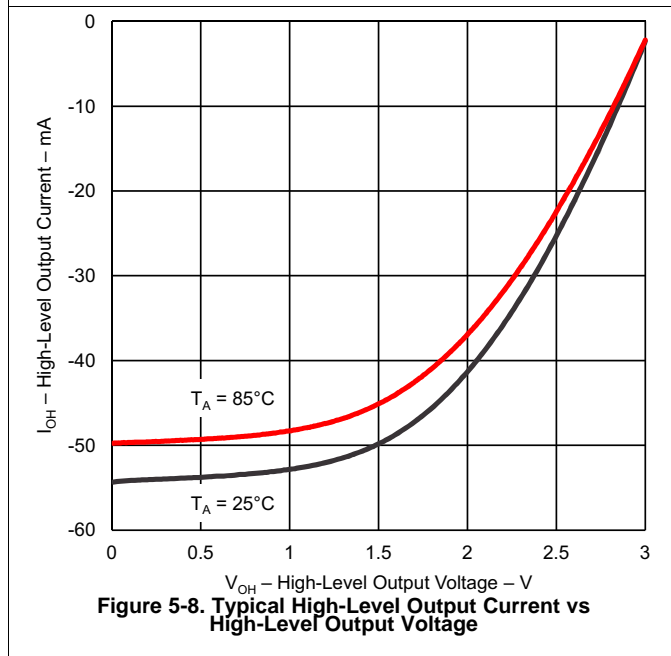
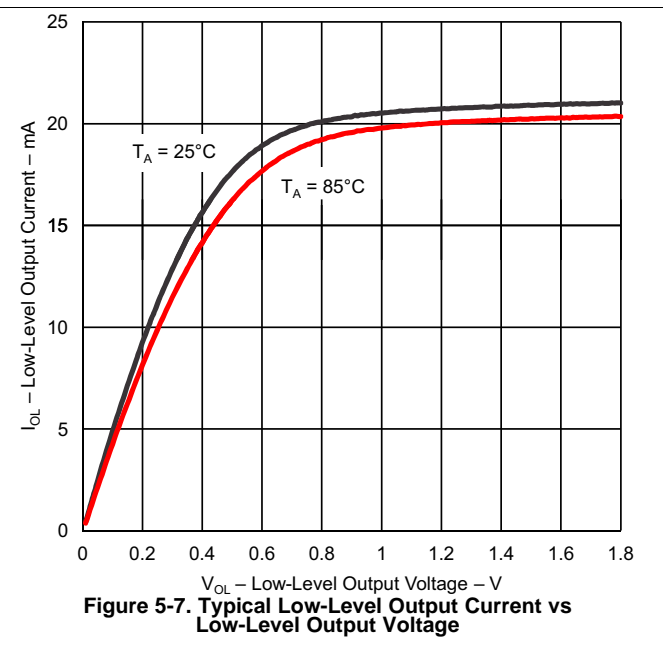
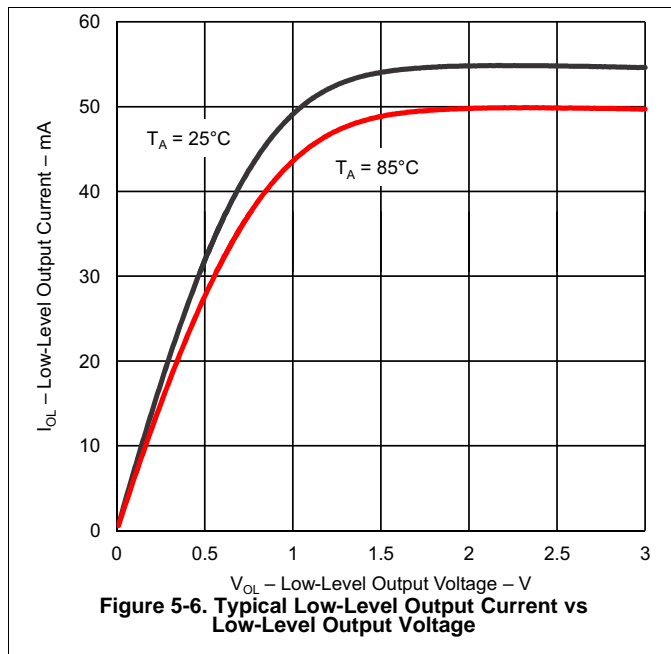

5.16 Crystal Oscillator, XT1, Low-Frequency Mode⁽¹⁾

over recommended ranges of supply voltage and operating free-air temperature (unless otherwise noted)

PARAMETER	TEST CONDITIONS	V _{CC}	MIN	TYP	MAX	UNIT
$\Delta I_{DVCC,LF}$	Differential XT1 oscillator crystal current consumption from lowest drive setting, LF mode	3 V		0.075		μA
	$f_{OSC} = 32768$ Hz, XTS = 0, XT1BYPASS = 0, XT1DRIVE _x = 1, T _A = 25°C					
	$f_{OSC} = 32768$ Hz, XTS = 0, XT1BYPASS = 0, XT1DRIVE _x = 2, T _A = 25°C					
	$f_{OSC} = 32768$ Hz, XTS = 0, XT1BYPASS = 0, XT1DRIVE _x = 3, T _A = 25°C			0.290		
$f_{XT1,LF0}$	XT1 oscillator crystal frequency, LF mode			32768		Hz
$f_{XT1,LF,SW}$	XT1 oscillator logic-level square-wave input frequency, LF mode		10	32.768	50	kHz
OA_{LF}	Oscillation allowance for LF crystals ⁽⁴⁾			210		k Ω
				$f_{XT1,LF} = 32768$ Hz, C _{L,eff} = 6 pF		
$C_{L,eff}$	Integrated effective load capacitance, LF mode ⁽⁵⁾			1		pF
				XTS = 0, XCAP _x = 1		
				XTS = 0, XCAP _x = 2		
				XTS = 0, XCAP _x = 3		
	Duty cycle, LF mode		30%		70%	
$f_{Fault,LF}$	Oscillator fault frequency, LF mode ⁽⁷⁾		10		10000	Hz
$t_{START,LF}$	Start-up time, LF mode	3 V		1000		ms
				$f_{OSC} = 32768$ Hz, XTS = 0, XT1BYPASS = 0, XT1DRIVE _x = 0, T _A = 25°C, C _{L,eff} = 6 pF		
	$f_{OSC} = 32768$ Hz, XTS = 0, XT1BYPASS = 0, XT1DRIVE _x = 3, T _A = 25°C, C _{L,eff} = 12 pF			500		

- (1) To improve EMI on the XT1 oscillator, the following guidelines should be observed.
 - Keep the trace between the device and the crystal as short as possible.
 - Design a good ground plane around the oscillator pins.
 - Prevent crosstalk from other clock or data lines into oscillator pins XIN and XOUT.
 - Avoid running PCB traces underneath or adjacent to the XIN and XOUT pins.
 - Use assembly materials and processes that avoid any parasitic load on the oscillator XIN and XOUT pins.
 - If conformal coating is used, make sure that it does not induce capacitive or resistive leakage between the oscillator pins.
- (2) When XT1BYPASS is set, XT1 circuits are automatically powered down. Input signal is a digital square wave with parametrics defined in the Schmitt-trigger Inputs section of this data sheet.
- (3) Maximum frequency of operation of the entire device cannot be exceeded.
- (4) Oscillation allowance is based on a safety factor of 5 for recommended crystals. The oscillation allowance is a function of the XT1DRIVE_x settings and the effective load. In general, comparable oscillator allowance can be achieved based on the following guidelines, but should be evaluated based on the actual crystal selected for the application:
 - For XT1DRIVE_x = 0, C_{L,eff} ≤ 6 pF.
 - For XT1DRIVE_x = 1, 6 pF ≤ C_{L,eff} ≤ 9 pF.
 - For XT1DRIVE_x = 2, 6 pF ≤ C_{L,eff} ≤ 10 pF.
 - For XT1DRIVE_x = 3, C_{L,eff} ≥ 6 pF.
- (5) Includes parasitic bond and package capacitance (approximately 2 pF per pin). Because the PCB adds additional capacitance, verify the correct load by measuring the ACLK frequency. For a correct setup, the effective load capacitance should always match the specification of the used crystal.
- (6) Requires external capacitors at both terminals. Values are specified by crystal manufacturers.
- (7) Frequencies below the MIN specification set the fault flag. Frequencies above the MAX specification do not set the fault flag. Frequencies between the MIN and MAX might set the flag.
- (8) Measured with logic-level input frequency but also applies to operation with crystals.

5.17 Internal Very-Low-Power Low-Frequency Oscillator (VLO)

over recommended ranges of supply voltage and operating free-air temperature (unless otherwise noted)

PARAMETER		TEST CONDITIONS	V _{CC}	MIN	TYP	MAX	UNIT
f _{VLO}	VLO frequency	Measured at ACLK	1.8 V to 3.6 V	6	9.6	15	kHz
df _{VLO} /dT	VLO frequency temperature drift	Measured at ACLK	1.8 V to 3.6 V		0.5		%/°C
df _{VLO} /dV _{CC}	VLO frequency supply voltage drift	Measured at ACLK	1.8 V to 3.6 V		4		%/V
	Duty cycle	Measured at ACLK	1.8 V to 3.6 V	40%	50%	60%	

5.18 Internal Reference, Low-Frequency Oscillator (REFO)

over recommended ranges of supply voltage and operating free-air temperature (unless otherwise noted)

PARAMETER		TEST CONDITIONS	V _{CC}	MIN	TYP	MAX	UNIT
I _{REFO}	REFO oscillator current consumption	T _A = 25°C	1.8 V to 3.6 V		3		μA
f _{REFO}	REFO frequency calibrated	Measured at ACLK	1.8 V to 3.6 V		32768		Hz
	REFO absolute tolerance calibrated	Full temperature range	1.8 V to 3.6 V	-3.5%		+3.5%	
		T _A = 25°C	3 V		-1.5%		+1.5%
df _{REFO} /dT	REFO frequency temperature drift	Measured at ACLK	1.8 V to 3.6 V		0.01		%/°C
df _{REFO} /dV _{CC}	REFO frequency supply voltage drift	Measured at ACLK	1.8 V to 3.6 V		1.0		%/V
	Duty cycle	Measured at ACLK	1.8 V to 3.6 V	40%	50%	60%	
t _{START}	REFO start-up time	40%/60% duty cycle	1.8 V to 3.6 V		25		μs

5.19 DCO Frequency

over recommended ranges of supply voltage and operating free-air temperature (unless otherwise noted) (see [Figure 5-10](#))

PARAMETER		TEST CONDITIONS	MIN	TYP	MAX	UNIT
$f_{DCO(0,0)}$	DCO frequency (0, 0) ⁽¹⁾	DCORSELx = 0, DCOx = 0, MODx = 0	0.07		0.20	MHz
$f_{DCO(0,31)}$	DCO frequency (0, 31) ⁽¹⁾	DCORSELx = 0, DCOx = 31, MODx = 0	0.70		1.70	MHz
$f_{DCO(1,0)}$	DCO frequency (1, 0) ⁽¹⁾	DCORSELx = 1, DCOx = 0, MODx = 0	0.15		0.36	MHz
$f_{DCO(1,31)}$	DCO frequency (1, 31) ⁽¹⁾	DCORSELx = 1, DCOx = 31, MODx = 0	1.47		3.45	MHz
$f_{DCO(2,0)}$	DCO frequency (2, 0) ⁽¹⁾	DCORSELx = 2, DCOx = 0, MODx = 0	0.32		0.75	MHz
$f_{DCO(2,31)}$	DCO frequency (2, 31) ⁽¹⁾	DCORSELx = 2, DCOx = 31, MODx = 0	3.17		7.38	MHz
$f_{DCO(3,0)}$	DCO frequency (3, 0) ⁽¹⁾	DCORSELx = 3, DCOx = 0, MODx = 0	0.64		1.51	MHz
$f_{DCO(3,31)}$	DCO frequency (3, 31) ⁽¹⁾	DCORSELx = 3, DCOx = 31, MODx = 0	6.07		14.0	MHz
$f_{DCO(4,0)}$	DCO frequency (4, 0) ⁽¹⁾	DCORSELx = 4, DCOx = 0, MODx = 0	1.3		3.2	MHz
$f_{DCO(4,31)}$	DCO frequency (4, 31) ⁽¹⁾	DCORSELx = 4, DCOx = 31, MODx = 0	12.3		28.2	MHz
$f_{DCO(5,0)}$	DCO frequency (5, 0) ⁽¹⁾	DCORSELx = 5, DCOx = 0, MODx = 0	2.5		6.0	MHz
$f_{DCO(5,31)}$	DCO frequency (5, 31) ⁽¹⁾	DCORSELx = 5, DCOx = 31, MODx = 0	23.7		54.1	MHz
$f_{DCO(6,0)}$	DCO frequency (6, 0) ⁽¹⁾	DCORSELx = 6, DCOx = 0, MODx = 0	4.6		10.7	MHz
$f_{DCO(6,31)}$	DCO frequency (6, 31) ⁽¹⁾	DCORSELx = 6, DCOx = 31, MODx = 0	39.0		88.0	MHz
$f_{DCO(7,0)}$	DCO frequency (7, 0) ⁽¹⁾	DCORSELx = 7, DCOx = 0, MODx = 0	8.5		19.6	MHz
$f_{DCO(7,31)}$	DCO frequency (7, 31) ⁽¹⁾	DCORSELx = 7, DCOx = 31, MODx = 0	60		135	MHz
$S_{DCORSEL}$	Frequency step between range DCORSEL and DCORSEL + 1	$S_{RSEL} = f_{DCO(DCORSEL+1,DCO)} / f_{DCO(DCORSEL,DCO)}$	1.2		2.3	ratio
S_{DCO}	Frequency step between tap DCO and DCO + 1	$S_{DCO} = f_{DCO(DCORSEL,DCO+1)} / f_{DCO(DCORSEL,DCO)}$	1.02		1.12	ratio
	Duty cycle	Measured at SMCLK	40%	50%	60%	
df_{DCO}/dT	DCO frequency temperature drift	$f_{DCO} = 1 \text{ MHz}$		0.1		%/°C
df_{DCO}/dV_{CORE}	DCO frequency voltage drift	$f_{DCO} = 1 \text{ MHz}$		1.9		%/V

- (1) When selecting the proper DCO frequency range (DCORSELx), the target DCO frequency, f_{DCO} , should be set to reside within the range of $f_{DCO(n,0),MAX} \leq f_{DCO} \leq f_{DCO(n,31),MIN}$, where $f_{DCO(n,0),MAX}$ represents the maximum frequency specified for the DCO frequency, range n, tap 0 (DCOx = 0) and $f_{DCO(n,31),MIN}$ represents the minimum frequency specified for the DCO frequency, range n, tap 31 (DCOx = 31). This ensures that the target DCO frequency resides within the range selected. It should also be noted that if the actual f_{DCO} frequency for the selected range causes the FLL or the application to select tap 0 or 31, the DCO fault flag is set to report that the selected range is at its minimum or maximum tap setting.

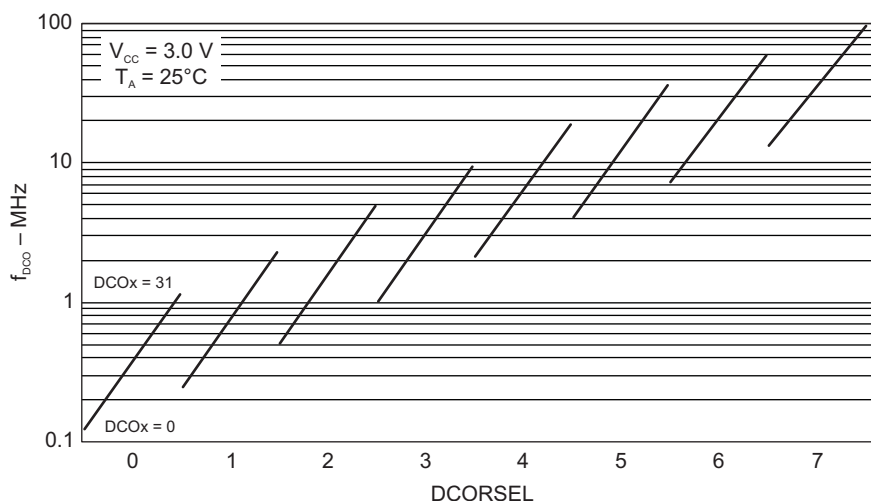

Figure 5-10. Typical DCO Frequency

5.20 PMM, Brownout Reset (BOR)

over recommended ranges of supply voltage and operating free-air temperature (unless otherwise noted)

PARAMETER		TEST CONDITIONS	MIN	TYP	MAX	UNIT
$V_{(DVCC_BOR_IT-)}$	BOR _H on voltage, DV _{CC} falling level	$ dDV_{CC}/dt < 3 \text{ V/s}$			1.45	V
$V_{(DVCC_BOR_IT+)}$	BOR _H off voltage, DV _{CC} rising level	$ dDV_{CC}/dt < 3 \text{ V/s}$	0.80	1.20	1.50	V
$V_{(DVCC_BOR_hys)}$	BOR _H hysteresis		50		250	mV
t_{RESET}	Pulse duration required at $\overline{\text{RST}}/\text{NMI}$ pin to accept a reset		2			μs

5.21 PMM, Core Voltage

over recommended ranges of supply voltage and operating free-air temperature (unless otherwise noted)

PARAMETER		TEST CONDITIONS	MIN	TYP	MAX	UNIT
$V_{\text{CORE3(AM)}}$	Core voltage, active mode, PMMCOREV = 3	$2.4 \text{ V} \leq DV_{CC} \leq 3.6 \text{ V}$		1.91		V
$V_{\text{CORE2(AM)}}$	Core voltage, active mode, PMMCOREV = 2	$2.2 \text{ V} \leq DV_{CC} \leq 3.6 \text{ V}$		1.81		V
$V_{\text{CORE1(AM)}}$	Core voltage, active mode, PMMCOREV = 1	$2 \text{ V} \leq DV_{CC} \leq 3.6 \text{ V}$		1.61		V
$V_{\text{CORE0(AM)}}$	Core voltage, active mode, PMMCOREV = 0	$1.8 \text{ V} \leq DV_{CC} \leq 3.6 \text{ V}$		1.41		V
$V_{\text{CORE3(LPM)}}$	Core voltage, low-current mode, PMMCOREV = 3	$2.4 \text{ V} \leq DV_{CC} \leq 3.6 \text{ V}$		1.94		V
$V_{\text{CORE2(LPM)}}$	Core voltage, low-current mode, PMMCOREV = 2	$2.2 \text{ V} \leq DV_{CC} \leq 3.6 \text{ V}$		1.92		V
$V_{\text{CORE1(LPM)}}$	Core voltage, low-current mode, PMMCOREV = 1	$2 \text{ V} \leq DV_{CC} \leq 3.6 \text{ V}$		1.73		V
$V_{\text{CORE0(LPM)}}$	Core voltage, low-current mode, PMMCOREV = 0	$1.8 \text{ V} \leq DV_{CC} \leq 3.6 \text{ V}$		1.52		V

5.22 PMM, SVS High Side

over recommended ranges of supply voltage and operating free-air temperature (unless otherwise noted)

PARAMETER		TEST CONDITIONS	MIN	TYP	MAX	UNIT
$I_{(SVSH)}$	SVS current consumption	SVSHE = 0, DV _{CC} = 3.6 V	0			nA
		SVSHE = 1, DV _{CC} = 3.6 V, SVSHFP = 0	200			
		SVSHE = 1, DV _{CC} = 3.6 V, SVSHFP = 1	1.5			μA
$V_{(SVSH_IT-)}$	SVS _H on voltage level	SVSHE = 1, SVSHRVL = 0	1.60	1.65	1.75	V
		SVSHE = 1, SVSHRVL = 1	1.77	1.84	1.95	
		SVSHE = 1, SVSHRVL = 2	1.93	2.00	2.12	
		SVSHE = 1, SVSHRVL = 3	2.09	2.16	2.29	
$V_{(SVSH_IT+)}$	SVS _H off voltage level	SVSHE = 1, SVSMHRRRL = 0	1.65	1.75	1.85	V
		SVSHE = 1, SVSMHRRRL = 1	1.85	1.95	2.05	
		SVSHE = 1, SVSMHRRRL = 2	2.05	2.15	2.25	
		SVSHE = 1, SVSMHRRRL = 3	2.15	2.25	2.35	
		SVSHE = 1, SVSMHRRRL = 4	2.30	2.40	2.55	
		SVSHE = 1, SVSMHRRRL = 5	2.57	2.70	2.83	
		SVSHE = 1, SVSMHRRRL = 6	2.90	3.05	3.20	
		SVSHE = 1, SVSMHRRRL = 7	2.90	3.05	3.20	
$t_{pd(SVSH)}$	SVS _H propagation delay	SVSHE = 1, dV _{DVCC} /dt = 10 mV/μs, SVSHFP = 1	2.5			μs
		SVSHE = 1, dV _{DVCC} /dt = 1 mV/μs, SVSHFP = 0	20			
$t_{(SVSH)}$	SVS _H on or off delay time	SVSHE = 0 → 1, dV _{DVCC} /dt = 10 mV/μs, SVSHFP = 1	12.5			μs
		SVSHE = 0 → 1, dV _{DVCC} /dt = 1 mV/μs, SVSHFP = 0	100			
dV _{DVCC} /dt	DVCC rise time		0		1000	V/s

5.23 PMM, SVM High Side

over recommended ranges of supply voltage and operating free-air temperature (unless otherwise noted)

PARAMETER		TEST CONDITIONS	MIN	TYP	MAX	UNIT
$I_{(SVMH)}$	SVM _H current consumption	SVMHE = 0, DV _{CC} = 3.6 V	0			nA
		SVMHE = 1, DV _{CC} = 3.6 V, SVMHFP = 0	200			
		SVMHE = 1, DV _{CC} = 3.6 V, SVMHFP = 1	1.5			μA
$V_{(SVMH)}$	SVM _H on or off voltage level ⁽¹⁾	SVMHE = 1, SVSMHRRRL = 0	1.63	1.73	1.83	V
		SVMHE = 1, SVSMHRRRL = 1	1.83	1.93	2.03	
		SVMHE = 1, SVSMHRRRL = 2	2.03	2.13	2.23	
		SVMHE = 1, SVSMHRRRL = 3	2.13	2.23	2.33	
		SVMHE = 1, SVSMHRRRL = 4	2.28	2.40	2.53	
		SVMHE = 1, SVSMHRRRL = 5	2.55	2.70	2.81	
		SVMHE = 1, SVSMHRRRL = 6	2.88	3.02	3.18	
		SVMHE = 1, SVSMHRRRL = 7	2.88	3.02	3.18	
		SVMHE = 1, SVMHOVPE = 1	3.77			
$t_{pd(SVMH)}$	SVM _H propagation delay	SVMHE = 1, dV _{DVCC} /dt = 10 mV/μs, SVMHFP = 1	2.5			μs
		SVMHE = 1, dV _{DVCC} /dt = 1 mV/μs, SVMHFP = 0	20			
$t_{(SVMH)}$	SVM _H on or off delay time	SVMHE = 0 → 1, dV _{DVCC} /dt = 10 mV/μs, SVMHFP = 1	12.5			μs
		SVMHE = 0 → 1, dV _{DVCC} /dt = 1 mV/μs, SVMHFP = 0	100			

(1) The SVM_H settings available depend on the VCORE (PMMCOREVx) setting. See the *Power Management Module and Supply Voltage Supervisor* chapter in the [MSP430x5xx and MSP430x6xx Family User's Guide](#) on recommended settings and use.

5.24 PMM, SVS Low Side

over recommended ranges of supply voltage and operating free-air temperature (unless otherwise noted)

PARAMETER		TEST CONDITIONS	MIN	TYP	MAX	UNIT
$I_{(SVSL)}$	SVS _L current consumption	SVSLE = 0, PMMCOREV = 2		0		nA
		SVSLE = 1, PMMCOREV = 2, SVSLFP = 0		200		
		SVSLE = 1, PMMCOREV = 2, SVSLFP = 1		1.5		μA
$t_{pd(SVSL)}$	SVS _L propagation delay	SVSLE = 1, $dV_{CORE}/dt = 10 \text{ mV}/\mu\text{s}$, SVSLFP = 1		2.5		μs
		SVSLE = 1, $dV_{CORE}/dt = 1 \text{ mV}/\mu\text{s}$, SVSLFP = 0		20		
$t_{(SVSL)}$	SVS _L on or off delay time	SVSLE = 0 → 1, $dV_{CORE}/dt = 10 \text{ mV}/\mu\text{s}$, SVSLFP = 1		12.5		μs
		SVSLE = 0 → 1, $dV_{CORE}/dt = 1 \text{ mV}/\mu\text{s}$, SVSLFP = 0		100		

5.25 PMM, SVM Low Side

over recommended ranges of supply voltage and operating free-air temperature (unless otherwise noted)

PARAMETER		TEST CONDITIONS	MIN	TYP	MAX	UNIT
$I_{(SVM)}$	SVM _L current consumption	SVMLE = 0, PMMCOREV = 2		0		nA
		SVMLE = 1, PMMCOREV = 2, SVMLEFP = 0		200		
		SVMLE = 1, PMMCOREV = 2, SVMLEFP = 1		1.5		μA
$t_{pd(SVM)}$	SVM _L propagation delay	SVMLE = 1, $dV_{CORE}/dt = 10 \text{ mV}/\mu\text{s}$, SVMLEFP = 1		2.5		μs
		SVMLE = 1, $dV_{CORE}/dt = 1 \text{ mV}/\mu\text{s}$, SVMLEFP = 0		20		
$t_{(SVM)}$	SVM _L on or off delay time	SVMLE = 0 → 1, $dV_{CORE}/dt = 10 \text{ mV}/\mu\text{s}$, SVMLEFP = 1		12.5		μs
		SVMLE = 0 → 1, $dV_{CORE}/dt = 1 \text{ mV}/\mu\text{s}$, SVMLEFP = 0		100		

5.26 Wake-up Times From Low-Power Modes and Reset

over recommended ranges of supply voltage and operating free-air temperature (unless otherwise noted)

PARAMETER		TEST CONDITIONS	MIN	TYP	MAX	UNIT
$t_{\text{WAKE-UP-FAST}}$	Wake-up time from LPM2, LPM3, or LPM4 to active mode ⁽¹⁾	PMMCOREV = SVSMLRRL = n (where n = 0, 1, 2, or 3), SVSLFP = 1, $f_{\text{MCLK}} \geq 4.0 \text{ MHz}$			5	μs
		$f_{\text{MCLK}} < 4.0 \text{ MHz}$			10	
$t_{\text{WAKE-UP-SLOW}}$	Wake-up time from LPM2, LPM3, or LPM4 to active mode ⁽²⁾⁽³⁾	PMMCOREV = SVSMLRRL = n (where n = 0, 1, 2, or 3), SVSLFP = 0		150	165	μs
$t_{\text{WAKE-UP-LPM4.5}}$	Wake-up time from LPM4.5 to active mode ⁽⁴⁾			2	3	ms
$t_{\text{WAKE-UP-RESET}}$	Wake-up time from $\overline{\text{RST}}$ or BOR event to active mode ⁽⁴⁾			2	3	ms

- (1) This value represents the time from the wake-up event to the first active edge of MCLK. The wake-up time depends on the performance mode of the low-side supervisor (SVS_L) and low-side monitor (SVM_L). $t_{\text{WAKE-UP-FAST}}$ is possible with SVS_L and SVM_L in full performance mode or disabled. For specific register settings, see the *Low-Side SVS and SVM Control and Performance Mode Selection* section in the *Power Management Module and Supply Voltage Supervisor* chapter of the *MSP430x5xx and MSP430x6xx Family User's Guide*.
- (2) This value represents the time from the wake-up event to the first active edge of MCLK. The wake-up time depends on the performance mode of the low-side supervisor (SVS_L) and low-side monitor (SVM_L). $t_{\text{WAKE-UP-SLOW}}$ is set with SVS_L and SVM_L in normal mode (low current mode). For specific register settings, see the *Low-Side SVS and SVM Control and Performance Mode Selection* section in the *Power Management Module and Supply Voltage Supervisor* chapter of the *MSP430x5xx and MSP430x6xx Family User's Guide*.
- (3) The wake-up times from LPM0 and LPM1 to AM are not specified. They are proportional to MCLK cycle time but are not affected by the performance mode settings as for LPM2, LPM3, and LPM4.
- (4) This value represents the time from the wake-up event to the reset vector execution.

5.27 Auxiliary Supplies Recommended Operating Conditions

over operating free-air temperature range (unless otherwise noted)

		MIN	NOM	MAX	UNIT
V _{CC}	Supply voltage range for all supplies at pins DVCC, AVCC, AUXVCC1, AUXVCC2, AUXVCC3	1.8		3.6	V
V _{DSYS}	Digital system supply voltage range, V _{DSYS} = V _{CC} – R _{ON} × I _{LOAD}	PMMCOREV _x = 0		3.6	V
		PMMCOREV _x = 1	2.0	3.6	
		PMMCOREV _x = 2	2.2	3.6	
		PMMCOREV _x = 3	2.4	3.6	
V _{ASYS}	Analog system supply voltage range, V _{ASYS} = V _{CC} – R _{ON} × I _{LOAD}	See module specifications			V
T _A	Ambient temperature range	–40		85	°C
T _{A,HTOL}	Ambient temperature during HTOL (module should be functional during HTOL)			150	°C
C _{VCC} , C _{AUX1/2}	Recommended capacitor at pins DVCC, AVCC, AUXVCC1, AUXVCC2		4.7		μF
C _{VSYS}	Recommended capacitor at pins VDSYS1, VDSYS2 and VASYS1, VASYS2		4.7		μF
C _{VCORE}	Recommended capacitance at pin V _{CORE}		0.47		μF
C _{AUX3}	Recommended capacitor at pin AUXVCC3		0.47		μF

5.28 Auxiliary Supplies, AUXVCC3 (Backup Subsystem) Currents

over operating free-air temperature range (unless otherwise noted)

PARAMETER	TEST CONDITIONS	V _{CC}	T _A	MIN	MAX	UNIT
I _{AUX3,RTCOn}	AUXVCC3 current with RTC enabled	3 V	25°C		0.86	μA
			85°C		1.2	
I _{AUX3,RTCoFF}	AUXVCC3 current with RTC disabled	3 V	25°C		120	nA
			85°C		220	

5.29 Auxiliary Supplies, Auxiliary Supply Monitor

over operating free-air temperature range (unless otherwise noted)

PARAMETER	TEST CONDITIONS	MIN	TYP	MAX	UNIT
I _{CC,Monitor}	Average supply current for monitoring circuitry drawn from V _{DSYS} LOCKAUX = 0, AUXMR _x = 0 AUX0MD = 0, AUX1MD = 0, AUX2MD = 1, V _{DSYS} = DVCC, V _{ASYS} = AVCC, Current measured at V _{DSYS}			1.10	μA
I _{Meas,Monitor}	Average current drawn from monitored supply during measurement cycle LOCKAUX = 0, AUXMR _x = 0 AUX0MD = 0, AUX1MD = 0, AUX2MD = 1, V _{DSYS} = DVCC, V _{ASYS} = AVCC, Current measured at AUXVCC1			0.13	μA
V _{Monitor}	General	V _{SVMH} (SVSMHRRL _x = AUXLVL _x)	V _{SVMH} (SVSMHRRL _x = AUXLVL _x)	V _{SVMH} (SVSMHRRL _x = AUXLVL _x)	V
		X – 5%		X + 5%	
	AUXLVL _x = 0	1.65	1.75	1.85	
	AUXLVL _x = 1	1.85	1.95	2.05	
	AUXLVL _x = 2	2.05	2.15	2.25	
	AUXLVL _x = 3	2.15	2.25	2.35	
	AUXLVL _x = 4	2.30	2.40	2.55	
	AUXLVL _x = 5	2.57	2.70	2.83	
AUXLVL _x = 6	2.90	3.00	3.20		
AUXLVL _x = 7	2.90	3.00	3.20		

5.30 Auxiliary Supplies, Switch ON-Resistance

over operating free-air temperature range (unless otherwise noted)

PARAMETER		TEST CONDITIONS	MIN	MAX	UNIT
$R_{ON,DVCC}$	ON-resistance of switch between DVCC and VDSYS	$I_{LOAD} = I_{CORE} + I_{IO} = 10 \text{ mA} + 10 \text{ mA} = 20 \text{ mA}$		5	Ω
$R_{ON,DAUX1}$	ON-resistance of switch between AUXVCC1 and VDSYS	$I_{LOAD} = I_{CORE} + I_{IO} = 10 \text{ mA} + 10 \text{ mA} = 20 \text{ mA}$		5	Ω
$R_{ON,DAUX2}$	ON-resistance of switch between AUXVCC2 and VDSYS	$I_{LOAD} = I_{CORE} + I_{IO} = 10 \text{ mA} + 10 \text{ mA} = 20 \text{ mA}$		5	Ω
$R_{ON,AVCC}$	ON-resistance of switch between AVCC and V _{ASYS}	$I_{LOAD} = I_{Modules} = 10 \text{ mA}$		5	Ω
$R_{ON,AAUX1}$	ON-resistance of switch between AUXVCC1 and V _{ASYS}	$I_{LOAD} = I_{Modules} = 5 \text{ mA}$		20	Ω
$R_{ON,AAUX2}$	ON-resistance of switch between AUXVCC2 and V _{ASYS}	$I_{LOAD} = I_{Modules} = 5 \text{ mA}$		20	Ω

5.31 Auxiliary Supplies, Switching Time

over operating free-air temperature range (unless otherwise noted)

PARAMETER		MIN	MAX	UNIT
t_{Switch}	Time from occurrence of trigger (SVM or software) to "new" supply connected to system supplies		100	ns
$t_{Recover}$	"Recovery time" after a switch over took place. During that time no further switching takes place.	170	480	μs

5.32 Auxiliary Supplies, Switch Leakage

over operating free-air temperature range (unless otherwise noted)

PARAMETER		TEST CONDITIONS	MIN	TYP	MAX	UNIT
$I_{SW,Lkg}$	Current into DVCC, AVCC, AUXVCC1, or AUXVCC2 if not selected	Per supply (but not the highest supply)		75	250	nA
I_{Vmax}	Current drawn from highest supply			500	700	nA

5.33 Auxiliary Supplies, Auxiliary Supplies to ADC10_A

over operating free-air temperature range (unless otherwise noted)

PARAMETER		TEST CONDITIONS	V _{CC}	MIN	TYP	MAX	UNIT
V_3	Supply voltage divider, $V_3 = V_{Supply}/3$		1.8 V	0.57	0.6	0.63	V
			3 V	0.95	1.0	1.05	
			3.6 V	1.14	1.2	1.26	
R_{V3}	Load resistance	AUXADCRx = 0				15	k Ω
		AUXADCRx = 1				1.5	
		AUXADCRx = 2				0.6	
$t_{Sample,V3}$	Sampling time required if V_3 selected	Error of conversion result ≤ 1 LSB	AUXADCRx = 0		1000		ns
			AUXADCRx = 1		1000		
			AUXADCRx = 2		1000		

5.34 Auxiliary Supplies, Charge Limiting Resistor

over operating free-air temperature range (unless otherwise noted)

PARAMETER		TEST CONDITIONS	V _{CC}	MIN	TYP	MAX	UNIT
R_{CHARGE}	Charge limiting resistor	AUXCHCx = 1	3 V			5	k Ω
		AUXCHCx = 2	3 V			10	
		AUXCHCx = 3	3 V			20	

5.35 Timer_A

over recommended ranges of supply voltage and operating free-air temperature (unless otherwise noted)

PARAMETER		TEST CONDITIONS	V _{CC}	MIN	MAX	UNIT
f _{TA}	Timer_A input clock frequency	Internal: SMCLK or ACLK, External: TACLK, Duty cycle = 50% ±10%	1.8 V, 3 V		25	MHz
t _{TA,cap}	Timer_A capture timing	All capture inputs, minimum pulse duration required for capture	1.8 V, 3 V	20		ns

5.36 eUSCI (UART Mode) Clock Frequency

over recommended ranges of supply voltage and operating free-air temperature (unless otherwise noted)

PARAMETER		TEST CONDITIONS	MIN	MAX	UNIT
f _{eUSCI}	eUSCI input clock frequency	Internal: SMCLK or ACLK, External: UCLK, Duty cycle = 50% ±10%		f _{SYSTEM}	MHz
f _{BITCLK}	BITCLK clock frequency (equals baud rate in MBaud)			5	MHz

5.37 eUSCI (UART Mode)

over recommended ranges of supply voltage and operating free-air temperature (unless otherwise noted)

PARAMETER		TEST CONDITIONS	V _{CC}	MIN	TYP	MAX	UNIT
t _t	UART receive deglitch time ⁽¹⁾	UCGLITx = 0	2 V, 3 V	10	15	25	ns
		UCGLITx = 1		30	50	85	
		UCGLITx = 2		50	80	150	
		UCGLITx = 3		70	120	200	

(1) Pulses on the UART receive input (UCxRX) shorter than the UART receive deglitch time are suppressed. To make sure that pulses are correctly recognized, their duration should exceed the maximum specification of the deglitch time.

5.38 eUSCI (SPI Master Mode) Clock Frequency

over recommended ranges of supply voltage and operating free-air temperature (unless otherwise noted)

PARAMETER		TEST CONDITIONS	MIN	MAX	UNIT
f_{eUSCI}	eUSCI input clock frequency	Internal: SMCLK or ACLK, Duty cycle = 50% ±10%		f_{SYSTEM}	MHz

5.39 eUSCI (SPI Master Mode)

over recommended ranges of supply voltage and operating free-air temperature (unless otherwise noted)⁽¹⁾

PARAMETER		TEST CONDITIONS	V _{CC}	MIN	MAX	UNIT
$t_{STE,LEAD}$	STE lead time, STE low to clock	UCSTEM = 0, UCMODEx = 01 or 10	2 V, 3 V	150		ns
		UCSTEM = 1, UCMODEx = 01 or 10	2 V, 3 V	150		
$t_{STE,LAG}$	STE lag time, Last clock to STE high	UCSTEM = 0, UCMODEx = 01 or 10	2 V, 3 V	200		ns
		UCSTEM = 1, UCMODEx = 01 or 10	2 V, 3 V	200		
$t_{STE,ACC}$	STE access time, STE low to SIMO data out	UCSTEM = 0, UCMODEx = 01 or 10	2 V		50	ns
			3 V		30	
		UCSTEM = 1, UCMODEx = 01 or 10	2 V		50	
			3 V		30	
$t_{STE,DIS}$	STE disable time, STE high to SIMO high impedance	UCSTEM = 0, UCMODEx = 01 or 10	2 V		40	ns
			3 V		25	
		UCSTEM = 1, UCMODEx = 01 or 10	2 V		40	
			3 V		25	
$t_{SU,MI}$	SOMI input data setup time		2 V		50	ns
			3 V		30	
$t_{HD,MI}$	SOMI input data hold time		2 V		0	ns
			3 V		0	
$t_{VALID,MO}$	SIMO output data valid time ⁽²⁾	UCLK edge to SIMO valid, C _L = 20 pF	2 V		9	ns
			3 V		5	
$t_{HD,MO}$	SIMO output data hold time ⁽³⁾	C _L = 20 pF	2 V		0	ns
			3 V		0	

- $f_{UCxCLK} = 1/2t_{LO/HI}$ with $t_{LO/HI} = \max(t_{VALID,MO}(eUSCI) + t_{SU,SI}(Slave), t_{SU,MI}(eUSCI) + t_{VALID,SO}(Slave))$
For the slave parameters $t_{SU,SI}(Slave)$ and $t_{VALID,SO}(Slave)$, see the SPI parameters of the attached slave.
- Specifies the time to drive the next valid data to the SIMO output after the output changing UCLK clock edge. See the timing diagrams in Figure 5-11 and Figure 5-12.
- Specifies how long data on the SIMO output is valid after the output changing UCLK clock edge. Negative values indicate that the data on the SIMO output can become invalid before the output changing clock edge observed on UCLK. See the timing diagrams in Figure 5-11 and Figure 5-12.

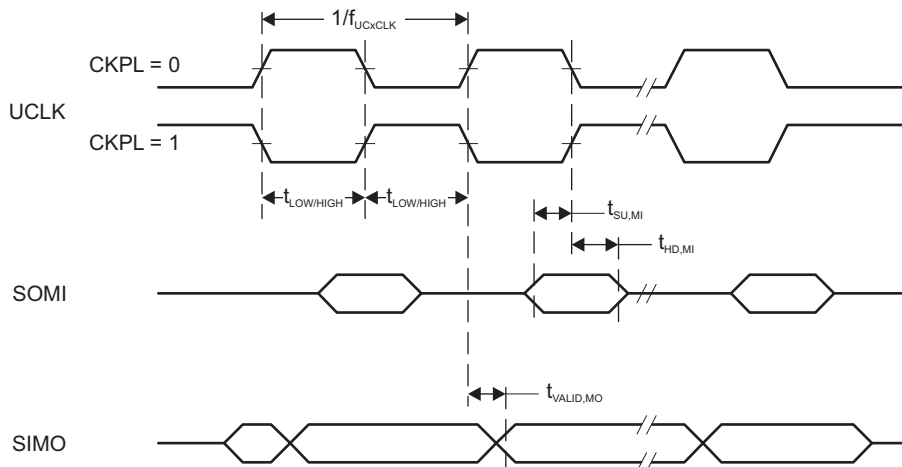

Figure 5-11. SPI Master Mode, CKPH = 0

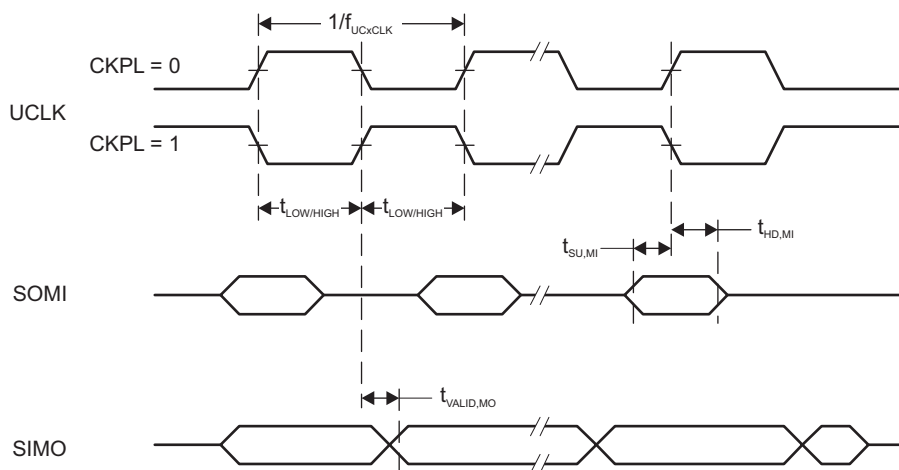

Figure 5-12. SPI Master Mode, CKPH = 1

5.40 eUSCI (SPI Slave Mode)

over recommended ranges of supply voltage and operating free-air temperature (unless otherwise noted)⁽¹⁾

PARAMETER	TEST CONDITIONS	V _{CC}	MIN	MAX	UNIT
t _{STE,LEAD} STE lead time, STE low to clock		2 V	4		ns
		3 V	3		
t _{STE,LAG} STE lag time, Last clock to STE high		2 V	0		ns
		3 V	0		
t _{STE,ACC} STE access time, STE low to SOMI data out		2 V		46	ns
		3 V		24	
t _{STE,DIS} STE disable time, STE high to SOMI high impedance		2 V		38	ns
		3 V		25	
t _{SU,SI} SIMO input data setup time		2 V	2		ns
		3 V	1		
t _{HD,SI} SIMO input data hold time		2 V	2		ns
		3 V	2		
t _{VALID,SO} SOMI output data valid time ⁽²⁾	UCLK edge to SOMI valid, C _L = 20 pF	2 V		55	ns
		3 V		32	
t _{HD,SO} SOMI output data hold time ⁽³⁾	C _L = 20 pF	2 V	24		ns
		3 V	16		

(1) $f_{UCxCLK} = 1/2t_{LO/HI}$ with $t_{LO/HI} \geq \max(t_{VALID,MO(Master)} + t_{SU,SI(eUSCI)}, t_{SU,MI(Master)} + t_{VALID,SO(eUSCI)})$

For the master parameters $t_{SU,MI(Master)}$ and $t_{VALID,MO(Master)}$, see the SPI parameters of the attached master.

(2) Specifies the time to drive the next valid data to the SOMI output after the output changing UCLK clock edge. See the timing diagrams in Figure 5-13 and Figure 5-14.

(3) Specifies how long data on the SOMI output is valid after the output changing UCLK clock edge. See the timing diagrams in Figure 5-13 and Figure 5-14.

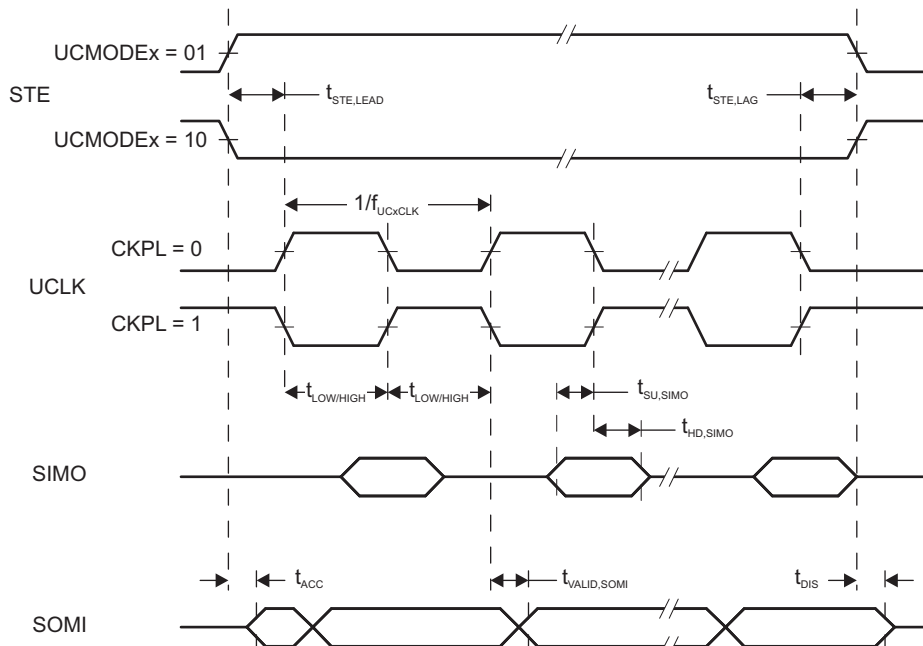

Figure 5-13. SPI Slave Mode, CKPH = 0

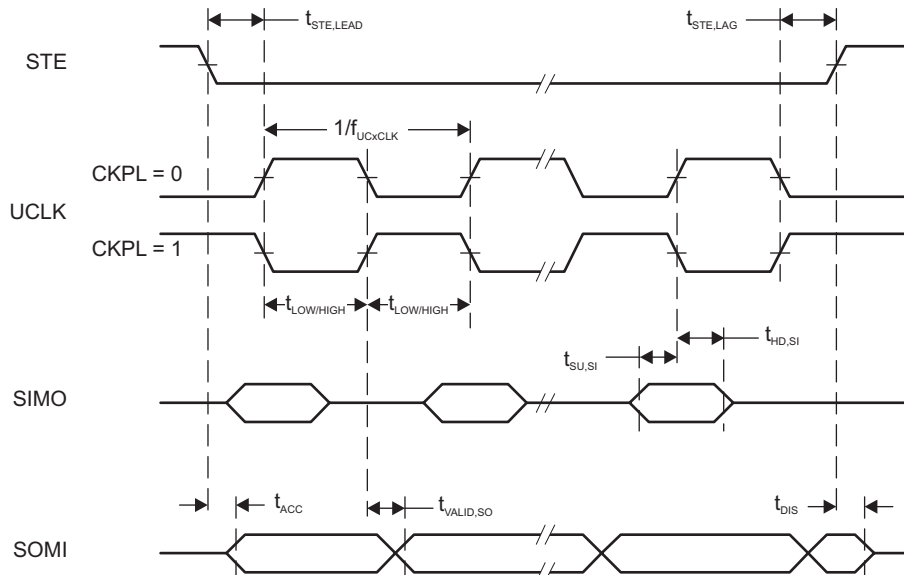

Figure 5-14. SPI Slave Mode, CKPH = 1

5.41 eUSCI (I²C Mode)

over recommended ranges of supply voltage and operating free-air temperature (unless otherwise noted) (see [Figure 5-15](#))

PARAMETER	TEST CONDITIONS	V _{CC}	MIN	TYP	MAX	UNIT	
f _{eUSCI}	eUSCI input clock frequency				f _{SYSTEM}	MHZ	
f _{SCL}	SCL clock frequency	2 V, 3 V	0		400	kHz	
t _{HD,STA}	Hold time (repeated) START	f _{SCL} = 100 kHz f _{SCL} > 100 kHz	2 V, 3 V	5.1 1.5		μs	
t _{SU,STA}	Setup time for a repeated START	f _{SCL} = 100 kHz f _{SCL} > 100 kHz	2 V, 3 V	5.1 1.4		μs	
t _{HD,DAT}	Data hold time		2 V, 3 V	0.4		μs	
t _{SU,DAT}	Data setup time	f _{SCL} = 100 kHz f _{SCL} > 100 kHz	2 V, 3 V	5.0 1.3		μs	
t _{SU,STO}	Setup time for STOP	f _{SCL} = 100 kHz f _{SCL} > 100 kHz	2 V, 3 V	5.2 1.7		μs	
t _{SP}	Pulse duration of spikes suppressed by input filter	UCGLITx = 0 UCGLITx = 1 UCGLITx = 2 UCGLITx = 3	2 V, 3 V		75	220	ns
					35	120	
					30	60	
					20	35	
t _{TIMEOUT}	Clock low time-out	UCCLTOx = 1 UCCLTOx = 2 UCCLTOx = 3	2 V, 3 V		30		ms
					33		
					37		

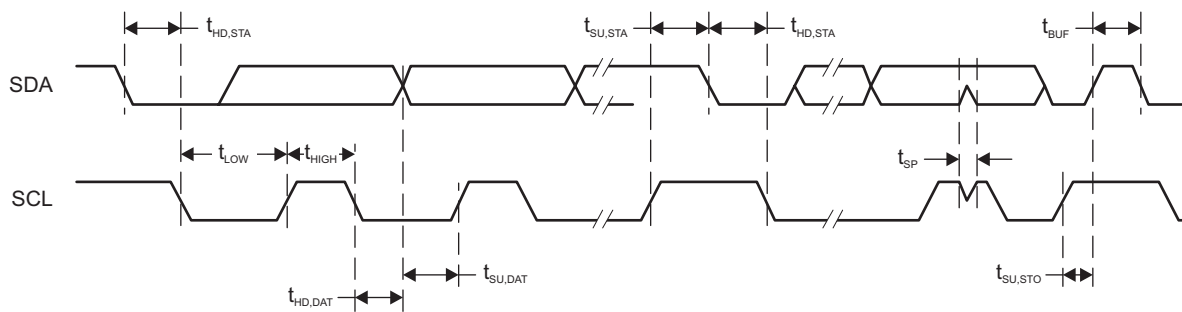

Figure 5-15. I²C Mode Timing

5.42 Schmitt-Trigger Inputs, RTC Tamper Detect Pin

over recommended ranges of supply voltage and operating free-air temperature (unless otherwise noted)

PARAMETER		TEST CONDITIONS	AUXVCC3	MIN	TYP	MAX	UNIT
V _{IT+}	Positive-going input threshold voltage		1.8 V	0.80		1.40	V
			3 V	1.50		2.10	
V _{IT-}	Negative-going input threshold voltage		1.8 V	0.45		1.00	V
			3 V	0.75		1.65	
V _{hys}	Input voltage hysteresis (V _{IT+} – V _{IT-})		1.8 V	0.3		0.85	V
			3 V	0.4		1.0	
R _{Pull}	Pullup or pulldown resistor	For pullup: V _{IN} = V _{SS} For pulldown: V _{IN} = AUXVCC3		20	35	50	kΩ
C _I	Input capacitance	V _{IN} = V _{SS} or AUXVCC3			5		pF

5.43 Inputs, RTC Tamper Detect Pin⁽¹⁾

over recommended ranges of supply voltage and operating free-air temperature (unless otherwise noted)

PARAMETER	TEST CONDITIONS	AUXVCC3	MIN	MAX	UNIT
t _(int)	External interrupt timing ⁽²⁾ Port P1, P2: P1.x to P2.x, external trigger pulse duration to set interrupt flag	2.2 V, 3 V	20		ns

- (1) Some devices may contain additional ports with interrupts. See the block diagram and terminal function descriptions.
 (2) An external signal sets the interrupt flag every time the minimum interrupt pulse duration t_(int) is met. It may be set by trigger signals shorter than t_(int).

5.44 Leakage Current, RTC Tamper Detect Pin

over recommended ranges of supply voltage and operating free-air temperature (unless otherwise noted)

PARAMETER	TEST CONDITIONS	AUXVCC3	MIN	MAX	UNIT
I _{lkg(Px.y)}	High-impedance leakage current	See ⁽¹⁾ ⁽²⁾	–50	+50	nA

- (1) The leakage current is measured with V_{SS} or V_{CC} applied to the corresponding pins, unless otherwise noted.
 (2) The leakage of the digital port pins is measured individually. The port pin is selected for input and the pullup or pulldown resistor is disabled.

5.45 Outputs, RTC Tamper Detect Pin

over recommended ranges of supply voltage and operating free-air temperature (unless otherwise noted)

PARAMETER	TEST CONDITIONS	AUXVCC3	MIN	MAX	UNIT
V _{OH}	I _(OHmax) = –100 μA ⁽¹⁾	1.8 V	1.50	1.80	V
			I _(OHmax) = –200 μA ⁽¹⁾	1.20	
	I _(OHmax) = –100 μA ⁽¹⁾	3 V	2.70	3.00	
			I _(OHmax) = –200 μA ⁽¹⁾	2.40	
V _{OL}	I _(OLmax) = 100 μA ⁽¹⁾	1.8 V	0.00	0.25	V
			I _(OLmax) = 200 μA ⁽¹⁾	0.00	
	I _(OLmax) = 100 μA ⁽¹⁾	3 V	0.00	0.25	
			I _(OLmax) = 200 μA ⁽¹⁾	0.00	

- (1) The maximum total current, I_(OHmax), for all outputs combined should not exceed ±20 mA to hold the maximum voltage drop specified. See Section 5.3 for more details.

5.46 LCD_C Recommended Operating Conditions

PARAMETER	CONDITIONS	MIN	NOM	MAX	UNIT
$V_{CC,LCD_C,CP\ en,3.6}$	Supply voltage range, charge pump enabled, $V_{LCD} \leq 3.6\text{ V}$			3.6	V
$V_{CC,LCD_C,CP\ en,3.3}$	Supply voltage range, charge pump enabled, $V_{LCD} \leq 3.3\text{ V}$			3.6	V
$V_{CC,LCD_C,int.\ bias}$	Supply voltage range, internal biasing, charge pump disabled			3.6	V
$V_{CC,LCD_C,ext.\ bias}$	Supply voltage range, external biasing, charge pump disabled			3.6	V
$V_{CC,LCD_C,VLCDEXT}$	Supply voltage range, external LCD voltage, internal or external biasing, charge pump disabled			3.6	V
$V_{LCDCAP/R33}$	External LCD voltage at LCDCAP/R33, internal or external biasing, charge pump disabled			3.6	V
C_{LDCAP}	Capacitor on LCDCAP when charge pump enabled		4.7	10	μF
f_{LCD}	LCD frequency range	0		1024	Hz
$f_{FRAME,4mux}$	LCD frame frequency range			128	Hz
$f_{FRAME,8mux}$	LCD frame frequency range			64	Hz
$f_{ACLK,in}$	ACLK input frequency range	30	32	40	kHz
C_{panel}	Panel capacitance			10000	pF
V_{R33}	Analog input voltage at R33			$V_{CC} + 0.2$	V
$V_{R23,1/3bias}$	Analog input voltage at R23		$V_{R13} \times \frac{V_{R03} + 2/3}{V_{R03}}$	V_{R33}	V
$V_{R13,1/3bias}$	Analog input voltage at R13 with 1/3 biasing		$V_{R03} \times \frac{V_{R03} + 1/3}{V_{R03}}$	V_{R23}	V
$V_{R13,1/2bias}$	Analog input voltage at R13 with 1/2 biasing		$V_{R03} \times \frac{V_{R03} + 1/2}{V_{R03}}$	V_{R33}	V
V_{R03}	Analog input voltage at R03		V_{SS}		V
$V_{LCD-V_{R03}}$	Voltage difference between V_{LCD} and R03			$V_{CC} + 0.2$	V
$V_{LCDREF/R13}$	External LCD reference voltage applied at LCDREF/R13		0.8	1.5	V

5.47 LCD_C Electrical Characteristics

over operating free-air temperature range (unless otherwise noted)

PARAMETER		TEST CONDITIONS	V _{CC}	MIN	TYP	MAX	UNIT	
V _{LCD}	LCD voltage	VLCDx = 0000, VLCDxEXT = 0	2.4 V to 3.6 V	V _{CC}			V	
		LCDCPEN = 1, VLCDx = 0001	2 V to 3.6 V	2.60				
		LCDCPEN = 1, VLCDx = 0010		2.66				
		LCDCPEN = 1, VLCDx = 0011		2.72				
		LCDCPEN = 1, VLCDx = 0100		2.78				
		LCDCPEN = 1, VLCDx = 0101		2.84				
		LCDCPEN = 1, VLCDx = 0110		2.90				
		LCDCPEN = 1, VLCDx = 0111		2.96				
		LCDCPEN = 1, VLCDx = 1000		3.02				
		LCDCPEN = 1, VLCDx = 1001		3.08				
		LCDCPEN = 1, VLCDx = 1010		3.14				
		LCDCPEN = 1, VLCDx = 1011		3.20				
		LCDCPEN = 1, VLCDx = 1100		3.26				
		LCDCPEN = 1, VLCDx = 1101		3.32				
		LCDCPEN = 1, VLCDx = 1110		2.2 V to 3.6 V	3.38			
		LCDCPEN = 1, VLCDx = 1111			3.50			3.72
I _{CC,Peak,CP}	Peak supply currents due to charge pump activities	LCDCPEN = 1, VLCDx = 1111	2.2 V	200			μA	
t _{LCD,CP,on}	Time to charge C _{LCD} when discharged	C _{LCD} = 4.7 μF, LCDCPEN = 0→1, VLCDx = 1111	2.2 V	100	500		ms	
I _{CP,Load}	Maximum charge pump load current	LCDCPEN = 1, VLCDx = 1111	2.2 V	50			μA	
R _{LCD,Seg}	LCD driver output impedance, segment lines	LCDCPEN = 1, VLCDx = 1000, I _{LOAD} = ±10 μA	2.2 V			10	kΩ	
R _{LCD,COM}	LCD driver output impedance, common lines	LCDCPEN = 1, VLCDx = 1000, I _{LOAD} = ±10 μA	2.2 V			10	kΩ	

5.48 SD24_B Power Supply and Recommended Operating Conditions

				MIN	TYP	MAX	UNIT
V_{CC}	Analog supply voltage	$V_{CC} = DV_{CC}$, $V_{SS} = DV_{SS} = 0\text{ V}$		2.4		3.6	V
T_A	Ambient temperature			-40		85	°C
f_{SD}	Modulator clock frequency			0.03		2.3	MHz
V_I	Absolute input voltage range			$V_{SS} - 1$		V_{CC}	V
V_{IC}	Common-mode input voltage range			$V_{SS} - 1$		V_{CC}	V
$V_{ID,FS}$	Differential full-scale input voltage	Bipolar mode, $V_{ID} = V_{I,A+} - V_{I,A-}$		$-V_{REF}/GAIN$		$+V_{REF}/GAIN$	mV
V_{ID}	Differential input voltage for specified performance ⁽¹⁾	REFON = 1	SD24GAINx = 1	±900	±930		mV
			SD24GAINx = 2	±450	±460		
			SD24GAINx = 4	±225	±230		
			SD24GAINx = 8	±112	±120		
			SD24GAINx = 16	±56	±60		
			SD24GAINx = 32	±28	±30		
			SD24GAINx = 64	±14	±14		
			SD24GAINx = 128	±7	±7.25		
C_{REF}	VREF load capacitance ⁽²⁾	SD24REFS = 1			100		nF

(1) The full-scale range (FSR) is defined by $V_{FS+} = +V_{REF}/GAIN$ and $V_{FS-} = -V_{REF}/GAIN$: $FSR = V_{FS+} - V_{FS-} = 2 \times V_{REF}/GAIN$. If V_{REF} is sourced externally, the analog input range should not exceed 80% of V_{FS+} or V_{FS-} , that is, $V_{ID} = 0.8 V_{FS-}$ to $0.8 V_{FS+}$. If V_{REF} is sourced internally, the given V_{ID} ranges apply. MIN values are calculated based on a V_{REF} of 1.125 V. TYP values are calculated based on a V_{REF} of 1.16 V.

(2) There is no capacitance required on VREF. However, TI recommends a capacitance of 100 nF to reduce any reference voltage noise.

5.49 SD24_B Analog Input ⁽¹⁾

also see [Figure 5-16](#)

PARAMETER		TEST CONDITIONS		V_{CC}	MIN	TYP	MAX	UNIT
C_I	Input capacitance	SD24GAINx = 1		3 V		5.0		pF
		SD24GAINx = 2				5.0		
		SD24GAINx = 4				5.0		
		SD24GAINx = 8				5.0		
		SD24GAINx = 16				5.0		
		SD24GAINx = 32, 64, 128				5.0		
Z_I	Input impedance (pin A+ or A- to V_{SS})	$f_{SD24} = 1\text{ MHz}$	SD24GAINx = 1	3 V		200		kΩ
			SD24GAINx = 8			200		
			SD24GAINx = 32			200		
Z_{ID}	Differential input impedance (pin A+ to pin A-)	$f_{SD24} = 1\text{ MHz}$	SD24GAINx = 1	3 V	300	400		kΩ
			SD24GAINx = 8			400		
			SD24GAINx = 32			300	400	

(1) All parameters pertain to each SD24_B converter.

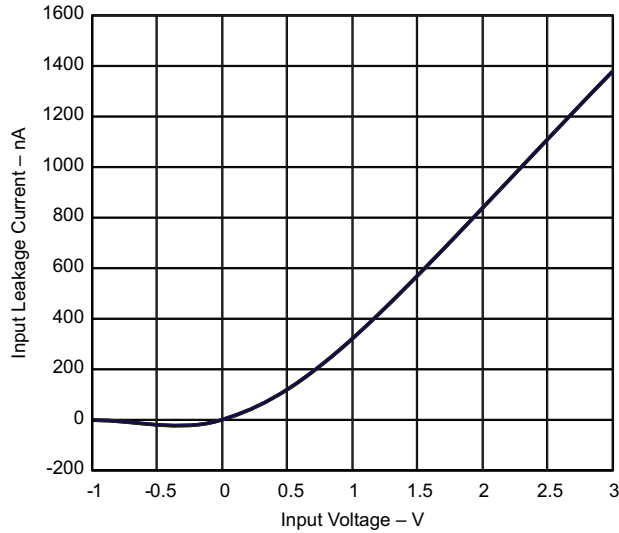

Figure 5-16. Input Leakage Current vs Input Voltage (Modulator OFF)

5.50 SD24_B Supply Currents

PARAMETER	TEST CONDITIONS	V _{CC}	MIN	TYP	MAX	UNIT
I _{SD,256} Analog plus digital supply current per converter (reference not included)	f _{SD24} = 1 MHz, SD24OSR = 256	3 V	SD24GAIN: 1	490	600	μA
			SD24GAIN: 2	490	600	
			SD24GAIN: 4	490	600	
			SD24GAIN: 8	559	700	
			SD24GAIN: 16	559	700	
			SD24GAIN: 32	627	800	
			SD24GAIN: 64	627	800	
			SD24GAIN: 128	627	800	
I _{SD,512} Analog plus digital supply current per converter (reference not included)	f _{SD24} = 2 MHz, SD24OSR = 512	3 V	SD24GAIN: 1	600	700	μA
			SD24GAIN: 8	677	800	
			SD24GAIN: 32	740	900	

5.51 SD24_B Performance

$f_{SD24} = 1$ MHz, $SD24OSRx = 256$, $SD24REFON = 1$

PARAMETER		TEST CONDITIONS	V _{CC}	MIN	TYP	MAX	UNIT
INL	Integral nonlinearity, end-point fit	SD24GAIN: 1	3 V	-0.01		+0.01	% FSR
		SD24GAIN: 8		-0.01		+0.01	
		SD24GAIN: 32		-0.01		+0.01	
G _{nom}	Nominal gain	SD24GAIN: 1	3 V		1		
		SD24GAIN: 2			2		
		SD24GAIN: 4			4		
		SD24GAIN: 8			8		
		SD24GAIN: 16			16		
		SD24GAIN: 32			32		
		SD24GAIN: 64			64		
		SD24GAIN: 128			128		
E _G	Gain error ⁽¹⁾	SD24GAIN: 1, with external reference (1.2 V)	3 V	-1%		+1%	
		SD24GAIN: 8, with external reference (1.2 V)		-2%		+2%	
		SD24GAIN: 32, with external reference (1.2 V)		-2%		+2%	
ΔE _G /ΔT	Gain error temperature coefficient ⁽²⁾ , internal reference	SD24GAIN: 1, 8, or 32 (with internal reference)	3 V			80	ppm/°C
ΔE _G /ΔT	Gain error temperature coefficient ⁽²⁾ , external reference	SD24GAIN: 1 (with external reference)	3 V			15	ppm/°C
		SD24GAIN: 8 (with external reference)				15	
		SD24GAIN: 32 (with external reference)				15	
ΔE _G /ΔV _{CC}	Gain error vs V _{CC} ⁽³⁾	SD24GAIN: 1	3 V		0.1		%V
		SD24GAIN: 8			0.1		
		SD24GAIN: 32			0.4		
E _{OS} [V]	Offset error ⁽⁴⁾	SD24GAIN: 1 (with V _{diff} = 0 V)	3 V			2.3	mV
		SD24GAIN: 8				1	
		SD24GAIN: 32				0.5	
E _{OS} [FS]	Offset error ⁽⁴⁾	SD24GAIN: 1 (with V _{diff} = 0 V)	3 V	-0.2		+0.2	% FS
		SD24GAIN: 8		-0.7		+0.7	
		SD24GAIN: 32		-1.4		+1.4	
ΔE _{OS} /ΔT	Offset error temperature coefficient ⁽⁵⁾	SD24GAIN: 1	3 V		2		μV/°C
		SD24GAIN: 8			0.25		
		SD24GAIN: 32			0.1		

- The gain error E_G specifies the deviation of the actual gain G_{act} from the nominal gain G_{nom}: $E_G = (G_{act} - G_{nom})/G_{nom}$. It covers process, temperature, and supply voltage variations.
- The gain error temperature coefficient ΔE_G/ΔT specifies the variation of the gain error E_G over temperature ($E_G(T) = (G_{act}(T) - G_{nom})/G_{nom}$) using the box method (that is, minimum and maximum values):
 $\Delta E_G / \Delta T = (\text{MAX}(E_G(T)) - \text{MIN}(E_G(T))) / (\text{MAX}(T) - \text{MIN}(T)) = (\text{MAX}(G_{act}(T)) - \text{MIN}(G_{act}(T))) / G_{nom} / (\text{MAX}(T) - \text{MIN}(T))$
with T ranging from -40°C to 85°C.
- The gain error vs V_{CC} coefficient ΔE_G/ΔV_{CC} specifies the variation of the gain error E_G over supply voltage ($E_G(V_{CC}) = (G_{act}(V_{CC}) - G_{nom})/G_{nom}$) using the box method (that is, minimum and maximum values):
 $\Delta E_G / \Delta V_{CC} = (\text{MAX}(E_G(V_{CC})) - \text{MIN}(E_G(V_{CC}))) / (\text{MAX}(V_{CC}) - \text{MIN}(V_{CC})) = (\text{MAX}(G_{act}(V_{CC})) - \text{MIN}(G_{act}(V_{CC}))) / G_{nom} / (\text{MAX}(V_{CC}) - \text{MIN}(V_{CC}))$
with V_{CC} ranging from 2.4 V to 3.6 V.
- The offset error E_{OS} is measured with shorted inputs in 2s-complement mode with +100% FS = V_{REF}/G and -100% FS = -V_{REF}/G. Conversion between E_{OS} [FS] and E_{OS} [V] is as follows: E_{OS} [FS] = E_{OS} [V] × G/V_{REF}, E_{OS} [V] = E_{OS} [FS] × V_{REF}/G.
- The offset error temperature coefficient ΔE_{OS}/ΔT specifies the variation of the offset error E_{OS} over temperature using the box method (that is, minimum and maximum values):
 $\Delta E_{OS} / \Delta T = (\text{MAX}(E_{OS}(T)) - \text{MIN}(E_{OS}(T))) / (\text{MAX}(T) - \text{MIN}(T))$
with T ranging from -40°C to 85°C.

SD24_B Performance (continued)
 $f_{SD24} = 1 \text{ MHz}$, $SD24OSRx = 256$, $SD24REFON = 1$

PARAMETER		TEST CONDITIONS	V _{CC}	MIN	TYP	MAX	UNIT
$\Delta E_{OS}/\Delta V_{CC}$	Offset error vs V _{CC} ⁽⁶⁾	SD24GAIN: 1	3 V		500		$\mu\text{V/V}$
		SD24GAIN: 8			125		
		SD24GAIN: 32			50		
CMRR,DC	Common-mode rejection at DC ⁽⁷⁾	SD24GAIN: 1	3 V		-120		dB
		SD24GAIN: 8			-110		
		SD24GAIN: 32			-100		
CMRR,50 Hz	Common-mode rejection at 50 Hz ⁽⁸⁾	SD24GAIN: 1, f _{CM} = 50 Hz, V _{CM} = 930 mV	3 V		-120		dB
		SD24GAIN: 8, f _{CM} = 50 Hz, V _{CM} = 120 mV			-110		
		SD24GAIN: 32, f _{CM} = 50 Hz, V _{CM} = 30 mV			-100		
AC PSRR,ext	AC power supply rejection ratio, external reference ⁽⁹⁾	SD24GAIN: 1, V _{CC} = 3 V + 50 mV × sin(2π × f _{VCC} × t), f _{VCC} = 50 Hz			-61		dB
		SD24GAIN: 8, V _{CC} = 3 V + 50 mV × sin(2π × f _{VCC} × t), f _{VCC} = 50 Hz			-75		
		SD24GAIN: 32, V _{CC} = 3 V + 50 mV × sin(2π × f _{VCC} × t), f _{VCC} = 50 Hz			-79		
AC PSRR,int	AC power supply rejection ratio, internal reference ⁽⁹⁾	SD24GAIN: 1, V _{CC} = 3 V + 50 mV × sin(2π × f _{VCC} × t), f _{VCC} = 50 Hz			-61		dB
		SD24GAIN: 8, V _{CC} = 3 V + 50 mV × sin(2π × f _{VCC} × t), f _{VCC} = 50 Hz			-75		
		SD24GAIN: 32, V _{CC} = 3 V + 50 mV × sin(2π × f _{VCC} × t), f _{VCC} = 50 Hz			-79		
XT	Crosstalk between converters ⁽¹⁰⁾	Crosstalk source: SD24GAIN: 1, Sine-wave with maximum possible V _{pp} , f _{IN} = 50 Hz or 100 Hz, Converter under test: SD24GAIN: 1	3 V		-120		dB
		Crosstalk source: SD24GAIN: 1, Sine-wave with maximum possible V _{pp} , f _{IN} = 50 Hz or 100 Hz, Converter under test: SD24GAIN: 8			-115		
		Crosstalk source: SD24GAIN: 1, Sine-wave with maximum possible V _{pp} , f _{IN} = 50 Hz or 100 Hz, Converter under test: SD24GAIN: 32			-110		

- (6) The offset error vs V_{CC} $\Delta E_{OS} / \Delta V_{CC}$ specifies the variation of the offset error E_{OS} over supply voltage using the box method (that is, minimum and maximum values):

$$\Delta E_{OS} / \Delta V_{CC} = (\text{MAX}(E_{OS}(V_{CC})) - \text{MIN}(E_{OS}(V_{CC}))) / (\text{MAX}(V_{CC}) - \text{MIN}(V_{CC}))$$
 with V_{CC} ranging from 2.4 V to 3.6 V.
- (7) The DC CMRR specifies the change in the measured differential input voltage value when the common-mode voltage varies:
 DC CMRR = -20log($\Delta_{MAX} / \text{FSR}$) with Δ_{MAX} being the difference between the minimum value and the maximum value measured when sweeping the common-mode voltage.
 The DC CMRR is measured with both inputs connected to the common-mode voltage (that is, no differential input signal is applied), and the common-mode voltage is swept from -1 V to V_{CC}.
- (8) The AC CMRR is the difference between a hypothetical signal with the amplitude and frequency of the applied common-mode ripple applied to the inputs of the ADC and the actual common-mode signal spur visible in the FFT spectrum:
 AC CMRR = Error Spur [dBFS] - 20log(V_{CM} / 1.2 V / G) [dBFS] with a common-mode signal of V_{CM} × sin(2π × f_{CM} × t) applied to the analog inputs.
 The AC CMRR is measured with the both inputs connected to the common-mode signal; that is, no differential input signal is applied. With the specified typical values the error spur is within the noise floor (as specified by the SINAD values).
- (9) The AC PSRR is the difference between a hypothetical signal with the amplitude and frequency of the applied supply voltage ripple applied to the inputs of the ADC and the actual supply ripple spur visible in the FFT spectrum:
 AC PSRR = Error Spur [dBFS] - 20log(50 mV / 1.2 V / G) [dBFS] with a signal of 50 mV × sin(2π × f_{VCC} × t) added to V_{CC}.
 The AC PSRR is measured with the inputs grounded; that is, no analog input signal is applied.
 With the specified typical values the error spur is within the noise floor (as specified by the SINAD values).
 SD24GAIN: 1 → Hypothetical signal: 20log(50 mV / 1.2 V / 1) = -27.6 dBFS
 SD24GAIN: 8 → Hypothetical signal: 20log(50 mV / 1.2 V / 8) = -9.5 dBFS
 SD24GAIN: 32 → Hypothetical signal: 20log(50 mV / 1.2 V / 32) = 2.5 dBFS
- (10) The crosstalk (XT) is specified as the tone level of the signal applied to the crosstalk source seen in the spectrum of the converter under test. It is measured with the inputs of the converter under test being grounded.

5.52 SD24_B, AC Performance

$f_{SD24} = 1$ MHz, SD24OSRx = 256, SD24REFON = 1 (see [Figure 5-17](#))

PARAMETER		TEST CONDITIONS	V _{CC}	MIN	TYP	MAX	UNIT
SINAD	Signal-to-noise + distortion ratio	SD24GAIN: 1	3 V	84	86		dB
		SD24GAIN: 2					
		SD24GAIN: 4					
		SD24GAIN: 8					
		SD24GAIN: 16					
		SD24GAIN: 32					
		SD24GAIN: 64					
		SD24GAIN: 128					
THD	Total harmonic distortion	SD24GAIN: 1	3 V	95	90		dB
		SD24GAIN: 8					
		SD24GAIN: 32					

(1) The following voltages were applied to the SD24_B inputs: $V_{I,A+}(t) = 0\text{ V} + V_{PP} / 2 \times \sin(2\pi \times f_{IN} \times t)$ and $V_{I,A-}(t) = 0\text{ V} - V_{PP} / 2 \times \sin(2\pi \times f_{IN} \times t)$ resulting in a differential voltage of $V_{ID} = V_{I,A+}(t) - V_{I,A-}(t) = V_{PP} \times \sin(2\pi \times f_{IN} \times t)$ with V_{PP} being selected as the maximum value allowed for a given range (according to SD24_B recommended operating conditions).

5.53 SD24_B, AC Performance

$f_{SD24} = 2$ MHz, SD24OSRx = 512, SD24REFON = 1

PARAMETER		TEST CONDITIONS	V _{CC}	MIN	TYP	MAX	UNIT
SINAD	Signal-to-noise + distortion ratio	SD24GAIN: 1	3 V	87	85		dB
		SD24GAIN: 2					
		SD24GAIN: 4					
		SD24GAIN: 8					
		SD24GAIN: 16					
		SD24GAIN: 32					
		SD24GAIN: 64					
		SD24GAIN: 128					

(1) The following voltages were applied to the SD24_B inputs: $V_{I,A+}(t) = 0\text{ V} + V_{PP} / 2 \times \sin(2\pi \times f_{IN} \times t)$ and $V_{I,A-}(t) = 0\text{ V} - V_{PP} / 2 \times \sin(2\pi \times f_{IN} \times t)$ resulting in a differential voltage of $V_{ID} = V_{I,A+}(t) - V_{I,A-}(t) = V_{PP} \times \sin(2\pi \times f_{IN} \times t)$ with V_{PP} being selected as the maximum value allowed for a given range (according to SD24_B recommended operating conditions).

5.54 SD24_B, AC Performance

$f_{SD24} = 32$ kHz, SD24OSRx = 512, SD24REFON = 1

PARAMETER		TEST CONDITIONS	V _{CC}	MIN	TYP	MAX	UNIT
SINAD	Signal-to-noise + distortion ratio	SD24GAIN: 1	3 V	89	85		dB
		SD24GAIN: 2					
		SD24GAIN: 4					
		SD24GAIN: 8					
		SD24GAIN: 16					
		SD24GAIN: 32					
		SD24GAIN: 64					
		SD24GAIN: 128					

(1) The following voltages were applied to the SD24_B inputs: $V_{I,A+}(t) = 0\text{ V} + V_{PP} / 2 \times \sin(2\pi \times f_{IN} \times t)$ and $V_{I,A-}(t) = 0\text{ V} - V_{PP} / 2 \times \sin(2\pi \times f_{IN} \times t)$ resulting in a differential voltage of $V_{ID} = V_{I,A+}(t) - V_{I,A-}(t) = V_{PP} \times \sin(2\pi \times f_{IN} \times t)$ with V_{PP} being selected as the maximum value allowed for a given range (according to SD24_B recommended operating conditions) (also see [Figure 5-18](#)).

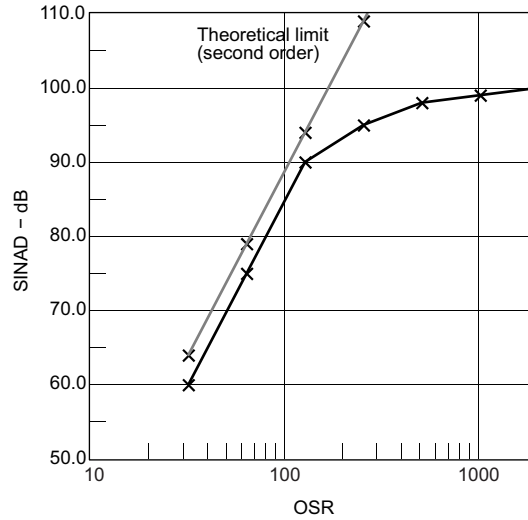

Figure 5-17. SINAD vs OSR
($f_{SD24} = 1$ MHz, SD24REFON = 1, SD24GAIN: 1)

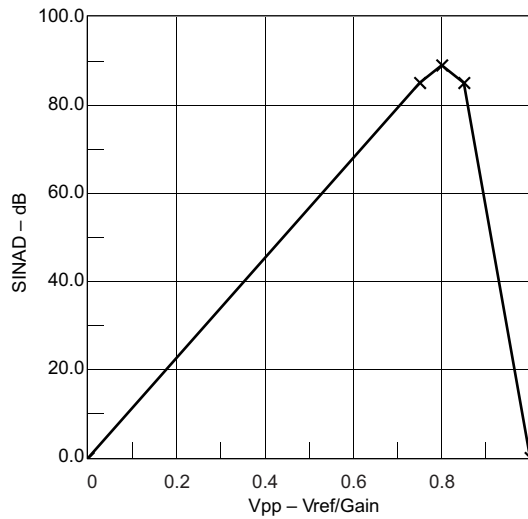

Figure 5-18. SINAD vs V_{PP}

5.55 SD24_B External Reference Input

ensure correct input voltage range according to V_{REF}

PARAMETER	TEST CONDITIONS	V _{CC}	MIN	TYP	MAX	UNIT
$V_{REF(I)}$ Input voltage	SD24REFS = 0	3 V	1.0	1.20	1.5	V
$I_{REF(I)}$ Input current	SD24REFS = 0	3 V			50	nA

5.56 10-Bit ADC Power Supply and Input Range Conditions

over recommended ranges of supply voltage and operating free-air temperature (unless otherwise noted)

PARAMETER		TEST CONDITIONS	V _{CC}	MIN	TYP	MAX	UNIT
AV _{CC}	Analog supply voltage	AVCC and DVCC are connected together, AVSS and DVSS are connected together, V _(AVSS) = V _(DVSS) = 0 V		1.8		3.6	V
V _(Ax)	Analog input voltage range ⁽¹⁾	All ADC10_A pins		0		AV _{CC}	V
I _{ADC10_A}	Operating supply current into AVCC terminal, REF module and reference buffer off	f _{ADC10CLK} = 5 MHz, ADC10ON = 1, REFON = 0, SHT0 = 0, SHT1 = 0, ADC10DIV = 0, ADC10SREF = 00	2.2 V		68	100	μA
			3 V		78	110	
	Operating supply current into AVCC terminal, REF module on, reference buffer on	f _{ADC10CLK} = 5 MHz, ADC10ON = 1, REFON = 1, SHT0 = 0, SHT1 = 0, ADC10DIV = 0, ADC10SREF = 01			124	180	
		f _{ADC10CLK} = 5 MHz, ADC10ON = 1, REFON = 0, SHT0 = 0, SHT1 = 0, ADC10DIV = 0, ADC10SREF = 10, V _{REF} = 2.5 V	3 V		105	160	
Operating supply current into AVCC terminal, REF module off, reference buffer off	f _{ADC10CLK} = 5 MHz, ADC10ON = 1, REFON = 0, SHT0 = 0, SHT1 = 0, ADC10DIV = 0, ADC10SREF = 11, V _{REF} = 2.5 V			72	110		
C _I	Input capacitance	Only one terminal Ax can be selected at one time from the pad to the ADC10_A capacitor array including wiring and pad.	2.2 V		3.5		pF
R _I	Input MUX ON resistance	AV _{CC} > 2.0 V, 0 V ≤ V _{Ax} ≤ AV _{CC}				36	kΩ
		1.8 V < AV _{CC} < 2.0 V, 0 V ≤ V _{Ax} ≤ AV _{CC}				96	

- (1) The analog input voltage range must be within the selected reference voltage range V_{R+} to V_{R-} for valid conversion results. The external reference voltage requires decoupling capacitors. Two decoupling capacitors, 10 μF and 100 nF, should be connected to VREF to decouple the dynamic current required for an external reference source if it is used for the ADC10_A. Also see the [MSP430x5xx and MSP430x6xx Family User's Guide](#).

5.57 10-Bit ADC Switching Characteristics

over recommended ranges of supply voltage and operating free-air temperature (unless otherwise noted)

PARAMETER		TEST CONDITIONS	V _{CC}	MIN	TYP	MAX	UNIT
f _{ADC10CLK}		For specified performance of ADC10_A linearity parameters	2.2 V, 3 V	0.45	5	5.5	MHz
f _{ADC10OSC}	Internal ADC10_A oscillator ⁽¹⁾	ADC10DIV = 0, f _{ADC10CLK} = f _{ADC10OSC}	2.2 V, 3 V	4.4	4.9	5.6	MHz
t _{CONVERT}	Conversion time	REFON = 0, Internal oscillator, 12 ADC10CLK cycles, 10-bit mode, f _{ADC10OSC} = 4 MHz to 5 MHz	2.2 V, 3 V	2.4		3.0	μs
		External f _{ADC10CLK} from ACLK, MCLK, or SMCLK, ADC10SSEL ≠ 0			12 × 1 / f _{ADC10CLK}		
t _{ADC10ON}	Turnon settling time of the ADC	See ⁽²⁾				100	ns
t _{Sample}	Sampling time	R _S = 1000 Ω, R _I = 96 kΩ, C _I = 3.5 pF ⁽³⁾	1.8 V	3			μs
		R _S = 1000 Ω, R _I = 36 kΩ, C _I = 3.5 pF ⁽³⁾	3 V	1			

- (1) The ADC10OSC is sourced directly from MODOSC inside the UCS.
(2) The condition is that the error in a conversion started after t_{ADC10ON} is less than ±0.5 LSB. The reference and input signal are already settled.
(3) Approximately 8 Tau (τ) are needed to get an error of less than ±0.5 LSB

5.58 10-Bit ADC Linearity Parameters

over recommended ranges of supply voltage and operating free-air temperature (unless otherwise noted)

PARAMETER	TEST CONDITIONS	V _{CC}	MIN	MAX	UNIT
E _I Integral linearity error	1.4 V ≤ (V _{eREF+} – V _{eREF-}) ≤ 1.6 V, C _{VeREF+} = 20 pF	2.2 V, 3 V	-1.0	+1.0	LSB
	1.6 V < (V _{eREF+} – V _{eREF-}) ≤ V _{AVCC} , C _{VeREF+} = 20 pF		-1.0	+1.0	
E _D Differential linearity error	1.4 V ≤ (V _{eREF+} – V _{eREF-}), C _{VeREF+} = 20 pF	2.2 V, 3 V	-1.0	+1.0	LSB
E _O Offset error	1.4 V ≤ (V _{eREF+} – V _{eREF-}), C _{VeREF+} = 20 pF Internal impedance of source R _S < 100 Ω	2.2 V, 3 V	-1.0	+1.0	LSB
E _G Gain error	1.4 V ≤ (V _{eREF+} – V _{eREF-}), C _{VeREF+} = 20 pF, ADC10SREFX = 11b	2.2 V, 3 V	-1.0	+1.0	LSB
E _T Total unadjusted error	1.4 V ≤ (V _{eREF+} – V _{eREF-}), C _{VeREF+} = 20 pF, ADC10SREFX = 11b	2.2 V, 3 V	-2.0	+2.0	LSB

5.59 10-Bit ADC External Reference

over recommended ranges of supply voltage and operating free-air temperature (unless otherwise noted)⁽¹⁾

PARAMETER	TEST CONDITIONS	V _{CC}	MIN	MAX	UNIT
V _{eREF+} Positive external reference voltage input	V _{eREF+} > V _{eREF-} ⁽²⁾		1.4	AV _{CC}	V
V _{eREF-} Negative external reference voltage input	V _{eREF+} > V _{eREF-} ⁽³⁾		0	1.2	V
(V _{eREF+} – V _{eREF-}) Differential external reference voltage input	V _{eREF+} > V _{eREF-} ⁽⁴⁾		1.4	AV _{CC}	V
I _{VeREF+} , I _{VeREF-} Static input current	1.4 V ≤ V _{eREF+} ≤ V _{AVCC} , V _{eREF-} = 0 V, f _{ADC10CLK} = 5 MHz, ADC10SHTX = 0x0001, Conversion rate 200 ksps	2.2 V, 3 V	-26	+26	μA
	1.4 V ≤ V _{eREF+} ≤ V _{AVCC} , V _{eREF-} = 0 V, f _{ADC10CLK} = 5 MHz, ADC10SHTX = 0x1000, Conversion rate 20 ksps		-1	+1	
C _{VREF+} Capacitance at VREF+ terminal	See ⁽⁵⁾		10		μF

- The external reference is used during ADC conversion to charge and discharge the capacitance array. The input capacitance, C_I, is also the dynamic load for an external reference during conversion. The dynamic impedance of the reference supply should follow the recommendations on analog-source impedance to allow the charge to settle for 10-bit accuracy.
- The accuracy limits the minimum positive external reference voltage. Lower reference voltage levels may be applied with reduced accuracy requirements.
- The accuracy limits the maximum negative external reference voltage. Higher reference voltage levels may be applied with reduced accuracy requirements.
- The accuracy limits minimum external differential reference voltage. Lower differential reference voltage levels may be applied with reduced accuracy requirements.
- Two decoupling capacitors, 10 μF and 100 nF, should be connected to VREF to decouple the dynamic current required for an external reference source if it is used for the ADC10_A. Also see the *MSP430x5xx and MSP430x6xx Family User's Guide*.

5.60 REF Built-In Reference

over recommended ranges of supply voltage and operating free-air temperature (unless otherwise noted)

PARAMETER		TEST CONDITIONS	V _{CC}	MIN	TYP	MAX	UNIT
V _{REF+}	Positive built-in reference voltage	REFVSEL = {2} for 2.5 V, REFON = 1	3 V	2.47	2.51	2.55	V
		REFVSEL = {1} for 2 V, REFON = 1		1.96	1.99	2.02	
		REFVSEL = {0} for 1.5 V, REFON = 1	2.2 V, 3 V	1.48	1.5	1.52	
AV _{CC(min)}	AV _{CC} minimum voltage, Positive built-in reference active	REFVSEL = {0} for 1.5 V		1.8			V
		REFVSEL = {1} for 2 V		2.2			
		REFVSEL = {2} for 2.5 V		2.7			
I _{REF+}	Operating supply current into AV _{CC} terminal ⁽¹⁾	f _{ADC10CLK} = 5.0 MHz, REFON = 1, REFBURST = 0, REFVSEL = {2} for 2.5 V	3 V		18	24	μA
		f _{ADC10CLK} = 5.0 MHz, REFON = 1, REFBURST = 0, REFVSEL = {1} for 2 V			16.1	21	
		f _{ADC10CLK} = 5.0 MHz, REFON = 1, REFBURST = 0, REFVSEL = {0} for 1.5 V			14.4	21	
TC _{REF+}	Temperature coefficient of built-in reference ⁽²⁾	I _{VREF+} = 0 A, REFVSEL = {0, 1, 2}, REFON = 1		<18	50		ppm/°C
I _{SENSOR}	Operating supply current into AV _{CC} terminal ⁽³⁾	REFON = 0, INCH = 0Ah, ADC10ON = N/A, T _A = 30°C	2.2 V	17	22	μA	
			3 V	17	22		
V _{SENSOR}	See ⁽⁴⁾	ADC10ON = 1, INCH = 0Ah, T _A = 30°C	2.2 V	770		mV	
			3 V	770			
V _{MID}	AV _{CC} divider at channel 11	ADC10ON = 1, INCH = 0Bh, V _{MID} ≈ 0.5 × V _{AVCC}	2.2 V	1.06	1.1	1.14	V
			3 V	1.46	1.5	1.54	
t _{SENSOR(sample)}	Sample time required if channel 10 is selected ⁽⁵⁾	ADC10ON = 1, INCH = 0Ah, Error of conversion result ≤ 1 LSB		30			μs
t _{V_{MID}(sample)}	Sample time required if channel 11 is selected ⁽⁶⁾	ADC10ON = 1, INCH = 0Bh, Error of conversion result ≤ 1 LSB		1			μs
PSRR _{DC}	Power supply rejection ratio (DC)	AV _{CC} = AV _{CC(min)} to AV _{CC(max)} , T _A = 25°C, REFVSEL = {0, 1, 2}, REFON = 1		120			μV/V
PSRR _{AC}	Power supply rejection ratio (AC)	AV _{CC} = AV _{CC(min)} to AV _{CC(max)} , T _A = 25°C, f = 1 kHz, ΔV _{pp} = 100 mV, REFVSEL = {0, 1, 2}, REFON = 1		6.4			mV/V
t _{SETTLE}	Settling time of reference voltage ⁽⁷⁾	AV _{CC} = AV _{CC(min)} to AV _{CC(max)} , REFVSEL = {0, 1, 2}, REFON = 0→1		75			μs
V _{SD24REF}	SD24_B internal reference voltage	SD24REFS = 1	3 V	1.151	1.1623	1.174	V
t _{ON}	SD24_B internal reference turnon time	SD24REFS = 0→1, C _{REF} = 100 nF	3 V	200			μs

- (1) The internal reference current is supplied from the AV_{CC} terminal. Consumption is independent of the ADC10ON control bit, unless a conversion is active. The REFON bit enables to settle the built-in reference before starting an analog-to-digital conversion.
- (2) Calculated using the box method: (MAX(−40°C to 85°C) − MIN(−40°C to 85°C)) / MIN(−40°C to 85°C) / (85°C − (−40°C)).
- (3) The sensor current I_{SENSOR} is consumed if (ADC10ON = 1 and REFON = 1) or (ADC10ON = 1 and INCH = 0Ah and sample signal is high). When REFON = 1, I_{SENSOR} is already included in I_{REF+}.
- (4) The temperature sensor offset can be significant. TI recommends a single-point calibration to minimize the offset error of the built-in temperature sensor.
- (5) The typical equivalent impedance of the sensor is 51 kΩ. The sample time required includes the sensor-on time t_{SENSOR(on)}.
- (6) The on-time t_{V_{MID}(on)} is included in the sampling time t_{V_{MID}(sample)}; no additional on time is needed.
- (7) The condition is that the error in a conversion started after t_{REFON} is less than ±0.5 LSB.

5.61 Comparator_B

over recommended ranges of supply voltage and operating free-air temperature (unless otherwise noted)

PARAMETER	TEST CONDITIONS	V _{CC}	MIN	TYP	MAX	UNIT		
V _{CC}	Supply voltage		1.8		3.6	V		
I _{AVCC_COMP}	Comparator operating supply current into AVCC, excludes reference resistor ladder	1.8 V			40	μA		
					22			
					32			
		2.2 V, 3 V		10	30			
	CBPWRMD = 10, CBON = 1, CBR _{Sx} = 00			0.2	0.85			
I _{AVCC_REF}	Quiescent current of resistor ladder into AVCC, includes REF module current	2.2 V, 3 V		10	22	μA		
			CBREFACC = 0, CBREFL _x = 01, CBR _{Sx} = 10, REFON = 0, CBON = 0		33		40	
V _{IC}	Common-mode input range		0		V _{CC} – 1	V		
V _{OFFSET}	Input offset voltage			–20	+20	mV		
			CBPWRMD = 01, 10		–20		+20	
C _{IN}	Input capacitance			5		pF		
R _{SIN}	Series input resistance			3	4	kΩ		
			On (switch closed)					
	Off (switch open)		50			MΩ		
t _{PD}	Propagation delay, response time				450	ns		
					600			
			CBPWRMD = 10, CBF = 0			50	μs	
t _{PD,filter}	Propagation delay with filter active			0.30	0.6	1.5	μs	
			CBPWRMD = 00, CBON = 1, CBF = 1, CBF _{DLY} = 01		0.5	1.0		1.8
			CBPWRMD = 00, CBON = 1, CBF = 1, CBF _{DLY} = 10		0.8	1.8		3.4
			CBPWRMD = 00, CBON = 1, CBF = 1, CBF _{DLY} = 11		1.5	3.4		6.5
t _{EN_CMP}	Comparator enable time			1	2	μs		
			CBON = 0 → 1, CBPWRMD = 00, 01				100	
t _{EN_REF}	Resistor reference enable time			1.0	1.5	μs		
TC _{REF}	Temperature coefficient reference				50	ppm/°C		
V _{CB_REF}	Reference voltage for a given tap	V _{IN} = reference into resistor ladder, n = 0 to 31		V _{IN} × (n + 1.5) / 32	V _{IN} × (n + 1) / 32	V _{IN} × (n + 0.5) / 32	V	

5.62 Flash Memory

over recommended ranges of supply voltage and operating free-air temperature (unless otherwise noted)

PARAMETER		T _J	MIN	TYP	MAX	UNIT
DV _{CC(PGM/ERASE)}	Program and erase supply voltage		1.8		3.6	V
I _{PGM}	Average supply current from DV _{CC} during program			3	5	mA
I _{ERASE}	Average supply current from DV _{CC} during erase			6	15	mA
I _{MERASE} , I _{BANK}	Average supply current from DV _{CC} during mass erase or bank erase			6	15	mA
t _{CPT}	Cumulative program time ⁽¹⁾				16	ms
	Program and erase endurance		10 ⁴	10 ⁵		cycles
t _{Retention}	Data retention duration	25°C	100			years
t _{Word}	Word or byte program time ⁽²⁾		64		85	μs
t _{Block, 0}	Block program time for first byte or word ⁽²⁾		49		65	μs
t _{Block, 1–(N–1)}	Block program time for each additional byte or word, except for last byte or word ⁽²⁾		37		49	μs
t _{Block, N}	Block program time for last byte or word ⁽²⁾		55		73	μs
t _{Erase}	Erase time for segment erase, mass erase, and bank erase when available ⁽²⁾		23		32	ms
f _{MCLK,MGR}	MCLK frequency in marginal read mode (FCTL4.MGR0 = 1 or FCTL4.MGR1 = 1)		0		1	MHz

- (1) The cumulative program time must not be exceeded when writing to a 128-byte flash block. This parameter applies to all programming methods: individual word or byte write and block write modes.
- (2) These values are hardwired into the state machine of the flash controller.

5.63 JTAG and Spy-Bi-Wire Interface

over recommended ranges of supply voltage and operating free-air temperature (unless otherwise noted)

PARAMETER		V _{CC}	MIN	TYP	MAX	UNIT
f _{SBW}	Spy-Bi-Wire input frequency	2.2 V, 3 V	0		20	MHz
t _{SBW,Low}	Spy-Bi-Wire low clock pulse duration	2.2 V, 3 V	0.025		15	μs
t _{SBW,En}	Spy-Bi-Wire enable time (TEST high to acceptance of first clock edge) ⁽¹⁾	2.2 V, 3 V			1	μs
t _{SBW,Rst}	Spy-Bi-Wire return to normal operation time		15		100	μs
f _{TCK}	TCK input frequency for 4-wire JTAG ⁽²⁾	2.2 V	0		5	MHz
		3 V	0		10	MHz
R _{internal}	Internal pulldown resistance on TEST	2.2 V, 3 V	45	60	80	kΩ

- (1) Tools that access the Spy-Bi-Wire interface must wait for the minimum t_{SBW,En} time after pulling the TEST/SBWTCK pin high before applying the first SBWTCK clock edge.
- (2) f_{TCK} may be restricted to meet the timing requirements of the module selected.

6 Detailed Description

6.1 Functional Block Diagrams

Figure 6-1 shows the functional block diagram for all devices in the PEU package.

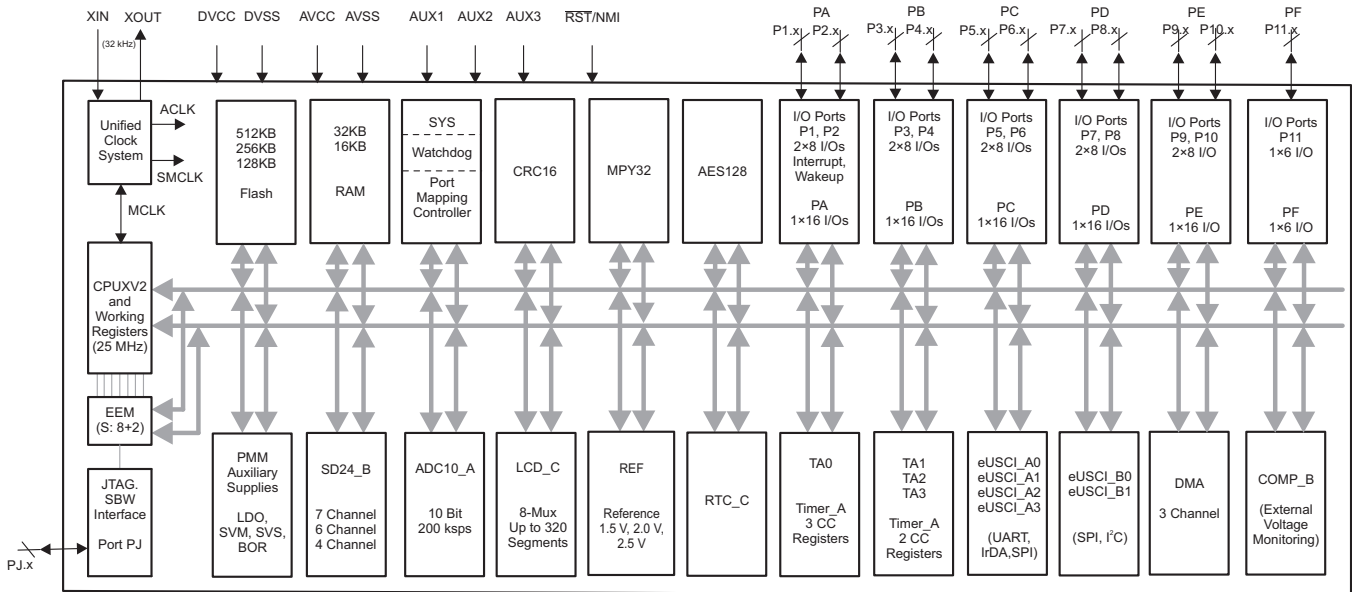

Copyright © 2016, Texas Instruments Incorporated

Figure 6-1. Functional Block Diagram – MSP430F677xIPEU, MSP430F676xIPEU, and MSP430F674xIPEU

Figure 6-2 shows the functional block diagram for all devices in the PZ package.

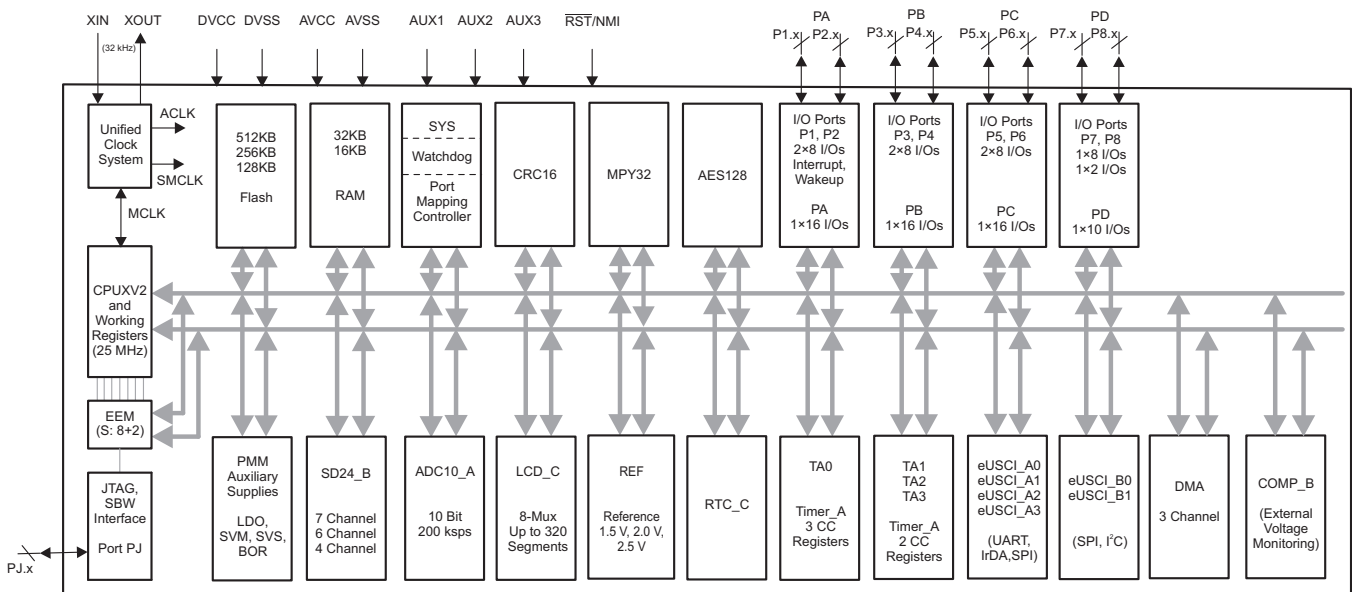

Copyright © 2016, Texas Instruments Incorporated

Figure 6-2. Functional Block Diagram – MSP430F677xIPZ, MSP430F676xIPZ, and MSP430F674xIPZ

6.2 CPU ([Link to User's Guide](#))

The MSP430 CPU has a 16-bit RISC architecture that is highly transparent to the application. All operations, other than program-flow instructions, are performed as register operations in conjunction with seven addressing modes for source operand and four addressing modes for destination operand.

The CPU is integrated with 16 registers that provide reduced instruction execution time. The register-to-register operation execution time is one cycle of the CPU clock. Four of the registers, R0 to R3, are dedicated as program counter, stack pointer, status register, and constant generator, respectively. The remaining registers are general-purpose registers (see [Figure 6-3](#)).

Peripherals are connected to the CPU using data, address, and control buses. Peripherals can be managed with all instructions.

Program Counter	PC/R0
Stack Pointer	SP/R1
Status Register	SR/CG1/R2
Constant Generator	CG2/R3
General-Purpose Register	R4
General-Purpose Register	R5
General-Purpose Register	R6
General-Purpose Register	R7
General-Purpose Register	R8
General-Purpose Register	R9
General-Purpose Register	R10
General-Purpose Register	R11
General-Purpose Register	R12
General-Purpose Register	R13
General-Purpose Register	R14
General-Purpose Register	R15

Figure 6-3. CPU Registers

6.3 Instruction Set

The instruction set consists of the original 51 instructions with three formats and seven address modes and additional instructions for the expanded address range. Each instruction can operate on word and byte data. [Table 6-1](#) lists examples of the three types of instruction formats. [Table 6-2](#) lists the address modes.

Table 6-1. Instruction Word Formats

INSTRUCTION WORD FORMAT	EXAMPLE	OPERATION
Dual operands, source and destination	ADD R4,R5	R4 + R5 → R5
Single operands, destination only	CALL R8	PC → (TOS), R8 → PC
Relative jump, unconditional or conditional	JNE	Jump-on-equal bit = 0

Table 6-2. Address Mode Descriptions

ADDRESS MODE	S ⁽¹⁾	D ⁽¹⁾	SYNTAX	EXAMPLE	OPERATION
Register	+	+	MOV Rs,Rd	MOV R10,R11	R10 → R11
Indexed	+	+	MOV X(Rn),Y(Rm)	MOV 2(R5),6(R6)	M(2+R5) → M(6+R6)
Symbolic (PC relative)	+	+	MOV EDE,TONI		M(EDE) → M(TONI)
Absolute	+	+	MOV & MEM, & TCDAT		M(MEM) → M(TCDAT)
Indirect	+		MOV @Rn,Y(Rm)	MOV @R10,Tab(R6)	M(R10) → M(Tab+R6)
Indirect autoincrement	+		MOV @Rn+,Rm	MOV @R10+,R11	M(R10) → R11 R10 + 2 → R10
Immediate	+		MOV #X,TONI	MOV #45,TONI	#45 → M(TONI)

(1) S = source, D = destination

6.4 Operating Modes

These microcontrollers have one active mode and seven software-selectable low-power modes of operation. An interrupt event can wake up the device from any of the five low-power modes, service the request, and restore back to the low-power mode on return from the interrupt program.

Software can configure the following operating modes:

- Active mode (AM)
 - All clocks are active
- Low-power mode 0 (LPM0)
 - CPU is disabled
 - ACLK and SMCLK remain active, MCLK is disabled
 - FLL loop control remains active
- Low-power mode 1 (LPM1)
 - CPU is disabled
 - FLL loop control is disabled
 - ACLK and SMCLK remain active, MCLK is disabled
- Low-power mode 2 (LPM2)
 - CPU is disabled
 - MCLK and FLL loop control and DCOCLK are disabled
 - DC generator of the DCO remains enabled
 - ACLK remains active
- Low-power mode 3 (LPM3)
 - CPU is disabled
 - MCLK, FLL loop control, and DCOCLK are disabled
 - DC generator of the DCO is disabled
 - ACLK remains active
- Low-power mode 4 (LPM4)
 - CPU is disabled
 - ACLK is disabled
 - MCLK, FLL loop control, and DCOCLK are disabled
 - DC generator of the DCO is disabled
 - Crystal oscillator is stopped
 - Complete data retention
- Low-power mode 3.5 (LPM3.5)
 - Internal regulator disabled
 - No RAM retention, backup RAM retained
 - I/O pad state retention
 - RTC clocked by low-frequency oscillator
 - Wake-up input from $\overline{\text{RST}}$ /NMI, RTC_C events, Ports P1 and P2
- Low-power mode 4.5 (LPM4.5)
 - Internal regulator disabled
 - No RAM retention, backup RAM retained
 - RTC is disabled
 - I/O pad state retention
 - Wake-up input from $\overline{\text{RST}}$ /NMI, Ports P1 and P2

6.5 Interrupt Vector Addresses

The interrupt vectors and the power-up start address are in the address range 0FFFFh to 0FF80h (see [Table 6-3](#)). The vector contains the 16-bit address of the appropriate interrupt-handler instruction sequence.

Table 6-3. Interrupt Sources, Flags, and Vectors

INTERRUPT SOURCE	INTERRUPT FLAG	SYSTEM INTERRUPT	WORD ADDRESS	PRIORITY
System Reset Power up External reset Watchdog time-out, key violation Flash memory key violation	WDTIFG, KEYV (SYSRSTIV) ^{(1) (2)}	Reset	0FFFEh	63, highest
System NMI PMM Vacant memory access JTAG mailbox	SVMLIFG, SVMHIFG, DLYLIFG, DLYHIFG, VLRLIFG, VLRHIFG, VMAIFG, JMBNIFG, JMBOUTIFG (SYSSNIV) ^{(1) (3)}	(Non)maskable	0FFFCh	62
User NMI NMI Oscillator fault Flash memory access violation Supply switched	NMIIFG, OFIFG, ACCVIFG, AUXSWGIFG (SYSUNIV) ^{(1) (3)}	(Non)maskable	0FFFAh	61
Watchdog Timer_A interval timer mode	WDTIFG	Maskable	0FFF8h	60
eUSCI_A0 receive or transmit	UCA0RXIFG, UCA0TXIFG (UCA0IV) ^{(1) (4)}	Maskable	0FFF6h	59
eUSCI_B0 receive or transmit	UCB0RXIFG, UCB0TXIFG (UCB0IV) ^{(1) (4)}	Maskable	0FFF4h	58
ADC10_A	ADC10IFG0, ADC10INIFG, ADC10LOIFG, ADC10HIIFG, ADC10TOVIFG, ADC10OVIFG (ADC10IV) ^{(1) (4)}	Maskable	0FFF2h	57
SD24_B	SD24_B Interrupt Flags (SD24IV) ^{(1) (4)}	Maskable	0FFF0h	56
Timer TA0	TA0CCR0 CCIFG0 ⁽⁴⁾	Maskable	0FFEEh	55
Timer TA0	TA0CCR1 CCIFG1, TA0CCR2 CCIFG2, TA0IFG (TA0IV) ^{(1) (4)}	Maskable	0FFECCh	54
eUSCI_A1 receive or transmit	UCA1RXIFG, UCA1TXIFG (UCA1IV) ^{(1) (4)}	Maskable	0FFEAh	53
eUSCI_A2 receive or transmit	UCA2RXIFG, UCA2TXIFG (UCA2IV) ^{(1) (4)}	Maskable	0FFE8h	52
Auxiliary supplies	AUXSWGIFG, AUXIFG0, AUXIFG1, AUXIFG2 (AUXIV) ^{(1) (4)}	Maskable	0FFE6h	51
DMA	DMA0IFG, DMA1IFG, DMA2IFG (DMAIV) ^{(1) (4)}	Maskable	0FFE4h	50
Timer TA1	TA1CCR0 CCIFG0 ⁽⁴⁾	Maskable	0FFE2h	49
Timer TA1	TA1CCR1 CCIFG1, TA1IFG (TA1IV) ^{(1) (4)}	Maskable	0FFE0h	48
eUSCI_A3 receive or transmit	UCA3RXIFG, UCA3TXIFG (UCA3IV) ^{(1) (4)}	Maskable	0FFDEh	47
eUSCI_B1 receive or transmit	UCB1RXIFG, UCB1TXIFG (UCB1IV) ^{(1) (4)}	Maskable	0FFDCh	46
I/O port P1	P1IFG.0 to P1IFG.7 (P1IV) ^{(1) (4)}	Maskable	0FFDAh	45
Timer TA2	TA2CCR0 CCIFG0 ⁽⁴⁾	Maskable	0FFD8h	44
Timer TA2	TA2CCR1 CCIFG1, TA2IFG (TA2IV) ^{(1) (4)}	Maskable	0FFD6h	43
I/O port P2	P2IFG.0 to P2IFG.7 (P2IV) ^{(1) (4)}	Maskable	0FFD4h	42
Timer TA3	TA3CCR0 CCIFG0 ⁽⁴⁾	Maskable	0FFD2h	41
Timer TA3	TA3CCR1 CCIFG1, TA3IFG (TA3IV) ^{(1) (4)}	Maskable	0FFD0h	40
LCD_C	LCD_C Interrupt Flags (LCDCIV) ^{(1) (4)}	Maskable	0FFCEh	39

(1) Multiple source flags

(2) A reset is generated if the CPU tries to fetch instructions from within peripheral space or vacant memory space.

(3) (Non)maskable: the individual interrupt enable bit can disable an interrupt event, but the general interrupt enable bit cannot disable it.

(4) Interrupt flags are in the module.

Table 6-3. Interrupt Sources, Flags, and Vectors (continued)

INTERRUPT SOURCE	INTERRUPT FLAG	SYSTEM INTERRUPT	WORD ADDRESS	PRIORITY
RTC_C	RTCOFIG, RTCRDYIFG, RTCTEVIFG, RTCAIFG, RT0PSIFG, RT1PSIFG (RTCIV) ^{(1) (4)}	Maskable	0FFCCh	38
Comparator_B	Comparator_B Interrupt Flags (CBIV) ⁽¹⁾	Maskable	0FFCAh	37
AES	AESRDYIFG	Maskable	0FFC8h	36
Reserved	Reserved ⁽⁵⁾		0FFC6h	35
			:	:
			0FF80h	0, lowest

(5) Reserved interrupt vectors at addresses are not used in this device and can be used for regular program code if necessary. To maintain compatibility with other devices, TI recommends reserving these locations.

6.6 Special Function Registers (SFRs)

The MSP430 SFRs are in the lowest address space and can be accessed in word or byte formats.

Legend

rw	Bit can be read and written.
rw-0, rw-1	Bit can be read and written. It is reset or set by PUC.
rw-(0), rw-(1)	Bit can be read and written. It is reset or set by POR.
rw-[0], rw-[1]	Bit can be read and written. It is reset or set by BOR.
–	SFR bit is not present in device.

Figure 6-4. Interrupt Enable 1 Register

15	14	13	12	11	10	9	8
–	–	–	–	–	–	AUXSWNMIE	–
rw-0							
7	6	5	4	3	2	1	0
JMBOUTIE	JMBINIE	ACCVIE	NMIIE	VMAIE	–	OFIE	WDTIE
rw-0	rw-0	rw-0	rw-0	rw-0		rw-0	rw-0

Table 6-4. Interrupt Enable 1 Register Description

BIT	FIELD	TYPE	RESET	DESCRIPTION
9	AUXSWNMIE	RW	0h	Supply switched nonmaskable interrupt enable
7	JMBOUTIE	RW	0h	JTAG mailbox output interrupt enable
6	JMBINIE	RW	0h	JTAG mailbox input interrupt enable
5	ACCVIE	RW	0h	Flash access violation interrupt enable
4	NMIIE	RW	0h	Nonmaskable interrupt enable
3	VMAIE	RW	0h	Vacant memory access interrupt enable
1	OFIE	RW	0h	Oscillator fault interrupt enable
0	WDTIE	RW	0h	Watchdog timer interrupt enable. Inactive if watchdog mode is selected. Active if watchdog timer is configured as a general-purpose timer.

Figure 6-5. Interrupt Flag 1 Register

15	14	13	12	11	10	9	8
–	–	–	–	–	–	–	–
rw-0							
7	6	5	4	3	2	1	0
JMBOUTIFG	JMBINIFG	–	NMIIFG	VMAIFG	–	OFIFG	WDTIFG
rw-[0]	rw-[0]		rw-0	rw-0		rw-0	rw-0

Table 6-5. Interrupt Flag 1 Register Description

BIT	FIELD	TYPE	RESET	DESCRIPTION
7	JMBOUTIFG	RW	0h	Set on JTAG mailbox output register ready for next message
6	JMBINIFG	RW	0h	Set on JTAG mailbox input message
4	NMIIFG	RW	0h	Set by \overline{RST}/NMI pin
3	VMAIFG	RW	0h	Set on vacant memory access
1	OFIFG	RW	0h	Flag set on oscillator fault
0	WDTIFG	RW	0h	Set on watchdog timer overflow (in watchdog mode) or security key violation. Reset on V_{CC} power-on or a reset condition at the \overline{RST}/NMI pin in reset mode.

6.7 Memory Organization

Table 6-6 and Table 6-7 summarize the memory map for the devices.

Table 6-6. Memory Organization

		MSP430F6779 MSP430F6769 MSP430F6749	MSP430F6778 MSP430F6768 MSP430F6748	MSP430F6777 MSP430F6767 MSP430F6747
Main memory (flash)	Total Size	512KB	512KB	256KB
Main: interrupt vector		00FFFFh to 00FF80h	00FFFFh to 00FF80h	00FFFFh to 00FF80h
Main: code memory	Bank 3	128KB 08BFFFh to 06C000h	128KB 08BFFFh to 06C000h	not available
	Bank 2	128KB 06BFFFh to 04C000h	128KB 06BFFFh to 04C000h	not available
	Bank 1	128KB 04BFFFh to 02C000h	128KB 04BFFFh to 02C000h	128KB 04BFFFh to 02C000h
	Bank 0	128KB 02BFFFh to 00C000h	128KB 02BFFFh to 00C000h	128KB 02BFFFh to 00C000h
RAM	Total Size	32KB	16KB	32KB
	Sector 7	4KB 009BFFFh to 008C00h	not available	4KB 009BFFFh to 008C00h
	Sector 6	4KB 008BFFFh to 007C00h	not available	4KB 008BFFFh to 007C00h
	Sector 5	4KB 007BFFFh to 006C00h	not available	4KB 007BFFFh to 006C00h
	Sector 4	4KB 006BFFFh to 005C00h	not available	4KB 006BFFFh to 005C00h
	Sector 3	4KB 005BFFFh to 004C00h	4KB 005BFFFh to 004C00h	4KB 005BFFFh to 004C00h
	Sector 2	4KB 004BFFFh to 003C00h	4KB 004BFFFh to 003C00h	4KB 004BFFFh to 003C00h
	Sector 1	4KB 003BFFFh to 002C00h	4KB 003BFFFh to 002C00h	4KB 003BFFFh to 002C00h
	Sector 0	4KB 002BFFFh to 001C00h	4KB 002BFFFh to 001C00h	4KB 002BFFFh to 001C00h
Device descriptor		128 B 001AFFh to 001A80h	128 B 001AFFh to 001A80h	128 B 001AFFh to 001A80h
		128 B 001A7Fh to 001A00h	128 B 001A7Fh to 001A00h	128 B 001A7Fh to 001A00h
Information memory (flash)	Info A	128 B 0019FFh to 001980h	128 B 0019FFh to 001980h	128 B 0019FFh to 001980h
	Info B	128 B 00197Fh to 001900h	128 B 00197Fh to 001900h	128 B 00197Fh to 001900h
	Info C	128 B 0018FFh to 001880h	128 B 0018FFh to 001880h	128 B 0018FFh to 001880h
	Info D	128 B 00187Fh to 001800h	128 B 00187Fh to 001800h	128 B 00187Fh to 001800h
Bootloader (BSL) memory (flash)	BSL 3	512 B 0017FFh to 001600h	512 B 0017FFh to 001600h	512 B 0017FFh to 001600h
	BSL 2	512 B 0015FFh to 001400h	512 B 0015FFh to 001400h	512 B 0015FFh to 001400h
	BSL 1	512 B 0013FFh to 001200h	512 B 0013FFh to 001200h	512 B 0013FFh to 001200h
	BSL 0	512 B 0011FFh to 001000h	512 B 0011FFh to 001000h	512 B 0011FFh to 001000h
Peripherals		4KB 000FFFh to 0h	4KB 000FFFh to 0h	4KB 000FFFh to 0h

Table 6-7. Memory Organization

		MSP430F6776 MSP430F6766 MSP430F6746	MSP430F6775 MSP430F6765 MSP430F6745
Main memory (flash)	Total Size	256KB	128KB
Main: interrupt vector		00FFFFh to 00FF80h	00FFFFh to 00FF80h
Main: code memory	Bank 3	not available	not available
	Bank 2	not available	not available
	Bank 1	128KB 04BFFFh to 02C000h	not available
	Bank 0	128KB 02BFFFh to 00C000h	128KB 02BFFFh to 00C000h
RAM	Total Size	16KB	16KB
	Sector 7	not available	not available
	Sector 6	not available	not available
	Sector 5	not available	not available
	Sector 4	not available	not available
	Sector 3	4KB 005BFFFh to 004C00h	4KB 005BFFFh to 004C00h
	Sector 2	4KB 004BFFFh to 003C00h	4KB 004BFFFh to 003C00h
	Sector 1	4KB 003BFFFh to 002C00h	4KB 003BFFFh to 002C00h
Device descriptor		128 B 001AFFh to 001A80h	128 B 001AFFh to 001A80h
		128 B 001A7Fh to 001A00h	128 B 001A7Fh to 001A00h
Information memory (flash)	Info A	128 B 0019FFh to 001980h	128 B 0019FFh to 001980h
	Info B	128 B 00197Fh to 001900h	128 B 00197Fh to 001900h
	Info C	128 B 0018FFh to 001880h	128 B 0018FFh to 001880h
	Info D	128 B 00187Fh to 001800h	128 B 00187Fh to 001800h
Bootloader (BSL) memory (flash)	BSL 3	512 B 0017FFh to 001600h	512 B 0017FFh to 001600h
	BSL 2	512 B 0015FFh to 001400h	512 B 0015FFh to 001400h
	BSL 1	512 B 0013FFh to 001200h	512 B 0013FFh to 001200h
	BSL 0	512 B 0011FFh to 001000h	512 B 0011FFh to 001000h
Peripherals		4KB 000FFFh to 0h	4KB 000FFFh to 0h

6.8 Bootloader (BSL)

The BSL lets users program the flash memory or RAM using various serial interfaces. Access to the device memory through the BSL is protected by a user-defined password. BSL entry requires a specific entry sequence on the $\overline{\text{RST}}$ /NMI/SBWDIO and TEST/SBWTCK pins. For a complete description of the features of the BSL and its implementation, see [MSP430™ Flash Device Bootloader \(BSL\) User's Guide](#). [Table 6-8](#) lists the BSL pin requirements.

Table 6-8. UART BSL Pin Requirements and Functions

DEVICE SIGNAL	BSL FUNCTION
$\overline{\text{RST}}$ /NMI/SBWDIO	Entry sequence signal
TEST/SBWTCK	Entry sequence signal
P2.0	Data transmit
P2.1	Data receive
DVCC	Power supply
DVSS	Ground supply

6.9 JTAG Operation

6.9.1 JTAG Standard Interface

The MSP430 family supports the standard JTAG interface which requires four signals for sending and receiving data. The JTAG signals are shared with general-purpose I/O. The TEST/SBWTCK pin is used to enable the JTAG signals. In addition to these signals, the $\overline{\text{RST}}$ /NMI/SBWDIO is required to interface with MSP430 development tools and device programmers. [Table 6-9](#) lists the JTAG pin requirements. For further details on interfacing to development tools and device programmers, see the [MSP430 Hardware Tools User's Guide](#). For a complete description of the features of the JTAG interface and its implementation, see [MSP430 Programming With the JTAG Interface](#).

Table 6-9. JTAG Pin Requirements and Functions

DEVICE SIGNAL	DIRECTION	FUNCTION
PJ.3/TCK	IN	JTAG clock input
PJ.2/TMS	IN	JTAG state control
PJ.1/TDI/TCLK	IN	JTAG data input, TCLK input
PJ.0/TDO	OUT	JTAG data output
TEST/SBWTCK	IN	Enable JTAG pins
$\overline{\text{RST}}$ /NMI/SBWDIO	IN	External reset
DVCC		Power supply
DVSS		Ground supply

6.9.2 Spy-Bi-Wire Interface

In addition to the standard JTAG interface, the MSP430 family supports the 2-wire Spy-Bi-Wire interface. Spy-Bi-Wire can be used to interface with MSP430 development tools and device programmers. [Table 6-10](#) lists the Spy-Bi-Wire interface pin requirements. For further details on interfacing to development tools and device programmers, see the [MSP430 Hardware Tools User's Guide](#). For a complete description of the features of the JTAG interface and its implementation, see [MSP430 Programming With the JTAG Interface](#).

Table 6-10. Spy-Bi-Wire Pin Requirements and Functions

DEVICE SIGNAL	DIRECTION	FUNCTION
TEST/SBWTCK	IN	Spy-Bi-Wire clock input
$\overline{\text{RST}}$ /NMI/SBWDIO	IN, OUT	Spy-Bi-Wire data input and output
VCC		Power supply
VSS		Ground supply

6.10 Flash Memory ([Link to User's Guide](#))

The flash memory can be programmed through the JTAG port, Spy-Bi-Wire (SBW), the BSL, or in-system by the CPU. The CPU can perform single-byte, single-word, and long-word writes to the flash memory. Features of the flash memory include:

- Flash memory has n segments of main memory and four segments of information memory (A to D) of 128 bytes each. Each segment in main memory is 512 bytes.
- Segments 0 to n may be erased in one step, or each segment may be individually erased.
- Segments A to D can be erased individually, or as a group with segments 0 to n. Segments A to D are also called *information memory*.
- Segment A can be locked separately.

6.11 RAM ([Link to User's Guide](#))

The RAM is made up of n sectors. Each sector can be completely powered down to save leakage; however, all data are lost. Features of the RAM include:

- RAM has n sectors of 4KB each.
- Each sector 0 to n can be completely disabled; however, data retention is lost.
- Each sector 0 to n automatically enters low-power retention mode when possible.

6.12 Backup RAM ([Link to User's Guide](#))

The backup RAM provides a limited number of bytes of RAM that are retained during LPM3.5. This backup RAM is part of the backup subsystem that operates on dedicated power supply AUXVCC3. Eight bytes of backup RAM are available in this device. The backup RAM can be word-wise accessed through the registers BAKMEM0, BAKMEM1, BAKMEM2, and BAKMEM3. The backup RAM registers cannot be accessed by CPU when the high-side SVS is disabled by the user application.

6.13 Peripherals

Peripherals are connected to the CPU through data, address, and control buses. The peripherals can be managed using all instructions. For complete module descriptions, see the [MSP430x5xx and MSP430x6xx Family User's Guide](#).

6.13.1 Oscillator and System Clock ([Link to User's Guide](#))

The Unified Clock System (UCS) module includes support for a 32768-Hz watch crystal oscillator, an internal very-low-power low-frequency oscillator (VLO), an internal trimmed low-frequency oscillator (REFO), and an integrated internal digitally controlled oscillator (DCO). The UCS module is designed to meet the requirements of both low system cost and low power consumption. The UCS module features digital frequency-locked loop (FLL) hardware that, in conjunction with a digital modulator, stabilizes the DCO frequency to a programmable multiple of the selected FLL reference frequency. The internal DCO provides a fast turnon clock source and stabilizes in less than 5 μ s. The UCS module provides the following clock signals:

- Auxiliary clock (ACLK), sourced from a 32768-Hz watch crystal, the internal low-frequency oscillator (VLO), or the trimmed low-frequency oscillator (REFO).
- Main clock (MCLK), the system clock used by the CPU. MCLK can be sourced by same sources made available to ACLK.
- Sub-Main clock (SMCLK), the subsystem clock used by the peripheral modules. SMCLK can be sourced by same sources made available to ACLK.
- ACLK/n, the buffered output of ACLK, ACLK/2, ACLK/4, ACLK/8, ACLK/16, ACLK/32.

6.13.2 Power-Management Module (PMM) ([Link to User's Guide](#))

The PMM includes an integrated voltage regulator that supplies the core voltage to the device and contains programmable output levels to provide for power optimization. The PMM also includes supply voltage supervisor (SVS) and supply voltage monitoring (SVM) circuitry, as well as brownout protection. The brownout circuit is implemented to provide the proper internal reset signal to the device during power on and power off. The SVS and SVM circuitry detects if the supply voltage drops below a user-selectable level and supports both supply voltage supervision (the device is automatically reset) and supply voltage monitoring (the device is not automatically reset). SVS and SVM circuitry is available on the primary supply and core supply.

6.13.3 Auxiliary Supply System ([Link to User's Guide](#))

The auxiliary supply system provides the option to operate the device from auxiliary supplies when the primary supply fails. Two auxiliary supplies (AUXVCC1 and AUXVCC2) are supported in the MSP430F67xx MCUs. The auxiliary supply system supports automatic and manual switching from primary supply to auxiliary supplies while maintaining full functionality. The auxiliary supply system allows threshold-based monitoring of primary and auxiliary supplies. The device can be started from primary supply or AUXVCC1, whichever is higher. Auxiliary supply system enables internal monitoring of voltage levels on primary and auxiliary supplies using ADC10_A. This module also implements a simple charger for backup capacitors.

6.13.4 Backup Subsystem

The backup subsystem operates on a dedicated power supply AUXVCC3. This subsystem includes a low-frequency oscillator, the RTC module, and backup RAM. The functionality of the backup subsystem is retained during LPM3.5. The backup subsystem module registers cannot be accessed by the CPU when the high-side SVS is disabled.

6.13.5 Digital I/O ([Link to User's Guide](#))

Up to eleven 8-bit I/O ports are implemented. For 128-pin options, ports P1 to P10 are complete, and port P11 is 6 bits wide. For 100-pin options, ports P1 to P7 are complete, port P8 is 2 bits wide, and ports P9, P10, and P11 are completely removed. Port PJ contains four individual I/O pins, common to all devices. All I/O bits are individually programmable.

- Any combination of input, output, and interrupt conditions is possible.
- Programmable pullup or pulldown on all ports.
- Programmable drive strength on all ports.
- Edge-selectable interrupt and LPM3.5, LPM4.5 wake-up input capability available for all bits of ports P1 and P2.
- Read-write access to port-control registers is supported by all instructions.
- Ports can be accessed byte-wise (P1 to P11) or word-wise in pairs (PA to PF).

6.13.6 Port Mapping Controller ([Link to User's Guide](#))

The port mapping controller allows flexible and reconfigurable mapping of digital functions to ports P2, P3, and P4 (see [Table 6-11](#)). [Table 6-12](#) lists the default settings for all pins that support port mapping.

Table 6-11. Port Mapping Mnemonics and Functions

VALUE	PxMAPy MNEMONIC	INPUT PIN FUNCTION	OUTPUT PIN FUNCTION
0	PM_NONE	None	DVSS
1	PM_UCA0RXD	eUSCI_A0 UART RXD (direction controlled by eUSCI – Input)	
	PM_UCA0SOMI	eUSCI_A0 SPI slave out master in (direction controlled by eUSCI)	
2	PM_UCA0TXD	eUSCI_A0 UART TXD (direction controlled by eUSCI – Output)	
	PM_UCA0SIMO	eUSCI_A0 SPI slave in master out (direction controlled by eUSCI)	
3	PM_UCA0CLK	eUSCI_A0 clock input/output (direction controlled by eUSCI)	
4	PM_UCA0STE	eUSCI_A0 SPI slave transmit enable (direction controlled by eUSCI)	
5	PM_UCA1RXD	eUSCI_A1 UART RXD (direction controlled by eUSCI – Input)	
	PM_UCA1SOMI	eUSCI_A1 SPI slave out master in (direction controlled by eUSCI)	
6	PM_UCA1TXD	eUSCI_A1 UART TXD (direction controlled by eUSCI – Output)	
	PM_UCA1SIMO	eUSCI_A1 SPI slave in master out (direction controlled by eUSCI)	
7	PM_UCA1CLK	eUSCI_A1 clock input/output (direction controlled by eUSCI)	
8	PM_UCA1STE	eUSCI_A1 SPI slave transmit enable (direction controlled by eUSCI)	
9	PM_UCA2RXD	eUSCI_A2 UART RXD (direction controlled by eUSCI – Input)	
	PM_UCA2SOMI	eUSCI_A2 SPI slave out master in (direction controlled by eUSCI)	
10	PM_UCA2TXD	eUSCI_A2 UART TXD (direction controlled by eUSCI – Output)	
	PM_UCA2SIMO	eUSCI_A2 SPI slave in master out (direction controlled by eUSCI)	
11	PM_UCA2CLK	eUSCI_A2 clock input/output (direction controlled by eUSCI)	
12	PM_UCA2STE	eUSCI_A2 SPI slave transmit enable (direction controlled by eUSCI)	
13	PM_UCA3RXD	eUSCI_A3 UART RXD (direction controlled by eUSCI – Input)	
	PM_UCA3SOMI	eUSCI_A3 SPI slave out master in (direction controlled by eUSCI)	
14	PM_UCA3TXD	eUSCI_A3 UART TXD (direction controlled by eUSCI – Output)	
	PM_UCA3SIMO	eUSCI_A3 SPI slave in master out (direction controlled by eUSCI)	
15	PM_UCA3CLK	eUSCI_A3 clock input/output (direction controlled by eUSCI)	
16	PM_UCA3STE	eUSCI_A3 SPI slave transmit enable (direction controlled by eUSCI)	
17	PM_UCB0SIMO	eUSCI_B0 SPI slave in master out (direction controlled by eUSCI)	
	PM_UCB0SDA	eUSCI_B0 I ² C data (open drain and direction controlled by eUSCI)	
18	PM_UCB0SOMI	eUSCI_B0 SPI slave out master in (direction controlled by eUSCI)	
	PM_UCB0SCL	eUSCI_B0 I ² C clock (open drain and direction controlled by eUSCI)	
19	PM_UCB0CLK	eUSCI_B0 clock input/output (direction controlled by eUSCI)	
20	PM_UCB0STE	eUSCI_B0 SPI slave transmit enable (direction controlled by eUSCI)	

Table 6-11. Port Mapping Mnemonics and Functions (continued)

VALUE	PxMAPy MNEMONIC	INPUT PIN FUNCTION	OUTPUT PIN FUNCTION
21	PM_UCB1SIMO	eUSCI_B1 SPI slave in master out (direction controlled by eUSCI)	
	PM_UCB1SDA	eUSCI_B1 I ² C data (open drain and direction controlled by eUSCI)	
22	PM_UCB1SOMI	eUSCI_B1 SPI slave out master in (direction controlled by eUSCI)	
	PM_UCB1SCL	eUSCI_B1 I ² C clock (open drain and direction controlled by eUSCI)	
23	PM_UCB1CLK	eUSCI_B1 clock input/output (direction controlled by eUSCI)	
24	PM_UCB1STE	eUSCI_B1 SPI slave transmit enable (direction controlled by eUSCI)	
25	PM_TA0.0	TA0 CCR0 capture input CCI0A	TA0 CCR0 compare output Out0
26	PM_TA0.1	TA0 CCR1 capture input CCI1A	TA0 CCR1 compare output Out1
27	PM_TA0.2	TA0 CCR2 capture input CCI2A	TA0 CCR2 compare output Out2
28	PM_TA1.0	TA1 CCR0 capture input CCI0A	TA1 CCR0 compare output Out0
29	PM_TA2.0	TA2 CCR0 capture input CCI0A	TA2 CCR0 compare output Out0
30	PM_TA3.0	TA3 CCR0 capture input CCI0A	TA3 CCR0 compare output Out0
31(0FFh) ⁽¹⁾	PM_ANALOG	Disables the output driver and the input Schmitt trigger to prevent parasitic cross currents when applying analog signals.	

(1) The value of the PM_ANALOG mnemonic is set to 0FFh. The port mapping registers are only 5 bits wide and the upper bits are ignored, which results in a read value of 31.

Table 6-12. Default Port Mapping

PIN NAME		PxMAPy MNEMONIC	INPUT PIN FUNCTION	OUTPUT PIN FUNCTION
PEU	PZ			
P2.0/PM_TA0.0	P2.0/PM_TA0.0/COM4	PM_TA0.0	TA0 CCR0 capture input CCI0A	TA0 CCR0 compare output Out0
P2.1/PM_TA0.1	P2.1/PM_TA0.1/COM5	PM_TA0.1	TA0 CCR1 capture input CCI1A	TA0 CCR1 compare output Out1
P2.2/PM_TA0.2	P2.2/PM_TA0.2/COM6	PM_TA0.2	TA0 CCR2 capture input CCI2A	TA0 CCR2 compare output Out2
P2.3/PM_TA1.0	P2.3/PM_TA1.0/COM7	PM_TA1.0	TA1 CCR0 capture input CCI0A	TA1 CCR0 compare output Out0
P2.4/PM_TA2.0	P1.1/PM_TA2.0/R23	PM_TA2.0	TA2 CCR0 capture input CCI0A	TA2 CCR0 compare output Out0
P2.5/PM_UCB0SOMI/ PM_UCB0SCL	P2.0/PM_UCB0SOMI/ PM_UCB0SCL/R13	PM_UCB0SOMI/ PM_UCB0SCL	eUSCI_B0 SPI slave out master in (direction controlled by eUSCI), eUSCI_B0 I ² C clock (open drain and direction controlled by eUSCI)	
P2.6/PM_UCB0SIMO/ PM_UCB0SDA	P2.6/PM_UCB0SIMO/ PM_UCB0SDA/R03	PM_UCB0SIMO/ PM_UCB0SDA	eUSCI_B0 SPI slave in master out (direction controlled by eUSCI), eUSCI_B0 I ² C data (open drain and direction controlled by eUSCI)	
P2.7/PM_UCB0CLK	P2.7/PM_UCB0CLK/CB2	PM_UCB0CLK	eUSCI_B0 clock input/output (direction controlled by eUSCI)	
P3.0/PM_UCA0RXD/ PM_UCA0SOMI	P3.0/PM_UCA0RXD/ PM_UCA0SOMI	PM_UCA0RXD/ PM_UCA0SOMI	eUSCI_A0 UART RXD (direction controlled by eUSCI – input), eUSCI_A0 SPI slave out master in (direction controlled by eUSCI)	
P3.1/PM_UCA0TXD/ PM_UCA0SIMO	P3.1/PM_UCA0TXD/ PM_UCA0SIMO/S39	PM_UCA0TXD/ PM_UCA0SIMO	eUSCI_A0 UART TXD (direction controlled by eUSCI – output), eUSCI_A0 SPI slave in master out (direction controlled by eUSCI)	
P3.2/PM_UCA0CLK	P3.2/PM_UCA0CLK/S38	PM_UCA0CLK	eUSCI_A0 clock input/output (direction controlled by eUSCI)	
P3.3/PM_UCA1CLK	P3.3/PM_UCA1CLK/S37	PM_UCA1CLK	eUSCI_A1 clock input/output (direction controlled by eUSCI)	
P3.4/PM_UCA1RXD/ PM_UCA1SOMI/	P3.4/PM_UCA1RXD/ PM_UCA1SOMI/S36	PM_UCA1RXD/ PM_UCA1SOMI	eUSCI_A1 UART RXD (direction controlled by eUSCI – input), eUSCI_A1 SPI slave out master in (direction controlled by eUSCI)	
P3.5/PM_UCA1TXD/ PM_UCA1SIMO	P3.5/PM_UCA1TXD/ PM_UCA1SIMO/S35	PM_UCA1TXD/ PM_UCA1SIMO	eUSCI_A1 UART TXD (direction controlled by eUSCI – output), eUSCI_A1 SPI slave in master out (direction controlled by eUSCI)	
P3.6/PM_UCA2RXD/ PM_UCA2SOMI/	P3.6/PM_UCA2RXD/ PM_UCA2SOMI/S34	PM_UCA2RXD/ PM_UCA2SOMI	eUSCI_A2 UART RXD (direction controlled by eUSCI – input), eUSCI_A2 SPI slave out master in (direction controlled by eUSCI)	
P3.7/PM_UCA2TXD/ PM_UCA2SIMO	P3.7/PM_UCA2TXD/ PM_UCA2SIMO/S33	PM_UCA2TXD/ PM_UCA2SIMO	eUSCI_A2 UART TXD (direction controlled by eUSCI – output), eUSCI_A2 SPI slave in master out (direction controlled by eUSCI)	
P4.0/PM_UCA2CLK	P4.0/PM_UCA2CLK/S32	PM_UCA2CLK	eUSCI_A2 clock input/output (direction controlled by eUSCI)	
P4.1/PM_UCA3RXD/ PM_UCA3SOMI/	P4.1/PM_UCA3RXD/ PM_UCA3SOMI/S31	PM_UCA3RXD/ PM_UCA3SOMI	eUSCI_A3 UART RXD (direction controlled by eUSCI – input), eUSCI_A3 SPI slave out master in (direction controlled by eUSCI)	
P4.2/PM_UCA3TXD/ PM_UCA3SIMO	P4.2/PM_UCA3TXD/ PM_UCA3SIMO/S30	PM_UCA3TXD/ PM_UCA3SIMO	eUSCI_A3 UART TXD (direction controlled by eUSCI – output), eUSCI_A3 SPI slave in master out (direction controlled by eUSCI)	
P4.3/PM_UCA3CLK	P4.3/PM_UCA3CLK/S29	PM_UCA3CLK	eUSCI_A3 clock input/output (direction controlled by eUSCI)	

Table 6-12. Default Port Mapping (continued)

PIN NAME		PxMAPy MNEMONIC	INPUT PIN FUNCTION	OUTPUT PIN FUNCTION
PEU	PZ			
P4.4/PM_UCB1SOMI/ PM_UCB1SCL	P4.4/PM_UCB1SOMI/ PM_UCB1SCL/S28	PM_UCB1SOMI / PM_UCB1SCL	eUSCI_B1 SPI slave out master in (direction controlled by eUSCI), eUSCI_B1 I ² C clock (open drain and direction controlled by eUSCI)	
P4.5/PM_UCB1SIMO/ PM_UCB1SDA	P4.5/PM_UCB1SIMO/ PM_UCB1SDA/S27	PM_UCB1SIMO / PM_UCB1SDA	eUSCI_B1 SPI slave in master out (direction controlled by eUSCI), eUSCI_B1 I ² C data (open drain and direction controlled by eUSCI)	
P4.6/PM_UCB1CLK	P4.6/PM_UCB1CLK/S26	PM_UCB1CLK	eUSCI_B1 clock input/output (direction controlled by eUSCI)	
P4.7/PM_TA3.0	P4.7/PM_TA3.0/S25	PM_TA3.0	TA3 CCR0 capture input CCI0A	TA3 CCR0 compare output Out0

6.13.7 System Module (SYS) ([Link to User's Guide](#))

The SYS module handles many of the system functions within the device. These include power-on reset (POR) and power-up clear (PUC) handling, NMI source selection and management, reset interrupt vector generators, bootloader entry mechanisms, and configuration management (device descriptors). The SYS module also includes a data exchange mechanism using JTAG called a JTAG mailbox that can be used in the application. [Table 6-13](#) lists the SYS module interrupt vector registers.

Table 6-13. System Module Interrupt Vector Registers

INTERRUPT VECTOR REGISTER	ADDRESS	INTERRUPT EVENT	VALUE	PRIORITY
SYSRSTIV, System Reset	019Eh	No interrupt pending	00h	
		Brownout (BOR)	02h	Highest
		RST/NMI (POR)	04h	
		DoBOR (BOR)	06h	
		Wake up from LPMx.5	08h	
		Security violation (BOR)	0Ah	
		SVSL (POR)	0Ch	
		SVSH (POR)	0Eh	
		SVML_OVP (POR)	10h	
		SVMH_OVP (POR)	12h	
		DoPOR (POR)	14h	
		WDT time-out (PUC)	16h	
		WDT key violation (PUC)	18h	
		KEYV flash key violation (PUC)	1Ah	
		Reserved	1Ch	
		Peripheral area fetch (PUC)	1Eh	
		PMM key violation (PUC)	20h	
Reserved	22h to 3Eh	Lowest		
SYSSNIV, System NMI	019Ch	No interrupt pending	00h	
		SVMLIFG	02h	Highest
		SVMHIFG	04h	
		DLYLIFG	06h	
		DLYHIFG	08h	
		VMAIFG	0Ah	
		JMBINIFG	0Ch	
		JMBOUTIFG	0Eh	
		VLRIFG	10h	
		VLRHIFG	12h	
		Reserved	14h to 1Eh	Lowest

Table 6-13. System Module Interrupt Vector Registers (continued)

INTERRUPT VECTOR REGISTER	ADDRESS	INTERRUPT EVENT	VALUE	PRIORITY
SYSUNIV, User NMI	019Ah	No interrupt pending	00h	
		NMIIFG	02h	Highest
		OFIFG	04h	
		ACCVIFG	06h	
		AUXSWGIFG	08h	
		Reserved	0Ah to 1Eh	Lowest

6.13.8 Watchdog Timer (WDT_A) [\(Link to User's Guide\)](#)

The primary function of the WDT_A is to perform a controlled system restart after a software problem occurs. If the selected time interval expires, a system reset is generated. If the watchdog function is not needed in an application, the timer can be configured as an interval timer and can generate interrupts at selected time intervals.

6.13.9 DMA Controller [\(Link to User's Guide\)](#)

The DMA controller allows movement of data from one memory address to another without CPU intervention. For example, the DMA controller can move data from the ADC10_A conversion memory to RAM. Using the DMA controller can increase the throughput of peripheral modules. The DMA controller reduces system power consumption by allowing the CPU to remain in sleep mode, without having to awaken to move data to or from a peripheral. [Table 6-14](#) lists the triggers that can start a DMA transfer.

Table 6-14. DMA Trigger Assignments⁽¹⁾

TRIGGER	CHANNEL		
	0	1	2
0	DMAREQ	DMAREQ	DMAREQ
1	TA0CCR0 CCIFG	TA0CCR0 CCIFG	TA0CCR0 CCIFG
2	TA0CCR2 CCIFG	TA0CCR2 CCIFG	TA0CCR2 CCIFG
3	TA1CCR0 CCIFG	TA1CCR0 CCIFG	TA1CCR0 CCIFG
4	Reserved	Reserved	Reserved
5	TA2CCR0 CCIFG	TA2CCR0 CCIFG	TA2CCR0 CCIFG
6	Reserved	Reserved	Reserved
7	TA3CCR0 CCIFG	TA3CCR0 CCIFG	TA3CCR0 CCIFG
8	Reserved	Reserved	Reserved
9	Reserved	Reserved	Reserved
10	Reserved	Reserved	Reserved
11	Reserved	Reserved	Reserved
12	Reserved	Reserved	Reserved
13	SD24IFG	SD24IFG	SD24IFG
14	Reserved	Reserved	Reserved
15	Reserved	Reserved	Reserved
16	UCA0RXIFG	UCA0RXIFG	UCA0RXIFG
17	UCA0TXIFG	UCA0TXIFG	UCA0TXIFG
18	UCA1RXIFG	UCA1RXIFG	UCA1RXIFG
19	UCA1TXIFG	UCA1TXIFG	UCA1TXIFG
20	UCA2RXIFG	UCA2RXIFG	UCA2RXIFG
21	UCA2TXIFG	UCA2TXIFG	UCA2TXIFG

(1) Reserved DMA triggers may be used by other devices in the family. Reserved DMA triggers do not cause any DMA trigger event when selected.

Table 6-14. DMA Trigger Assignments⁽¹⁾ (continued)

TRIGGER	CHANNEL		
	0	1	2
22	UCB0RXIFG0	UCB0RXIFG0	UCB0RXIFG0
23	UCB0TXIFG0	UCB0TXIFG0	UCB0TXIFG0
24	ADC10IFG0	ADC10IFG0	ADC10IFG0
25	UCA3RXIFG	UCA3RXIFG	UCA3RXIFG
26	UCA3TXIFG	UCA3TXIFG	UCA3TXIFG
27	UCB1RXIFG0	UCB1RXIFG0	UCB1RXIFG0
28	UCB1TXIFG0	UCB1TXIFG0	UCB1TXIFG0
29	MPY ready	MPY ready	MPY ready
30	DMA2IFG	DMA0IFG	DMA1IFG
31	Reserved	Reserved	Reserved

6.13.10 CRC16 ([Link to User's Guide](#))

The CRC16 module produces a signature based on a sequence of entered data values and can be used for data checking purposes. The CRC16 module signature is based on the CRC-CCITT standard.

6.13.11 Hardware Multiplier ([Link to User's Guide](#))

The multiplication operation is supported by a dedicated peripheral module. The module performs operations with 32-, 24-, 16-, and 8-bit operands. The module supports signed and unsigned multiplication as well as signed and unsigned multiply-and-accumulate operations.

6.13.12 AES128 Accelerator ([Link to User's Guide](#))

The AES accelerator module performs encryption and decryption of 128-bit data with 128-bit keys according to the Advanced Encryption Standard (AES) (FIPS PUB 197) in hardware.

6.13.13 Enhanced Universal Serial Communication Interface (eUSCI) ([Links to User's Guide: UART Mode, SPI Mode, I²C Mode](#))

The eUSCI module is used for serial data communication. The eUSCI module supports synchronous communication protocols such as SPI (3- or 4-pin) and I²C, and asynchronous communication protocols such as UART, enhanced UART with automatic baud-rate detection, and IrDA.

The eUSCI_An module provides support for SPI (3- or 4-pin), UART, enhanced UART, and IrDA.

The eUSCI_Bn module provides support for SPI (3- or 4-pin) and I²C.

Four eUSCI_A and two eUSCI_B module are implemented in these devices.

6.13.14 ADC10_A ([Link to User's Guide](#))

The ADC10_A module supports fast 10-bit analog-to-digital conversions. The module implements a 10-bit SAR core, sample select control, reference generator, and a conversion results buffer. A window comparator with lower and upper limits allows CPU-independent result monitoring with three window comparator interrupt flags.

6.13.15 SD24_B ([Link to User's Guide](#))

The SD24_B module integrates up to seven independent 24-bit sigma-delta analog-to-digital converters. Each converter is designed with a fully differential analog input pair and programmable gain amplifier input stage. Also the converters are based on second-order oversampling sigma-delta modulators and digital decimation filters. The decimation filters are comb filters with selectable oversampling ratios of up to 1024.

6.13.16 TA0 [\(Link to User's Guide\)](#)

TA0 is a 16-bit timer/counter (Timer_A type) with three capture/compare registers. TA0 can support multiple capture/compares, PWM outputs, and interval timing (see [Table 6-15](#)). TA0 also has extensive interrupt capabilities. Interrupts may be generated from the counter on overflow conditions and from each of the capture/compare registers.

Table 6-15. TA0 Signal Connections

DEVICE INPUT SIGNAL	MODULE INPUT NAME	MODULE BLOCK	MODULE OUTPUT SIGNAL	DEVICE OUTPUT SIGNAL
PM_TACLK	TACLK	Timer	NA	NA
ACLK (internal)	ACLK			
SMCLK (internal)	SMCLK			
PM_TACLK	INCLK	CCR0	TA0	PM_TA0.0
PM_TA0.0	CCI0A			
CBOU (internal)	CCI0B			
DVSS	GND			
DVCC	VCC	CCR1	TA1	PM_TA0.1
PM_TA0.1	CCI1A			
ACLK (internal)	CCI1B			
DVSS	GND			
DVCC	VCC	CCR2	TA2	PM_TA0.2
PM_TA0.2	CCI2A			
DVSS	CCI2B			
DVSS	GND			
DVCC	VCC			

6.13.17 TA1 [\(Link to User's Guide\)](#)

TA1 is a 16-bit timer/counter (Timer_A type) with two capture/compare registers. TA1 can support multiple capture/compares, PWM outputs, and interval timing (see [Table 6-16](#)). TA1 also has extensive interrupt capabilities. Interrupts may be generated from the counter on overflow conditions and from each of the capture/compare registers.

Table 6-16. TA1 Signal Connections

DEVICE INPUT SIGNAL	MODULE INPUT NAME	MODULE BLOCK	MODULE OUTPUT SIGNAL	DEVICE OUTPUT SIGNAL
PM_TACLK	TACLK	Timer	NA	NA
ACLK (internal)	ACLK			
SMCLK (internal)	SMCLK			
PM_TACLK	INCLK	CCR0	TA0	PM_TA1.0
PM_TA1.0	CCI0A			
CBOU (internal)	CCI0B			
DVSS	GND			
DVCC	VCC	CCR1	TA1	PM_TA1.1
PM_TA1.1	CCI1A			
ACLK (internal)	CCI1B			
DVSS	GND			
DVCC	VCC			

6.13.18 TA2 [\(Link to User's Guide\)](#)

TA2 is a 16-bit timer/counter (Timer_A type) with two capture/compare registers. TA2 can support multiple capture/compares, PWM outputs, and interval timing (see [Table 6-17](#)). TA2 also has extensive interrupt capabilities. Interrupts may be generated from the counter on overflow conditions and from each of the capture/compare registers.

Table 6-17. TA2 Signal Connections

DEVICE INPUT SIGNAL	MODULE INPUT NAME	MODULE BLOCK	MODULE OUTPUT SIGNAL	DEVICE OUTPUT SIGNAL
PM_TACLK	TACLK	Timer	NA	NA
ACLK (internal)	ACLK			
SMCLK (internal)	SMCLK			
PM_TACLK	INCLK	CCR0	TA0	PM_TA2.0
PM_TA2.0	CCI0A			
CBOU (internal)	CCI0B			
DVSS	GND			
DVCC	VCC	CCR1	TA1	PM_TA2.1
PM_TA2.1	CCI1A			
ACLK (internal)	CCI1B			
DVSS	GND			
DVCC	VCC			SD24_B (internal) SD24CHx.SD24SCSx = 010b

6.13.19 TA3 [\(Link to User's Guide\)](#)

TA3 is a 16-bit timer/counter (Timer_A type) with two capture/compare registers. TA3 can support multiple capture/compares, PWM outputs, and interval timing (see [Table 6-18](#)). TA3 also has extensive interrupt capabilities. Interrupts may be generated from the counter on overflow conditions and from each of the capture/compare registers.

Table 6-18. TA3 Signal Connections

DEVICE INPUT SIGNAL	MODULE INPUT NAME	MODULE BLOCK	MODULE OUTPUT SIGNAL	DEVICE OUTPUT SIGNAL
PM_TACLK	TACLK	Timer	NA	
ACLK (internal)	ACLK			
SMCLK (internal)	SMCLK			
PM_TACLK	INCLK	CCR0	TA0	PM_TA3.0
PM_TA3.0	CCI0A			
CBOU (internal)	CCI0B			
DVSS	GND			
DVCC	VCC	CCR1	TA1	PM_TA3.1
PM_TA3.1	CCI1A			
ACLK (internal)	CCI1B			
DVSS	GND			
DVCC	VCC			SD24_B (internal) SD24CHx.SD24SCSx = 011b

6.13.20 SD24_B Triggers

Table 6-19 lists the input trigger connections to SD24_B converters from Timer_A modules and output trigger pulse connection from SD24_B to ADC10_A.

Table 6-19. SD24_B Input/Output Trigger Connections

DEVICE INPUT SIGNAL	MODULE INPUT SIGNAL	MODULE BLOCK	MODULE OUTPUT SIGNAL	DEVICE OUTPUT SIGNAL
TA0.1 (internal)	SD24_B SD24CHx.SD24SCSx = 001b	SD24_B	Trigger Pulse	ADC10_A (internal) ADC10SHSx = 011b
TA2.1 (internal)	SD24_B SD24CHx.SD24SCSx = 010b			
TA3.1 (internal)	SD24_B SD24CHx.SD24SCSx = 011b			

6.13.21 ADC10_A Triggers

Table 6-20 lists the input trigger connections to ADC10_A from Timer_A modules and SD24_B.

Table 6-20. ADC10_A Input Trigger Connections

DEVICE INPUT SIGNAL	MODULE INPUT SIGNAL	MODULE BLOCK
TA0.1 (internal)	ADC10_A ADC10SHSx = 001b	ADC10_A
TA3.0 (internal)	ADC10_A ADC10SHSx = 010b	
SD24_B trigger pulse (internal)	ADC10_A ADC10SHSx = 011b	

6.13.22 Real-Time Clock (RTC_C) ([Link to User's Guide](#))

The RTC_C module can be configured for real-time clock (RTC) and calendar mode providing seconds, hours, day of week, day of month, month, and year. The RTC_C control and configuration registers are password protected to ensure clock integrity against runaway code. Calendar mode integrates an internal calendar that compensates for months with less than 31 days and includes leap year correction. The RTC_C also supports flexible alarm functions, offset calibration, temperature compensation and time capture on two external events. The RTC_C on this device operates on dedicated AUXVCC3 supply and supports operation in LPM3.5.

6.13.23 Reference Module (REF) Voltage Reference ([Link to User's Guide](#))

The REF module generates all of the critical reference voltages that can be used by the various analog peripherals in the device. The analog peripherals include the ADC10_A, LCD_C, and SD24_B modules.

6.13.24 LCD_C ([Link to User's Guide](#))

The LCD_C driver generates the segment and common signals required to drive a liquid crystal display (LCD). The LCD_C controller has dedicated data memories to hold segment drive information. Common and segment signals are generated as defined by the mode. Static, 2-mux, 3-mux, 4-mux, up to 8-mux LCDs are supported. The module can provide a LCD voltage independent of the supply voltage with its integrated charge pump. It is possible to control the level of the LCD voltage and thus contrast by software. The module also provides an automatic blinking capability for individual segments in static, 2-mux, 3-mux, and 4-mux modes.

6.13.25 Comparator_B (Link to User's Guide)

The primary function of the Comparator_B module is to support precision slope analog-to-digital conversions, battery voltage supervision, and monitoring of external analog signals.

6.13.26 Embedded Emulation Module (EEM) (Link to User's Guide)

The EEM supports real-time in-system debugging. The L version of the EEM has the following features:

- Eight hardware triggers or breakpoints on memory access
- Two hardware triggers or breakpoints on CPU register write access
- Up to 10 hardware triggers that can be combined to form complex triggers or breakpoints
- Two cycle counters
- Sequencer
- State storage
- Clock control on module level

6.13.27 Peripheral File Map

Table 6-21 lists the base address and register offset addresses for all supported peripherals.

Table 6-21. Peripherals

MODULE NAME	BASE ADDRESS	OFFSET ADDRESS RANGE
Special Functions (see Table 6-22)	0100h	000h to 01Fh
PMM (see Table 6-23)	0120h	000h to 01Fh
Flash Control (see Table 6-24)	0140h	000h to 00Fh
CRC16 (see Table 6-25)	0150h	000h to 007h
RAM Control (see Table 6-26)	0158h	000h to 001h
Watchdog (see Table 6-27)	015Ch	000h to 001h
UCS (see Table 6-28)	0160h	000h to 01Fh
SYS (see Table 6-29)	0180h	000h to 01Fh
Shared Reference (see Table 6-30)	01B0h	000h to 001h
Port Mapping Control (see Table 6-31)	01C0h	000h to 007h
Port Mapping Port P2 (see Table 6-32)	01D0h	000h to 007h
Port Mapping Port P3 (see Table 6-33)	01D8h	000h to 007h
Port Mapping Port P4 (see Table 6-34)	01E0h	000h to 007h
Port P1, P2 (see Table 6-35)	0200h	000h to 01Fh
Port P3, P4 (see Table 6-36)	0220h	000h to 00Bh
Port P5, P6 (see Table 6-37)	0240h	000h to 00Bh
Port P7, P8 (see Table 6-38)	0260h	000h to 00Bh
Port P9, P10 (see Table 6-39) (Ports P9 and P10 not available in PZ package)	0280h	000h to 00Bh
Port P11 (see Table 6-40) (Port P11 not available in PZ package)	02A0h	000h to 00Bh
Port PJ (see Table 6-41)	0320h	000h to 01Fh
Timer TA0 (see Table 6-42)	0340h	000h to 03Fh
Timer TA1 (see Table 6-43)	0380h	000h to 03Fh
Timer TA2 (see Table 6-44)	0400h	000h to 03Fh
Timer TA3 (see Table 6-45)	0440h	000h to 03Fh
Backup Memory (see Table 6-46)	0480h	000h to 00Fh
32-Bit Hardware Multiplier (see Table 6-48)	04C0h	000h to 02Fh

Table 6-21. Peripherals (continued)

MODULE NAME	BASE ADDRESS	OFFSET ADDRESS RANGE
DMA General Control (see Table 6-49)	0500h	000h to 00Fh
DMA Channel 0 (see Table 6-50)	0500h	010h to 01Fh
DMA Channel 1 (see Table 6-51)	0500h	020h to 02Fh
DMA Channel 2 (see Table 6-52)	0500h	030h to 03Fh
RTC_C (see Table 6-47)	0C80h	000h to 03Fh
eUSCI_A0 (see Table 6-53)	05C0h	000h to 01Fh
eUSCI_A1 (see Table 6-54)	05E0h	000h to 01Fh
eUSCI_A2 (see Table 6-55)	0600h	000h to 01Fh
eUSCI_A3 (see Table 6-56)	0620h	000h to 01Fh
eUSCI_B0 (see Table 6-57)	0640h	000h to 02Fh
eUSCI_B1 (see Table 6-58)	0680h	000h to 02Fh
ADC10_A (see Table 6-59)	0740h	000h to 01Fh
SD24_B(see Table 6-60)	0800h	000h to 06Fh
Comparator_B (see Table 6-61)	08C0h	000h to 00Fh
AES Accelerator (see Table 6-62)	09C0h	000h to 00Fh
Auxiliary Supply (see Table 6-63)	09E0h	000h to 01Fh
LCD_C (see Table 6-64)	0A00h	000h to 05Fh

Table 6-22. Special Function Registers (Base Address: 0100h)

REGISTER DESCRIPTION	REGISTER	OFFSET
SFR interrupt enable	SFRIE1	00h
SFR interrupt flag	SFRIFG1	02h
SFR reset pin control	SFRRPCR	04h

Table 6-23. PMM Registers (Base Address: 0120h)

REGISTER DESCRIPTION	REGISTER	OFFSET
PMM control 0	PMMCTL0	00h
PMM control 1	PMMCTL1	02h
SVS high-side control	SVSMHCTL	04h
SVS low-side control	SVSMLCTL	06h
PMM interrupt flags	PMMIFG	0Ch
PMM interrupt enable	PMMIE	0Eh
PMM power mode 5 control register 0	PM5CTL0	10h

Table 6-24. Flash Control Registers (Base Address: 0140h)

REGISTER DESCRIPTION	REGISTER	OFFSET
Flash control 1	FCTL1	00h
Flash control 3	FCTL3	04h
Flash control 4	FCTL4	06h

Table 6-25. CRC16 Registers (Base Address: 0150h)

REGISTER DESCRIPTION	REGISTER	OFFSET
CRC data input	CRC16DI	00h
CRC result	CRCINIRES	04h

Table 6-26. RAM Control Registers (Base Address: 0158h)

REGISTER DESCRIPTION	REGISTER	OFFSET
RAM control 0	RCCTL0	00h

Table 6-27. Watchdog Registers (Base Address: 015Ch)

REGISTER DESCRIPTION	REGISTER	OFFSET
Watchdog timer control	WDTCTL	00h

Table 6-28. UCS Registers (Base Address: 0160h)

REGISTER DESCRIPTION	REGISTER	OFFSET
UCS control 0	UCSCTL0	00h
UCS control 1	UCSCTL1	02h
UCS control 2	UCSCTL2	04h
UCS control 3	UCSCTL3	06h
UCS control 4	UCSCTL4	08h
UCS control 5	UCSCTL5	0Ah
UCS control 6	UCSCTL6	0Ch
UCS control 7	UCSCTL7	0Eh
UCS control 8	UCSCTL8	10h

Table 6-29. SYS Registers (Base Address: 0180h)

REGISTER DESCRIPTION	REGISTER	OFFSET
System control	SYCTL	00h
Bootloader configuration area	SYBSLC	02h
JTAG mailbox control	SYJMBC	06h
JTAG mailbox input 0	SYJMBIO	08h
JTAG mailbox input 1	SYJMBI1	0Ah
JTAG mailbox output 0	SYJMBO0	0Ch
JTAG mailbox output 1	SYJMBO1	0Eh
Bus error vector generator	SYBERRIV	18h
User NMI vector generator	SYUNIV	1Ah
System NMI vector generator	SYSSNIV	1Ch
Reset vector generator	SYRSTIV	1Eh

Table 6-30. Shared Reference Registers (Base Address: 01B0h)

REGISTER DESCRIPTION	REGISTER	OFFSET
Shared reference control	REFCTL	00h

Table 6-31. Port Mapping Controller (Base Address: 01C0h)

REGISTER DESCRIPTION	REGISTER	OFFSET
Port mapping password	PMAPPWD	00h
Port mapping control	PMAPCTL	02h

Table 6-32. Port Mapping for Port P2 (Base Address: 01D0h)

REGISTER DESCRIPTION	REGISTER	OFFSET
Port P2.0 mapping	P2MAP0	00h
Port P2.1 mapping	P2MAP1	01h
Port P2.2 mapping	P2MAP2	02h
Port P2.3 mapping	P2MAP3	03h
Port P2.4 mapping	P2MAP4	04h
Port P2.5 mapping	P2MAP5	05h
Port P2.6 mapping	P2MAP6	06h
Port P2.7 mapping	P2MAP7	07h

Table 6-33. Port Mapping for Port P3 (Base Address: 01D8h)

REGISTER DESCRIPTION	REGISTER	OFFSET
Port P3.0 mapping	P3MAP0	00h
Port P3.1 mapping	P3MAP1	01h
Port P3.2 mapping	P3MAP2	02h
Port P3.3 mapping	P3MAP3	03h
Port P3.4 mapping	P3MAP4	04h
Port P3.5 mapping	P3MAP5	05h
Port P3.6 mapping	P3MAP6	06h
Port P3.7 mapping	P3MAP7	07h

Table 6-34. Port Mapping for Port P4 (Base Address: 01E0h)

REGISTER DESCRIPTION	REGISTER	OFFSET
Port P4.0 mapping	P4MAP0	00h
Port P4.1 mapping	P4MAP1	01h
Port P4.2 mapping	P4MAP2	02h
Port P4.3 mapping	P4MAP3	03h
Port P4.4 mapping	P4MAP4	04h
Port P4.5 mapping	P4MAP5	05h
Port P4.6 mapping	P4MAP6	06h
Port P4.7 mapping	P4MAP7	07h

Table 6-35. Port P1, P2 Registers (Base Address: 0200h)

REGISTER DESCRIPTION	REGISTER	OFFSET
Port P1 input	P1IN	00h
Port P1 output	P1OUT	02h
Port P1 direction	P1DIR	04h
Port P1 resistor enable	P1REN	06h
Port P1 drive strength	P1DS	08h
Port P1 selection 0	P1SEL0	0Ah
Port P1 selection 1	P1SEL1	0Ch
Port P1 interrupt vector word	P1IV	0Eh
Port P1 interrupt edge select	P1IES	18h
Port P1 interrupt enable	P1IE	1Ah
Port P1 interrupt flag	P1IFG	1Ch
Port P2 input	P2IN	01h
Port P2 output	P2OUT	03h
Port P2 direction	P2DIR	05h
Port P2 resistor enable	P2REN	07h
Port P2 drive strength	P2DS	09h
Port P2 selection 0	P2SEL0	0Bh
Port P2 selection 1 ⁽¹⁾	P2SEL1	0Dh
Port P2 interrupt vector word	P2IV	1Eh
Port P2 interrupt edge select	P2IES	19h
Port P2 interrupt enable	P2IE	1Bh
Port P2 interrupt flag	P2IFG	1Dh

(1) P2SEL1 is an empty control register to be consistent with P1SEL1 in 16-bit access.

Table 6-36. Port P3, P4 Registers (Base Address: 0220h)

REGISTER DESCRIPTION	REGISTER	OFFSET
Port P3 input	P3IN	00h
Port P3 output	P3OUT	02h
Port P3 direction	P3DIR	04h
Port P3 resistor enable	P3REN	06h
Port P3 drive strength	P3DS	08h
Port P3 selection 0	P3SEL0	0Ah
Port P4 input	P4IN	01h
Port P4 output	P4OUT	03h
Port P4 direction	P4DIR	05h
Port P4 resistor enable	P4REN	07h
Port P4 drive strength	P4DS	09h
Port P4 selection 0	P4SEL0	0Bh

Table 6-37. Port P5, P6 Registers (Base Address: 0240h)

REGISTER DESCRIPTION	REGISTER	OFFSET
Port P5 input	P5IN	00h
Port P5 output	P5OUT	02h
Port P5 direction	P5DIR	04h
Port P5 resistor enable	P5REN	06h
Port P5 drive strength	P5DS	08h
Port P5 selection 0	P5SEL0	0Ah
Port P5 selection 1	P5SEL1	0Ch
Port P6 input	P6IN	01h
Port P6 output	P6OUT	03h
Port P6 direction	P6DIR	05h
Port P6 resistor enable	P6REN	07h
Port P6 drive strength	P6DS	09h
Port P6 selection 0	P6SEL0	0Bh
Port P6 selection 1 ⁽¹⁾	P6SEL1	0Dh

(1) P6SEL1 is an empty control register to be consistent with P5SEL1 in 16-bit access.

Table 6-38. Port P7, P8 Registers (Base Address: 0260h)

REGISTER DESCRIPTION	REGISTER	OFFSET
Port P7 input	P7IN	00h
Port P7 output	P7OUT	02h
Port P7 direction	P7DIR	04h
Port P7 resistor enable	P7REN	06h
Port P7 drive strength	P7DS	08h
Port P7 selection 0	P7SEL0	0Ah
Port P8 input	P8IN	01h
Port P8 output	P8OUT	03h
Port P8 direction	P8DIR	05h
Port P8 resistor enable	P8REN	07h
Port P8 drive strength	P8DS	09h
Port P8 selection 0	P8SEL0	0Bh

Table 6-39. Port P9, P10 Registers (Base Address: 0280h)

REGISTER DESCRIPTION	REGISTER	OFFSET
Port P9 input	P9IN	00h
Port P9 output	P9OUT	02h
Port P9 direction	P9DIR	04h
Port P9 resistor enable	P9REN	06h
Port P9 drive strength	P9DS	08h
Port P9 selection 0	P9SEL0	0Ah
Port P10 input	P10IN	01h
Port P10 output	P10OUT	03h
Port P10 direction	P10DIR	05h
Port P10 resistor enable	P10REN	07h
Port P10 drive strength	P10DS	09h
Port P10 selection 0	P10SEL0	0Bh

Table 6-40. Port P11 Registers (Base Address: 02A0h)

REGISTER DESCRIPTION	REGISTER	OFFSET
Port P11 input	P11IN	00h
Port P11 output	P11OUT	02h
Port P11 direction	P11DIR	04h
Port P11 resistor enable	P11REN	06h
Port P11 drive strength	P11DS	08h
Port P11 selection 0	P11SEL0	0Ah

Table 6-41. Port J Registers (Base Address: 0320h)

REGISTER DESCRIPTION	REGISTER	OFFSET
Port PJ input	PJIN	00h
Port PJ output	PJOUT	02h
Port PJ direction	PJDIR	04h
Port PJ resistor enable	PJREN	06h
Port PJ drive strength	PJDS	08h
Port PJ selection	PJSEL	0Ah

Table 6-42. TA0 Registers (Base Address: 0340h)

REGISTER DESCRIPTION	REGISTER	OFFSET
TA0 control	TAOCTL	00h
Capture/compare control 0	TAOCTL0	02h
Capture/compare control 1	TAOCTL1	04h
Capture/compare control 2	TAOCTL2	06h
TA0 counter	TAOR	10h
Capture/compare 0	TAOCCR0	12h
Capture/compare 1	TAOCCR1	14h
Capture/compare 2	TAOCCR2	16h
TA0 expansion 0	TAOEX0	20h
TA0 interrupt vector	TAOIV	2Eh

Table 6-43. TA1 Registers (Base Address: 0380h)

REGISTER DESCRIPTION	REGISTER	OFFSET
TA1 control	TA1CTL	00h
Capture/compare control 0	TA1CCTL0	02h
Capture/compare control 1	TA1CCTL1	04h
TA1 counter	TA1R	10h
Capture/compare 0	TA1CCR0	12h
Capture/compare 1	TA1CCR1	14h
TA1 expansion 0	TA1EX0	20h
TA1 interrupt vector	TA1IV	2Eh

Table 6-44. TA2 Registers (Base Address: 0400h)

REGISTER DESCRIPTION	REGISTER	OFFSET
TA2 control	TA2CTL	00h
Capture/compare control 0	TA2CCTL0	02h
Capture/compare control 1	TA2CCTL1	04h
TA2 counter	TA2R	10h
Capture/compare 0	TA2CCR0	12h
Capture/compare 1	TA2CCR1	14h
TA2 expansion 0	TA2EX0	20h
TA2 interrupt vector	TA2IV	2Eh

Table 6-45. TA3 Registers (Base Address: 0440h)

REGISTER DESCRIPTION	REGISTER	OFFSET
TA3 control	TA3CTL	00h
Capture/compare control 0	TA3CCTL0	02h
Capture/compare control 1	TA3CCTL1	04h
TA3 counter	TA3R	10h
Capture/compare 0	TA3CCR0	12h
Capture/compare 1	TA3CCR1	14h
TA3 expansion 0	TA3EX0	20h
TA3 interrupt vector	TA3IV	2Eh

Table 6-46. Backup Memory Registers (Base Address: 0480h)

REGISTER DESCRIPTION	REGISTER	OFFSET
Backup memory 0	BAKMEM0	00h
Backup memory 1	BAKMEM1	02h
Backup memory 2	BAKMEM2	04h
Backup memory 3	BAKMEM3	06h

Table 6-47. RTC_C Registers (Base Address: 0C80h)

REGISTER DESCRIPTION	REGISTER	OFFSET
RTC control 0	RTCCTL0	00h
RTC password	RTCPWD	01h
RTC control 1	RTCCTL1	02h
RTC control 3	RTCCTL3	03h
RTC offset calibration	RTCOCAL	04h
RTC temperature compensation	RTCTCMP	06h
RTC prescaler 0 control	RTCP0CTL	08h
RTC prescaler 1 control	RTCP1CTL	0Ah
RTC prescaler 0	RTCP0	0Ch
RTC prescaler 1	RTCP1	0Dh
RTC interrupt vector word	RTCIV	0Eh
RTC seconds	RTCSEC	10h
RTC minutes	RTCMIN	11h
RTC hours	RTCHOUR	12h
RTC day of week	RTCDOW	13h
RTC days	RTCDAY	14h
RTC month	RTCMON	15h
RTC year	RTCYEAR	16h
RTC alarm minutes	RTCAMIN	18h
RTC alarm hours	RTCAHOUR	19h
RTC alarm day of week	RTCADOW	1Ah
RTC alarm days	RTCADAY	1Bh
Binary-to-BCD conversion	BIN2BCD	1Ch
BCD-to-Binary conversion	BCD2BIN	1Eh
Real-Time Clock Time Capture Control Register	RTCTCCTL	20h
Tamper Detect Pin 0 Control Register	RTCCAP0CTL	21h
Tamper Detect Pin 1 Control Register	RTCCAP1CTL	22h
RTC seconds Backup Register 0	RTCSECBK0	30h
RTC minutes Backup Register 0	RTCMINBK0	31h
RTC hours Backup Register 0	RTCHOURBK0	32h
RTC days Backup Register 0	RTCDAYBK0	33h
RTC month Backup Register 0	RTCMONBK0	34h
RTC year Backup Register 0	RTCYEARBK0	36h
RTC seconds Backup Register 1	RTCSECBK1	38h
RTC minutes Backup Register 1	RTCMINBK1	39h
RTC hours Backup Register 1	RTCHOURBK1	3Ah
RTC days Backup Register 1	RTCDAYBK1	3Bh
RTC month Backup Register 1	RTCMONBK1	3Ch
RTC year Backup Register 1	RTCYEARBK1	3Eh

Table 6-48. 32-Bit Hardware Multiplier Registers (Base Address: 04C0h)

REGISTER DESCRIPTION	REGISTER	OFFSET
16-bit operand 1 – multiply	MPY	00h
16-bit operand 1 – signed multiply	MPYS	02h
16-bit operand 1 – multiply accumulate	MAC	04h
16-bit operand 1 – signed multiply accumulate	MACS	06h
16-bit operand 2	OP2	08h
16 × 16 result low word	RESLO	0Ah
16 × 16 result high word	RESHI	0Ch
16 × 16 sum extension	SUMEXT	0Eh
32-bit operand 1 – multiply low word	MPY32L	10h
32-bit operand 1 – multiply high word	MPY32H	12h
32-bit operand 1 – signed multiply low word	MPYS32L	14h
32-bit operand 1 – signed multiply high word	MPYS32H	16h
32-bit operand 1 – multiply accumulate low word	MAC32L	18h
32-bit operand 1 – multiply accumulate high word	MAC32H	1Ah
32-bit operand 1 – signed multiply accumulate low word	MACS32L	1Ch
32-bit operand 1 – signed multiply accumulate high word	MACS32H	1Eh
32-bit operand 2 – low word	OP2L	20h
32-bit operand 2 – high word	OP2H	22h
32 × 32 result 0 – least significant word	RES0	24h
32 × 32 result 1	RES1	26h
32 × 32 result 2	RES2	28h
32 × 32 result 3 – most significant word	RES3	2Ah
MPY32 control 0	MPY32CTL0	2Ch

Table 6-49. DMA General Control Registers (Base Address: 0500h)

REGISTER DESCRIPTION	REGISTER	OFFSET
DMA module control 0	DMACTL0	00h
DMA module control 1	DMACTL1	02h
DMA module control 2	DMACTL2	04h
DMA module control 3	DMACTL3	06h
DMA module control 4	DMACTL4	08h
DMA interrupt vector	DMAIV	0Eh

Table 6-50. DMA Channel 0 Registers (Base Address: 0500h)

REGISTER DESCRIPTION	REGISTER	OFFSET
DMA channel 0 control	DMA0CTL	10h
DMA channel 0 source address low	DMA0SAL	12h
DMA channel 0 source address high	DMA0SAH	14h
DMA channel 0 destination address low	DMA0DAL	16h
DMA channel 0 destination address high	DMA0DAH	18h
DMA channel 0 transfer size	DMA0SZ	1Ah

Table 6-51. DMA Channel 1 Registers (Base Address: 0500h)

REGISTER DESCRIPTION	REGISTER	OFFSET
DMA channel 1 control	DMA1CTL	20h
DMA channel 1 source address low	DMA1SAL	22h
DMA channel 1 source address high	DMA1SAH	24h
DMA channel 1 destination address low	DMA1DAL	26h
DMA channel 1 destination address high	DMA1DAH	28h
DMA channel 1 transfer size	DMA1SZ	2Ah

Table 6-52. DMA Channel 2 Registers (Base Address: 0500h)

REGISTER DESCRIPTION	REGISTER	OFFSET
DMA channel 2 control	DMA2CTL	30h
DMA channel 2 source address low	DMA2SAL	32h
DMA channel 2 source address high	DMA2SAH	34h
DMA channel 2 destination address low	DMA2DAL	36h
DMA channel 2 destination address high	DMA2DAH	38h
DMA channel 2 transfer size	DMA2SZ	3Ah

Table 6-53. eUSCI_A0 Registers (Base Address: 05C0h)

REGISTER DESCRIPTION	REGISTER	OFFSET
USCI_A control word 0	UCA0CTLW0	00h
USCI_A control word 1	UCA0CTLW1	02h
USCI_A baud rate 0	UCA0BR0	06h
USCI_A baud rate 1	UCA0BR1	07h
USCI_A modulation control	UCA0MCTLW	08h
USCI_A status	UCA0STAT	0Ah
USCI_A receive buffer	UCA0RXBUF	0Ch
USCI_A transmit buffer	UCA0TXBUF	0Eh
USCI_A LIN control	UCA0ABCTL	10h
USCI_A IrDA transmit control	UCA0IRTCTL	12h
USCI_A IrDA receive control	UCA0IRRCTL	13h
USCI_A interrupt enable	UCA0IE	1Ah
USCI_A interrupt flags	UCA0IFG	1Ch
USCI_A interrupt vector word	UCA0IV	1Eh

Table 6-54. eUSCI_A1 Registers (Base Address:05E0h)

REGISTER DESCRIPTION	REGISTER	OFFSET
USCI_A control word 0	UCA1CTLW0	00h
USCI_A control word 1	UCA1CTLW1	02h
USCI_A baud rate 0	UCA1BR0	06h
USCI_A baud rate 1	UCA1BR1	07h
USCI_A modulation control	UCA1MCTLW	08h
USCI_A status	UCA1STAT	0Ah
USCI_A receive buffer	UCA1RXBUF	0Ch
USCI_A transmit buffer	UCA1TXBUF	0Eh
USCI_A LIN control	UCA1ABCTL	10h
USCI_A IrDA transmit control	UCA1IRTCTL	12h
USCI_A IrDA receive control	UCA1IRRCTL	13h
USCI_A interrupt enable	UCA1IE	1Ah
USCI_A interrupt flags	UCA1IFG	1Ch
USCI_A interrupt vector word	UCA1IV	1Eh

Table 6-55. eUSCI_A2 Registers (Base Address:0600h)

REGISTER DESCRIPTION	REGISTER	OFFSET
USCI_A control word 0	UCA2CTLW0	00h
USCI_A control word 1	UCA2CTLW1	02h
USCI_A baud rate 0	UCA2BR0	06h
USCI_A baud rate 1	UCA2BR1	07h
USCI_A modulation control	UCA2MCTLW	08h
USCI_A status	UCA2STAT	0Ah
USCI_A receive buffer	UCA2RXBUF	0Ch
USCI_A transmit buffer	UCA2TXBUF	0Eh
USCI_A LIN control	UCA2ABCTL	10h
USCI_A IrDA transmit control	UCA2IRTCTL	12h
USCI_A IrDA receive control	UCA2IRRCTL	13h
USCI_A interrupt enable	UCA2IE	1Ah
USCI_A interrupt flags	UCA2IFG	1Ch
USCI_A interrupt vector word	UCA2IV	1Eh

Table 6-56. eUSCI_A3 Registers (Base Address: 0620h)

REGISTER DESCRIPTION	REGISTER	OFFSET
USCI_A control word 0	UCA3CTLW0	00h
USCI_A control word 1	UCA3CTLW1	02h
USCI_A baud rate 0	UCA3BR0	06h
USCI_A baud rate 1	UCA3BR1	07h
USCI_A modulation control	UCA3MCTLW	08h
USCI_A status	UCA3STAT	0Ah
USCI_A receive buffer	UCA3RXBUF	0Ch
USCI_A transmit buffer	UCA3TXBUF	0Eh
USCI_A LIN control	UCA3ABCTL	10h
USCI_A IrDA transmit control	UCA3IRTCTL	12h
USCI_A IrDA receive control	UCA3IRRCTL	13h
USCI_A interrupt enable	UCA3IE	1Ah
USCI_A interrupt flags	UCA3IFG	1Ch
USCI_A interrupt vector word	UCA3IV	1Eh

Table 6-57. eUSCI_B0 Registers (Base Address: 0640h)

REGISTER DESCRIPTION	REGISTER	OFFSET
USCI_B control word 0	UCB0CTLW0	00h
USCI_B control word 1	UCB0CTLW1	02h
USCI_B bit rate 0	UCB0BR0	06h
USCI_B bit rate 1	UCB0BR1	07h
USCI_B status word	UCB0STATW	08h
USCI_B byte counter threshold	UCB0TBCNT	0Ah
USCI_B receive buffer	UCB0RXBUF	0Ch
USCI_B transmit buffer	UCB0TXBUF	0Eh
USCI_B I2C own address 0	UCB0I2COA0	14h
USCI_B I2C own address 1	UCB0I2COA1	16h
USCI_B I2C own address 2	UCB0I2COA2	18h
USCI_B I2C own address 3	UCB0I2COA3	1Ah
USCI_B received address	UCB0ADDRX	1Ch
USCI_B address mask	UCB0ADDMASK	1Eh
USCI I2C slave address	UCB0I2CSA	20h
USCI interrupt enable	UCB0IE	2Ah
USCI interrupt flags	UCB0IFG	2Ch
USCI interrupt vector word	UCB0IV	2Eh

Table 6-58. eUSCI_B1 Registers (Base Address: 0680h)

REGISTER DESCRIPTION	REGISTER	OFFSET
USCI_B control word 0	UCB1CTLW0	00h
USCI_B control word 1	UCB1CTLW1	02h
USCI_B bit rate 0	UCB1BR0	06h
USCI_B bit rate 1	UCB1BR1	07h
USCI_B status word	UCB1STATW	08h
USCI_B byte counter threshold	UCB1TBCNT	0Ah
USCI_B receive buffer	UCB1RXBUF	0Ch
USCI_B transmit buffer	UCB1TXBUF	0Eh
USCI_B I2C own address 0	UCB1I2COA0	14h
USCI_B I2C own address 1	UCB1I2COA1	16h
USCI_B I2C own address 2	UCB1I2COA2	18h
USCI_B I2C own address 3	UCB1I2COA3	1Ah
USCI_B received address	UCB1ADDRX	1Ch
USCI_B address mask	UCB1ADDMASK	1Eh
USCI I2C slave address	UCB1I2CSA	20h
USCI interrupt enable	UCB1IE	2Ah
USCI interrupt flags	UCB1IFG	2Ch
USCI interrupt vector word	UCB1IV	2Eh

Table 6-59. ADC10_A Registers (Base Address: 0740h)

REGISTER DESCRIPTION	REGISTER	OFFSET
ADC10_A control 0	ADC10CTL0	00h
ADC10_A control 1	ADC10CTL1	02h
ADC10_A control 2	ADC10CTL2	04h
ADC10_A window comparator low threshold	ADC10LO	06h
ADC10_A window comparator high threshold	ADC10HI	08h
ADC10_A memory control 0	ADC10MCTL0	0Ah
ADC10_A conversion memory	ADC10MCTL0	12h
ADC10_A interrupt enable	ADC10IE	1Ah
ADC10_A interrupt flags	ADC10IGH	1Ch
ADC10_A interrupt vector word	ADC10IV	1Eh

Table 6-60. SD24_B Registers (Base Address: 0800h)

REGISTER DESCRIPTION	REGISTER	OFFSET
SD24_B control 0	SD24BCTL0	00h
SD24_B control 1	SD24BCTL1	02h
SD24_B trigger control	SD24BTRGCTL	04h
SD24_B trigger OSR control	SD24BTRGOSR	06h
SD24_B trigger preload	SD24BTRGPRE	08h
SD24_B interrupt flag	SD24BIFG	0Ah
SD24_B interrupt enable	SD24BIE	0Ch
SD24_B interrupt vector	SD24BIV	0Eh
SD24_B converter 0 control	SD24BCCTL0	10h
SD24_B converter 0 input control	SD24BINCTL0	12h
SD24_B converter 0 OSR control	SD24BOSR0	14h
SD24_B converter 0 preload	SD24BPRE0	16h
SD24_B converter 1 control	SD24BCCTL1	18h
SD24_B converter 1 input control	SD24BINCTL1	1Ah
SD24_B converter 1 OSR control	SD24BOSR1	1Ch
SD24_B converter 1 preload	SD24BPRE1	1Eh
SD24_B converter 2 control	SD24BCCTL2	20h
SD24_B converter 2 input control	SD24BINCTL2	22h
SD24_B converter 2 OSR control	SD24BOSR2	24h
SD24_B converter 2 preload	SD24BPRE2	26h
SD24_B converter 3 control	SD24BCCTL3	28h
SD24_B converter 3 input control	SD24BINCTL3	2Ah
SD24_B converter 3 OSR control	SD24BOSR3	2Ch
SD24_B converter 3 preload	SD24BPRE3	2Eh
SD24_B converter 4 control	SD24BCCTL4	30h
SD24_B converter 4 input control	SD24BINCTL4	32h
SD24_B converter 4 OSR control	SD24BOSR4	34h
SD24_B converter 4 preload	SD24BPRE4	36h
SD24_B converter 5 control	SD24BCCTL5	38h
SD24_B converter 5 input control	SD24BINCTL5	3Ah
SD24_B converter 5 OSR control	SD24BOSR5	3Ch
SD24_B converter 5 preload	SD24BPRE5	3Eh
SD24_B converter 6 control	SD24BCCTL6	40h
SD24_B converter 6 input control	SD24BINCTL6	42h
SD24_B converter 6 OSR control	SD24BOSR6	44h
SD24_B converter 6 preload	SD24BPRE6	46h
SD24_B converter 0 conversion memory low word	SD24BMEML0	50h
SD24_B converter 0 conversion memory high word	SD24BMEMH0	52h
SD24_B converter 1 conversion memory low word	SD24BMEML1	54h
SD24_B converter 1 conversion memory high word	SD24BMEMH1	56h
SD24_B converter 2 conversion memory low word	SD24BMEML2	58h
SD24_B converter 2 conversion memory high word	SD24BMEMH2	5Ah
SD24_B converter 3 conversion memory low word	SD24BMEML3	5Ch
SD24_B converter 3 conversion memory high word	SD24BMEMH3	5Eh
SD24_B converter 4 conversion memory low word	SD24BMEML4	60h
SD24_B converter 4 conversion memory high word	SD24BMEMH4	62h
SD24_B converter 5 conversion memory low word	SD24BMEML5	64h

Table 6-60. SD24_B Registers (Base Address: 0800h) (continued)

REGISTER DESCRIPTION	REGISTER	OFFSET
SD24_B converter 5 conversion memory high word	SD24BMEMH5	66h
SD24_B converter 6 conversion memory low word	SD24BMEML6	68h
SD24_B converter 6 conversion memory high word	SD24BMEMH6	6Ah

Table 6-61. Comparator_B Register (Base Address: 08C0h)

REGISTER DESCRIPTION	REGISTER	OFFSET
Comp_B control 0	CBCTL0	00h
Comp_B control 1	CBCTL1	02h
Comp_B control 2	CBCTL2	04h
Comp_B control 3	CBCTL3	06h
Comp_B interrupt	CBINT	0Ch
Comp_B interrupt vector word	CBIV	0Eh

Table 6-62. AES Accelerator Registers (Base Address: 09C0h)

REGISTER DESCRIPTION	REGISTER	OFFSET
AES accelerator control 0	AESACTL0	00h
AES accelerator status	AESASTAT	04h
AES accelerator key	AESAKEY	06h
AES accelerator data in	AESADIN	08h
AES accelerator data out	AESADOUT	0Ah

Table 6-63. Auxiliary Supply Registers (Base Address: 09E0h)

REGISTER DESCRIPTION	REGISTER	OFFSET
Auxiliary supply control 0	AUXCTL0	00h
Auxiliary supply control 1	AUXCTL1	02h
Auxiliary supply control 2	AUXCTL2	04h
AUX2 charger control	AUX2CHCTL	12h
AUX3 charger control	AUX3CHCTL	14h
AUX ADC control	AUXADCCTL	16h
AUX interrupt flag	AUXIFG	1Ah
AUX interrupt enable	AUXIE	1Ch
AUX interrupt vector word	AUXIV	1Eh

Table 6-64. LCD_C Registers (Base Address: 0A00h)

REGISTER DESCRIPTION	REGISTER	OFFSET
LCD_C control 0	LCDCCTL0	000h
LCD_C control 1	LCDCCTL1	002h
LCD_C blinking control	LCDCBLKCTL	004h
LCD_C memory control	LCDCMEMCTL	006h
LCD_C voltage control	LCDCVCTL	008h
LCD_C port control 0	LCDCPCTL0	00Ah
LCD_C port control 1	LCDCPCTL1	00Ch
LCD_C port control 2	LCDCPCTL2	00Eh
LCD_C charge pump control	LCDCCPCTL	012h
LCD_C interrupt vector	LCDCIV	01Eh
Static and 2 to 4 mux modes		
LCD_C memory 1	LCDM1	020h
LCD_C memory 2	LCDM2	021h
⋮	⋮	⋮
LCD_C memory 20	LCDM20	033h
LCD_C blinking memory 1	LCDBM1	040h
LCD_C blinking memory 2	LCDBM2	041h
⋮	⋮	⋮
LCD_C blinking memory 20	LCDBM20	053h
5 to 8 mux modes		
LCD_C memory 1	LCDM1	020h
LCD_C memory 2	LCDM2	021h
⋮	⋮	⋮
LCD_C memory 40	LCDM40	047h

6.14 Input/Output Diagrams

6.14.1 Port P1 (P1.0 to P1.3) Input/Output With Schmitt Trigger (MSP430F677xIPEU Only)

Figure 6-6 shows the port diagram. Table 6-65 summarizes the selection of the pin functions.

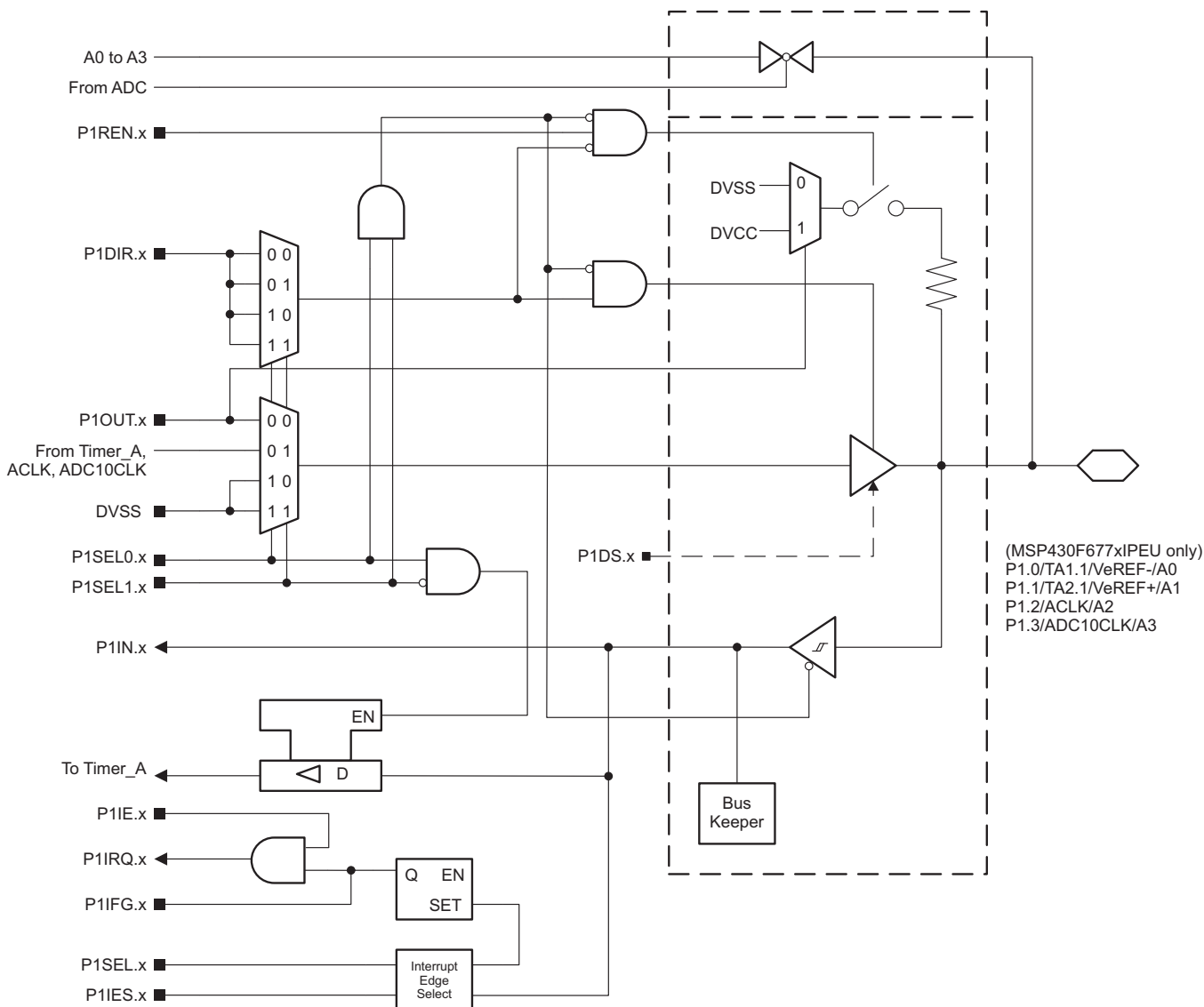

Figure 6-6. Port P1 (P1.0 to P1.3) Diagram (MSP430F677xIPEU Only)

Table 6-65. Port P1 (P1.0 to P1.3) Pin Functions (MSP430F677xIPEU Only)

PIN NAME (P1.x)	x	FUNCTION	CONTROL BITS OR SIGNALS ⁽¹⁾		
			P1DIR.x	P1SEL1.x	P1SEL0.x
P1.0/TA1.1/VeREF-/A0	0	P1.0 (I/O)	I:0; O:1	0	0
		TA1.CCI1A	0	0	1
		TA1.1	1	0	1
		N/A	0	1	0
		DVSS	1	1	0
		VeREF-/A0	X	1	1
P1.1/TA2.1/VeREF+/A1	1	P1.1 (I/O)	I:0; O:1	0	0
		TA2.CCI1A	0	0	1
		TA2.1	1	0	1
		N/A	0	1	0
		DVSS	1	1	0
		VeREF+/A1	X	1	1
P1.2/ACLK/A2	2	P1.2 (I/O)	I:0; O:1	0	0
		ACLK	1	0	1
		N/A	0	1	0
		DVSS	1	1	0
		A2	X	1	1
P1.3/ADC10CLK/A3	3	P1.3 (I/O)	I:0; O:1	0	0
		ADC10CLK	1	0	1
		N/A	0	1	0
		DVSS	1	1	0
		A3	X	1	1

(1) X = don't care

6.14.2 Port P1 (P1.0 to P1.3) Input/Output With Schmitt Trigger (MSP430F677xIPZ Only)

Figure 6-7 shows the port diagram. Table 6-66 summarizes the selection of the pin functions.

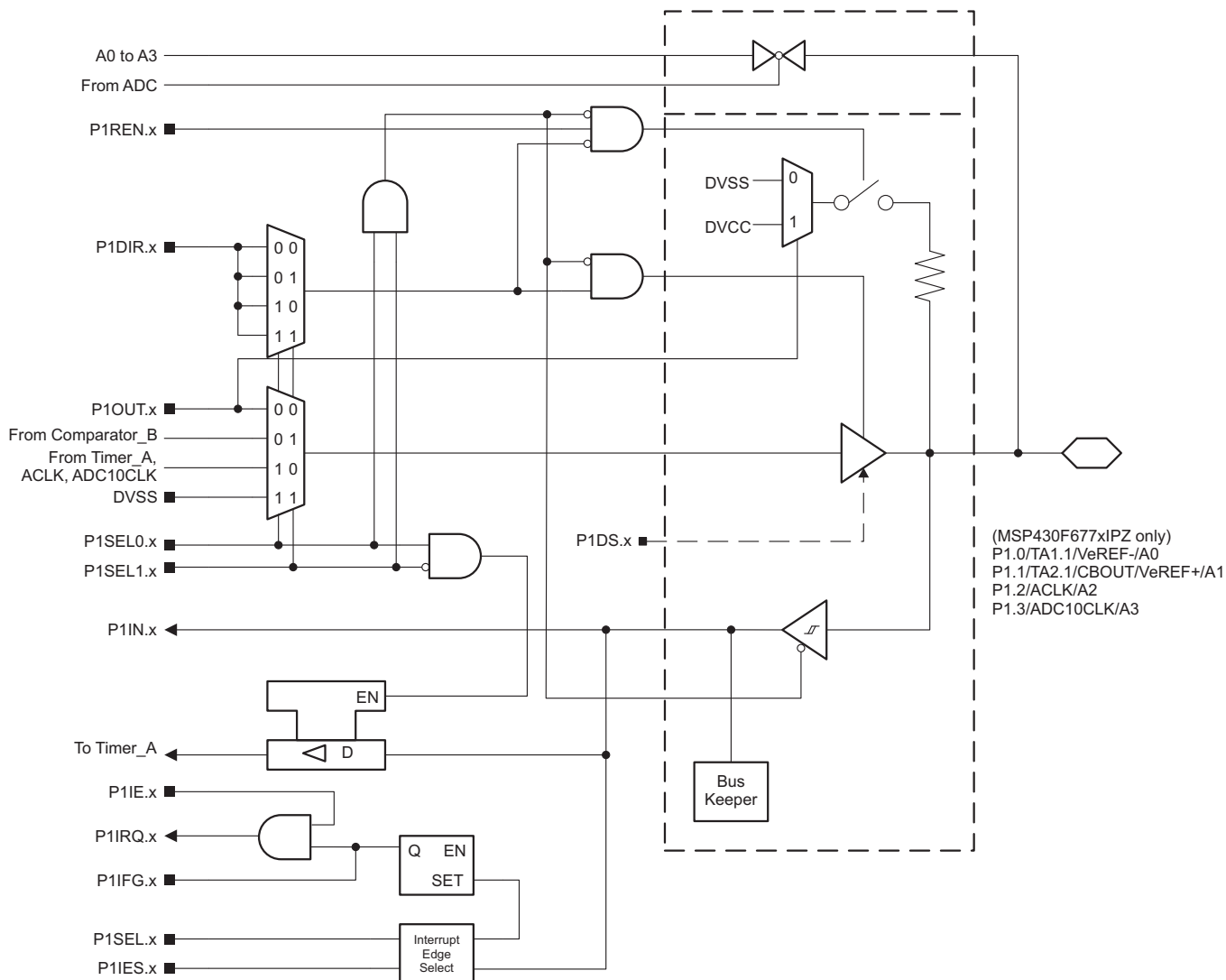

Figure 6-7. Port P1 (P1.0 to P1.3) Diagram (MSP430F677xIPZ Only)

Table 6-66. Port P1 (P1.0 to P1.3) Pin Functions (MSP430F677xIPZ Only)

PIN NAME (P1.x)	x	FUNCTION	CONTROL BITS OR SIGNALS ⁽¹⁾		
			P1DIR.x	P1SEL1.x	P1SEL0.x
P1.0/TA1.1/VeREF-/A0	0	P1.0 (I/O)	I:0; O:1	0	0
		TA1.CCI1A	0	0	1
		TA1.1	1	0	1
		N/A	0	1	0
		DVSS	1	1	0
		VeREF-/A0	X	1	1
P1.1/TA2.1/CBOUT/VeREF+/A1	1	P1.1 (I/O)	I:0; O:1	0	0
		TA2.CCI1A	0	0	1
		TA2.1	1	0	1
		N/A	0	1	0
		CBOUT	1	1	0
		VeREF+/A1	X	1	1
P1.2/ACLK/A2	2	P1.2 (I/O)	I:0; O:1	0	0
		ACLK	1	0	1
		N/A	0	1	0
		DVSS	1	1	0
		A2	X	1	1
P1.3/ADC10CLK/A3	3	P1.3 (I/O)	I:0; O:1	0	0
		ADC10CLK	1	0	1
		N/A	0	1	0
		DVSS	1	1	0
		A3	X	1	1

(1) X = don't care

6.14.3 Port P1 (P1.4 and P1.5) Input/Output With Schmitt Trigger (MSP430F677xIPEU and MSP430F677xIPZ)

Figure 6-8 shows the port diagram. Table 6-67 summarizes the selection of the pin functions.

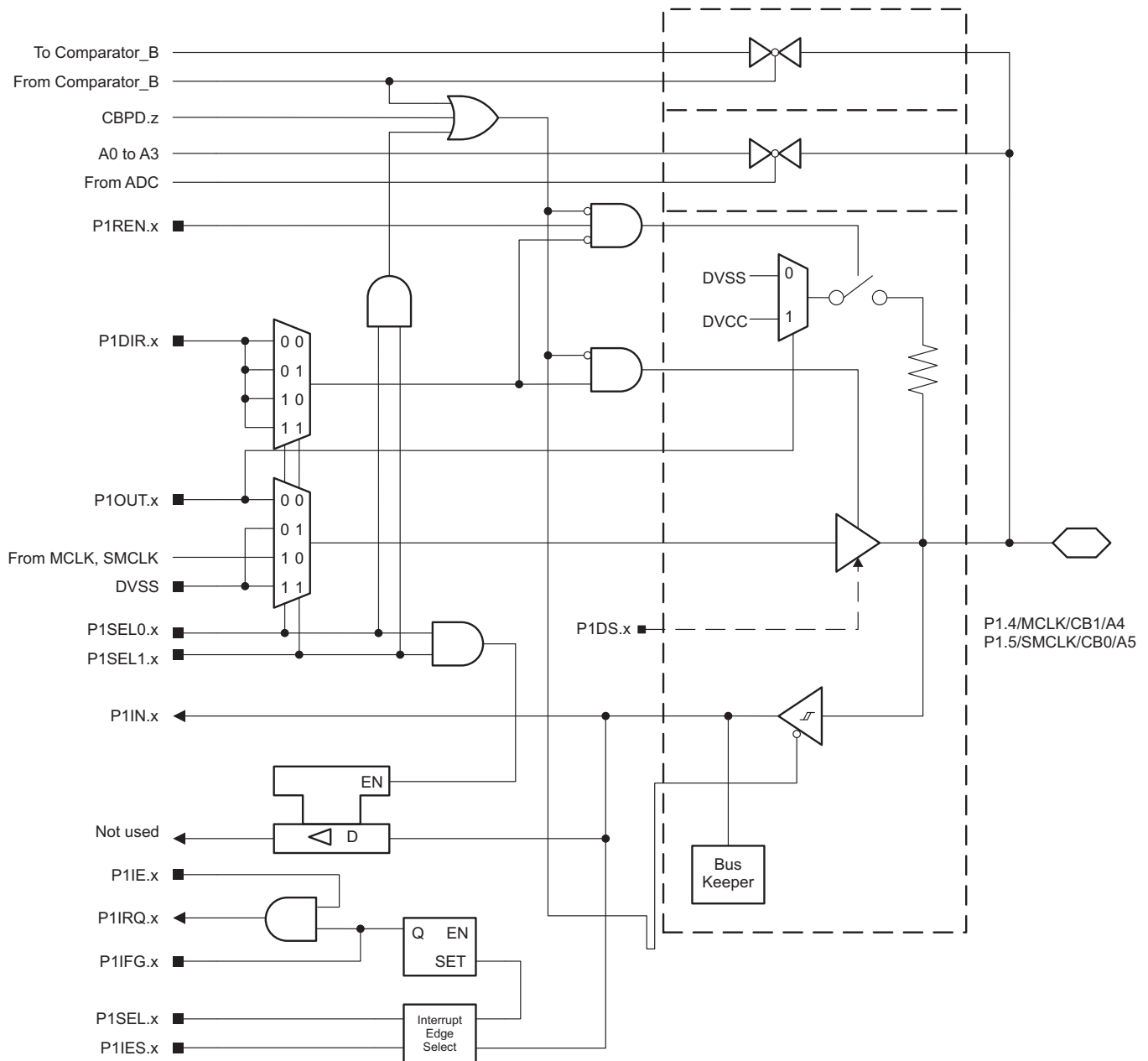

Figure 6-8. Port P1 (P1.4 and P1.5) Diagram (MSP430F677xIPEU and MSP430F677xIPZ)

Table 6-67. Port P1 (P1.4 and P1.5) Pin Functions (MSP430F677xIPEU and MSP430F677xIPZ)

PIN NAME (P1.x)	x	FUNCTION	CONTROL BITS OR SIGNALS ⁽¹⁾			
			P1DIR.x	P1SEL1.x	P1SEL0.x	CPBD.z
P1.4/MCLK/CB1/A4	4	P1.4 (I/O)	I:0; O:1	0	0	0
		MCLK	1	0	1	0
		N/A	0	1	0	0
		DVSS	1	1	0	0
		A4	X	1	1	0
		CB1	X	X	X	1 (z = 1)
P1.5/SMCLK/CB0/A5	5	P1.5 (I/O)	I:0; O:1	0	0	0
		SMCLK	1	0	1	0
		N/A	0	1	0	0
		DVSS	1	1	0	0
		A5	X	1	1	0
		CB0	X	X	X	1 (z = 0)

(1) X = don't care

6.14.4 Port P1 (P1.6 and P1.7) Input/Output With Schmitt Trigger (MSP430F677xIPEU and MSP430F677xIPZ)

Figure 6-9 shows the port diagram. Table 6-68 summarizes the selection of the pin functions.

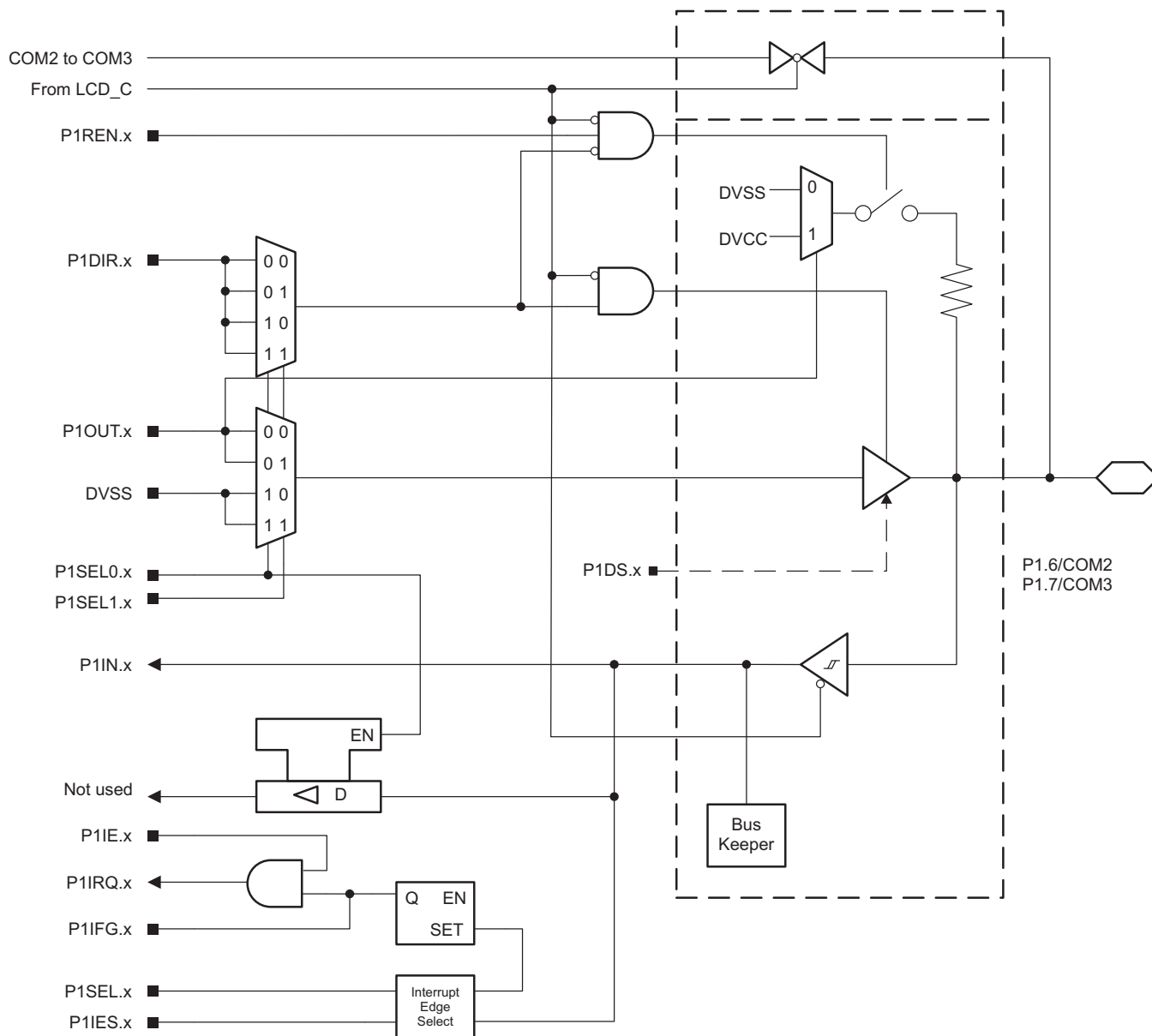

Figure 6-9. Port P1 (P1.6 and P1.7) Diagram (MSP430F677xIPEU and MSP430F677xIPZ)

Table 6-68. Port P1 (P1.6 and P1.7) Pin Functions (MSP430F677xIPEU and MSP430F677xIPZ)

PIN NAME (P1.x)	x	FUNCTION	CONTROL BITS OR SIGNALS ⁽¹⁾			
			P1DIR.x	P1SEL1.x	P1SEL0.x	COM Enable
P1.6/COM2	6	P1.6 (I/O)	I:0; O:1	X	0	0
		N/A	0	X	1	0
		DVSS	1	X	1	0
		COM2	X	X	X	1
P1.7/COM3	7	P1.7 (I/O)	I:0; O:1	X	0	0
		N/A	0	X	1	0
		DVSS	1	X	1	0
		COM3	X	X	X	1

(1) X = don't care

6.14.5 Port P2 (P2.0 to P2.7) Input/Output With Schmitt Trigger (MSP430F677xIPEU Only)

Figure 6-10 shows the port diagram. Table 6-69 summarizes the selection of the pin functions.

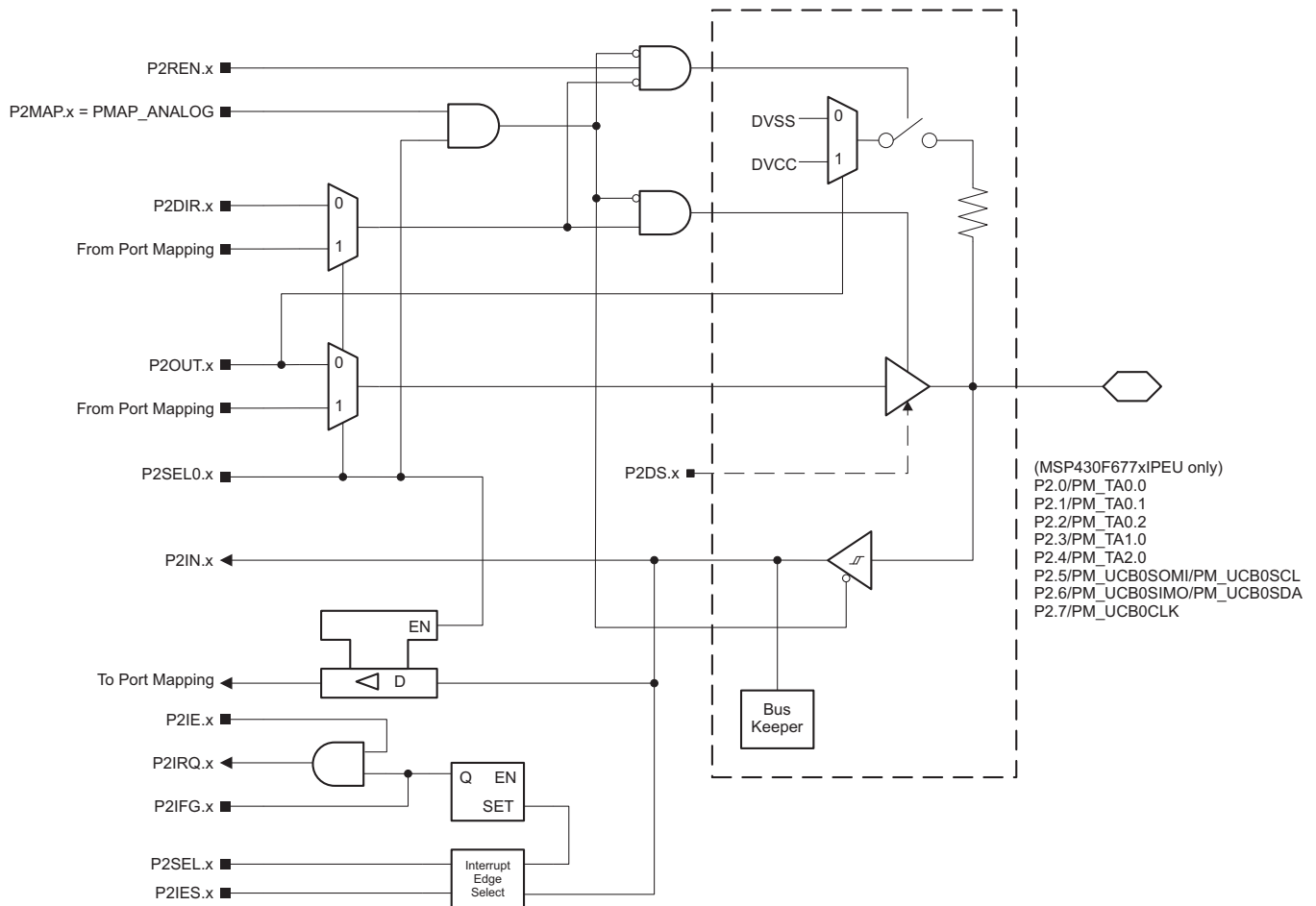

Figure 6-10. Port P2 (P2.0 to P2.7) Diagram (MSP430F677xIPEU Only)

Table 6-69. Port P2 (P2.0 to P2.7) Pin Functions (MSP430F677xIPEU Only)

PIN NAME (P2.x)	x	FUNCTION	CONTROL BITS OR SIGNALS ⁽¹⁾		
			P2DIR.x	P2SEL0.x	P2MAP.x
P2.0/PM_TA0.0	0	P2.0 (I/O)	I:0; O:1	0	X
		Mapped secondary digital function	X	1	≤ 30
		Output driver and input Schmitt trigger disabled	X	1	= 31
P2.1/PM_TA0.1	1	P2.1 (I/O)	I:0; O:1	0	X
		Mapped secondary digital function	X	1	≤ 30
		Output driver and input Schmitt trigger disabled	X	1	= 31
P2.2/PM_TA0.2	2	P2.2 (I/O)	I:0; O:1	0	X
		Mapped secondary digital function	X	1	≤ 30
		Output driver and input Schmitt trigger disabled	X	1	= 31
P2.3/PM_TA1.0	3	P2.3 (I/O)	I:0; O:1	0	X
		Mapped secondary digital function	X	1	≤ 30
		Output driver and input Schmitt trigger disabled	X	1	= 31
P2.4/PM_TA2.0	4	P2.4 (I/O)	I:0; O:1	0	X
		Mapped secondary digital function	X	1	≤ 30
		Output driver and input Schmitt trigger disabled	X	1	= 31
P2.5/PM_UCB0SOMI/ PM_UCB0SCL	5	P2.5 (I/O)	I:0; O:1	0	X
		Mapped secondary digital function	X	1	≤ 30
		Output driver and input Schmitt trigger disabled	X	1	= 31
P2.6/PM_UCB0SIMO/ PM_UCB0SDA	6	P2.6 (I/O)	I:0; O:1	0	X
		Mapped secondary digital function	X	1	≤ 30
		Output driver and input Schmitt trigger disabled	X	1	= 31
P2.7/PM_UCB0CLK	7	P2.7 (I/O)	I:0; O:1	0	X
		Mapped secondary digital function	X	1	≤ 30
		Output driver and input Schmitt trigger disabled	X	1	= 31

(1) X = don't care

6.14.6 Port P2 (P2.0 to P2.3) Input/Output With Schmitt Trigger (MSP430F677xIPZ Only)

Figure 6-11 shows the port diagram. Table 6-70 summarizes the selection of the pin functions.

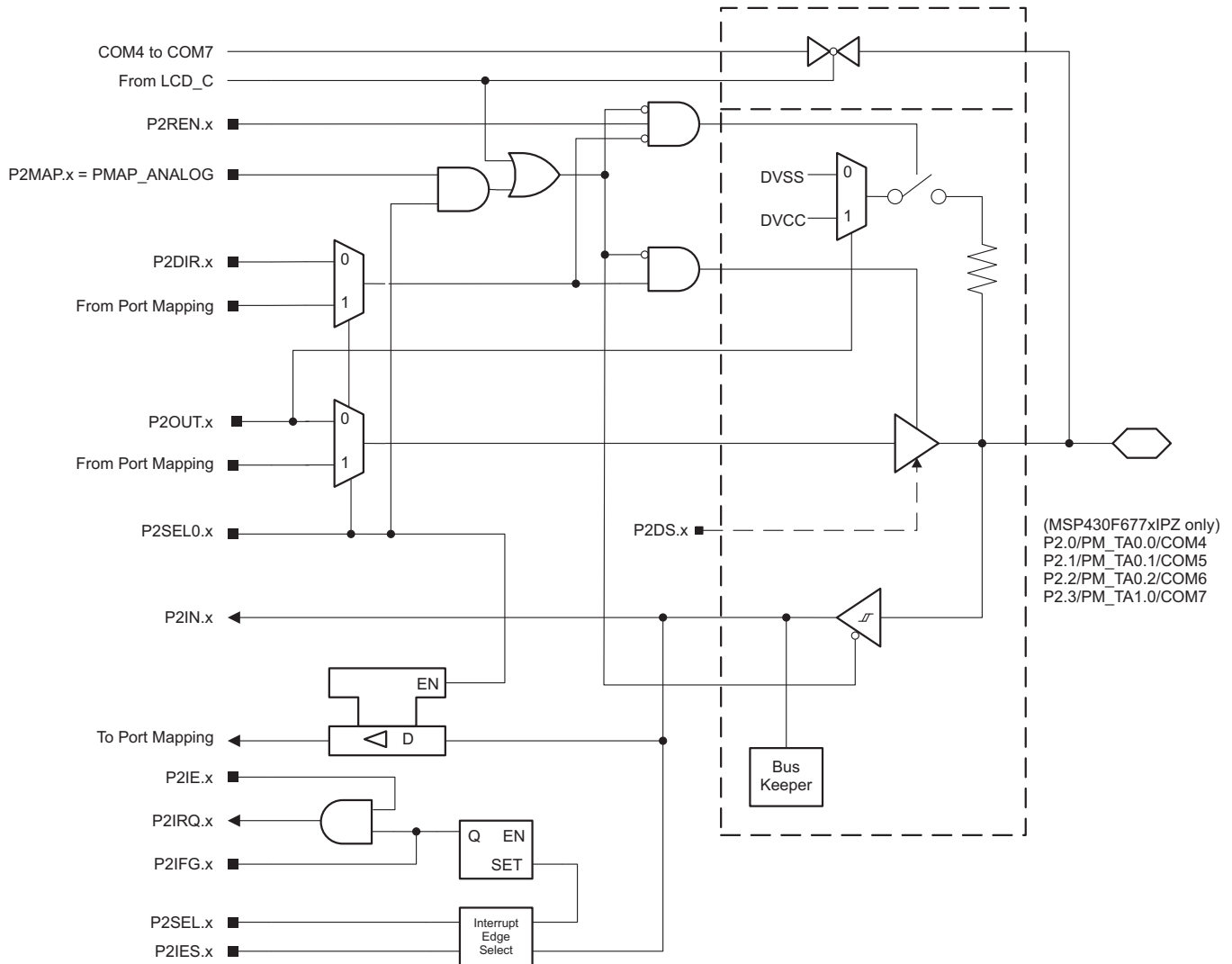

Figure 6-11. Port P2 (P2.0 to P2.3) Diagram (MSP430F677xIPZ Only)

Table 6-70. Port P2 (P2.0 to P2.3) Pin Functions (MSP430F677xIPZ Only)

PIN NAME (P2.x)	x	FUNCTION	CONTROL BITS OR SIGNALS ⁽¹⁾			
			P2DIR.x	P2SEL0.x	P2MAP.x	COM Enable
P2.0/PM_TA0.0/ COM4	0	P2.0 (I/O)	I:0; O:1	0	X	0
		Mapped secondary digital function	X	1	≤ 30	0
		Output driver and input Schmitt trigger disabled	X	1	= 31	0
		COM4	X	X	X	1
P2.1/PM_TA0.1/ COM5	1	P2.1 (I/O)	I:0; O:1	0	X	0
		Mapped secondary digital function	X	1	≤ 30	0
		Output driver and input Schmitt trigger disabled	X	1	= 31	0
		COM5	X	X	X	1
P2.2/PM_TA0.2/ COM6	2	P2.2 (I/O)	I:0; O:1	0	X	0
		Mapped secondary digital function	X	1	≤ 30	0
		Output driver and input Schmitt trigger disabled	X	1	= 31	0
		COM6	X	X	X	1
P2.3/PM_TA1.0/ COM7	3	P2.3 (I/O)	I:0; O:1	0	X	0
		Mapped secondary digital function	X	1	≤ 30	0
		Output driver and input Schmitt trigger disabled	X	1	= 31	0
		COM7	X	X	X	1

(1) X = don't care

6.14.7 Port P2 (P2.4 and P2.6) Input/Output With Schmitt Trigger (MSP430F677xIPZ Only)

Figure 6-12 shows the port diagram. Table 6-71 summarizes the selection of the pin functions.

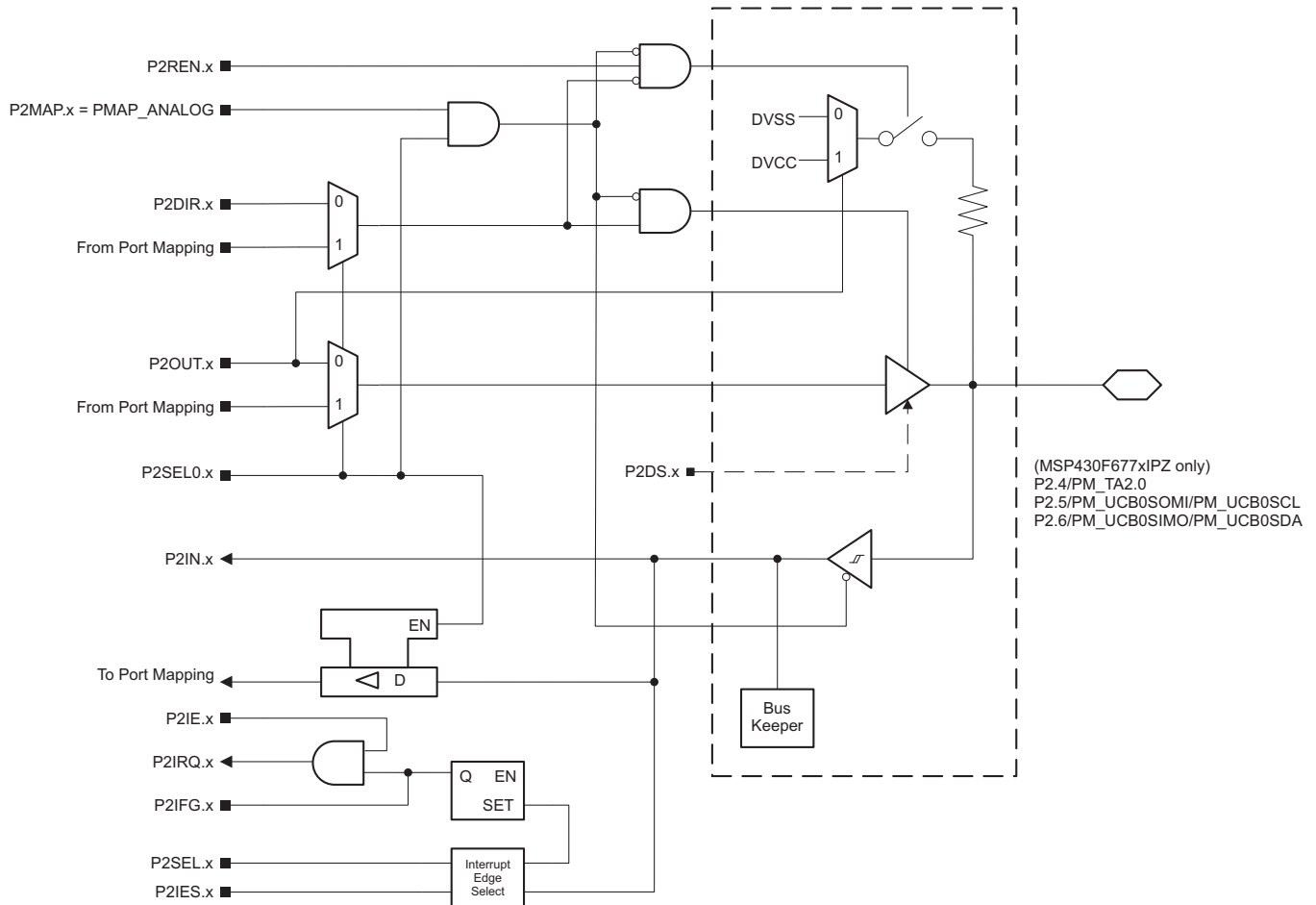

Figure 6-12. Port P2 (P2.4 and P2.6) Diagram (MSP430F677xIPZ Only)

Table 6-71. Port P2 (P2.4 and P2.6) Pin Functions (MSP430F677xIPZ Only)

PIN NAME (P2.x)	x	FUNCTION	CONTROL BITS OR SIGNALS ⁽¹⁾		
			P2DIR.x	P2SEL0.x	P2MAP.x
P2.4/PM_TA2.0/R23	4	P2.4 (I/O)	I:0; O:1	0	X
		Mapped secondary digital function	X	1	≤ 30
		R23	X	1	= 31
P2.5/PM_UCB0SOMI/ PM_UCB0SCL/R13	5	P2.5 (I/O)	I:0; O:1	0	X
		Mapped secondary digital function	X	1	≤ 30
		R13	X	1	= 31
P2.6/PM_UCB0SIMO/ PM_UCB0SDA/R03	6	P2.6 (I/O)	I:0; O:1	0	X
		Mapped secondary digital function	X	1	≤ 30
		R03	X	1	= 31

(1) X = don't care

6.14.8 Port P2 (P2.7) Input/Output With Schmitt Trigger (MSP430F677xIPZ Only)

Figure 6-13 shows the port diagram. Table 6-72 summarizes the selection of the pin functions.

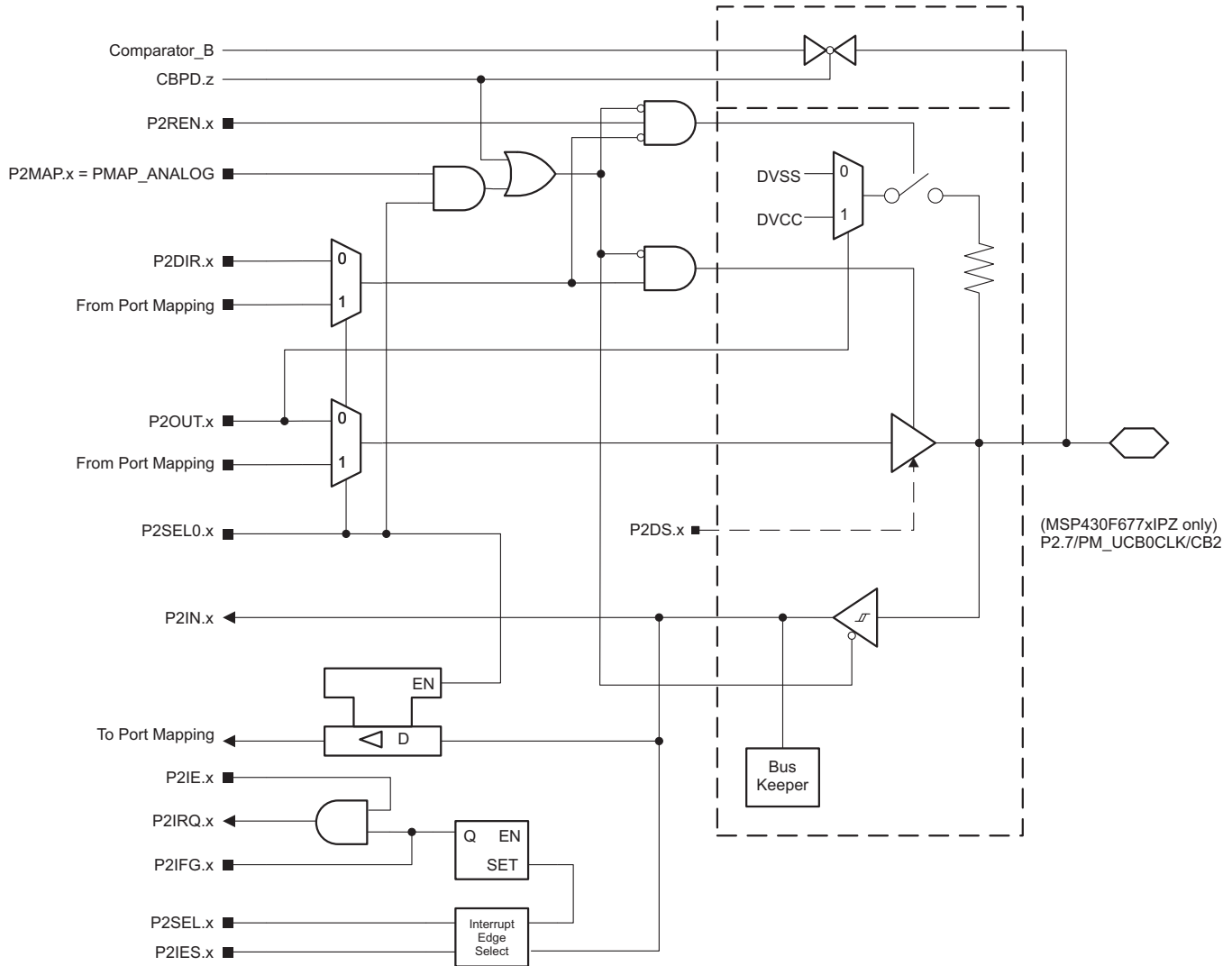

Figure 6-13. Port P2 (P2.7) Diagram (MSP430F677xIPZ Only)

Table 6-72. Port P2 (P2.7) Pin Functions (MSP430F677xIPZ Only)

PIN NAME (P2.x)	x	FUNCTION	CONTROL BITS OR SIGNALS ⁽¹⁾			
			P2DIR.x	P2SEL0.x	P2MAP.x	CBPD.z
P2.7/PM_UCB0CLK/ CB2	7	P2.7 (I/O)	I:0; O:1	0	X	0
		Mapped secondary digital function	X	1	≤ 30	0
		Output driver and input Schmitt trigger disabled	X	1	= 31	0
		CB2	X	X	X	1 (z = 2)

(1) X = don't care

6.14.9 Ports P3 (P3.0 to P3.7) Input/Output With Schmitt Trigger (MSP430F677xIPEU Only)

Figure 6-14 shows the port diagram. Table 6-73 summarizes the selection of the pin functions.

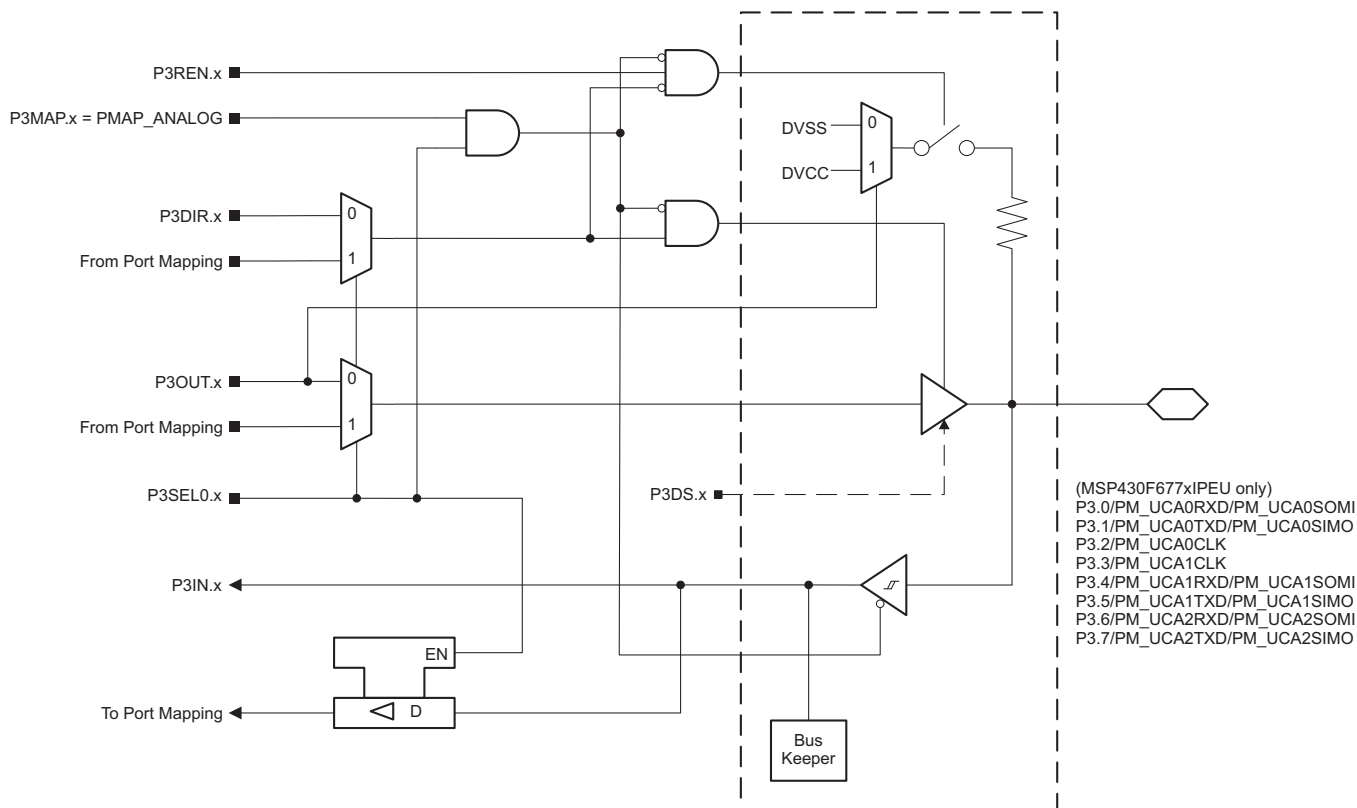

Figure 6-14. Ports P3 (P3.0 to P3.7) Diagram (MSP430F677xIPEU Only)

Table 6-73. Ports P3 (P3.0 to P3.7) Pin Functions (MSP430F677xIPEU Only)

PIN NAME (P3.x)	x	FUNCTION	CONTROL BITS OR SIGNALS ⁽¹⁾		
			P3DIR.x	P3SEL0.x	P3MAP.x
P3.0/PM_UCA0RXD/ PM_UCA0SOMI	0	P3.0 (I/O)	I:0; O:1	0	X
		Mapped secondary digital function	X	1	≤ 30
		Output driver and input Schmitt trigger disabled	X	1	= 31
P3.1/PM_UCA0TXD/ PM_UCA0SIMO	1	P3.1 (I/O)	I:0; O:1	0	X
		Mapped secondary digital function	X	1	≤ 30
		Output driver and input Schmitt trigger disabled	X	1	= 31
P3.2/PM_UCA0CLK	2	P3.2 (I/O)	I:0; O:1	0	X
		Mapped secondary digital function	X	1	≤ 30
		Output driver and input Schmitt trigger disabled	X	1	= 31
P3.3/PM_UCA1CLK	3	P3.3 (I/O)	I:0; O:1	0	X
		Mapped secondary digital function	X	1	≤ 30
		Output driver and input Schmitt trigger disabled	X	1	= 31
P3.4/PM_UCA1RXD/ PM_UCA1SOMI	4	P3.4 (I/O)	I:0; O:1	0	X
		Mapped secondary digital function	X	1	≤ 30
		Output driver and input Schmitt trigger disabled	X	1	= 31
P3.5/PM_UCA1TXD/ PM_UCA1SIMO	5	P3.5 (I/O)	I:0; O:1	0	X
		Mapped secondary digital function	X	1	≤ 30
		Output driver and input Schmitt trigger disabled	X	1	= 31
P3.6/PM_UCA2RXD/ PM_UCA2SOMI	6	P3.6 (I/O)	I:0; O:1	0	X
		Mapped secondary digital function	X	1	≤ 30
		Output driver and input Schmitt trigger disabled	X	1	= 31
P3.7/PM_UCA2TXD/ PM_UCA2SIMO	7	P3.7 (I/O)	I:0; O:1	0	X
		Mapped secondary digital function	X	1	≤ 30
		Output driver and input Schmitt trigger disabled	X	1	= 31

(1) X = don't care

6.14.10 Ports P3 (P3.0) Input/Output With Schmitt Trigger (MSP430F677xIPZ Only)

Figure 6-15 shows the port diagram. Table 6-74 summarizes the selection of the pin functions.

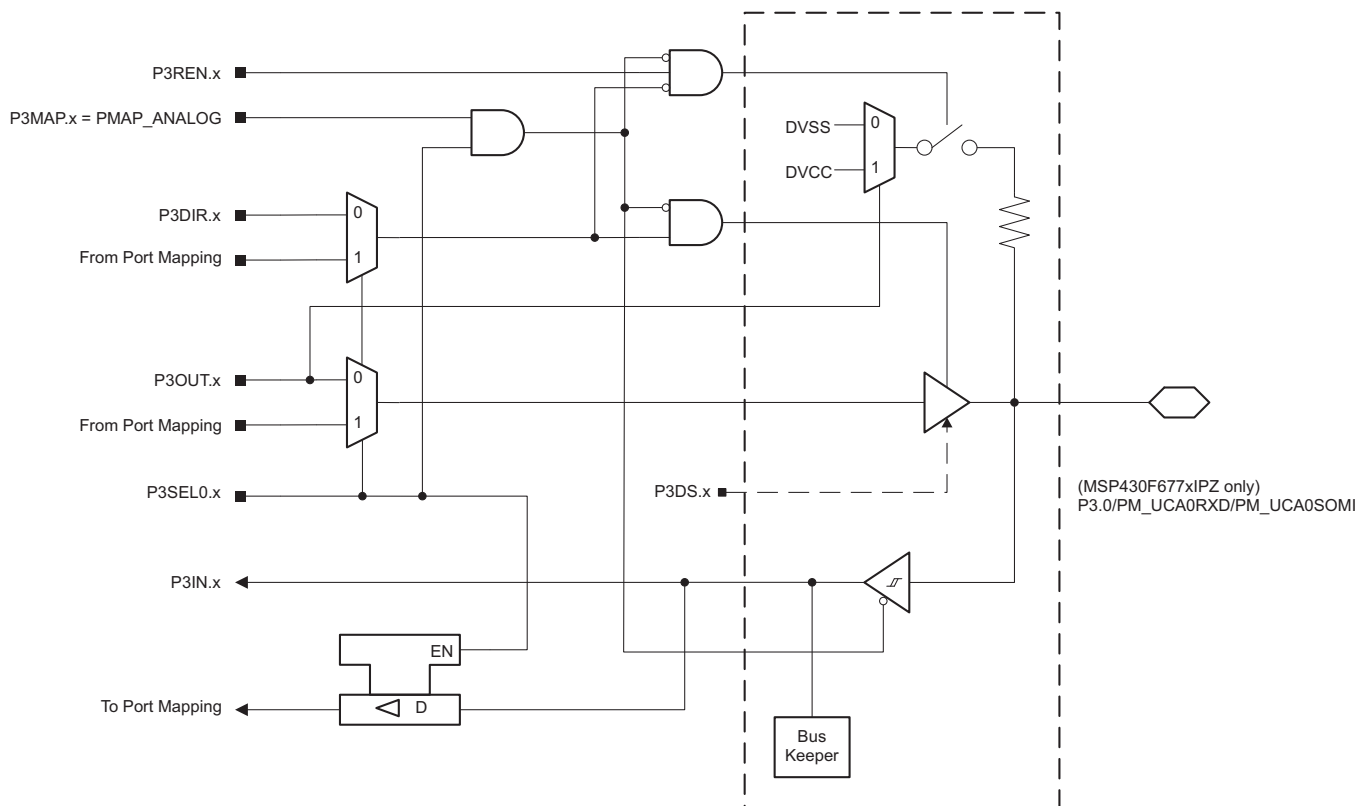

Figure 6-15. Ports P3 (P3.0) Diagram (MSP430F677xIPZ Only)

Table 6-74. Ports P3 (P3.0) Pin Functions (MSP430F677xIPZ Only)

PIN NAME (P3.x)	x	FUNCTION	CONTROL BITS OR SIGNALS ⁽¹⁾		
			P3DIR.x	P3SEL0.x	P3MAP.x
P3.0/PM_UCA0RXD/ PM_UCA0SOMI	0	P3.0 (I/O)	I:0; O:1	0	X
		Mapped secondary digital function	X	1	≤ 30
		Output driver and input Schmitt trigger disabled	X	1	= 31

(1) X = don't care

6.14.11 Ports P3 (P3.1 to P3.7) Input/Output With Schmitt Trigger (MSP430F677xIPZ Only)

Figure 6-16 shows the port diagram. Table 6-75 summarizes the selection of the pin functions.

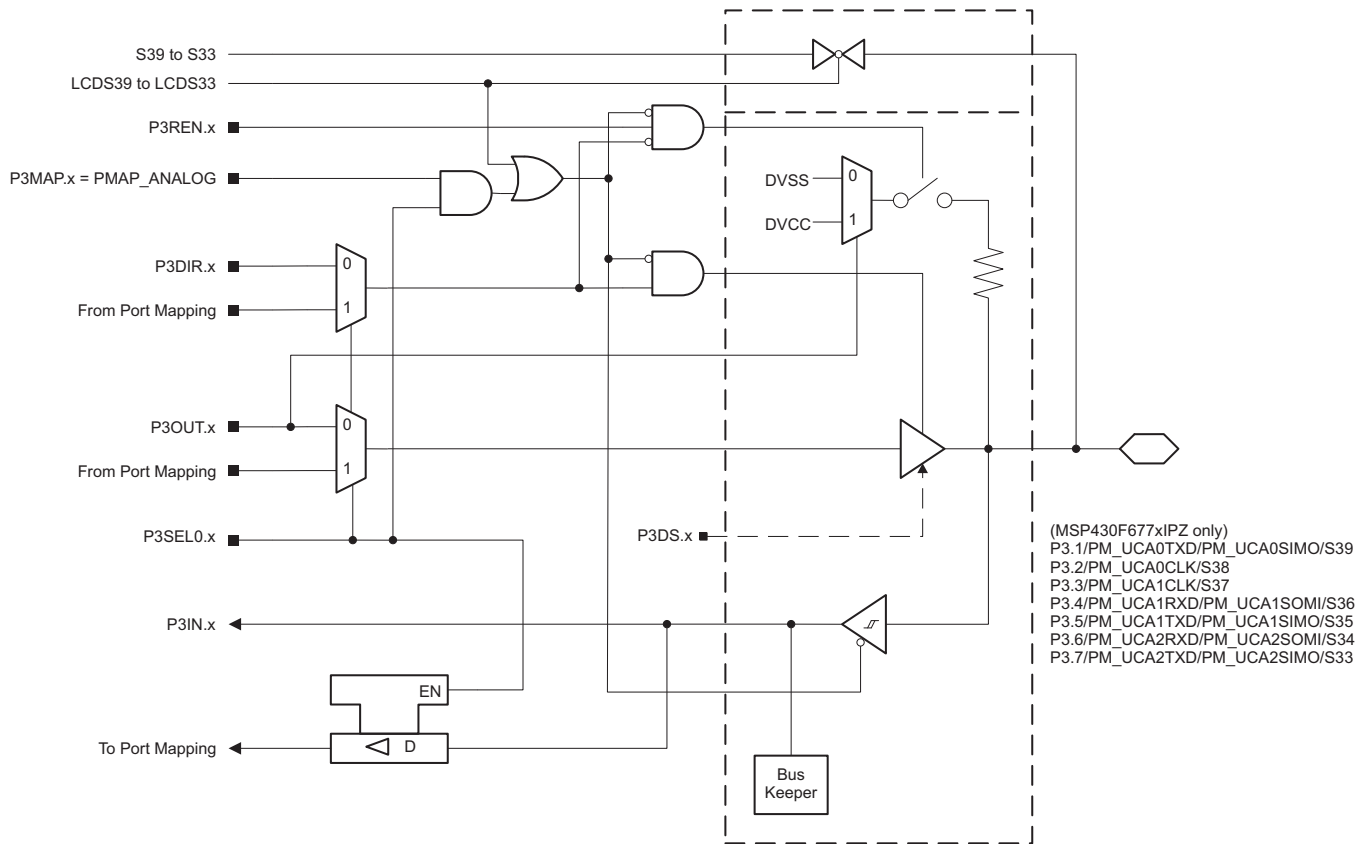

Figure 6-16. Ports P3 (P3.1 to P3.7) Diagram (MSP430F677xIPZ Only)

Table 6-75. Ports P3 (P3.1 to P3.7) Pin Functions (MSP430F677xIPZ Only)

PIN NAME (P3.x)	x	FUNCTION	CONTROL BITS OR SIGNALS ⁽¹⁾			
			P3DIR.x	P3SEL0.x	P3MAP.x	LCD39 to LCD33
P3.1/PM_UCA0TXD/ PM_UCA0SIMO/S39	1	P3.1 (I/O)	I:0; O:1	0	X	0
		Mapped secondary digital function	X	1	≤ 30	0
		Output driver and input Schmitt trigger disabled	X	1	= 31	0
		S39	X	X	X	1
P3.2/PM_UCA0CLK/ S38	2	P3.2 (I/O)	I:0; O:1	0	X	0
		Mapped secondary digital function	X	1	≤ 30	0
		Output driver and input Schmitt trigger disabled	X	1	= 31	0
		S38	X	X	X	1
P3.3/PM_UCA1CLK/ S37	3	P3.3 (I/O)	I:0; O:1	0	X	0
		Mapped secondary digital function	X	1	≤ 30	0
		Output driver and input Schmitt trigger disabled	X	1	= 31	0
		S37	X	X	X	1
P3.4/PM_UCA1RXD/ PM_UCA1SOMI/S36	4	P3.4 (I/O)	I:0; O:1	0	X	0
		Mapped secondary digital function	X	1	≤ 30	0
		Output driver and input Schmitt trigger disabled	X	1	= 31	0
		S36	X	X	X	1
P3.5/PM_UCA1TXD/ PM_UCA1SIMO/S35	5	P3.5 (I/O)	I:0; O:1	0	X	0
		Mapped secondary digital function	X	1	≤ 30	0
		Output driver and input Schmitt trigger disabled	X	1	= 31	0
		S35	X	X	X	1
P3.6/PM_UCA2RXD/ PM_UCA2SOMI/S34	6	P3.6 (I/O)	I:0; O:1	0	X	0
		Mapped secondary digital function	X	1	≤ 30	0
		Output driver and input Schmitt trigger disabled	X	1	= 31	0
		S34	X	X	X	1
P3.7/PM_UCA2TXD/ PM_UCA2SIMO/S33	7	P3.7 (I/O)	I:0; O:1	0	X	0
		Mapped secondary digital function	X	1	≤ 30	0
		Output driver and input Schmitt trigger disabled	X	1	= 31	0
		S33	X	X	X	1

(1) X = don't care

6.14.12 Port P4 (P4.0 to P4.7) Input/Output With Schmitt Trigger (MSP430F677xIPEU Only)

Figure 6-17 shows the port diagram. Table 6-76 summarizes the selection of the pin functions.

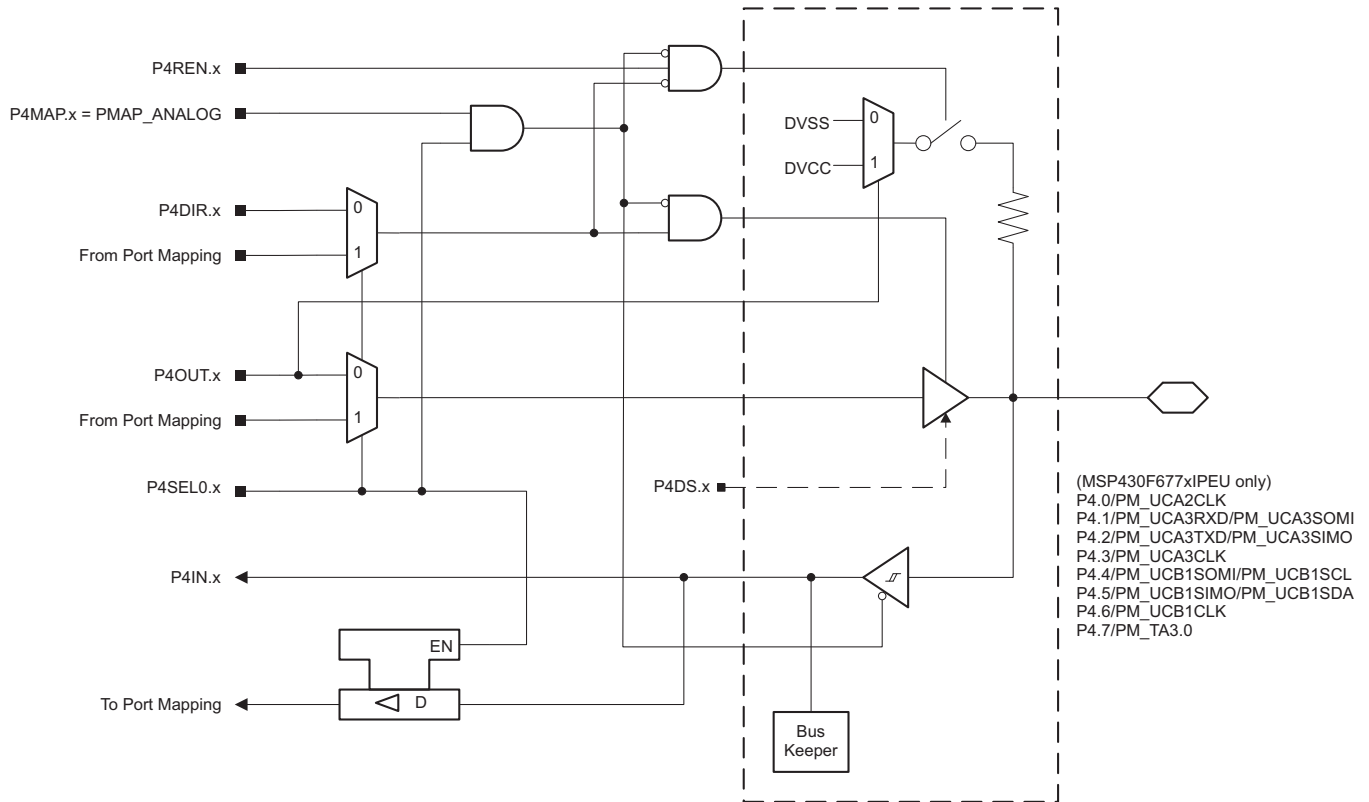

Figure 6-17. Port P4 (P4.0 to P4.7) Diagram (MSP430F677xIPEU Only)

Table 6-76. Port P4 (P4.0 to P4.7) Pin Functions (MSP430F677xIPEU Only)

PIN NAME (P4.x)	x	FUNCTION	CONTROL BITS OR SIGNALS ⁽¹⁾		
			P4DIR.x	P4SEL0.x	P4MAP.x
P4.0/PM_UCA2CLK	0	P4.0 (I/O)	I:0; O:1	0	X
		Mapped secondary digital function	X	1	≤ 30
		Output driver and input Schmitt trigger disabled	X	1	= 31
P4.1/PM_UCA3RXD/ PM_UCA3SOMI	1	P4.1 (I/O)	I:0; O:1	0	X
		Mapped secondary digital function	X	1	≤ 30
		Output driver and input Schmitt trigger disabled	X	1	= 31
P4.2/PM_UCA3TXD/ PM_UCA3SIMO	2	P4.2 (I/O)	I:0; O:1	0	X
		Mapped secondary digital function	X	1	≤ 30
		Output driver and input Schmitt trigger disabled	X	1	= 31
P4.3/PM_UCA3CLK	3	P4.3 (I/O)	I:0; O:1	0	X
		Mapped secondary digital function	X	1	≤ 30
		Output driver and input Schmitt trigger disabled	X	1	= 31
P4.4/PM_UCB1SOMI/ PM_UCB1SCL	4	P4.4 (I/O)	I:0; O:1	0	X
		Mapped secondary digital function	X	1	≤ 30
		Output driver and input Schmitt trigger disabled	X	1	= 31
P4.5/PM_UCB1SIMO/ PM_UCB1SDA	5	P4.5 (I/O)	I:0; O:1	0	X
		Mapped secondary digital function	X	1	≤ 30
		Output driver and input Schmitt trigger disabled	X	1	= 31
P4.6/PM_UCB1CLK	6	P4.6 (I/O)	I:0; O:1	0	X
		Mapped secondary digital function	X	1	≤ 30
		Output driver and input Schmitt trigger disabled	X	1	= 31
P4.7/PM_TA3.0	7	P4.7 (I/O)	I:0; O:1	0	X
		Mapped secondary digital function	X	1	≤ 30
		Output driver and input Schmitt trigger disabled	X	1	= 31

(1) X = don't care

6.14.13 Port P4 (P4.0 to P4.7) Input/Output With Schmitt Trigger (MSP430F677xIPZ Only)

Figure 6-18 shows the port diagram. Table 6-77 summarizes the selection of the pin functions.

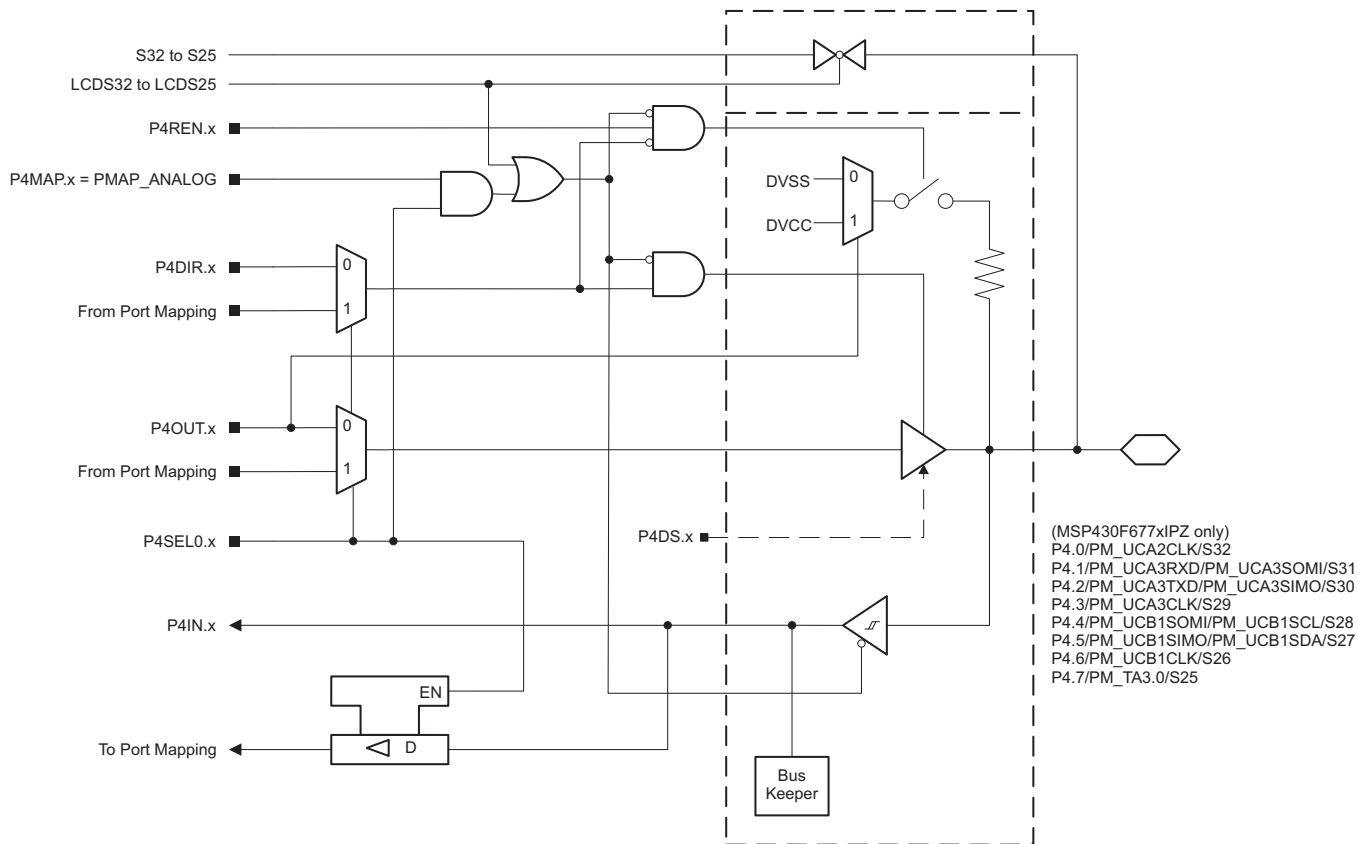

Figure 6-18. Port P4 (P4.0 to P4.7) Diagram (MSP430F677xIPZ Only)

Table 6-77. Port P4 (P4.0 to P4.7) Pin Functions (MSP430F677xIPZ Only)

PIN NAME (P4.x)	x	FUNCTION	CONTROL BITS OR SIGNALS ⁽¹⁾			
			P4DIR.x	P4SEL0.x	P4MAP.x	LCD32 to LCD25
P4.0/PM_UCA2CLK/S32	0	P4.0 (I/O)	I:0; O:1	0	X	0
		Mapped secondary digital function	X	1	≤ 30	0
		Output driver and input Schmitt trigger disabled	X	1	= 31	0
		S32	X	X	X	1
P4.1/PM_UCA3RXD/PM_UCA3SOMI/S31	1	P4.1 (I/O)	I:0; O:1	0	X	0
		Mapped secondary digital function	X	1	≤ 30	0
		Output driver and input Schmitt trigger disabled	X	1	= 31	0
		S31	X	X	X	1
P4.2/PM_UCA3TXD/PM_UCA3SIMO/S30	2	P4.2 (I/O)	I:0; O:1	0	X	0
		Mapped secondary digital function	X	1	≤ 30	0
		Output driver and input Schmitt trigger disabled	X	1	= 31	0
		S30	X	X	X	1
P4.3/PM_UCA3CLK/S29	3	P4.3 (I/O)	I:0; O:1	0	X	0
		Mapped secondary digital function	X	1	≤ 30	0
		Output driver and input Schmitt trigger disabled	X	1	= 31	0
		S29	X	X	X	1
P4.4/PM_UCB1SOMI/PM_UCB1SCL/S28	4	P4.4 (I/O)	I:0; O:1	0	X	0
		Mapped secondary digital function	X	1	≤ 30	0
		Output driver and input Schmitt trigger disabled	X	1	= 31	0
		S28	X	X	X	1
P4.5/PM_UCB1SIMO/PM_UCB1SDA/S27	5	P4.5 (I/O)	I:0; O:1	0	X	0
		Mapped secondary digital function	X	1	≤ 30	0
		Output driver and input Schmitt trigger disabled	X	1	= 31	0
		S27	X	X	X	1
P4.6/PM_UCB1CLK/S26	6	P4.6 (I/O)	I:0; O:1	0	X	0
		Mapped secondary digital function	X	1	≤ 30	0
		Output driver and input Schmitt trigger disabled	X	1	= 31	0
		S26	X	X	X	1
P4.7/PM_TA3.0/S25	7	P4.7 (I/O)	I:0; O:1	0	X	0
		Mapped secondary digital function	X	1	≤ 30	0
		Output driver and input Schmitt trigger disabled	X	1	= 31	0
		S25	X	X	X	1

(1) X = don't care

6.14.14 Port P5 (P5.0 to P5.3) Input/Output With Schmitt Trigger (MSP430F677xIPEU Only)

Figure 6-19 shows the port diagram. Table 6-78 summarizes the selection of the pin functions.

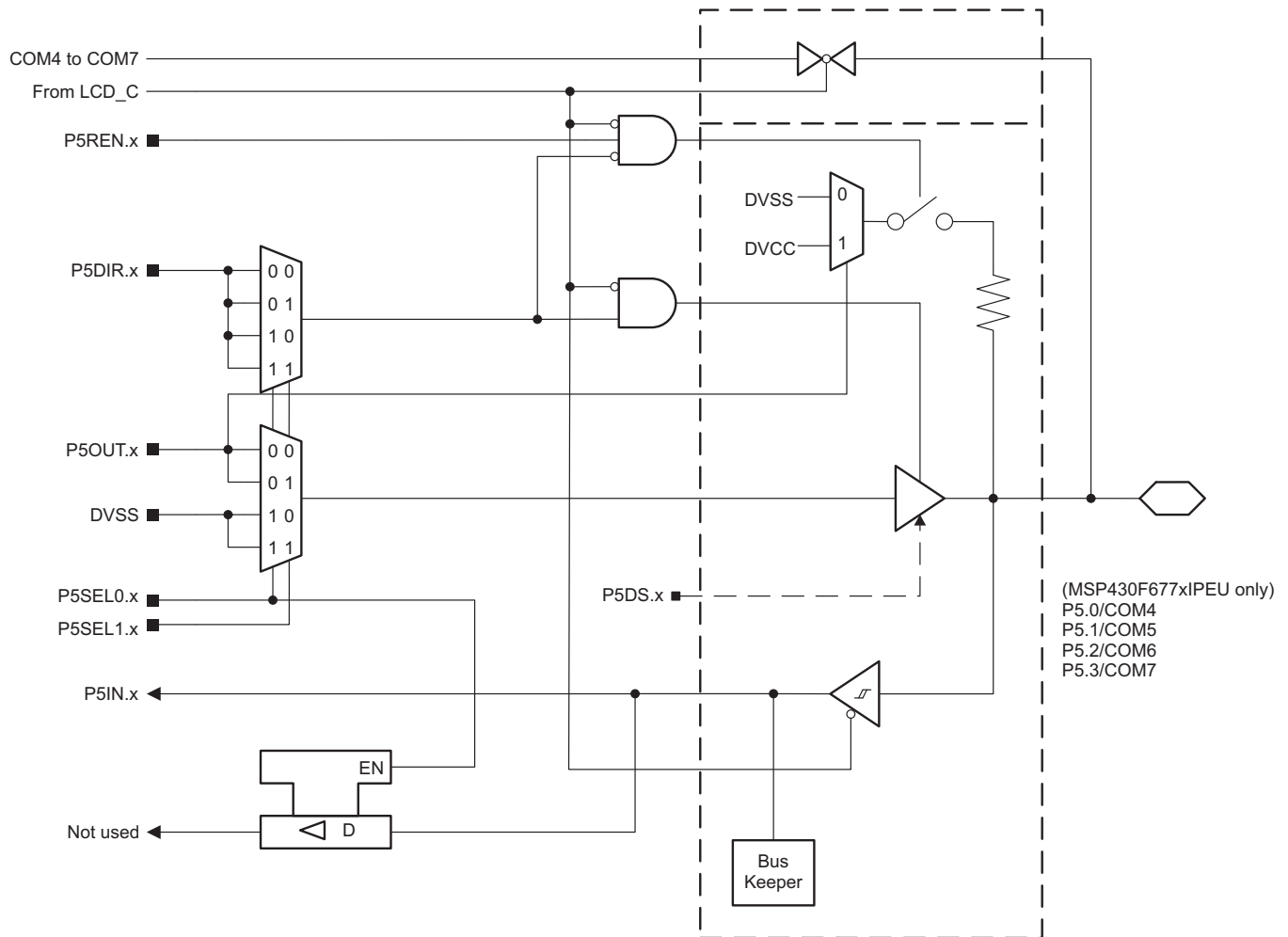

Figure 6-19. Port P5 (P5.0 to P5.3) Diagram (MSP430F677xIPEU Only)

Table 6-78. Port P5 (P5.0 to P5.3) Pin Functions (MSP430F677xIPEU Only)

PIN NAME (P5.x)	x	FUNCTION	CONTROL BITS OR SIGNALS ⁽¹⁾			
			P5DIR.x	P5SEL1.x	P5SEL0.x	COM Enable
P5.0/COM4	0	P5.0 (I/O)	I:0; O:1	X	0	0
		N/A	0	X	1	0
		DVSS	1	X	1	0
		COM4	X	X	X	1
P5.1/COM5	1	P5.1 (I/O)	I:0; O:1	X	0	0
		N/A	0	X	1	0
		DVSS	1	X	1	0
		COM5	X	X	X	1
P5.2/COM6	2	P5.2 (I/O)	I:0; O:1	X	0	0
		N/A	0	X	1	0
		DVSS	1	X	1	0
		COM6	X	X	X	1
P5.3/COM7	3	P5.3 (I/O)	I:0; O:1	X	0	0
		N/A	0	X	1	0
		DVSS	1	X	1	0
		COM7	X	X	X	1

(1) X = don't care

6.14.15 Port P5 (P5.4 to P5.6) Input/Output With Schmitt Trigger (MSP430F677xIPEU Only)

Figure 6-20 shows the port diagram. Table 6-79 summarizes the selection of the pin functions.

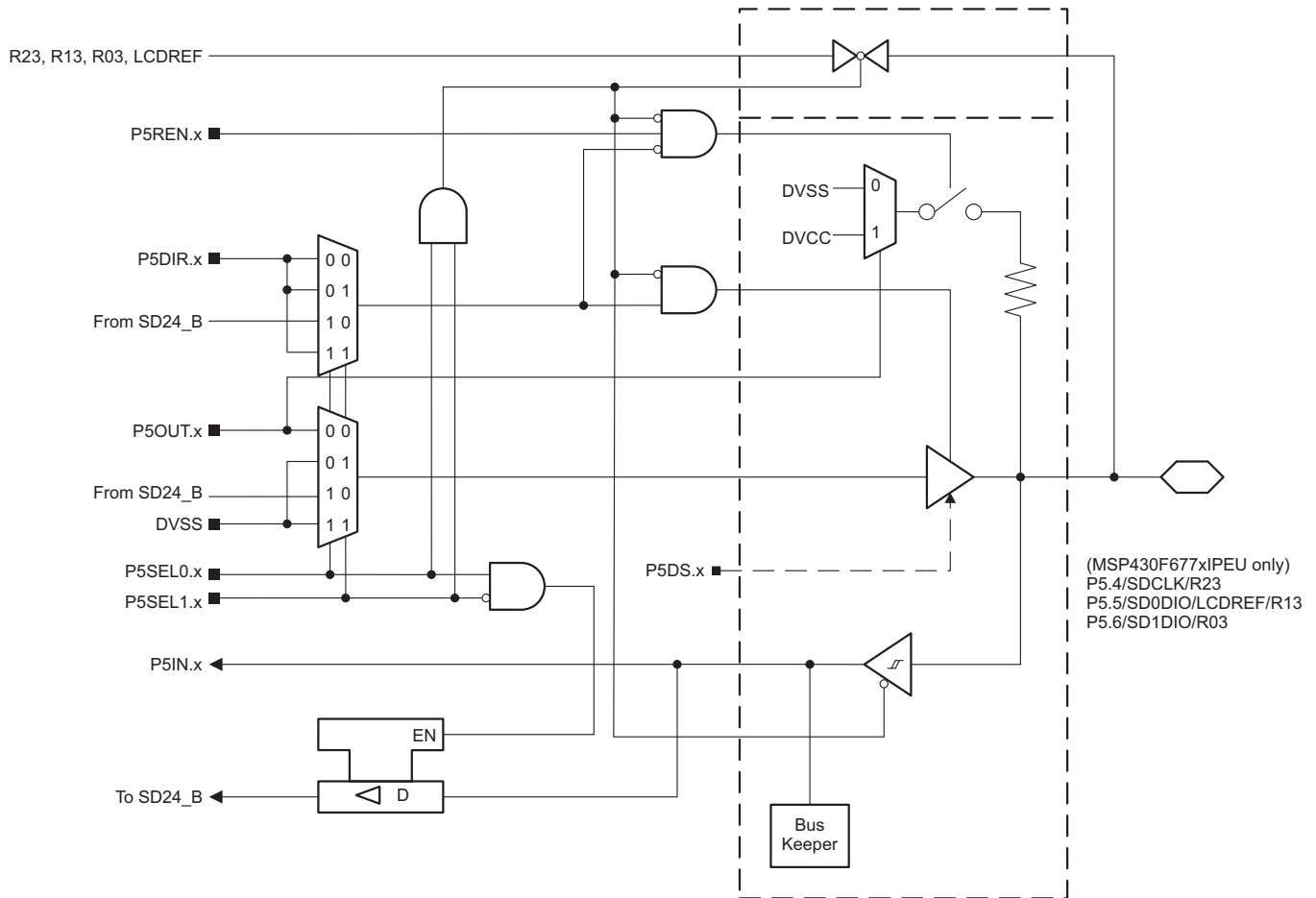

Figure 6-20. Port P5 (P5.4 to P5.6) Diagram (MSP430F677xIPEU Only)

Table 6-79. Port P5 (P5.4 to P5.6) Pin Functions (MSP430F677xIPEU Only)

PIN NAME (P5.x)	x	FUNCTION	CONTROL BITS OR SIGNALS ⁽¹⁾		
			P5DIR.x	P5SEL1.x	P5SEL0.x
P5.4/SDCLK/R23	4	P5.4 (I/O)	I:0; O:1	0	0
		Secondary digital function	X	0	1
		N/A	0	1	0
		DVSS	1	1	0
		R23	X	1	1
P5.5/SD0DIO/LCDREF/R13	5	P5.5 (I/O)	I:0; O:1	0	0
		Secondary digital function	X	0	1
		N/A	0	1	0
		DVSS	1	1	0
		LCDREF/R13	X	1	1
PT.6/SD1DIO/R03	6	P5.6 (I/O)	I:0; O:1	0	0
		Secondary digital function	X	0	1
		N/A	0	1	0
		DVSS	1	1	0
		R03	X	1	1

(1) X = don't care

6.14.16 Port P5 (P5.7) Input/Output With Schmitt Trigger (MSP430F677xIPEU Only)

Figure 6-21 shows the port diagram. Table 6-80 summarizes the selection of the pin functions.

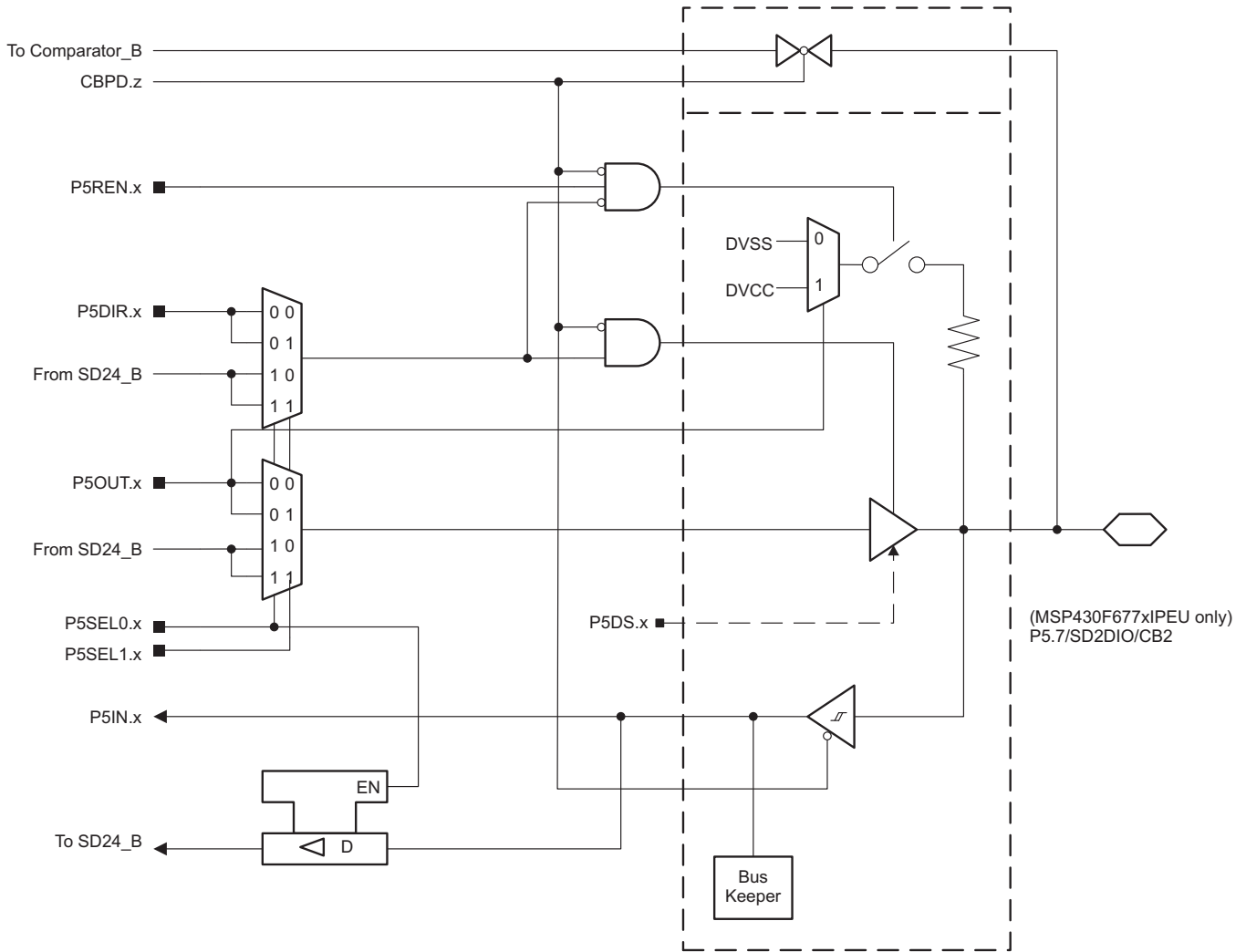

Figure 6-21. Port P5 (P5.7) Diagram (MSP430F677xIPEU Only)

Table 6-80. Port P5 (P5.7) Pin Functions (MSP430F677xIPEU Only)

PIN NAME (P5.x)	x	FUNCTION	CONTROL BITS OR SIGNALS ⁽¹⁾			
			P5DIR.x	P5SEL1.x	P5SEL0.x	CBPD.z
P5.7/SD2DIO/CB2	7	P5.7 (I/O)	I:0; O:1	X	0	0
		Secondary digital function	X	X	1	0
		CB2	X	X	X	1 (z = 2)

(1) X = don't care

6.14.17 Port P5 (P5.0 to P5.7) Input/Output With Schmitt Trigger (MSP430F677xIPZ Only)

Figure 6-22 shows the port diagram. Table 6-81 summarizes the selection of the pin functions.

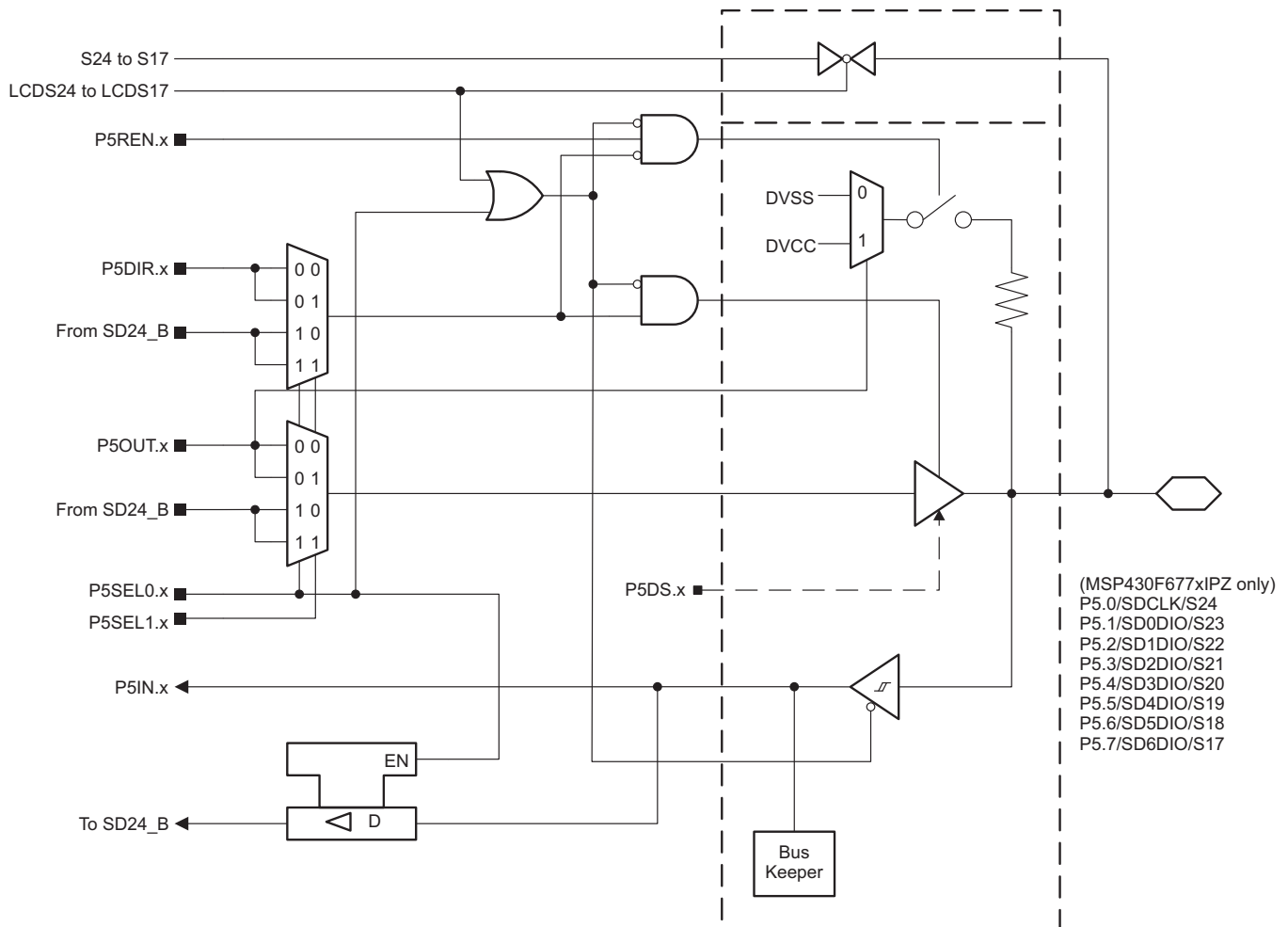

Figure 6-22. Port P5 (P5.0 to P5.7) Diagram (MSP430F677xIPZ Only)

Table 6-81. Port P5 (P5.0 to P5.7) Pin Functions (MSP430F677xIPZ Only)

PIN NAME (P5.x)	x	FUNCTION	CONTROL BITS OR SIGNALS ⁽¹⁾			
			P5DIR.x	P5SEL1.x	P5SEL0.x	LCD24 to LCD17
P5.0/SDCLK/S24	0	P5.0 (I/O)	I:0; O:1	X	0	0
		Secondary digital function	X	X	1	0
		S24	X	X	X	1
P5.1/SD0DIO/S23	1	P5.1 (I/O)	I:0; O:1	X	0	0
		Secondary digital function	X	X	1	0
		S23	X	X	X	1
P5.2/SD1DIO/S22	2	P5.2 (I/O)	I:0; O:1	X	0	0
		Secondary digital function	X	X	1	0
		S22	X	X	X	1
P5.3/SD2DIO/S21	3	P5.3 (I/O)	I:0; O:1	X	0	0
		Secondary digital function	X	X	1	0
		S21	X	X	X	1
P5.4/SD3DIO/S20	4	P5.4 (I/O)	I:0; O:1	X	0	0
		Secondary digital function	X	X	1	0
		S20	X	X	X	1
P5.5/SD4DIO/S19	5	P5.5 (I/O)	I:0; O:1	X	0	0
		Secondary digital function	X	X	1	0
		S19	X	X	X	1
P5.6/SD5DIO/S18	6	P5.6 (I/O)	I:0; O:1	X	0	0
		Secondary digital function	X	X	1	0
		S18	X	X	X	1
P5.7/SD6DIO/S17	7	P5.7 (I/O)	I:0; O:1	X	0	0
		Secondary digital function	X	X	1	0
		S17	X	X	X	1

(1) X = don't care

6.14.18 Port P6 (P6.0) Input/Output With Schmitt Trigger (MSP430F677xIPEU Only)

Figure 6-23 shows the port diagram. Table 6-82 summarizes the selection of the pin functions.

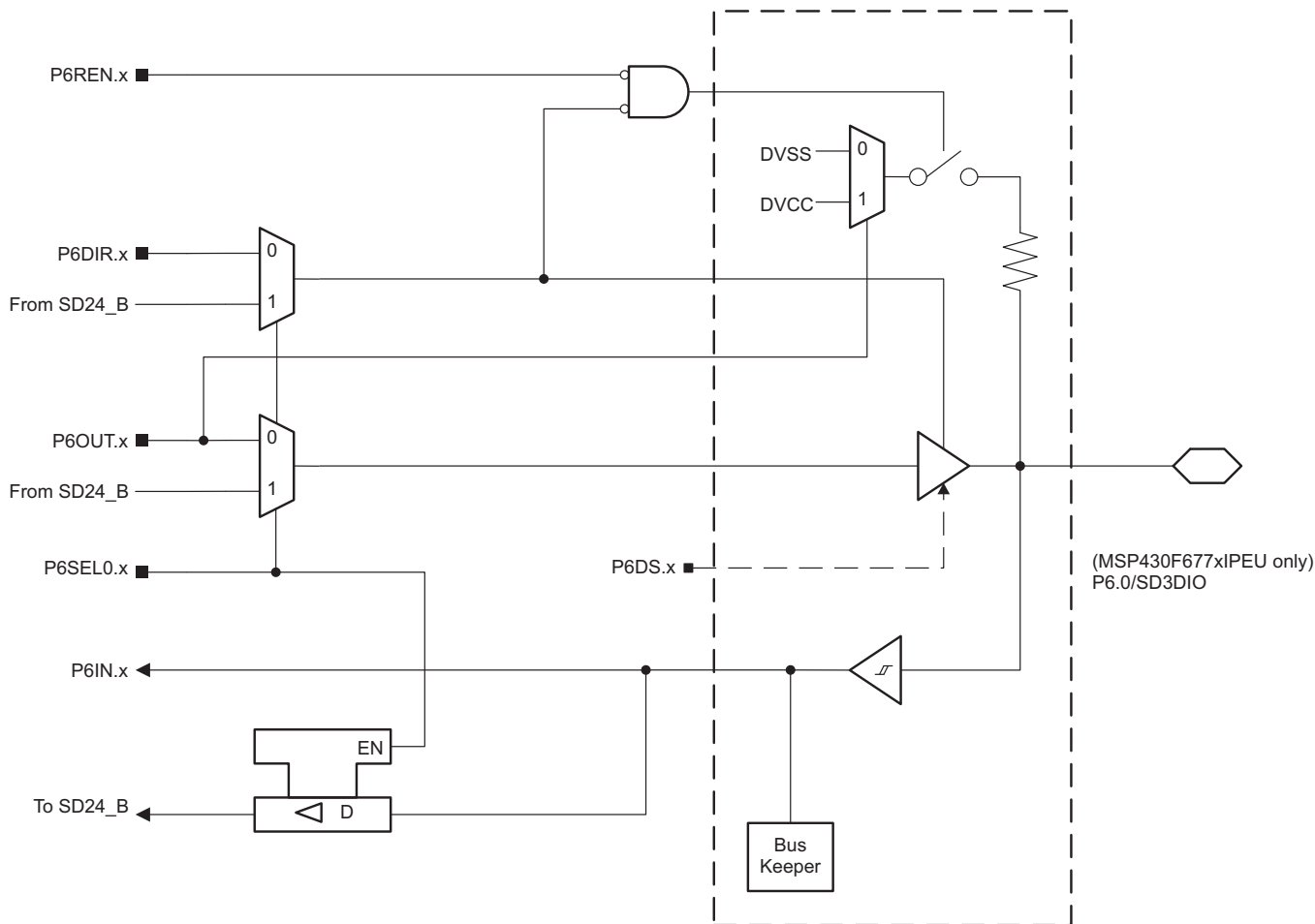

Figure 6-23. Port P6 (P6.0) Diagram (MSP430F677xIPEU Only)

Table 6-82. Port P6 (P6.0) Pin Functions (MSP430F677xIPEU Only)

PIN NAME (P6.x)	x	FUNCTION	CONTROL BITS OR SIGNALS ⁽¹⁾	
			P6DIR.x	P6SEL0.x
P6.0/SD3DIO	0	P6.0 (I/O)	I:0; O:1	0
		Secondary digital function	X	1

(1) X = don't care

6.14.19 Port P6 (P6.1 to P6.3) Input/Output With Schmitt Trigger (MSP430F677xIPEU Only)

Figure 6-24 shows the port diagram. Table 6-83 summarizes the selection of the pin functions.

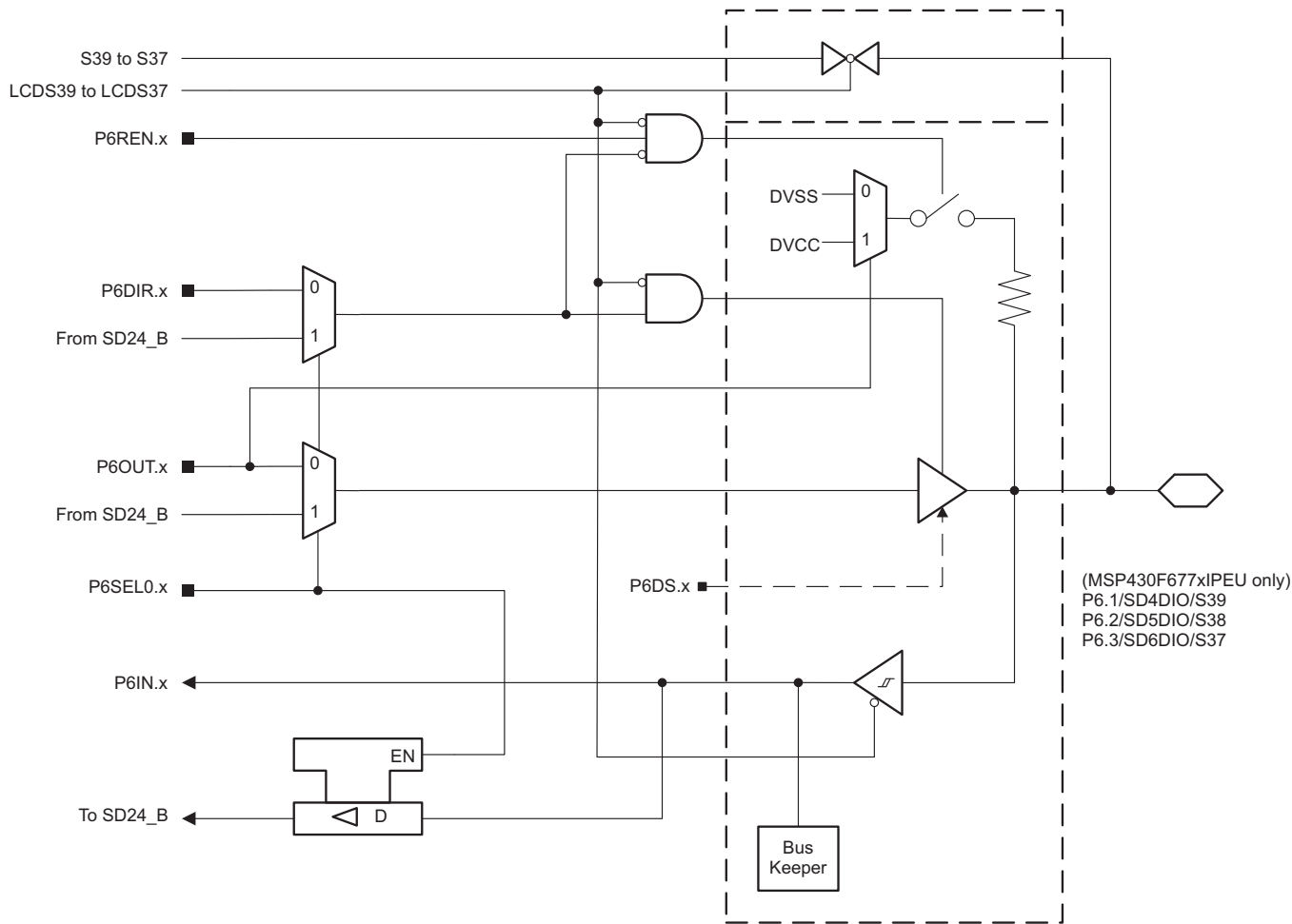

Figure 6-24. Port P6 (P6.1 to P6.3) Diagram (MSP430F677xIPEU Only)

Table 6-83. Port P6 (P6.1 to P6.3) Pin Functions (MSP430F677xIPEU Only)

PIN NAME (P6.x)	x	FUNCTION	CONTROL BITS OR SIGNALS ⁽¹⁾		
			P6DIR.x	P6SEL0.x	LCD39 to LCD37
P6.1/SD4DIO/S39	1	P6.1 (I/O)	I:0; O:1	0	0
		Secondary digital function	X	1	0
		S39	X	X	1
P6.2/SD5DIO/S38	2	P6.2 (I/O)	I:0; O:1	0	0
		Secondary digital function	X	1	0
		S38	X	X	1
P6.3/SD6DIO/S37	3	P6.3 (I/O)	I:0; O:1	0	0
		Secondary digital function	X	1	0
		S37	X	X	1

(1) X = don't care

6.14.20 Port P6 (P6.4 to P6.7) Input/Output With Schmitt Trigger (MSP430F677xIPEU Only)

Figure 6-25 shows the port diagram. Table 6-84 summarizes the selection of the pin functions.

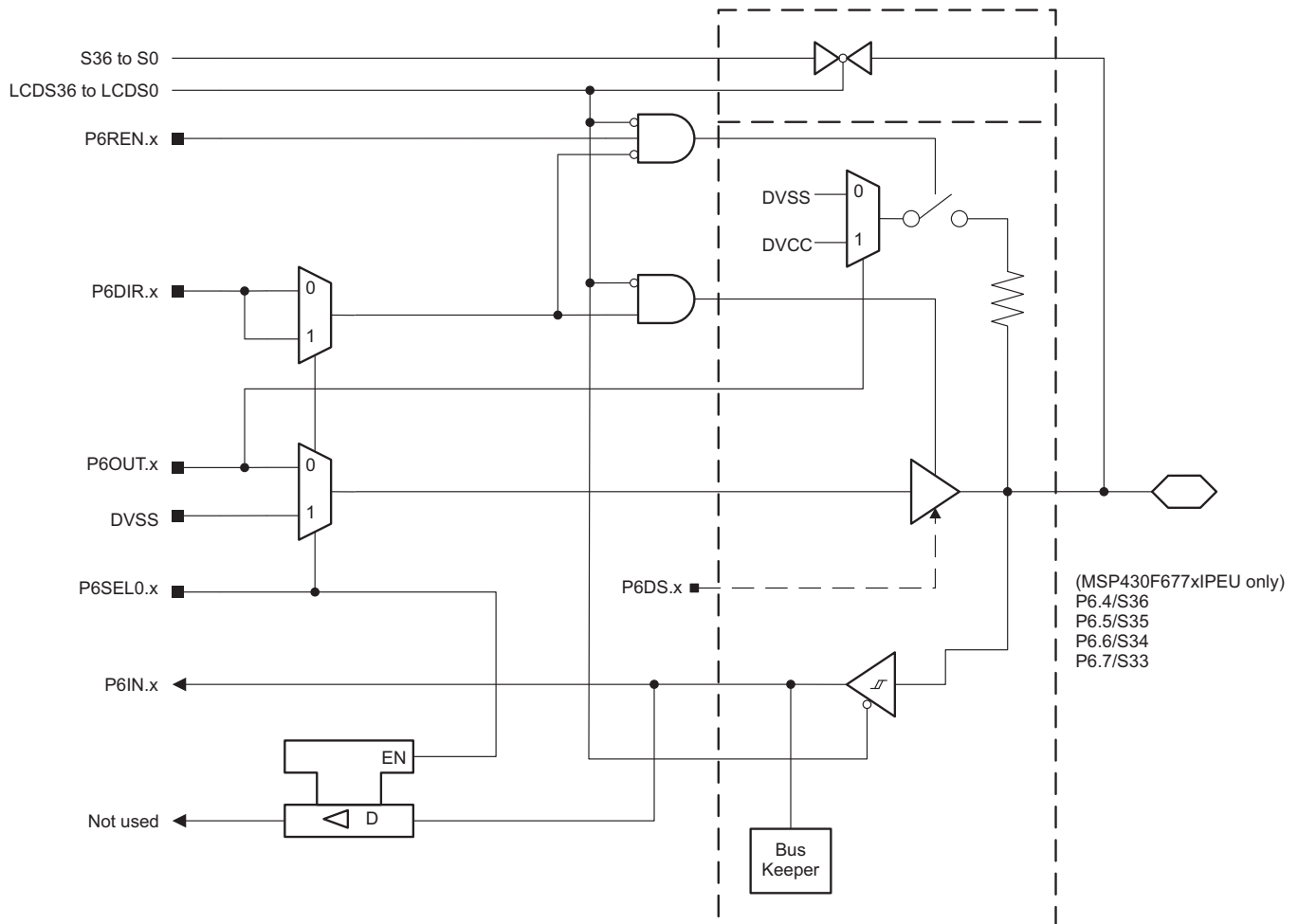

Figure 6-25. Port P6 (P6.4 to P6.7) Diagram (MSP430F67xxIPEU Only)

Table 6-84. Port P6 (P6.4 to P6.7) Pin Functions (MSP430F67xxIPEU Only)

PIN NAME (P6.x)	x	FUNCTION	CONTROL BITS OR SIGNALS ⁽¹⁾		
			P6DIR.x	P6SEL0.x	LCD36 to LCD33
P6.4/S36	4	P6.4 (I/O)	I:0; O:1	0	0
		N/A	0	1	0
		DVSS	1	1	0
		S36	X	X	1
P6.5/S35	5	P6.5 (I/O)	I:0; O:1	0	0
		N/A	0	1	0
		DVSS	1	1	0
		S35	X	X	1
P6.6/S34	6	P6.6(I/O)	I:0; O:1	0	0
		N/A	0	1	0
		DVSS	1	1	0
		S34	X	X	1
P6.7/S33	7	P6.7 (I/O)	I:0; O:1	0	0
		N/A	0	1	0
		DVSS	1	1	0
		S33	X	X	1

(1) X = don't care

6.14.21 Port P6 (P6.0 to P6.7) Input/Output With Schmitt Trigger (MSP430F677xIPZ Only)

Figure 6-26 shows the port diagram. Table 6-85 summarizes the selection of the pin functions.

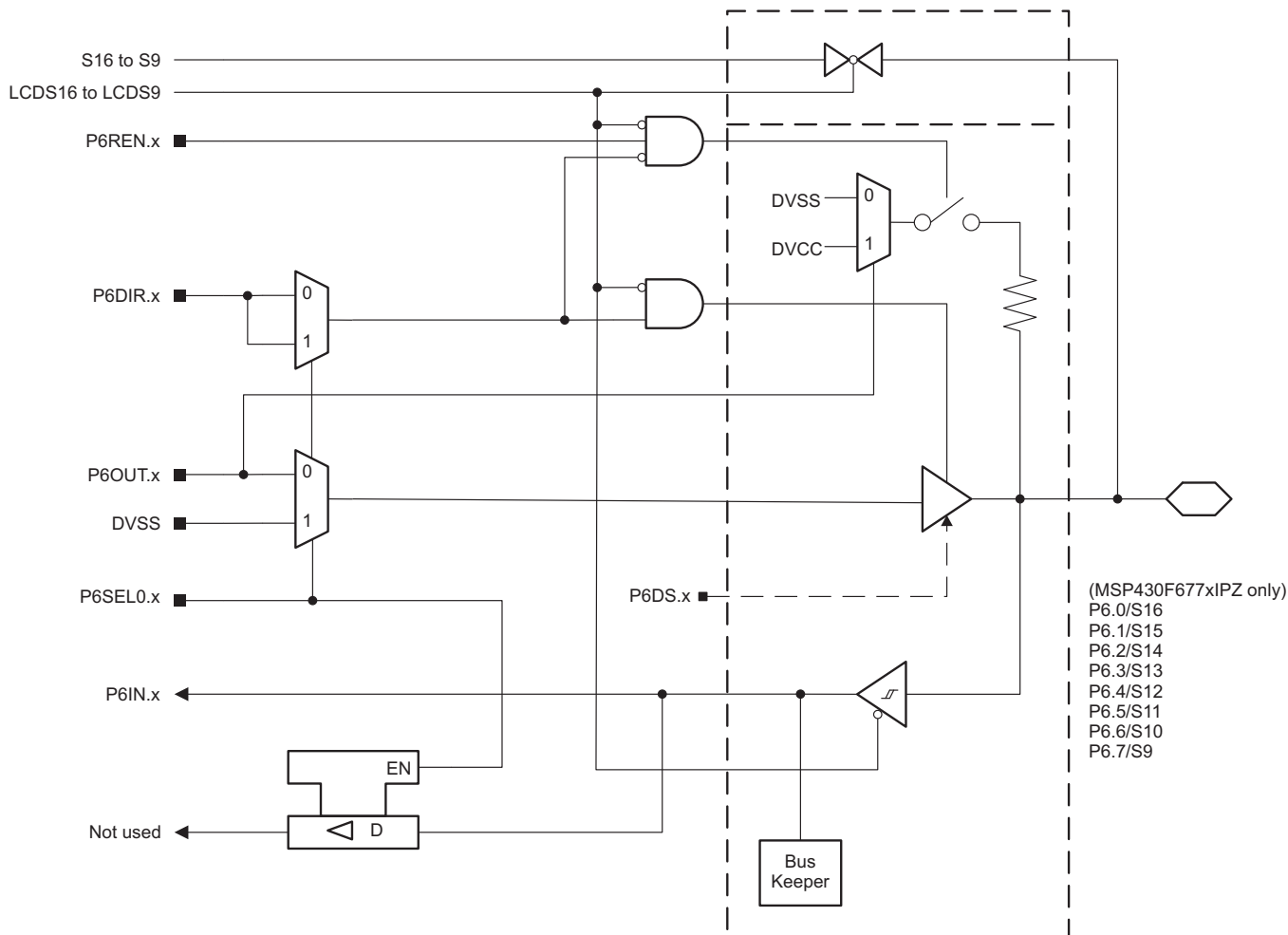

Figure 6-26. Port P6 (P6.0 to P6.7) Diagram (MSP430F67xxIPZ Only)

Table 6-85. Port P6 (P6.0 to P6.7) Pin Functions (MSP430F67xxIPZ Only)

PIN NAME (P6.x)	x	FUNCTION	CONTROL BITS OR SIGNALS ⁽¹⁾		
			P6DIR.x	P6SEL0.x	LCD16 to LCD9
P6.0/S16	0	P6.0 (I/O)	I:0; O:1	0	0
		N/A	0	1	0
		DVSS	1	1	0
		S16	X	X	1
P6.1/S15	1	P6.1 (I/O)	I:0; O:1	0	0
		N/A	0	1	0
		DVSS	1	1	0
		S15	X	X	1
P6.2/S14	2	P6.2 (I/O)	I:0; O:1	0	0
		N/A	0	1	0
		DVSS	1	1	0
		S14	X	X	1
P6.3/S13	3	P6.3 (I/O)	I:0; O:1	0	0
		N/A	0	1	0
		DVSS	1	1	0
		S13	X	X	1
P6.4/S12	4	P6.4 (I/O)	I:0; O:1	0	0
		N/A	0	1	0
		DVSS	1	1	0
		S12	X	X	1
P6.5/S11	5	P6.5 (I/O)	I:0; O:1	0	0
		N/A	0	1	0
		DVSS	1	1	0
		S11	X	X	1
P6.6/S10	6	P6.6 (I/O)	I:0; O:1	0	0
		N/A	0	1	0
		DVSS	1	1	0
		S10	X	X	1
P6.7/S9	7	P6.7 (I/O)	I:0; O:1	0	0
		N/A	0	1	0
		DVSS	1	1	0
		S9	X	X	1

(1) X = don't care

6.14.22 Port P7 (P7.0 to P7.7) Input/Output With Schmitt Trigger (MSP430F67xxIPEU Only)

Figure 6-27 shows the port diagram. Table 6-86 summarizes the selection of the pin functions.

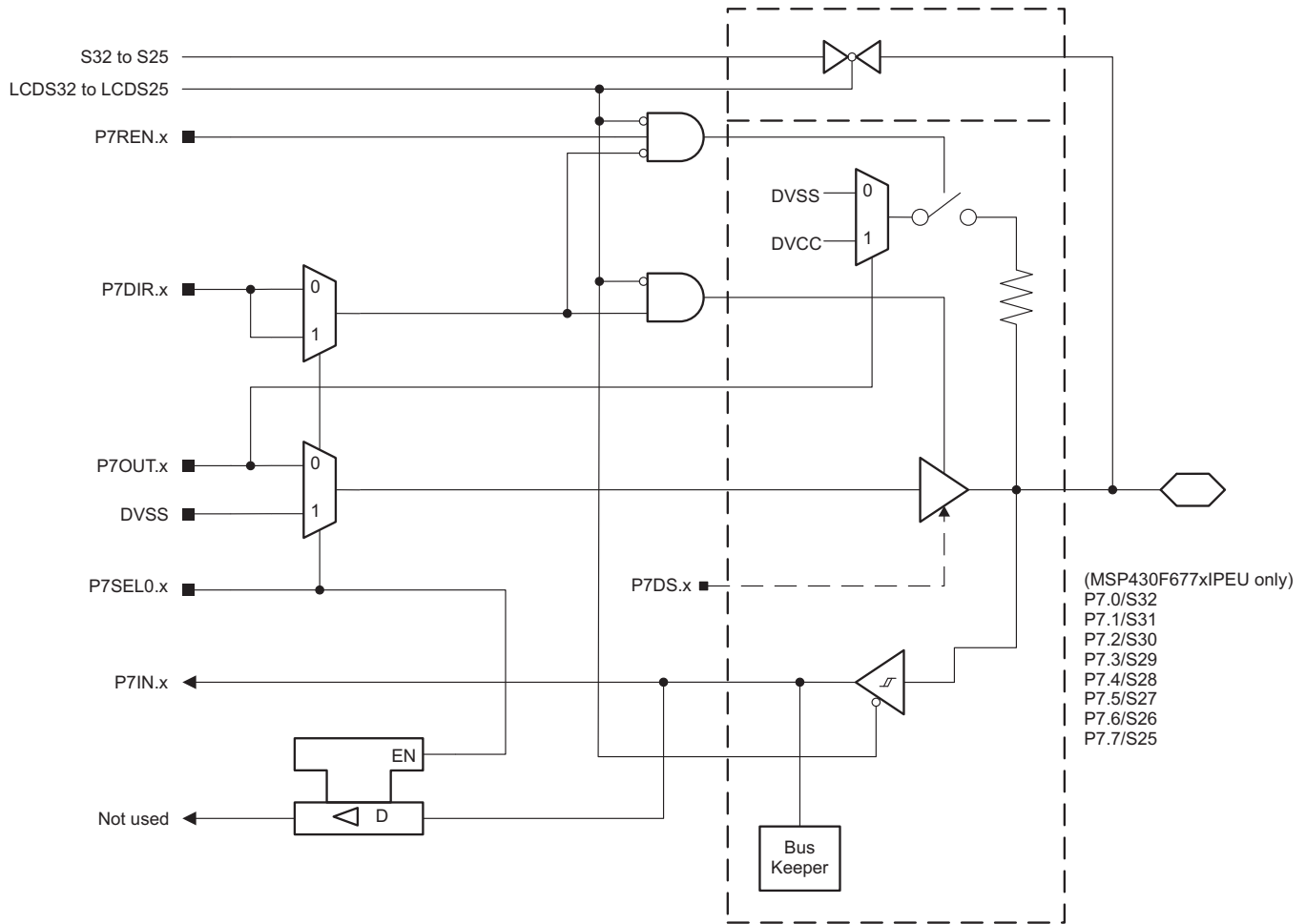

Figure 6-27. Port P7 (P7.0 to P7.7) Diagram (MSP430F67xxIPEU Only)

Table 6-86. Port P7 (P7.0 to P7.7) Pin Functions (MSP430F67xxIPEU Only)

PIN NAME (P7.x)	x	FUNCTION	CONTROL BITS OR SIGNALS ⁽¹⁾		
			P7DIR.x	P7SEL0.x	LCD32 to LCD25
P7.0/S32	0	P7.0 (I/O)	I:0; O:1	0	0
		N/A	0	1	0
		DVSS	1	1	0
		S32	X	X	1
P7.1/S31	1	P7.1 (I/O)	I:0; O:1	0	0
		N/A	0	1	0
		DVSS	1	1	0
		S31	X	X	1
P7.2/S30	2	P7.2 (I/O)	I:0; O:1	0	0
		N/A	0	1	0
		DVSS	1	1	0
		S30	X	X	1
P7.3/S29	3	P7.3 (I/O)	I:0; O:1	0	0
		N/A	0	1	0
		DVSS	1	1	0
		S29	X	X	1
P7.4/S28	4	P7.4 (I/O)	I:0; O:1	0	0
		N/A	0	1	0
		DVSS	1	1	0
		S28	X	X	1
P7.5/S27	5	P7.5 (I/O)	I:0; O:1	0	0
		N/A	0	1	0
		DVSS	1	1	0
		S27	X	X	1
P7.6/S26	6	P7.6 (I/O)	I:0; O:1	0	0
		N/A	0	1	0
		DVSS	1	1	0
		S26	X	X	1
P7.7/S25	7	P7.7 (I/O)	I:0; O:1	0	0
		N/A	0	1	0
		DVSS	1	1	0
		S25	X	X	1

(1) X = don't care

6.14.23 Port P7 (P7.0 to P7.7) Input/Output With Schmitt Trigger (MSP430F67xxIPZ Only)

Figure 6-28 shows the port diagram. Table 6-87 summarizes the selection of the pin functions.

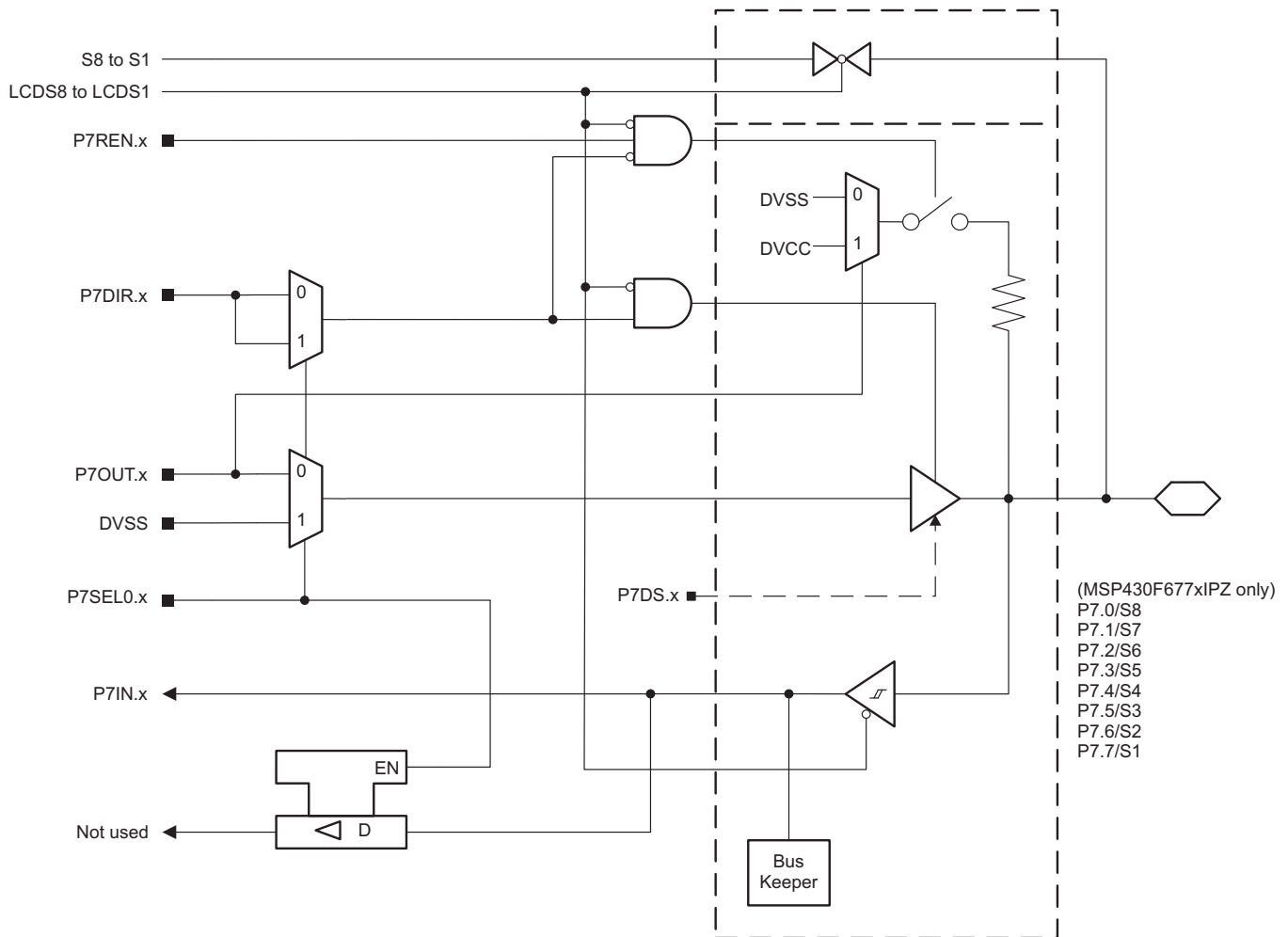

Figure 6-28. Port P7 (P7.0 to P7.7) Diagram (MSP430F67xxIPZ Only)

Table 6-87. Port P7 (P7.0 to P7.7) Pin Functions (MSP430F67xxIPZ Only)

PIN NAME (P7.x)	x	FUNCTION	CONTROL BITS OR SIGNALS ⁽¹⁾		
			P7DIR.x	P7SEL0.x	LCD8 to LCD1
P7.0/S8	0	P7.0 (I/O)	I:0; O:1	0	0
		N/A	0	1	0
		DVSS	1	1	0
		S8	X	X	1
P7.1/S7	1	P7.1 (I/O)	I:0; O:1	0	0
		N/A	0	1	0
		DVSS	1	1	0
		S7	X	X	1
P7.2/S6	2	P7.2 (I/O)	I:0; O:1	0	0
		N/A	0	1	0
		DVSS	1	1	0
		S6	X	X	1
P7.3/S5	3	P7.3 (I/O)	I:0; O:1	0	0
		N/A	0	1	0
		DVSS	1	1	0
		S5	X	X	1
P7.4/S4	4	P7.4 (I/O)	I:0; O:1	0	0
		N/A	0	1	0
		DVSS	1	1	0
		S4	X	X	1
P7.5/S3	5	P7.5 (I/O)	I:0; O:1	0	0
		N/A	0	1	0
		DVSS	1	1	0
		S3	X	X	1
P7.6/S2	6	P7.6 (I/O)	I:0; O:1	0	0
		N/A	0	1	0
		DVSS	1	1	0
		S2	X	X	1
P7.7/S1	7	P7.7 (I/O)	I:0; O:1	0	0
		N/A	0	1	0
		DVSS	1	1	0
		S1	X	X	1

(1) X = don't care

6.14.24 Port P8 (P8.0 to P8.7) Input/Output With Schmitt Trigger (MSP430F677xIPEU Only)

Figure 6-29 shows the port diagram. Table 6-88 summarizes the selection of the pin functions.

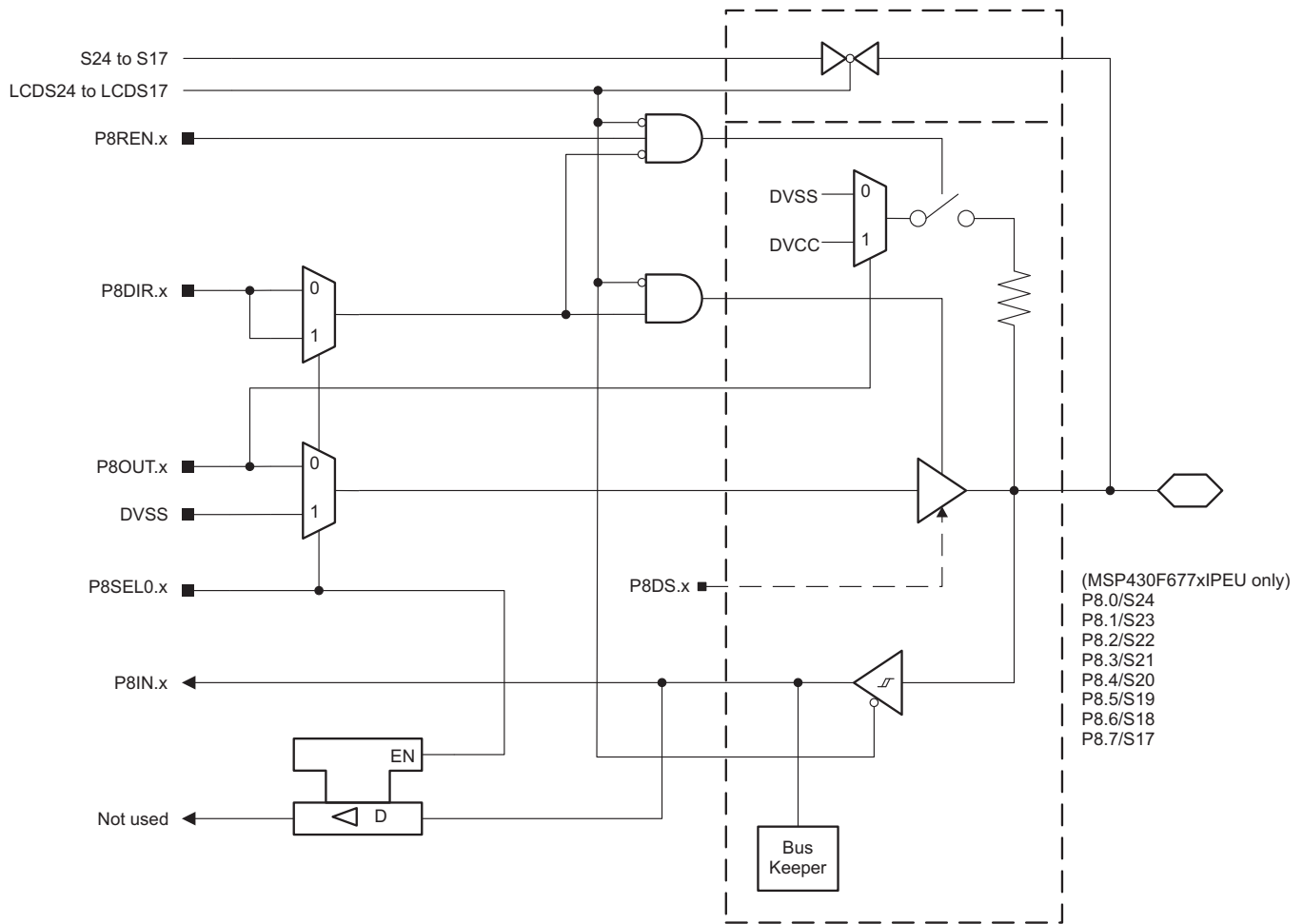

Figure 6-29. Port P8 (P8.0 to P8.7) Diagram (MSP430F677xIPEU Only)

Table 6-88. Port P8 (P8.0 to P8.7) Pin Functions (MSP430F677xIPEU Only)

PIN NAME (P8.x)	x	FUNCTION	CONTROL BITS OR SIGNALS ⁽¹⁾		
			P8DIR.x	P8SEL0.x	LCD24 to LCD17
P8.0/S24	0	P8.0 (I/O)	I:0; O:1	0	0
		N/A	0	1	0
		DVSS	1	1	0
		S24	X	X	1
P8.1/S23	1	P8.1 (I/O)	I:0; O:1	0	0
		N/A	0	1	0
		DVSS	1	1	0
		S23	X	X	1
P8.2/S22	2	P8.2 (I/O)	I:0; O:1	0	0
		N/A	0	1	0
		DVSS	1	1	0
		S22	X	X	1
P8.3/S21	3	P8.3 (I/O)	I:0; O:1	0	0
		N/A	0	1	0
		DVSS	1	1	0
		S21	X	X	1
P8.4/S20	4	P8.4 (I/O)	I:0; O:1	0	0
		N/A	0	1	0
		DVSS	1	1	0
		S20	X	X	1
P8.5/S19	5	P8.5 (I/O)	I:0; O:1	0	0
		N/A	0	1	0
		DVSS	1	1	0
		S19	X	X	1
P8.6/S18	6	P8.6 (I/O)	I:0; O:1	0	0
		N/A	0	1	0
		DVSS	1	1	0
		S18	X	X	1
P8.7/S17	7	P8.7 (I/O)	I:0; O:1	0	0
		N/A	0	1	0
		DVSS	1	1	0
		S17	X	X	1

(1) X = don't care

6.14.25 Port P8 (P8.0) Input/Output With Schmitt Trigger (MSP430F677xIPZ Only)

Figure 6-30 shows the port diagram. Table 6-89 summarizes the selection of the pin functions.

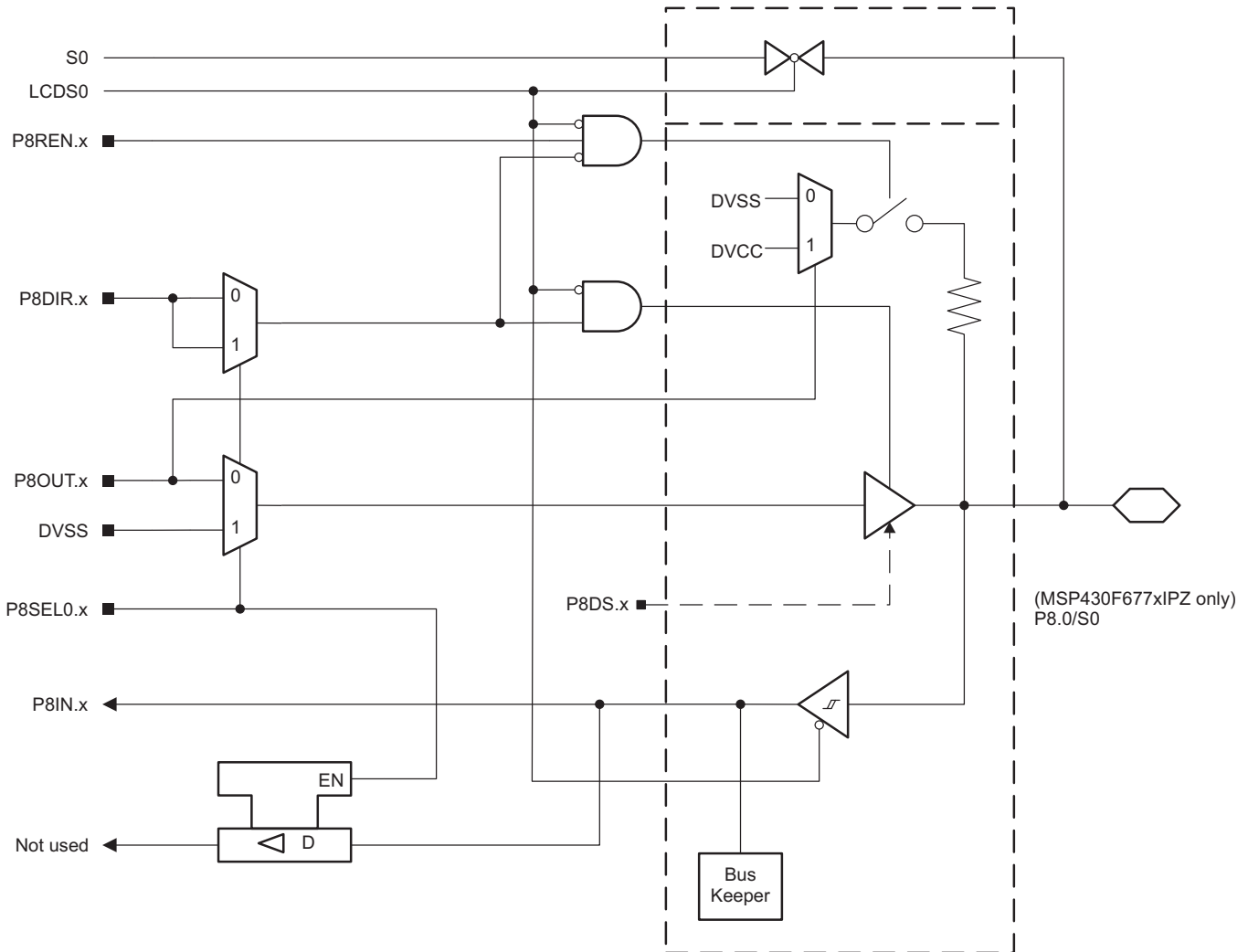

Figure 6-30. Port P8 (P8.0) Diagram (MSP430F677xIPZ Only)

Table 6-89. Port P8 (P8.0) Pin Functions (MSP430F677xIPZ Only)

PIN NAME (P8.x)	x	FUNCTION	CONTROL BITS OR SIGNALS ⁽¹⁾		
			P8DIR.x	P8SEL0.x	LCD0
P8.0/S0	0	P8.0 (I/O)	I:0; O:1	0	0
		N/A	0	1	0
		DVSS	1	1	0
		S0	X	X	1

(1) X = don't care

6.14.26 Port P8 (P8.1) Input/Output With Schmitt Trigger (MSP430F677xIPZ Only)

Figure 6-31 shows the port diagram. Table 6-90 summarizes the selection of the pin functions.

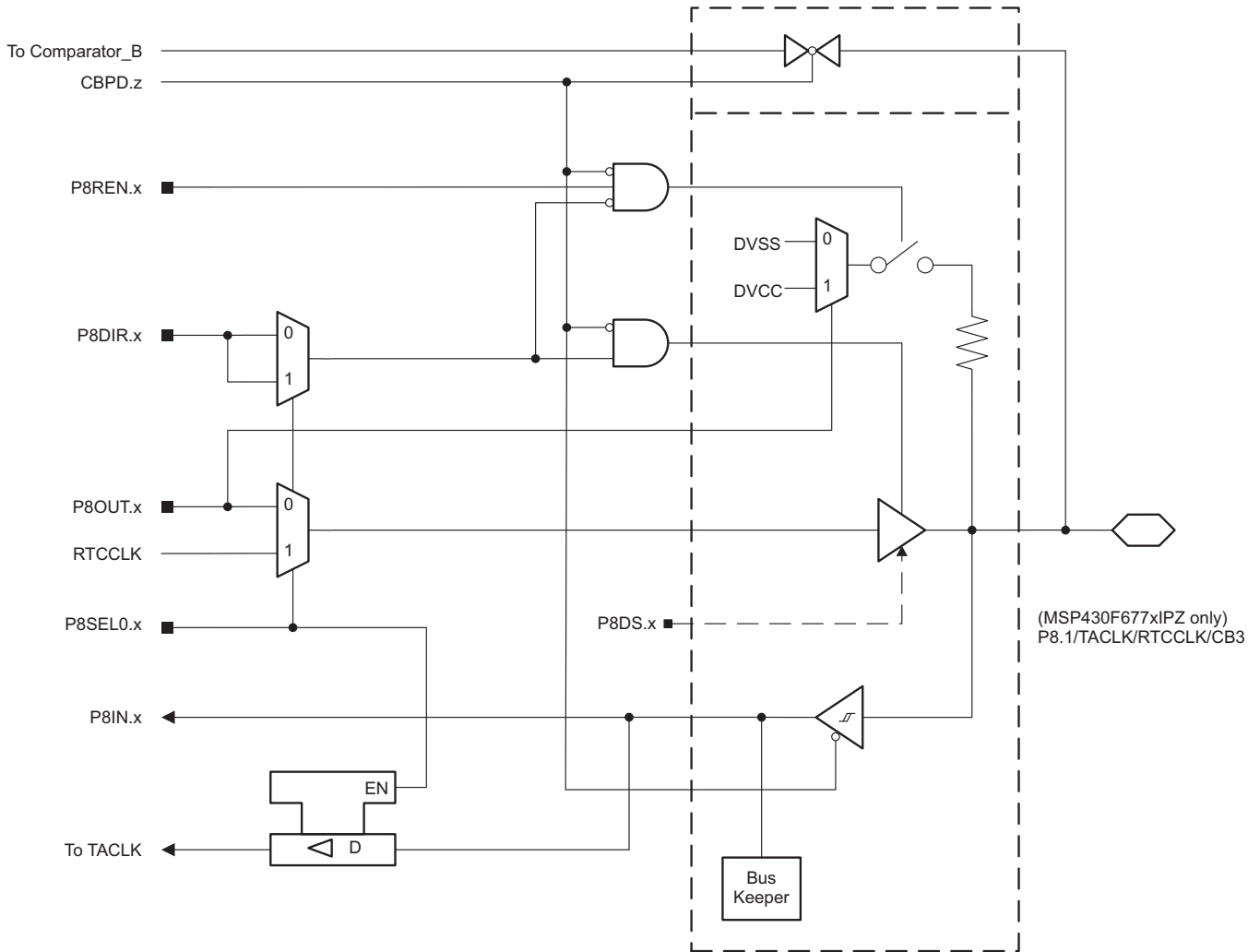

Figure 6-31. Port P8 (P8.1) Diagram (MSP430F677xIPZ Only)

Table 6-90. Port P8 (P8.1) Pin Functions (MSP430F677xIPZ Only)

PIN NAME (P8.x)	x	FUNCTION	CONTROL BITS OR SIGNALS ⁽¹⁾		
			P8DIR.x	P8SEL0.x	CBPD.z
P8.1/TACLK/RTCCLK/CB3	1	P8.1 (I/O)	I:0; O:1	0	0
		TACLK	0	1	0
		RTCCLK	1	1	0
		CB3	X	X	1 (z = 3)

(1) X = don't care

6.14.27 Port P9 (P9.0 to P9.7) Input/Output With Schmitt Trigger (MSP430F677xIPEU Only)

Figure 6-32 shows the port diagram. Table 6-91 summarizes the selection of the pin functions.

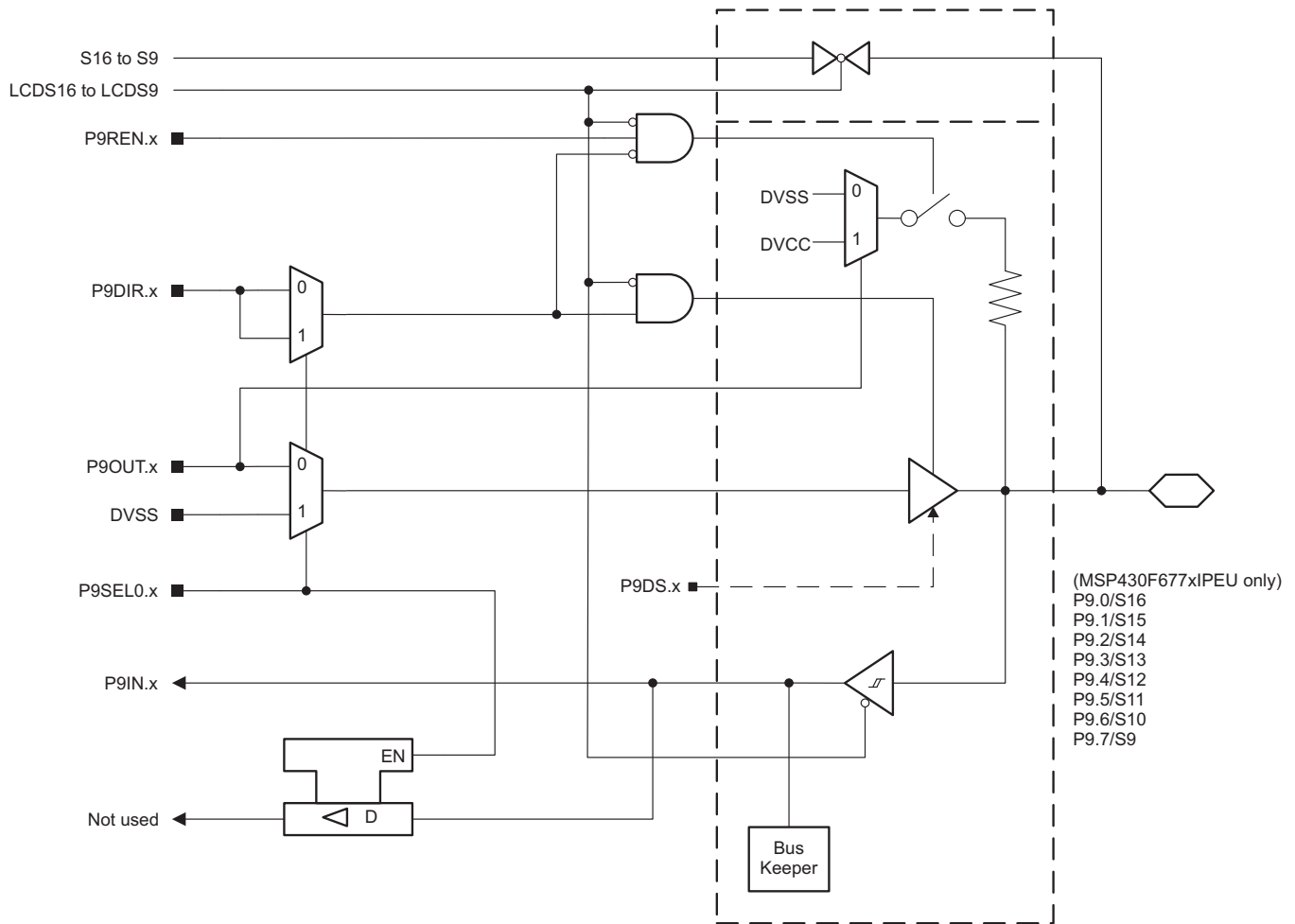

Figure 6-32. Port P9 (P9.0 to P9.7) Diagram (MSP430F677xIPEU Only)

Table 6-91. Port P9 (P9.0 to P9.7) Pin Functions (MSP430F677xIPEU Only)

PIN NAME (P9.x)	x	FUNCTION	CONTROL BITS OR SIGNALS ⁽¹⁾		
			P9DIR.x	P9SEL0.x	LCD16 to LCD9
P9.0/S16	0	P9.0 (I/O)	I:0; O:1	0	0
		N/A	0	1	0
		DVSS	1	1	0
		S16	X	X	1
P9.1/S15	1	P9.1 (I/O)	I:0; O:1	0	0
		N/A	0	1	0
		DVSS	1	1	0
		S15	X	X	1
P9.2/S14	2	P9.2 (I/O)	I:0; O:1	0	0
		N/A	0	1	0
		DVSS	1	1	0
		S14	X	X	1
P9.3/S13	3	P9.3 (I/O)	I:0; O:1	0	0
		N/A	0	1	0
		DVSS	1	1	0
		S13	X	X	1
P9.4/S12	4	P9.4 (I/O)	I:0; O:1	0	0
		N/A	0	1	0
		DVSS	1	1	0
		S12	X	X	1
P9.5/S11	5	P9.5 (I/O)	I:0; O:1	0	0
		N/A	0	1	0
		DVSS	1	1	0
		S11	X	X	1
P9.6/S10	6	P9.6 (I/O)	I:0; O:1	0	0
		N/A	0	1	0
		DVSS	1	1	0
		S10	X	X	1
P9.7/S9	7	P9.7 (I/O)	I:0; O:1	0	0
		N/A	0	1	0
		DVSS	1	1	0
		S9	X	X	1

(1) X = don't care

6.14.28 Port P10 (P10.0 to P10.7) Input/Output With Schmitt Trigger (MSP430F677xIPEU Only)

Figure 6-33 shows the port diagram. Table 6-92 summarizes the selection of the pin functions.

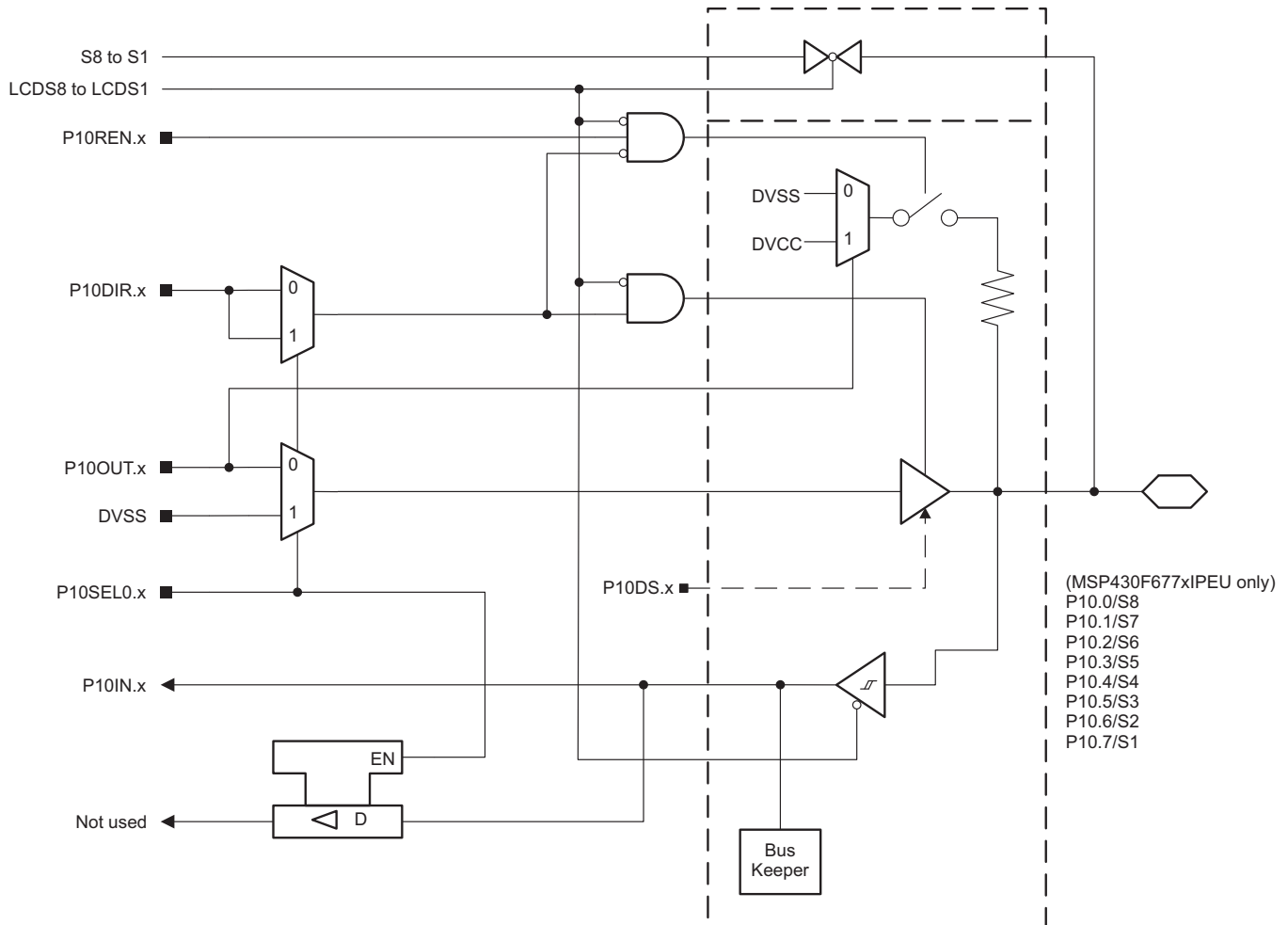

Figure 6-33. Port P10 (P10.0 to P10.7) Diagram (MSP430F677xIPEU Only)

Table 6-92. Port P10 (P10.0 to P10.7) Pin Functions (MSP430F677xIPEU Only)

PIN NAME (P10.x)	x	FUNCTION	CONTROL BITS OR SIGNALS ⁽¹⁾		
			P10DIR.x	P10SEL0.x	LCD8 to LCD1
P10.0/S8	0	P10.0 (I/O)	I:0; O:1	0	0
		N/A	0	1	0
		DVSS	1	1	0
		S8	X	X	1
P10.1/S7	1	P10.1 (I/O)	I:0; O:1	0	0
		N/A	0	1	0
		DVSS	1	1	0
		S7	X	X	1
P10.2/S6	2	P10.2 (I/O)	I:0; O:1	0	0
		N/A	0	1	0
		DVSS	1	1	0
		S6	X	X	1
P10.3/S5	3	P10.3 (I/O)	I:0; O:1	0	0
		N/A	0	1	0
		DVSS	1	1	0
		S5	X	X	1
P10.4/S4	4	P10.4 (I/O)	I:0; O:1	0	0
		N/A	0	1	0
		DVSS	1	1	0
		S4	X	X	1
P10.5/S3	5	P10.5 (I/O)	I:0; O:1	0	0
		N/A	0	1	0
		DVSS	1	1	0
		S3	X	X	1
P10.6/S2	6	P10.6 (I/O)	I:0; O:1	0	0
		N/A	0	1	0
		DVSS	1	1	0
		S2	X	X	1
P10.7/S1	7	P10.7 (I/O)	I:0; O:1	0	0
		N/A	0	1	0
		DVSS	1	1	0
		S1	X	X	1

(1) X = don't care

6.14.29 Port P11 (P11.0) Input/Output With Schmitt Trigger (MSP430F677xIPEU Only)

Figure 6-34 shows the port diagram. Table 6-93 summarizes the selection of the pin functions.

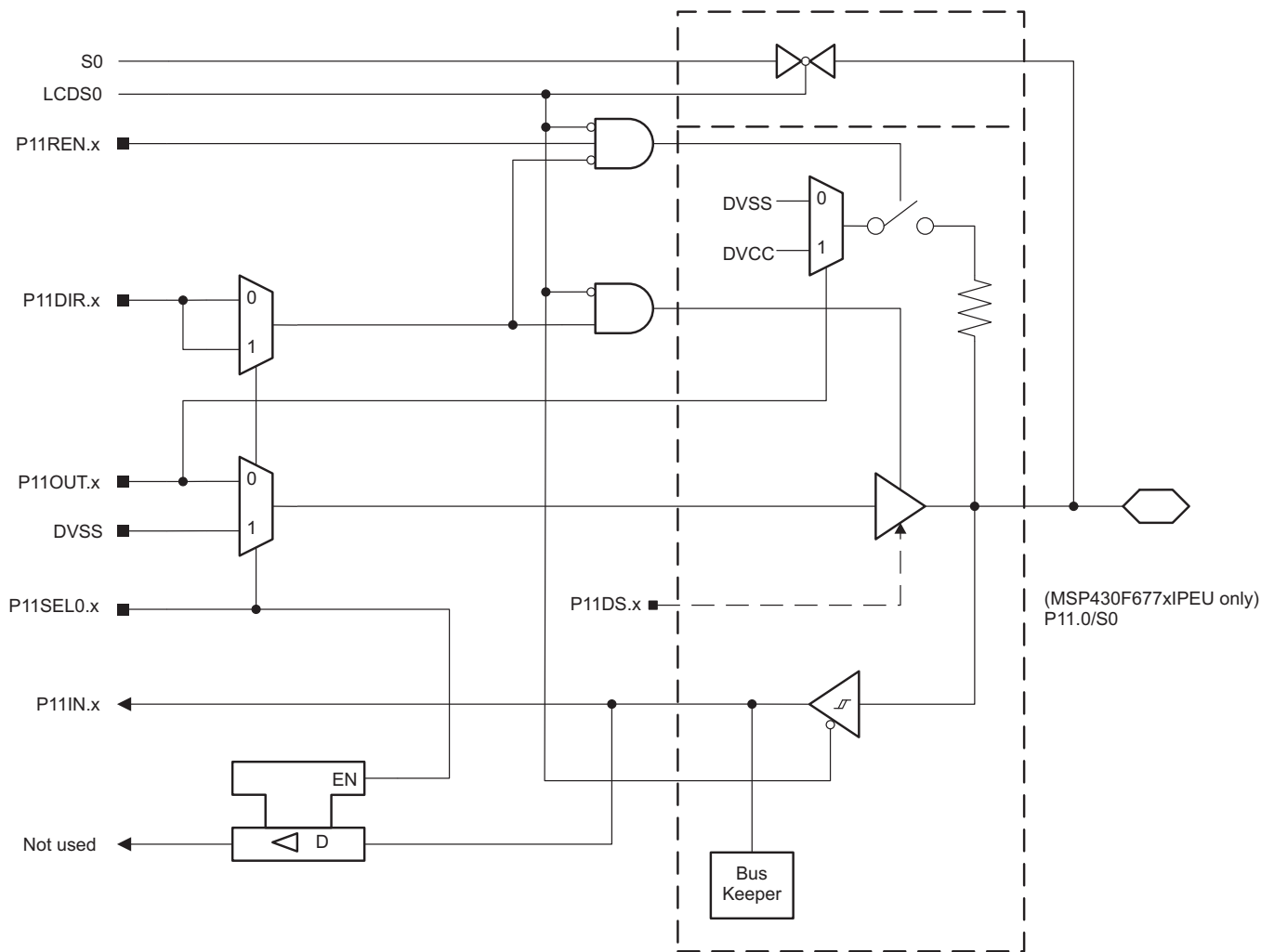

Figure 6-34. Port P11 (P11.0) Diagram (MSP430F677xIPEU Only)

Table 6-93. Port P11 (P11.0) Pin Functions (MSP430F677xIPEU Only)

PIN NAME (P11.x)	x	FUNCTION	CONTROL BITS OR SIGNALS ⁽¹⁾		
			P11DIR.x	P11SEL0.x	LCD0
P11.0/S0	0	P11.0 (I/O)	I:0; O:1	0	0
		N/A	0	1	0
		DVSS	1	1	0
		S0	X	X	1

(1) X = don't care

6.14.30 Port P11 (P11.1) Input/Output With Schmitt Trigger (MSP430F677xIPEU Only)

Figure 6-35 shows the port diagram. Table 6-94 summarizes the selection of the pin functions.

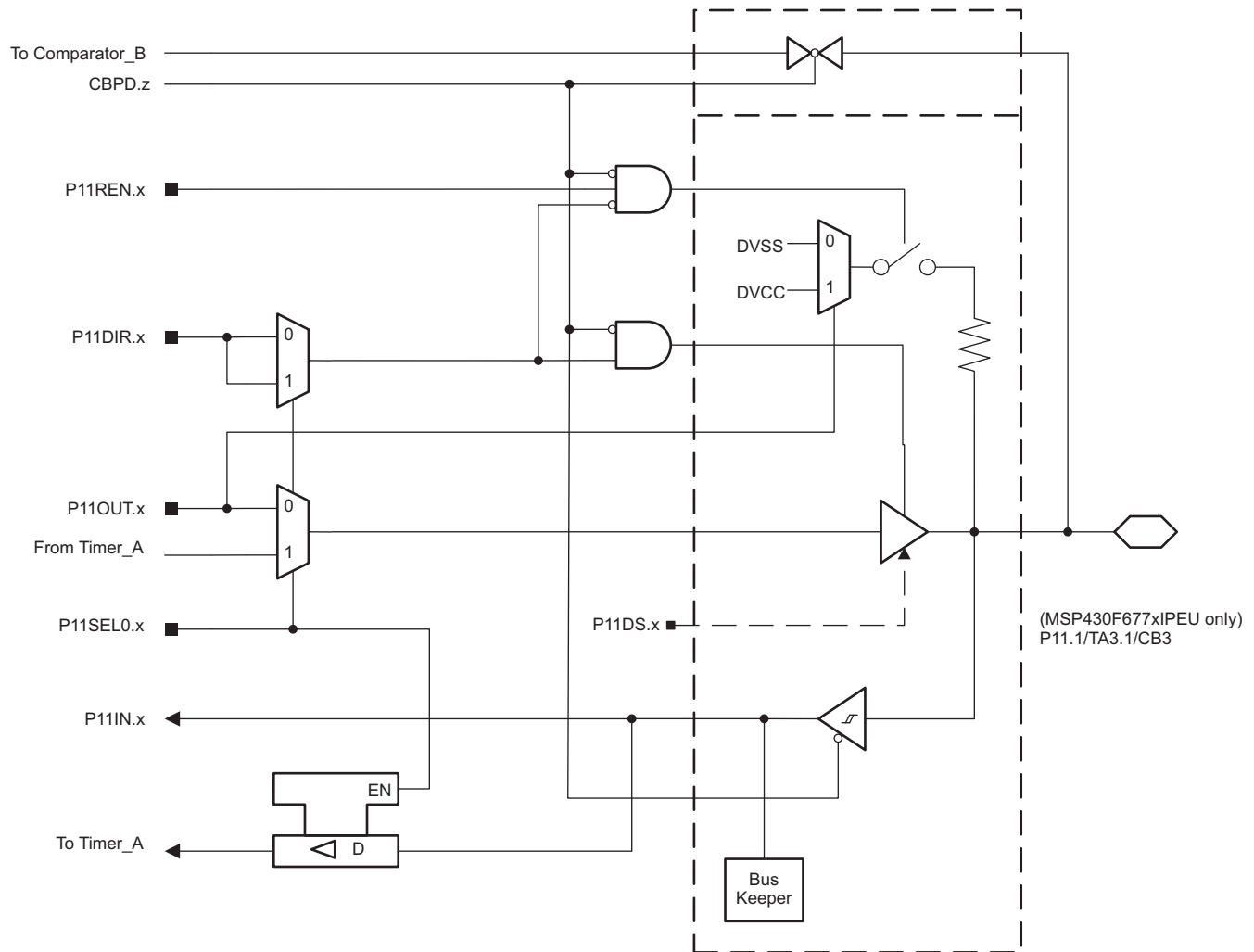

Figure 6-35. Port P11 (P11.1) Diagram (MSP430F677xIPEU Only)

Table 6-94. Port P11 (P11.1) Pin Functions (MSP430F677xIPEU Only)

PIN NAME (P11.x)	x	FUNCTION	CONTROL BITS OR SIGNALS ⁽¹⁾		
			P11DIR.x	P11SEL0.x	CBPD.z
P11.1/TA3.1/CB3	1	P11.1 (I/O)	I:0; O:1	0	0
		TA3.CC1A	0	1	0
		TA3.1	1	1	0
		CB3	X	X	1

(1) X = don't care

6.14.31 Port P11 (P11.2 and P11.3) Input/Output With Schmitt Trigger (MSP430F677xIPEU Only)

Figure 6-36 shows the port diagram. Table 6-95 summarizes the selection of the pin functions.

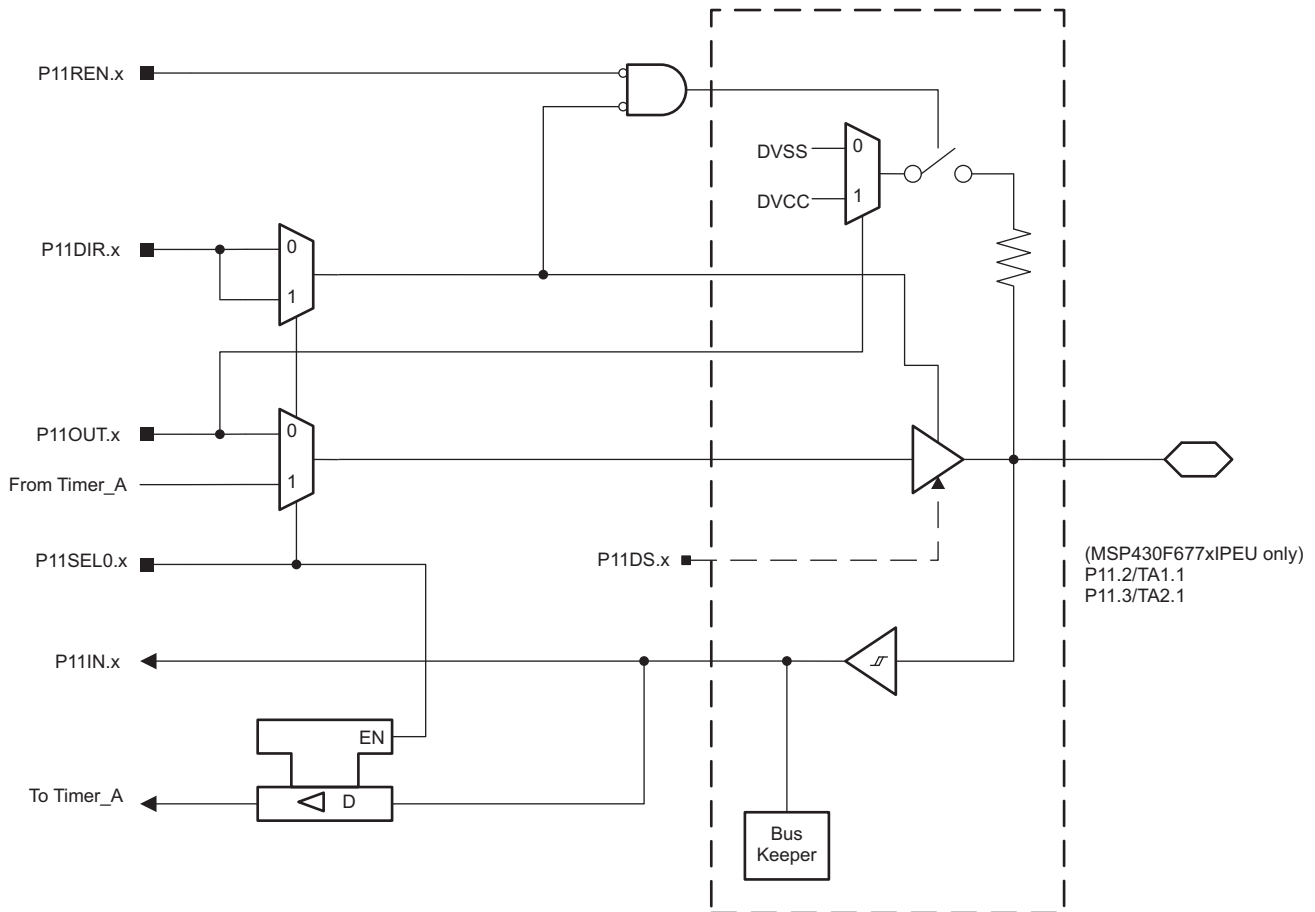

Figure 6-36. Port P11 (P11.2 and P11.3) Diagram (MSP430F677xIPEU Only)

Table 6-95. Port P11 (P11.2 and P11.3) Pin Functions (MSP430F677xIPEU Only)

PIN NAME (P11.x)	x	FUNCTION	CONTROL BITS OR SIGNALS	
			P11DIR.x	P11SEL0.x
P11.2/TA1.1	2	P11.2 (I/O)	I:0; O:1	0
		TA1.CC1A	0	1
		TA1.1	1	1
P11.3/TA2.1	3	P11.3 (I/O)	I:0; O:1	0
		TA2.CC1A	0	1
		TA2.1	1	1

6.14.32 Port P11 (P11.4 and P11.5) Input/Output With Schmitt Trigger (MSP430F677xIPEU Only)

Figure 6-37 shows the port diagram. Table 6-96 summarizes the selection of the pin functions.

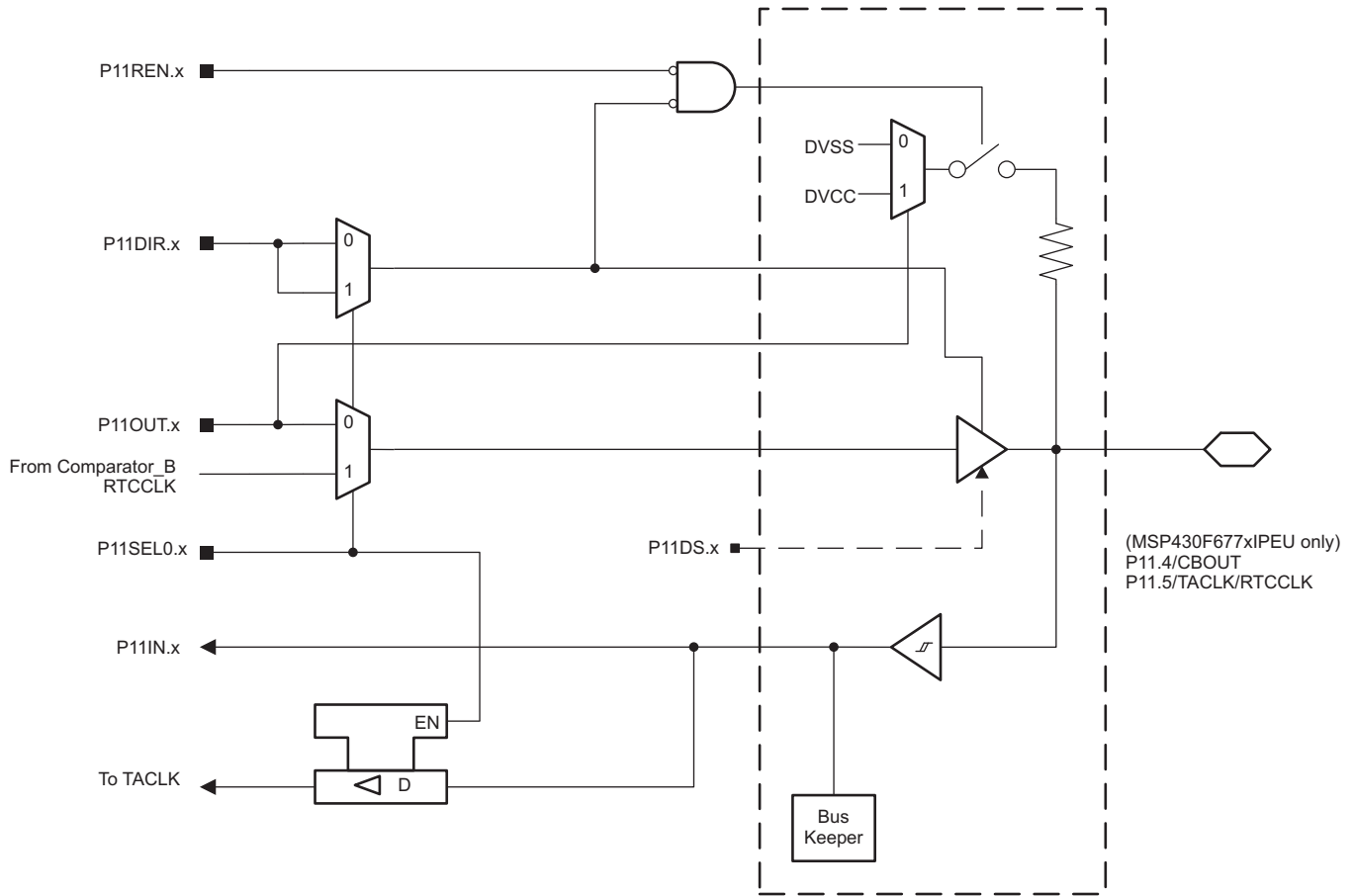

Figure 6-37. Port P11 (P11.4 and P11.5) Diagram (MSP430F677xIPEU Only)

Table 6-96. Port P11 (P11.4 and P11.5) Pin Functions (MSP430F677xIPEU Only)

PIN NAME (P11.x)	x	FUNCTION	CONTROL BITS OR SIGNALS	
			P11DIR.x	P11SEL0.x
P11.4/CBOUT	4	P11.4 (I/O)	I:0; O:1	0
		N/A	0	1
		CBOUT	1	1
P11.5/TACLK/RTCCLK	5	P11.5 (I/O)	I:0; O:1	0
		TACLK	0	1
		RTCCLK	1	1

6.14.33 Port PJ (PJ.0) JTAG Pin TDO, Input/Output With Schmitt Trigger or Output

Figure 6-38 shows the port diagram. Table 6-97 summarizes the selection of the pin functions.

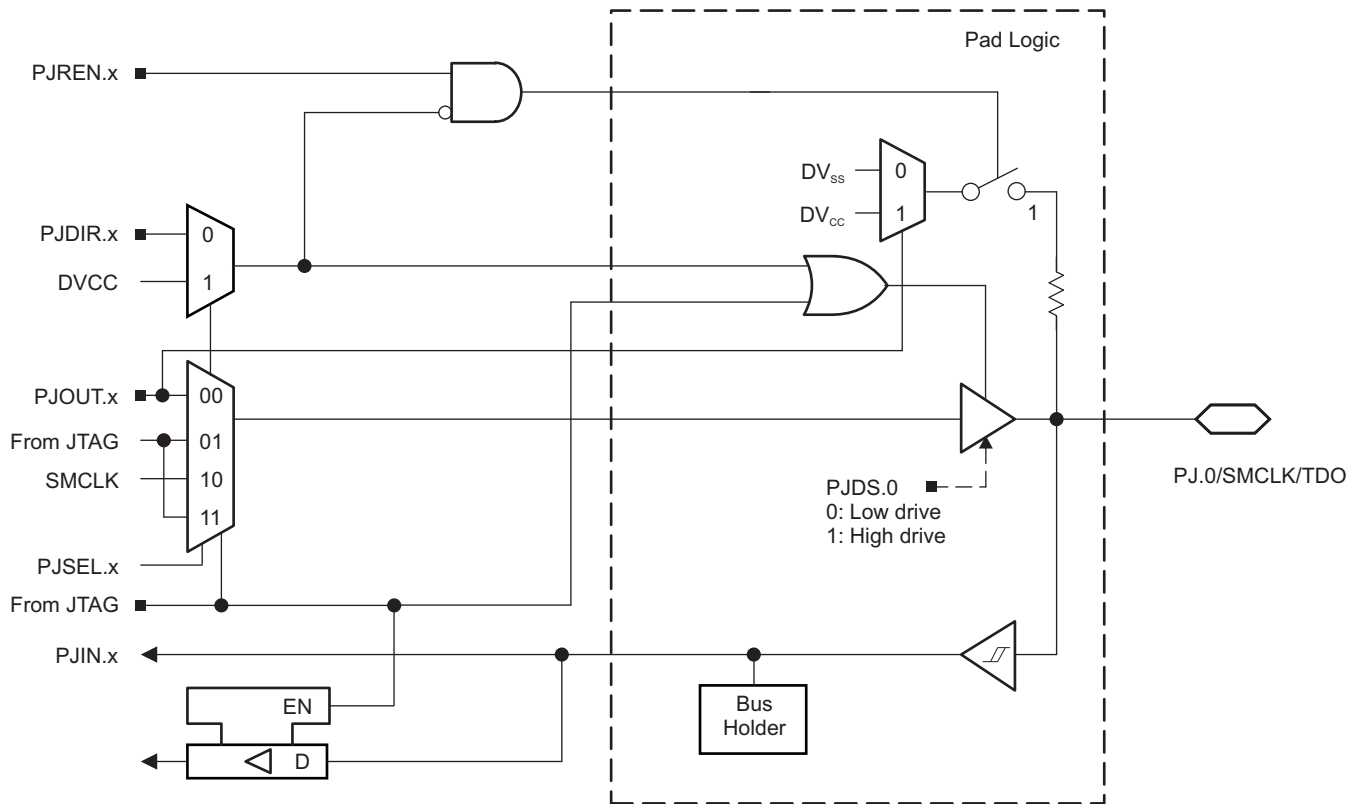

Figure 6-38. Port PJ (PJ.0) Diagram

6.14.34 Port PJ (PJ.1 to PJ.3) JTAG Pins TMS, TCK, TDI/TCLK, Input/Output With Schmitt Trigger or Output

Figure 6-39 shows the port diagram. Table 6-97 summarizes the selection of the pin functions.

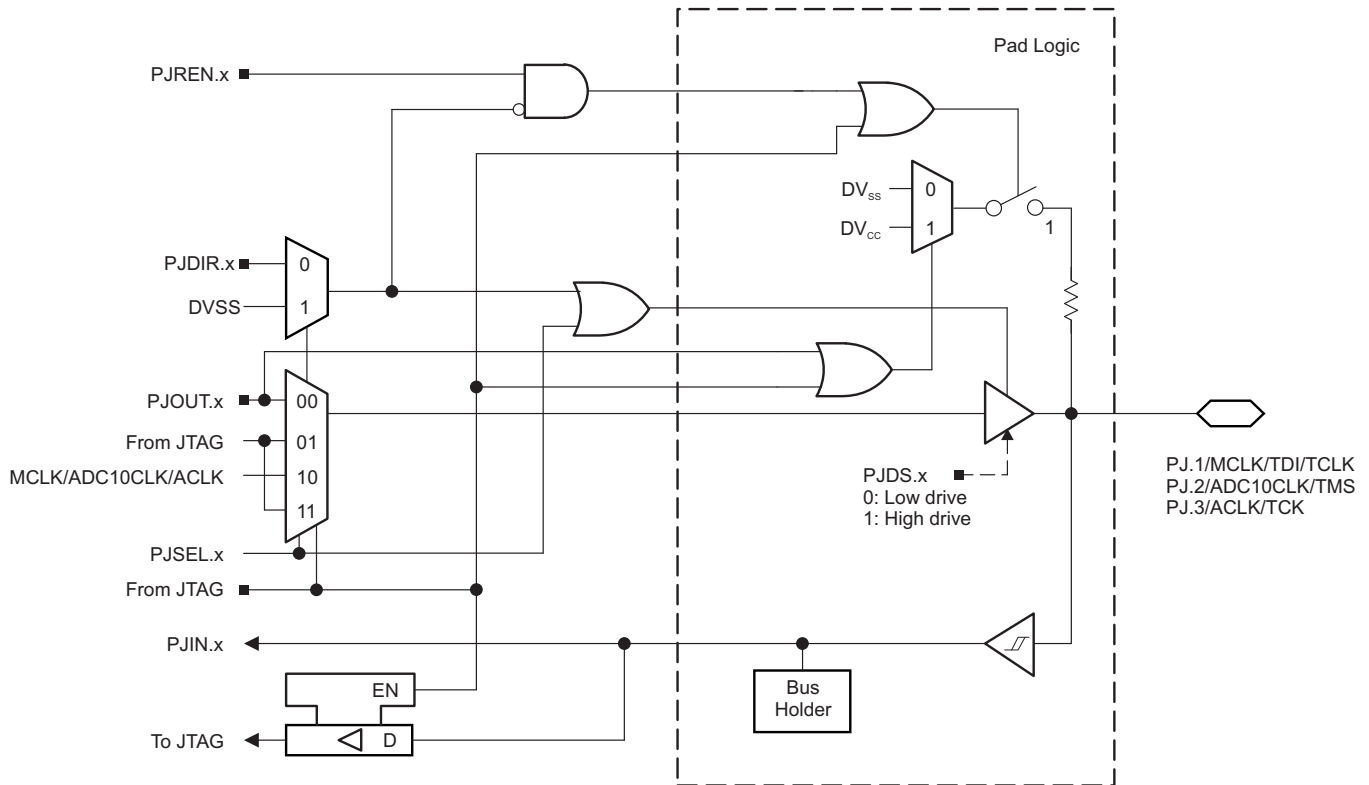

Figure 6-39. Port PJ (PJ.1 to PJ.3) Diagram

Table 6-97. Port PJ (PJ.0 to PJ.3) Pin Functions

PIN NAME (PJ.x)	x	FUNCTION	CONTROL BITS OR SIGNALS ⁽¹⁾		
			PJDIR.x	PJSEL.x	JTAG MODE
PJ.0/SMCLK/TDO	0	PJ.0 (I/O) ⁽²⁾	I: 0; O: 1	0	0
		SMCLK	1	1	0
		TDO ⁽³⁾	x	x	1
PJ.1/MCLK/TDI/TCLK	1	PJ.1 (I/O) ⁽²⁾	I: 0; O: 1	0	0
		MCLK	1	1	0
		TDI/TCLK ^{(3) (4)}	x	x	1
PJ.2/ADC10CLK/TMS	2	PJ.2 (I/O) ⁽²⁾	I: 0; O: 1	0	0
		ADC10CLK	1	1	0
		TMS ^{(3) (4)}	x	x	1
PJ.3/ACLK/TCK	3	PJ.3 (I/O) ⁽²⁾	I: 0; O: 1	0	0
		ACLK	1	1	0
		TCK ^{(3) (4)}	x	x	1

- (1) X = don't care
- (2) Default condition
- (3) The pin direction is controlled by the JTAG module.
- (4) In JTAG mode, pullups are activated automatically on TMS, TCK, and TDI/TCLK. PJREN.x are don't care.

6.15 Device Descriptors (TLV)

Table 6-98 lists the device descriptors for the MSP430F677x devices.

Table 6-98. MSP430F677x Device Descriptors

DESCRIPTION	ADDRESS	SIZE (BYTES)	VALUE					
			F6779IPEU F6779IPZ	F6778IPEU F6778IPZ	F6777IPEU F6777IPZ	F6776IPEU F6776IPZ	F6775IPEU F6775IPZ	
Info Block	Info length	1A00h	1	06h	06h	06h	06h	06h
	CRC length	1A01h	1	06h	06h	06h	06h	06h
	CRC value	1A02h	2	Per unit	Per unit	Per unit	Per unit	Per unit
	Device ID	1A04h	2	8196h	8195h	8194h	8193h	8192h
	Hardware revision	1A06h	1	Per unit	Per unit	Per unit	Per unit	Per unit
	Firmware revision	1A07h	1	Per unit	Per unit	Per unit	Per unit	Per unit
Die Record	Die record tag	1A08h	1	08h	08h	08h	08h	08h
	Die record length	1A09h	1	0Ah	0Ah	0Ah	0Ah	0Ah
	Lot ID	1A0Ah	4	Per unit	Per unit	Per unit	Per unit	Per unit
	X position	1A0Eh	2	Per unit	Per unit	Per unit	Per unit	Per unit
	Y position	1A10h	2	Per unit	Per unit	Per unit	Per unit	Per unit
	Test record CP	1A12h	1	Per unit	Per unit	Per unit	Per unit	Per unit
	Test record FT	1A13h	1	Per unit	Per unit	Per unit	Per unit	Per unit
ADC10 Calibration	ADC calibration tag	1A14h	1	13h	13h	13h	13h	13h
	ADC calibration length	1A15h	1	10h	10h	10h	10h	10h
	ADC gain factor	1A16h	2	Per unit	Per unit	Per unit	Per unit	Per unit
	ADC offset	1A18h	2	Per unit	Per unit	Per unit	Per unit	Per unit
	ADC 15T30	1A1Ah	2	Per unit	Per unit	Per unit	Per unit	Per unit
	ADC 15T85	1A1Ch	2	Per unit	Per unit	Per unit	Per unit	Per unit
	ADC 20T30	1A1Eh	2	Per unit	Per unit	Per unit	Per unit	Per unit
	ADC 20T85	1A20h	2	Per unit	Per unit	Per unit	Per unit	Per unit
	ADC 25T30	1A22h	2	Per unit	Per unit	Per unit	Per unit	Per unit
ADC 25T85	1A24h	2	Per unit	Per unit	Per unit	Per unit	Per unit	

Table 6-99 lists the device descriptors for the MSP430F676x devices.

Table 6-99. MSP430F676x Device Descriptors

DESCRIPTION	ADDRESS	SIZE (BYTES)	VALUE					
			F6769IPEU F6769IPZ	F6768IPEU F6768IPZ	F6767IPEU F6767IPZ	F6766IPEU F6766IPZ	F6765IPEU F6765IPZ	
Info Block	Info length	1A00h	1	06h	06h	06h	06h	06h
	CRC length	1A01h	1	06h	06h	06h	06h	06h
	CRC value	1A02h	2	Per unit	Per unit	Per unit	Per unit	Per unit
	Device ID	1A04h	2	8191h	8190h	818Fh	818Eh	818Dh
	Hardware revision	1A06h	1	Per unit	Per unit	Per unit	Per unit	Per unit
	Firmware revision	1A07h	1	Per unit	Per unit	Per unit	Per unit	Per unit
Die Record	Die record tag	1A08h	1	08h	08h	08h	08h	08h
	Die record length	1A09h	1	0Ah	0Ah	0Ah	0Ah	0Ah
	Lot ID	1A0Ah	4	Per unit	Per unit	Per unit	Per unit	Per unit
	X position	1A0Eh	2	Per unit	Per unit	Per unit	Per unit	Per unit
	Y position	1A10h	2	Per unit	Per unit	Per unit	Per unit	Per unit
	Test record CP	1A12h	1	Per unit	Per unit	Per unit	Per unit	Per unit
	Test record FT	1A13h	1	Per unit	Per unit	Per unit	Per unit	Per unit
ADC10 Calibration	ADC calibration tag	1A14h	1	13h	13h	13h	13h	13h
	ADC calibration length	1A15h	1	10h	10h	10h	10h	10h
	ADC gain factor	1A16h	2	Per unit	Per unit	Per unit	Per unit	Per unit
	ADC offset	1A18h	2	Per unit	Per unit	Per unit	Per unit	Per unit
	ADC 15T30	1A1Ah	2	Per unit	Per unit	Per unit	Per unit	Per unit
	ADC 15T85	1A1Ch	2	Per unit	Per unit	Per unit	Per unit	Per unit
	ADC 20T30	1A1Eh	2	Per unit	Per unit	Per unit	Per unit	Per unit
	ADC 20T85	1A20h	2	Per unit	Per unit	Per unit	Per unit	Per unit
	ADC 25T30	1A22h	2	Per unit	Per unit	Per unit	Per unit	Per unit
ADC 25T85	1A24h	2	Per unit	Per unit	Per unit	Per unit	Per unit	

Table 6-100 lists the device descriptors for the MSP430F674x devices.

Table 6-100. MSP430F674x Device Descriptor Table

DESCRIPTION	ADDRESS	SIZE (BYTES)	VALUE					
			F6749IPEU F6749IPZ	F6748IPEU F6748IPZ	F6747IPEU F6747IPZ	F6746IPEU F6746IPZ	F6745IPEU F6745IPZ	
Info Block	Info length	1A00h	1	06h	06h	06h	06h	06h
	CRC length	1A01h	1	06h	06h	06h	06h	06h
	CRC value	1A02h	2	Per unit	Per unit	Per unit	Per unit	Per unit
	Device ID	1A04h	2	818Ch	818Bh	818Ah	8189h	8188h
	Hardware revision	1A06h	1	Per unit	Per unit	Per unit	Per unit	Per unit
	Firmware revision	1A07h	1	Per unit	Per unit	Per unit	Per unit	Per unit
Die Record	Die record tag	1A08h	1	08h	08h	08h	08h	08h
	Die record length	1A09h	1	0Ah	0Ah	0Ah	0Ah	0Ah
	Lot ID	1A0Ah	4	Per unit	Per unit	Per unit	Per unit	Per unit
	X position	1A0Eh	2	Per unit	Per unit	Per unit	Per unit	Per unit
	Y position	1A10h	2	Per unit	Per unit	Per unit	Per unit	Per unit
	Test record CP	1A12h	1	Per unit	Per unit	Per unit	Per unit	Per unit
	Test record FT	1A13h	1	Per unit	Per unit	Per unit	Per unit	Per unit
ADC10 Calibration	ADC calibration tag	1A14h	1	13h	13h	13h	13h	13h
	ADC calibration length	1A15h	1	10h	10h	10h	10h	10h
	ADC gain factor	1A16h	2	Per unit	Per unit	Per unit	Per unit	Per unit
	ADC offset	1A18h	2	Per unit	Per unit	Per unit	Per unit	Per unit
	ADC 15T30	1A1Ah	2	Per unit	Per unit	Per unit	Per unit	Per unit
	ADC 15T85	1A1Ch	2	Per unit	Per unit	Per unit	Per unit	Per unit
	ADC 20T30	1A1Eh	2	Per unit	Per unit	Per unit	Per unit	Per unit
	ADC 20T85	1A20h	2	Per unit	Per unit	Per unit	Per unit	Per unit
	ADC 25T30	1A22h	2	Per unit	Per unit	Per unit	Per unit	Per unit
ADC 25T85	1A24h	2	Per unit	Per unit	Per unit	Per unit	Per unit	

7 デバイスおよびドキュメントのサポート

7.1 使い始めと次の手順

MSP430™ファミリのデバイス、および開発に役立つツールやライブラリの詳細については、「[Getting Started](#)」ページを参照してください。

7.2 Device Nomenclature

To designate the stages in the product development cycle, TI assigns prefixes to the part numbers of all MSP MCU devices. Each MSP MCU commercial family member has one of two prefixes: MSP or XMS. These prefixes represent evolutionary stages of product development from engineering prototypes (XMS) through fully qualified production devices (MSP).

XMS – Experimental device that is not necessarily representative of the final device's electrical specifications

MSP – Fully qualified production device

XMS devices are shipped against the following disclaimer:

"Developmental product is intended for internal evaluation purposes."

MSP devices have been characterized fully, and the quality and reliability of the device have been demonstrated fully. TI's standard warranty applies.

Predictions show that prototype devices (XMS) have a greater failure rate than the standard production devices. TI recommends that these devices not be used in any production system because their expected end-use failure rate still is undefined. Only qualified production devices are to be used.

TI device nomenclature also includes a suffix with the device family name. This suffix indicates the temperature range, package type, and distribution format. [Figure 7-1](#) provides a legend for reading the complete device name.

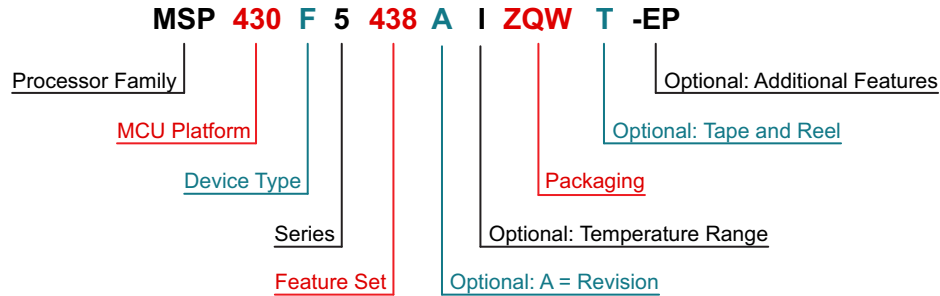

Processor Family	CC = Embedded RF Radio MSP = Mixed-Signal Processor XMS = Experimental Silicon PMS = Prototype Device	
MCU Platform	430 = MSP430 low-power microcontroller platform	
Device Type	Memory Type C = ROM F = Flash FR = FRAM G = Flash or FRAM (Value Line) L = No Nonvolatile Memory	Specialized Application AFE = Analog Front End BQ = Contactless Power CG = ROM Medical FE = Flash Energy Meter FG = Flash Medical FW = Flash Electronic Flow Meter
Series	1 = Up to 8 MHz 2 = Up to 16 MHz 3 = Legacy 4 = Up to 16 MHz with LCD	5 = Up to 25 MHz 6 = Up to 25 MHz with LCD 0 = Low-Voltage Series
Feature Set	Various levels of integration within a series	
Optional: A = Revision	N/A	
Optional: Temperature Range	S = 0°C to 50°C C = 0°C to 70°C I = -40°C to 85°C T = -40°C to 105°C	
Packaging	http://www.ti.com/packaging	
Optional: Tape and Reel	T = Small reel R = Large reel No markings = Tube or tray	
Optional: Additional Features	-EP = Enhanced Product (-40°C to 105°C) -HT = Extreme Temperature Parts (-55°C to 150°C) -Q1 = Automotive Q100 Qualified	

☒ 7-1. Device Nomenclature

7.3 ツールとソフトウェア

すべてのMSPマイクロコントローラは、広範なソフトウェアおよびハードウェア開発ツールによりサポートされています。ツールは、TIおよびさまざまなサードパーティーから入手できます。詳細については、「[MSP430超低消費電力マイコン – ツールとソフトウェア](#)」を参照してください。

表 7-1にMSP430F677x、MSP430F676x、MSP430F674x MCUのデバッグ機能を示します。利用可能な機能の詳細については、『[MSP430用Code Composer Studio ユーザー・ガイド](#)』を参照してください。

表 7-1. ハードウェアのデバッグ機能

MSP430のアーキテクチャ	4線式JTAG	2線式JTAG	ブレーク・ポイント (N)	範囲ブレーク・ポイント	クロック制御	状態シーケンサ	トレース・バッファ	LPMx.5デバッグ・サポート
MSP430Xv2	○	○	3	○	○	×	×	○

設計キットと評価モジュール

EVM430-F6779 - 3相電子電力量計EVM EVM430-F6779は、MSP430F6779を使用した3相電力量計評価モジュールです。このEメータは3つの電圧と3つの電流に対応する入力を用意しており、追加接続により改ざん対策も設定できます。

MSP430F6x MCU用の128ピン・ターゲット開発ボードとMSP-FETプログラマ・バンドル MSP-FET430U128は強力なフラッシュ・エミュレーション・ツールで、MSP430 MCUによるアプリケーション開発をすぐに開始できます。USBデバッグ・インターフェイスにより、JTAGインターフェイスまたは省ピンSpy-Bi-Wire (2線式JTAG)プロトコルを使用してMSP430をインシステムでプログラミングおよびデバッグできます。

ソフトウェア

MSP430Ware™ソフトウェア MSP430Wareソフトウェアは、すべてのMSP430デバイス向けのサンプル・コード、データシート、その他の設計リソースを、1つの便利なパッケージとしてまとめたものです。既存のMSP430用設計リソースの完全なコレクションに加えて、MSP430WareソフトウェアにはMSPドライバ・ライブラリという高レベルのAPIも含まれています。このライブラリにより、MSP430ハードウェアを簡単にプログラムできます。MSP430WareソフトウェアはCCSのコンポーネントとして、またはスタンドアロンのパッケージとして入手できます。

MSP430マイコン向けエネルギー測定デザイン・センター エネルギー測定デザイン・センターは、TI MSP430i20xxおよびMSP430F67xxフラッシュ・ベース・マイクロコントローラ(MCU)を使用したエネルギー測定システムを短期間で開発できるツールです。グラフィカル・ユーザー・インターフェイス(GUI)、ドキュメント、ソフトウェア・ライブラリ、およびサンプルが含まれているため、スマート・グリッドやビルディング・オートメーションなどを含む、広範な電力監視およびエネルギー測定アプリケーションを簡単に開発でき、設計時間を短縮できます。デザイン・センターを利用すれば、コードを1行も書かずに構成や較正を行い、結果を確認できます。

IEC60730ソフトウェア・パッケージ IEC60730 MSP430ソフトウェア・パッケージは、クラスBまでの製品について、お客様がIEC 60730-1:2010 (家庭および同様な用途に使用される自動電気制御 – 第1部: 一般的な要件)に準拠するため役立つよう開発されています。この分類には家電機器、アーク検出器、電力コンバータ、電動工具、電動アシスト自転車、その他多くの製品が含まれます。IEC60730 MSP430ソフトウェア・パッケージは、MSP430で実行するお客様のアプリケーションに組み込むことができるため、消費者向けデバイスがIEC 60730-1:2010クラスBの機能安全性に準拠していることの認定作業を簡素化できます。

MSPドライバ・ライブラリ MSPドライバ・ライブラリの抽象化されたAPIには、使いやすい関数呼び出しが含まれているため、MSP430ハードウェアのビットやバイトを直接操作する煩雑さから解放されます。使いやすいAPIガイドにより包括的な技術資料が参照でき、それぞれの関数呼び出しと、認識されるパラメータの詳細が記載されています。開発者は、ドライバ・ライブラリの関数を使用して、最小限のオーバーヘッドで完全なプロジェクトを作成できます。

MSP430F677x(1)、MSP430F676x(1)、MSP430F674x(1)コード・サンプル すべてのMSPデバイス用に、内蔵の各ペリフェラルをさまざまなアプリケーションの要求に応じて構成するためのCコード・サンプルが用意されています。

静電容量式タッチ・ソフトウェア・ライブラリ MSP430 MCU で静電容量式タッチ機能を有効にするための、無償のCライブラリです。MSP430 MCU バージョンのライブラリには、ROおよびRC方式を含む、いくつかの静電容量式タッチ機能の実装が含まれています。

MSP EnergyTrace™テクノロジー MSP430マイクロコントローラ用のEnergyTraceテクノロジーは、エネルギーを基準としたコード解析ツールで、アプリケーションのエネルギー・プロファイルを測定して表示し、消費電力が極めて低くなるよう最適化するため役立ちます。

ULP (超低消費電力) Advisor ULP Advisor™ソフトウェアは、MSPおよびMSP432マイクロコントローラの超低消費電力機能を十分に活用できる、最も効率的なコードを開発者が作成できるよう手引きするツールです。ULP Advisorはマイクロコントローラに熟練した開発者と、新しい開発者の両方を対象としており、包括的なULPチェックリストを使用してコードをチェックし、アプリケーションのエネルギー消費を最小化するため役立ちます。ビルド時に、消費電力低減のためさらに最適化が可能なコードの部分を明らかにするため通知と注釈を出力します。

MSP用の固定小数点算術ライブラリ MSP IQmathおよびQmathライブラリは、Cプログラマ向けの高度に最適化された高精度の算術関数のコレクションで、浮動小数点アルゴリズムをMSP430およびMSP432デバイスの固定小数点コードへシームレスに移行できます。これらのルーチンは通常、最適な実行速度、高精度、超低消費電力が重視される、演算集中型のリアルタイム・アプリケーションで使用されます。IQmathライブラリとQmathライブラリを使用すると、浮動小数点演算を使用して記述した同等のコードに比べて、実行速度を大幅に高速化するとともに、消費電力の大幅な削減が可能です。

MSP430用の浮動小数点算術ライブラリ 低消費電力で低コストのマイクロコントローラ分野にさらなる革新を引き起こすため、TIはMSPMATHLIBを提供します。この浮動小数点算術ライブラリは、弊社デバイスのインテリジェントなペリフェラルを活用し、標準のMSP430算術関数よりも最高で26倍も高速なスカラ関数です。Mathlibは、設計へ簡単に組み入れることができます。このライブラリは無償で、Code Composer Studio IDEとIAR Embedded Workbench IDEの両方に組み込まれています。

開発ツール

Code Composer Studio™: MSPマイクロコントローラ用の統合開発環境 Code Composer Studio (CCS)は、すべてのMSPマイクロコントローラ・デバイスをサポートする統合開発環境(IDE)です。CCSは、組み込みアプリケーションの開発とデバッグに使用される、組み込み用ソフトウェア・ユーティリティのスイートです。最適化C/C++コンパイラ、ソース・コード・エディタ、プロジェクト・ビルド環境、デバッグ、プロファイラなど、多数の機能が含まれています。

コマンドライン・プログラマ MSP Flasher は、FETプログラマまたは eZ430 を経由し、JTAG または Spy-Bi-Wire (SBW) 通信を使用して MSP マイクロコントローラをプログラムするための、オープン・ソースでシェル・ベースのインターフェイスです。MSP Flasher は、IDE を使用せずにバイナリ・ファイル (.txt または .hex) を MSP マイクロコントローラへ直接ダウンロードできます。

MSP MCUプログラマおよびデバッグ MSP-FETは強力なエミュレーション開発ツールで、多くの場合にデバッグ・プローブと呼ばれます。ユーザーはこのツールを使用して、MSP低消費電力MCUのアプリケーション開発をすぐに始めることができます。MCUのソフトウェアを作成する場合は通常、結果として得られたバイナリ・プログラムをMSPデバイスにダウンロードし、検証とデバッグを行う必要があります。

MSP-GANG量産プログラマ MSP Gang プログラマは MSP430 または MSP432 用のデバイス・プログラマで、8 つまでの同一の MSP430 または MSP432 のフラッシュまたは FRAM デバイスを同時にプログラムできます。MSP Gang プログラマは、標準の RS-232 または USB 接続を使用してホスト PC と接続し、柔軟なプログラミング・オプションが用意されているため、ユーザーはプロセスを完全にカスタマイズ可能です。

7.4 ドキュメントのサポート

以下のドキュメントはMSP430F677x、MSP430F676x、MSP430F674x MCUについて記載したものです。これらのドキュメントのコピーは、www.ti.comで入手できます。

ドキュメントの更新通知を受け取る方法

ドキュメント更新の通知を、シリコンの正誤表も含めて受け取るには、ti.comでお使いの製品のフォルダへ移動します(プロダクト・フォルダへのリンクについては、[7.5](#)を参照してください)。右上の隅にある「通知を受け取る」ボタンをクリックします。これによって登録が行われ、変更された製品情報の概要を毎週受け取ることができます。変更の詳細については、修正されたドキュメントに含まれている改訂履歴をご覧ください。

正誤表

『[MSP430F6779デバイス正誤表](#)』には、機能仕様に対する既知の例外が記載されています。

『[MSP430F6778デバイス正誤表](#)』には、機能仕様に対する既知の例外が記載されています。

『[MSP430F6777デバイス正誤表](#)』には、機能仕様に対する既知の例外が記載されています。

『[MSP430F6776デバイス正誤表](#)』には、機能仕様に対する既知の例外が記載されています。

『[MSP430F6775デバイス正誤表](#)』には、機能仕様に対する既知の例外が記載されています。

『[MSP430F6769デバイス正誤表](#)』には、機能仕様に対する既知の例外が記載されています。

『[MSP430F6768デバイス正誤表](#)』には、機能仕様に対する既知の例外が記載されています。

『[MSP430F6767デバイス正誤表](#)』には、機能仕様に対する既知の例外が記載されています。

『[MSP430F6766デバイス正誤表](#)』には、機能仕様に対する既知の例外が記載されています。

『[MSP430F6765デバイス正誤表](#)』には、機能仕様に対する既知の例外が記載されています。

『[MSP430F6749デバイス正誤表](#)』には、機能仕様に対する既知の例外が記載されています。

『[MSP430F6748デバイス正誤表](#)』には、機能仕様に対する既知の例外が記載されています。

『[MSP430F6747デバイス正誤表](#)』には、機能仕様に対する既知の例外が記載されています。

『[MSP430F6746デバイス正誤表](#)』には、機能仕様に対する既知の例外が記載されています。

『[MSP430F6745デバイス正誤表](#)』には、機能仕様に対する既知の例外が記載されています。

ユーザー・ガイド

『[MSP430x5xxおよびMSP430x6xxファミリ・ユーザー・ガイド](#)』 このデバイス・ファミリで利用可能なモジュールとペリフェラルについての詳細情報です。

『[MSP430™ フラッシュ・デバイス・ブートローダ\(BSL\)ユーザー・ガイド](#)』 MSP430ブートローダ(BSL) (旧ブートストラップ・ローダ)を使用すると、プロトタイプ作成、最終的な量産、および使用時に、MSP430マイクロコントローラの組み込みメモリと通信を行うことができます。必要に応じて、プログラム可能メモリ(フラッシュ・メモリ)とデータ・メモリ(RAM)の両方を変更できます。このブートローダは、一部のデジタル・シグナル・プロセッサ(DSP)に見られる、外部メモリからDSPの内部メモリへプログラム・コード(およびデータを)自動的にロードする、ブートストラップ・ローダ・プログラムとは異なることに注意してください。

『[JTAGインターフェイスによるMSP430のプログラミング](#)』 このドキュメントでは、JTAG通信ポートを使用してMSP430のフラッシュ・ベースおよびFRAMベースのマイクロコントローラ・ファミリのメモリ・モジュールを消去、プログラム、検証するために必要な機能について解説しています。さらに、すべてのMSP430デバイスで利用可能なJTAGアクセス・セキュリティ・ヒューズのプログラム方法についても解説しています。このドキュメントには、標準の4線式JTAGインターフェイスと2線式JTAGインターフェイスの両方を使用してデバイスにアクセスする方法が解説されています。2線式JTAGインターフェイスはSpy-Bi-Wire (SBW)とも呼ばれます。

『[MSP430ハードウェア・ツール ユーザー・ガイド](#)』 このマニュアルには、TI MSP-FET430フラッシュ・エミュレーション・ツール(FET)のハードウェアについて解説されています。このFETは、MSP430 超低消費電力マイクロコントローラ用のプログラム開発ツールです。利用可能なインターフェイスとして、パラレル・ポート・インターフェイスとUSBインターフェイスの両方について解説されています。

アプリケーション・レポート

- 『**MSP430F677x(A)**を使用した**3相電子電力量計の実装**』 このアプリケーション・レポートでは、テキサス・インスツルメンツMSP430F677x(A)メータリング・プロセッサを使用した3相電子電力量計の実装について解説します。このシングルチップ実装向けの計量ソフトウェアやハードウェア手順について必要な情報が記載されています。
- 『**TIのDLMS COSEMライブラリの使用**』 このアプリケーション・レポートでは、TIのマイクロコントローラによる計量機器開発を支援するためにテキサス・インスツルメンツが開発したDLMS COSEMライブラリの使用方法を詳しく解説します。このライブラリは、使いやすいオブジェクト・コードと構成ファイルからなり、各販売代理店を通じて入手できます。
- 『**MSP430F67xxデバイスとMSP430F67xxAデバイスの違い**』 このアプリケーション・レポートでは、Aの付かないMSP430F67xxから進化したMSP430F67xxAの機能強化について解説します。MSP430F67xxAで修正されたMSP430F67xxの正誤表と、MSP430F67xxAに追加された機能について説明するほか、計量結果を比較して、MSP430F67xxAでの変更点が計量性能に影響を与えないことも示しています。
- 『**MSP430 32kHz水晶発振器**』 適切な水晶振動子、正しい負荷回路、および適切な基板レイアウトの選択は、安定した水晶発振器に重要です。このアプリケーション・レポートでは、水晶発振器の機能について要約し、MSP430の超低消費電力動作の適切な水晶を選択するためのパラメータについて説明します。また、正しい基板レイアウトについてのヒントや例も紹介しています。このドキュメントには、量産時の安定した発振器の動作を保証するために行うことができる、発振器のテストについての詳細情報も記載されています。
- 『**MSP430 システム・レベルESDの考慮事項**』 シリコン・テクノロジーがますます低電圧化し、コスト効率に優れ非常に消費電力の低いコンポーネントを設計する必要性が高まっていくにつれ、システム・レベルESDの要求はますます高くなりつつあります。このアプリケーション・レポートでは、基板設計者とOEMが堅牢なシステム・レベルのデザインを理解し設計できるよう、3種類の異なるESDトピックについて扱います。
- 『**MSP430とセグメントLCDを使用する設計**』 セグメント液晶ディスプレイ(LCD)は、スマート・メーターから電子棚札(ESL)、医療機器に至る広範なアプリケーションで、ユーザーに情報を提供するために必要です。MSP430™マイクロコントローラ・ファミリの中には、低電力のLCDドライバ回路を内蔵し、MSP430 MCUでセグメントLCDガラスを直接制御できるものもあります。このアプリケーション・ノートは以下の項目の補助的な説明を記載しています。セグメントLCDの動作、MSP430 MCUファミリにおける各種LCDモジュールの様々な機能、LCDハードウェアをレイアウトするコツ、効率的で使いやすいLCDドライバ・ソフトウェアの書き方のガイド、デバイス選択に役立つ、様々なLCD機能を含んだMSP430デバイスの製品ラインの概要。

7.5 関連リンク

表 7-2 に、クイック・アクセス・リンクの一覧を示します。カテゴリには、技術資料、サポートおよびコミュニティ・リソース、ツールとソフトウェア、およびサンプル注文またはご購入へのクイック・アクセスが含まれます。

表 7-2. 関連リンク

製品	プロダクト・フォルダ	ご注文はこちら	技術資料	ツールとソフトウェア	サポートとコミュニティ
MSP430F6779	ここをクリック	ここをクリック	ここをクリック	ここをクリック	ここをクリック
MSP430F6778	ここをクリック	ここをクリック	ここをクリック	ここをクリック	ここをクリック
MSP430F6777	ここをクリック	ここをクリック	ここをクリック	ここをクリック	ここをクリック
MSP430F6776	ここをクリック	ここをクリック	ここをクリック	ここをクリック	ここをクリック
MSP430F6775	ここをクリック	ここをクリック	ここをクリック	ここをクリック	ここをクリック
MSP430F6769	ここをクリック	ここをクリック	ここをクリック	ここをクリック	ここをクリック
MSP430F6768	ここをクリック	ここをクリック	ここをクリック	ここをクリック	ここをクリック
MSP430F6767	ここをクリック	ここをクリック	ここをクリック	ここをクリック	ここをクリック
MSP430F6766	ここをクリック	ここをクリック	ここをクリック	ここをクリック	ここをクリック
MSP430F6765	ここをクリック	ここをクリック	ここをクリック	ここをクリック	ここをクリック
MSP430F6749	ここをクリック	ここをクリック	ここをクリック	ここをクリック	ここをクリック
MSP430F6748	ここをクリック	ここをクリック	ここをクリック	ここをクリック	ここをクリック
MSP430F6747	ここをクリック	ここをクリック	ここをクリック	ここをクリック	ここをクリック
MSP430F6746	ここをクリック	ここをクリック	ここをクリック	ここをクリック	ここをクリック
MSP430F6745	ここをクリック	ここをクリック	ここをクリック	ここをクリック	ここをクリック

7.6 Community Resources

The following links connect to TI community resources. Linked contents are provided "AS IS" by the respective contributors. They do not constitute TI specifications and do not necessarily reflect TI's views; see TI's [Terms of Use](#).

[TI E2E™ Community](#)

TI's *Engineer-to-Engineer (E2E) Community*. Created to foster collaboration among engineers. At e2e.ti.com, you can ask questions, share knowledge, explore ideas, and help solve problems with fellow engineers.

[TI Embedded Processors Wiki](#)

Texas Instruments Embedded Processors Wiki. Established to help developers get started with embedded processors from Texas Instruments and to foster innovation and growth of general knowledge about the hardware and software surrounding these devices.

7.7 商標

MSP430, MSP430Ware, EnergyTrace, ULP Advisor, Code Composer Studio, E2E are trademarks of Texas Instruments.

All other trademarks are the property of their respective owners.

7.8 静電気放電に関する注意事項



すべての集積回路は、適切なESD保護方法を用いて、取扱いと保存を行うようにして下さい。

静電気放電はわずかな性能の低下から完全なデバイスの故障に至るまで、様々な損傷を与えます。高精度の集積回路は、損傷に対して敏感であり、極めてわずかなパラメータの変化により、デバイスに規定された仕様に適合しなくなる場合があります。

7.9 Export Control Notice

Recipient agrees to not knowingly export or re-export, directly or indirectly, any product or technical data (as defined by the U.S., EU, and other Export Administration Regulations) including software, or any controlled product restricted by other applicable national regulations, received from disclosing party under nondisclosure obligations (if any), or any direct product of such technology, to any destination to which such export or re-export is restricted or prohibited by U.S. or other applicable laws, without obtaining prior authorization from U.S. Department of Commerce and other competent Government authorities to the extent required by those laws.

7.10 Glossary

TI Glossary This glossary lists and explains terms, acronyms, and definitions.

8 メカニカル、パッケージ、および注文情報

以降のページには、メカニカル、パッケージ、および注文に関する情報が記載されています。これらの情報は、指定のデバイスに対して提供されている最新のデータです。このデータは予告なく変更されることがあり、ドキュメントが改訂される場合もあります。本データシートのブラウザ版を使用されている場合は、画面左側の説明をご覧ください。

PACKAGING INFORMATION

Orderable part number	Status (1)	Material type (2)	Package Pins	Package qty Carrier	RoHS (3)	Lead finish/ Ball material (4)	MSL rating/ Peak reflow (5)	Op temp (°C)	Part marking (6)
MSP430F6745IPEU	Active	Production	LQFP (PEU) 128	72 JEDEC TRAY (10+1)	Yes	NIPDAU	Level-3-260C-168 HR	-40 to 85	F6745
MSP430F6745IPEU.B	Active	Production	LQFP (PEU) 128	72 JEDEC TRAY (10+1)	Yes	NIPDAU	Level-3-260C-168 HR	-40 to 85	F6745
MSP430F6745IPZ	Active	Production	LQFP (PZ) 100	90 JEDEC TRAY (10+1)	Yes	NIPDAU	Level-3-260C-168 HR	-40 to 85	F6745
MSP430F6745IPZ.B	Active	Production	LQFP (PZ) 100	90 JEDEC TRAY (10+1)	Yes	NIPDAU	Level-3-260C-168 HR	-40 to 85	F6745
MSP430F6746IPEU	Active	Production	LQFP (PEU) 128	72 JEDEC TRAY (10+1)	Yes	NIPDAU	Level-3-260C-168 HR	-40 to 85	F6746
MSP430F6746IPEU.B	Active	Production	LQFP (PEU) 128	72 JEDEC TRAY (10+1)	Yes	NIPDAU	Level-3-260C-168 HR	-40 to 85	F6746
MSP430F6746IPZ	Active	Production	LQFP (PZ) 100	90 JEDEC TRAY (10+1)	Yes	NIPDAU	Level-3-260C-168 HR	-40 to 85	F6746
MSP430F6746IPZ.B	Active	Production	LQFP (PZ) 100	90 JEDEC TRAY (10+1)	Yes	NIPDAU	Level-3-260C-168 HR	-40 to 85	F6746
MSP430F6747IPEU	Active	Production	LQFP (PEU) 128	72 JEDEC TRAY (10+1)	Yes	NIPDAU	Level-3-260C-168 HR	-40 to 85	F6747
MSP430F6747IPEU.B	Active	Production	LQFP (PEU) 128	72 JEDEC TRAY (10+1)	Yes	NIPDAU	Level-3-260C-168 HR	-40 to 85	F6747
MSP430F6747IPZ	Active	Production	LQFP (PZ) 100	90 JEDEC TRAY (10+1)	Yes	NIPDAU	Level-3-260C-168 HR	-40 to 85	F6747
MSP430F6747IPZ.B	Active	Production	LQFP (PZ) 100	90 JEDEC TRAY (10+1)	Yes	NIPDAU	Level-3-260C-168 HR	-40 to 85	F6747
MSP430F6747IPZR	Active	Production	LQFP (PZ) 100	1000 LARGE T&R	Yes	NIPDAU	Level-3-260C-168 HR	-40 to 85	F6747
MSP430F6747IPZR.B	Active	Production	LQFP (PZ) 100	1000 LARGE T&R	Yes	NIPDAU	Level-3-260C-168 HR	-40 to 85	F6747
MSP430F6748IPEU	Active	Production	LQFP (PEU) 128	72 JEDEC TRAY (10+1)	Yes	NIPDAU	Level-3-260C-168 HR	-40 to 85	F6748
MSP430F6748IPEU.B	Active	Production	LQFP (PEU) 128	72 JEDEC TRAY (10+1)	Yes	NIPDAU	Level-3-260C-168 HR	-40 to 85	F6748
MSP430F6748IPZ	Active	Production	LQFP (PZ) 100	90 JEDEC TRAY (10+1)	Yes	NIPDAU	Level-3-260C-168 HR	-40 to 85	F6748

Orderable part number	Status (1)	Material type (2)	Package Pins	Package qty Carrier	RoHS (3)	Lead finish/ Ball material (4)	MSL rating/ Peak reflow (5)	Op temp (°C)	Part marking (6)
MSP430F6748IPZ.B	Active	Production	LQFP (PZ) 100	90 JEDEC TRAY (10+1)	Yes	NIPDAU	Level-3-260C-168 HR	-40 to 85	F6748
MSP430F6749IPEU	Active	Production	LQFP (PEU) 128	72 JEDEC TRAY (10+1)	Yes	NIPDAU	Level-3-260C-168 HR	-40 to 85	F6749
MSP430F6749IPEU.B	Active	Production	LQFP (PEU) 128	72 JEDEC TRAY (10+1)	Yes	NIPDAU	Level-3-260C-168 HR	-40 to 85	F6749
MSP430F6749IPZ	Active	Production	LQFP (PZ) 100	90 JEDEC TRAY (10+1)	Yes	NIPDAU	Level-3-260C-168 HR	-40 to 85	F6749
MSP430F6749IPZ.B	Active	Production	LQFP (PZ) 100	90 JEDEC TRAY (10+1)	Yes	NIPDAU	Level-3-260C-168 HR	-40 to 85	F6749
MSP430F6765IPEU	Active	Production	LQFP (PEU) 128	72 JEDEC TRAY (10+1)	Yes	NIPDAU	Level-3-260C-168 HR	-40 to 85	F6765
MSP430F6765IPEU.B	Active	Production	LQFP (PEU) 128	72 JEDEC TRAY (10+1)	Yes	NIPDAU	Level-3-260C-168 HR	-40 to 85	F6765
MSP430F6765IPZ	Active	Production	LQFP (PZ) 100	90 JEDEC TRAY (10+1)	Yes	NIPDAU	Level-3-260C-168 HR	-40 to 85	F6765
MSP430F6765IPZ.B	Active	Production	LQFP (PZ) 100	90 JEDEC TRAY (10+1)	Yes	NIPDAU	Level-3-260C-168 HR	-40 to 85	F6765
MSP430F6765IPZR	Active	Production	LQFP (PZ) 100	1000 LARGE T&R	Yes	NIPDAU	Level-3-260C-168 HR	-40 to 85	F6765
MSP430F6765IPZR.B	Active	Production	LQFP (PZ) 100	1000 LARGE T&R	Yes	NIPDAU	Level-3-260C-168 HR	-40 to 85	F6765
MSP430F6766IPEU	Active	Production	LQFP (PEU) 128	72 JEDEC TRAY (10+1)	Yes	NIPDAU	Level-3-260C-168 HR	-40 to 85	F6766
MSP430F6766IPEU.B	Active	Production	LQFP (PEU) 128	72 JEDEC TRAY (10+1)	Yes	NIPDAU	Level-3-260C-168 HR	-40 to 85	F6766
MSP430F6766IPZ	Active	Production	LQFP (PZ) 100	90 JEDEC TRAY (10+1)	Yes	NIPDAU	Level-3-260C-168 HR	-40 to 85	F6766
MSP430F6766IPZ.B	Active	Production	LQFP (PZ) 100	90 JEDEC TRAY (10+1)	Yes	NIPDAU	Level-3-260C-168 HR	-40 to 85	F6766
MSP430F6767IPEU	Active	Production	LQFP (PEU) 128	72 JEDEC TRAY (10+1)	Yes	NIPDAU	Level-3-260C-168 HR	-40 to 85	F6767
MSP430F6767IPEU.B	Active	Production	LQFP (PEU) 128	72 JEDEC TRAY (10+1)	Yes	NIPDAU	Level-3-260C-168 HR	-40 to 85	F6767
MSP430F6767IPZ	Active	Production	LQFP (PZ) 100	90 JEDEC TRAY (10+1)	Yes	NIPDAU	Level-3-260C-168 HR	-40 to 85	F6767

Orderable part number	Status (1)	Material type (2)	Package Pins	Package qty Carrier	RoHS (3)	Lead finish/ Ball material (4)	MSL rating/ Peak reflow (5)	Op temp (°C)	Part marking (6)
MSP430F6767IPZ.B	Active	Production	LQFP (PZ) 100	90 JEDEC TRAY (10+1)	Yes	NIPDAU	Level-3-260C-168 HR	-40 to 85	F6767
MSP430F6768IPEU	Active	Production	LQFP (PEU) 128	72 JEDEC TRAY (10+1)	Yes	NIPDAU	Level-3-260C-168 HR	-40 to 85	F6768
MSP430F6768IPEU.B	Active	Production	LQFP (PEU) 128	72 JEDEC TRAY (10+1)	Yes	NIPDAU	Level-3-260C-168 HR	-40 to 85	F6768
MSP430F6768IPZ	Active	Production	LQFP (PZ) 100	90 JEDEC TRAY (10+1)	Yes	NIPDAU	Level-3-260C-168 HR	-40 to 85	F6768
MSP430F6768IPZ.B	Active	Production	LQFP (PZ) 100	90 JEDEC TRAY (10+1)	Yes	NIPDAU	Level-3-260C-168 HR	-40 to 85	F6768
MSP430F6769IPEU	Active	Production	LQFP (PEU) 128	72 JEDEC TRAY (10+1)	Yes	NIPDAU	Level-3-260C-168 HR	-40 to 85	F6769
MSP430F6769IPEU.B	Active	Production	LQFP (PEU) 128	72 JEDEC TRAY (10+1)	Yes	NIPDAU	Level-3-260C-168 HR	-40 to 85	F6769
MSP430F6769IPZ	Active	Production	LQFP (PZ) 100	90 JEDEC TRAY (10+1)	Yes	NIPDAU	Level-3-260C-168 HR	-40 to 85	F6769
MSP430F6769IPZ.B	Active	Production	LQFP (PZ) 100	90 JEDEC TRAY (10+1)	Yes	NIPDAU	Level-3-260C-168 HR	-40 to 85	F6769
MSP430F6775IPEU	Active	Production	LQFP (PEU) 128	72 JEDEC TRAY (10+1)	Yes	NIPDAU	Level-3-260C-168 HR	-40 to 85	F6775
MSP430F6775IPEU.B	Active	Production	LQFP (PEU) 128	72 JEDEC TRAY (10+1)	Yes	NIPDAU	Level-3-260C-168 HR	-40 to 85	F6775
MSP430F6775IPZ	Active	Production	LQFP (PZ) 100	90 JEDEC TRAY (10+1)	Yes	NIPDAU	Level-3-260C-168 HR	-40 to 85	F6775
MSP430F6775IPZ.B	Active	Production	LQFP (PZ) 100	90 JEDEC TRAY (10+1)	Yes	NIPDAU	Level-3-260C-168 HR	-40 to 85	F6775
MSP430F6775IPZR	Active	Production	LQFP (PZ) 100	1000 LARGE T&R	Yes	NIPDAU	Level-3-260C-168 HR	-40 to 85	F6775
MSP430F6775IPZR.B	Active	Production	LQFP (PZ) 100	1000 LARGE T&R	Yes	NIPDAU	Level-3-260C-168 HR	-40 to 85	F6775
MSP430F6776IPEU	Active	Production	LQFP (PEU) 128	72 JEDEC TRAY (10+1)	Yes	NIPDAU	Level-3-260C-168 HR	-40 to 85	F6776
MSP430F6776IPEU.B	Active	Production	LQFP (PEU) 128	72 JEDEC TRAY (10+1)	Yes	NIPDAU	Level-3-260C-168 HR	-40 to 85	F6776
MSP430F6776IPEUR	Active	Production	LQFP (PEU) 128	750 LARGE T&R	Yes	NIPDAU	Level-3-260C-168 HR	-40 to 85	F6776
MSP430F6776IPEUR.B	Active	Production	LQFP (PEU) 128	750 LARGE T&R	Yes	NIPDAU	Level-3-260C-168 HR	-40 to 85	F6776

Orderable part number	Status (1)	Material type (2)	Package Pins	Package qty Carrier	RoHS (3)	Lead finish/ Ball material (4)	MSL rating/ Peak reflow (5)	Op temp (°C)	Part marking (6)
MSP430F6776IPZ	Active	Production	LQFP (PZ) 100	90 JEDEC TRAY (10+1)	Yes	NIPDAU	Level-3-260C-168 HR	-40 to 85	F6776
MSP430F6776IPZ.B	Active	Production	LQFP (PZ) 100	90 JEDEC TRAY (10+1)	Yes	NIPDAU	Level-3-260C-168 HR	-40 to 85	F6776
MSP430F6777IPEU	Active	Production	LQFP (PEU) 128	72 JEDEC TRAY (10+1)	Yes	NIPDAU	Level-3-260C-168 HR	-40 to 85	F6777
MSP430F6777IPEU.B	Active	Production	LQFP (PEU) 128	72 JEDEC TRAY (10+1)	Yes	NIPDAU	Level-3-260C-168 HR	-40 to 85	F6777
MSP430F6777IPEUR	Active	Production	LQFP (PEU) 128	750 LARGE T&R	Yes	NIPDAU	Level-3-260C-168 HR	-40 to 85	F6777
MSP430F6777IPEUR.B	Active	Production	LQFP (PEU) 128	750 LARGE T&R	Yes	NIPDAU	Level-3-260C-168 HR	-40 to 85	F6777
MSP430F6777IPZ	Active	Production	LQFP (PZ) 100	90 JEDEC TRAY (10+1)	Yes	NIPDAU	Level-3-260C-168 HR	-40 to 85	F6777
MSP430F6777IPZ.B	Active	Production	LQFP (PZ) 100	90 JEDEC TRAY (10+1)	Yes	NIPDAU	Level-3-260C-168 HR	-40 to 85	F6777
MSP430F6777IPZR	Active	Production	LQFP (PZ) 100	1000 LARGE T&R	Yes	NIPDAU	Level-3-260C-168 HR	-40 to 85	F6777
MSP430F6777IPZR.B	Active	Production	LQFP (PZ) 100	1000 LARGE T&R	Yes	NIPDAU	Level-3-260C-168 HR	-40 to 85	F6777
MSP430F6778IPEU	Active	Production	LQFP (PEU) 128	72 JEDEC TRAY (10+1)	Yes	NIPDAU	Level-3-260C-168 HR	-40 to 85	F6778
MSP430F6778IPEU.B	Active	Production	LQFP (PEU) 128	72 JEDEC TRAY (10+1)	Yes	NIPDAU	Level-3-260C-168 HR	-40 to 85	F6778
MSP430F6778IPZ	Active	Production	LQFP (PZ) 100	90 JEDEC TRAY (10+1)	Yes	NIPDAU	Level-3-260C-168 HR	-40 to 85	F6778
MSP430F6778IPZ.B	Active	Production	LQFP (PZ) 100	90 JEDEC TRAY (10+1)	Yes	NIPDAU	Level-3-260C-168 HR	-40 to 85	F6778
MSP430F6779IPEU	Active	Production	LQFP (PEU) 128	72 JEDEC TRAY (10+1)	Yes	NIPDAU	Level-3-260C-168 HR	-40 to 85	F6779
MSP430F6779IPEU.B	Active	Production	LQFP (PEU) 128	72 JEDEC TRAY (10+1)	Yes	NIPDAU	Level-3-260C-168 HR	-40 to 85	F6779
MSP430F6779IPEUR	Active	Production	LQFP (PEU) 128	750 LARGE T&R	Yes	NIPDAU	Level-3-260C-168 HR	-40 to 85	F6779
MSP430F6779IPEUR.B	Active	Production	LQFP (PEU) 128	750 LARGE T&R	Yes	NIPDAU	Level-3-260C-168 HR	-40 to 85	F6779
MSP430F6779IPZ	Active	Production	LQFP (PZ) 100	90 JEDEC TRAY (10+1)	Yes	NIPDAU	Level-3-260C-168 HR	-40 to 85	F6779
MSP430F6779IPZ.B	Active	Production	LQFP (PZ) 100	90 JEDEC TRAY (10+1)	Yes	NIPDAU	Level-3-260C-168 HR	-40 to 85	F6779

Orderable part number	Status (1)	Material type (2)	Package Pins	Package qty Carrier	RoHS (3)	Lead finish/ Ball material (4)	MSL rating/ Peak reflow (5)	Op temp (°C)	Part marking (6)
MSP430F6779IPZR	Active	Production	LQFP (PZ) 100	1000 LARGE T&R	Yes	NIPDAU	Level-3-260C-168 HR	-40 to 85	F6779
MSP430F6779IPZR.B	Active	Production	LQFP (PZ) 100	1000 LARGE T&R	Yes	NIPDAU	Level-3-260C-168 HR	-40 to 85	F6779

(1) **Status:** For more details on status, see our [product life cycle](#).

(2) **Material type:** When designated, preproduction parts are prototypes/experimental devices, and are not yet approved or released for full production. Testing and final process, including without limitation quality assurance, reliability performance testing, and/or process qualification, may not yet be complete, and this item is subject to further changes or possible discontinuation. If available for ordering, purchases will be subject to an additional waiver at checkout, and are intended for early internal evaluation purposes only. These items are sold without warranties of any kind.

(3) **RoHS values:** Yes, No, RoHS Exempt. See the [TI RoHS Statement](#) for additional information and value definition.

(4) **Lead finish/Ball material:** Parts may have multiple material finish options. Finish options are separated by a vertical ruled line. Lead finish/Ball material values may wrap to two lines if the finish value exceeds the maximum column width.

(5) **MSL rating/Peak reflow:** The moisture sensitivity level ratings and peak solder (reflow) temperatures. In the event that a part has multiple moisture sensitivity ratings, only the lowest level per JEDEC standards is shown. Refer to the shipping label for the actual reflow temperature that will be used to mount the part to the printed circuit board.

(6) **Part marking:** There may be an additional marking, which relates to the logo, the lot trace code information, or the environmental category of the part.

Multiple part markings will be inside parentheses. Only one part marking contained in parentheses and separated by a "-" will appear on a part. If a line is indented then it is a continuation of the previous line and the two combined represent the entire part marking for that device.

Important Information and Disclaimer: The information provided on this page represents TI's knowledge and belief as of the date that it is provided. TI bases its knowledge and belief on information provided by third parties, and makes no representation or warranty as to the accuracy of such information. Efforts are underway to better integrate information from third parties. TI has taken and continues to take reasonable steps to provide representative and accurate information but may not have conducted destructive testing or chemical analysis on incoming materials and chemicals. TI and TI suppliers consider certain information to be proprietary, and thus CAS numbers and other limited information may not be available for release.

In no event shall TI's liability arising out of such information exceed the total purchase price of the TI part(s) at issue in this document sold by TI to Customer on an annual basis.

TAPE AND REEL INFORMATION

QUADRANT ASSIGNMENTS FOR PIN 1 ORIENTATION IN TAPE

*All dimensions are nominal

Device	Package Type	Package Drawing	Pins	SPQ	Reel Diameter (mm)	Reel Width W1 (mm)	A0 (mm)	B0 (mm)	K0 (mm)	P1 (mm)	W (mm)	Pin1 Quadrant
MSP430F6747IPZR	LQFP	PZ	100	1000	330.0	24.4	17.0	17.0	2.1	20.0	24.0	Q2
MSP430F6765IPZR	LQFP	PZ	100	1000	330.0	24.4	17.0	17.0	2.1	20.0	24.0	Q2
MSP430F6775IPZR	LQFP	PZ	100	1000	330.0	24.4	17.0	17.0	2.1	20.0	24.0	Q2
MSP430F6777IPZR	LQFP	PZ	100	1000	330.0	24.4	17.0	17.0	2.1	20.0	24.0	Q2
MSP430F6779IPZR	LQFP	PZ	100	1000	330.0	24.4	17.0	17.0	2.1	20.0	24.0	Q2

TAPE AND REEL BOX DIMENSIONS

*All dimensions are nominal

Device	Package Type	Package Drawing	Pins	SPQ	Length (mm)	Width (mm)	Height (mm)
MSP430F67471PZR	LQFP	PZ	100	1000	350.0	350.0	43.0
MSP430F67651PZR	LQFP	PZ	100	1000	350.0	350.0	43.0
MSP430F67751PZR	LQFP	PZ	100	1000	350.0	350.0	43.0
MSP430F67771PZR	LQFP	PZ	100	1000	350.0	350.0	43.0
MSP430F67791PZR	LQFP	PZ	100	1000	350.0	350.0	43.0

TRAY

Chamfer on Tray corner indicates Pin 1 orientation of packed units.

*All dimensions are nominal

Device	Package Name	Package Type	Pins	SPQ	Unit array matrix	Max temperature (°C)	L (mm)	W (mm)	K0 (µm)	P1 (mm)	CL (mm)	CW (mm)
MSP430F6745IPEU	PEU	LQFP	128	72	6X12	150	315	135.9	7620	25.4	17.8	15.45
MSP430F6745IPEU.B	PEU	LQFP	128	72	6X12	150	315	135.9	7620	25.4	17.8	15.45
MSP430F6745IPZ	PZ	LQFP	100	90	6 x 15	150	315	135.9	7620	20.3	15.4	15.45
MSP430F6745IPZ.B	PZ	LQFP	100	90	6 x 15	150	315	135.9	7620	20.3	15.4	15.45
MSP430F6746IPEU	PEU	LQFP	128	72	6X12	150	315	135.9	7620	25.4	17.8	15.45
MSP430F6746IPEU.B	PEU	LQFP	128	72	6X12	150	315	135.9	7620	25.4	17.8	15.45
MSP430F6746IPZ	PZ	LQFP	100	90	6 x 15	150	315	135.9	7620	20.3	15.4	15.45
MSP430F6746IPZ.B	PZ	LQFP	100	90	6 x 15	150	315	135.9	7620	20.3	15.4	15.45
MSP430F6747IPEU	PEU	LQFP	128	72	6X12	150	315	135.9	7620	25.4	17.8	15.45
MSP430F6747IPEU.B	PEU	LQFP	128	72	6X12	150	315	135.9	7620	25.4	17.8	15.45
MSP430F6747IPZ	PZ	LQFP	100	90	6 x 15	150	315	135.9	7620	20.3	15.4	15.45
MSP430F6747IPZ.B	PZ	LQFP	100	90	6 x 15	150	315	135.9	7620	20.3	15.4	15.45
MSP430F6748IPEU	PEU	LQFP	128	72	6X12	150	315	135.9	7620	25.4	17.8	15.45
MSP430F6748IPEU.B	PEU	LQFP	128	72	6X12	150	315	135.9	7620	25.4	17.8	15.45
MSP430F6748IPZ	PZ	LQFP	100	90	6 x 15	150	315	135.9	7620	20.3	15.4	15.45
MSP430F6748IPZ.B	PZ	LQFP	100	90	6 x 15	150	315	135.9	7620	20.3	15.4	15.45
MSP430F6749IPEU	PEU	LQFP	128	72	6X12	150	315	135.9	7620	25.4	17.8	15.45

Device	Package Name	Package Type	Pins	SPQ	Unit array matrix	Max temperature (°C)	L (mm)	W (mm)	K0 (µm)	P1 (mm)	CL (mm)	CW (mm)
MSP430F6749IPEU.B	PEU	LQFP	128	72	6X12	150	315	135.9	7620	25.4	17.8	15.45
MSP430F6749IPZ	PZ	LQFP	100	90	6 x 15	150	315	135.9	7620	20.3	15.4	15.45
MSP430F6749IPZ.B	PZ	LQFP	100	90	6 x 15	150	315	135.9	7620	20.3	15.4	15.45
MSP430F6765IPEU	PEU	LQFP	128	72	6X12	150	315	135.9	7620	25.4	17.8	15.45
MSP430F6765IPEU.B	PEU	LQFP	128	72	6X12	150	315	135.9	7620	25.4	17.8	15.45
MSP430F6765IPZ	PZ	LQFP	100	90	6 x 15	150	315	135.9	7620	20.3	15.4	15.45
MSP430F6765IPZ.B	PZ	LQFP	100	90	6 x 15	150	315	135.9	7620	20.3	15.4	15.45
MSP430F6766IPEU	PEU	LQFP	128	72	6X12	150	315	135.9	7620	25.4	17.8	15.45
MSP430F6766IPEU.B	PEU	LQFP	128	72	6X12	150	315	135.9	7620	25.4	17.8	15.45
MSP430F6766IPZ	PZ	LQFP	100	90	6 x 15	150	315	135.9	7620	20.3	15.4	15.45
MSP430F6766IPZ.B	PZ	LQFP	100	90	6 x 15	150	315	135.9	7620	20.3	15.4	15.45
MSP430F6767IPEU	PEU	LQFP	128	72	6X12	150	315	135.9	7620	25.4	17.8	15.45
MSP430F6767IPEU.B	PEU	LQFP	128	72	6X12	150	315	135.9	7620	25.4	17.8	15.45
MSP430F6767IPZ	PZ	LQFP	100	90	6 x 15	150	315	135.9	7620	20.3	15.4	15.45
MSP430F6767IPZ.B	PZ	LQFP	100	90	6 x 15	150	315	135.9	7620	20.3	15.4	15.45
MSP430F6768IPEU	PEU	LQFP	128	72	6X12	150	315	135.9	7620	25.4	17.8	15.45
MSP430F6768IPEU.B	PEU	LQFP	128	72	6X12	150	315	135.9	7620	25.4	17.8	15.45
MSP430F6768IPZ	PZ	LQFP	100	90	6 x 15	150	315	135.9	7620	20.3	15.4	15.45
MSP430F6768IPZ.B	PZ	LQFP	100	90	6 x 15	150	315	135.9	7620	20.3	15.4	15.45
MSP430F6769IPEU	PEU	LQFP	128	72	6X12	150	315	135.9	7620	25.4	17.8	15.45
MSP430F6769IPEU.B	PEU	LQFP	128	72	6X12	150	315	135.9	7620	25.4	17.8	15.45
MSP430F6769IPZ	PZ	LQFP	100	90	6 x 15	150	315	135.9	7620	20.3	15.4	15.45
MSP430F6769IPZ.B	PZ	LQFP	100	90	6 x 15	150	315	135.9	7620	20.3	15.4	15.45
MSP430F6775IPEU	PEU	LQFP	128	72	6X12	150	315	135.9	7620	25.4	17.8	15.45
MSP430F6775IPEU.B	PEU	LQFP	128	72	6X12	150	315	135.9	7620	25.4	17.8	15.45
MSP430F6775IPZ	PZ	LQFP	100	90	6 x 15	150	315	135.9	7620	20.3	15.4	15.45
MSP430F6775IPZ.B	PZ	LQFP	100	90	6 x 15	150	315	135.9	7620	20.3	15.4	15.45
MSP430F6776IPEU	PEU	LQFP	128	72	6X12	150	315	135.9	7620	25.4	17.8	15.45
MSP430F6776IPEU.B	PEU	LQFP	128	72	6X12	150	315	135.9	7620	25.4	17.8	15.45
MSP430F6776IPZ	PZ	LQFP	100	90	6 x 15	150	315	135.9	7620	20.3	15.4	15.45
MSP430F6776IPZ.B	PZ	LQFP	100	90	6 x 15	150	315	135.9	7620	20.3	15.4	15.45
MSP430F6777IPEU	PEU	LQFP	128	72	6X12	150	315	135.9	7620	25.4	17.8	15.45
MSP430F6777IPEU.B	PEU	LQFP	128	72	6X12	150	315	135.9	7620	25.4	17.8	15.45
MSP430F6777IPZ	PZ	LQFP	100	90	6 x 15	150	315	135.9	7620	20.3	15.4	15.45
MSP430F6777IPZ.B	PZ	LQFP	100	90	6 x 15	150	315	135.9	7620	20.3	15.4	15.45
MSP430F6778IPEU	PEU	LQFP	128	72	6X12	150	315	135.9	7620	25.4	17.8	15.45
MSP430F6778IPEU.B	PEU	LQFP	128	72	6X12	150	315	135.9	7620	25.4	17.8	15.45
MSP430F6778IPZ	PZ	LQFP	100	90	6 x 15	150	315	135.9	7620	20.3	15.4	15.45
MSP430F6778IPZ.B	PZ	LQFP	100	90	6 x 15	150	315	135.9	7620	20.3	15.4	15.45
MSP430F6779IPEU	PEU	LQFP	128	72	6X12	150	315	135.9	7620	25.4	17.8	15.45
MSP430F6779IPEU.B	PEU	LQFP	128	72	6X12	150	315	135.9	7620	25.4	17.8	15.45

Device	Package Name	Package Type	Pins	SPQ	Unit array matrix	Max temperature (°C)	L (mm)	W (mm)	K0 (µm)	P1 (mm)	CL (mm)	CW (mm)
MSP430F6779IPZ	PZ	LQFP	100	90	6 x 15	150	315	135.9	7620	20.3	15.4	15.45
MSP430F6779IPZ.B	PZ	LQFP	100	90	6 x 15	150	315	135.9	7620	20.3	15.4	15.45

MECHANICAL DATA

PEU (R-PQFP-G128)

PLASTIC QUAD FLATPACK

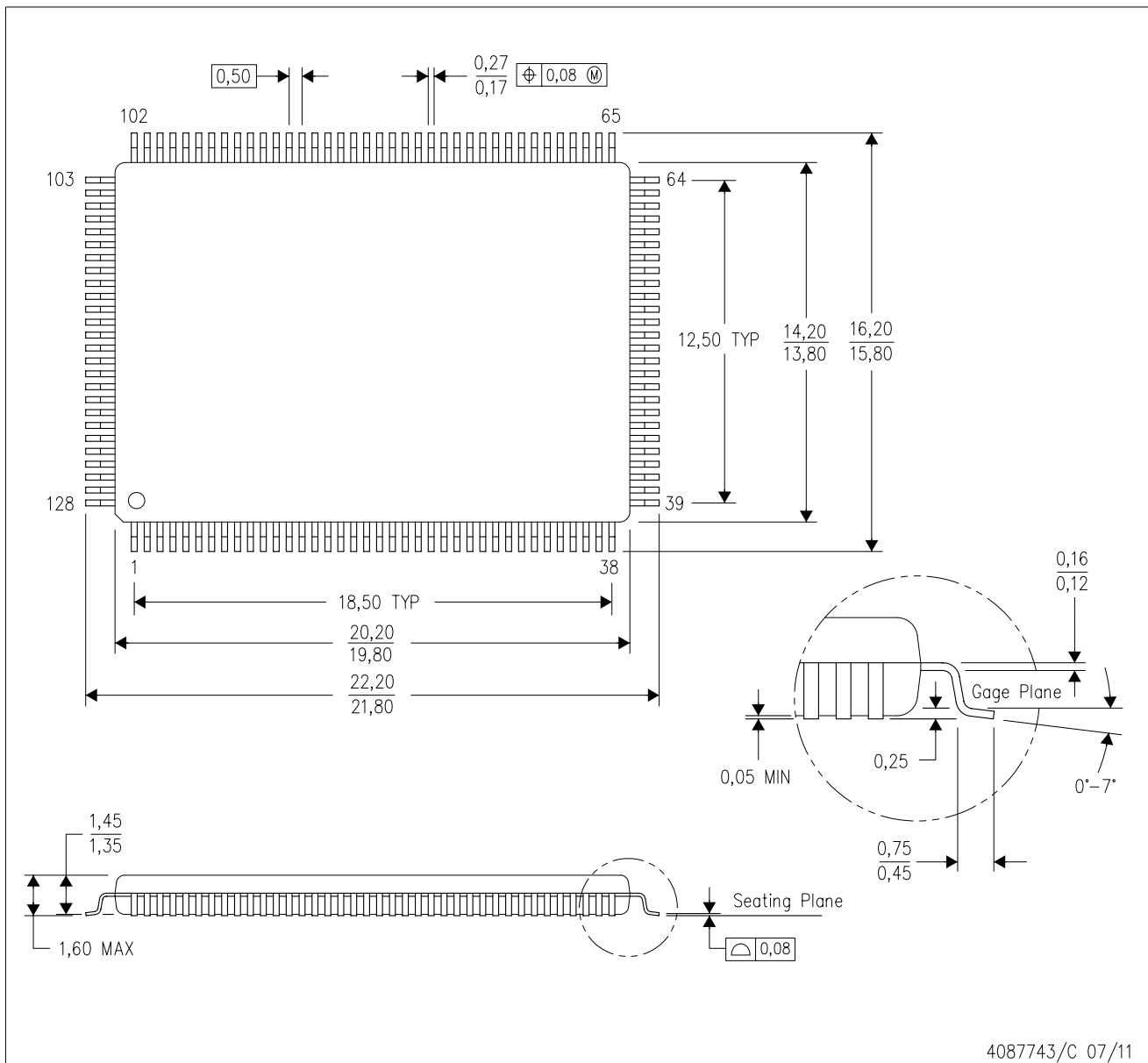

- NOTES:
- A. All linear dimensions are in millimeters. Dimensioning and tolerancing per ASME Y14.5M-1994.
 - B. This drawing is subject to change without notice.
 - C. Falls within JEDEC MS-026

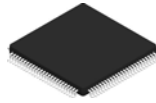

PACKAGE OUTLINE

PZ0100A

LQFP - 1.6 mm max height

PLASTIC QUAD FLATPACK

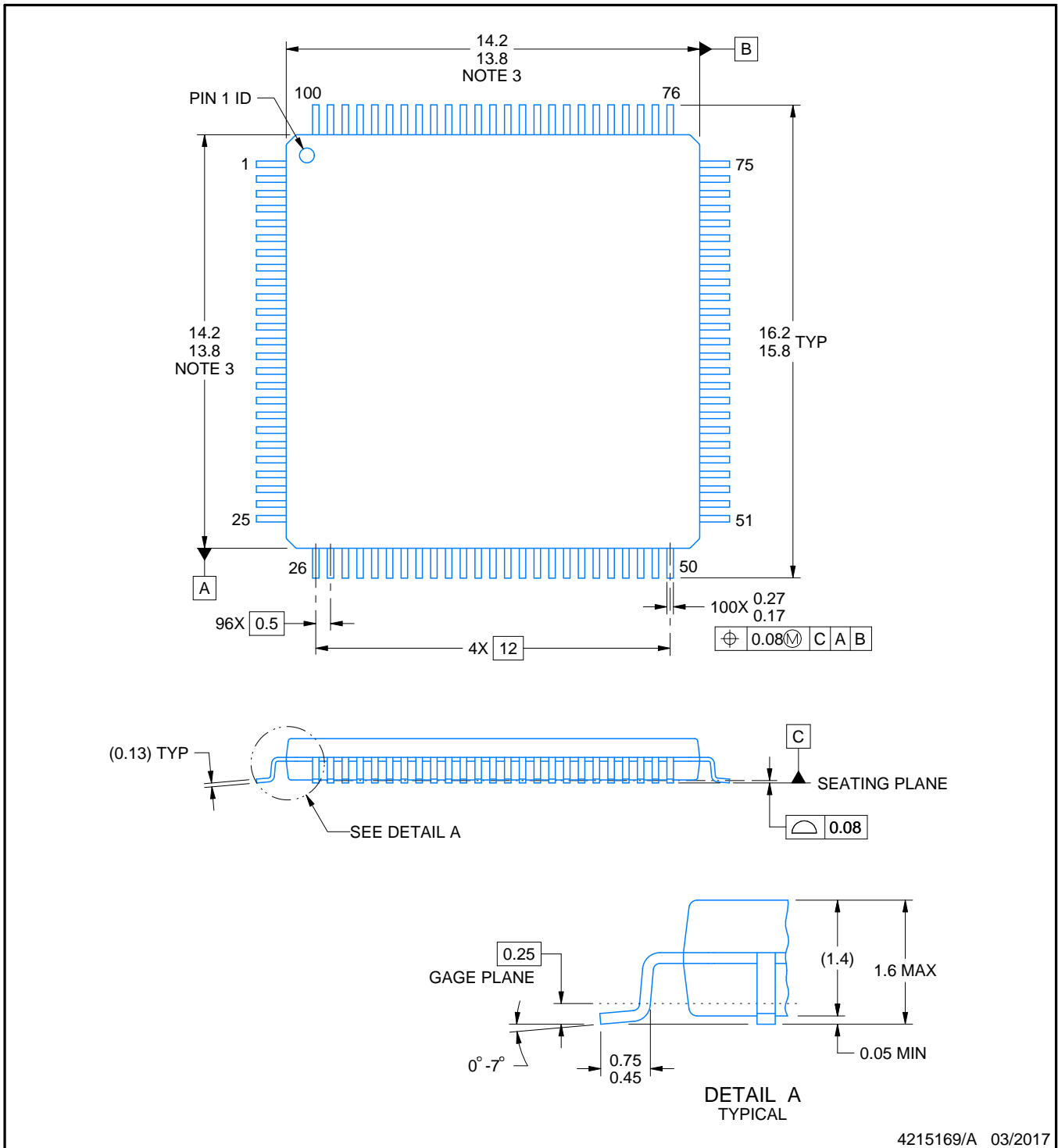

NOTES:

1. All linear dimensions are in millimeters. Any dimensions in parenthesis are for reference only. Dimensioning and tolerancing per ASME Y14.5M.
2. This drawing is subject to change without notice.
3. This dimension does not include mold flash, protrusions, or gate burrs. Mold flash, protrusions, or gate burrs shall not exceed 0.15 mm per side.
4. Reference JEDEC registration MS-026.

EXAMPLE BOARD LAYOUT

PZ0100A

LQFP - 1.6 mm max height

PLASTIC QUAD FLATPACK

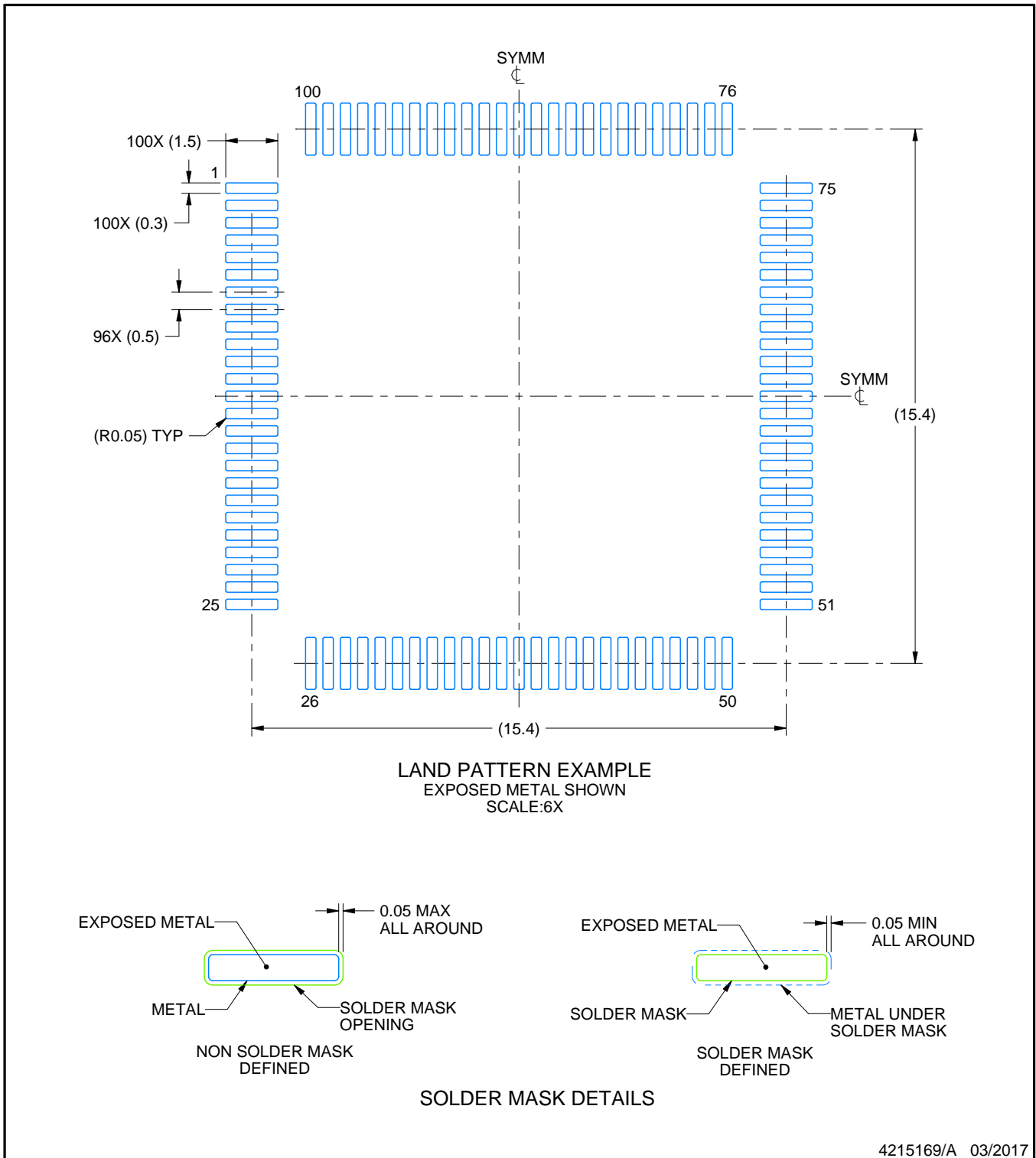

NOTES: (continued)

5. Publication IPC-7351 may have alternate designs.
6. Solder mask tolerances between and around signal pads can vary based on board fabrication site.
7. For more information, see Texas Instruments literature number SLMA004 (www.ti.com/lit/slma004).

EXAMPLE STENCIL DESIGN

PZ0100A

LQFP - 1.6 mm max height

PLASTIC QUAD FLATPACK

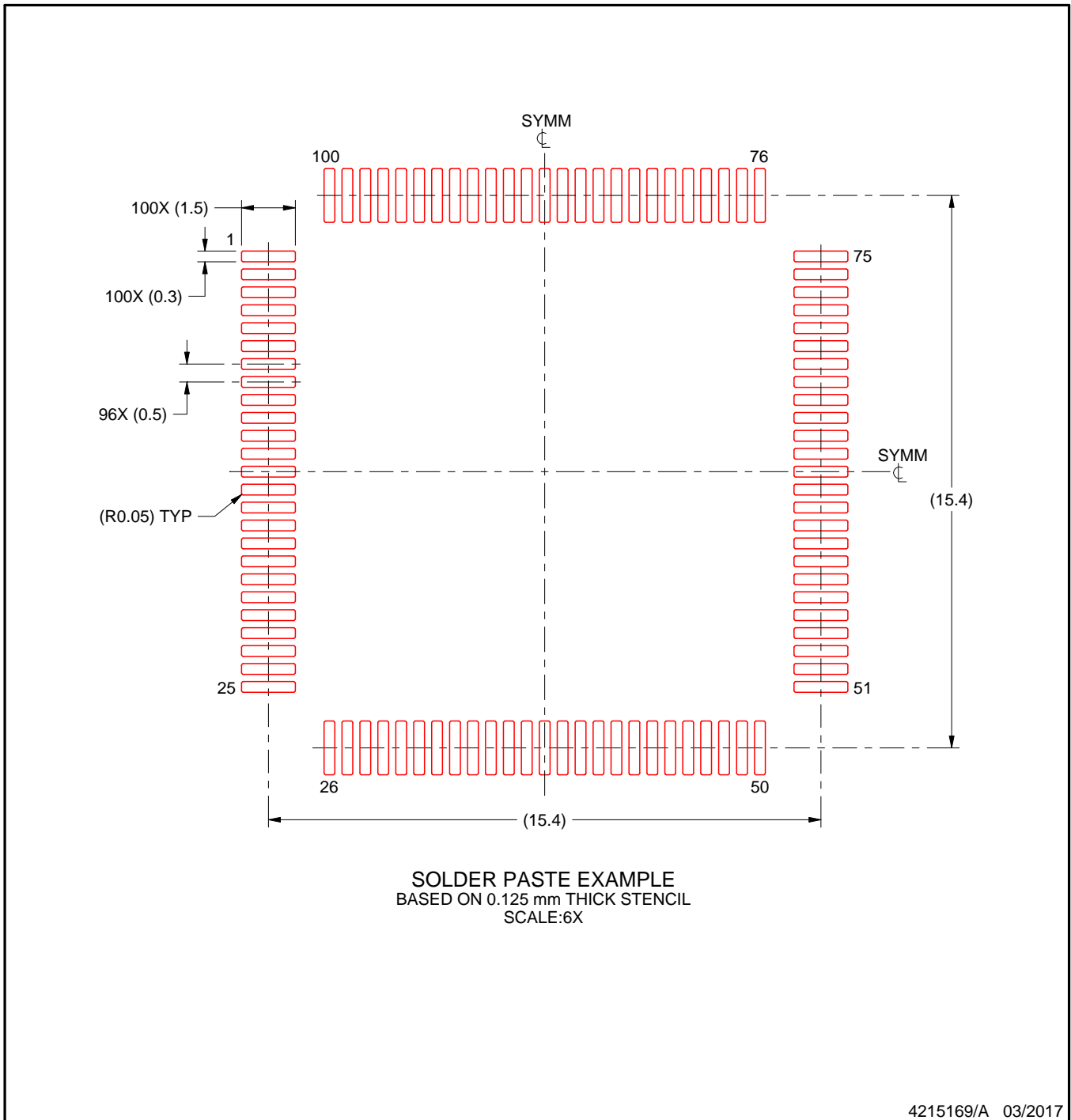

NOTES: (continued)

8. Laser cutting apertures with trapezoidal walls and rounded corners may offer better paste release. IPC-7525 may have alternate design recommendations.
9. Board assembly site may have different recommendations for stencil design.

重要なお知らせと免責事項

テキサス・インスツルメンツは、技術データと信頼性データ(データシートを含みます)、設計リソース(リファレンス デザインを含みます)、アプリケーションや設計に関する各種アドバイス、Web ツール、安全性情報、その他のリソースを、欠陥が存在する可能性のある「現状のまま」提供しており、商品性および特定目的に対する適合性の黙示保証、第三者の知的財産権の非侵害保証を含むいかなる保証も、明示的または黙示的にかかわらず拒否します。

これらのリソースは、テキサス・インスツルメンツ製品を使用する設計の経験を積んだ開発者への提供を意図したものです。(1) お客様のアプリケーションに適したテキサス・インスツルメンツ製品の選定、(2) お客様のアプリケーションの設計、検証、試験、(3) お客様のアプリケーションに該当する各種規格や、その他のあらゆる安全性、セキュリティ、規制、または他の要件への確実な適合に関する責任を、お客様のみが単独で負うものとし、ます。

上記の各種リソースは、予告なく変更される可能性があります。これらのリソースは、リソースで説明されているテキサス・インスツルメンツ製品を使用するアプリケーションの開発の目的でのみ、テキサス・インスツルメンツはその使用をお客様に許諾します。これらのリソースに関して、他の目的で複製することや掲載することは禁止されています。テキサス・インスツルメンツや第三者の知的財産権のライセンスが付与されている訳ではありません。お客様は、これらのリソースを自身で使用した結果発生するあらゆる申し立て、損害、費用、損失、責任について、テキサス・インスツルメンツおよびその代理人を完全に補償するものとし、テキサス・インスツルメンツは一切の責任を拒否します。

テキサス・インスツルメンツの製品は、[テキサス・インスツルメンツの販売条件](#)、または [ti.com](https://www.ti.com) やかかるテキサス・インスツルメンツ製品の関連資料などのいずれかを通じて提供する適用可能な条項の下で提供されています。テキサス・インスツルメンツがこれらのリソースを提供することは、適用されるテキサス・インスツルメンツの保証または他の保証の放棄の拡大や変更を意味するものではありません。

お客様がいかなる追加条項または代替条項を提案した場合でも、テキサス・インスツルメンツはそれらに異議を唱え、拒否します。

郵送先住所：Texas Instruments, Post Office Box 655303, Dallas, Texas 75265
Copyright © 2025, Texas Instruments Incorporated