

# LMG1025-Q1 高周波および狭パルス アプリケーション向け車載ローサイド GaN および MOSFET ドライバ

## 1 特長

- AEC-Q100 グレード 1 認定済み
- 最小入力パルス幅: 1.25ns (標準値)
- 立ち上がり伝搬遅延時間: 2.6ns (標準値)
- 立ち下がり伝搬遅延時間: 2.9ns (標準値)
- パルス歪み: 300ps (標準値)
- 独立した 7A プルアップ電流および 5A プルダウン電流
- 立ち上がり時間: 650ps (220pF 負荷、標準値)
- 立ち下がり時間: 850ps (220pF 負荷、標準値)
- 2mm × 2mm の QFN パッケージ
- 反転入力、非反転入力
- UVLO と過熱保護
- 5V 単一電源電圧

## 2 アプリケーション

- 車載用 LIDAR
- ドライバ監視
- 車両占有検出センサ
- DC/DC コンバータ

## 3 概要

LMG1025-Q1 は、スイッチング周波数の高い車載アプリケーション向けのシングル チャネル ローサイド エンハンスメントモード GaN FET およびロジックレベル MOSFET ドライバです。狭パルス幅機能、高速スイッチング仕様、小さなパルス歪みを組み合わせることで、LiDAR、ToF、および電力コンバータの性能が大幅に向上します。1.25ns の出力パルス幅により、より強力な目に安全なダイオードパルスが可能になります。これを歪み 300ns と組み合わせることで、長距離で高精度の LiDAR/ToF システムを実現できます。2.9ns の伝搬遅延により、制御ループの応答時間が大幅に短くなり、パワーコンバータの全体的な性能が大幅に向上します。分割出力が可能なので、OUTH、OUTL、FET ゲート間の外付け抵抗により、駆動能力とタイミングを別々に調整できます。

ドライバには、過負荷またはフォルト状態でデバイスが損傷しないようにするために、低電圧誤動作防止 (UVLO) および過熱保護 (OTP) 機能があります。LMG1025-Q1 は、小型のリードレス AEC-Q100 車載認定パッケージで供給され、スイッチング周波数の高い車載アプリケーションのサイズとゲート ループ インダクタンス要件を満たします。

### 製品情報

部品番号	パッケージ <sup>(1)</sup>	本体サイズ (公称)
LMG1025QDRVRQ1	DRV (WSON, 6)	2 mm × 2mm
LMG1025QDEERQ1	DEE (WSON 6)	2 mm × 2mm

(1) 供給されているすべてのパッケージについては、[セクション 12](#) を参照してください。

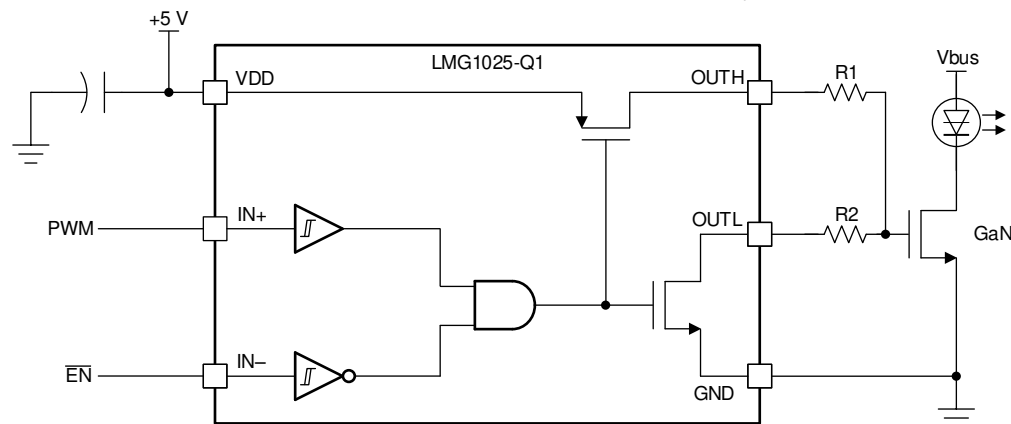

標準的な (簡略) システム図



## Table of Contents

<b>1 特長</b> .....	<b>1</b>	<b>7 Application and Implementation</b> .....	<b>10</b>
<b>2 アプリケーション</b> .....	<b>1</b>	7.1 Application Information.....	10
<b>3 概要</b> .....	<b>1</b>	7.2 Typical Application.....	10
<b>4 Pin Configuration and Functions</b> .....	<b>3</b>	<b>8 Power Supply Recommendations</b> .....	<b>16</b>
<b>5 Specifications</b> .....	<b>4</b>	<b>9 Layout</b> .....	<b>17</b>
5.1 Absolute Maximum Ratings.....	4	9.1 Layout Guidelines.....	17
5.2 ESD Ratings.....	4	9.2 Layout Example.....	17
5.3 Recommended Operating Conditions.....	4	<b>10 Device and Documentation Support</b> .....	<b>18</b>
5.4 Thermal Information.....	4	10.1 Device Support.....	18
5.5 Electrical Characteristics.....	5	10.2 ドキュメントの更新通知を受け取る方法.....	18
5.6 Switching Characteristics.....	5	10.3 サポート・リソース.....	18
5.7 Typical Characteristics.....	6	10.4 静電気放電に関する注意事項.....	18
<b>6 Detailed Description</b> .....	<b>8</b>	10.5 Trademarks.....	18
6.1 Overview.....	8	10.6 用語集.....	18
6.2 Functional Block Diagram.....	8	<b>11 Revision History</b> .....	<b>18</b>
6.3 Feature Description.....	8	<b>12 Mechanical, Packaging, and Orderable Information</b> .....	<b>19</b>
6.4 Device Functional Modes.....	9		

## 4 Pin Configuration and Functions



図 4-1. DEE 6-Pin WSON Top View



図 4-2. DRV 6-Pin WSON Top View

表 4-1. Pin Functions

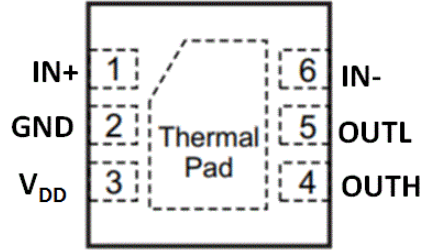
PIN		I/O <sup>(1)</sup>	DESCRIPTION
NAME	NO.		
GND	2	G	Power supply and source return. Connect with a direct path to the transistor's source.
IN+	1	I	Positive logic-level input.
IN-	6	I	Negative logic-level input.
OUTL	5	O	Pull-down gate drive output. Connect through an optional resistor to the target transistor's gate.
OUTH	4	O	Pull-up gate drive output. Connect through a resistor to the target transistor's gate.
VDD	3	P	Input voltage supply. Decouple through a compact capacitor to GND.
Thermal Pad	-	-	Internally connected to GND through substrate. Connect this pad to large copper area, generally a ground plane.

(1) I=Input, O=Output, P=Power, G=Ground

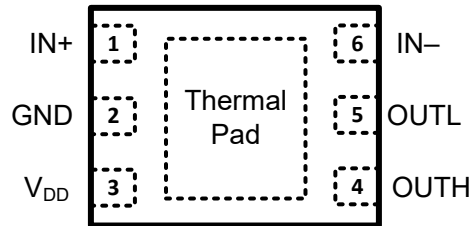
## 5 Specifications

### 5.1 Absolute Maximum Ratings

All voltages are with respect to GND pin.<sup>(1)</sup>

		MIN	MAX	UNIT
V <sub>DD</sub>	Supply voltage	0	5.75	V
V <sub>IN</sub>	IN+, IN- pin voltage	-0.3	V <sub>DD</sub> + 0.3	V
V <sub>OUT</sub>	OUTH, OUTL pin voltage	-0.3	5.75	V
T <sub>STG</sub>	Storage Temperature	-55	150	°C
T <sub>J</sub>	Operating Temperature	-40	150	°C

- (1) Stresses beyond those listed under *Absolute Maximum Rating* may cause permanent damage to the device. These are stress ratings only, which do not imply functional operation of the device at these or any other conditions beyond those indicated under *Recommended Operating Condition*. Exposure to absolute-maximum-rated conditions for extended periods may affect device reliability.

### 5.2 ESD Ratings

			VALUE	UNIT
V <sub>(ESD)</sub>	Electrostatic discharge	Human body model (HBM), per AEC Q100-002 <sup>(1)</sup>	±2000	V
		Charged device model (CDM), per AEC Q100-011	±500	

- (1) AEC Q100-002 indicates that HBM stressing shall be in accordance with the ANSI/ESDA/JEDEC JS-001 specification.

### 5.3 Recommended Operating Conditions

over operating free-air temperature range (unless otherwise noted)

		MIN	NOM	MAX	UNIT
V <sub>DD</sub>	Supply voltage	4.75	5	5.25	V
V <sub>INx</sub>	IN+ or IN- input voltage	0		V <sub>DD</sub>	V
V <sub>OUTx</sub>	OUTH, OUTL pin voltage	0		5.25	V
T <sub>J</sub>	Operating Temperature	-40		125	°C

### 5.4 Thermal Information

THERMAL METRIC <sup>(1)</sup>		LMG1025-Q1		UNIT
		DRV (WSON)	DEE (WSON)	
		6 PINS	6 PINS	
R <sub>θJA</sub>	Junction-to-ambient thermal resistance	72.4	66.7	°C/W
R <sub>θJC(top)</sub>	Junction-to-case (top) thermal resistance	90.1	87.3	°C/W
R <sub>θJB</sub>	Junction-to-board thermal resistance	35.8	30.8	°C/W
Ψ <sub>JT</sub>	Junction-to-top characterization parameter	3.1	2.2	°C/W
Y <sub>JB</sub>	Junction-to-board characterization parameter	35.8	30.7	°C/W
R <sub>θJC(bot)</sub>	Junction-to-case (bottom) thermal resistance	13.8	6.7	°C/W

- (1) For more information about traditional and new thermal metrics, see the [Semiconductor and IC Package Thermal Metrics](#) application report.

## 5.5 Electrical Characteristics

VDD = 5V, good feed-through bypass capacitor from VDD to GND pin, over operating free-air temperature range (unless otherwise noted)

PARAMETER		TEST CONDITIONS	MIN	TYP	MAX	UNIT
<b>DC Characteristics</b>						
I <sub>VDD, Q</sub>	VDD Quiescent Current	IN <sub>+</sub> = IN <sub>-</sub> = 0 V			75	μA
I <sub>VDD, op</sub>	VDD Operating Current	fsw = 30 MHz, no load, 2Ω as R <sub>OUTH</sub> and R <sub>OUTL</sub>		40		mA
		fsw = 30 MHz, 100-pF load, 2Ω as R <sub>OUTH</sub> and R <sub>OUTL</sub>		51		mA
V <sub>DD, UVLO</sub>	Under-voltage Lockout	V <sub>DD</sub> rising	4.0		4.35	V
ΔV <sub>DD, UVLO</sub>	UVLO Hysteresis			85		mV
T <sub>OTP</sub>	Over temperature shutdown, turn-off threshold			170		°C
ΔT <sub>OTP</sub>	Over temperature hysteresis			20		°C
<b>Input DC Characteristics</b>						
V <sub>IH</sub>	IN <sub>+</sub> , IN <sub>-</sub> high threshold		1.7		2.6	V
V <sub>IL</sub>	IN <sub>+</sub> , IN <sub>-</sub> low threshold		1.1		1.8	V
V <sub>HYST</sub>	IN <sub>+</sub> , IN <sub>-</sub> hysteresis		0.38		1	V
R <sub>IN+</sub>	Positive input pull-down resistance	To GND	100	150	250	kΩ
R <sub>IN-</sub>	Negative input pull-up resistance	to V <sub>DD</sub>	100	150	250	kΩ
C <sub>IN+</sub>	Positive input pin capacitance	To GND		1.45		pF
C <sub>IN-</sub>	Negative input pin capacitance	To GND		1.45		pF
<b>Output DC Characteristics</b>						
V <sub>OL</sub>	OUTL voltage	I <sub>OUTL</sub> = 100 mA, IN <sub>+</sub> = IN <sub>-</sub> = 0 V			45	mV
V <sub>DD</sub> -V <sub>OH</sub>	OUTH voltage	I <sub>OUTH</sub> = 100 mA, IN <sub>+</sub> = 5 V, IN <sub>-</sub> = 0 V, V <sub>DD</sub> = 5 V			52	mV
I <sub>OH</sub>	Peak source current	V <sub>OUTH</sub> = 0 V, IN <sub>+</sub> = 5 V, IN <sub>-</sub> = 0 V, V <sub>DD</sub> = 5 V		7		A
I <sub>OL</sub>	Peak sink current	V <sub>OUTL</sub> = 5 V, IN <sub>+</sub> = IN <sub>-</sub> = 0 V, V <sub>DD</sub> = 5 V		5		A

## 5.6 Switching Characteristics

over operating free-air temperature range (unless otherwise noted)

PARAMETER		TEST CONDITIONS	MIN	TYP	MAX	UNIT
t <sub>start</sub>	Startup Time, V <sub>DD</sub> rising above UVLO	IN <sub>-</sub> = GND, IN <sub>+</sub> = V <sub>DD</sub> , V <sub>DD</sub> rising above 4.4 V to OUTH rising		40	78	μs
t <sub>shut-off</sub>	ULVO falling	IN <sub>-</sub> = GND, IN <sub>+</sub> = V <sub>DD</sub> , V <sub>DD</sub> falling below 3.9 V to OUTH falling	0.7	2.5	3.5	μs
t <sub>pd, r</sub>	Propagation delay, turn on	IN <sub>-</sub> = 0 V, IN <sub>+</sub> to OUTH, 100-pF load	1.5	2.6	4.1	ns
t <sub>pd, f</sub>	Propagation delay, turn off	IN <sub>-</sub> = 0 V, IN <sub>+</sub> to OUTL, 100-pF load	1.8	2.9	4.4	ns
Δt <sub>pd</sub>	Pulse positive distortion, (t <sub>pd, f</sub> - t <sub>pd, r</sub> )		0	300	610	ps
t <sub>rise</sub>	Output rise time	0Ω series 220 pF load <sup>(1)</sup>		650		ps
t <sub>fall</sub>	Output fall time	0Ω series 220 pF load <sup>(1)</sup>		850		ps
t <sub>min</sub>	Minimum input pulse width that changes output state	0Ω series 220 pF load <sup>(1)</sup>		1.25		ns

(1) Rise and fall time calculated as time from 20% of the gate voltage to 80% of the gate voltage of the GaN FET.

### 5.7 Typical Characteristics

VDD = 5 V

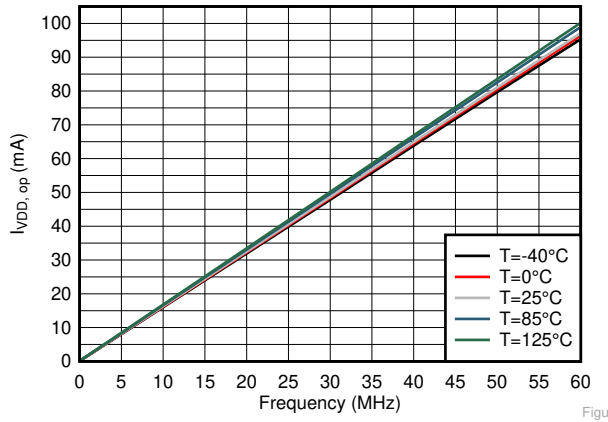

5-1.  $I_{VDD,op}$  with 2  $\Omega$  in Series with 100pF Load

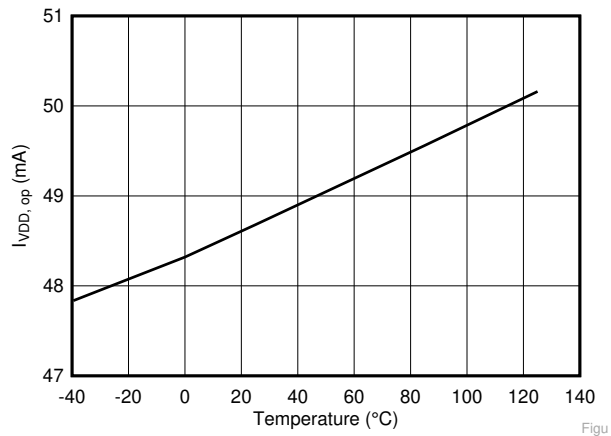

5-2.  $I_{VDD,op}$  with 2  $\Omega$  in Series with 100pF Load

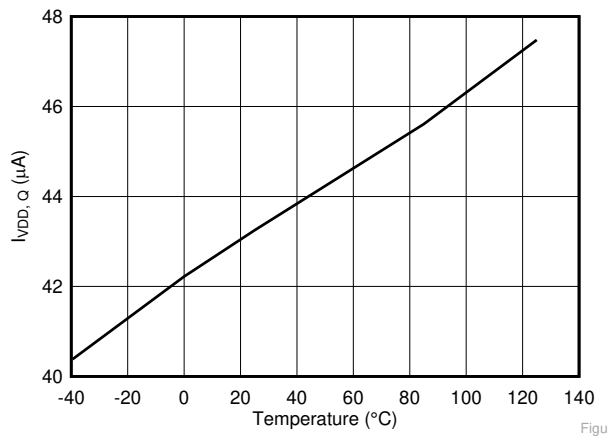

5-3. Quiescent Current

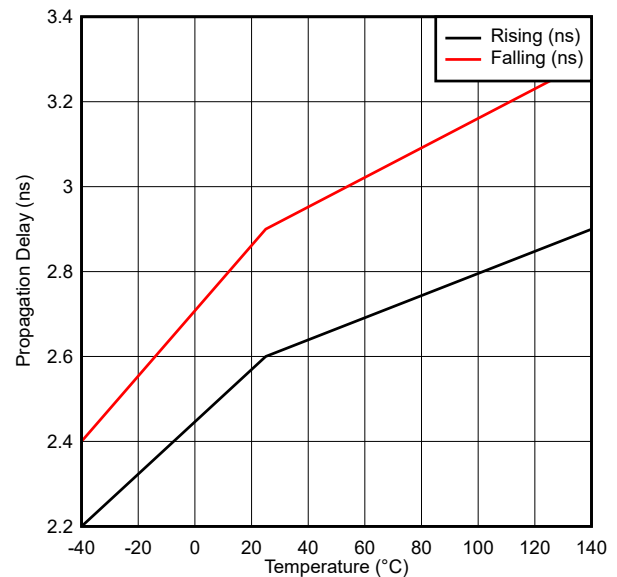

5-4. Propagation Delay with 100pF Load



図 5-5. Rise and Fall Time with 100pF Load

## 6 Detailed Description

### 6.1 Overview

LMG1025-Q1 is a high-performance low-side 5-V gate driver for GaN and logic-level MOSFETs. While it is designed to function well in high-speed applications, such as wireless power transmission and LiDAR/ToF, it can be used in any application where a low-side gate driver is required. The LMG1025-Q1 is optimized to provide the lowest propagation delay through the driver to the power transistor. LMG1025-Q1 is in a small 2mm×2mm QFN package with wettable flanks, in order to minimize its parasitic inductance. This low inductance design is necessary to achieve high current, low ringing performance in very high frequency operation when driving power FETs. The same holds true for when designing with LMG1025-Q1. QFN package with wettable flanks is also needed to improve system robustness in many automotive applications.

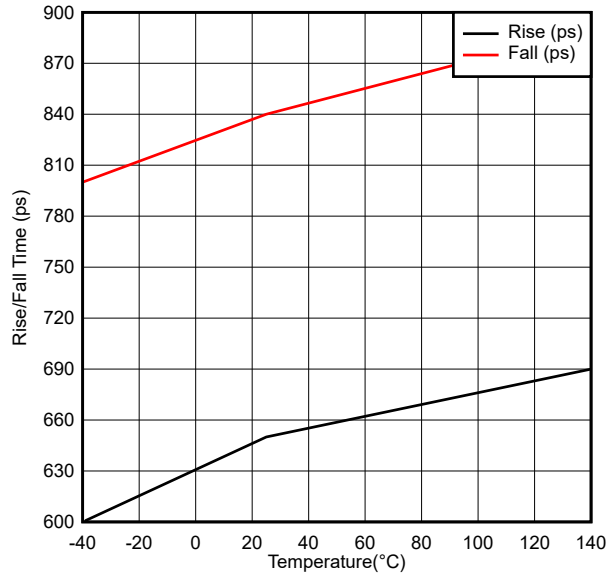
### 6.2 Functional Block Diagram

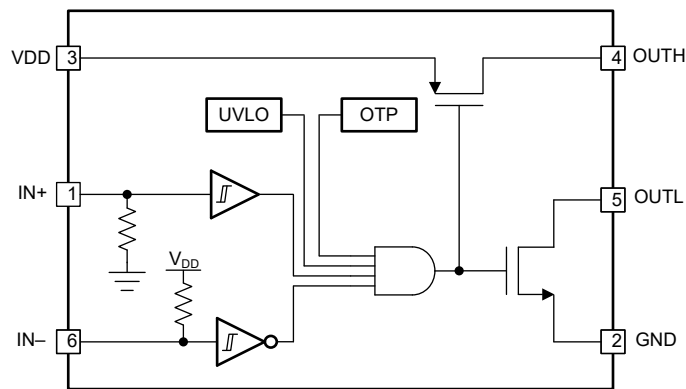

### 6.3 Feature Description

#### 6.3.1 Input Stage

The input stage features two Schmitt-triggers at the pins IN+ and IN– to reduce sensitivity to noise on the inputs. IN+ signal and the inverted IN– signal are both sent to an AND gate. IN+ is connected with a pull-down resistor while IN– is connected with a pull-up resistor to prevent unintended turn-on. The output of the driver will be high when input voltage goes above input thresholds and output goes low when input voltage is below input threshold mentioned in the electrical characteristics table. Both IN+ and IN– are single ended inputs, and these two pins cannot be used as a differential input pair. Parasitic elements become extremely important in high frequency designs and extreme care should be taken while laying out the printed circuit board to minimize these parasitic elements. The performance of the LMG1025-Q1 and the performance of the overall system gets affected by the layout and components being selected.

#### 6.3.2 Output Stage

LMG1025-Q1 provides 7-A source, 5-A sink (asymmetrical drive) peak-drive current capability, and features a split output configuration. The OUTH and OUTL outputs of the LMG1025-Q1 allow the user to use independent resistors connecting to the gate. The two resistors allow the user to independently adjust the turn-on and turn-off drive strengths to control slew rate and EMI, and to control ringing on the gate signal. For GaN FETs, controlling ringing is important to reduce stress on the GaN FET and driver. The output stage OUTL is also pulled down in undervoltage condition, which prevents the unintended charge accumulation of device Ciss, and thus preventing false turn-on. This ringing heavily depends on the layout as switching frequency increases and as rise and fall time gets shorter. The distance between the gate driver and power device need to be as minimum as possible. Gate loop should be as minimum as possible. If ringing is un-avoidable then the gate resistor should be selected in such a way that the ringing is minimized. Bypass capacitor type, value, and position also significantly affects this ringing.



### 6.3.3 Bias Supply and Under Voltage Lockout

LMG1025-Q1 features nominal 5 V and maximum 5.25 V of supply voltage, and its absolute maximum supply voltage is 5.75 V. In the design, it is recommended to limit the variability of the power supply to be within 5% (0.25 V), and the overshoot voltage during switching transient not to exceed the absolute maximum voltage. Refer to Section VDD and Overshoot for more on the detailed design guide. LMG1025-Q1 also features internal undervoltage lockout (UVLO) to protect the driver and circuit in case of fault conditions. The UVLO point is setup between 4.0 V and 4.35 V with a hysteresis of 85mV. This UVLO level is specifically designed to guarantee that GaN power devices can be switched at a low  $R_{DS(ON)}$  region. During UVLO condition, the OUTL pin is pulled down to ground.

### 6.3.4 Overtemperature Protection (OTP)

LMG1025-Q1 features overtemperature protection (OTP) function by having a rising edge trigger point at around 170°C of junction temperature. With a hysteresis of 20°C, the device can restart to operate when junction temperature is below 150°C.

## 6.4 Device Functional Modes

The device will operate in following mode when not in UVLO state.

**表 6-1. Truth Table**

IN-	IN+	OUTH	OUTL
L	L	Open	L
L	H	H	Open
H	L	Open	L
H	H	Open	L

## 7 Application and Implementation

### 注

以下のアプリケーション情報は、TI の製品仕様に含まれるものではなく、TI ではその正確性または完全性を保証いたしません。個々の目的に対する製品の適合性については、お客様の責任で判断していただくこととなります。お客様は自身の設計実装を検証しテストすることで、システムの機能を確認する必要があります。

### 7.1 Application Information

To operate GaN FET or MOSFET at very high switching frequencies and to reduce associated switching losses, a powerful gate driver is employed between the PWM output of controller and the gate of the GaN transistor. Also, gate drivers are indispensable when the outputs of the PWM controller do not meet the voltage or current levels needed to directly drive the gates of the switching devices. With the advent of digital power, this situation is often encountered because the PWM signal from the digital controller is often a 3.3-V logic signal, which cannot effectively turn on a power switch. A level-shift circuit is needed to boost the 3.3-V signal to the gate-drive voltage (such as 5 V) in order to fully turn on the power device and minimize conduction losses.

Gate drivers effectively provide the buffer-drive functions. Gate drivers also address other needs such as minimizing the effect of high-frequency switching noise (by placing the high-current driver IC physically close to the power switch), reducing power dissipation and thermal stress in controllers by moving gate charge power losses from the controller into the driver.

The LMG1025-Q1 is a high frequency low-side gate driver for enhancement mode GaN FETs and Si FETs in a single ended configuration. The split-gate outputs with strong source and sink capability provides flexibility to adjust the turn-on and turn-off strength independently. As a low side driver, LMG1025-Q1 can be used in a variety of applications, including different power converters, LiDAR, time-of-flight (ToF) laser drivers, class-E wireless chargers, synchronous rectifiers, and augmented reality devices. LMG1025-Q1 can also be used as a high frequency low current laser diode driver, or as a signal buffer with very fast rise/fall time.

### 7.2 Typical Application

The LMG1025-Q1 is designed to be used with a single low-side, ground-referenced GaN or logic-level FET, as shown in [図 7-1](#). Independent gate drive resistors, R1 and R2, are used to independently control the turnon and turnoff drive strengths, respectively. For fast and strong turnoff, R2 can be shorted and OUTL directly connected to the transistor's gate. For symmetric drive strengths, it is acceptable to short OUTH and OUTL and use a single gate-drive resistor. The care should be taken that the ringing on the gate of the power device or ringing on any of the gate driver pin does not exceed the recommended rating. Resistors play an important role in damping these ringing. The layout and type of gate resistor with respect to gate driver and power device is also very important.

It is strongly recommended to use at least a 2-Ω resistor at each OUTH and OUTL to avoid voltage overstress due to inductive ringing. Ringing has to be ensured to be below  $V_{DD}+0.3$  V.

For applications requiring smaller resistance, please contact the factory for guidance.

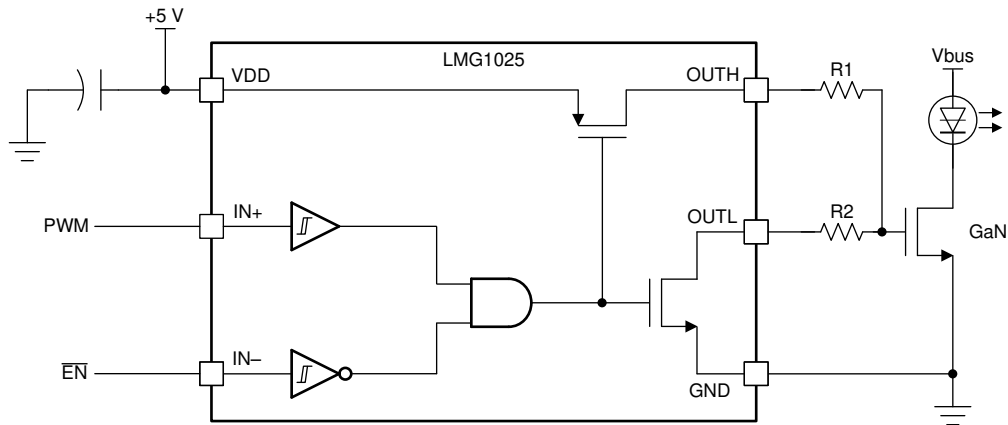

Figure 7-1. Typical Implementation of a Circuit

### 7.2.1 Design Requirements

When designing a multi-MHz (or nano-second pulse) application that incorporates the LMG1025-Q1 gate driver and GaN power FETs, some design considerations must be evaluated first to make the most appropriate selection. Among these considerations are layout optimization, circuit voltages, passive components, operating frequency, and controller selection.

### 7.2.2 Detailed Design Procedure

#### 7.2.2.1 Handling Ground Bounce

For the best switching performance and gate loop with lowest parasitics, it is recommended to connect the ground return pin of LMG1025-Q1 as close as possible to the source of the low-side FET in a low inductance manner. However, doing so can cause the ground of LMG1025-Q1 to bounce relative to the system or controller ground and lead to erroneous switching logic on the input so as mis-turn on/off on the output.

First of all, LMG1025-Q1 has input hysteresis built into the input buffers to help counteract this effect. The maximum  $di/dt$  allowed to prevent the input voltage transient from exceeding the input hysteresis is given by 式 1

$$\frac{di_s}{dt} = \frac{V_{HYST}}{L_{RS}} \quad (1)$$

where

- $L_{RS}$  is the inductance of the sense resistor,
- $V_{HYST}$  is the hysteresis of the input pin,
- and  $di/dt$  is the maximum allowed current slew rate.

For an assumed shunt resistor parasitic inductance of 0.5 nH and a minimum hysteresis of 0.5 V, the maximum slew rate is 1 A/ns. Many applications would exhibit higher current slew rates, up to the 10 A/ns range, which would make this approach impractical. The stability of this approach can be improved by using the IN- input for the PWM signal and locally tying IN+ to VDD. By using the inverting input, the transient voltage applied to the input pin reinforces the PWM signal in a positive feedback loop. While this approach would reduce the probability of false pulses or oscillation, the transient spikes due to high  $di/dt$  may overly stress the inputs to the LMG1025-Q1. A current-limiting, 100  $\Omega$  resistor can be placed right before the IN- input to limit excessive current spikes in the device.

Secondly, for moderate ground-bounce cases, a simple R-C filter can be built with a simple resistor in series with the inputs. By utilizing the input capacitance of LMG1025-Q1, the resistor could be close to its input pin. The

addition of a small capacitor on the input as supplement can also be helpful. A small time constant of the R-C filter may be enough to filter out high frequency noise. This solution is acceptable for moderate cases in applications where extra delay is acceptable and the pulse width is not extremely short such as in 1ns range.

For more extreme cases, or where no delay is tolerable while pulse width is extremely short, using a commonmode choke provides the best results.

One example application where ground-bounce is particularly challenging is when using a current sense resistor. In [Figure 7-2](#) LMG1025-Q1 ground is connected to the source of GaN FET, while the controller ground is connected to the other side of the current sense resistor as shown in [Figure 7-2](#). Due to the fast switching and very fast current slew rates, the high ground potential bounce induced by inductance of the sense resistor can disrupt the operation of the circuit or even damage the part. To prevent this, a common-mode choke can be used for IN+ and IN-, respectively. Resistors can also be added to the signal output line before LMG1025-Q1 depending on the input signal pulse width to provide additional RC filtering. [Figure 7-4](#) presents the schematic using approach A with the preferred filtering method. Approach B as shown in [Figure 7-3](#) places the current sense resistor within the gate drive loop path. In this case, the LMG1025-Q1 GND pin is connected to the signal ground, and with good ground plane connection, the ground bounce issue can be less severe than approach A. However, the inductance of the current sense resistor adds common-source inductance to the gate drive loop. The voltage generated across this parasitic inductance will subtract from the gate-drive voltage of the FET, slowing down the turnon and turnoff  $di/dt$  of the FET, or even cause mis-turn on and off. Additional gate resistance will have to be added to ensure the loop is stable and ring-free. The slower rise may negate the advantage of the fast switching of the GaN FET and may cause additional losses in the circuit. Therefore, this approach is not recommended.

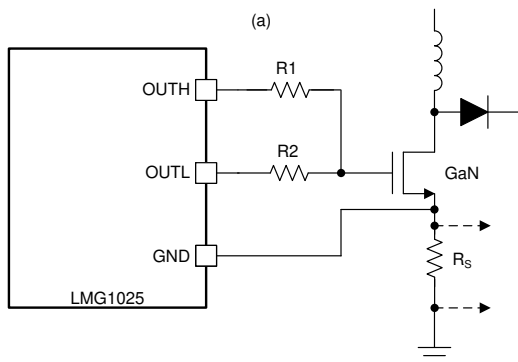

**Figure 7-2. Source Resistor Current Sense A Configuration**

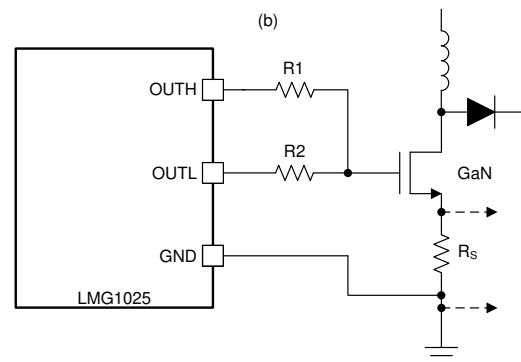

**Figure 7-3. Source Resistor Current Sense B Configuration**

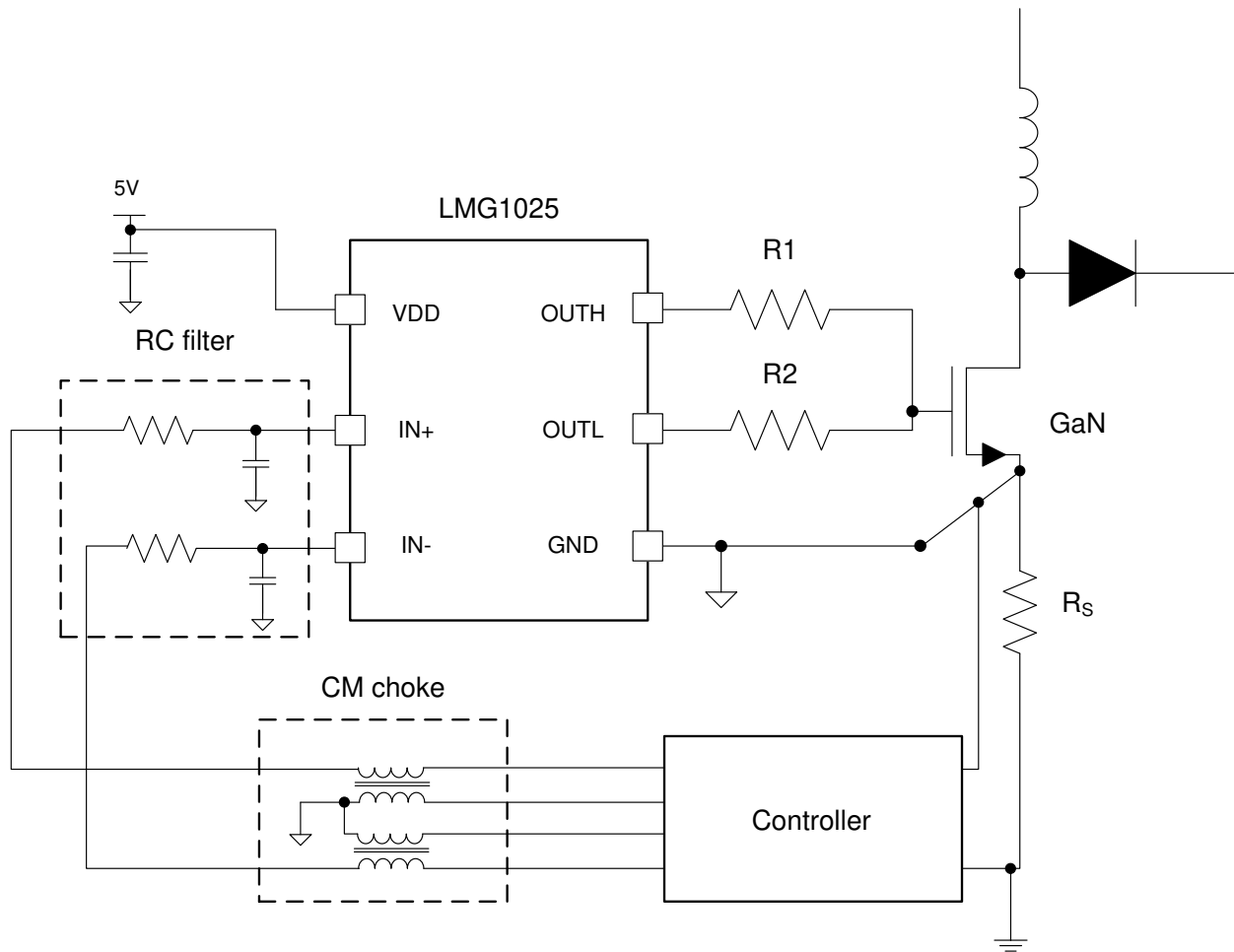

**図 7-4. Filtering For Ground Bounce Noise Handling When Using LMG1025-Q1**

### 7.2.2.2 Creating Nanosecond Pulse

LMG1025-Q1 can be used to drive pulses of nano seconds duration on to a capacitive load. LMG1025-Q1 can be driven with a equivalently short pulse on one input pin. However, this takes a sufficiently strong digital driver and careful consideration of the routing parasitics from digital output to input of LMG1025-Q1. Two inputs and included AND gate in LMG1025-Q1 provide an alternate method to create a short pulse at the LMG1025-Q1 output. Starting with both IN+ and IN- at low, taking IN+ high will cause the output to go high. Now if IN- is taken high as well, output will be pulled low. So a digital signal and its delayed version can be applied to IN+ and IN- respectively to create a pulse at the output with width corresponding to the delay between the signals, as shown in 図 7-5. The delay can be digitally controlled in the nanosecond range. This method alleviates the requirements for driving the input of LMG1025-Q1. If a separate delayed version of the digital signal is not available, an RC delay followed by a buffer can be used to derive the second signal. Optionally, if LMG1025-Q1 must be driven with a single short duration pulse, that pulse can itself be generated using another LMG1025-Q1 by the above method to meet drive requirements.



図 7-5. Timing Diagram To Create Short Pulses

### 7.2.2.3 VDD and Overshoot

Fast switching with high current is prone to ringing with parasitic inductances, including those on PCB traces. Overshoot associated with such ringing transients need to be evaluated and controlled as a part of the PCB design process to limit device stress. The parameters affecting stress are how high the overshoot is above the absolute maximum specification and the ratio of overshoot duration to the switching time period. Recommended design practice is to limit the overshoots to the absolute maximum pin voltages. This is accomplished with careful PCB layout to minimize parasitic inductances, choice of components with low ESL and addition of series resistance to limit rise times. For large overshoots, limiting the variability of the power supply may be required. For example, 0.5V of overshoot will be permissible with a maximum recommended supply of 5.25 V (5% variability); however, for larger overshoots, a supply with lower variability will be preferred.

### 7.2.2.4 Operating at Higher Frequency

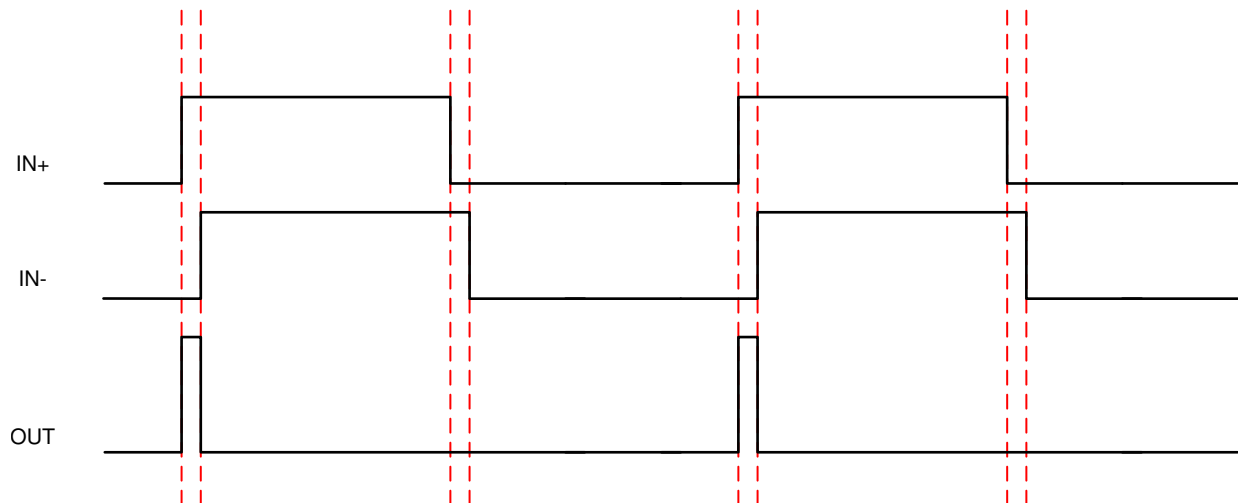
With fast rise/fall time, and capability of achieving nano-second pulse width, depending on the capacitive load condition, the operating frequency of LMG1025-Q1 can be increased in a burst manner. In conditions which requires very high frequency pulsing, a pulse train with certain period of pause between each burst can be adopted to avoid overheat of the device. This will help maintain the RMS output current similar as lower frequency operation but boost the transient frequency to very high. In addition, higher decoupling capacitance will be needed to supply high frequency charging of the capacitive load.

### 7.2.3 Application Curves

LMG1025-Q1 EVM is used to take application waveforms. This EVM has LDO, input buffer, GaN FET, and load resistor. It shows the switching performance of the LMG1025-Q1 when equivalent laser diode current is switched. 図 7-6 and 図 7-7 show VDD turn-on and turn-off delay in an application-like set-up. System designer need to make sure that these delays are acceptable in their designs. LIDAR design needs to pulse the laser diode for very short duration. 図 7-8 shows how LMG1025-Q1 can not only handle nano-second pulse at its input but also can produce a nano-second pulse at the output while driving a reasonably sized GaN FET that has 3.2nC of typical total gate charge. 図 7-8 also shows very small, e.g. less than 3 ns, rising and falling propagation delay of LMG1025-Q1. 図 7-9 shows drive strength of LMG1025-Q1. It shows how LMG1025-Q1 can achieve sub-nano second rise and fall time, which is very important for LIDAR applicatoin.



図 7-6. Startup Time



図 7-7. Shutdown Time

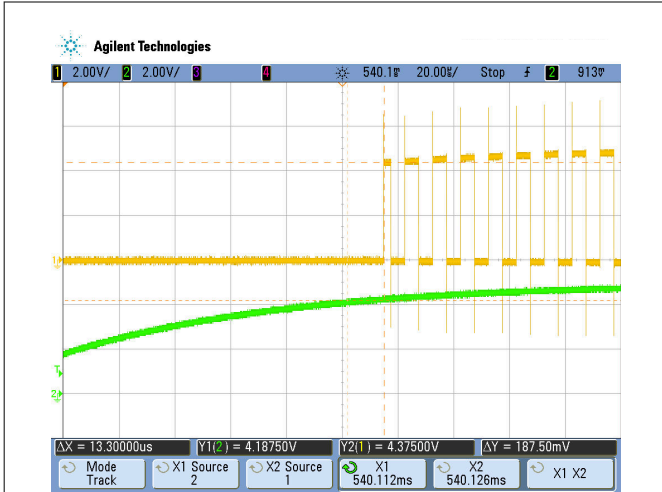

図 7-8. Input Pulse Width and Propagation Delays



図 7-9. Rise and Fall Time

## 8 Power Supply Recommendations

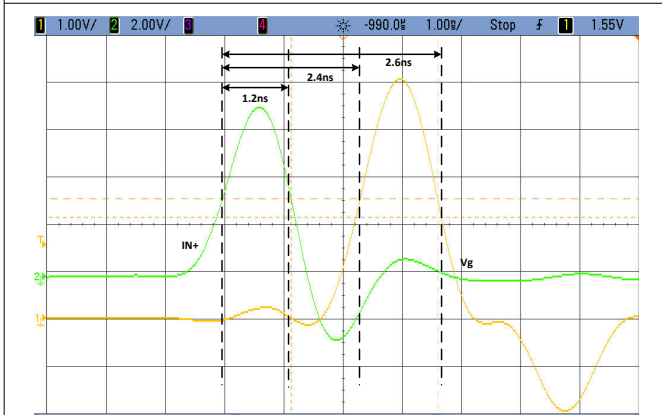
A low-ESR/ESL ceramic capacitor must be connected close to the IC, between VDD and GND pins to support the high peak current being drawn from VDD during turnon of the FETs. It is most desirable to place the VDD decoupling capacitor on the same side of the PC board as the driver. The inductance of via holes can impose excessive ringing on the IC pins.

TI recommends the use of a three-terminal capacitor connecting in shunt-through manner to achieve the lowest ESL and best transient performance. This capacitor can be placed as close as possible to the IC, while another capacitor in larger capacitance can be placed closely to the three-terminal cap to supply enough charge but with slightly lower bandwidth. As a general practice, the combination of a 0.1  $\mu\text{F}$  of 0402 or feed-through capacitor (closest to LMG1025-Q1) and a 1  $\mu\text{F}$  0603 capacitor is recommended.

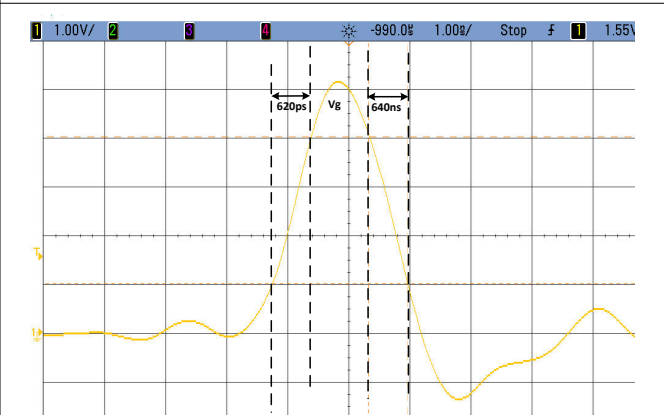

## 9 Layout

### 9.1 Layout Guidelines

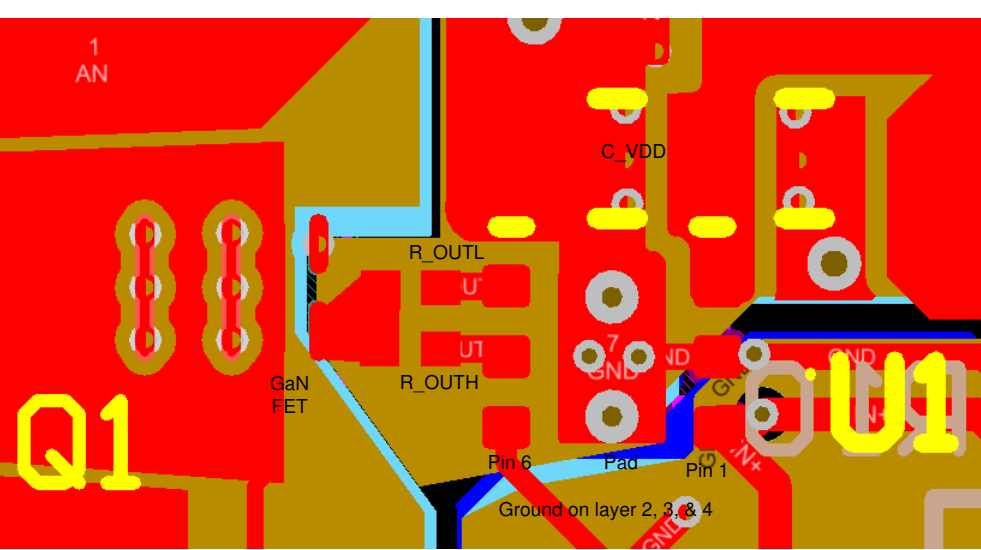
The layout of the LMG1025-Q1 is critical to its performance and functionality. The LMG1025-Q1 is available in a 2x2 DFN, which allows a low inductance connection to a FET.  9-1 shows the recommended layout of the LMG1025-Q1 with a ball-grid GaN FET.

A four-layer or higher layer count board is required to reduce the parasitic inductances of the layout to achieve suitable performance. To minimize inductance and board space, resistors and capacitors in the 0201 package should be used here. The gate drive power loss must be calculated to ensure an 0201 resistor will be able to handle the power level.

#### 9.1.1 Gate Drive Loop Inductance and Ground Connection

A compact, low-inductance gate-drive loop is essential to achieving fast switching frequencies with the LMG1025-Q1. The LMG1025-Q1 should be placed as close to the GaN FET as possible, with gate drive resistors immediately connecting OUTH and OUTL to the FET gate. Large traces need to be used to minimize resistance and parasitic inductance.

To minimize gate drive loop inductance, the source return should be on layer 2 of the PCB, immediately under the component (top) layer. Vias immediately adjacent to both the FET source and the LMG1025-Q1 GND pin connect to this plane with minimal impedance. Finally, care must be taken to connect the GND plane to the source power plane only at the FET to minimize common-source inductance and to reduce coupling to the ground plane.

#### 9.1.2 Bypass Capacitor

The VDD power terminal of the LMG1025-Q1 must be bypassed to ground immediately adjacent to the IC. The placement and value of the bypass capacitor is very critical because of the fast gate drive of the IC, . The bypass capacitor must be located on the top layer, as close as possible to the IC, and connected to both VDD and GND using large power planes. This bypass capacitor has to be at least a 0.1  $\mu\text{F}$ , up to 1  $\mu\text{F}$ , with temperature coefficient X7R or better. Recommended body types are LICC, IDC, Feed-through, and LGA. Finally, an additional 1  $\mu\text{F}$  capacitor should be placed as close to the IC as practical.

### 9.2 Layout Example

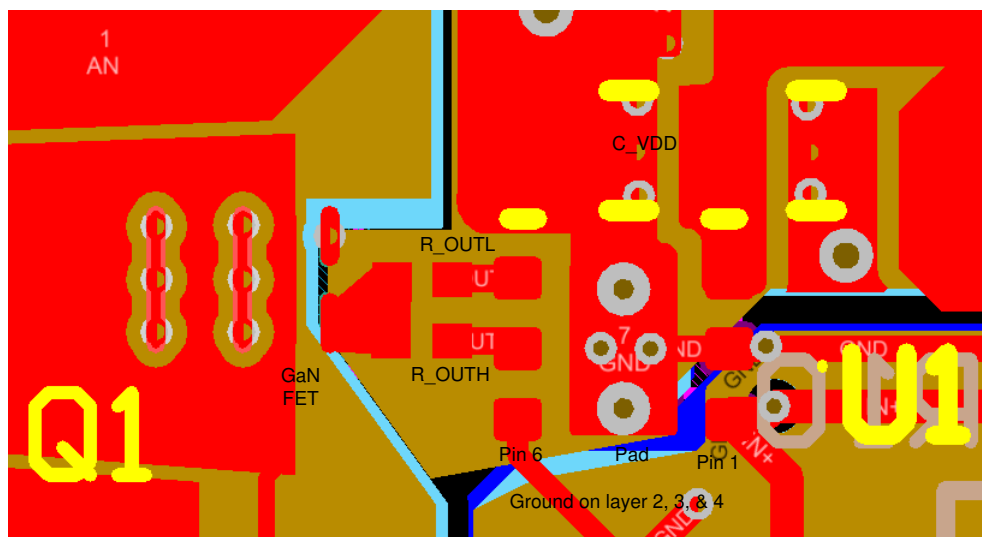

 9-1. Typical LMG1025-Q1 Layout With Ball-Grid GaN FET

## 10 Device and Documentation Support

### 10.1 Device Support

#### 10.1.1 サード・パーティ製品に関する免責事項

サード・パーティ製品またはサービスに関するテキサス・インスツルメンツの出版物は、単独またはテキサス・インスツルメンツの製品、サービスと一緒に提供される場合に関係なく、サード・パーティ製品またはサービスの適合性に関する是認、サード・パーティ製品またはサービスの是認の表明を意味するものではありません。

### 10.2 ドキュメントの更新通知を受け取る方法

ドキュメントの更新についての通知を受け取るには、[www.tij.co.jp](http://www.tij.co.jp) のデバイス製品フォルダを開いてください。[通知] をクリックして登録すると、変更されたすべての製品情報に関するダイジェストを毎週受け取ることができます。変更の詳細については、改訂されたドキュメントに含まれている改訂履歴をご覧ください。

### 10.3 サポート・リソース

テキサス・インスツルメンツ E2E™ サポート・フォーラムは、エンジニアが検証済みの回答と設計に関するヒントをエキスパートから迅速かつ直接得ることができる場所です。既存の回答を検索したり、独自の質問をしたりすることで、設計に必要な支援を迅速に得ることができます。

リンクされているコンテンツは、各寄稿者により「現状のまま」提供されるものです。これらはテキサス・インスツルメンツの仕様を構成するものではなく、必ずしもテキサス・インスツルメンツの見解を反映したものではありません。テキサス・インスツルメンツの[使用条件](#)を参照してください。

### 10.4 静電気放電に関する注意事項



この IC は、ESD によって破損する可能性があります。テキサス・インスツルメンツは、IC を取り扱う際には常に適切な注意を払うことを推奨します。正しい取り扱いおよび設置手順に従わない場合、デバイスを破損するおそれがあります。

ESD による破損は、わずかな性能低下からデバイスの完全な故障まで多岐にわたります。精密な IC の場合、パラメータがわずかに変化するだけで公表されている仕様から外れる可能性があるため、破損が発生しやすくなっています。

### 10.5 Trademarks

テキサス・インスツルメンツ E2E™ is a trademark of Texas Instruments.

すべての商標は、それぞれの所有者に帰属します。

### 10.6 用語集

[テキサス・インスツルメンツ用語集](#) この用語集には、用語や略語の一覧および定義が記載されています。

## 11 Revision History

資料番号末尾の英字は改訂を表しています。その改訂履歴は英語版に準じています。

Changes from Revision B (January 2020) to Revision C (December 2024)	Page
• Add the DRV package information.....	3
• Added the Y- axis title to <a href="#">図 5-4</a> and <a href="#">図 5-5</a> .....	6
• Changed functional block diagram pin numbers.....	8

Changes from Revision A (August 2019) to Revision B (January 2020)	Page
• マーケティング ステータスを「事前情報」から「量産データ」に変更。.....	1

## 12 Mechanical, Packaging, and Orderable Information

The following pages include mechanical, packaging, and orderable information. This information is the most current data available for the designated devices. This data is subject to change without notice and revision of this document. For browser-based versions of this data sheet, refer to the left-hand navigation.

## 重要なお知らせと免責事項

テキサス・インスツルメンツは、技術データと信頼性データ (データシートを含みます)、設計リソース (リファレンス デザインを含みます)、アプリケーションや設計に関する各種アドバイス、Web ツール、安全性情報、その他のリソースを、欠陥が存在する可能性のある「現状のまま」提供しており、商品性および特定目的に対する適合性の黙示保証、第三者の知的財産権の非侵害保証を含むいかなる保証も、明示的または黙示的にかかわらず拒否します。

これらのリソースは、テキサス・インスツルメンツ製品を使用する設計の経験を積んだ開発者への提供を意図したものです。(1) お客様のアプリケーションに適した テキサス・インスツルメンツ製品の選定、(2) お客様のアプリケーションの設計、検証、試験、(3) お客様のアプリケーションに該当する各種規格や、その他のあらゆる安全性、セキュリティ、規制、または他の要件への確実な適合に関する責任を、お客様のみが単独で負うものとします。

上記の各種リソースは、予告なく変更される可能性があります。これらのリソースは、リソースで説明されている テキサス・インスツルメンツ製品を使用するアプリケーションの開発の目的でのみ、テキサス・インスツルメンツはその使用をお客様に許諾します。これらのリソースに関して、他の目的で複製することや掲載することは禁止されています。テキサス・インスツルメンツや第三者の知的財産権のライセンスが付与されている訳ではありません。お客様は、これらのリソースを自身で使用した結果発生するあらゆる申し立て、損害、費用、損失、責任について、テキサス・インスツルメンツおよびその代理人を完全に補償するものとし、テキサス・インスツルメンツは一切の責任を拒否します。

テキサス・インスツルメンツの製品は、[テキサス・インスツルメンツの販売条件](#)、または [ti.com](https://www.ti.com) やかかる テキサス・インスツルメンツ製品の関連資料などのいずれかを通じて提供する適用可能な条項の下で提供されています。テキサス・インスツルメンツがこれらのリソースを提供することは、適用されるテキサス・インスツルメンツの保証または他の保証の放棄の拡大や変更を意味するものではありません。

お客様がいかなる追加条項または代替条項を提案した場合でも、テキサス・インスツルメンツはそれらに異議を唱え、拒否します。

郵送先住所: Texas Instruments, Post Office Box 655303, Dallas, Texas 75265

Copyright © 2024, Texas Instruments Incorporated

## PACKAGING INFORMATION

Orderable part number	Status (1)	Material type (2)	Package   Pins	Package qty   Carrier	RoHS (3)	Lead finish/ Ball material (4)	MSL rating/ Peak reflow (5)	Op temp (°C)	Part marking (6)
<a href="#">LMG1025QDEERQ1</a>	Active	Production	WSON (DEE)   6	3000   LARGE T&R	Yes	SN	Level-2-260C-1 YEAR	-40 to 125	LMG
LMG1025QDEERQ1.A	Active	Production	WSON (DEE)   6	3000   LARGE T&R	Yes	SN	Level-2-260C-1 YEAR	-40 to 125	LMG
<a href="#">LMG1025QDEETQ1</a>	Active	Production	WSON (DEE)   6	250   SMALL T&R	Yes	SN	Level-2-260C-1 YEAR	-40 to 125	LMG
LMG1025QDEETQ1.A	Active	Production	WSON (DEE)   6	250   SMALL T&R	Yes	SN	Level-2-260C-1 YEAR	-40 to 125	LMG
<a href="#">LMG1025QDRVQR1</a>	Active	Production	WSON (DRV)   6	3000   LARGE T&R	Yes	SN	Level-1-260C-UNLIM	-40 to 125	LQ25
LMG1025QDRVQR1.A	Active	Production	WSON (DRV)   6	3000   LARGE T&R	Yes	SN	Level-1-260C-UNLIM	-40 to 125	LQ25

(1) **Status:** For more details on status, see our [product life cycle](#).

(2) **Material type:** When designated, preproduction parts are prototypes/experimental devices, and are not yet approved or released for full production. Testing and final process, including without limitation quality assurance, reliability performance testing, and/or process qualification, may not yet be complete, and this item is subject to further changes or possible discontinuation. If available for ordering, purchases will be subject to an additional waiver at checkout, and are intended for early internal evaluation purposes only. These items are sold without warranties of any kind.

(3) **RoHS values:** Yes, No, RoHS Exempt. See the [TI RoHS Statement](#) for additional information and value definition.

(4) **Lead finish/Ball material:** Parts may have multiple material finish options. Finish options are separated by a vertical ruled line. Lead finish/Ball material values may wrap to two lines if the finish value exceeds the maximum column width.

(5) **MSL rating/Peak reflow:** The moisture sensitivity level ratings and peak solder (reflow) temperatures. In the event that a part has multiple moisture sensitivity ratings, only the lowest level per JEDEC standards is shown. Refer to the shipping label for the actual reflow temperature that will be used to mount the part to the printed circuit board.

(6) **Part marking:** There may be an additional marking, which relates to the logo, the lot trace code information, or the environmental category of the part.

Multiple part markings will be inside parentheses. Only one part marking contained in parentheses and separated by a "~" will appear on a part. If a line is indented then it is a continuation of the previous line and the two combined represent the entire part marking for that device.

**Important Information and Disclaimer:** The information provided on this page represents TI's knowledge and belief as of the date that it is provided. TI bases its knowledge and belief on information provided by third parties, and makes no representation or warranty as to the accuracy of such information. Efforts are underway to better integrate information from third parties. TI has taken and continues to take reasonable steps to provide representative and accurate information but may not have conducted destructive testing or chemical analysis on incoming materials and chemicals. TI and TI suppliers consider certain information to be proprietary, and thus CAS numbers and other limited information may not be available for release.

In no event shall TI's liability arising out of such information exceed the total purchase price of the TI part(s) at issue in this document sold by TI to Customer on an annual basis.



**TAPE AND REEL INFORMATION**

**QUADRANT ASSIGNMENTS FOR PIN 1 ORIENTATION IN TAPE**

\*All dimensions are nominal

Device	Package Type	Package Drawing	Pins	SPQ	Reel Diameter (mm)	Reel Width W1 (mm)	A0 (mm)	B0 (mm)	K0 (mm)	P1 (mm)	W (mm)	Pin1 Quadrant
LMG1025QDEERQ1	WSON	DEE	6	3000	180.0	8.4	2.2	2.2	1.2	4.0	8.0	Q2
LMG1025QDEETQ1	WSON	DEE	6	250	180.0	8.4	2.2	2.2	1.2	4.0	8.0	Q2
LMG1025QDRVRQ1	WSON	DRV	6	3000	180.0	8.4	2.3	2.3	1.15	4.0	8.0	Q2

**TAPE AND REEL BOX DIMENSIONS**

\*All dimensions are nominal

Device	Package Type	Package Drawing	Pins	SPQ	Length (mm)	Width (mm)	Height (mm)
LMG1025QDEERQ1	WSON	DEE	6	3000	213.0	191.0	35.0
LMG1025QDEETQ1	WSON	DEE	6	250	213.0	191.0	35.0
LMG1025QDRVRQ1	WSON	DRV	6	3000	210.0	185.0	35.0



## GENERIC PACKAGE VIEW

DRV 6

WSON - 0.8 mm max height

PLASTIC SMALL OUTLINE - NO LEAD



Images above are just a representation of the package family, actual package may vary.  
Refer to the product data sheet for package details.

4206925/F

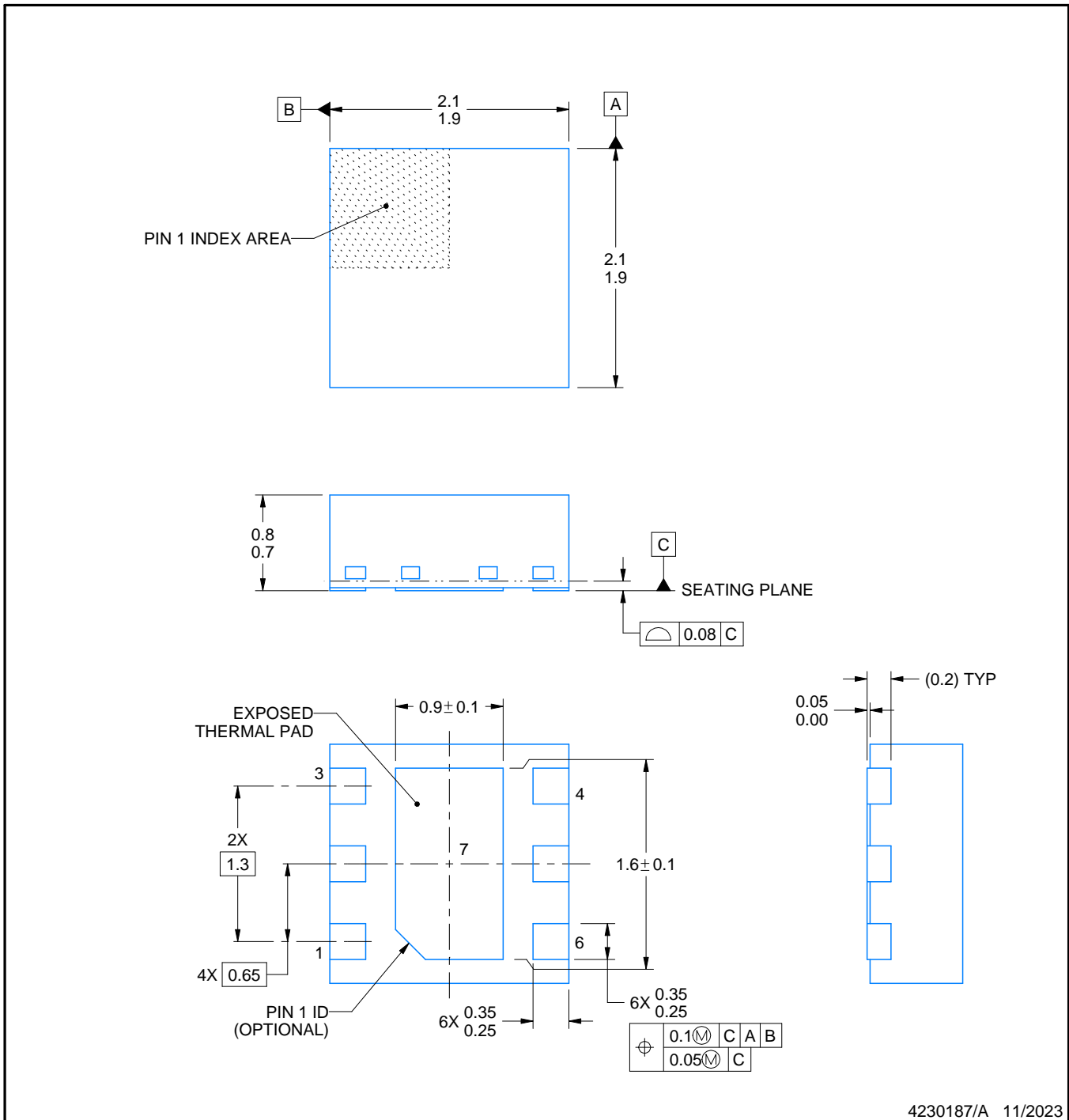
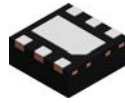

NOTES:

1. All linear dimensions are in millimeters. Any dimensions in parenthesis are for reference only. Dimensioning and tolerancing per ASME Y14.5M.
2. This drawing is subject to change without notice.

# EXAMPLE BOARD LAYOUT

DRV0006E

WSON - 0.8 mm max height

PLASTIC SMALL OUTLINE - NO LEAD

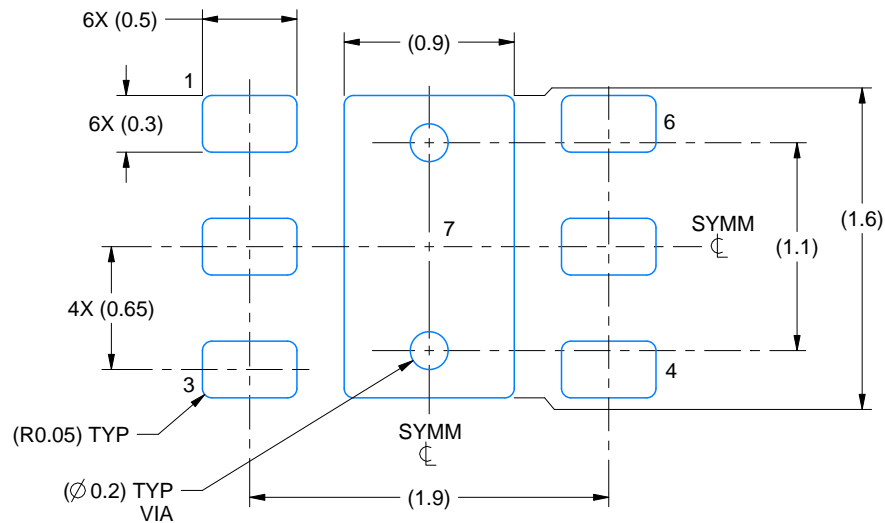

LAND PATTERN EXAMPLE  
EXPOSED METAL SHOWN  
SCALE:25X

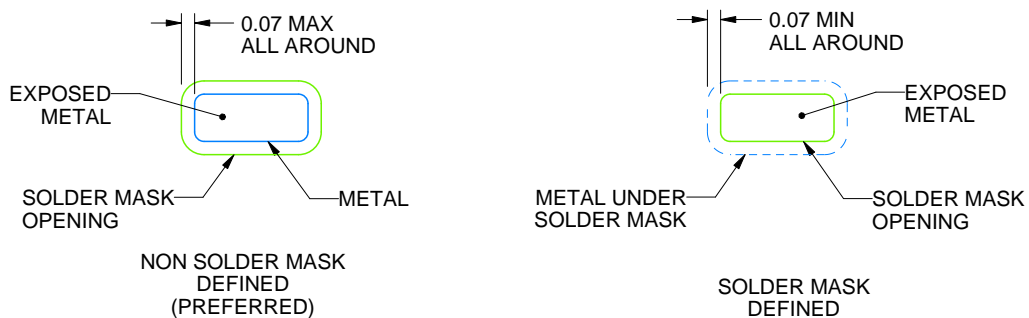

SOLDER MASK DETAILS

4230187/A 11/2023

NOTES: (continued)

3. For more information, see Texas Instruments literature number SLUA271 ([www.ti.com/lit/slua271](http://www.ti.com/lit/slua271)).
4. Vias are optional depending on application, refer to device data sheet. If any vias are implemented, refer to their locations shown on this view. It is recommended that vias under paste be filled, plugged or tented.

# EXAMPLE STENCIL DESIGN

DRV0006E

WSON - 0.8 mm max height

PLASTIC SMALL OUTLINE - NO LEAD

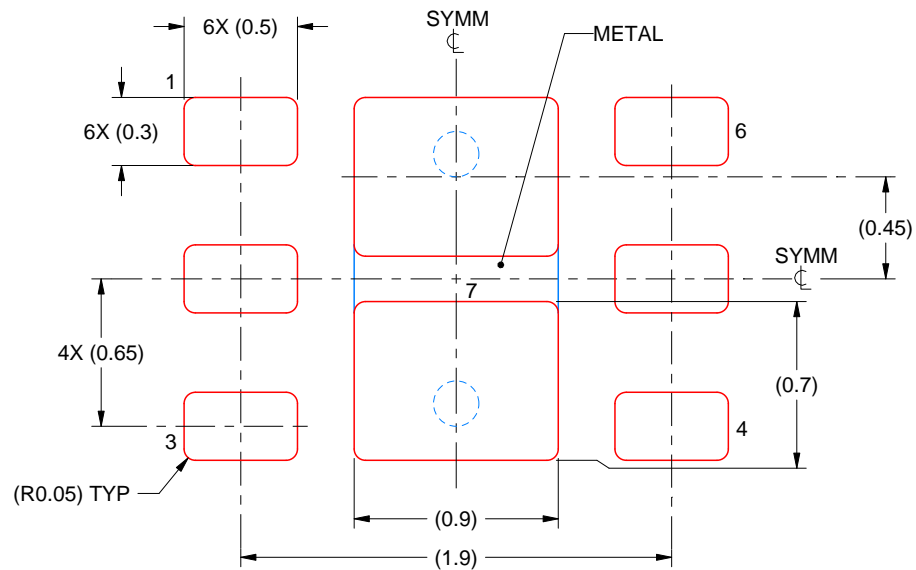

SOLDER PASTE EXAMPLE  
BASED ON 0.125 mm THICK STENCIL

EXPOSED PAD #7:  
88% PRINTED SOLDER COVERAGE BY AREA UNDER PACKAGE  
SCALE:30X

4230187/A 11/2023

NOTES: (continued)

5. Laser cutting apertures with trapezoidal walls and rounded corners may offer better paste release. IPC-7525 may have alternate design recommendations.

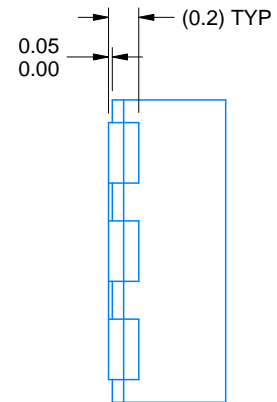
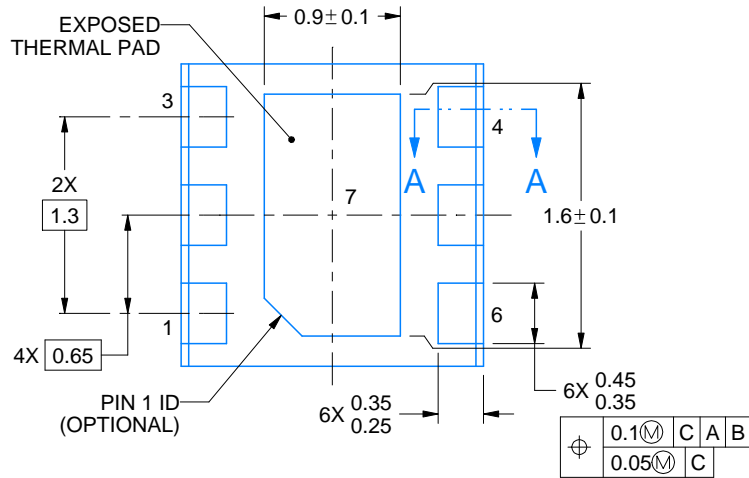
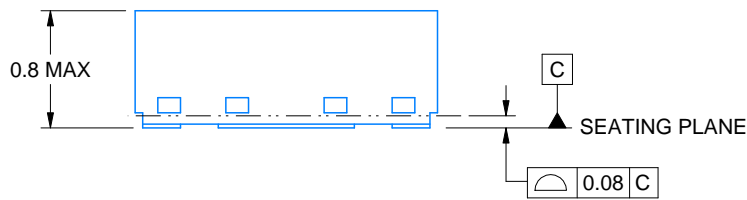
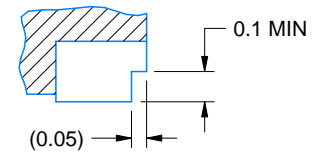
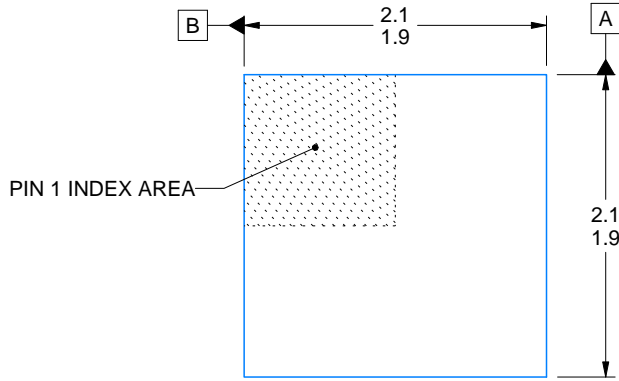
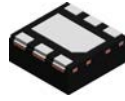

4219364/A 01/2019

NOTES:

1. All linear dimensions are in millimeters. Any dimensions in parenthesis are for reference only. Dimensioning and tolerancing per ASME Y14.5M.
2. This drawing is subject to change without notice.

# EXAMPLE BOARD LAYOUT

DEE0006A

WSON - 0.8 mm max height

PLASTIC SMALL OUTLINE - NO LEAD

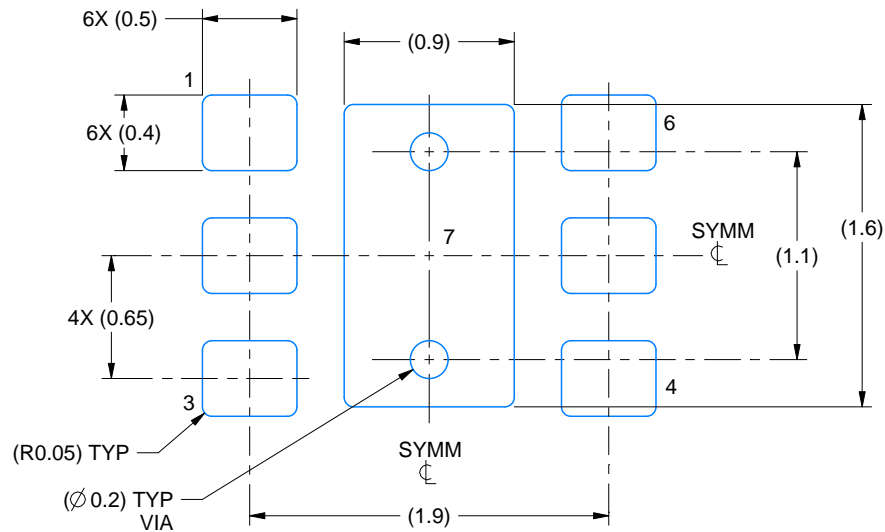

LAND PATTERN EXAMPLE  
EXPOSED METAL SHOWN  
SCALE:25X

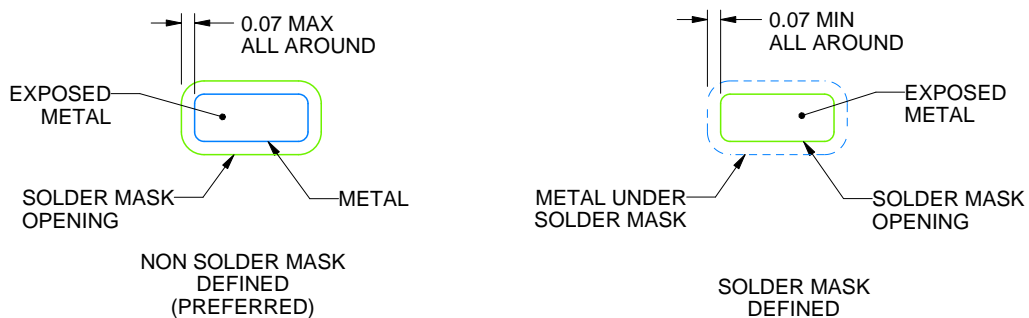

SOLDER MASK DETAILS

4219364/A 01/2019

NOTES: (continued)

3. For more information, see Texas Instruments literature number SLUA271 ([www.ti.com/lit/sluea271](http://www.ti.com/lit/sluea271)).
4. Vias are optional depending on application, refer to device data sheet. If any vias are implemented, refer to their locations shown on this view. It is recommended that vias under paste be filled, plugged or tented.

# EXAMPLE STENCIL DESIGN

DEE0006A

WSON - 0.8 mm max height

PLASTIC SMALL OUTLINE - NO LEAD

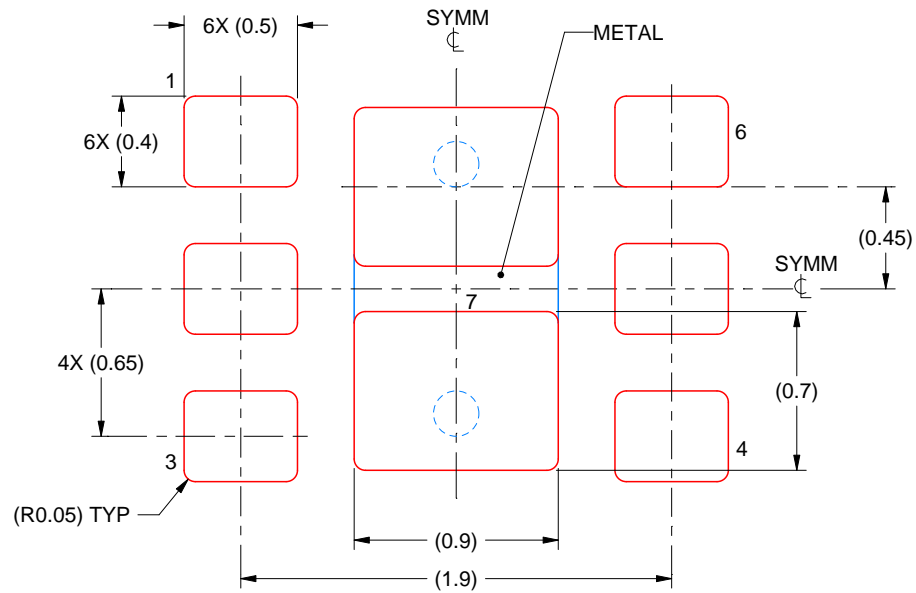

SOLDER PASTE EXAMPLE  
BASED ON 0.125 mm THICK STENCIL

EXPOSED PAD #7:  
88% PRINTED SOLDER COVERAGE BY AREA UNDER PACKAGE  
SCALE:30X

4219364/A 01/2019

NOTES: (continued)

5. Laser cutting apertures with trapezoidal walls and rounded corners may offer better paste release. IPC-7525 may have alternate design recommendations.

## 重要なお知らせと免責事項

テキサス・インスツルメンツは、技術データと信頼性データ(データシートを含みます)、設計リソース(リファレンス デザインを含みます)、アプリケーションや設計に関する各種アドバイス、Web ツール、安全性情報、その他のリソースを、欠陥が存在する可能性のある「現状のまま」提供しており、商品性および特定目的に対する適合性の黙示保証、第三者の知的財産権の非侵害保証を含むいかなる保証も、明示的または黙示的にかかわらず拒否します。

これらのリソースは、テキサス・インスツルメンツ製品を使用する設計の経験を積んだ開発者への提供を意図したものです。(1) お客様のアプリケーションに適したテキサス・インスツルメンツ製品の選定、(2) お客様のアプリケーションの設計、検証、試験、(3) お客様のアプリケーションに該当する各種規格や、その他のあらゆる安全性、セキュリティ、規制、または他の要件への確実な適合に関する責任を、お客様のみが単独で負うものとし、ます。

上記の各種リソースは、予告なく変更される可能性があります。これらのリソースは、リソースで説明されているテキサス・インスツルメンツ製品を使用するアプリケーションの開発の目的でのみ、テキサス・インスツルメンツはその使用をお客様に許諾します。これらのリソースに関して、他の目的で複製することや掲載することは禁止されています。テキサス・インスツルメンツや第三者の知的財産権のライセンスが付与されている訳ではありません。お客様は、これらのリソースを自身で使用した結果発生するあらゆる申し立て、損害、費用、損失、責任について、テキサス・インスツルメンツおよびその代理人を完全に補償するものとし、テキサス・インスツルメンツは一切の責任を拒否します。

テキサス・インスツルメンツの製品は、[テキサス・インスツルメンツの販売条件](#)、または [ti.com](https://www.ti.com) やかかるテキサス・インスツルメンツ製品の関連資料などのいずれかを通じて提供する適用可能な条項の下で提供されています。テキサス・インスツルメンツがこれらのリソースを提供することは、適用されるテキサス・インスツルメンツの保証または他の保証の放棄の拡大や変更を意味するものではありません。

お客様がいかなる追加条項または代替条項を提案した場合でも、テキサス・インスツルメンツはそれらに異議を唱え、拒否します。

郵送先住所：Texas Instruments, Post Office Box 655303, Dallas, Texas 75265  
Copyright © 2025, Texas Instruments Incorporated