

ISO776x-Q1 高速で堅牢な EMC 強化型 6 チャンネル デジタル アイソレータ

1 特長

- 車載アプリケーション認定済み
- 以下の結果で AEC-Q100 認定済み:
 - デバイス温度グレード 1: -40°C ~ +125°C の周囲温度範囲
 - デバイス HBM ESD 分類レベル 3A
 - デバイス CDM ESD 分類レベル C6
- 機能安全対応
 - 機能安全システムの設計に役立つ資料を利用可能: [ISO7760-Q1](#)、[ISO7761-Q1](#)、[ISO7762-Q1](#)、[ISO7763-Q1](#)
- 100Mbps のデータレート
- 堅牢な絶縁バリア:
 - 推定寿命: 30 年超
 - 最高 5000V_{RMS} の絶縁定格
 - 最高 12.8kV のサージ耐量
 - CMTI: ±100kV/μs (標準値)
- 幅広い電源電圧範囲: 2.25V ~ 5.5V
- 2.25V から 5.5V への電圧レベル変換
- デフォルト出力が HIGH (ISO776x) と LOW (ISO776xF) のオプション
- 低い消費電力: 1Mbps でチャンネルごとに標準値 1.4mA
- 小さい伝搬遅延: 11ns (標準値、5V 時)
- 堅牢な電磁環境適合性 (EMC):
 - システムレベルでの ESD、EFT、サージ耐性
 - 絶縁バリアの両側で ±8kV の IEC 61000-4-2 接触放電保護
 - 低い放射
- Wide-SOIC (DW-16) および SSOP (DBQ-16) のパッケージ オプション
- 安全関連認証:
 - DIN EN IEC 60747-17 (VDE 0884-17) に準拠した強化絶縁
 - UL 1577 部品認定プログラム
 - IEC 62368-1 および IEC 60601-1 準拠の CSA 認定
 - GB4943.1 準拠の CQC 認定
 - EN 62368-1 および EN 61010-1 に従った TUV 認定

2 アプリケーション

- ハイブリッド、電気自動車、およびパワー・トレイン・システム (EV/HEV)
 - バッテリー・マネジメント・システム (BMS)
 - オンボード・チャージャ

- トラクション・インバータ
- DC/DC コンバータ
- スタータ / 発電機

3 概要

ISO776x-Q1 デバイスは、高性能の 6 チャンネル デジタル アイソレータであり、UL 1577 準拠で 5000V_{RMS} (DW パッケージ) および 3000V_{RMS} (DBQ パッケージ) の絶縁定格を備えています。このファミリのデバイスは、VDE、CSA、TUV、CQC についても認定済みです。

ISO776x-Q1 ファミリのデバイスは電磁気耐性が高く、放射が低く、低消費電力を実現し、CMOS または LVCMOS デジタル I/O が絶縁されています。それぞれの絶縁チャンネルにはロジック入力およびロジック出力バッファがあり、二重の容量性二酸化ケイ素 (SiO₂) の絶縁バリアによって分離されています。ISO776x-Q1 ファミリのデバイスは、6 つのチャンネルすべてが同じ方向、または 1、2、3 チャンネルが逆方向で他のチャンネルが順方向など、可能なすべてのピン構成で利用可能です。入力電力または入力信号が失われた場合のデフォルト出力は、接尾辞 F のないデバイスでは High、接尾辞 F のあるデバイスでは Low になります。詳細は「[デバイスの機能モード](#)」のセクションを参照してください。

パッケージ情報

部品番号	パッケージ ⁽¹⁾	本体サイズ (公称)	パッケージサイズ ⁽²⁾
ISO7760-Q1 ISO7761-Q1	SOIC (DW, 16)	10.30mm × 7.50mm	10.3mm × 10.30mm
ISO7762-Q1 ISO7763-Q1	SSOP (DBQ) (16)	4.90mm × 3.90mm	4.90mm × 6.00mm

- 詳細については、[セクション 13](#) を参照してください。
- パッケージサイズ (長さ × 幅) は公称値であり、該当する場合はピンも含まれます。

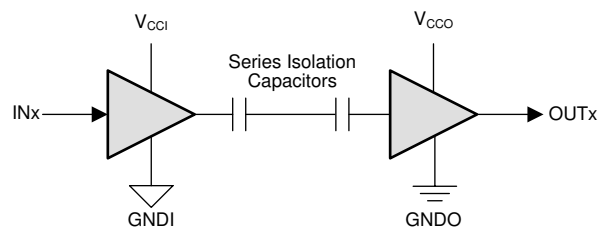

Copyright © 2016, Texas Instruments Incorporated

V_{CCI} = 入力 V_{CC}、V_{CCO} = 出力 V_{CC}
 GNDI = 入力グラウンド、GNDO = 出力グラウンド

概略回路図



Table of Contents

1 特長	1	6.19 Typical Characteristics.....	23
2 アプリケーション	1	7 Detailed Description	27
3 概要	1	7.1 Overview.....	27
4 概要 (続き)	2	7.2 Functional Block Diagram.....	27
5 Pin Configuration and Functions	3	7.3 Feature Description.....	28
6 Specifications	6	7.4 Device Functional Modes.....	29
6.1 Absolute Maximum Ratings.....	6	8 Application and Implementation	30
6.2 ESD Ratings.....	6	8.1 Application Information.....	30
6.3 Recommended Operating Conditions.....	7	8.2 Typical Application.....	30
6.4 Thermal Information.....	8	9 Power Supply Recommendations	33
6.5 Power Ratings.....	8	10 Layout	34
6.6 Insulation Specifications.....	9	10.1 Layout Guidelines.....	34
6.7 Safety-Related Certifications.....	11	10.2 Layout Example.....	34
6.8 Safety Limiting Values.....	11	11 Device and Documentation Support	35
6.9 Electrical Characteristics—5-V Supply.....	13	11.1 Documentation Support.....	35
6.10 Supply Current Characteristics—5-V Supply.....	13	11.2 Related Links.....	35
6.11 Electrical Characteristics—3.3-V Supply.....	15	11.3 Receiving Notification of Documentation Updates..	35
6.12 Supply Current Characteristics—3.3-V Supply.....	15	11.4 サポート・リソース.....	35
6.13 Electrical Characteristics—2.5-V Supply.....	17	11.5 Trademarks.....	35
6.14 Supply Current Characteristics—2.5-V Supply.....	17	11.6 静電気放電に関する注意事項.....	35
6.15 Switching Characteristics—5-V Supply.....	19	11.7 用語集.....	36
6.16 Switching Characteristics—3.3-V Supply.....	20	12 Revision History	36
6.17 Switching Characteristics—2.5-V Supply.....	21	13 Mechanical, Packaging, and Orderable Information	36
6.18 Insulation Characteristics Curves.....	22		

4 概要 (続き)

絶縁電源と組み合わせて使用することで、このデバイス・ファミリーは、データ・バス (たとえば CAN、LIN など) または他の回路からのノイズ電流がローカル・グラウンドに入り込み、敏感な回路に干渉や損傷を引き起こすことを防ぐのに役立ちます。革新的なチップ設計およびレイアウト技法により、ISO776x-Q1 ファミリのデバイスは電磁環境適合性が大幅に強化されているため、システム・レベルの ESD、EFT、サージ、および放射に関するコンプライアンスを容易に達成できます。ISO776x-Q1 ファミリのデバイスは、16 ピンの SOIC および SSOP パッケージで供給されます。

5 Pin Configuration and Functions

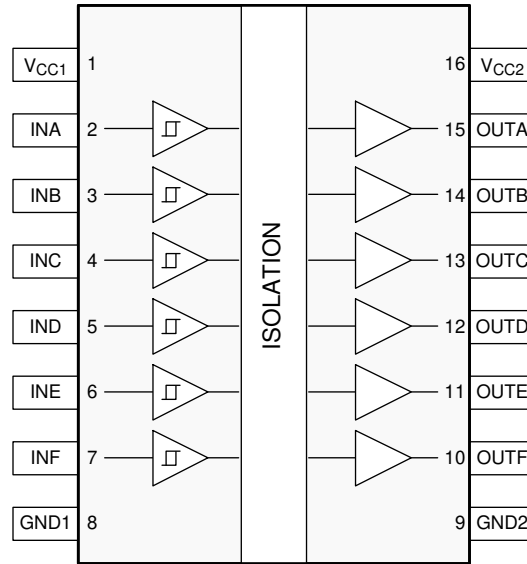

 **5-1. ISO7760-Q1 DW and DBQ Packages 16-Pin SOIC and SSOP Top View**

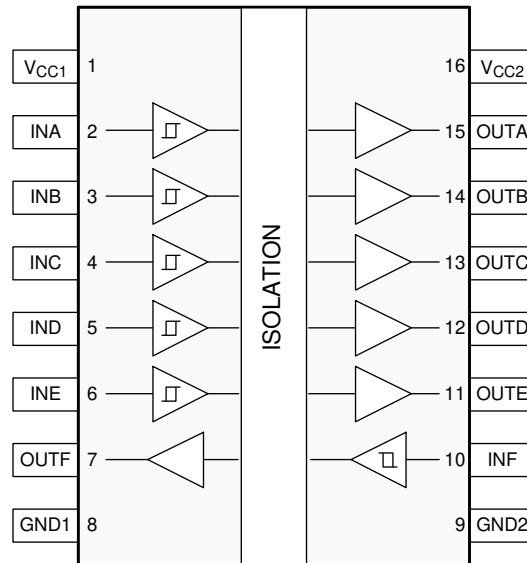

 **5-2. ISO7761-Q1 DW and DBQ Packages 16-Pin SOIC and SSOP Top View**



図 5-3. ISO7762-Q1 DW and DBQ Packages 16-Pin SOIC and SSOP Top View



図 5-4. ISO7763-Q1 DW and DBQ Packages 16-Pin SOIC and SSOP Top View

表 5-1. Pin Functions

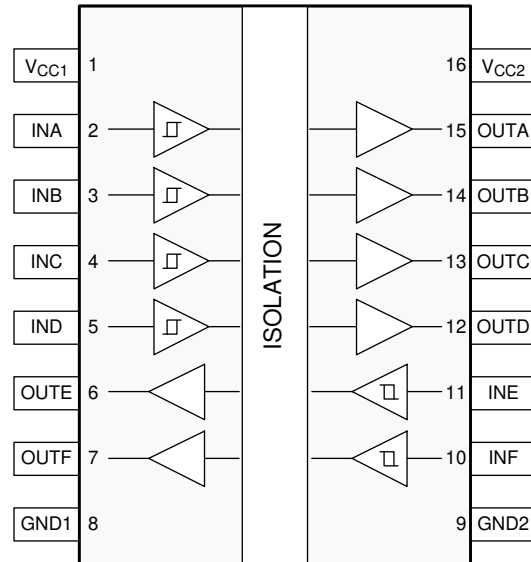
NAME	PIN				Type	DESCRIPTION
	NO.					
	ISO7760-Q1	ISO7761-Q1	ISO7762-Q1	ISO7763-Q1		
GND1	8	8	8	8	—	Ground connection for V _{CC1}
GND2	9	9	9	9	—	Ground connection for V _{CC2}
INA	2	2	2	2	I	Input, channel A
INB	3	3	3	3	I	Input, channel B
INC	4	4	4	4	I	Input, channel C
IND	5	5	5	12	I	Input, channel D
INE	6	6	11	11	I	Input, channel E
INF	7	10	10	10	I	Input, channel F
OUTA	15	15	15	15	O	Output, channel A
OUTB	14	14	14	14	O	Output, channel B
OUTC	13	13	13	13	O	Output, channel C
OUTD	12	12	12	5	O	Output, channel D
OUTE	11	11	6	6	O	Output, channel E
OUTF	10	7	7	7	O	Output, channel F
V _{CC1}	1	1	1	1	—	Power supply, side 1
V _{CC2}	16	16	16	16	—	Power supply, side 2

6 Specifications

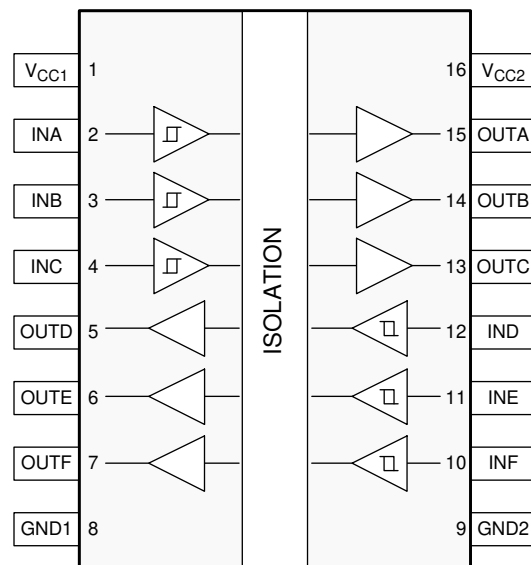
6.1 Absolute Maximum Ratings

See⁽¹⁾

		MIN	MAX	UNIT
V _{CC1} , V _{CC2}	Supply voltage ⁽²⁾	-0.5	6	V
V	Voltage at INx, OUTx	-0.5	V _{CCx} + 0.5 ⁽³⁾	V
I _o	Output current	-15	15	mA
T _J	Junction temperature		150	°C
T _{stg}	Storage temperature	-65	150	°C

- (1) Stresses beyond those listed under Absolute Maximum Ratings may cause permanent damage to the device. These are stress ratings only, which do not imply functional operation of the device at these or any other conditions beyond those indicated under Recommended Operating Conditions. Exposure to absolute-maximum-rated conditions for extended periods may affect device reliability.
- (2) All voltage values except differential I/O bus voltages are with respect to the local ground terminal (GND1 or GND2) and are peak voltage values
- (3) Maximum voltage must not exceed 6 V.

6.2 ESD Ratings

(1)

		VALUE	UNIT
V _(ESD)	Electrostatic discharge	Human body model (HBM), per AEC Q100-002 ⁽¹⁾	±6000 V
		Charged device model (CDM), per AEC Q100-011	
		Contact discharge per IEC 61000-4-2; Isolation barrier withstand test ^{(2) (3)}	±8000 V

- (1) AEC Q100-002 indicates that HBM stressing shall be in accordance with the ANSI/ESDA/JEDEC JS-001 specification.
- (2) IEC ESD strike is applied across the barrier with all pins on each side tied together creating a two-terminal device.
- (3) Testing is carried out in air or oil to determine the intrinsic contact discharge capability of the device.

6.3 Recommended Operating Conditions

		MIN	NOM	MAX	UNIT
V_{CC1}, V_{CC2}	Supply Voltage	2.25		5.5	V
$V_{CC} (UVLO+)$	UVLO threshold when supply voltage is rising		2	2.25	V
$V_{CC} (UVLO-)$	UVLO threshold when supply voltage is falling	1.7	1.8		V
$V_{HYS} (UVLO)$	Supply voltage UVLO hysteresis	100	200		mV
I_{OH}	High level output current	$V_{CCO}^{(1)} = 5\text{ V}$		-4	mA
		$V_{CCO} = 3.3\text{ V}$		-2	
		$V_{CCO} = 2.5\text{ V}$		-1	
I_{OL}	Low level output current	$V_{CCO} = 5\text{ V}$		4	mA
		$V_{CCO} = 3.3\text{ V}$		2	
		$V_{CCO} = 2.5\text{ V}$		1	
V_{IH}	High level Input voltage	$0.7 \times V_{CCI}^{(1)}$		V_{CCI}	V
V_{IL}	Low level Input voltage	0		$0.3 \times V_{CCI}$	V
$DR^{(2)}$	Data Rate	0		100	Mbps
T_A	Ambient temperature	-55	25	125	°C

(1) V_{CCI} = Input-side V_{CC} ; V_{CCO} = Output-side V_{CC}

(2) 100 Mbps is the maximum specified data rate, although higher data rates are possible.

6.4 Thermal Information

THERMAL METRIC ⁽¹⁾		ISO776x		UNIT
		DW (SOIC)	DBQ (SSOP)	
		16 PINS	16 PINS	
$R_{\theta JA}$	Junction-to-ambient thermal resistance	60.3	86.5	°C/W
$R_{\theta JC(top)}$	Junction-to-case (top) thermal resistance	24.0	26.9	°C/W
$R_{\theta JB}$	Junction-to-board thermal resistance	29.3	36.6	°C/W
ψ_{JT}	Junction-to-top characterization parameter	3.3	1.7	°C/W
ψ_{JB}	Junction-to-board characterization parameter	28.7	36.1	°C/W
$R_{\theta JC(bot)}$	Junction-to-case (bottom) thermal resistance	n/a	n/a	°C/W

(1) For more information about traditional and new thermal metrics, see the [no.](#)

6.5 Power Ratings

PARAMETER		TEST CONDITIONS	MIN	TYP	MAX	UNIT
ISO7760						
P_D	Maximum power dissipation (both sides)	$V_{CC1} = V_{CC2} = 5.5\text{ V}$, $T_J = 150^\circ\text{C}$, $C_L = 15\text{ pF}$, Input a 50-MHz 50% duty cycle square wave			314	mW
P_{D1}	Maximum power dissipation (side-1)				55	mW
P_{D2}	Maximum power dissipation (side-2)				259	mW
ISO7761						
P_D	Maximum power dissipation (both sides)	$V_{CC1} = V_{CC2} = 5.5\text{ V}$, $T_J = 150^\circ\text{C}$, $C_L = 15\text{ pF}$, Input a 50-MHz 50% duty cycle square wave			314	mW
P_{D1}	Maximum power dissipation (side-1)				88	mW
P_{D2}	Maximum power dissipation (side-2)				226	mW
ISO7762						
P_D	Maximum power dissipation (both sides)	$V_{CC1} = V_{CC2} = 5.5\text{ V}$, $T_J = 150^\circ\text{C}$, $C_L = 15\text{ pF}$, Input a 50-MHz 50% duty cycle square wave			314	mW
P_{D1}	Maximum power dissipation (side-1)				122	mW
P_{D2}	Maximum power dissipation (side-2)				192	mW
ISO7763						
P_D	Maximum power dissipation (both sides)	$V_{CC1} = V_{CC2} = 5.5\text{ V}$, $T_J = 150^\circ\text{C}$, $C_L = 15\text{ pF}$, Input a 50-MHz 50% duty cycle square wave			314	mW
P_{D1}	Maximum power dissipation (side-1)				157	mW
P_{D2}	Maximum power dissipation (side-2)				157	mW

6.6 Insulation Specifications

PARAMETER		TEST CONDITIONS	VALUE		UNIT
			DW-16	DBQ-16	
CLR	External clearance ⁽¹⁾	Shortest terminal-to-terminal distance through air	>8	>3.7	mm
CPG	External creepage ⁽¹⁾	Shortest terminal-to-terminal distance across the package surface	>8	>3.7	mm
DTI	Distance through the insulation	Minimum internal gap (internal clearance)	>17	>17	μm
CTI	Comparative tracking index	DIN EN 60112 (VDE 0303-11); IEC 60112; UL 746A	>600	>600	V
	Material group	According to IEC 60664-1	I	I	
	Overvoltage category per IEC 60664-1	Rated mains voltage ≤ 150 V _{RMS}	I-IV	I-IV	
		Rated mains voltage ≤ 300 V _{RMS}	I-IV	I-III	
		Rated mains voltage ≤ 600 V _{RMS}	I-IV	n/a	
		Rated mains voltage ≤ 1000 V _{RMS}	I-III	n/a	
DIN EN IEC 60747-17 (VDE 0884-17)⁽²⁾					
V _{IORM}	Maximum repetitive peak isolation voltage	AC voltage (bipolar)	2121	566	V _{PK}
V _{IOWM}	Maximum working isolation voltage	AC voltage; Time dependent dielectric breakdown (TDDb) test; See 8-7	1500	400	V _{RMS}
		DC voltage	2121	566	V _{DC}
V _{IOTM}	Maximum transient isolation voltage	V _{TEST} = V _{IOTM} , t = 60 s (qualification); V _{TEST} = 1.2 x V _{IOTM} , t = 1 s (100% production)	8000	4242	V _{PK}
V _{IMP}	Maximum impulse voltage ⁽³⁾	Tested in air, 1.2/50-μs waveform per IEC 62368-1	8000	4000	V _{PK}
V _{IOSM}	Maximum surge isolation voltage ⁽⁴⁾	V _{IOSM} ≥ 1.3 x V _{IMP} ; Tested in oil (qualification test), 1.2/50-μs waveform per IEC 62368-1	12800	10000	V _{PK}
q _{pd}	Apparent charge ⁽⁵⁾	Method a, After Input-output safety test subgroup 2/3, V _{ini} = V _{IOTM} , t _{ini} = 60 s; V _{pd(m)} = 1.2 x V _{IORM} , t _m = 10 s	≤5	≤5	pC
		Method a, After environmental tests subgroup 1, V _{ini} = V _{IOTM} , t _{ini} = 60 s; V _{pd(m)} = 1.6 x V _{IORM} , t _m = 10 s	≤5	≤5	
		Method b: At routine test (100% production) and preconditioning (type test); V _{ini} = 1.2 x V _{IOTM} , t _{ini} = 1 s; V _{pd(m)} = 1.875 x V _{IORM} , t _m = 1 s (method b1) or V _{pd(m)} = V _{ini} , t _m = t _{ini} (method b2)	≤5	≤5	
C _{IO}	Barrier capacitance, input to output ⁽⁶⁾	V _{IO} = 0.4 x sin (2πft), f = 1 MHz	~1.1	~0.9	pF
R _{IO}	Isolation resistance ⁽⁶⁾	V _{IO} = 500 V, T _A = 25°C	>10 ¹²	>10 ¹²	Ω
		V _{IO} = 500 V, 100°C ≤ T _A ≤ 125°C	>10 ¹¹	>10 ¹¹	
		V _{IO} = 500 V, T _S = 150°C	>10 ⁹	>10 ⁹	
	Pollution degree		2	2	
	Climatic category		55/125/ 21	55/125/ 21	
UL 1577					
V _{ISO}	Maximum withstanding isolation voltage	V _{TEST} = V _{ISO} , t = 60 s (qualification), V _{TEST} = 1.2 x V _{ISO} , t = 1 s (100% production)	5000	3000	V _{RMS}

- (1) Creepage and clearance requirements should be applied according to the specific equipment isolation standards of an application. Care should be taken to maintain the creepage and clearance distance of a board design to ensure that the mounting pads of the isolator on the printed-circuit board do not reduce this distance. Creepage and clearance on a printed-circuit board become equal in certain cases. Techniques such as inserting grooves and/or ribs on a printed-circuit board are used to help increase these specifications.

- (2) This coupler is suitable for *safe electrical insulation* only within the safety ratings. Compliance with the safety ratings shall be ensured by means of suitable protective circuits.
- (3) Testing is carried out in air to determine the surge immunity of the package
- (4) Testing is carried out in oil to determine the intrinsic surge immunity of the isolation barrier.
- (5) Apparent charge is electrical discharge caused by a partial discharge (pd).
- (6) All pins on each side of the barrier tied together creating a two-terminal device.

6.7 Safety-Related Certifications

VDE	CSA	UL	CQC	TUV
Certified according to DIN EN IEC 60747-17 (VDE 0884-17)	Certified according to IEC 62368-1 and IEC 60601-1	Recognized under UL 1577 Component Recognition Program	Certified according to GB 4943.1	Certified according to EN 61010-1 and EN 62368-1
Reinforced Insulation; Maximum transient isolation voltage, 8000 V _{PK} (ISO7760 in DW-16), 7071 V _{PK} (ISO7761, ISO7762, ISO7763 in DW-16) and 4242 V _{PK} (DBQ-16); Maximum repetitive peak isolation voltage, 2121 V _{PK} (DW-16) and 566 V _{PK} (DBQ-16); Maximum surge isolation voltage, 12800 V _{PK} (DW-16) and 10000 V _{PK} (DBQ-16)	Reinforced insulation per CSA 62368-1 and IEC 62368-1 800 V _{RMS} (DW-16) and 370 V _{RMS} (DBQ-16) maximum working voltage (pollution degree 2, material group I); DW-16: 2 MOPP (Means of Patient Protection) per CSA 60601-1 and IEC 60601-1, 250 V _{RMS} maximum working voltage	DW-16: Single protection, 5000 V _{RMS} ; DBQ-16: Single protection, 3000 V _{RMS}	DW-16: Reinforced Insulation, Altitude ≤ 5000 m, Tropical Climate, 700 V _{RMS} maximum working voltage; DBQ-16: Basic Insulation, Altitude ≤ 5000 m, Tropical Climate, 400 V _{RMS} maximum working voltage	5000 V _{RMS} Reinforced insulation per EN 61010-1 up to working voltage of 600 V _{RMS} (DW-16) and 300 V _{RMS} (DBQ-16) 5000 V _{RMS} Reinforced insulation per EN 62368-1 up to working voltage of 600 V _{RMS} (DW-16) and 370 V _{RMS} (DBQ-16)
Certificate number: 40040142	Master contract number: 220991	File number: E181974	Certificate numbers: CQC15001121716 (DW) CQC18001199097 (DBQ)	Client ID number: 77311

6.8 Safety Limiting Values

Safety limiting⁽¹⁾ intends to minimize potential damage to the isolation barrier upon failure of input or output circuitry.

PARAMETER		TEST CONDITIONS	MIN	TYP	MAX	UNIT
DW-16 PACKAGE						
I _S	Safety input, output, or supply current ⁽¹⁾	R _{θJA} = 60.3°C/W, V _I = 5.5 V, T _J = 150°C, T _A = 25°C, see 6-1			377	mA
		R _{θJA} = 60.3°C/W, V _I = 3.6 V, T _J = 150°C, T _A = 25°C, see 6-1			576	
		R _{θJA} = 60.3°C/W, V _I = 2.75 V, T _J = 150°C, T _A = 25°C, see 6-1			754	
P _S	Safety input, output, or total power ⁽¹⁾	R _{θJA} = 60.3°C/W, T _J = 150°C, T _A = 25°C, see 6-1			2073	mW
T _S	Maximum safety temperature ⁽¹⁾				150	°C
DBQ-16 PACKAGE						
I _S	Safety input, output, or supply current ⁽¹⁾	R _{θJA} = 86.5°C/W, V _I = 5.5 V, T _J = 150°C, T _A = 25°C, see 6-2			263	mA
		R _{θJA} = 86.5°C/W, V _I = 3.6 V, T _J = 150°C, T _A = 25°C, see 6-2			401	
		R _{θJA} = 86.5°C/W, V _I = 2.75 V, T _J = 150°C, T _A = 25°C, see 6-2			525	
P _S	Safety input, output, or total power ⁽¹⁾	R _{θJA} = 86.5°C/W, T _J = 150°C, T _A = 25°C, see 6-2			1445	mW
T _S	Maximum safety temperature ⁽¹⁾				150	°C

(1) The maximum safety temperature, T_S, has the same value as the maximum junction temperature, T_J, specified for the device. The I_S and P_S parameters represent the safety current and safety power respectively. The maximum limits of I_S and P_S should not be exceeded. These limits vary with the ambient temperature, T_A.

The junction-to-air thermal resistance, R_{θJA}, in the table is that of a device installed on a high-K test board for leaded surface-mount packages. Use these equations to calculate the value for each parameter:

T_J = T_A + R_{θJA} × P, where P is the power dissipated in the device.

T_{J(max)} = T_S = T_A + R_{θJA} × P_S, where T_{J(max)} is the maximum allowed junction temperature.

$P_S = I_S \times V_I$, where V_I is the maximum input voltage.

6.9 Electrical Characteristics—5-V Supply

VCC1 = VCC2 = 5 V ± 10% (over recommended operating conditions unless otherwise noted)

PARAMETER		TEST CONDITIONS	MIN	TYP	MAX	UNIT
V _{OH}	High-level output voltage	I _{OH} = -4 mA; See 7-1	V _{CCO} ⁽¹⁾ - 0.4	4.8		V
V _{OL}	Low-level output voltage	I _{OL} = 4 mA; See 7-1		0.2	0.4	V
V _{IT+(IN)}	Rising input switching threshold			0.6 x V _{CCI}	0.7 x V _{CCI}	V
V _{IT-(IN)}	Falling input switching threshold		0.3 x V _{CCI}	0.4 x V _{CCI}		V
V _{I(HYS)}	Input threshold voltage hysteresis		0.1 x V _{CCI}	0.2 x V _{CCI}		V
I _{IH}	High-level input current	V _{IH} = V _{CCI} ⁽¹⁾ at INx			10	μA
I _{IL}	Low-level input current	V _{IL} = 0 V at INx	-10			μA
CMTI	Common mode transient immunity	V _I = V _{CCI} or 0 V, V _{CM} = 1200 V; See 7-3	85	100		kV/μs
C _I	Input Capacitance ⁽²⁾	V _I = V _{CC} / 2 + 0.4 × sin(2πft), f = 1 MHz, V _{CC} = 5 V		2		pF

(1) V_{CCI} = Input-side V_{CC}; V_{CCO} = Output-side V_{CC}

(2) Measured from input pin to same side ground.

6.10 Supply Current Characteristics—5-V Supply

VCC1 = VCC2 = 5 V ± 10% (over recommended operating conditions unless otherwise noted).

PARAMETER	TEST CONDITIONS	SUPPLY CURRENT	MIN	TYP	MAX	UNIT	
ISO7760-Q1							
Supply current - DC signal	V _I = V _{CCI} (ISO7760-Q1); V _I = 0 V (ISO7760-Q1 with F suffix)	I _{CC1}		1.6	2.9	mA	
		I _{CC2}		3	5.3		
	V _I = 0 V (ISO7760-Q1); V _I = V _{CCI} (ISO7760-Q1 with F suffix)	I _{CC1}		8	11.3		
		I _{CC2}		3.3	5.7		
Supply current - AC signal	All channels switching with square wave clock input; C _L = 15 pF	1 Mbps	I _{CC1}		5		6.5
			I _{CC2}		3.5		5.9
		10 Mbps	I _{CC1}		5.2		6.7
			I _{CC2}		6.4		9.7
		100 Mbps	I _{CC1}		7	9.2	
			I _{CC2}		35	47	
ISO7761-Q1							
Supply current - DC signal	V _I = V _{CCI} ⁽¹⁾ (ISO7761-Q1); V _I = 0 V (ISO7761-Q1 with F suffix)	I _{CC1}		1.9	3.5	mA	
		I _{CC2}		2.9	5.4		
	V _I = 0 V (ISO7761-Q1); V _I = V _{CCI} (ISO7761-Q1 with F suffix)	I _{CC1}		7.3	10.6		
		I _{CC2}		4.2	6.9		
Supply current - AC signal	All channels switching with square wave clock input; C _L = 15 pF	1 Mbps	I _{CC1}		4.7		6.6
			I _{CC2}		3.8		6.5
		10 Mbps	I _{CC1}		5.3		8
			I _{CC2}		6.3		9.6
		100 Mbps	I _{CC1}		11.5	15.6	
			I _{CC2}		30.5	40.3	
ISO7762-Q1							

$V_{CC1} = V_{CC2} = 5\text{ V} \pm 10\%$ (over recommended operating conditions unless otherwise noted).

PARAMETER	TEST CONDITIONS	SUPPLY CURRENT	MIN	TYP	MAX	UNIT	
Supply current - DC signal	$V_I = V_{CCI}$ (ISO7762-Q1); $V_I = 0\text{ V}$ (ISO7762-Q1 with F suffix)	I_{CC1}		2.1	4.1	mA	
		I_{CC2}		2.6	4.9		
	$V_I = 0\text{ V}$ (ISO7762-Q1); $V_I = V_{CCI}$ (ISO7762-Q1 with F suffix)	I_{CC1}		6.5	9.3		
		I_{CC2}		5	7.6		
Supply current - AC signal	All channels switching with square wave clock input; $C_L = 15\text{ pF}$	1 Mbps	I_{CC1}		4.5	6.7	
			I_{CC2}		4	6.5	
		10 Mbps	I_{CC1}		5.6	8	
			I_{CC2}		6	8.9	
		100 Mbps	I_{CC1}		16.5	21.3	
			I_{CC2}		25.7	34	
ISO7763-Q1							
Supply current - DC signal	$V_I = V_{CCI}$ (ISO7763-Q1); $V_I = 0\text{ V}$ (ISO7763-Q1 with F suffix)	I_{CC1}, I_{CC2}		2.4	4.7	mA	
		I_{CC1}, I_{CC2}		5.7	8.6		
Supply current - AC signal	All channels switching with square wave clock input; $C_L = 15\text{ pF}$	1 Mbps	I_{CC1}, I_{CC2}		4.2		6.8
		10 Mbps	I_{CC1}, I_{CC2}		5.8		8.7
		100 Mbps	I_{CC1}, I_{CC2}		21	28.4	

(1) $V_{CCI} = \text{Input-side } V_{CC}$

6.11 Electrical Characteristics—3.3-V Supply

$V_{CC1} = V_{CC2} = 3.3\text{ V} \pm 10\%$ (over recommended operating conditions unless otherwise noted).

PARAMETER		TEST CONDITIONS	MIN	TYP	MAX	UNIT
V_{OH}	High-level output voltage	$I_{OH} = -2\text{mA}$; See 7-1	$V_{CCO}^{(1)} - 0.3$	3.2		V
V_{OL}	Low-level output voltage	$I_{OL} = 2\text{mA}$; See 7-1		0.1	0.3	V
$V_{IT+(IN)}$	Rising input switching threshold			$0.6 \times V_{CCI}$	$0.7 \times V_{CCI}^{(1)}$	V
$V_{IT-(IN)}$	Falling input switching threshold		$0.3 \times V_{CCI}$	$0.4 \times V_{CCI}$		V
$V_{I(HYS)}$	Input threshold voltage hysteresis		$0.1 \times V_{CCI}$	$0.2 \times V_{CCI}$		V
I_{IH}	High-level input current	$V_{IH} = V_{CCI}^{(1)}$ at INx			10	μA
I_{IL}	Low-level input current	$V_{IL} = 0\text{ V}$ at INx	-10			μA
CMTI	Common mode transient immunity	$V_I = V_{CC}$ or 0 V , $V_{CM} = 1200\text{ V}$; See 7-3	85	100		kV/us

(1) V_{CCI} = Input-side V_{CC} ; V_{CCO} = Output-side V_{CC}

6.12 Supply Current Characteristics—3.3-V Supply

$V_{CC1} = V_{CC2} = 3.3\text{ V} \pm 10\%$ (over recommended operating conditions unless otherwise noted).

PARAMETER	TEST CONDITIONS	SUPPLY CURRENT	MIN	TYP	MAX	UNIT	
ISO7760-Q1							
Supply current - DC signal	$V_I = V_{CC1}$ (ISO7760-Q1); $V_I = 0\text{ V}$ (ISO7760-Q1 with F suffix)	I_{CC1}		1.6	2.9	mA	
		I_{CC2}		3	5.3		
	$V_I = 0\text{ V}$ (ISO7760-Q1); $V_I = V_{CC1}$ (ISO7760-Q1 with F suffix)	I_{CC1}		8	11.4		
		I_{CC2}		3.3	5.7		
Supply current - AC signal	All channels switching with square wave clock input; $C_L = 15\text{ pF}$	1 Mbps	I_{CC1}		4.9		6.4
			I_{CC2}		3.4		5.7
		10 Mbps	I_{CC1}		5		6.6
			I_{CC2}		5.5		8.5
		100 Mbps	I_{CC1}		6.3	8.1	
			I_{CC2}		26	35	
ISO7761-Q1							
Supply current - DC signal	$V_I = V_{CCI}^{(1)}$ (ISO7761-Q1); $V_I = 0\text{ V}$ (ISO7761-Q1 with F suffix)	I_{CC1}		1.8	3.5	mA	
		I_{CC2}		2.9	5.3		
	$V_I = 0\text{ V}$ (ISO7761-Q1); $V_I = V_{CCI}$ (ISO7761-Q1 with F suffix)	I_{CC1}		7.2	10.3		
		I_{CC2}		4.2	6.9		
Supply current - AC signal	All channels switching with square wave clock input; $C_L = 15\text{ pF}$	1 Mbps	I_{CC1}		4.6		6.5
			I_{CC2}		3.7		6.3
		10 Mbps	I_{CC1}		5.1		7.5
			I_{CC2}		5.5		8.6
		100 Mbps	I_{CC1}		9.4	12.7	
			I_{CC2}		22.8	30.5	
ISO7762-Q1							

$V_{CC1} = V_{CC2} = 3.3\text{ V} \pm 10\%$ (over recommended operating conditions unless otherwise noted).

PARAMETER	TEST CONDITIONS	SUPPLY CURRENT	MIN	TYP	MAX	UNIT
Supply current - DC signal	$V_I = V_{CCI}$ (ISO7762-Q1); $V_I = 0\text{ V}$ (ISO7762-Q1 with F suffix)	I_{CC1}		2.1	4	mA
		I_{CC2}		2.5	4.8	
	$V_I = 0\text{ V}$ (ISO7762-Q1); $V_I = V_{CCI}$ (ISO7762-Q1 with F suffix)	I_{CC1}		6.5	9.4	
		I_{CC2}		5	7.5	
Supply current - AC signal	All channels switching with square wave clock input; $C_L = 15\text{ pF}$	1 Mbps	I_{CC1}	4.4	6.6	mA
			I_{CC2}	3.9	6.3	
		10 Mbps	I_{CC1}	5.2	7.5	
			I_{CC2}	5.4	8.1	
		100 Mbps	I_{CC1}	12.9	16.9	
			I_{CC2}	19.5	26	
ISO7763-Q1						
Supply current - DC signal	$V_I = V_{CCI}$ (ISO7763-Q1); $V_I = 0\text{ V}$ (ISO7763-Q1 with F suffix)	I_{CC1}, I_{CC2}		2.4	4.6	mA
		I_{CC1}, I_{CC2}		5.7	8.4	
Supply current - AC signal	All channels switching with square wave clock input; $C_L = 15\text{ pF}$	1 Mbps	I_{CC1}, I_{CC2}	4.2	6.6	mA
		10 Mbps	I_{CC1}, I_{CC2}	5.2	8.1	
		100 Mbps	I_{CC1}, I_{CC2}	16	21.9	

(1) $V_{CCI} = \text{Input-side } V_{CC}$

6.13 Electrical Characteristics—2.5-V Supply

$V_{CC1} = V_{CC2} = 2.5\text{ V} \pm 10\%$ (over recommended operating conditions unless otherwise noted).

PARAMETER		TEST CONDITIONS	MIN	TYP	MAX	UNIT
V_{OH}	High-level output voltage	$I_{OH} = -1\text{ mA}$; See 7-1	$V_{CCO}^{(1)} - 0.2$	2.45		V
V_{OL}	Low-level output voltage	$I_{OL} = 1\text{ mA}$; See 7-1		0.05	0.2	V
$V_{IT+(IN)}$	Rising input switching threshold			$0.6 \times V_{CCI}$	$0.7 \times V_{CCI}^{(1)}$	V
$V_{IT-(IN)}$	Falling input switching threshold		$0.3 \times V_{CCI}$	$0.4 \times V_{CCI}$		V
$V_{I(HYS)}$	Input threshold voltage hysteresis		$0.1 \times V_{CCI}$	$0.2 \times V_{CCI}$		V
I_{IH}	High-level input current	$V_{IH} = V_{CCI}^{(1)}$ at INx			10	μA
I_{IL}	Low-level input current	$V_{IL} = 0\text{ V}$ at INx	-10			μA
CMTI	Common mode transient immunity	$V_I = V_{CC}$ or 0 V , $V_{CM} = 1200\text{ V}$; See 7-3	85	100		kV/us

(1) V_{CCI} = Input-side V_{CC} ; V_{CCO} = Output-side V_{CC}

6.14 Supply Current Characteristics—2.5-V Supply

$V_{CC1} = V_{CC2} = 2.5\text{ V} \pm 10\%$ (over recommended operating conditions unless otherwise noted).

PARAMETER	TEST CONDITIONS	SUPPLY CURRENT	MIN	TYP	MAX	UNIT	
ISO7760-Q1							
Supply current - DC signal	$V_I = V_{CC1}$ (ISO7760-Q1); $V_I = 0\text{ V}$ (ISO7760-Q1 with F suffix)	I_{CC1}		1.6	2.9	mA	
		I_{CC2}		3	5.2		
	$V_I = 0\text{ V}$ (ISO7760-Q1); $V_I = V_{CC1}$ (ISO7760-Q1 with F suffix)	I_{CC1}		8	11.6		
		I_{CC2}		3.3	5.7		
Supply current - AC signal	All channels switching with square wave clock input; $C_L = 15\text{ pF}$	1 Mbps	I_{CC1}		4.9		6.4
			I_{CC2}		3.4		5.7
		10 Mbps	I_{CC1}		5		6.5
			I_{CC2}		4.9		7.7
		100 Mbps	I_{CC1}		6	7.7	
			I_{CC2}		20.3	27.9	
ISO7761-Q1							
Supply current - DC signal	$V_I = V_{CCI}^{(1)}$ (ISO7761-Q1); $V_I = 0\text{ V}$ (ISO7761-Q1 with F suffix)	I_{CC1}		1.8	3.4	mA	
		I_{CC2}		2.9	5.3		
	$V_I = 0\text{ V}$ (ISO7761-Q1); $V_I = V_{CCI}$ (ISO7761-Q1 with F suffix)	I_{CC1}		7.2	10.3		
		I_{CC2}		4.2	6.8		
Supply current - AC signal	All channels switching with square wave clock input; $C_L = 15\text{ pF}$	1 Mbps	I_{CC1}		4.6		6.5
			I_{CC2}		3.7		6.3
		10 Mbps	I_{CC1}		4.9		7.2
			I_{CC2}		5		7.9
		100 Mbps	I_{CC1}		8.3	11.2	
			I_{CC2}		18.1	24.6	
ISO7762-Q1							

$V_{CC1} = V_{CC2} = 2.5\text{ V} \pm 10\%$ (over recommended operating conditions unless otherwise noted).

PARAMETER	TEST CONDITIONS	SUPPLY CURRENT	MIN	TYP	MAX	UNIT	
Supply current - DC signal	$V_I = V_{CCI}$ (ISO7762-Q1); $V_I = 0\text{ V}$ (ISO7762-Q1 with F suffix)	I_{CC1}		2.1	4	mA	
		I_{CC2}		2.6	4.8		
	$V_I = 0\text{ V}$ (ISO7762-Q1); $V_I = V_{CCI}$ (ISO7762-Q1 with F suffix)	I_{CC1}		6.5	9.6		
		I_{CC2}		4.9	7.4		
Supply current - AC signal	All channels switching with square wave clock input; $C_L = 15\text{ pF}$	1 Mbps	I_{CC1}		4.4		6.5
			I_{CC2}		3.9		6.3
		10 Mbps	I_{CC1}		5		7.2
			I_{CC2}		5		7.6
		100 Mbps	I_{CC1}		10.9	14.4	
			I_{CC2}		15.6	21.3	
ISO7763-Q1							
Supply current - DC signal	$V_I = V_{CCI}$ (ISO7763-Q1); $V_I = 0\text{ V}$ (ISO7763-Q1 with F suffix)	I_{CC1}, I_{CC2}		2.3	4.6	mA	
		I_{CC1}, I_{CC2}		5.7	8.4		
Supply current - AC signal	All channels switching with square wave clock input; $C_L = 15\text{ pF}$	1 Mbps	I_{CC1}, I_{CC2}		4.1		6.6
		10 Mbps	I_{CC1}, I_{CC2}		4.9		7.6
		100 Mbps	I_{CC1}, I_{CC2}		13		18.1

(1) $V_{CCI} = \text{Input-side } V_{CC}$

6.15 Switching Characteristics—5-V Supply

$V_{CC1} = V_{CC2} = 5\text{ V} \pm 10\%$ (over recommended operating conditions unless otherwise noted)

PARAMETER		TEST CONDITIONS	MIN	TYP	MAX	UNIT
ISO776x-Q1						
t_{PLH}, t_{PHL}	Propagation delay time	See 7-1	6	11	17	ns
PWD	Pulse width distortion ⁽¹⁾ $ t_{PHL} - t_{PLH} $		0.4	5.9	ns	
$t_{sk(o)}$	Channel-to-channel output skew time ⁽²⁾	Same-direction channels			4	ns
$t_{sk(pp)}$	Part-to-part skew time ⁽³⁾				4.5	ns
t_r	Output signal rise time	See 7-1		1.1	3.9	ns
t_f	Output signal fall time		1.4	3.9	ns	
t_{DO}	Default output delay time from input power loss	Measured from the time V_{CC} goes below 1.7V. See 7-2		0.2	0.3	μs
t_{ie}	Time interval error	$2^{16} - 1$ PRBS data at 100 Mbps		1.3		ns

- (1) Also known as pulse skew.
- (2) $t_{sk(o)}$ is the skew between outputs of a single device with all driving inputs connected together and the outputs switching in the same direction while driving identical loads.
- (3) $t_{sk(pp)}$ is the magnitude of the difference in propagation delay times between any terminals of different devices switching in the same direction while operating at identical supply voltages, temperature, input signals and loads.

6.16 Switching Characteristics—3.3-V Supply

$V_{CC1} = V_{CC2} = 3.3\text{ V} \pm 10\%$ (over recommended operating conditions unless otherwise noted)

PARAMETER		TEST CONDITIONS	MIN	TYP	MAX	UNIT
ISO776x-Q1						
t_{PLH}, t_{PHL}	Propagation delay time	See 7-1	6	12	18.5	ns
PWD	Pulse width distortion ⁽¹⁾ $ t_{PHL} - t_{PLH} $					
$t_{sk(o)}$	Channel-to-channel output skew time ⁽²⁾	Same-direction channels			4.4	ns
$t_{sk(pp)}$	Part-to-part skew time ⁽³⁾				5	ns
t_r	Output signal rise time	See 7-1		1	3	ns
t_f	Output signal fall time					
t_{DO}	Default output delay time from input power loss	Measured from the time V_{CC} goes below 1.7V. See 7-2		0.2	0.3	μs
t_{ie}	Time interval error	$2^{16} - 1$ PRBS data at 100 Mbps		1.3		ns

- (1) Also known as pulse skew.
- (2) $t_{sk(o)}$ is the skew between outputs of a single device with all driving inputs connected together and the outputs switching in the same direction while driving identical loads.
- (3) $t_{sk(pp)}$ is the magnitude of the difference in propagation delay times between any terminals of different devices switching in the same direction while operating at identical supply voltages, temperature, input signals and loads.

6.17 Switching Characteristics—2.5-V Supply

$V_{CC1} = V_{CC2} = 2.5\text{ V} \pm 10\%$ (over recommended operating conditions unless otherwise noted)

PARAMETER		TEST CONDITIONS	MIN	TYP	MAX	UNIT
ISO776x-Q1						
t_{PLH}, t_{PHL}	Propagation delay time	See 7-1	7.5	13	21	ns
PWD	Pulse width distortion ⁽¹⁾ $ t_{PHL} - t_{PLH} $		0.6	5.9	ns	
$t_{sk(o)}$	Channel-to-channel output skew time ⁽²⁾	Same-direction channels			4.4	ns
$t_{sk(pp)}$	Part-to-part skew time ⁽³⁾				5.3	ns
t_r	Output signal rise time	See 7-1		1	3.5	ns
t_f	Output signal fall time			1	3.5	ns
t_{DO}	Default output delay time from input power loss	Measured from the time V_{CC} goes below 1.7V. See 7-2		0.1	0.3	μs
t_{ie}	Time interval error	$2^{16} - 1$ PRBS data at 100 Mbps		1.3		ns

- (1) Also known as pulse skew.
- (2) $t_{sk(o)}$ is the skew between outputs of a single device with all driving inputs connected together and the outputs switching in the same direction while driving identical loads.
- (3) $t_{sk(pp)}$ is the magnitude of the difference in propagation delay times between any terminals of different devices switching in the same direction while operating at identical supply voltages, temperature, input signals and loads.

6.18 Insulation Characteristics Curves

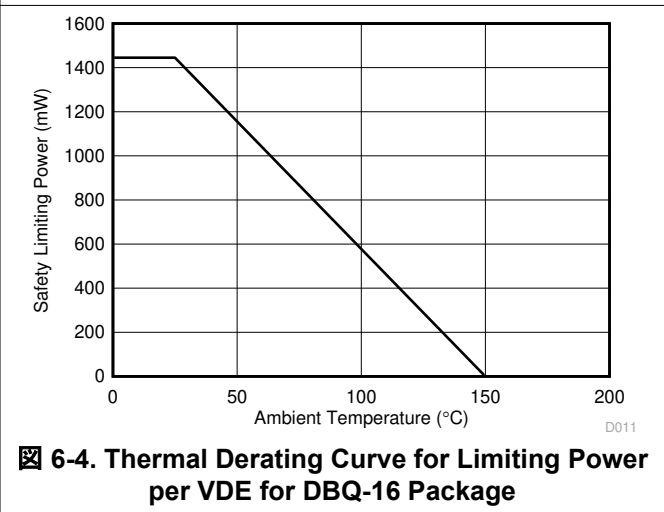
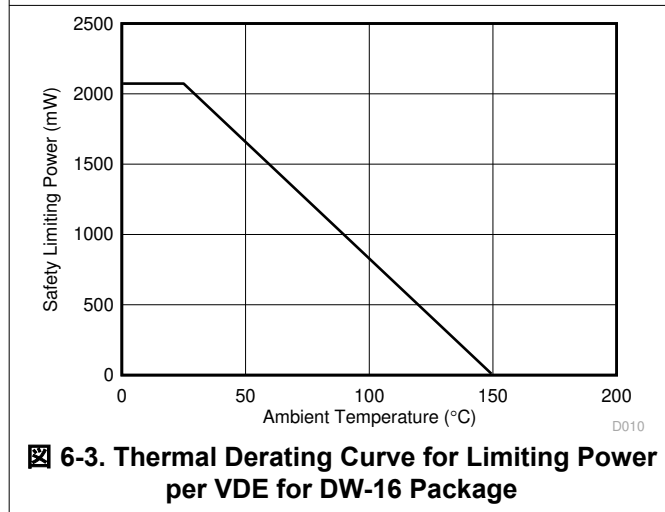
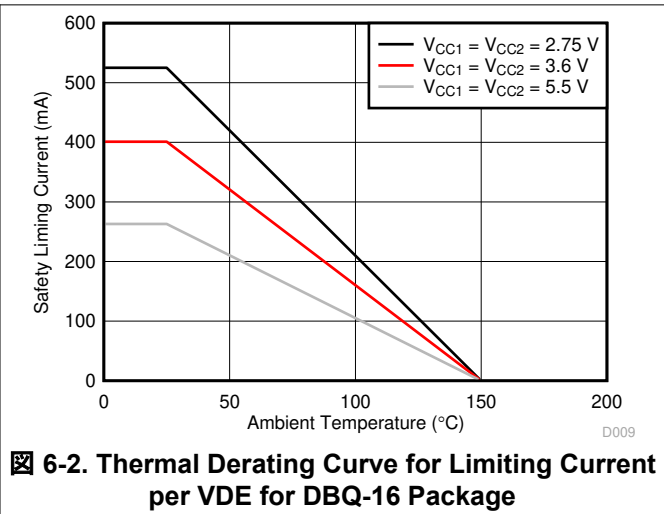
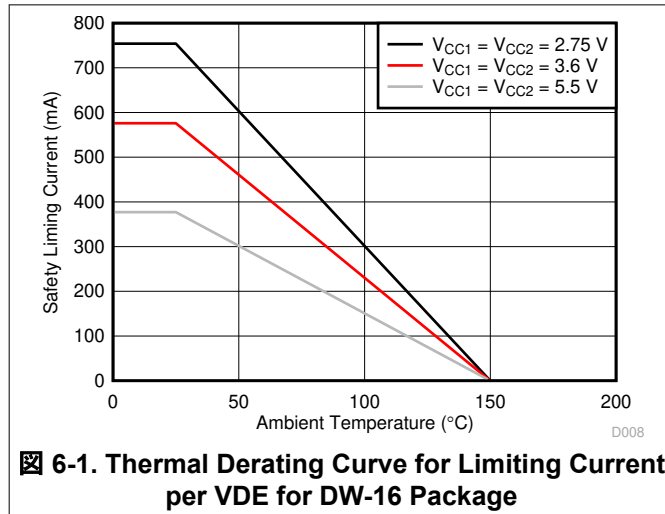

6.19 Typical Characteristics

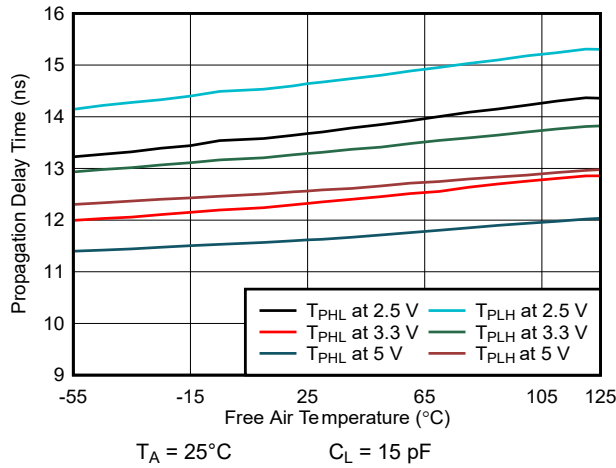

6-5. ISO7760-Q1 Supply Current vs Data Rate (With 15-pF Load)

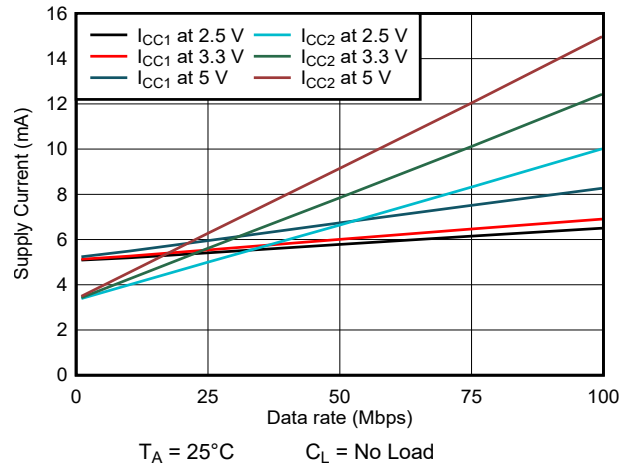

6-6. ISO7760-Q1 Supply Current vs Data Rate (With No Load)

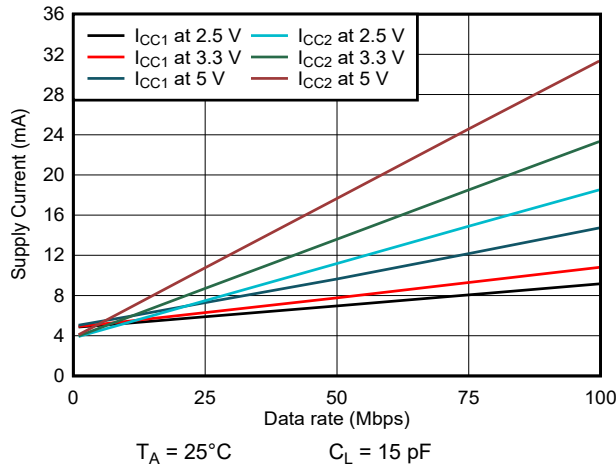

6-7. ISO7761-Q1 Supply Current vs Data Rate (With 15-pF Load)

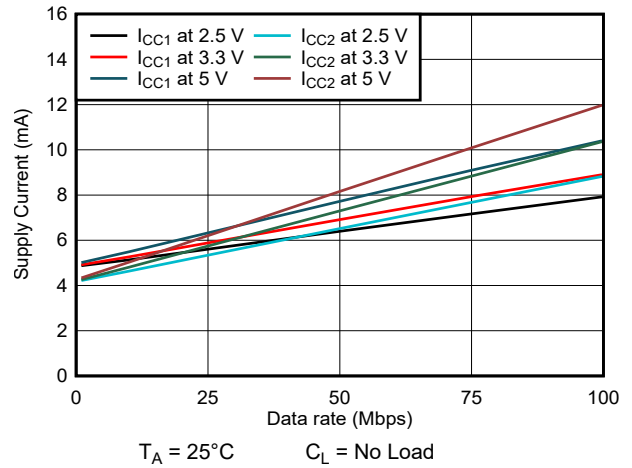

6-8. ISO7761-Q1 Supply Current vs Data Rate (With No Load)

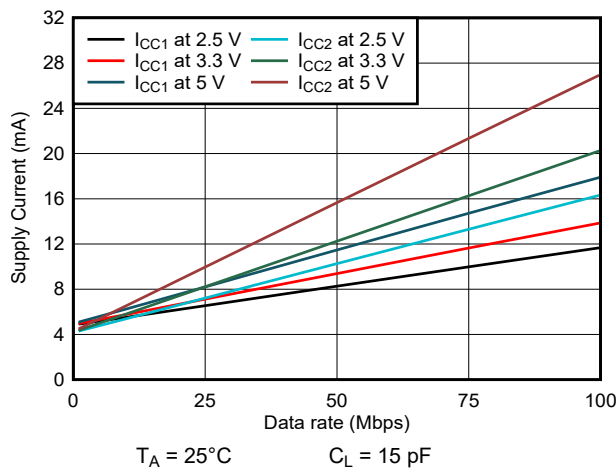

6-9. ISO7762-Q1 Supply Current vs Data Rate (With 15-pF Load)

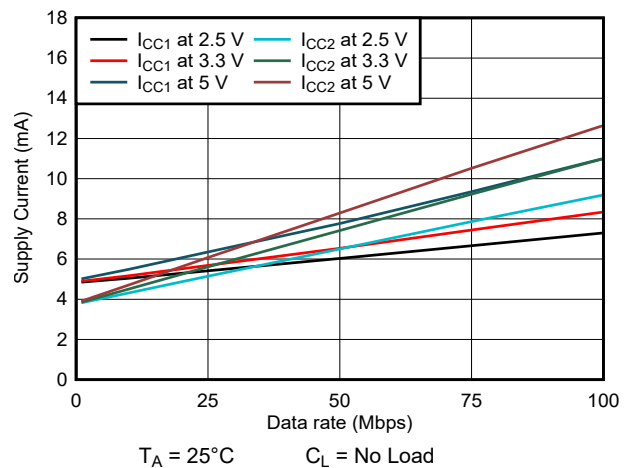

6-10. ISO7762-Q1 Supply Current vs Data Rate (With No Load)

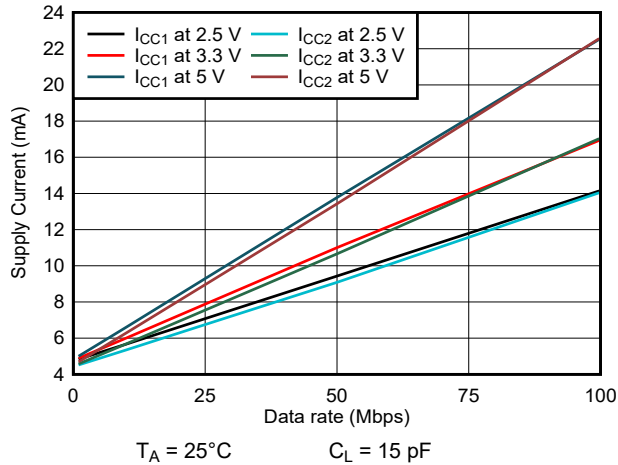

6-11. ISO7763-Q1 Supply Current vs Data Rate (With 15-pF Load)

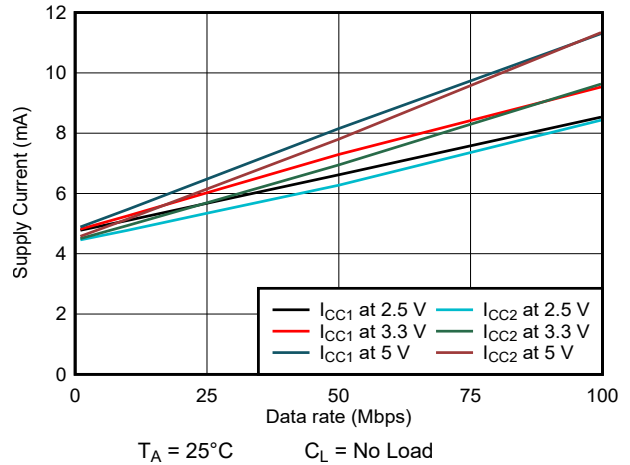

6-12. ISO7763-Q1 Supply Current vs Data Rate (With No Load)

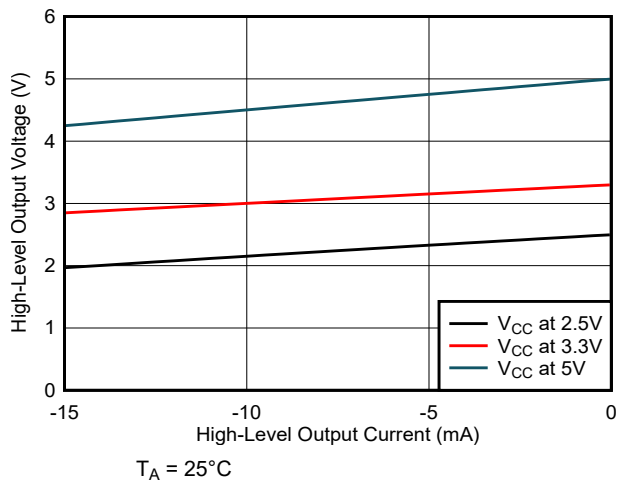

6-13. High-Level Output Voltage vs High-Level Output Current

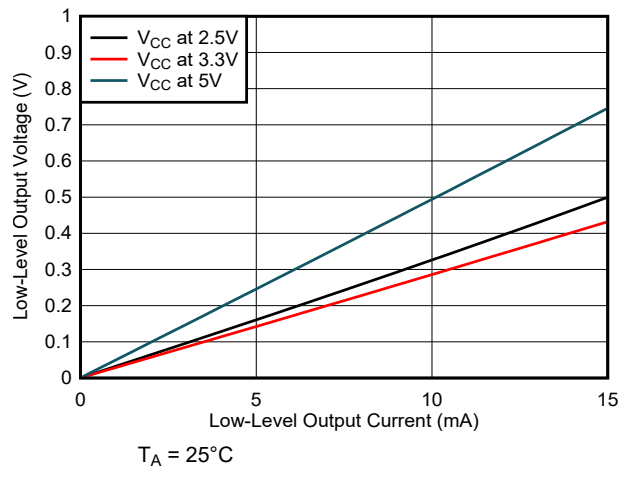

6-14. Low-Level Output Voltage vs Low-Level Output Current

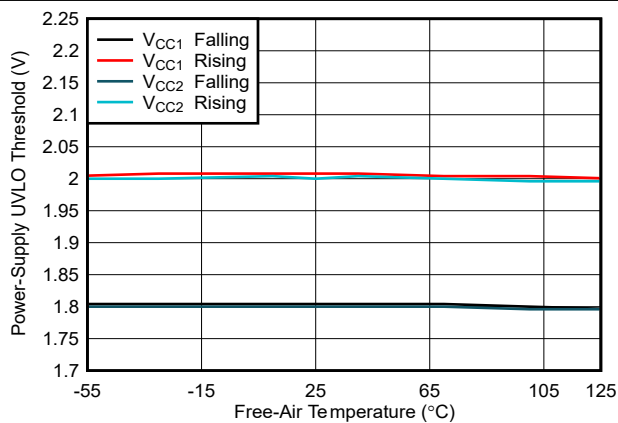

6-15. Power Supply Undervoltage Threshold vs Free-Air Temperature

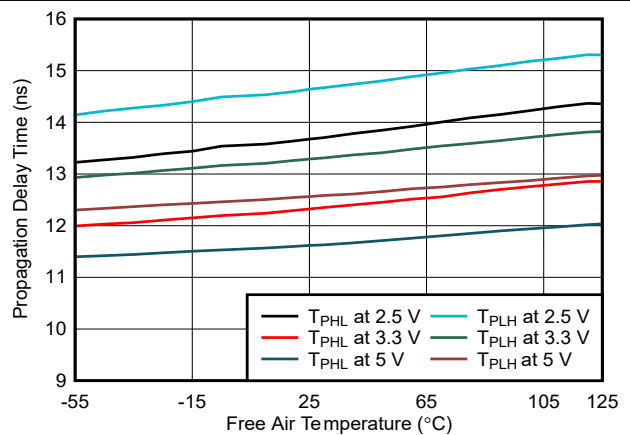

6-16. Propagation Delay Time vs Free-Air Temperature

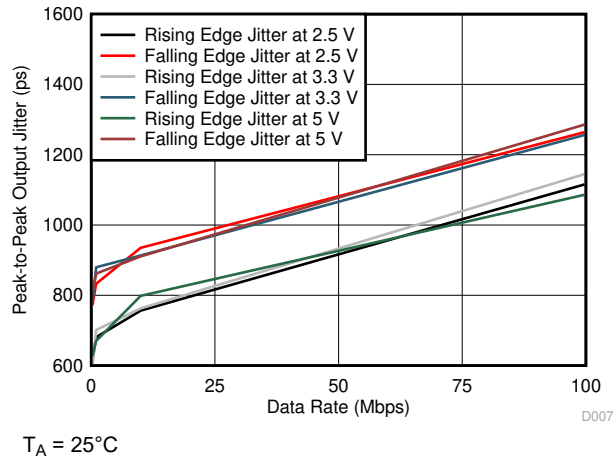

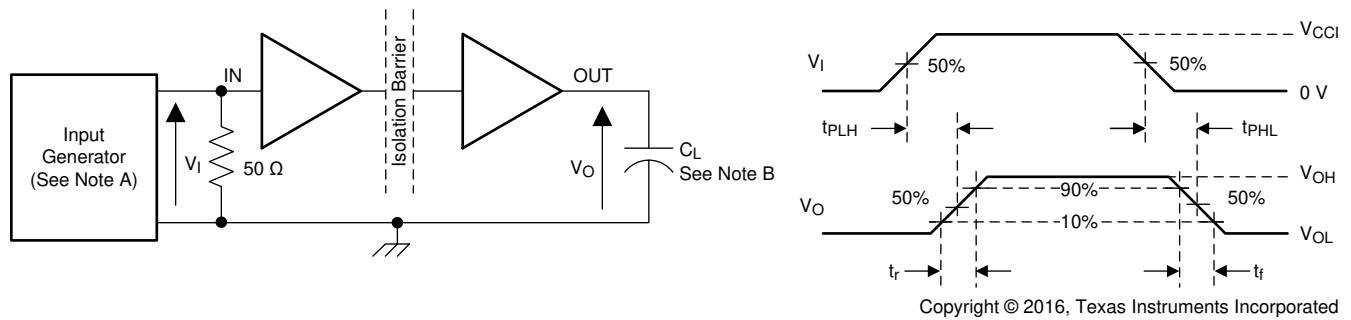

6-17. Peak-to-Peak Output Jitter vs Data Rate

Parameter Measurement Information

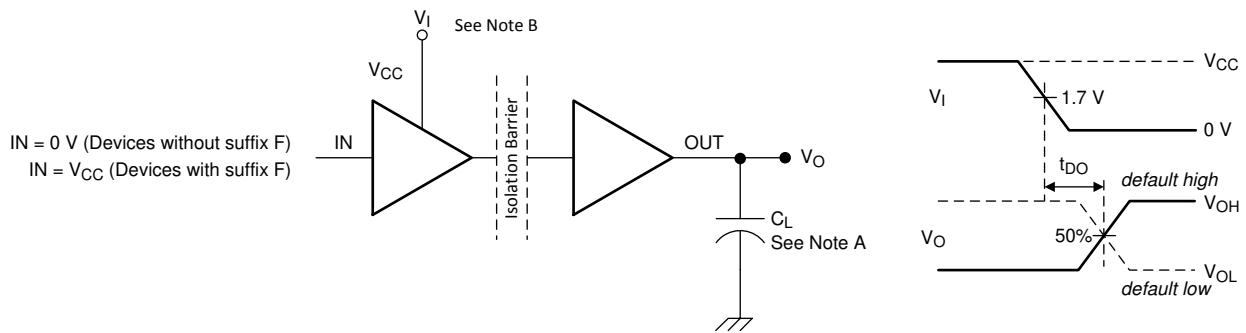

- A. The input pulse is supplied by a generator having the following characteristics: PRR ≤ 50 kHz, 50% duty cycle, $t_r \leq 3$ ns, $t_f \leq 3$ ns, $Z_O = 50 \Omega$. At the input, a 50- Ω resistor is required to terminate Input Generator signal. It is not needed in actual application.
- B. $C_L = 15$ pF and includes instrumentation and fixture capacitance within $\pm 20\%$.

7-1. Switching Characteristics Test Circuit and Voltage Waveforms



- A. $C_L = 15$ pF and includes instrumentation and fixture capacitance within $\pm 20\%$.
- B. Power-supply ramp rate = 10 mV/ns

7-2. Default Output Delay Time Test Circuit and Voltage Waveforms

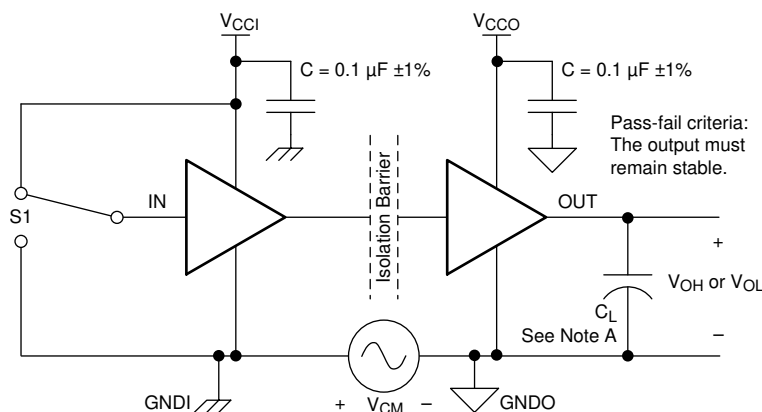

- A. $C_L = 15$ pF and includes instrumentation and fixture capacitance within $\pm 20\%$.

7-3. Common-Mode Transient Immunity Test Circuit

7 Detailed Description

7.1 Overview

The ISO776x-Q1 family of devices uses an ON-OFF keying (OOK) modulation scheme to transmit the digital data across a silicon-dioxide based isolation barrier. The transmitter sends a high-frequency carrier across the barrier to represent one digital state and sends no signal to represent the other digital state. The receiver demodulates the signal after advanced signal conditioning and produces the output through a buffer stage. The ISO776x-Q1 family of devices also incorporates advanced circuit techniques to maximize the CMTI performance and minimize the radiated emissions because of the high-frequency carrier and IO buffer switching. The conceptual block diagram of a digital capacitive isolator, [Figure 7-1](#), shows a functional block diagram of a typical channel. [Figure 7-2](#) shows a conceptual detail of how the ON-OFF keying scheme works.

7.2 Functional Block Diagram

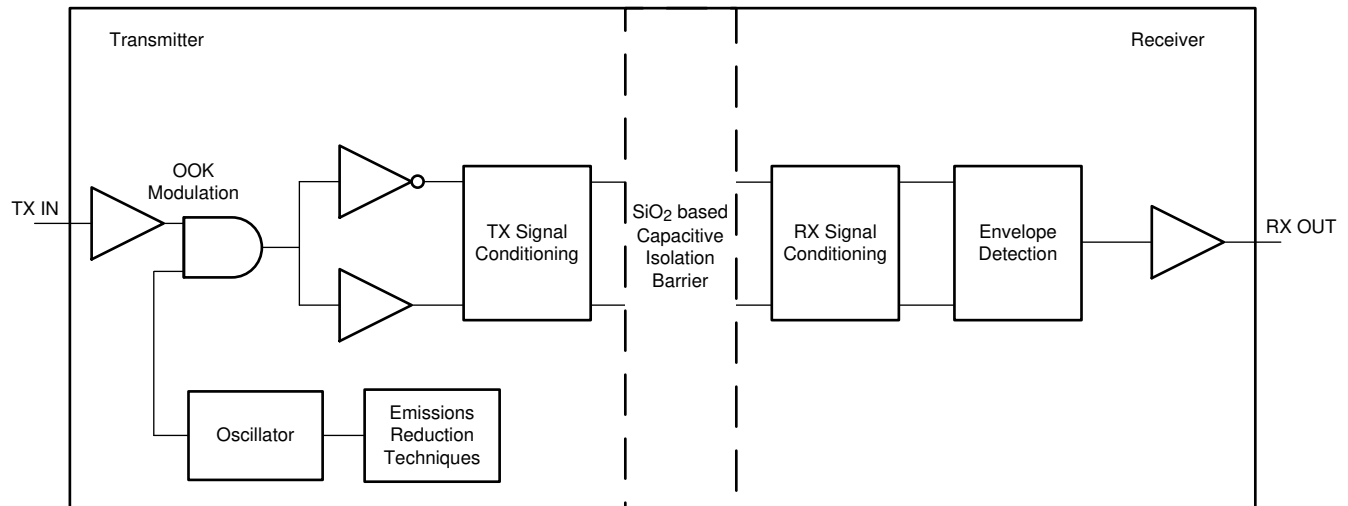

Copyright © 2016, Texas Instruments Incorporated

Figure 7-1. Conceptual Block Diagram of a Digital Capacitive Isolator

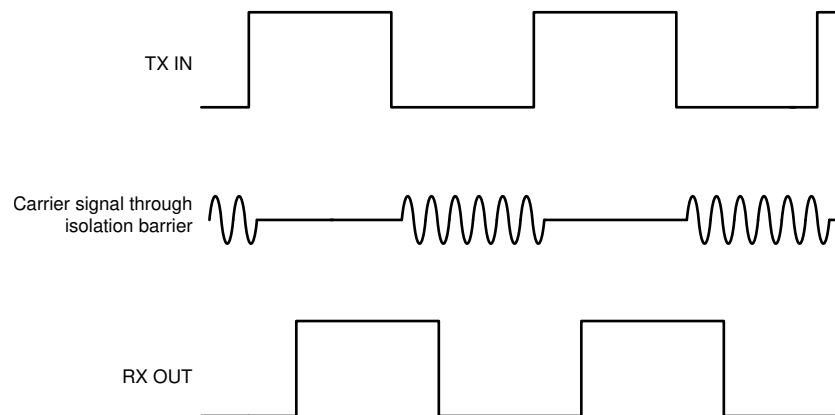

Figure 7-2. ON-OFF Keying (OOK) Based Modulation Scheme

7.3 Feature Description

表 7-1 lists the device features.

表 7-1. Device Features

PART NUMBER	CHANNEL DIRECTION	MAXIMUM DATA RATE	DEFAULT OUTPUT	PACKAGE	RATED ISOLATION ⁽¹⁾
ISO7760-Q1	6 Forward, 0 Reverse	100 Mbps	High	DW-16	5000 V _{RMS} / 8000 V _{PK}
				DBQ-16	3000 V _{RMS} / 4242 V _{PK}
ISO7760-Q1 with F suffix	6 Forward, 0 Reverse	100 Mbps	Low	DW-16	5000 V _{RMS} / 8000 V _{PK}
				DBQ-16	3000 V _{RMS} / 4242 V _{PK}
ISO7761-Q1	5 Forward, 1 Reverse	100 Mbps	High	DW-16	5000 V _{RMS} / 8000V _{PK}
				DBQ-16	3000 V _{RMS} / 4242 V _{PK}
ISO7761-Q1 with F suffix	5 Forward, 1 Reverse	100 Mbps	Low	DW-16	5000 V _{RMS} / 8000 V _{PK}
				DBQ-16	3000 V _{RMS} / 4242 V _{PK}
ISO7762-Q1	4 Forward, 2 Reverse	100 Mbps	High	DW-16	5000 V _{RMS} / 8000V _{PK}
				DBQ-16	3000 V _{RMS} / 4242 V _{PK}
ISO7762-Q1 with F suffix	4 Forward, 2 Reverse	100 Mbps	Low	DW-16	5000 V _{RMS} / 8000V _{PK}
				DBQ-16	3000 V _{RMS} / 4242 V _{PK}
ISO7763-Q1	3 Forward, 3 Reverse	100 Mbps	High	DW-16	5000 V _{RMS} / 8000V _{PK}
				DBQ-16	3000 V _{RMS} / 4242 V _{PK}
ISO7763-Q1 with F suffix	3 Forward, 3 Reverse	100 Mbps	Low	DW-16	5000 V _{RMS} / 8000 V _{PK}
				DBQ-16	3000 V _{RMS} / 4242 V _{PK}

(1) See [セクション 6.7](#) for detailed isolation ratings.

7.3.1 Electromagnetic Compatibility (EMC) Considerations

Many applications in harsh industrial environment are sensitive to disturbances such as electrostatic discharge (ESD), electrical fast transient (EFT), surge and electromagnetic emissions. These electromagnetic disturbances are regulated by international standards such as IEC 61000-4-x and CISPR 22. Although system-level performance and reliability depends, to a large extent, on the application board design and layout, the ISO776x-Q1 family of devices incorporates many chip-level design improvements for overall system robustness. Some of these improvements include:

- Robust ESD protection for input and output signal pins and inter-chip bond pads.
- Low-resistance connectivity of ESD cells to supply and ground pins.
- Enhanced performance of high voltage isolation capacitor for better tolerance of ESD, EFT and surge events.
- Bigger on-chip decoupling capacitors to bypass undesirable high energy signals through a low impedance path.
- PMOS and NMOS devices isolated from each other by using guard rings to avoid triggering of parasitic SCRs.
- Reduced common mode currents across the isolation barrier by ensuring purely differential internal operation.

7.4 Device Functional Modes

表 7-2 lists the functional modes for the ISO776x-Q1.

表 7-2. Function Table

V _{CCI} ⁽¹⁾	V _{CCO}	INPUT (IN _x) ⁽³⁾	OUTPUT (OUT _x)	COMMENTS
PU	PU	H	H	Normal Operation: A channel output assumes the logic state of the input.
		L	L	
		Open	Default	Default mode: When IN _x is open, the corresponding channel output goes to its default logic state. Default is <i>High</i> for ISO776x-Q1 and <i>Low</i> for ISO776x-Q1 with F suffix.
PD	PU	X	Default	Default mode: When V _{CCI} is unpowered, a channel output assumes the logic state based on the selected default option. Default is <i>High</i> for ISO776x-Q1 and <i>Low</i> for ISO776x-Q1 with F suffix. When V _{CCI} transitions from unpowered to powered-up, a channel output assumes the logic state of its input. When V _{CCI} transitions from powered-up to unpowered, channel output assumes the selected default state.
X	PD	X	Undetermined	When V _{CCO} is unpowered, a channel output is undetermined ⁽²⁾ . When V _{CCO} transitions from unpowered to powered-up, a channel output assumes the logic state of the input

- (1) V_{CCI} = Input-side V_{CC}; V_{CCO} = Output-side V_{CC}; PU = Powered up (V_{CC} ≥ 2.25 V); PD = Powered down (V_{CC} ≤ 1.7 V); X = Irrelevant; H = High level; L = Low level
 (2) The outputs are in undetermined state when 1.7 V < V_{CCI}, V_{CCO} < 2.25 V.
 (3) A strongly driven input signal can weakly power the floating V_{CC} via an internal protection diode and cause undetermined output.

7.4.1 Device I/O Schematics

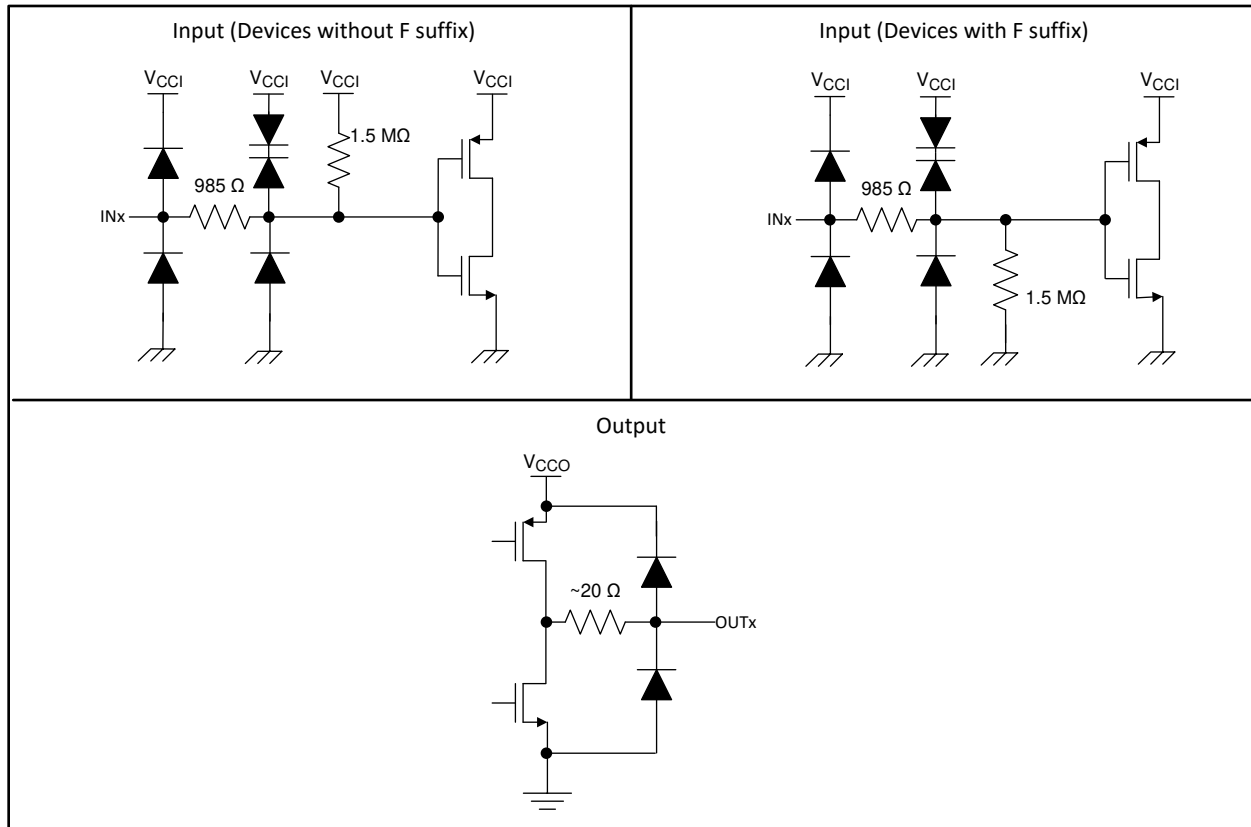

Copyright © 2016, Texas Instruments Incorporated

图 7-3. Device I/O Schematics

8 Application and Implementation

注

Information in the following applications sections is not part of the TI component specification, and TI does not warrant its accuracy or completeness. TI's customers are responsible for determining suitability of components for their purposes. Customers should validate and test their design implementation to confirm system functionality.

8.1 Application Information

The ISO776x-Q1 family of devices is a high-performance, six-channel digital isolators. The ISO776x-Q1 family of devices uses single-ended CMOS-logic switching technology. The voltage range is from 2.25 V to 5.5 V for both supplies, V_{CC1} and V_{CC2} . When designing with digital isolators, keep in mind that because of the single-ended design structure, digital isolators do not conform to any specific interface standard and are only intended for isolating single-ended CMOS or TTL digital signal lines. The isolator is typically placed between the data controller (that is, μ C or UART), and a data converter or a line transceiver, regardless of the interface type or standard.

8.2 Typical Application

Figure 8-1 shows the isolated serial-peripheral interface (SPI) and controller-area network (CAN) interface implementation.

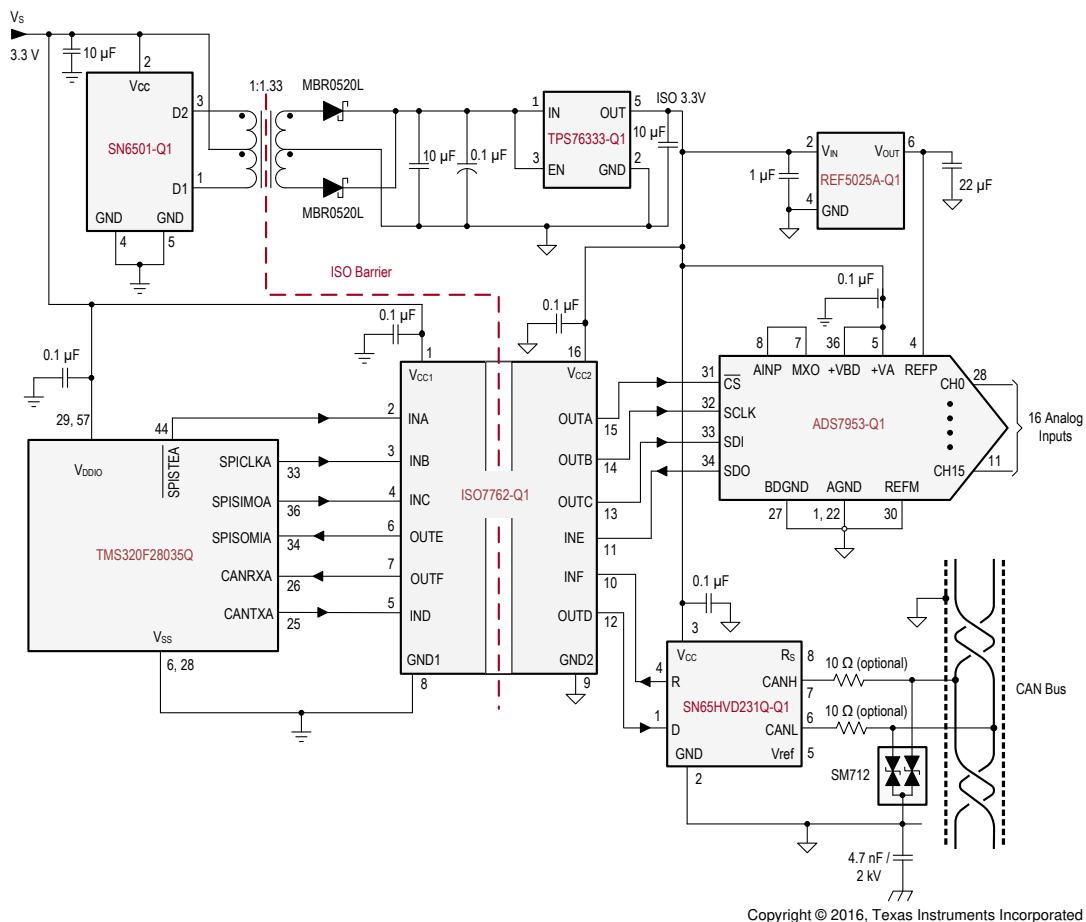

Copyright © 2016, Texas Instruments Incorporated

Multiple pins and discrete components omitted for clarity purpose.

Figure 8-1. Isolated SPI and CAN Interface

8.2.1 Design Requirements

For this design example, use the parameters listed in 表 8-1.

表 8-1. Design Parameters

PARAMETER	VALUE
Supply voltage, V_{CC1} and V_{CC2}	2.25 to 5.5 V
Decoupling capacitor between V_{CC1} and GND1	0.1 μF
Decoupling capacitor from V_{CC2} and GND2	0.1 μF

8.2.2 Detailed Design Procedure

Unlike optocouplers, which require external components to improve performance, provide bias, or limit current, the ISO776x-Q1 family of devices only requires two external bypass capacitors to operate.



図 8-2. Typical ISO7761-Q1 Circuit Hook-up

8.2.3 Application Curves

The typical eye diagram of the ISO776x-Q1 family of devices indicates low jitter and a wide open eye at the maximum data rate of 100 Mbps.

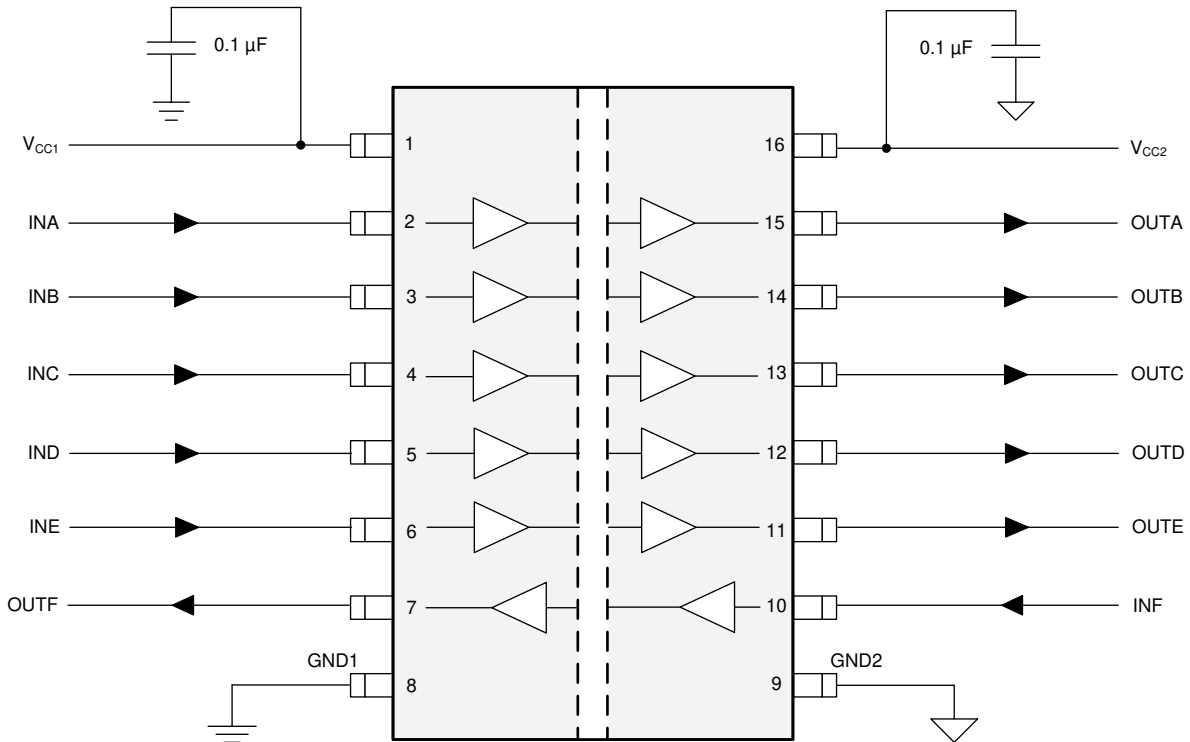
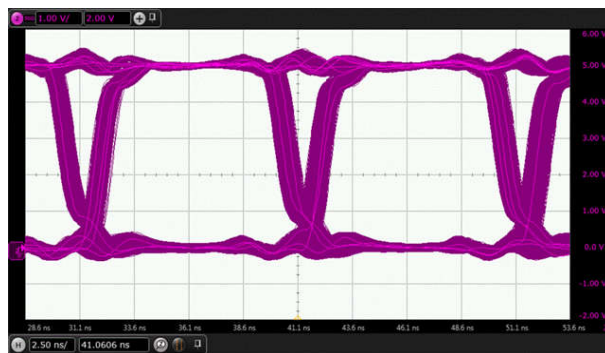

☒ 8-3. Eye Diagram at 100 Mbps PRBS 2¹⁶ – 1 Data, 5 V and 25°C

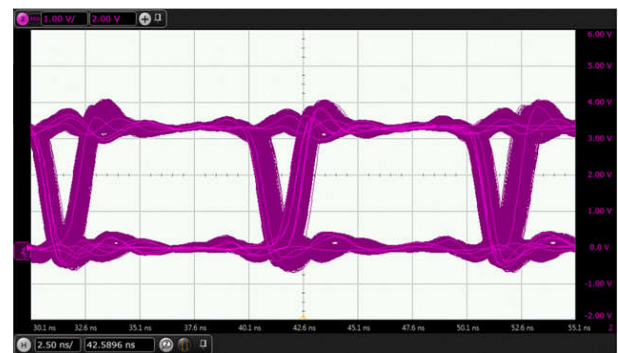

☒ 8-4. Eye Diagram at 100 Mbps PRBS 2¹⁶ – 1 Data, 3.3 V and 25°C

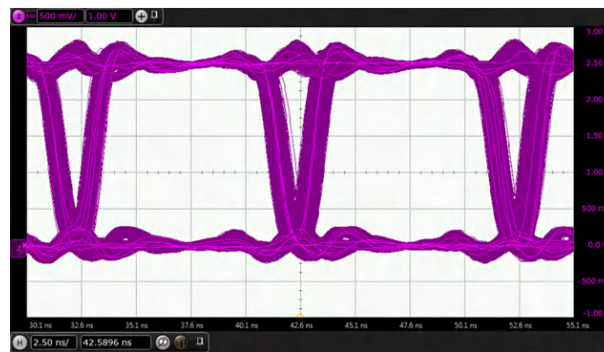

☒ 8-5. Eye Diagram at 100 Mbps PRBS 2¹⁶ – 1 Data, 2.5 V and 25°C

8.2.3.1 Insulation Lifetime

Insulation lifetime projection data is collected by using industry-standard Time Dependent Dielectric Breakdown (TDDB) test method. In this test, all pins on each side of the barrier are tied together creating a two-terminal device and high voltage applied between the two sides; See ☒ 8-6 for TDDB test setup. The insulation breakdown data is collected at various high voltages switching at 60 Hz over temperature. For reinforced insulation, VDE standard requires the use of TDDB projection line with failure rate of less than 1 part per million (ppm). Even though the expected minimum insulation lifetime is 20 years at the specified working isolation voltage, VDE reinforced certification requires additional safety margin of 20% for working voltage and 50% for lifetime which translates into minimum required insulation lifetime of 30 years at a working voltage that's 20% higher than the specified value.

☒ 8-7 shows the intrinsic capability of the isolation barrier to withstand high voltage stress over its lifetime. Based on the TDDB data, the intrinsic capability of the insulation is 1500 V_{RMS} with a lifetime of 36 years. Other factors, such as package size, pollution degree, material group, etc. can further limit the working voltage of the component. The working voltage of DW-16 package is specified upto 1500 V_{RMS} and DBQ-16 package up to 400 V_{RMS}. At the lower working voltages, the corresponding insulation lifetime is much longer than 36 years.

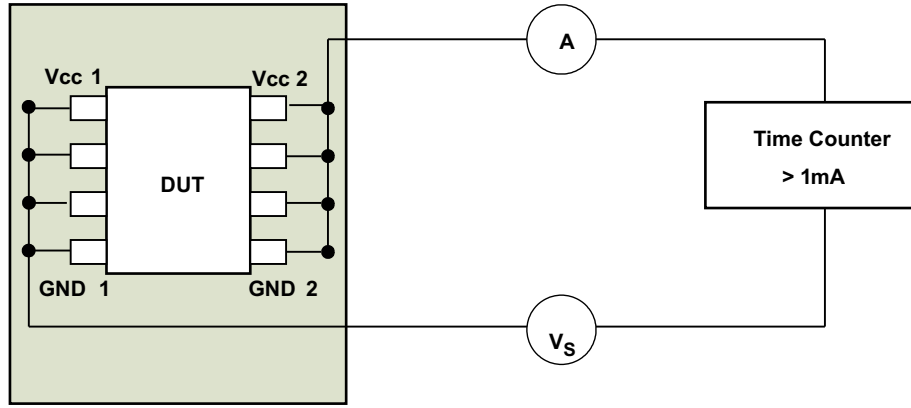

Oven at 150°C

8-6. Test Setup for Insulation Lifetime Measurement

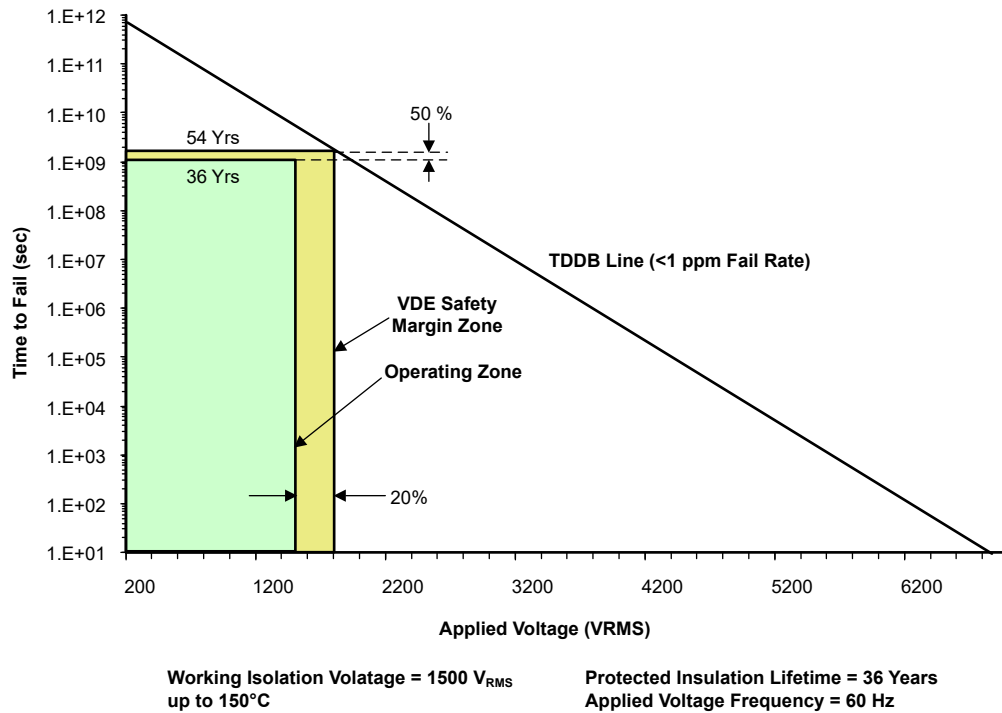

8-7. Insulation Lifetime Projection Data

9 Power Supply Recommendations

To help ensure reliable operation at data rates and supply voltages, a 0.1- μ F bypass capacitor is recommended at input and output supply pins (V_{CC1} and V_{CC2}). The capacitors should be placed as close to the supply pins as possible. If only a single primary-side power supply is available in an application, isolated power can be generated for the secondary-side with the help of a transformer driver such as Texas Instruments' [SN6501](#) or [SN6505](#). For such applications, detailed power supply design and transformer selection recommendations are available in the [SN6501 Transformer Driver for Isolated Power Supplies data sheet](#) or the [SN6505 Low-Noise 1-A Transformer Drivers for Isolated Power Supplies data sheet](#).

10 Layout

10.1 Layout Guidelines

A minimum of four layers is required to accomplish a low EMI PCB design (see [Figure 10-1](#)). Layer stacking should be in the following order (top-to-bottom): high-speed signal layer, ground plane, power plane and low-frequency signal layer.

- Routing the high-speed traces on the top layer avoids the use of vias (and the introduction of their inductances) and allows for clean interconnects between the isolator and the transmitter and receiver circuits of the data link.
- Placing a solid ground plane next to the high-speed signal layer establishes controlled impedance for transmission line interconnects and provides an excellent low-inductance path for the return current flow.
- Placing the power plane next to the ground plane creates additional high-frequency bypass capacitance of approximately 100 pF/inch².
- Routing the slower speed control signals on the bottom layer allows for greater flexibility as these signal links usually have margin to tolerate discontinuities such as vias.

If an additional supply voltage plane or signal layer is needed, add a second power or ground plane system to the stack to keep it symmetrical. This makes the stack mechanically stable and prevents it from warping. Also the power and ground plane of each power system can be placed closer together, thus increasing the high-frequency bypass capacitance significantly.

For detailed layout recommendations, see the [Digital Isolator Design Guide application report](#).

10.1.1 PCB Material

For digital circuit boards operating at less than 150 Mbps, (or rise and fall times greater than 1 ns), and trace lengths of up to 10 inches, use standard FR-4 UL94V-0 printed circuit board. This PCB is preferred over cheaper alternatives because of lower dielectric losses at high frequencies, less moisture absorption, greater strength and stiffness, and the self-extinguishing flammability-characteristics.

10.2 Layout Example

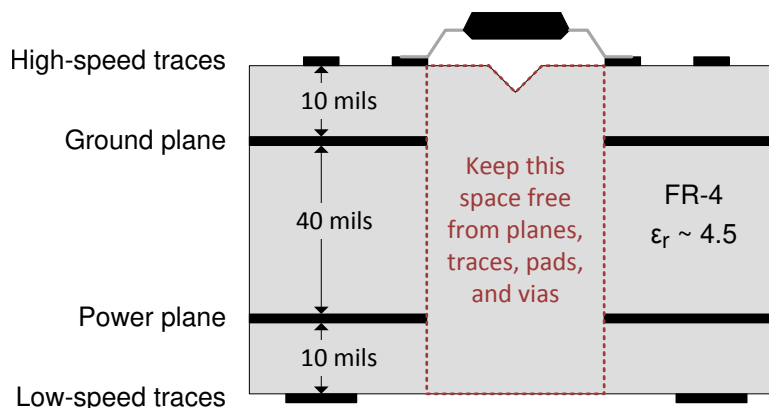

Figure 10-1. Layout Example Schematic

11 Device and Documentation Support

11.1 Documentation Support

11.1.1 Related Documentation

For related documentation see the following:

- Texas Instruments, [Digital Isolator Design Guide application report](#)
- Texas Instruments, [How to use isolation to improve ESD, EFT and Surge immunity in industrial systems application report](#)
- Texas Instruments, [Isolation Glossary](#)
- Texas Instruments, [TMS320F2803x Piccolo™ Microcontrollers data sheet](#)
- Texas Instruments, [ADS7953-Q1 Automotive 12-Bit, 1MSPS, 16-Channel Single-Ended Micropower, Serial Interface ADC data sheet](#)
- Texas Instruments, [REF50xxA-Q1 Low-Noise, Very Low Drift, Precision Voltage Reference data sheet](#)
- Texas Instruments, [SN6501-Q1 Transformer Driver for Isolated Power Supplies data sheet](#)
- Texas Instruments, [SN65HVD231Q-Q1 3.3-V CAN Transceiver data sheet](#)
- Texas Instruments, [TPS76333-Q1 Low-Power 150-mA Low-Dropout Linear Regulators data sheet](#)

11.2 Related Links

The table below lists quick access links. Categories include technical documents, support and community resources, tools and software, and quick access to sample or buy.

表 11-1. Related Links

PARTS	PRODUCT FOLDER	SAMPLE & BUY	TECHNICAL DOCUMENTS	TOOLS & SOFTWARE	SUPPORT & COMMUNITY
ISO7760-Q1	Click here	Click here	Click here	Click here	Click here
ISO7761-Q1	Click here	Click here	Click here	Click here	Click here
ISO7762-Q1	Click here	Click here	Click here	Click here	Click here
ISO7763-Q1	Click here	Click here	Click here	Click here	Click here

11.3 Receiving Notification of Documentation Updates

To receive notification of documentation updates, navigate to the device product folder on ti.com. In the upper right corner, click on *Alert me* to register and receive a weekly digest of any product information that has changed. For change details, review the revision history included in any revised document.

11.4 サポート・リソース

テキサス・インスツルメンツ E2E™ サポート・フォーラムは、エンジニアが検証済みの回答と設計に関するヒントをエキスパートから迅速かつ直接得ることができる場所です。既存の回答を検索したり、独自の質問をしたりすることで、設計に必要な支援を迅速に得ることができます。

リンクされているコンテンツは、各寄稿者により「現状のまま」提供されるものです。これらはテキサス・インスツルメンツの仕様を構成するものではなく、必ずしもテキサス・インスツルメンツの見解を反映したものではありません。テキサス・インスツルメンツの[使用条件](#)を参照してください。

11.5 Trademarks

Piccolo™ is a trademark of Texas Instruments.

テキサス・インスツルメンツ E2E™ is a trademark of Texas Instruments.

すべての商標は、それぞれの所有者に帰属します。

11.6 静電気放電に関する注意事項



この IC は、ESD によって破損する可能性があります。テキサス・インスツルメンツは、IC を取り扱う際には常に適切な注意を払うことを推奨します。正しい取り扱いおよび設置手順に従わない場合、デバイスを破損するおそれがあります。

ESD による破損は、わずかな性能低下からデバイスの完全な故障まで多岐にわたります。精密な IC の場合、パラメータがわずかに変化するだけで公表されている仕様から外れる可能性があるため、破損が発生しやすくなっています。

11.7 用語集

テキサス・インスツルメンツ用語集 この用語集には、用語や略語の一覧および定義が記載されています。

12 Revision History

資料番号末尾の英字は改訂を表しています。その改訂履歴は英語版に準じています。

Changes from Revision D (January 2024) to Revision E (July 2024)	Page
ドキュメント全体にわたって表、図、相互参照の採番方法を更新.....	1
Updated Thermal Characteristics, Safety Limiting Values, and Thermal Derating Curves to provide more accurate system-level thermal calculations.....	8
Changed CPG parameter description from "External clearance" to "External creepage".....	9
Updated electrical and switching characteristics to match device performance.....	13

Changes from Revision C (October 2022) to Revision D (January 2024)	Page
Added table note to Data rate specification.....	7
Changed V_{IORM} value for DW-16 package from "1414 V_{PK} " to "2121 V_{PK} ".....	9
Changed V_{IOWM} values for DW-16 package from "1000 V_{RMS} " and "1414 V_{DC} " to "1500 V_{RMS} " and "2121 V_{DC} ".....	9
Updated certification information.....	11

Changes from Revision B (October 2020) to Revision C (October 2022)	Page
ドキュメント全体にわたって表、図、相互参照の採番方法を更新.....	1
ドキュメント全体を通して標準名を以下のように変更:「DIN V VDE V 0884-11:2017-01」から次のものに変更:「DIN EN IEC 60747-17 (VDE 0884-17)」.....	1
ドキュメント全体を通して、IEC/EN/CSA 60950-1 規格への参照を削除.....	1
Updated Thermal characteristics, Safety Limiting Values, and Thermal derating Curves to provide more accurate system-level thermal calculations.....	6
Updated electrical and switching characteristics to match device performance.....	6
Changed the C_{IO} value for the DBQ package from 1.1 to 0.9 pF.....	9
Changed working voltage lifetime margin From: 87.5% To: 50%, minimum required insulation lifetime From: 37.5 years To: 30 years and insulation lifetime per TDDB From: 135 years To: 169 years in Insulation Lifetime per DIN EN IEC 60747-17 (VDE 0884-17).....	32
Changed Figure 9-7 per DIN EN IEC 60747-17 (VDE 0884-17).....	32

Changes from Revision A (February 2019) to Revision B (October 2020)	Page
機能安全の箇条書き項目を追加.....	1
Added the maximum transient isolation voltage for the DW-16 package of the ISO7761, ISO7762, and ISO7763 devices and changed the maximum value for the DBQ-16 package from 3600 to 4242 for all devices.....	9
Changed table note and table condition of safety limiting values.....	11

13 Mechanical, Packaging, and Orderable Information

The following pages include mechanical, packaging, and orderable information. This information is the most current data available for the designated devices. This data is subject to change without notice and revision of this document. For browser-based versions of this data sheet, refer to the left-hand navigation.

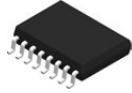

DW0016B

PACKAGE OUTLINE
SOIC - 2.65 mm max height

SOIC

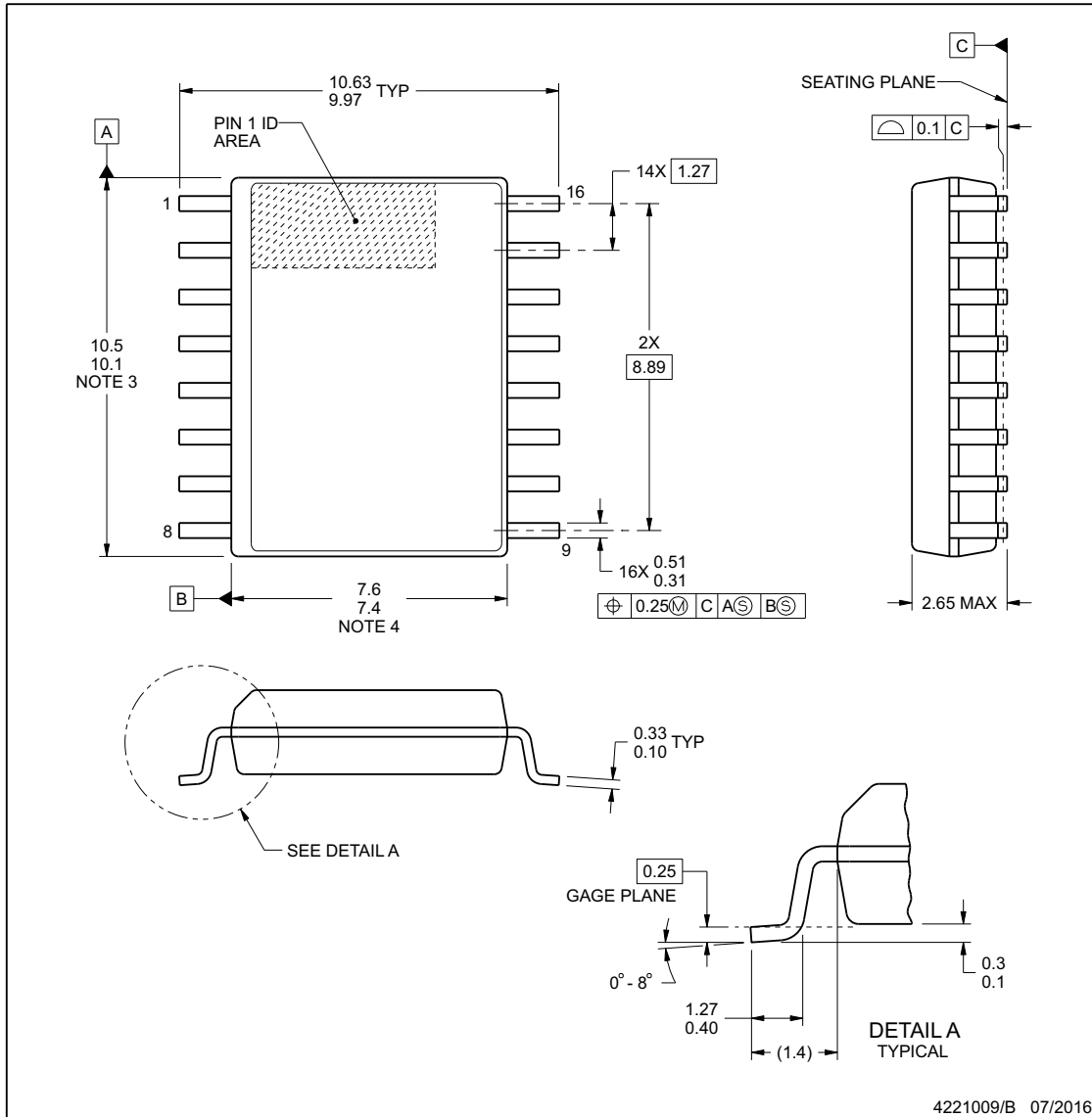

4221009/B 07/2016

NOTES:

1. All linear dimensions are in millimeters. Dimensions in parenthesis are for reference only. Dimensioning and tolerancing per ASME Y14.5M.
2. This drawing is subject to change without notice.
3. This dimension does not include mold flash, protrusions, or gate burrs. Mold flash, protrusions, or gate burrs shall not exceed 0.15 mm, per side.
4. This dimension does not include interlead flash. Interlead flash shall not exceed 0.25 mm, per side.
5. Reference JEDEC registration MS-013.

www.ti.com

EXAMPLE BOARD LAYOUT

DW0016B

SOIC - 2.65 mm max height

SOIC

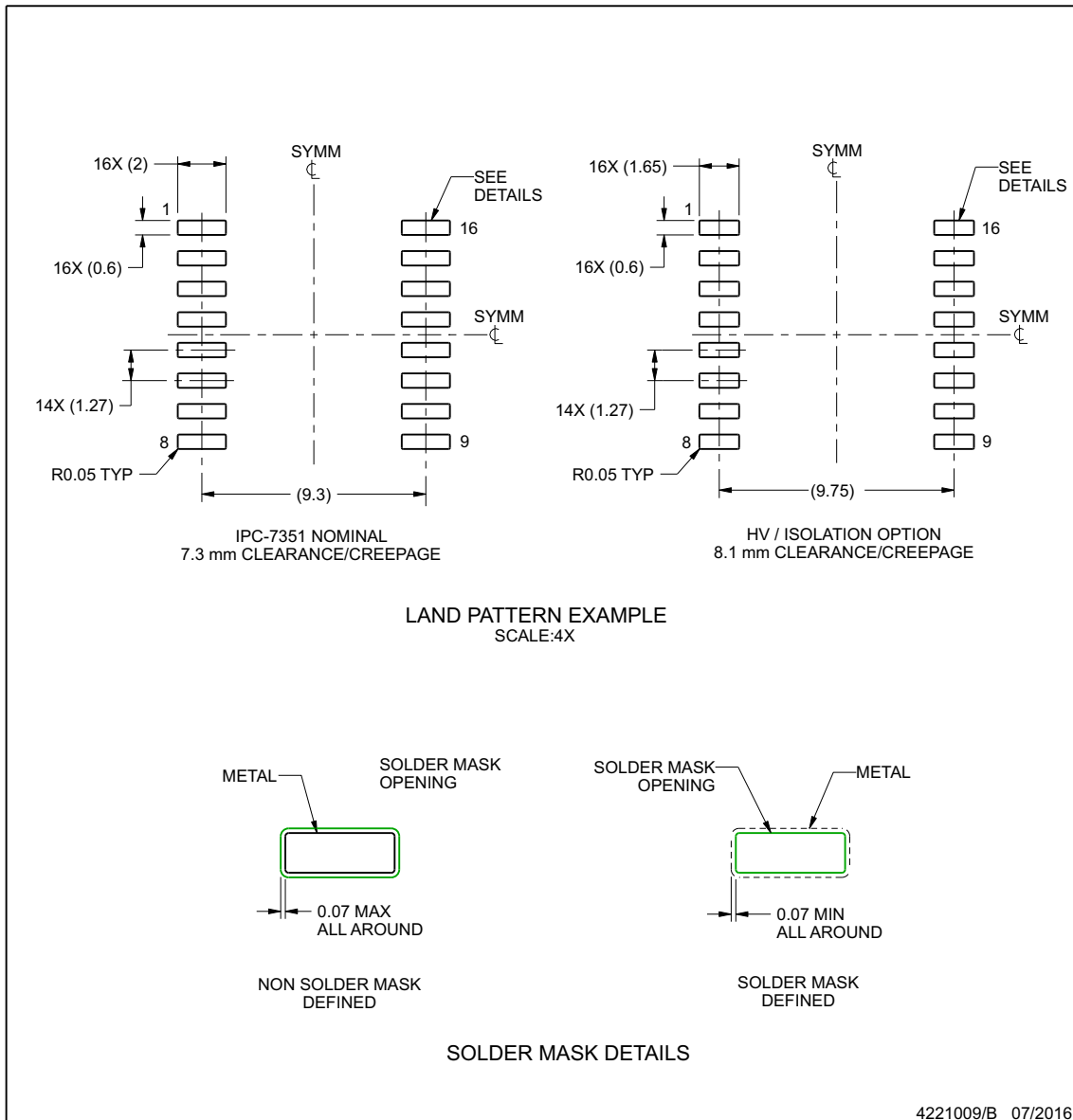

NOTES: (continued)

- 6. Publication IPC-7351 may have alternate designs.
- 7. Solder mask tolerances between and around signal pads can vary based on board fabrication site.

www.ti.com

EXAMPLE STENCIL DESIGN

DW0016B

SOIC - 2.65 mm max height

SOIC

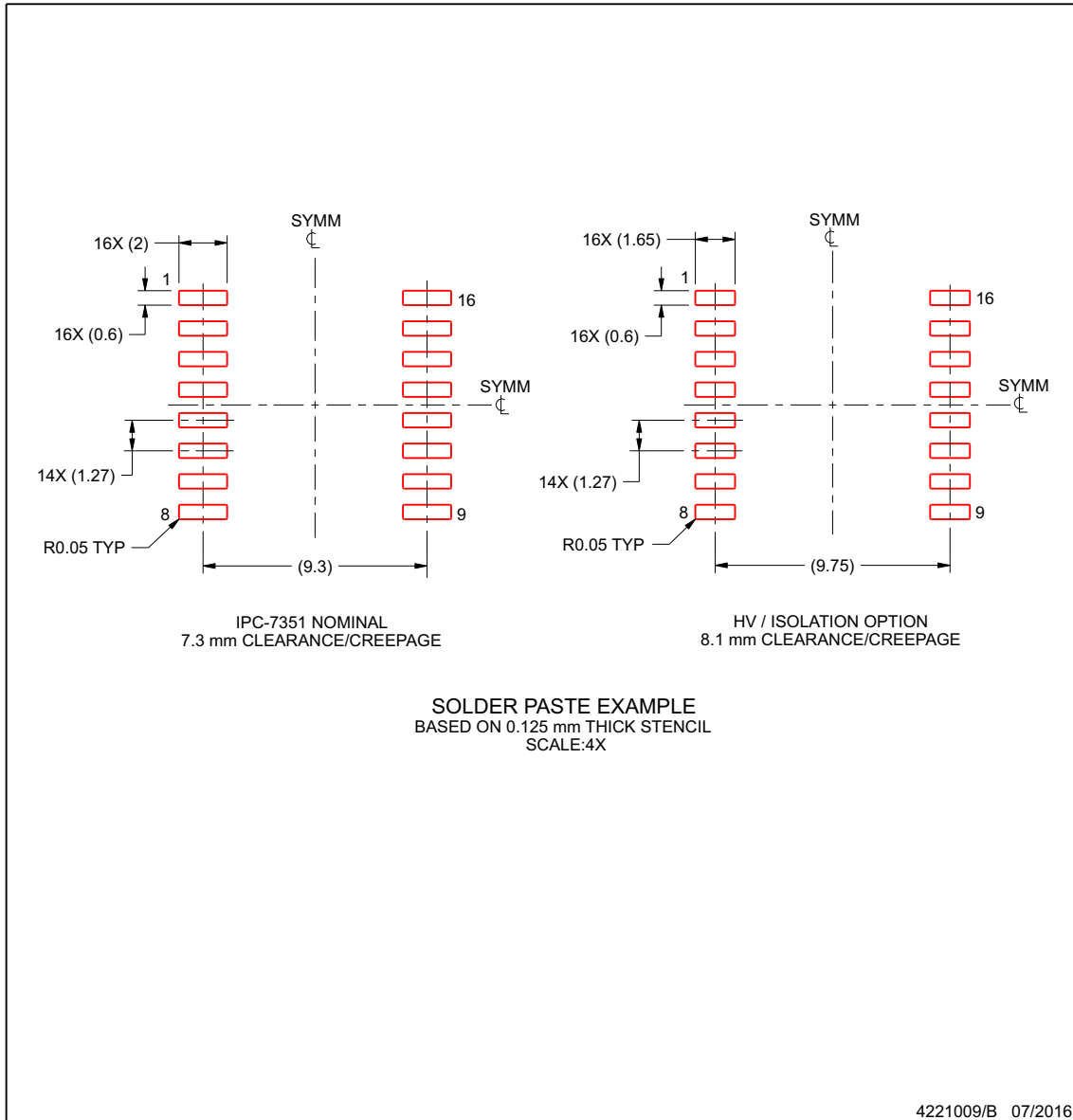

NOTES: (continued)

8. Laser cutting apertures with trapezoidal walls and rounded corners may offer better paste release. IPC-7525 may have alternate design recommendations.
9. Board assembly site may have different recommendations for stencil design.

www.ti.com

重要なお知らせと免責事項

テキサス・インスツルメンツは、技術データと信頼性データ (データシートを含みます)、設計リソース (リファレンス デザインを含みます)、アプリケーションや設計に関する各種アドバイス、Web ツール、安全性情報、その他のリソースを、欠陥が存在する可能性のある「現状のまま」提供しており、商品性および特定目的に対する適合性の黙示保証、第三者の知的財産権の非侵害保証を含むいかなる保証も、明示的または黙示的にかかわらず拒否します。

これらのリソースは、テキサス・インスツルメンツ製品を使用する設計の経験を積んだ開発者への提供を意図したものです。(1) お客様のアプリケーションに適した テキサス・インスツルメンツ製品の選定、(2) お客様のアプリケーションの設計、検証、試験、(3) お客様のアプリケーションに該当する各種規格や、その他のあらゆる安全性、セキュリティ、規制、または他の要件への確実な適合に関する責任を、お客様のみが単独で負うものとします。

上記の各種リソースは、予告なく変更される可能性があります。これらのリソースは、リソースで説明されている テキサス・インスツルメンツ製品を使用するアプリケーションの開発の目的でのみ、テキサス・インスツルメンツはその使用をお客様に許諾します。これらのリソースに関して、他の目的で複製することや掲載することは禁止されています。テキサス・インスツルメンツや第三者の知的財産権のライセンスが付与されている訳ではありません。お客様は、これらのリソースを自身で使用した結果発生するあらゆる申し立て、損害、費用、損失、責任について、テキサス・インスツルメンツおよびその代理人を完全に補償するものとし、テキサス・インスツルメンツは一切の責任を拒否します。

テキサス・インスツルメンツの製品は、[テキサス・インスツルメンツの販売条件](#)、または [ti.com](https://www.ti.com) やかかる テキサス・インスツルメンツ製品の関連資料などのいずれかを通じて提供する適用可能な条項の下で提供されています。テキサス・インスツルメンツがこれらのリソースを提供することは、適用されるテキサス・インスツルメンツの保証または他の保証の放棄の拡大や変更を意味するものではありません。

お客様がいかなる追加条項または代替条項を提案した場合でも、テキサス・インスツルメンツはそれらに異議を唱え、拒否します。

郵送先住所: Texas Instruments, Post Office Box 655303, Dallas, Texas 75265

Copyright © 2024, Texas Instruments Incorporated

PACKAGING INFORMATION

Orderable part number	Status (1)	Material type (2)	Package Pins	Package qty Carrier	RoHS (3)	Lead finish/ Ball material (4)	MSL rating/ Peak reflow (5)	Op temp (°C)	Part marking (6)
ISO7760FQDBQRQ1	Active	Production	SSOP (DBQ) 16	2500 LARGE T&R	Yes	NIPDAU	Level-2-260C-1 YEAR	-40 to 125	(7760F, 7760FQ)
ISO7760FQDBQRQ1.A	Active	Production	SSOP (DBQ) 16	2500 LARGE T&R	Yes	NIPDAU	Level-2-260C-1 YEAR	-40 to 125	(7760F, 7760FQ)
ISO7760FQDWRQ1	Active	Production	SOIC (DW) 16	2000 LARGE T&R	Yes	NIPDAU	Level-2-260C-1 YEAR	-40 to 125	(ISO7760F, ISO7760FQ)
ISO7760FQDWRQ1.A	Active	Production	SOIC (DW) 16	2000 LARGE T&R	Yes	NIPDAU	Level-2-260C-1 YEAR	-40 to 125	(ISO7760F, ISO7760FQ)
ISO7760QDBQRQ1	Active	Production	SSOP (DBQ) 16	2500 LARGE T&R	Yes	NIPDAU	Level-2-260C-1 YEAR	-40 to 125	(7760, 7760Q)
ISO7760QDBQRQ1.A	Active	Production	SSOP (DBQ) 16	2500 LARGE T&R	Yes	NIPDAU	Level-2-260C-1 YEAR	-40 to 125	(7760, 7760Q)
ISO7760QDWRQ1	Active	Production	SOIC (DW) 16	2000 LARGE T&R	Yes	NIPDAU	Level-2-260C-1 YEAR	-40 to 125	(ISO7760, ISO7760Q)
ISO7760QDWRQ1.A	Active	Production	SOIC (DW) 16	2000 LARGE T&R	Yes	NIPDAU	Level-2-260C-1 YEAR	-40 to 125	(ISO7760, ISO7760Q)
ISO7761FQDBQRQ1	Active	Production	SSOP (DBQ) 16	2500 LARGE T&R	Yes	NIPDAU	Level-2-260C-1 YEAR	-40 to 125	(7761F, 7761FQ)
ISO7761FQDBQRQ1.A	Active	Production	SSOP (DBQ) 16	2500 LARGE T&R	Yes	NIPDAU	Level-2-260C-1 YEAR	-40 to 125	(7761F, 7761FQ)
ISO7761FQDWRQ1	Active	Production	SOIC (DW) 16	2000 LARGE T&R	Yes	NIPDAU	Level-2-260C-1 YEAR	-40 to 125	(ISO7761F, ISO7761FQ)
ISO7761FQDWRQ1.A	Active	Production	SOIC (DW) 16	2000 LARGE T&R	Yes	NIPDAU	Level-2-260C-1 YEAR	-40 to 125	(ISO7761F, ISO7761FQ)
ISO7761QDBQRQ1	Active	Production	SSOP (DBQ) 16	2500 LARGE T&R	Yes	NIPDAU	Level-2-260C-1 YEAR	-40 to 125	(7761, 7761Q)
ISO7761QDBQRQ1.A	Active	Production	SSOP (DBQ) 16	2500 LARGE T&R	Yes	NIPDAU	Level-2-260C-1 YEAR	-40 to 125	(7761, 7761Q)
ISO7761QDWRQ1	Active	Production	SOIC (DW) 16	2000 LARGE T&R	Yes	NIPDAU	Level-2-260C-1 YEAR	-40 to 125	(ISO7761, ISO7761Q)
ISO7761QDWRQ1.A	Active	Production	SOIC (DW) 16	2000 LARGE T&R	Yes	NIPDAU	Level-2-260C-1 YEAR	-40 to 125	(ISO7761, ISO7761Q)
ISO7762FQDBQRQ1	Active	Production	SSOP (DBQ) 16	2500 LARGE T&R	Yes	NIPDAU	Level-2-260C-1 YEAR	-40 to 125	(7762F, 7762FQ)
ISO7762FQDBQRQ1.A	Active	Production	SSOP (DBQ) 16	2500 LARGE T&R	Yes	NIPDAU	Level-2-260C-1 YEAR	-40 to 125	(7762F, 7762FQ)
ISO7762FQDWRQ1	Active	Production	SOIC (DW) 16	2000 LARGE T&R	Yes	NIPDAU	Level-2-260C-1 YEAR	-40 to 125	(ISO7762F, ISO7762FQ)
ISO7762FQDWRQ1.A	Active	Production	SOIC (DW) 16	2000 LARGE T&R	Yes	NIPDAU	Level-2-260C-1 YEAR	-40 to 125	(ISO7762F, ISO7762FQ)
ISO7762QDBQRQ1	Active	Production	SSOP (DBQ) 16	2500 LARGE T&R	Yes	NIPDAU	Level-2-260C-1 YEAR	-40 to 125	(7762, 7762Q)
ISO7762QDBQRQ1.A	Active	Production	SSOP (DBQ) 16	2500 LARGE T&R	Yes	NIPDAU	Level-2-260C-1 YEAR	-40 to 125	(7762, 7762Q)

Orderable part number	Status (1)	Material type (2)	Package Pins	Package qty Carrier	RoHS (3)	Lead finish/ Ball material (4)	MSL rating/ Peak reflow (5)	Op temp (°C)	Part marking (6)
ISO7762QDWRQ1	Active	Production	SOIC (DW) 16	2000 LARGE T&R	Yes	NIPDAU	Level-2-260C-1 YEAR	-40 to 125	(ISO7762, ISO7762Q)
ISO7762QDWRQ1.A	Active	Production	SOIC (DW) 16	2000 LARGE T&R	Yes	NIPDAU	Level-2-260C-1 YEAR	-40 to 125	(ISO7762, ISO7762Q)
ISO7763FQDBQRQ1	Active	Production	SSOP (DBQ) 16	2500 LARGE T&R	Yes	NIPDAU	Level-2-260C-1 YEAR	-40 to 125	(7763F, 7763FQ)
ISO7763FQDBQRQ1.A	Active	Production	SSOP (DBQ) 16	2500 LARGE T&R	Yes	NIPDAU	Level-2-260C-1 YEAR	-40 to 125	(7763F, 7763FQ)
ISO7763FQDWRQ1	Active	Production	SOIC (DW) 16	2000 LARGE T&R	Yes	NIPDAU	Level-2-260C-1 YEAR	-40 to 125	(ISO7763F, ISO7763 FQ)
ISO7763FQDWRQ1.A	Active	Production	SOIC (DW) 16	2000 LARGE T&R	Yes	NIPDAU	Level-2-260C-1 YEAR	-40 to 125	(ISO7763F, ISO7763 FQ)
ISO7763QDBQRQ1	Active	Production	SSOP (DBQ) 16	2500 LARGE T&R	Yes	NIPDAU	Level-2-260C-1 YEAR	-40 to 125	(7763, 7763Q)
ISO7763QDBQRQ1.A	Active	Production	SSOP (DBQ) 16	2500 LARGE T&R	Yes	NIPDAU	Level-2-260C-1 YEAR	-40 to 125	(7763, 7763Q)
ISO7763QDWRQ1	Active	Production	SOIC (DW) 16	2000 LARGE T&R	Yes	NIPDAU	Level-2-260C-1 YEAR	-40 to 125	(ISO7763, ISO7763Q)
ISO7763QDWRQ1.A	Active	Production	SOIC (DW) 16	2000 LARGE T&R	Yes	NIPDAU	Level-2-260C-1 YEAR	-40 to 125	(ISO7763, ISO7763Q)

(1) **Status:** For more details on status, see our [product life cycle](#).

(2) **Material type:** When designated, preproduction parts are prototypes/experimental devices, and are not yet approved or released for full production. Testing and final process, including without limitation quality assurance, reliability performance testing, and/or process qualification, may not yet be complete, and this item is subject to further changes or possible discontinuation. If available for ordering, purchases will be subject to an additional waiver at checkout, and are intended for early internal evaluation purposes only. These items are sold without warranties of any kind.

(3) **RoHS values:** Yes, No, RoHS Exempt. See the [TI RoHS Statement](#) for additional information and value definition.

(4) **Lead finish/Ball material:** Parts may have multiple material finish options. Finish options are separated by a vertical ruled line. Lead finish/Ball material values may wrap to two lines if the finish value exceeds the maximum column width.

(5) **MSL rating/Peak reflow:** The moisture sensitivity level ratings and peak solder (reflow) temperatures. In the event that a part has multiple moisture sensitivity ratings, only the lowest level per JEDEC standards is shown. Refer to the shipping label for the actual reflow temperature that will be used to mount the part to the printed circuit board.

(6) **Part marking:** There may be an additional marking, which relates to the logo, the lot trace code information, or the environmental category of the part.

Multiple part markings will be inside parentheses. Only one part marking contained in parentheses and separated by a "~" will appear on a part. If a line is indented then it is a continuation of the previous line and the two combined represent the entire part marking for that device.

Important Information and Disclaimer: The information provided on this page represents TI's knowledge and belief as of the date that it is provided. TI bases its knowledge and belief on information provided by third parties, and makes no representation or warranty as to the accuracy of such information. Efforts are underway to better integrate information from third parties. TI has taken and continues to take reasonable steps to provide representative and accurate information but may not have conducted destructive testing or chemical analysis on incoming materials and chemicals. TI and TI suppliers consider certain information to be proprietary, and thus CAS numbers and other limited information may not be available for release.

In no event shall TI's liability arising out of such information exceed the total purchase price of the TI part(s) at issue in this document sold by TI to Customer on an annual basis.

OTHER QUALIFIED VERSIONS OF ISO7760-Q1, ISO7761-Q1, ISO7762-Q1, ISO7763-Q1 :

- Catalog : [ISO7760](#), [ISO7761](#), [ISO7762](#), [ISO7763](#)

NOTE: Qualified Version Definitions:

- Catalog - TI's standard catalog product

TAPE AND REEL INFORMATION



QUADRANT ASSIGNMENTS FOR PIN 1 ORIENTATION IN TAPE



*All dimensions are nominal

Device	Package Type	Package Drawing	Pins	SPQ	Reel Diameter (mm)	Reel Width W1 (mm)	A0 (mm)	B0 (mm)	K0 (mm)	P1 (mm)	W (mm)	Pin1 Quadrant
ISO7760FQDBQRQ1	SSOP	DBQ	16	2500	330.0	12.4	6.4	5.2	2.1	8.0	12.0	Q1
ISO7760FQDWRQ1	SOIC	DW	16	2000	330.0	16.4	10.75	10.7	2.7	12.0	16.0	Q1
ISO7760FQDWRQ1	SOIC	DW	16	2000	330.0	16.4	10.75	10.7	2.7	12.0	16.0	Q1
ISO7760QDBQRQ1	SSOP	DBQ	16	2500	330.0	12.4	6.4	5.2	2.1	8.0	12.0	Q1
ISO7760QDWRQ1	SOIC	DW	16	2000	330.0	16.4	10.75	10.7	2.7	12.0	16.0	Q1
ISO7760QDWRQ1	SOIC	DW	16	2000	330.0	16.4	10.75	10.7	2.7	12.0	16.0	Q1
ISO7761FQDBQRQ1	SSOP	DBQ	16	2500	330.0	12.4	6.4	5.2	2.1	8.0	12.0	Q1
ISO7761FQDWRQ1	SOIC	DW	16	2000	330.0	16.4	10.75	10.7	2.7	12.0	16.0	Q1
ISO7761QDBQRQ1	SSOP	DBQ	16	2500	330.0	12.4	6.4	5.2	2.1	8.0	12.0	Q1
ISO7761QDBQRQ1	SSOP	DBQ	16	2500	330.0	12.4	6.4	5.2	2.1	8.0	12.0	Q1
ISO7761QDWRQ1	SOIC	DW	16	2000	330.0	16.4	10.75	10.7	2.7	12.0	16.0	Q1
ISO7761QDWRQ1	SOIC	DW	16	2000	330.0	16.4	10.75	10.7	2.7	12.0	16.0	Q1
ISO7762FQDBQRQ1	SSOP	DBQ	16	2500	330.0	12.4	6.4	5.2	2.1	8.0	12.0	Q1
ISO7762FQDWRQ1	SOIC	DW	16	2000	330.0	16.4	10.75	10.7	2.7	12.0	16.0	Q1
ISO7762FQDWRQ1	SOIC	DW	16	2000	330.0	16.4	10.75	10.7	2.7	12.0	16.0	Q1
ISO7762QDBQRQ1	SSOP	DBQ	16	2500	330.0	12.4	6.4	5.2	2.1	8.0	12.0	Q1

Device	Package Type	Package Drawing	Pins	SPQ	Reel Diameter (mm)	Reel Width W1 (mm)	A0 (mm)	B0 (mm)	K0 (mm)	P1 (mm)	W (mm)	Pin1 Quadrant
ISO7762QDWRQ1	SOIC	DW	16	2000	330.0	16.4	10.75	10.7	2.7	12.0	16.0	Q1
ISO7763FQDBQRQ1	SSOP	DBQ	16	2500	330.0	12.4	6.4	5.2	2.1	8.0	12.0	Q1
ISO7763FQDBQRQ1	SSOP	DBQ	16	2500	330.0	12.4	6.4	5.2	2.1	8.0	12.0	Q1
ISO7763FQDWRQ1	SOIC	DW	16	2000	330.0	16.4	10.75	10.7	2.7	12.0	16.0	Q1
ISO7763QDBQRQ1	SSOP	DBQ	16	2500	330.0	12.4	6.4	5.2	2.1	8.0	12.0	Q1
ISO7763QDWRQ1	SOIC	DW	16	2000	330.0	16.4	10.75	10.7	2.7	12.0	16.0	Q1
ISO7763QDWRQ1	SOIC	DW	16	2000	330.0	16.4	10.75	10.7	2.7	12.0	16.0	Q1

TAPE AND REEL BOX DIMENSIONS

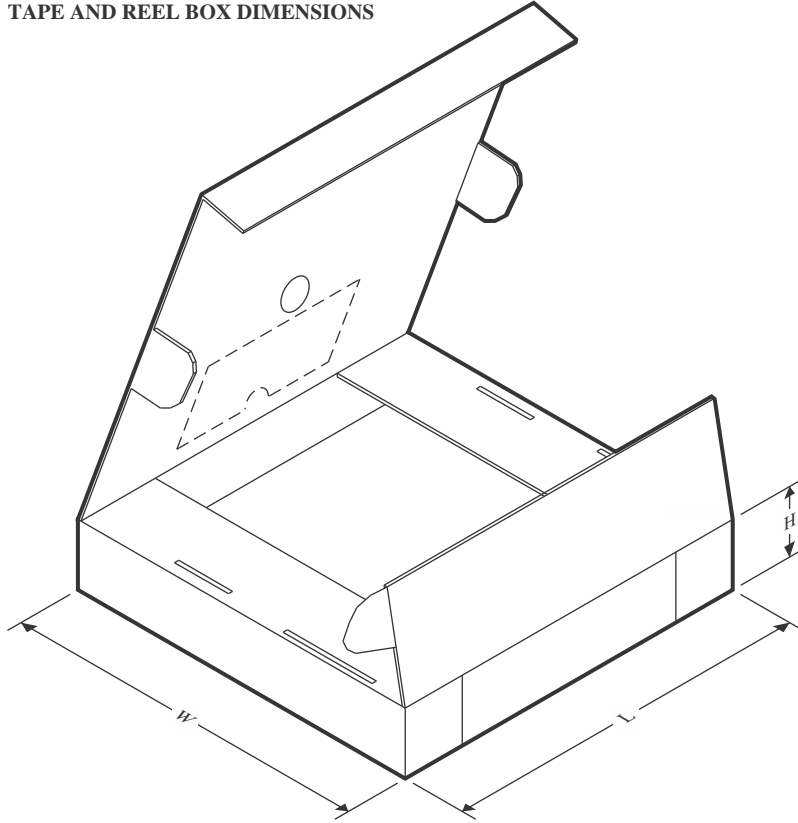

*All dimensions are nominal

Device	Package Type	Package Drawing	Pins	SPQ	Length (mm)	Width (mm)	Height (mm)
ISO7760FQDBQRQ1	SSOP	DBQ	16	2500	353.0	353.0	32.0
ISO7760FQDWRQ1	SOIC	DW	16	2000	356.0	356.0	36.0
ISO7760FQDWRQ1	SOIC	DW	16	2000	353.0	353.0	32.0
ISO7760QDBQRQ1	SSOP	DBQ	16	2500	353.0	353.0	32.0
ISO7760QDWRQ1	SOIC	DW	16	2000	353.0	353.0	32.0
ISO7760QDWRQ1	SOIC	DW	16	2000	356.0	356.0	36.0
ISO7761FQDBQRQ1	SSOP	DBQ	16	2500	353.0	353.0	32.0
ISO7761FQDWRQ1	SOIC	DW	16	2000	353.0	353.0	32.0
ISO7761QDBQRQ1	SSOP	DBQ	16	2500	367.0	367.0	38.0
ISO7761QDBQRQ1	SSOP	DBQ	16	2500	353.0	353.0	32.0
ISO7761QDWRQ1	SOIC	DW	16	2000	356.0	356.0	36.0
ISO7761QDWRQ1	SOIC	DW	16	2000	353.0	353.0	32.0
ISO7762FQDBQRQ1	SSOP	DBQ	16	2500	367.0	367.0	38.0
ISO7762FQDWRQ1	SOIC	DW	16	2000	353.0	353.0	32.0
ISO7762FQDWRQ1	SOIC	DW	16	2000	356.0	356.0	36.0
ISO7762QDBQRQ1	SSOP	DBQ	16	2500	353.0	353.0	32.0
ISO7762QDWRQ1	SOIC	DW	16	2000	353.0	353.0	32.0
ISO7763FQDBQRQ1	SSOP	DBQ	16	2500	353.0	353.0	32.0

Device	Package Type	Package Drawing	Pins	SPQ	Length (mm)	Width (mm)	Height (mm)
ISO7763FQDBQRQ1	SSOP	DBQ	16	2500	350.0	350.0	43.0
ISO7763FQDWRQ1	SOIC	DW	16	2000	353.0	353.0	32.0
ISO7763QDBQRQ1	SSOP	DBQ	16	2500	353.0	353.0	32.0
ISO7763QDWRQ1	SOIC	DW	16	2000	353.0	353.0	32.0
ISO7763QDWRQ1	SOIC	DW	16	2000	350.0	350.0	43.0

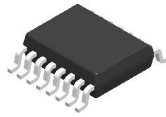

DBQ0016A

PACKAGE OUTLINE

SSOP - 1.75 mm max height

SHRINK SMALL-OUTLINE PACKAGE

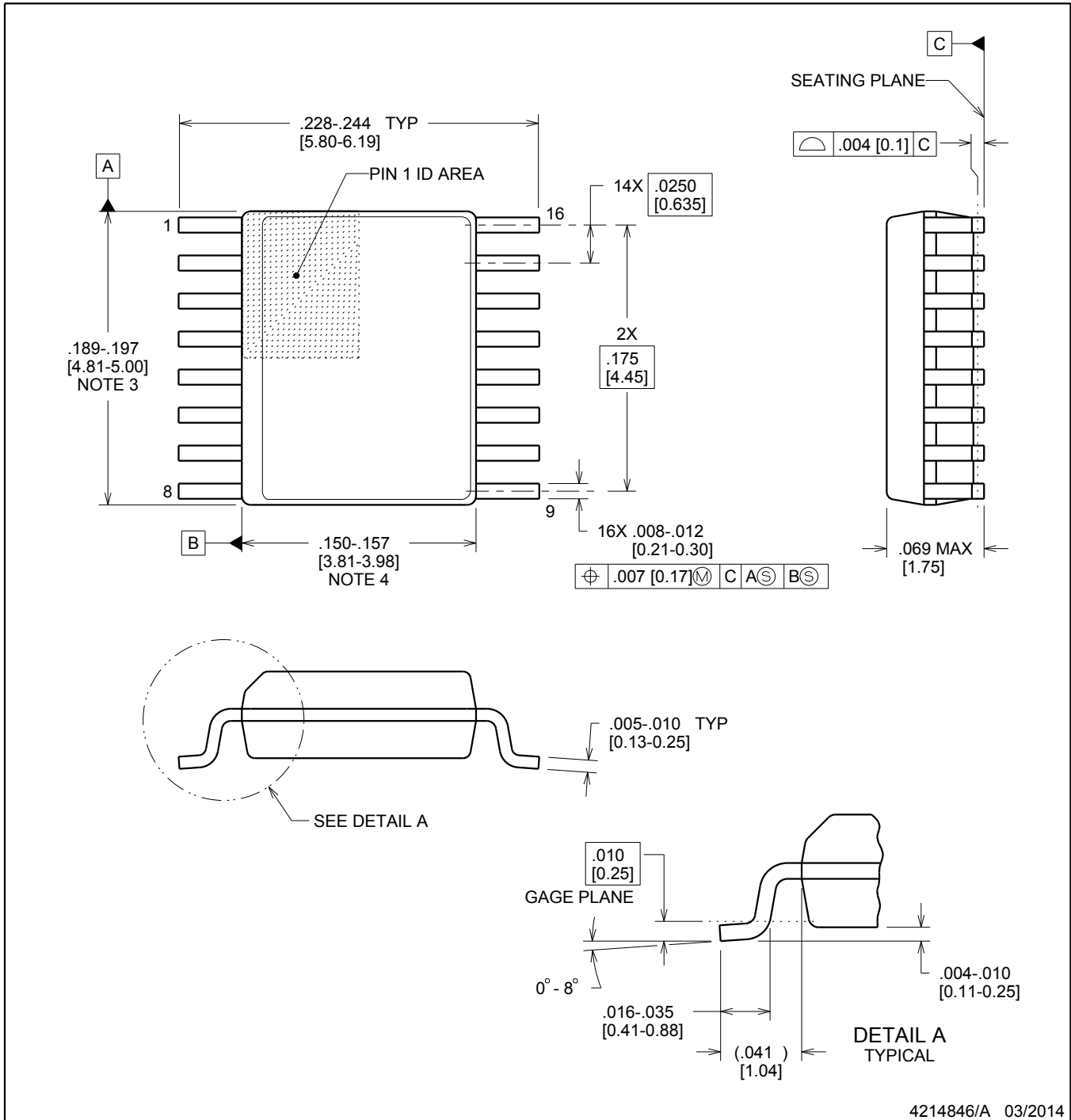

4214846/A 03/2014

NOTES:

- Linear dimensions are in inches [millimeters]. Dimensions in parenthesis are for reference only. Controlling dimensions are in inches. Dimensioning and tolerancing per ASME Y14.5M.
- This drawing is subject to change without notice.
- This dimension does not include mold flash, protrusions, or gate burrs. Mold flash, protrusions, or gate burrs shall not exceed .006 inch, per side.
- This dimension does not include interlead flash.
- Reference JEDEC registration MO-137, variation AB.

EXAMPLE BOARD LAYOUT

DBQ0016A

SSOP - 1.75 mm max height

SHRINK SMALL-OUTLINE PACKAGE

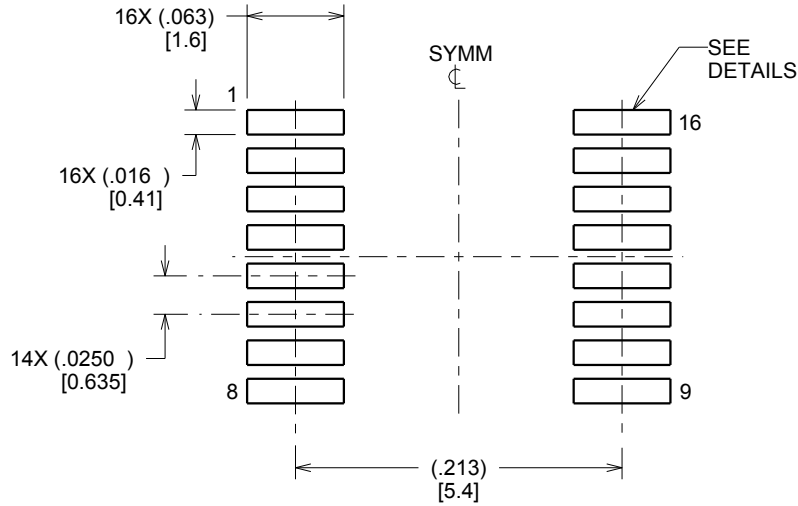

LAND PATTERN EXAMPLE
SCALE:8X



SOLDER MASK DETAILS

4214846/A 03/2014

NOTES: (continued)

6. Publication IPC-7351 may have alternate designs.

7. Solder mask tolerances between and around signal pads can vary based on board fabrication site.

EXAMPLE STENCIL DESIGN

DBQ0016A

SSOP - 1.75 mm max height

SHRINK SMALL-OUTLINE PACKAGE



SOLDER PASTE EXAMPLE
BASED ON .005 INCH [0.127 MM] THICK STENCIL
SCALE:8X

4214846/A 03/2014

NOTES: (continued)

8. Laser cutting apertures with trapezoidal walls and rounded corners may offer better paste release. IPC-7525 may have alternate design recommendations.
9. Board assembly site may have different recommendations for stencil design.

GENERIC PACKAGE VIEW

DW 16

SOIC - 2.65 mm max height

7.5 x 10.3, 1.27 mm pitch

SMALL OUTLINE INTEGRATED CIRCUIT

This image is a representation of the package family, actual package may vary.
Refer to the product data sheet for package details.



4224780/A



DW0016B

PACKAGE OUTLINE

SOIC - 2.65 mm max height

SOIC



4221009/B 07/2016

NOTES:

1. All linear dimensions are in millimeters. Dimensions in parenthesis are for reference only. Dimensioning and tolerancing per ASME Y14.5M.
2. This drawing is subject to change without notice.
3. This dimension does not include mold flash, protrusions, or gate burrs. Mold flash, protrusions, or gate burrs shall not exceed 0.15 mm, per side.
4. This dimension does not include interlead flash. Interlead flash shall not exceed 0.25 mm, per side.
5. Reference JEDEC registration MS-013.

EXAMPLE BOARD LAYOUT

DW0016B

SOIC - 2.65 mm max height

SOIC



LAND PATTERN EXAMPLE
SCALE:4X

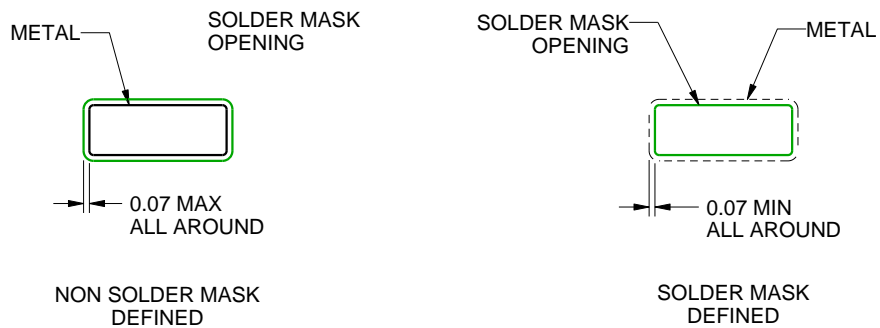

SOLDER MASK DETAILS

4221009/B 07/2016

NOTES: (continued)

- 6. Publication IPC-7351 may have alternate designs.
- 7. Solder mask tolerances between and around signal pads can vary based on board fabrication site.

EXAMPLE STENCIL DESIGN

DW0016B

SOIC - 2.65 mm max height

SOIC

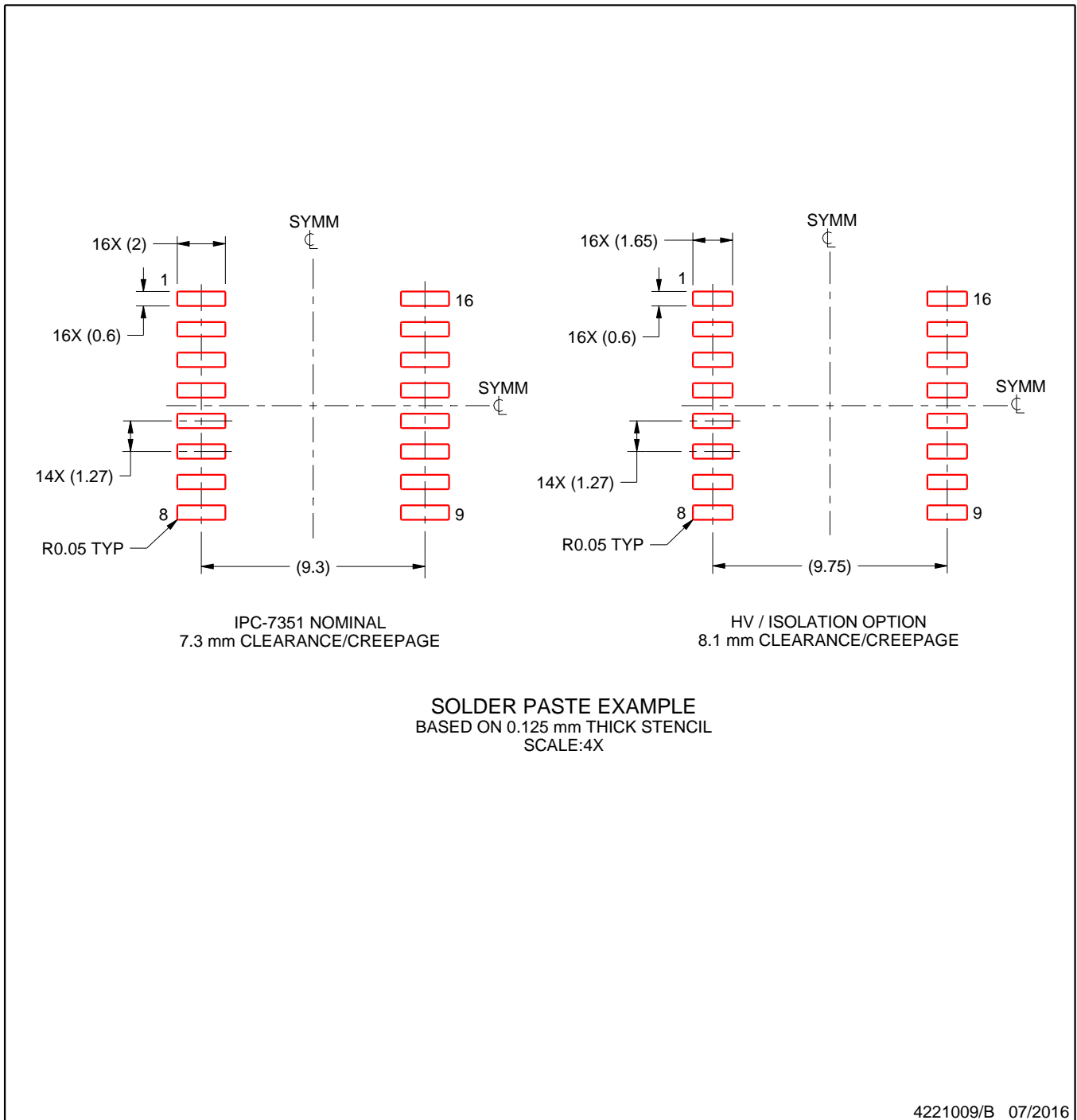

NOTES: (continued)

8. Laser cutting apertures with trapezoidal walls and rounded corners may offer better paste release. IPC-7525 may have alternate design recommendations.
9. Board assembly site may have different recommendations for stencil design.

重要なお知らせと免責事項

TI は、技術データと信頼性データ (データシートを含みます)、設計リソース (リファレンス デザインを含みます)、アプリケーションや設計に関する各種アドバイス、Web ツール、安全性情報、その他のリソースを、欠陥が存在する可能性のある「現状のまま」提供しており、商品性および特定目的に対する適合性の黙示保証、第三者の知的財産権の非侵害保証を含むいかなる保証も、明示的または黙示的にかかわらず拒否します。

これらのリソースは、TI 製品を使用する設計の経験を積んだ開発者への提供を意図したものです。(1) お客様のアプリケーションに適した TI 製品の選定、(2) お客様のアプリケーションの設計、検証、試験、(3) お客様のアプリケーションに該当する各種規格や、その他のあらゆる安全性、セキュリティ、規制、または他の要件への確実な適合に関する責任を、お客様のみが単独で負うものとし、

上記の各種リソースは、予告なく変更される可能性があります。これらのリソースは、リソースで説明されている TI 製品を使用するアプリケーションの開発の目的でのみ、TI はその使用をお客様に許諾します。これらのリソースに関して、他の目的で複製することや掲載することは禁止されています。TI や第三者の知的財産権のライセンスが付与されている訳ではありません。お客様は、これらのリソースを自身で使用した結果発生するあらゆる申し立て、損害、費用、損失、責任について、TI およびその代理人を完全に補償するものとし、TI は一切の責任を拒否します。

TI の製品は、[TI の販売条件](#)、[TI の総合的な品質ガイドライン](#)、[ti.com](#) または TI 製品などに関連して提供される他の適用条件に従い提供されます。TI がこれらのリソースを提供することは、適用される TI の保証または他の保証の放棄の拡大や変更を意味するものではありません。TI がカスタム、またはカスタマー仕様として明示的に指定していない限り、TI の製品は標準的なカタログに掲載される汎用機器です。

お客様がいかなる追加条項または代替条項を提案する場合も、TI はそれらに異議を唱え、拒否します。

Copyright © 2026, Texas Instruments Incorporated

最終更新日 : 2025 年 10 月