

INA253-Q1 PWM 除去機能および内蔵シャント抵抗を備える、AEC-Q100 認定済みの 80V、双方向、高精度電流センス・アンプ

1 特長

- 車載アプリケーション用に AEC-Q100 認定済み:
 - 温度グレード 1: $-40^{\circ}\text{C} \sim +125^{\circ}\text{C}$, T_A
- 機能安全対応
 - 機能安全システムの設計に役立つ資料を利用可能
- 高精度のシャント抵抗を内蔵
 - シャント抵抗: $2\text{m}\Omega$
 - シャント・インダクタンス: 3nH
 - シャント抵抗の公差: 0.1% (最大値)
 - $-40^{\circ}\text{C} \sim +85^{\circ}\text{C}$ で $\pm 15\text{A}$ の連続電流
 - $0^{\circ}\text{C} \sim 125^{\circ}\text{C}$ の動作温度範囲 $10\text{ppm}/^{\circ}\text{C}$
- 広い帯域幅: 350kHz
- 強化された PWM 除去
- 非常に優れた CMRR
 - 120dB を超える DC CMRR
 - 50kHz において 90dB の AC CMRR
- 精度:
 - ゲイン:
 - ゲイン誤差: 0.4% (最大値)
 - ゲイン・ドリフト: $45\text{ppm}/^{\circ}\text{C}$ (最大値)
 - オフセット:
 - オフセット電流: $\pm 15\text{mA}$ (最大値)
 - オフセットのドリフト: $125\mu\text{A}/^{\circ}\text{C}$ (最大値)
- 広い同相電圧範囲: $-4\text{V} \sim +80\text{V}$
- 利用可能なゲイン: $100\text{mV}/\text{A}$, $200\text{mV}/\text{A}$, $400\text{mV}/\text{A}$
- 静止電流: 2.4mA (最大値)

2 アプリケーション

- ディーゼル・エンジン
- ガソリン・エンジン
- バルブまたはモータ・アクチュエータ
- オートマチック・トランスミッション (AT)
- マニュアル・トランスミッション (MT)
- パワートレイン電流センサ

3 概要

INA253-Q1 は車載用の電圧出力、電流検出アンプで、 $2\text{m}\Omega$ のシャント抵抗が内蔵されています。INA253-Q1 は、電源電圧にかかわらず、 $-4\text{V} \sim +80\text{V}$ の広い同相電圧範囲で双方向の電流を監視します。3 つの固定ゲインを利用可能: $100\text{mV}/\text{A}$, $200\text{mV}/\text{A}$, $400\text{mV}/\text{A}$ 高精度の抵抗とゼロ・ドリフトのチョップ・アンプを内蔵しているため、較正と等価の測定精度、 $15\text{ppm}/^{\circ}\text{C}$ という非常に低い温度ドリフト係数、センシング抵抗に最適化されたケルビン・レイアウトが実現されています。

INA253-Q1 の設計には強化された PWM 除去回路が組み込まれており、大きな (dv/dt) 信号を抑制し、リアルタイムで連続的な電流測定が可能です。この測定機能は、モータ・ドライブ・アプリケーションにおけるインラインの電流測定や、ソレノイド・バルブ制御アプリケーションなどに不可欠です。

このデバイスは $2.7\text{V} \sim 5.5\text{V}$ の単電源で動作し、消費電流は最大 3mA です。どのゲインのバージョンも、 $-40^{\circ}\text{C} \sim +125^{\circ}\text{C}$ の温度範囲で動作が規定され、20 ピンの TSSOP パッケージで供給されます。

製品情報 (1)

部品番号	パッケージ	本体サイズ (公称)
INA253-Q1	TSSOP (20)	6.50mm × 4.40mm

- (1) 利用可能なパッケージについては、データシートの末尾にあるパッケージ・オプションについての付録を参照してください。

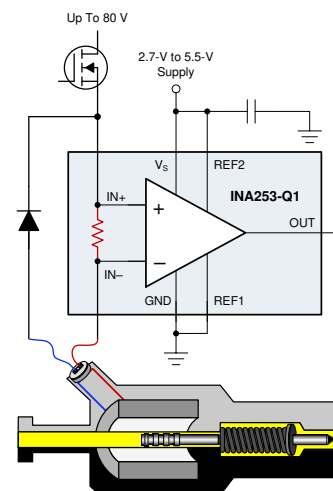

代表的なアプリケーション



Table of Contents

1 特長	1	8 Application and Implementation	19
2 アプリケーション	1	8.1 Application Information.....	19
3 概要	1	8.2 Typical Applications.....	21
4 Revision History	2	9 Power Supply Recommendations	25
5 Pin Configuration and Functions	3	10 Layout	26
6 Specifications	4	10.1 Layout Guidelines.....	26
6.1 Absolute Maximum Ratings.....	4	10.2 Layout Example.....	26
6.2 ESD Ratings.....	4	11 Device and Documentation Support	27
6.3 Recommended Operating Conditions.....	4	11.1 Device Support.....	27
6.4 Thermal Information.....	4	11.2 Related Documentation.....	27
6.5 Electrical Characteristics.....	5	11.3 ドキュメントの更新通知を受け取る方法.....	27
6.6 Typical Characteristics.....	7	11.4 サポート・リソース.....	27
7 Detailed Description	12	11.5 Trademarks.....	27
7.1 Overview.....	12	11.6 静電気放電に関する注意事項.....	27
7.2 Functional Block Diagram.....	12	11.7 用語集.....	27
7.3 Feature Description.....	12	12 Mechanical, Packaging, and Orderable Information	27
7.4 Device Functional Modes.....	16		

4 Revision History

Changes from Revision * (July 2019) to Revision A (January 2021)	Page
• ドキュメント全体にわたって表、図、相互参照の採番方法を更新.....	1
• 「機能安全対応」の箇条書き項目を追加.....	1

Device Comparison Table

PRODUCT	GAIN (mV/A)
INA253A1-Q1	100
INA253A2-Q1	200
INA253A3-Q1	400

5 Pin Configuration and Functions



图 5-1. PW Package 20-Pin TSSOP Top View

表 5-1. Pin Functions

PIN		I/O	DESCRIPTION
NO.	NAME		
1	IS-	Analog input	Connect to load
2	IS-	Analog input	Connect to load
3	IS-	Analog input	Connect to load
4	SH-	Analog output	Kelvin connection to internal shunt. Connect to IN- if no filtering is needed
5	IN-	Analog input	Voltage input from load side of shunt resistor
6	GND	—	Ground
7	DNC1	—	Do not connect this pin to any potential; leave this pin floating.
8	NC	—	No connect
9	VS	Analog	Power supply, 2.7 V to 5.5 V
10	REF2	Analog input	Reference voltage 2, 0 V to VS
11	REF1	Analog input	Reference voltage 1, 0 V to VS
12	NC	—	No connect
13	OUT	Analog	Output voltage
14	DNC2	—	Do not connect this pin to any potential; leave this pin floating.
15	NC	Analog	Reserved; connect this pin to ground
16	IN+	Analog input	Voltage input from supply side of shunt resistor
17	SH+	Analog output	Kelvin connection to internal shunt. Connect to IN+ if no filtering is needed
18	IS+	Analog input	Connect to supply
19	IS+	Analog input	Connect to supply
20	IS+	Analog input	Connect to supply

6 Specifications

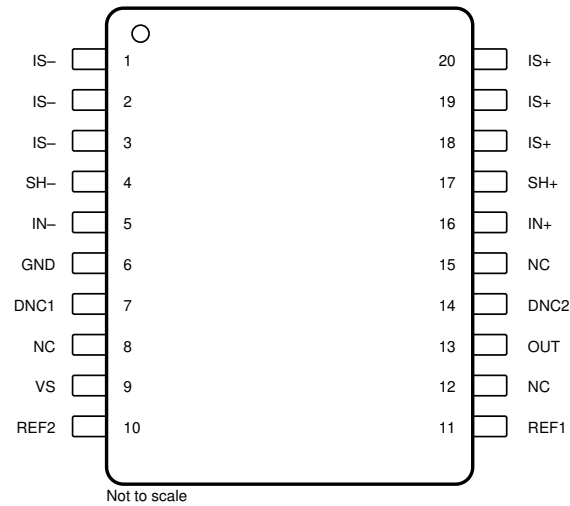
6.1 Absolute Maximum Ratings

over operating free-air temperature range (unless otherwise noted)⁽¹⁾

		MIN	MAX	UNIT
Supply voltage			6	V
Shunt input current (I _{SENSE})	Continuous		±15	A
Analog inputs (IS+, IS-)	Common-mode	GND – 6	90	V
Analog inputs (V _{IN+} , V _{IN-})	Differential (V _{IN+}) – (V _{IN-})	–80	80	V
	Common-mode	GND – 6	90	
Analog inputs (REF1, REF2, NC)		GND – 0.3	V _S + 0.3	V
Analog outputs (SH+, SH-)	Common-mode	GND – 6	90	V
Analog output (OUT)		GND – 0.3	V _S + 0.3	V
Temperature	Operating, T _A	–55	150	°C
	Junction, T _J		150	
	Storage, T _{stg}	–65	150	

- (1) Stresses beyond those listed under *Absolute Maximum Ratings* may cause permanent damage to the device. These are stress ratings only, which do not imply functional operation of the device at these or any other conditions beyond those indicated under *Recommended Operating Conditions*. Exposure to absolute-maximum-rated conditions for extended periods may affect device reliability.

6.2 ESD Ratings

			VALUE	UNIT
V _(ESD)	Electrostatic discharge	Human body model (HBM), per AEC Q100-002 ⁽¹⁾ HBM ESD Classification Level 2	±3000	V
		Charged device model (CDM), per AEC Q100-011 CDM ESD Classification Level C6	±1000	

- (1) AEC Q100-002 indicates that HBM stressing shall be in accordance with the ANSI/ESDA/JEDEC JS-001 specification.

6.3 Recommended Operating Conditions

over operating free-air temperature range (unless otherwise noted)

		MIN	NOM	MAX	UNIT
V _{CM}	Common-mode input voltage	–4		80	V
V _S	Operating supply voltage	2.7		5.5	V
T _A	Operating free-air temperature	–40		125	°C

6.4 Thermal Information

THERMAL METRIC ⁽¹⁾		INA253-Q1	UNIT
		PW (TSSOP)	
		20 PINS	
R _{θJA}	Junction-to-ambient thermal resistance	110.6	°C/W
R _{θJC(top)}	Junction-to-case (top) thermal resistance	54.1	°C/W
R _{θJB}	Junction-to-board thermal resistance	87.5	°C/W
ψ _{JT}	Junction-to-top characterization parameter	114.1	°C/W
ψ _{JB}	Junction-to-board characterization parameter	87.5	°C/W

- (1) For more information about traditional and new thermal metrics, see the [Semiconductor and IC Package Thermal Metrics](#) application report.

6.5 Electrical Characteristics

at $T_A = 25\text{ }^\circ\text{C}$, $V_S = 5\text{ V}$, $I_{\text{SENSE}} = I_{\text{S}+} = 0\text{ A}$, $V_{\text{CM}} = 12\text{ V}$, and $V_{\text{REF1}} = V_{\text{REF2}} = V_S / 2$ (unless otherwise noted)

PARAMETER		TEST CONDITIONS	MIN	TYP	MAX	UNIT	
INPUT							
V_{CM}	Common-mode input range	$V_{\text{IN+}} = -4\text{ V to }+80\text{ V}$, $I_{\text{SENSE}} = 0\text{ A}$, $T_A = -40\text{ }^\circ\text{C to }+125\text{ }^\circ\text{C}$	-4		80	V	
CMR	Common-mode rejection	$V_{\text{IN+}} = -4\text{ V to }+80\text{ V}$, $I_{\text{SENSE}} = 0\text{ A}$, $T_A = -40\text{ }^\circ\text{C to }+125\text{ }^\circ\text{C}$		± 125	± 500	$\mu\text{A/V}$	
		$f = 50\text{ kHz}$		± 13		mA/V	
I_{OS}	Offset current, input-referred	$I_{\text{SENSE}} = 0\text{ A}$		± 2.5	± 15	mA	
dI_{OS}/dT	Offset current drift	$I_{\text{SENSE}} = 0\text{ A}$, $T_A = -40\text{ }^\circ\text{C to }+125\text{ }^\circ\text{C}$		25	125	$\mu\text{A}/^\circ\text{C}$	
PSRR	Power-supply rejection ratio	$V_S = 2.7\text{ V to }5.5\text{ V}$, $I_{\text{SENSE}} = 0\text{ A}$		± 0.5	± 5	mA/V	
I_B	Input bias current	$I_{\text{B+}}$, $I_{\text{B-}}$, $I_{\text{SENSE}} = 0\text{ A}$		90		μA	
	Reference input range		0		V_S	V	
SHUNT RESISTOR							
R_{SHUNT}	Shunt resistance (SH+ to SH-)	Equivalent resistance when used with onboard amplifier	1.998	2	2.002	m Ω	
		Used as stand-alone resistor ⁽¹⁾	1.9	2	2.1		
	Package resistance	IS+ to IS-		4.5		m Ω	
	Package inductance	IS+ to IS-		3		nH	
	Resistor temperature coefficient	$T_A = -40\text{ }^\circ\text{C to }+125\text{ }^\circ\text{C}$		15		ppm/ $^\circ\text{C}$	
		$T_A = -40\text{ }^\circ\text{C to }0\text{ }^\circ\text{C}$		50			
		$T_A = 0\text{ }^\circ\text{C to }125\text{ }^\circ\text{C}$		10			
I_{SENSE}	Maximum continuous current ⁽²⁾	$T_A = -40\text{ }^\circ\text{C to }+85\text{ }^\circ\text{C}$			± 15	A	
	Shunt short time overload	$I_{\text{SENSE}} = 30\text{ A}$ for 5 seconds		$\pm 0.05\%$			
	Shunt thermal shock	$-65\text{ }^\circ\text{C to }+150\text{ }^\circ\text{C}$, 500 cycles		$\pm 0.1\%$			
	Shunt resistance to solder heat	260 $^\circ\text{C}$ solder, 10 seconds		$\pm 0.1\%$			
	Shunt high temperature exposure	1000 hours, $T_A = 150\text{ }^\circ\text{C}$		$\pm 0.15\%$			
	Shunt cold temperature storage	24 hours, $T_A = -65\text{ }^\circ\text{C}$		$\pm 0.025\%$			
	OUTPUT						
	G	Gain	INA253A1		100		mV/A
INA253A2				200			
INA253A3				400			
	System gain error ⁽³⁾	$\text{GND} + 50\text{ mV} \leq V_{\text{OUT}} \leq V_S - 200\text{ mV}$, $T_A = 25\text{ }^\circ\text{C}$		$\pm 0.05\%$	$\pm 0.4\%$		
		$T_A = -40\text{ }^\circ\text{C to }+125\text{ }^\circ\text{C}$			± 45	ppm/ $^\circ\text{C}$	
	Nonlinearity error	$\text{GND} + 10\text{ mV} \leq V_{\text{OUT}} \leq V_S - 200\text{ mV}$		$\pm 0.01\%$			
	Reference divider accuracy	$V_{\text{OUT}} = (V_{\text{REF1}} - V_{\text{REF2}}) / 2$ at $I_{\text{SENSE}} = 0\text{ A}$, $T_A = -40\text{ }^\circ\text{C to }+125\text{ }^\circ\text{C}$		0.02%	0.1%		
RVRR	Reference voltage rejection ratio (input-referred)	INA253A2		2.5		mV/V	
		INA253A1, INA253A3		1			
	Maximum capacitive load	No sustained oscillation		1		nF	
VOLTAGE OUTPUT							
	Swing to V_S power-supply rail	$R_L = 10\text{ k}\Omega$ to GND, $T_A = -40\text{ }^\circ\text{C to }+125\text{ }^\circ\text{C}$		$V_S - 0.05$	$V_S - 0.2$	V	
	Swing to GND	$R_L = 10\text{ k}\Omega$ to GND, $I_{\text{SENSE}} = 0\text{ A}$, $V_{\text{REF1}} = V_{\text{REF2}} = 0\text{ V}$, $T_A = -40\text{ }^\circ\text{C to }+125\text{ }^\circ\text{C}$		$V_{\text{GND}} + 1$	$V_{\text{GND}} + 10$	mV	

INA253-Q1

JAJSH07A – JULY 2019 – REVISED JANUARY 2021

 at $T_A = 25\text{ }^\circ\text{C}$, $V_S = 5\text{ V}$, $I_{\text{SENSE}} = I_{\text{S+}} = 0\text{ A}$, $V_{\text{CM}} = 12\text{ V}$, and $V_{\text{REF1}} = V_{\text{REF2}} = V_S / 2$ (unless otherwise noted)

PARAMETER		TEST CONDITIONS	MIN	TYP	MAX	UNIT
FREQUENCY RESPONSE						
BW	Bandwidth ⁽⁴⁾	All gains, –3-dB bandwidth		350		kHz
		All gains, 2% THD+N ⁽⁴⁾		100		
	Output settling time	Settles to 0.5% of final value		10		μs
SR	Slew rate			2.4		V/μs
NOISE (Input Referred)						
	Voltage noise density			40		nV/√Hz
POWER SUPPLY						
I _Q	Quiescent current	$I_{\text{SENSE}} = 0\text{ A}$		1.8	2.4	mA
		$T_A = -40\text{ }^\circ\text{C to } +125\text{ }^\circ\text{C}$			2.6	

- (1) The internal shunt resistor is intended to be used with the internal amplifier and is not intended to be used as a stand-alone resistor. See the [Integrated Shunt Resistor](#) section for more information.
- (2) See [Maximum Continuous Current](#) for additional information on the current derating and review [layout](#) section recommendations to improve the current handling capability of the device at higher temperatures.
- (3) System gain error includes amplifier gain error and the integrated sense resistor tolerance. System gain error does not include the stress related characteristics of the integrated sense resistor. These characteristics are described in the [Shunt Resistor](#) section of the [Electrical Characteristics](#) table.
- (4) See [Bandwidth](#) section for more details.

6.6 Typical Characteristics

at $T_A = 25\text{ }^\circ\text{C}$, $V_S = 5\text{ V}$, $V_{IN+} = 12\text{ V}$, and $V_{REF} = V_S / 2$ (unless otherwise noted)

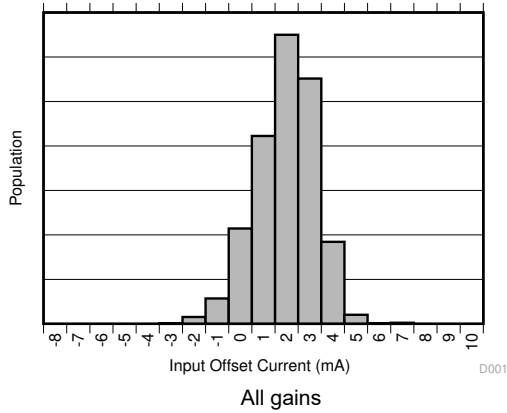

FIG 6-1. Input Offset Voltage Production Distribution

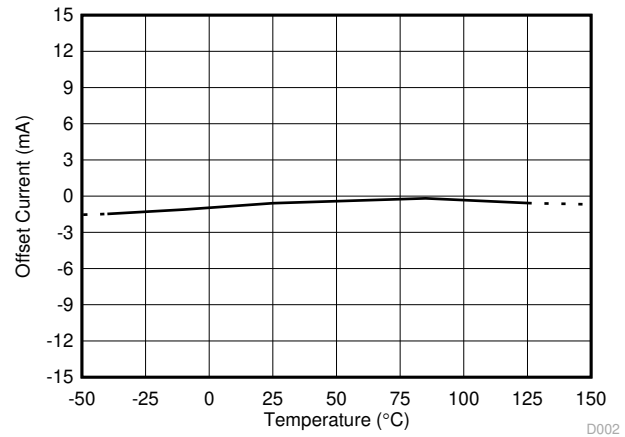

FIG 6-2. Input Offset Current vs Temperature

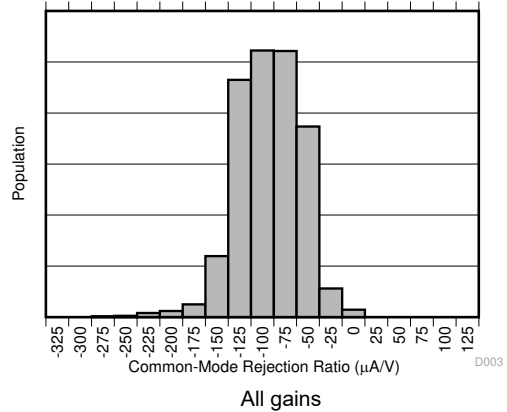

FIG 6-3. Common-Mode Rejection Production Distribution

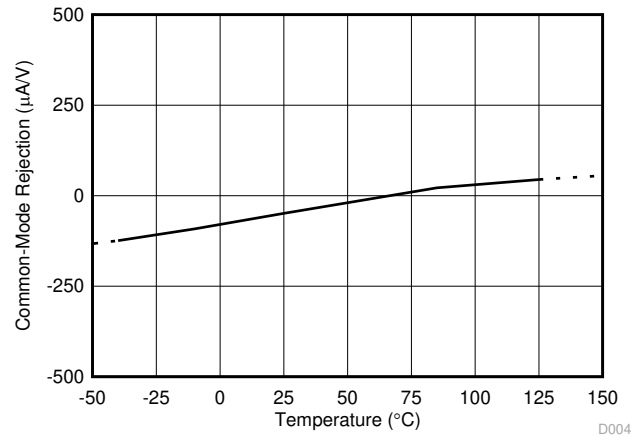

FIG 6-4. Common-Mode Rejection Ratio vs Temperature

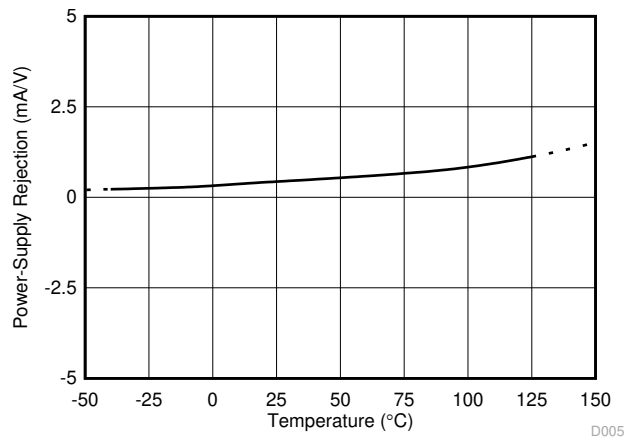

FIG 6-5. Power-Supply Rejection Ratio vs Temperature

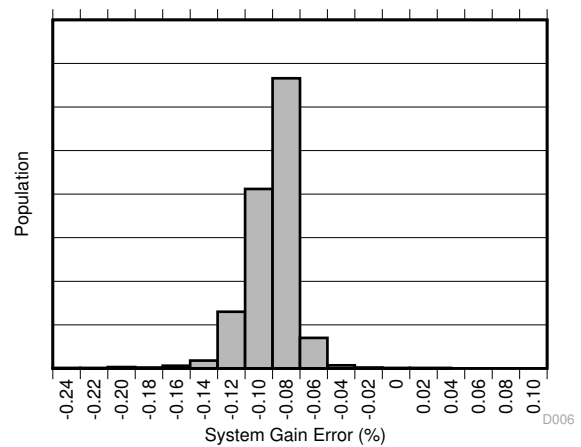
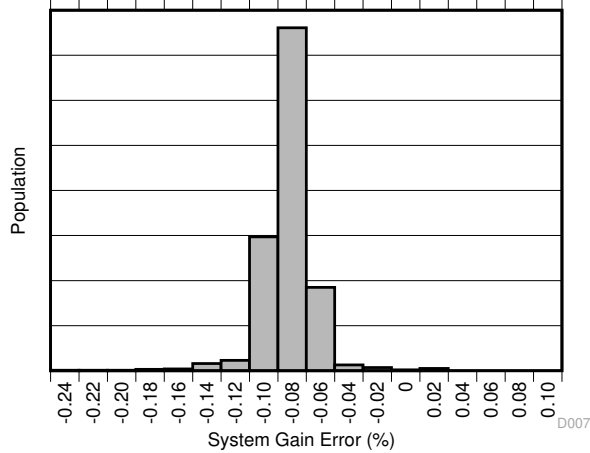
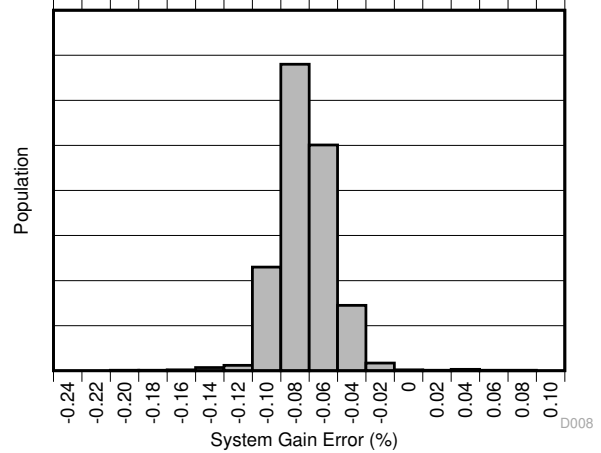

FIG 6-6. Gain Error Production Distribution (INA253A1-Q1)



6-7. Gain Error Production Distribution (INA253A2-Q1)



6-8. Gain Error Production Distribution (INA253A3-Q1)

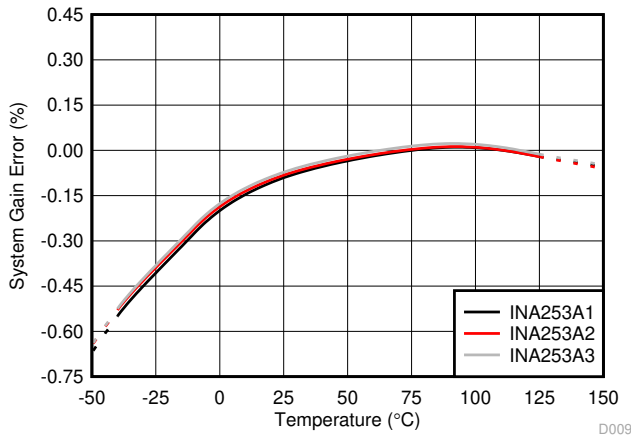

6-9. System Gain Error vs Temperature

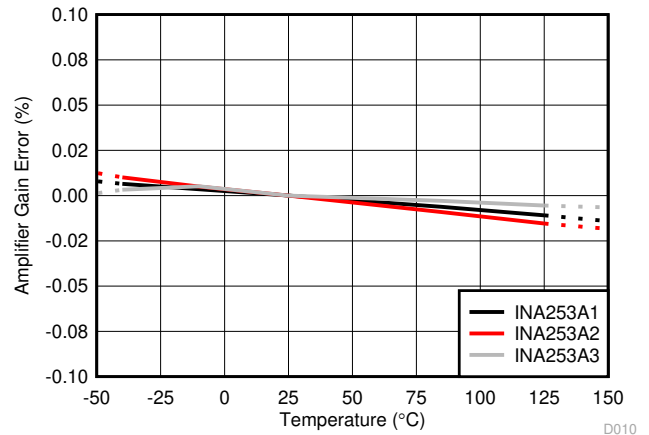

6-10. Amplifier Gain Error vs Temperature

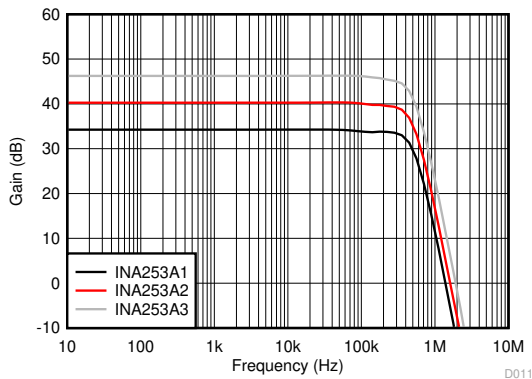

6-11. Amplifier Gain Error vs Frequency

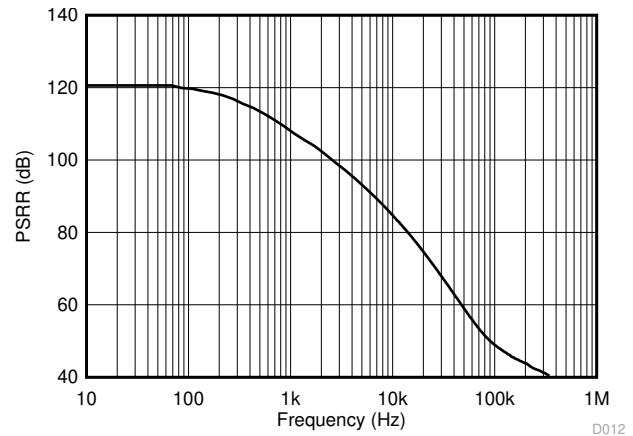

6-12. Power-Supply Rejection Ratio vs Frequency

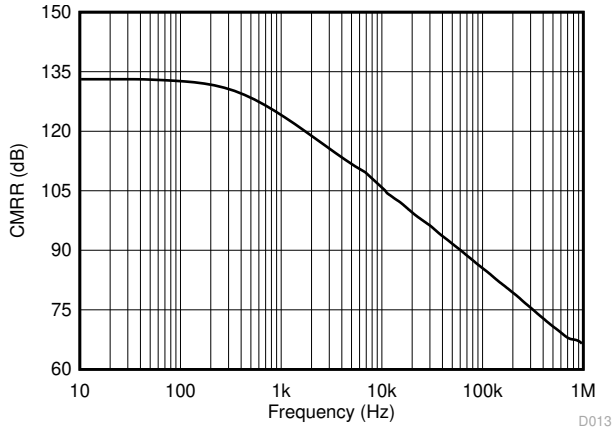

6-13. Common-Mode Rejection Ratio vs Frequency

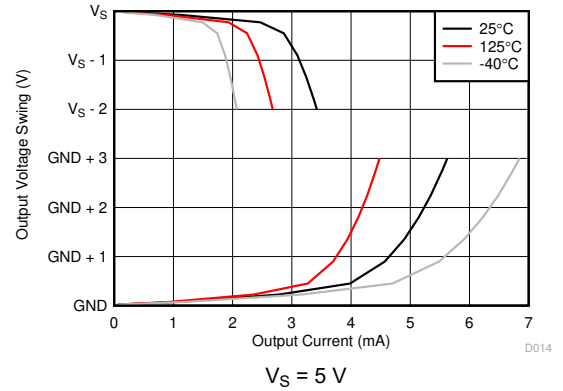

6-14. Output Voltage Swing vs Output Current

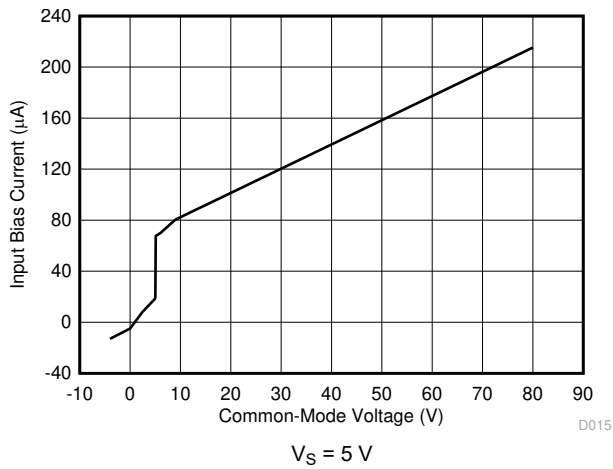

6-15. Input Bias Current vs Common-Mode Voltage

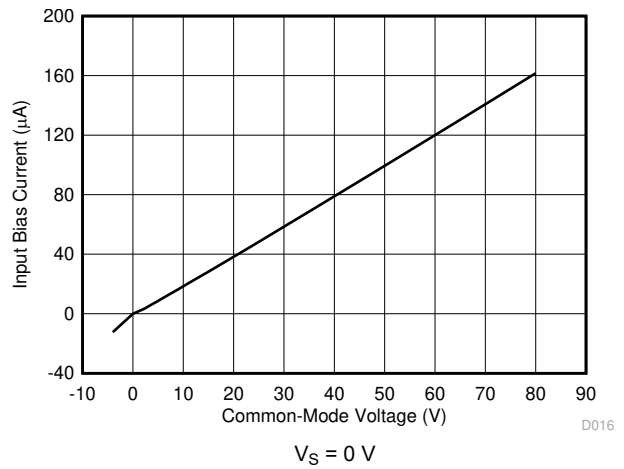

6-16. Input Bias Current vs Common-Mode Voltage

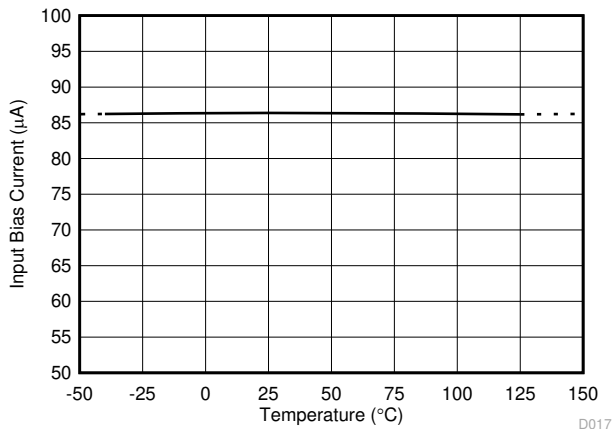

6-17. Input Bias Current vs Temperature

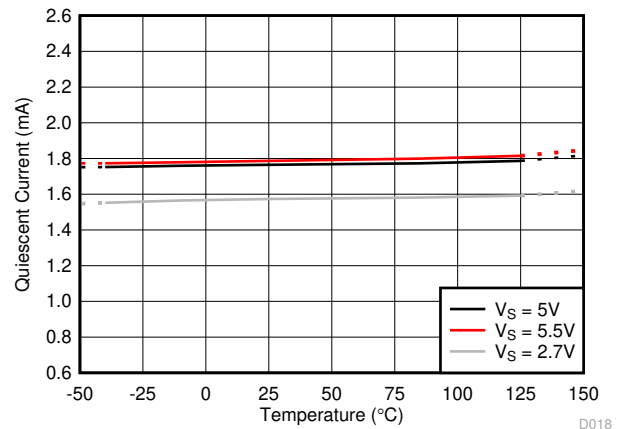

6-18. Quiescent Current vs Temperature

INA253-Q1

JAJSHO7A – JULY 2019 – REVISED JANUARY 2021

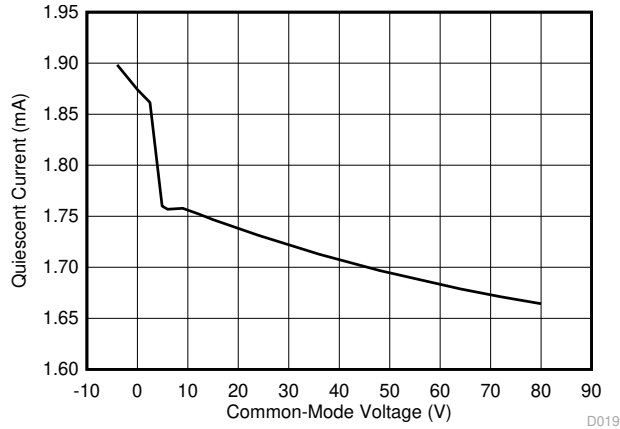

6-19. Quiescent Current vs Common-mode Voltage

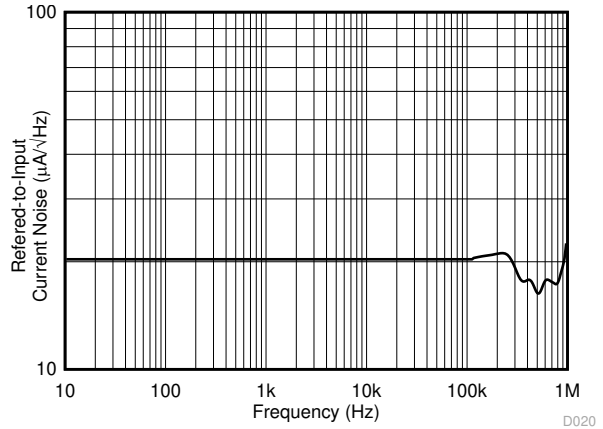

6-20. INA253A1-Q1 Input-Referred Voltage Noise vs Frequency

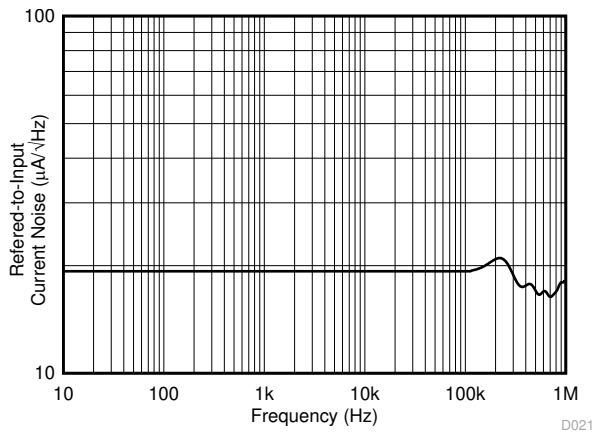

6-21. INA253A2-Q1 Input-Referred Voltage Noise vs Frequency

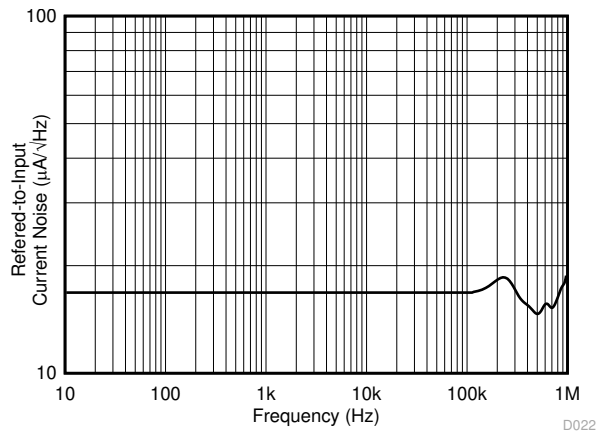

6-22. INA253A3-Q1 Input-Referred Voltage Noise vs Frequency

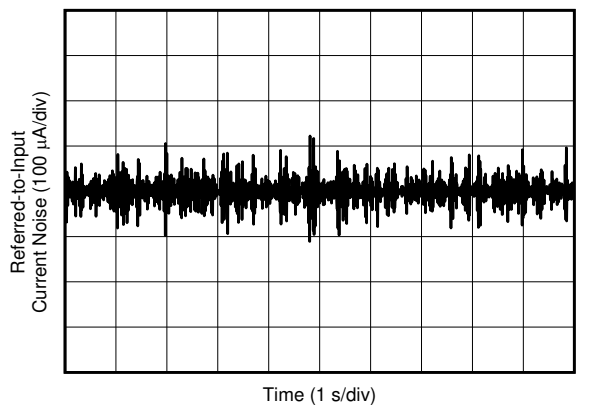

6-23. 0.1-Hz to 10-Hz Voltage Noise (Referred-to-Input)

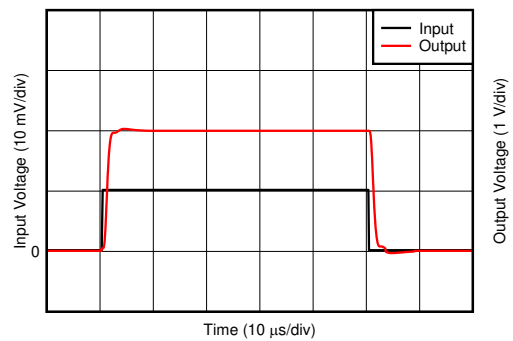

$V_{REF1} = V_{REF2} = 0$ V, 10-mV_{PP} input step

6-24. Amplifier Step Response

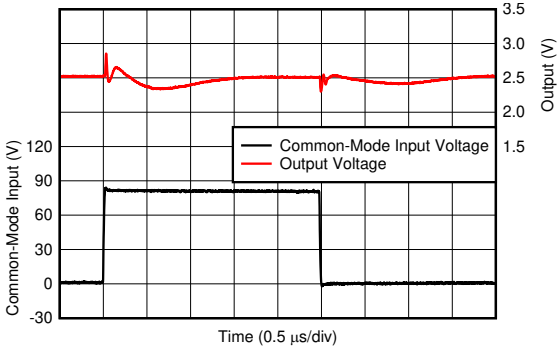

$V_{REF1} = V_{REF2} = 0\text{ V}$

6-25. Common-Mode Transient Response

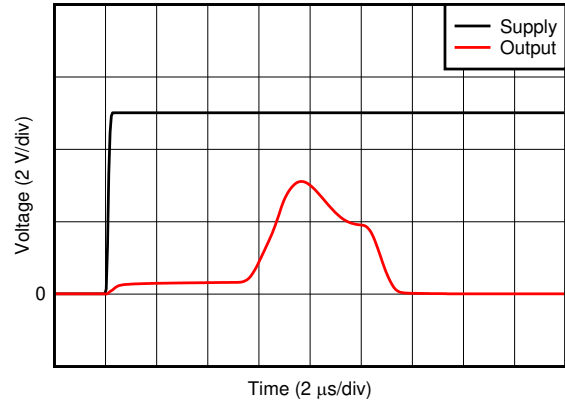

6-26. Start-Up Response

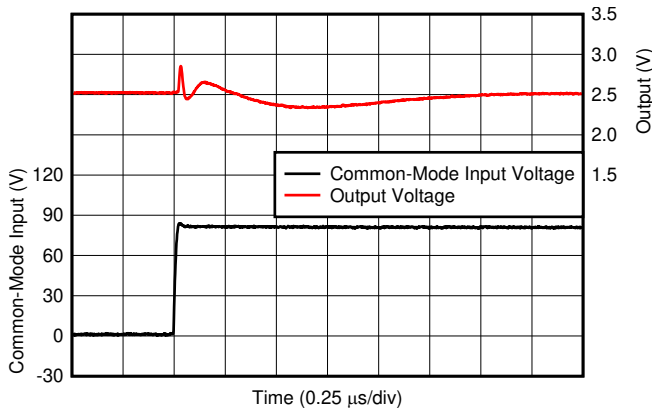

Rising Edge

6-27. Common-Mode Voltage Transient Response

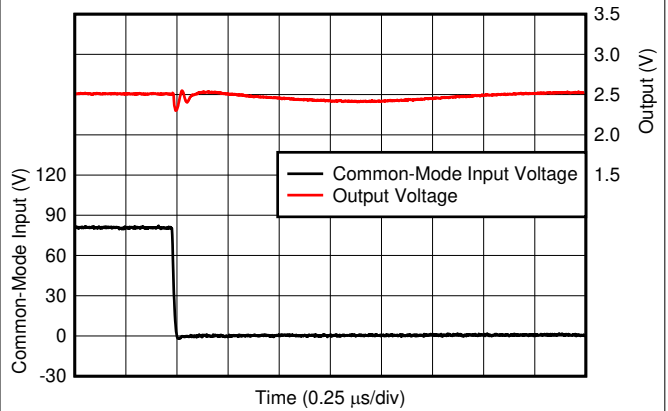

Falling Edge

6-28. Common-Mode Voltage Transient Response

7 Detailed Description

7.1 Overview

The INA253-Q1 features a precision, 2-m Ω current-sensing resistor and supports common mode voltages up to 80 V. The internal amplifier features a precision zero-drift topology with excellent common-mode rejection ratio (CMRR). The internal amplifier also features an enhanced pulse-width modulation (PWM) rejection current-sensing amplifier integrated into a single package. High-precision measurements are enabled by matching the shunt resistor value and the current-sensing amplifier gain, thus providing a highly-accurate, system-calibrated method for measuring current. Enhanced PWM rejection reduces the effect of common-mode transients on the output signal that are associated with PWM signals. Multiple gain versions are available to allow for the optimization of the desired full-scale output voltage based on the target current range expected in the application.

7.2 Functional Block Diagram

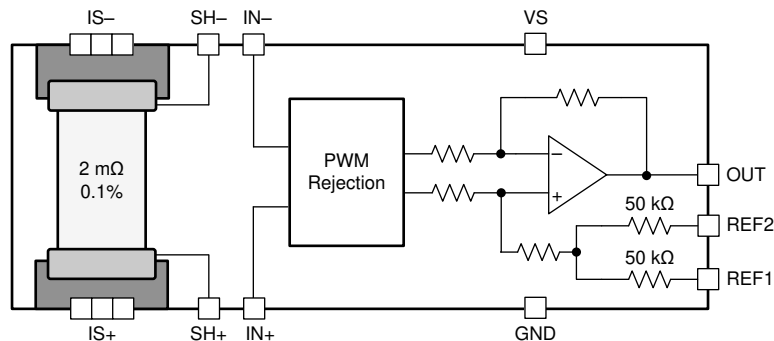

7.3 Feature Description

7.3.1 Integrated Shunt Resistor

The INA253-Q1 features a precise, low-drift, current-sensing resistor that provides accurate measurements over the entire specified temperature range of $-40\text{ }^{\circ}\text{C}$ to $+125\text{ }^{\circ}\text{C}$. The integrated current-sensing resistor provides measurement stability over temperature, and simplifies printed circuit board (PCB) layout and board constraint difficulties common in high-precision measurements.

The onboard current-sensing resistor is designed as a 4-wire (or Kelvin) connected resistor that enables accurate measurements through a force-sense connection. Connecting the amplifier inputs pins (VIN $-$ and VIN $+$) to the sense pins of the shunt resistor (SH $-$ and SH $+$) eliminates many of the parasitic impedances commonly found in typical very-low sensing-resistor level measurements. Although the sense connection of the current-sensing resistor can be accessed through the SH $+$ and SH $-$ pins, this resistor is not intended to be used as a stand-alone component. The INA253-Q1 is system-calibrated to make sure that the current-sensing resistor and current-sensing amplifier are both precisely matched to one another. Use of the shunt resistor without the onboard amplifier results in a current-sensing resistor tolerance of approximately 5%. To achieve the optimized system gain specification, the onboard sensing resistor must be used with the internal current-sensing amplifier.

The INA253-Q1 has approximately 4.5 m Ω of package resistance. Of this total package resistance, 2 m Ω is a precisely-controlled resistance from the Kelvin-connected current-sensing resistor used by the amplifier. The power dissipation requirements of the system and package are based on the total 4.5-m Ω package resistance between the IS $+$ and IS $-$ pins. The heat dissipated across the package when current flows through the device ultimately determines the maximum current that can be safely handled by the package. The current consumption of the silicon is relatively low, leaving the total package resistance to carry the high load current as the primary contributor to the total power dissipation of the package. The maximum safe-operating current level is set to make sure that the heat dissipated across the package is limited so that no damage occurs to the resistor or the package, or that the internal junction temperature of the silicon does not exceed a $150\text{ }^{\circ}\text{C}$ limit.

External factors, such as ambient temperature, external air flow, and PCB layout, contribute to how effectively the device dissipates heat. The internal heat is developed as a result of the current flowing through the total

package resistance of 4.5 mΩ. Under the conditions of no air flow, a maximum ambient temperature of 85 °C, and 1-oz. copper input power planes, the INA253-Q1 accommodates continuous current levels up to 15 A. [Figure 7-1](#) shows that the current-handling capability is derated at temperatures greater than the 85 °C level, with safe operation up to 10 A at a 125 °C ambient temperature. With air flow and larger 2-oz. copper input power planes, the INA253-Q1 safely accommodates continuous current levels up to 15 A across the entire –40 °C to +125 °C temperature range.

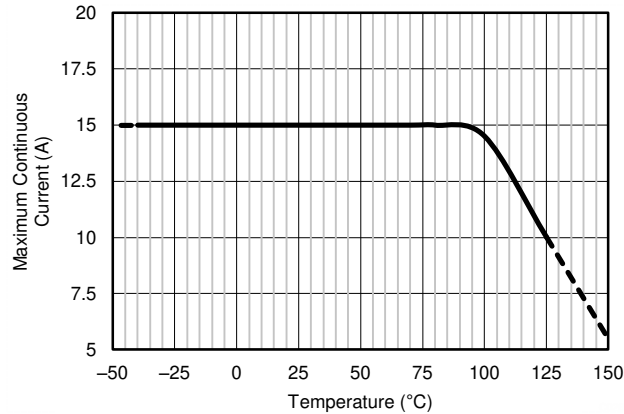

Figure 7-1. Maximum Continuous Current vs Temperature

7.3.2 Short-Circuit Duration

The INA253-Q1 features a physical shunt resistance that is able to withstand current levels higher than the continuous handling limit of 15 A without sustaining damage to the current-sensing resistor or the current-sensing amplifier, if the excursions are brief. [Figure 7-2](#) shows the short-circuit duration curve for the INA253-Q1.

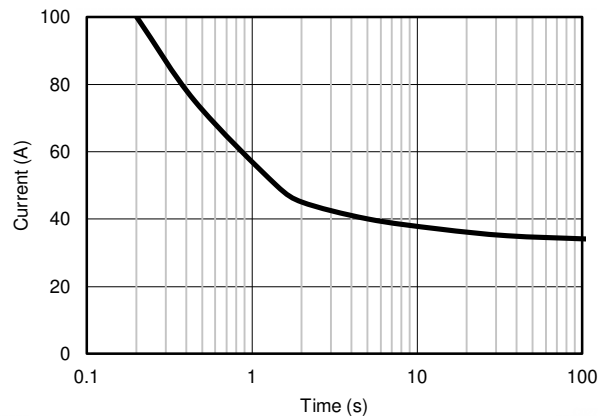

Figure 7-2. Short-Circuit Duration

7.3.3 Temperature Stability

System calibration is common for many industrial applications in order to eliminate initial component and system-level errors that can be present. A system-level calibration reduces the initial accuracy requirement for many of the individual components because the errors associated with these components are effectively eliminated through the calibration procedure. This calibration enables precise measurements at the temperature in which the system is calibrated. As the system temperature changes because of external ambient changes or self heating, measurement errors are reintroduced. Without accurate temperature compensation used in addition to the initial adjustment, the calibration procedure is not effective. The user must account for temperature-induced changes. One of the primary benefits of the low temperature coefficient of the INA253-Q1 (including both the integrated current-sensing resistor and current-sensing amplifier) is that the device measurement remains accurate, even when the temperature changes throughout the specified temperature range of the device.

Figure 7-3 shows the drift performance for the integrated current-sensing resistor. Use Figure 7-3 to determine the typical variance in the shunt resistor value at various temperatures. As with any resistive element, the tolerance of the component varies when exposed to different temperature conditions. For the current-sensing resistor integrated in the INA253-Q1, the resistor does vary slightly more when operated in temperatures ranging from $-40\text{ }^{\circ}\text{C}$ to $0\text{ }^{\circ}\text{C}$ than when operated from $0\text{ }^{\circ}\text{C}$ to $125\text{ }^{\circ}\text{C}$. Even in the $-40\text{ }^{\circ}\text{C}$ to $0\text{ }^{\circ}\text{C}$ temperature range, the drift is still low at $25\text{ ppm}/^{\circ}\text{C}$.

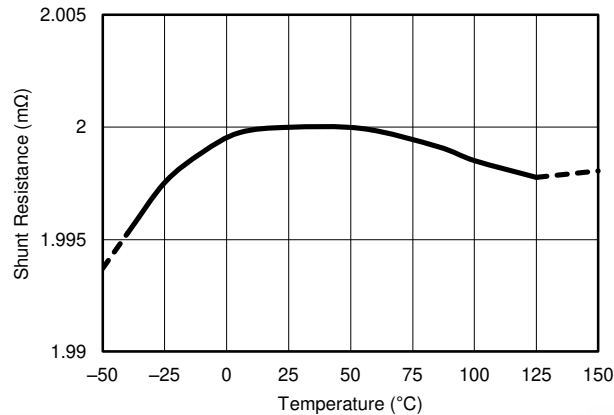

Figure 7-3. Sensing Resistor vs Temperature

An additional aspect to consider is that when current flows through the current-sensing resistor, power is dissipated across this component. This dissipated power results in an increase in the internal temperature of the package, including the integrated sensing resistor. This resistor self-heating effect results in an increase of the resistor temperature helping to move the component out of the colder, wider drift temperature region.

7.3.4 Enhanced PWM Rejection Operation

The enhanced PWM rejection feature of the INA253-Q1 provides increased attenuation of large common-mode $\Delta V/\Delta t$ transients. Large $\Delta V/\Delta t$ common-mode transients associated with PWM signals are employed in applications such as motor or solenoid drive and switching power supplies. Traditionally, large $\Delta V/\Delta t$ common-mode transitions are handled strictly by increasing the amplifier signal bandwidth, which can increase chip size, complexity and ultimately cost. The INA253-Q1 is designed with high common-mode rejection techniques to reduce large $\Delta V/\Delta t$ transients before the system is disturbed as a result of these large signals. The high ac CMRR, in conjunction with signal bandwidth, allows the INA253-Q1 to provide minimal output transients and ringing compared with standard circuit approaches.

7.3.5 Input Signal Bandwidth

The INA253-Q1 input signal, which represents the current being measured, is accurately measured with minimal disturbance from large $\Delta V/\Delta t$ common-mode transients as previously described. For PWM signals typically associated with motors, solenoids, and other switching applications, the current being monitored varies at a significantly slower rate than the faster PWM frequency.

The INA253-Q1 bandwidth is defined by the -3 -dB bandwidth of the current-sense amplifier inside the device; see [セクション 6.5](#) for more information. The device bandwidth provides fast throughput and fast response required for the rapid detection and processing of overcurrent events. Without the higher bandwidth, protection circuitry may not have adequate response time, and damage may occur to the monitored application or circuit.

 [7-4](#) shows the performance profile of the device over frequency. Harmonic distortion increases at the upper end of the amplifier bandwidth with no adverse change in detection of overcurrent events. However, increased distortion at the highest frequencies must be considered when the measured current bandwidth begins to approach the INA253-Q1 bandwidth.

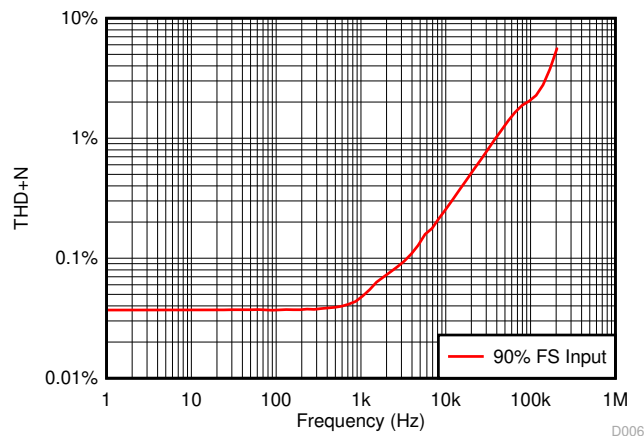

 **7-4. Amplifier Performance Over Frequency**

For applications requiring distortion sensitive signals, [7-4](#) provides information to show that there is an optimal frequency performance range for the amplifier. The full amplifier bandwidth is always available for fast overcurrent events at the same time that the lower-frequency signals are amplified at a low distortion level. The output signal accuracy is reduced for frequencies closer to the maximum bandwidth. Individual requirements determine the acceptable limits of distortion for high-frequency, current-sensing applications. Testing and evaluation in the end application or circuit are required to determine the acceptance criteria, and to validate the performance levels meet the system specifications.

7.4 Device Functional Modes

7.4.1 Adjusting the Output Midpoint With the Reference Pins

Figure 7-5 shows a test circuit for reference-divider accuracy. The INA253-Q1 output is configurable to allow for unidirectional or bidirectional operation.

注意

Do not connect the REF1 pin or the REF2 pin to any voltage source lower than GND or higher than V_S .

The output voltage is set by applying a voltage or voltages to the reference voltage inputs, REF1 and REF2. The reference inputs are connected to an internal gain network. There is no operational difference between the two reference pins.

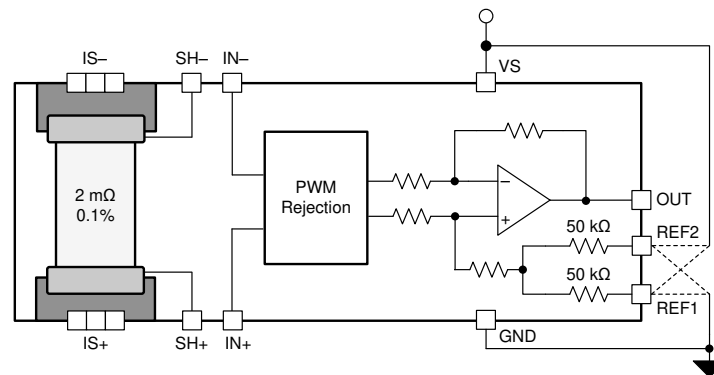

Figure 7-5. Adjusting the Output Midpoint

7.4.2 Reference Pin Connections for Unidirectional Current Measurements

Unidirectional operation allows current measurements through a resistive shunt in one direction. For unidirectional operation, connect the device reference pins together and then to the negative rail (see [セクション 7.4.3](#)). The required differential input polarity depends on the output voltage setting. The amplifier output moves away from the referenced rail proportional to the current passing through the internal shunt resistor.

7.4.3 Ground Referenced Output

When using the INA253-Q1 in unidirectional mode with a ground-referenced output, both reference inputs are connected to ground. Figure 7-6 shows how this configuration takes the output to ground when there is 0-A flowing across the internal shunt.

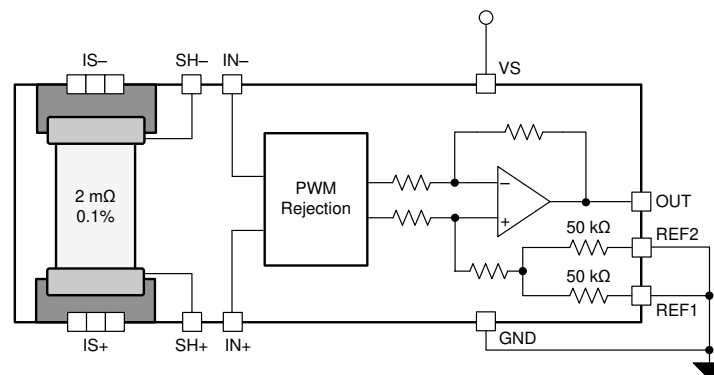

Figure 7-6. Ground-Referenced Output

7.4.4 Reference Pin Connections for Bidirectional Current Measurements

Bidirectional operation allows the INA253-Q1 to measure currents through a resistive shunt in two directions. For this case, set the output voltage anywhere within the reference input limits. A common configuration is to set the reference inputs at half-scale for equal range in both directions. However, the reference inputs can be set to a voltage other than half-scale when the bidirectional current is nonsymmetrical.

7.4.4.1 Output Set to External Reference Voltage

Connecting both pins together and then to a reference voltage results in an output voltage equal to the reference voltage for the condition of shorted input pins or a 0-V differential input. [Figure 7-7](#) shows this configuration. The output voltage decreases below the reference voltage when the IN+ pin is negative relative to the IN– pin, and increases when the IN+ pin is positive relative to the IN– pin. This technique is the most accurate way to bias the output to a precise voltage.

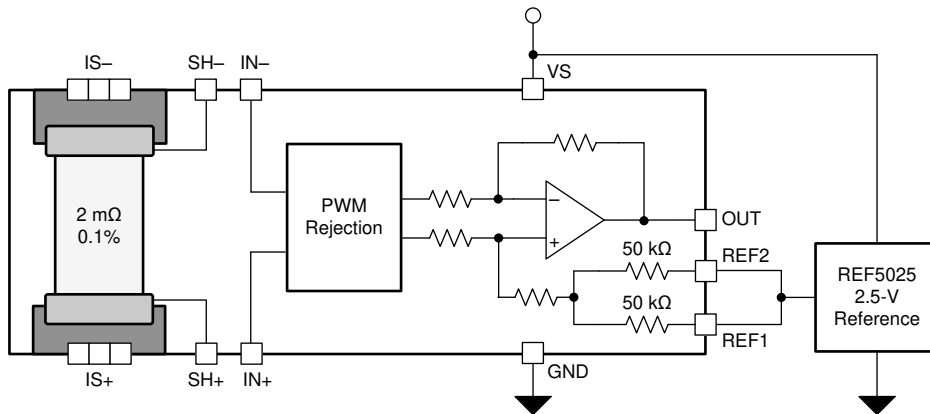

Figure 7-7. External Reference Output

7.4.5 Output Set to Mid-Supply Voltage

[Figure 7-8](#) shows that by connecting one reference pin to VS and the other to the GND pin, the output is set at half of the supply when there is no differential input. This method creates a ratiometric offset to the supply voltage, where the output voltage remains at $V_S / 2$ when 0 V is applied between the IN+ and IN– inputs.

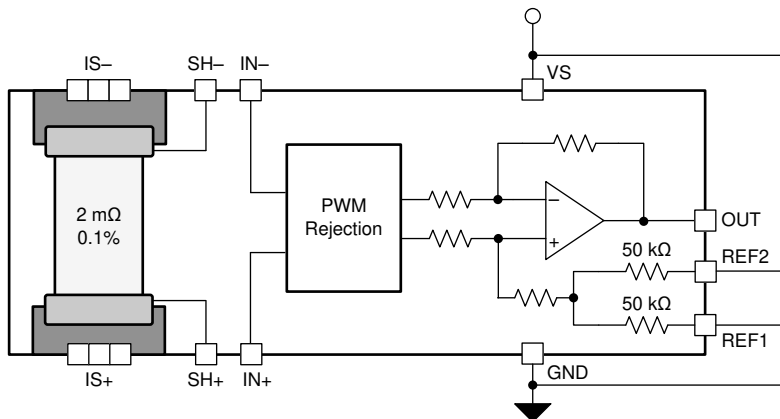

Figure 7-8. Mid-Supply Voltage Output

7.4.6 Output Set to Mid-External Reference

In this example, an external reference is divided by two by connecting one REF pin to ground and the other REF pin to the reference, as shown in [Figure 7-9](#).

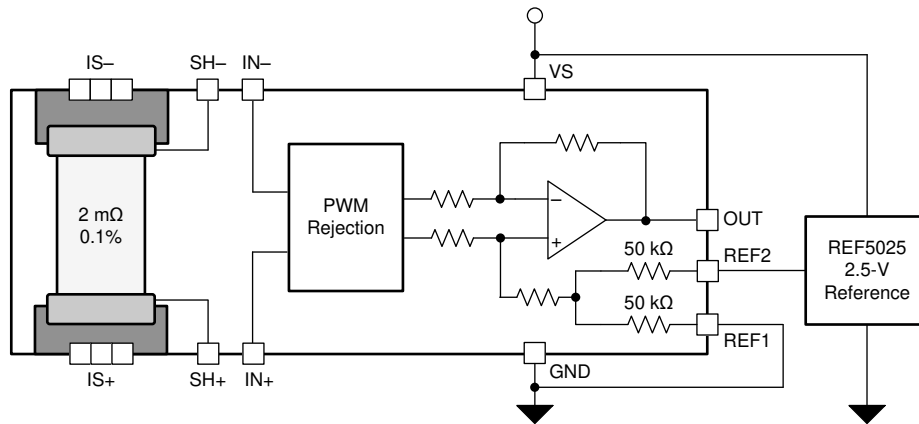

Figure 7-9. Mid-External Reference Output

7.4.7 Output Set Using Resistor Divide

The INA253-Q1 REF1 and REF2 pins allow for the midpoint of the output voltage to be adjusted for system circuitry connections to analog to digital converters (ADCs) or other amplifiers. The REF pins are designed to be connected directly to supply, ground, or a low-impedance reference voltage. The REF pins can be connected together and biased using a resistor divider to achieve a custom output voltage. If the amplifier is used in this configuration, as shown in [Figure 7-10](#), use the output as a differential signal with respect to the resistor divider voltage. For most accurate results, do not use single-ended measurements at the amplifier output because the internal impedance shifts can adversely affect device performance specifications.

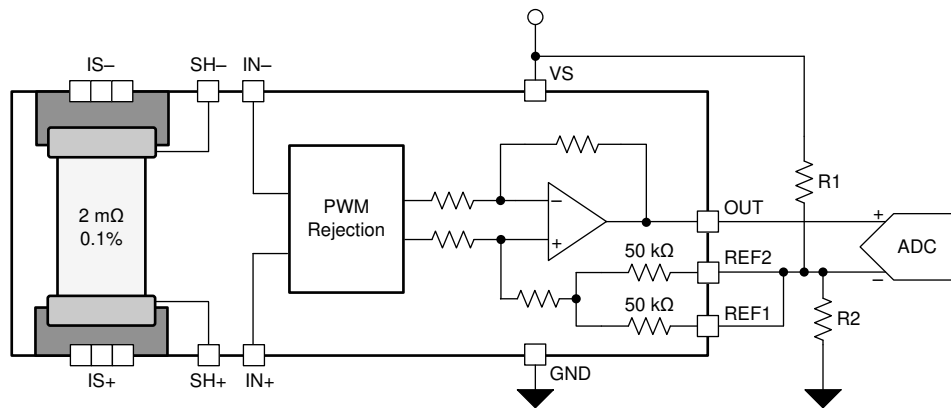

Figure 7-10. Setting the Reference Using a Resistor Divider

8 Application and Implementation

注

以下のアプリケーション情報は、TI の製品仕様に含まれるものではなく、TI ではその正確性または完全性を保証いたしません。個々の目的に対する製品の適合性については、お客様の責任で判断していただくこととなります。また、お客様は自身の設計実装を検証しテストすることで、システムの機能を確認する必要があります。

8.1 Application Information

The INA253-Q1 measures the voltage developed as current flows across the integrated low inductive current-sensing resistor. The device provides reference pins to configure operation as either unidirectional or bidirectional output swing. When using the INA253-Q1 for inline motor current sense or measuring current in an H-bridge, the device is commonly configured for bidirectional operation.

8.1.1 Input Filtering

注

Input filters are not required for accurate measurements using the INA253-Q1. For most accurate results, do not use filters at the IN+ and IN– inputs. However, If filter components are used on the input of the amplifier, follow the guidelines in this section to minimize effects on performance.

Based strictly on user design requirements, external filtering of the current signal may be desired. The initial location that can be considered for the filter is at the output of the current amplifier. Although placing the filter at the output satisfies the filtering requirements, this location changes the low output impedance measured by any circuitry connected to the output voltage pin. The other location for filter placement is at the current amplifier input pins. This location also satisfies the filtering requirement, but carefully select the components to minimize the impact on device performance. [図 8-1](#) shows a filter placed at the inputs pins.



図 8-1. Filter at Input Pins

External series resistance provides a source of additional measurement error. Therefore, keep the value of these series resistors to 10-Ω or less in order to reduce loss of accuracy. The internal bias network shown in [図 8-1](#) creates a mismatch in input bias currents when a differential voltage is applied between the input pins (see [図 8-2](#)). If additional external series filter resistors are added to the circuit, a mismatch is created in the voltage drop across the filter resistors. This voltage is a differential error voltage in the shunt resistor voltage. In addition to the absolute resistor value, mismatch resulting from resistor tolerance can significantly impact the error because this value is calculated based on the actual measured resistance.

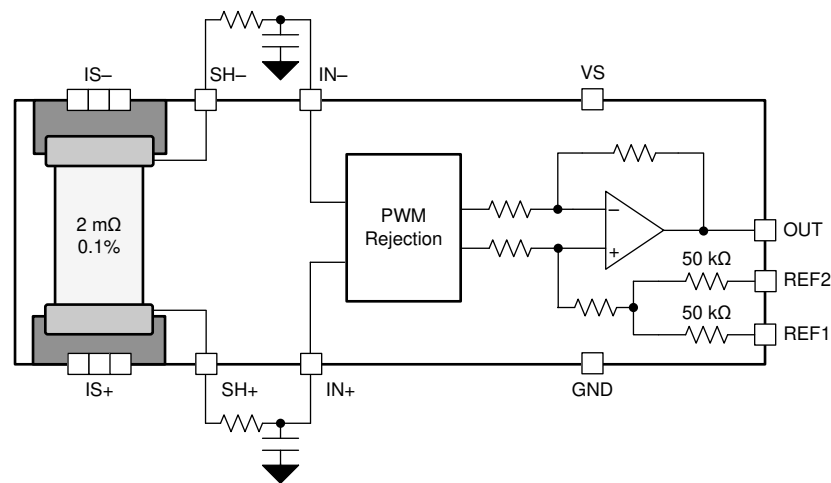

图 8-2. Input Bias Current vs Differential Input Voltage

Calculate the measurement error expected from the additional external filter resistors using 式 1.

$$\text{Gain Error (\%)} = 100 - (100 \times \text{Gain Error Factor}) \tag{1}$$

where

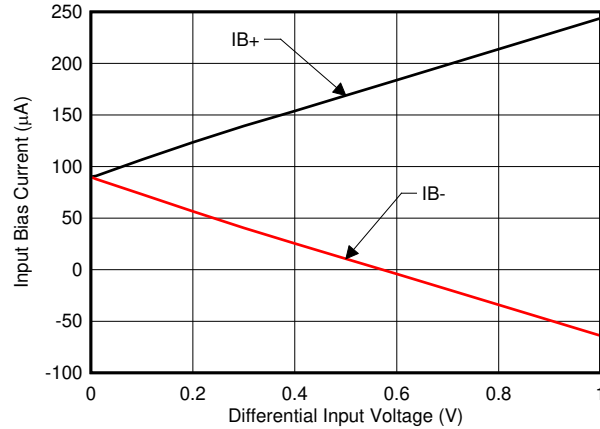
- Gain Error Factor is calculated using 式 2.

$$\text{Gain Error Factor} = \frac{3000}{R_S + 3000} \tag{2}$$

Where:

- R_S is the external filter resistance value

Calculate the gain error factor, shown in 式 2, in order to determine the gain error introduced by the additional external series resistance. 式 1 calculates the deviation of the shunt voltage resulting from the attenuation and imbalance created by the added external filter resistance. 表 8-1 provides the gain error factor and gain error for several resistor values.

表 8-1. Gain Error Factor and Gain Error for External Input Resistors

EXTERNAL RESISTANCE (Ω)	GAIN ERROR FACTOR	GAIN ERROR (%)
5	0.998	0.17
10	0.997	0.33
100	0.968	3.23

8.2 Typical Applications

The INA253-Q1 offers advantages for multiple applications including the following:

- High common-mode range and excellent CMRR enables direct inline sensing
- Precision low-inductive, low-drift shunt eliminates the need for overtemperature system calibration
- Ultra-low offset and drift eliminates the necessity of calibration
- Wide supply range enables a direct interface with most microprocessors

8.2.1 High-Side, High-Drive, Solenoid Current-Sense Application

Challenges exist in solenoid drive current sensing that are similar to those in motor inline current sensing. In certain topologies, the current-sensing amplifier is exposed to the full-scale PWM voltage between ground and supply. The INA253-Q1 is an excellent choice for this type of application. The 2-m Ω integrated shunt with a total system accuracy of 0.2% with a total system drift of 25 ppm/ $^{\circ}$ C provides system accuracy across temperature eliminating the need for tri temperature system calibration.



图 8-3. Solenoid Drive Application Circuit

8.2.1.1 Design Requirements

For this application, the INA253-Q1 measures current in the driver circuit of a 12-V, 500-mA hydraulic valve.

表 8-2. Design Parameters

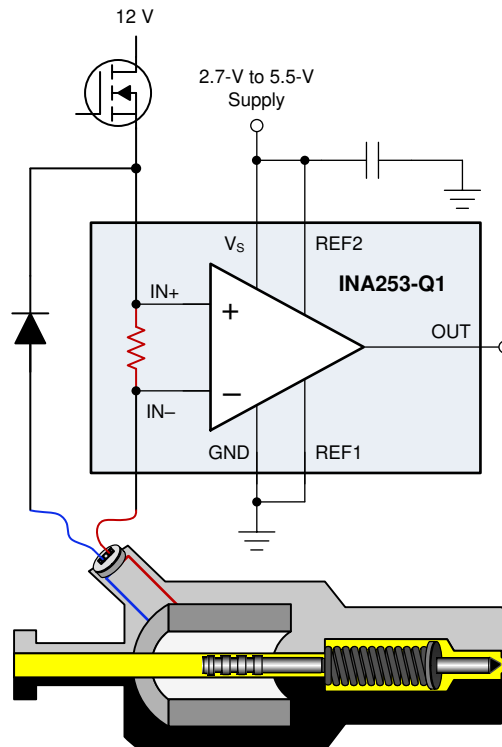
DESIGN PARAMETER	EXAMPLE VALUE
Common-mode voltage	12 V
Maximum sense current	500 mA
Power-supply voltage	3.3 V

8.2.1.2 Detailed Design Procedure

To demonstrate the performance of the device, the INA253-Q1, with a gain of 400mV/A, is selected for this design and powered from a 5-V supply.

Using the information in the [セクション 7.4.5](#) section, the reference point is set to midscale by splitting the supply with REF1 connected to ground and REF2 connected to supply. Alternatively, the reference pins can be tied together and driven with an external precision reference.

8.2.1.3 Application Curve

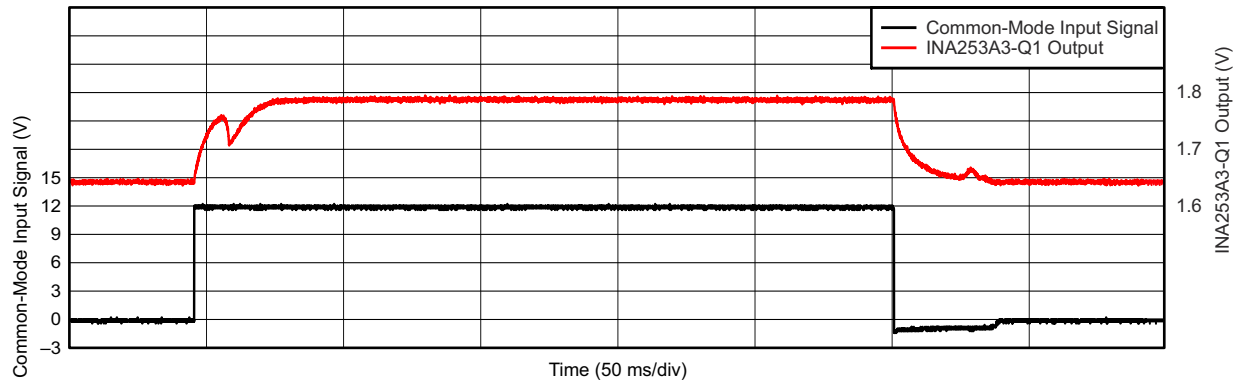

8-4. Solenoid Drive Current Sense Input and Output Signals

8.2.2 Speaker Enhancements and Diagnostics Using Current Sense Amplifier

CLASS-D audio amplifiers in conjunction with the INA253-Q1 provide accurate speaker load current. Speaker load current is used to determine speaker diagnostics, and can further be expanded to measure key speaker parameters, such as speaker coil resistance and speaker real-time ambient temperature.



图 8-5. Current Sensing in a CLASS-D Subsystem

8.2.2.1 Design Requirements

表 8-3. Design Parameters

DESIGN PARAMETER	EXAMPLE VALUE
Common-mode voltage	24 V
Power-supply voltage	5 V
Maximum rms current	5 A
Frequency sweep	20 Hz to 20 KHz

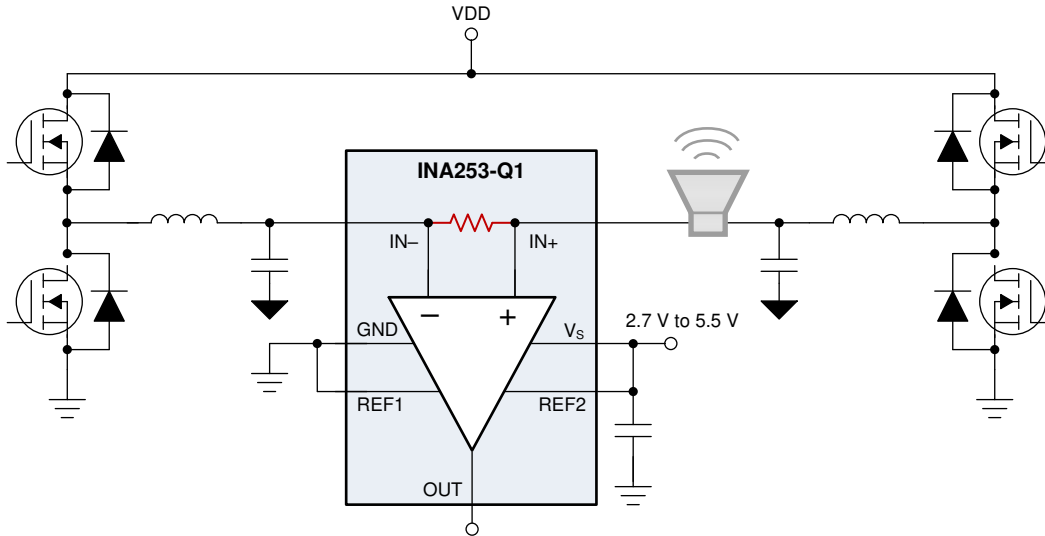
8.2.2.2 Detailed Design Procedure

For this application, the INA253-Q1 measures current flowing through the speaker from the CLASS-D amplifier. The integrated shunt of 2 mΩ with an inductance of only 3 nH is an excellent choice for current sensing in speaker applications where low inductance is required. The low-inductive shunt enables accurate current sensing across frequencies over the audio range of 20 Hz to 20 kHz.

The INA253-Q1 is setup in a bidirectional with the reference set to mid-supply as shown in 图 7-9. The power supply to INA253-Q1 is setup at 5 V. The output of INA253-Q1 is set at 2.5 V. The INA253-Q1 with a gain of 100 mV/A, the INA253-Q1 output for a peak to peak of 10-A current the output of the INA253-Q1 will swing from 3.5 V to 1.5 V. The output can be directly connected to ADC input that has a full scale range of 5 V. The INA253-Q1 has a low THD+N of 0.1% at 1 kHz that enables distortion measurement of speaker. The INA253-Q1 can measure the impedance of the speaker and accurately measure the resonance frequency and peak impedance at resonance frequency. The INA253-Q1 can accurately track changes in impedance real time.

8.2.2.3 Application Curve

A typical example output response of speaker of 4-Ω impedance measurement from 20 Hz to 20 kHz is as shown in [Figure 8-6](#).

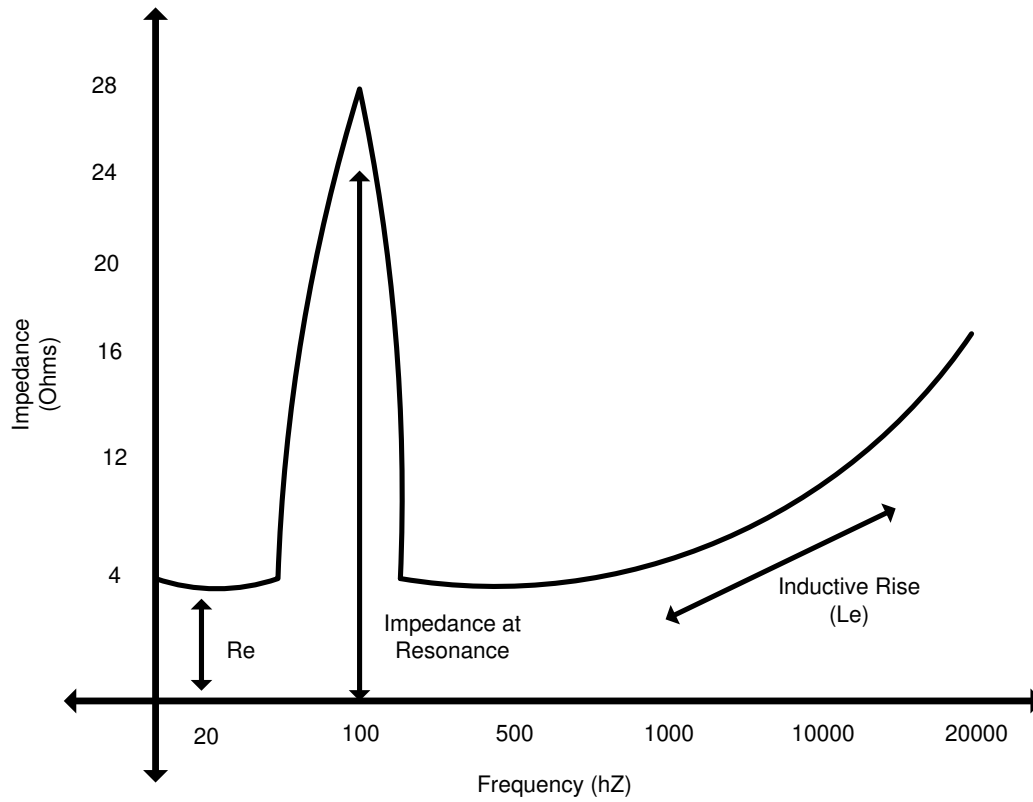

Figure 8-6. Speaker Impedance Measurement

9 Power Supply Recommendations

The INA253-Q1 makes accurate measurements beyond the connected power-supply voltage (V_S) because the inputs (IN+ and IN–) operate anywhere between -4 V and $+80$ V, independent of V_S . For example, the V_S power supply equals 5 V and the common-mode voltage of the measured shunt can be as high as 80 V. Although the common-mode voltage of the input can be beyond the supply voltage, the output voltage range of the INA253-Q1 is constrained to the supply voltage.

Place the power-supply bypass capacitor as close as possible to the supply and ground pins. The recommended value of this bypass capacitor is 0.1 μ F. Additional decoupling capacitance can be added to compensate for noisy or high-impedance power supplies. If the INA253-Q1 output is set to mid-supply, then take extreme care to minimize noise on the power supply.

10 Layout

10.1 Layout Guidelines

- This device is specified for current handling of up to 10 A over the entire $-40\text{ }^{\circ}\text{C}$ to $+125\text{ }^{\circ}\text{C}$ temperature range using a 1-oz copper pour for the input power plane, as well as no external airflow passing over the device.
- The primary current-handling limitation for this device is how much heat is dissipated inside the package. Efforts to improve heat transfer out of the package and into the surrounding environment improve the ability of the device to handle currents of up to 15 A over the entire $-40\text{ }^{\circ}\text{C}$ to $+125\text{ }^{\circ}\text{C}$ temperature range.
- Heat transfer improvements primarily involve larger copper power traces and planes with increased copper thickness (2 oz), as well as providing airflow to pass over the device. The INA253-Q1 evaluation module (EVM) features a 2-oz copper pour for the planes, and is capable of supporting 15 A at temperatures up to $125\text{ }^{\circ}\text{C}$.
- Place the power-supply bypass capacitor as close as possible to the supply and ground pins. The recommended value of this bypass capacitor is $0.1\text{ }\mu\text{F}$. Additional decoupling capacitance can be added to compensate for noisy or high-impedance power supplies.

10.2 Layout Example

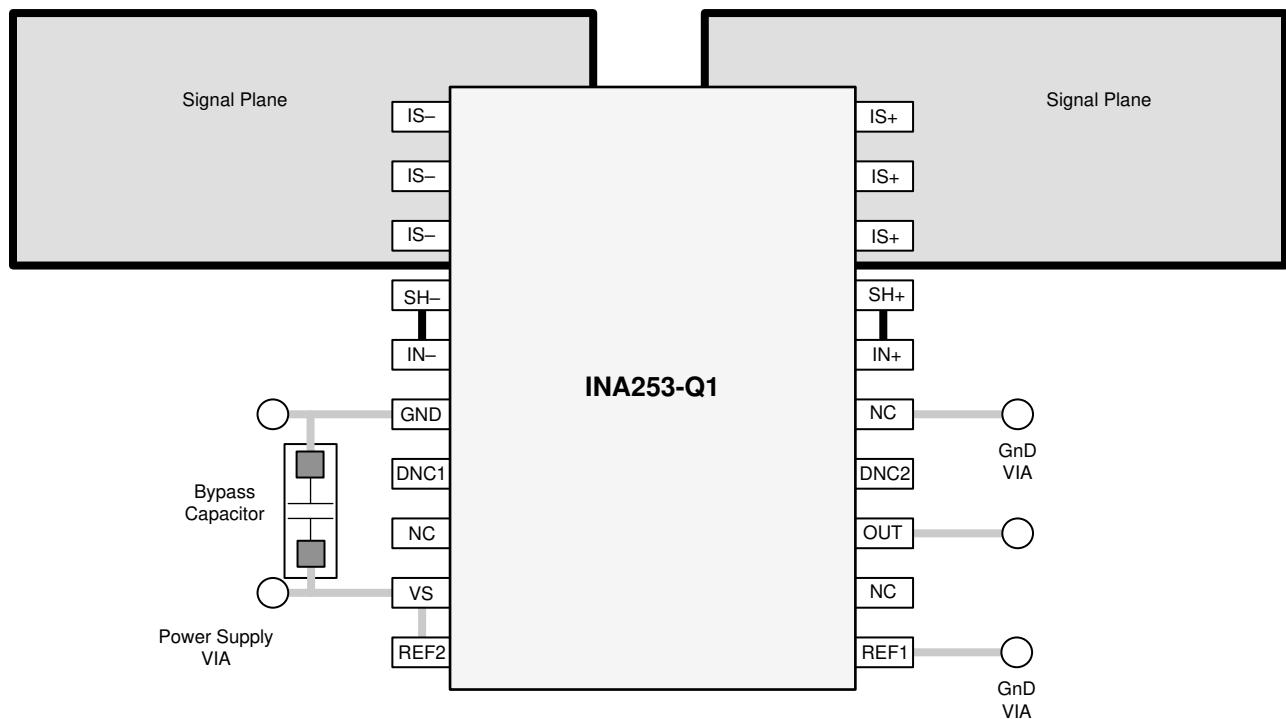

 10-1. INA253-Q1 Layout Example

11 Device and Documentation Support

11.1 Device Support

11.1.1 Development Support

[INA253 Evaluation Module \(EVM\)](#)

11.2 Related Documentation

For related documentation see the following: Texas Instruments, [INA253EVM user's guide](#)

11.3 ドキュメントの更新通知を受け取る方法

ドキュメントの更新についての通知を受け取るには、[ti.com](#) のデバイス製品フォルダを開いてください。「更新の通知を受け取る」をクリックして登録すると、変更されたすべての製品情報に関するダイジェストを毎週受け取れます。変更の詳細については、修正されたドキュメントに含まれている改訂履歴をご覧ください。

11.4 サポート・リソース

[TI E2E™ サポート・フォーラム](#)は、エンジニアが検証済みの回答と設計に関するヒントをエキスパートから迅速かつ直接得ることができる場所です。既存の回答を検索したり、独自の質問をしたりすることで、設計に必要な支援を迅速に得ることができます。

リンクされているコンテンツは、該当する貢献者により、現状のまま提供されるものです。これらは TI の仕様を構成するものではなく、必ずしも TI の見解を反映したものではありません。TI の[使用条件](#)を参照してください。

11.5 Trademarks

TI E2E™ is a trademark of Texas Instruments.

すべての商標は、それぞれの所有者に帰属します。

11.6 静電気放電に関する注意事項



この IC は、ESD によって破損する可能性があります。テキサス・インスツルメンツは、IC を取り扱う際には常に適切な注意を払うことを推奨します。正しい ESD 対策をとらないと、デバイスを破損するおそれがあります。

ESD による破損は、わずかな性能低下からデバイスの完全な故障まで多岐にわたります。精密な IC の場合、パラメータがわずかに変化するだけで公表されている仕様から外れる可能性があるため、破損が発生しやすくなっています。

11.7 用語集

[TI 用語集](#) この用語集には、用語や略語の一覧および定義が記載されています。

12 Mechanical, Packaging, and Orderable Information

The following pages include mechanical, packaging, and orderable information. This information is the most current data available for the designated devices. This data is subject to change without notice and revision of this document. For browser-based versions of this data sheet, refer to the left-hand navigation.

PACKAGING INFORMATION

Orderable part number	Status (1)	Material type (2)	Package Pins	Package qty Carrier	RoHS (3)	Lead finish/ Ball material (4)	MSL rating/ Peak reflow (5)	Op temp (°C)	Part marking (6)
INA253A1QPWRQ1	Active	Production	TSSOP (PW) 20	2000 LARGE T&R	Yes	NIPDAU	Level-2-260C-1 YEAR	-40 to 125	Q253A1
INA253A1QPWRQ1.A	Active	Production	TSSOP (PW) 20	2000 LARGE T&R	Yes	NIPDAU	Level-2-260C-1 YEAR	-40 to 125	Q253A1
INA253A2QPWRQ1	Active	Production	TSSOP (PW) 20	2000 LARGE T&R	Yes	NIPDAU	Level-2-260C-1 YEAR	-40 to 125	Q253A2
INA253A2QPWRQ1.A	Active	Production	TSSOP (PW) 20	2000 LARGE T&R	Yes	NIPDAU	Level-2-260C-1 YEAR	-40 to 125	Q253A2
INA253A3QPWRQ1	Active	Production	TSSOP (PW) 20	2000 LARGE T&R	Yes	NIPDAU	Level-2-260C-1 YEAR	-40 to 125	Q253A3
INA253A3QPWRQ1.A	Active	Production	TSSOP (PW) 20	2000 LARGE T&R	Yes	NIPDAU	Level-2-260C-1 YEAR	-40 to 125	Q253A3

(1) **Status:** For more details on status, see our [product life cycle](#).

(2) **Material type:** When designated, preproduction parts are prototypes/experimental devices, and are not yet approved or released for full production. Testing and final process, including without limitation quality assurance, reliability performance testing, and/or process qualification, may not yet be complete, and this item is subject to further changes or possible discontinuation. If available for ordering, purchases will be subject to an additional waiver at checkout, and are intended for early internal evaluation purposes only. These items are sold without warranties of any kind.

(3) **RoHS values:** Yes, No, RoHS Exempt. See the [TI RoHS Statement](#) for additional information and value definition.

(4) **Lead finish/Ball material:** Parts may have multiple material finish options. Finish options are separated by a vertical ruled line. Lead finish/Ball material values may wrap to two lines if the finish value exceeds the maximum column width.

(5) **MSL rating/Peak reflow:** The moisture sensitivity level ratings and peak solder (reflow) temperatures. In the event that a part has multiple moisture sensitivity ratings, only the lowest level per JEDEC standards is shown. Refer to the shipping label for the actual reflow temperature that will be used to mount the part to the printed circuit board.

(6) **Part marking:** There may be an additional marking, which relates to the logo, the lot trace code information, or the environmental category of the part.

Multiple part markings will be inside parentheses. Only one part marking contained in parentheses and separated by a "~" will appear on a part. If a line is indented then it is a continuation of the previous line and the two combined represent the entire part marking for that device.

Important Information and Disclaimer: The information provided on this page represents TI's knowledge and belief as of the date that it is provided. TI bases its knowledge and belief on information provided by third parties, and makes no representation or warranty as to the accuracy of such information. Efforts are underway to better integrate information from third parties. TI has taken and continues to take reasonable steps to provide representative and accurate information but may not have conducted destructive testing or chemical analysis on incoming materials and chemicals. TI and TI suppliers consider certain information to be proprietary, and thus CAS numbers and other limited information may not be available for release.

In no event shall TI's liability arising out of such information exceed the total purchase price of the TI part(s) at issue in this document sold by TI to Customer on an annual basis.

OTHER QUALIFIED VERSIONS OF INA253-Q1 :

- Catalog : [INA253](#)

NOTE: Qualified Version Definitions:

- Catalog - TI's standard catalog product

TAPE AND REEL INFORMATION

QUADRANT ASSIGNMENTS FOR PIN 1 ORIENTATION IN TAPE

*All dimensions are nominal

Device	Package Type	Package Drawing	Pins	SPQ	Reel Diameter (mm)	Reel Width W1 (mm)	A0 (mm)	B0 (mm)	K0 (mm)	P1 (mm)	W (mm)	Pin1 Quadrant
INA253A1QPWRQ1	TSSOP	PW	20	2000	330.0	16.4	6.95	7.0	1.4	8.0	16.0	Q1
INA253A2QPWRQ1	TSSOP	PW	20	2000	330.0	16.4	6.95	7.0	1.4	8.0	16.0	Q1
INA253A3QPWRQ1	TSSOP	PW	20	2000	330.0	16.4	6.95	7.0	1.4	8.0	16.0	Q1

TAPE AND REEL BOX DIMENSIONS

*All dimensions are nominal

Device	Package Type	Package Drawing	Pins	SPQ	Length (mm)	Width (mm)	Height (mm)
INA253A1QPWRQ1	TSSOP	PW	20	2000	353.0	353.0	32.0
INA253A2QPWRQ1	TSSOP	PW	20	2000	353.0	353.0	32.0
INA253A3QPWRQ1	TSSOP	PW	20	2000	353.0	353.0	32.0

PW0020A



PACKAGE OUTLINE
TSSOP - 1.2 mm max height

SMALL OUTLINE PACKAGE



4220206/A 02/2017

EXAMPLE BOARD LAYOUT

PW0020A

TSSOP - 1.2 mm max height

SMALL OUTLINE PACKAGE



LAND PATTERN EXAMPLE
EXPOSED METAL SHOWN
SCALE: 10X



SOLDER MASK DETAILS

4220206/A 02/2017

NOTES: (continued)

- 6. Publication IPC-7351 may have alternate designs.
- 7. Solder mask tolerances between and around signal pads can vary based on board fabrication site.

EXAMPLE STENCIL DESIGN

PW0020A

TSSOP - 1.2 mm max height

SMALL OUTLINE PACKAGE



SOLDER PASTE EXAMPLE
BASED ON 0.125 mm THICK STENCIL
SCALE: 10X

4220206/A 02/2017

NOTES: (continued)

8. Laser cutting apertures with trapezoidal walls and rounded corners may offer better paste release. IPC-7525 may have alternate design recommendations.
9. Board assembly site may have different recommendations for stencil design.

重要なお知らせと免責事項

TI は、技術データと信頼性データ(データシートを含みます)、設計リソース(リファレンス デザインを含みます)、アプリケーションや設計に関する各種アドバイス、Web ツール、安全性情報、その他のリソースを、欠陥が存在する可能性のある「現状のまま」提供しており、商品性および特定目的に対する適合性の黙示保証、第三者の知的財産権の非侵害保証を含むいかなる保証も、明示的または黙示的にかかわらず拒否します。

これらのリソースは、TI 製品を使用する設計の経験を積んだ開発者への提供を意図したものです。(1) お客様のアプリケーションに適した TI 製品の選定、(2) お客様のアプリケーションの設計、検証、試験、(3) お客様のアプリケーションに該当する各種規格や、その他のあらゆる安全性、セキュリティ、規制、または他の要件への確実な適合に関する責任を、お客様のみが単独で負うものとし、

上記の各種リソースは、予告なく変更される可能性があります。これらのリソースは、リソースで説明されている TI 製品を使用するアプリケーションの開発の目的でのみ、TI はその使用をお客様に許諾します。これらのリソースに関して、他の目的で複製することや掲載することは禁止されています。TI や第三者の知的財産権のライセンスが付与されている訳ではありません。お客様は、これらのリソースを自身で使用した結果発生するあらゆる申し立て、損害、費用、損失、責任について、TI およびその代理人を完全に補償するものとし、TI は一切の責任を拒否します。

TI の製品は、[TI の販売条件](#)、[TI の総合的な品質ガイドライン](#)、[ti.com](#) または TI 製品などに関連して提供される他の適用条件に従い提供されます。TI がこれらのリソースを提供することは、適用される TI の保証または他の保証の放棄の拡大や変更を意味するものではありません。TI がカスタム、またはカスタマー仕様として明示的に指定していない限り、TI の製品は標準的なカタログに掲載される汎用機器です。

お客様がいかなる追加条項または代替条項を提案する場合も、TI はそれらに異議を唱え、拒否します。

Copyright © 2025, Texas Instruments Incorporated

最終更新日：2025 年 10 月