

## INA19xA-Q1 電流シャント・モニタ、同相電圧範囲 -16V~80V

### 1 特長

- 車載アプリケーション向けに認定済み
- 機能安全対応
  - 機能安全システムの設計に役立つ資料を利用可能
- 広い同相電圧範囲:  
-16V~80V
- 低い誤差:3%の過熱(最大値)
- 帯域幅:最高 500kHz
- 3つの伝達関数を使用可能:20V/V、50V/V、100V/V
- 完全な電流検出ソリューション

### 2 アプリケーション

- 溶接機器
- ボディ・コントロール・モジュール
- 負荷の正常性監視
- 通信機器
- HEV/EV パワートレイン
- パワー・マネージメント
- バッテリ充電器

### 3 概要

電圧出力機能を備えた INA19xA-Q1 ファミリの電流シャント・モニタは、INA19xA の電源電圧に関わらず、-16V~80V の同相モード電圧でシャントにおける電圧降下を検出できます。これらの製品は、以下の 3 種類の出力電圧スケールで供給されます。20V/V、50V/V、100V/V。500kHz の帯域幅により、電流制御ループの使用や DC モーターの状態監視が簡単になります。INA193A~INA195A は、それぞれ INA196A~INA198A と機能は同じですが、ピン割り当てが異なります。

INA19xA-Q1 は、2.7V~18V の単電源で動作します。これらは動作温度範囲仕様が広く (-40°C~125°C)、省スペースな SOT-23 パッケージで供給されます。

#### 製品情報(1)

部品番号	パッケージ	本体サイズ (公称)
INA19xA-Q1	SOT-23 (5)	2.90mm × 1.60mm

- (1) 利用可能なすべてのパッケージについては、データシートの末尾にあるパッケージ・オプションについての付録を参照してください。

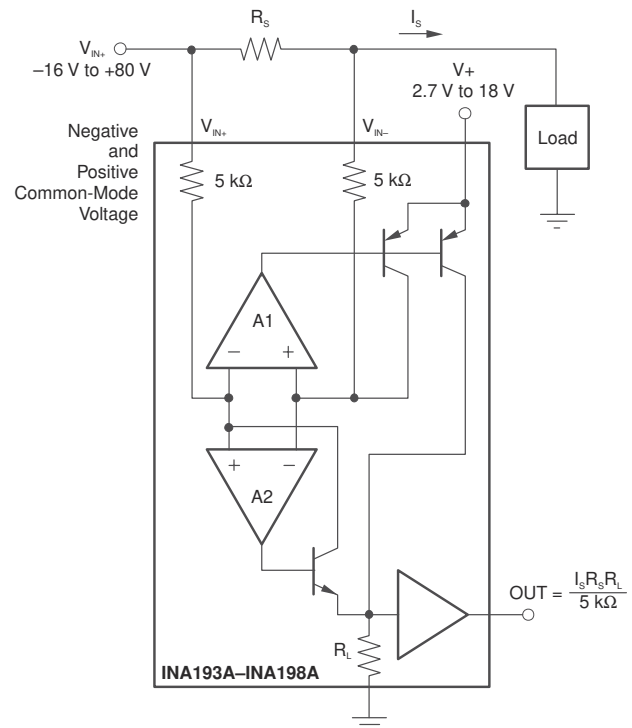

簡略回路図



## Table of Contents

<b>1 特長</b> .....	1	7.4 Device Functional Modes.....	16
<b>2 アプリケーション</b> .....	1	<b>8 Application and Implementation</b> .....	20
<b>3 概要</b> .....	1	8.1 Application Information.....	20
<b>4 Revision History</b> .....	2	8.2 Typical Application.....	20
<b>5 Pin Configuration and Functions</b> .....	3	<b>9 Power Supply Recommendations</b> .....	21
<b>6 Specifications</b> .....	4	<b>10 Layout</b> .....	22
6.1 Absolute Maximum Ratings.....	4	10.1 Layout Guidelines.....	22
6.2 ESD Ratings.....	4	10.2 Layout Example.....	22
6.3 Recommended Operating Conditions.....	4	<b>11 Device and Documentation Support</b> .....	23
6.4 Thermal Information.....	4	11.1 ドキュメントの更新通知を受け取る方法.....	23
6.5 Electrical Characteristics.....	5	11.2 サポート・リソース.....	23
6.6 Typical Characteristics.....	7	11.3 Trademarks.....	23
<b>7 Detailed Description</b> .....	11	11.4 静電気放電に関する注意事項.....	23
7.1 Overview.....	11	11.5 用語集.....	23
7.2 Functional Block Diagram.....	11	<b>12 Mechanical, Packaging, and Orderable Information</b> .....	23
7.3 Feature Description.....	11		

## 4 Revision History

資料番号末尾の英字は改訂を表しています。その改訂履歴は英語版に準じています。

### Changes from Revision D (July 2015) to Revision E (January 2021) Page

- 文書全体の表、図、相互参照の採番方法を更新..... 1
- 機能安全の箇条書き項目を追加..... 1

### Changes from Revision C (October 2008) to Revision D (July 2015) Page

- 「ESD 定格」表、「機能説明」セクション、「デバイスの機能モード」セクション、「アプリケーションと実装」セクション、「電源に関する推奨事項」セクション、「レイアウト」セクション、「デバイスおよびドキュメントのサポート」セクション、「メカニカル、パッケージ、および注文情報」セクションを追加 ..... 1
- Added Input Bias Current vs Common Mode Voltage  $V_s=5$  V graph to *Typical Characteristics* ..... 7
- Added Input Bias Current vs Common Mode Voltage  $V_s=12$  V graph to *Typical Characteristics* ..... 7

## 5 Pin Configuration and Functions



图 5-1. DBV Package 5-Pin SOT-23 INA193A-Q1, INA194A-Q1, INA195A-Q1 Top View



图 5-2. DBV Package 5-Pin SOT-23 INA196A-Q1, INA197A-Q1, INA198A-Q1 Top View

表 5-1. Pin Functions

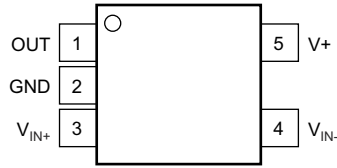
NAME	PIN		TYPE	DESCRIPTION
	INA193A-Q1, INA194A-Q1, INA195A-Q1	INA196A-Q1, INA197A-Q1, INA198A-Q1		
GND	2	2	GND	Ground
OUT	1	1	O	Output voltage
V+	5	3	Analog	Power supply, 2.7 to 18 V
V <sub>IN+</sub>	3	4	I	Connect to supply side of shunt resistor
V <sub>IN-</sub>	4	5	I	Connect to load side of shunt resistor

## 6 Specifications

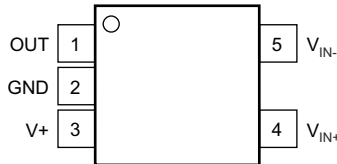
### 6.1 Absolute Maximum Ratings

over operating free-air temperature range (unless otherwise noted)<sup>(1)</sup>

	MIN	MAX	UNIT
Supply voltage		18	V
Differential input voltage range, analog inputs ( $V_{IN+} - V_{IN-}$ )	-18	18	V
Common-mode voltage range <sup>(2)</sup>	-16	80	V
Analog output voltage range <sup>(2)</sup>	OUT	GND - 0.3 (V+) + 0.3	V
Input current into any pin <sup>(2)</sup>		5	mA
Junction temperature		150	°C
Storage temperature, $T_{stg}$	-65	150	°C

- (1) Stresses beyond those listed under *Absolute Maximum Ratings* may cause permanent damage to the device. These are stress ratings only, which do not imply functional operation of the device at these or any other conditions beyond those indicated under *Recommended Operating Conditions*. Exposure to absolute-maximum-rated conditions for extended periods may affect device reliability.
- (2) Input voltage at any pin may exceed the voltage shown if the current at that pin is limited to 5 mA.

### 6.2 ESD Ratings

	VALUE	UNIT
$V_{(ESD)}$ Electrostatic discharge	Human-body model (HBM), per AEC Q100-002 <sup>(1)</sup>	±4000
	Charged-device model (CDM), per AEC Q100-011	±1000
	Machine model	±200

- (1) AEC Q100-002 indicates that HBM stressing shall be in accordance with the ANSI/ESDA/JEDEC JS-001 specification.

### 6.3 Recommended Operating Conditions

over operating free-air temperature range (unless otherwise noted)

	MIN	NOM	MAX	UNIT
$V_{CM}$ Common-mode input voltage		12		V
$V+$ Operating supply voltage		12		V
$T_A$ Operating free-air temperature	-40		125	°C

### 6.4 Thermal Information

THERMAL METRIC <sup>(1)</sup>		INA19xA-Q1	UNIT
		DBV (SOT-23)	
		5 PINS	
$R_{\theta JA}$	Junction-to-ambient thermal resistance	221.7	°C/W
$R_{\theta JC(top)}$	Junction-to-case (top) thermal resistance	144.7	°C/W
$R_{\theta JB}$	Junction-to-board thermal resistance	49.7	°C/W
$\Psi_{JT}$	Junction-to-top characterization parameter	26.1	°C/W
$\Psi_{JB}$	Junction-to-board characterization parameter	49	°C/W

- (1) For more information about traditional and new thermal metrics, see the *Semiconductor and IC Package Thermal Metrics* application report, [SPRA953](http://www.ti.com/lit/zip/Spra953).

## 6.5 Electrical Characteristics

 $V_S = 12\text{ V}$ ,  $V_{IN+} = 12\text{ V}$ ,  $V_{SENSE} = 100\text{ mV}$  (unless otherwise noted) Full range  $T_A = -40^\circ\text{C}$  to  $125^\circ\text{C}$ 

PARAMETER		TEST CONDITIONS	$T_A$	MIN	TYP	MAX	UNIT	
<b>INPUT</b>								
$V_{SENSE}$	Full-scale input voltage	$V_{SENSE} = V_{IN+} - V_{IN-}$	$25^\circ\text{C}$		$0.15 \frac{(V_S - 0.2)}{\text{Gain}}$		V	
VCM	Common-mode input		Full range	-16		80	V	
CMR	Common-mode rejection	$V_{IN+} = -16\text{ V to } 80\text{ V}$	$25^\circ\text{C}$	80	94		dB	
		$V_{IN+} = 12\text{ V to } 80\text{ V}$	Full range	100	120			
$V_{OS}$	Offset voltage, RTI		$25^\circ\text{C}$		$\pm 0.5$	2	mV	
			Full range		0.5	3		
$dV_{OS}/dT$	Offset voltage vs temperature		Full range		2.5		$\mu\text{V}/^\circ\text{C}$	
PSR	Offset voltage vs power supply	$V_S = 2.7\text{ V to } 18\text{ V}$ , $V_{IN+} = 18\text{ V}$	Full range		5	100	$\mu\text{V}/\text{V}$	
$I_B$	Input bias current	$V_{IN-}$ pin	Full range		$\pm 8$	$\pm 23$	$\mu\text{A}$	
<b>OUTPUT (<math>V_{SENSE} \geq 20\text{ mV}</math>)</b>								
G	Gain	INA193A, INA196A	$25^\circ\text{C}$		20		V/V	
		INA194A, INA197A			50			
		INA195A, INA198A			100			
	Gain error	$V_{SENSE} = 20\text{ mV to } 100\text{ mV}$	$25^\circ\text{C}$		$\pm 0.2\%$	$\pm 1\%$		
			Full range			$\pm 2\%$		
	Total output error <sup>(1)</sup>		$25^\circ\text{C}$		$\pm 0.75\%$	$\pm 2.2\%$		
			Full range		$\pm 1\%$	$\pm 3\%$		
	Nonlinearity error	$V_{SENSE} = 20\text{ mV to } 100\text{ mV}$	$25^\circ\text{C}$		$\pm 0.002\%$	$\pm 0.1\%$		
$R_O$	Output impedance		$25^\circ\text{C}$		1.5		$\Omega$	
	Maximum capacitive load	No sustained oscillation	$25^\circ\text{C}$		10		nF	
<b>OUTPUT (<math>V_{SENSE} &lt; 20\text{ mV}</math>) <sup>(4)</sup></b>								
$V_{OUT}$	Output voltage	All devices	$25^\circ\text{C}$	$-16\text{ V} \leq V_{CM} < 0$	300		mV	
				$V_S < V_{CM} \leq 80\text{ V}$	300			
		INA193A, INA196A		$0\text{ V} \leq V_{CM} \leq V_S$ , $V_S = 5\text{ V}$		0.4		V
		INA194A, INA197A				1		
INA195A, INA198A			2					
<b>VOLTAGE OUTPUT<sup>(2)</sup></b>								
	Swing to $V_+$ power-supply rail	$R_L = 100\text{ k}\Omega$ to GND	Full range		$V_+ - 0.1$	$V_+ - 0.2$	V	
	Swing to GND <sup>(3)</sup>	$R_L = 100\text{ k}\Omega$ to GND	Full range		$V_{GND} + 3$	$V_{GND} + 50$	mV	

$V_S = 12\text{ V}$ ,  $V_{IN+} = 12\text{ V}$ ,  $V_{SENSE} = 100\text{ mV}$  (unless otherwise noted) Full range  $T_A = -40^\circ\text{C}$  to  $125^\circ\text{C}$

PARAMETER		TEST CONDITIONS		$T_A$	MIN	TYP	MAX	UNIT
<b>FREQUENCY RESPONSE</b>								
BW	Bandwidth	INA193A, INA196A	$C_{LOAD} = 5\text{ pF}$	$25^\circ\text{C}$		500		kHz
		INA194A, INA197A				300		
		INA195A, INA198A				200		
	Phase margin	$C_{LOAD} < 10\text{ nF}$		$25^\circ\text{C}$		40		$^\circ$
SR	Slew rate					1		$\text{V}/\mu\text{s}$
$t_s$	Settling time (1%)	$V_{SENSE} = 10\text{ mV}$ to $100\text{ mV}_{PP}$ , $C_{LOAD} = 5\text{ pF}$		$25^\circ\text{C}$		2		$\mu\text{s}$
<b>NOISE, RTI</b>								
	Voltage noise density			$25^\circ\text{C}$		40		$\text{nV}/\sqrt{\text{Hz}}$
<b>POWER SUPPLY</b>								
$V_S$	Operating voltage			Full range	2.7		18	V
$I_Q$	Quiescent current	$V_{OUT} = 2\text{ V}$		Full range		700	1250	$\mu\text{A}$
		INA193A, INA194A, INA196A, INA197A	$V_{SENSE} = 0\text{ mV}$	Full range		370	950	
		INA195A, INA198A				370	1050	
<b>TEMPERATURE RANGE</b>								
	Operating temperature				-40		125	$^\circ\text{C}$
	Storage temperature				-65		150	$^\circ\text{C}$

- (1) Total output error includes effects of gain error and  $V_{OS}$ .
- (2) See [Figure 6-7](#).
- (3) Specified by design
- (4) For details on this region of operation, see [Section 7.4.2](#).

## 6.6 Typical Characteristics

$T_A = 25^\circ\text{C}$ ,  $V_S = 12\text{ V}$ ,  $V_{IN+} = 12\text{ V}$ , and  $V_{SENSE} = 100\text{ mV}$  (unless otherwise noted)

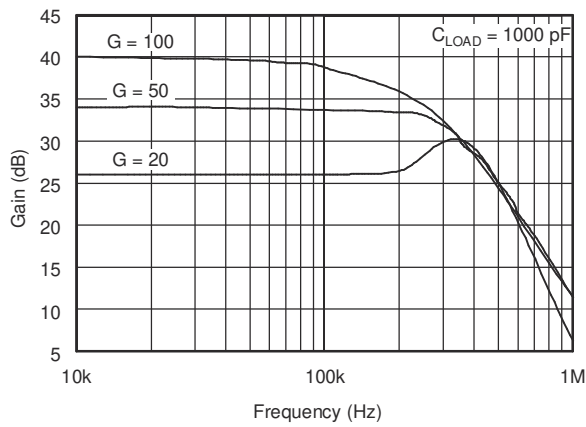

**6-1. Gain vs Frequency**

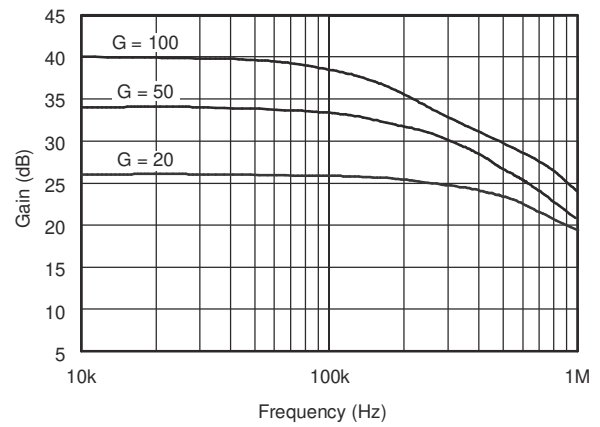

**6-2. Gain vs Frequency**

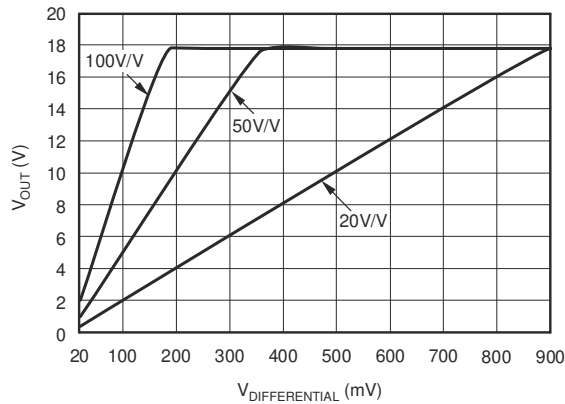

**6-3. Gain Plot**

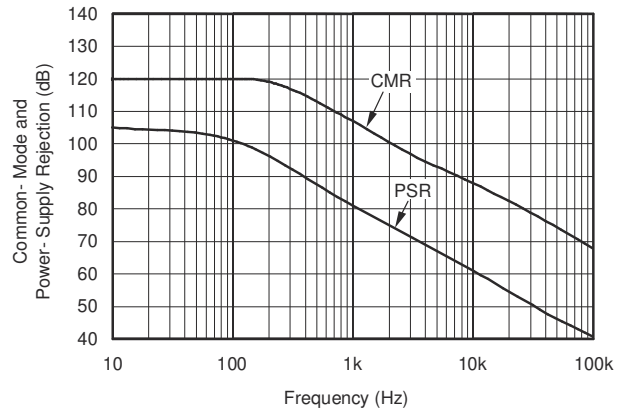

**6-4. Common-Mode and Power-Supply Rejection vs Frequency**

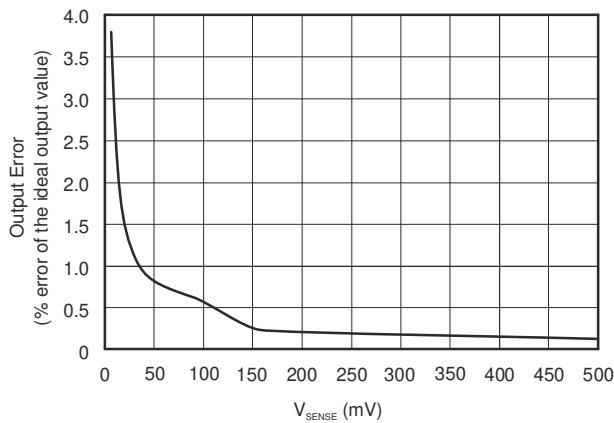

**6-5. Output Error vs Vsense**

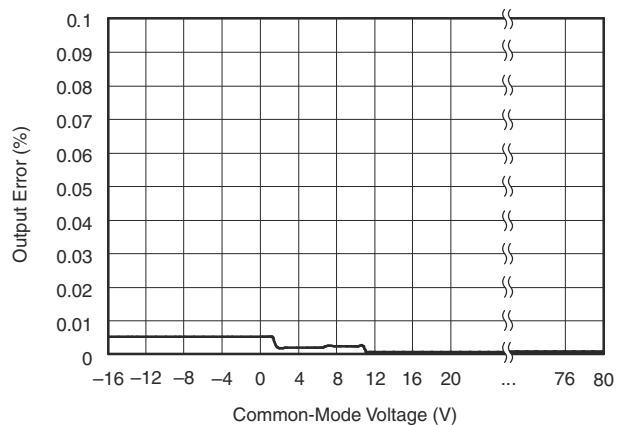

**6-6. Output Error vs Common-Mode Voltage**

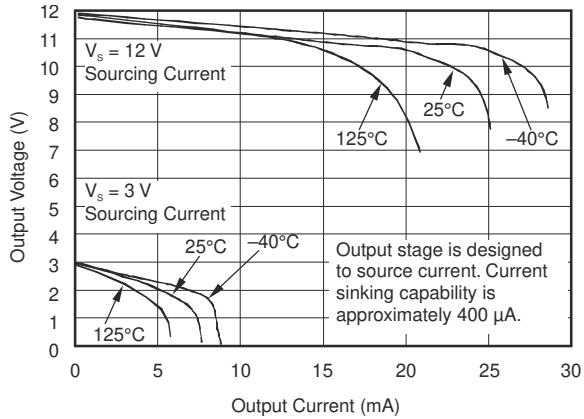

**6-7. Positive Output Voltage Swing vs Output Current**

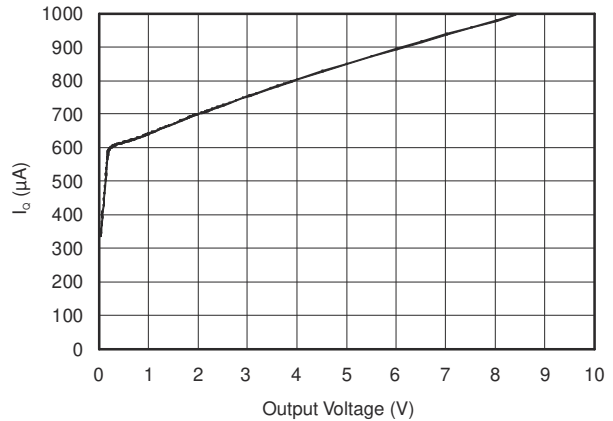

**6-8. Quiescent Current vs Output Voltage**

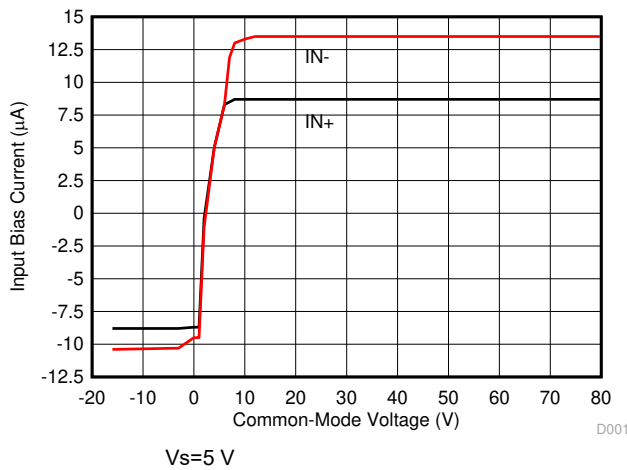

**6-9. Input Bias Current vs Common Mode Voltage**

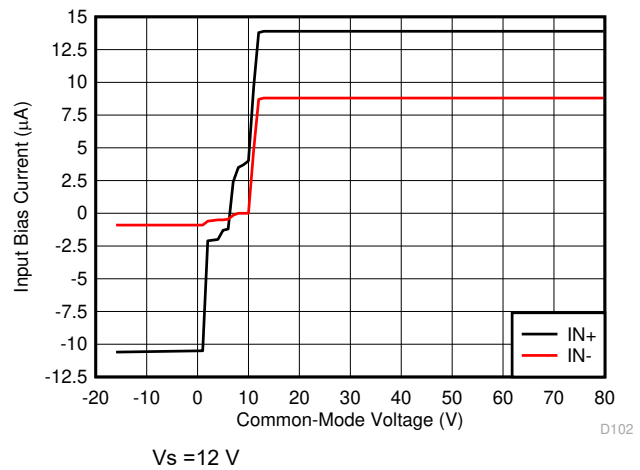

**6-10. Input Bias Current vs Common Mode Voltage**

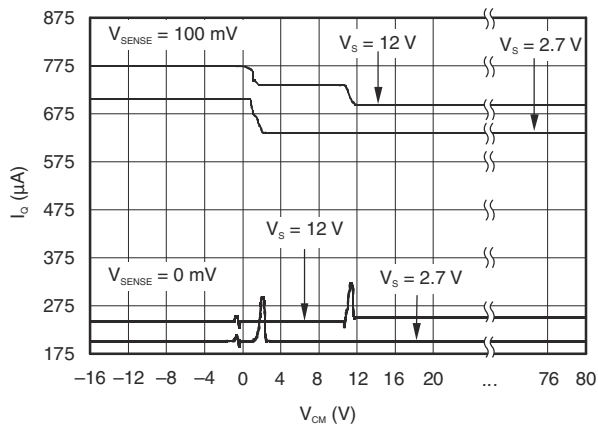

**6-11. Quiescent Current vs Common Mode Voltage**

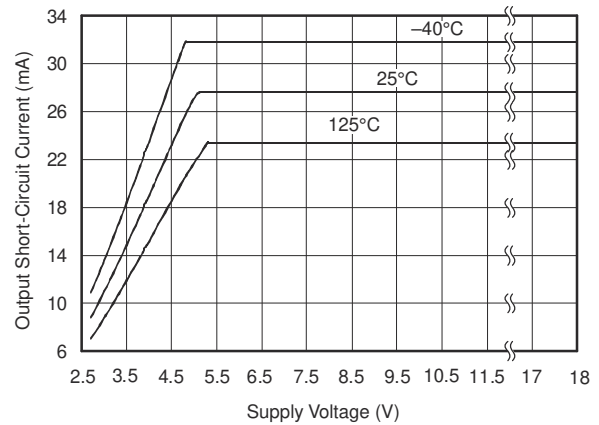

**6-12. Output Short Circuit Current vs Supply Voltage**



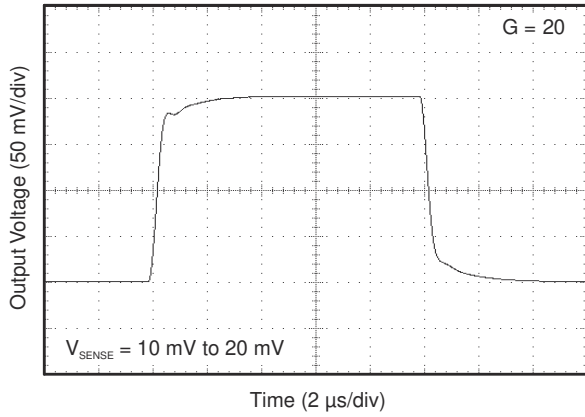

**6-13. Step Response**

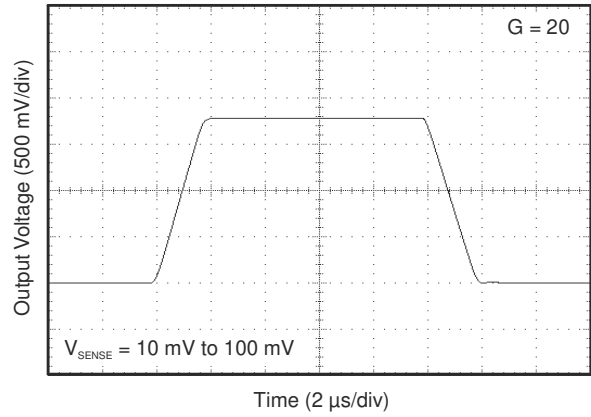

**6-14. Step Response**

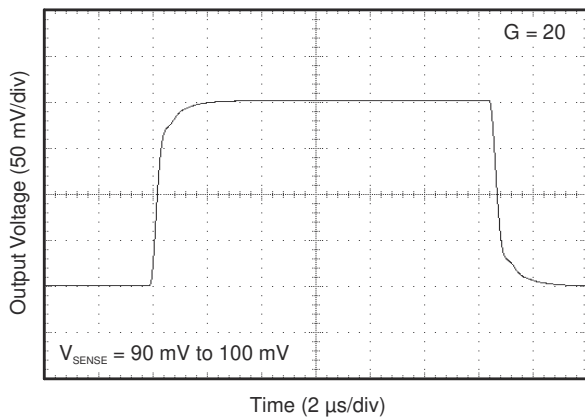

**6-15. Step Response**

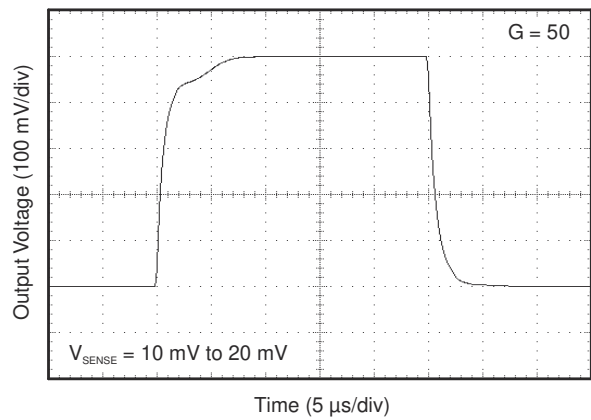

**6-16. Step Response**

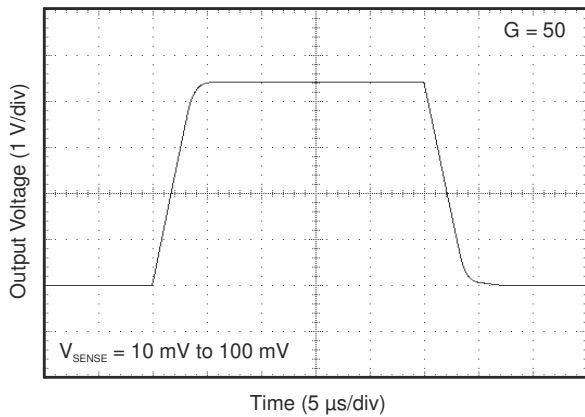

**6-17. Step Response**

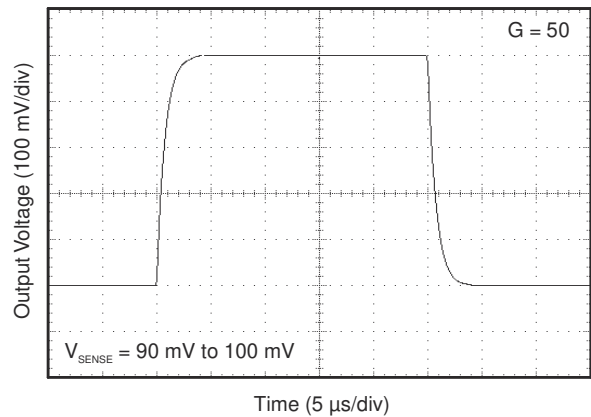

**6-18. Step Response**

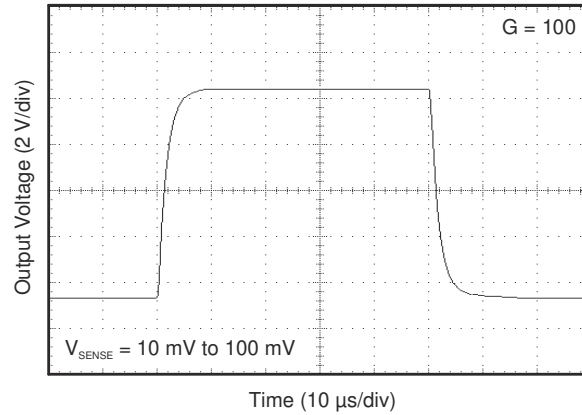

**6-19. Step Response**

## 7 Detailed Description

### 7.1 Overview

The INA193A–INA198A family of current shunt monitors with voltage output can sense drops across shunts at common mode voltages from –16 V to 80 V, independent of the INA19x supply voltage. They are available with three output voltage scales: 20 V/V, 50 V/V, and 100 V/V. The 500-kHz bandwidth simplifies use in current control loops. The INA193A–INA195A devices provide identical functions but alternative pin configurations to the INA196A–INA198A, respectively.

The INA193A–INA198A devices operate from a single 2.7-V to 18-V supply, drawing a maximum of 900  $\mu$ A of supply current. They are specified over the extended operating temperature range (–40°C to 125°C), and are offered in a space-saving SOT-23 package.

### 7.2 Functional Block Diagram

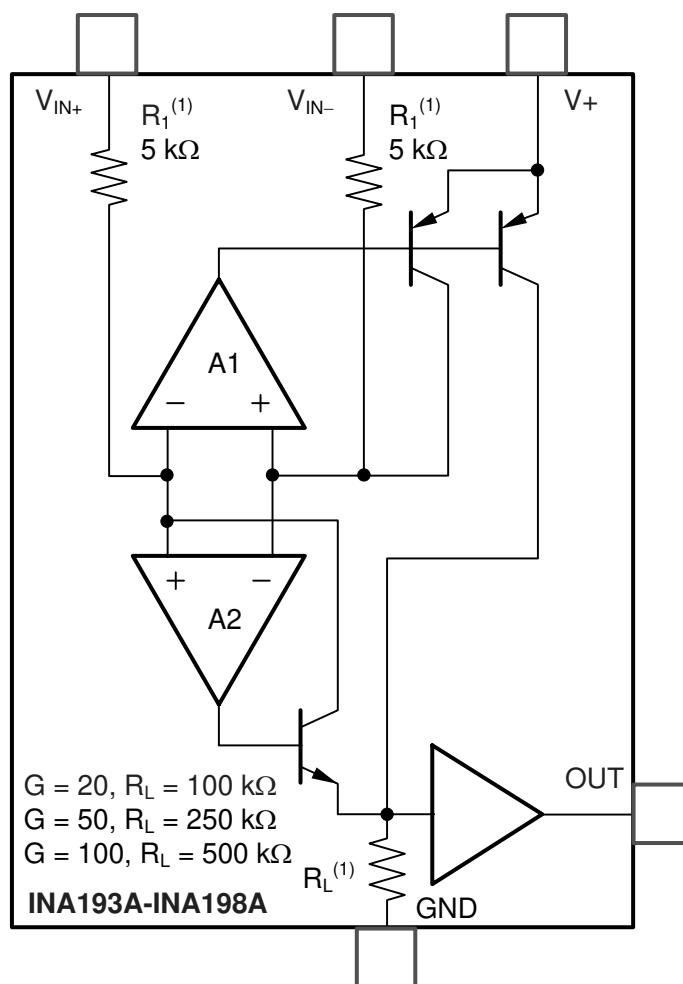

### 7.3 Feature Description

#### 7.3.1 Basic Connection

 **7-1** shows the basic connection of the INA19xA. The input pins,  $V_{IN+}$  and  $V_{IN-}$ , should be connected as closely as possible to the shunt resistor to minimize any resistance in series with the shunt resistance.

Power-supply bypass capacitors are required for stability. Applications with noisy or high-impedance power supplies may require additional decoupling capacitors to reject power-supply noise. Connect bypass capacitors close to the device pins.

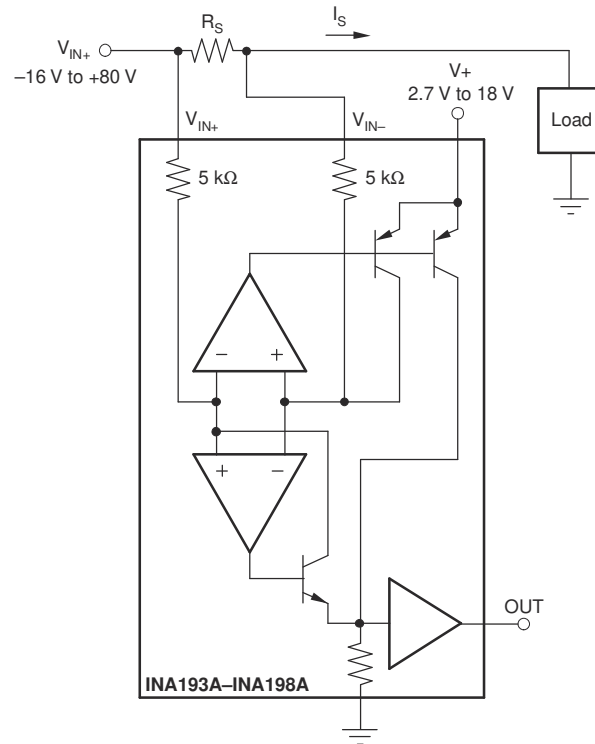

**7-1. INA19xA Basic Connections**

### 7.3.2 Selecting $R_S$

The value chosen for the shunt resistor,  $R_S$ , depends on the application and is a compromise between small-signal accuracy and maximum permissible voltage loss in the measurement line. High values of  $R_S$  provide better accuracy at lower currents by minimizing the effects of offset, while low values of  $R_S$  minimize voltage loss in the supply line. For most applications, best performance is attained with an  $R_S$  value that provides a full-scale shunt voltage range of 50 mV to 100 mV. Maximum input voltage for accurate measurements is 500 mV.

### 7.3.3 Inside the INA19xA

The INA19xA uses a new, unique, internal circuit topology that provides common mode range extending from –16 V to 80 V while operating from a single power supply. The common mode rejection in a classic instrumentation amplifier approach is limited by the requirement for accurate resistor matching. By converting the induced input voltage to a current, the INA19xA provides common mode rejection that is no longer a function of closely matched resistor values, providing the enhanced performance necessary for such a wide common mode range. A simplified diagram (see [7-1](#)) shows the basic circuit function. When the common mode voltage is positive, amplifier A2 is active.

The differential input voltage,  $V_{IN+} - V_{IN-}$  applied across  $R_S$ , is converted to a current through a 5-kΩ resistor. This current is converted back to a voltage through  $R_L$ , and then amplified by the output buffer amplifier. When the common mode voltage is negative, amplifier A1 is active. The differential input voltage,  $V_{IN+} - V_{IN-}$  applied across  $R_S$ , is converted to a current through a 5-kΩ resistor. This current is sourced from a precision current mirror whose output is directed into  $R_L$ , converting the signal back into a voltage and amplified by the output buffer amplifier. Patent-pending circuit architecture ensures smooth device operation, even during the transition period where both amplifiers A1 and A2 are active.

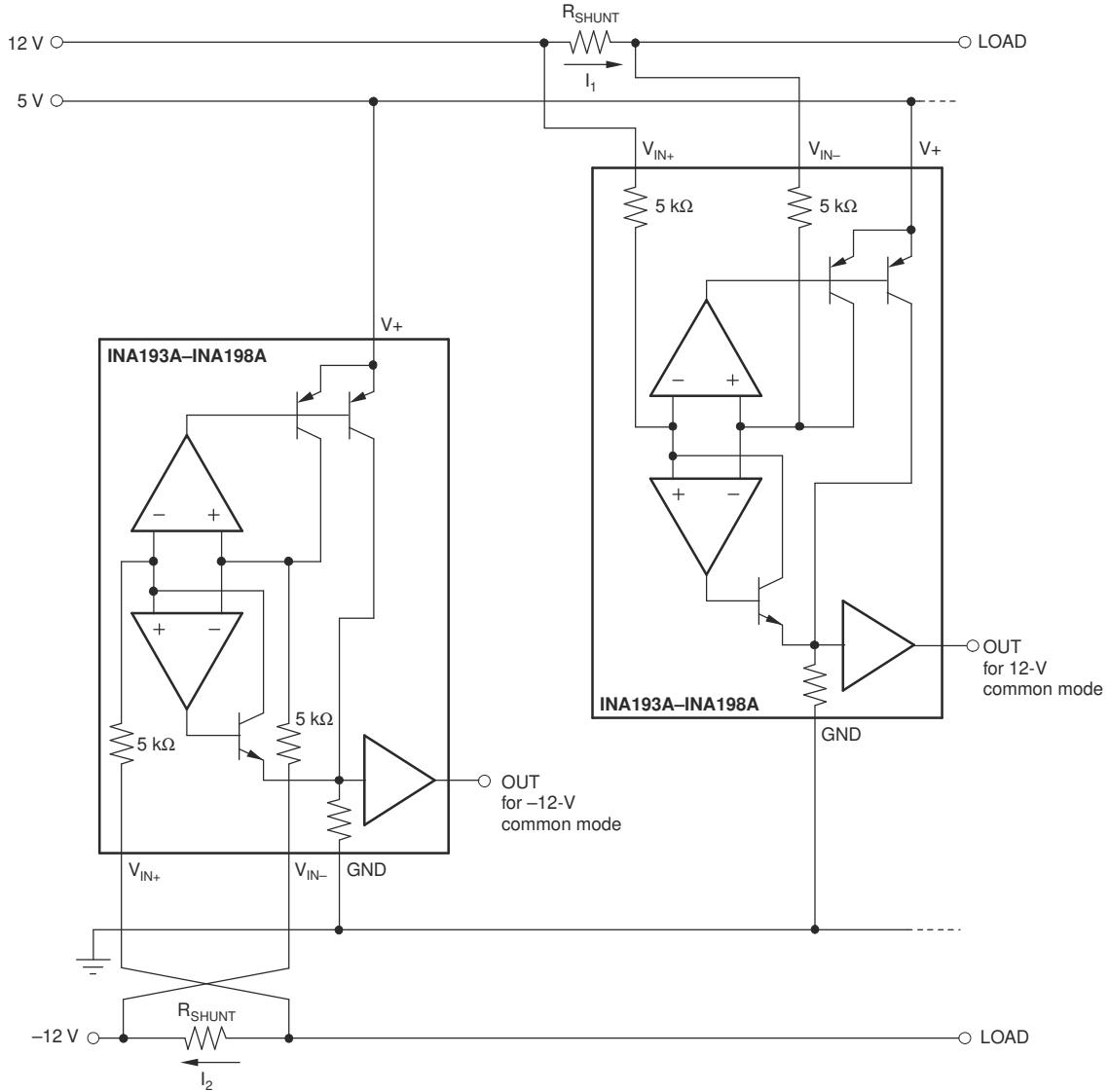

**图 7-2. Monitor Bipolar Output Power-Supply Current**

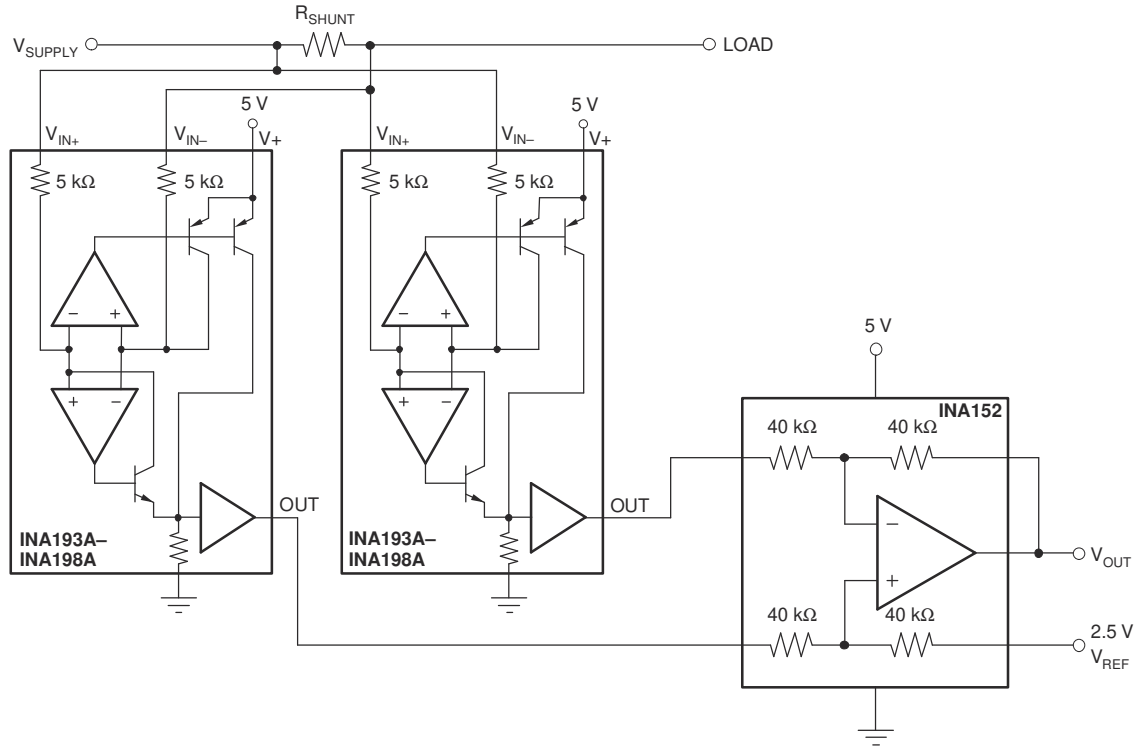

**7-3. Bidirectional Current Monitoring**

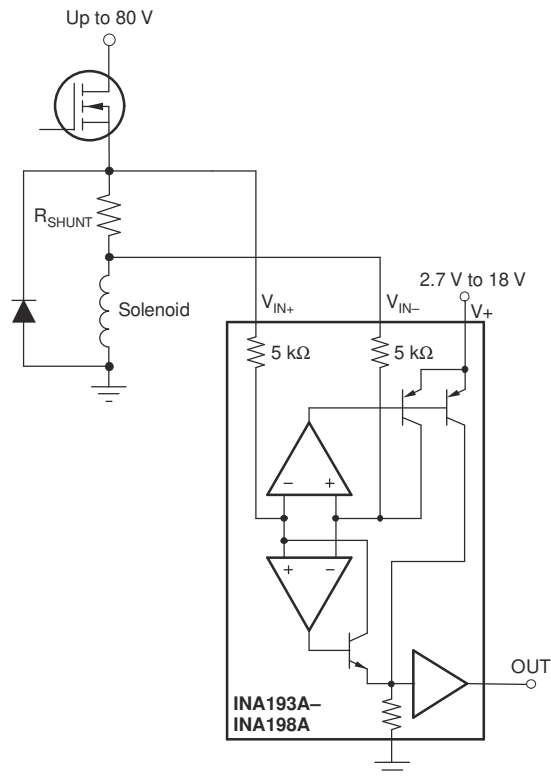

**7-4. Inductive Current Monitor Including Flyback**

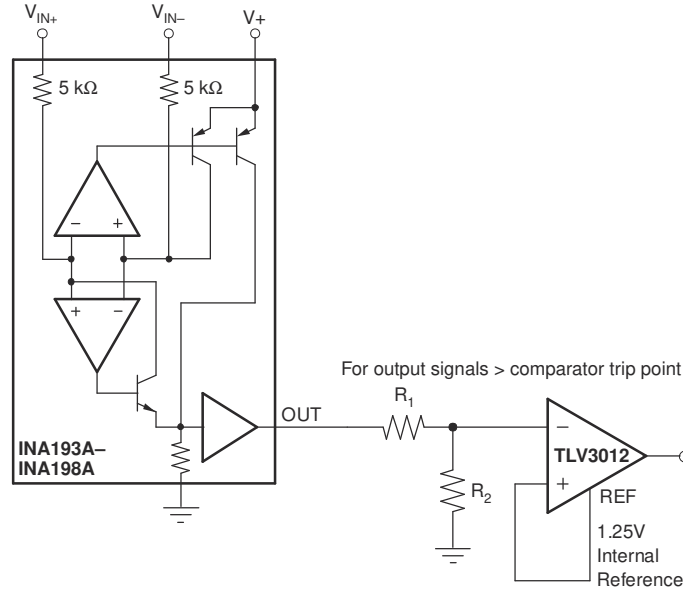

(a) INA19xA Output Adjusted by Voltage Divider

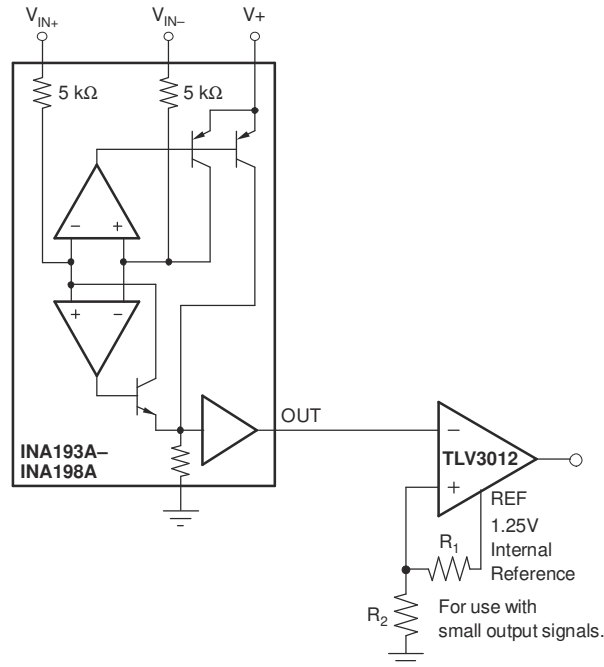

(b) Comparator Reference Voltage Adjusted by Voltage Divider

### 7-5. INA19xA With Comparator

#### 7.3.4 Power Supply

The input circuitry of the INA19xA can accurately measure beyond its power-supply voltage,  $V+$ . For example, the  $V+$  power supply can be 5 V, whereas the load power-supply voltage is up to 80 V. The output voltage range of the OUT terminal, however, is limited by the voltages on the power-supply pin.

## 7.4 Device Functional Modes

### 7.4.1 Input Filtering

An obvious and straightforward location for filtering is at the output of the INA19xA series; however, this location negates the advantage of the low output impedance of the internal buffer. The only other option for filtering is at the input pins of the INA19xA, which is complicated by the internal  $5\text{-k}\Omega \pm 30\%$  input impedance (see [7-6](#)). Using the lowest possible resistor values minimizes both the initial shift in gain and effects of tolerance. The effect on initial gain is given by:

$$\text{Gain Error \%} = 100 - \left( 100 \times \frac{5\text{ k}\Omega}{5\text{ k}\Omega + R_{\text{FILT}}} \right) \quad (1)$$

Total effect on gain error can be calculated by replacing the  $5\text{-k}\Omega$  term with  $5\text{ k}\Omega - 30\%$  (or  $3.5\text{ k}\Omega$ ) or  $5\text{ k}\Omega + 30\%$  (or  $6.5\text{ k}\Omega$ ). The tolerance extremes of  $R_{\text{FILT}}$  can also be inserted into the equation. If a pair of  $100\text{-}\Omega$   $1\%$  resistors are used on the inputs, the initial gain error is  $1.96\%$ . Worst-case tolerance conditions always occur at the lower excursion of the internal  $5\text{-k}\Omega$  resistor ( $3.5\text{ k}\Omega$ ), and the higher excursion of  $R_{\text{FILT}}$ ,  $3\%$  in this case.

The specified accuracy of the INA19xA must then be combined in addition to these tolerances. While this discussion treats accuracy worst-case conditions by combining the extremes of the resistor values, it is appropriate to use geometric mean or root sum square calculations to total the effects of accuracy variations.

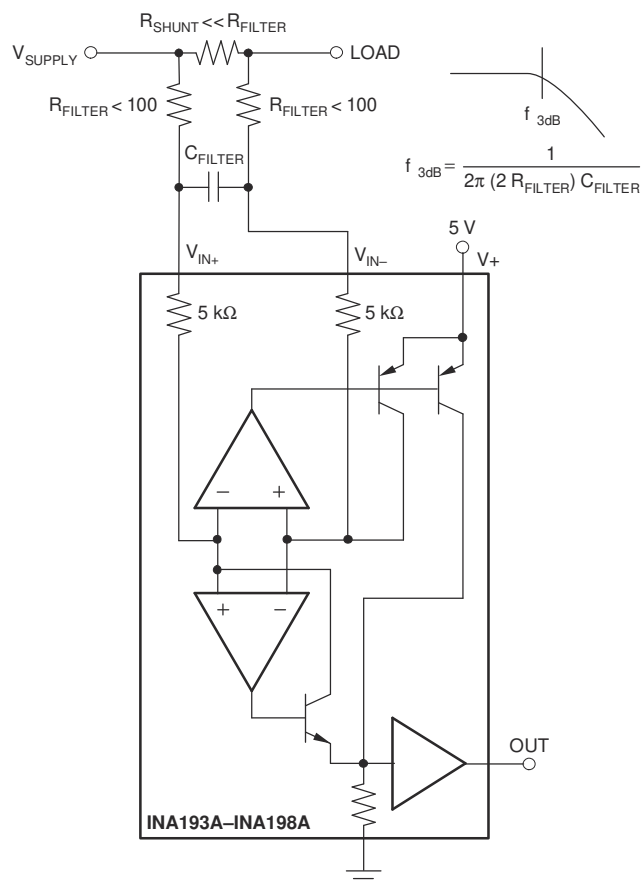

**图 7-6. Input Filter (Gain Error = 1.5% to -2.2%)**

### 7.4.2 Accuracy Variations as a Result Of $V_{\text{SENSE}}$ and Common Mode Voltage

The accuracy of the INA19xA-Q1 current shunt monitors is a function of two main variables:



$V_{SENSE}$  ( $V_{IN+} - V_{IN-}$ ) and common mode voltage,  $V_{CM}$ , relative to the supply voltage,  $V_S$ .  $V_{CM}$  is expressed as  $(V_{IN+} + V_{IN-})/2$ ; however, in practice,  $V_{CM}$  is seen as the voltage at  $V_{IN+}$  because the voltage drop across  $V_{SENSE}$  is usually small.

This section addresses the accuracy of these specific operating regions:

Normal Case 1:	$V_{SENSE} \geq 20 \text{ mV}, V_{CM} \geq V_S$
Normal Case 2:	$V_{SENSE} \geq 20 \text{ mV}, V_{CM} < V_S$
Low $V_{SENSE}$ Case 1:	$V_{SENSE} < 20 \text{ mV}, -16 \text{ V} \leq V_{CM} < 0$
Low $V_{SENSE}$ Case 2:	$V_{SENSE} < 20 \text{ mV}, 0 \text{ V} \leq V_{CM} \leq V_S$
Low $V_{SENSE}$ Case 3:	$V_{SENSE} < 20 \text{ mV}, V_S < V_{CM} \leq 80 \text{ V}$

#### 7.4.2.1 Normal Case 1: $V_{SENSE} \geq 20 \text{ mV}, V_{CM} \geq V_S$

This region of operation provides the highest accuracy. Here, the input offset voltage is characterized and measured using a two-step method. First, the gain is determined by (式 2).

$$G = \frac{V_{OUT1} - V_{OUT2}}{100 \text{ mV} - 20 \text{ mV}} \quad (2)$$

where

- $V_{OUT1}$  = Output voltage with  $V_{SENSE} = 100 \text{ mV}$
- $V_{OUT2}$  = Output voltage with  $V_{SENSE} = 20 \text{ mV}$

The offset voltage is then measured at  $V_{SENSE} = 100 \text{ mV}$  and referred to the input (RTI) of the current shunt monitor, as shown in (式 3).

$$V_{OSRTI} \text{ (Referred-To-Input)} = \left( \frac{V_{OUT1}}{G} \right) - 100 \text{ mV} \quad (3)$$

In [セクション 6.6](#), the *Output Error vs Common Mode Voltage* curve shows the highest accuracy for the this region of operation. In this plot,  $V_S = 12 \text{ V}$ ; for  $V_{CM} \geq 12 \text{ V}$ , the output error is at its minimum. This case is also used to create the  $V_{SENSE} \geq 20 \text{ mV}$  output specifications in the [Electrical Characteristics](#) table.

#### 7.4.2.2 Normal Case 2: $V_{SENSE} \geq 20 \text{ mV}, V_{CM} < V_S$

This region of operation has slightly less accuracy than Normal Case 1 as a result of the common mode operating area in which the part functions, as seen in [図 6-6](#). As noted, for this graph  $V_S = 12 \text{ V}$ ; for  $V_{CM} < 12 \text{ V}$ , the Output Error increases as  $V_{CM}$  becomes less than  $12 \text{ V}$ , with a typical maximum error of 0.005% at the most negative  $V_{CM} = -16 \text{ V}$ .

#### 7.4.2.3 Low $V_{SENSE}$ Case 1: $V_{SENSE} < 20 \text{ mV}, -16 \text{ V} \leq V_{CM} < 0$ ; and Low $V_{SENSE}$ Case 3: $V_{SENSE} < 20 \text{ mV}, V_S < V_{CM} \leq 80 \text{ V}$

Although the INA19xA-Q1 family of devices are not designed for accurate operation in either of these regions, some applications are exposed to these conditions; for example, when monitoring power supplies that are switched on and off while  $V_S$  is still applied to the INA19xA-Q1. It is important to know what the behavior of the devices will be in these regions.

As  $V_{SENSE}$  approaches  $0 \text{ mV}$ , in these  $V_{CM}$  regions, the device output accuracy degrades. A larger-than-normal offset can appear at the current shunt monitor output with a typical maximum value of  $V_{OUT} = 300 \text{ mV}$  for  $V_{SENSE} = 0 \text{ mV}$ . As  $V_{SENSE}$  approaches  $20 \text{ mV}$ ,  $V_{OUT}$  returns to the expected output value with accuracy as specified in [セクション 6.5](#). [図 7-7](#) illustrates this effect using the INA195A and INA198A (Gain = 100).

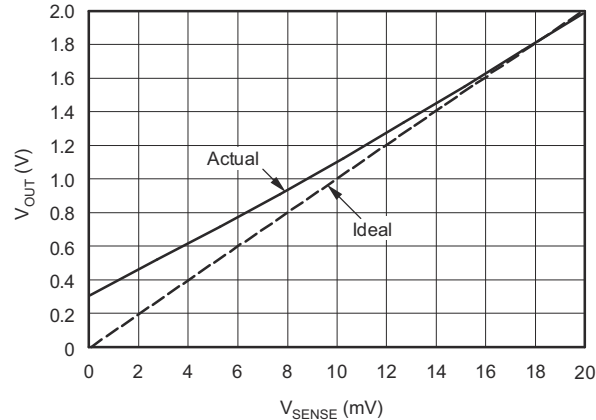
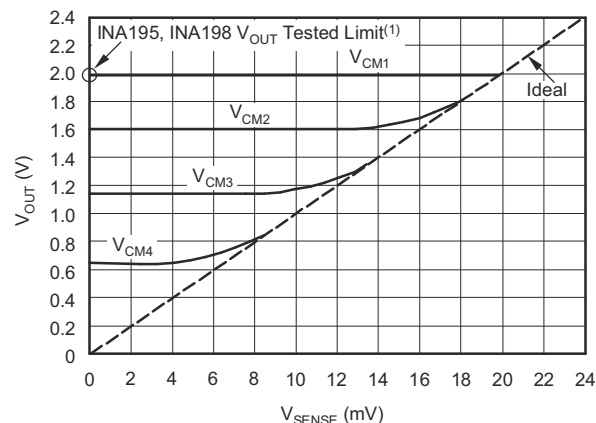

Figure 7-7. Example for Low  $V_{SENSE}$  Cases 1 and 3 (INA195A-Q1, INA198A-Q1: Gain = 100)

#### 7.4.2.4 Low $V_{SENSE}$ Case 2: $V_{SENSE} < 20\text{ mV}$ , $0\text{ V} \leq V_{CM} \leq V_S$

This region of operation is the least accurate for the INA19xA-Q1 family. To achieve the wide input common mode voltage range, these devices use two operational amplifier front ends in parallel. One operational amplifier front end operates in the positive input common mode voltage range, and the other in the negative input region. For this case, neither of these two internal amplifiers dominates and overall loop gain is very low. Within this region,  $V_{OUT}$  approaches voltages close to linear operation levels for Normal Case 2. This deviation from linear operation becomes greatest the closer  $V_{SENSE}$  approaches 0 V. Within this region, as  $V_{SENSE}$  approaches 20 mV, device operation is closer to that described by Normal Case 2. Figure 7-8 illustrates this behavior for the INA195A. The  $V_{OUT}$  maximum peak for this case is tested by maintaining a constant  $V_S$ , setting  $V_{SENSE} = 0\text{ mV}$  and sweeping  $V_{CM}$  from 0 V to  $V_S$ . The exact  $V_{CM}$  at which  $V_{OUT}$  peaks during this test varies from part to part, but the  $V_{OUT}$  maximum peak is tested to be less than the specified  $V_{OUT}$  tested limit.



- A. INA193, INA196  $V_{OUT}$  Tested Limit = 0.4 V
- INA194, INA197  $V_{OUT}$  Tested Limit = 1 V
- $V_{OUT}$  tested limit at  $V_{SENSE} = 0\text{ mV}$ ,  $0 \leq V_{CM1} \leq V_S$ .
- $V_{CM2}$ ,  $V_{CM3}$ , and  $V_{CM4}$  illustrate the variance from part to part of the  $V_{CM}$  that can cause maximum  $V_{OUT}$  with  $V_{SENSE} < 20\text{ mV}$ .

Figure 7-8. Example for Low  $V_{SENSE}$  Case 2 (INA195A, INA198A: Gain = 100)

#### 7.4.3 Shutdown

Because the INA19xA-Q1 consume a quiescent current less than 1 mA, they can be powered by either the output of logic gates or by transistor switches to supply power. Use a totem pole output buffer or gate that can provide sufficient drive along with 0.1  $\mu\text{F}$  bypass capacitor, preferably ceramic with good high frequency characteristics. This gate should have a supply voltage of 3 V or greater because the INA19xA-Q1 requires a minimum supply greater than 2.7 V. In addition to eliminating quiescent current, this gate also turns off the 10  $\mu\text{A}$  bias current present at each of the inputs. An example shutdown circuit is shown in Figure 7-9.

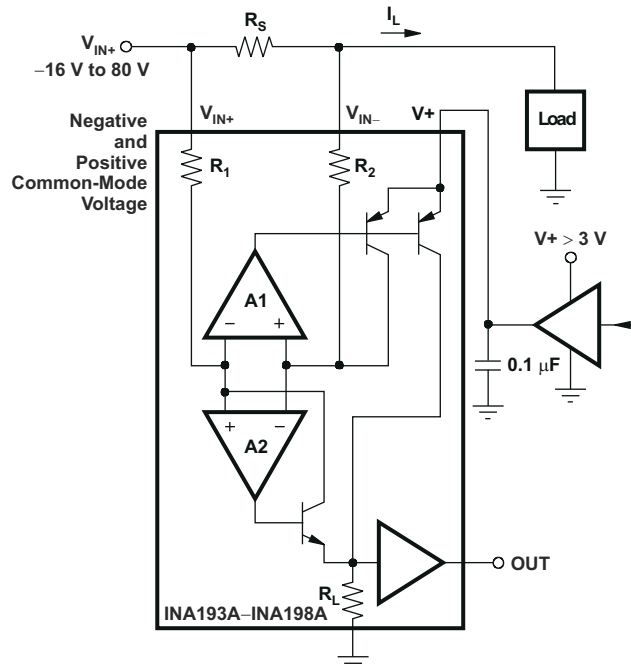

**7-9. INA19xA-Q1 Example Shutdown Circuit**

#### 7.4.4 Transient Protection

The  $-16\text{-V}$  to  $80\text{-V}$  common mode range of the INA19xA is ideal for withstanding automotive fault conditions ranging from  $12\text{-V}$  battery reversal up to  $80\text{-V}$  transients, because no additional protective components are needed up to those levels. In the event that the INA19xA is exposed to transients on the inputs in excess of its ratings, then external transient absorption with semiconductor transient absorbers (zeners or Transzorbs) are necessary. TI does not recommend using MOVs or VDRs except when they are used in addition to a semiconductor transient absorber. Select the transient absorber such that it never allows the INA19xA to be exposed to transients greater than  $80\text{ V}$  (that is, allow for transient absorber tolerance, as well as additional voltage due to transient absorber dynamic impedance). Despite the use of internal zener-type ESD protection, the INA19xA does not lend itself to using external resistors in series with the inputs because the internal gain resistors can vary up to  $\pm 30\%$ . (If gain accuracy is not important, then resistors can be added in series with the INA19xA inputs with two equal resistors on each input.)

#### 7.4.5 Output Voltage Range

The output of the INA19xA is accurate within the output voltage swing range set by the power supply pin,  $V+$ . This is best illustrated when using the INA195A or INA198A (which are both versions using a gain of 100), where a  $100\text{-mV}$  full-scale input from the shunt resistor requires an output voltage swing of  $10\text{ V}$ , and a power-supply voltage sufficient to achieve  $10\text{ V}$  on the output.

## 8 Application and Implementation

### 注

以下のアプリケーション情報は、TI の製品仕様に含まれるものではなく、TI ではその正確性または完全性を保証いたしません。個々の目的に対する製品の適合性については、お客様の責任で判断していただくこととなります。また、お客様は自身の設計実装を検証しテストすることで、システムの機能を確認する必要があります。

### 8.1 Application Information

The INA193A-INA198A devices measure the voltage developed across a current-sensing resistor when current passes through it. The ability to have shunt common mode voltages from  $-16\text{V}$  to  $80\text{V}$  drive and control the output signal with  $V_S$  offers multiple configurations, as discussed throughout this section.

### 8.2 Typical Application

The device is a unidirectional, current-sense amplifier capable of measuring currents through a resistive shunt with shunt common mode voltages from  $-16\text{V}$  to  $80\text{V}$ . Two devices can be configured for bidirectional monitoring and is common in applications that include charging and discharging operations where the current flow-through resistor can change directions.



図 8-1. Bidirectional Current Monitoring

#### 8.2.1 Design Requirements

$V_{\text{supply}}$  is set to  $12\text{V}$ ,  $V_{\text{ref}}$  at  $2.5\text{V}$  and a  $10\text{-m}\Omega$  shunt. The accuracy of the current will typically be less than  $0.5\%$  for current greater than  $\pm 2\text{A}$ . For current lower than  $\pm 2\text{A}$ , the accuracy will vary; use [セクション 7.4.2](#) for accuracy considerations.

#### 8.2.2 Detailed Design Procedure

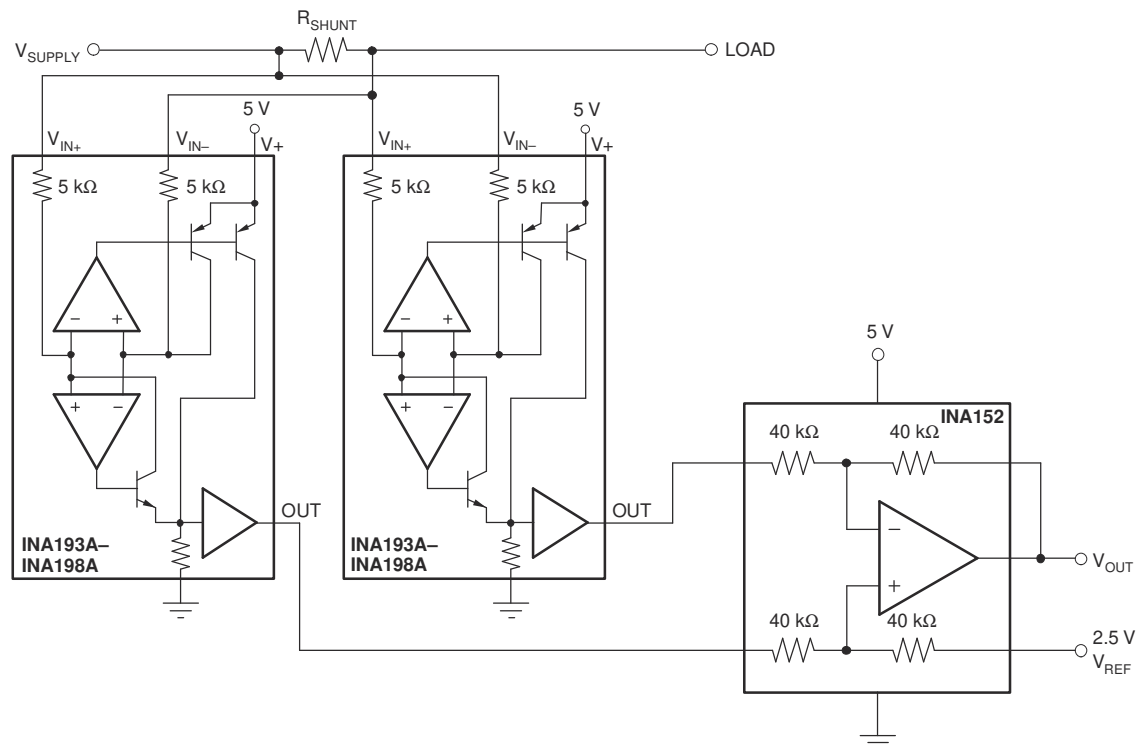
The ability to measure this current flowing in both directions is enabled by adding a unity gain amplifier with a  $V_{\text{REF}}$ , as shown in [図 8-1](#). The output then responds by increasing above  $V_{\text{REF}}$  for positive differential signals

(relative to the IN – pin) and responds by decreasing below VREF for negative differential signals. This reference voltage applied to the REF pin can be set anywhere from 0 V to V+. For bidirectional applications, VREF is typically set at mid-scale for equal signal range in both current directions. In some cases, however, VREF is set at a voltage other than mid-scale when the bidirectional current and corresponding output signal are not required to be symmetrical.

### 8.2.3 Application Curve

An example output response of a bidirectional configuration is shown in [Figure 8-2](#). With the REF pin connected to a reference voltage, 2.5 V in this case, the output voltage is biased upwards by this reference level. The output rises above the reference voltage for positive differential input signals and falls below the reference voltage for negative differential input signals.

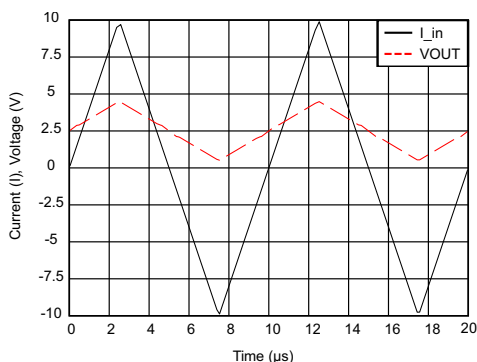

**Figure 8-2. Output Voltage vs Shunt Input Current**

## 9 Power Supply Recommendations

The input circuitry of the INA193A-INA198A devices can accurately measure beyond its power-supply voltage, V+. For example, the V+ power supply can be 5 V, whereas the load power-supply voltage is up to 80 V. The output voltage range of the OUT terminal, however, is limited by the voltages on the power-supply pin.

## 10 Layout

### 10.1 Layout Guidelines

#### 10.1.1 RFI/EMI

TI always recommends adhering to good layout practices. Keep traces short and, when possible, use a printed-circuit-board (PCB) ground plane with surface-mount components placed as close to the device pins as possible. Small ceramic capacitors placed directly across amplifier inputs can reduce RFI/EMI sensitivity. PCB layout should locate the amplifier as far away as possible from RFI sources. Sources can include other components in the same system as the amplifier itself, such as inductors (particularly switched inductors handling a lot of current and at high frequencies). RFI can generally be identified as a variation in offset voltage or dc signal levels with changes in the interfering RF signal. If the amplifier cannot be located away from sources of radiation, shielding may be needed. Twisting wire input leads makes them more resistant to RF fields. The difference in input pin location of the INA193A–INA195A versus the INA196A–INA198A may provide different EMI performance.

### 10.2 Layout Example

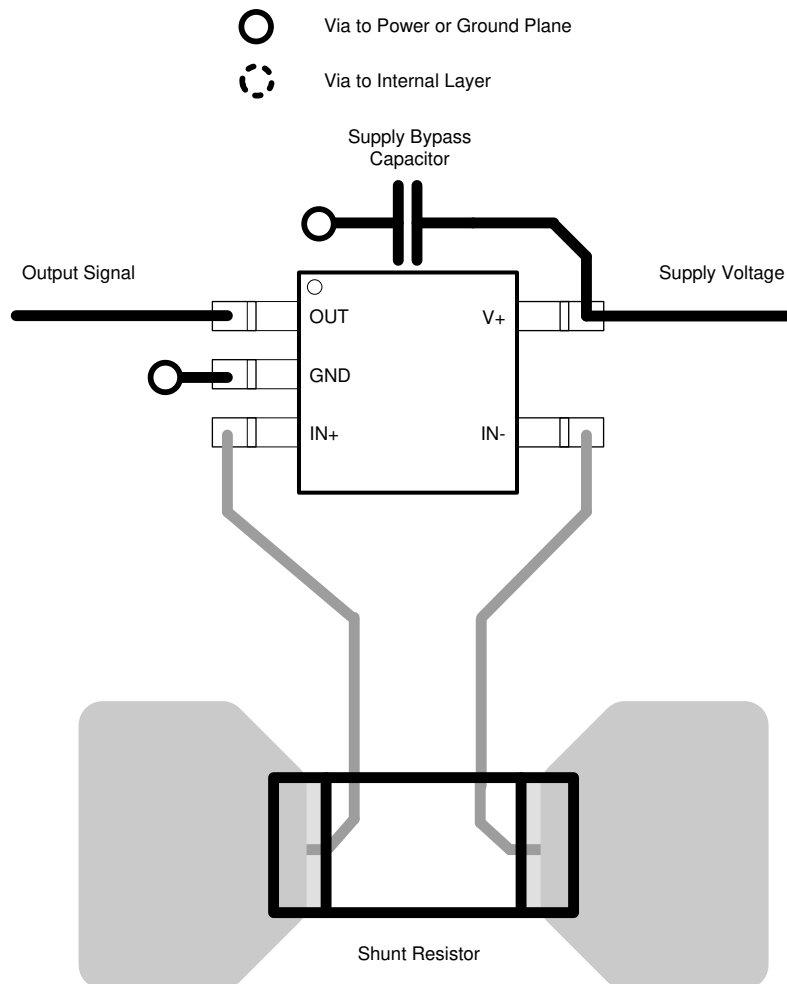

 **10-1. Recommended Layout**

## 11 Device and Documentation Support

### 11.1 ドキュメントの更新通知を受け取る方法

ドキュメントの更新についての通知を受け取るには、[ti.com](https://www.ti.com) のデバイス製品フォルダを開いてください。「更新の通知を受け取る」をクリックして登録すると、変更されたすべての製品情報に関するダイジェストを毎週受け取れます。変更の詳細については、修正されたドキュメントに含まれている改訂履歴をご覧ください。

### 11.2 サポート・リソース

**TI E2E™ サポート・フォーラム**は、エンジニアが検証済みの回答と設計に関するヒントをエキスパートから迅速かつ直接得ることができる場所です。既存の回答を検索したり、独自の質問をしたりすることで、設計に必要な支援を迅速に得ることができます。

リンクされているコンテンツは、該当する貢献者により、現状のまま提供されるものです。これらは TI の仕様を構成するものではなく、必ずしも TI の見解を反映したものではありません。TI の[使用条件](#)を参照してください。

### 11.3 Trademarks

TI E2E™ is a trademark of Texas Instruments.

すべての商標は、それぞれの所有者に帰属します。

### 11.4 静電気放電に関する注意事項



この IC は、ESD によって破損する可能性があります。テキサス・インスツルメンツは、IC を取り扱う際には常に適切な注意を払うことを推奨します。正しい ESD 対策をとらないと、デバイスを破損するおそれがあります。

ESD による破損は、わずかな性能低下からデバイスの完全な故障まで多岐にわたります。精密な IC の場合、パラメータがわずかに変化するだけで公表されている仕様から外れる可能性があるため、破損が発生しやすくなっています。

### 11.5 用語集

**TI 用語集** この用語集には、用語や略語の一覧および定義が記載されています。

## 12 Mechanical, Packaging, and Orderable Information

The following pages include mechanical, packaging, and orderable information. This information is the most current data available for the designated devices. This data is subject to change without notice and revision of this document. For browser-based versions of this data sheet, refer to the left-hand navigation.

**PACKAGING INFORMATION**

Orderable part number	Status (1)	Material type (2)	Package   Pins	Package qty   Carrier	RoHS (3)	Lead finish/ Ball material (4)	MSL rating/ Peak reflow (5)	Op temp (°C)	Part marking (6)
<a href="#">INA193AQDBVRQ1</a>	Active	Production	SOT-23 (DBV)   5	3000   LARGE T&R	Yes	NIPDAU	Level-2-260C-1 YEAR	-40 to 125	BOG
INA193AQDBVRQ1.A	Active	Production	SOT-23 (DBV)   5	3000   LARGE T&R	Yes	NIPDAU	Level-2-260C-1 YEAR	-40 to 125	BOG
INA193AQDBVRQ1G4.A	Active	Production	SOT-23 (DBV)   5	3000   LARGE T&R	Yes	NIPDAU	Level-2-260C-1 YEAR	-40 to 125	BOG
<a href="#">INA194AQDBVRQ1</a>	Active	Production	SOT-23 (DBV)   5	3000   LARGE T&R	Yes	NIPDAU	Level-2-260C-1 YEAR	-40 to 125	BOH
INA194AQDBVRQ1.A	Active	Production	SOT-23 (DBV)   5	3000   LARGE T&R	Yes	NIPDAU	Level-2-260C-1 YEAR	-40 to 125	BOH
INA194AQDBVRQ1G4.A	Active	Production	SOT-23 (DBV)   5	3000   LARGE T&R	Yes	NIPDAU	Level-2-260C-1 YEAR	-40 to 125	BOH
<a href="#">INA195AQDBVRQ1</a>	Active	Production	SOT-23 (DBV)   5	3000   LARGE T&R	Yes	NIPDAU	Level-2-260C-1 YEAR	-40 to 125	BOI
INA195AQDBVRQ1.A	Active	Production	SOT-23 (DBV)   5	3000   LARGE T&R	Yes	NIPDAU	Level-2-260C-1 YEAR	-40 to 125	BOI
<a href="#">INA196AQDBVRQ1</a>	Active	Production	SOT-23 (DBV)   5	3000   LARGE T&R	Yes	NIPDAU	Level-2-260C-1 YEAR	-40 to 125	BOJ
INA196AQDBVRQ1.A	Active	Production	SOT-23 (DBV)   5	3000   LARGE T&R	Yes	NIPDAU	Level-2-260C-1 YEAR	-40 to 125	BOJ
<a href="#">INA197AQDBVRQ1</a>	Active	Production	SOT-23 (DBV)   5	3000   LARGE T&R	Yes	NIPDAU	Level-2-260C-1 YEAR	-40 to 125	BOK
INA197AQDBVRQ1.A	Active	Production	SOT-23 (DBV)   5	3000   LARGE T&R	Yes	NIPDAU	Level-2-260C-1 YEAR	-40 to 125	BOK
<a href="#">INA198AQDBVRQ1</a>	Active	Production	SOT-23 (DBV)   5	3000   LARGE T&R	Yes	NIPDAU	Level-2-260C-1 YEAR	-40 to 125	BOL
INA198AQDBVRQ1.A	Active	Production	SOT-23 (DBV)   5	3000   LARGE T&R	Yes	NIPDAU	Level-2-260C-1 YEAR	-40 to 125	BOL

(1) **Status:** For more details on status, see our [product life cycle](#).

(2) **Material type:** When designated, preproduction parts are prototypes/experimental devices, and are not yet approved or released for full production. Testing and final process, including without limitation quality assurance, reliability performance testing, and/or process qualification, may not yet be complete, and this item is subject to further changes or possible discontinuation. If available for ordering, purchases will be subject to an additional waiver at checkout, and are intended for early internal evaluation purposes only. These items are sold without warranties of any kind.

(3) **RoHS values:** Yes, No, RoHS Exempt. See the [TI RoHS Statement](#) for additional information and value definition.

(4) **Lead finish/Ball material:** Parts may have multiple material finish options. Finish options are separated by a vertical ruled line. Lead finish/Ball material values may wrap to two lines if the finish value exceeds the maximum column width.

(5) **MSL rating/Peak reflow:** The moisture sensitivity level ratings and peak solder (reflow) temperatures. In the event that a part has multiple moisture sensitivity ratings, only the lowest level per JEDEC standards is shown. Refer to the shipping label for the actual reflow temperature that will be used to mount the part to the printed circuit board.

(6) **Part marking:** There may be an additional marking, which relates to the logo, the lot trace code information, or the environmental category of the part.



Multiple part markings will be inside parentheses. Only one part marking contained in parentheses and separated by a "~" will appear on a part. If a line is indented then it is a continuation of the previous line and the two combined represent the entire part marking for that device.

**Important Information and Disclaimer:** The information provided on this page represents TI's knowledge and belief as of the date that it is provided. TI bases its knowledge and belief on information provided by third parties, and makes no representation or warranty as to the accuracy of such information. Efforts are underway to better integrate information from third parties. TI has taken and continues to take reasonable steps to provide representative and accurate information but may not have conducted destructive testing or chemical analysis on incoming materials and chemicals. TI and TI suppliers consider certain information to be proprietary, and thus CAS numbers and other limited information may not be available for release.

In no event shall TI's liability arising out of such information exceed the total purchase price of the TI part(s) at issue in this document sold by TI to Customer on an annual basis.

**OTHER QUALIFIED VERSIONS OF INA193A-Q1 :**

- Enhanced Product : [INA193A-EP](#)

NOTE: Qualified Version Definitions:

- Enhanced Product - Supports Defense, Aerospace and Medical Applications

**TAPE AND REEL INFORMATION**

**QUADRANT ASSIGNMENTS FOR PIN 1 ORIENTATION IN TAPE**

\*All dimensions are nominal

Device	Package Type	Package Drawing	Pins	SPQ	Reel Diameter (mm)	Reel Width W1 (mm)	A0 (mm)	B0 (mm)	K0 (mm)	P1 (mm)	W (mm)	Pin1 Quadrant
INA193AQDBVRQ1	SOT-23	DBV	5	3000	178.0	9.0	3.3	3.2	1.4	4.0	8.0	Q3
INA194AQDBVRQ1	SOT-23	DBV	5	3000	178.0	9.0	3.3	3.2	1.4	4.0	8.0	Q3
INA195AQDBVRQ1	SOT-23	DBV	5	3000	178.0	9.0	3.3	3.2	1.4	4.0	8.0	Q3
INA196AQDBVRQ1	SOT-23	DBV	5	3000	178.0	9.0	3.3	3.2	1.4	4.0	8.0	Q3
INA197AQDBVRQ1	SOT-23	DBV	5	3000	178.0	9.0	3.3	3.2	1.4	4.0	8.0	Q3
INA198AQDBVRQ1	SOT-23	DBV	5	3000	178.0	9.0	3.3	3.2	1.4	4.0	8.0	Q3

**TAPE AND REEL BOX DIMENSIONS**

\*All dimensions are nominal

Device	Package Type	Package Drawing	Pins	SPQ	Length (mm)	Width (mm)	Height (mm)
INA193AQDBVRQ1	SOT-23	DBV	5	3000	190.0	190.0	30.0
INA194AQDBVRQ1	SOT-23	DBV	5	3000	190.0	190.0	30.0
INA195AQDBVRQ1	SOT-23	DBV	5	3000	190.0	190.0	30.0
INA196AQDBVRQ1	SOT-23	DBV	5	3000	190.0	190.0	30.0
INA197AQDBVRQ1	SOT-23	DBV	5	3000	190.0	190.0	30.0
INA198AQDBVRQ1	SOT-23	DBV	5	3000	190.0	190.0	30.0



# EXAMPLE BOARD LAYOUT

DBV0005A

SOT-23 - 1.45 mm max height

SMALL OUTLINE TRANSISTOR



LAND PATTERN EXAMPLE  
EXPOSED METAL SHOWN  
SCALE:15X



SOLDER MASK DETAILS

4214839/K 08/2024

NOTES: (continued)

- 6. Publication IPC-7351 may have alternate designs.
- 7. Solder mask tolerances between and around signal pads can vary based on board fabrication site.

# EXAMPLE STENCIL DESIGN

DBV0005A

SOT-23 - 1.45 mm max height

SMALL OUTLINE TRANSISTOR



SOLDER PASTE EXAMPLE  
BASED ON 0.125 mm THICK STENCIL  
SCALE:15X

4214839/K 08/2024

NOTES: (continued)

8. Laser cutting apertures with trapezoidal walls and rounded corners may offer better paste release. IPC-7525 may have alternate design recommendations.
9. Board assembly site may have different recommendations for stencil design.

## 重要なお知らせと免責事項

テキサス・インスツルメンツは、技術データと信頼性データ(データシートを含みます)、設計リソース(リファレンス デザインを含みます)、アプリケーションや設計に関する各種アドバイス、Web ツール、安全性情報、その他のリソースを、欠陥が存在する可能性のある「現状のまま」提供しており、商品性および特定目的に対する適合性の黙示保証、第三者の知的財産権の非侵害保証を含むいかなる保証も、明示的または黙示的にかかわらず拒否します。

これらのリソースは、テキサス・インスツルメンツ製品を使用する設計の経験を積んだ開発者への提供を意図したものです。(1) お客様のアプリケーションに適したテキサス・インスツルメンツ製品の選定、(2) お客様のアプリケーションの設計、検証、試験、(3) お客様のアプリケーションに該当する各種規格や、その他のあらゆる安全性、セキュリティ、規制、または他の要件への確実な適合に関する責任を、お客様のみが単独で負うものとし、ます。

上記の各種リソースは、予告なく変更される可能性があります。これらのリソースは、リソースで説明されているテキサス・インスツルメンツ製品を使用するアプリケーションの開発の目的でのみ、テキサス・インスツルメンツはその使用をお客様に許諾します。これらのリソースに関して、他の目的で複製することや掲載することは禁止されています。テキサス・インスツルメンツや第三者の知的財産権のライセンスが付与されている訳ではありません。お客様は、これらのリソースを自身で使用した結果発生するあらゆる申し立て、損害、費用、損失、責任について、テキサス・インスツルメンツおよびその代理人を完全に補償するものとし、テキサス・インスツルメンツは一切の責任を拒否します。

テキサス・インスツルメンツの製品は、[テキサス・インスツルメンツの販売条件](#)、または [ti.com](https://www.ti.com) やかかるテキサス・インスツルメンツ製品の関連資料などのいずれかを通じて提供する適用可能な条項の下で提供されています。テキサス・インスツルメンツがこれらのリソースを提供することは、適用されるテキサス・インスツルメンツの保証または他の保証の放棄の拡大や変更を意味するものではありません。

お客様がいかなる追加条項または代替条項を提案した場合でも、テキサス・インスツルメンツはそれらに異議を唱え、拒否します。

郵送先住所：Texas Instruments, Post Office Box 655303, Dallas, Texas 75265  
Copyright © 2025, Texas Instruments Incorporated