

DS160PR822 PCIe 4.0 16Gbps 8 チャンネル・リニア・リドライバ、4 個の 2x2 クロスポイント搭載

1 特長

- 8 チャンネル・リニア・イコライザで、最大 16Gbps の PCIe 4.0 をサポート
- プロトコルに依存しないリニア・リドライバで、UPI、DisplayPort、SAS、SATA、XFI を含む多くの高速インターフェイスをサポート
- 4 つの 2x2 クロスポイント多重化機能を提供
- 最高 42dB の PCIe 4.0 チャンネルを処理するイコライゼーション
- CTLE (連続時間リニア・イコライザ) は 8GHz 時に最大 18dB の向上を実現
- 非常に短いレイテンシ: 90ps
- 小さい付加ランダム・ジッタ (PRBS データ): 70fs
- 3.3V 単電源
- 低消費電力: チャンネルあたり 107mW (動作時)
- ヒートシンク不要
- ピンストラップ、SMBus/I²C または EEPROM プログラミング
- PCIe 用途での自動レシーバ検出
- PCIe リンク・トレーニングのシームレスなサポート
- 1 つまたは複数の DS160PR822 により、x2、x4、x8、x16 PCIe バス幅をサポート
- 40°C~85°C の産業用温度範囲
- 5.5mm × 10mm、64 ピン WQFN パッケージ

2 アプリケーション

- ラック・サーバー
- マイクロサーバー / タワー・サーバー
- 高性能コンピューティング
- ハードウェア・アクセラレータ
- ネットワーク接続ストレージ (NAS)
- ストレージ・エリア・ネットワーク (SAN) とホスト・バス・アダプタ (HBA) カード
- ネットワーク・インターフェイス・カード (NIC)
- デスクトップ PC / マザーボード

3 概要

DS160PR822 は、8 チャンネルの低消費電力高性能リニア・リドライバで、最大 16Gbps の PCIe 4.0 および Ultra Path Interface (UPI) 2.0 をサポートするように設計されています。このデバイスは、プロトコルに依存しないリニア・リドライバであり、多くの差動インターフェイスで動作できます。

DS160PR822 レシーバは、連続時間リニア・イコライザ (CTLE) を搭載し、高周波数での昇圧を実現しています。イコライザは、相互接続媒体 (例: PCB 配線、ケーブル) に起因する符号間干渉 (ISI) によって完全に閉じた入力アイ・パターンを開くことができます。リニア・リドライバとパッシブ・チャンネル全体は、最良の送信 / 受信イコライゼーション設定を実現するためにリンク・トレーニングされており、最良の電氣的リンクと可能な限り最小のレイテンシを実現します。チャンネル間クロストークが小さく、付加ジッタが小さく、反射損失特性が非常に優れた本デバイスは、リンク内でほとんど受動素子のように振舞います。このデバイスは、内部リニア電圧レギュレータを備えており、高速データ・パス用にクリーンな電源を供給し、基板上の電源ノイズへの高い耐性を実現します。

DS160PR822 は、量産時に高速テストを実施しており、信頼性の高い大量生産に対応しています。また、このデバイスは AC および DC ゲインの変動が小さいため、大容量プラットフォームを展開する際の一貫したイコライゼーションにも対応しています。

製品情報⁽¹⁾

部品番号	パッケージ	本体サイズ (公称)
DS160PR822	WQFN (64)	5.5mm × 10.00mm

- (1) 利用可能なすべてのパッケージについては、このデータシートの末尾にある注文情報を参照してください。



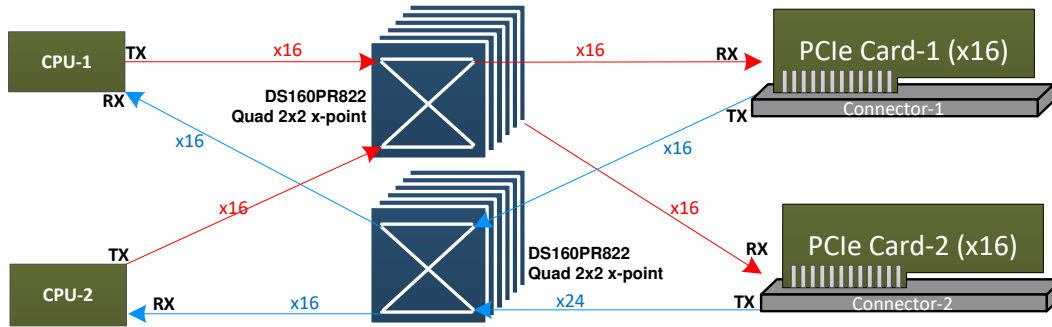

代表的なアプリケーション

Table of Contents

1 特長	1	7.2 Functional Block Diagram.....	18
2 アプリケーション	1	7.3 Feature Description.....	18
3 概要	1	7.4 Device Functional Modes.....	20
4 Revision History	3	7.5 Programming.....	21
5 Pin Configuration and Functions	4	8 Application and Implementation	23
Pin Functions.....	5	8.1 Application Information.....	23
6 Specifications	8	8.2 Typical Applications.....	23
6.1 Absolute Maximum Ratings	8	9 Power Supply Recommendations	27
6.2 ESD Ratings	8	10 Layout	28
6.3 Recommended Operating Conditions	8	10.1 Layout Guidelines.....	28
6.4 Thermal Information	9	10.2 Layout Example.....	29
6.5 DC Electrical Characteristics	9	11 Device and Documentation Support	30
6.6 High Speed Electrical Characteristics	10	11.1 Receiving Notification of Documentation Updates..	30
6.7 SMBUS/I2C Timing Characteristics	11	11.2 Community Resources.....	30
6.8 Typical Characteristics.....	13	11.3 Trademarks.....	30
7 Detailed Description	17	12 Mechanical, Packaging, and Orderable Information	30
7.1 Overview.....	17		

4 Revision History

資料番号末尾の英字は改訂を表しています。その改訂履歴は英語版に準じています。

DATE	REVISION	NOTES
December 2020	*	Initial release

5 Pin Configuration and Functions

5-1. NJX Package 64-Pin WQFN Top View

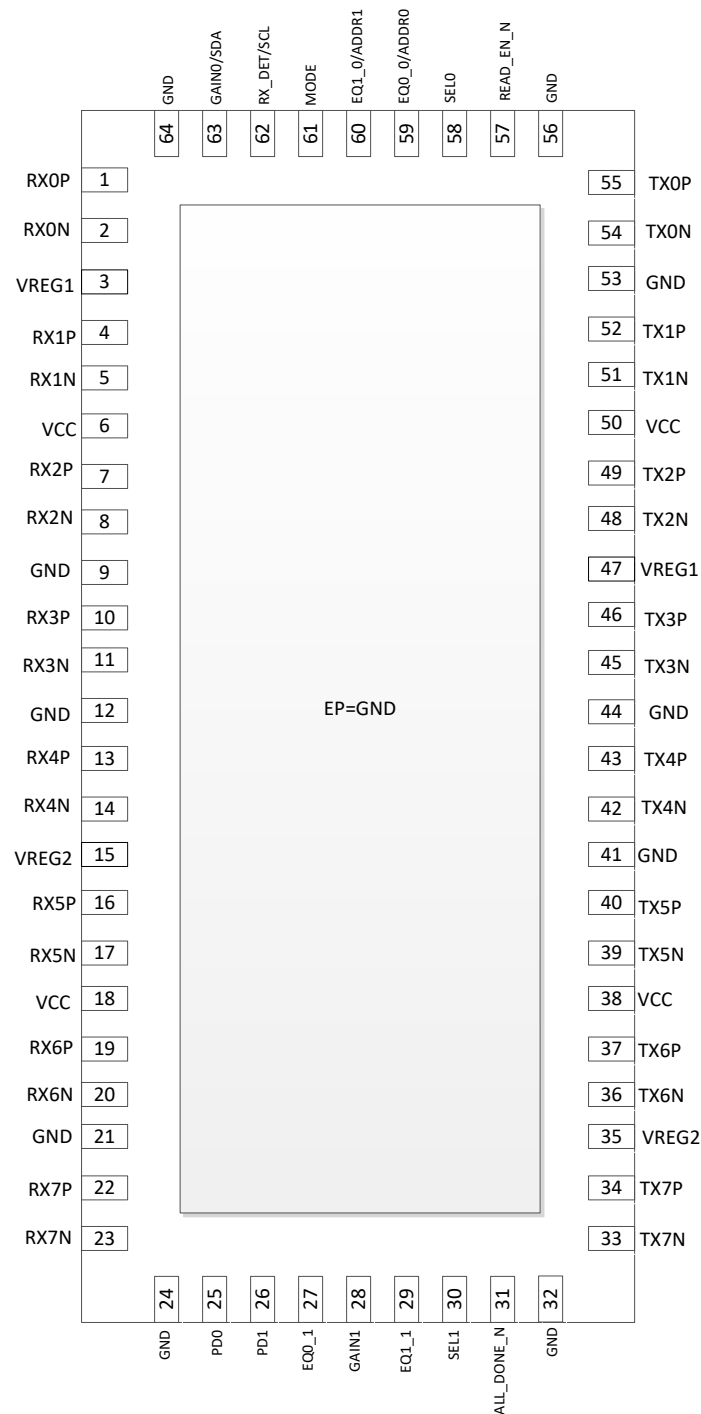

Pin Functions

PIN		I/O, TYPE	DESCRIPTION
NAME	NO.		
ALL_DONE_N	31	O, 3.3 V open drain	In SMBus/I²C Master Mode : Indicates the completion of a valid EEPROM register load operation. External pullup resistor such as 4.7 kΩ required for operation. High: External EEPROM load failed or incomplete Low: External EEPROM load successful and complete In SMBus/I²C slave/Pin Mode : This output is High-Z. The pin can be left floating.
MODE	61	I, 4-level	Sets device control configuration modes. 4-level IO pin as defined in 表 7-1 . The pin can be exercised at device power up or in normal operation mode. L0: Pin Mode – device control configuration is done solely by strap pins. L1: SMBus/I²C Master Mode - device control configuration is read from external EEPROM. When the device has finished reading from the EEPROM successfully, it will drive the ALL_DONE_N pin LOW. SMBus/I ² C slave operation is available in this mode before, during or after EEPROM reading. Note during EEPROM reading if the external SMBus/I ² C master wants to access the device registers it must support arbitration. L2: SMBus/I²C Slave Mode – device control configuration is done by an external controller with SMBus/I ² C master. L3 (Float): RESERVED – TI internal test mode.
EQ0_0 / ADDR0	59	I, 4-level	In Pin Mode : Sets receiver linear equalization (CTLE) for channels 0-3 according to 表 7-3 . These pins are sampled at device power-up only. In SMBus/I²C Mode : Sets SMBus / I ² C slave address according to 表 7-4 . These pins are sampled at device power-up only.
EQ1_0 / ADDR1	60	I, 4-level	
EQ0_1	27	I, 4-level	Sets receiver linear equalization (CTLE) for channels 4-7 according to 表 7-3 in Pin mode. The pin is sampled at device power-up only.
EQ1_1	29	I, 4-level	Sets receiver linear equalization (CTLE) for channels 4-7 according to 表 7-3 in Pin mode. The pin is sampled at device power-up only.
GAIN0 / SDA	63	I, 4-level / I/O, 3.3 V LVC MOS, open drain	In Pin Mode : Flat gain (DC and AC) from the input to the output of the device for channels 0-3. The pin is sampled at device power-up only. In SMBus/I²C Mode : 3.3 V SMBus/I ² C data. External 1 kΩ to 5 kΩ pullup resistor is required as per SMBus / I ² C interface standard.
GAIN1	28	I, 4-level	Flat gain (DC and AC) from the input to the output of the device for channels 4-7 in Pin mode. The pin is sampled at device power-up only.
GND	EP, 9, 12, 21, 24, 32, 41, 44, 53, 56, 64	P	Ground reference for the device. EP: the Exposed Pad at the bottom of the QFN package. It is used as the GND return for the device. The EP should be connected to ground plane(s) through low resistance path. A via array provides a low impedance path to GND. The EP also improves thermal dissipation.
PD0	25	I, 3.3 V LVC MOS	2-level logic controlling the operating state of the redriver. Active in all device control modes. The pin has internal 1-MΩ weak pulldown resistor. High: Power down for channels 0-3 Low: Power up, normal operation for channels 0-3
PD1	26	I, 3.3 V LVC MOS	2-level logic controlling the operating state of the redriver. Active in all device control modes. The pin has internal 1-MΩ weak pulldown resistor. High: Power down for channels 4-7 Low: Power up, normal operation for channels 4-7
READ_EN_N	57	I, 3.3 V LVC MOS	In SMBus/I²C Master Mode : After device power up, when the pin is low, it initiates the SMBus / I ² C master mode EEPROM read function. Once EEPROM read is complete (indicated by assertion of ALL_DONE_N low), this pin can be held low for normal device operation. During the EEPROM load process the device's signal path is disabled. In SMBus/I²C Slave and Pin Modes : In these modes the pin is not used. The pin can be left floating. The pin has internal 1-MΩ weak pulldown resistor.

PIN		I/O, TYPE	DESCRIPTION
NAME	NO.		
SEL0	58	I, 3.3 V LVCMOS	The pin selects the mux path for channels 0-3. L: straight data path - RX[0/1/2/3][P/N] connected to TX[0/1/2/3][P/N] through the redriver. H: cross data path - RX[0/1/2/3][P/N] connected to TX[1/0/3/2][P/N] through the redriver Active in all device control modes. 59 kΩ internal pull-down.
SEL1	30	I, 3.3 V LVCMOS	The pin selects the mux path for channels 4-7. L: straight data path - RX[4/5/6/7][P/N] connected to TX[4/5/6/7][P/N] through the redriver. H: cross data path - RX[4/5/6/7][P/N] connected to TX[5/4/7/6][P/N] through the redriver Active in all device control modes. 59 kΩ internal pull-down.
RX_DET / SCL	62	I, 4-level / I/O, 3.3 V LVCMOS, open drain	In Pin Mode : Sets receiver detect state machine options according to 表 7-2. The pin is sampled at device power-up only. In SMBus/I²C Mode : 3.3V SMBus/I ² C clock. External 1 kΩ to 5 kΩ pullup resistor is required as per SMBus / I ² C interface standard.
RX0N	2	I	Inverting differential inputs to the equalizer. Integrated 50 Ω termination resistor from the pin to internal CM bias voltage. Channel 0.
RX0P	1	I	Noninverting differential inputs to the equalizer. Integrated 50 Ω termination resistor from the pin to internal CM bias voltage. Channel 0.
RX1N	5	I	Inverting differential inputs to the equalizer. Integrated 50 Ω termination resistor from the pin to internal CM bias voltage. Channel 1.
RX1P	4	I	Noninverting differential inputs to the equalizer. Integrated 50 Ω termination resistor from the pin to internal CM bias voltage. Channel 1.
RX2N	8	I	Inverting differential inputs to the equalizer. Integrated 50 Ω termination resistor from the pin to internal CM bias voltage. Channel 2.
RX2P	7	I	Noninverting differential inputs to the equalizer. Integrated 50 Ω termination resistor from the pin to internal CM bias voltage. Channel 2.
RX3N	11	I	Inverting differential inputs to the equalizer. Integrated 50 Ω termination resistor from the pin to internal CM bias voltage. Channel 3.
RX3P	10	I	Noninverting differential inputs to the equalizer. Integrated 50 Ω termination resistor from the pin to internal CM bias voltage. Channel 3.
RX4N	14	I	Inverting differential inputs to the equalizer. Integrated 50 Ω termination resistor from the pin to internal CM bias voltage. Channel 4.
RX4P	13	I	Noninverting differential inputs to the equalizer. Integrated 50 Ω termination resistor from the pin to internal CM bias voltage. Channel 4.
RX5N	17	I	Inverting differential inputs to the equalizer. Integrated 50 Ω termination resistor from the pin to internal CM bias voltage. Channel 5.
RX5P	16	I	Noninverting differential inputs to the equalizer. An on-chip, 100 Ω termination resistor connects RXP to RXN. Channel 5.
RX6N	20	I	Inverting differential inputs to the equalizer. Integrated 50 Ω termination resistor from the pin to internal CM bias voltage. Channel 6.
RX6P	19	I	Noninverting differential inputs to the equalizer. Integrated 50 Ω termination resistor from the pin to internal CM bias voltage. Channel 6.
RX7N	23	I	Inverting differential inputs to the equalizer. Integrated 50 Ω termination resistor from the pin to internal CM bias voltage. Channel 7.
RX7P	22	I	Noninverting differential inputs to the equalizer. Integrated 50 Ω termination resistor from the pin to internal CM bias voltage. Channel 7.
TX0N	54	O	Inverting pin for 100 Ω differential driver output. Channel 0.
TX0P	55	O	Non-inverting pin for 100 Ω differential driver output. Channel 0.
TX1N	51	O	Inverting pin for 100 Ω differential driver output. Channel 1.
TX1P	52	O	Non-inverting pin for 100 Ω differential driver output. Channel 1.
TX2N	48	O	Inverting pin for 100 Ω differential driver output. Channel 2.
TX2P	49	O	Non-inverting pin for 100 Ω differential driver output. Channel 2.
TX3N	45	O	Inverting pin for 100 Ω differential driver output. Channel 3.

PIN		I/O, TYPE	DESCRIPTION
NAME	NO.		
TX3P	46	O	Non-inverting pin for 100 Ω differential driver output. Channel 3.
TX4N	42	O	Inverting pin for 100 Ω differential driver output. Channel 4.
TX4P	43	O	Non-inverting pin for 100 Ω differential driver output. Channel 4.
TX5N	39	O	Inverting pin for 100 Ω differential driver output. Channel 5.
TX5P	40	O	Non-inverting pin for 100 Ω differential driver output. Channel 5.
TX6N	36	O	Inverting pin for 100 Ω differential driver output. Channel 6.
TX6P	37	O	Non-inverting pin for 100 Ω differential driver output. Channel 6.
TX7N	33	O	Inverting pin for 100 Ω differential driver output. Channel 7.
TX7P	34	O	Non-inverting pin for 100 Ω differential driver output. Channel 7.
VCC	6, 18, 38, 50	P	Power supply pins. VCC = 3.3 V \pm 10%. The VCC pins on this device should be connected through a low-resistance path to the board VCC plane.
VREG1	3, 47	P	Internal voltage regulator output. Must add decoupling caps of 0.1 μ F near each pins. The regulator is only for internal use. Do not use to provide power to any external component. Do not connect to VREG2.
VREG2	15, 35	P	Internal voltage regulator output. Must add decoupling caps of 0.1 μ F near each pins. The regulator is only for internal use. Do not use to provide power to any external component. Do not connect to VREG1.

6 Specifications

6.1 Absolute Maximum Ratings

over operating free-air temperature range (unless otherwise noted)⁽¹⁾

		MIN	MAX	UNIT
VCC_ABSMAX	Supply voltage (VCC)	-0.5	4.0	V
VIO_CMOS_ABSMAX	3.3 V LVCMOS and open drain I/O voltage	-0.5	4.0	V
VIO_4LVL_ABSMAX	4-level input I/O voltage	-0.5	2.75	V
VIO_HS-RX_ABSMAX	High-speed I/O voltage (RXnP, RXnN)	-0.5	3.2	V
VIO_HS-TX_ABSMAX	High-speed I/O voltage (TXnP, TXnN)	-0.5	2.75	V
T_J_ABSMAX	Junction temperature		150	°C
T_stg	Storage temperature range	-65	150	°C

- (1) Stresses beyond those listed under Absolute Maximum Ratings may cause permanent damage to the device. These are stress ratings only, which do not imply functional operation of the device at these or any other conditions beyond those indicated under Recommended Operating Conditions. Exposure to absolute-maximum-rated conditions for extended periods may affect device reliability.

6.2 ESD Ratings

			VALUE	UNIT
V _(ESD)	Electrostatic discharge	Human body model (HBM), per ANSI/ESDA/JEDEC JS-001 ⁽¹⁾	±3000	V
		Charged device model (CDM), per JEDEC specification JESD22-C101 ⁽²⁾	±500	

- (1) JEDEC document JEP155 states that 500-V HBM allows safe manufacturing with a standard ESD control process. Pins listed as ±3 kV may actually have higher performance.
- (2) JEDEC document JEP157 states that 250-V CDM allows safe manufacturing with a standard ESD control process.

6.3 Recommended Operating Conditions

over operating free-air temperature range (unless otherwise noted)

			MIN	NOM	MAX	UNIT
VCC	Supply voltage, VCC to GND	DC plus AC power should not exceed these limits	3.0	3.3	3.6	V
N _{VCC}	Supply noise tolerance ¹	DC to <50 Hz, sinusoidal			250	mVpp
		50 Hz to 500 kHz, sinusoidal			100	mVpp
		500 kHz to 2.5 MHz, sinusoidal			33	mVpp
		>2.5 MHz, sinusoidal			10	mVpp
T _{RampVCC}	VCC supply ramp time	From 0 V to 3.0 V	0.150		100	ms
T _J	Operating junction temperature		-40		115	°C
T _A	Operating ambient temperature		-40		85	°C
PW _{LVCMOS}	Minimum pulse width required for the device to detect a valid signal on LVCMOS inputs	PD1/0, SEL1/0, and READ_EN_N	200			µs
VCC _{SMBUS}	SMBus/I ² C SDA and SCL open drain termination voltage	Supply voltage for open drain pull-up resistor			3.6	V
F _{SMBus}	SMBus/I ² C clock (SCL) frequency in SMBus slave mode		10		400	kHz
VID _{LAUNCH}	Source differential launch amplitude		800		1200	mVpp
DR	Data rate		1		16	Gbps

6.4 Thermal Information

THERMAL METRIC ⁽¹⁾		DS160PR 8 22	UNIT
		NJX, 64 Pins	
R _{θJA-High K}	Junction-to-ambient thermal resistance	22.9	°C/W
R _{θJC(top)}	Junction-to-case (top) thermal resistance	9.6	°C/W
R _{θJB}	Junction-to-board thermal resistance	7.2	°C/W
ψ _{JT}	Junction-to-top characterization parameter	1.8	°C/W
ψ _{JB}	Junction-to-board characterization parameter	7.1	°C/W
R _{θJC(bot)}	Junction-to-case (bottom) thermal resistance	2.5	°C/W

(1) For more information about traditional and new thermal metrics, see the [IC Package Thermal Metrics application report](#).

6.5 DC Electrical Characteristics

over operating free-air temperature and voltage range (unless otherwise noted)

PARAMETER		TEST CONDITIONS	MIN	TYP	MAX	UNIT
Power						
POWER _{CH}	Active power per channel	GAIN1/0 = L3 (default)		107		mW
		GAIN1/0 = L0		99		mW
I _{ACTIVE-8CH}	Device current consumption when all eight channels are active	GAIN1/0 = L3		260	360	mA
I _{STBY}	Device current consumption in standby power mode	All channels disabled (PD1,0 = H)		30	45	mA
V _{REG}	Internal regulator output			2.5		V
Control IO (SDA, SCL, PD1, PD0, READ_EN_N, SEL1, SEL0 pins)						
V _{IH}	High level input voltage	SDA, SCL, PD1, PD0, READ_EN_N, SEL1, SEL0 pins	2.1			V
V _{IL}	Low level input voltage	SDA, SCL, PD1, PD0, READ_EN_N, SEL1, SEL0 pins			1.08	V
V _{OH}	High level output voltage	R _{pull-up} = 4.7 kΩ (SDA, SCL, ALL_DONE_N pins)	2.1			V
V _{OL}	Low level output voltage	I _{OL} = -4 mA (SDA, SCL, ALL_DONE_N pins)			0.4	V
I _{IH,SEL}	Input high leakage current for SEL pins	V _{Input} = VCC for SEL1, SEL0 pins			80	μA
I _{IH}	Input high leakage current	V _{Input} = VCC, (SCL, SDA, PD1, PD0, READ_EN_N pins)			10	μA
I _{IL}	Input low leakage current	V _{Input} = 0 V, (SCL, SDA, PD1, PD0, READ_EN_N, SEL1, SEL0 pins)	-10			μA
I _{IH,FS}	Input high leakage current for fail safe input pins	V _{Input} = 3.6 V, VCC = 0 V, (SCL, SDA, PD1, PD0, READ_EN_N, SEL1, SEL0 pins)			200	μA
C _{IN-CTRL}	Input capacitance	SDA, SCL, PD1, PD0, READ_EN_N, SEL1, SEL0 pins		1.5		pF
4 Level IOs (MODE, GAIN0, GAIN1, EQ0_0, EQ1_0, EQ0_1, EQ1_1, RX_DET pins)						
I _{IH_4L}	Input high leakage current, 4 level IOs	VIN = 2.5 V			10	μA
I _{IL_4L}	Input low leakage current for all 4 level IOs except MODE.	VIN = GND	-10			μA
I _{IL_4L,MODE}	Input low leakage current for MODE pin	VIN = GND	-200			μA
Receiver						

over operating free-air temperature and voltage range (unless otherwise noted)

PARAMETER		TEST CONDITIONS	MIN	TYP	MAX	UNIT
V _{RX-DC-CM}	RX DC common mode (CM) voltage	Device is in active or standby state		2.5		V
Z _{RX-DC}	Rx DC single-ended impedance			50		Ω
Z _{RX-HIGH-IMP-DC-POS}	DC input CM input impedance during Reset or power-down	Inputs are at CM voltage	20			kΩ
Transmitter						
Z _{TX-DIFF-DC}	DC differential Tx impedance	Impedance of Tx during active signaling, VID,diff = 1Vpp		100		Ω
V _{TX-DC-CM}	Tx DC common mode Voltage			0.75		V
I _{TX-SHORT}	Tx Short circuit current	Total current the Tx can supply when shorted to GND			90	mA

6.6 High Speed Electrical Characteristics

over operating free-air temperature and voltage range (unless otherwise noted)

PARAMETER		TEST CONDITIONS	MIN	TYP	MAX	UNIT
Receiver						
R _{L-RX-DIFF}	Input differential return loss	50 MHz to 1.25 GHz		-25		dB
		1.25 GHz to 2.5 GHz		-22		dB
		2.5 GHz to 4.0 GHz		-21		dB
		4.0 GHz to 8.0 GHz		-16		dB
X _{T-RX}	Receive-side pair-to-pair isolation	Pair-to-pair isolation (SDD21) between two adjacent receiver pairs from 10 MHz to 8 GHz.		-47		dB
Transmitter						
V _{TX-AC-CM-PP}	Tx AC peak-to-peak common mode voltage	Measured with lowest EQ, VOD = L2; PRBS-7, 16 Gbps, over at least 10E6 bits using a bandpas filter from 30 Khz to 500 Mhz			50	mVpp
V _{TX-CM-DC-ACTIVE-IDLE-DELTA}	Absolute delta of DC common mode voltage during L0 and Electrical Idle	$V_{TX-CM-DC} = V_{OUTn+} + V_{OUTn-} /2$, measured by taking the absolute difference of V _{TX-CM-DC} during PCIe state L0 and Electrical Idle	0		100	mV
V _{TX-CM-DC-LINE-DELTA}	Absolute delta of DC common mode voltage between V _{OUTn+} and V _{OUTn-} during L0	Measured by taking the absolute difference of V _{OUTn+} and V _{OUTn-} during PCIe state L0			10	mV
V _{TX-IDLE-DIFF-AC-p}	AC Electrical Idle differential output voltage	Measured by taking the absolute difference of V _{OUTn+} and V _{OUTn-} during Electrical Idle, measured with a band-pass filter consisting of two first-order filters. The high-pass and low-pass -3-dB bandwidths are 10 kHz and 1.25 GHz, respectively - zero at input	0		10	mV
V _{TX-IDLE-DIFF-DC}	DC Electrical Idle differential output voltage	Measured by taking the absolute difference of V _{OUTn+} and V _{OUTn-} during Electrical Idle, measured with a first-order low-pass Filter with -3-dB bandwidth of 10 kHz	0		5	mV
V _{TX-RCV-DETECT}	Amount of voltage change allowed during receiver detection	Measured while Tx is sensing whether a low-impedance Receiver is present. No load is connected to the driver output	0		600	mV

over operating free-air temperature and voltage range (unless otherwise noted)

PARAMETER		TEST CONDITIONS	MIN	TYP	MAX	UNIT
RL _{TX-DIFF}	Output differential return loss	50 MHz to 1.25 GHz		-20		dB
		1.25 GHz to 2.5 GHz		-18		dB
		2.5 GHz to 4.0 GHz		-18		dB
		4.0 GHz to 8.0 GHz		-17		dB
XT _{TX}	Transmit-side pair-to-pair isolation	Minimum pair-to-pair isolation (SDD21) between two adjacent transmitter pairs from 10 MHz to 8 GHz.		-48		dB

Device Datapath

T _{PLHD/PHLD}	Input-to-output latency (propagation delay) through a data channel	For either low-to-high or high-to-low transition.		90	120	ps
L _{TX-SKEW}	Lane-to-lane output skew	Between any two lanes within a single transmitter.	-20		20	ps
T _{RJ-DATA}	Additive random jitter with data	Jitter through redriver minus the calibration trace. 16Gbps PRBS15. Minimal input/output channels. Minimum EQ. 800 mVpp-diff input swing.		70		fs
T _{RJ-INTRINSIC}	Intrinsic additive random jitter with clock	Jitter through redriver minus the calibration trace. 8 Ghz CK. Minimal input/output channels. Minimum EQ. 400 mVpp-diff input swing.		90		fs
JITTER _{TOTAL-DATA}	Additive total jitter with data	Jitter through redriver minus the calibration trace. 16 Gbps PRBS15. Minimal input/output channels. Minimum EQ. 800 mVpp-diff input swing.		4		ps
JITTER _{TOTAL-INTRINSIC}	Intrinsic additive total jitter with clock	Jitter through redriver minus the calibration trace. 8 Ghz CK. Minimal input/output channels. Minimum EQ. 800 mVpp-diff input swing.		1		ps
FLAT-GAIN	Flat gain (DC and AC) input to output	Minimum EQ, GAIN1/0=L0		-4.2		dB
		Minimum EQ, GAIN1/0=L1		-1.8		dB
		Minimum EQ, GAIN1/0=L2		0.25		dB
		Minimum EQ, GAIN1/0=L3 (float, default)		2		dB
EQ-MAX _{8G}	EQ boost at max setting (EQ INDEX = 15)	AC gain at 8 GHz relative to gain at 100 MHz. GAIN1/0=L3 (float, default).		18.0		dB
DCGAIN _{VAR}	DC gain variation	GAIN1/0 = L2, minimum EQ setting. Max-Min.	-2.3		1.7	dB
EQGAIN _{VAR}	EQ boost variation	At 8 Ghz. GAIN1/0 = L2, maximum EQ setting. Max-Min.	-3.3		3.7	dB
LIN _{DC}	Output DC linearity	GAIN1/0 = L3 (float, default). 128T pattern at 2.5 Gbps.		1000		mVpp
LIN _{AC}	Output AC linearity	GAIN1/0 = L3 (float, default). 1T pattern at 16 Gbps.		750		mVpp

6.7 SMBUS/I2C Timing Characteristics

over operating free-air temperature range (unless otherwise noted)

PARAMETER		TEST CONDITIONS	MIN	TYP	MAX	UNIT
Slave Mode						
t _{SP}	Pulse width of spikes which must be suppressed by the input filter				50	ns

over operating free-air temperature range (unless otherwise noted)

PARAMETER		TEST CONDITIONS	MIN	TYP	MAX	UNIT
t_{HD-STA}	Hold time (repeated) START condition. After this period, the first clock pulse is generated		0.6			μs
t_{LOW}	LOW period of the SCL clock		1.3			μs
T_{HIGH}	HIGH period of the SCL clock		0.6			μs
t_{SU-STA}	Set-up time for a repeated START condition		0.6			μs
t_{HD-DAT}	Data hold time		0			μs
t_{SU-DAT}	Data setup time		0.1			μs
t_r	Rise time of both SDA and SCL signals	Pull-up resistor = 4.7 k Ω , C _b = 10pF		120		ns
t_f	Fall time of both SDA and SCL signals	Pull-up resistor = 4.7 k Ω , C _b = 10pF		2		ns
t_{SU-STO}	Set-up time for STOP condition		0.6			μs
t_{BUF}	Bus free time between a STOP and START condition		1.3			μs
t_{VD-DAT}	Data valid time				0.9	μs
t_{VD-ACK}	Data valid acknowledge time				0.9	μs
C _b	capacitive load for each bus line				400	pF
Master Mode						
f_{SCL-M}	SCL clock frequency	MODE = L1 (Master Mode)		303		kHz
t_{LOW-M}	SCL low period			1.9		μs
t_{HIGH-M}	SCL high period			1.4		μs
$t_{SU-STA-M}$	Set-up time for a repeated START condition			2		μs
$t_{HD-STA-M}$	Hold time (repeated) START condition. After this period, the first clock pulse is generated			1.5		μs
$t_{SU-DAT-M}$	Data setup time			1.4		μs
$t_{HD-DAT-M}$	Data hold time			0.5		μs
t_{R-M}	Rise time of both SDA and SCL signals	Pull-up resistor = 4.7 k Ω , C _b = 10pF		120		ns
t_{F-M}	Fall time of both SDA and SCL signals	Pull-up resistor = 4.7 k Ω , C _b = 10pF		2		ns
$t_{SU-STO-M}$	Stop condition setup time			1.5		μs
EEPROM Timing						
T_{EEPROM}	EEPROM configuration load time	Time to assert ALL_DONE_N after READ_EN_N has been asserted. Single device reading its configuration from an EEPROM with common channel configuration with individual channel settings . This time scales with the number of devices reading from the same EEPROM. Does not include power-on reset time.		7.5		ms
T_{POR}	Time to first SMBus access	Power supply stable after initial ramp. Includes initial power-on reset time.		50		ms

6.8 Typical Characteristics

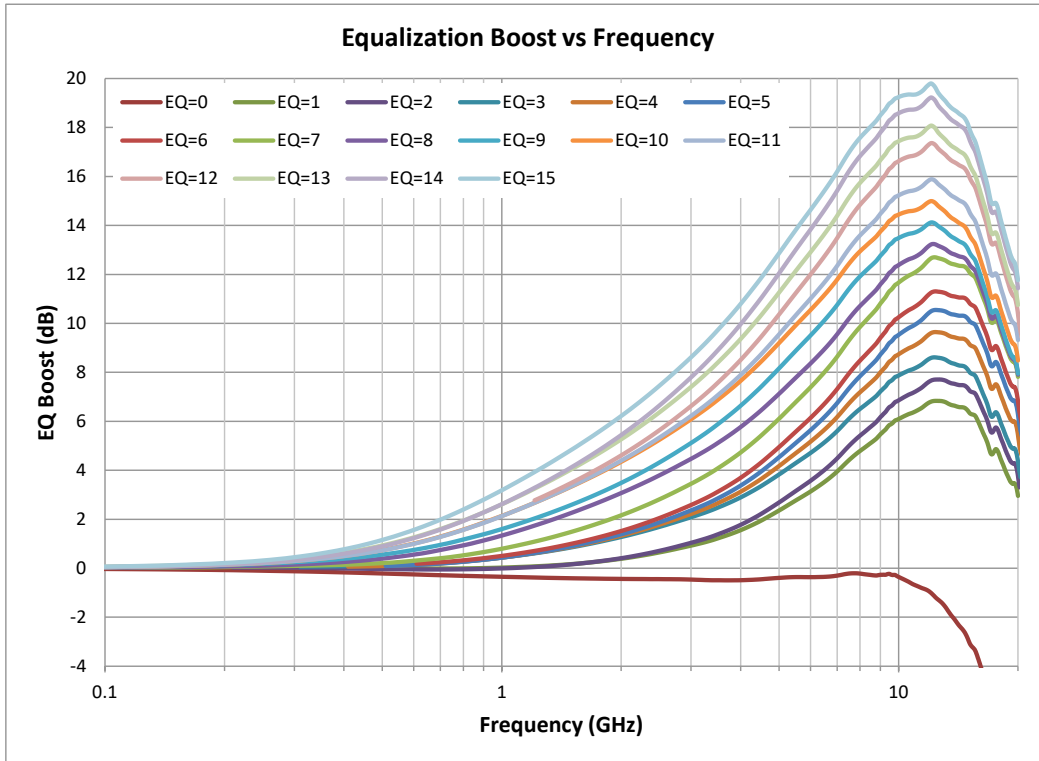

Figure 6-1. Typical EQ Boost vs Frequency

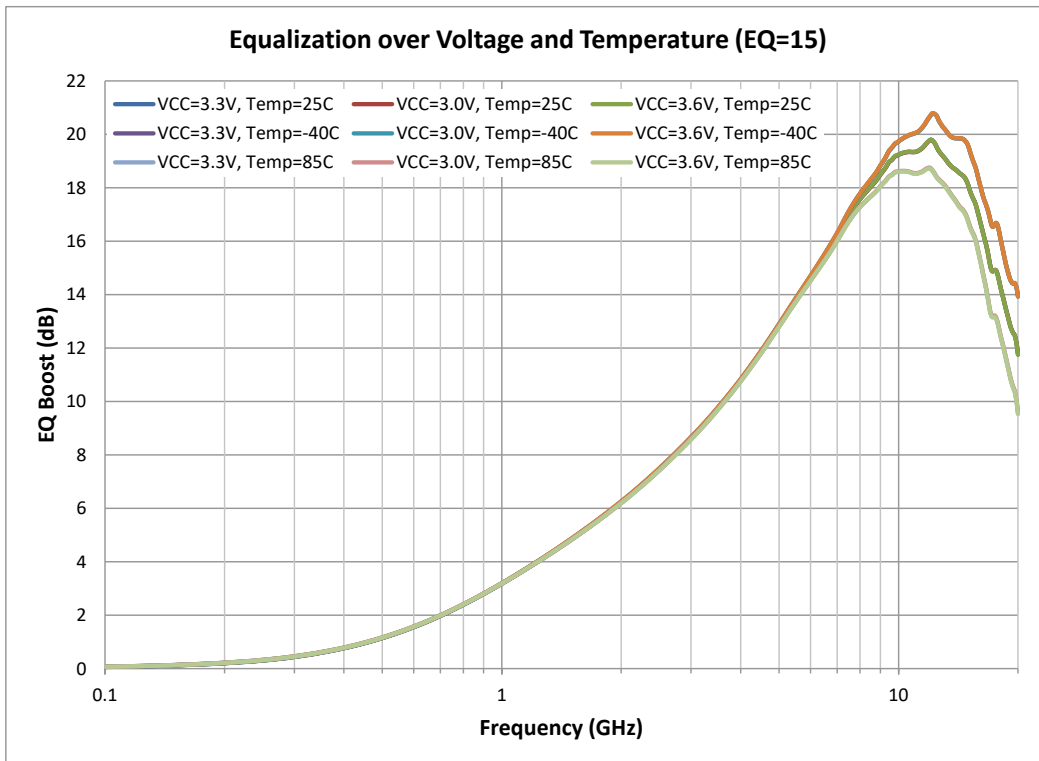

Figure 6-2. Typical EQ Boost over Voltage and Temperature with EQ=15

6.8 Typical Characteristics

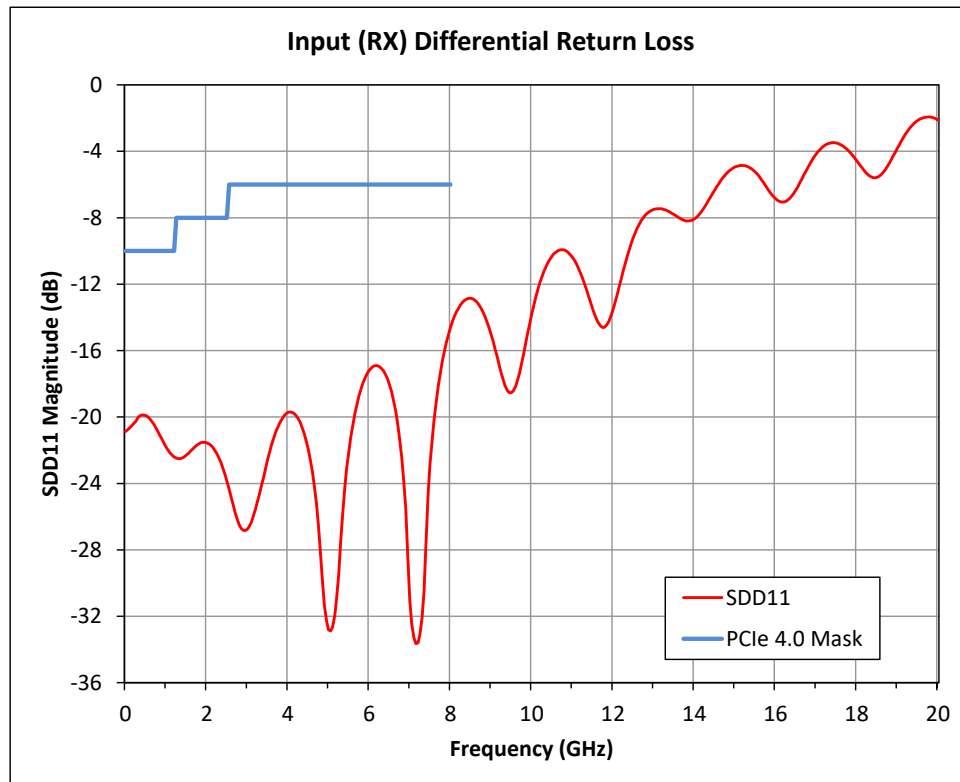
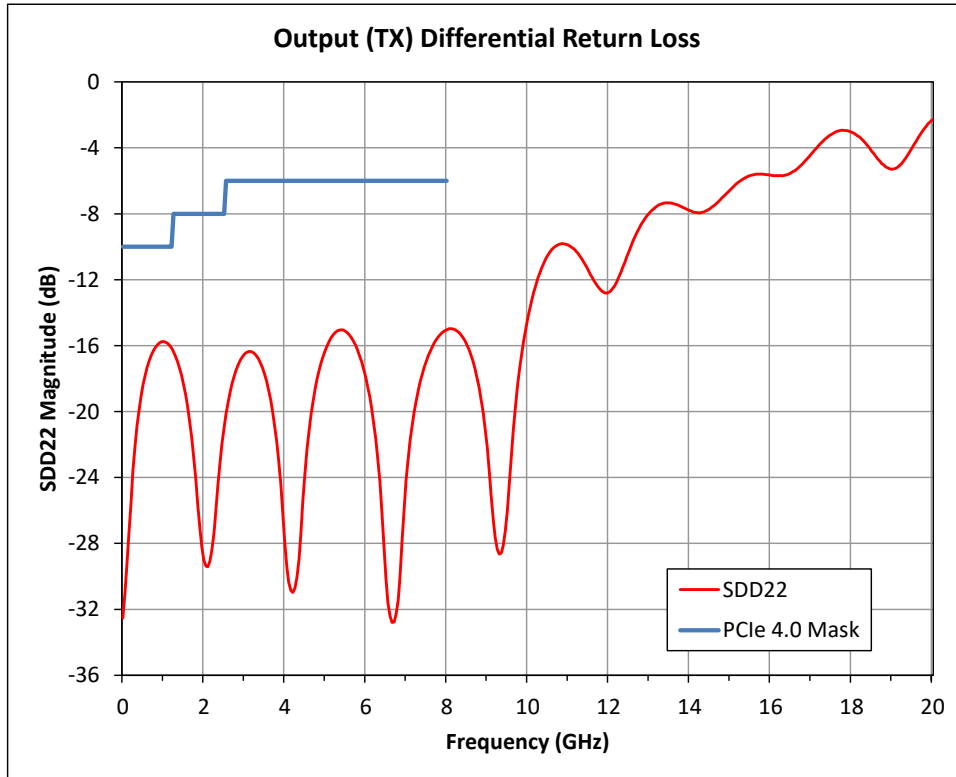
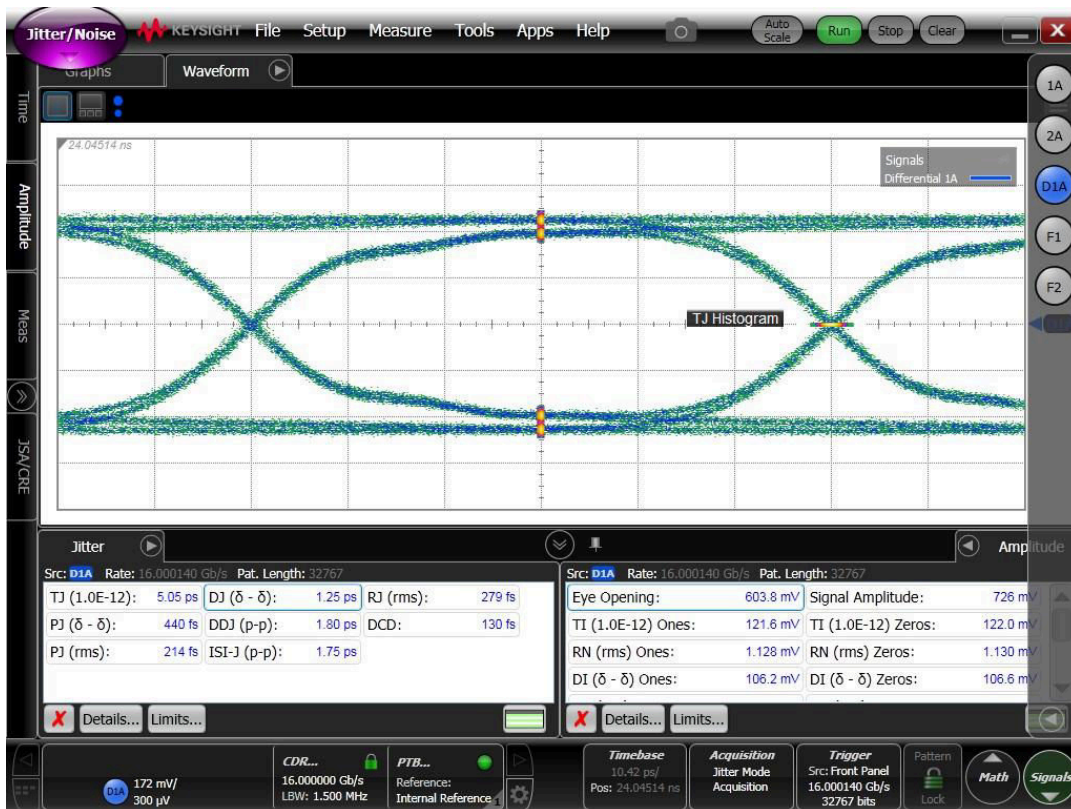

Figure 6-3. Typical RX Differential Return Loss

6.8 Typical Characteristics



6-4. Typical TX Differential Return Loss



6.8 Typical Characteristics

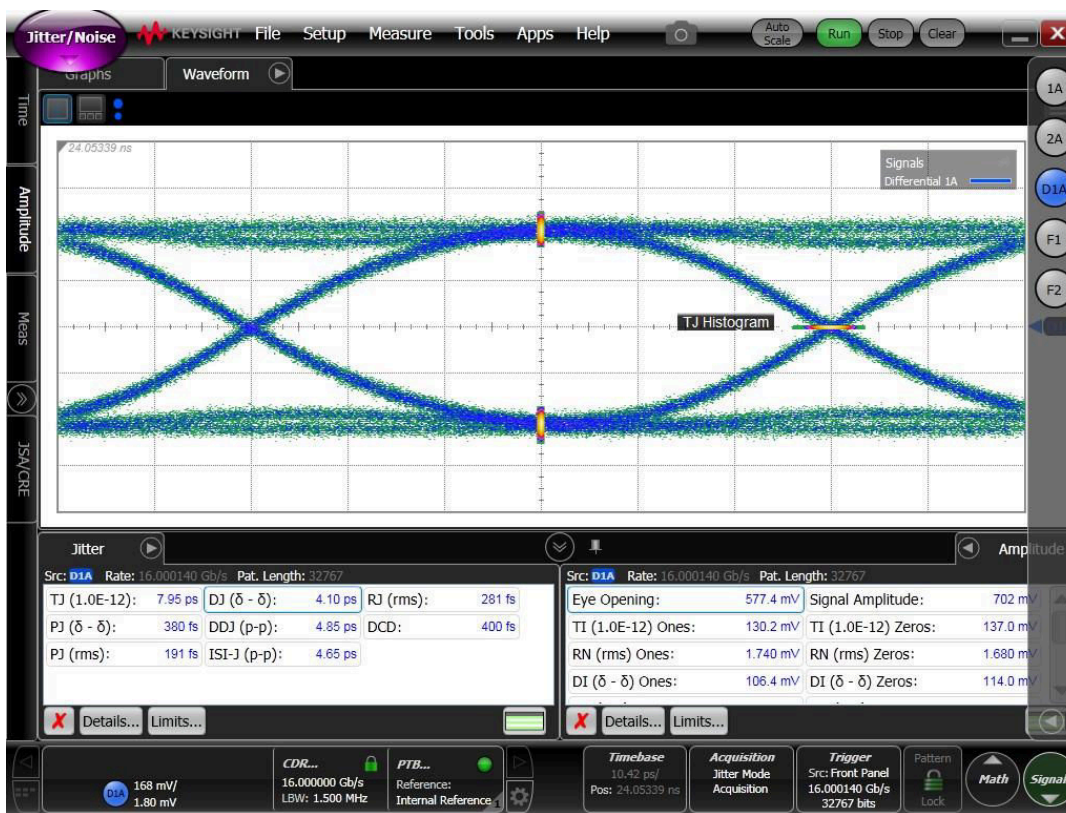

6-5. Typical Jitter Characteristics - Top: 16Gb/s PRBS15 Input to the Device, Bottom: Output of the Device.

7 Detailed Description

7.1 Overview

The DS160PR822 is an eight-channel multi-rate linear repeater with integrated signal conditioning. The device provides quad 2x2 crosspoint mux functionality selectable by pin control or SMBus/I²C. The device's signal channels operate independently from one another. Each channel includes a continuous-time linear equalizer (CTLE) and a linear output driver, which together compensate for a lossy transmission channel between the source transmitter and the final receiver. The linearity of the data path is specifically designed to preserve any transmit equalization while keeping receiver equalization effective.

The DS160PR822 can be configured three different ways:

Pin Mode – device control configuration is done solely by strap pins. Pin mode is expected to be good enough for many system implementation needs.

SMBus/I²C Master Mode - device control configuration is read from external EEPROM. When the device has finished reading from the EEPROM successfully, it will drive the ALL_DONE_N pin LOW. SMBus/I²C slave operation is available in this mode before, during or after EEPROM reading. Note during EEPROM reading if the external SMBus/I²C master wants to access device registers it must support arbitration. The mode is preferred when software implementation is not desired.

SMBus/I²C Slave Mode - provides most flexibility. Requires a SMBus/I²C master device to configure the device through writing to its slave address.

7.2 Functional Block Diagram

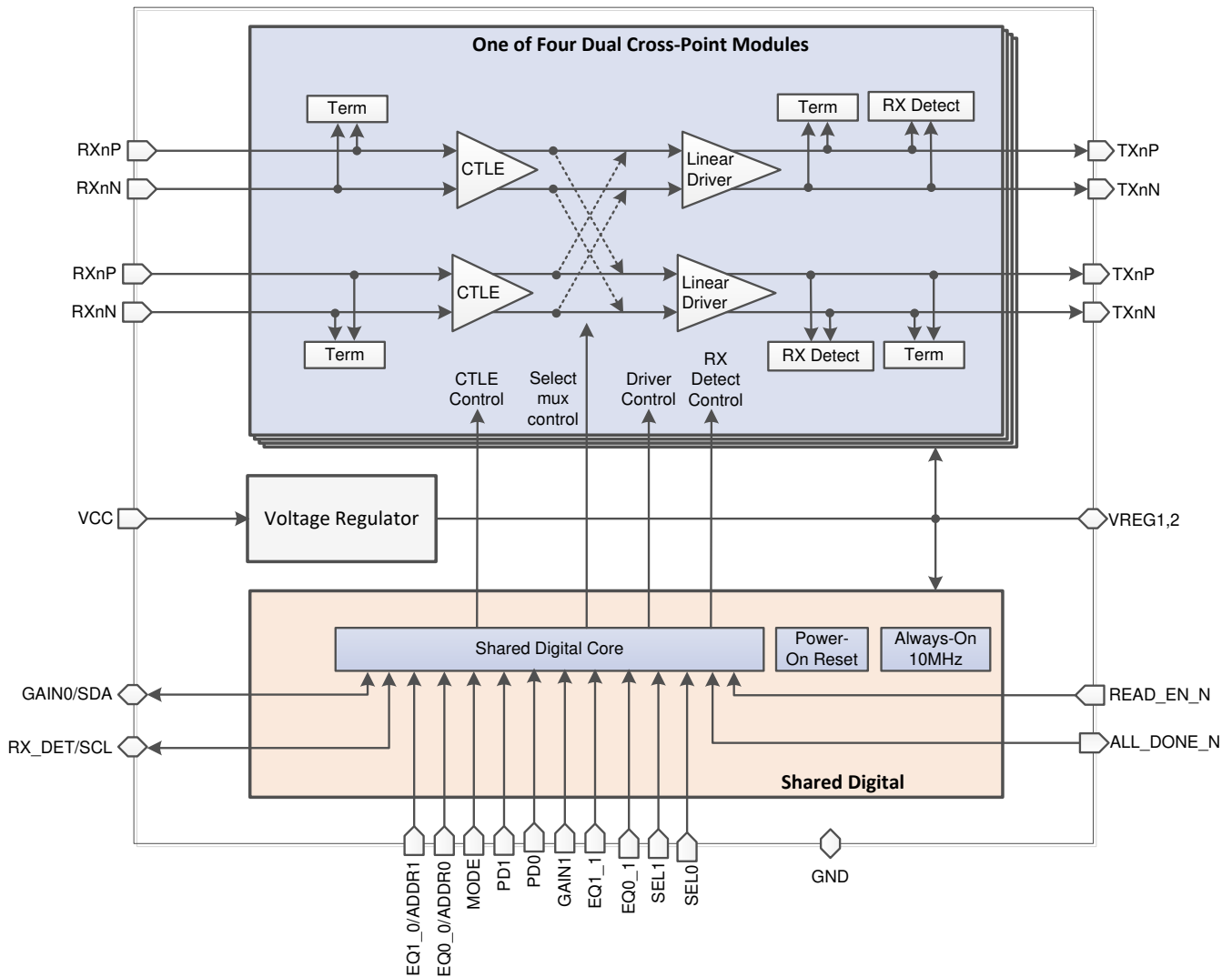

7.3 Feature Description

7.3.1 Linear Equalization

The DS160PR822 receivers feature a continuous-time linear equalizer (CTLE) that applies high-frequency boost and low-frequency attenuation to help equalize the frequency-dependent insertion loss effects of the passive channel. 表 7-1 shows available equalization boost through EQ control pins (EQ1_0 and EQ0_0 for channels 0-3 and EQ1_1 and EQ0_1 for channels 4-7), when in Pin Control mode (MODE = L0).

表 7-1. Equalization Control Settings

EQ INDEX	EQUALIZATION SETTING		TYPICAL EQ BOOST (dB)	
	EQ1_0 (Ch 0-3) / EQ1_1 (Ch 4-7)	EQ0_0 (Ch0-3) / EQ0_1 (Ch 4-7)	@ 4 GHz	@ 8 GHz
0	L0	L0	0.0	-0.2
1	L0	L1	1.5	4.5
2	L0	L2	2.0	5.5
3	L0	L3	2.5	6.5
4	L1	L0	2.7	7.0
5	L1	L1	3.0	8.0

表 7-1. Equalization Control Settings (continued)

EQUALIZATION SETTING			TYPICAL EQ BOOST (dB)	
EQ INDEX	EQ1_0 (Ch 0-3) / EQ1_1 (Ch 4-7)	EQ0_0 (Ch0-3) / EQ0_1 (Ch 4-7)	@ 4 GHz	@ 8 GHz
6	L1	L2	4.0	9.0
7	L1	L3	5.0	10.0
8	L2	L0	6.0	11.0
9	L2	L1	7.0	12.0
10	L2	L2	7.5	13.0
11	L2	L3	8.0	13.5
12	L3	L0	8.5	15.0
13	L3	L1	9.5	16.5
14	L3	L2	10.0	17.0
15	L3	L3	11.0	18.0

The equalization of the device can also be set by writing to SMBus/I²C registers in slave or master mode. Refer to the [DS160PR822 Programming Guide](#) (SNLU279) for details.

7.3.2 Flat Gain

The GAIN1 and GAIN0 pins can be used to set the overall datapath flat gain (DC and AC) of the DS160PR822 when the device is in Pin Mode. The pin GAIN0 sets the flat gain for channels 0-3 and GAIN1 sets the same for channels 4-7. The default recommendation for most systems will be GAIN1,0 = L3 (float).

The flat gain and equalization of the DS160PR822 must be set such that the output signal swing at DC and high frequency does not exceed the DC and AC linearity ranges of the devices, respectively.

7.3.3 Receiver Detect State Machine

The DS160PR822 deploys an RX detect state machine that governs the RX detection cycle as defined in the PCI express specifications. At power up, after a manually triggered event through PD0 and/or PD1 pins (in pin mode), or writing to the relevant I²C/SMBus register, the redriver determines whether or not a valid PCI express termination is present at the far end of the link. The RX_DET pin of DS160PR822 provides additional flexibility for system designers to appropriately set the device in desired mode according to [表 7-2](#). PD0 and PD1 pins impact channel groups 0-3 and 4-7 respectively. If all eight channels of DS160PR822 is used for a same PCI express link, the PD1 and PD0 pins can be shorted and driven together. For most applications the RX_DET pin can be left floating for default settings. Note mux selection pins SEL0 and SEL1 also triggers the RX detect state machine.

表 7-2. Receiver Detect State Machine Settings

PD0	PD1	RX_DET	Channels 0-3 RX Common-mode Impedance	Channels 4-7 RX Common-mode Impedance	COMMENTS
L	L	L0	Always 50Ω	Always 50Ω	PCI Express RX detection state machine is disabled. Recommended for non PCIe interface use case where the DS160PR822 is used as buffer with equalization.
L	L	L3 (Float)	Pre Detect: Hi-Z Post Detect: 50 Ω.	Pre Detect: Hi-Z Post Detect: 50 Ω.	TX polls every ~150us until valid termination is detected. RX CM impedance held at Hi-Z until detection Reset by asserting PD0/1 high for 200μs then low.
H	L	X	Hi-Z	Pre Detect: Hi-Z Post Detect: 50 Ω.	Reset Channels 0-3 signal path and set their RX impedance to Hi-Z
L	H	X	Pre Detect: Hi-Z Post Detect: 50 Ω.	Hi-Z	Reset Channels 4-7 signal path and set their RX impedance to Hi-Z.
H	H	X	Hi-Z	Hi-Z	

7.3.4 Cross Point

The DS160PR822 provides quad 2x2 cross-point function. Using pin SEL1, SEL0 pins the 8 channel signal paths can be configured as straight connection or quad cross connections. SEL1 pin impacts channel 0-3 and SEL1 configures channels 4-7.

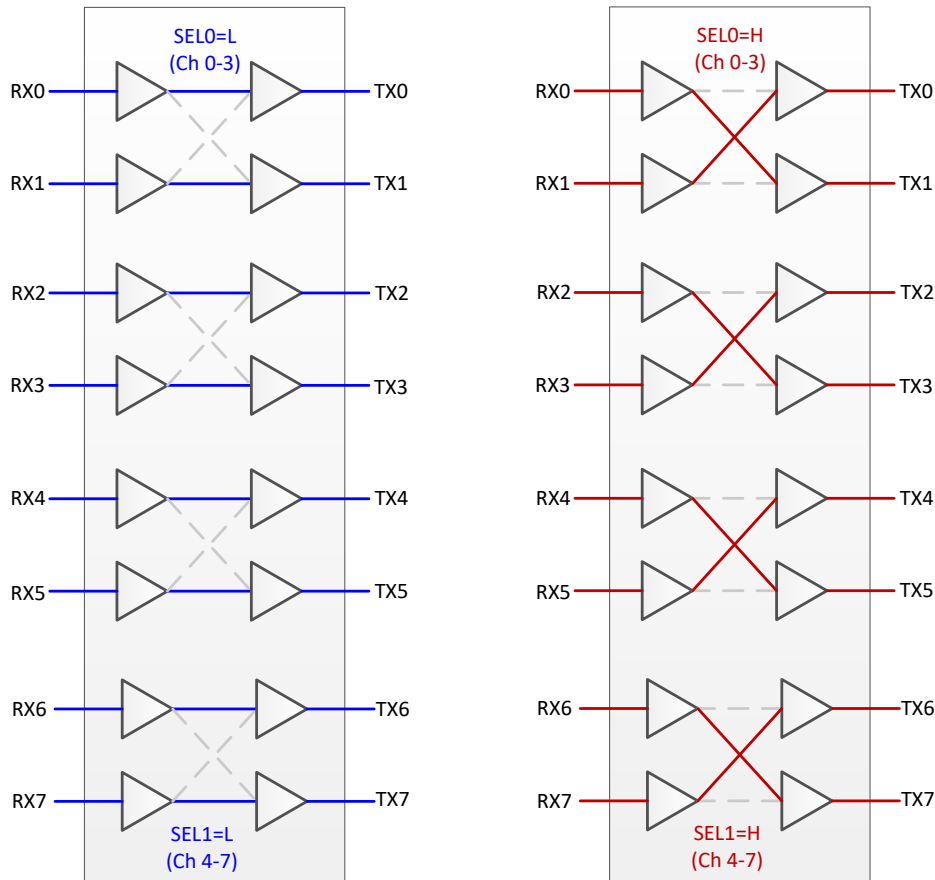

7-1. DS160PR822 Signal Flow Diagram for Cross-Point Mux Operation

7.4 Device Functional Modes

7.4.1 Active PCIe Mode

The device is in normal operation with PCIe state machine enabled by RX_DET = L1/L2/L3. In this mode PD0/PD1 pins are driven low in a system (for example by PCIE connector "PRSNT" signal). In this mode, the DS160PR822 redrives and equalizes PCIe RX or TX signals to provide better signal integrity.

7.4.2 Active Buffer Mode

The device is in normal operation with PCIe state machine disabled by RX_DET = L0. This mode is recommended for non-PCIe use cases. In this mode the device is working as a buffer to provide linear equalization to improve signal integrity.

7.4.3 Standby Mode

The device is in standby mode invoked by PD1,0 = H. In this mode, the device is in standby mode conserving power.

7.5 Programming

7.5.1 Control and Configuration Interface

7.5.1.1 Pin Mode

The DS160PR822 can be fully configured through pin-strap pins. In this mode the device uses 2-level and 4-level pins for device control and signal integrity optimum settings. The [セクション 5](#) section defines the control pins.

7.5.1.1.1 Four-Level Control Inputs

The DS160PR822 has 4-level inputs pins (EQ0_0, EQ1_0, EQ0_1, EQ1_1, GAIN0, GAIN1, MODE, and RX_DET) that are used to control the configuration of the device. These 4-level inputs use a resistor divider to help set the 4 valid levels and provide a wider range of control settings. External resistors must be of 10% tolerance or better. The pins are sampled at power-up only. The MODE pin can be exercised at device power up or in normal operation mode.

表 7-3. 4-Level Control Pin Settings

LEVEL	SETTING
L0	1 kΩ to GND
L1	13 kΩ to GND
L2	59 kΩ to GND
L3	F (Float)

7.5.1.2 SMBUS/I²C Register Control Interface

If MODE = L2 (SMBus / I²C slave control mode), the DS160PR822 is configured for best signal integrity through a standard I²C or SMBus interface that may operate up to 400 kHz. The slave address of the device is determined by the pin strap settings on the ADDR1 and ADDR0 pins. Note slave addresses to access channel 0-3 and Channels 4-7 is different. Channel bank 4-7 has address which is Channel bank 0-3 address +1. The sixteen possible slave addresses (8-bit) for each channel banks of the the device are shown in [表 7-4](#). In SMBus/I²C modes the SCL, SDA pins must be pulled up to a 3.3 V supply with a pull-up resistor. The value of the resistor depends on total bus capacitance. 4.7 kΩ is a good first approximation for a bus capacitance of 50 pF.

Refer to the [DS160PR822 Programming Guide](#) (SNLU279) for register map details.

表 7-4. SMBUS/I²C Slave Address Settings

ADDR1	ADDR0	7-bit Slave Address Channels 0-3	7-bit Slave Address Channels 4-7
L0	L0	0x18	0x19
L0	L1	0x1A	0x1B
L0	L2	0x1C	0x1D
L0	L3	0x1E	0x1F
L1	L0	0x20	0x21
L1	L1	0x22	0x23
L1	L2	0x24	0x25
L1	L3	0x26	0x27
L2	L0	0x28	0x29
L2	L1	0x2A	0x2B
L2	L2	0x2C	0x2D
L2	L3	0x2E	0x2F
L3	L0	0x30	0x31
L3	L1	0x32	0x33
L3	L2	0x34	0x35

表 7-4. SMBUS/I²C Slave Address Settings (continued)

ADDR1	ADDR0	7-bit Slave Address Channels 0-3	7-bit Slave Address Channels 4-7
L3	L3	0x36	0x37

7.5.1.3 SMBus/I²C Master Mode Configuration (EEPROM Self Load)

The DS160PR822 can also be configured by reading from EEPROM. To enter into this mode MODE pin must be set to L1. The EEPROM load operation only happens once after device's initial power-up. If the device is configured for SMBus master mode, it will remain in the SMBus IDLE state until the READ_EN_N pin is asserted to LOW. After the READ_EN_N pin is driven LOW, the device becomes an SMBus master and attempts to self-configure by reading device settings stored in an external EEPROM (SMBus 8-bit address 0xA0). When the device has finished reading from the EEPROM successfully, it will drive the ALL_DONE_N pin LOW. SMBus/I²C slave operation is available in this mode before, during or after EEPROM reading. Note during EEPROM reading if the external SMBus/I²C master wants to access the device registers it must support arbitration. Refer to the [Understanding EEPROM Programming for PCI-Express 4.0 Redrivers](#) (SNLA342) application report for more information.

When designing a system for using the external EEPROM, the user must follow these specific guidelines:

- EEPROM size of 2 kb (256 × 8-bit) is recommended.
- Set MODE = L1, configure for SMBus master mode
- The external EEPROM device address byte must be 0xA0 and capable of 400 kHz operation at 3.3 V supply
- In SMBus/I²C modes the SCL, SDA pins must be pulled up to a 3.3 V supply with a pull-up resistor. The value of the resistor depends on total bus capacitance. 4.7 kΩ is a good first approximation for a bus capacitance of 10 pF.

Figure 7-2 shows a use case with four DS160PR822 to implement a 2x2 crosspoint for a x8 link configuration, but the user can cascade any number of DS160PR822 devices in a similar way. Tie first device's READ_EN_N pin low to automatically initiate EEPROM read at power up. Alternately the READ_EN_N pin of the first device can also be controlled by a microcontroller to initiate the EEPROM read manually. Leave the final device's ALL_DONE_N pin floating, or connect the pin to a microcontroller input to monitor the completion of the final EEPROM read.



图 7-2. Daisy Chain Four DS160PR822 Devices to Read from Single EEPROM

8 Application and Implementation

注

Information in the following applications sections is not part of the TI component specification, and TI does not warrant its accuracy or completeness. TI's customers are responsible for determining suitability of components for their purposes. Customers should validate and test their design implementation to confirm system functionality.

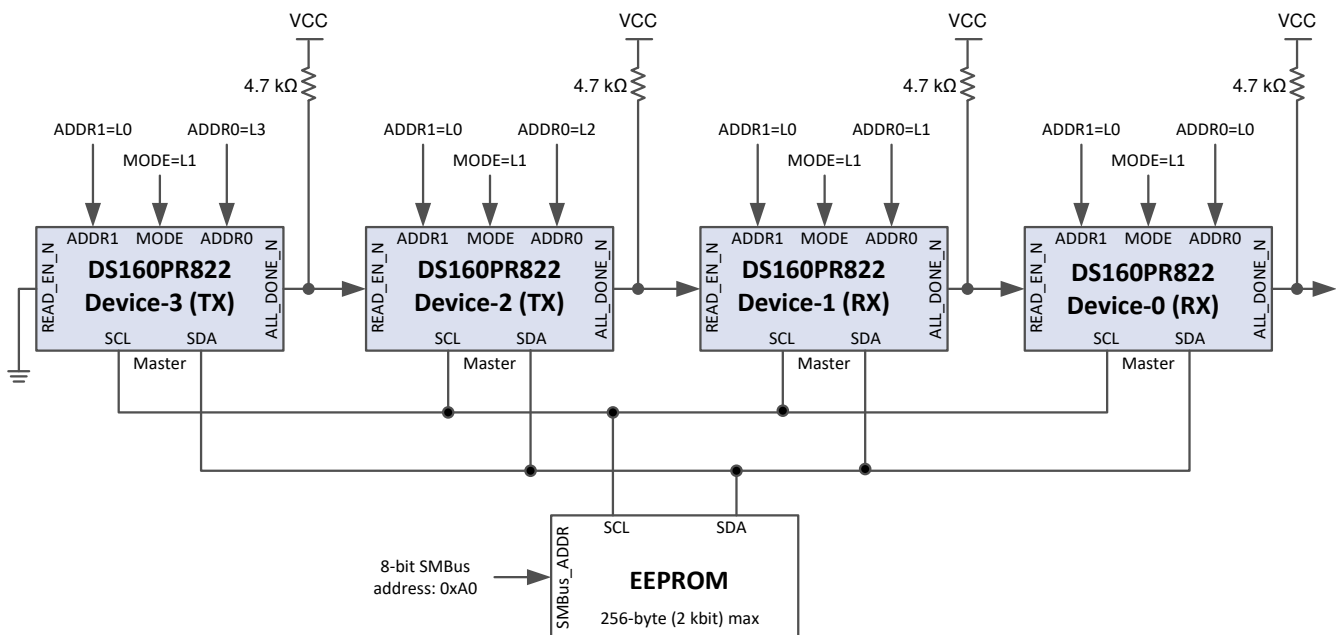
8.1 Application Information

The DS160PR822 is a high-speed linear repeater which extends the reach of differential channels impaired by loss from transmission media like PCBs and cables. It can be deployed in a variety of different systems. The following sections outline typical applications and their associated design considerations.

8.2 Typical Applications

The DS160PR822 is a protocol and interface agnostic linear redriver that can be used in wide range of interfaces including:

- PCI Express 1.0/2.0/3.0/4.0
- Ultra Path Interconnect (UPI) 1.0/2.0
- DisplayPort 2.0
- SAS
- SATA
- XFI

The DS160PR822 is a protocol agnostic linear redriver with PCI Express receiver-detect capability. Its protocol agnostic nature allows it to be used in PCI Express x4, x8, and x16 applications.  8-1 shows how eight DS160PR822 devices can be used to implement 2x2 crosspoint for x16 bus width to connect two CPUs to two EndPoints with flexibility.

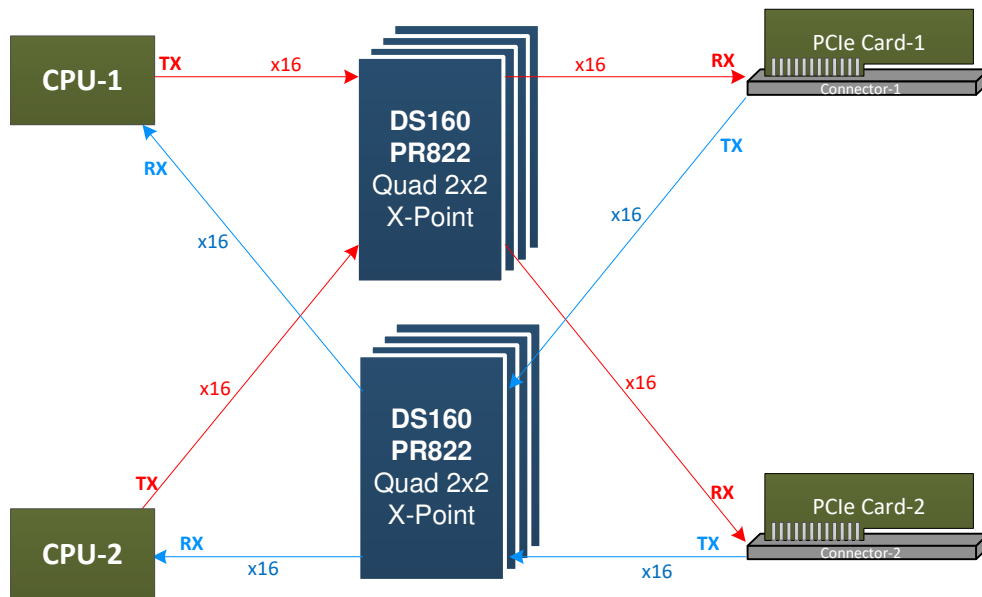

 8-1. 2x2 Cross point for x16 bus width using DS160PR822

8.2.1

The section outlines detailed procedure and design requirement for a typical . However, the design recommendations can be used in any lane configuration.

8.2.1.1 Design Requirements

As with any high-speed design, there are many factors which influence the overall performance. The following list indicates critical areas for consideration during design.

- Use 85 Ω impedance traces when interfacing with PCIe CEM connectors. Length matching on the P and N traces should be done on the single-end segments of the differential pair.
- Use a uniform trace width and trace spacing for differential pairs.
- Place AC-coupling capacitors near to the receiver end of each channel segment to minimize reflections.
- For PCIe Gen 3.0 and Gen 4.0, AC-coupling capacitors of 220 nF are recommended, set the maximum body size to 0402, and add a cutout void on the GND plane below the landing pad of the capacitor to reduce parasitic capacitance to GND.
- Back-drill connector vias and signal vias to minimize stub length.
- Use reference plane vias to ensure a low inductance path for the return current.

8.2.1.2 Detailed Design Procedure

In PCIe Gen 4.0 and Gen 3.0 applications, the specification requires Rx-Tx (of root-complex and endpoint) link training to establish and optimize signal conditioning settings at 16 Gbps and 8 Gbps, respectively. In link training, the Rx partner requests a series of FIR – preshoot and deemphasis coefficients (10 Presets) from the Tx partner. The Rx partner includes 7-levels (6 dB to 12 dB) of CTLE followed by a single tap DFE. The link training would pre-condition the signal, with an equalized link between the root-complex and endpoint resulting an optimized link. Note that there is no link training in PCIe Gen 1.0 (2.5 Gbps) or PCIe Gen 2.0 (5.0 Gbps) applications.

For operation in PCIe 4.0 or 3.0 links, the DS160PR822 is designed with linear datapath to pass the Tx preset signaling (by root complex and end point) onto the Rx (of root complex and end point) to train and optimize the equalization settings. The linear redriver device helps extend the PCB trace reach distance by boosting the attenuated signals with its equalization, which allows the user to recover the signal by the downstream Rx more easily. The device must be placed in between the Tx and Rx (of root complex and end point) such a way that both RX and TX signal swing stays within the linearity range of the device. Adjustments to the device EQ setting should be performed based on the channel loss to optimize the eye opening in the Rx partner. The available EQ gain settings are provided in [表 7-1](#). For most PCIe systems the default DC gain setting GAIN = floating would be sufficient.

The DS160PR822 can be optimized for a given system utilizing its three configuration modes - Pin Mode, SMBus/I²C Master Mode and SMBus/I²C Slave Mode. In SMBus/I²C modes the SCL, SDA pins must be pulled up to a 3.3 V supply with a pull-up resistor. The value of the resistor depends on total bus capacitance. 4.7 k Ω is a good first approximation for a bus capacitance of 10 pF.

8-2 shows a simplified schematic for lane configuration in SMBus/I²C Master Mode.

8-2. Simplified Schematic for Lane Configuration in SMBus/I²C Master Mode

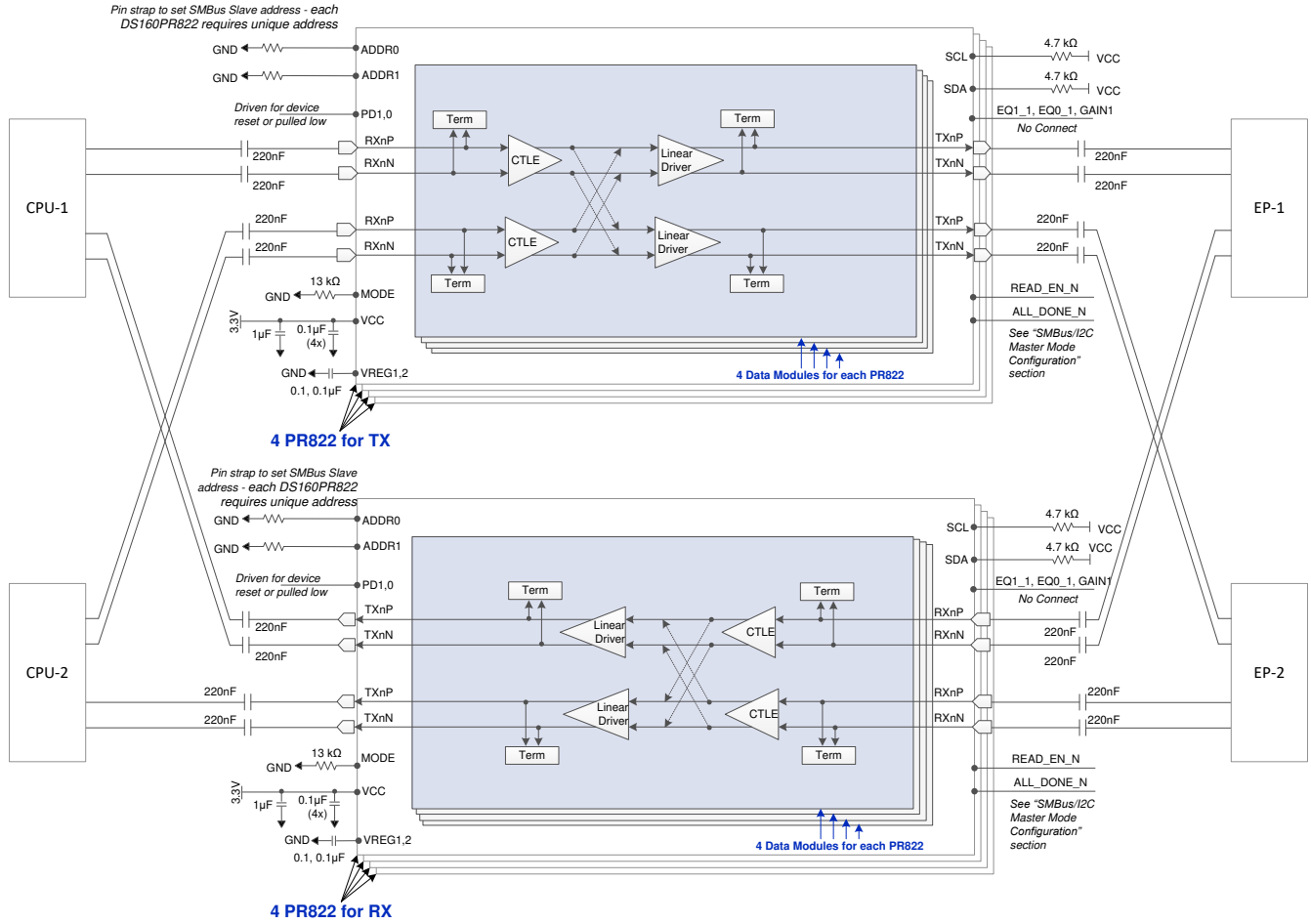

8-3. Simplified Schematic for Lane Configuration in SMBus/I²C Master Mode

8.2.1.3 Application Curves

The DS160PR822 is a linear redriver that can be used to extend channel reach of a PCIe link. Normally, PCIe-compliant TX and RX are equipped with signal-conditioning functions and can handle channel losses of up to 28 dB at 8 GHz. With the DS160PR822 in the link, the total channel loss between a PCIe root complex and an end point can be up to 42 dB at 8 GHz.

Figure 8-4 shows an electric link that models a single channel of a PCIe link and eye diagrams measured at different locations along the link. The source that models a PCIe TX sends a 16 Gbps PRBS-15 signal with P7 presets. After a transmission channel with -30 dB at 8 GHz insertion loss, the eye diagram is fully closed. The DS160PR822 with its CTLE set to the maximum (18 dB boost) together with the source TX equalization compensates for the losses of the pre-channel (TL1) and opens the eye at the output of the device.

The post-channel (TL2) losses mandate the use of PCIe RX equalization functions such as CTLE and DFE that are normally available in PCIe-compliant receivers.

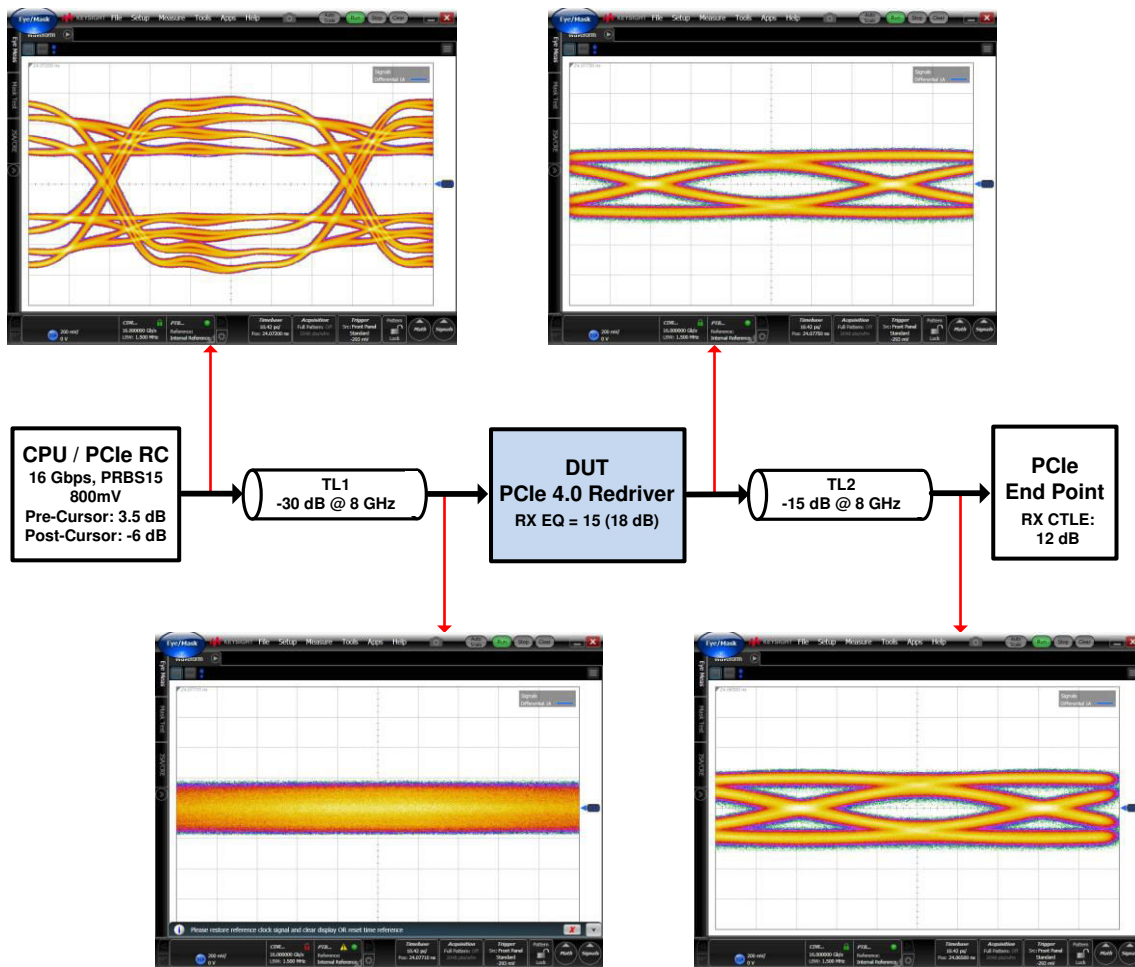

Figure 8-4. PCIe 4.0 Link Reach Extension Using DS160PR822

9 Power Supply Recommendations

Follow these general guidelines when designing the power supply:

1. The power supply should be designed to provide the operating conditions outlined in the recommended operating conditions section in terms of DC voltage, AC noise, and start-up ramp time.
2. The DS160PR822 does not require any special power supply filtering, such as ferrite beads, provided that the recommended operating conditions are met. Only standard supply decoupling is required. Typical supply decoupling consists of a 0.1 μF capacitor per VCC pin, one 1.0 μF bulk capacitor per device, and one 10 μF bulk capacitor per power bus that delivers power to one or more devices. The local decoupling (0.1 μF) capacitors must be connected as close to the VCC pins as possible and with minimal path to the device ground pad.
3. The DS160PR822 voltage regulator output pins require decoupling caps of 0.1 μF near each pins. The regulator is only for internal use. Do not use to provide power to any external component.

10 Layout

10.1 Layout Guidelines

The following guidelines should be followed when designing the layout:

1. Decoupling capacitors should be placed as close to the VCC pins as possible. Placing the decoupling capacitors directly underneath the device is recommended if the board design permits.
2. High-speed differential signals TXnP/TXnN and RXnP/RXnN should be tightly coupled, skew matched, and impedance controlled.
3. Vias should be avoided when possible on the high-speed differential signals. When vias must be used, take care to minimize the via stub, either by transitioning through most/all layers or by back drilling.
4. GND relief can be used (but is not required) beneath the high-speed differential signal pads to improve signal integrity by counteracting the pad capacitance.
5. GND vias should be placed directly beneath the device connecting the GND plane attached to the device to the GND planes on other layers. This has the added benefit of improving thermal conductivity from the device to the board.

10.2 Layout Example

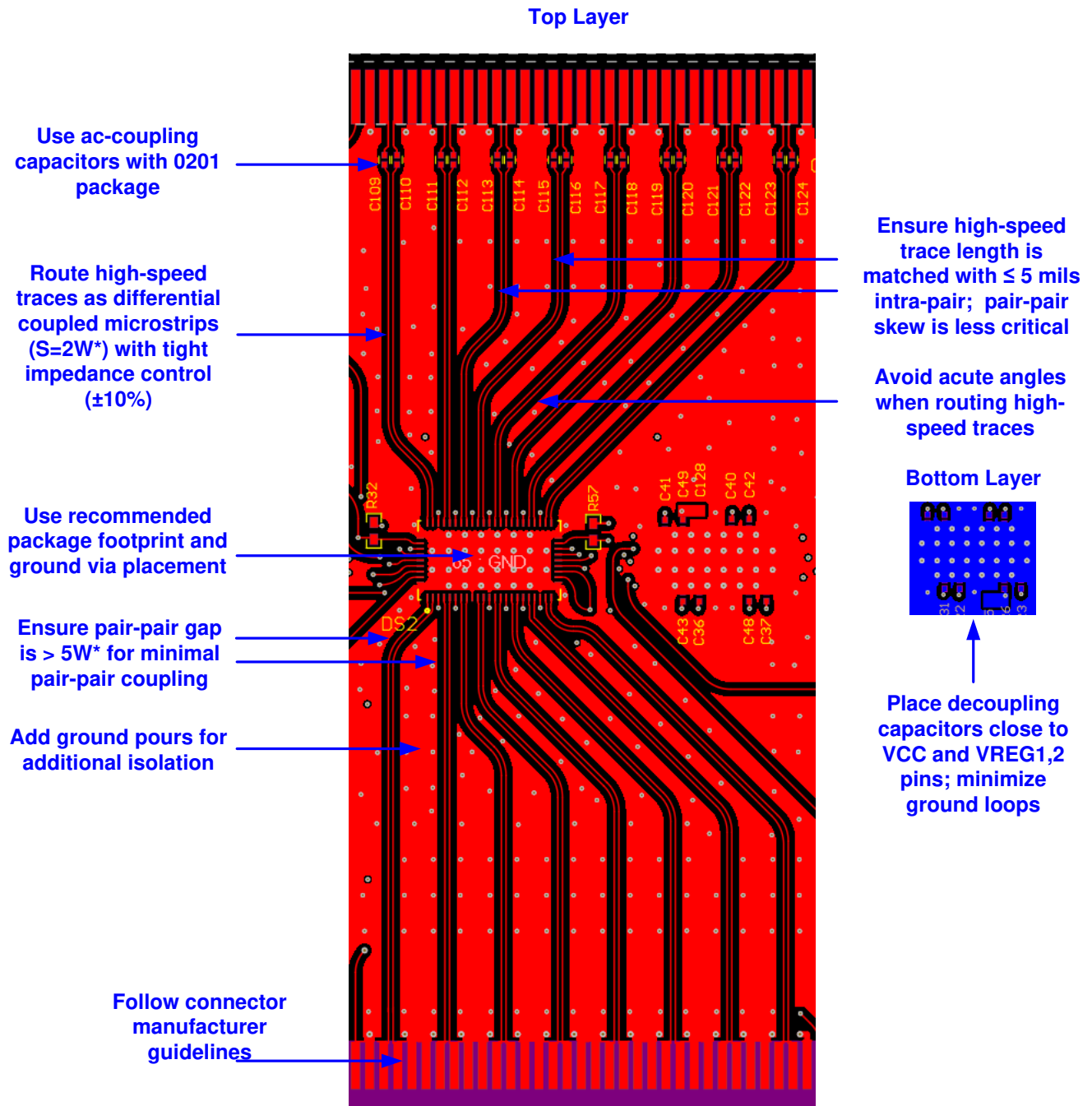

*W is a trace width. S is a gap between adjacent traces.

10-1. DS160PR822 Layout Example - Sub-Section of a PCIe Riser Card With CEM Connectors

11 Device and Documentation Support

11.1 Receiving Notification of Documentation Updates

To receive notification of documentation updates, navigate to the device product folder on ti.com. In the upper right corner, click on *Alert me* to register and receive a weekly digest of any product information that has changed. For change details, review the revision history included in any revised document.

11.2 Community Resources

11.3 Trademarks

すべての商標は、それぞれの所有者に帰属します。

12 Mechanical, Packaging, and Orderable Information

The following pages include mechanical, packaging, and orderable information. This information is the most current data available for the designated devices. This data is subject to change without notice and revision of this document. For browser-based versions of this data sheet, refer to the left-hand navigation.

PACKAGING INFORMATION

Orderable part number	Status (1)	Material type (2)	Package Pins	Package qty Carrier	RoHS (3)	Lead finish/ Ball material (4)	MSL rating/ Peak reflow (5)	Op temp (°C)	Part marking (6)
DS160PR822NJXR	Active	Production	WQFN (NJX) 64	3000 LARGE T&R	Yes	NIPDAU	Level-2-260C-1 YEAR	-40 to 85	PR8XX
DS160PR822NJXR.B	Active	Production	WQFN (NJX) 64	3000 LARGE T&R	-	Call TI	Call TI	-40 to 85	
DS160PR822NJXT	Active	Production	WQFN (NJX) 64	250 SMALL T&R	Yes	NIPDAU	Level-2-260C-1 YEAR	-40 to 85	PR8XX
DS160PR822NJXT.B	Active	Production	WQFN (NJX) 64	250 SMALL T&R	-	Call TI	Call TI	-40 to 85	
DS160PR822NJXTG4	Active	Production	WQFN (NJX) 64	250 SMALL T&R	Yes	NIPDAU	Level-2-260C-1 YEAR	-40 to 85	PR8XX
DS160PR822NJXTG4.B	Active	Production	WQFN (NJX) 64	250 SMALL T&R	-	Call TI	Call TI	-40 to 85	

⁽¹⁾ **Status:** For more details on status, see our [product life cycle](#).

⁽²⁾ **Material type:** When designated, preproduction parts are prototypes/experimental devices, and are not yet approved or released for full production. Testing and final process, including without limitation quality assurance, reliability performance testing, and/or process qualification, may not yet be complete, and this item is subject to further changes or possible discontinuation. If available for ordering, purchases will be subject to an additional waiver at checkout, and are intended for early internal evaluation purposes only. These items are sold without warranties of any kind.

⁽³⁾ **RoHS values:** Yes, No, RoHS Exempt. See the [TI RoHS Statement](#) for additional information and value definition.

⁽⁴⁾ **Lead finish/Ball material:** Parts may have multiple material finish options. Finish options are separated by a vertical ruled line. Lead finish/Ball material values may wrap to two lines if the finish value exceeds the maximum column width.

⁽⁵⁾ **MSL rating/Peak reflow:** The moisture sensitivity level ratings and peak solder (reflow) temperatures. In the event that a part has multiple moisture sensitivity ratings, only the lowest level per JEDEC standards is shown. Refer to the shipping label for the actual reflow temperature that will be used to mount the part to the printed circuit board.

⁽⁶⁾ **Part marking:** There may be an additional marking, which relates to the logo, the lot trace code information, or the environmental category of the part.

Multiple part markings will be inside parentheses. Only one part marking contained in parentheses and separated by a "~" will appear on a part. If a line is indented then it is a continuation of the previous line and the two combined represent the entire part marking for that device.

Important Information and Disclaimer: The information provided on this page represents TI's knowledge and belief as of the date that it is provided. TI bases its knowledge and belief on information provided by third parties, and makes no representation or warranty as to the accuracy of such information. Efforts are underway to better integrate information from third parties. TI has taken and continues to take reasonable steps to provide representative and accurate information but may not have conducted destructive testing or chemical analysis on incoming materials and chemicals. TI and TI suppliers consider certain information to be proprietary, and thus CAS numbers and other limited information may not be available for release.

In no event shall TI's liability arising out of such information exceed the total purchase price of the TI part(s) at issue in this document sold by TI to Customer on an annual basis.

NJX0064A

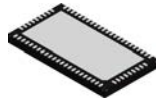

PACKAGE OUTLINE

WQFN - 0.8 mm max height

PLASTIC QUAD FLATPACK - NO LEAD

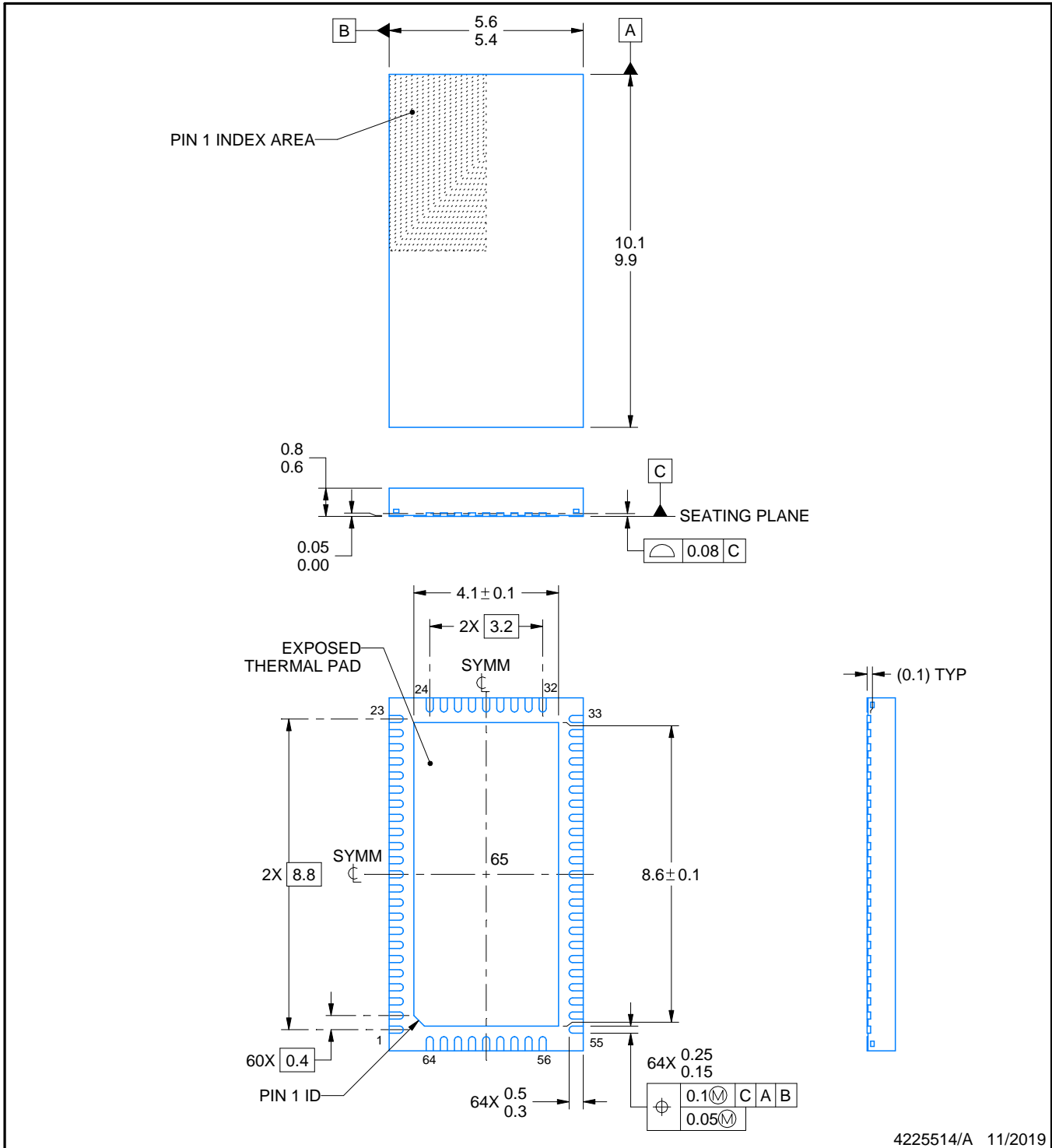

4225514/A 11/2019

NOTES:

1. All linear dimensions are in millimeters. Any dimensions in parenthesis are for reference only. Dimensioning and tolerancing per ASME Y14.5M.
2. This drawing is subject to change without notice.
3. The package thermal pad must be soldered to the printed circuit board for thermal and mechanical performance.

EXAMPLE BOARD LAYOUT

NJX0064A

WQFN - 0.8 mm max height

PLASTIC QUAD FLATPACK - NO LEAD

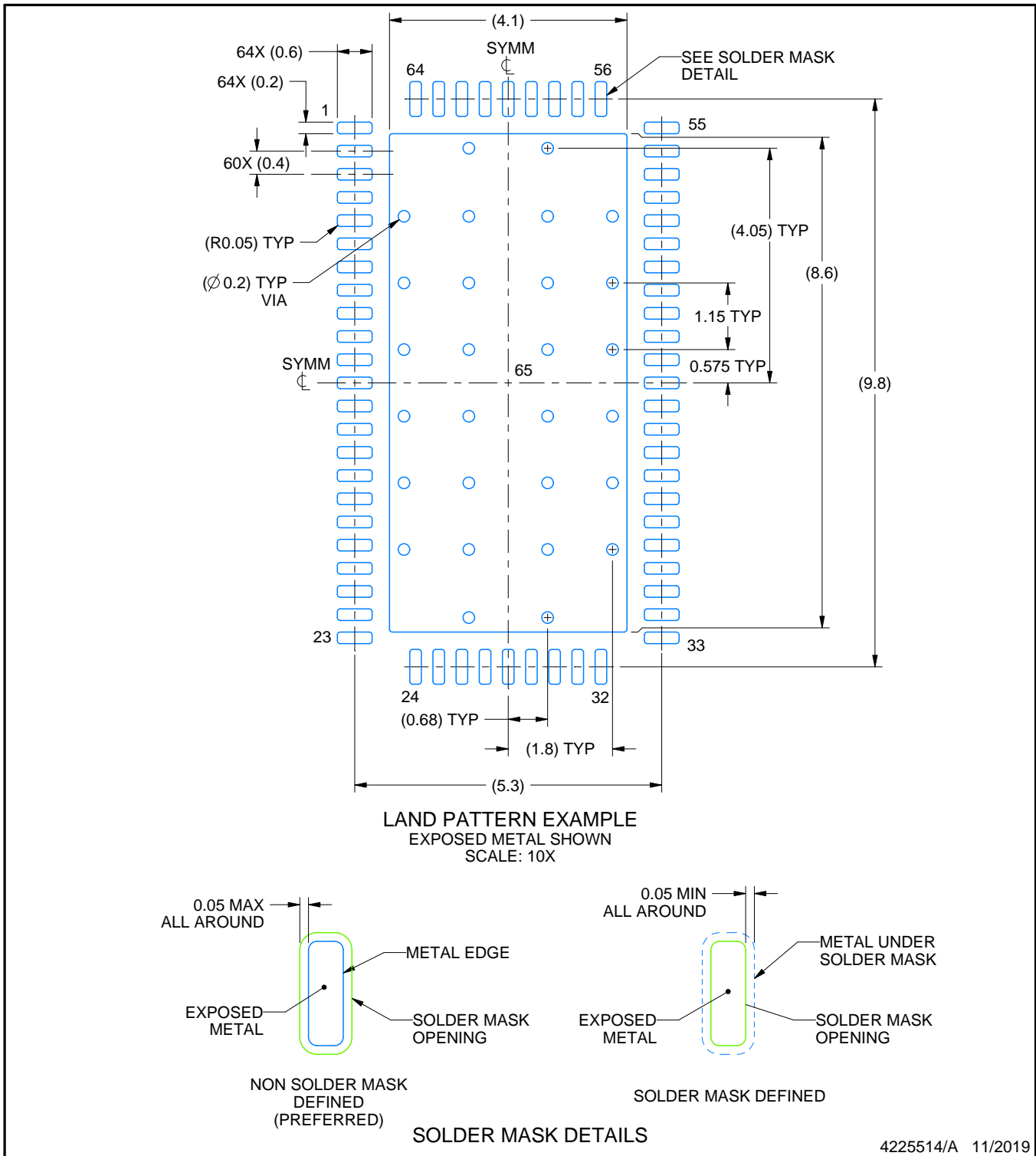

NOTES: (continued)

4. This package is designed to be soldered to a thermal pad on the board. For more information, see Texas Instruments literature number SLUA271 (www.ti.com/lit/slua271).
5. Vias are optional depending on application, refer to device data sheet. If any vias are implemented, refer to their locations shown on this view. It is recommended that vias under paste be filled, plugged or tented.

EXAMPLE STENCIL DESIGN

NJX0064A

WQFN - 0.8 mm max height

PLASTIC QUAD FLATPACK - NO LEAD

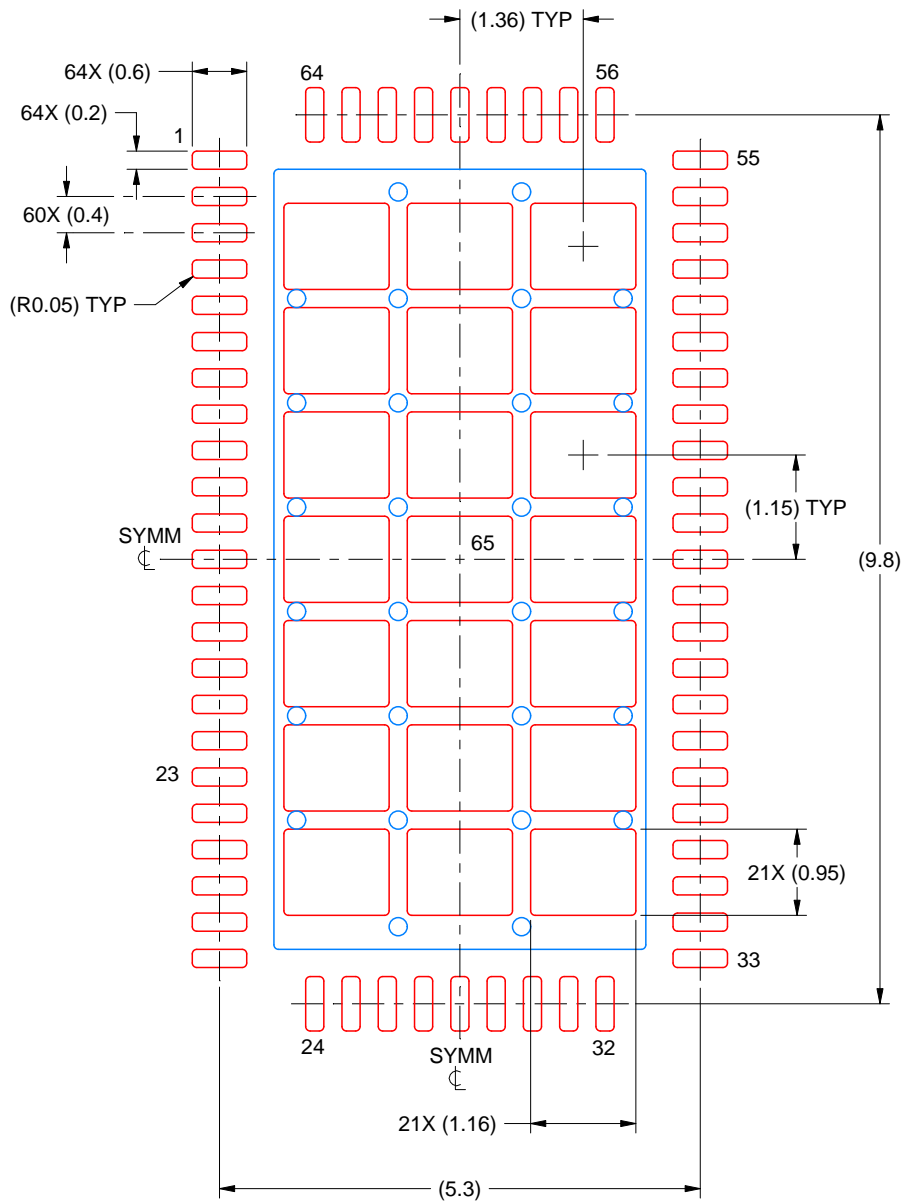

SOLDER PASTE EXAMPLE
BASED ON 0.125 MM THICK STENCIL
SCALE: 12X

EXPOSED PAD 65
66% PRINTED SOLDER COVERAGE BY AREA UNDER PACKAGE

4225514/A 11/2019

NOTES: (continued)

6. Laser cutting apertures with trapezoidal walls and rounded corners may offer better paste release. IPC-7525 may have alternate design recommendations.

重要なお知らせと免責事項

TI は、技術データと信頼性データ(データシートを含みます)、設計リソース(リファレンス デザインを含みます)、アプリケーションや設計に関する各種アドバイス、Web ツール、安全性情報、その他のリソースを、欠陥が存在する可能性のある「現状のまま」提供しており、商品性および特定目的に対する適合性の黙示保証、第三者の知的財産権の非侵害保証を含むいかなる保証も、明示的または黙示的にかかわらず拒否します。

これらのリソースは、TI 製品を使用する設計の経験を積んだ開発者への提供を意図したものです。(1) お客様のアプリケーションに適した TI 製品の選定、(2) お客様のアプリケーションの設計、検証、試験、(3) お客様のアプリケーションに該当する各種規格や、その他のあらゆる安全性、セキュリティ、規制、または他の要件への確実な適合に関する責任を、お客様のみが単独で負うものとし、

上記の各種リソースは、予告なく変更される可能性があります。これらのリソースは、リソースで説明されている TI 製品を使用するアプリケーションの開発の目的でのみ、TI はその使用をお客様に許諾します。これらのリソースに関して、他の目的で複製することや掲載することは禁止されています。TI や第三者の知的財産権のライセンスが付与されている訳ではありません。お客様は、これらのリソースを自身で使用した結果発生するあらゆる申し立て、損害、費用、損失、責任について、TI およびその代理人を完全に補償するものとし、TI は一切の責任を拒否します。

TI の製品は、[TI の販売条件](#)、[TI の総合的な品質ガイドライン](#)、[ti.com](#) または TI 製品などに関連して提供される他の適用条件に従い提供されます。TI がこれらのリソースを提供することは、適用される TI の保証または他の保証の放棄の拡大や変更を意味するものではありません。TI がカスタム、またはカスタマー仕様として明示的に指定していない限り、TI の製品は標準的なカタログに掲載される汎用機器です。

お客様がいかなる追加条項または代替条項を提案する場合も、TI はそれらに異議を唱え、拒否します。

Copyright © 2025, Texas Instruments Incorporated

最終更新日：2025 年 10 月