

BQ25300 スタンドアロン1セル、17V、3.0A バッテリー・チャージャ

1 特長

- スタンドアロン・チャージャと構成が容易
- 高効率 1.2MHz 同期整流スイッチモード降圧充電器
 - 1セル・バッテリーの場合 5V 入力から 2A で 92.5% の充電効率
 - 1セル・バッテリーの場合 9V 入力から 2A で 91.8% の充電効率
- 1つの入力で USB 入力および高電圧アダプタに対応
 - 4.1V~17V 入力電圧範囲に対応、入力電圧の絶対最大定格 28V
 - 入力電圧のダイナミック・パワー・マネージメント (VINDPM) によるバッテリー電圧トラッキング
- 高集積
 - 逆方向ブロッキングと同期スイッチング MOSFET を内蔵
 - 内部入力および充電電流センス
 - ループ補償内蔵
 - ブートストラップ・ダイオードを内蔵
- 3.6V/4.05V/4.15V/4.2V の充電電圧
- 3.0A の最大高速充電電流
- 4.5V V_{BAT} で 200nA の低バッテリー・リーク電流
- IC ディスエーブル・モードで 4.25 μ A の VBUS 消費電流
- 120°Cでの充電電流の熱レギュレーション
- プリチャージ電流: 高速充電電流の 10%
- 終了電流: 高速充電電流の 10%
- 充電精度
 - $\pm 0.5\%$ の充電電圧レギュレーション
 - $\pm 10\%$ の充電電流レギュレーション
- 安全性
 - サーマル・レギュレーションおよびサーマル・シャットダウン
 - 入力低電圧誤動作防止 (UVLO) および過電圧保護 (OVP)
 - バッテリー過充電保護
 - プリチャージおよび高速充電用の安全タイマ
 - 電流設定ピン ICHG が断線または短絡している場合、充電はディスエーブルになります
 - 低温 / 高温バッテリー温度保護
 - STAT ピンでの異常検出出力
- WQFN 3x3-16 パッケージで供給

2 アプリケーション

- ワイヤレス・スピーカー
- バーコード・スキャナー
- ゲーム
- スタンド型充電器
- コードレス電動工具
- ビル・オートメーション
- 医療用

3 概要

BQ25300 は、1セル・リチウムイオンおよびリチウムポリマ、および LiFePO4 バッテリー用の高集積スタンドアロン・スイッチモード・バッテリー・チャージャです。BQ25300 は、4.1V~17V の入力電圧と 3A の高速充電電流に対応しています。このデバイスには電流センシング・トポロジが内蔵されているため、高い充電効率と低い BOM コストを実現できます。クラス最高の 200nA 低静止電流を実現したこのデバイスは、バッテリーのエネルギーを節約し、ポータブル・デバイスの保管時間を最大化します。BQ25300 は、3x3 WQFN パッケージで供給されるため、2層レイアウトが簡単で、スペースに制約のあるアプリケーションに適しています。

製品情報

部品番号 (1)	パッケージ	本体サイズ (公称)
BQ25300	RTE (WQFN)	3.00mm x 3.00mm

- (1) 利用可能なパッケージについては、このデータシートの末尾にある注文情報を参照してください。

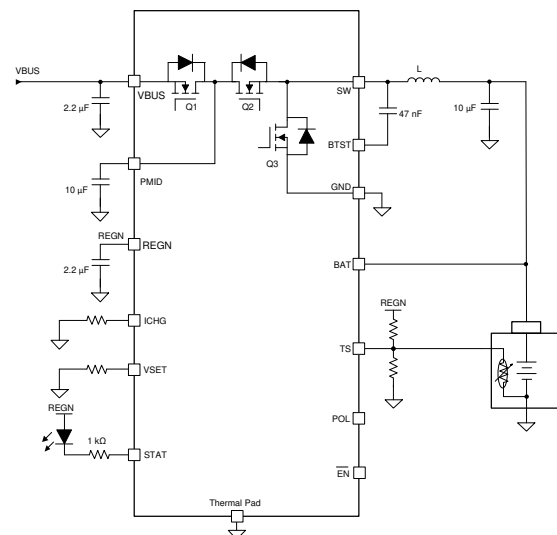

簡略化されたアプリケーション



Table of Contents

1 特長	1	9.3 Feature Description.....	15
2 アプリケーション	1	9.4 Device Functional Modes.....	19
3 概要	1	10 Application and Implementation	20
4 Revision History	2	10.1 Application Information.....	20
5 概要 (続き)	3	10.2 Typical Applications.....	20
6 Device Comparison Table	4	11 Power Supply Recommendations	26
7 Pin Configuration and Functions	5	12 Layout	27
8 Specifications	7	12.1 Layout Guidelines.....	27
8.1 Absolute Maximum Ratings.....	7	12.2 Layout Example.....	27
8.2 ESD Ratings.....	7	13 Device and Documentation Support	29
8.3 Recommended Operating Conditions.....	7	13.1 Device Support.....	29
8.4 Thermal Information.....	8	13.2 ドキュメントの更新通知を受け取る方法.....	29
8.5 Electrical Characteristics.....	8	13.3 サポート・リソース.....	29
8.6 Timing Requirements.....	10	13.4 Trademarks.....	29
8.7 Typical Characteristics.....	12	13.5 静電気放電に関する注意事項.....	29
9 Detailed Description	13	13.6 用語集.....	29
9.1 Overview.....	13	14 Mechanical, Packaging, and Orderable Information	30
9.2 Functional Block Diagram.....	14		

4 Revision History

DATE	REVISION	NOTES
February 2021	*	Initial Release

5 概要 (続き)

BQ25300 は 4.1V~17V の入力をサポートしており、シングル・セル・バッテリーを充電します。BQ25300 は シングル・セル 1S バッテリー に最大 3A の連続充電電流を供給しますこのデバイスは、ポータブル・デバイス用の高速充電を特長としています。入力電圧レギュレーションにより、入力電源からバッテリーに最大の充電電力を供給します。このソリューションは、入力逆方向ブロッキング FET (RBFET、Q1)、ハイサイド・スイッチング FET (HSFET、Q2)、ローサイド・スイッチング FET (LSFET、Q3) と高度に統合されています。

BQ25300 は、ロスレスの内蔵電流センシング機能を搭載しており、部品点数を最小限に抑えて電力損失と BOM コストを低減します。また、ハイサイド・ゲート・ドライブおよびバッテリー温度監視用のブートストラップ・ダイオードが内蔵されているため、システム設計を簡素化できます。このデバイスは、ホスト制御なしで、充電サイクルの開始から完了までを実行できます。BQ25300 の充電電圧と充電電流は、外付け抵抗で設定されます。BQ25300 はスタートアップ時の充電電圧設定を検出し、バッテリー短絡、プリコンディショニング、定電流、定電圧という 4 つのフェーズでバッテリーを充電します。充電サイクルの終わりに、充電電流が終端電流のスレッシュホールドを下回り、かつバッテリー電圧が再充電スレッシュホールドを上回ると、充電器は自動的に処理を終了します。バッテリー電圧が再充電スレッシュホールドを下回ると、充電器は自動的にまた充電サイクルを開始します。この充電器は、負の温度係数 (NTC) サーミスタに基づくバッテリー温度監視、充電安全タイマ、入力過電圧および過電流保護、バッテリー過電圧保護など、バッテリー充電とシステム動作のためのさまざまな安全機能を備えています。ピンの断線および短絡保護も内蔵されており、充電電流設定ピン ICHG が誤って断線または GND へ短絡した場合に保護されます。サーマル・レギュレーションにより充電電流が制御され、大電力動作時や高い周囲温度条件時にダイの温度が制限されます。

STAT ピン出力により、充電状態とフォルト状態がレポートされます。入力電圧が除去されると、デバイスは自動的に HiZ モードに移行し、バッテリーから充電器デバイスへのリーク電流が非常に低くなります。BQ25300 は 3mm × 3mm の薄型 WQFN パッケージで供給されます。

6 Device Comparison Table

	BQ25300	BQ25302	BQ25303J	BQ25306
Battery Cells in Series	1	1	1	1, 2
Input Operation Voltage	4.1V to 17V	4.1V to 6.2V	4.1V to 17V	4.1V to 17V
Charge Voltage	3.6V, 4.15V, 4.2V, 4.05V	4.1V, 4.35V, 4.4V, 4.2V	4.1V, 4.35V, 4.4V, 4.2V	programmable from 3.4V to 9.0V
Maximum Fast Charge Current ICHG	3.0A	2.0A	3.0A	3.0A
Battery Temperature Protection (JEITA or Cold/Hot)	Cold/Hot	Cold/Hot	JEITA	Cold/Hot

7 Pin Configuration and Functions



图 7-1. RTE Package 16-Pin WQFN Top View

表 7-1. Pin Functions

PIN		I/O ⁽¹⁾	DESCRIPTION
NAME	NO.		
VBUS	1	P	Charger input voltage. The internal n-channel reverse block MOSFET (RBFET) is connected between VBUS and PMID with VBUS on source. Place a 2.2µF ceramic capacitor from VBUS to GND and place it as close as possible to IC.
PMID	16	P	Connected to the drain of the reverse blocking MOSFET (RBFET) and the drain of high-side MOSFET (HSFET). Place ceramic 10µF on PMID to GND and place it as close as possible to IC.
SW	13,14	P	Switching node. Connected to output inductor. Internally SW is connected to the source of the n-channel HSFET and the drain of the n-channel LSFET. Connect the 0.047µF bootstrap capacitor from SW to BTST.
BTST	15	P	High-side FET driver supply. Internally, the BTST is connected to the cathode of the internal boost-strap diode. Connect the 0.047µF bootstrap capacitor from SW to BTST.
GND	11,12	P	Ground. Connected directly to thermal pad on the top layer. A single point connection is recommended between power ground and analog ground near the IC GND pins.
REGN	2	P	Low-side FET driver positive supply output. Connect a 2.2µF ceramic capacitor from REGN to GND. The capacitor should be placed close to the IC.
BAT	10	AI	Battery voltage sensing input. Connect this pin to the positive terminal of the battery pack and the node of inductor output terminal. 10-µF capacitor is recommended to connect to this pin.
TS	7	AI	Battery temperature voltage input. Connect a negative temperature coefficient thermistor (NTC). Program temperature window with a resistor divider from REGN to TS and TS to GND. Charge suspends when TS pin voltage is out of range. When TS pin is not used, connect a 10-kΩ resistor from REGN to TS and a 10-kΩ resistor from TS to GND. It is recommended to use a 103AT-2 thermistor.
ICHG	4	AI	Charge current program input. Connect a 1% resistor R _{ICHG} from this pin to ground to program the charge current as $ICHG = K_{ICHG} / R_{ICHG}$ ($K_{ICHG} = 40,000$). No capacitor is allowed to connect at this pin. When ICHG pin is pulled to ground or left open, the charger stop switching and STAT pin starts blinking.
STAT	3	AO	Charge status indication output. This pin is open drain output. Connect this pin to REGN via a current limiting resistor and LED. The STAT pin indicates charger status as: <ul style="list-style-type: none"> • Charge in progress: STAT pin is pulled LOW • Charge completed, charge disabled by EN: STAT pin is OPEN • Fault conditions: STAT pin blinks.
VSET	9	AI	Charge voltage setting input. VSET pin sets battery charge voltage. Program battery regulation voltage with a resistor pull-down from VSET to GND as: <ul style="list-style-type: none"> • Floating ($R > 200k\Omega \pm 10\%$): 3.6V • Shorted to GND ($R < 510\Omega$): 4.05V • $R = 51k\Omega \pm 10\%$: 4.15V • $R = 10k\Omega \pm 10\%$: 4.2V The maximum allowed capacitance on this pin is 50pF.

表 7-1. Pin Functions (continued)

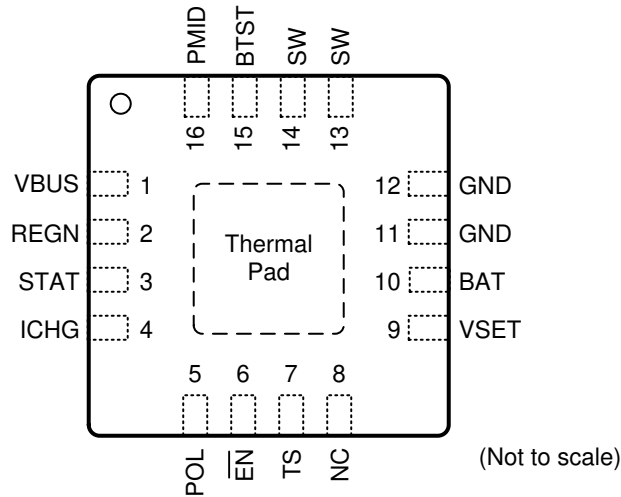
PIN		I/O ⁽¹⁾	DESCRIPTION
NAME	NO.		
POL	5	AI	$\overline{\text{EN}}$ pin polarity selection.
$\overline{\text{EN}}$	6	AI	Device disable input. With POL pin floating, the device is enabled with $\overline{\text{EN}}$ pin floating or pulled low, and the device is disabled if $\overline{\text{EN}}$ pin is pulled high. With POL pin grounded, the device is enabled with $\overline{\text{EN}}$ pin pulled high, and the device is disabled with $\overline{\text{EN}}$ pin pulled low or floating.
NC	8	-	No connection. Keep this pin floating or grounded.
Thermal Pad	17	-	Ground reference for the device that is also the thermal pad used to conduct heat from the device. This connection serves two purposes. The first purpose is to provide an electrical ground connection for the device. The second purpose is to provide a low thermal-impedance path from the device die to the PCB. This pad should be tied externally to a ground plane. Ground layer(s) are connected to thermal pad through vias under thermal pad.

(1) AI = Analog input, AO = Analog Output, AIO = Analog input Output, DI = Digital input, DO = Digital Output, DIO = Digital input Output, P = Power

8 Specifications

8.1 Absolute Maximum Ratings

Over operating free-air temperature range (unless otherwise noted)⁽¹⁾

PARAMETER		MIN	MAX	UNIT
Voltage Range (with respect to GND)	V _{BUS} (converter not switching)	-2	28	V
	P _{MID} (converter not switching)	-0.3	28	V
	SW	-2(-3 for 10ns)	20	V
	BTST	-0.3	25.5	V
	BAT	-0.3	11	V
	REGN	-0.3	5.5	V
	VSET	-0.3	11	V
	ICHG, REGN, TS, STAT, POL, EN	-0.3	5.5	V
Voltage Range	BTST to SW	-0.3	5.5	V
Output Sink Current	STAT		6	mA
Output Sink Current	REGN		16	mA
Operating junction temperature, T _J		-40	150	°C
Storage temperature, T _{stg}		-65	150	°C

- (1) Stresses beyond those listed under Absolute maximum Ratings may cause permanent damage to the device. These are stress ratings only, which do not imply functional operation of the device at these or any other conditions beyond those indicated under Recommended Operating Conditions. Exposure to absolute-maximum-rated conditions for extended periods may affect device reliability. All voltage values are with respect to the network ground terminal unless otherwise noted.

8.2 ESD Ratings

			VALUE	UNIT
V _(ESD)	Electrostatic discharge	Human body model (HBM), per ANSI/ESDA/ JEDEC JS-001, all pins ⁽¹⁾	±2000	V
		Charged device model (CDM), per JEDEC specification JESD22-C101, all pins ⁽²⁾	±250	

- (1) JEDEC document JEP155 states that 500-V HBM allows safe manufacturing with a standard ESD control process.
 (2) JEDEC document JEP157 states that 250-V CDM allows safe manufacturing with a standard ESD control process.

8.3 Recommended Operating Conditions

over operating free-air temperature range (unless otherwise noted)

PARAMETER		MIN	NOM	MAX	UNIT
V _{BUS}	Input voltage	4.1		17	V
V _{BAT}	Battery voltage			4.2	V
I _{VBUS}	Input current			3	A
I _{SW}	Output current (SW)			3	A
T _A	Ambient temperature	-40		85	°C
L	Recommended inductance at V _{BUS_MAX} < 6.2V		1.0		μH
L	Recommended inductance at V _{BUS_MAX} > 6.2V		2.2		μH
C _{VBUS}	Recommended capacitance at V _{BUS}		2.2		μF
C _{PMID}	Recommended capacitance at P _{MID}		10		μF
C _{BAT}	Recommended capacitance at BAT		10		μF

8.4 Thermal Information

THERMAL METRIC ⁽¹⁾		BQ2530x	UNIT
		RTE	
		16-PINS	
$R_{\theta JA}$	Junction-to-ambient thermal resistance (JEDEC ⁽¹⁾)	45.8	°C/W
$R_{\theta JC(top)}$	Junction-to-case (top) thermal resistance	48.5	°C/W
$R_{\theta JB}$	Junction-to-board thermal resistance	19.0	°C/W
Ψ_{JT}	Junction-to-top characterization parameter	1.3	°C/W
Ψ_{JB}	Junction-to-board characterization parameter	19	°C/W
$R_{\theta JC(bot)}$	Junction-to-case (bottom) thermal resistance	7.9	°C/W

(1) For more information about traditional and new thermal metrics, see the [Semiconductor and IC Package Thermal Metrics](#) application report.

8.5 Electrical Characteristics

$V_{VBUS_UVLOZ} < V_{VBUS} < V_{VBUS_OVP}$ and $V_{VBUS} > V_{BAT} + V_{SLEEP}$, $L=2.2\mu H$, $T_J = -40^{\circ}C$ to $+125^{\circ}C$, and $T_J = 25^{\circ}C$ for typical values (unless otherwise noted)

PARAMETER		TEST CONDITIONS	MIN	TYP	MAX	UNIT
QUIESCENT CURRENT						
I_{VBUS_REVS}	V_{BUS} reverse current from BAT/SW to V_{BUS} $T_J = -40^{\circ}C - 85^{\circ}C$	$V_{BAT} = V_{SW} = 4.5V$, V_{BUS} is shorted to GND, measure V_{BUS} reverse current		0.07	3	μA
$I_{Q_VBUS_DIS}$	V_{BUS} leakage current in disable mode $T_J = -40^{\circ}C - 85^{\circ}C$	$V_{BUS} = 5V$, $V_{BAT} = 4V$, charger is disabled, /EN is pulled high		3.5	4.25	μA
$I_{Q_BAT_HIZ}$	BAT and SW pin leakage current in HiZ mode $T_J = -40^{\circ}C - 65^{\circ}C$	$V_{BAT} = V_{SW} = 4.5V$, V_{BUS} floating		0.17	1	μA
VBUS POWER UP						
V_{VBUS_OP}	V_{BUS} operating range		4.1		17.0	V
V_{VBUS_UVLOZ}	V_{BUS} power on reset	V_{BUS} rising	3.0		3.80	V
$V_{VBUS_UVLOZ_HYS}$	V_{BUS} power on reset hysteresis	V_{BUS} falling		250		mV
V_{VBUS_LOWV}	A condition to turnon REGN	V_{BUS} rising, REGN turns on, $V_{BAT} = 3.2V$	3.8	3.90	4.00	V
$V_{VBUS_LOWV_HYS}$	A condition to turnon REGN, hysteresis	V_{BUS} falling, REGN turns off, $V_{BAT} = 3.2V$		300		mV
V_{SLEEP}	Enter sleep mode threshold	V_{BUS} falling, $V_{BUS} - V_{BAT}$, $V_{VBUS_LOWV} < V_{BAT} < V_{BATREG}$	30	60	100	mV
V_{SLEEPZ}	Exit sleep mode threshold	V_{BUS} rising, $V_{BUS} - V_{BAT}$, $V_{VBUS_LOWV} < V_{BAT} < V_{BATREG}$	110	157	295	mV
$V_{VBUS_OVP_RISE}$	V_{BUS} overvoltage rising threshold	V_{BUS} rising, converter stops switching	17.00	17.40	17.80	V
$V_{VBUS_OVP_HYS}$	V_{BUS} overvoltage falling hysteresis	V_{BUS} falling, converter stops switching		750		mV
MOSFETS						
R_{DSON_Q1}	Top reverse blocking MOSFET on-resistance between V_{BUS} and PMID (Q1)	$V_{REGN} = 5V$		40	65	m Ω
R_{DSON_Q2}	High-side switching MOSFET on-resistance between PMID and SW (Q2)	$V_{REGN} = 5V$		50	82	m Ω
R_{DSON_Q3}	Low-side switching MOSFET on-resistance between SW and GND (Q3)	$V_{REGN} = 5V$		45	72	m Ω
BATTERY CHARGER						

8.5 Electrical Characteristics (continued)

$V_{VBUS_UVLOZ} < V_{VBUS} < V_{VBUS_OVP}$ and $V_{VBUS} > V_{BAT} + V_{SLEEP}$, $L=2.2\mu\text{H}$, $T_J = -40^\circ\text{C}$ to $+125^\circ\text{C}$, and $T_J = 25^\circ\text{C}$ for typical values (unless otherwise noted)

PARAMETER		TEST CONDITIONS	MIN	TYP	MAX	UNIT
V_{BATREG}	Charge voltage regulation	VSET pin floating, $T_J = -40^\circ\text{C}$ to $+85^\circ\text{C}$	3.582	3.6	3.618	V
		Connect VSET pin to 51k Ω resistor, $T_J = -40^\circ\text{C}$ to $+85^\circ\text{C}$	4.13	4.15	4.170	V
		Connect VSET pin to 10k Ω resistor, $T_J = -40^\circ\text{C}$ to $+85^\circ\text{C}$	4.179	4.200	4.221	V
		VSET pin is grounded, $T_J = -40^\circ\text{C}$ to $+85^\circ\text{C}$	4.03	4.050	4.070	V
I_{CHG}	Charge current regulation	ICHG set at 1.72A with $R_{ICHG} = 23.2\text{k}\Omega$	1.55	1.72	1.89	A
		ICHG set at 1.0A with $R_{ICHG} = 40.2\text{k}\Omega$	0.90	1.00	1.10	A
		ICHG set at 0.5A with $R_{ICHG} = 78.7\text{k}\Omega$	0.40	0.50	0.60	A
I_{TERM}	Termination current regulation	ICHG = 1.72A, 10% of ICHG, $R_{ICHG} = 23.2\text{k}\Omega$	138	172	206	mA
		ICHG = 1.0A, 10% of ICHG, $R_{ICHG} = 40.2\text{k}\Omega$	70	100	130	mA
		ICHG = 0.5A, $I_{TERM} = 63\text{mA}$, $R_{ICHG} = 78.7\text{k}\Omega$	33	63	93	mA
I_{PRECHG}	Precharge current	ICHG = 1.72A, 10% of ICHG, $R_{ICHG} = 23.2\text{k}\Omega$	115	172	225	mA
		ICHG = 1.0A, 10% of ICHG, $R_{ICHG} = 40.2\text{k}\Omega$	50	100	150	mA
		ICHG = 0.5A, $R_{ICHG} = 78.7\text{k}\Omega$	28	63	98	mA
$V_{BAT_SHORT_RISE}$	V_{BAT} short rising threshold	Short to precharge	2.05	2.20	2.35	V
$V_{BAT_SHORT_FALL}$	V_{BAT} short falling threshold	Precharge to short	1.85	2.00	2.15	V
I_{BAT_SHORT}	Battery short current	$V_{BAT} < V_{BAT_SHORT_FALL}$	25	35	46	mA
$V_{BAT_LOWV_RISE}$	Rising threshold	Precharge to fast charge	2.90	3.00	3.10	V
$V_{BAT_LOWV_FALL}$	Falling threshold	Fast charge to precharge	2.60	2.70	2.80	V
V_{RECHG_HYS}	Recharge hysteresis below V_{BATREG}	V_{BAT} falling	110	160	216	mV
INPUT VOLTAGE / CURRENT REGULATION						
V_{INDPM_MIN}	Minimum input voltage regulation	$V_{BAT} = 3.5\text{V}$, measured at PMID pin	3.9	4.00	4.1	V
V_{INDPM}	Input voltage regulation	$V_{BAT} = 4\text{V}$, measured at PMID pin, $V_{INDPM} = 1.085 \cdot V_{BAT} + 0.025\text{V}$	4.27	4.37	4.47	V
I_{INDPM_3A}	Input current regulation	$V_{BUS} = 5\text{V}$	3.00	3.35	3.70	A
BATTERY OVER-VOLTAGE PROTECTION						
$V_{BAT_OVP_RISE}$	Battery overvoltage rising threshold	V_{BAT} rising, as percentage of V_{BATREG} ($V_{BATREG} = 4.15\text{V}$)			104.0	%
$V_{BAT_OVP_RISE}$	Battery overvoltage rising threshold	V_{BAT} rising, as percentage of V_{BATREG}	101.9	103.5	105.0	%
$V_{BAT_OVP_FALL}$	Battery overvoltage falling threshold	V_{BAT} falling, as percentage of V_{BATREG}	100.0	101.6	103.1	%
CONVERTER PROTECTION						
$V_{BTST_REFRESH}$	Bootstrap refresh comparator threshold	$(V_{BTST} - V_{SW})$ when LSFET refresh pulse is requested, $V_{BUS} = 5\text{V}$	2.7	3	3.3	V
I_{HSFET_OCP}	HSFET cycle by cycle over current limit threshold		5.2	6.2	6.7	A
STAT INDICATION						
I_{STAT_SINK}	STAT pin sink current		6			mA
F_{BLINK2}	STAT pin blink frequency			1		Hz
F_{BLINK_DUTY}	STAT pin blink duty cycle			50		%
THERMAL REGULATION AND THERMAL SHUTDOWN						

8.5 Electrical Characteristics (continued)

$V_{VBUS_UVLOZ} < V_{VBUS} < V_{VBUS_OVP}$ and $V_{VBUS} > V_{BAT} + V_{SLEEP}$, $L=2.2\mu H$, $T_J = -40^\circ C$ to $+125^\circ C$, and $T_J = 25^\circ C$ for typical values (unless otherwise noted)

PARAMETER		TEST CONDITIONS	MIN	TYP	MAX	UNIT
T_{REG}	Junction temperature regulation accuracy		111	120	133	$^\circ C$
T_{SHUT}	Thermal Shutdown Rising threshold	Temperature increasing		150		$^\circ C$
	Thermal Shutdown Falling threshold	Temperature decreasing		125		$^\circ C$
BUCK MODE OPERATION						
F_{SW}	PWM switching frequency	SW node frequency	1.02	1.20	1.38	MHz
D_{MAX}	Maximum PWM Duty Cycle			97.0		%
REGN LDO						
V_{REGN_UVLO}	REGN UVLO	V_{VBUS} rising			3.85	V
V_{REGN}	REGN LDO output voltage	$V_{VBUS} = 5V$, $I_{REGN} = 0$ to 16mA	4.20		5.0	V
V_{REGN}	REGN LDO output voltage	$V_{VBUS} = 12V$, $I_{REGN} = 16mA$	4.50		5.40	V
ICHG SETTING						
V_{ICHG}	ICHG pin regulated voltage		993	998	1003	mV
$R_{ICHG_SHORT_FALL}$	Resistance to disable charge		1.00			k Ω
$R_{ICHG_OPEN_RISE}$	Resistance to disable charge				565	k Ω
R_{ICHG}	Programmable resistance at ICHG	$V_{BUS} = 5V$, resistance decrease	11.70		250	k Ω
R_{ICHG_HIGH}	ICHG setting resistor threshold to clamp precharge and termination current to 63mA	$R_{ICHG} > R_{ICHG_HIGH}$	60.0	65.0	70.0	k Ω
K_{ICHG}	Charge current ratio	ICHG set at 1.72A with $R_{ICHG} = 23.2k\Omega$, $V_{BAT} = 3.8V$, $V_{BUS} = 5V$, $ICHG = K_{ICHG} / R_{ICHG}$	36000	40000	44000	Ax Ω
		ICHG set at 1.0A with $R_{ICHG} = 40.2k\Omega$, $V_{BAT} = 3.8V$, $V_{BUS} = 5V$, $ICHG = K_{ICHG} / R_{ICHG}$	36000	40280	44000	Ax Ω
		ICHG set at 0.5A with $R_{ICHG} = 78.7k\Omega$, $V_{BAT} = 3.8V$, $V_{BUS} = 5V$, $ICHG = K_{ICHG} / R_{ICHG}$	32000	40700	48000	Ax Ω
JEITA THERMISTOR COMPARATORS						
COLD/HOT THERMISTOR COMPARATOR						
$V_{T1}\%$	TCOLD ($0^\circ C$) threshold, charge suspended if thermistor temperature is below T1	V_{TS} rising, as percentage to V_{REGN}	72.68	73.5	74.35	%
$V_{T1}\%$	V_{TS} falling	As Percentage to V_{REGN}	70.68	71.5	72.33	%
$V_{T3}\%$	THOT ($45^\circ C$) threshold, charge suspended if thermistor temperature is above T3	V_{TS} falling, as percentage to V_{REGN}	46.35	47.25	48.15	%
$V_{T3}\%$	V_{TS} Rising	As percentage to V_{REGN}	47.35	48.25	49.15	%
LOGIC I/O PIN CHARACTERISTICS (POL, EN)						
V_{ILO}	Input low threshold	Falling			0.40	V
V_{IH}	Input high threshold	Rising	1.3			V
I_{BIAS}	High-level leakage current at EN pin	EN pin is pulled up to 1.8 V		1.0		μA

8.6 Timing Requirements

PARAMETER		TEST CONDITIONS	MIN	NOM	MAX	UNIT
VBUS/BAT POWER UP						
$t_{CHG_ON_EN}$	Delay from enable at /EN pin to charger power on	/EN pin voltage rising		245		ms

8.6 Timing Requirements (continued)

PARAMETER		TEST CONDITIONS	MIN	NOM	MAX	UNIT
t _{CHG_ON_VBUS}	Delay from VBUS to charge start	/EN pin is grounded, battery present		275		ms
BATTERY CHARGER						
t _{SAFETY_FAST}	Charge safety timer	Fast charge safety timer 20 hours	15.0	20.0	24.0	hr
t _{SAFETY_PRE}	Charge safety timer	Precharge safety timer	1.5	2.0	2.5	hr

8.7 Typical Characteristics

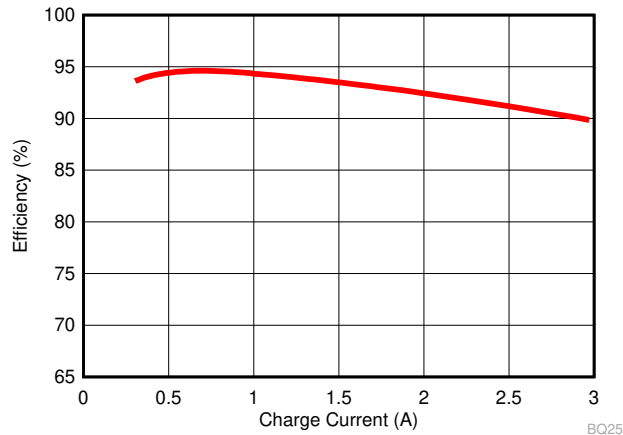

$f_{SW} = 1.2 \text{ MHz}$ Inductance = 1.0 μH
 $V_{BUS} = 5.0 \text{ V}$, $V_{BAT} = 3.8 \text{ V}$ Inductor DCR = 10 $\text{m}\Omega$

8-1. 1-Cell Battery Charge Efficiency vs. Charge Current

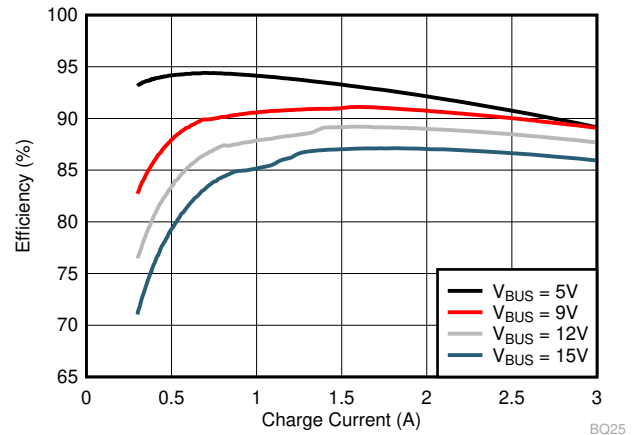

$f_{SW} = 1.2 \text{ MHz}$ Inductance = 2.2 μH
 $V_{BAT} = 3.8 \text{ V}$ Inductor DCR = 20 $\text{m}\Omega$

8-2. 1-Cell Battery Charge Efficiency vs. Charge Current

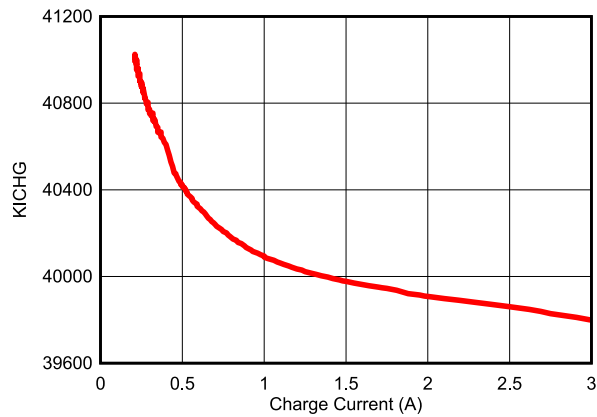

8-3. KICHG vs. Charge Current

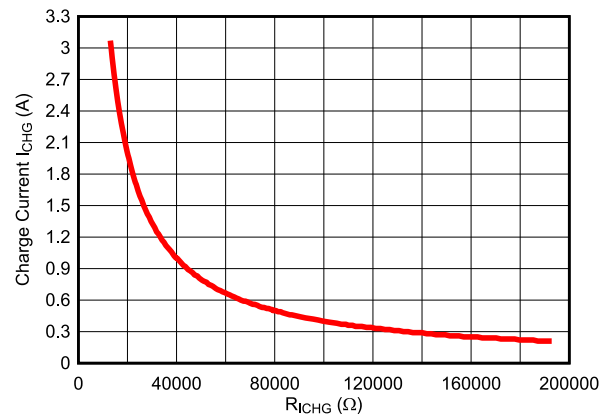

8-4. Charge Current vs. Charge Current Setting Resistance R_{ICHG}

9 Detailed Description

9.1 Overview

The BQ25300 is a highly integrated standalone switch-mode battery charger for single cell Li-Ion and Li-polymer batteries with charge voltage and charge current programmable by an external resistor. It includes an input reverse-blocking FET (RBFET, Q1), high-side switching FET (HSFET, Q2), low-side switching FET (LSFET, Q3), and bootstrap diode for the high-side gate drive as well as current sensing circuitry.

9.2 Functional Block Diagram

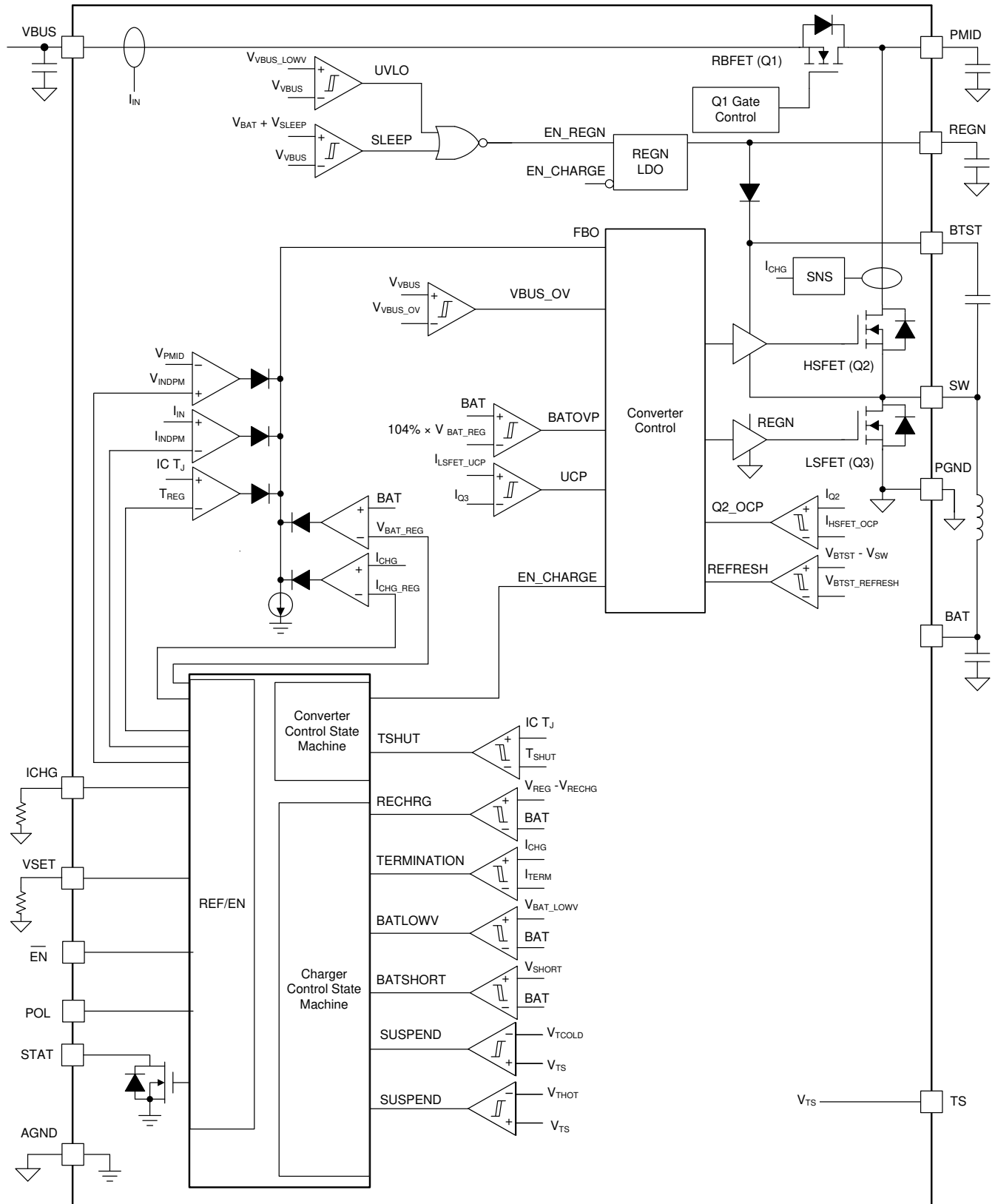

9.3 Feature Description

9.3.1 Device Power Up

The $\overline{\text{EN}}$ pin enable or disable the device. When the device is disabled, the device draws minimum current from VBUS pin. The device can be powered up from either VBUS or by enabling the device from $\overline{\text{EN}}$ pin.

9.3.1.1 Power-On-Reset (POR)

The $\overline{\text{EN}}$ pin can enable or disable the device. When the device is disabled, the device is in disable mode and it draws minimum current at VBUS. When the device is enabled, if VBUS rises above $V_{\text{VBUS_UVLOZ}}$, the device powers part of internal bias and comparators and starts Power on Reset (POR).

9.3.1.2 REGN Regulator Power Up

The internal bias circuits are powered from the input source. The REGN supplies internal bias circuits as well as the HSFET and LSFET gate drive. The REGN also provides voltage rail to STAT LED indication. The REGN is enabled when all the below conditions are valid:

- Chip is enabled by $\overline{\text{EN}}$ pin
- V_{VBUS} above $V_{\text{VBUS_UVLOZ}}$
- V_{VBUS} above $V_{\text{BAT}} + V_{\text{SLEEPZ}}$
- After sleep comparator deglitch time, VSET detection time, and REGN delay time

REGN remains on at fault conditions. REGN is powered by VBUS only and REGN is off when VBUS power is removed.

9.3.1.3 Charger Power Up

Following REGN power-up, if there is no fault conditions, the charger powers up with soft start. If there is any fault, the charger will remain off until fault is clear. Any of the fault conditions below gates charger power-up:

- $V_{\text{VBUS}} > V_{\text{VBUS_OVP}}$
- Thermistor cold/hot fault on TS pin
- $V_{\text{BAT}} > V_{\text{BAT_OVP}}$
- Safety timer fault
- ICHG pin is open or short to GND
- Die temperature is above TSHUT

9.3.1.4 Charger Enable and Disable by $\overline{\text{EN}}$ Pin

With POL pin floating, the charger can be enabled with $\overline{\text{EN}}$ pin pulled low (or floating) or disabled by $\overline{\text{EN}}$ pin pulled high. The charger is in [disable mode](#) when disabled.

9.3.1.5 Device Unplugged from Input Source

When V_{BUS} is removed from an adaptor, the device stays in HiZ mode and the leakage current from the battery to BAT pin and SW pin is less than $I_{\text{Q_BAT_HIZ}}$.

9.3.2 Battery Charging Management

The BQ25300 charges 1-cell Li-Ion battery with up to 3.0-A charge current for high capacity battery from 4.1-V to 17-V input voltage. A new charge cycle starts when the charger power-up conditions are met. The charge voltage is set by external resistor connected at VSET pin and charge current are set by external resistors at ICHG pin. The charger terminates the charging cycle when the charging current is below termination threshold I_{TERM} and charge voltage is above recharge threshold ($V_{\text{BATREG}} - V_{\text{RECHG_HYS}}$), and device is not in IINDPM or thermal regulation. When a fully charged battery's voltage is discharged below recharge threshold, the device automatically starts a new charging cycle with safety timer reset. To initiate a recharge cycle, the conditions of charger power-up must be met. The STAT pin output indicates the charging status of charging (LOW), charging complete or charge disabled (HIGH) or charging faults (BLINKING).

9.3.2.1 Battery Charging Profile

The device charges the battery in four phases: battery short, preconditioning, constant current, constant voltage. The device charges battery based on charge voltage set by VSET pin and charge current set by ICHG pin as well as actual battery voltage. The battery charging profile is shown in [Figure 9-1](#). The battery short current is provided by internal linear regulator.

表 9-1. Charging Current Setting

MODE	BATTERY VOLTAGE V_{BAT}	CHARGE CURRENT	TYPICAL VALUE
Battery Short	$V_{BAT} < V_{BAT_SHORT}$	I_{BAT_SHORT}	35 mA
Precharge	$V_{BAT_SHORT} < V_{BAT} < V_{BAT_LOWV}$	I_{PRECHG}	10% of I_{CHG} ($I_{PRE} > 63mA$)
Fast Charge	$V_{BAT_LOWV} < V_{BAT}$	I_{CHG}	Set by ICHG resistor

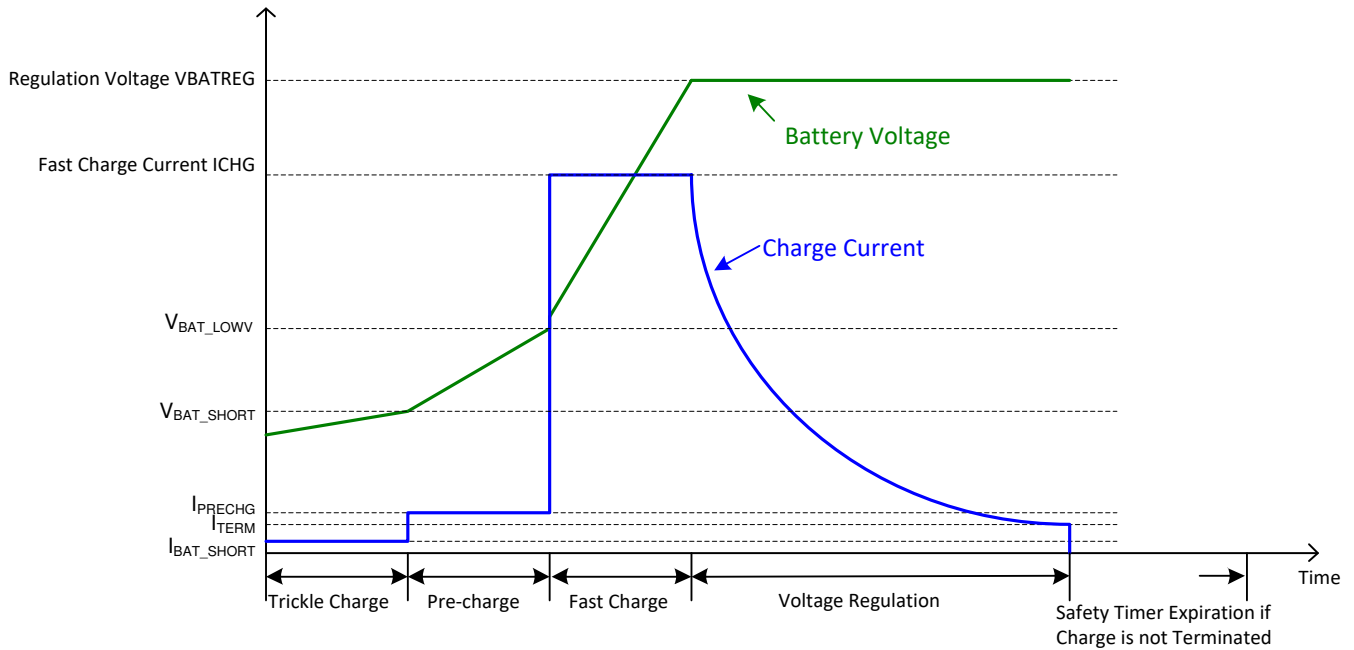

Figure 9-1. Battery Charging Profile

9.3.2.2 Precharge

The device charges the battery at 10% of set fast charge current in precharge mode. When $R_{ICHG} > R_{ICHG_HIGH}$, the precharge current is clamped at 63mA.

9.3.2.3 Charging Termination

The device terminates a charge cycle when the battery voltage is above recharge threshold and the charge current is below termination current. After a charging cycle is completed, the converter stops switching, charge is terminated and the system load is powered from battery. Termination is temporarily disabled when the charger device is in input current regulation or thermal regulation mode and the charging safety timer is counted at half the clock rate. The charge termination current is 10% of set fast charge current if $R_{ICHG} < R_{ICHG_HIGH}$. The termination current is clamped at 63mA if $R_{ICHG} > R_{ICHG_HIGH}$.

9.3.2.4 Battery Recharge

A charge cycle is completed when battery is fully charged with charge terminated. If the battery voltage decreases below the recharge threshold ($V_{BATREG} - V_{RECHG_HYS}$), the charger is enabled with safety timer reset and enabled.

9.3.2.5 Charging Safety Timer

The device has built-in safety timer to prevent extended charging cycle due to abnormal battery conditions. The safety timer is 20 hours when the battery voltage is above V_{BAT_LOWV} threshold and 2 hours below V_{BAT_LOWV} threshold. When the safety timer expires, charge is suspended until the safety timer is reset. Safety timer is reset and charge starts under one of the following conditions:

- Battery voltage falls below recharge threshold
- VBUS voltage is recycled
- \overline{EN} pin is toggled
- Battery voltage transits across V_{BAT_SHORT} threshold
- Battery voltage transits across V_{BAT_LOWV} threshold

If the safety timer expires and the battery voltage is above recharge threshold, the charger is suspended and the STAT pin is open. If the safety timer expires and the battery voltage is below the recharge threshold, the charger is suspended and the STAT pin blinks to indicate a fault. The safety timer fault is cleared with safety timer reset.

During input current regulation, thermal regulation, the safety timer counts at half the original clock frequency and the safety timer is doubled. During TS fault, V_{BUS_OVP} , V_{BAT_OVP} , ICHG pin open and short, and IC thermal shutdown faults, the safety timer is suspended. Once the fault(s) is clear, the safety timer resumes to count.

9.3.2.6 Thermistor Temperature Monitoring

The charger device provides a single thermistor input TS pin for battery temperature monitor. RT1 and RT2 programs the cold temperature T1 and hot temperature T3. In the equations, $R_{NTC,T1}$ is NTC thermistor resistance value at temperature T1 and $R_{NTC,T3}$ is NTC thermistor resistance values at temperature T3. Select 0°C to 45°C for battery charge temperature range, then NTC thermistor 103AT-2 resistance $R_{NTC,T1} = 27.28$ k Ω (at 0°C) and $R_{NTC,T3} = 4.91$ k Ω (at 45°C), from 式 1 and 式 2, RT1 and RT2 are derived as:

- RT1 = 4.53 k Ω
- RT2 = 22.6 k Ω



图 9-2. Battery Temperature Sensing Circuit

$$RT2 = \frac{R_{NTC,T1} \times R_{NTC,T3} \times \left(\frac{1}{V_{T3\%}} - \frac{1}{V_{T1\%}} \right)}{R_{NTC,T1} \times \left(\frac{1}{V_{T1\%}} - 1 \right) - R_{NTC,T3} \times \left(\frac{1}{V_{T3\%}} - 1 \right)} \quad (1)$$

$$RT1 = \frac{\frac{1}{V_{T1\%}} - 1}{\frac{1}{R_{T2}} + \frac{1}{R_{NTC,T1}}} \quad (2)$$

9.3.3 Charging Status Indicator (STAT)

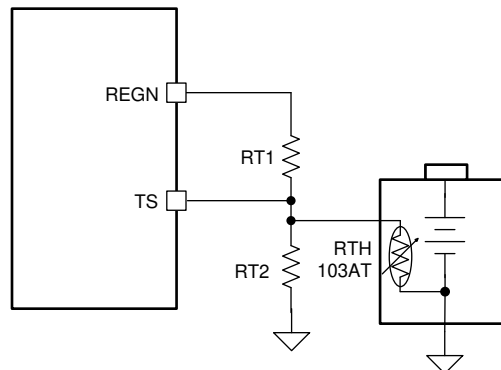
The device indicates charging state on the open drain STAT pin. The STAT pin can drive a LED that is pulled up to REGN rail through a current limit resistor.

表 9-2. STAT Pin State

CHARGING STATE	STAT INDICATOR
Charging in progress (including recharge)	LOW
Charging complete	HIGH
HiZ mode, sleep mode, charge disable	HIGH
Safety timer expiration with battery voltage above recharge threshold	HIGH
Charge faults: 1. VBUS input over voltage 2. TS cold/hot faults 3. Battery over voltage 4. IC thermal shutdown 5. Safety timer expiration with battery voltage below recharge threshold 6. ICHG pin open or short	BLINKING at 1 Hz with 50% duty cycle

9.3.4 Protections

9.3.4.1 Voltage and Current Monitoring

The device closely monitors the input voltage and input current for safe operation.

9.3.4.1.1 Input Over-Voltage Protection

This device integrates the functionality of an input over-voltage protection (OVP). The input OVP threshold is $V_{VBUS_OVP_RISE}$. During an input over-voltage event, the converter stops switching and safety timer stops counting as well. The converter resumes switching and the safety timer resumes counting once the VBUS voltage drops back below $(V_{VBUS_OVP_RISE} - V_{VBUS_OVP_HYS})$. The REGN LDO remains on during an input over-voltage event. The STAT pin blinks during an input OVP event.

9.3.4.1.2 Input Voltage Dynamic Power Management (VINDPM)

When the input current of the device exceeds the current capability of the power supply, the charger device regulates PMID voltage by reducing charge current to avoid crashing the input power supply. VINDPM dynamically tracks the battery voltage. The actual VINDPM is the higher of V_{INDPM_MIN} and $(1.085 \cdot V_{BAT} + 25mV)$.

9.3.4.1.3 Input Current Limit

The device has built-in input current limit. When the input current is over the threshold I_{INDPM} , the converter duty cycle is reduced to reduce input current.

9.3.4.1.4 Cycle-by-Cycle Current Limit

High-side (HS) FET current is cycle-by-cycle limited. Once the HSFET peak current hits the limit I_{HSFET_OCP} , the HSFET shuts down until the current is reduced below a threshold.

9.3.4.2 Thermal Regulation and Thermal Shutdown

The device monitors the junction temperature T_J to avoid overheating the chip and limit the device surface temperature. When the internal junction temperature exceeds thermal regulation limit T_{REG} , the device lowers down the charge current. During thermal regulation, the average charging current is usually below the programmed battery charging current. Therefore, termination is disabled and the safety timer runs at half the clock rate.

Additionally, the device has thermal shutdown built in to turn off the charger when device junction temperature exceeds T_{SHUT} rising threshold. The charger is reenabled when the junction temperature is below T_{SHUT} falling

threshold. During thermal shutdown, the safety timer stops counting and it resumes when the temperature drops below the threshold.

9.3.4.3 Battery Protection

9.3.4.3.1 Battery Over-Voltage Protection (V_{BAT_OVP})

The battery voltage is clamped at above the battery regulation voltage. When the battery voltage is over $V_{BAT_OVP_RISE}$, the converter stops switching until the battery voltage is below the falling threshold. During a battery over-voltage event, the safety timer stops counting and STAT pin reports the fault and it resumes once the battery voltage falls below the falling threshold. A 7-mA pull-down current is on the BAT pin once BAT_OVP is triggered. BAT_OVP may be triggered in charging mode, termination mode, and fault mode.

9.3.4.3.2 Battery Short Circuit Protection

When the battery voltage falls below the V_{BAT_SHORT} threshold, the charge current is reduced to I_{BAT_SHORT} .

9.3.4.4 ICHG Pin Open and Short Protection

To protect against ICHG pin is short or open, the charger immediately shuts off once ICHG pin is open or short to GND and STAT pin blinks to report the fault. At powerup, if ICHG pin is detected open or short to GND, the charge will not power up until the fault is clear.

9.4 Device Functional Modes

9.4.1 Disable Mode, HiZ Mode, Sleep Mode, Charge Mode, Termination Mode, and Fault Mode

The device operates in different modes depending on VBUS voltage, battery voltage, and \overline{EN} pin, POL pin, and ICHG pin connection. The functional modes are listed in the following table.

表 9-3. Device Functional Modes

MODE	CONDITIONS	REGN LDO	CHARGE ENABLED	STAT PIN
Disable Mode	Device is disabled, POL floating or pulled high, and \overline{EN} pulled high	OFF	NO	OPEN
	Device is disabled, POL pulled low, \overline{EN} pulled low or floating	OFF	NO	OPEN
HiZ Mode	Device is enabled and $V_{VBUS} < V_{VBUS_UVLOZ}$	OFF	NO	OPEN
Sleep Mode	Device is enabled and $V_{VBUS} > V_{VBUS_UVLOZ}$ and $V_{VBUS} < V_{BAT} + V_{SLEEPZ}$	OFF	NO	OPEN
Charge Mode	Device is enabled, $V_{VBUS} > V_{VBUS_LOWV}$ and $V_{VBUS} > V_{BAT} + V_{SLEEPZ}$, no faults, charge is not terminated	ON	YES	SHORT to GND
Charge Termination Mode	$V_{VBUS} > V_{VBUS_LOWV}$ and $V_{VBUS} > V_{BAT} + V_{SLEEPZ}$ and device is enabled, no faults, charge is terminated	ON	NO	OPEN
Fault Mode	V_{BUS_OVP} , TS cold/hot, V_{BAT_OVP} , IC thermal shutdown, safety timer fault, ICHG pin open or short	ON	NO	BLINKING

10 Application and Implementation

注

以下のアプリケーション情報は、TI の製品仕様に含まれるものではなく、TI ではその正確性または完全性を保証いたしません。個々の目的に対する製品の適合性については、お客様の責任で判断していただくこととなります。また、お客様は自身の設計実装を検証しテストすることで、システムの機能を確認する必要があります。

10.1 Application Information

A typical application consists of a single cell battery charger for Li-Ion, Li-polymer and LiFePO₄ batteries used in a wide range of portable devices and accessories. It integrates an input reverse-block FET (RBFET, Q1), high-side switching FET (HSFET, Q2), and low-side switching FET (LSFET, Q3). The Buck converter output is connected to the battery directly to charge the battery and power system loads. The device also integrates a bootstrap diode for high-side gate drive.

10.2 Typical Applications

The typical applications in this section include a standalone charger without power path, and a standalone charger with external power path.

10.2.1 Typical Application

The typical application in this section includes a standalone charger without power path.



图 10-1. Typical Application Diagram

10.2.1.1 Design Requirements

表 10-1. Design Requirements

PARAMETER	VALUE
Input Voltage	4.1V to 17V
Input Current	3.0A
Fast Charge Current	3.0A
Battery Regulation Voltage	3.6/4.05V/4.15V/4.2V

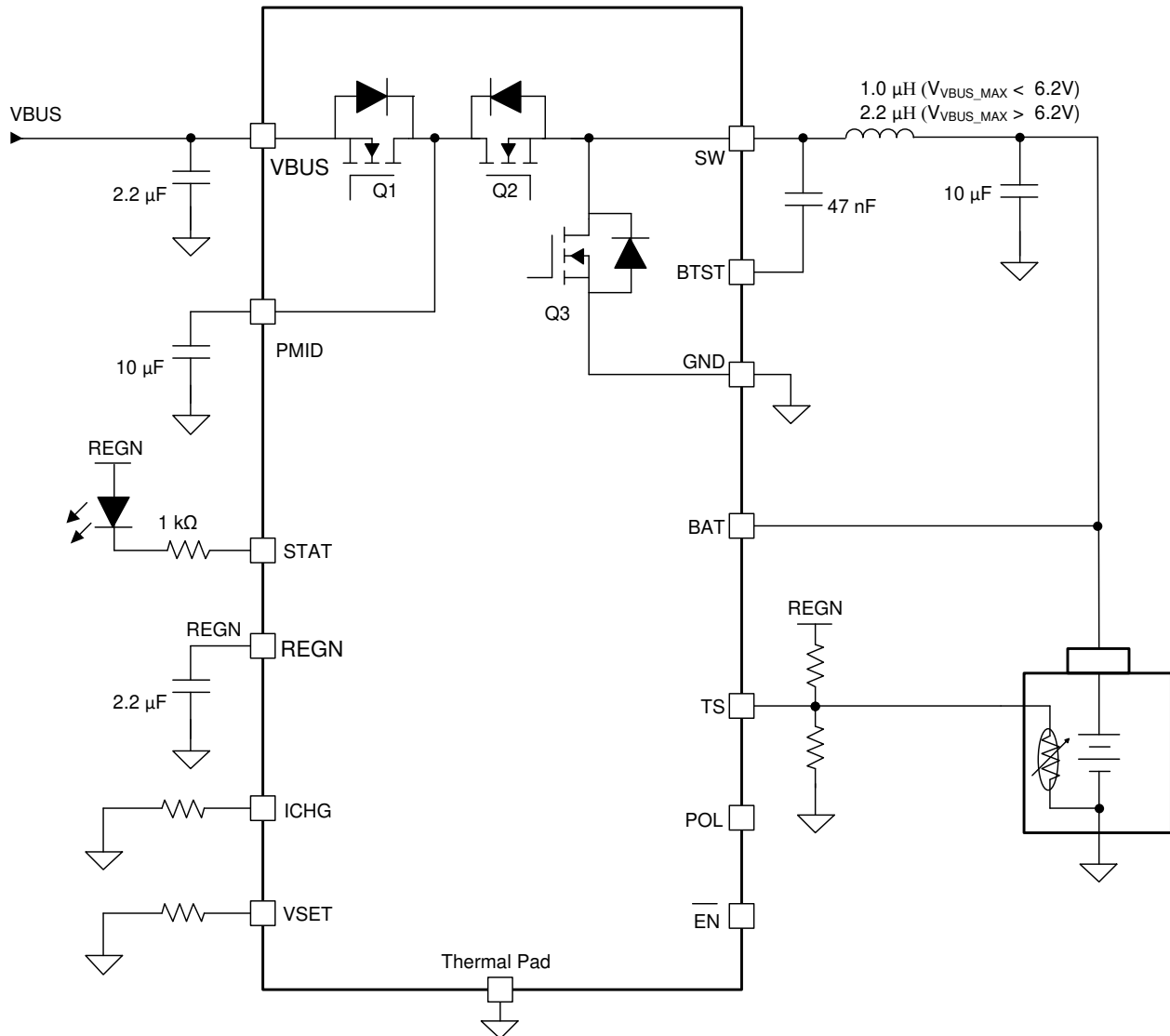
10.2.1.2 Detailed Design Procedure

10.2.1.2.1 Charge Voltage Settings

Battery charge voltage is set by a resistor connected at the VSET pin. When the REGN LDO startup conditions are met, and before the REGN LDO powers up, the internal VSET detection circuit is enabled to detect VSET pin

resistance and set battery charge voltage accordingly. The VSET detection circuit is disabled after detection is complete and changing resistance values on the fly does not change the battery charge voltage. VSET detection is reenabled once the REGN LDO is recycled.

10.2.1.2.2 Charge Current Setting

The charger current is set by the resistor value at the ICHG pin according to the equation below:

$$I_{CHG} (A) = K_{ICHG} (A \cdot \Omega) / R_{ICHG} (\Omega)$$

K_{ICHG} is a coefficient that is listed in Electrical Characteristics table and R_{ICHG} is the resistor value from ICHG pin to GND. K_{ICHG} is typically 40,000 (A·Ω) and it is slightly shifted up at lower charge current setting. The K_{ICHG} vs. ICHG typical characteristic curve is shown in [Figure 8-3](#).

10.2.1.2.3 Inductor Selection

The 1.2-MHz switching frequency allows the use of small inductor and capacitor values. Inductance value is selected based on maximum input voltage V_{VBUS_MAX} in applications. 1-μH inductor is recommended if $V_{VBUS_MAX} < 6.2V$ and 2.2-μH inductor is recommended if $V_{VBUS_MAX} > 6.2V$. An inductor saturation current I_{SAT} should be higher than the charging current I_{CHG} plus half the ripple current I_{RIPPLE} :

$$I_{SAT} \geq I_{CHG} + (1/2) I_{RIPPLE} \quad (3)$$

The inductor ripple current I_{RIPPLE} depends on the input voltage (V_{VBUS}), the duty cycle ($D = V_{BAT}/V_{VBUS}$), the switching frequency (f_s) and the inductance (L).

$$I_{RIPPLE} = \frac{V_{IN} \times D \times (1 - D)}{f_s \times L} \quad (4)$$

The maximum inductor ripple current occurs when the duty cycle (D) is 0.5 or approximately 0.5.

10.2.1.2.4 Input Capacitor

Design input capacitance to provide enough ripple current rating to absorb the input switching ripple current. Worst case RMS ripple current is half of the charging current when the duty cycle is 0.5. If the converter does not operate at 50% duty cycle, then the worst case capacitor RMS current I_{CIN} occurs where the duty cycle is closest to 50% and can be estimated using [Equation 5](#).

$$I_{CIN} = I_{CHG} \times \sqrt{D \times (1 - D)} \quad (5)$$

A low ESR ceramic capacitor such as X7R or X5R is preferred for the input decoupling capacitor and should be placed as close as possible to the drain of the high-side MOSFET and source of the low-side MOSFET. The voltage rating of the capacitor must be higher than the normal input voltage level. A rating of 25-V or higher capacitor is preferred for 15-V input voltage.

10.2.1.2.5 Output Capacitor

Ensure that the output capacitance has enough ripple current rating to absorb the output switching ripple current. The equation below shows the output capacitor RMS current I_{COUT} calculation.

$$I_{COUT} = \frac{I_{RIPPLE}}{2 \times \sqrt{3}} \approx 0.29 \times I_{RIPPLE} \quad (6)$$

The output capacitor voltage ripple can be calculated as follows:

$$\Delta V_O = \frac{V_{OUT}}{8LCf_s^2} \left(1 - \frac{V_{OUT}}{V_{IN}} \right) \quad (7)$$

At certain input and output voltage and switching frequency, the voltage ripple can be reduced by increasing the output filter LC.

10.2.1.3 Application Curves

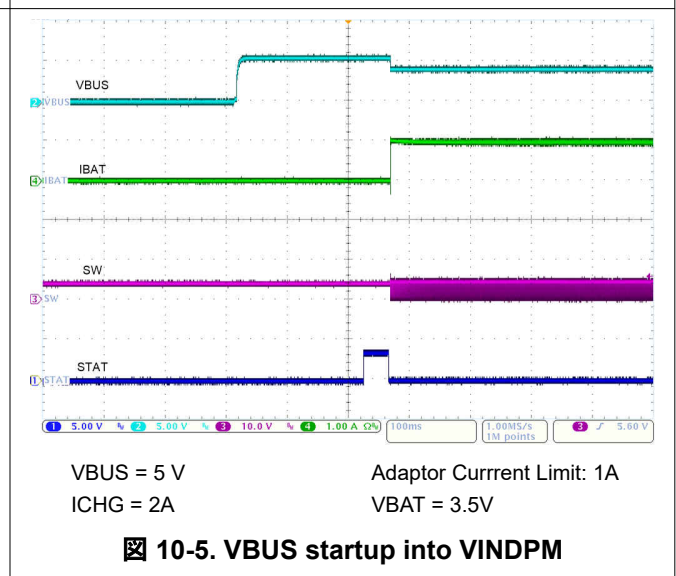
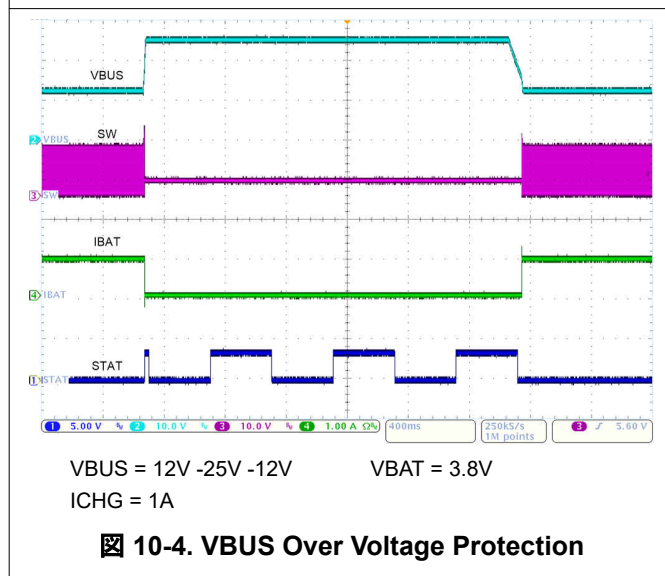
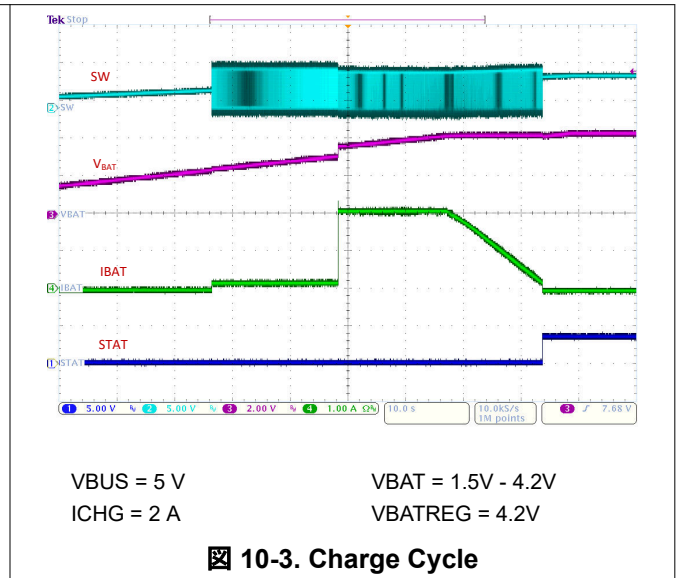
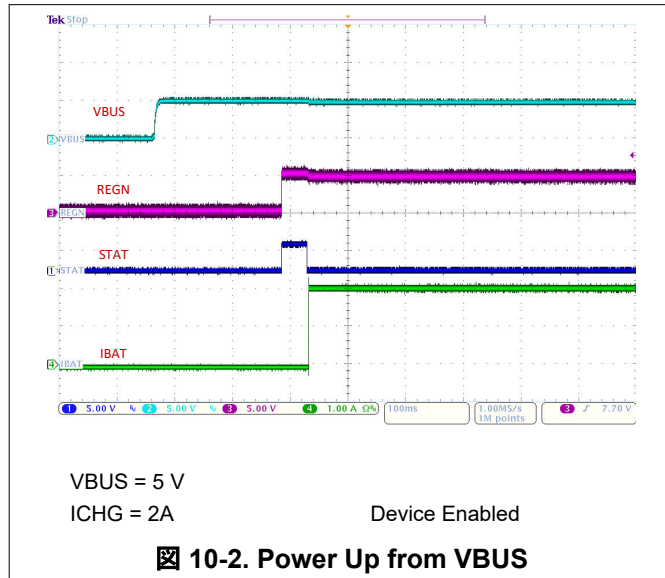

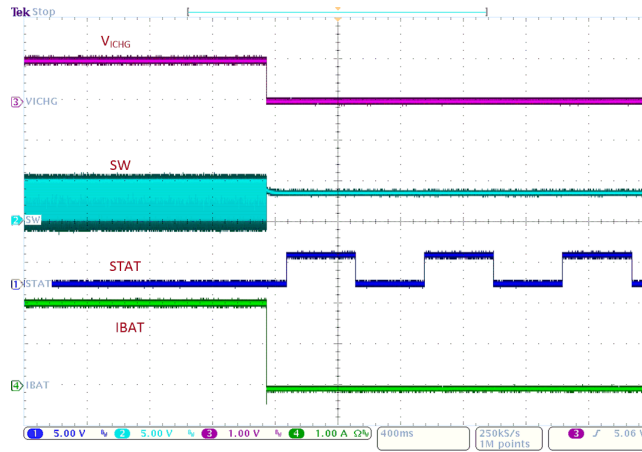

VBUS = 5 V

From ICHG = 2A to ICHG pin short

10-6. ICHG Pin Short Circuit Protection

10.2.2 Typical Application with External Power Path

In the case where a system needs to be immediately powered up from VBUS when the battery is overdischarged or dead, the application circuit shown in [Figure 10-7](#) can be used to provide a power path from VBUS/PMID to VSYS. PFET Q4 is an external PFET that turns on to supply VSYS from the battery when VBUS is removed; PFET Q4 turns off when VBUS is present and VSYS is supplied from VBUS/PMID.

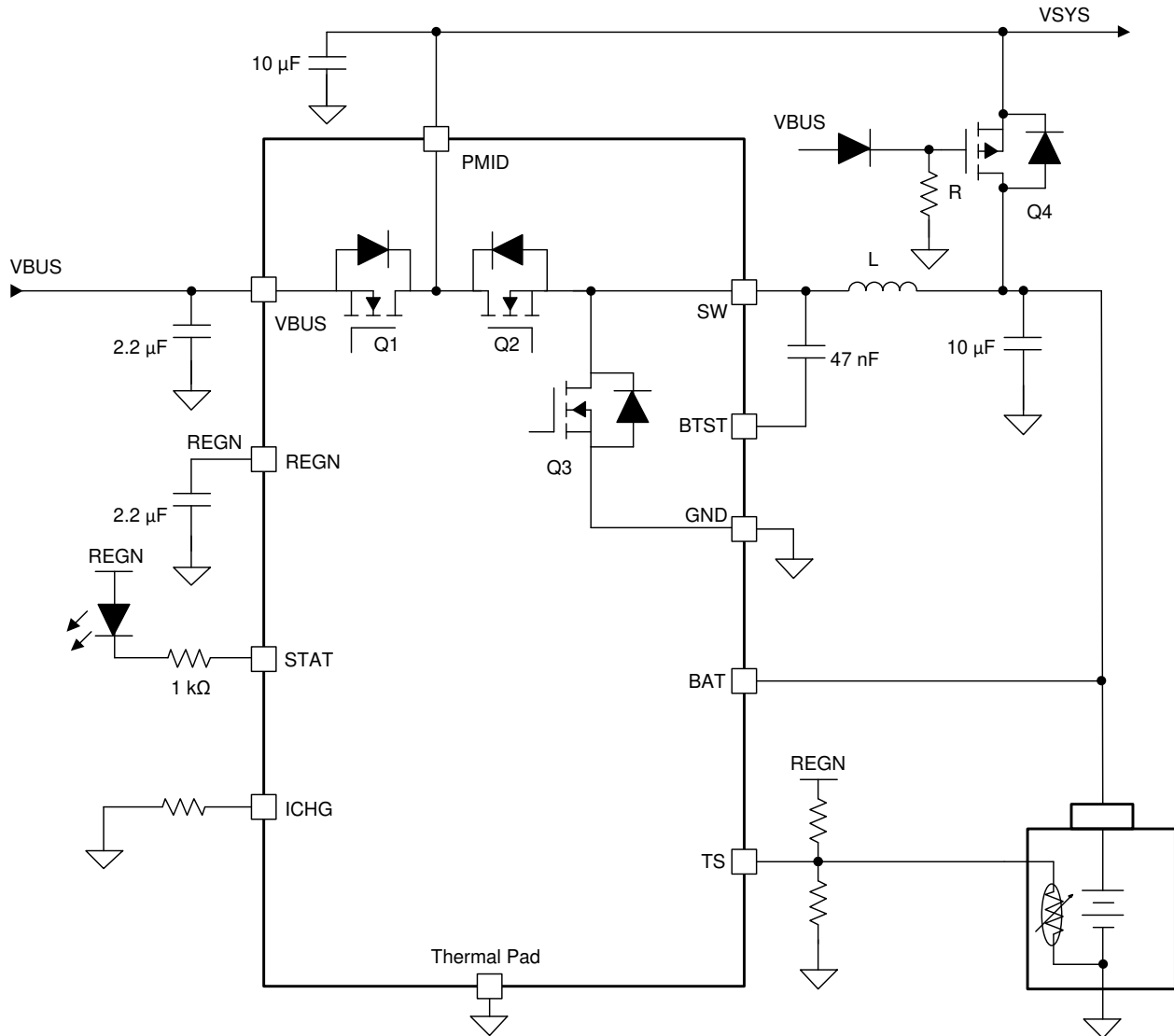

Figure 10-7. Typical Application Diagram with Power Path

10.2.2.1 Design Requirements

For design requirements, see [Section 10.2.1.1](#).

10.2.2.2 Detailed Design Procedure

For detailed design procedure, see [Section 10.2.1.2](#).

10.2.2.3 Application Curves

For application curves, see [Section 10.2.1.3](#).

11 Power Supply Recommendations

In order to provide an output voltage on the BAT pin, the device requires a power supply between 4.1 V and 17 V Li-Ion battery with positive terminal connected to BAT. The source current rating needs to be at least 3 A in order for the buck converter to provide maximum output power to BAT or the system connected to BAT pin.

12 Layout

12.1 Layout Guidelines

The switching node rise and fall times should be minimized for minimum switching loss. Proper layout of the components to minimize high frequency current path loop (see [Figure 12-1](#)) is important to prevent electrical and magnetic field radiation and high frequency resonant problems. Follow this specific order carefully to achieve the proper layout.

- Place input capacitor as close as possible to PMID pin and use shortest thick copper trace to connect input capacitor to PMID pin and GND plane.
- It is critical that the exposed thermal pad on the backside of the device be soldered to the PCB ground. Ensure that there are sufficient thermal vias directly under the IC, connecting to the ground plane on the other layers. Connect the GND pins to thermal pad on the top layer.
- Put output capacitor near to the inductor output terminal and the charger device. Ground connections need to be tied to the IC ground with a short copper trace or GND plane
- Place inductor input terminal to SW pin as close as possible and limit SW node copper area to lower electrical and magnetic field radiation. Do not use multiple layers in parallel for this connection. Minimize parasitic capacitance from this area to any other trace or plane.
- Route analog ground separately from power ground if possible. Connect analog ground and power ground together using thermal pad as the single ground connection point under the charger device. It is acceptable to connect all grounds to a single ground plane if multiple ground planes are not available.
- Decoupling capacitors should be placed next to the device pins and make trace connection as short as possible.
- For high input voltage and high charge current applications, sufficient copper area on GND should be budgeted to dissipate heat from power losses.
- Ensure that the number and sizes of vias allow enough copper for a given current path

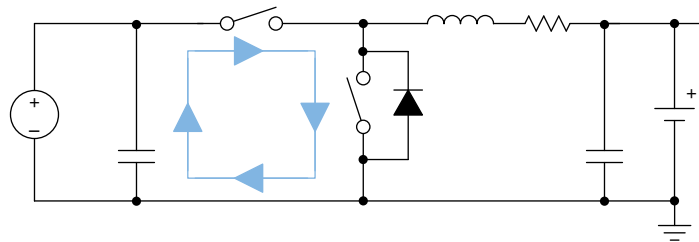
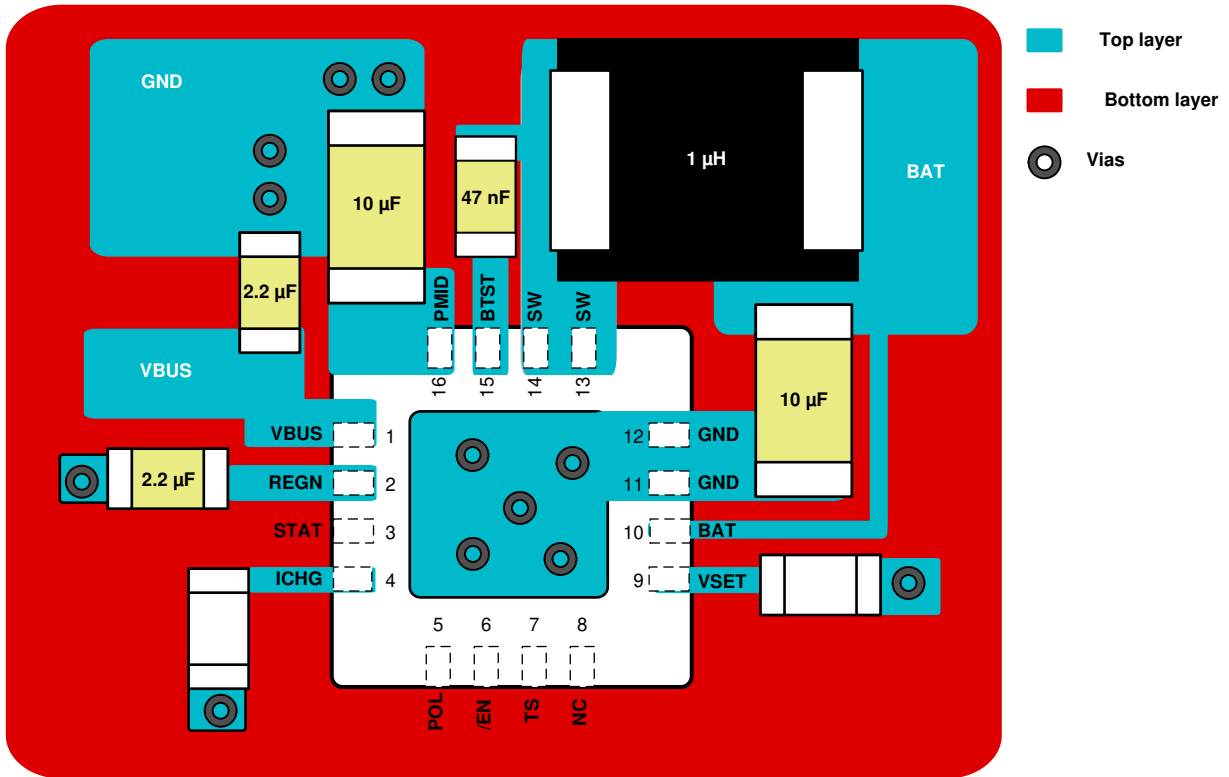

Figure 12-1. High Frequency Current Path

12.2 Layout Example

The device pinout and component count are optimized for a 2 layer PCB design. The 2-layer PCB layout example is shown in [Figure 12-2](#).



 12-2. Layout Example

13 Device and Documentation Support

13.1 Device Support

13.1.1 サード・パーティ製品に関する免責事項

サード・パーティ製品またはサービスに関するテキサス・インスツルメンツの出版物は、単独またはテキサス・インスツルメンツの製品、サービスと一緒に提供される場合に関係なく、サード・パーティ製品またはサービスの適合性に関する是認、サード・パーティ製品またはサービスの是認の表明を意味するものではありません。

13.2 ドキュメントの更新通知を受け取る方法

ドキュメントの更新についての通知を受け取るには、ti.com のデバイス製品フォルダを開いてください。「更新の通知を受け取る」をクリックして登録すると、変更されたすべての製品情報に関するダイジェストを毎週受け取れます。変更の詳細については、修正されたドキュメントに含まれている改訂履歴をご覧ください。

13.3 サポート・リソース

[TI E2E™ サポート・フォーラム](#)は、エンジニアが検証済みの回答と設計に関するヒントをエキスパートから迅速かつ直接得ることができる場所です。既存の回答を検索したり、独自の質問をしたりすることで、設計に必要な支援を迅速に得ることができます。

リンクされているコンテンツは、該当する貢献者により、現状のまま提供されるものです。これらは TI の仕様を構成するものではなく、必ずしも TI の見解を反映したものではありません。TI の[使用条件](#)を参照してください。

13.4 Trademarks

TI E2E™ is a trademark of Texas Instruments.

すべての商標は、それぞれの所有者に帰属します。

13.5 静電気放電に関する注意事項



この IC は、ESD によって破損する可能性があります。テキサス・インスツルメンツは、IC を取り扱う際には常に適切な注意を払うことを推奨します。正しい ESD 対策をとらないと、デバイスを破損するおそれがあります。

ESD による破損は、わずかな性能低下からデバイスの完全な故障まで多岐にわたります。精密な IC の場合、パラメータがわずかに変化するだけで公表されている仕様から外れる可能性があるため、破損が発生しやすくなっています。

13.6 用語集

[TI 用語集](#) この用語集には、用語や略語の一覧および定義が記載されています。

14 Mechanical, Packaging, and Orderable Information

The following pages include mechanical, packaging, and orderable information. This information is the most current data available for the designated devices. This data is subject to change without notice and revision of this document. For browser-based versions of this data sheet, refer to the left-hand navigation.

PACKAGING INFORMATION

Orderable part number	Status (1)	Material type (2)	Package Pins	Package qty Carrier	RoHS (3)	Lead finish/ Ball material (4)	MSL rating/ Peak reflow (5)	Op temp (°C)	Part marking (6)
BQ25300RTER	Active	Production	WQFN (RTE) 16	3000 LARGE T&R	Yes	NIPDAU	Level-1-260C-UNLIM	-40 to 85	B25300
BQ25300RTER.A	Active	Production	WQFN (RTE) 16	3000 LARGE T&R	Yes	NIPDAU	Level-1-260C-UNLIM	-40 to 85	B25300
BQ25300RTER.B	Active	Production	WQFN (RTE) 16	3000 LARGE T&R	Yes	NIPDAU	Level-1-260C-UNLIM	-40 to 85	B25300

(1) **Status:** For more details on status, see our [product life cycle](#).

(2) **Material type:** When designated, preproduction parts are prototypes/experimental devices, and are not yet approved or released for full production. Testing and final process, including without limitation quality assurance, reliability performance testing, and/or process qualification, may not yet be complete, and this item is subject to further changes or possible discontinuation. If available for ordering, purchases will be subject to an additional waiver at checkout, and are intended for early internal evaluation purposes only. These items are sold without warranties of any kind.

(3) **RoHS values:** Yes, No, RoHS Exempt. See the [TI RoHS Statement](#) for additional information and value definition.

(4) **Lead finish/Ball material:** Parts may have multiple material finish options. Finish options are separated by a vertical ruled line. Lead finish/Ball material values may wrap to two lines if the finish value exceeds the maximum column width.

(5) **MSL rating/Peak reflow:** The moisture sensitivity level ratings and peak solder (reflow) temperatures. In the event that a part has multiple moisture sensitivity ratings, only the lowest level per JEDEC standards is shown. Refer to the shipping label for the actual reflow temperature that will be used to mount the part to the printed circuit board.

(6) **Part marking:** There may be an additional marking, which relates to the logo, the lot trace code information, or the environmental category of the part.

Multiple part markings will be inside parentheses. Only one part marking contained in parentheses and separated by a "-" will appear on a part. If a line is indented then it is a continuation of the previous line and the two combined represent the entire part marking for that device.

Important Information and Disclaimer: The information provided on this page represents TI's knowledge and belief as of the date that it is provided. TI bases its knowledge and belief on information provided by third parties, and makes no representation or warranty as to the accuracy of such information. Efforts are underway to better integrate information from third parties. TI has taken and continues to take reasonable steps to provide representative and accurate information but may not have conducted destructive testing or chemical analysis on incoming materials and chemicals. TI and TI suppliers consider certain information to be proprietary, and thus CAS numbers and other limited information may not be available for release.

In no event shall TI's liability arising out of such information exceed the total purchase price of the TI part(s) at issue in this document sold by TI to Customer on an annual basis.

TAPE AND REEL INFORMATION

QUADRANT ASSIGNMENTS FOR PIN 1 ORIENTATION IN TAPE

*All dimensions are nominal

Device	Package Type	Package Drawing	Pins	SPQ	Reel Diameter (mm)	Reel Width W1 (mm)	A0 (mm)	B0 (mm)	K0 (mm)	P1 (mm)	W (mm)	Pin1 Quadrant
BQ25300RTER	WQFN	RTE	16	3000	330.0	12.4	3.3	3.3	1.1	8.0	12.0	Q2
BQ25300RTER	WQFN	RTE	16	3000	330.0	12.4	3.3	3.3	1.1	8.0	12.0	Q2

TAPE AND REEL BOX DIMENSIONS

*All dimensions are nominal

Device	Package Type	Package Drawing	Pins	SPQ	Length (mm)	Width (mm)	Height (mm)
BQ25300RTER	WQFN	RTE	16	3000	367.0	367.0	35.0
BQ25300RTER	WQFN	RTE	16	3000	367.0	367.0	35.0

GENERIC PACKAGE VIEW

RTE 16

WQFN - 0.8 mm max height

3 x 3, 0.5 mm pitch

PLASTIC QUAD FLATPACK - NO LEAD

This image is a representation of the package family, actual package may vary.
Refer to the product data sheet for package details.



4225944/A



SIDE WALL METAL THICKNESS DIM A	
OPTION 1	OPTION 2
0.1	0.2



4219117/B 04/2022

NOTES:

1. All linear dimensions are in millimeters. Any dimensions in parenthesis are for reference only. Dimensioning and tolerancing per ASME Y14.5M.
2. This drawing is subject to change without notice.
3. The package thermal pad must be soldered to the printed circuit board for thermal and mechanical performance.

EXAMPLE BOARD LAYOUT

RTE0016C

WQFN - 0.8 mm max height

PLASTIC QUAD FLATPACK - NO LEAD

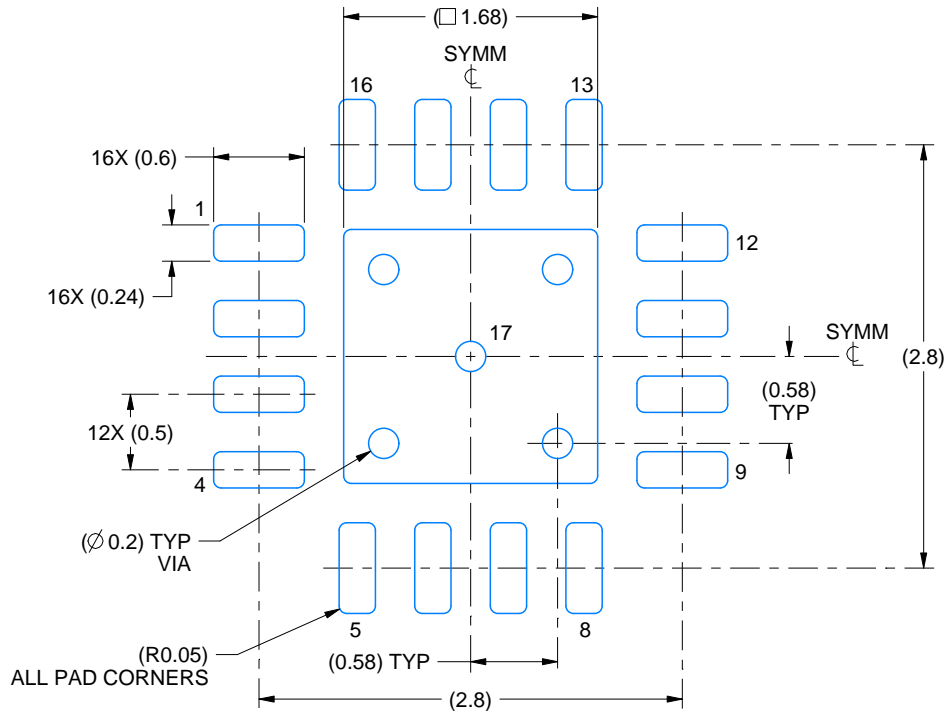

LAND PATTERN EXAMPLE
EXPOSED METAL SHOWN
SCALE:20X



SOLDER MASK DETAILS

4219117/B 04/2022

NOTES: (continued)

- This package is designed to be soldered to a thermal pad on the board. For more information, see Texas Instruments literature number SLUA271 (www.ti.com/lit/slua271).
- Vias are optional depending on application, refer to device data sheet. If any vias are implemented, refer to their locations shown on this view. It is recommended that vias under paste be filled, plugged or tented.

EXAMPLE STENCIL DESIGN

RTE0016C

WQFN - 0.8 mm max height

PLASTIC QUAD FLATPACK - NO LEAD



SOLDER PASTE EXAMPLE
BASED ON 0.125 mm THICK STENCIL

EXPOSED PAD 17:
85% PRINTED SOLDER COVERAGE BY AREA UNDER PACKAGE
SCALE:25X

4219117/B 04/2022

NOTES: (continued)

6. Laser cutting apertures with trapezoidal walls and rounded corners may offer better paste release. IPC-7525 may have alternate design recommendations.

重要なお知らせと免責事項

TI は、技術データと信頼性データ(データシートを含みます)、設計リソース(リファレンス デザインを含みます)、アプリケーションや設計に関する各種アドバイス、Web ツール、安全性情報、その他のリソースを、欠陥が存在する可能性のある「現状のまま」提供しており、商品性および特定目的に対する適合性の黙示保証、第三者の知的財産権の非侵害保証を含むいかなる保証も、明示的または黙示的にかかわらず拒否します。

これらのリソースは、TI 製品を使用する設計の経験を積んだ開発者への提供を意図したものです。(1) お客様のアプリケーションに適した TI 製品の選定、(2) お客様のアプリケーションの設計、検証、試験、(3) お客様のアプリケーションに該当する各種規格や、その他のあらゆる安全性、セキュリティ、規制、または他の要件への確実な適合に関する責任を、お客様のみが単独で負うものとし、

上記の各種リソースは、予告なく変更される可能性があります。これらのリソースは、リソースで説明されている TI 製品を使用するアプリケーションの開発の目的でのみ、TI はその使用をお客様に許諾します。これらのリソースに関して、他の目的で複製することや掲載することは禁止されています。TI や第三者の知的財産権のライセンスが付与されている訳ではありません。お客様は、これらのリソースを自身で使用した結果発生するあらゆる申し立て、損害、費用、損失、責任について、TI およびその代理人を完全に補償するものとし、TI は一切の責任を拒否します。

TI の製品は、[TI の販売条件](#)、[TI の総合的な品質ガイドライン](#)、[ti.com](#) または TI 製品などに関連して提供される他の適用条件に従い提供されます。TI がこれらのリソースを提供することは、適用される TI の保証または他の保証の放棄の拡大や変更を意味するものではありません。TI がカスタム、またはカスタマー仕様として明示的に指定していない限り、TI の製品は標準的なカタログに掲載される汎用機器です。

お客様がいかなる追加条項または代替条項を提案する場合も、TI はそれらに異議を唱え、拒否します。

Copyright © 2025, Texas Instruments Incorporated

最終更新日：2025 年 10 月