

# BQ2407xT 電力パスと電圧ベースの TS を搭載したスタンドアロンの 1セル、1.5A リニア・バッテリー充電器

## 1 特長

- USB 充電器に完全準拠
- 100mA と 500mA を選択可能な最大入力電流
- 100mA の最大電流制限による USB-IF 規格への確実な準拠
- 入力に基づく動的電源管理 ( $V_{IN-DPM}$ ) による低品質 USB 電源に対する保護
- 28V の入力定格、過電圧保護機能付き
- システムへの電力供給とバッテリーの充電を同時に独立して行う動的電力パス管理 (DPPM) 機能を内蔵
- バッテリー電圧に追従するシステム出力 (BQ24072T)
- 電流監視出力 (ISET) により最大 1.5A の充電電流に対応
- AC アダプタのための最大 1.5A のプログラム可能な入力電流制限
- SYSOFF 入力によるバッテリー切断機能
- 逆電流、短絡、過熱保護
- 柔軟な電圧ベースの NTC サーミスタ入力
- 独自のスタートアップ・シーケンスによる突入電流の制限
- ステータス表示 - 充電中 / 完了、パワーグッド
- 3mm x 3mm の小型 16 ピン VQFN パッケージ

## 2 アプリケーション

- スマートフォン
- PDA
- MP3 プレーヤ
- 低消費電力のハンドヘルド・デバイス

## 3 概要

BQ2407xT シリーズのデバイスは、スペースに制約のある携帯型アプリケーションを対象とした統合型リチウムイオン・リニア充電器およびシステム電力パス管理デバイスです。これらのデバイスは USB ポートまたは AC アダプタで動作し、最大 1.5A の充電電流をサポートしています。過電圧保護機能を備えた入力は入力電圧範囲が広いため、レギュレートされていないアダプタにも対応できます。USB 入力電流制限の優れた精度とスタートアップ・シーケンスにより、BQ2407xT は USB-IF の突入電流仕様を満たすことができます。また、入力動的電源管理 ( $V_{IN-DPM}$ ) は、誤って構成された USB 電源に充電器が損傷を与えるのを防止します。

### 製品情報<sup>(1)</sup>

型番	パッケージ	本体サイズ (公称)
BQ24072T	VQFN (16)	3.00mm×3.00mm
BQ24075T		
BQ24079T		

(1) 利用可能なすべてのパッケージについては、このデータシートの末尾にある注文情報を参照してください。

### 概略回路図

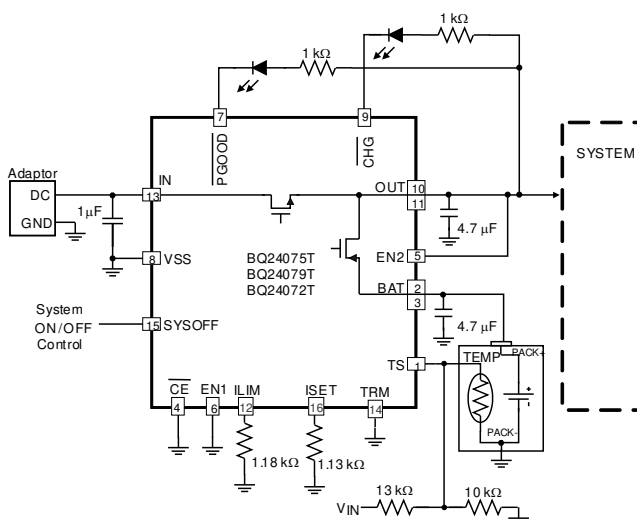

## 目次

1	特長	1	9.4	Device Functional Modes	21
2	アプリケーション	1	<b>10</b>	<b>Applications and Implementation</b>	<b>26</b>
3	概要	1	10.1	Application Information	26
4	改訂履歴	2	10.2	Typical Applications	26
5	概要 (続き)	4	<b>11</b>	<b>Power Supply Recommendations</b>	<b>32</b>
6	Device Options	4	11.1	Power On	32
7	Pin Configuration and Functions	5	<b>12</b>	<b>Layout</b>	<b>34</b>
8	Specifications	7	12.1	Layout Guidelines	34
8.1	Absolute Maximum Ratings	7	12.2	Layout Example	34
8.2	ESD Ratings	7	12.3	Thermal Package	35
8.3	Recommended Operating Conditions	7	<b>13</b>	<b>デバイスおよびドキュメントのサポート</b>	<b>36</b>
8.4	Thermal Information	8	13.1	デバイス・サポート	36
8.5	Electrical Characteristics	8	13.2	関連リンク	36
8.6	Typical Characteristics	11	13.3	ドキュメントの更新通知を受け取る方法	36
<b>9</b>	<b>Detailed Description</b>	<b>14</b>	13.4	サポート・リソース	36
9.1	Overview	14	13.5	商標	36
9.2	Functional Block Diagram	14	13.6	静電気放電に関する注意事項	36
9.3	Feature Description	15	13.7	Glossary	36
			<b>14</b>	<b>メカニカル、パッケージ、および注文情報</b>	<b>36</b>

## 4 改訂履歴

資料番号末尾の英字は改訂を表しています。その改訂履歴は英語版に準じています。

Revision B (November 2014) から Revision C に変更	Page
• データシートのタイトルを変更	1
• Moved Storage temperature From: the <i>ESD table</i> to the <i>Absolute Maximum Ratings</i>	7
• Changed the <i>Handling Ratings</i> table to <i>ESD Ratings</i>	7
• Changed $V_{IN-LOW}$ To: $I_{IN-DPM}$ in the <i>Electrical Characteristics Power Path</i> section	8
• Changed $V_{IN-LOW}$ To $V_{IN-DPM}$ in the <i>Functional Block Diagram</i>	14
• Changed: "R3 must be added.." To: "R8 must be added..." in the <i>Battery Pack Temperature Monitoring</i> section	21
• Changed R6 From: 10 k $\Omega$ To: 19.1 k $\Omega$ and R7 From: 13.2 k $\Omega$ To: 8.25 k $\Omega$ in <a href="#">Figure 23</a>	26
• Changed text: "which for this case are R6 = 8.25 k $\Omega$ and R7 = 19.1k $\Omega$ .." To: "which for this case are R7 = 8.25 k $\Omega$ and R6 = 19.1 k $\Omega$ "	27
• Changed <a href="#">Equation 8</a>	35

Revision A (April 2010) から Revision B に変更	Page
•	1
• Deleted text from the Pin Configuration and Functions section: "Pin out designations are not final. Subject to change."	5
• Changed $V_{O(REG)}$ to $V_{BAT(REG)}$ in Min Typ Max columns on the $V_{RCH}$ spec. of <i>Electrical Characteristics</i> table under sub section BATTERY CHARGER	9
• Changed $I_{OUT}$ 5.5 V To $V_{OUT}$ 5.5 V in <a href="#">Figure 28</a>	28

2009年12月発行のものから更新	Page
• データシートのヘッダーに BQ24072T デバイスを追加	1
• 特長に BQ24072T の箇条書き項目を追加	1
• グラフィック・エンティティに "BQ24072T" を追加	1

---

• Added BQ24072T spec. to Ordering Info table .....	4
• Added BQ24072T Pin Diagram .....	5
• Added BQ24072T to $V_{O(REG)}$ in the <i>Electrical Characteristics</i> Power Path section .....	8
• Added "BQ24072T" to $V_{DPPM}$ in the <i>Electrical Characteristics</i> table.....	9
• Added "BQ24072T" to $V_{BAT(REG)}$ the <i>Electrical Characteristics</i> table.....	9
• Added BQ24072T Termination Disable (TD) description .....	18
• Added graphic entity for BQ24072T DPPM and Battery Supplement Modes .....	24
• Added graphic entity for BQ24072T Host Controlled Charger application.....	30
• Added Termination Disable operation procedure.....	30

---

## 5 概要 (続き)

BQ2407xT は、システムへの電力供給とバッテリーの充電を同時に独立して行う動的電力パス管理 (DPPM) 機能を備えています。入力電流制限によってシステムの出力がDPPMスレッシュホールドまで低下すると、DPPM回路によって充電電流が減少します。これにより、充電電流を個別に監視しながら、常時システム負荷への電源供給が可能です。この機能によって、バッテリーの充放電サイクル数が減り、充電を適切に終了できます。また、欠陥のあるバッテリー・パックが使用された場合や、バッテリー・パックがない場合でも動作可能になります。

さらに、レギュレートされたシステム入力により、完全に放電されたバッテリーであっても、接続後直ちにシステムを起動できます。この電力パス管理アーキテクチャでは、アダプタがシステムのピーク電流を供給できないとき、システム電流の要件を満たすためにバッテリーを補助として使用できるため、アダプタを小型化できます。

バッテリーの充電は、コンディショニング、定電流、定電圧の 3 フェーズで行われます。これらすべての充電フェーズで、内部制御ループにより IC 接合部の温度が監視され、内部の温度スレッシュホールドを超えた場合は充電電流が引き下げられます。充電器の電源段と充電電流センス機能は完全に統合されています。充電器には、高精度の電流および電圧レギュレーション・ループ、充電ステータスの表示、および充電終了の機能があります。入力電流制限および充電電流は、外付け抵抗を使用してプログラミング可能です。

## 6 Device Options

PART NO.	V <sub>OVP</sub>	V <sub>BAT(REG)</sub>	V <sub>OUT(REG)</sub>	V <sub>DPPM</sub>	OPTIONAL FUNCTION
BQ24072TRGTR	6.6 V	4.2 V	V <sub>BAT</sub> + 225 mV	V <sub>OREG</sub> -100 mV	TD
BQ24072TRGTT	6.6 V	4.2 V	V <sub>BAT</sub> + 225 mV	V <sub>OREG</sub> -100 mV	TD
BQ24075TRGTR	6.6 V	4.2 V	5.5 V	4.3 V	SYSOFF
BQ24075TRGTT	6.6 V	4.2 V	5.5 V	4.3 V	SYSOFF
BQ24079TRGTR	6.6 V	4.1 V	5.5 V	4.3 V	SYSOFF
BQ24079TRGTT	6.6 V	4.1 V	5.5 V	4.3 V	SYSOFF

## 7 Pin Configuration and Functions

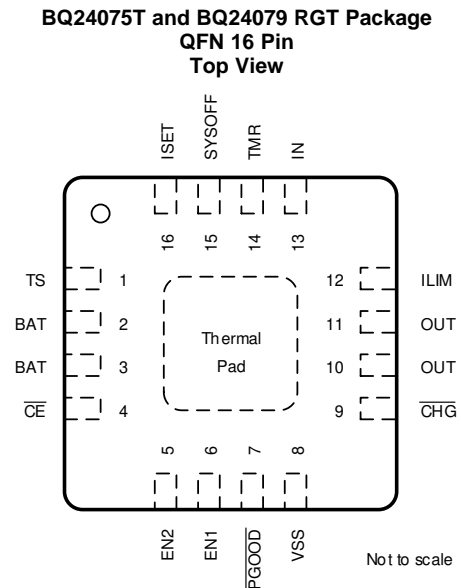
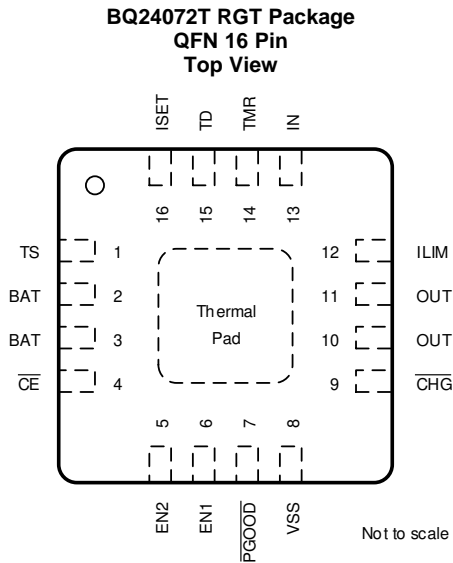

### Pin Functions

NAME	PIN		I/O	DESCRIPTION
	NUMBER			
	BQ24072T	BQ24075T BQ24079T		
TS	1	1	I/O	External NTC Thermistor Input. Connect the TS input to the center tap of a resistor divider from $V_{IN}$ to GND with the NTC in parallel with the bottom resistor to monitor the NTC in the battery pack. For applications that do not utilize the TS function, set the resistor divider to be a 20% ratio. See the Battery Pack Temperature Monitoring section for details on calculating the resistor values.
BAT	2, 3	2, 3	I/O	Charger Power Stage Output and Battery Voltage Sense Input. Connect BAT to the positive terminal of the battery. Bypass BAT to VSS with a 4.7 $\mu$ F to 47 $\mu$ F ceramic capacitor.
$\overline{CE}$	4	4	I	Charge Enable Active-Low Input. Connect $\overline{CE}$ to a high logic level to place the battery charger in standby mode. In standby mode, OUT is active and battery supplement mode is available. Connect $\overline{CE}$ to a low logic level to enable the battery charger. $\overline{CE}$ is internally pulled down with $\sim$ 285k $\Omega$ . Do not leave $\overline{CE}$ unconnected to ensure proper operation.
EN2	5	5	I	Input Current Limit Configuration Inputs. Use EN1 and EN2 to control the maximum input current and enable USB compliance. See for the description of the operation states. EN1 and EN2 are internally pulled down with $\sim$ 285k $\Omega$ . Do not leave EN1 or EN2 unconnected to ensure proper operation.
EN1	6	6	I	
$\overline{PGOOD}$	7	7	O	Open-Drain Power Good Status Indication Output. $\overline{PGOOD}$ pulls to VSS when a valid input source is detected. $\overline{PGOOD}$ is high-impedance when the input power is not within specified limits. Connect $\overline{PGOOD}$ to the desired logic voltage rail using a 1k $\Omega$ to 100k $\Omega$ resistor, or use with an LED for visual indication.
VSS	8	8	–	Ground. Connect to the thermal pad and to the ground rail of the circuit.
$\overline{CHG}$	9	9	O	Open-Drain Charging Status Indication Output. $\overline{CHG}$ pulls to VSS when the battery is charging. $\overline{CHG}$ is high-impedance when charging is complete or when the charger is disabled. $\overline{CHG}$ flashes to indicate a timer fault. Connect $\overline{CHG}$ to the desired logic voltage rail using a 1k $\Omega$ to 100k $\Omega$ resistor, or use with an LED for visual indication.
OUT	10, 11	10, 11	O	System Supply Output. OUT provides a regulated output when the input is below the OVP threshold and above the regulation voltage. When the input is out of the operation range, OUT is connected to VBAT except when SYSOFF is high. Connect OUT to the system load. Bypass OUT to VSS with a 4.7 $\mu$ F to 47 $\mu$ F ceramic capacitor.
ILIM	12	12	O	Adjustable Current Limit Programming Input. Connect a 1.07k $\Omega$ to 7.5k $\Omega$ resistor from ILIM to VSS to program the maximum input current (EN2=1, EN1=0). The input current includes the system load and the battery charge current. Leaving ILIM unconnected disables all charging.
IN	13	13	I	Input Power Connection. Connect IN to the external DC supply (AC adapter or USB port). The input operating range is 4.35V to 6.6V. The input accepts voltages up to 26V without damage, but operation is suspended. Bypass IN to VS with a 1 $\mu$ F to 10 $\mu$ F ceramic capacitor.
TMR	14	14	I	Timer Programming Input. TMR controls the pre-charge and fast-charge safety timers. Connect TMR to VSS to disable all safety timers. Connect a 18k $\Omega$ to 72k $\Omega$ resistor between TMR and VSS to program the timers to a desired length. Leave TMR unconnected to set the timers to the default values.

**Pin Functions (continued)**

PIN			I/O	DESCRIPTION
NAME	NUMBER			
	BQ24072T	BQ24075T BQ24079T		
SYSOFF	–	15	I	System Enable Input. Connect SYSOFF high to turn off the FET connecting the battery to the system output. When an adapter is connected, charge is also disabled. Connect SYSOFF low for normal operation. SYSOFF is internally pulled up to VBAT through a large resistor (~5M $\Omega$ ). Do not leave SYSOFF unconnected to ensure proper operation.
TD	15	–	I	Termination Disable Input. Connect TD high to disable charger termination. Connect TD to VSS to enable charger termination. TD is checked during startup only and cannot be changed during operation. See the TD section in this datasheet for a description of the behavior when termination is disabled. TD is internally pulled down to VSS with ~285 k $\Omega$ . Do not leave TD unconnected to ensure proper operation.
ISET	16	16	I/O	Fast Charge Current Programming Input. Connect a 590 $\Omega$ to 3 k $\Omega$ resistor from ISET to VSS to program the fast charge current level. Charging is disabled if ISET is left unconnected. While charging, the voltage ISET reflects the actual charging current and can be used to monitor charge current. See the Charge Current Translator section of this datasheet for more details.
Thermal Pad	–	--	–	There is an internal electrical connection between the exposed thermal pad and the VSS pin of the device. The thermal pad must be connected to the same potential as the VSS pin on the printed circuit board. Do not use the thermal pad as the primary ground input for the device. VSS must be connected to ground at all times.

**Table 1. EN1/EN2 Settings**

EN2	EN1	MAXIMUM INPUT CURRENT INTO IN
0	0	100 mA. USB100 mode
0	1	500 mA. USB500 mode
1	0	Set by external resistor from ILIM to VSS
1	1	Standby (USB suspend mode)

## 8 Specifications

### 8.1 Absolute Maximum Ratings<sup>(1) (2)</sup>

over operating free-air temperature range (unless otherwise noted)

		MIN	MAX	UNIT
Input voltage	IN (with respect to VSS)	-0.3	28	V
	BAT (with respect to VSS)	-0.3	5	V
	OUT, EN1, EN2, $\overline{CE}$ , TS, ISET, $\overline{PGOOD}$ , $\overline{CHG}$ , ILIM, VREF, ITERM, SYSOFF, TD (with respect to VSS)	-0.3	7	V
Input current	IN		1.6	A
Output current (Continuous)	OUT		5	A
	BAT (Discharge mode)		5	A
	BAT (Charging mode)		1.5	A
Output sink current	$\overline{CHG}$ , $\overline{PGOOD}$		15	mA
Junction temperature, $T_J$		-40	150	°C
Storage temperature, $T_{stg}$		-65	150	°C

- Stresses beyond those listed under *absolute maximum ratings* may cause permanent damage to the device. These are stress ratings only, and functional operation of the device at these or any other conditions beyond those indicated under *recommended operating conditions* is not implied. Exposure to absolute-maximum-rated conditions for extended periods may affect device reliability.
- The IC operational charging life is reduced to 20,000 hours, when charging at 1.5A and 125°C. The thermal regulation feature reduces charge current if the IC's junction temperature reaches 125°C; thus without a good thermal design the maximum programmed charge current may not be reached.

### 8.2 ESD Ratings

			VALUE	UNIT
$V_{(ESD)}$	Electrostatic discharge	Human body model (HBM), per ANSI/ESDA/JEDEC JS-001, all pins <sup>(1)</sup>	±2000	V
		Charged device model (CDM), per JEDEC specification JESD22-C101, all pins <sup>(2)</sup>	±500	V

- JEDEC document JEP155 states that 500-V HBM allows safe manufacturing with a standard ESD control process.
- JEDEC document JEP157 states that 250-V CDM allows safe manufacturing with a standard ESD control process.

### 8.3 Recommended Operating Conditions

over operating free-air temperature range (unless otherwise noted)

		MIN	MAX	UNITS
$V_{IN}$	IN voltage range	4.35	26	V
	IN operating voltage range	4.35	6.4	V
$I_{IN}$	Input current, IN pin		1.5	A
$I_{OUT}$	Current, OUT pin		4.5	A
$I_{BAT}$	Current, BAT pin (Discharging)		4.5	A
$I_{CHG}$	Current, BAT pin (Charging)		1.5 <sup>(1)</sup>	A
$T_J$	Junction Temperature	0	125	°C
$R_{ILIM}$	Maximum input current programming resistor	1.07	7.5	kΩ
$R_{ISET}$	Fast-charge current programming resistor <sup>(2)</sup>	590	3000	Ω
$R_{ITERM}$	Termination current programming resistor	0	15	kΩ
$R_{TMR}$	Timer programming resistor	18	72	kΩ

- The IC operational charging life is reduced to 20,000 hours, when charging at 1.5A and 125°C. The thermal regulation feature reduces charge current if the IC's junction temperature reaches 125°C; thus without a good thermal design the maximum programmed charge current may not be reached.
- Use a 1% tolerance resistor R<sub>ISET</sub> to avoid issues with the R<sub>ISET</sub> short test when using the maximum charge current setting.

## 8.4 Thermal Information

THERMAL METRIC <sup>(1)</sup>		RGT [VQFN]	UNIT
		16 PINS	
R <sub>θJA</sub>	Junction-to-ambient thermal resistance	45.8	°C/W
R <sub>θJC(top)</sub>	Junction-to-case (top) thermal resistance	53.6	°C/W
R <sub>θJB</sub>	Junction-to-board thermal resistance	18.1	°C/W
ψ <sub>JT</sub>	Junction-to-top characterization parameter	1.1	°C/W
ψ <sub>JB</sub>	Junction-to-board characterization parameter	18.0	°C/W
R <sub>θJC(bot)</sub>	Junction-to-case (bottom) thermal resistance	5.2	°C/W

(1) For more information about traditional and new thermal metrics, see the *IC Package Thermal Metrics* application report, [SPRA953](#).

## 8.5 Electrical Characteristics

Over junction temperature range (0°C < T<sub>J</sub> < 125°C) and the recommended supply voltage range (unless otherwise noted)

PARAMETER		TEST CONDITIONS	MIN	TYP	MAX	UNIT
<b>INPUT</b>						
V <sub>UVLO</sub>	Under-voltage lock-out	V <sub>IN</sub> : 0V → 4V	3.2	3.3	3.4	V
V <sub>HYS-UVLO</sub>	Hysteresis on UVLO	V <sub>IN</sub> : 4V → 0V	200		300	mV
V <sub>IN-DT</sub>	Input power detection threshold	(Input power detected if V <sub>IN</sub> > V <sub>BAT</sub> + V <sub>IN-DT</sub> ) V <sub>BAT</sub> = 3.6V, V <sub>IN</sub> : 3.5V → 4V	55	80	140	mV
V <sub>HYS-INDT</sub>	Hysteresis on V <sub>IN-DT</sub>	V <sub>BAT</sub> = 3.6V, V <sub>IN</sub> : 4V → 3.5V	20			mV
t <sub>DGL(PGOOD)</sub>	Deglitch time, input power detected status	Time measured from V <sub>IN</sub> : 0V → 5V, 1μs rise-time to PGOOD = LO		1.2		ms
V <sub>OVP</sub>	Input overvoltage protection threshold	V <sub>IN</sub> : 5V → 7V	6.4	6.6	6.8	V
V <sub>HYS-OVP</sub>	Hysteresis on OVP	V <sub>IN</sub> : 7V → 5V		240		mV
t <sub>BLK(OVP)</sub>	Input over-voltage blanking time			50		μs
t <sub>REC(OVP)</sub>	Input over-voltage recovery time	Time measured from V <sub>IN</sub> : 11V → 5V 1μs fall-time to PGOOD = LO		1.2		ms
<b>ILIM, ISET SHORT CIRCUIT TEST</b>						
I <sub>SC</sub>	Current source			1.3		mA
V <sub>SC</sub>				520		mV
<b>QUIESCENT CURRENT</b>						
I <sub>BAT(PDWN)</sub>	Sleep current into BAT pin	CE = LO or HI, input power not detected, no load on OUT pin			6.5	μA
I <sub>IN(STDBY)</sub>	Standby current into IN pin	EN1 = HI, EN2 = HI, V <sub>IN</sub> ≤ 6V EN1 = HI, EN2 = HI, V <sub>IN</sub> > 6V			50 200	μA
I <sub>CC</sub>	Active supply current, IN pin	CE = LO, V <sub>IN</sub> = 6V, no load on OUT pin, V <sub>BAT</sub> > V <sub>BAT(REG)</sub> , (EN1, EN2) ≠ (HI, HI)			1.5	mA
<b>POWER PATH</b>						
V <sub>DO(IN-OUT)</sub>	V <sub>IN</sub> - V <sub>OUT</sub>	V <sub>IN</sub> = 4.3V, I <sub>IN</sub> = 1A, V <sub>BAT</sub> = 4.2V		300	475	mV
V <sub>DO(BAT-OUT)</sub>	V <sub>BAT</sub> - V <sub>OUT</sub>	I <sub>OUT</sub> = 1A, V <sub>IN</sub> = 0V, V <sub>BAT</sub> > 3V		50	100	mV
V <sub>O(REG)</sub>	OUT pin voltage regulation (BQ24072T)	V <sub>IN</sub> > V <sub>OUT</sub> + V <sub>DO(IN-OUT)</sub> , V <sub>BAT</sub> < 3.2 V	3.3	3.4	3.5	V
		V <sub>IN</sub> > V <sub>OUT</sub> + V <sub>DO(IN-OUT)</sub> , V <sub>BAT</sub> ≥ 3.2 V	V <sub>BAT</sub> + 150 mV	V <sub>BAT</sub> + 225 mV	V <sub>BAT</sub> + 270 mV	
	OUT pin voltage regulation (BQ24075T, BQ24079T)	V <sub>IN</sub> > V <sub>OUT</sub> + V <sub>DO(IN-OUT)</sub>	5.4	5.5	5.6	
I <sub>IN-MAX</sub>	Maximum input current	EN1 = LO, EN2 = LO	90	95	100	mA
		EN1 = HI, EN2 = LO	450	475	500	mA
		EN2 = HI, EN1 = LO	K <sub>ILIM</sub> /R <sub>ILIM</sub>			A
K <sub>ILIM</sub>	Maximum input current factor	ILIM ≥ 500mA	1500	1600	1700	AΩ
		200mA < ILIM < 500mA	1330	1512	1700	
I <sub>IN-MAX</sub>	Programmable input current limit range	EN2 = HI, EN1 = LO, R <sub>ILIM</sub> = 8kΩ to 1.1kΩ	200		1500	mA
V <sub>IN-DPM</sub>	Input voltage threshold when input current is reduced	EN2 = LO, EN1 = X	4.35	4.5	4.63	V



**Electrical Characteristics (continued)**

 Over junction temperature range ( $0^{\circ}\text{C} < T_J < 125^{\circ}\text{C}$ ) and the recommended supply voltage range (unless otherwise noted)

PARAMETER		TEST CONDITIONS	MIN	TYP	MAX	UNIT
$V_{DPPM}$	Output voltage threshold when charging current is reduced	BQ24072T	$V_{O(REG)}$ –180 mV	$V_{O(REG)}$ –100 mV	$V_{O(REG)}$ –30 mV	V
		BQ24075T, BQ24079T	4.2	4.3	4.4	
$V_{BSUP1}$	Enter battery supplement mode	VOUT falling, Supplement mode entered when $V_{OUT} < V_{BSUP1}$		$V_{BAT} - 40\text{mV}$		V
$V_{BSUP2}$	Exit battery supplement mode	VOUT rising, Supplement mode exited when $V_{OUT} > V_{BSUP2}$		$V_{BAT} - 20\text{mV}$		V
$V_{O(SC1)}$	Output short-circuit detection threshold, power-on		0.8	0.9	1.0	V
$V_{O(SC2)}$	Output short-circuit detection threshold, supplement mode $V_{BAT} - V_{OUT} > V_{O(SC2)}$ indicates short-circuit		200	250	300	mV
$t_{DGL(SC2)}$	Deglintch time, supplement mode short circuit			250		$\mu\text{s}$
$t_{REC(SC2)}$	Recovery time, supplement mode short circuit			60		ms
<b>BATTERY CHARGER</b>						
$I_{BAT(SC)}$	Source current for BAT pin short-circuit detection		4	7.5	11	mA
$V_{BAT(SC)}$	BAT pin short-circuit detection threshold		1.6	1.8	2.0	V
$V_{BAT(REG)}$	Battery charge voltage	BQ24072T, BQ24075T	4.16	4.20	4.24	V
		BQ24079T	4.059	4.100	4.141	
$V_{LOWV}$	Pre-charge to fast-charge transition threshold		2.9	3	3.1	V
$t_{DGL1(LOWV)}$	Deglintch time on pre-charge to fast-charge transition			25		ms
$t_{DGL2(LOWV)}$	Deglintch time on fast-charge to pre-charge transition			25		ms
$I_{CHG}$	Battery fast charge current range	$V_{BAT(REG)} > V_{BAT} > V_{LOWV}$ , $V_{IN} = 5\text{V}$ , $\overline{CE} = \text{LO}$ , $\text{EN1} = \text{LO}$ , $\text{EN2} = \text{HI}$	300		1500	mA
$I_{CHG}$	Battery fast charge current	$\overline{CE} = \text{LO}$ , $\text{EN1} = \text{LO}$ , $\text{EN2} = \text{HI}$ , $V_{BAT} > V_{LOWV}$ , $V_{IN} = 5\text{V}$ , $I_{IN-MAX} > I_{CHG}$ , no load on OUT pin, thermal loop not active, DPM loop not active		$K_{ISET}/R_{ISET}$		A
$K_{ISET}$	Fast charge current factor		797	890	975	$A\Omega$
$I_{PRECHG}$	Pre-charge current			$K_{PRECHG}/R_{ISET}$		A
$k_{PRECHG}$	Pre-charge current factor		70	88	106	
$I_{TERM}$	Charge current value for termination detection threshold	$\overline{CE} = \text{LO}$ , $(\text{EN1}, \text{EN2}) \neq (\text{LO}, \text{LO})$ , $V_{BAT} > V_{RCH}$ , $t < t_{MAXCH}$ , $V_{IN} = 5\text{V}$ , DPM loop not active, thermal loop not active	$0.09 \times I_{CHG}$	$0.1 \times I_{CHG}$	$0.11 \times I_{CHG}$	
		$\overline{CE} = \text{LO}$ , $(\text{EN1}, \text{EN2}) = (\text{LO}, \text{LO})$ , $V_{BAT} > V_{RCH}$ , $t < t_{MAXCH}$ , $V_{IN} = 5\text{V}$ , DPM loop not active, thermal loop not active	$0.027 \times I_{CHG}$	$0.033 \times I_{CHG}$	$0.040 \times I_{CHG}$	
$t_{DGL(TERM)}$	Deglintch time, termination detected			25		ms
$V_{RCH}$	Recharge detection threshold		$V_{BAT(REG)}$ –140mV	$V_{BAT(REG)}$ –100mV	$V_{BAT(REG)}$ –60mV	V
$t_{DGL(RCH)}$	Deglintch time, recharge threshold detected			62.5		ms
$t_{DGL(NO-IN)}$	Delay time, input power loss to charger turn-off	$V_{BAT} = 3.6\text{V}$ . Time measured from $V_{IN}$ : $5\text{V} \rightarrow 3.3\text{V}$ $1\mu\text{s}$ fall-time		20		ms
$I_{BAT(DET)}$	Sink current for battery detection		5	7.5	10	mA
$t_{DET}$	Battery detection timer			250		ms
<b>BATTERY CHARGING TIMERS</b>						
$t_{PRECHG}$	Pre-charge safety timer value	TMR = floating	1440	1800	2160	s
$t_{MAXCH}$	Charge safety timer value	TMR = floating	14400	18000	21600	s
$t_{PRECHG}$	Pre-charge safety timer value(externally set)	$18\text{k}\Omega < R_{TMR} < 72\text{k}\Omega$		$R_{TMR} \times K_{TMR}$		s

**Electrical Characteristics (continued)**

 Over junction temperature range ( $0^{\circ}\text{C} < T_J < 125^{\circ}\text{C}$ ) and the recommended supply voltage range (unless otherwise noted)

PARAMETER		TEST CONDITIONS	MIN	TYP	MAX	UNIT
$t_{\text{MAXCH}}$	Charge safety timer value (externally set)	$18\text{k}\Omega < R_{\text{TMR}} < 72\text{k}\Omega$	$10 \times R_{\text{TMR}} \times K_{\text{TMR}}$			s
$K_{\text{TMR}}$	Timer factor		35	45	55	s / $\text{k}\Omega$
<b>BATTERY – PACK NTC MONITOR</b>						
$V_{\text{HOT}}$	High temperature trip point	Battery charging	12	12.5	13	% of $V_{\text{IN}}$
$V_{\text{HYS(HOT)}}$	Hysteresis on high trip point	Battery charging		1		% of $V_{\text{IN}}$
$V_{\text{COLD}}$	Low temperature trip point	Battery charging	24.5	25	25.5	% of $V_{\text{IN}}$
$V_{\text{HYS(COLD)}}$	Hysteresis on low trip point	Battery charging		1		% of $V_{\text{IN}}$
$t_{\text{DGL(TS)}}$	Deglintch time, pack temperature fault detection	Battery charging		50		ms
<b>THERMAL REGULATION</b>						
$T_{\text{J(REG)}}$	Temperature Regulation Limit			125		$^{\circ}\text{C}$
$T_{\text{J(OFF)}}$	Thermal shutdown temperature			155		$^{\circ}\text{C}$
$T_{\text{J(OFF-HYS)}}$	Thermal shutdown hysteresis			20		$^{\circ}\text{C}$
<b>LOGIC LEVELS ON EN1, EN2, <math>\overline{\text{CE}}</math>, SYSOFF, TD</b>						
$V_{\text{IL}}$	Logic LOW input voltage		0		0.4	V
$V_{\text{IH}}$	Logic HIGH input voltage		1.4		6.0	V
$I_{\text{IL}}$					1	$\mu\text{A}$
$I_{\text{IH}}$					10	$\mu\text{A}$
<b>LOGIC LEVELS ON <math>\overline{\text{PGOOD}}</math>, <math>\overline{\text{CHG}}</math></b>						
$V_{\text{OL}}$	Output LOW voltage	$I_{\text{SINK}} = 5 \text{ mA}$			0.4	V

### 8.6 Typical Characteristics

$V_{IN} = 6\text{ V}$ ,  $EN1 = 1$ ,  $EN2 = 0$ ,  $T_A = 25^\circ\text{C}$ , unless otherwise noted.

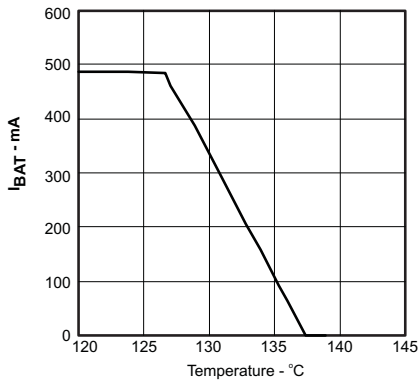

Figure 1. Thermal Regulation

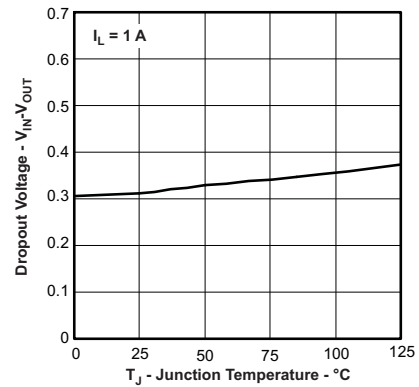

Figure 2. Dropout Voltage vs Temperature

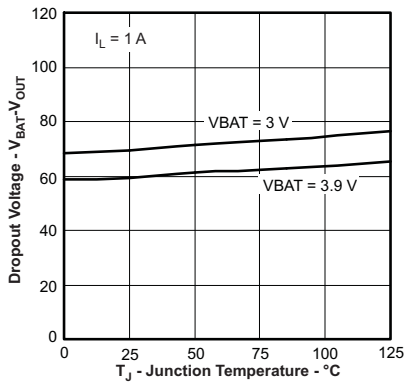

Figure 3. Dropout Voltage vs Temperature

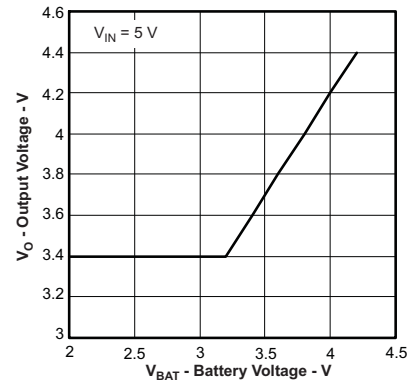

Figure 4. BQ24072T Output Regulation Voltage vs Battery Voltage

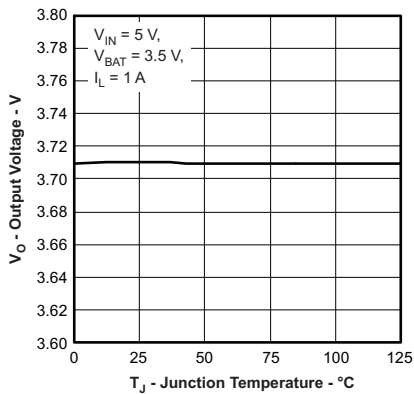

Figure 5. BQ24072T Output Regulation Voltage vs Temperature

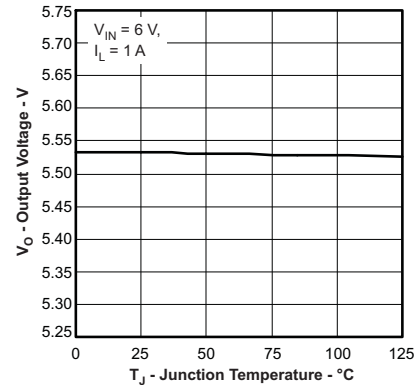
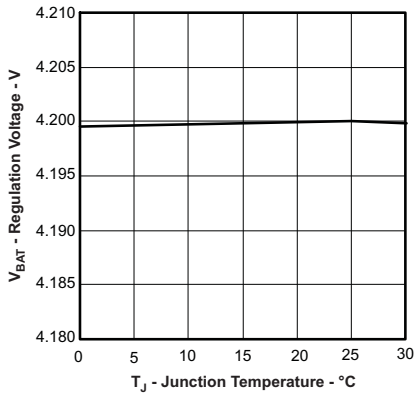
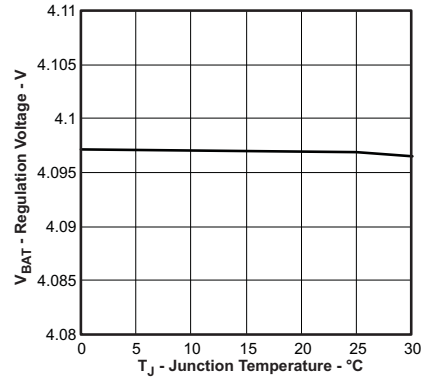
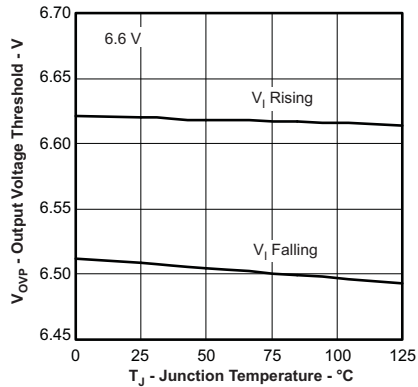
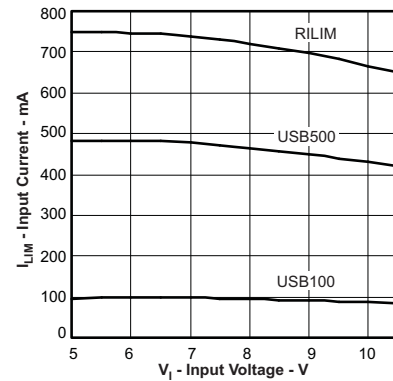
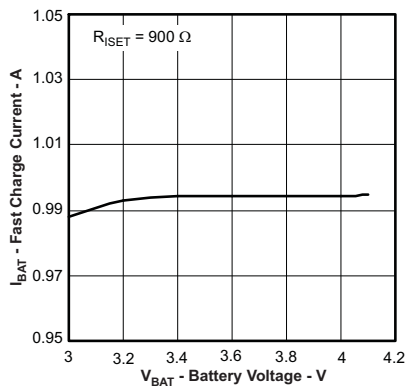
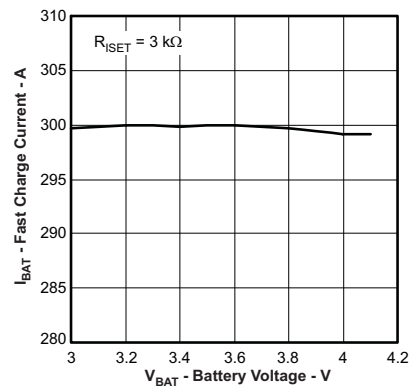
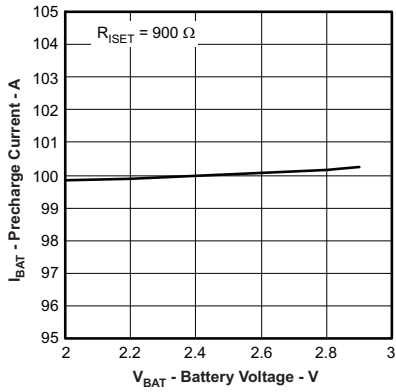

Figure 6. Output Regulation Voltage vs Temperature

**Typical Characteristics (continued)**
 $V_{IN} = 6\text{ V}$ ,  $EN1 = 1$ ,  $EN2 = 0$ ,  $T_A = 25^\circ\text{C}$ , unless otherwise noted.

**Figure 7. BQ24075T BAT Regulation Voltage vs Temperature**

**Figure 8. BQ24079T Battery Regulation Voltage vs Temperature**

**Figure 9. Overvoltage Protection Threshold vs Temperature**

**Figure 10. Input Current Limit vs Input Voltage**

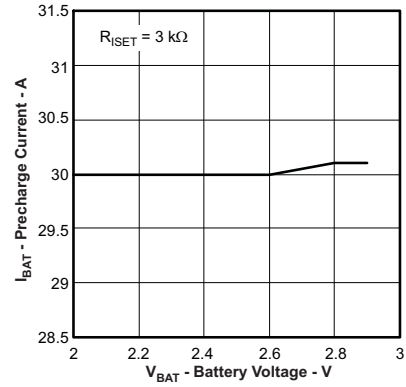
**Figure 11. Fastcharge Current vs Battery Voltage**

**Figure 12. Fastcharge Current vs Battery Voltage**

**Typical Characteristics (continued)**

$V_{IN} = 6\text{ V}$ ,  $EN1 = 1$ ,  $EN2 = 0$ ,  $T_A = 25^\circ\text{C}$ , unless otherwise noted.



**Figure 13. Fastcharge Current vs Battery Voltage**



**Figure 14. Precharge Current vs Battery Voltage**

## 9 Detailed Description

### 9.1 Overview

The BQ2407x devices are integrated Li-Ion linear chargers and system power path management devices targeted at space-limited portable applications. The device powers the system while simultaneously and independently charging the battery. This feature reduces the number of charge and discharge cycles on the battery, allows for proper charge termination and enables the system to run with a defective or absent battery pack. It also allows instant system turn-on even with a totally discharged battery. The input power source for charging the battery and running the system can be an AC adapter or a USB port. The devices feature Dynamic Power Path Management (DPPM), which shares the source current between the system and battery charging, and automatically reduces the charging current if the system load increases. When charging from a USB port, the input dynamic power management ( $V_{IN-DPM}$ ) circuit reduces the input current if the input voltage falls below a threshold, preventing the USB port from crashing. The power-path architecture also permits the battery to supplement the system current requirements when the adapter cannot deliver the peak system currents.

### 9.2 Functional Block Diagram

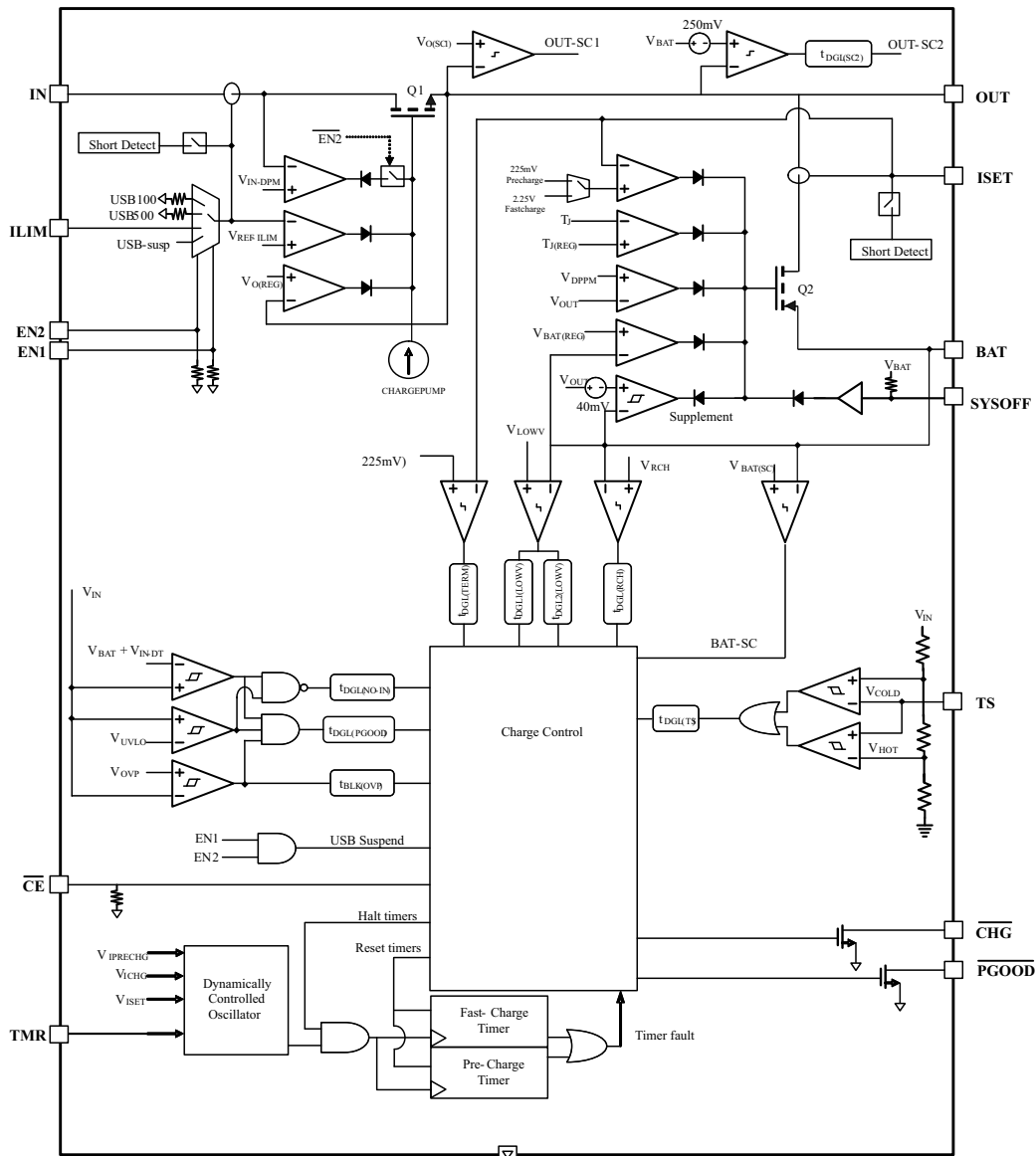

### 9.3 Feature Description

#### 9.3.1 Undervoltage Lockout (UVLO)

The BQ2407X family remains in power down mode when the input voltage at the IN pin is below the undervoltage threshold (UVLO). During the power down mode the host commands at the control inputs ( $\overline{\text{CE}}$ , EN1 and EN2) are ignored. The Q1 FET connected between IN and OUT pins is off, and the status outputs,  $\overline{\text{CHG}}$  and  $\overline{\text{PGOOD}}$ , are high impedance. The Q2 FET that connects BAT to OUT is ON. (If SYSOFF is high, Q2 is off). During power down mode, the VOUT(SC2) circuitry is active and monitors for overload conditions on OUT.

#### 9.3.2 Overvoltage Protection (OVP)

The BQ2407xT accepts inputs up to 28V without damage. Additionally, an overvoltage protection (OVP) circuit is implemented that shuts off the internal LDO and discontinues charging when  $V_{\text{IN}} > V_{\text{OVP}}$  for a period longer than  $t_{\text{DGL(OVP)}}$ . When in OVP, the system output (OUT) is connected to the battery and  $\overline{\text{PGOOD}}$  is high impedance. Once the OVP condition is removed, a new power on sequence starts (See the *POWER ON* section). The safety timers are reset and a new charge cycle will be indicated by the CHG output.

#### 9.3.3 Dynamic Power-Path Management

The BQ2407xT features an OUT output that powers the external load connected to the battery. This output is active whenever a source is connected to IN or BAT. The following sections discuss the behavior of OUT with a source connected to IN to charge the battery and a battery source only.

#### 9.3.4 Battery Charging

Set  $\overline{\text{CE}}$  low to initiate battery charging. First, the device checks for a short-circuit on the BAT pin by sourcing  $I_{\text{BAT(SC)}}$  to the battery and monitoring the voltage. When the BAT voltage exceeds  $V_{\text{BAT(SC)}}$ , the battery charging continues. The battery is charged in three phases: conditioning pre-charge, constant current fast charge (current regulation) and a constant voltage tapering (voltage regulation). In all charge phases, an internal control loop monitors the IC junction temperature and reduces the charge current if an internal temperature threshold is exceeded.

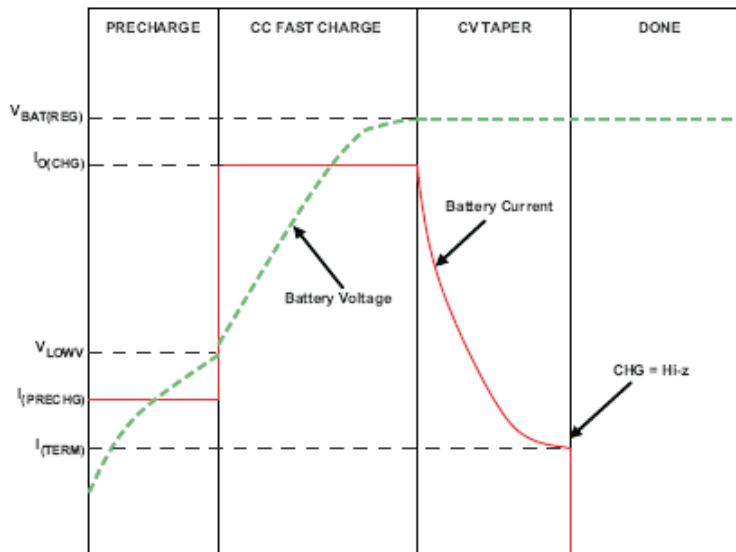

**Figure 15. Typical Charging Cycle**

## Feature Description (continued)

Figure 15 illustrates a normal Li-Ion charge cycle using the BQ2407xT. In the pre-charge phase, the battery is charged at with the pre-charge current ( $I_{PRECHG}$ ). Once the battery voltage crosses the  $V_{LOWV}$  threshold, the battery is charged with the fast-charge current ( $I_{CHG}$ ). As the battery voltage reaches  $V_{BAT(REG)}$ , the battery is held at a constant voltage of  $V_{BAT(REG)}$  and the charge current tapers off as the battery approaches full charge. When the battery current reaches  $I_{TERM}$ , the CHG pin indicates *charging done* by going high-impedance.

Note that termination detection is disabled whenever the charge rate is reduced because of the actions of the thermal loop, the DPPM loop or the  $V_{IN-DPM}$  loop.

The value of the fast-charge current is set by the resistor connected from the ISET pin to VSS, and is given by Equation 1.

$$I_{CHG} = K_{ISET} / R_{ISET} \quad (1)$$

The charge current limit is adjustable up to 1.5A. The valid resistor range is 590Ω to 3 kΩ. Note that if  $I_{CHG}$  is programmed as greater than the input current limit, the battery will not charge at the rate of  $I_{CHG}$ , but at the slower rate of  $I_{IN(MAX)}$  (minus the load current on the OUT pin, if any). In this case, the charger timers will be proportionately slowed down.

### 9.3.5 Charge Current Translator

When the charger is enabled, internal circuits generate a current proportional to the charge current at the ISET input. The current out of ISET is 1/400 ( $\pm 10\%$ ) of the charge current. This current, when applied to the external charge current programming resistor,  $R_{ISET}$ , generates an analog voltage that can be monitored by an external host to calculate the current sourced from BAT.

$$V_{ISET} = I_{CHARGE} / 400 \times R_{ISET} \quad (2)$$



Feature Description (continued)

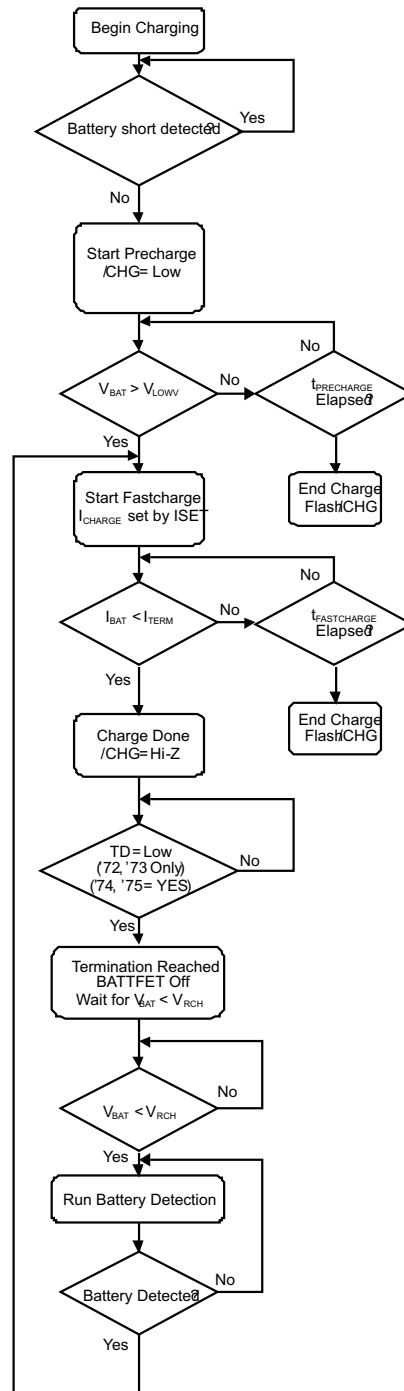

Figure 16. Battery Charging Flow Diagram

## Feature Description (continued)

### 9.3.6 Battery Detection and Recharge

The BQ2407xT automatically detects if a battery is connected or removed. Once a charge cycle is complete, the battery voltage is monitored. When the battery voltage falls below  $V_{RCH}$ , the battery detection routine is run. During battery detection, current ( $I_{BAT(DET)}$ ) is pulled from the battery for a duration  $t_{DET}$  to see if the voltage on BAT falls below  $V_{LOWV}$ . If not, charging begins. If it does, then it indicates that the battery is missing or the protector is open. Next, the precharge current is applied for  $t_{DET}$  to close the protector if possible. If  $V_{BAT} < V_{RCH}$ , then the protector is closed and charging is initiated. If  $V_{BAT} > V_{RCH}$ , then the battery is determined to be missing and the detection routine continues.

### 9.3.7 Termination Disable (TD Input, BQ24072T)

The BQ24072T contains a TD input that allows termination to be enabled/ disabled. Connect TD to a logic high to disable charge termination. When termination is disabled, the device goes through the pre-charge, fast-charge and CV phases, then remains in the CV phase. During the CV phase, the charger maintains the output voltage at BAT equal to  $V_{BAT(REG)}$ , and charging current does not terminate. The charge current is set by  $I_{CHG}$  or  $I_{IN,max}$ , whichever is less. Battery detection is not performed. The  $\overline{CHG}$  output is high impedance once the current falls below  $I_{TERM}$  and does not go low until the input power or  $\overline{CE}$  are toggled. When termination is disabled, the pre-charge and fast-charge safety timers are also disabled.

### 9.3.8 Battery Disconnect (SYSOFF Input)

The BQ24075T and BQ24079T feature a SYSOFF input that allows the user to turn the FET Q2 off and disconnect the battery from the OUT pin. This is useful for disconnecting the system load from the battery, factory programming where the battery is not installed or for host side impedance track fuel gauging, such as BQ27500, where the battery open circuit voltage level must be detected before the battery charges or discharges. The  $\overline{CHG}$  output remains low when SYSOFF is high. Connect SYSOFF to VSS, to turn Q2 on for normal operation. SYSOFF is internally pulled to VBAT through ~5 M $\Omega$  resistor.

### 9.3.9 Dynamic Charge Timers (TMR Input)

The BQ2407xT devices contain internal safety timers for the pre-charge and fast-charge phases to prevent potential damage to the battery and the system. The timers begin at the start of the respective charge cycles. The timer values are programmed by connecting a resistor from TMR to VSS. The resistor value is calculated using the following equation:

$$t_{PRECHG} = K_{TMR} \times R_{TMR}$$

$$t_{MAXCHG} = 10 \times K_{TMR} \times R_{TMR}$$

Leave TMR unconnected to select the internal default timers. Disable the timers by connecting TMR to VSS.

Note that timers are suspended when the device is in thermal shutdown, and the timers are slowed proportionally to the charge current when the device enters thermal regulation.

1. During the fast charge phase, several events increase the timer durations.
2. The system load current activates the DPPM loop which reduces the available charging current
3. The input current is reduced because the input voltage has fallen to  $V_{IN-DPM}$
4. The device has entered thermal regulation because the IC junction temperature has exceeded  $T_{J(REG)}$

During each of these events, the internal timers are slowed down proportionately to the reduction in charging current. For example, if the charging current is reduced by half for two minutes, the timer clock is reduced to half the frequency and the counter counts half as fast resulting in only one minute of "counting" time.

If the precharge timer expires before the battery voltage reaches  $V_{LOWV}$ , the BQ2407xT indicates a fault condition. Additionally, if the battery current does not fall to  $I_{TERM}$  before the fast charge timer expires, a fault is indicated. The  $\overline{CHG}$  output flashes at approximately 2 Hz to indicate a fault condition. The fault condition is cleared by toggling  $\overline{CE}$  or the input power, entering/ exiting USB suspend mode, or an OVP event.

## Feature Description (continued)

### 9.3.10 Status Indicators ( $\overline{\text{PGOOD}}$ , $\overline{\text{CHG}}$ )

The BQ2407xT contains two open-drain outputs that signal its status. The  $\overline{\text{PGOOD}}$  output signals when a valid input source is connected.  $\overline{\text{PGOOD}}$  is low when  $(V_{\text{BAT}} + V_{\text{IN(DT)}}) < V_{\text{IN}} < V_{\text{OVP}}$ . When the input voltage is outside of this range,  $\overline{\text{PGOOD}}$  is high impedance.

The charge cycle after power-up,  $\overline{\text{CE}}$  going low, or exiting OVP is indicated with the  $\overline{\text{CHG}}$  output on (low - LED on), whereas all refresh (subsequent) charges will result in the  $\overline{\text{CHG}}$  output off (open - LED off). In addition, the  $\overline{\text{CHG}}$  signals timer faults by flashing at approximately 2 Hz.

**Table 2.  $\overline{\text{PGOOD}}$  Status Indicator**

INPUT STATE	$\overline{\text{PGOOD}}$ OUTPUT
$V_{\text{IN}} < V_{\text{UVLO}}$	Hi impedance
$V_{\text{UVLO}} < V_{\text{IN}} < V_{\text{IN(DT)}}$	Hi impedance
$V_{\text{IN(DT)}} < V_{\text{IN}} < V_{\text{OVF}}$	Low
$V_{\text{IN}} < V_{\text{OVP}}$	Hi impedance

**Table 3.  $\overline{\text{CHG}}$  Status Indicator**

CHARGE STATE	$\overline{\text{CHG}}$ OUTPUT
Charging	Low (for first charge cycle)
Charging suspended by thermal loop, or DPPM loop	
Safety timers expired	Flashing at 2 Hz
Charging done	Hi impedance
Recharging after termination	
IC disabled or no valid input power	
Battery absent	

### 9.3.11 Thermal Regulation and Thermal Shutdown

The BQ2407xT contain a thermal regulation loop that monitors the die temperature. If the temperature exceeds  $T_{\text{J(REG)}}$ , the device automatically reduces the charging current to prevent the die temperature from increasing further. In some cases, the die temperature continues to rise despite the operation of the thermal loop, particularly under high  $V_{\text{IN}}$  and heavy OUT system load conditions. Under these conditions, if the die temperature increases to  $T_{\text{J(OFF)}}$ , the input FET Q1 is turned OFF. FET Q2 is turned ON to ensure that the battery still powers the load on OUT. Once the device die temperature cools by  $T_{\text{J(OFF-HYS)}}$ , the input FET Q1 is turned on and the device returns to thermal regulation. Continuous overtemperature conditions result in a "hiccup" mode. During thermal regulation, the safety timers are slowed down proportionately to the reduction in current limit.

Note that this feature monitors the die temperature of the BQ2407xT. This is not synonymous with ambient temperature. Self heating exists due to the power dissipated in the IC because of the linear nature of the battery charging algorithm and the LDO associated with OUT. A modified charge cycle with the thermal loop active is shown in [Figure 17](#). Battery termination is disabled during thermal regulation.

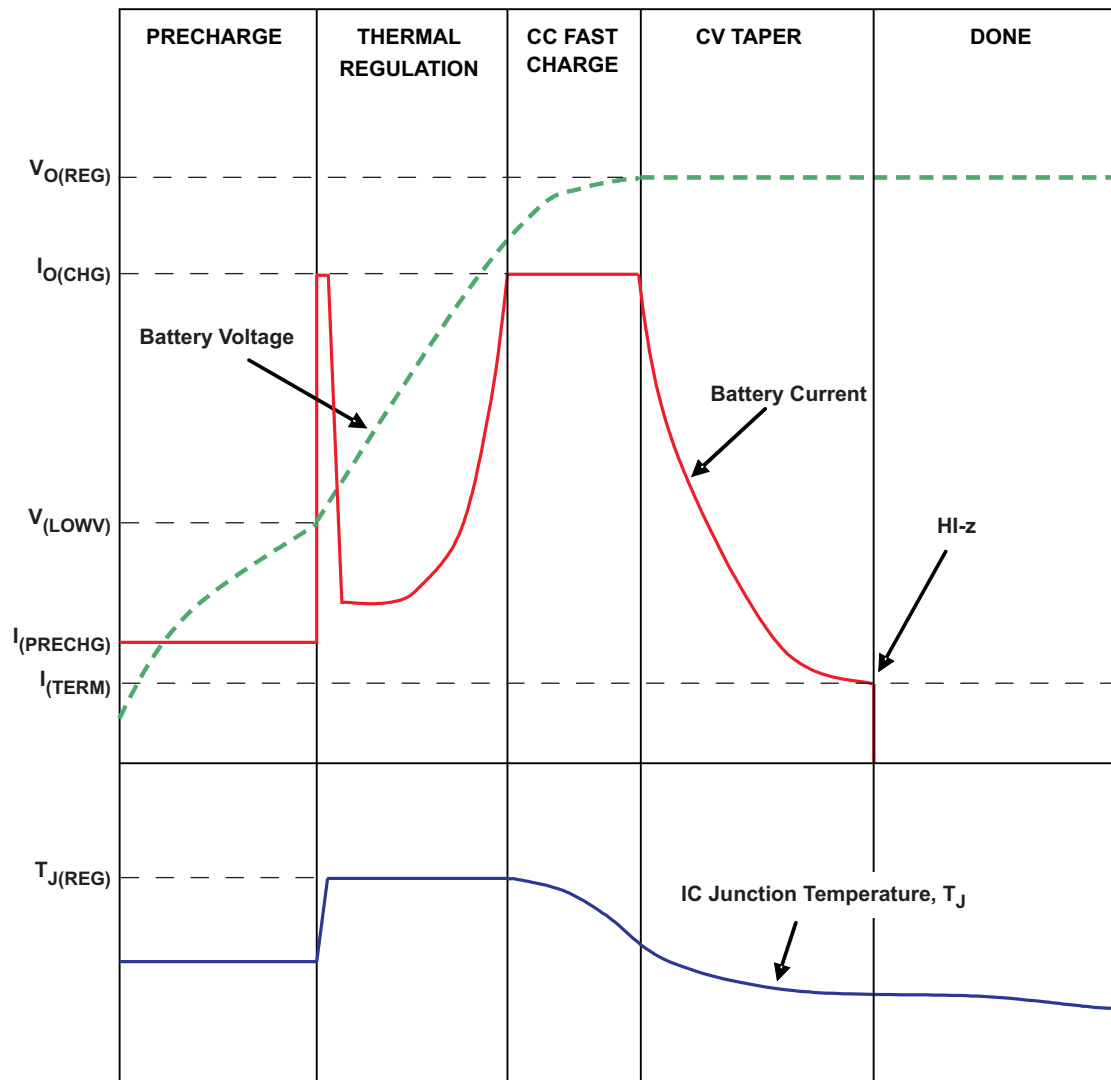
**Figure 17. Charge Cycle Modified by Thermal Loop**

### 9.3.12 Battery Pack Temperature Monitoring

The BQ2407xT features an external battery pack temperature monitoring input. The TS input connects to the NTC thermistor in the battery pack to monitor battery temperature and prevent dangerous over-temperature conditions. During charging, the voltage at TS is continuously monitored. If, at any time, the voltage at TS is outside of the operating range ( $V_{COLD}$  to  $V_{HOT}$ ), charging is suspended. The timers maintain their values but suspend counting. When the voltage measured at TS returns to within the operation window, charging is resumed and the timers continue counting. When charging is suspended due to a battery pack temperature fault, the CHG output remains low and continues to indicate charging.

$$R6 = \frac{\frac{V_{IN}}{V_{COLD}} - 1}{1 + \frac{1}{R7 + RCOLD}} \quad (3)$$

$$R7 = \frac{V_{IN} \times RCOLD \times RHOT \times \left[ \frac{1}{V_{COLD}} - \frac{1}{V_{HOT}} \right]}{RHOT \times \left[ \frac{V_{IN}}{V_{HOT}} - 1 \right] - RCOLD \times \left[ \frac{V_{IN}}{V_{COLD}} - 1 \right]} \quad (4)$$

Where:

$$V_{\text{COLD}} = 0.25 \times V_{\text{IN}}$$

$$V_{\text{HOT}} = 0.125 \times V_{\text{IN}}$$

R<sub>HOT</sub> is the expected thermistor resistance at the programmed hot threshold, R<sub>COLD</sub> is the expected thermistor resistance at the programmed cold threshold. If the value of R<sub>6</sub> is less than 100 k $\Omega$ , R<sub>8</sub> must be added to protect the IC from 28V inputs. If R<sub>6</sub> is greater than 100 k $\Omega$ , R<sub>8</sub> does not need to be used.

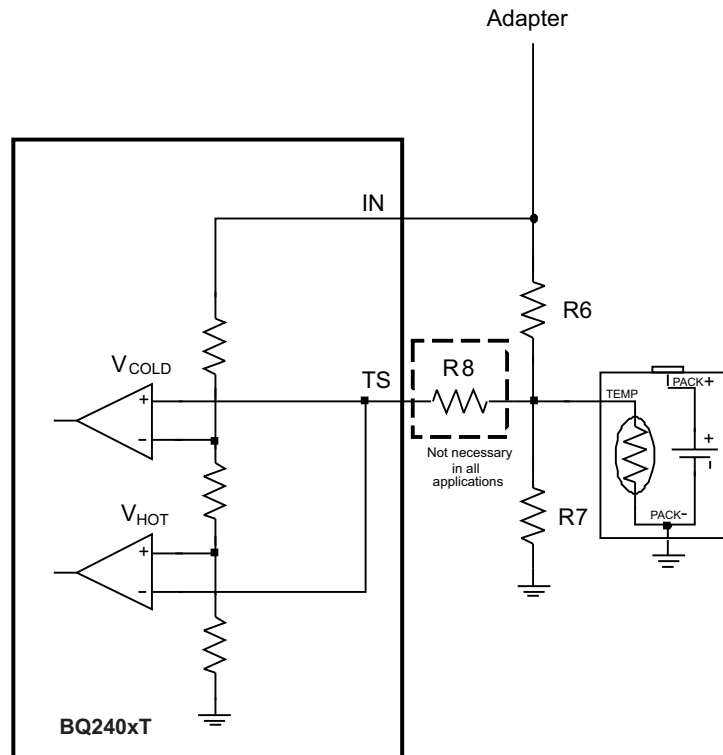

Figure 18. NTC Monitoring Function

For applications that do not require the TS monitoring function, set R<sub>6</sub> = 200 k $\Omega$  and R<sub>7</sub> = 49.9 k $\Omega$  to set the TS voltage at a valid level and maintain charging.

## 9.4 Device Functional Modes

### 9.4.1 Input Source Connected (Adapter or USB)

With a source connected, the dynamic power-path management (DPPM) circuitry of the BQ2407xT monitors the input current continuously. The OUT output for the BQ24075T and BQ24079T is regulated to a fixed voltage ( $V_{\text{O(REG)}}$ ). For the BQ24072T, OUT is regulated to 225 mV above the voltage at BAT. If the BAT voltage is less than 3.2 V, OUT is clamped to 3.4 V. This allows for proper startup of the system load even with a discharged battery. The current into IN is shared between charging the battery and powering the system load at OUT. The BQ2407xT has internal selectable current limits of 100 mA (USB100) and 500 mA (USB500) for charging from USB ports, as well as a resistor-programmable input current limit.

The BQ2407xT is USB IF compliant for the inrush current testing. The USB spec allows up to 10  $\mu\text{F}$  to be hard started, which establishes 50  $\mu\text{C}$  as the maximum inrush charge value when exceeding 100 mA. The input current limit for the BQ2407xT prevents the input current from exceeding this limit, even with system capacitances greater than 10  $\mu\text{F}$ . Note that the input capacitance to the device must be selected small enough to prevent a violation (<10  $\mu\text{F}$ ), as this current is not limited. Figure 19 demonstrates the startup of the BQ2407xT and compares it to the USB-IF specification.

## Device Functional Modes (continued)

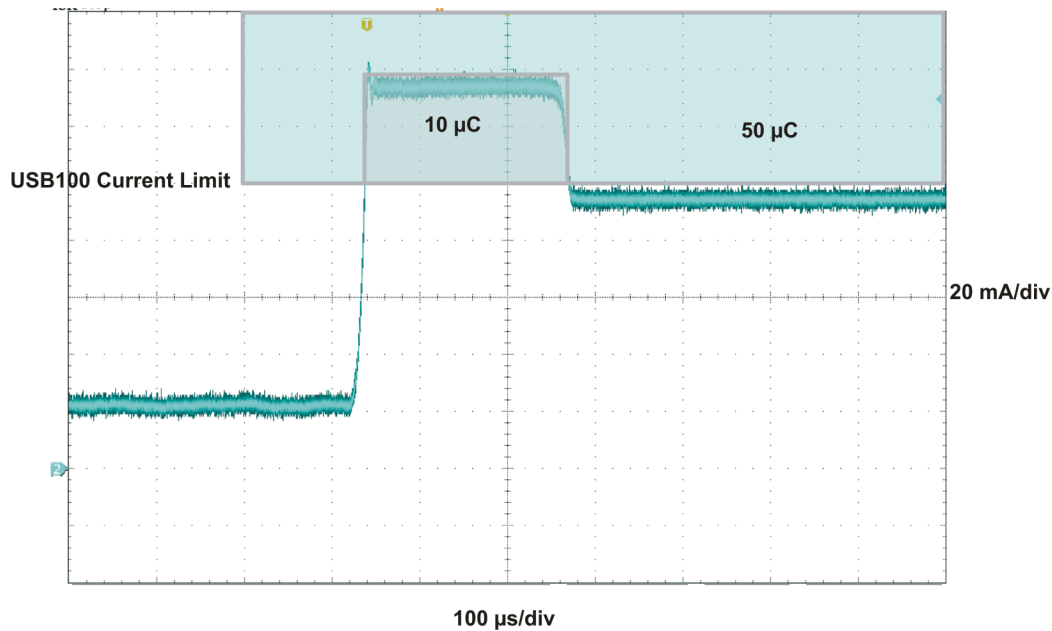

Figure 19. USB-IF Inrush Current Test

The input current limit selection is controlled by the state of the EN1 and EN2 pins as shown in Table 1. When using the resistor-programmable current limit, the input current limit is set by the value of the resistor connected from the ILIM pin to VSS, and is given by the equation:

$$I_{N-MAX} = K_{ILIM} / R_{ILIM} \quad (5)$$

The input current limit is adjustable up to 1.5 A. The valid resistor range is 1.07 kΩ to 7.5 kΩ.

When the IN source is connected, priority is given to the system load. The DPPM and Battery Supplement modes are used to maintain the system load. Figure 21 illustrates an example of the DPPM and supplement modes. These modes are explained in detail in the following sections.

### 9.4.1.1 Input DPM Mode ( $V_{IN-DPM}$ )

The BQ2407xT uses the  $V_{IN-DPM}$  mode for operation from current-limited USB ports. When EN1 and EN2 are configured for USB100 (EN2=0, EN1=0) or USB500 (EN2=0, EN1=1) modes, the input voltage is monitored. If  $V_{IN}$  falls to  $V_{IN-DPM}$ , the input current limit is reduced to prevent the input voltage from falling further. This prevents the BQ2407xT from crashing poorly designed or incorrectly configured USB sources. Figure 20 shows the  $V_{IN-DPM}$  behavior to a current limited source. In this figure, the input source has a 400 mA current limit and the device is in USB500 mode (EN1=1, EN2=0).

## Device Functional Modes (continued)

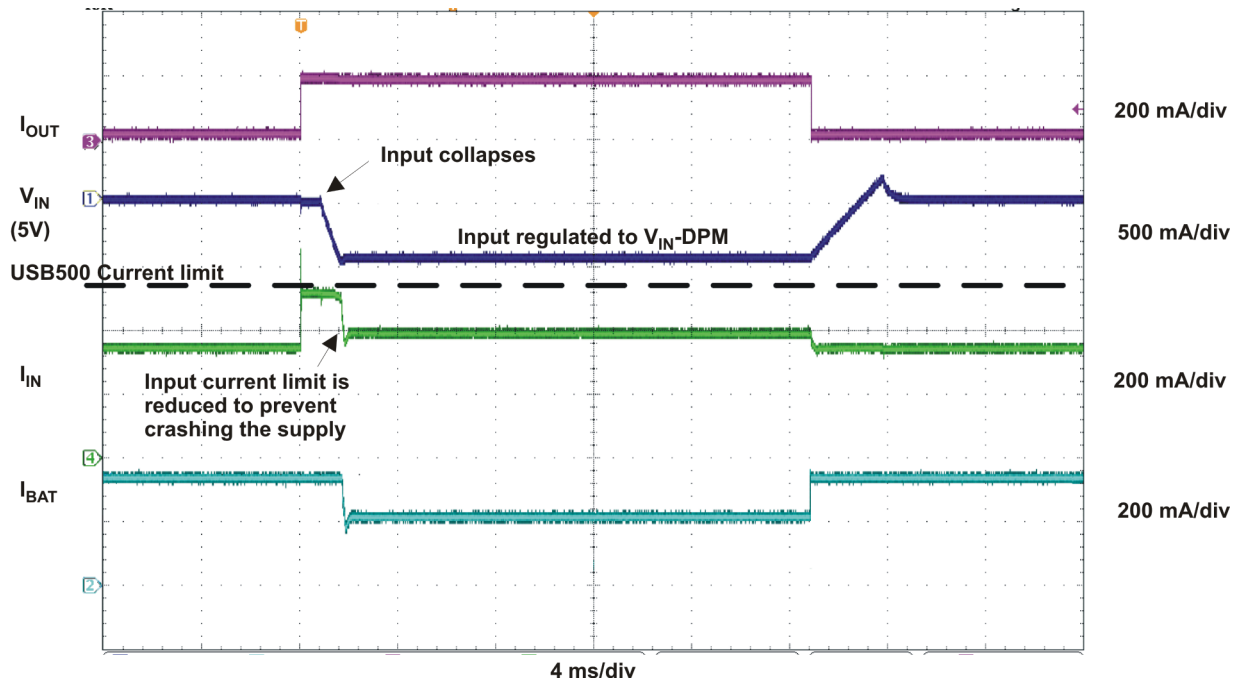

Figure 20.  $V_{IN-DPM}$  Mode

### 9.4.1.2 DPPM Mode

When the sum of the charging and system load currents exceeds the maximum input current (programmed with EN1, EN2 and ILIM pins), the voltage at OUT decreases. Once the voltage on the OUT pin falls to  $V_{DPPM}$ , the BQ2407xT enters DPPM mode. In this mode, the charging current is reduced as the OUT current increases in order to maintain the system output. Battery termination is disabled while in DPPM mode.

### 9.4.1.3 Battery Supplement Mode

While in DPPM mode, if the charging current falls to zero and the system load current increases beyond the programmed input current limit, the voltage at OUT reduces further. When the OUT voltage drops below the  $V_{BSUP1}$  threshold, the battery supplements the system load. The battery stops supplementing the system load when the voltage at OUT rises above the  $V_{BSUP2}$  threshold.

During supplement mode, the battery supplement current is not regulated (BAT-FET is fully on), however there is a short circuit protection circuit built in. demonstrate supplement mode. If during battery supplement mode, the voltage at OUT drops  $V_{O(SC2)}$  below the BAT voltage, the OUT output is turned off if the overload exists after  $t_{DGL(SC2)}$ . The short circuit recovery timer then starts counting. After  $t_{REC(SC2)}$ , OUT turns on and attempts to restart. If the short circuit remains, OUT is turned off and the counter restarts. Battery termination is disabled while in supplement mode.

Device Functional Modes (continued)

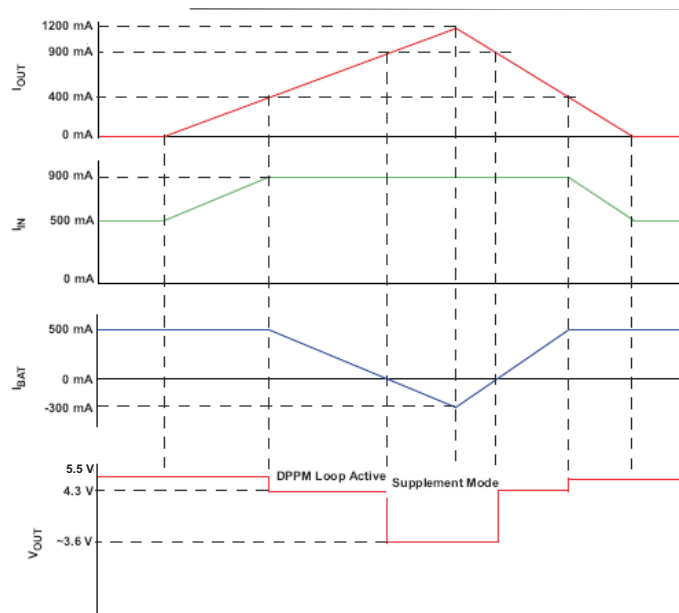

Figure 21. BQ24075T, '79T DPPM and Battery Supplement Modes ( $V_{OREG} = 5.5\text{ V}$ ,  $V_{BAT} = 3.6\text{ V}$ )

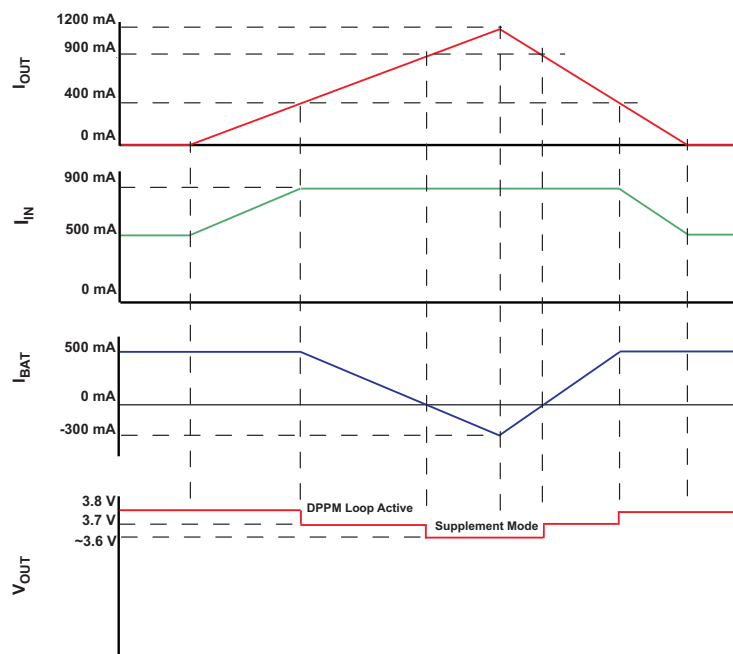

Figure 22. BQ24072T DPPM and Battery Supplement Modes ( $V_{OREG} = V_{BAT} + 225\text{ mV}$ ,  $V_{BAT} = 3.6\text{ V}$ )



## Device Functional Modes (continued)

### 9.4.2 Input Source Not Connected

When no source is connected to the IN input, OUT is powered strictly from the battery. During this mode the current into OUT is not regulated, similar to Battery Supplement Mode, however the short circuit circuitry is active. If the OUT voltage falls below the BAT voltage by 250 mV for longer than  $t_{DGL(SC2)}$ , OUT is turned off. The short circuit recovery timer then starts counting. After  $t_{REC(SC2)}$ , OUT turns on and attempts to restart. If the short circuit remains, OUT is turned off and the counter restarts. This ON/OFF cycle continues until the overload condition is removed.

## 10 Applications and Implementation

### NOTE

Information in the following applications sections is not part of the TI component specification, and TI does not warrant its accuracy or completeness. TI's customers are responsible for determining suitability of components for their purposes. Customers should validate and test their design implementation to confirm system functionality.

### 10.1 Application Information

The BQ2407xT series of devices are integrated Li-ion linear chargers and system power path management devices targeted at space-limited portable applications.

### 10.2 Typical Applications

#### 10.2.1 Using the BQ24075T, BQ24079T to Disconnect the Battery from the System

The BQ24075T and BQ24079T are designed for applications that require the input supply to be passed through to the output (OUT). For these devices, the OUT regulation threshold is set to 5.5 V. For applications with a typical regulation on the adapter of 5 V, the main LDO in the BQ24075T and BQ24079T operates in dropout mode so that OUT is as high as possible to supply downstream devices. The input OVP and regulation threshold on OUT protect downstream devices from faulty or incorrect adapters. The BQ24075T and BQ24079T also contain a SYSOFF input that disconnects the OUT output from the battery to prevent standby loads from draining the battery during long storage intervals. See the "System ON/OFF" section for more details.

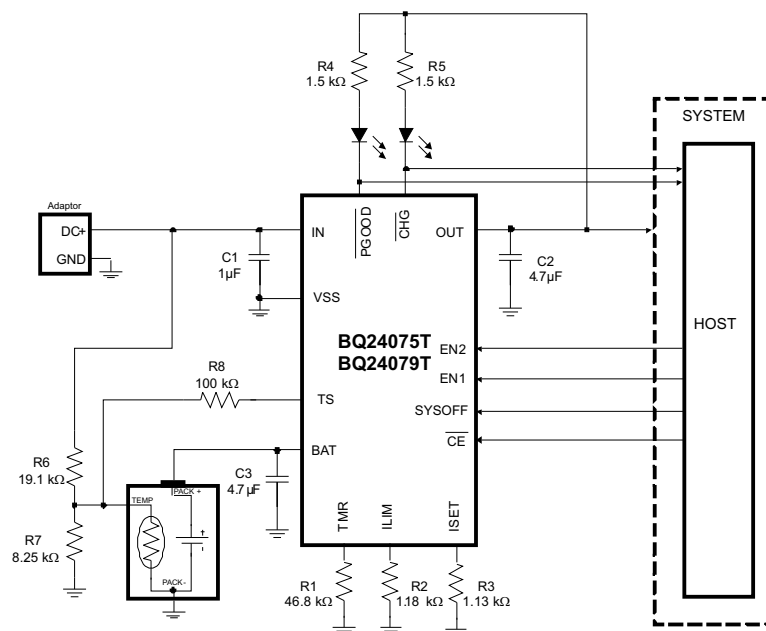

NOTE:  $V_{IN}$  = UVLO to  $V_{OVP}$ ,  $I_{FASTCHG}$  = 800mA,  $I_{IN(MAX)}$  = 1.35A, Battery Temperature Charge Range = 0°C to 50°C, 6.25 hour Fastcharge Safety Timer

**Figure 23. Using the BQ24075T, BQ24079T to Disconnect the Battery from the System**

#### 10.2.1.1 Design Requirements

- Supply voltage = 5 V
- Fast charge current of approximately 800 mA; ISET – pin 16
- Input Current Limit = 1.35 A; ILIM – pin 12
- Safety timer duration, Fast-Charge = 6.25 hours; TMR – pin 14
- Battery Temperature Sense = 10 kΩ; NTC (103AT-2), 0°C to 50°C Operation

## Typical Applications (continued)

### 10.2.1.2 Detailed Design Procedure

#### 10.2.1.2.1 Program the Fast Charge Current (ISET):

- $R_{ISET} = K_{ISET} / I_{CHG}$
- $K_{ISET} = 890 \text{ A}\Omega$ ; from the [Electrical Characteristics](#) table
- $R_{ISET} = 890 \text{ A}\Omega / 0.8 \text{ A} = 1.1125 \text{ k}\Omega$
- Select the closest standard value, which for this case is 1.13 k $\Omega$ . Connect this resistor between ISET (pin 16) and  $V_{SS}$ .

#### 10.2.1.2.2 Program the Input Current Limit (ILIM):

- $R_{ILIM} = K_{ILIM} / I_{IN(MAX)}$
- $K_{ILIM} = 1600 \text{ A}\Omega$ ; from the [Electrical Characteristics](#) table
- $R_{ISET} = 1600 \text{ A}\Omega / 1.35 \text{ A} = 1.19 \text{ k}\Omega$
- Select the closest standard value, which for this case is 1.18 k $\Omega$ . Connect this resistor between ILIM (pin 12) and  $V_{SS}$ .

#### 10.2.1.2.3 Program 6.25-hour Fast-Charge Safety Timer (TMR):

- $R_{TMR} = t_{MAXCHG} / (10 \times K_{TMR})$
- $K_{TMR} = 45 \text{ s/k}\Omega$  from the [Electrical Characteristics](#) table.
- $R_{TMR} = (6.25 \text{ hr} \times 3600 \text{ s/hr}) / (10 \times 45 \text{ s/k}\Omega) = 46.8 \text{ k}\Omega$ ;
- Select the closest standard value, which for this case is 46.4 k $\Omega$ . Connect this resistor between TMR (pin 2) and  $V_{SS}$ .

#### 10.2.1.2.4 TS Function:

Using a 10 k $\Omega$  NTC thermistor in the battery pack (103AT-2). Connect a resistor divider from  $V_{IN}$  to  $V_{SS}$  with the thermistor and TS connected to the center tap (R6 and R7 in [Figure 23](#)).

- $R_{HOT} = 4.086 \text{ k}\Omega$ ; 50°C threshold from NTC data sheet
- $R_{COLD} = 28.16 \text{ k}\Omega$ ; 0°C threshold from NTC data sheet
- $V_{COLD} = 0.25 \times V_{IN} = 0.25 \times 5 \text{ V} = 1.25 \text{ V}$
- $V_{HOT} = 0.125 \times V_{IN} = 0.125 \times 5 \text{ V} = 0.625 \text{ V}$

$$R7 = \frac{V_{IN} \times R_{COLD} \times R_{HOT} \times \left[ \frac{1}{V_{COLD}} - \frac{1}{V_{HOT}} \right]}{R_{HOT} \times \left[ \frac{V_{IN}}{V_{HOT}} - 1 \right] - R_{COLD} \times \left[ \frac{V_{IN}}{V_{COLD}} - 1 \right]} = \frac{5 \times 28160 \times 4086 \times \left[ \frac{1}{1.25} - \frac{1}{0.625} \right]}{4086 \times \left[ \frac{5}{0.625} - 1 \right] - 28160 \times \left[ \frac{5}{1.25} - 1 \right]} = 8.236 \text{ k}\Omega \quad (6)$$

$$R6 = \frac{\frac{V_{IN}}{V_{COLD}} - 1}{\frac{1}{R7} + \frac{1}{R_{COLD}}} = \frac{\frac{5}{1.25} - 1}{\frac{1}{8250} + \frac{1}{28160}} = 19.14 \text{ k}\Omega \quad (7)$$

Since the calculated values for R6 is less than 100 k $\Omega$ , a 100 k $\Omega$  resistor for R8 must be used. Choose the closest standard values, which for this case are R7 = 8.25 k $\Omega$  and R6 = 19.1 k $\Omega$ .

For applications that do not require the TS monitoring function, set R6 = 200 k $\Omega$  and R7 = 49.9 k $\Omega$  to set the TS voltage at a valid level and maintain charging.

#### 10.2.1.2.5 $\overline{\text{CHG}}$ and $\overline{\text{PGOOD}}$ LED Status:

Connect a 1.5 k $\Omega$  resistor in series with a LED between OUT and  $\overline{\text{CHG}}$  to indicate charging status. Connect a 1.5 k $\Omega$  resistor in series with a LED between OUT and  $\overline{\text{PGOOD}}$  to indicate when a valid input source is connected.

## Typical Applications (continued)

### 10.2.1.2.6 Processor Monitoring Status:

Connect a pullup resistor (on the order of 100 k $\Omega$ ) between the processor power rail and  $\overline{\text{CHG}}$  and PGOOD.

### 10.2.1.2.7 System ON/OFF (SYSOFF):

Connect SYSOFF high to disconnect the battery from the system load. Connect SYSOFF low for normal operation.

### 10.2.1.2.8 Selecting IN, OUT and BAT Capacitors

In most applications, all that is needed is a high-frequency decoupling capacitor (ceramic) on the power pin, input, output and battery pins. Using the values shown on the application diagram, is recommended. After evaluation of these voltage signals with real system operational conditions, one can determine if capacitance values can be adjusted toward the minimum recommended values (DC load application) or higher values for fast high amplitude pulsed load applications. Note if designed high input voltage sources (bad adapters or wrong adapters), the capacitor needs to be rated appropriately. Ceramic capacitors are tested to 2x their rated values so a 16 V capacitor may be adequate for a 30 V transient (verify tested rating with capacitor manufacturer).

### 10.2.1.3 Application Curves

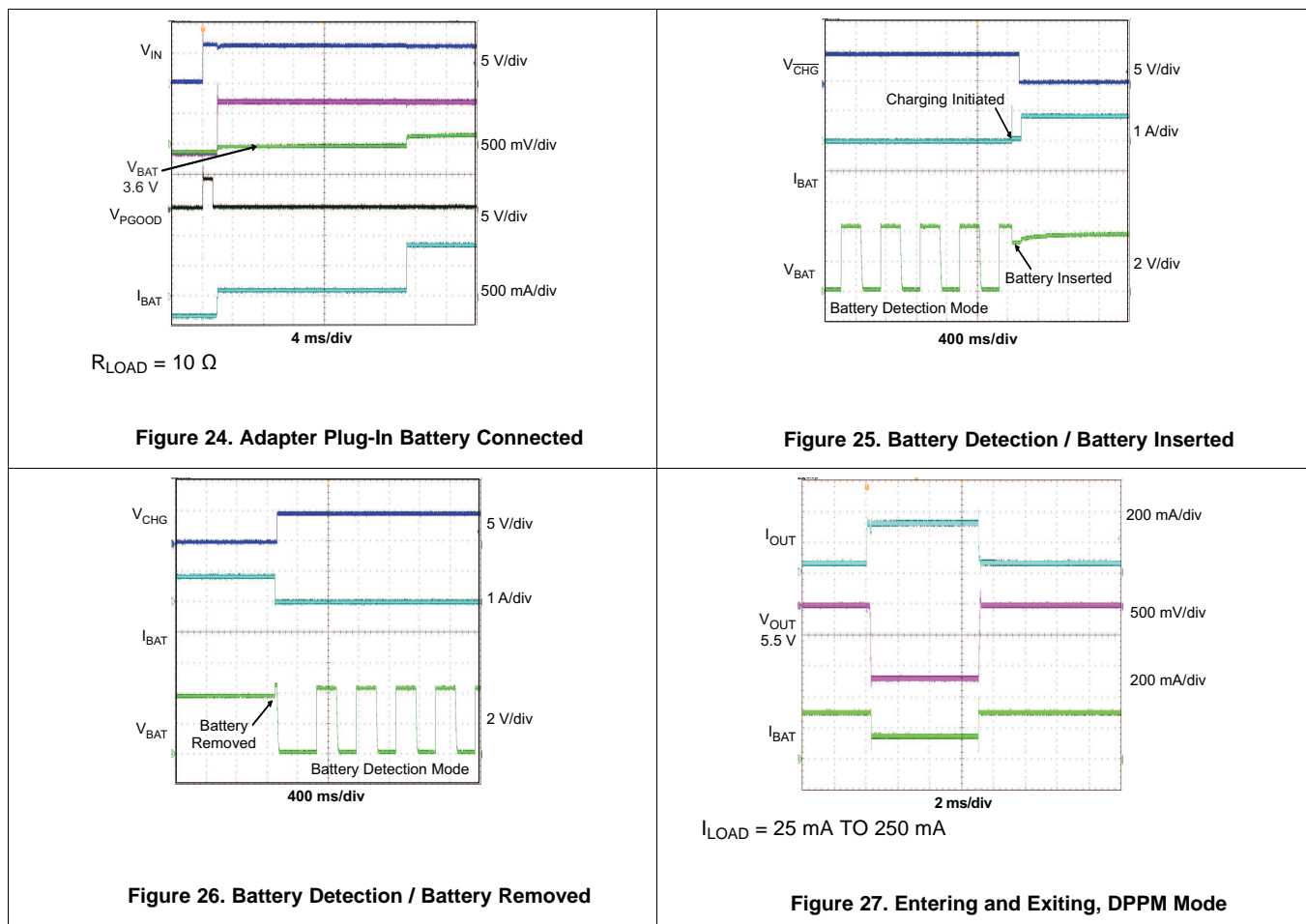

Typical Applications (continued)

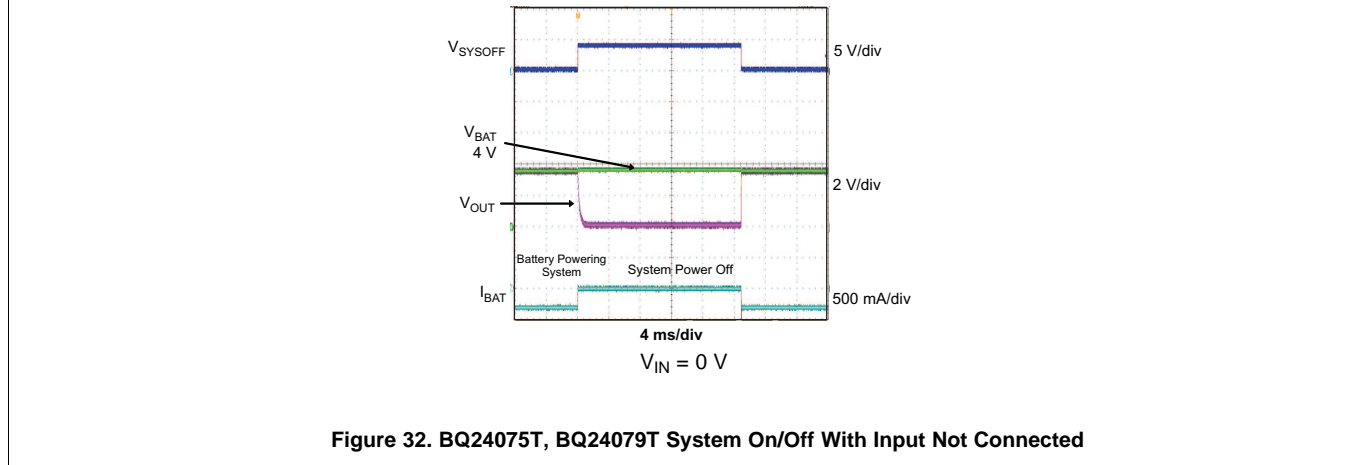
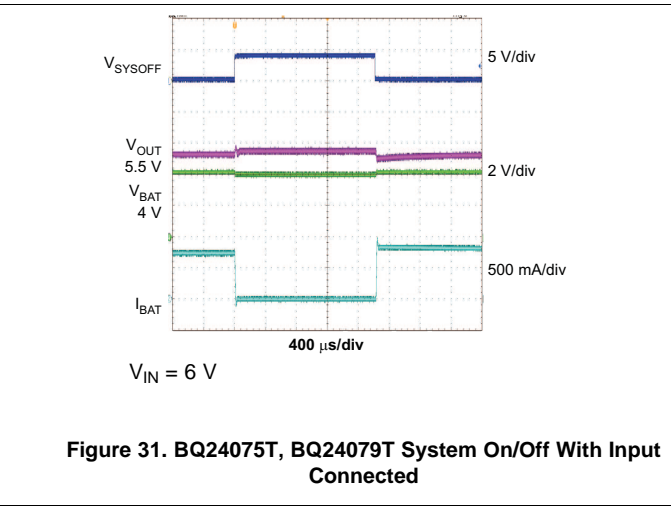
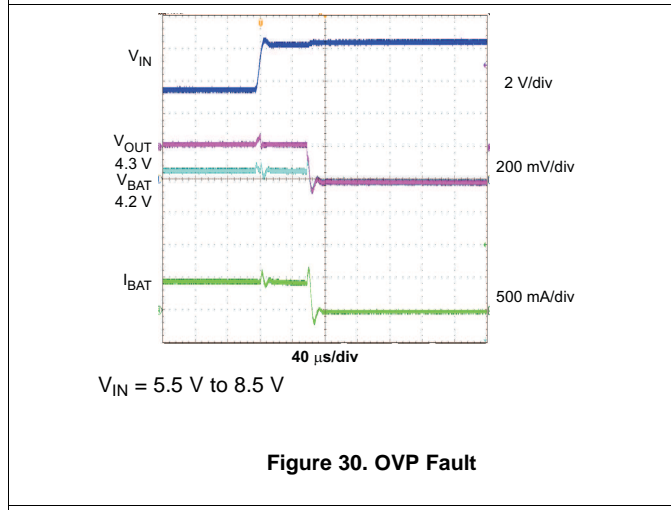
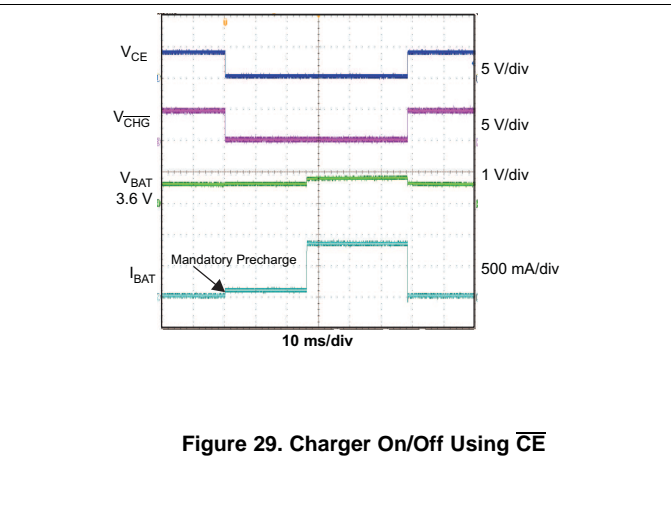
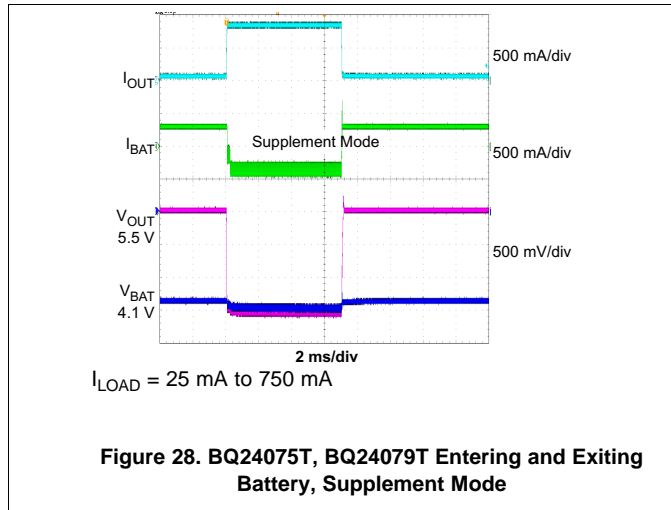

## Typical Applications (continued)

### 10.2.2 BQ24072T in a Host Controlled Charger Application

The BQ24072T is designed for applications that require a lower regulation on the system rail. For BQ24072T, the OUT regulation threshold is set to  $V_{BAT} + 225\text{ mV}$ . The lower regulation point protects downstream devices from the higher voltage on the supply. Additionally, the lower difference between the BAT and OUT outputs decreases the voltage drop during supplement events. The BQ24072T also contains a TD input that enables/disables the termination function. See the [Termination Disable](#) section for more details.

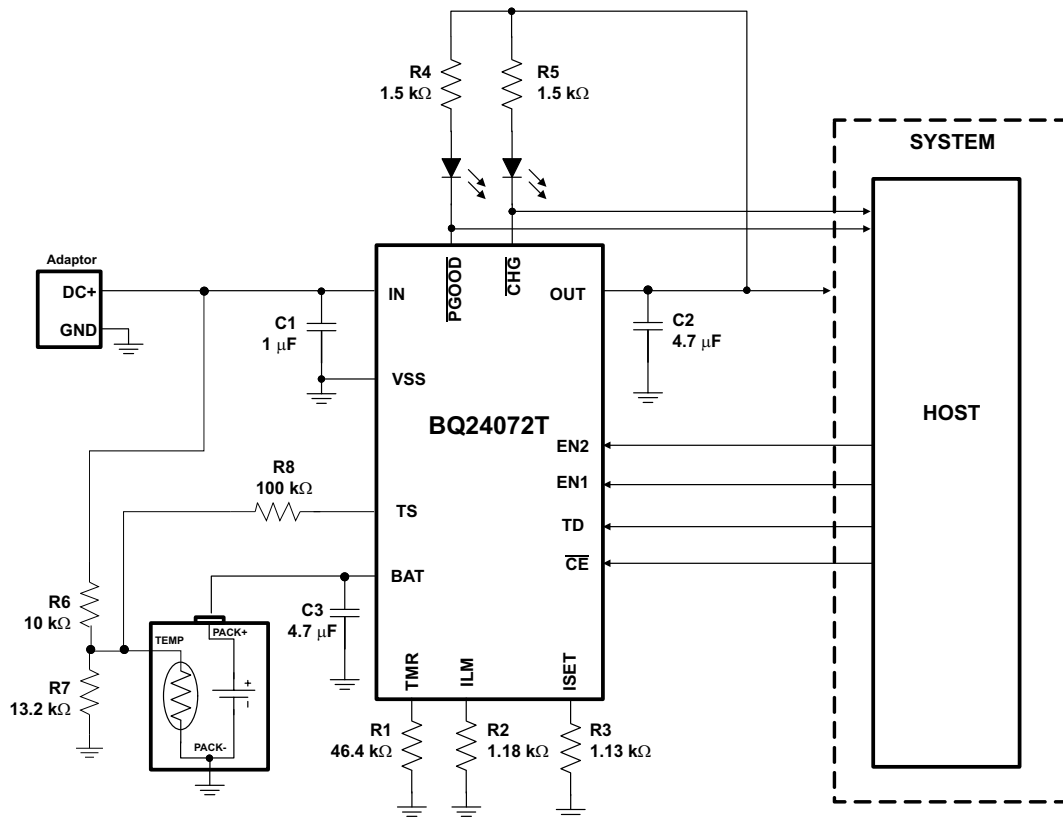

**Figure 33. Using BQ24072T in a Host Controlled Charger Application**

#### 10.2.2.1 Design Requirements

Refer to the [Design Requirements](#) for the Design Requirements.

#### 10.2.2.2 Detailed Design Procedures

Refer to the [Detailed Design Procedure](#) for the Detailed Design Procedures.

##### 10.2.2.2.1 Termination Disable:

Connect TD high to disable termination. Connect TD low to enable termination.

Typical Applications (continued)

10.2.2.3 Application Curves

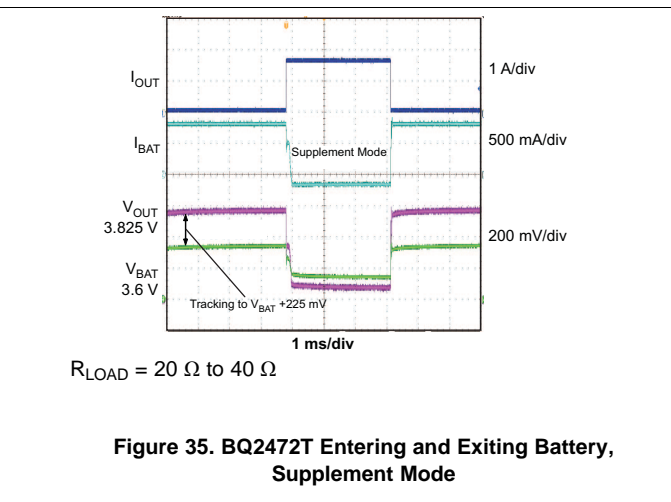
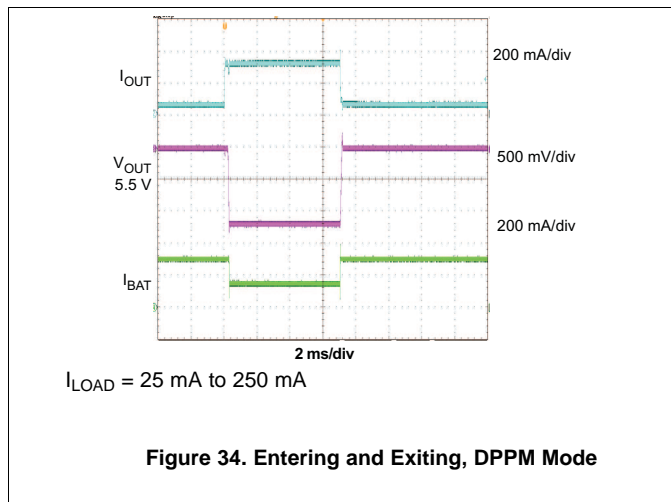

## 11 Power Supply Recommendations

### 11.1 Power On

When  $V_{IN}$  exceeds the UVLO threshold, the BQ2407xT powers up. While  $V_{IN}$  is below  $V_{BAT} + V_{IN(DT)}$ , the host commands at the control inputs ( $\overline{CE}$ , EN1 and EN2) are ignored. The Q1 FET connected between IN and OUT pins is off, and the status outputs CHG and PGOOD are high impedance. The Q2 FET that connects BAT to OUT is ON. (If SYSOFF is high, Q2 is off). During this mode, the  $V_{OUT(SC2)}$  circuitry is active and monitors for overload conditions on OUT.

Once  $V_{IN}$  rises above  $V_{BAT} + V_{IN(DT)}$ , PGOOD is driven low to indicate the valid power status and the  $\overline{CE}$ , EN1, and EN2 inputs are read. The device enters standby mode if (EN1 = EN2 = HI) or if an input overvoltage condition occurs. In standby mode, Q1 is OFF and Q2 is ON so OUT is connected to the battery input. (If SYSOFF is high, FET Q2 is off). During this mode, the  $V_{OUT(SC2)}$  circuitry is active and monitors for overload conditions on OUT.

When the input voltage at IN is within the valid range:  $V_{IN} > UVLO$  AND  $V_{IN} > V_{BAT} + V_{IN(DT)}$  AND  $V_{IN} < V_{OVP}$ , and the EN1 and EN2 pins indicate that the USB suspend mode is not enabled [(EN1, EN2) ≠ (HI, HI)] all internal timers and other circuit blocks are activated. The device then checks for short-circuits at the ISET and ILIM pins. If no short conditions exists, the device switches on the input FET Q1 with a 100mA current limit to checks for a short circuit at OUT. When  $V_{OUT}$  is above  $V_{SC}$ , the FET Q1 switches to the current limit threshold set by EN1, EN2 and  $R_{ILIM}$  and the device enters into the normal operation. During normal operation, the system is powered by the input source (Q1 is regulating), and the device continuously monitors the status of  $\overline{CE}$ , EN1 and EN2 as well as the input voltage conditions.

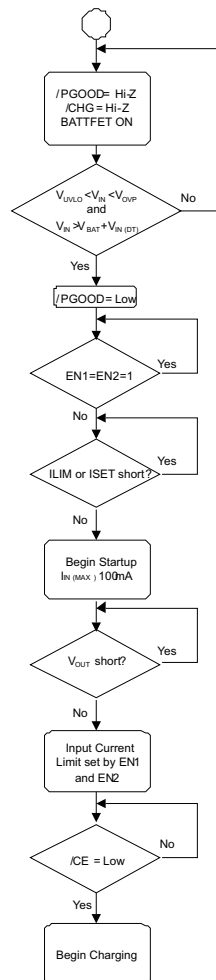

Figure 36. Startup Flow Diagram



## Power On (continued)

### 11.1.1 Half-Wave Adapters

Some adapters implement a half rectifier topology, which causes the adapter output voltage to fall below the battery voltage during part of the cycle. To enable operation with adapters under those conditions, the BQ2407xT family keeps the charger on for at least 20 msec (typical) after the input power puts the part in sleep mode. This feature enables use of external adapters using 50 Hz networks. The input must not drop below the UVLO voltage for the charger to work properly. Thus, the battery voltage should be above the UVLO to help prevent the input from dropping out. Additional input capacitance may be needed.

When the input is between  $V_{UVLO}$  and  $V_{IN(DT)}$ , the device enters sleep mode. After entering sleep mode for 20 ms the internal FET connection between the IN and OUT pin is disabled and pulling the input to ground will not discharge the battery, other than the leakage on the BAT pin. If one has a full 1000mAh battery and the leakage is 10  $\mu$ A, then it would take  $1000 \text{ mAh} / 10 \mu\text{A} = 100000$  hours (11.4 years) to discharge the battery. The battery's self discharge is typically 5 times higher than this.

## 12 Layout

### 12.1 Layout Guidelines

1. To obtain optimal performance, the decoupling capacitor from IN to GND (thermal pad) and the output filter capacitors from OUT to GND (thermal pad) should be placed as close as possible to the BQ2407xT, with short trace runs to both IN, OUT and GND (thermal pad).
2. All low-current GND connections should be kept separate from the high-current charge or discharge paths from the battery. Use a single-point ground technique incorporating both the small signal ground path and the power ground path.
3. The high current charge paths into IN pin and from the OUT pin must be sized appropriately for the maximum charge current in order to avoid voltage drops in these traces.

The BQ2407xT family is packaged in a thermally enhanced MLP package. The package includes a thermal pad to provide an effective thermal contact between the IC and the printed circuit board (PCB); this thermal pad is also the main ground connection for the device. Connect the thermal pad to the PCB ground connection. Full PCB design guidelines for this package are provided in [QFN and SON PCB Attachment Application Report](#).

### 12.2 Layout Example

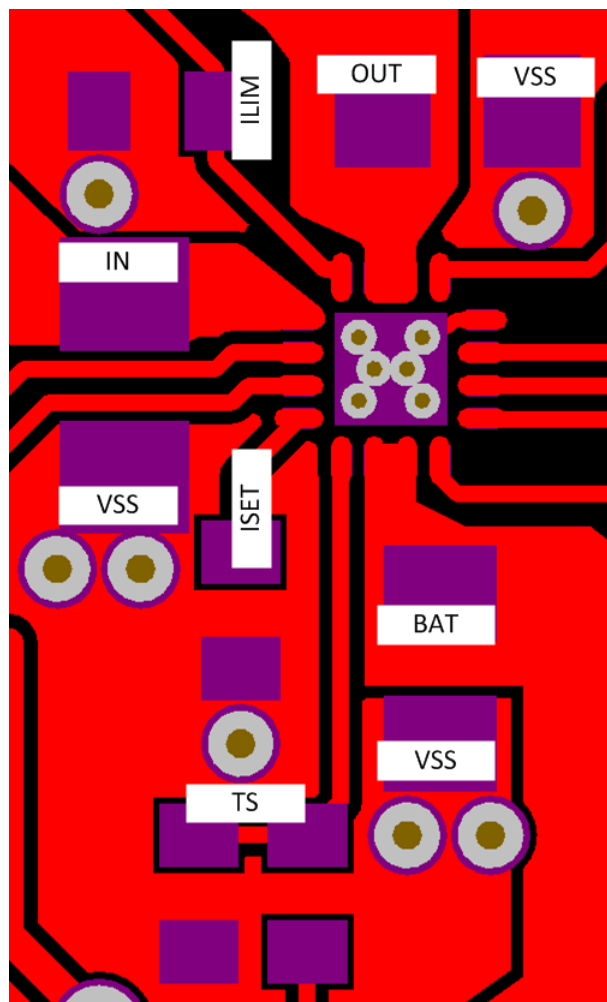

**Figure 37. BQ2407xT Layout**

### 12.3 Thermal Package

The BQ2407xT family is packaged in a thermally enhanced MLP package. The package includes a thermal pad to provide an effective thermal contact between the IC and the printed circuit board (PCB). The power pad should be directly connected to  $V_{SS}$ . Full PCB design guidelines for this package are provided in the application note entitled: QFN/SON PCB Attachment Application Note. The most common measure of package thermal performance is thermal impedance ( $\theta_{JA}$ ) measured (or modeled) from the chip junction to the air surrounding the package surface (ambient).

The mathematical expression for  $\theta_{JA}$  is:  $\theta_{JA} = (T_J - T) / P$

Where:

- $T_J$  = chip junction temperature
- $T$  = ambient temperature
- $P$  = device power dissipation
- Factors that can influence the measurement and calculation of  $\theta_{JA}$  include
- Whether or not the device is board mounted
- Trace size, composition, thickness, and geometry
- Orientation of the device (horizontal or vertical)
- Volume of the ambient air surrounding the device under test and airflow
- Whether other surfaces are in close proximity to the device being tested

Due to the charge profile of Li-Ion batteries the maximum power dissipation is typically seen at the beginning of the charge cycle when the battery voltage is at its lowest. Typically after fast charge begins the pack voltage increases to 3.4 V within the first 2 minutes. The thermal time constant of the assembly typically takes a few minutes to heat up so when doing maximum power dissipation calculations, 3.4 V is a good minimum voltage to use. This is verified, with the system and a fully discharged battery, by plotting temperature on the bottom of the PCB under the IC (pad should have multiple vias), the charge current and the battery voltage as a function of time. The fast charge current will start to taper off if the part goes into thermal regulation.

The device power dissipation,  $P$ , is a function of the charge rate and the voltage drop across the internal PowerFET. It can be calculated from [Equation 8](#) when a battery pack is being charged:

$$P = [V_{IN} - V_{OUT}] \times [I_{OUT} + I_{BAT}] + [V_{OUT} - V_{BAT}] \times I_{BAT} \quad (8)$$

The thermal loop feature reduces the charge current to limit excessive IC junction temperature. It is recommended that the design not run in thermal regulation for typical operating conditions (nominal input voltage and nominal ambient temperatures) and use the feature for non typical situations such as hot environments or higher than normal input source voltage. With that said, the IC still performs as described, if the thermal loop is always active.

## 13 デバイスおよびドキュメントのサポート

### 13.1 デバイス・サポート

#### 13.1.1 デベロッパー・ネットワークの製品に関する免責事項

デベロッパー・ネットワークの製品またはサービスに関するTIの出版物は、単独またはTIの製品、サービスと一緒に提供される場合に関係なく、デベロッパー・ネットワークの製品またはサービスの適合性に関する是認、デベロッパー・ネットワークの製品またはサービスの是認の表明を意味するものではありません。

### 13.2 関連リンク

次の表に、クイック・アクセス・リンクを示します。カテゴリには、技術資料、サポートおよびコミュニティ・リソース、ツールとソフトウェア、およびご注文へのクイック・アクセスが含まれます。

表 4. 関連リンク

製品	プロダクト・フォルダ	ご注文はこちら	技術資料	ツールとソフトウェア	サポートとコミュニティ
BQ24072T	<a href="#">ここをクリック</a>	<a href="#">ここをクリック</a>	<a href="#">ここをクリック</a>	<a href="#">ここをクリック</a>	<a href="#">ここをクリック</a>
BQ24075T	<a href="#">ここをクリック</a>	<a href="#">ここをクリック</a>	<a href="#">ここをクリック</a>	<a href="#">ここをクリック</a>	<a href="#">ここをクリック</a>
BQ24079T	<a href="#">ここをクリック</a>	<a href="#">ここをクリック</a>	<a href="#">ここをクリック</a>	<a href="#">ここをクリック</a>	<a href="#">ここをクリック</a>

### 13.3 ドキュメントの更新通知を受け取る方法

ドキュメントの更新についての通知を受け取るには、[ti.com](#) の本デバイスのプロダクト・フォルダを開いてください。右上の「アラートを受け取る」をクリックして登録すると、変更されたすべての製品情報に関するダイジェストを毎週受け取れます。変更の詳細については、修正されたドキュメントに含まれている改訂履歴をご覧ください。

### 13.4 サポート・リソース

TI E2E™ [support forums](#) are an engineer's go-to source for fast, verified answers and design help — straight from the experts. Search existing answers or ask your own question to get the quick design help you need.

Linked content is provided "AS IS" by the respective contributors. They do not constitute TI specifications and do not necessarily reflect TI's views; see TI's [Terms of Use](#).

### 13.5 商標

E2E is a trademark of Texas Instruments.  
All other trademarks are the property of their respective owners.

### 13.6 静電気放電に関する注意事項



これらのデバイスは、限定的なESD(静電破壊)保護機能を内蔵しています。保存時または取り扱い時は、MOSゲートに対する静電破壊を防止するために、リード線同士をショートさせておくか、デバイスを導電フォームに入れる必要があります。

### 13.7 Glossary

[SLYZ022](#) — TI Glossary.

This glossary lists and explains terms, acronyms, and definitions.

## 14 メカニカル、パッケージ、および注文情報

以降のページには、メカニカル、パッケージ、および注文に関する情報が記載されています。この情報は、そのデバイスについて利用可能な最新のデータです。このデータは予告なく変更されることがあり、ドキュメントが改訂される場合もあります。本データシートのブラウザ版を使用されている場合は、画面左側の説明をご覧ください。

**PACKAGING INFORMATION**

Orderable part number	Status (1)	Material type (2)	Package   Pins	Package qty   Carrier	RoHS (3)	Lead finish/ Ball material (4)	MSL rating/ Peak reflow (5)	Op temp (°C)	Part marking (6)
<a href="#">BQ24072TRGTR</a>	Active	Production	VQFN (RGT)   16	3000   LARGE T&R	Yes	NIPDAU	Level-2-260C-1 YEAR	-40 to 85	PAP
BQ24072TRGTR.A	Active	Production	VQFN (RGT)   16	3000   LARGE T&R	Yes	NIPDAU	Level-2-260C-1 YEAR	-40 to 85	PAP
BQ24072TRGTR.B	Active	Production	VQFN (RGT)   16	3000   LARGE T&R	Yes	NIPDAU	Level-2-260C-1 YEAR	-40 to 85	PAP
<a href="#">BQ24072TRGTT</a>	Active	Production	VQFN (RGT)   16	250   SMALL T&R	Yes	NIPDAU	Level-2-260C-1 YEAR	-40 to 85	PAP
BQ24072TRGTT.A	Active	Production	VQFN (RGT)   16	250   SMALL T&R	Yes	NIPDAU	Level-2-260C-1 YEAR	-40 to 85	PAP
BQ24072TRGTT.B	Active	Production	VQFN (RGT)   16	250   SMALL T&R	Yes	NIPDAU	Level-2-260C-1 YEAR	-40 to 85	PAP
<a href="#">BQ24075TRGTR</a>	Active	Production	VQFN (RGT)   16	3000   LARGE T&R	Yes	NIPDAU	Level-2-260C-1 YEAR	-40 to 85	OEC
BQ24075TRGTR.A	Active	Production	VQFN (RGT)   16	3000   LARGE T&R	Yes	NIPDAU	Level-2-260C-1 YEAR	-40 to 85	OEC
BQ24075TRGTR.B	Active	Production	VQFN (RGT)   16	3000   LARGE T&R	Yes	NIPDAU	Level-2-260C-1 YEAR	-40 to 85	OEC
<a href="#">BQ24075TRGTT</a>	Active	Production	VQFN (RGT)   16	250   SMALL T&R	Yes	NIPDAU	Level-2-260C-1 YEAR	-40 to 85	OEC
BQ24075TRGTT.A	Active	Production	VQFN (RGT)   16	250   SMALL T&R	Yes	NIPDAU	Level-2-260C-1 YEAR	-40 to 85	OEC
BQ24075TRGTT.B	Active	Production	VQFN (RGT)   16	250   SMALL T&R	Yes	NIPDAU	Level-2-260C-1 YEAR	-40 to 85	OEC
<a href="#">BQ24079TRGTR</a>	Active	Production	VQFN (RGT)   16	3000   LARGE T&R	Yes	NIPDAU	Level-2-260C-1 YEAR	-40 to 85	OED
BQ24079TRGTR.A	Active	Production	VQFN (RGT)   16	3000   LARGE T&R	Yes	NIPDAU	Level-2-260C-1 YEAR	-40 to 85	OED
BQ24079TRGTR.B	Active	Production	VQFN (RGT)   16	3000   LARGE T&R	Yes	NIPDAU	Level-2-260C-1 YEAR	-40 to 85	OED
<a href="#">BQ24079TRGTT</a>	Active	Production	VQFN (RGT)   16	250   SMALL T&R	Yes	NIPDAU	Level-2-260C-1 YEAR	-40 to 85	OED
BQ24079TRGTT.A	Active	Production	VQFN (RGT)   16	250   SMALL T&R	Yes	NIPDAU	Level-2-260C-1 YEAR	-40 to 85	OED
BQ24079TRGTT.B	Active	Production	VQFN (RGT)   16	250   SMALL T&R	Yes	NIPDAU	Level-2-260C-1 YEAR	-40 to 85	OED

(1) **Status:** For more details on status, see our [product life cycle](#).

(2) **Material type:** When designated, preproduction parts are prototypes/experimental devices, and are not yet approved or released for full production. Testing and final process, including without limitation quality assurance, reliability performance testing, and/or process qualification, may not yet be complete, and this item is subject to further changes or possible discontinuation. If available for ordering, purchases will be subject to an additional waiver at checkout, and are intended for early internal evaluation purposes only. These items are sold without warranties of any kind.

(3) **RoHS values:** Yes, No, RoHS Exempt. See the [TI RoHS Statement](#) for additional information and value definition.

(4) **Lead finish/Ball material:** Parts may have multiple material finish options. Finish options are separated by a vertical ruled line. Lead finish/Ball material values may wrap to two lines if the finish value exceeds the maximum column width.

(5) **MSL rating/Peak reflow:** The moisture sensitivity level ratings and peak solder (reflow) temperatures. In the event that a part has multiple moisture sensitivity ratings, only the lowest level per JEDEC standards is shown. Refer to the shipping label for the actual reflow temperature that will be used to mount the part to the printed circuit board.

(6) **Part marking:** There may be an additional marking, which relates to the logo, the lot trace code information, or the environmental category of the part.

Multiple part markings will be inside parentheses. Only one part marking contained in parentheses and separated by a "~" will appear on a part. If a line is indented then it is a continuation of the previous line and the two combined represent the entire part marking for that device.

**Important Information and Disclaimer:**The information provided on this page represents TI's knowledge and belief as of the date that it is provided. TI bases its knowledge and belief on information provided by third parties, and makes no representation or warranty as to the accuracy of such information. Efforts are underway to better integrate information from third parties. TI has taken and continues to take reasonable steps to provide representative and accurate information but may not have conducted destructive testing or chemical analysis on incoming materials and chemicals. TI and TI suppliers consider certain information to be proprietary, and thus CAS numbers and other limited information may not be available for release.

In no event shall TI's liability arising out of such information exceed the total purchase price of the TI part(s) at issue in this document sold by TI to Customer on an annual basis.

**TAPE AND REEL INFORMATION**

**QUADRANT ASSIGNMENTS FOR PIN 1 ORIENTATION IN TAPE**

\*All dimensions are nominal

Device	Package Type	Package Drawing	Pins	SPQ	Reel Diameter (mm)	Reel Width W1 (mm)	A0 (mm)	B0 (mm)	K0 (mm)	P1 (mm)	W (mm)	Pin1 Quadrant
BQ24072TRGTR	VQFN	RGT	16	3000	330.0	12.4	3.3	3.3	1.1	8.0	12.0	Q2
BQ24072TRGTT	VQFN	RGT	16	250	180.0	12.4	3.3	3.3	1.1	8.0	12.0	Q2
BQ24075TRGTR	VQFN	RGT	16	3000	330.0	12.4	3.3	3.3	1.1	8.0	12.0	Q2
BQ24075TRGTT	VQFN	RGT	16	250	180.0	12.4	3.3	3.3	1.1	8.0	12.0	Q2
BQ24079TRGTR	VQFN	RGT	16	3000	330.0	12.4	3.3	3.3	1.1	8.0	12.0	Q2
BQ24079TRGTR	VQFN	RGT	16	3000	330.0	12.4	3.3	3.3	1.1	8.0	12.0	Q2
BQ24079TRGTT	VQFN	RGT	16	250	180.0	12.4	3.3	3.3	1.1	8.0	12.0	Q2
BQ24079TRGTT	VQFN	RGT	16	250	180.0	12.4	3.3	3.3	1.1	8.0	12.0	Q2

**TAPE AND REEL BOX DIMENSIONS**

\*All dimensions are nominal

Device	Package Type	Package Drawing	Pins	SPQ	Length (mm)	Width (mm)	Height (mm)
BQ24072TRGTR	VQFN	RGT	16	3000	346.0	346.0	33.0
BQ24072TRGTT	VQFN	RGT	16	250	210.0	185.0	35.0
BQ24075TRGTR	VQFN	RGT	16	3000	346.0	346.0	33.0
BQ24075TRGTT	VQFN	RGT	16	250	210.0	185.0	35.0
BQ24079TRGTR	VQFN	RGT	16	3000	367.0	367.0	35.0
BQ24079TRGTR	VQFN	RGT	16	3000	346.0	346.0	33.0
BQ24079TRGTT	VQFN	RGT	16	250	210.0	185.0	35.0
BQ24079TRGTT	VQFN	RGT	16	250	210.0	185.0	35.0



**RGT 16**

**GENERIC PACKAGE VIEW**

**VQFN - 1 mm max height**

PLASTIC QUAD FLATPACK - NO LEAD



Images above are just a representation of the package family, actual package may vary.  
Refer to the product data sheet for package details.

4203495/1

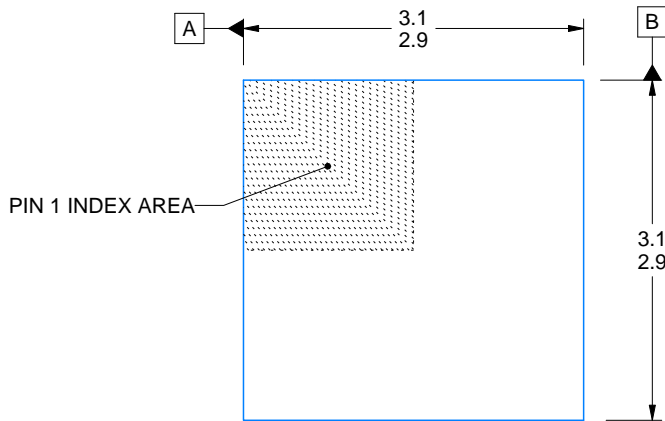
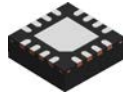

SIDE WALL METAL THICKNESS DIM A	
OPTION 1	OPTION 2
0.1	0.2

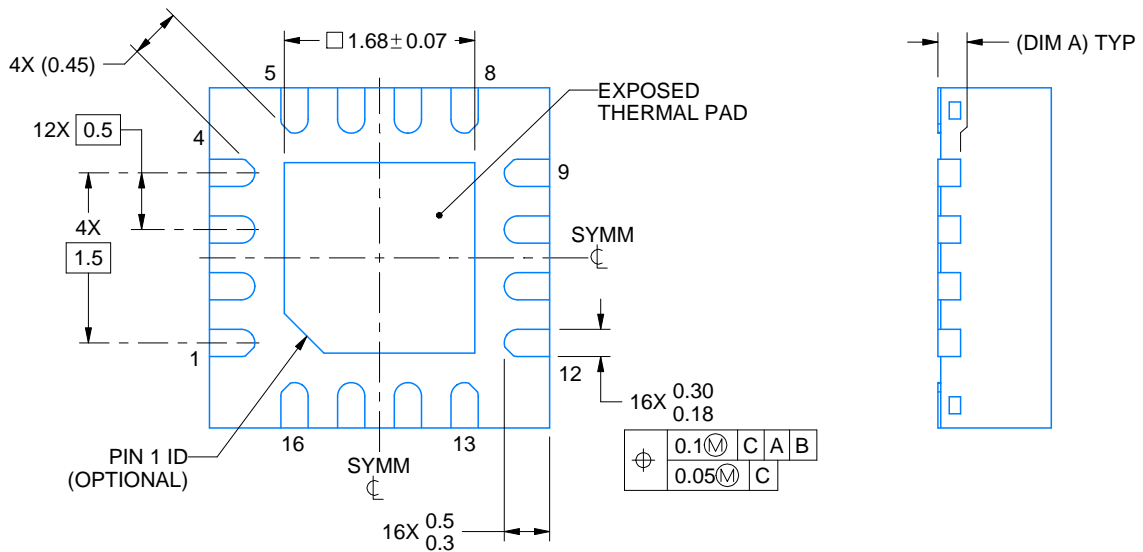
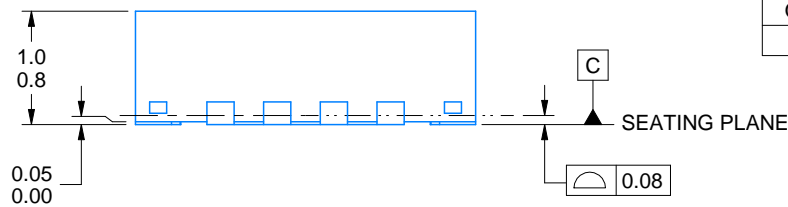

4222419/E 07/2025

NOTES:

1. All linear dimensions are in millimeters. Any dimensions in parenthesis are for reference only. Dimensioning and tolerancing per ASME Y14.5M.
2. This drawing is subject to change without notice.
3. The package thermal pad must be soldered to the printed circuit board for thermal and mechanical performance.

# EXAMPLE BOARD LAYOUT

RGT0016C

VQFN - 1 mm max height

PLASTIC QUAD FLATPACK - NO LEAD

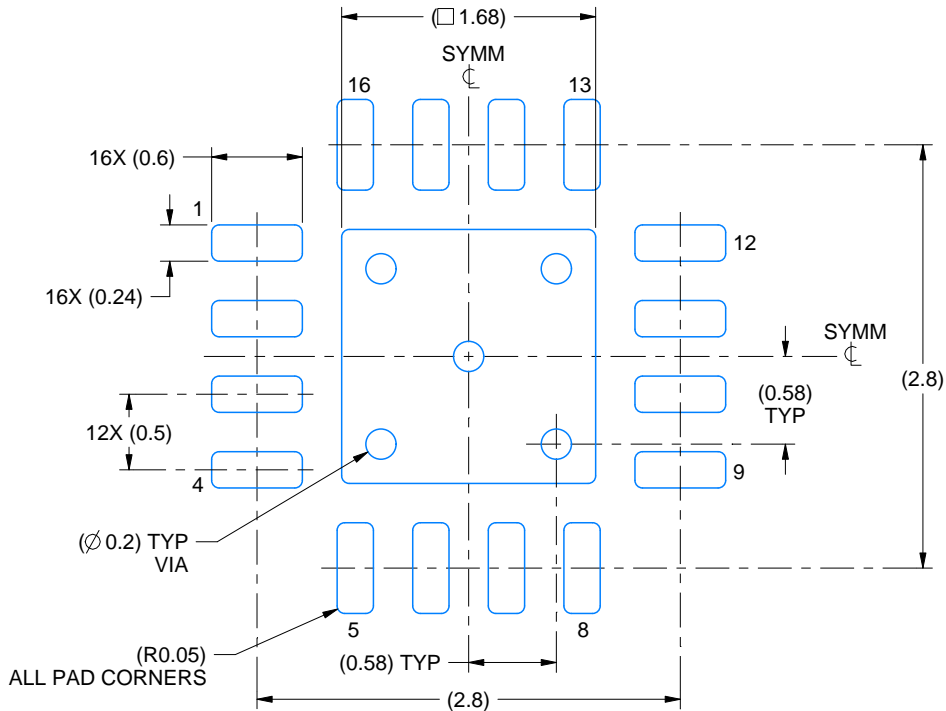

LAND PATTERN EXAMPLE  
EXPOSED METAL SHOWN  
SCALE:20X

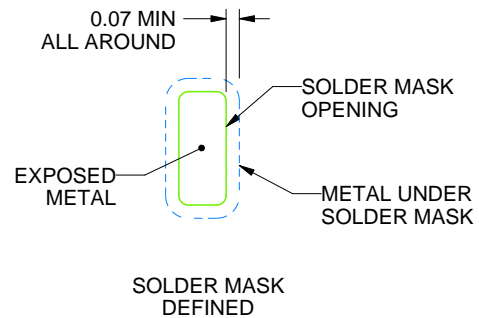
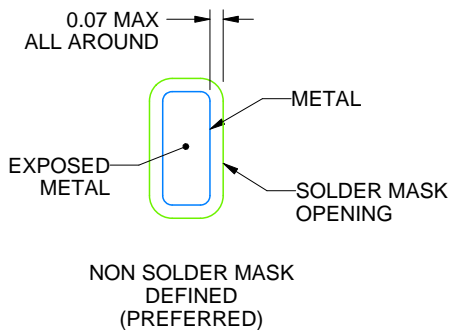

SOLDER MASK DETAILS

4222419/E 07/2025

NOTES: (continued)

- 4. This package is designed to be soldered to a thermal pad on the board. For more information, see Texas Instruments literature number SLUA271 ([www.ti.com/lit/slua271](http://www.ti.com/lit/slua271)).
- 5. Vias are optional depending on application, refer to device data sheet. If any vias are implemented, refer to their locations shown on this view. It is recommended that vias under paste be filled, plugged or tented.

# EXAMPLE STENCIL DESIGN

RGT0016C

VQFN - 1 mm max height

PLASTIC QUAD FLATPACK - NO LEAD

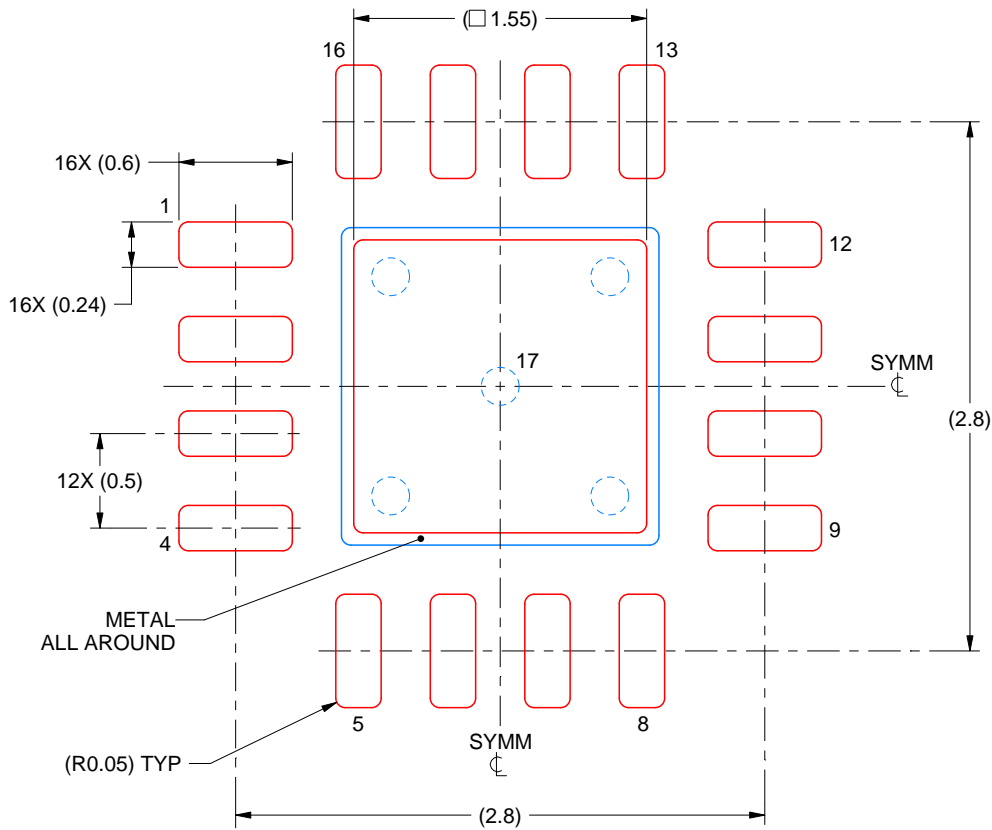

**SOLDER PASTE EXAMPLE**  
BASED ON 0.125 mm THICK STENCIL

EXPOSED PAD 17:  
85% PRINTED SOLDER COVERAGE BY AREA UNDER PACKAGE  
SCALE:25X

4222419/E 07/2025

NOTES: (continued)

6. Laser cutting apertures with trapezoidal walls and rounded corners may offer better paste release. IPC-7525 may have alternate design recommendations.

## 重要なお知らせと免責事項

TI は、技術データと信頼性データ(データシートを含みます)、設計リソース(リファレンス デザインを含みます)、アプリケーションや設計に関する各種アドバイス、Web ツール、安全性情報、その他のリソースを、欠陥が存在する可能性のある「現状のまま」提供しており、商品性および特定目的に対する適合性の黙示保証、第三者の知的財産権の非侵害保証を含むいかなる保証も、明示的または黙示的にかかわらず拒否します。

これらのリソースは、TI 製品を使用する設計の経験を積んだ開発者への提供を意図したものです。(1) お客様のアプリケーションに適した TI 製品の選定、(2) お客様のアプリケーションの設計、検証、試験、(3) お客様のアプリケーションに該当する各種規格や、その他のあらゆる安全性、セキュリティ、規制、または他の要件への確実な適合に関する責任を、お客様のみが単独で負うものとし、

上記の各種リソースは、予告なく変更される可能性があります。これらのリソースは、リソースで説明されている TI 製品を使用するアプリケーションの開発の目的でのみ、TI はその使用をお客様に許諾します。これらのリソースに関して、他の目的で複製することや掲載することは禁止されています。TI や第三者の知的財産権のライセンスが付与されている訳ではありません。お客様は、これらのリソースを自身で使用した結果発生するあらゆる申し立て、損害、費用、損失、責任について、TI およびその代理人を完全に補償するものとし、TI は一切の責任を拒否します。

TI の製品は、[TI の販売条件](#)、[TI の総合的な品質ガイドライン](#)、[ti.com](#) または TI 製品などに関連して提供される他の適用条件に従い提供されます。TI がこれらのリソースを提供することは、適用される TI の保証または他の保証の放棄の拡大や変更を意味するものではありません。TI がカスタム、またはカスタマー仕様として明示的に指定していない限り、TI の製品は標準的なカタログに掲載される汎用機器です。

お客様がいかなる追加条項または代替条項を提案する場合も、TI はそれらに異議を唱え、拒否します。

Copyright © 2025, Texas Instruments Incorporated

最終更新日：2025 年 10 月