

## TI Designs: TIDA-01539

# 适用于电致变色视镜的汽车自动调光镜参考设计



### 说明

现代汽车利用自动调光镜来防止炫光和可见度损失对驾驶员造成的影响。此参考设计利用现代人眼光学反应环境光传感器以及一个高电流放大器功率级来驱动电容式电致变色镜负载。

### 资源

<a href="#">TIDA-01539</a>	设计文件夹
<a href="#">OPT3001-Q1</a>	产品文件夹
<a href="#">DAC101C081Q</a>	产品文件夹
<a href="#">TLV316-Q1</a>	产品文件夹
<a href="#">TPS7B69-Q1</a>	产品文件夹

### 特性

- 人眼响应光传感器
- 10 位输出
- 3.3V、400mA 电容负载驱动器
- 电致变色负载快速放电
- 宽 VBAT 运行 (高达 40V)
- 专为 Licon 电致变色视镜而设计

### 应用

- 后视镜
- 侧后视镜



咨询我们的 E2E™ 专家

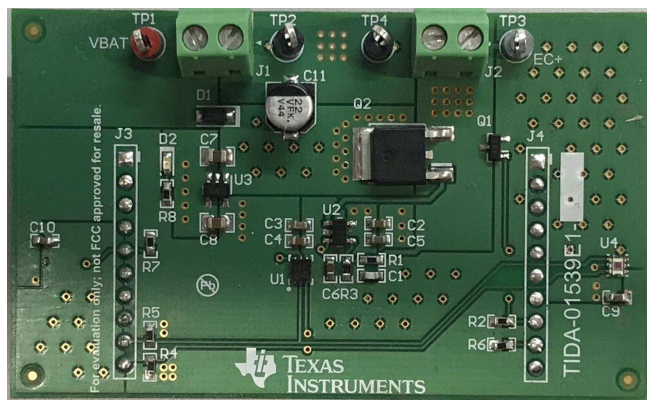
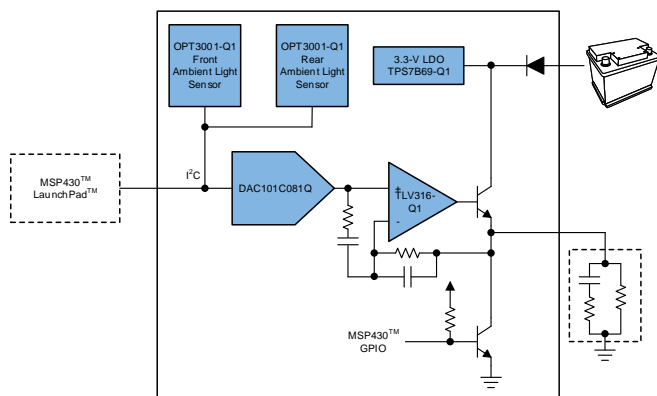

该 TI 参考设计末尾的重要声明表述了授权使用、知识产权问题和其他重要的免责声明和信息。

## 1 System Description

Auto-dimming mirrors allow for active adjustment of rear and side mirrors to reduce glare generated by bright sources of light outside of a vehicle. Electrochromic smart glass uses electrical stimulation to darken and lower reflections of light. The combination of accurate ambient light sensors, a precise digital-to-analog converter (DAC), and an operational amplifier (op amp) driver stage creates a smart auto-dimming mirror solution.

### 1.1 Key System Specifications

表 1. Key System Specifications

PARAMETER	SPECIFICATIONS	DETAILS
Input voltage range	4 V to 40 V	<a href="#">节 2.3.4</a>
Output driver range	0 V to 3.3 V	<a href="#">节 2.3.3</a>
Output current	500 mA	<a href="#">节 2.3.3</a>
Output resolution	10 bit	<a href="#">节 2.3.2</a>
Maximum full-scale light capture range	83865.60 lux	<a href="#">节 2.3.1</a>

## 2 System Overview

### 2.1 Block Diagram



图 1. TIDA-01359 Block Diagram

### 2.2 Highlighted Products

#### 2.2.1 OPT3001-Q1

The OPT3001-Q1 device is an optical sensor that measures the intensity of visible light. The spectral response of the sensor tightly matches the photooptic response of the human eye and includes significant infrared (IR) rejection.

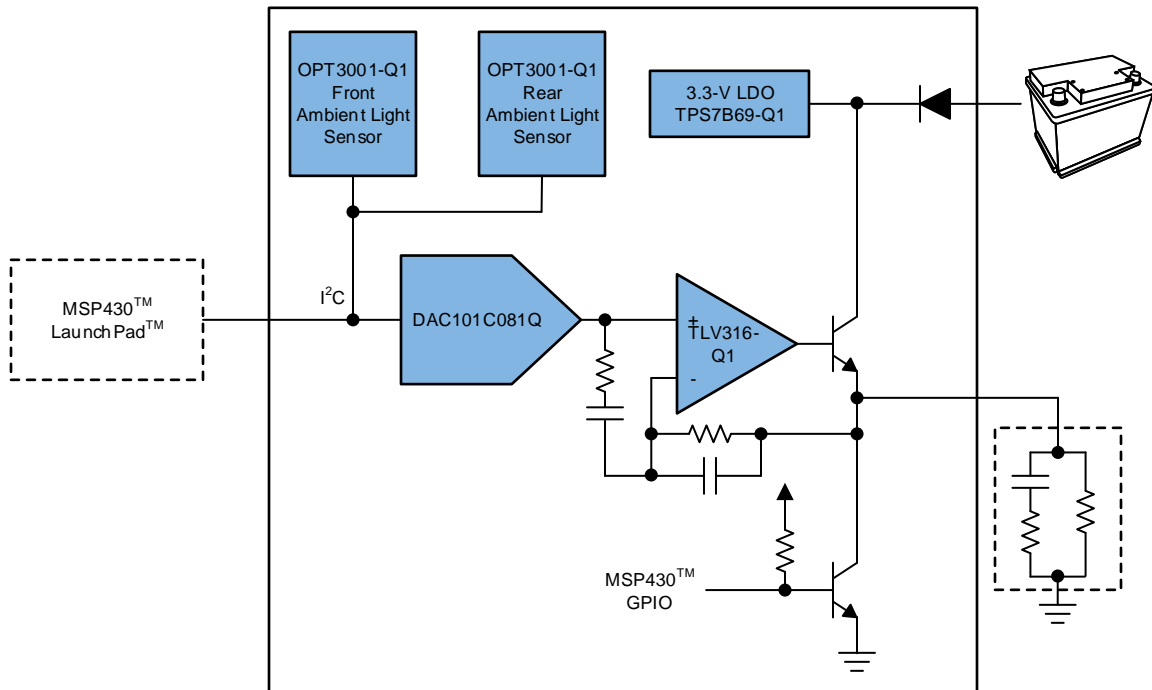
The OPT3001-Q1 device is a single-chip lux meter, measuring the intensity of light as visible by the human eye. The precision spectral response and strong IR rejection of the device enables the OPT3001-Q1 device to accurately meter the intensity of light as seen by the human eye, regardless of light source. The strong IR rejection also helps maintain high accuracy when an industrial design requires mounting the sensor under dark glass for aesthetics. The OPT3001-Q1 device is designed for systems that create light-based experiences for humans, and an ideal preferred replacement for photodiodes, photoresistors, or other ambient light sensors with less human eye matching and IR rejection.

图 2 shows the OPT3001-Q1 block diagram and 图 3 shows the OPT3001-Q1 spectral response.



图 2. OPT3001-Q1 Block Diagram



图 3. OPT3001-Q1 Spectral Response

### 2.2.2 DAC101C081Q

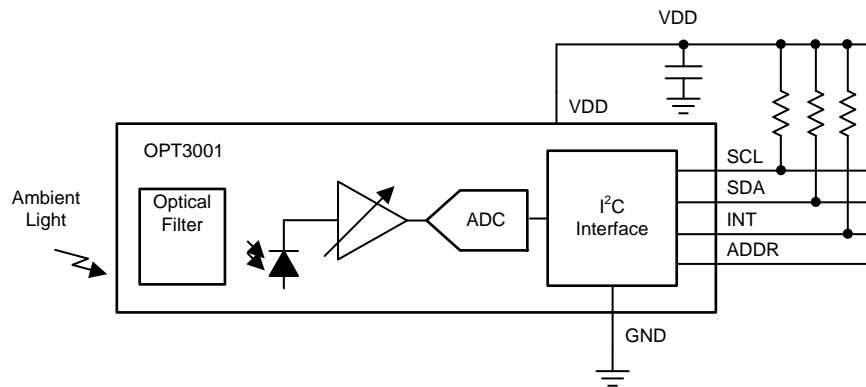
The DAC101C081Q device is a 10-bit, single channel, voltage-output digital-to-analog converter (DAC) that operates from a 2.7-V to 5.5-V supply. The output amplifier allows rail-to-rail output swing and has a 6- $\mu$ sec settling time. The DAC101C081 uses the supply voltage as the reference to provide the widest dynamic output range and typically consumes 132  $\mu$ A while operating at 5.0 V. The DAC101C081Q is available in 6-lead SOT and WSON packages and provides three address options (pin selectable).

图 4 shows the DAC101C081Q block diagram.

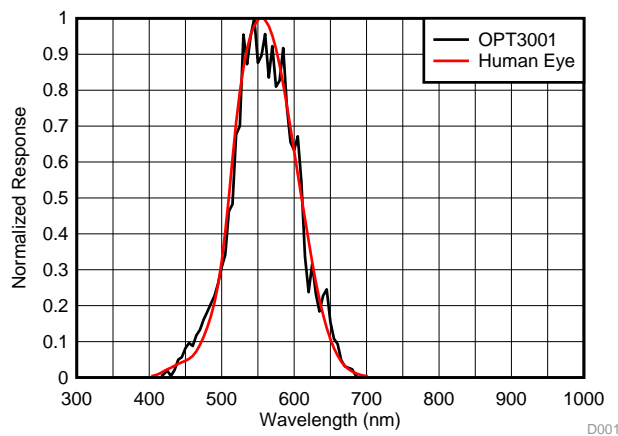

图 4. DAC101C081Q Block Diagram

### 2.2.3 TLV316-Q1

The TLV316 is a general-purpose, low-power op amp. Features such as rail-to-rail input and output swings, low quiescent current (400  $\mu\text{A}/\text{ch}$  typical) combined with a wide bandwidth of 10 MHz, and very-low noise (12  $\text{nV}/\sqrt{\text{Hz}}$  at 1 kHz) make the device attractive for a variety of applications that require a good balance between cost and performance. The low input bias current supports op amps that are used in applications with  $\text{M}\Omega$  source impedances.

The robust design of the TLV316 provides ease-of-use to the circuit designer through a unity-gain stable, integrated radio frequency interference (RFI) and electromagnetic interference (EMI) rejection filter, no phase reversal in overdrive condition, and high electrostatic discharge (ESD) protection (4-kV human body model (HBM)).

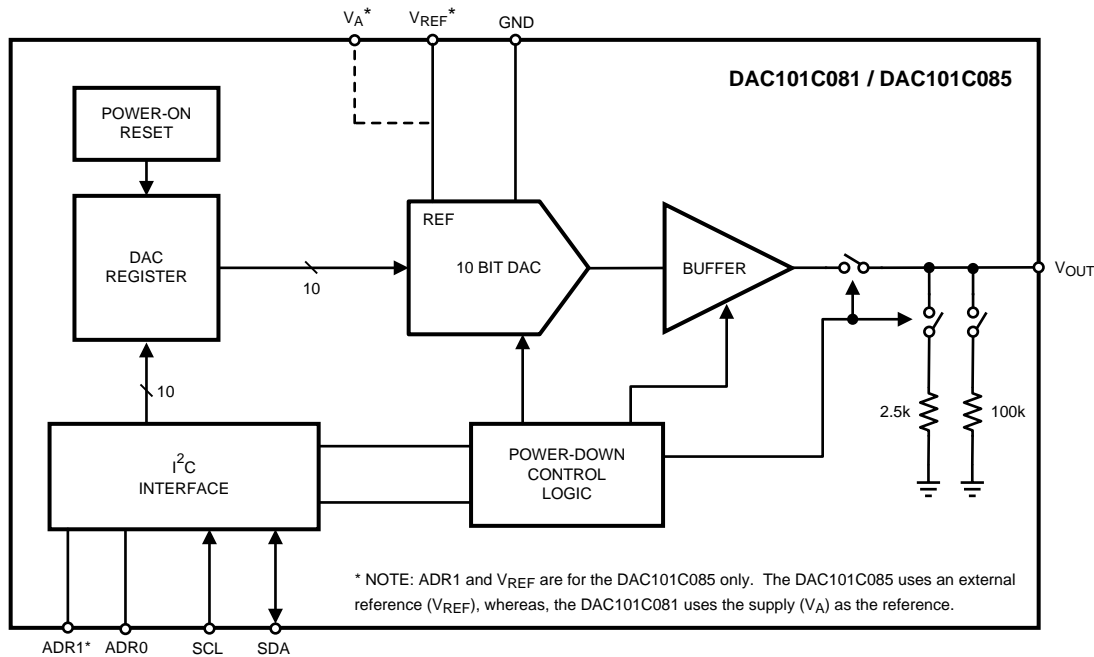
图 5 shows the TLV316-Q1 block diagram.



图 5. TLV316-Q1 Block Diagram

#### 2.2.4 TPS7B69-Q1

The TPS7B69-Q1 device is a low-dropout linear regulator designed for up to 40-V VI operations. With only 15- $\mu$ A (typical) quiescent current at light load, the device is suitable for standby microcontrol-unit systems, especially in automotive applications. The device also features integrated short-circuit and overcurrent protection.

The TPS7B69-Q1 device operates over a  $-40^{\circ}\text{C}$  to  $125^{\circ}\text{C}$  temperature range. Because of these features, the TPS7B69-Q1 is well suited in power supplies for various automotive applications.

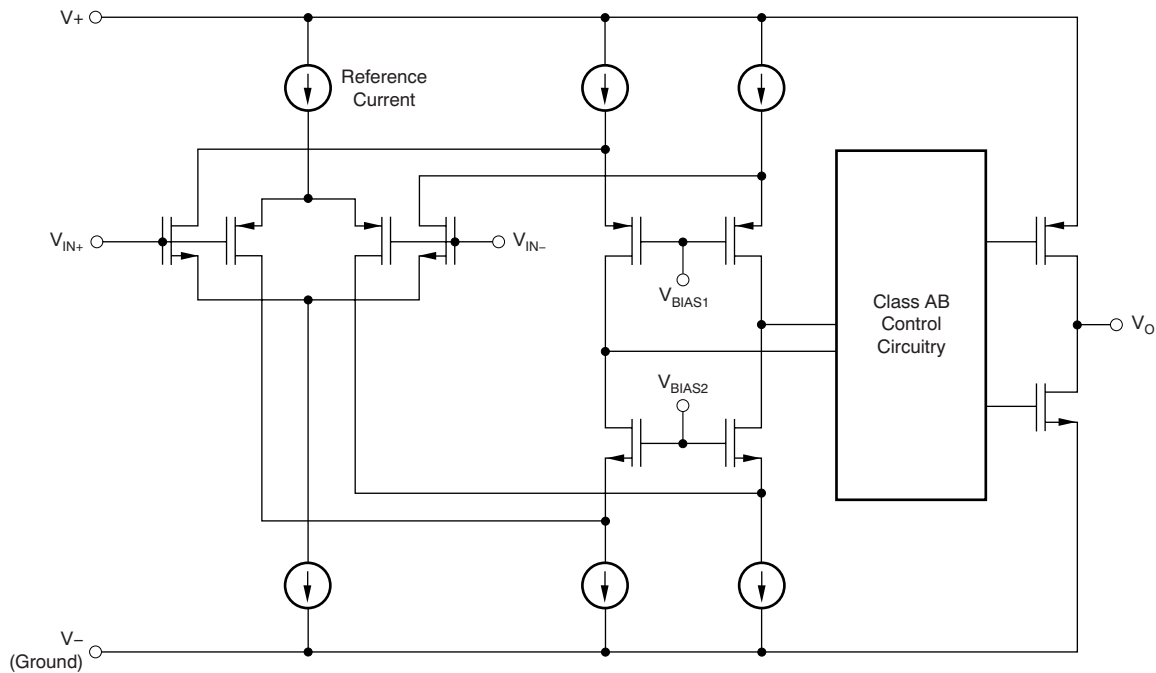
In this design, the TPS7B6933-Q1 was used for its 3.3V output configuration to power an MSP430 microcontroller and the OPT3001-Q1 light sensors.

### 2.3 System Design Theory

#### 2.3.1 Ambient Light Sensors

This reference design uses two ambient light sensors. One sensor acts as a reference for the amount of general ambient light present outside of the vehicle. This typical location for this sensor is facing out of the back of the mirror module toward the front of the vehicle. The purpose of the other sensor is to capture the light intensity of potential obstructions coming from the rear of the car. This sensor faces toward the back of the vehicle.

The OPT3001 ambient light sensor is very simple to design around by following the standard guidelines provided in the data sheet. A localized 100-nF decoupling capacitor for the 3.3-V supply is the only external component necessary. To set individual addresses for both light sensors, the ADDR pin on one device is tied to VDD and the other is tied to ground. lists the I<sup>2</sup>C addresses.

表 2. OPT3001 I<sup>2</sup>C Address Configuration

OPT3001 SCHEMATIC INDICATOR	ADDR NET	I <sup>2</sup> C ADDRESS
U4	GND	1000100b, 44h
U5	VDD	1000101b, 45h

The I<sup>2</sup>C lines, SCL and SDA, are shared between these devices and the DAC101C081. Use an off-board I<sup>2</sup>C master, such as the MSP430™ MCU LaunchPad™ Development Kit, to control I<sup>2</sup>C. The INT pins of the device are tied individually to a general-purpose input/output (GPIO) pin. All of these pins are pulled up to 3.3 V with 10-kΩ resistors.

Additional guidance related to optics and proper packaging of the light sensors for ideal light capture depend on the application. Find more details in [OPT3001: Ambient Light Sensor Application Guide](#)

### 2.3.1.1 Configuration of OPT3001

For this design, the ambient light sensors are configured into different modes over I<sup>2</sup>C.

#### 2.3.1.1.1 Latched Window-Style Comparison Mode

The device which captures the general ambient light around the car uses a mode called latched window-style comparison. This mode is an interrupt reporting mechanism which allows the device to recognize a fault event whenever a user-configured light intensity is reached. The INT pin of the OPT3001 triggers high or low based on a set hysteresis-style limit window. The toggling of this pin then indicates whether or not the MCU must capture the light intensity of the other OPT3001 sensor and drive the electrochromic (EC) mirror appropriately. Register addresses 0x02 and 0x03 control the low and high limit, respectively, and the designer must configure these appropriately for the application.

#### 2.3.1.2 Lux-Scaled Range Mode

The other OPT3001 sensor is responsible for capturing the light intensity of possible light obstructions reflected by the mirror. The designer can configure this sensor to capture a specific range of light and scale the digital output appropriately. The lux captured by the OPT3001 can be read from the result register (0x01) as a 16 bit value. The 4 most significant bits (MSB), bits 15 through 12, set the scaling of output in lux per least significant bit (LSB), and are known as the “LSB\_Size” exponent bits. The other 12 bits (bits 11 to 0) are a linear fractional result from 0 lux to the full scale set by LSB\_Size. 表 3 和 表 4 list the full-scale range and LSB\_Size values.

表 3. OPT3001 Result Register Field Descriptions

BIT	FIELD	TYPE	RESET	DESCRIPTION
15:12	E[3:0]	R	0h	<b>Exponent.</b> These bits are the exponent bits. 表 4 provides further details.
11:0	R[11:0]	R	000h	<b>Fractional result.</b> These bits are the result in straight binary coding (zero to full-scale).

表 4. OPT3001 Full-Scale Range and LSB Size as Function of Exponent Level

E3	E2	E1	E0	FULL-SCALE RANGE (lux)	LSB SIZE (lux per LSB)
0	0	0	0	40.95	0.01
0	0	0	1	81.90	0.02
0	0	1	0	163.80	0.04
0	0	1	1	327.60	0.08
0	1	0	0	655.20	0.16

表 4. OPT3001 Full-Scale Range and LSB Size as Function of Exponent Level (continued)

E3	E2	E1	E0	FULL-SCALE RANGE (lux)	LSB SIZE (lux per LSB)
0	1	0	1	1310.40	0.32
0	1	1	0	2620.80	0.64
0	1	1	1	5241.60	1.28
1	0	0	0	10483.20	2.56
1	0	0	1	20966.40	5.12
1	0	1	0	41932.80	10.24
1	0	1	1	83865.60	20.48

Use to translate the binary value to the appropriate lux value:

$$\text{lux} = \text{LSB\_Size} \times R[11:0] \tag{1}$$

where,

- $\text{LSB\_Size} = 0.01 \times 2^{E[3:0]}$ .

The configuration register 0x01 allows the designer to specify the LSB\_Size to set the maximum lux value for capture by the OPT3001 sensor. Make this setting based on the application-specific requirements of the design. The MCU can then perform any translation of the 16-bit OPT3001 data and then generate a 10-bit value to send to the DAC101C081 device.

图 6 shows the schematic for the ambient light sensors.



图 6. Ambient Light Sensors Schematic



### 2.3.2 DAC

The DAC101C081 is an I<sup>2</sup>C-controlled DAC that requires minimal external components for normal functionality. This device uses the VA pin as both the device supply voltage as well as the reference voltage for the DAC. The user must implement two local decoupling capacitors (4.7  $\mu$ F and 100 nF) to ensure typical operation.

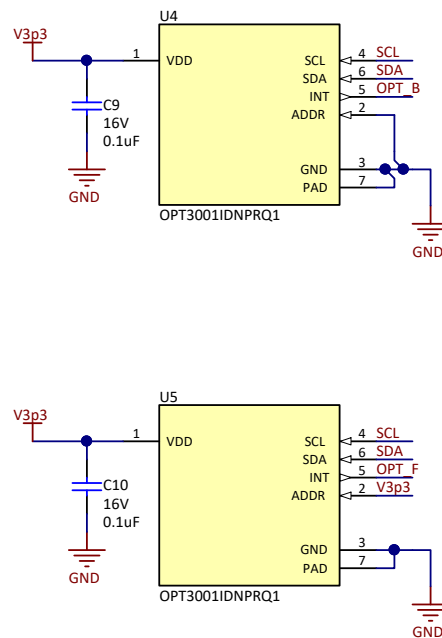
To configure the DAC101C081 address, the ADR0 pin is tied to the supply voltage, which represents a device address of 0x0E.

A 10-bit value can be written to the DAC, generating a 0-V to 3.3-V output to drive the output buffer amplifier stage. While dependent on the EC mirror, the typical maximum output required to drive the mirror is approximately 2 V, or a DAC code of 0x26C.

图 7 shows the DAC schematic.



图 7. DAC Schematic

### 2.3.3 Electrochromic Mirror Driver

The electrochromic (EC) mirror utilizes a proprietary electrochromic chemical placed between two conductive layers and glass panels. When a voltage is applied to these conductive elements, the current flow through the chemical causes it to change in color and darken. Electrically, the electrochromic mirror behaves like a very large capacitor, typically greater than 1 F, as well as a small shunt resistance. The total capacitance measured largely depends on the total area of the mirror.

#### 2.3.3.1 High-Current Buffer Amplifier

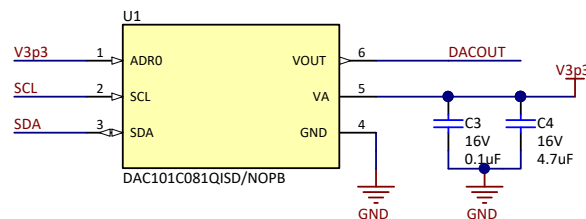
To drive this mirror, the voltage output necessary is less than 2 V for the maximum amount of dimming. Due to the size of this capacitive load, the current necessary to charge it can reach as much as 400 mA. A steady state of approximately 150 mA is also required to maintain proper dimming. To meet these specifications, use an op amp and Darlington bipolar junction transistor BJT to buffer from the output of the DAC101C081 and drive the electrochromic load. The BJT sources the current for the load and the use of an op amp feedback provides stability and linearity regardless of the temperature or process variation of the BJT.

The MJD122 Darlington-pair BJT is chosen for its large 100-V collector-emitter voltage to allow use across both the typical and non-typical automotive battery operating voltage range, as well as the very-large, 8-A continuous current operation. The DPAK package is great for dissipating heat generated by the typical 2 W of power flowing through the device.

### 2.3.3.2 Buffer Amplifier Stability for Very-Large Capacitive Loads

Due to the size of the capacitive load, stability of the buffer amplifier is a concern. Designers can improve capacitive load stability through the use of both noise gain and capacitive feedback compensation.

Using rate of closure analysis provides a guideline on the expected phase margin on an amplifier based on the angle of the slopes between the modified open loop gain and  $1/\beta$  bode plots. A key rule is to ensure the rate of closure is not greater than 20 dB/decade, which ensures the phase margin of the design is greater than  $45^\circ$ . For more information on op amps and stability, see the training resource [TI Precision Labs - Ops Amps: Stability 2](#).

The noise gain compensation consists of implementing high-frequency gain to allow the  $1/\beta$  of the amplifier to be larger than the modified open-loop gain at the pole introduced by the capacitive load, which allows the rate of the closure to be 20 dB/decade rather than 40 dB/decade. This method retains the desired 0-dB gain at DC that allows the amplifier to continue to operate as a buffer. The noise gain provides the necessary bump in the phase margin to maintain stability across the entire bandwidth of the amplifier and prevent ringing.

This high-frequency gain is implemented with R1, R3, and C6, which creates a zero and provides a 20-dB/decade slope on the  $1/\beta$  plot above approximately 1 kHz. The rate of closure at the intersection is then  $|-40 \text{ dB/decade} + 20 \text{ dB/decade}| = 20 \text{ dB/decade}$ .

To add to the stability improvements found with noise gain, an additional capacitor C1 is used to implement a capacitive feedback, or  $C_f$ , compensation. This additional high-frequency pole boosts the phase even more in the area of concern.

图 8 shows a TINA simulation of the bode plot without the noise gain implemented and 图 9 shows the result of the noise gain.



图 8. TINA-TI™ Stability Analysis of EC Mirror Driver Without Compensation



图 9. TINA-TI™ Stability Analysis of EC Mirror Driver With Compensation

### 2.3.3.3 Fast Discharge of Large Capacitive Load

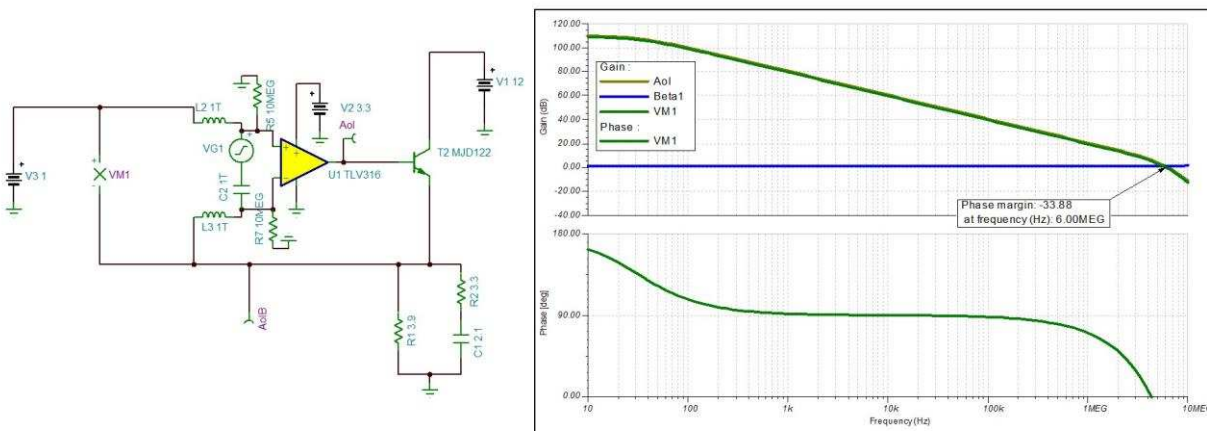
If the voltage applied to the mirror is set to 0 V, the capacitance on the mirror slowly discharges and the electrochromic element returns to a transparent, non-colored state. To accelerate the discharge of the capacitive load and reduce the amount of time to reach the transparent state, use a low-side transistor.

This simple open-drain transistor can be turned on by pulling the base high, which provides a direct path to ground for the capacitance on the mirror. Take care to ensure this transistor is only enabled when the output of the DAC has already been set to 0 V to prevent unnecessary current flow through the voltage buffer output and this transistor.

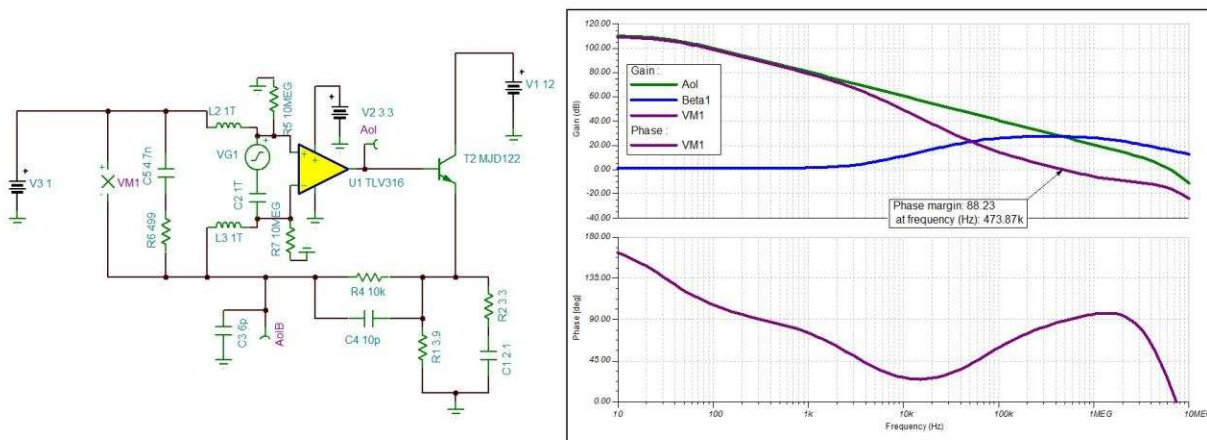
The base of this transistor is tied to a GPIO on the MCU which controls this design. Use a local pullup resistor of 4.7 kΩ with the open-drain output of the MCU GPIO.

图 10 shows the EC mirror driver schematic.



图 10. EC Mirror Driver Schematic

### 2.3.4 Linear Regulator

This design uses a single 3.3-V output TPS7B6933-Q1 linear dropout regulator (LDO) to power all components on the design. This device has a wide input voltage range for operation and protection for the entire possible battery operating voltage range.

The TPS7B6933-Q1 requires both input and output voltage decoupling. The device data sheet recommends that the input capacitor be larger than 0.1  $\mu\text{F}$  and the output capacitor be between 2.2  $\mu\text{F}$  and 100  $\mu\text{F}$ . A 4.7- $\mu\text{F}$  value is chosen for the input capacitor and 2.2  $\mu\text{F}$  is used as an output capacitor.

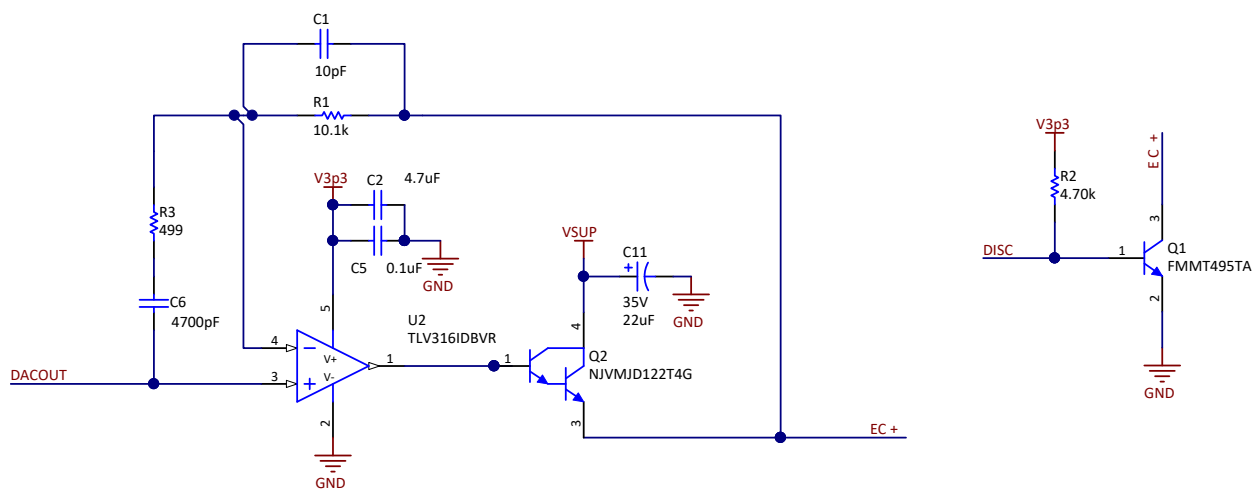
图 11 shows the LDO configuration schematic.



图 11. LDO Configuration Schematic

### 3 Hardware, Software, Testing Requirements, and Test Results

#### 3.1 Required Hardware and Software

##### 3.1.1 Hardware

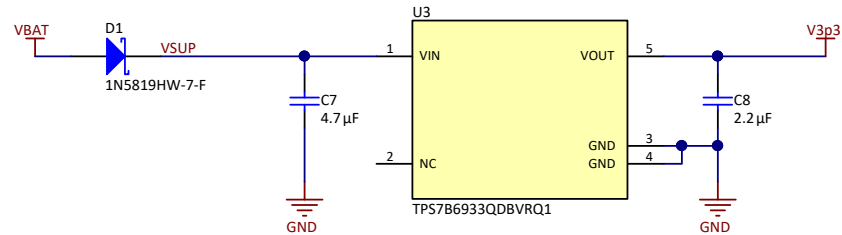
The TIDA-01539 reference design requires the use of an MCU for full functionality. The design has been outfitted with 10x1 connectors to connect to a MSP-EXP430G2552 LaunchPad.

The reference design board provides jumper J1 for tying a typical automotive battery voltage of 12 V to the design. The 3.3-V output of the LDO has been tied to the appropriate pin to also power the MSP430 LaunchPad from this power supply.

The designer can connect an electrochromic mirror to the design using jumper J2.

A simple firmware was developed for the MSP430 MCU to test the board to capture the OPT3001 value, write an appropriate value to the DAC, and monitor and control the GPIOs.

图 12 shows the schematic of the jumper connections and 图 13 shows an image of reference design connected to the MSP-EXP430G2552 LaunchPad.



图 12. Schematic of Jumper Connections



图 13. Image of TIDA-01539 Connected to MSP-EXP430G2552 LaunchPad™

## 3.2 Testing and Results

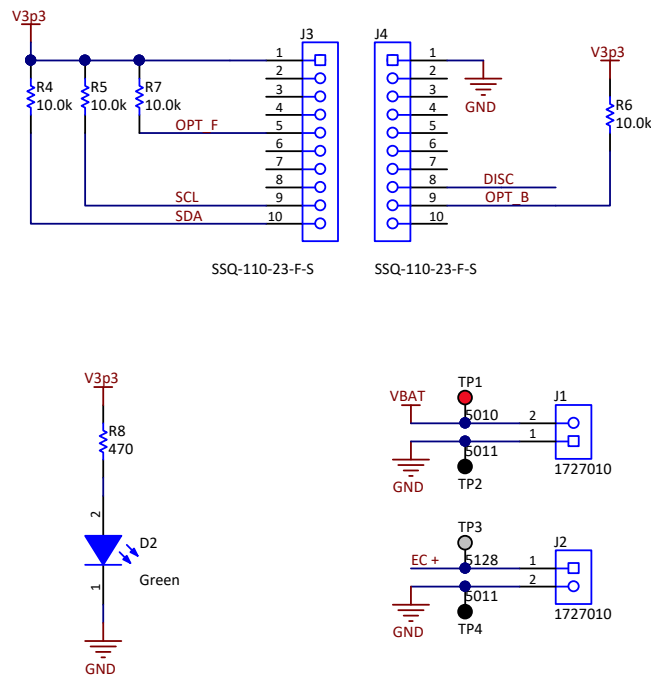
### 3.2.1 Test Setup

The testing was performed with the TIDA-01539 PCB and the MSP-EXP430G2552 Launchpad. A 12-V power supply was connected to J1 and a standard Licon electrochromic mirror was connected to J2. Multiple firmware algorithms were utilized for different testing modes. 图 14 shows an image of the test setup and provides the electrical specifications for the Licon mirror.

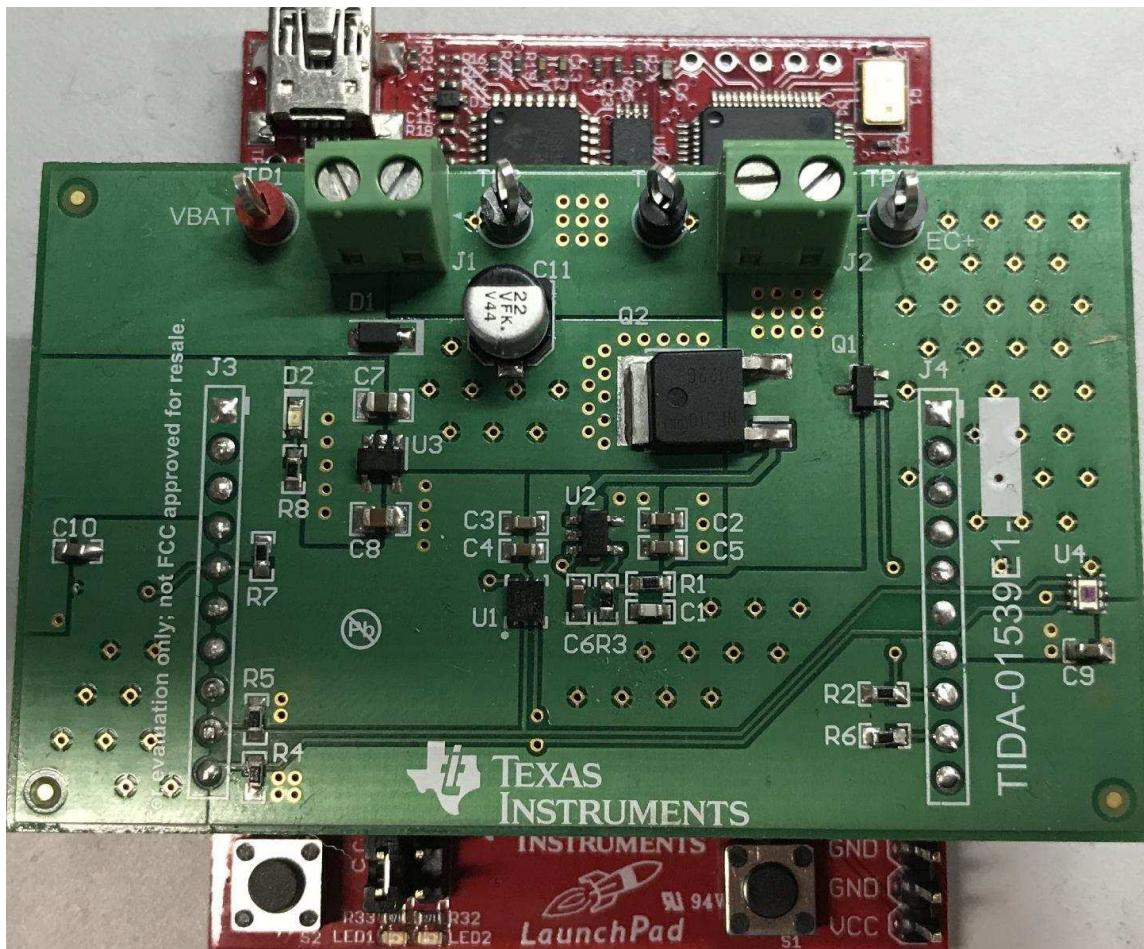

图 14. TIDA-01539 Test Setup

表 5. Licon 4th Layer Reflectance Electrochromic Mirror Specifications

Item	Specification
Operating Voltage	0 - 1.45 VDC
Peak Current	≤350 mA @ 1.2V
Average Current	≤180 mA @ 1.2 V
Operating Temperature	-40 °C to 85 °C
Time to Change (65% to 15% opacity, 25°C)	≤8 Sec (1.4V applied to mirror)
Time to Change (15% to 65% opacity, 25°C, no additional fast discharge)	≤10 Sec (0V applied to mirror)

### 3.2.2 Test Results

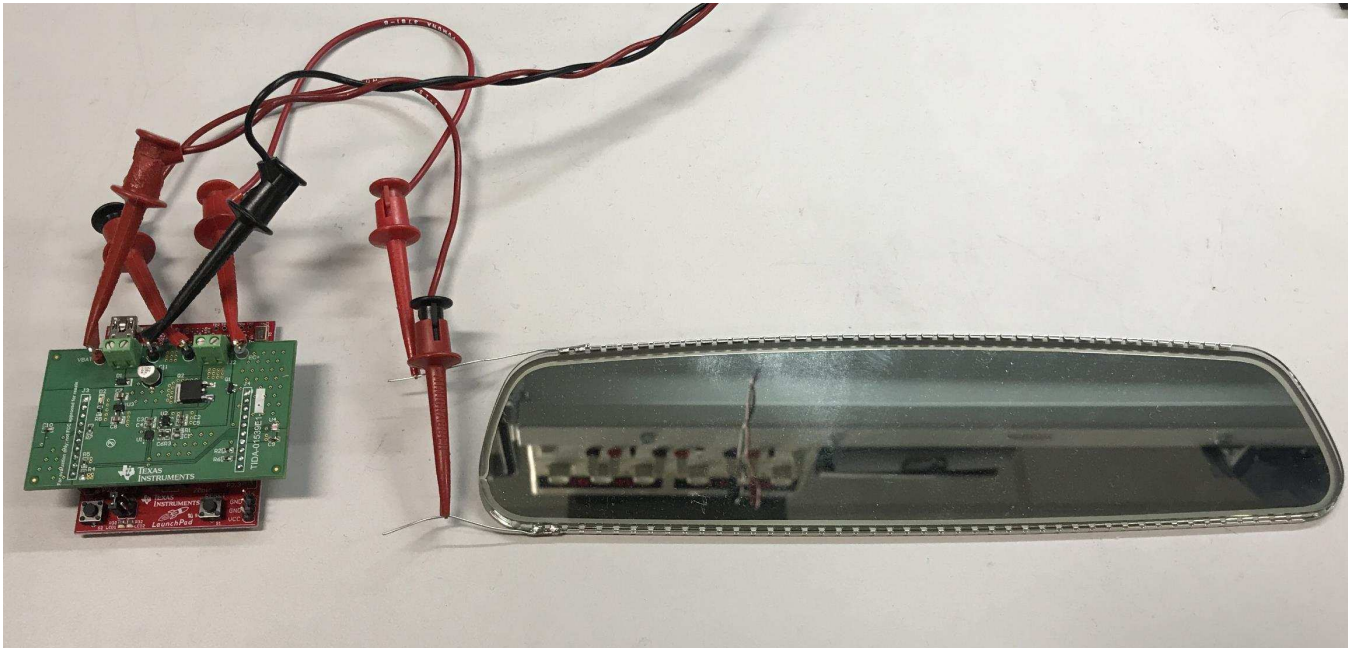
#### 3.2.2.1 EC Mirror Driver Stability

A simple program was created to maintain the DAC drive from 0 V to 1.5 V and monitor the impulse response of the EC mirror driver for stability with a large capacitive load. Aside from a slight overshoot, the design shows no stability issues (see 图 15).



图 15. Impulse Response of EC Mirror Driver Stage With Typical Electrochromic Load

### 3.2.3 Fast Discharge of Mirror

The design was tested with and without the fast discharge transistor, which was used to show its affect on the amount of time required for the mirror to return to its completely transparent state.

This test drives the mirror from 1.5 V to 0 V and then measures the voltage monitored across the mirror as it discharges.

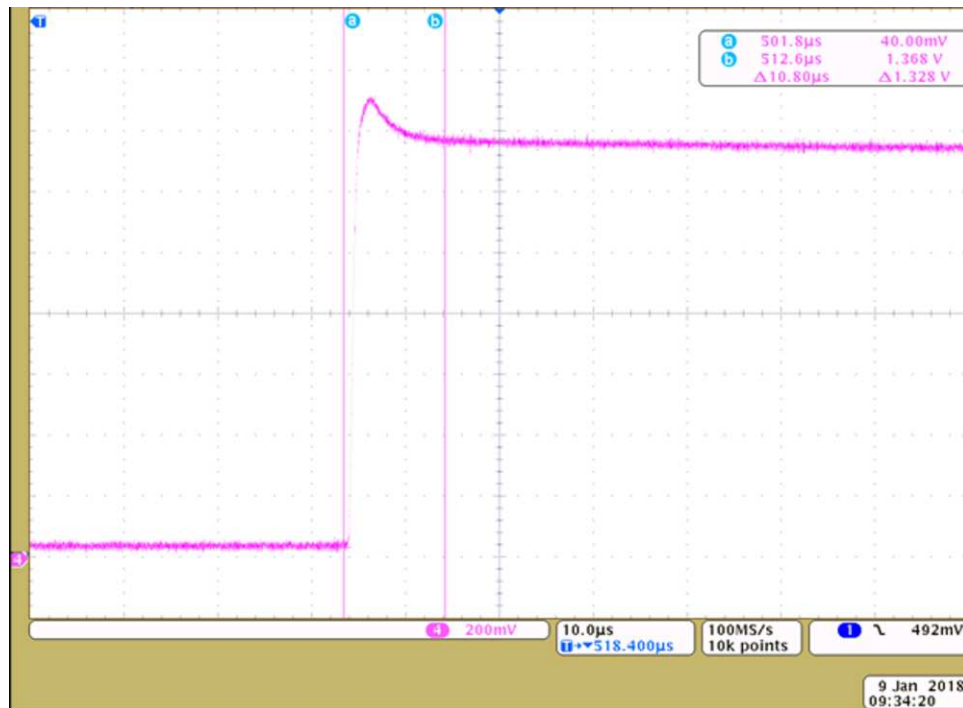
Without the circuit, discharge of the mirror takes more than 20 seconds to reach 0 V and a completely clear state (see 图 16).

To implement the fast discharge, set the DAC to drive to 0 V, after which the MCU waits about 200 ms and then pulls the transistor base high. The mirror then discharges completely to 0 V within an instant and returns to a completely clear state within a few seconds (see 图 17).





图 16. Discharge of Capacitive Load Without Fast Discharge Circuit



图 17. Discharge of Capacitive Load With Fast Discharge Enabled

## 4 Design Files

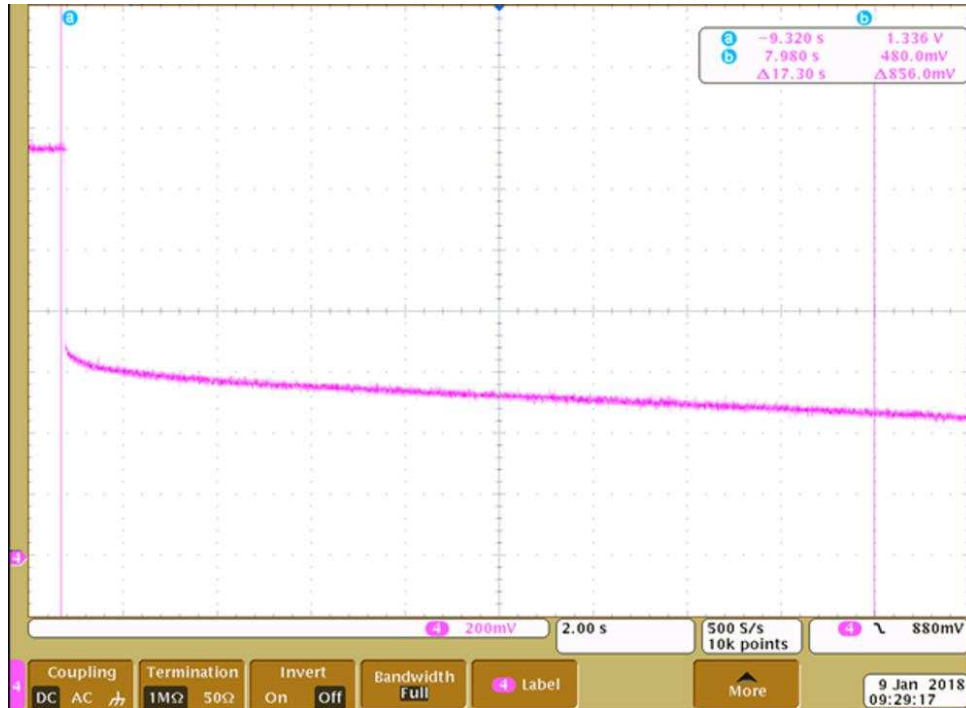
### 4.1 Schematics

To download the schematics, see the design files at [TIDA-01539](#).

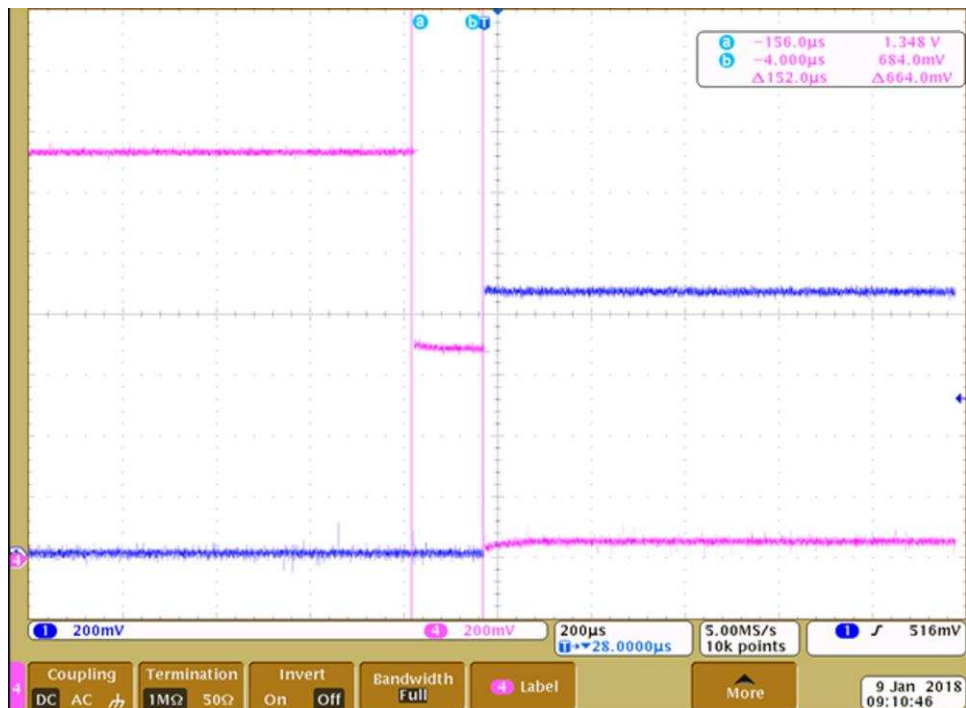
### 4.2 Bill of Materials

To download the bill of materials (BOM), see the design files at [TIDA-01539](#).

### 4.3 PCB Layout Recommendations

#### 4.3.1 Layout Prints

To download the layer plots, see the design files at [TIDA-01539](#).

### 4.4 Altium Project

To download the Altium project files, see the design files at [TIDA-01539](#).

### 4.5 Gerber Files

To download the Gerber files, see the design files at [TIDA-01539](#).

### 4.6 Assembly Drawings

To download the assembly drawings, see the design files at [TIDA-01539](#).

## 5 Software Files

To download the software files, see the design files at [TIDA-01539](#).

## 6 Related Documentation

1. Texas Instruments, [OPT3001: Ambient Light Sensor Application Guide](#)

### 6.1 商标

E2E, MSP430, LaunchPad, TINA-TI are trademarks of Texas Instruments. All other trademarks are the property of their respective owners.

## 7 Terminology

**BJT**— Bipolar junction transistor

**DAC**— Digital-to-analog converter

**EC**— Electrochromic mirror

**EMI**— Electromagnetic interference

**ESD**— Electrostatic discharge

**GPIO**— General-purpose input/output (pins)

**HBM**— Human body model

**IR**— Infrared

**LDO**— Low-dropout linear regulator

**LSB**— Least significant bit

**MCU**— Microcontroller

**MSB**— Most significant bit

**PCB**— Printed-circuit board

**RFI**— Radio frequency interference

## **8 About the Author**

**MATTHEW SULLIVAN** is a systems engineer at Texas Instruments. As a member of the Automotive Systems Engineering team, Matt focuses on body electronics and lighting, creating block diagrams and reference designs for automotive customers. Matt acquired his B.S.E.E. in 2012 from the University of Southern California in Los Angeles, CA.

## 有关 TI 设计信息和资源的重要通知

德州仪器 (TI) 公司提供的技术、应用或其他设计建议、服务或信息，包括但不限于与评估模块有关的参考设计和材料（总称“TI 资源”），旨在帮助设计人员开发整合了 TI 产品的应用；如果您（个人，或如果是代表贵公司，则为贵公司）以任何方式下载、访问或使用了任何特定的 TI 资源，即表示贵方同意仅为该等目标，按照本通知的条款进行使用。

TI 所提供的 TI 资源，并未扩大或以其他方式修改 TI 对 TI 产品的公开适用的质保及质保免责声明；也未导致 TI 承担任何额外的义务或责任。TI 有权对其 TI 资源进行纠正、增强、改进和其他修改。

您理解并同意，在设计应用时应自行实施独立的分析、评价和判断，且应全权负责并确保应用的安全性，以及您的应用（包括应用中使用的 TI 产品）应符合所有适用的法律法规及其他相关要求。就您的应用声明，您具备制订和实施下列保障措施所需的一切必要专业知识，能够 (1) 预见故障的危险后果，(2) 监视故障及其后果，以及 (3) 降低可能导致危险的故障几率并采取适当措施。您同意，在使用或分发包含 TI 产品的任何应用前，您将彻底测试该等应用和该等应用所用 TI 产品的功能而设计。除特定 TI 资源的公开文档中明确列出的测试外，TI 未进行任何其他测试。

您只有在为开发包含该等 TI 资源所列 TI 产品的应用时，才被授权使用、复制和修改任何相关单项 TI 资源。但并未依据禁止反言原则或其他法律授予您任何 TI 知识产权的任何其他明示或默示的许可，也未授予您 TI 或第三方的任何技术或知识产权的许可，该等许可包括但不限于任何专利权、版权、屏蔽作品权或与使用 TI 产品或服务的任何整合、机器制作、流程相关的其他知识产权。涉及或参考了第三方产品或服务的信息不构成使用此类产品或服务的许可或与其相关的保证或认可。使用 TI 资源可能需要您向第三方获得对该等第三方专利或其他知识产权的许可。

TI 资源系“按原样”提供。TI 兹免除对 TI 资源及其使用作出所有其他明确或默示的保证或陈述，包括但不限于对准确性或完整性、产权保证、无屡发故障保证，以及适销性、适合特定用途和不侵犯任何第三方知识产权的任何默认保证。

TI 不负责任何申索，包括但不限于因组合产品所致或与之有关的申索，也不为您辩护或赔偿，即使该等产品组合已列于 TI 资源或其他地方。对因 TI 资源或其使用引起或与之有关的任何实际的、直接的、特殊的、附带的、间接的、惩罚性的、偶发的、从属或惩戒性损害赔偿，不管 TI 是否获悉可能会产生上述损害赔偿，TI 概不负责。

您同意向 TI 及其代表全额赔偿因您不遵守本通知条款和条件而引起的任何损害、费用、损失和/或责任。

本通知适用于 TI 资源。另有其他条款适用于某些类型的材料、TI 产品和服务的使用和采购。这些条款包括但不限于适用于 TI 的半导体产品 (<http://www.ti.com/sc/docs/stdterms.htm>)、[评估模块](http://www.ti.com/sc/docs/sampters.htm)和样品 (<http://www.ti.com/sc/docs/sampters.htm>) 的标准条款。

邮寄地址：上海市浦东新区世纪大道 1568 号中建大厦 32 楼，邮政编码：200122  
Copyright © 2018 德州仪器半导体技术（上海）有限公司