

TVS1401 14V 双向平缓钳位浪涌保护器件

1 特性

- 提供功能安全
 - 可帮助进行功能安全系统设计的文档
- 保护特性符合针对工业信号线路的 $\pm 1\text{kV}$ 、 $42\ \Omega$ IEC 61000-4-5 浪涌测试要求
- 双向极性可针对双极信号传输或误接线情形提供保护
- 30A 8/20 μs 浪涌电流下的钳位电压为 20.5V
- 关断电压： $\pm 14\text{V}$
- 3mm \times 3mm 小型 SON 封装
- 在 125°C 时，可耐受超过 5,000 次的 30A 8/20 μs 浪涌电流的重复冲击
- 强大的浪涌保护
 - IEC61000-4-5 (8/20 μs) : 30A
 - IEC61643-321 (10/1000 μs) : 6A
- 低泄漏电流
 - 27°C 下为 1.1nA (典型值)
 - 85°C 时的最大值为 260nA
- 低电容：68pF
- 集成 4 级 IEC 61000-4-2 ESD 保护

2 应用

- 工业传感器 I/O
- 固态硬盘
- 电机驱动器
- 12V 电源线路
- 电器
- 医疗设备
- 电网保护和控制

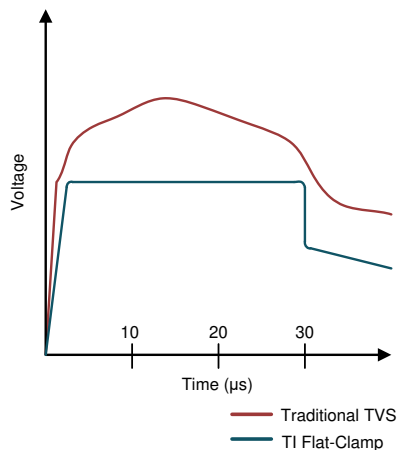

对 8/20 μs 浪涌事件的电压钳位响应

3 说明

TVS1401 器件可将高达 30A 的 IEC 61000-4-5 故障电流进行分流，以保护系统免受高功率瞬态冲击或雷击。该器件可通过 $42\ \Omega$ 阻抗进行耦合的方式承受 1kV 的 IEC 61000-4-5 开路电压，满足常见的工业信号线路 EMC 要求。TVS1401 使用反馈机制确保在故障期间发挥精确的平缓钳位能力，使系统接触电压始终低于传统 TVS 二极管。精确的电压调节允许设计人员放心地选择具有较低电压容差的系统组件，从而能够在不影响可靠性的情况下降低系统成本和复杂度。TVS1401 具有 $\pm 14\text{V}$ 的工作范围，可在需要反向接线情形防护的系统中运行。

此外，TVS1401 采用小型 SON 封装，专为空间受限的应用而设计，与标准 SMA 和 SMB 封装相比，其尺寸显著减小。低器件泄露电流和电容确保最大限度地降低了对受保护线路的影响。为了确保在产品的整个寿命期间提供可靠保护，TI 在 125°C 的环境下对 TVS1401 进行了 5,000 次重复浪涌冲击测试，但器件性能未发生任何变化。

器件信息(1)

器件型号	封装	封装尺寸 (标称值)
TVS1401	SON (8)	3.00mm \times 3.00mm

(1) 如需了解所有可用封装，请参阅数据表末尾的可订购产品附录。

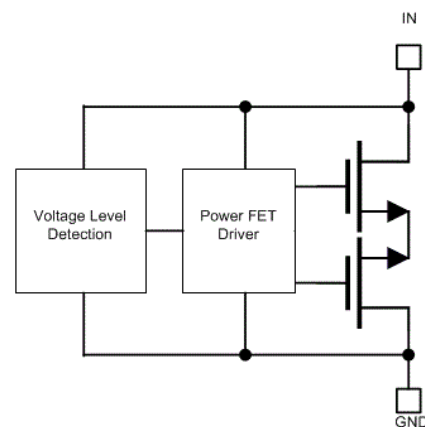

功能方框图



Table of Contents

1 特性	1	9.3 Feature Description.....	8
2 应用	1	9.4 Device Functional Modes.....	8
3 说明	1	10 Application and Implementation	10
4 Revision History	2	10.1 Application Information.....	10
5 说明 (续)	3	10.2 Typical Application.....	10
6 Device Comparison Table	3	11 Power Supply Recommendations	11
7 Pin Configuration and Functions	4	12 Layout	12
8 Specifications	5	12.1 Layout Guidelines.....	12
8.1 Absolute Maximum Ratings.....	5	12.2 Layout Example.....	12
8.2 ESD Ratings - JEDEC.....	5	13 Device and Documentation Support	13
8.3 ESD Ratings - IEC.....	5	13.1 Documentation Support.....	13
8.4 Recommended Operating Conditions.....	5	13.2 接收文档更新通知.....	13
8.5 Thermal Information.....	5	13.3 支持资源.....	13
8.6 Electrical Characteristics.....	6	13.4 Trademarks.....	13
8.7 Typical Characteristics.....	7	13.5 Electrostatic Discharge Caution.....	13
9 Detailed Description	8	13.6 术语表.....	13
9.1 Overview.....	8	14 Mechanical, Packaging, and Orderable Information	13
9.2 Functional Block Diagram.....	8		

4 Revision History

注：以前版本的页码可能与当前版本的页码不同

Changes from Revision A (December 2018) to Revision B (November 2021)	Page
• 更新了整个文档中的表格、图和交叉参考的编号格式.....	1
• 更新了 <i>特性</i> 部分，以添加“提供功能安全型”文本.....	1

Changes from Revision * (September 2018) to Revision A (December 2018)	Page
• 将“预告信息”更改为“量产数据”.....	1

5 说明 (续)

TVS1401 是 TI 的平缓钳位系列浪涌器件中的一款产品。如需深入了解平缓钳位系列，请参阅《[用于高效系统保护的平缓钳位浪涌保护技术](#)》白皮书。

6 Device Comparison Table

DEVICE	V_{rwm}	V_{clamp} at I_{pp}	I_{pp} (8/20 μ s)	Leakage @ V_{rwm}	POLARITY	Package
TVS0500	5	9.2 V	43 A	0.07 nA	Unidirectional	DRV (SON-6)
TVS0701	7	11 V	30 A	0.25 nA	Bidirectional	DRB (SON-8)
TVS1400	14	18.6 V	43 A	2 nA	Unidirectional	DRV (SON-6)
TVS1401	14	20.5 V	30 A	1.1 nA	Bidirectional	DRB (SON-8)
TVS1800	18	22.8 V	40 A	0.3 nA	Unidirectional	DRV (SON-6)
TVS1801	18	27.4 V	30 A	0.4 nA	Bidirectional	DRB (SON-8)
TVS2200	22	27.7 V	40 A	3.2 nA	Unidirectional	DRV (SON-6)
TVS2201	22	29.6 V	30 A	2 nA	Bidirectional	DRB (SON-8)
TVS2700	27	32.5 V	40 A	1.7 nA	Unidirectional	DRV (SON-6)
TVS2701	27	34 V	27 A	0.8 nA	Bidirectional	DRB (SON-8)
TVS3300	33	38 V	35 A	19 nA	Unidirectional	DRV (SON-6), YZF (WCSP)
TVS3301	33	40 V	27 A	2.5 nA	Bidirectional	DRB (SON-8)

7 Pin Configuration and Functions



图 7-1. DRB Package
8-Pin SON
Top View

Pin Functions

PIN		TYPE	DESCRIPTION
NAME	DRB		
FLOAT	Exposed Thermal Pad	NC	Exposed Thermal Pad Must Be Floating
GND	5, 6, 7, 8	GND	Ground
IN	1, 2, 3, 4	IN	Surge Protected Channel

8 Specifications

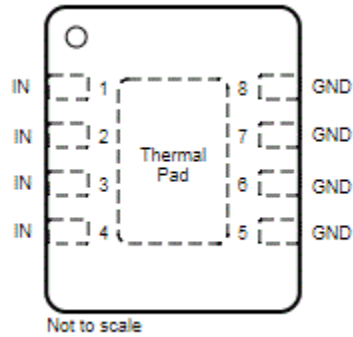
8.1 Absolute Maximum Ratings

$T_A = 27^\circ\text{C}$ (unless otherwise noted)⁽¹⁾

		MIN	MAX	UNIT
Maximum Surge	IEC 61000-4-5 Current (8/20 μs), $T_A < 125^\circ\text{C}$		± 30	A
	IEC 61000-4-5 Power (8/20 μs)		600	W
	IEC 61643-321 Current (10/1000 μs)		± 6	A
	IEC 61643-321 Power (10/1000 μs)		120	W
EFT	IEC 61000-4-4 EFT Protection		± 80	A
I_{BR}	DC Current		45	mA
T_A	Ambient Operating Temperature	-40	125	$^\circ\text{C}$
T_{stg}	Storage Temperature	-65	125	$^\circ\text{C}$

- (1) Stresses beyond those listed under *Absolute Maximum Rating* may cause permanent damage to the device. These are stress ratings only, which do not imply functional operation of the device at these or any other conditions beyond those indicated under *Recommended Operating Condition*. Exposure to absolute-maximum-rated conditions for extended periods may affect device reliability.

8.2 ESD Ratings - JEDEC

			VALUE	UNIT
$V_{(ESD)}$	Electrostatic discharge	Human body model (HBM), per ANSI/ESDA/JEDEC JS-001, all pins ⁽¹⁾	± 2000	V
		Charged device model (CDM), per JEDEC specification JESD22-C101, all pins ⁽²⁾	± 500	

- (1) JEDEC document JEP155 states that 500-V HBM allows safe manufacturing with a standard ESD control process.
(2) JEDEC document JEP157 states that 250-V CDM allows safe manufacturing with a standard ESD control process.

8.3 ESD Ratings - IEC

			VALUE	UNIT
$V_{(ESD)}$	Electrostatic discharge	IEC 61000-4-2 contact discharge	± 8	kV
		IEC 61000-4-2 air-gap discharge	± 15	

8.4 Recommended Operating Conditions

over operating free-air temperature range (unless otherwise noted)

		MIN	NOM	MAX	UNIT
V_{RWM}	Reverse Stand-Off Voltage		± 14		V

8.5 Thermal Information

THERMAL METRIC ⁽¹⁾		TVS1401	UNIT
		DRB (SON)	
		8 PINS	
R_{qJA}	Junction-to-ambient thermal resistance	52.0	$^\circ\text{C}/\text{W}$
$R_{qJC(top)}$	Junction-to-case (top) thermal resistance	56.1	$^\circ\text{C}/\text{W}$
R_{qJB}	Junction-to-board thermal resistance	24.9	$^\circ\text{C}/\text{W}$
Y_{JT}	Junction-to-top characterization parameter	2.1	$^\circ\text{C}/\text{W}$
Y_{JB}	Junction-to-board characterization parameter	24.8	$^\circ\text{C}/\text{W}$
$R_{qJC(bot)}$	Junction-to-case (bottom) thermal resistance	9.8	$^\circ\text{C}/\text{W}$

- (1) For more information about traditional and new thermal metrics, see the [Semiconductor and IC Package Thermal Metrics](#) application report.

8.6 Electrical Characteristics

over operating free-air temperature range (unless otherwise noted)

PARAMETER		TEST CONDITIONS	MIN	TYP	MAX	UNIT
I _{LEAK}	Leakage Current	Measured at V _{IN} = ±V _{RWM} , T _A = 27°C		1.1	30	nA
		Measured at V _{IN} = ±V _{RWM} , T _A = 85°C			260	
V _{BR}	Break-down Voltage	I _{IN} = ±1mA	17.1	17.6		V
V _{CLAMP}	Clamp Voltage	±I _{pp} IEC 61000-4-5 Surge (8/20 μs), V _{IN} = 0 V before surge, T _A = 27°C		20.5	22.2	V
		±I _{pp} IEC 61000-4-5 Surge (8/20 μs), V _{IN} = ±V _{RWM} before surge, T _A = 125°C			23.55	
R _{DYN}	8/20 μs surge dynamic resistance	Calculated from V _{CLAMP} at .5*I _{pp} and I _{pp} surge current, T _A = 25°C		70		mΩ
C _{IN}	Input pin capacitance	V _{IN} = V _{RWM} , f = 1 MHz, 30 mV _{pp} , IO to GND		68		pF
SR	Maximum Slew Rate	0-±V _{RWM} rising edge, sweep rise time and measure slew rate when I _{PEAK} = 1 mA, T _A = 27°C		2.5		V/μs
		0-±V _{RWM} rising edge, sweep rise time and measure slew rate when I _{PEAK} = 1 mA, T _A = 85°C		1		

8.7 Typical Characteristics



图 8-1. 8/20 μs Surge Response at 30 A



图 8-2. 8/20 μs Surge Clamping Response at 30 A

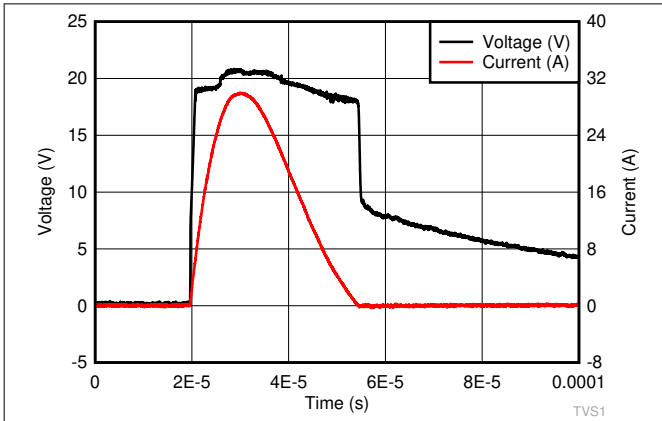

f = 1 MHz, 30 mVpp, IO to GND

图 8-3. Capacitance vs Voltage Bias

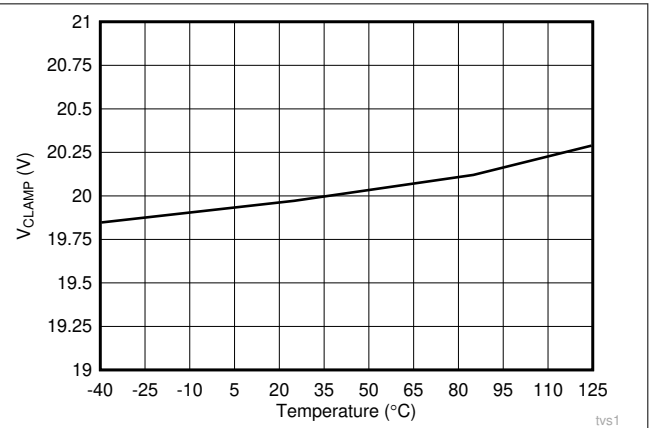
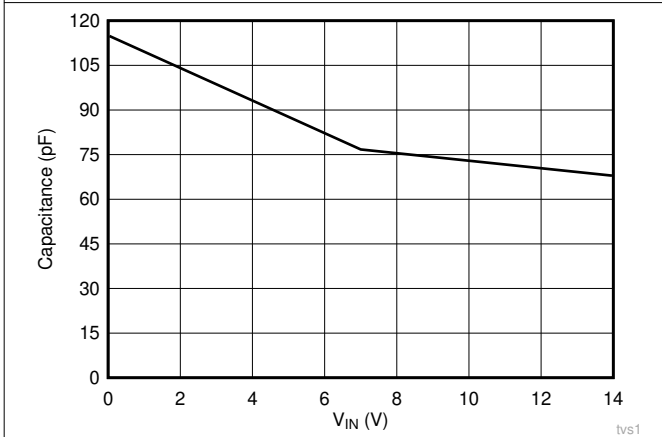

图 8-4. Leakage Current vs Temperature at ±14 V



图 8-5. Breakdown Voltage (1 mA) vs Temperature

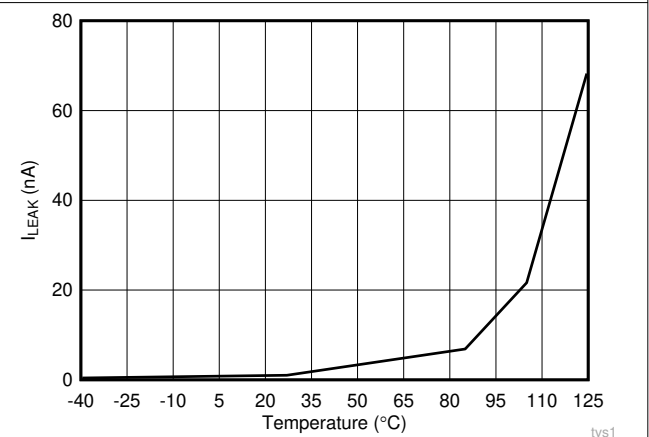

图 8-6. Dynamic Leakage vs Signal Slew Rate across Temperature

9 Detailed Description

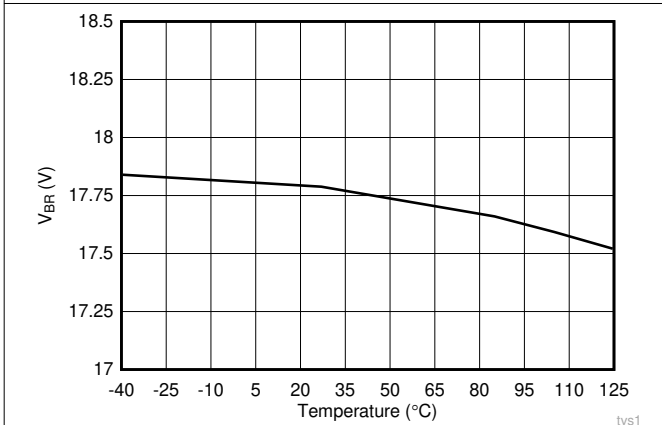
9.1 Overview

The TVS1401 is a bidirectional precision clamp with two integrated FETs driven by a feedback loop to tightly regulate the input voltage during an overvoltage event. This feedback loop leads to a very low dynamic resistance, giving a flat clamping voltage during transient overvoltage events like a surge.

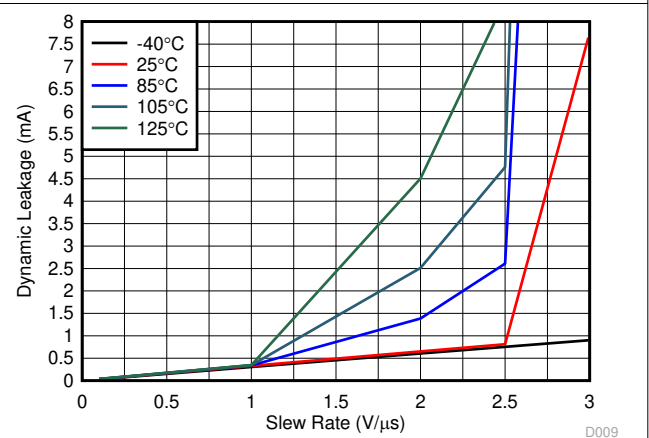
9.2 Functional Block Diagram

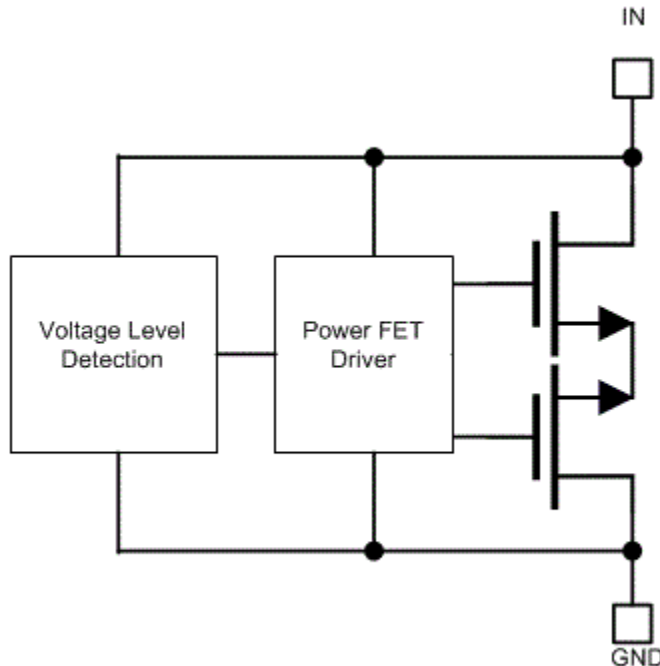

9.3 Feature Description

The TVS1401 is a precision clamp that handles ± 30 A of IEC 61000-4-5 8/20 μ s surge pulse. The flat clamping feature helps keep the clamping voltage very low to keep the downstream circuits from being stressed. The flat clamping feature can also help end-equipment designers save cost by opening up the possibility to use lower-cost, lower voltage tolerant downstream ICs. This device provides a bidirectional operating range, with a symmetrical V_{RWM} of ± 14 V, which is designed for applications that have bipolar input signals or that must withstand reverse wiring conditions. The TVS1401 has minimal leakage at V_{RWM} designed for applications where low leakage and power dissipation is a necessity. Built-in IEC 61000-4-2 and IEC 61000-4-4 ratings make it a robust protection solution for ESD and EFT events, and the TVS1401 wide ambient temperature range of -40°C to $+125^\circ\text{C}$ enables usage in harsh industrial environments.

9.4 Device Functional Modes

9.4.1 Protection Specifications

The TVS1401 is specified according to both the IEC 61000-4-5 and IEC 61643-321 standards. This enables usage in systems regardless of which standard is required by relevant product standards or best matches measured fault conditions. The IEC 61000-4-5 standard requires protection against a pulse with a rise time of 8 μ s and a half-length of 20 μ s, while the IEC 61643-321 standard requires protection against a much longer pulse with a rise time of 10 μ s and a half-length of 1000 μ s.

The positive and negative surges are imposed to the TVS1401 by a combination wave generator (CWG) with a $2\text{-}\Omega$ coupling resistor at different peak voltage levels. For powered-on transient tests that need power supply bias, inductances are used to decouple the transient stress and protect the power supply. The TVS1401 is post-tested by assuring that there is no shift in device breakdown or leakage at V_{RWM} .

In addition, the TVS1401 has been tested according to IEC 61000-4-5 to pass a ± 1 -kV surge test through a 42- Ω coupling resistor and a 0.5- μ F capacitor. This test is a common test requirement for industrial signal I/O lines and the TVS1401 precision clamp can be used in applications that have that requirement.

The TVS1401 integrates IEC 61000-4-2 level 4 ESD Protection and 80 A of IEC 61000-4-4 EFT Protection. These combine to ensure that the device can protect against most common transient test requirements.

For more information on TI's test methods for Surge, ESD, and EFT testing, refer to the [TI's IEC 61000--4-x Tests for TI's Protection Devices](#) application report.

9.4.2 Reliability Testing

To ensure device reliability, the TVS1401 is characterized against 5,000 repetitive pulses of 25-A IEC 61000-4-5 8/20- μ s surge pulses at 125°C. The test is performed with less than 10 seconds between each pulse at high temperature to simulate worst-case scenarios for fault regulation. After each surge pulse, the TVS1401 clamping voltage, breakdown voltage, and leakage are recorded to ensure that there is no variation or performance degradation. By ensuring robust, reliable, high temperature protection, the TVS1401 enables fault protection in applications that must withstand years of continuous operation with no performance change.

9.4.3 Zero Derating

Unlike traditional diodes, the TVS1401 has zero derating of maximum power dissipation and ensures robust performance up to 125°C. Traditional TVS diodes lose up to 50% of their current carrying capability when at high temperatures, so a surge pulse above 85°C ambient can cause failures that are not seen at room temperature. The TVS1401 prevents this so the designer can see the surge protection regardless of temperature. Because of this, Flat-Clamp devices can provide robust protection against surge pulses that occur at high ambient temperatures, as shown in TI's [TVS Surge Protection in High-Temperature Environments](#) application report.

9.4.4 Bidirectional Operation

The TVS1401 is a bidirectional TVS with a symmetrical operating region. This allows for operation with positive and negative voltages, rather than just positive voltages like the unidirectional TVS1400. This allows for single chip protection for applications where the signal is expected to operate below 0 V or where there is a need to withstand a large common-mode voltage. In addition, in many cases, there is a system requirement to be able to withstand reverse wiring conditions, in many cases where a high voltage signal is accidentally applied to the system ground and a ground is accidentally applied to the input terminal. This causes a large reverse voltage on the TVS diode that the device must be able to withstand. The TVS1401 is designed to not break down or see failures under reverse wiring conditions for applications that must withstand these miswiring issues.

Note

If the applied signal is not expected to go below 0 V, an unidirectional device will clamp much lower in the reverse direction and should be used. In this case, the recommended device would be the TVS1400.

9.4.5 Transient Performance

During large transient swings, the TVS1401 will begin clamping the input signal to protect downstream conditions. While this prevents damage during fault conditions, it can cause leakage when the intended input signal has a fast slew rate. To keep power dissipation low and remove the chance of signal distortion, TI recommends that the designer keep the slew rate of any input signal on the TVS1401 below 2.5 V/ μ s at room temperature and below 1 V/ μ s at 85°C as shown in [Figure 8-6](#). Faster slew rates will cause the device to clamp the input signal and draw current through the device for a few microseconds, increasing the rise time of the signal. This will not cause any harm to the system or to the device, however, it can cause device overheating if the fast input voltage swings occur regularly.

10 Application and Implementation

Note

以下应用部分中的信息不属于 TI 器件规格的范围，TI 不担保其准确性和完整性。TI 的客户应负责确定器件是否适用于其应用。客户应验证并测试其设计，以确保系统功能。

10.1 Application Information

The TVS1401 can be used to protect any power, analog, or digital signal from transient fault conditions caused by the environment or other electrical components.

10.2 Typical Application



图 10-1. TVS1401 Application Schematic

10.2.1 Design Requirements

A typical operation for the TVS1401 would be protecting in a factory control application and protecting an analog input to an ADC input similar to 图 10-1. In this example, the TVS1401 is protecting the input to an ADS8689, an ADC with an input voltage range of ± 12.288 V and an absolute maximum input voltage range of ± 20 V. Without any input protection, this input voltage will rise to hundreds of volts for multiple microseconds, and violate the absolute maximum input voltage and harm the device if a surge event is caused by lightning, coupling, ringing, or any other fault condition. TI's Flat-Clamp technology provides surge protection diodes that can maximize the useable voltage range at a safe level for the system.

10.2.2 Detailed Design Procedure

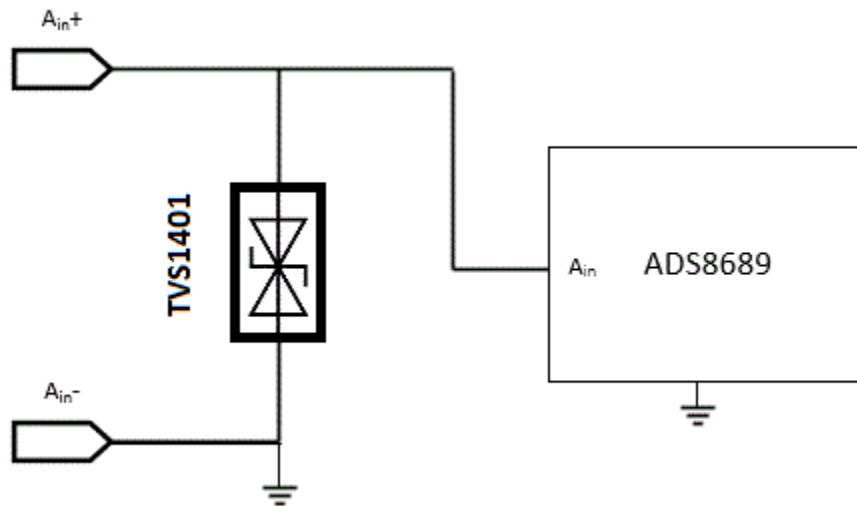
If the TVS1401 is in place to protect the device, the voltage will rise to the breakdown of the diode at 17.6 V during a surge event. The TVS0701 will then turn on to shunt the surge current to ground. With the low dynamic resistance of the TVS1401, large amounts of surge current will have minimal impact on the clamping voltage. The dynamic resistance of the TVS1401 is around 70 m Ω , which means a 25-A surge current will cause a voltage raise of $25 \text{ A} \times 70 \text{ m}\Omega = 1.75 \text{ V}$. Because the device turns on at 17.6 V, this means the ADC input will be exposed to a maximum of $17.6 \text{ V} + 1.75 \text{ V} = 19.35 \text{ V}$ during surge pulses, well within the ADS8689 absolute maximum to ensure robust protection of the circuit. The same magnitude of voltage will be seen during a negative pulse, still safely protecting the system.

In addition, the low leakage and capacitance of the TVS1401 assures low input distortion. At 14 V, giving margin on the ± 12.288 V range of the ADS8689, the device will see typical 1.1-nA leakage, which will have minimal

effect on the overall system. The TVS1401 low capacitance of 68 pF will also cause less effect on signal integrity compared to industry standard devices like the SMBJ14CA which has 1500 pF of capacitance and can cause up to 3 dB of THD attenuation in measured systems.

Finally, the small size of the device also improves fault protection by lowering the effect of fault current coupling onto neighboring traces. The small form factor of the TVS1401 allows the device to be placed extremely close to the input connector, which lowers the length of the path fault current going through the system compared to larger protection solutions.

10.2.3 Application Curves

When a surge is applied to a system with the TVS1401, the device will clamp the overvoltage to a safe level as shown in [Figure 10-2](#).

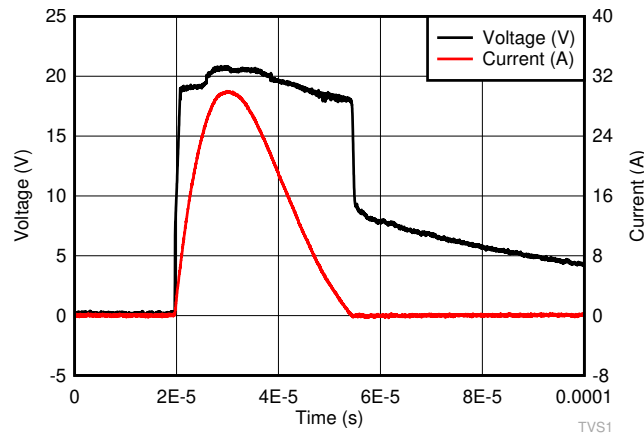

Figure 10-2. TVS1401 Surge Clamping Response

11 Power Supply Recommendations

The TVS1401 is a clamping device so there is no need to power it. To ensure the device functions properly, do not violate the recommended V_{IN} voltage range (-14 V to 14 V).

12 Layout

12.1 Layout Guidelines

The optimum placement is close to the connector. EMI during an ESD event can couple from the tested trace to other nearby unprotected traces, which could result in system failures. The PCB designer must minimize the possibility of EMI coupling by keeping all unprotected traces away from protected traces between the TVS and the connector. Route the protected traces straight. Use rounded corners with the largest radii possible to eliminate any sharp corners on the protected traces between the TVS1401 and the connector. Electric fields tend to build up on corners, which could increase EMI coupling.

Ensure that the thermal pad on the layout is floating rather than grounded. Grounding the thermal pad will impede the operating range of the TVS1401 and can cause failures when the applied voltage is negative. A floating thermal pad allows the maximum operating range without sacrificing any transient performance.

12.2 Layout Example



图 12-1. TVS1401 Layout

13 Device and Documentation Support

13.1 Documentation Support

13.1.1 Related Documentation

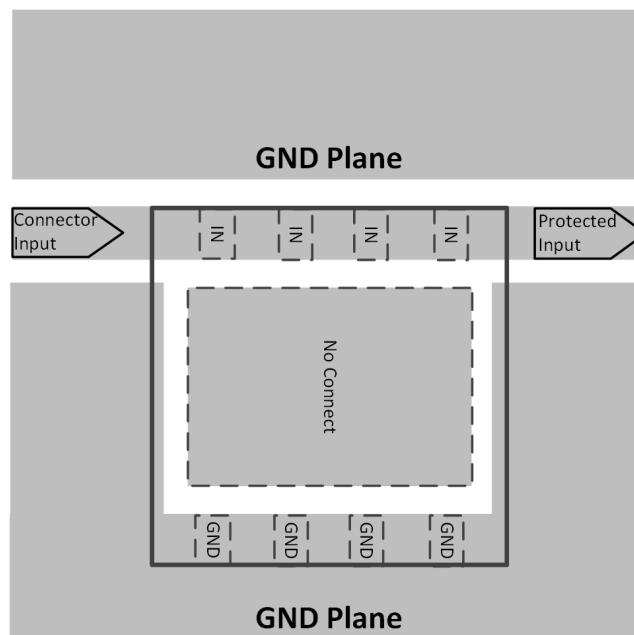
For related documentation, see the following:

- Texas Instruments, [Flat-Clamp Surge Protection Technology for Efficient System Protection white paper](#)
- Texas Instruments, [TI's IEC 61000--4-x Tests for TI's Protection Devices application report](#)
- Texas Instruments, [TVS Surge Protection in High-Temperature Environments application report](#)
- Texas Instruments, [TVS1401 Functional Safety, FIT Rate, Failure Mode Distribution and Pin FMA](#)

13.2 接收文档更新通知

要接收文档更新通知，请导航至 ti.com 上的器件产品文件夹。点击 [订阅更新](#) 进行注册，即可每周接收产品信息更改摘要。有关更改的详细信息，请查看任何已修订文档中包含的修订历史记录。

13.3 支持资源

[TI E2E™ 支持论坛](#) 是工程师的重要参考资料，可直接从专家获得快速、经过验证的解答和设计帮助。搜索现有解答或提出自己的问题可获得所需的快速设计帮助。

链接的内容由各个贡献者“按原样”提供。这些内容并不构成 TI 技术规范，并且不一定反映 TI 的观点；请参阅 TI 的 [《使用条款》](#)。

13.4 Trademarks

TI E2E™ is a trademark of Texas Instruments.

所有商标均为其各自所有者的财产。

13.5 Electrostatic Discharge Caution



This integrated circuit can be damaged by ESD. Texas Instruments recommends that all integrated circuits be handled with appropriate precautions. Failure to observe proper handling and installation procedures can cause damage.

ESD damage can range from subtle performance degradation to complete device failure. Precision integrated circuits may be more susceptible to damage because very small parametric changes could cause the device not to meet its published specifications.

13.6 术语表

[TI 术语表](#) 本术语表列出并解释了术语、首字母缩略词和定义。

14 Mechanical, Packaging, and Orderable Information

The following pages include mechanical, packaging, and orderable information. This information is the most current data available for the designated devices. This data is subject to change without notice and revision of this document. For browser-based versions of this data sheet, refer to the left-hand navigation.

PACKAGING INFORMATION

Orderable part number	Status (1)	Material type (2)	Package Pins	Package qty Carrier	RoHS (3)	Lead finish/ Ball material (4)	MSL rating/ Peak reflow (5)	Op temp (°C)	Part marking (6)
TVS1401DRBR	Active	Production	SON (DRB) 8	3000 LARGE T&R	Yes	NIPDAU	Level-2-260C-1 YEAR	-40 to 125	1PSP
TVS1401DRBR.A	Active	Production	SON (DRB) 8	3000 LARGE T&R	Yes	NIPDAU	Level-2-260C-1 YEAR	-40 to 125	1PSP

(1) **Status:** For more details on status, see our [product life cycle](#).

(2) **Material type:** When designated, preproduction parts are prototypes/experimental devices, and are not yet approved or released for full production. Testing and final process, including without limitation quality assurance, reliability performance testing, and/or process qualification, may not yet be complete, and this item is subject to further changes or possible discontinuation. If available for ordering, purchases will be subject to an additional waiver at checkout, and are intended for early internal evaluation purposes only. These items are sold without warranties of any kind.

(3) **RoHS values:** Yes, No, RoHS Exempt. See the [TI RoHS Statement](#) for additional information and value definition.

(4) **Lead finish/Ball material:** Parts may have multiple material finish options. Finish options are separated by a vertical ruled line. Lead finish/Ball material values may wrap to two lines if the finish value exceeds the maximum column width.

(5) **MSL rating/Peak reflow:** The moisture sensitivity level ratings and peak solder (reflow) temperatures. In the event that a part has multiple moisture sensitivity ratings, only the lowest level per JEDEC standards is shown. Refer to the shipping label for the actual reflow temperature that will be used to mount the part to the printed circuit board.

(6) **Part marking:** There may be an additional marking, which relates to the logo, the lot trace code information, or the environmental category of the part.

Multiple part markings will be inside parentheses. Only one part marking contained in parentheses and separated by a "~" will appear on a part. If a line is indented then it is a continuation of the previous line and the two combined represent the entire part marking for that device.

Important Information and Disclaimer:The information provided on this page represents TI's knowledge and belief as of the date that it is provided. TI bases its knowledge and belief on information provided by third parties, and makes no representation or warranty as to the accuracy of such information. Efforts are underway to better integrate information from third parties. TI has taken and continues to take reasonable steps to provide representative and accurate information but may not have conducted destructive testing or chemical analysis on incoming materials and chemicals. TI and TI suppliers consider certain information to be proprietary, and thus CAS numbers and other limited information may not be available for release.

In no event shall TI's liability arising out of such information exceed the total purchase price of the TI part(s) at issue in this document sold by TI to Customer on an annual basis.

TAPE AND REEL INFORMATION

QUADRANT ASSIGNMENTS FOR PIN 1 ORIENTATION IN TAPE

*All dimensions are nominal

Device	Package Type	Package Drawing	Pins	SPQ	Reel Diameter (mm)	Reel Width W1 (mm)	A0 (mm)	B0 (mm)	K0 (mm)	P1 (mm)	W (mm)	Pin1 Quadrant
TVS1401DRBR	SON	DRB	8	3000	330.0	12.4	3.3	3.3	1.1	8.0	12.0	Q2

TAPE AND REEL BOX DIMENSIONS

*All dimensions are nominal

Device	Package Type	Package Drawing	Pins	SPQ	Length (mm)	Width (mm)	Height (mm)
TVS1401DRBR	SON	DRB	8	3000	338.0	355.0	50.0

DRB 8

GENERIC PACKAGE VIEW

VSON - 1 mm max height

PLASTIC SMALL OUTLINE - NO LEAD



Images above are just a representation of the package family, actual package may vary.
Refer to the product data sheet for package details.

4203482/L

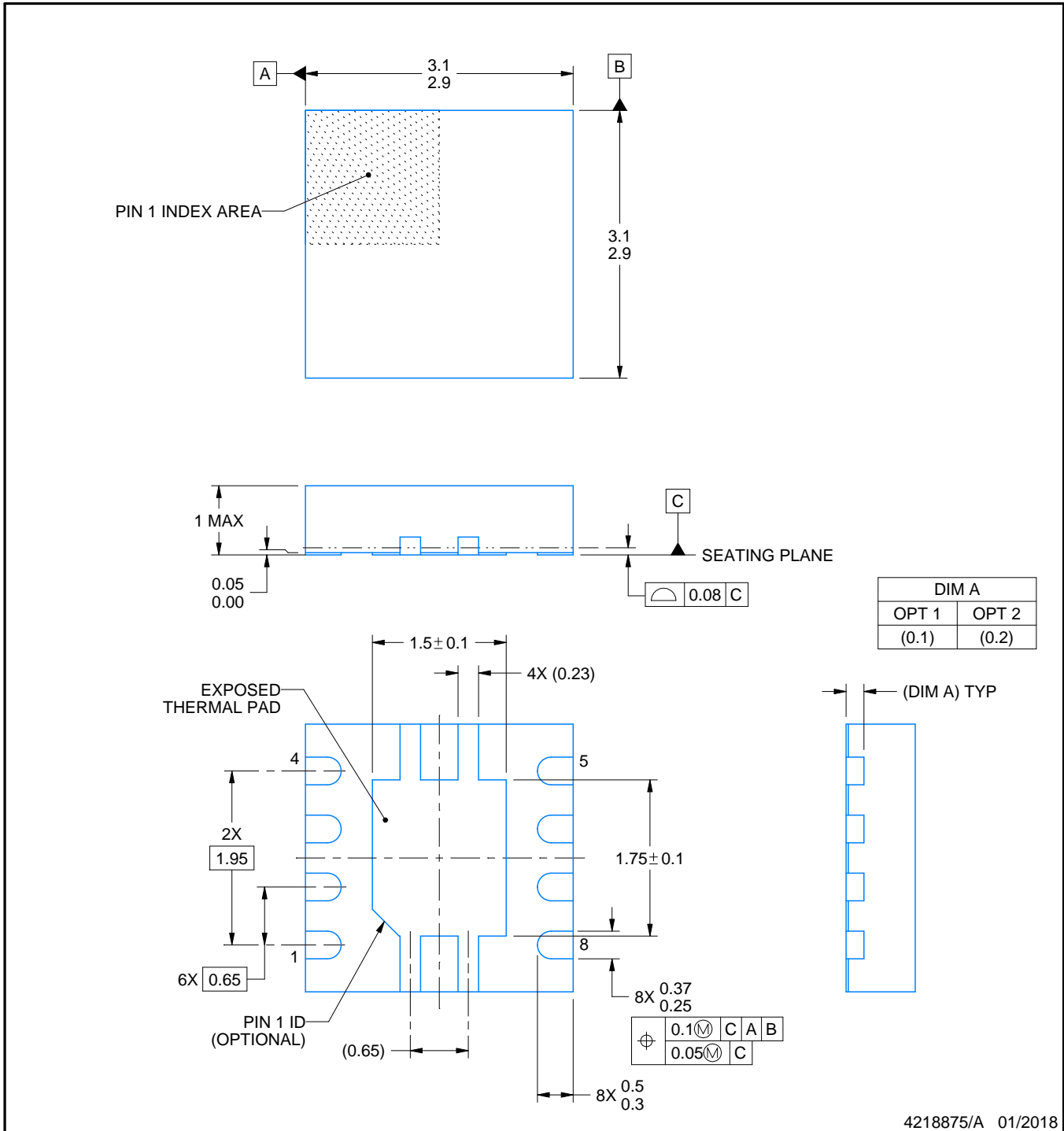

4218875/A 01/2018

NOTES:

1. All linear dimensions are in millimeters. Any dimensions in parenthesis are for reference only. Dimensioning and tolerancing per ASME Y14.5M.
2. This drawing is subject to change without notice.
3. The package thermal pad must be soldered to the printed circuit board for thermal and mechanical performance.

EXAMPLE BOARD LAYOUT

DRB0008A

VSON - 1 mm max height

PLASTIC SMALL OUTLINE - NO LEAD



LAND PATTERN EXAMPLE
EXPOSED METAL SHOWN
SCALE:20X



SOLDER MASK DETAILS

4218875/A 01/2018

NOTES: (continued)

4. This package is designed to be soldered to a thermal pad on the board. For more information, see Texas Instruments literature number SLUA271 (www.ti.com/lit/slua271).
5. Vias are optional depending on application, refer to device data sheet. If any vias are implemented, refer to their locations shown on this view. It is recommended that vias under paste be filled, plugged or tented.

EXAMPLE STENCIL DESIGN

DRB0008A

VSON - 1 mm max height

PLASTIC SMALL OUTLINE - NO LEAD

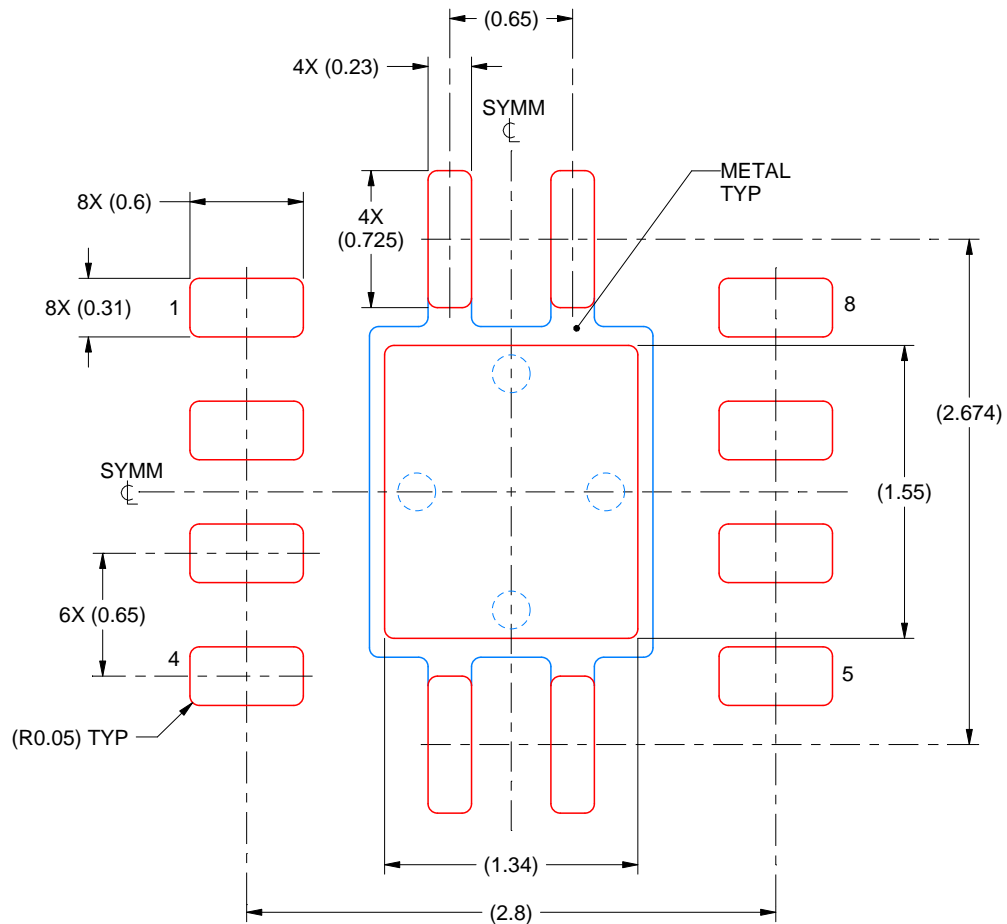

SOLDER PASTE EXAMPLE
BASED ON 0.125 mm THICK STENCIL

EXPOSED PAD
84% PRINTED SOLDER COVERAGE BY AREA
SCALE:25X

4218875/A 01/2018

NOTES: (continued)

6. Laser cutting apertures with trapezoidal walls and rounded corners may offer better paste release. IPC-7525 may have alternate design recommendations.

重要通知和免责声明

TI“按原样”提供技术和可靠性数据（包括数据表）、设计资源（包括参考设计）、应用或其他设计建议、网络工具、安全信息和其他资源，不保证没有瑕疵且不做任何明示或暗示的担保，包括但不限于对适销性、某特定用途方面的适用性或不侵犯任何第三方知识产权的暗示担保。

这些资源可供使用 TI 产品进行设计的熟练开发人员使用。您将自行承担以下全部责任：(1) 针对您的应用选择合适的 TI 产品，(2) 设计、验证并测试您的应用，(3) 确保您的应用满足相应标准以及任何其他功能安全、信息安全、监管或其他要求。

这些资源如有变更，恕不另行通知。TI 授权您仅可将这些资源用于研发本资源所述的 TI 产品的相关应用。严禁以其他方式对这些资源进行复制或展示。您无权使用任何其他 TI 知识产权或任何第三方知识产权。您应全额赔偿因在这些资源的使用中对 TI 及其代表造成的任何索赔、损害、成本、损失和债务，TI 对此概不负责。

TI 提供的产品受 [TI 的销售条款](#) 或 [ti.com](#) 上其他适用条款/TI 产品随附的其他适用条款的约束。TI 提供这些资源并不会扩展或以其他方式更改 TI 针对 TI 产品发布的适用的担保或担保免责声明。

TI 反对并拒绝您可能提出的任何其他或不同的条款。

邮寄地址：Texas Instruments, Post Office Box 655303, Dallas, Texas 75265
版权所有 © 2025，德州仪器 (TI) 公司