

TPS7B63xx-Q1

300mA、40V 高压超低静态电流看门狗 LDO

1 特性

- 符合面向汽车应用的 AEC-Q100 标准：
 - 温度等级 1: - 40 °C 至 125 °C、T_A
- 最大输出电流：300mA
- 4V 至 40V 宽 V_{IN} 输入电压范围，瞬态电压高达 45V
- 3.3V 和 5V 两种固定输出电压
- 最大压降电压：400mV/300mA
- 在宽电容 (4.7μF 至 500μF) 和 ESR (0.001Ω 至 20Ω) 范围内，与输出电容器搭配使用时可保持稳定
- 低静态电流 (I_Q)：
 - EN 为低电平 (关断模式) 时 < 4μA
 - 轻负载 (WD_EN 为高电平) 时具有 19μA 的典型值 (看门狗禁用)
- 可针对窗口看门狗和标准看门狗进行配置
- 开关窗口比例可配置为 1:1 或 8:1
- 完全可调的看门狗周期 (10ms 至 500ms)
- 看门狗周期精度为 10%
- 专用 WD_EN 引脚，用于控制看门狗开关
- 完全可调的电源正常阈值和电源正常延迟周期
- 针对 UVLO 的低输入电压跟踪功能
- 集成故障保护
 - 过载电流限制保护
 - 热关断
- 功能安全型
 - 可提供用于功能安全系统设计的文档
- 16 引脚 HTSSOP 封装

2 应用

- 汽车 MCU 电源
- 车身控制模块 (BCM)
- 座椅舒适模块
- EV 和 HEV 电池管理系统 (BMS)
- 电子换挡器
- 变速箱
- 电动助力转向 (EPS)

3 说明

在汽车微控制器或微处理器电源应用中，看门狗用于监测微控制器的工作状态，以防止软件失控。在可靠的系统中，看门狗必须独立于微控制器。

TPS7B63xx-Q1 是 300mA 看门狗低压降稳压器 (LDO) 系列器件，额定工作电压高达 40V，轻负载条件下的典型静态电流仅为 19μA。该系列器件集成了一项可编程功能，用于选择窗口看门狗或标准看门狗，并使用外部电阻设置看门狗时间，精度在 10% 以内。

TPS7B63xx-Q1 器件上的 PG 引脚指示输出电压何时达到稳定且处于稳压范围内。可以通过选择外部组件来调整电源正常延迟周期和电源正常阈值。该系列器件还具有集成的短路保护和过流保护功能。上述特性组合使得该系列器件极具灵活性，适用于为汽车应用中的微控制器供电。

器件信息

器件型号 (1)	输出电压	封装
TPS7B6333-Q1	固定 3.3V	HTSSOP (16)
TPS7B6350-Q1	固定 5V	

(1) 如需了解所有可用封装，请参阅数据表末尾的可订购产品附录。

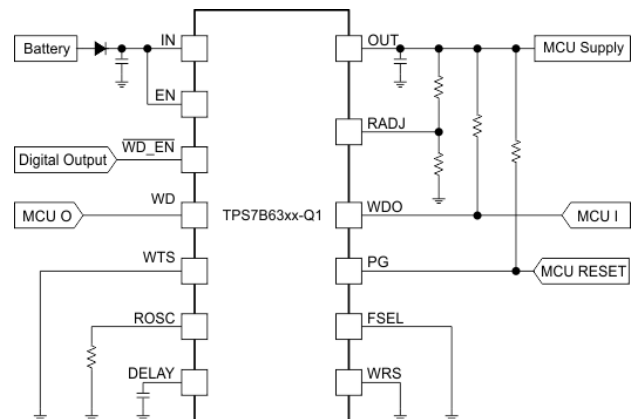

典型应用原理图



Table of Contents

1 特性	1	7.3 Feature Description.....	13
2 应用	1	7.4 Device Functional Modes.....	20
3 说明	1	8 Application and Implementation	21
4 Revision History	2	8.1 Application Information.....	21
5 Pin Configuration and Functions	3	8.2 Typical Application.....	21
6 Specifications	4	8.3 Power Supply Recommendations.....	23
6.1 Absolute Maximum Ratings.....	4	8.4 Layout.....	24
6.2 ESD Ratings.....	4	9 Device and Documentation Support	25
6.3 Recommended Operating Conditions.....	4	9.1 Documentation Support.....	25
6.4 Thermal Information.....	5	9.2 接收文档更新通知.....	25
6.5 Electrical Characteristics.....	5	9.3 支持资源.....	25
6.6 Switching Characteristics.....	8	9.4 Trademarks.....	25
6.7 Typical Characteristics.....	9	9.5 Electrostatic Discharge Caution.....	25
7 Detailed Description	13	9.6 术语表.....	25
7.1 Overview.....	13	10 Mechanical, Packaging, and Orderable Information	25
7.2 Functional Block Diagram.....	13		

4 Revision History

注：以前版本的页码可能与当前版本的页码不同

Changes from Revision B (September 2020) to Revision C (December 2022)	Page
• Changed PADJ and WTS pins to inputs instead of outputs.....	3
• Changed <i>Load Regulation</i> graph and changed VIN condition for I _{OUT} = 200 mA <i>Line Transient</i> graphs.....	9
• Changed resistor values in <i>TPS7B63xx-Q1 Typical Application Schematic</i> figure.....	21

Changes from Revision A (March 2017) to Revision B (September 2020)	Page
• 更新了整个文档中的表格、图和交叉参考的编号格式.....	1
• 更改了 <i>特性</i> 部分中的汽车特定应用要点.....	1
• 将 <i>特性</i> 部分的看门狗周期精度从 9% 更改为 10%.....	1
• 向 <i>特性</i> 部分添加了“功能安全型”要点.....	1
• 将 <i>说明</i> 部分的精度从 9% 更改为 10%.....	1
• Added ESD classification levels to <i>ESD Ratings</i> table.....	4
• Changed V _{OUT} parameter: added temperature range to test conditions of first parameter row and added second row to parameter.....	5
• Changed V _(dropout) maximum specification in second row of parameter from 260 mV to 325 mV.....	5
• Changed t _(DEGLITCH) minimum specification from 100 μs to 50 μs, changed t _(DLY_FIX) maximum specification from 550 μs to 900 μs, and deleted t _(DLY_FIX) minimum specification.....	8
• Changed fault 1 maximum open-window duration from t _(WD) / 2 to t _(WD)	19

5 Pin Configuration and Functions

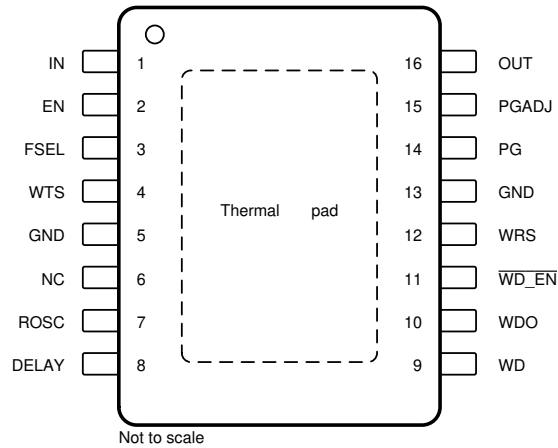

NC - No internal connection

图 5-1. PWP PowerPAD™ Package, 16-Pin HTSSOP With Exposed Thermal Pad (Top View)

表 5-1. Pin Functions

PIN		TYPE	DESCRIPTION
NAME	NO.		
DELAY	8	O	Power-good delay period adjustment pin. Connect this pin with a capacitor to ground to adjust the power-good delay time.
EN	2	I	Device enable pin. Pull this pin down to low-level voltage to disable the device. Pull this pin up to high-level voltage to enable the device.
FSEL	3	I	Internal oscillator frequency selection pin. Pull this pin down to low-level voltage to select the high-frequency oscillator. Pull this pin up to high-level voltage to select the low-frequency oscillator.
GND	5, 13	—	Ground reference
IN	1	I	Device input power-supply pin
NC	6	—	Not connected
OUT	16	O	Device 3.3-V or 5-V regulated output voltage pin
PG	14	O	Power-good pin. Open-drain output pin. Pull this pin up to V_{OUT} or to a reference through a resistor. When the output voltage is not ready, this pin is pulled down to ground.
PGADJ	15	I	Power-good threshold adjustment pin. Connect a resistor divider between the PGADJ and OUT pins to set the power-good threshold. Connect this pin to ground to set the threshold to 91.6% of output voltage V_{OUT} .
ROSC	7	O	Watchdog timer adjustment pin. Connect a resistor between the ROSC pin and the GND pin to set the duration of the watchdog monitor. Leaving this pin open or connecting this pin to ground results in the watchdog reporting a fault at the watchdog output (WDO).
WD	9	I	Watchdog service-signal input pin.
WDO	10	O	Watchdog status pin. Open-drain output pin. Pull this pin up to OUT or a reference voltage through a resistor. When watchdog fault occurs, this pin is pulled down to a low-level voltage.
WD_EN	11	I	Watchdog enable pin. Pull this pin down to a low level to enable the watchdog. Pull this pin up to a high level to disable the watchdog.
WRS	12	I	Window ratio selection pin (only applicable for the window watchdog). Pull this pin down to a low level to set the open:closed window ratio to 1:1. Pull this pin up to high level to set the open:closed window ratio to 8:1.
WTS	4	I	Watchdog type-selection pin. To set the window watchdog, connect this pin to the GND pin. To set the standard watchdog, pull this pin high.
Thermal pad	—	—	Solder to board to improve the thermal performance.

6 Specifications

6.1 Absolute Maximum Ratings

over operating ambient temperature range (unless otherwise noted)^{(1) (2)}

		MIN	MAX	UNIT
Unregulated input	IN, EN	- 0.3	45	V
Internal oscillator reference voltage	ROSC	- 0.3	7	V
Power-good delay-timer output	DELAY	- 0.3	7	V
Regulated output	OUT	- 0.3	7	V
Power-good output voltage	PG	- 0.3	7	V
Watchdog status output voltage	WDO	- 0.3	7	V
Watchdog frequency selection, watchdog-type selection	FSEL, WTS	- 0.3	45	V
Watchdog enable	WD_EN	- 0.3	7	V
Watchdog service signal voltage	WD	- 0.3	7	V
Window ratio selection	WRS	- 0.3	7	V
Power-good threshold-adjustment voltage	PGADJ	- 0.3	7	V
Operating junction temperature, T _J		- 40	150	°C
Storage temperature, T _{stg}		- 65	150	°C

- (1) Stresses beyond those listed under *Absolute Maximum Ratings* may cause permanent damage to the device. These are stress ratings only, which do not imply functional operation of the device at these or any other conditions beyond those indicated under *Recommended Operating Conditions*. Exposure to absolute-maximum-rated conditions for extended periods may affect device reliability.
- (2) All voltage values are with respect to ground.

6.2 ESD Ratings

		VALUE	UNIT	
V _(ESD)	Electrostatic discharge	Human-body model (HBM), per AEC Q100-002 ⁽¹⁾ , device HBM ESD classification level 2	±2000	
		Charged-device model (CDM), per AEC Q100-011, device CDM ESD classification level C4B	All pins	±500
			Corner pins (1, 14, 15, and 28)	±750

- (1) AEC Q100-002 indicates that HBM stressing shall be in accordance with the ANSI/ESDA/JEDEC JS-001 specification.

6.3 Recommended Operating Conditions

Over operating ambient temperature range (unless otherwise noted)

		MIN	MAX	UNIT
Unregulated input	IN	4	40	V
40-V pins	EN, FSEL, WTS	0	V _{IN}	V
Regulated output	OUT	0	5.5	V
Power good, watchdog status, reference oscillator	PG, WDO, ROSC	0	5.5	V
Low voltage pins	WD, WD_EN, PGADJ, DELAY, WRS	0	5.5	V
Output current		0	300	mA
Ambient temperature, T _A		- 40	125	°C

6.4 Thermal Information

THERMAL METRIC ⁽¹⁾		TPS7B63xx-Q1	UNIT
		PWP (HTSSOP)	
		16 PINS	
$R_{\theta JA}$	Junction-to-ambient thermal resistance	39.7	°C/W
$R_{\theta JC(top)}$	Junction-to-case (top) thermal resistance	28.9	°C/W
$R_{\theta JB}$	Junction-to-board thermal resistance	23.8	°C/W
ψ_{JT}	Junction-to-top characterization parameter	1.3	°C/W
ψ_{JB}	Junction-to-board characterization parameter	23.7	°C/W
$R_{\theta JC(bot)}$	Junction-to-case (bottom) thermal resistance	3.1	°C/W

(1) For more information about traditional and new thermal metrics, see the [Semiconductor and IC Package Thermal Metrics application report](#).

6.5 Electrical Characteristics

$V_{IN} = 14\text{ V}$, $C_{OUT} \geq 4.7\ \mu\text{F}$, $1\ \text{m}\Omega < \text{ESR} < 20\ \Omega$, and $T_J = -40^\circ\text{C}$ to 150°C (unless otherwise noted)

PARAMETER		TEST CONDITIONS	MIN	TYP	MAX	UNIT
SUPPLY VOLTAGE AND CURRENT (IN)						
V_{IN}	Input voltage		4		40	V
$I_{(SLEEP)}$	Input sleep current	EN = OFF			4	μA
$I_{(Q)}$	Input quiescent current	$V_{IN} = 5.6\text{ V to }40\text{ V}$ for fixed 5-V V_{OUT} ; $V_{IN} = 4\text{ V to }40\text{ V}$ for fixed 3.3-V V_{OUT} ; EN = ON; watchdog disabled; $I_{OUT} < 1\ \text{mA}$; $T_J < 80^\circ\text{C}$		19	29.6	μA
		$V_{IN} = 5.6\text{ V to }40\text{ V}$ for fixed 5-V V_{OUT} ; $V_{IN} = 4\text{ V to }40\text{ V}$ for fixed 3.3-V V_{OUT} ; EN = ON; watchdog enabled; $I_{OUT} < 1\ \text{mA}$		28	42	
		$V_{IN} = 5.6\text{ V to }40\text{ V}$ for fixed 5-V V_{OUT} ; $V_{IN} = 4\text{ V to }40\text{ V}$ for fixed 3.3-V V_{OUT} ; EN = ON; watchdog enabled; $I_{OUT} < 100\ \text{mA}$		78	98	
$V_{(UVLO)}$	Undervoltage lockout, falling	Ramp V_{IN} down until output is turned off			2.6	V
$V_{(UVLO_HYST)}$	UVLO hysteresis			0.5		V
ENABLE INPUT, WATCHDOG TYPE SELECTION AND FSEL (EN, WTS, AND FSEL)						
V_{IL}	Low-level input voltage				0.7	V
V_{IH}	High-level input voltage		2			V
V_{hys}	Hysteresis			150		mV
WATCHDOG ENABLE (WD_EN PIN)						
V_{IL}	Low-level input threshold voltage for watchdog enable pin	Watchdog enabled			0.7	V
V_{IH}	High-level input threshold voltage for watchdog enable pin	Watchdog disabled	2			V
I_{WD_EN}	Pulldown current for watchdog enable pin	$V_{WD_EN} = 5\ \text{V}$			3	μA
REGULATED OUTPUT (OUT)						
V_{OUT}	Regulated output	$V_{IN} = 5.6\text{ V to }40\text{ V}$ for fixed 5-V V_{OUT} ; $V_{IN} = 4\text{ V to }40\text{ V}$ for fixed 3.3-V V_{OUT} ; $I_{OUT} = 0\text{ to }300\ \text{mA}$, $-40^\circ\text{C} \leq T_J \leq 125^\circ\text{C}$	- 2%		2%	
		$V_{IN} = 5.6\text{ V to }40\text{ V}$ for fixed 5-V V_{OUT} ; $V_{IN} = 4\text{ V to }40\text{ V}$ for fixed 3.3-V V_{OUT} ; $I_{OUT} = 0\text{ to }300\ \text{mA}$	- 2.5%		2.5%	
$\Delta V_{OUT(\Delta V_{IN})}$	Line regulation	$V_{IN} = 5.6\text{ V to }40\text{ V}$			10	mV

6.5 Electrical Characteristics (continued)

 $V_{IN} = 14\text{ V}$, $C_{OUT} \geq 4.7\ \mu\text{F}$, $1\ \text{m}\Omega < \text{ESR} < 20\ \Omega$, and $T_J = -40^\circ\text{C}$ to 150°C (unless otherwise noted)

PARAMETER		TEST CONDITIONS	MIN	TYP	MAX	UNIT
$\Delta V_{OUT(\Delta I_{OUT})}$	Load regulation	$I_{OUT} = 1\ \text{mA}$ to $300\ \text{mA}$			20	mV
$V_{(\text{dropout})}$	Dropout voltage ($V_{IN} - V_{OUT}$)	$I_{OUT} = 300\ \text{mA}^{(2)}$		300	400	mV
		$I_{OUT} = 200\ \text{mA}^{(2)}$		170	325	
I_{OUT}	Output current	V_{OUT} in regulation	0		300	mA
$I_{(\text{LIM})}$	Output current limit	V_{OUT} shorted to ground, $V_{IN} = 5.6\ \text{V}$ to $40\ \text{V}$	301	680	1000	mA
PSRR	Power-supply ripple rejection ⁽¹⁾	$I_{OUT} = 100\ \text{mA}$; $C_{OUT} = 10\ \mu\text{F}$; frequency (f) = 100 Hz		60		dB
		$I_{OUT} = 100\ \text{mA}$; $C_{OUT} = 10\ \mu\text{F}$; frequency (f) = 100 kHz		40		
POWER-GOOD (PG, PGADJ)						
$V_{OL(\text{PG})}$	PG output, low voltage	$I_{OL} = 5\ \text{mA}$, PG pulled low			0.4	V
$I_{\text{kg}(\text{PG})}$	PG pin leakage current	PG pulled to V_{OUT} through a $10\text{-k}\ \Omega$ resistor			1	μA
$V_{(\text{PG_TH})}$	Default power-good threshold	V_{OUT} powered above the internally set tolerance, PGADJ pin shorted to ground	89.6	91.6	93.6	% of V_{OUT}
$V_{(\text{PG_HYST})}$	Power-good hysteresis	V_{OUT} falling below the internally set tolerance hysteresis		2		% of V_{OUT}
PGADJ						
$V_{(\text{PGADJ_TH})}$	Switching voltage for the power-good adjust pin	V_{OUT} is falling	1.067	1.1	1.133	V
POWER-GOOD DELAY						
$I_{(\text{DLY_CHG})}$	DELAY capacitor charging current		3	5	10	μA
$V_{(\text{DLY_TH})}$	DELAY pin threshold to release PG high	Voltage at DELAY pin is ramped up	0.95	1	1.05	V
$I_{(\text{DLY_DIS})}$	DELAY capacitor discharging current	$V_{\text{DELAY}} = 1\ \text{V}$	0.5			mA
CURRENT VOLTAGE REFERENCE (ROSC)						
V_{ROSC}	Voltage reference		0.95	1	1.05	V
WATCHDOG (WD, WDO, WRS)						
V_{IL}	Low-level threshold voltage for the watchdog input and window-ratio select	For WD and WRS pins			30	% of V_{OUT}
V_{IH}	High-level threshold voltage for the watchdog input and window-ratio select	For WD and WRS pins	70			% of V_{OUT}
$V_{(\text{HYST})}$	Hysteresis			10		% of V_{OUT}
I_{WD}	Pulldown current for the WD pin	$V_{\text{WDO}} = 5\ \text{V}$		2	4	μA
V_{OL}	Low-level watchdog output	$I_{\text{WDO}} = 5\ \text{mA}$			0.4	V
I_{kg}	WDO pin leakage current	WDO pin pulled to V_{OUT} through $10\text{-k}\ \Omega$ resistor			1	μA
OPERATING TEMPERATURE RANGE						
T_J	Junction temperature		-40		150	$^\circ\text{C}$
$T_{(\text{SD})}$	Junction shutdown temperature			175		$^\circ\text{C}$
$T_{(\text{HYST})}$	Hysteresis of thermal shutdown			25		$^\circ\text{C}$

(1) Design information - not tested, determined by characterization.

- (2) This test is done with V_{OUT} in regulation, measuring the $V_{IN} - V_{OUT}$ when V_{OUT} drops by 100 mV from the rated output voltage at the specified load.

6.6 Switching Characteristics

$V_I = 14\text{ V}$, $C_O \geq 4.7\ \mu\text{F}$, $1\ \text{m}\Omega < \text{ESR} < 20\ \Omega$, and $T_J = -40^\circ\text{C}$ to 150°C (unless otherwise noted)

PARAMETER		TEST CONDITIONS	MIN	TYP	MAX	UNIT
POWER-GOOD DELAY (DELAY)						
$t_{(\text{DEGLITCH})}$	Power-good deglitch time		50	180	250	μs
$t_{(\text{DLY_FIX})}$	Fixed power-good delay	No capacitor connect at DELAY pin		248	900	μs
$t_{(\text{DLY})}$	Power-on-reset delay	Delay capacitor value: $C_{(\text{DELAY})} = 100\ \text{nF}$		20		ms
WATCHDOG (WD, WDO, WRS)						
$t_{(\text{WD})}$	Watchdog window duration	$R_{(\text{ROSC})} = 20\ \text{k}\Omega \pm 1\%$, FSEL = LOW	9	10	11	ms
		$R_{(\text{ROSC})} = 20\ \text{k}\Omega \pm 1\%$, FSEL = HIGH	45	50	55	
$t_{(\text{WD_TOL})}$	Tolerance of watchdog window duration using external resistor	Excludes tolerance of $R_{(\text{ROSC})} = 20\ \text{k}\Omega$ to $100\ \text{k}\Omega$	- 10%		10%	
$t_{\text{p}(\text{WD})}$	Watchdog service-signal duration		100			μs
$t_{(\text{WD_HOLD})}$	Watchdog output resetting time (percentage of settled watchdog window duration)			20		% of $t_{(\text{WD})}$
$t_{(\text{WD_RESET})}$	Watchdog output resetting time	$R_{(\text{ROSC})} = 20\ \text{k}\Omega \pm 1\%$, FSEL = LOW	1.8	2	2.2	ms
		$R_{(\text{ROSC})} = 20\ \text{k}\Omega \pm 1\%$, FSEL = HIGH	9	10	11	

6.7 Typical Characteristics

at $V_{IN} = 14\text{ V}$, $V_{EN} \geq 2\text{ V}$, and $T_J = -40^\circ\text{C}$ to $+150^\circ\text{C}$ (unless otherwise noted)



图 6-1. Quiescent Current vs Output Current



图 6-2. Quiescent Current vs Input Voltage

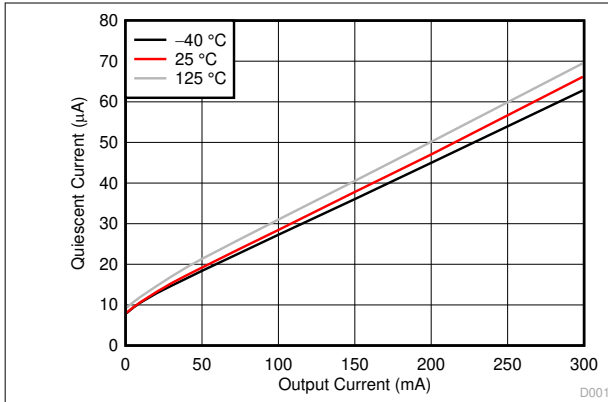

图 6-3. Shutdown Current vs Ambient Temperature

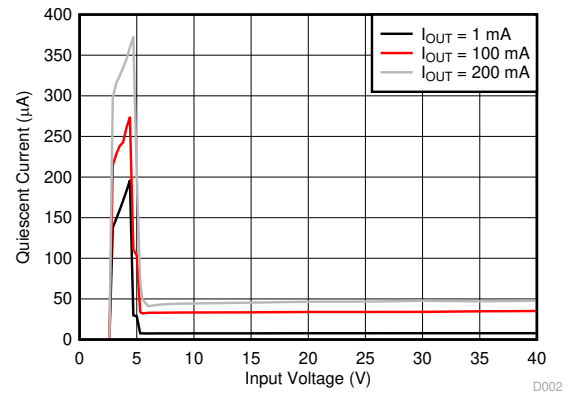

图 6-4. Quiescent Current vs Ambient Temperature

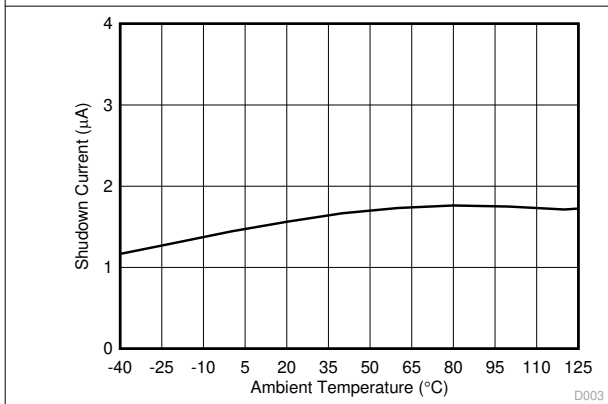

图 6-5. Dropout Voltage vs Output Current

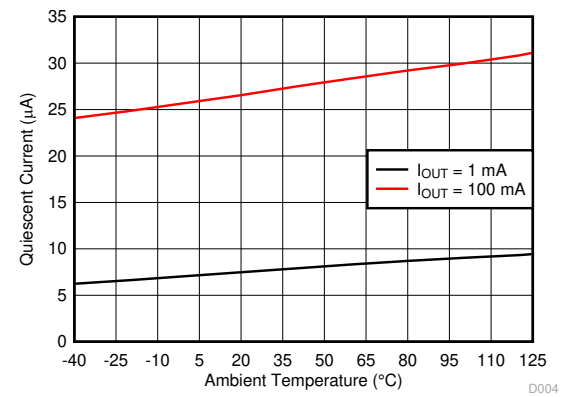

图 6-6. Dropout Voltage vs Ambient Temperature

6.7 Typical Characteristics (continued)

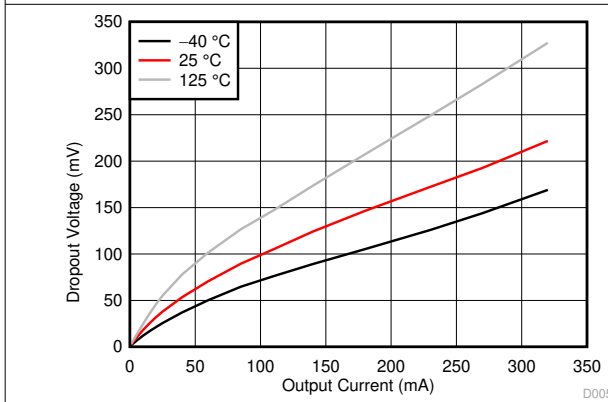
at $V_{IN} = 14\text{ V}$, $V_{EN} \geq 2\text{ V}$, and $T_J = -40^\circ\text{C}$ to $+150^\circ\text{C}$ (unless otherwise noted)

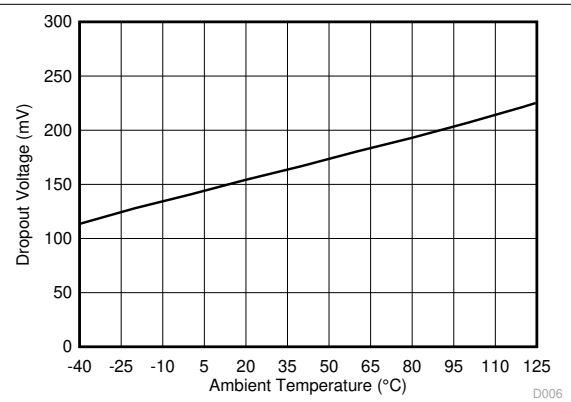

图 6-7. Output Voltage vs Ambient Temperature



图 6-8. Output Voltage vs Input Voltage

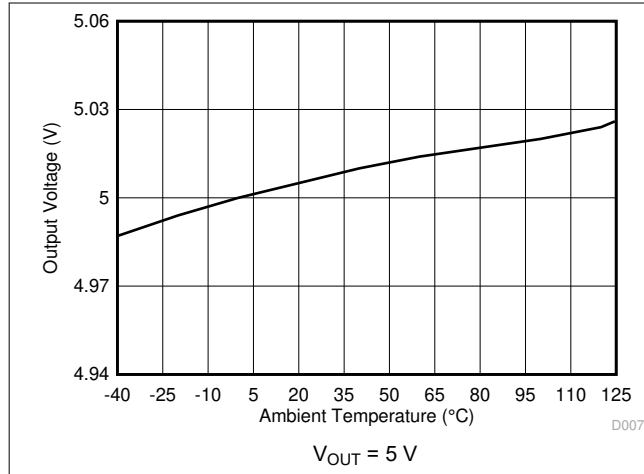

图 6-9. Output Current Limit (I_{LIM}) vs Ambient Temperature

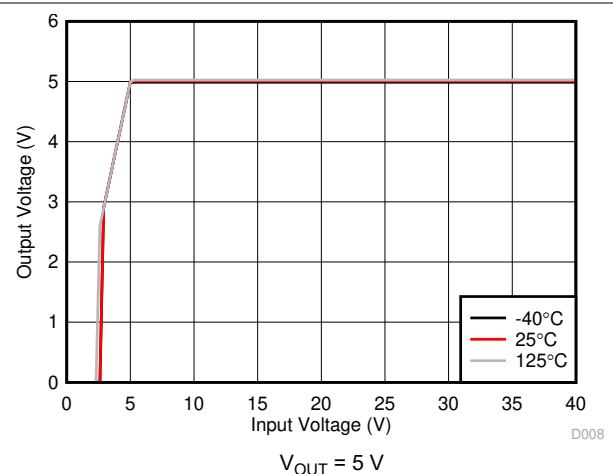

图 6-10. Load Regulation

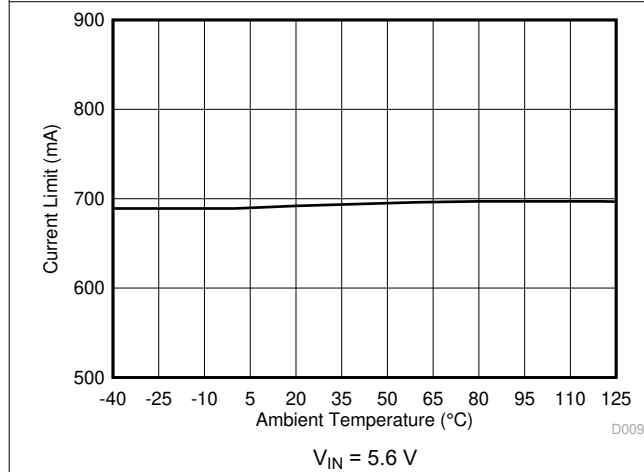

图 6-11. Line Regulation

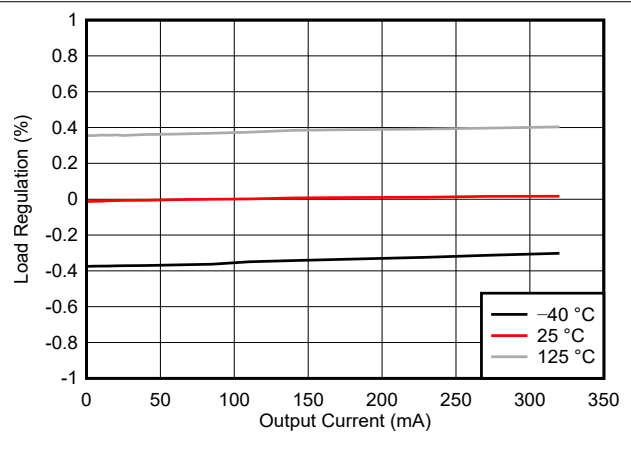

图 6-12. PSRR vs Frequency

6.7 Typical Characteristics (continued)

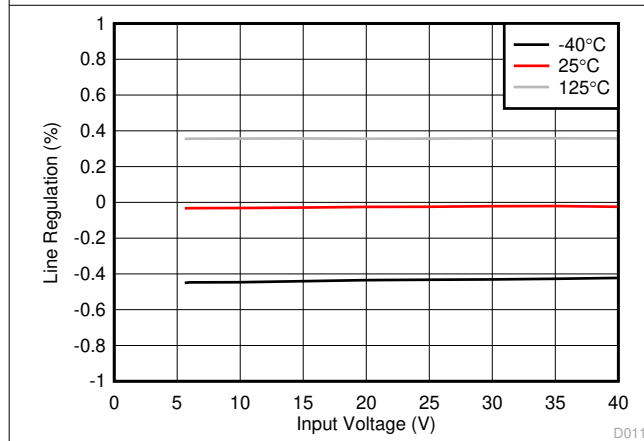
at $V_{IN} = 14\text{ V}$, $V_{EN} \geq 2\text{ V}$, and $T_J = -40^\circ\text{C}$ to $+150^\circ\text{C}$ (unless otherwise noted)

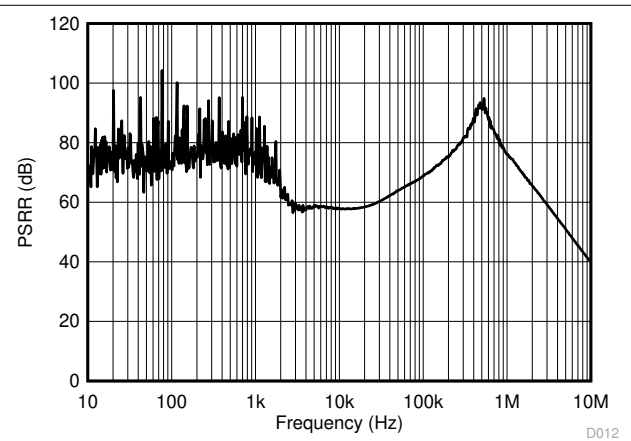

图 6-13. PSRR vs Frequency



图 6-14. ESR Stability vs Output Capacitance

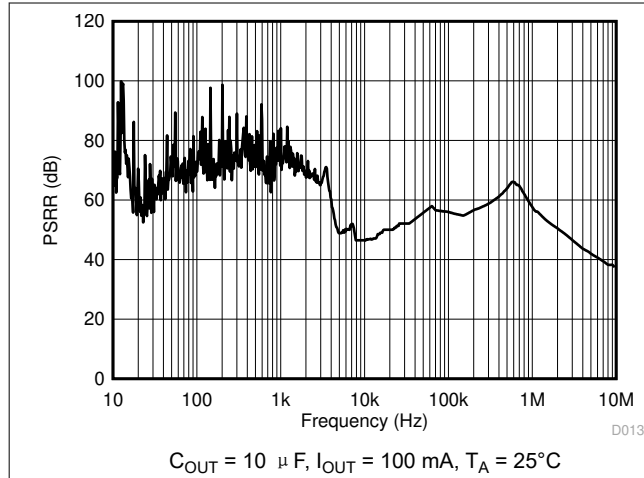

图 6-15. Line Transient

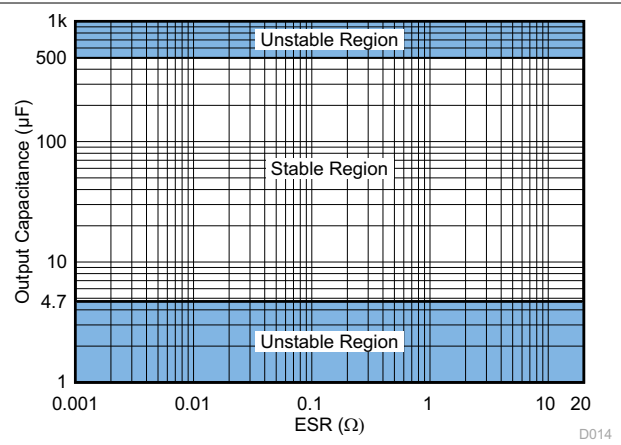

图 6-16. Line Transient

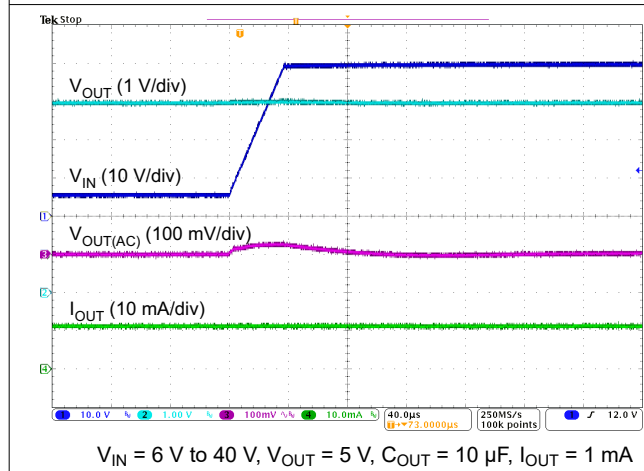

图 6-17. Line Transient

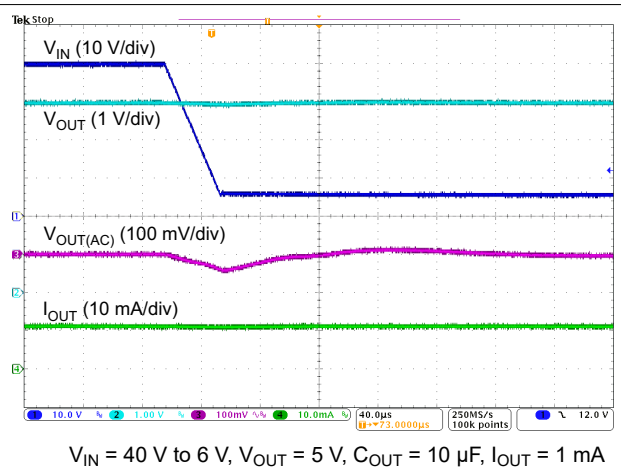

图 6-18. Line Transient

6.7 Typical Characteristics (continued)

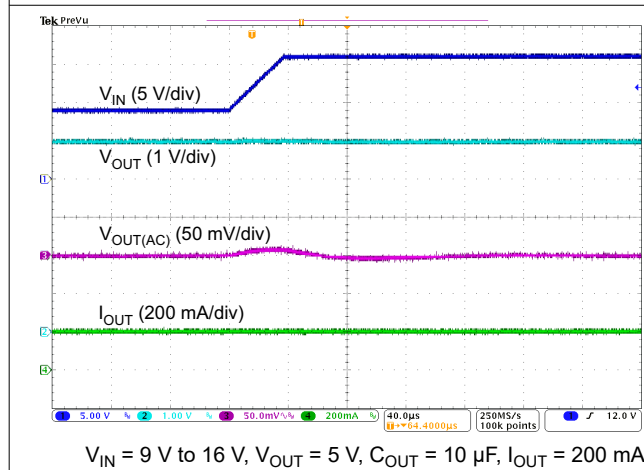
at $V_{IN} = 14\text{ V}$, $V_{EN} \geq 2\text{ V}$, and $T_J = -40^\circ\text{C}$ to $+150^\circ\text{C}$ (unless otherwise noted)

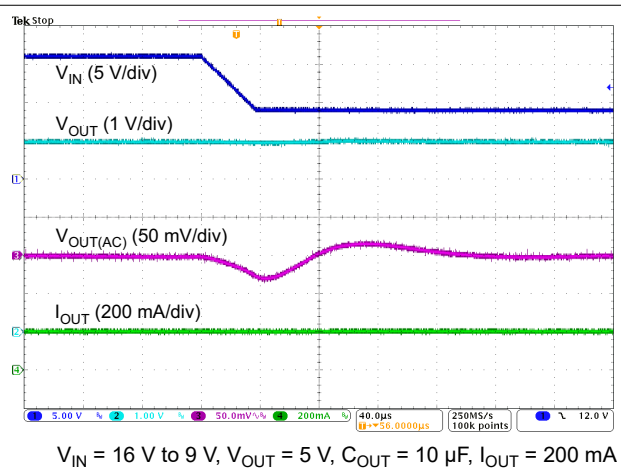
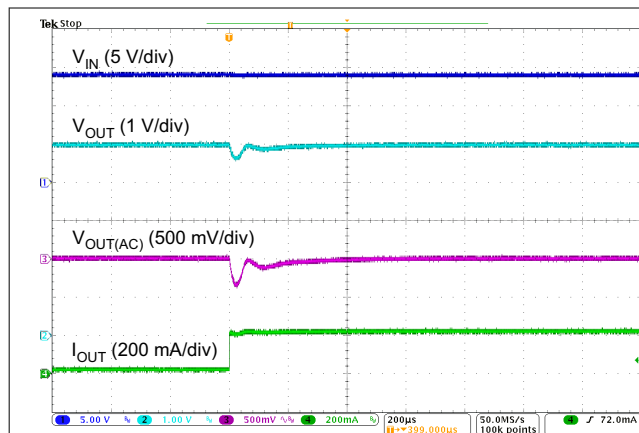

$V_{OUT} = 5\text{ V}$, $C_{OUT} = 10\text{ }\mu\text{F}$, $I_{OUT} = 1\text{ mA}$ to 200 mA

图 6-19. Load Transient

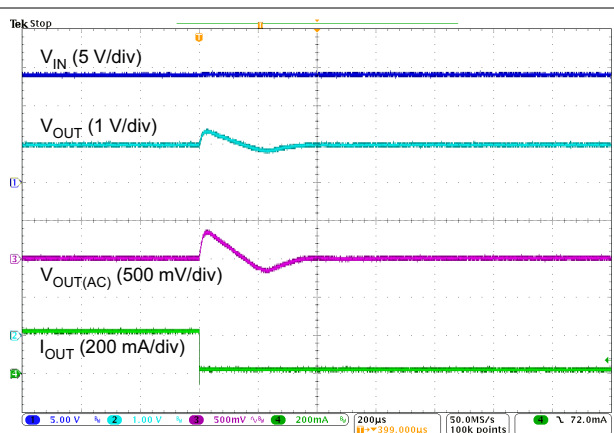

$V_{OUT} = 5\text{ V}$, $C_{OUT} = 10\text{ }\mu\text{F}$, $I_{OUT} = 200\text{ mA}$ to 1 mA

图 6-20. Load Transient

7 Detailed Description

7.1 Overview

The TPS7B63xx-Q1 device is a family of 300-mA, 40-V monolithic low-dropout linear voltage regulators with integrated watchdog and adjustable power-good threshold functionality. These voltage regulators consume only 19- μ A quiescent current in light-load applications. Because of the adjustable power-good delay (also called power-on-reset delay) and the adjustable power-good threshold, these devices are well-suited as power supplies for microprocessors and microcontrollers in automotive applications.

7.2 Functional Block Diagram

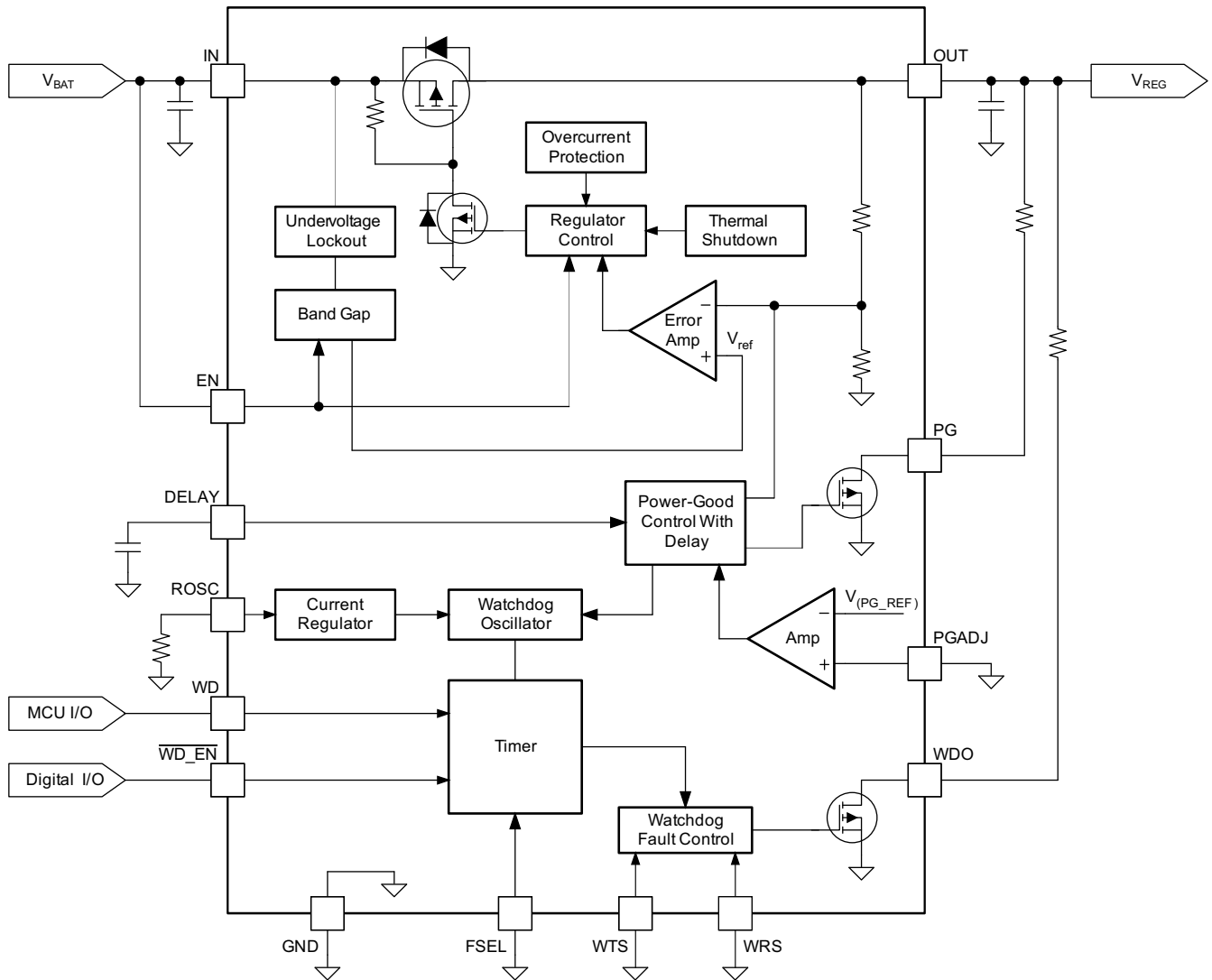

7.3 Feature Description

7.3.1 Device Enable (EN)

The EN pin is a high-voltage-tolerant pin. A high input activates the device and turns the regulator ON. Connect this input pin to an external microcontroller or a digital control circuit to enable and disable the device, or connect to the IN pin for self-bias applications.

7.3.2 Adjustable Power-Good Threshold (PG, PGADJ)

The PG pin is an open-drain output with an external pullup resistor to the regulated supply, and the PGADJ pin is a power-good threshold adjustment pin. Connecting the PGADJ pin to GND sets the power-good threshold value to the default, $V_{(PG_TH)}$. When V_{OUT} exceeds the default power-good threshold, the PG output turns high after the power-good delay period has expired. When V_{OUT} falls below $V_{(PG_TH)} - V_{(PG_HYST)}$, the PG output turns low after a short deglitch time.

The power-good threshold is also adjustable from 1.1 V to 5 V by using an external resistor divider between PGADJ and OUT. The threshold can be calculated using [方程式 1](#):

$$V_{(PG_ADJ) \text{ falling}} = V_{(PGADJ_TH) \text{ falling}} \times \frac{R1 + R2}{R2}$$

$$V_{(PG_ADJ) \text{ rising}} = \left[V_{(PGADJ_TH) \text{ falling}} + 26 \text{ mV (typ)} \right] \times \frac{R1 + R2}{R2} \quad (1)$$

where

- $V_{(PG_ADJ)}$ is the adjustable power-good threshold
- $V_{(PG_REF)}$ is the internal comparator reference voltage of the PGADJ pin, 1.1 V typical, 2% accuracy specified under all conditions

By setting the power-good threshold $V_{(PG_ADJ)}$, when V_{OUT} exceeds this threshold, the PG output turns high after the power-good delay period has expired. When V_{OUT} falls below $V_{(PG_ADJ)} - V_{(PG_HYST)}$, the PG output turns low after a short deglitch time. [图 7-1](#) shows typical hardware connections for the PGADJ pin and DELAY pin.



图 7-1. Adjustable Power-Good Threshold

7.3.3 Adjustable Power-Good Delay Timer (DELAY)

The power-good delay period is a function of the value set by an external capacitor on the DELAY pin before turning the PG pin high. 图 7-2 illustrates typical power-good and delay behavior. Connecting an external capacitor from this pin to GND sets the power-good delay period. The constant current charges an external capacitor until the voltage exceeds a threshold to trip an internal comparator, and 方程式 2 determines the power-good delay period:

$$t_{(DLY)} = t_{dly_fix} + \frac{C_{DELAY} \times 1V}{5 \mu A} \quad (2)$$

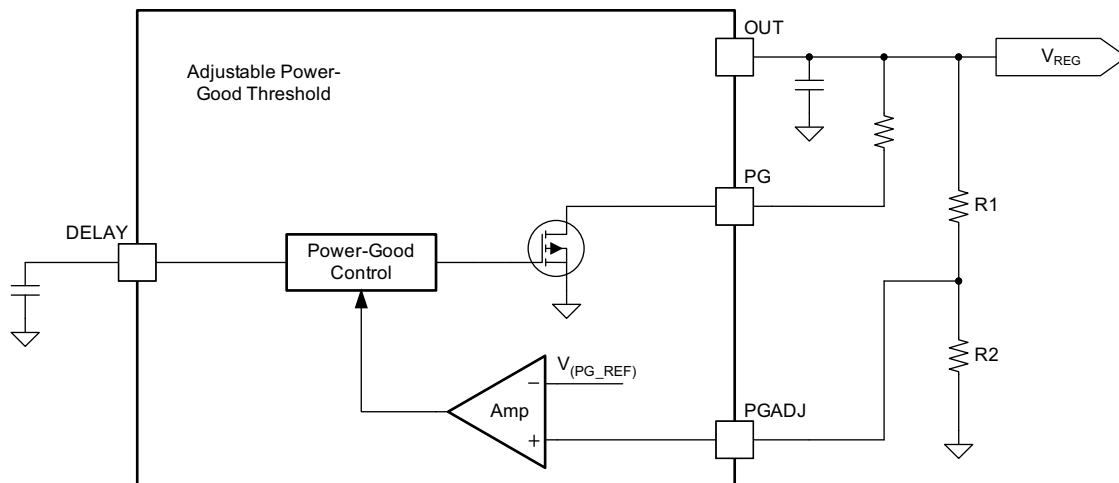
where

- $t_{(DLY)}$ is the adjustable power-good delay period
- C_{DELAY} is the value of the power-good delay capacitor



图 7-2. Power Up and Conditions for Activating Power-Good

If the DELAY pin is open, the default delay time is $t_{(DLY_FIX)}$.

7.3.4 Undervoltage Shutdown

These devices have an integrated undervoltage lockout (UVLO) circuit to shut down the output if the input voltage falls below an internal UVLO threshold, $V_{(UVLO)}$. This ensures that the regulator does not latch into an unknown state during low-input-voltage conditions. If the input voltage has a negative transient which drops below the UVLO threshold and recovers, the regulator shuts down and powers up with a normal power-up sequence once the input voltage is above the required level.

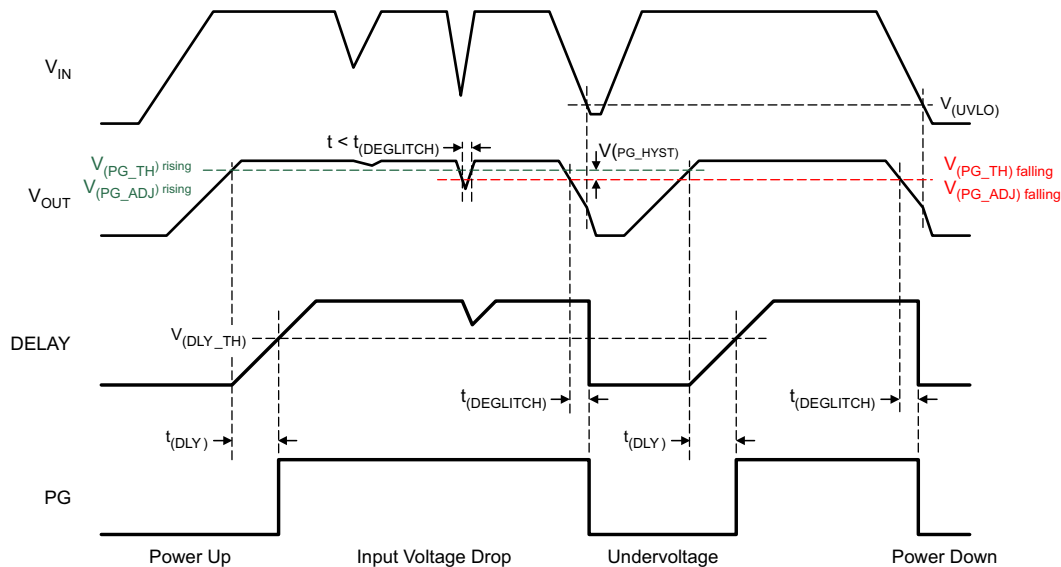
7.3.5 Current Limit

These devices feature current-limit protection to keep the device in a safe operating area when an overload or output short-to-ground condition occurs. This protects devices from excessive power dissipation. For example, during a short-circuit condition on the output, fault protection limits the current through the pass element to $I_{(LIM)}$ to protect the device from excessive power dissipation.

7.3.6 Thermal Shutdown

These devices incorporate a thermal shutdown (TSD) circuit as a protection from overheating. For continuous normal operation, the junction temperature should not exceed the TSD trip point. The junction temperature

exceeding the TSD trip point causes the output to turn off. When the junction temperature falls below the $T_{(SD)} - T_{(HYST)}$, the output turns on again.

7.3.7 Integrated Watchdog

These devices have an integrated watchdog with fault (WDO) output option. Both window watchdog and standard watchdog are available in one device. The watchdog operation, service fault conditions, and differences between window watchdog and standard watchdog are described as follows.

7.3.7.1 Window Watchdog (WTS, ROOSC, FSEL and WRS)

These devices work in the window watchdog mode when the watchdog type selection (WTS) pin is connected to a low voltage level. The user can set the duration of the watchdog window by connecting an external resistor (R_{ROSC}) to ground at the ROOSC pin and setting the voltage level at the FSEL pin. The current through the R_{ROSC} resistor sets the clock frequency of the internal oscillator. The user can adjust the duration of the watchdog window (the watchdog timer period) by changing the resistor value. A high voltage level at the FSEL pin sets the watchdog window duration to 5 times as long as that of a low voltage level with same external component configuration.

The duration of the watchdog window and the duration of the fault output are multiples of the internal oscillator frequency, as shown by the following equations:

$$\text{FSEL low} \quad t_{(WD)} = R_{ROSC} \times 0.5 \times 10^{-6} \quad (3)$$

$$\text{FSEL high} \quad t_{(WD)} = R_{ROSC} \times 2.5 \times 10^{-6} \quad (4)$$

$$\text{Watchdog initialization} \quad t_{(WD_INI)} = 8 \times t_{(WD)} \quad (5)$$

$$\text{Open and closed windows} \quad t_{(WD)} = t_{(OW)} + t_{(CW)} \quad (6)$$

$$\text{WRS low} \quad t_{(OW)} = t_{(CW)} = 50\% \times t_{(WD)} \quad (7)$$

$$\text{WRS high} \quad t_{(OW)} = 8 \times t_{(CW)} = (8 / 9) \times t_{(WD)} \quad (8)$$

where:

- $t_{(WD)}$ is the duration of the watchdog window
- R_{ROSC} is the resistor connected at the ROOSC pin
- $t_{(WD_INI)}$ is the duration of the watchdog initialization
- $t_{(OW)}$ is the duration of the open watchdog window
- $t_{(CW)}$ is the duration of the closed watchdog window

For all the foregoing items, the unit of resistance is Ω and the unit of time is s.

表 7-1 illustrates several periods of watchdog window with typical conditions.

表 7-1. Several Typical Periods of Watchdog Window

FSEL	$R_{(ROSC)}$ (k Ω)	$I_{(ROSC)}$ (μ A)	$t_{(WD)}$ (ms)	WATCHDOG PERIOD TOLERANCE
High	200	5	500	15%
	100	10	250	10%
	50	20	125	
	40	25	100	
	25	40	62.5	
	20	50	50	
Low	100	10	50	10%
	50	20	25	
	40	25	20	
	25	40	12.5	
	20	50	10	

As illustrated in 图 7-3, each watchdog window consists of an open window and a closed window. While the window ratio selection (WRS) pin is low, each open window ($t_{(OW)}$) and closed window ($t_{(CW)}$) has a width approximately 50% of the watchdog window ($t_{(WD)}$). While the WRS pin is high, the ratio between open window and closed window is about 8:1. However, there is an exception to this; the first open window after watchdog initialization ($t_{(WD_INI)}$) is eight times the duration of the watchdog window. The watchdog must receive the service signal (by software, external microcontroller, and so forth) during this initialization open window.

A watchdog fault occurs when servicing the watchdog during a closed window, or not servicing during an open window.



图 7-3. Watchdog Initialization, Open Window and Closed Window

7.3.7.2 Standard Watchdog (WTS, ROSC and FSEL)

These devices work in the standard watchdog mode when the watchdog type selection (WTS) pin is connected to a high voltage level. The same as in window watchdog mode, the user can set the duration of the watchdog window by adjusting the external resistor (R_{ROSC}) value at the ROSC pin and setting the voltage level at the FSEL pin. The current through the R_{ROSC} resistor sets the clock frequency of the internal oscillator. The user can adjust the duration of the watchdog window (the watchdog timer period) by changing the resistor value. A high voltage level at the FSEL pin sets the watchdog window duration to 5 times as long as that of a low voltage level with same external component configuration.

The duration of the watchdog window and the duration of the fault output are multiples of the internal oscillator frequency, as shown by the following equations:

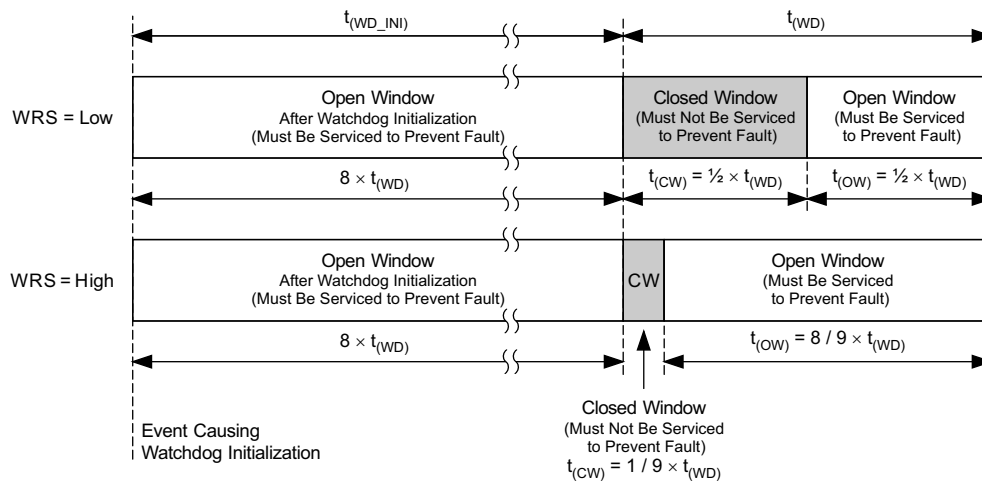
$$\text{FSEL low} \quad t_{(WD)} = R_{ROSC} \times 0.5 \times 10^{-6} \quad (9)$$

$$\text{FSEL high} \quad t_{(WD)} = R_{ROSC} \times 2.5 \times 10^{-6} \quad (10)$$

$$\text{Watchdog initialization} \quad t_{(WD_INI)} = 8 \times t_{(WD)} \quad (11)$$

where:

- $t_{(WD)}$ is the duration of the watchdog window
- R_{ROSC} is the resistor connected at the ROOSC pin
- $t_{(WD_INI)}$ is the duration of the watchdog initialization

For all the foregoing items, the unit of resistance is Ω and the unit of time is s

Compared with window watchdog, there is no closed window in standard watchdog mode. The standard watchdog receives a service signal at any time within the watchdog window. The watchdog fault occurs when not servicing watchdog during the watchdog window.

7.3.7.3 Watchdog Service Signal and Watchdog Fault Outputs (WD and WDO)

The watchdog service signal (WD) must stay high for at least 100 μ s. The WDO pin is the fault output terminal and is tied high through a pullup resistor to a regulated output supply. When a watchdog fault occurs, the devices momentarily pull WDO low for a duration of $t_{(WD_HOLD)}$.

$$t_{(WD_HOLD)} = 20\% \times t_{(WD)} \quad (12)$$

7.3.7.4 ROOSC Status Detection (ROSC)

When a watchdog function is enabled, if the ROOSC pin is shorted to GND or open, the watchdog output (WDO) pin remains low, indicating a fault status. If the watchdog function is disabled, ROOSC pin status detection does not work.

7.3.7.5 Watchdog Enable (PG and $\overline{WD_EN}$)

When PG (power good) is high, an external microcontroller or a digital circuit can apply a high or low logic signal to the $\overline{WD_EN}$ pin to disable or enable the watchdog. A low input to this pin turns the watchdog on, and a high input turns the watchdog off. If PG is low, the watchdog is disabled and the watchdog-fault output (WDO) pin stays in the high-impedance state.

7.3.7.6 Watchdog Initialization

On power up and during normal operation, the watchdog initializes under the conditions shown in [表 7-2](#).

表 7-2. Conditions for Watchdog Initialization

EDGE	WHAT CAUSES THE WATCHDOG TO INITIALIZE
↑	Rising edge of PG (power good) while the watchdog is in the enabled state, for example, during soft power up
↓	Falling edge of $\overline{WD_EN}$ while PG is already high, for example, when the microprocessor enables the watchdog after the device is powered up
↑	Rising edge of WDO while PG is already high and the watchdog is in the enabled state, for example, right after a closed window is serviced

7.3.7.7 Window Watchdog Operation (WTS = Low)

The window watchdog is able to monitor whether the frequency of the watchdog service signal (WD) is within certain ranges. A watchdog low-voltage fault is reported when the frequency of the watchdog service signal is out of the setting range. 图 7-4 shows the window watchdog initialization and operation for the TPS7B63xx-Q1 (WRS is low). After the output voltage is in regulation and PG is high, the window watchdog becomes enabled when an external signal pulls $\overline{\text{WD_EN}}$ (the watchdog enable pin) low. This causes the watchdog to initialize and wait for a service signal during the first initialization window for 8 times the duration of t_{WD} . A service signal applied to the WD pin during the initialization open window resets the watchdog counter and a closed window starts. To prevent a fault condition from occurring, watchdog service must not occur during the closed window. Watchdog service must occur during the following open window to prevent a fault condition from occurring. The fault output (WDO), externally pulled up to V_{OUT} (typical), stays high as long as the watchdog receives a proper service signal and there is no other fault condition.



图 7-4. Window Watchdog Operation

Three different fault conditions occur in 图 7-4:

- Fault 1: The watchdog service signal is received during the closed window. The WDO is triggered once, receiving a WD rising edge during the closed window.
- Fault 2: The watchdog service signal is not received during the open window. WDO is triggered after the maximum open-window duration $t_{\text{WD}} / 2$.
- Fault 3: The watchdog service signal is not received during the WD initialization. WDO is triggered after the maximum initialization window duration $8 \times t_{\text{WD}}$.

7.3.7.8 Standard Watchdog Operation (WTS = High)

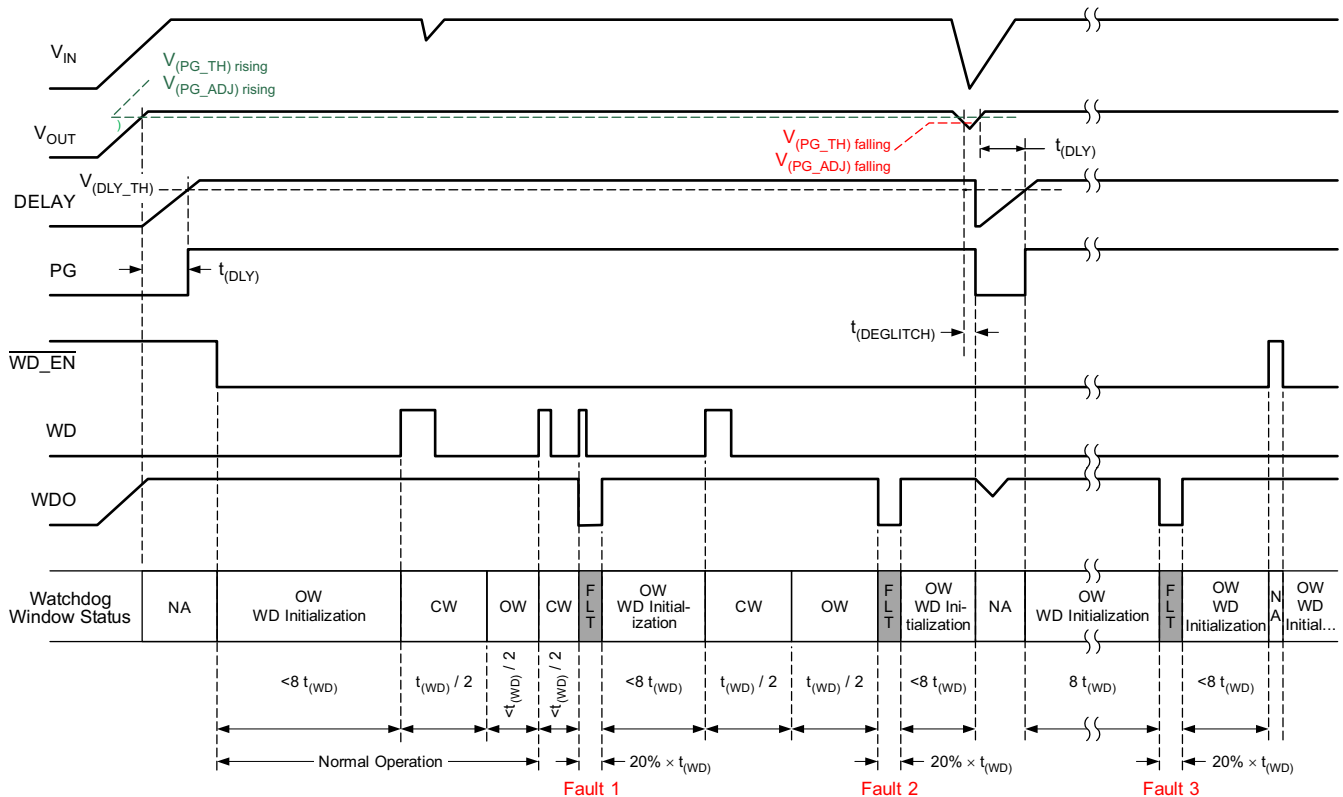
The standard watchdog is able to monitor whether the frequency of the watchdog service signal (WD) is lower than a certain value. A watchdog low-voltage fault is reported when the frequency of the watchdog service signal is lower than the set value.

图 7-5 shows the standard watchdog initialization and operation for the TPS7B63xx-Q1. Similar to the window watchdog, after output the voltage is in regulation and PG asserts high, the standard watchdog becomes enabled when an external signal pulls WD_EN low. This causes the standard watchdog to initialize and wait for a service signal during the first initialization window for 8 times the duration of $t_{(WD)}$. A service signal applied to the WD pin during the first open window resets the watchdog counter and another open window starts. To prevent a fault condition from occurring, watchdog service must occur during the every open window to prevent a fault condition from occurring. The fault output (WDO), externally pulled up to V_{OUT} (typical), stays high as long as the watchdog receives proper service and there is not fault condition.



图 7-5. Standard Watchdog Operation

Two different fault conditions occur in 图 7-5:

- Fault 1: The watchdog service signal is not received during the open window. WDO is triggered after the maximum open-window duration $t_{(WD)}$.
- Fault 2: The watchdog service signal is not received during the WD initialization. WDO is triggered after the maximum initialization window duration $8 \times t_{(WD)}$.

7.4 Device Functional Modes

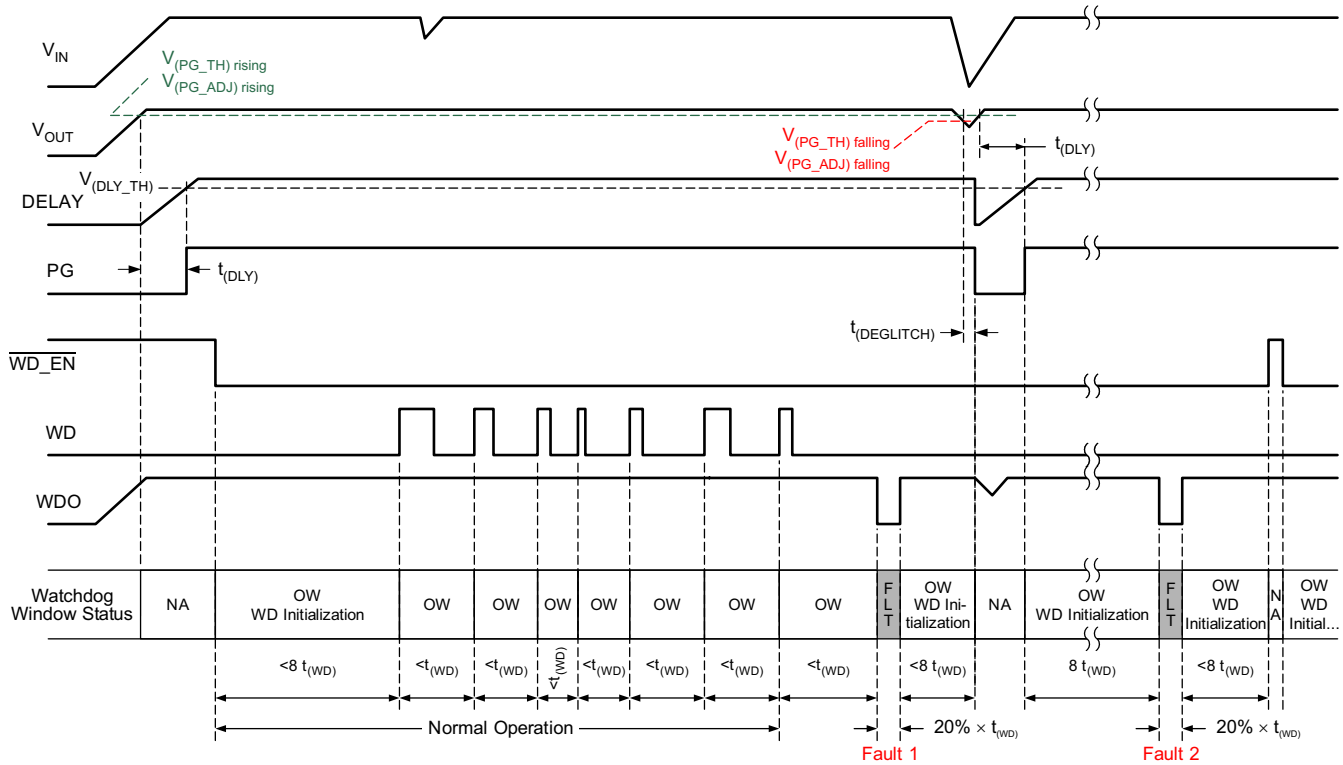
7.4.1 Operation With Input Voltage Lower Than 4 V

The devices normally operate with input voltages above 4 V. The devices can also operate at lower input voltages; the maximum UVLO voltage is 2.6 V. At input voltages below the actual UVLO voltage, the devices do not operate.

7.4.2 Operation With Input Voltage Higher Than 4 V

When the input voltage is greater than 4 V, if the input voltage is higher than the output set value plus the device dropout voltage, then the output voltage is equal to the set value. Otherwise, the output voltage is equal to the input voltage minus the dropout voltage.

8 Application and Implementation

备注

以下应用部分中的信息不属于 TI 器件规格的范围，TI 不担保其准确性和完整性。TI 的客户应负责确定器件是否适用于其应用。客户应验证并测试其设计，以确保系统功能。

8.1 Application Information

The TPS7B63xx-Q1 is a 300-mA low-dropout watchdog linear regulator with ultralow quiescent current. The PSpice transient model is available for download on the product folder and can be used to evaluate the basic function of the device.

8.2 Typical Application

图 8-1 shows a typical application circuit for the TPS7B63xx-Q1 device. Different values of external components can be used, depending on the end application. An application may require a larger output capacitor during fast load steps to prevent a large drop on the output voltage. TI recommends using a low-ESR ceramic capacitor with a dielectric of type X7R.



图 8-1. TPS7B63xx-Q1 Typical Application Schematic

8.2.1 Design Requirements

For this design example, use the parameters listed in [表 8-1](#).

表 8-1. Design Parameters

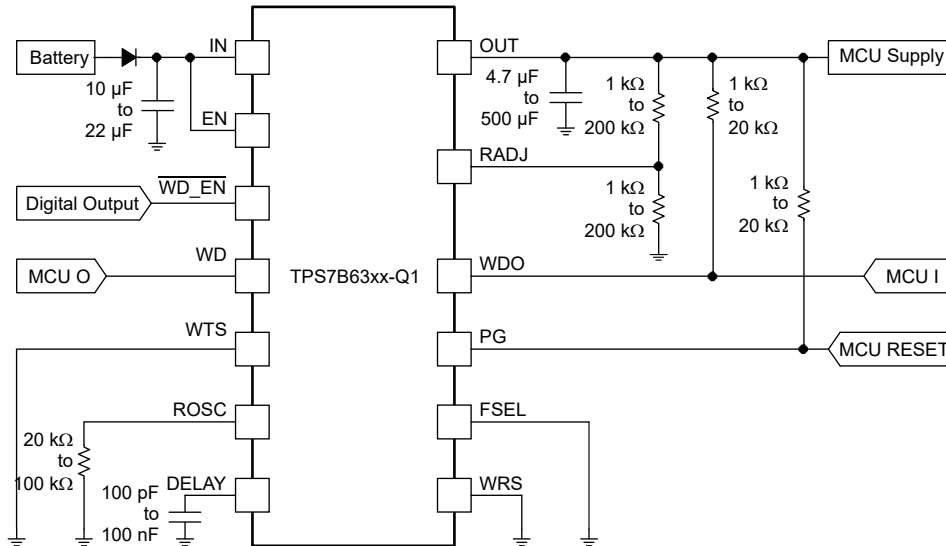
DESIGN PARAMETER	EXAMPLE VALUES
Input voltage range	4 V to 40 V for TPS7B6333-Q1 5.6 V to 40 V for TPS7B6350-Q1
Input capacitor range	10 μ F to 22 μ F
Output voltage	3.3 V, 5 V
Output current rating	300 mA maximum
Output capacitor range	4.7 μ F to 500 μ F
Power-good threshold	Adjustable or fixed
Power-good delay capacitor	100 pF to 100 nF
Watchdog type	Standard watchdog or window watchdog
Watchdog window periods	10 ms to 500 ms

8.2.2 Detailed Design Procedure

To begin the design process, determine the following:

- Input voltage range
- Output voltage
- Output current
- Power-good threshold
- Power-good delay capacitor
- Watchdog type
- Watchdog window period

8.2.2.1 Input Capacitor

When using a TPS7B63xx-Q1 device, TI recommends adding a 10- μ F to 22- μ F capacitor with a 0.1 μ F ceramic bypass capacitor in parallel at the input to keep the input voltage stable. The voltage rating must be greater than the maximum input voltage.

8.2.2.2 Output Capacitor

Ensuring the stability of the TPS7B63xx-Q1 device requires an output capacitor with a value in the range from 4.7 μ F to 500 μ F and with an ESR range from 0.001 Ω to 20 Ω . TI recommends selecting a ceramic capacitor with low ESR to improve the load transient response.

8.2.2.3 Power-Good Threshold

The power-good threshold is set by connecting PGADJ to GND or to a resistor divider from OUT to GND. The [Adjustable Power-Good Threshold \(PG, PGADJ\)](#) section provides the method for setup of the power-good threshold.

8.2.2.4 Power-Good Delay Period

The power-good delay period is set by an external capacitor (C_{DELAY}) to ground, with a typical capacitor value from 100 pF to 100 nF. Calculate the correct capacitance for the application using [方程式 2](#).

8.2.2.5 Watchdog Setup

The [Integrated Watchdog](#) section discusses the watchdog type selection and watchdog window-period setup method.

8.2.3 Application Curves



图 8-2. TPS7B6350-Q1 Power-Up Waveform



图 8-3. TPS7B6350-Q1 Watchdog Fault (High-Frequency Watchdog Service Signal)

8.3 Power Supply Recommendations

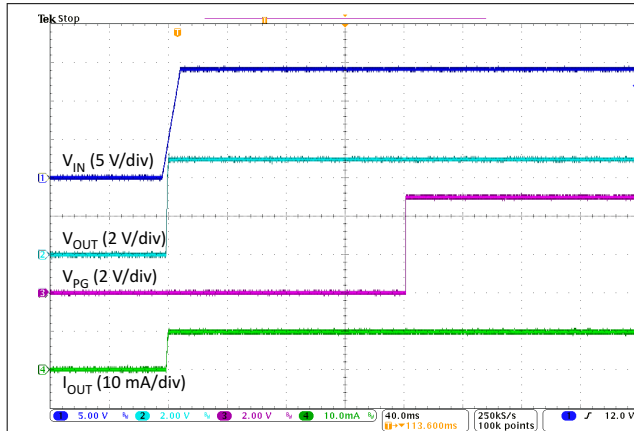
The device is designed to operate from an input-voltage supply range from 4 V to 40 V. This input supply must be well regulated. If the input supply is located more than a few inches from the TPS7B63xx-Q1 device, TI recommends adding a capacitor with a value of $\geq 10 \mu\text{F}$ with a $0.1 \mu\text{F}$ ceramic bypass capacitor in parallel at the input.

8.4 Layout

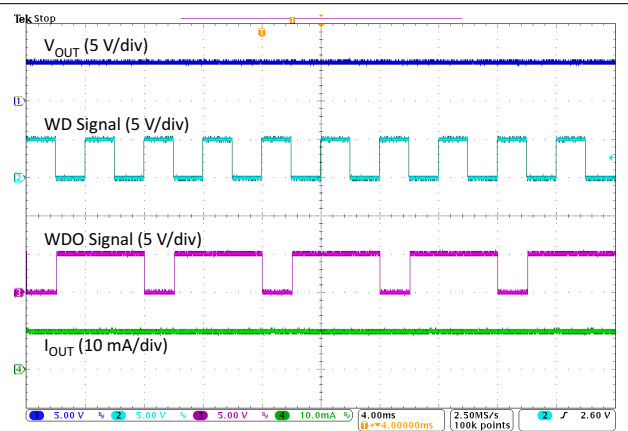
8.4.1 Layout Guidelines

For LDO power supplies, especially high-voltage and high-current ones, layout is an important step. If layout is not carefully designed, the regulator could not deliver enough output current because of thermal limitation. To improve the thermal performance of the device and maximize the current output at high ambient temperature, TI recommends spreading the thermal pad as much as possible and putting enough thermal vias on the thermal pad. [Figure 8-4](#) shows an example layout.

8.4.2 Layout Example



图 8-4. Layout Recommendation

9 Device and Documentation Support

9.1 Documentation Support

9.1.1 Related Documentation

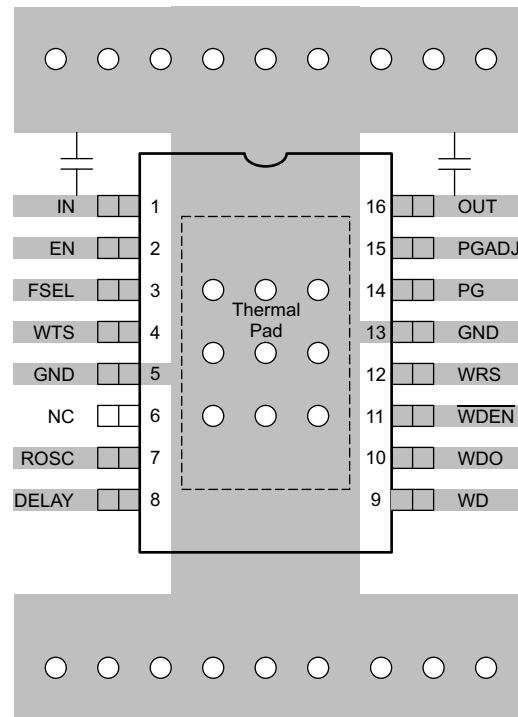
For related documentation see the following:

Texas Instruments, [TPS7B63xx-Q1 Evaluation Module user's guide](#)

9.2 接收文档更新通知

要接收文档更新通知，请导航至 [ti.com](#) 上的器件产品文件夹。点击 [订阅更新](#) 进行注册，即可每周接收产品信息更改摘要。有关更改的详细信息，请查看任何已修订文档中包含的修订历史记录。

9.3 支持资源

[TI E2E™ 支持论坛](#) 是工程师的重要参考资料，可直接从专家获得快速、经过验证的解答和设计帮助。搜索现有解答或提出自己的问题可获得所需的快速设计帮助。

链接的内容由各个贡献者“按原样”提供。这些内容并不构成 TI 技术规范，并且不一定反映 TI 的观点；请参阅 TI 的 [《使用条款》](#)。

9.4 Trademarks

PowerPAD™ and TI E2E™ are trademarks of Texas Instruments.

所有商标均为其各自所有者的财产。

9.5 Electrostatic Discharge Caution



This integrated circuit can be damaged by ESD. Texas Instruments recommends that all integrated circuits be handled with appropriate precautions. Failure to observe proper handling and installation procedures can cause damage.

ESD damage can range from subtle performance degradation to complete device failure. Precision integrated circuits may be more susceptible to damage because very small parametric changes could cause the device not to meet its published specifications.

9.6 术语表

[TI 术语表](#) 本术语表列出并解释了术语、首字母缩略词和定义。

10 Mechanical, Packaging, and Orderable Information

The following pages include mechanical, packaging, and orderable information. This information is the most-current data available for the designated devices. This data is subject to change without notice and without revision of this document. For browser-based versions of this data sheet, see the left-hand navigation pane.

PACKAGING INFORMATION

Orderable part number	Status (1)	Material type (2)	Package Pins	Package qty Carrier	RoHS (3)	Lead finish/ Ball material (4)	MSL rating/ Peak reflow (5)	Op temp (°C)	Part marking (6)
TPS7B6333QPWPRQ1	Active	Production	HTSSOP (PWP) 16	2000 LARGE T&R	Yes	NIPDAU	Level-3-260C-168 HR	-40 to 125	7B6333Q
TPS7B6333QPWPRQ1.A	Active	Production	HTSSOP (PWP) 16	2000 LARGE T&R	Yes	NIPDAU	Level-3-260C-168 HR	-40 to 125	7B6333Q
TPS7B6350QPWPRQ1	Active	Production	HTSSOP (PWP) 16	2000 LARGE T&R	Yes	NIPDAU	Level-3-260C-168 HR	-40 to 125	7B6350Q
TPS7B6350QPWPRQ1.A	Active	Production	HTSSOP (PWP) 16	2000 LARGE T&R	Yes	NIPDAU	Level-3-260C-168 HR	-40 to 125	7B6350Q

(1) **Status:** For more details on status, see our [product life cycle](#).

(2) **Material type:** When designated, preproduction parts are prototypes/experimental devices, and are not yet approved or released for full production. Testing and final process, including without limitation quality assurance, reliability performance testing, and/or process qualification, may not yet be complete, and this item is subject to further changes or possible discontinuation. If available for ordering, purchases will be subject to an additional waiver at checkout, and are intended for early internal evaluation purposes only. These items are sold without warranties of any kind.

(3) **RoHS values:** Yes, No, RoHS Exempt. See the [TI RoHS Statement](#) for additional information and value definition.

(4) **Lead finish/Ball material:** Parts may have multiple material finish options. Finish options are separated by a vertical ruled line. Lead finish/Ball material values may wrap to two lines if the finish value exceeds the maximum column width.

(5) **MSL rating/Peak reflow:** The moisture sensitivity level ratings and peak solder (reflow) temperatures. In the event that a part has multiple moisture sensitivity ratings, only the lowest level per JEDEC standards is shown. Refer to the shipping label for the actual reflow temperature that will be used to mount the part to the printed circuit board.

(6) **Part marking:** There may be an additional marking, which relates to the logo, the lot trace code information, or the environmental category of the part.

Multiple part markings will be inside parentheses. Only one part marking contained in parentheses and separated by a "~" will appear on a part. If a line is indented then it is a continuation of the previous line and the two combined represent the entire part marking for that device.

Important Information and Disclaimer: The information provided on this page represents TI's knowledge and belief as of the date that it is provided. TI bases its knowledge and belief on information provided by third parties, and makes no representation or warranty as to the accuracy of such information. Efforts are underway to better integrate information from third parties. TI has taken and continues to take reasonable steps to provide representative and accurate information but may not have conducted destructive testing or chemical analysis on incoming materials and chemicals. TI and TI suppliers consider certain information to be proprietary, and thus CAS numbers and other limited information may not be available for release.

In no event shall TI's liability arising out of such information exceed the total purchase price of the TI part(s) at issue in this document sold by TI to Customer on an annual basis.

TAPE AND REEL INFORMATION

QUADRANT ASSIGNMENTS FOR PIN 1 ORIENTATION IN TAPE



*All dimensions are nominal

Device	Package Type	Package Drawing	Pins	SPQ	Reel Diameter (mm)	Reel Width W1 (mm)	A0 (mm)	B0 (mm)	K0 (mm)	P1 (mm)	W (mm)	Pin1 Quadrant
TPS7B6333QPWPRQ1	HTSSOP	PWP	16	2000	330.0	12.4	6.9	5.6	1.6	8.0	12.0	Q1
TPS7B6350QPWPRQ1	HTSSOP	PWP	16	2000	330.0	12.4	6.9	5.6	1.6	8.0	12.0	Q1

TAPE AND REEL BOX DIMENSIONS

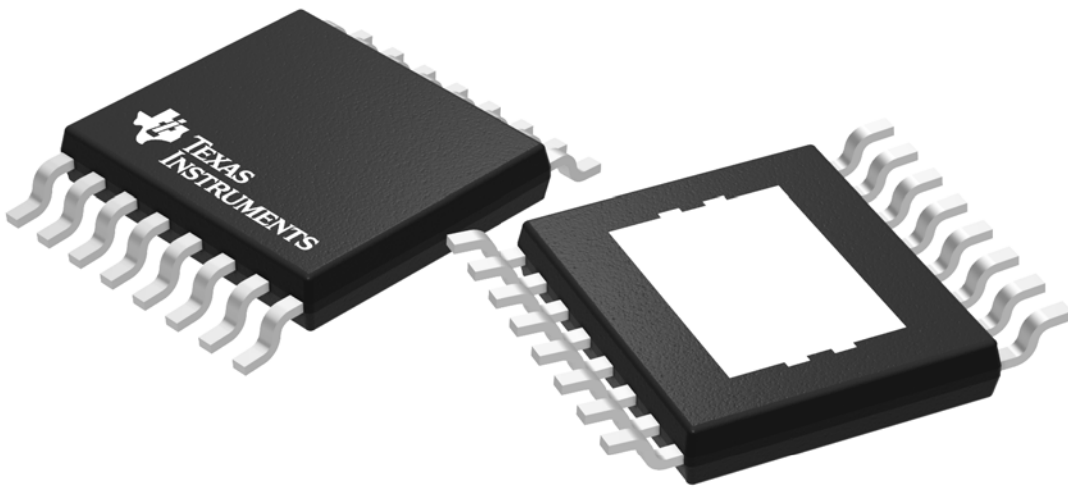

*All dimensions are nominal

Device	Package Type	Package Drawing	Pins	SPQ	Length (mm)	Width (mm)	Height (mm)
TPS7B6333QPWRQ1	HTSSOP	PWP	16	2000	350.0	350.0	43.0
TPS7B6350QPWRQ1	HTSSOP	PWP	16	2000	350.0	350.0	43.0

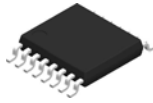

Images above are just a representation of the package family, actual package may vary.
Refer to the product data sheet for package details.

PWP0016J



PACKAGE OUTLINE

PowerPAD™ TSSOP - 1.2 mm max height

SMALL OUTLINE PACKAGE

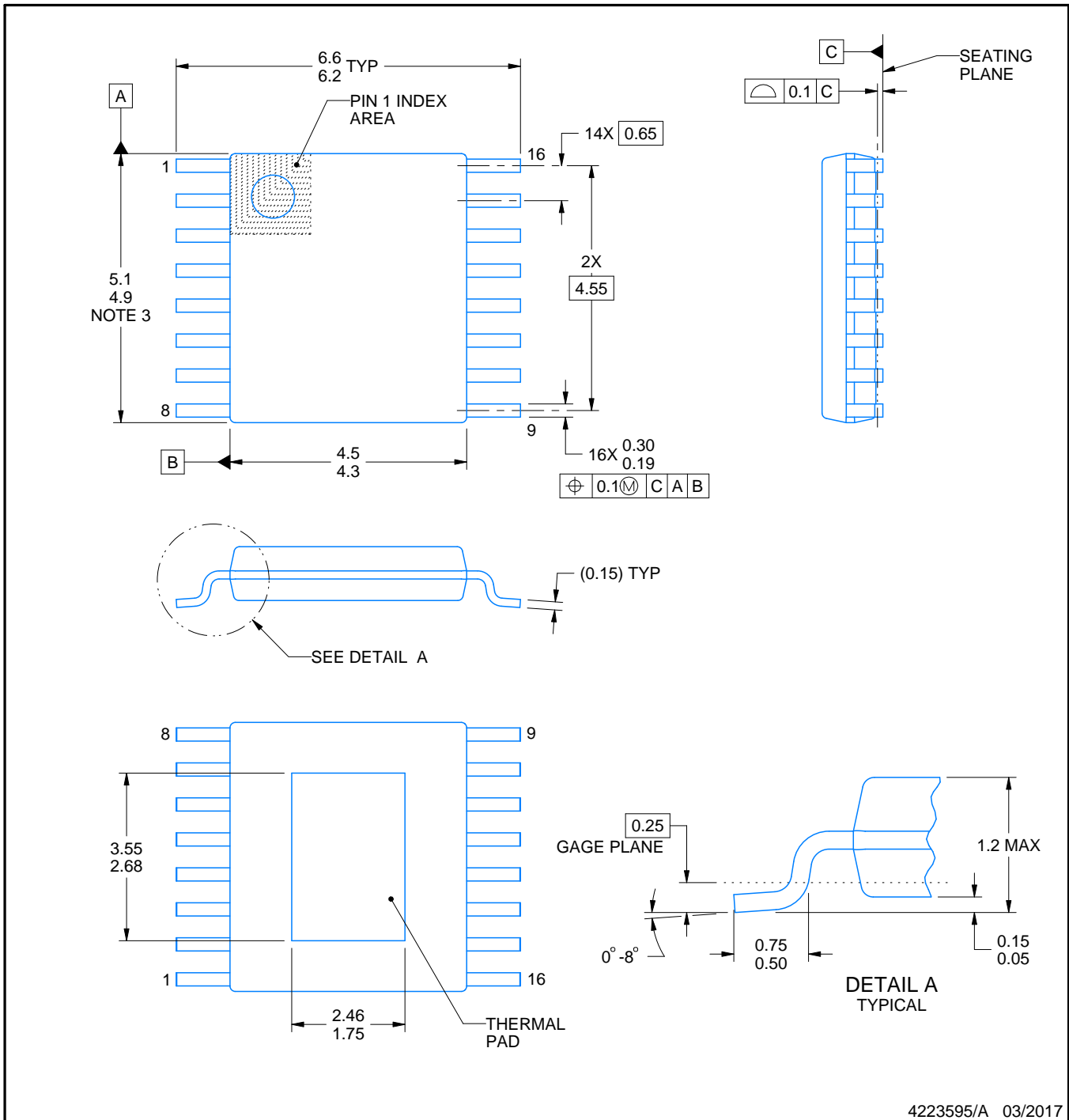

4223595/A 03/2017

NOTES:

PowerPAD is a trademark of Texas Instruments.

1. All linear dimensions are in millimeters. Any dimensions in parenthesis are for reference only. Dimensioning and tolerancing per ASME Y14.5M.
2. This drawing is subject to change without notice.
3. This dimension does not include mold flash, protrusions, or gate burrs. Mold flash, protrusions, or gate burrs shall not exceed 0.15 mm per side.
4. Reference JEDEC registration MO-153.

EXAMPLE BOARD LAYOUT

PWP0016J

PowerPAD™ TSSOP - 1.2 mm max height

SMALL OUTLINE PACKAGE

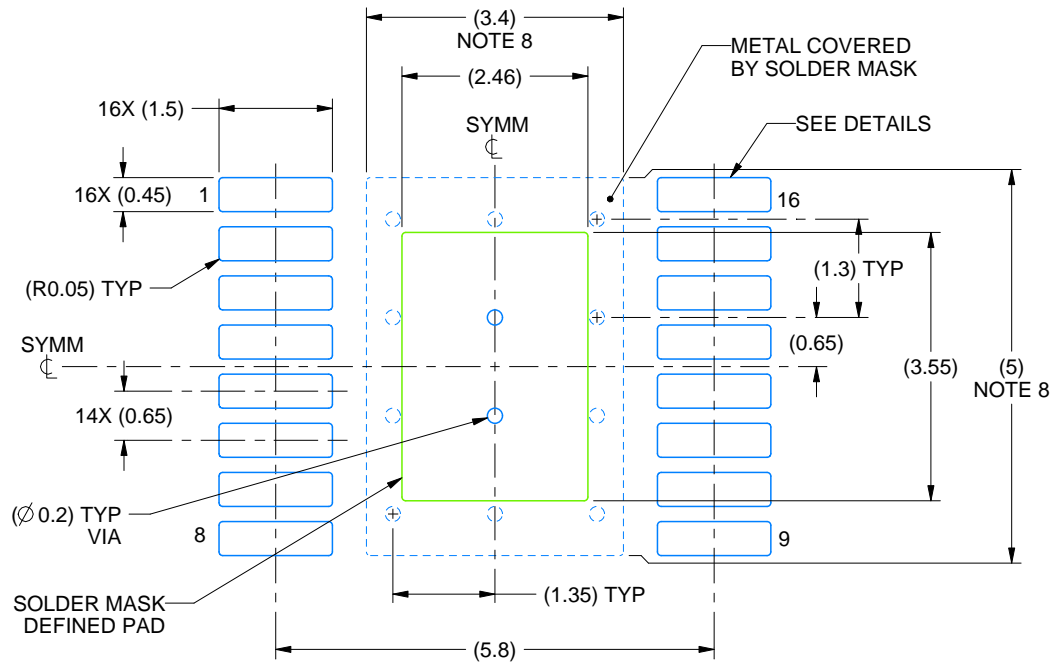

LAND PATTERN EXAMPLE
EXPOSED METAL SHOWN
SCALE: 10X

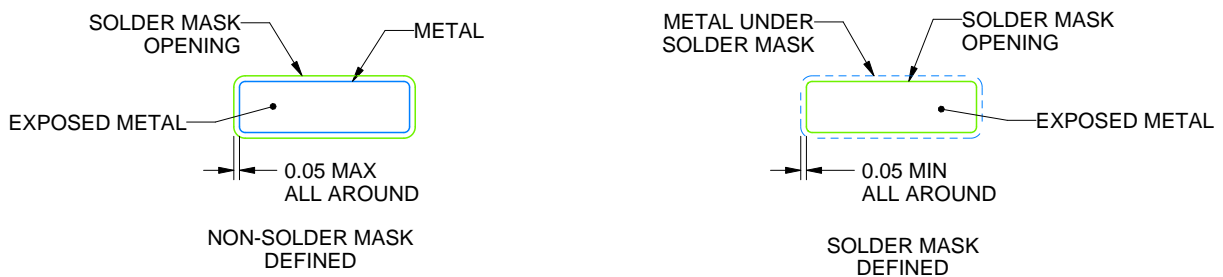

SOLDER MASK DETAILS

4223595/A 03/2017

NOTES: (continued)

5. Publication IPC-7351 may have alternate designs.
6. Solder mask tolerances between and around signal pads can vary based on board fabrication site.
7. This package is designed to be soldered to a thermal pad on the board. For more information, see Texas Instruments literature numbers SLMA002 (www.ti.com/lit/slma002) and SLMA004 (www.ti.com/lit/slma004).
8. Size of metal pad may vary due to creepage requirement.
9. Vias are optional depending on application, refer to device data sheet. It is recommended that vias under paste be filled, plugged or tented.

EXAMPLE STENCIL DESIGN

PWP0016J

PowerPAD™ TSSOP - 1.2 mm max height

SMALL OUTLINE PACKAGE

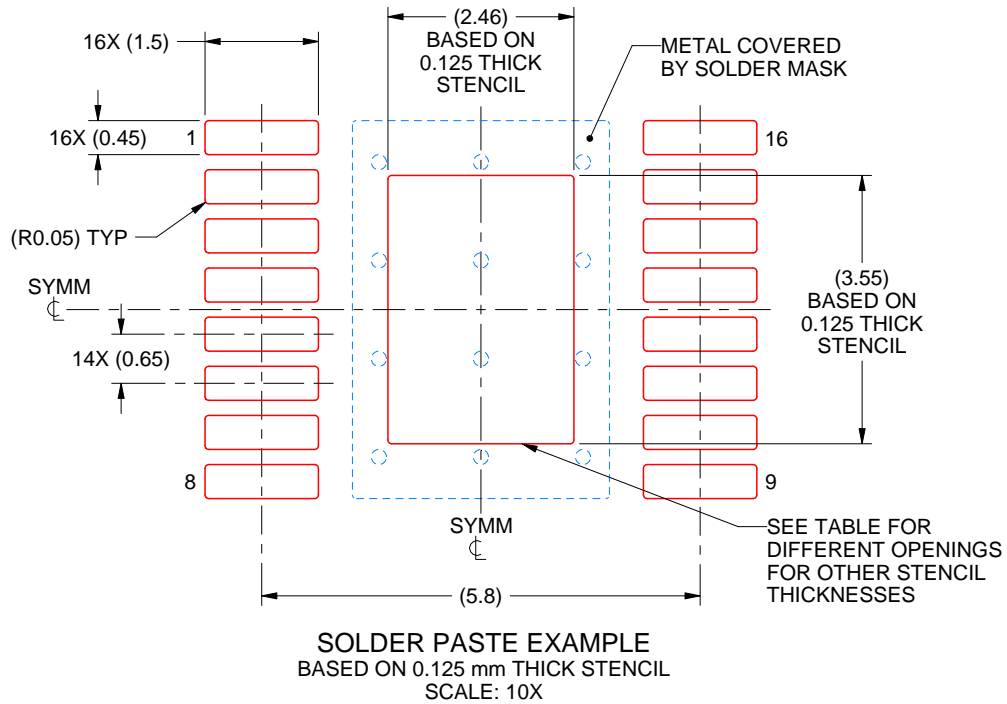

STENCIL THICKNESS	SOLDER STENCIL OPENING
0.1	2.75 X 3.97
0.125	2.46 X 3.55 (SHOWN)
0.15	2.25 X 3.24
0.175	2.08 X 3.00

4223595/A 03/2017

NOTES: (continued)

10. Laser cutting apertures with trapezoidal walls and rounded corners may offer better paste release. IPC-7525 may have alternate design recommendations.
11. Board assembly site may have different recommendations for stencil design.

重要通知和免责声明

TI“按原样”提供技术和可靠性数据（包括数据表）、设计资源（包括参考设计）、应用或其他设计建议、网络工具、安全信息和其他资源，不保证没有瑕疵且不做任何明示或暗示的担保，包括但不限于对适销性、某特定用途方面的适用性或不侵犯任何第三方知识产权的暗示担保。

这些资源可供使用 TI 产品进行设计的熟练开发人员使用。您将自行承担以下全部责任：(1) 针对您的应用选择合适的 TI 产品，(2) 设计、验证并测试您的应用，(3) 确保您的应用满足相应标准以及任何其他功能安全、信息安全、监管或其他要求。

这些资源如有变更，恕不另行通知。TI 授权您仅可将这些资源用于研发本资源所述的 TI 产品的相关应用。严禁以其他方式对这些资源进行复制或展示。您无权使用任何其他 TI 知识产权或任何第三方知识产权。您应全额赔偿因在这些资源的使用中对 TI 及其代表造成的任何索赔、损害、成本、损失和债务，TI 对此概不负责。

TI 提供的产品受 [TI 的销售条款](#) 或 [ti.com](#) 上其他适用条款/TI 产品随附的其他适用条款的约束。TI 提供这些资源并不会扩展或以其他方式更改 TI 针对 TI 产品发布的适用的担保或担保免责声明。

TI 反对并拒绝您可能提出的任何其他或不同的条款。

邮寄地址：Texas Instruments, Post Office Box 655303, Dallas, Texas 75265
版权所有 © 2025，德州仪器 (TI) 公司