

# TPS22810, 具有热保护的 2.7V-18V、79mΩ 导通电阻负载开关

## 1 特性

- 集成单通道负载开关
- 运行环境温度范围:  
–40°C 至 +105°C
  - SOT23-6 (DBV): 2A 最大持续工作电流<sup>1</sup>
  - WSON (DRV): 3A 最大持续电流<sup>1</sup>
- 输入电压范围: 2.7V 至 18V
- 绝对最大输入电压: 20V
- 导通电阻 ( $R_{ON}$ )
  - $R_{ON} = 79m\Omega$  ( $V_{IN} = 12V$  时的典型值)
- 静态电流
  - 62 $\mu A$  ( $V_{IN} = 12V$  时的典型值)
- 关断电流
  - 500nA ( $V_{IN} = 12V$  时的典型值)
- 热关断
- 欠压闭锁 (UVLO)
- 可调节快速输出放电 (QOD)
- 可通过 CT 引脚配置的上升时间
- 小外形尺寸晶体管 (SOT) 23-6 封装
  - 2.9mm x 2.8mm, 0.95mm 间距, 1.45mm 高 (DBV)
- WSON 封装
  - 2mm x 2mm, 0.65mm 间距, 0.75mm 高 (DRV)
- 静电放电 (ESD) 性能经测试符合 JESD 22 规范
  - $\pm 2kV$  人体模型 (HBM) 和  $\pm 1kV$  带电器件模型 (CDM)

(1) 必须考虑热性能

## 2 应用

- 高清电视
- 工业系统
- 机顶盒
- 监控系统

## 3 说明

TPS22810 是一款单通道负载开关, 其具有可配置的上升时间并集成有快速输出放电 (QOD) 功能。此外, 该器件还具有热关断保护, 可防止器件结温过高, 借此从内部确保器件处于安全工作区域。该器件包括一个 N 通道金属氧化物半导体场效应晶体管 (MOSFET), 可在 2.7V 至 18V 的输入电压范围内运行。SOT23-5 (DBV) 封装可支持 2A 的最大电流。WSON (DRV) 封装可支持 3A 的最大电流。此开关由一个开关输入控制, 能够直接连接低电压控制信号。

该器件的可配置上升时间可大幅降低大容量负载电容所产生的浪涌电流, 从而降低或消除电源压降。欠压闭锁用于在  $V_{IN}$  电压降至阈值以下时关闭器件, 以确保下游电路不会因为供电电压低于预期值而损坏。可配置的快速输出放电 (QOD) 引脚控制器件的下降时间, 以便针对掉电进行灵活设计。

TPS22810 采用方便目测检查焊点的带引线 SOT-23 封装 (DBV) 以及 WSON 封装 (DRV)。该器件在自然通风环境下的额定运行温度范围为 -40°C 至 +105°C。删除的  $I_{MAX}$  和  $I_{PLS}$

### Device Information<sup>(1)</sup>

PART NUMBER	PACKAGE	BODY SIZE (NOM)
TPS22810	SOT-23 (6)	2.90mm x 2.80mm
	WSON (6)	2.00mm x 2.00mm

(1) 要了解所有可用封装, 请参见数据表末尾的可订购产品附录。

### 简化原理图

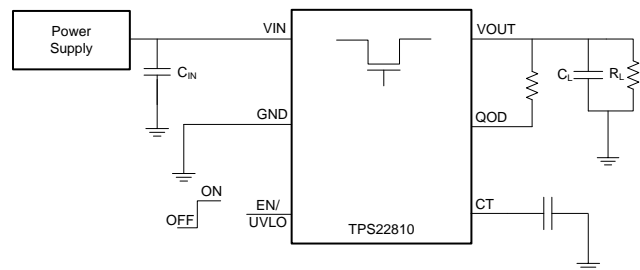

Copyright © 2016, Texas Instruments Incorporated



## 目录

1 特性 .....	1	9.4 Device Functional Modes .....	17
2 应用 .....	1	<b>10 Application and Implementation</b> .....	<b>18</b>
3 说明 .....	1	10.1 Application Information .....	18
4 修订历史记录 .....	2	10.2 ON and OFF Control .....	18
<b>5 Device Comparison Table</b> .....	<b>3</b>	10.3 Input Capacitor (Optional) .....	18
<b>6 Pin Configuration and Functions</b> .....	<b>3</b>	10.4 Output Capacitor (Optional) .....	18
<b>7 Specifications</b> .....	<b>4</b>	10.5 Typical Application .....	18
7.1 Absolute Maximum Ratings .....	4	<b>11 Power Supply Recommendations</b> .....	<b>23</b>
7.2 ESD Ratings .....	4	<b>12 Layout</b> .....	<b>24</b>
7.3 Recommended Operating Conditions .....	4	12.1 Layout Guidelines .....	24
7.4 Thermal Information .....	4	12.2 Layout Example .....	24
7.5 Electrical Characteristics .....	5	12.3 Thermal Considerations .....	24
7.6 Switching Characteristics .....	7	<b>13 器件和文档支持</b> .....	<b>25</b>
7.7 Typical DC Characteristics .....	8	13.1 器件支持 .....	25
7.8 Typical AC Characteristics .....	9	13.2 Documentation Support .....	25
<b>8 Parameter Measurement Information</b> .....	<b>11</b>	13.3 接收文档更新通知 .....	25
<b>9 Detailed Description</b> .....	<b>12</b>	13.4 Community Resources .....	25
9.1 Overview .....	12	13.5 商标 .....	25
9.2 Functional Block Diagram .....	13	13.6 静电放电警告 .....	25
9.3 Feature Description .....	13	13.7 Glossary .....	25
		<b>14 机械、封装和可订购信息</b> .....	<b>25</b>

## 4 修订历史记录

Changes from Revision B (May 2017) to Revision C	Page
<ul style="list-style-type: none"> <li>Changed Rise time can be calculated by multiplying to Rise time can be calculated by dividing in the <i>Feature Description</i> Section 9.3.4 <i>Adjustable Rise Time (CT)</i> .....</li> </ul>	17

Changes from Revision A (December2016) to Revision B	Page
<ul style="list-style-type: none"> <li>将 WSON (DRV) 的当前信息添加至特性，说明部分和建议运行条件表中 .....</li> <li>已添加 WSON (DRV) 封装 .....</li> </ul>	1

Changes from Original (December 2016) to Revision A	Page
<ul style="list-style-type: none"> <li>从绝对最大额定值表中 .....</li> <li>Deleted <math>I_{MAX}</math> and <math>I_{PLS}</math> from the <i>Absolute Maximum Ratings</i> table .....</li> <li>Changed the Quiescent current MAX value From: 70 <math>\mu A</math> To: 80 <math>\mu A</math> in the <i>Electrical Characteristics</i> table .....</li> <li>Changed the Quiescent current MAX value for <math>V_{IN} = 2.7 V</math> From: 60 <math>\mu A</math> To: 70 <math>\mu A</math> in the <i>Electrical Characteristics</i> table .....</li> <li>Changed the Shutdown current MAX value From: 2.25 <math>\mu A</math> To: 2.3 <math>\mu A</math> in the <i>Electrical Characteristics</i> table .....</li> </ul>	1 4 5 5 5

## 5 Device Comparison Table

DEVICE	R <sub>ON</sub> at 12 V	Package	QUICK OUTPUT DISCHARGE	T <sub>A</sub>	MAXIMUM OUTPUT CURRENT	ENABLE
TPS22810	79 mΩ	DBV	Configurable	105°C	2 A	Active High
TPS22810	79 mΩ	DRV	Configurable	105°C	3 A	Active High

## 6 Pin Configuration and Functions

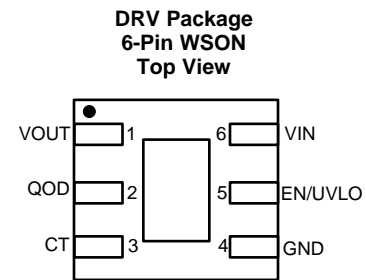
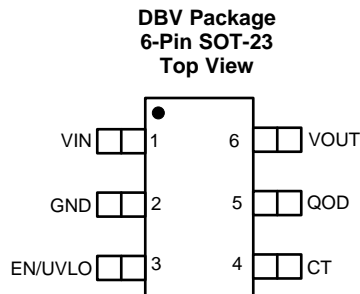

### Pin Functions

NAME	PIN NO,		I/O	DESCRIPTION
	SOT23	WSON		
CT	4	3	O	Switch slew rate control. Can be left floating
EN/UVLO	3	5	I	Active high switch control input and UVLO adjustment. Do not leave floating
GND	2	4	—	Device ground
QOD	5	2	O	Quick Output Discharge pin. This functionality can be enabled in one of three ways. <ul style="list-style-type: none"> <li>Placing an external resistor between VOUT and QOD</li> <li>Tying QOD directly to VOUT and using the internal resistor value (R<sub>PD</sub>)</li> <li>Disabling QOD by leaving pin floating</li> </ul> See the <a href="#">Quick Output Discharge (QOD)</a> for more information
VIN	1	6	I	Switch input. Place ceramic bypass capacitor(s) between this pin and GND
VOUT	6	1	O	Switch output

## 7 Specifications

### 7.1 Absolute Maximum Ratings

Over operating free-air temperature range (unless otherwise noted) <sup>(1)</sup> <sup>(2)</sup>

		MIN	MAX	UNIT
V <sub>IN</sub>	Input voltage	-0.3	20	V
V <sub>OUT</sub>	Output voltage	-0.3	min(V <sub>IN</sub> + 0.3, 20)	V
V <sub>EN/UVLO</sub>	EN/UVLO voltage	-0.3	20	V
T <sub>J</sub>	Maximum junction temperature		150	°C
T <sub>stg</sub>	Storage temperature	-65	150	°C

- (1) Stresses beyond those listed under *Absolute Maximum Ratings* may cause permanent damage to the device. These are stress ratings only, which do not imply functional operation of the device at these or any other conditions beyond those indicated under *Recommended Operating Conditions*. Exposure to absolute-maximum-rated conditions for extended periods may affect device reliability.
- (2) All voltage values are with respect to network ground terminal.

### 7.2 ESD Ratings

			VALUE	UNIT
V <sub>(ESD)</sub>	Electrostatic discharge	Human-body model (HBM), per ANSI/ESDA/JEDEC JS-001 <sup>(1)</sup>	±2000	V
		Charged-device model (CDM), per JEDEC specification JESD22-C101 <sup>(2)</sup>	±1000	

- (1) JEDEC document JEP155 states that 500-V HBM allows safe manufacturing with a standard ESD control process. Manufacturing with less than 500-V HBM is possible with the necessary precautions.
- (2) JEDEC document JEP157 states that 250-V CDM allows safe manufacturing with a standard ESD control process. Manufacturing with less than 250-V CDM is possible with the necessary precautions.

### 7.3 Recommended Operating Conditions

Over operating free-air temperature range (unless otherwise noted)

		MIN	MAX	UNIT
V <sub>IN</sub>	Input voltage	2.7	18	V
V <sub>EN/UVLO</sub>	EN/UVLO voltage	0	18	V
V <sub>OUT</sub>	Output voltage		V <sub>IN</sub>	V
I <sub>MAX</sub>	Maximum continuous switch current, T <sub>A</sub> = 65°C (DBV)		2	A
	Maximum continuous switch current, T <sub>A</sub> = 65°C (DRV)		3	
T <sub>A</sub>	Operating free-air temperature <sup>(1)</sup>	-40	105	°C
C <sub>IN</sub>	Input capacitor	1 <sup>(2)</sup>		µF

- (1) In applications where high power dissipation and/or poor package thermal resistance is present, the maximum ambient temperature may have to be derated. Maximum ambient temperature [T<sub>A(MAX)</sub>] is dependent on the maximum operating junction temperature [T<sub>J(MAX)</sub>], the maximum power dissipation of the device in the application [P<sub>D(MAX)</sub>], and the junction-to-ambient thermal resistance of the part/package in the application (θ<sub>JA</sub>), as given by the following equation: T<sub>A(MAX)</sub> = T<sub>J(MAX)</sub> - (θ<sub>JA</sub> × P<sub>D(MAX)</sub>).
- (2) See the [Detailed Description](#) section.

### 7.4 Thermal Information

THERMAL METRIC <sup>(1)</sup>	TPS22810		UNIT	
	DBV (SOT23)	DRV (WSON)		
	6 PINS	6 PINS		
R <sub>θJA</sub>	Junction-to-ambient thermal resistance	182	74.6	°C/W
R <sub>θJC(top)</sub>	Junction-to-case (top) thermal resistance	127.2	80.3	°C/W
R <sub>θJB</sub>	Junction-to-board thermal resistance	16.9	44.3	°C/W
ψ <sub>JT</sub>	Junction-to-top characterization parameter	26.4	3.2	°C/W
ψ <sub>JB</sub>	Junction-to-board characterization parameter	36.3	44.6	°C/W

- (1) For more information about traditional and new thermal metrics, see the [Semiconductor and IC Package Thermal Metrics](#) application report.

## 7.5 Electrical Characteristics

Unless otherwise noted, the specification in the following table applies over the following ambient operating temperature  $-40^{\circ}\text{C} \leq T_A \leq +105^{\circ}\text{C}$ . Typical values are for  $T_A = 25^{\circ}\text{C}$ .

PARAMETER		TEST CONDITIONS	$T_A$	MIN	TYP	MAX	UNIT
$I_{Q, VIN}$	Quiescent current	$V = 18\text{ V}, I = 0\text{ A}$	$V_{IN} = 18\text{ V}$	$-40^{\circ}\text{C to }+85^{\circ}\text{C}$	62	80	$\mu\text{A}$
				$-40^{\circ}\text{C to }+105^{\circ}\text{C}$		85	
			$V_{IN} = 12\text{ V}$	$-40^{\circ}\text{C to }+85^{\circ}\text{C}$	62	80	
				$-40^{\circ}\text{C to }+105^{\circ}\text{C}$		85	
			$V_{IN} = 5\text{ V}$	$-40^{\circ}\text{C to }+85^{\circ}\text{C}$	59	80	
				$-40^{\circ}\text{C to }+105^{\circ}\text{C}$		85	
			$V_{IN} = 3.3\text{ V}$	$-40^{\circ}\text{C to }+85^{\circ}\text{C}$	53	80	
				$-40^{\circ}\text{C to }+105^{\circ}\text{C}$		85	
			$V_{IN} = 2.7\text{ V}$	$-40^{\circ}\text{C to }+85^{\circ}\text{C}$	49	70	
				$-40^{\circ}\text{C to }+105^{\circ}\text{C}$		85	
$I_{SD, VIN}$	Shutdown current	$V_{ON} = 0\text{ V}, V_{OUT} = 0\text{ V}$	$V_{IN} = 18\text{ V}$	$-40^{\circ}\text{C to }+85^{\circ}\text{C}$	0.5	2.3	$\mu\text{A}$
				$-40^{\circ}\text{C to }+105^{\circ}\text{C}$		3.8	
			$V_{IN} = 12\text{ V}$	$-40^{\circ}\text{C to }+85^{\circ}\text{C}$	0.5	2.3	
				$-40^{\circ}\text{C to }+105^{\circ}\text{C}$		3.8	
			$V_{IN} = 5\text{ V}$	$-40^{\circ}\text{C to }+85^{\circ}\text{C}$	0.5	2.3	
				$-40^{\circ}\text{C to }+105^{\circ}\text{C}$		3.8	
			$V_{IN} = 3.3\text{ V}$	$-40^{\circ}\text{C to }+85^{\circ}\text{C}$	0.5	2.3	
				$-40^{\circ}\text{C to }+105^{\circ}\text{C}$		3.8	
			$V_{IN} = 2.7\text{ V}$	$-40^{\circ}\text{C to }+85^{\circ}\text{C}$	0.5	2.3	
				$-40^{\circ}\text{C to }+105^{\circ}\text{C}$		3.8	
$I_{EN/UVLO}$	EN/UVLO pin input leakage current	$V_{IN} = 18\text{ V}, I_{OUT} = 0\text{ A}$	$-40^{\circ}\text{C to }+105^{\circ}\text{C}$			0.1	$\mu\text{A}$
$V_{UVR}$	VIN UVLO threshold, rising		$-40^{\circ}\text{C to }+105^{\circ}\text{C}$	2	2.54	2.62	V
$V_{UVhyst}$	VIN UVLO hysteresis		$-40^{\circ}\text{C to }+105^{\circ}\text{C}$		5%		
$V_{ENR}$	EN threshold voltage, rising		$-40^{\circ}\text{C to }+105^{\circ}\text{C}$	1.13	1.23	1.3	V
$V_{ENF}$	EN threshold voltage, falling		$-40^{\circ}\text{C to }+105^{\circ}\text{C}$	1.08	1.13	1.18	V
$V_{SHUTF}$	EN threshold voltage for low IQ shutdown		$-40^{\circ}\text{C to }+105^{\circ}\text{C}$	0.5	0.75	0.9	V

**Electrical Characteristics (continued)**

Unless otherwise noted, the specification in the following table applies over the following ambient operating temperature  $-40^{\circ}\text{C} \leq T_A \leq +105^{\circ}\text{C}$ . Typical values are for  $T_A = 25^{\circ}\text{C}$ .

PARAMETER		TEST CONDITIONS	$T_A$	MIN	TYP	MAX	UNIT	
$R_{ON}$	On-resistance	$V_{IN} = 18\text{ V}, I_{OUT} = -200\text{ mA}$	25°C		79	86	mΩ	
			-40°C to +85°C			105		
			-40°C to +105°C			115		
		$V_{IN} = 12\text{ V}, I_{OUT} = -200\text{ mA}$	25°C		79	86		
			-40°C to +85°C			105		
			-40°C to +105°C			115		
		$V_{IN} = 9\text{ V}, I_{OUT} = -200\text{ mA}$	25°C		79	86		
			-40°C to +85°C			105		
			-40°C to +105°C			115		
		$V_{IN} = 5\text{ V}, I_{OUT} = -200\text{ mA}$	25°C		79	86		
			-40°C to +85°C			105		
			-40°C to +105°C			115		
		$V_{IN} = 3.3\text{ V}, I_{OUT} = -200\text{ mA}$	25°C		83	92		
			-40°C to +85°C			115		
			-40°C to +105°C			125		
$V_{IN} = 2.7\text{ V}, I_{OUT} = -200\text{ mA}$	25°C		86	95				
	-40°C to +85°C			120				
	-40°C to +105°C			130				
$R_{PD}$	Output pull down resistance	$V_{IN} = V_{OUT} = 18\text{ V}, V_{EN/UVLO} = 0\text{ V}$	-40°C to +105°C		290	350	Ω	
			$V_{IN} = V_{OUT} = 12\text{ V}, V_{EN/UVLO} = 0\text{ V}$	-40°C to +105°C		265		350
			$V_{IN} = V_{OUT} = 5\text{ V}, V_{EN/UVLO} = 0\text{ V}$	-40°C to +105°C		250		400
TS	Thermal shutdown	Threshold, $V_{IN} = 18\text{ V}$	-40°C to +105°C		160		°C	
TSHDN Hyst	Thermal shutdown hysteresis	TSD hysteresis, $V_{IN} = 18\text{ V}$	-40°C to +105°C		30		°C	

## 7.6 Switching Characteristics

Refer to the timing test circuit in [Figure 16](#) (unless otherwise noted) for references to external components used for the test condition in the switching characteristics table. Switching characteristics shown below are only valid for the power-up sequence where VIN is already in steady state condition before the EN/UVLO pin is asserted high.

PARAMETER		TEST CONDITIONS	MIN	TYP	MAX	UNIT
<b>V<sub>IN</sub> = 18 V, V<sub>EN/UVLO</sub> = 5 V, T<sub>A</sub> = 25 °C (unless otherwise noted)</b>						
t <sub>ON</sub>	Turnon time	R <sub>L</sub> = 10 Ω, C <sub>IN</sub> = 1 μF, C <sub>L</sub> = 0.1 μF, CT = 2200 pF		520		μs
t <sub>OFF</sub>	Turnoff time	R <sub>L</sub> = 10 Ω, C <sub>IN</sub> = 1 μF, C <sub>L</sub> = 0.1 μF, CT = 2200 pF		3.3		
t <sub>R</sub>	V <sub>OUT</sub> rise time	R <sub>L</sub> = 10 Ω, C <sub>IN</sub> = 1 μF, C <sub>L</sub> = 0.1 μF, CT = 2200 pF		700		
t <sub>F</sub>	V <sub>OUT</sub> fall time	R <sub>L</sub> = 10 Ω, C <sub>IN</sub> = 1 μF, C <sub>L</sub> = 0.1 μF, CT = 2200 pF		2		
t <sub>D</sub>	Delay time	R <sub>L</sub> = 10 Ω, C <sub>IN</sub> = 1 μF, C <sub>L</sub> = 0.1 μF, CT = 2200 pF		180		
<b>V<sub>IN</sub> = 12 V, V<sub>EN/UVLO</sub> = 5 V, T<sub>A</sub> = 25 °C (unless otherwise noted)</b>						
t <sub>ON</sub>	Turnon time	R <sub>L</sub> = 10 Ω, C <sub>IN</sub> = 1 μF, C <sub>L</sub> = 0.1 μF, CT = 2200 pF		380		μs
t <sub>OFF</sub>	Turnoff time	R <sub>L</sub> = 10 Ω, C <sub>IN</sub> = 1 μF, C <sub>L</sub> = 0.1 μF, CT = 2200 pF		3.3		
t <sub>R</sub>	V <sub>OUT</sub> rise time	R <sub>L</sub> = 10 Ω, C <sub>IN</sub> = 1 μF, C <sub>L</sub> = 0.1 μF, CT = 2200 pF		460		
t <sub>F</sub>	V <sub>OUT</sub> fall time	R <sub>L</sub> = 10 Ω, C <sub>IN</sub> = 1 μF, C <sub>L</sub> = 0.1 μF, CT = 2200 pF		2		
t <sub>D</sub>	ON delay time	R <sub>L</sub> = 10 Ω, C <sub>IN</sub> = 1 μF, C <sub>L</sub> = 0.1 μF, CT = 2200 pF		150		
<b>V<sub>IN</sub> = 3.3 V, V<sub>EN/UVLO</sub> = 5 V, T<sub>A</sub> = 25 °C (unless otherwise noted)</b>						
t <sub>ON</sub>	Turnon time	R <sub>L</sub> = 10 Ω, C <sub>IN</sub> = 1 μF, C <sub>L</sub> = 0.1 μF, CT = 2200 pF		185		μs
t <sub>OFF</sub>	Turnoff time	R <sub>L</sub> = 10 Ω, C <sub>IN</sub> = 1 μF, C <sub>L</sub> = 0.1 μF, CT = 2200 pF		3.3		
t <sub>R</sub>	V <sub>OUT</sub> rise time	R <sub>L</sub> = 10 Ω, C <sub>IN</sub> = 1 μF, C <sub>L</sub> = 0.1 μF, CT = 2200 pF		120		
t <sub>F</sub>	V <sub>OUT</sub> fall time	R <sub>L</sub> = 10 Ω, C <sub>IN</sub> = 1 μF, C <sub>L</sub> = 0.1 μF, CT = 2200 pF		2		
t <sub>D</sub>	ON delay time	R <sub>L</sub> = 10 Ω, C <sub>IN</sub> = 1 μF, C <sub>L</sub> = 0.1 μF, CT = 2200 pF		130		

### 7.7 Typical DC Characteristics

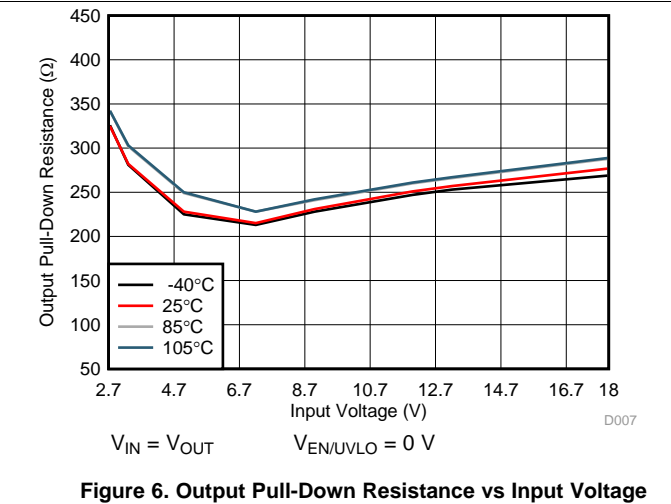
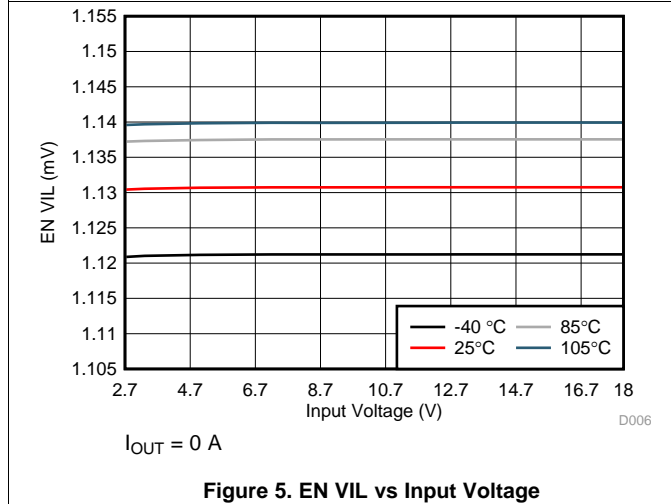
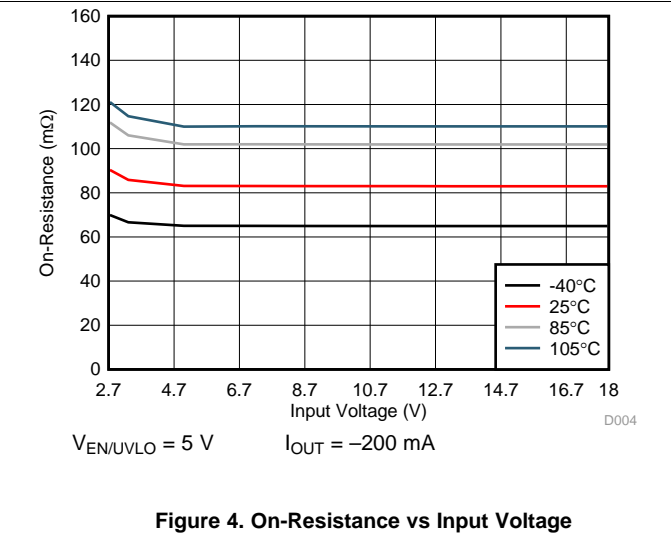
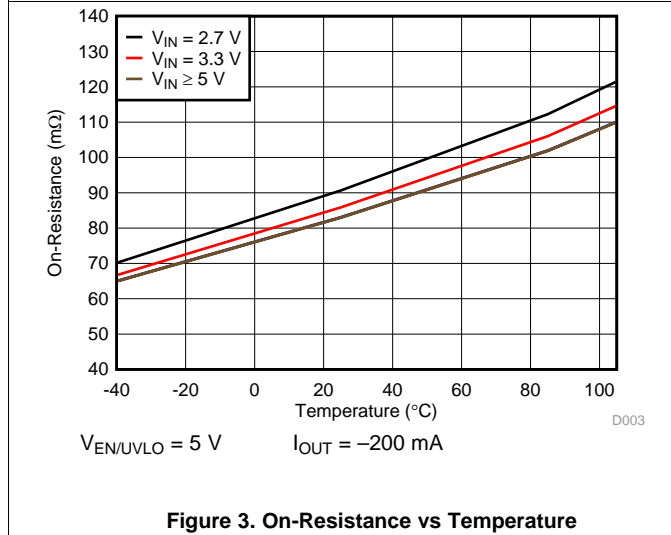
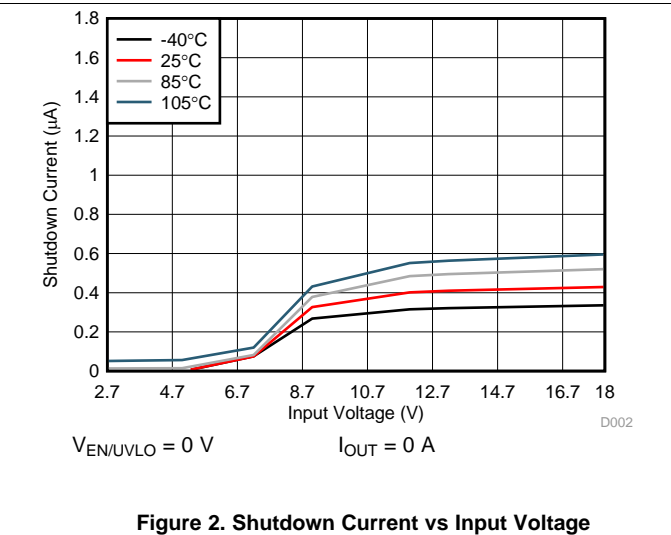
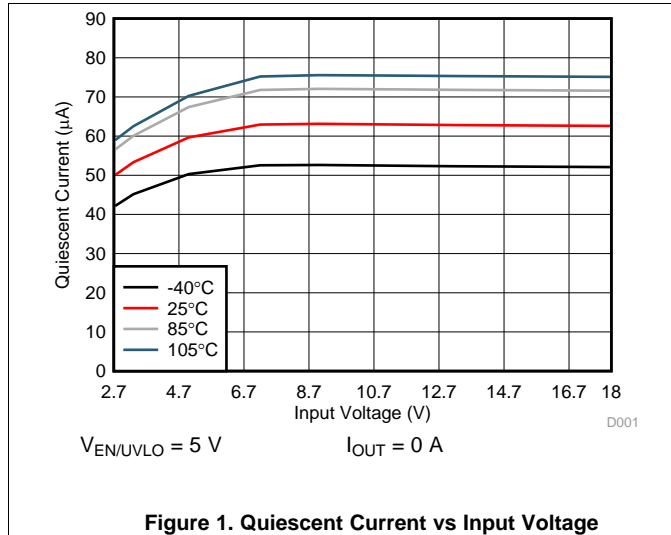



### 7.8 Typical AC Characteristics

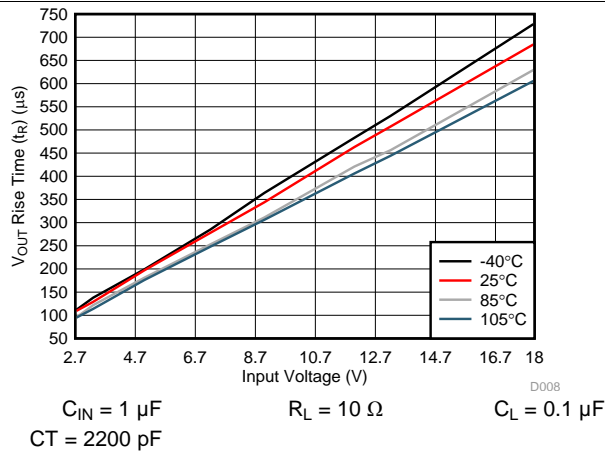

Figure 7.  $V_{OUT}$  Rise Time ( $t_R$ ) vs Input Voltage

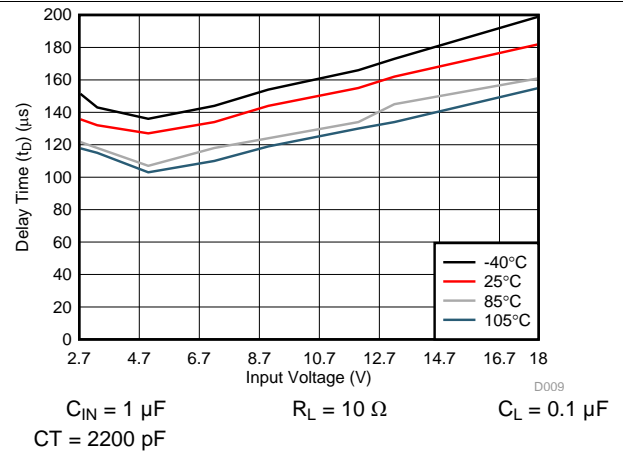

Figure 8. Delay Time ( $t_D$ ) vs Input Voltage

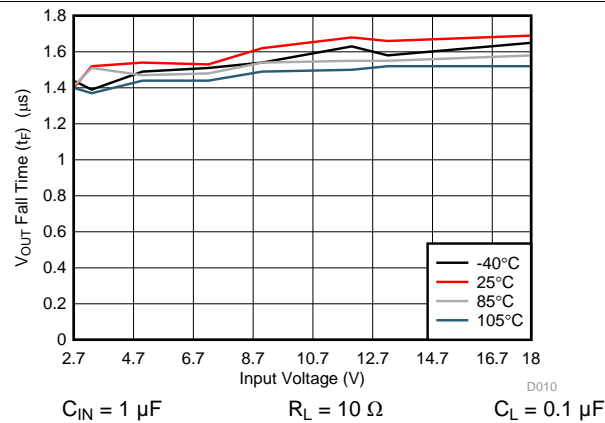

Figure 9.  $V_{OUT}$  Fall Time ( $t_F$ ) vs Input Voltage

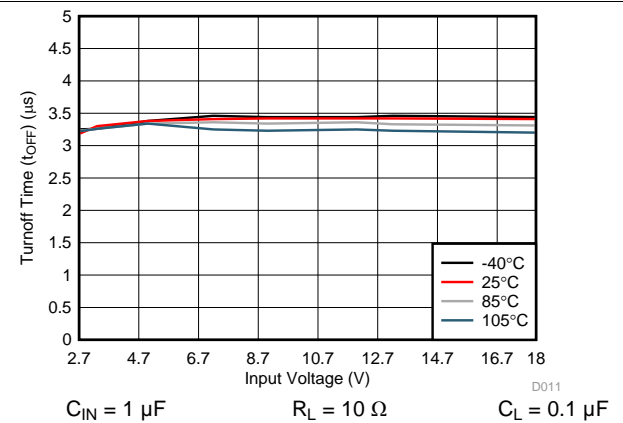

Figure 10. Turnoff Time ( $t_{OFF}$ ) vs Input Voltage

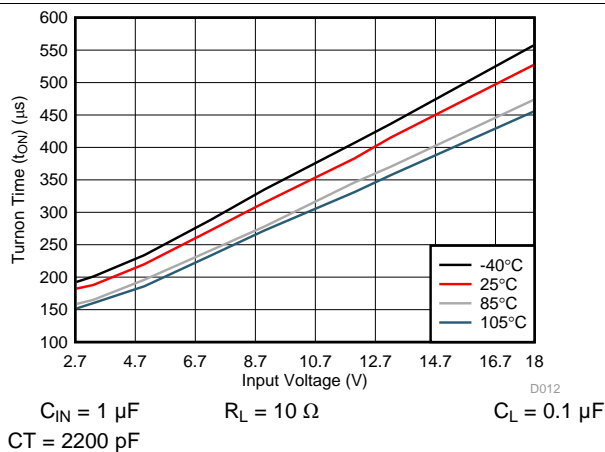

Figure 11. Turnon Time ( $t_{ON}$ ) vs Input Voltage

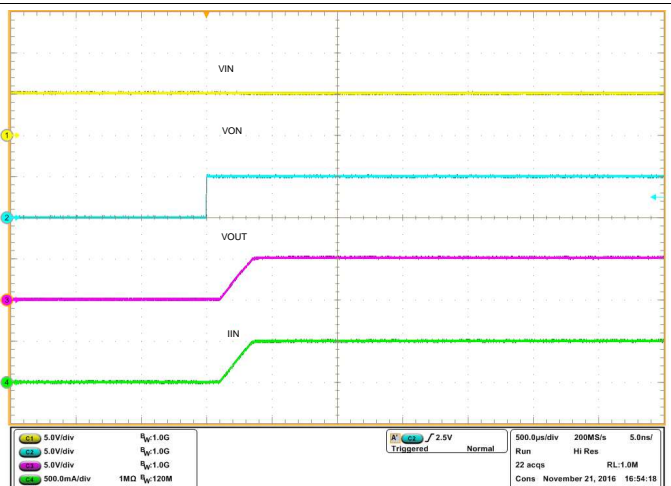
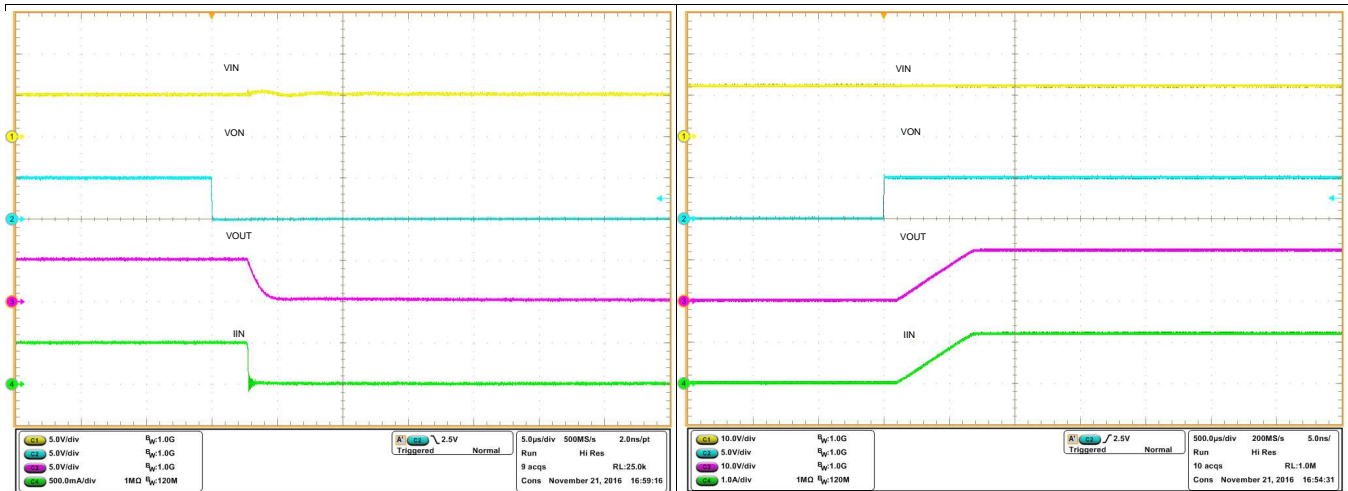

Figure 12. Rise Time  $t_R$  at  $V_{IN} = 5\text{ V}$

Typical AC Characteristics (continued)



$V_{IN} = 5\text{ V}$        $C_{IN} = 1\ \mu\text{F}$        $C_L = 0.1\ \mu\text{F}$   
 $R_L = 10\ \Omega$       QOD = Open

Figure 13. Fall Time  $t_F$  at  $V_{IN} = 5\text{ V}$

$V_{IN} = 12\text{ V}$        $C_{IN} = 1\ \mu\text{F}$        $C_L = 0.1\ \mu\text{F}$   
 $R_L = 10\ \Omega$       CT = 2200 pF

Figure 14. Rise Time  $t_R$  at  $V_{IN} = 12\text{ V}$

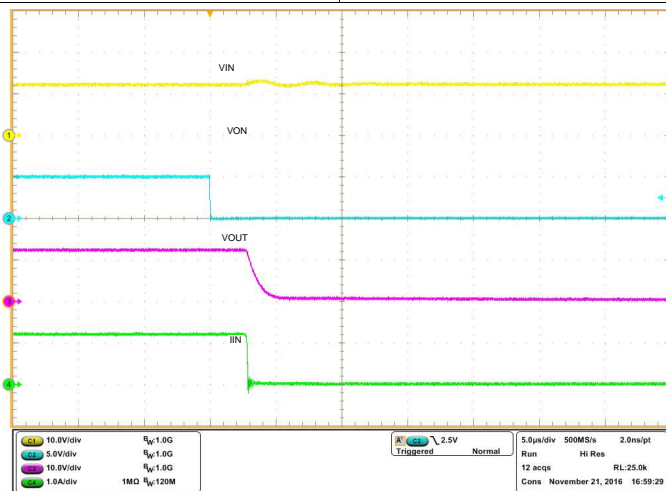

$V_{IN} = 12\text{ V}$        $C_{IN} = 1\ \mu\text{F}$        $C_L = 0.1\ \mu\text{F}$   
 $R_L = 10\ \Omega$       QOD = Open

Figure 15. Fall Time  $t_F$  at  $V_{IN} = 12\text{ V}$

## 8 Parameter Measurement Information

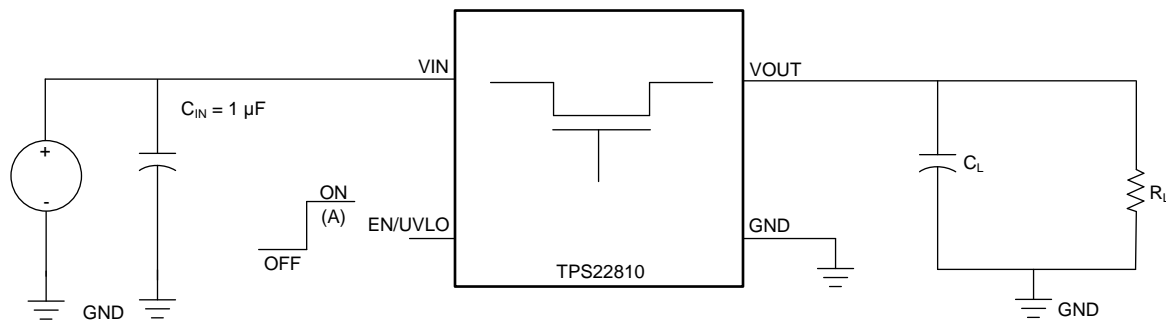

A. Rise and fall times of the control signal are 100 ns

**Figure 16. Test Circuit**

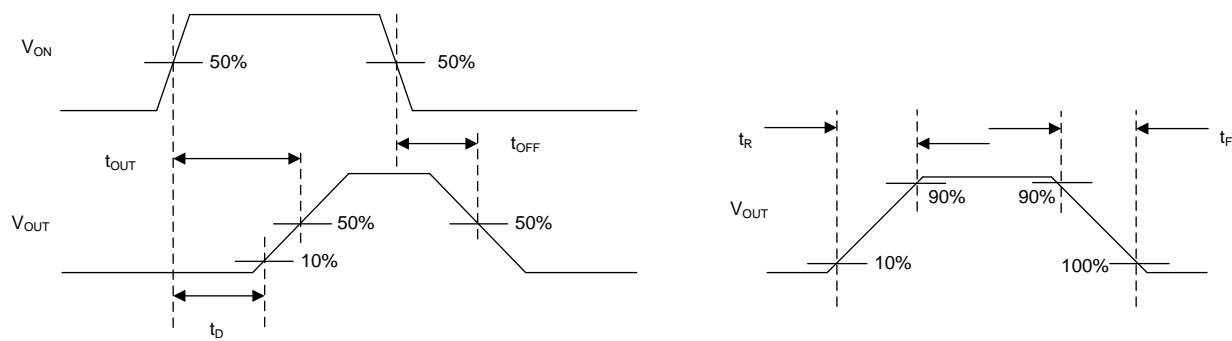

**Figure 17. Timing Waveforms**

## 9 Detailed Description

### 9.1 Overview

The TPS22810 is a 6-pin, 2.7-18-V load switch with thermal protection in two separate package options. To reduce voltage drop for low voltage and high current rails, the device implements a low resistance N-channel MOSFET which reduces the drop out voltage across the device.

The device starts its operation by monitoring the VIN bus. When VIN exceeds the undervoltage-lockout threshold (VUVR), the device samples the EN/UVLO pin. A high level on this pin enables the internal MOSFET. As VIN rises, the internal MOSFET of the device starts conducting and allow current to flow from VIN to VOUT. When EN/UVLO is held low (below VENF), internal MOSFET is turned off.

A voltage  $V(\text{EN/UVLO}) < V(\text{ENF})$  on this pin turns off the internal FET, thus disconnecting VIN from VOUT, while voltage below  $V(\text{SHUTF})$  takes the device into shutdown mode, with IQ less than 1  $\mu\text{A}$  to ensure minimal power loss.

The device has a configurable slew rate which helps reduce or eliminate power supply droop because of large inrush currents. The device also features an internal RPD resistor, which discharges VOUT once the switch is disabled.

During shutdown, the device has very low leakage currents, thereby reducing unnecessary leakages for downstream modules during standby. Integrated control logic, driver, charge pump, and output discharge FET eliminates the need for any external components which reduces solution size and bill of materials (BOM) count.

The device also features a QOD pin, which allows the configuration of the discharge rate of VOUT once the switch is disabled.

The device has a thermal protection feature. Due to this device protects itself against thermal damage due to over-temperature and over-current conditions. Safe Operating Area (SoA) requirements are thus inherently met without any special design consideration by the board designer.

## 9.2 Functional Block Diagram

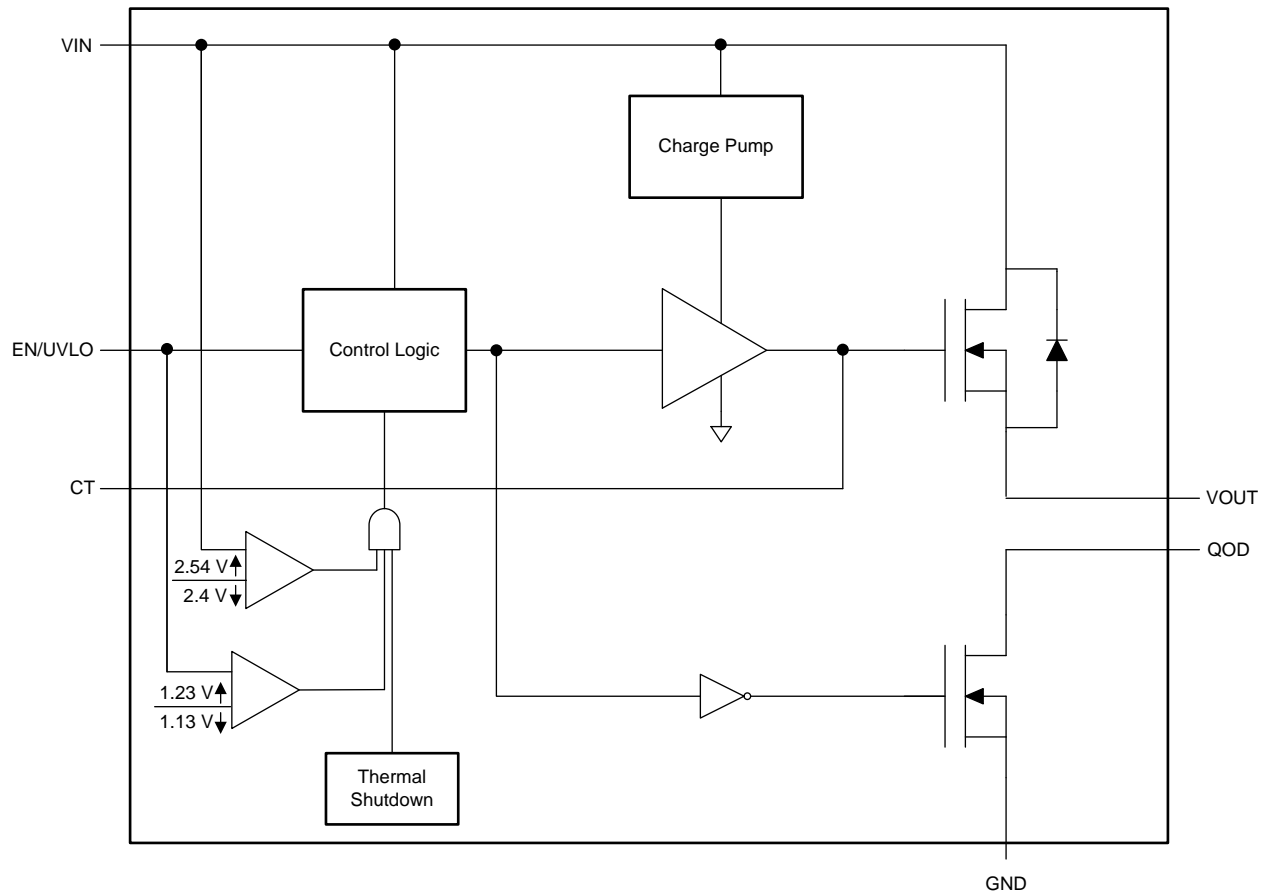

Copyright © 2016, Texas Instruments Incorporated

## 9.3 Feature Description

### 9.3.1 On and Off Control

The EN/UVLO pin controls the state of the switch. EN/UVLO is active high and has a low threshold, making it capable of interfacing with low-voltage signals. The EN/UVLO pin is compatible with standard GPIO logic threshold. It can be used with any microcontroller with 1.2 V or higher GPIO voltage. This pin cannot be left floating and must be driven either high or low for proper functionality.

### 9.3.2 Quick Output Discharge (QOD)

The TPS22810 includes a QOD feature. The QOD pin can be configured in one of three ways:

- QOD pin shorted to VOUT pin. Using this method, the discharge rate after the switch becomes disabled is controlled with the value of the internal resistance  $R_{PD}$ . The value of this resistance is listed in the [Electrical Characteristics](#) table.
- QOD pin connected to VOUT pin using an external resistor  $R_{EXT}$ . After the switch becomes disabled, the discharge rate is controlled by the value of the total resistance of the QOD. To adjust the total QOD resistance, [Equation 1](#) can be used.

$$R_{QOD} = R_{PD} + R_{EXT}$$

where

- $R_{QOD}$  is the total output discharge resistance
- $R_{PD}$  is the internal pulldown resistance
- $R_{EXT}$  is the external resistance placed between the VOUT and QOD pin.

(1)

## Feature Description (continued)

- QOD pin is unused and left floating. Using this method, there is no quick output discharge functionality, and the output remains floating after the switch is disabled.

Note that during thermal shutdown, the QOD functionality is not available. The device does not discharge the load as RPD does not become engaged.

The fall times of the device depend on many factors including the total resistance of the QOD,  $V_{IN}$ , and the output capacitance. When QOD is connected to VOUT, the fall time changes over  $V_{IN}$  as the internal  $R_{PD}$  varies over  $V_{IN}$ . To calculate the approximate fall time of  $V_{OUT}$  for a given  $R_{QOD}$ , use Equation 2 and Table 1.

$$V_{CAP} = V_{IN} \times e^{-t/\tau}$$

where

- $V_{CAP}$  is the voltage across the capacitor (V)
  - $t$  is the time since power supply removal (s)
  - $\tau$  is the time constant equal to  $R_{QOD} \times C_L$
- (2)

The fall times' dependency on  $V_{IN}$  becomes minimal as the QOD value increases with additional external resistance. See Table 1 for QOD fall times.

**Table 1. QOD Fall Times**

$V_{IN}$ (V)	FALL TIME ( $\mu$ s) 90% - 10%, $C_{IN} = 1 \mu$ F, $I_{OUT} = 0$ A, $V_{IN} = 0$ V, ON = 0 V <sup>(1)</sup>					
	$T_A = 25^\circ$ C			$T_A = 85^\circ$ C		
	$C_L = 1 \mu$ F	$C_L = 10 \mu$ F	$C_L = 100 \mu$ F	$C_L = 1 \mu$ F	$C_L = 10 \mu$ F	$C_L = 100 \mu$ F
18	470	4700	47000	470	4700	47000
12	450	4500	45000	450	4500	45000
9	440	4400	44000	440	4400	44000
5	500	5000	50000	480	4800	48000
3.3	600	6000	60000	570	5700	57000

(1) TYPICAL VALUES WITH QOD SHORTED TO VOUT

### 9.3.2.1 QOD when System Power is Removed

The adjustable QOD can be used to control the power down sequencing of a system even when the system power supply is removed. When the power is removed, the input capacitor,  $C_{IN}$ , discharges at  $V_{IN}$ . Past the set UVLO level, the pull-down resistance RPD becomes disabled and the output no longer becomes discharged. If there is still remaining charge on the output capacitor, this results in longer fall times. Care must be taken such that  $C_{IN}$  is large enough to meet the device UVLO settings.

### 9.3.2.2 Internal QOD Considerations

Special considerations must be taken when using the internal  $R_{PD}$  by shorting the QOD pin to the VOUT pin. The internal  $R_{PD}$  is a pulldown resistance designed to quickly discharge a load after the switch has been disabled. Care must be used to ensure that excessive current does not flow through  $R_{PD}$  during discharge so that the maximum  $T_J$  of  $125^\circ$ C is not exceeded. When using only the internal  $R_{PD}$  to discharge a load, the total capacitive load must not exceed 200  $\mu$ F. Otherwise, an external resistor,  $R_{EXT}$ , must be used to ensure the amount of current flowing through  $R_{PD}$  is properly limited and the maximum  $T_J$  is not exceeded. To ensure the device is not damaged, the remaining charge from  $C_L$  needs to decay naturally through the internal QOD resistance and must not be driven.

### 9.3.3 EN/UVLO

As an input pin, EN/UVLO controls the ON and OFF state of the internal MOSFET. In its high state, the internal MOSFET is enabled. A low on this pin turns off the internal MOSFET. High and Low levels are specified in the parametric table of the datasheet

A voltage  $V(EN/UVLO < V(ENF))$  on this pin turns off the internal FET, thus disconnecting  $V_{IN}$  from  $V_{OUT}$ , while voltage below  $V(SHUTF)$  takes the device into shutdown mode, with  $I_Q$  less than 1  $\mu$ A to ensure minimal power loss.

The EN/UVLO pin can be directly driven by a 1.8 V, 3.3 V or 5 V general purpose output pin.

The internal de-glitch delay on EN/UVLO falling edge is intentionally kept low (2.5  $\mu$ s typical) for quick detection of power failure. For applications where a higher de-glitch delay on EN/UVLO is desired, or when the supply is particularly noisy, it is recommended to use an external bypass capacitor from EN/UVLO to GND.

The undervoltage lock out can be programmed by using an external resistor divider from supply VIN terminal to EN/UVLO terminal to GND as shown in Figure 18. When an undervoltage or input power fail event is detected, the internal FET is quickly turned off. If the Under-Voltage Lock-Out function is not needed, the EN/UVLO terminal must be connected to the VIN terminal. EN/UVLO terminal must not be left floating.

The device also implements internal undervoltage-lockout (UVLO) circuitry on the VIN terminal. The device disables when the VIN terminal voltage falls below internal UVLO Threshold V(UVF). The internal UVLO threshold has a hysteresis of 125 mV (5% of V(UVR)). See Figure 19 and Figure 20.

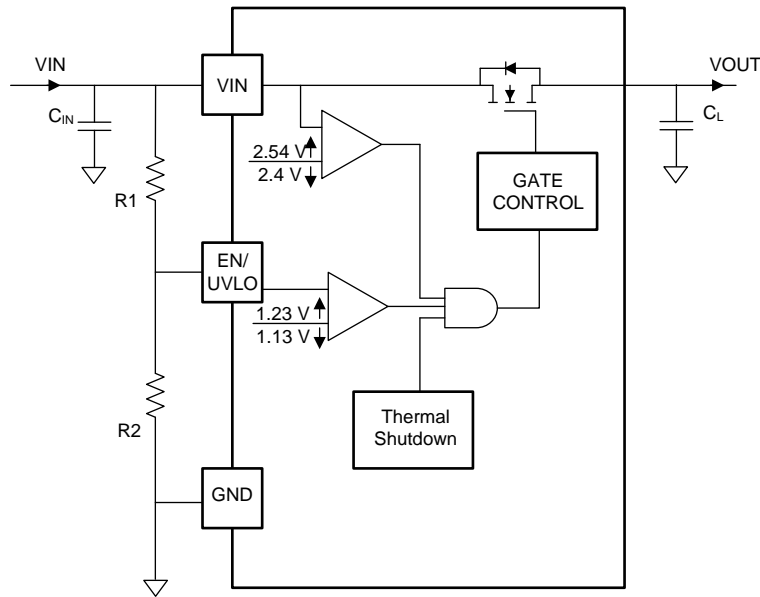

Copyright © 2016, Texas Instruments Incorporated

Figure 18. Configuring UVLO with External Resistor Network

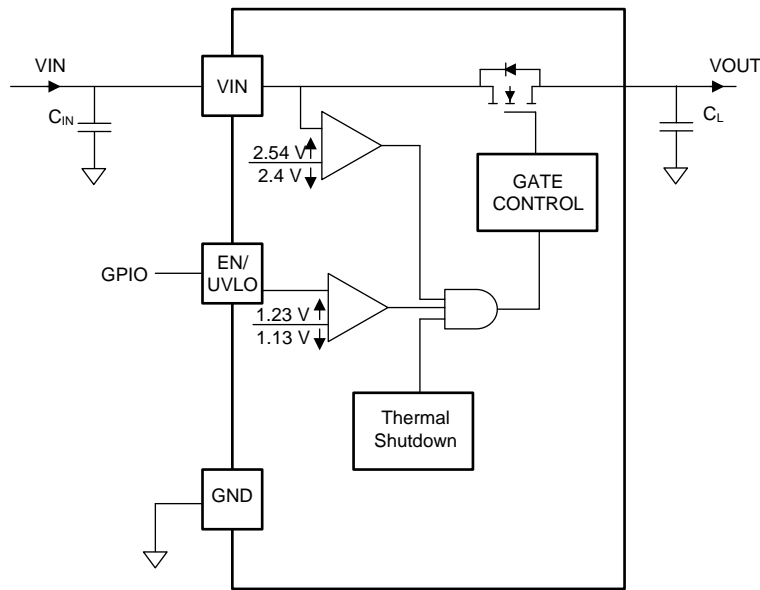

Copyright © 2016, Texas Instruments Incorporated

Figure 19. Using 1.8 V/3.3 V GPIO Signal Directly from Processor

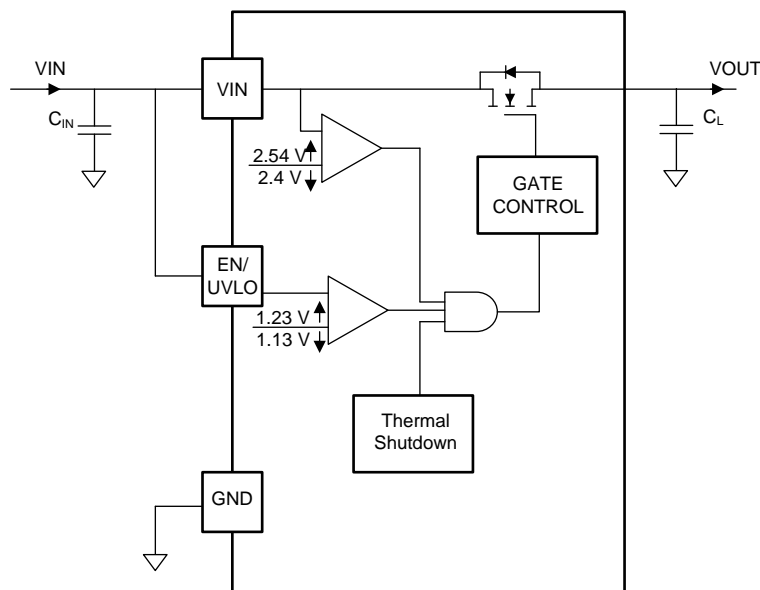

Copyright © 2016, Texas Instruments Incorporated

Figure 20. Default UVLO Threshold V(UVR) Using No Additional External Components

### 9.3.4 Adjustable Rise Time (CT)

A capacitor to GND on the CT pin sets the slew rate. The voltage on the CT pin can be as high as 2.5 V. An approximate formula for the relationship between CT and slew rate is shown in Equation 3. This equation accounts for 10% to 90% measurement on VOUT and does NOT apply for CT < 1 nF.

Use Table 2 to determine rise times for when Ct ≥ 1 nF.

$$SR = 46.62 / Ct$$

where

- SR is the slew rate (in V/μs)



- CT is the the capacitance value on the CT pin (in pF)
- The units for the constant a are  $\mu\text{s}/\text{V}$ . The units for the constant b are  $\mu\text{s}/(\text{V} \times \text{pF})$ . (3)

Rise time can be calculated by dividing the input voltage by the slew rate. [Table 2](#) contains rise time values measured on a typical device. Rise times shown below are only valid for the power-up sequence where VIN is already in steady state condition before the EN/UVLO pin is asserted high.

**Table 2. Rise Time Table**

CT (pF)	RISE TIME ( $\mu\text{s}$ ) 10% - 90%, $C_L = 0.1 \mu\text{F}$ , $C_{IN} = 1 \mu\text{F}$ , $R_L = 10 \Omega$				
	VIN = 18 V	VIN = 12 V	VIN = 9 V	VIN = 5 V	VIN = 3.3 V
0	115	91	78	60	98
470	136	94	80	63	98
1000	310	209	158	91	102
2200	688	464	345	198	135
4700	1430	957	704	397	265
10000	3115	2085	1540	864	550
27000	8230	5460	4010	2245	1430

### 9.3.5 Thermal Shutdown

The switch disables when the junction temperature ( $T_J$ ) rises above the thermal shutdown threshold,  $T_{SD}$ . The switch re-enables once the temperature drops below the  $T_{SD} - T_{SD,HYS}$  value.

### 9.4 Device Functional Modes

The features of the TPS22810 depend on the operating mode. [Table 3](#) summarizes the Device Functional Modes.

**Table 3. Function Table**

EN/UVLO	Device State
L	Disabled
H	Enabled

## 10 Application and Implementation

### NOTE

Information in the following applications sections is not part of the TI component specification, and TI does not warrant its accuracy or completeness. TI's customers are responsible for determining suitability of components for their purposes. Customers should validate and test their design implementation to confirm system functionality.

### 10.1 Application Information

This section highlights some of the design considerations when implementing this device in various applications. A PSPICE model for this device is also available in the product page of this device on [www.ti.com](http://www.ti.com) (See the [器件支持](#) section for more information).

### 10.2 ON and OFF Control

The EN/UVLO pin controls the state of the switch. Asserting EN/UVLO high enables the switch. EN/UVLO is active high and has a low threshold, making it capable of interfacing with low-voltage signals. The EN/UVLO pin is compatible with standard GPIO logic thresholds. It can be used with any microcontroller with 1.2 V or higher GPIO voltage. This pin cannot be left floating and must be driven either high or low for proper functionality.

### 10.3 Input Capacitor (Optional)

To limit the voltage drop on the input supply caused by transient inrush currents when the switch turns on into a discharged load capacitor, a capacitor needs to be placed between VIN and GND. A 1- $\mu$ F ceramic capacitor,  $C_{IN}$ , placed close to the pins, is usually sufficient. Higher values of  $C_{IN}$  can be used to further reduce the voltage drop during high current applications. When switching heavy loads, it is recommended to have an input capacitor about 10 times higher than the output capacitor to avoid excessive voltage drop.

### 10.4 Output Capacitor (Optional)

Due to the integrated body diode in the NMOS switch, a  $C_{IN}$  greater than  $C_L$  is highly recommended. A  $C_L$  greater than  $C_{IN}$  can cause VOUT to exceed VIN when the system supply is removed. This can result in current flow through the body diode from VOUT to VIN. A  $C_{IN}$  to  $C_L$  ratio of 10 to 1 is recommended for minimizing VIN dip caused by inrush currents during startup; however, a 10 to 1 ratio for capacitance is not required for proper functionality of the device. A ratio smaller than 10 to 1 (such as 1 to 1) can cause slightly more VIN dip upon turnon due to inrush currents.

This can be mitigated by increasing the capacitance on the CT pin for a longer rise time.

### 10.5 Typical Application

This typical application demonstrates how the TPS22810 can be used to power downstream modules.

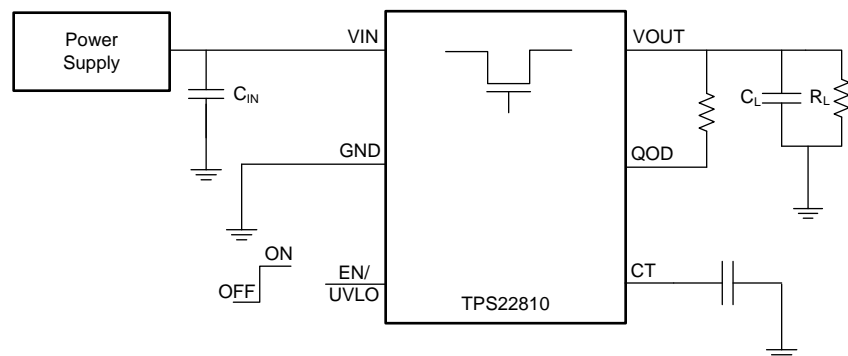

Copyright © 2016, Texas Instruments Incorporated

**Figure 21. Typical Application Schematic**

## Typical Application (continued)

### 10.5.1 Design Requirements

For this design example, use the values listed in [Table 4](#) as the design parameters:

**Table 4. Design Parameters**

DESIGN PARAMETER	EXAMPLE VALUE
$V_{IN}$	12 V
Load current	2 A
$C_L$	22 $\mu$ F
Desired fall time	20 ms
Maximum acceptable inrush current	400 mA

### 10.5.2 Detailed Design Procedure

#### 10.5.2.1 Shutdown Sequencing During Unexpected Power Loss

Using the adjustable Quick Output Discharge function of the TPS22810, adding a load switch to each power rail can be used to manage the power down sequencing in the event of an unexpected power loss (that is battery removal). To determine the QOD values for each load switch, first confirm the power down order of the device you wish to power sequence. Be sure to check if there are voltage or timing margins that must be maintained during power down. Next, consult [Table 1](#) to determine appropriate  $C_L$  and  $R_{QOD}$  values for each power rail's load switch so that the load switches' fall times correspond to the order in which they need to be powered down. In the above example, we must have this power rail's fall time to be 4 ms. Using [Equation 2](#), we can determine the appropriate  $R_{QOD}$  to achieve our desired fall time.

Since fall times are measured from 90% of  $V_{OUT}$  to 10% of  $V_{OUT}$ , using [Equation 2](#), we get [Equation 4](#) and [Equation 5](#).

$$1.2V = 10.8V \times e^{-(20ms)/(R_{QOD} \times (22\mu F))} \quad (4)$$

$$R_{QOD} = 413.7 \Omega \quad (5)$$

Consulting [Figure 6](#),  $R_{PD}$  at  $V_{IN} = 12$  V is approximately 250  $\Omega$ . Using [Equation 1](#), the required external QOD resistance can be calculated as shown in [Equation 6](#) and [Equation 7](#).

$$413.7 \Omega = 250 \Omega + R_{EXT} \quad (6)$$

$$R_{EXT} = 163.7 \Omega \quad (7)$$

[Figure 22](#) through [Figure 25](#) are scope shots demonstrating an example of the QOD functionality when power is removed from the device (both ON and  $V_{IN}$  are disconnected simultaneously). In the scope shots, the  $V_{IN} = 12$  V and correspond to when  $R_{QOD} = 1000 \Omega$ ,  $R_{QOD} = 500 \Omega$ , and  $QOD = V_{OUT}$  with two values of  $C_L = 10 \mu$ F and 22  $\mu$ F.

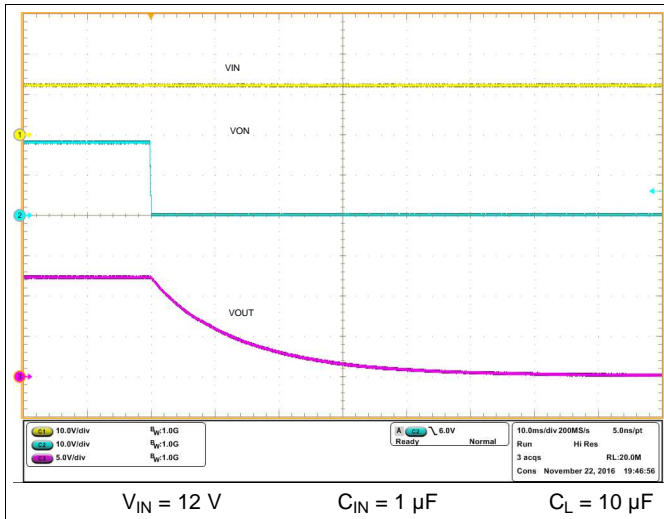

Figure 22. Fall Time  $t_F$  at  $V_{IN} = 12\text{ V}$ ,  $R_{QOD} = 1000\ \Omega$

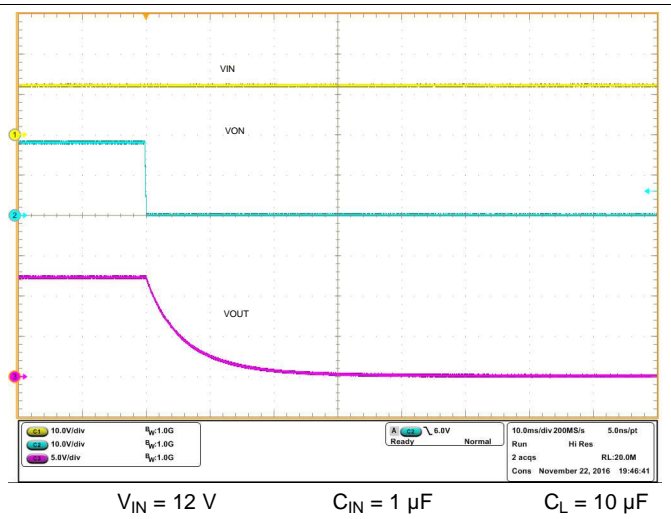

Figure 23. Fall Time  $t_F$  at  $V_{IN} = 12\text{ V}$ ,  $R_{QOD} = 500\ \Omega$

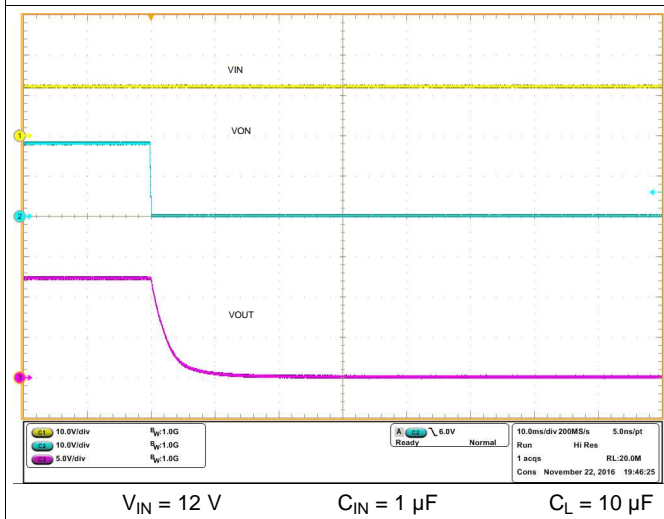

Figure 24.  $t_F$  at  $V_{IN} = 12\text{ V}$ ,  $QOD = V_{OUT}$

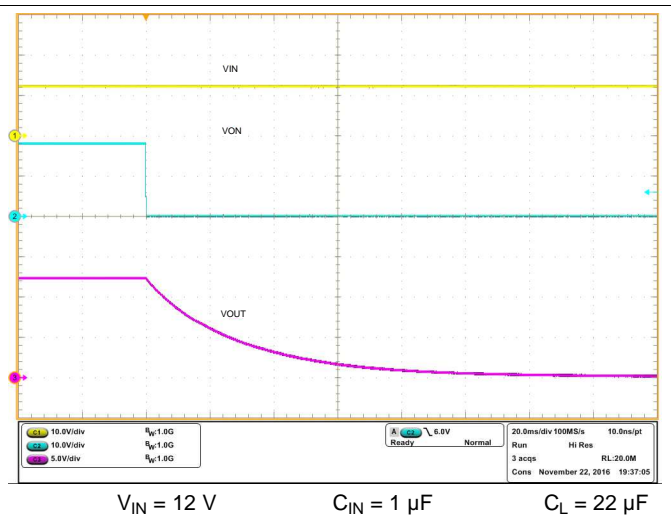

Figure 25.  $t_F$  at  $V_{IN} = 12\text{ V}$ ,  $R_{QOD} = 1000\ \Omega$

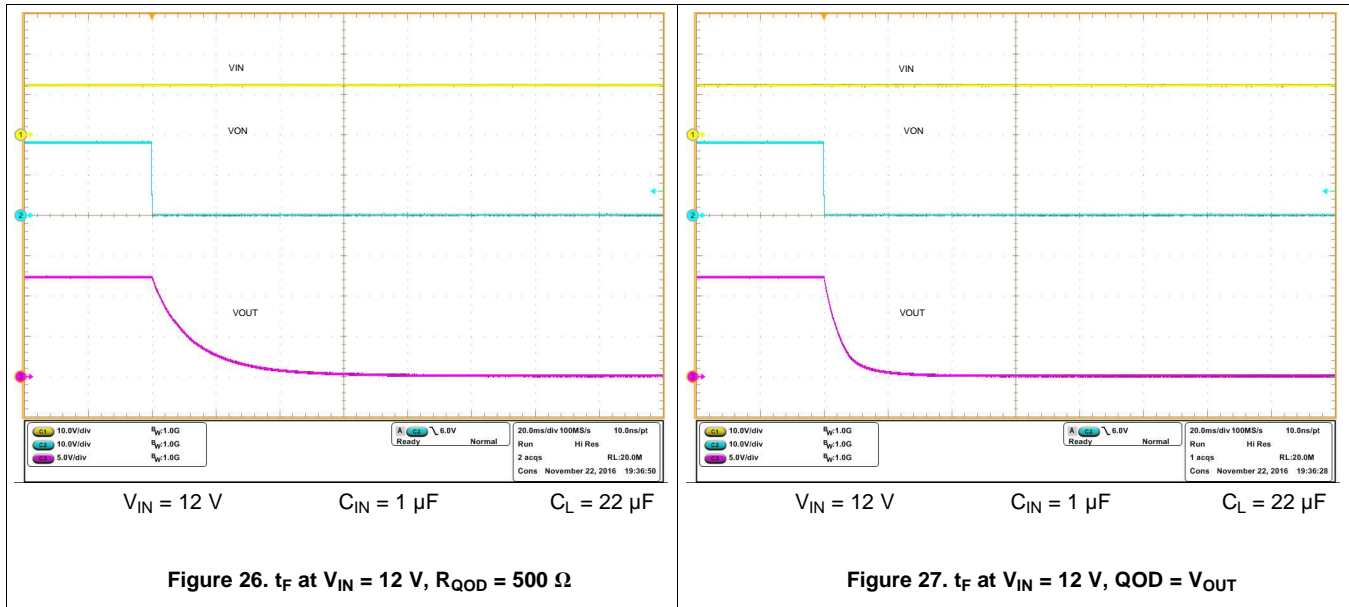

Figure 26.  $t_F$  at  $V_{IN} = 12\text{ V}$ ,  $R_{QOD} = 500\ \Omega$

Figure 27.  $t_F$  at  $V_{IN} = 12\text{ V}$ ,  $Q_{OD} = V_{OUT}$

### 10.5.2.2 VIN to VOUT Voltage Drop

The  $V_{IN}$  to  $V_{OUT}$  voltage drop in the device is determined by the  $R_{ON}$  of the device and the load current. The  $R_{ON}$  of the device depends upon the  $V_{IN}$  conditions of the device. Refer to the  $R_{ON}$  specification of the device in the [Electrical Characteristics](#) table of this datasheet. Once the  $R_{ON}$  of the device is determined based upon the  $V_{IN}$  conditions, use [Equation 8](#) to calculate the  $V_{IN}$  to  $V_{OUT}$  voltage drop.

$$\Delta V = I_{LOAD} \times R_{ON}$$

where

- $\Delta V$  is the voltage drop from  $V_{IN}$  to  $V_{OUT}$
- $I_{LOAD}$  is the load current
- $R_{ON}$  is the On-resistance of the device for a specific  $V_{IN}$

(8)

An appropriate  $I_{LOAD}$  must be chosen such that the  $I_{MAX}$  specification of the device is not violated.

### 10.5.2.3 Inrush Current

To determine how much inrush current is caused by the  $C_L$  capacitor, use [Equation 9](#).

$$I_{INRUSH} = C_L \times \frac{dV_{OUT}}{dt}$$

where

- $I_{INRUSH}$  is the amount of inrush caused by  $C_L$
- $C_L$  is the capacitance on  $V_{OUT}$
- $dt$  is the Output Voltage rise time during the ramp up of  $V_{OUT}$  when the device is enabled
- $dV_{OUT}$  is the change in  $V_{OUT}$  during the ramp up of  $V_{OUT}$  when the device is enabled

(9)

The appropriate rise time can be calculated using the design requirements and the inrush current equation. As we calculate the rise time (measured from 10% to 90% of  $V_{OUT}$ ), we account for this in our  $dV_{OUT}$  parameter (80% of  $V_{OUT} = 9.6\text{ V}$ ) as shown in [Equation 10](#) and [Equation 11](#).

$$400\text{ mA} = 22\ \mu\text{F} \times 9.6\text{ V}/dt \tag{10}$$

$$dt = 528\ \mu\text{s} \tag{11}$$

To ensure an inrush current of less than 400 mA, choose a CT value that yields a rise time of more than 528  $\mu\text{s}$ . Consulting [Table 2](#) at  $V_{IN} = 12\text{ V}$ ,  $CT = 4700\text{ pF}$  provides a typical rise time of 957  $\mu\text{s}$ . Using this rise time and voltage into [Equation 9](#), yields [Equation 12](#) and [Equation 13](#).

$$I_{Inrush} = 22\ \mu\text{F} \times 9.6\text{ V}/957\ \mu\text{s} \tag{12}$$

$$I_{Inrush} = 220\text{ mA} \tag{13}$$

An appropriate  $C_L$  value must be placed on VOUT such that the  $I_{MAX}$  and  $I_{PLS}$  specifications of the device are not violated.

### 10.5.3 Application Curves

See the oscilloscope captures below for an example of how the CT capacitor can be used to reduce inrush current for  $V_{IN} = 12\text{ V}$ . See the [Adjustable Rise Time \(CT\)](#) section for rise times for corresponding CT values.

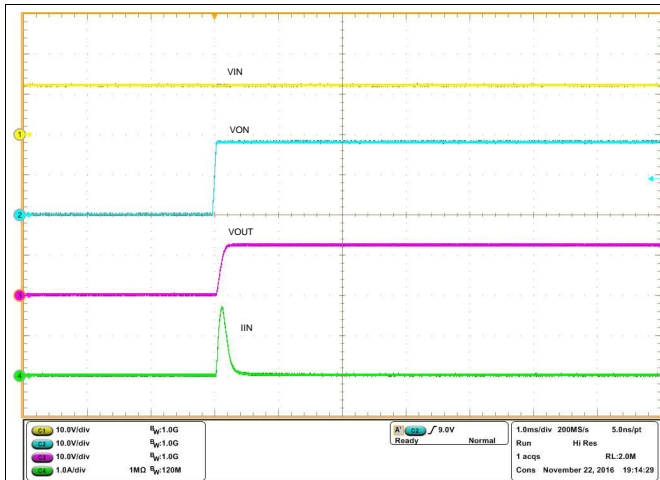

Figure 28. TPS22810 Inrush Current With  $C_L = 22\ \mu\text{F}$ ,  $CT = 0\ \text{pF}$

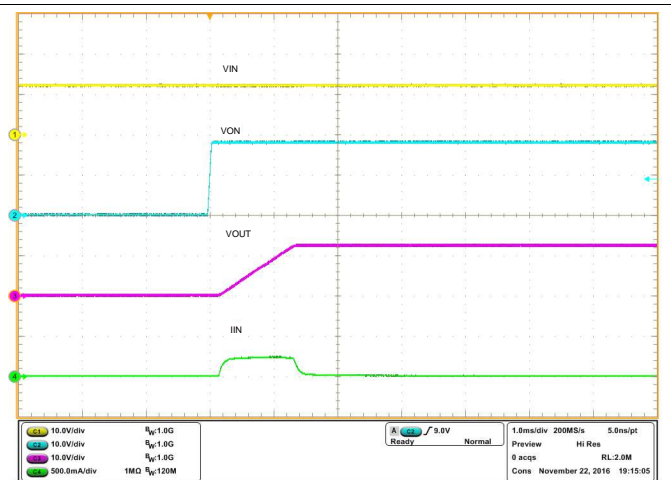

Figure 29. TPS22810 Inrush Current with  $C_L = 22\ \mu\text{F}$ ,  $CT = 4700\ \text{pF}$

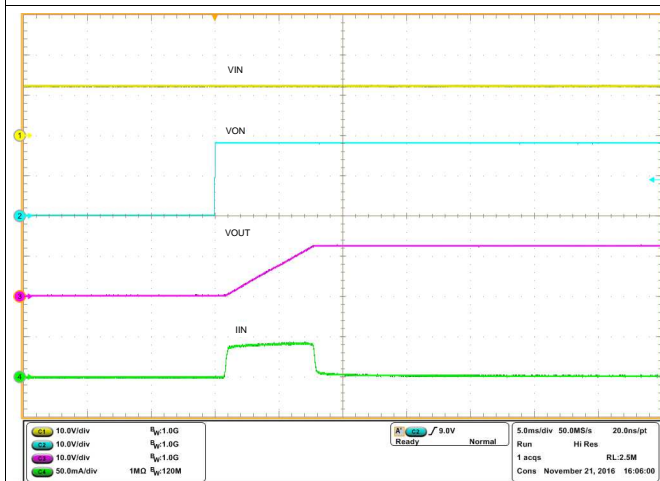

Figure 30. TPS22810 Inrush Current With  $C_L = 22\ \mu\text{F}$ ,  $CT = 27000\ \text{pF}$

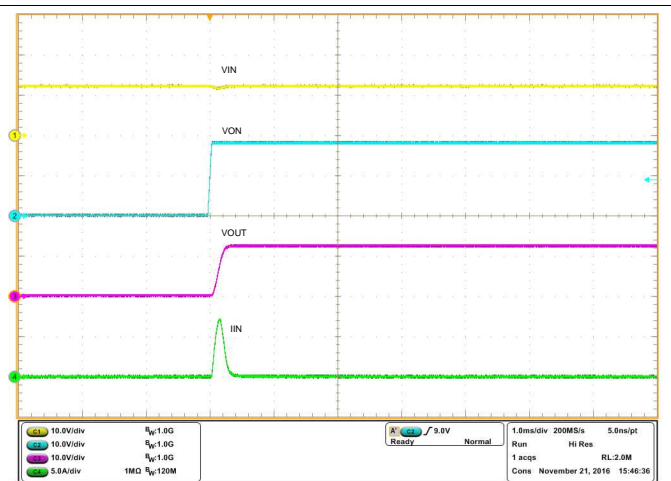

Figure 31. TPS22810 Inrush Current With  $C_L = 100\ \mu\text{F}$ ,  $CT = 0\ \text{pF}$

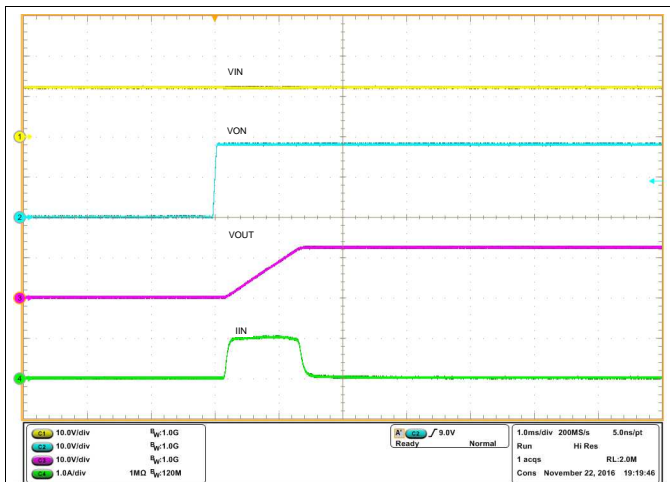

Figure 32. TPS22810 Inrush Current  
With  $C_L = 100 \mu F$ ,  $C_T = 4700 pF$

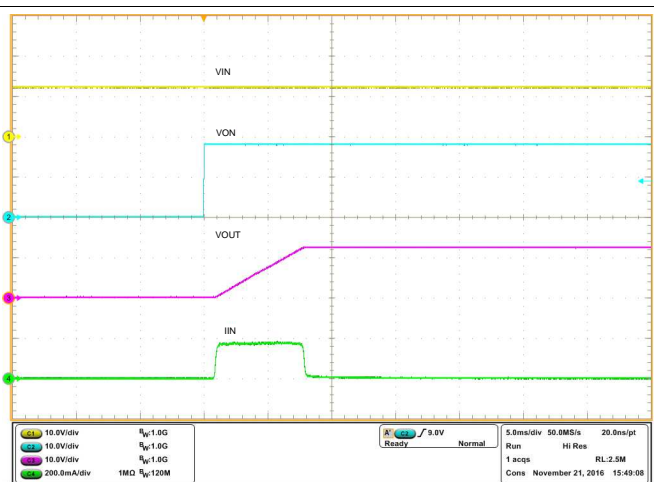

Figure 33. TPS22810 Inrush Current  
With  $C_L = 100 \mu F$ ,  $C_T = 27000 pF$

## 11 Power Supply Recommendations

The device is designed to operate from a  $V_{IN}$  range of 2.7 V to 18 V. This supply must be well regulated and placed as close to the device terminal as possible with the recommended 1- $\mu F$  bypass capacitor. If the supply is located more than a few inches from the device terminals, additional bulk capacitance may be required in addition to the ceramic bypass capacitors. If additional bulk capacitance is required, an electrolytic, tantalum, or ceramic capacitor of 1  $\mu F$  may be sufficient.

The TPS22810 operates regardless of power sequencing order. The order in which voltages are applied to  $V_{IN}$  and ON does not damage the device as long as the voltages do not exceed the absolute maximum operating conditions.

## 12 Layout

### 12.1 Layout Guidelines

- VIN and VOUT traces must be as short and wide as possible to accommodate for high current.
- The VIN pin must be bypassed to ground with low ESR ceramic bypass capacitors. The typical recommended bypass capacitance is 1- $\mu$ F ceramic with X5R or X7R dielectric. This capacitor must be placed as close to the device pins as possible.

### 12.2 Layout Example

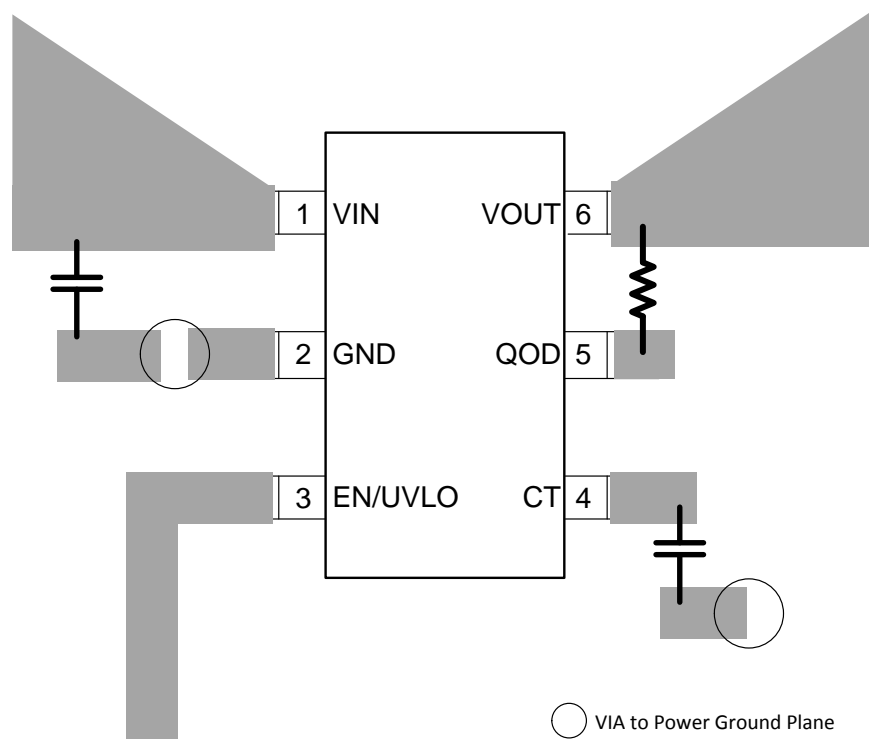

**Figure 34. Recommended Board Layout**

### 12.3 Thermal Considerations

For best performance, all traces must be as short as possible. To be most effective, the input and output capacitors must be placed close to the device to minimize the effects that parasitic trace inductances may have on normal and short-circuit operation. Using wide traces for VIN, VOUT, and GND helps minimize the parasitic electrical effects along with minimizing the case to ambient thermal impedance.

The maximum IC junction temperature must be restricted to 150°C under normal operating conditions. To calculate the maximum allowable dissipation,  $P_{D(max)}$  for a given output current and ambient temperature, use [Equation 14](#).

$$P_{D(MAX)} = \frac{T_{J(MAX)} - T_A}{\theta_{JA}}$$

where

- $P_{D(MAX)}$  is the maximum allowable power dissipation
- $T_{J(MAX)}$  is the maximum allowable junction temperature (150°C for the TPS22810)
- $T_A$  is the ambient temperature of the device
- $\theta_{JA}$  is the junction to air thermal impedance. Refer to the [Thermal Information](#) table. This parameter is highly dependent upon board layout. (14)



## 13 器件和文档支持

### 13.1 器件支持

#### 13.1.1 开发支持

关于 TPS22810 PSpice 瞬态模型，请参见 [《TPS22810 PSpice 瞬态模型》](#)

### 13.2 Documentation Support

#### 13.2.1 Related Documentation

For related documentation see the following:

- [TPS22810 负载开关评估模块](#)
- [选择一个负载开关以代替分立式解决方案](#)
- [负载开关的计时](#)

### 13.3 接收文档更新通知

要接收文档更新通知（包括芯片勘误表），请转至 [ti.com.cn](http://ti.com.cn) 上您的器件对应的产品文件夹。单击右上角的“提醒我” (Alert me) 按钮。点击后，您将每周定期收到已更改的产品信息（如果有的话）。有关更改的详细信息，请查看任意已修订文档的修订历史记录。

### 13.4 Community Resources

下列链接提供到 TI 社区资源的连接。链接的内容由各个分销商“按照原样”提供。这些内容并不构成 TI 技术规范，并且不一定反映 TI 的观点；请参阅 TI 的 [《使用条款》](#)。

**TI E2E™ 在线社区** *TI 的工程师对工程师 (E2E) 社区*。此社区的创建目的在于促进工程师之间的协作。在 [e2e.ti.com](http://e2e.ti.com) 中，您可以咨询问题、分享知识、拓展思路并与同行工程师一道帮助解决问题。

**设计支持** *TI 参考设计支持* 可帮助您快速查找有帮助的 E2E 论坛、设计支持工具以及技术支持的联系信息。

### 13.5 商标

E2E is a trademark of Texas Instruments.  
All other trademarks are the property of their respective owners.

### 13.6 静电放电警告



ESD 可能会损坏该集成电路。德州仪器 (TI) 建议通过适当的预防措施处理所有集成电路。如果不遵守正确的处理措施和安装程序，可能会损坏集成电路。

ESD 的损坏小至导致微小的性能降级，大至整个器件故障。精密的集成电路可能更容易受到损坏，这是因为非常细微的参数更改都可能会导致器件与其发布的规格不相符。

### 13.7 Glossary

[SLYZ022](#) — *TI Glossary*.

This glossary lists and explains terms, acronyms, and definitions.

## 14 机械、封装和可订购信息

以下页面包含机械、封装和可订购信息。这些信息是指定器件的最新可用数据。数据如有变更，恕不另行通知和修订此文档。如欲获取此数据表的浏览器版本，请参阅左侧的导航。

**PACKAGING INFORMATION**

Orderable part number	Status (1)	Material type (2)	Package   Pins	Package qty   Carrier	RoHS (3)	Lead finish/ Ball material (4)	MSL rating/ Peak reflow (5)	Op temp (°C)	Part marking (6)
<a href="#">TPS22810DBVR</a>	Active	Production	SOT-23 (DBV)   6	3000   LARGE T&R	Yes	NIPDAU   SN	Level-1-260C-UNLIM	-40 to 105	19HF
TPS22810DBVR.A	Active	Production	SOT-23 (DBV)   6	3000   LARGE T&R	Yes	NIPDAU	Level-1-260C-UNLIM	-40 to 105	19HF
TPS22810DBVRG4.A	Active	Production	SOT-23 (DBV)   6	3000   LARGE T&R	Yes	NIPDAU	Level-1-260C-UNLIM	-40 to 105	19HF
<a href="#">TPS22810DBVT</a>	Active	Production	SOT-23 (DBV)   6	250   SMALL T&R	Yes	NIPDAU   SN	Level-1-260C-UNLIM	-40 to 105	19HF
TPS22810DBVT.A	Active	Production	SOT-23 (DBV)   6	250   SMALL T&R	Yes	NIPDAU	Level-1-260C-UNLIM	-40 to 105	19HF
<a href="#">TPS22810DRVR</a>	Active	Production	WSON (DRV)   6	3000   LARGE T&R	Yes	NIPDAU	Level-1-260C-UNLIM	-40 to 105	1CRH
TPS22810DRVR.A	Active	Production	WSON (DRV)   6	3000   LARGE T&R	Yes	NIPDAU	Level-1-260C-UNLIM	-40 to 105	1CRH
TPS22810DRVRG4.A	Active	Production	WSON (DRV)   6	3000   LARGE T&R	Yes	NIPDAU	Level-1-260C-UNLIM	-40 to 105	1CRH
<a href="#">TPS22810DRV</a>	Active	Production	WSON (DRV)   6	250   SMALL T&R	Yes	NIPDAU	Level-1-260C-UNLIM	-40 to 105	1CRH
TPS22810DRV.A	Active	Production	WSON (DRV)   6	250   SMALL T&R	Yes	NIPDAU	Level-1-260C-UNLIM	-40 to 105	1CRH

(1) **Status:** For more details on status, see our [product life cycle](#).

(2) **Material type:** When designated, preproduction parts are prototypes/experimental devices, and are not yet approved or released for full production. Testing and final process, including without limitation quality assurance, reliability performance testing, and/or process qualification, may not yet be complete, and this item is subject to further changes or possible discontinuation. If available for ordering, purchases will be subject to an additional waiver at checkout, and are intended for early internal evaluation purposes only. These items are sold without warranties of any kind.

(3) **RoHS values:** Yes, No, RoHS Exempt. See the [TI RoHS Statement](#) for additional information and value definition.

(4) **Lead finish/Ball material:** Parts may have multiple material finish options. Finish options are separated by a vertical ruled line. Lead finish/Ball material values may wrap to two lines if the finish value exceeds the maximum column width.

(5) **MSL rating/Peak reflow:** The moisture sensitivity level ratings and peak solder (reflow) temperatures. In the event that a part has multiple moisture sensitivity ratings, only the lowest level per JEDEC standards is shown. Refer to the shipping label for the actual reflow temperature that will be used to mount the part to the printed circuit board.

(6) **Part marking:** There may be an additional marking, which relates to the logo, the lot trace code information, or the environmental category of the part.

Multiple part markings will be inside parentheses. Only one part marking contained in parentheses and separated by a "~" will appear on a part. If a line is indented then it is a continuation of the previous line and the two combined represent the entire part marking for that device.

**Important Information and Disclaimer:**The information provided on this page represents TI's knowledge and belief as of the date that it is provided. TI bases its knowledge and belief on information provided by third parties, and makes no representation or warranty as to the accuracy of such information. Efforts are underway to better integrate information from third parties. TI has taken and continues to take reasonable steps to provide representative

and accurate information but may not have conducted destructive testing or chemical analysis on incoming materials and chemicals. TI and TI suppliers consider certain information to be proprietary, and thus CAS numbers and other limited information may not be available for release.

In no event shall TI's liability arising out of such information exceed the total purchase price of the TI part(s) at issue in this document sold by TI to Customer on an annual basis.

**OTHER QUALIFIED VERSIONS OF TPS22810 :**

- Automotive : [TPS22810-Q1](#)

NOTE: Qualified Version Definitions:

- Automotive - Q100 devices qualified for high-reliability automotive applications targeting zero defects

**TAPE AND REEL INFORMATION**

**QUADRANT ASSIGNMENTS FOR PIN 1 ORIENTATION IN TAPE**

\*All dimensions are nominal

Device	Package Type	Package Drawing	Pins	SPQ	Reel Diameter (mm)	Reel Width W1 (mm)	A0 (mm)	B0 (mm)	K0 (mm)	P1 (mm)	W (mm)	Pin1 Quadrant
TPS22810DBVR	SOT-23	DBV	6	3000	180.0	8.4	3.2	3.2	1.4	4.0	8.0	Q3
TPS22810DBVT	SOT-23	DBV	6	250	180.0	8.4	3.2	3.2	1.4	4.0	8.0	Q3
TPS22810DRVR	WSO	DRV	6	3000	180.0	8.4	2.3	2.3	1.15	4.0	8.0	Q2
TPS22810DRVT	WSO	DRV	6	250	180.0	8.4	2.3	2.3	1.15	4.0	8.0	Q2

## TAPE AND REEL BOX DIMENSIONS



\*All dimensions are nominal

Device	Package Type	Package Drawing	Pins	SPQ	Length (mm)	Width (mm)	Height (mm)
TPS22810DBVR	SOT-23	DBV	6	3000	210.0	185.0	35.0
TPS22810DBVT	SOT-23	DBV	6	250	210.0	185.0	35.0
TPS22810DRVR	WSON	DRV	6	3000	210.0	185.0	35.0
TPS22810DRVT	WSON	DRV	6	250	210.0	185.0	35.0

# DBV0006A



# PACKAGE OUTLINE

SOT-23 - 1.45 mm max height

SMALL OUTLINE TRANSISTOR



4214840/G 08/2024

## NOTES:

1. All linear dimensions are in millimeters. Any dimensions in parenthesis are for reference only. Dimensioning and tolerancing per ASME Y14.5M.
2. This drawing is subject to change without notice.
3. Body dimensions do not include mold flash or protrusion. Mold flash and protrusion shall not exceed 0.25 per side.
4. Leads 1,2,3 may be wider than leads 4,5,6 for package orientation.
5. Reference JEDEC MO-178.

# EXAMPLE BOARD LAYOUT

DBV0006A

SOT-23 - 1.45 mm max height

SMALL OUTLINE TRANSISTOR



LAND PATTERN EXAMPLE  
EXPOSED METAL SHOWN  
SCALE:15X



SOLDER MASK DETAILS

4214840/G 08/2024

NOTES: (continued)

6. Publication IPC-7351 may have alternate designs.

7. Solder mask tolerances between and around signal pads can vary based on board fabrication site.

# EXAMPLE STENCIL DESIGN

DBV0006A

SOT-23 - 1.45 mm max height

SMALL OUTLINE TRANSISTOR



SOLDER PASTE EXAMPLE  
BASED ON 0.125 mm THICK STENCIL  
SCALE:15X

4214840/G 08/2024

NOTES: (continued)

8. Laser cutting apertures with trapezoidal walls and rounded corners may offer better paste release. IPC-7525 may have alternate design recommendations.
9. Board assembly site may have different recommendations for stencil design.



## GENERIC PACKAGE VIEW

DRV 6

WSON - 0.8 mm max height

PLASTIC SMALL OUTLINE - NO LEAD



Images above are just a representation of the package family, actual package may vary.  
Refer to the product data sheet for package details.

4206925/F



4222173/B 04/2018

NOTES:

1. All linear dimensions are in millimeters. Any dimensions in parenthesis are for reference only. Dimensioning and tolerancing per ASME Y14.5M.
2. This drawing is subject to change without notice.
3. The package thermal pad must be soldered to the printed circuit board for thermal and mechanical performance.

# EXAMPLE BOARD LAYOUT

DRV0006A

WSON - 0.8 mm max height

PLASTIC SMALL OUTLINE - NO LEAD



LAND PATTERN EXAMPLE  
SCALE:25X

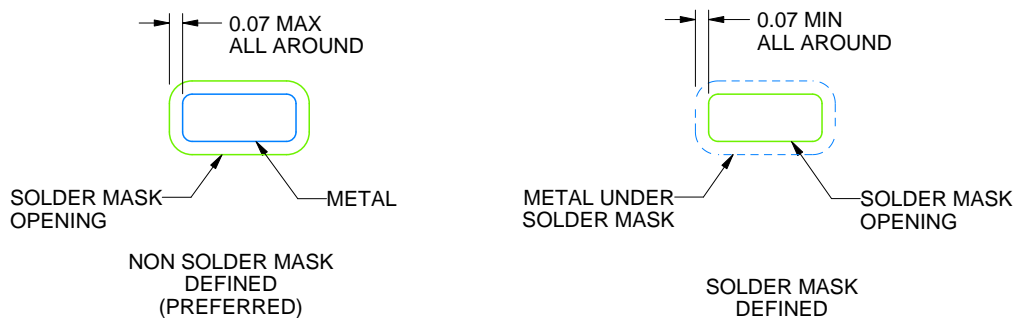

SOLDER MASK DETAILS

4222173/B 04/2018

NOTES: (continued)

4. This package is designed to be soldered to a thermal pad on the board. For more information, see Texas Instruments literature number SLUA271 ([www.ti.com/lit/sluea271](http://www.ti.com/lit/sluea271)).
5. Vias are optional depending on application, refer to device data sheet. If some or all are implemented, recommended via locations are shown.

# EXAMPLE STENCIL DESIGN

DRV0006A

WSON - 0.8 mm max height

PLASTIC SMALL OUTLINE - NO LEAD



SOLDER PASTE EXAMPLE  
BASED ON 0.125 mm THICK STENCIL

EXPOSED PAD #7  
88% PRINTED SOLDER COVERAGE BY AREA UNDER PACKAGE  
SCALE:30X

4222173/B 04/2018

NOTES: (continued)

6. Laser cutting apertures with trapezoidal walls and rounded corners may offer better paste release. IPC-7525 may have alternate design recommendations.

## 重要通知和免责声明

TI“按原样”提供技术和可靠性数据（包括数据表）、设计资源（包括参考设计）、应用或其他设计建议、网络工具、安全信息和其他资源，不保证没有瑕疵且不做任何明示或暗示的担保，包括但不限于对适销性、某特定用途方面的适用性或不侵犯任何第三方知识产权的暗示担保。

这些资源可供使用 TI 产品进行设计的熟练开发人员使用。您将自行承担以下全部责任：(1) 针对您的应用选择合适的 TI 产品，(2) 设计、验证并测试您的应用，(3) 确保您的应用满足相应标准以及任何其他功能安全、信息安全、监管或其他要求。

这些资源如有变更，恕不另行通知。TI 授权您仅可将这些资源用于研发本资源所述的 TI 产品的相关应用。严禁以其他方式对这些资源进行复制或展示。您无权使用任何其他 TI 知识产权或任何第三方知识产权。您应全额赔偿因在这些资源的使用中对 TI 及其代表造成的任何索赔、损害、成本、损失和债务，TI 对此概不负责。

TI 提供的产品受 [TI 的销售条款](#) 或 [ti.com](#) 上其他适用条款/TI 产品随附的其他适用条款的约束。TI 提供这些资源并不会扩展或以其他方式更改 TI 针对 TI 产品发布的适用的担保或担保免责声明。

TI 反对并拒绝您可能提出的任何其他或不同的条款。

邮寄地址：Texas Instruments, Post Office Box 655303, Dallas, Texas 75265  
版权所有 © 2025，德州仪器 (TI) 公司