

LM2585 4V 至 40V、3A 升压、宽 V_{IN} 反激式转换器

1 特性

- 无需外部组件
- 标准电感器和变压器系列
- NPN 输出开关电流为 3A，可切断 65V 电压
- 宽输入电压范围：4V 至 40V
- 可改进瞬态响应、线路稳压和电流限制的电流模式操作
- 100kHz 开关频率
- 内部软启动功能可降低启动过程中的浪涌电流
- 通过电流限制、欠压锁定和热关断为输出晶体管提供保护
- 不同线路和负载条件下的最高系统输出电压容差为 $\pm 4\%$
- 使用 LM2585 并借助 **WEBENCH® 电源设计器** 创建定制设计方案

2 应用

- 反激式稳压器
- 多输出稳压器
- 简单升压稳压器
- 正向转换器

3 说明

LM2585 系列稳压器是专为反激式、升压和正向转换器应用而设计的单片集成电路。该器件提供 4 种不同的输出电压版本：3.3V、5V、12V 和可调节电压。

这些稳压器需要的外部组件很少，因此具有成本效益，并且易于使用。数据表中包含了典型的升压和反激式稳压器电路。另外还列出了二极管和电容器以及标准电感器和反激式变压器系列的选择指南，这些器件专用于与上述开关稳压器协同工作。

该电源开关是一款 3A NPN 器件，可切断 65V 电压。电源开关由电流和热限制电路以及欠压锁定电路进行保护。此 IC 包含 100kHz 固定频率内部振荡器，该振荡器允许使用小型磁体。其他功能包括在启动期间降低浪涌电流的软启动模式、用于改进抑制输入电压和输出负载瞬态的电流模式控制功能，以及逐周期电流限制。在特定输入电压和输出负载条件下，电源系统固定输出电压容差为 $\pm 4\%$ 。

器件信息(1)

器件型号	封装	封装尺寸 (标称值)
LM2585	DDPAK/TO-263 (5)	10.16mm × 8.42mm
	TO-220 (5)	14.986mm × 10.16mm

(1) 如需了解所有可用封装，请参阅数据表末尾的可订购产品附录。

12V 反激式稳压器设计示例

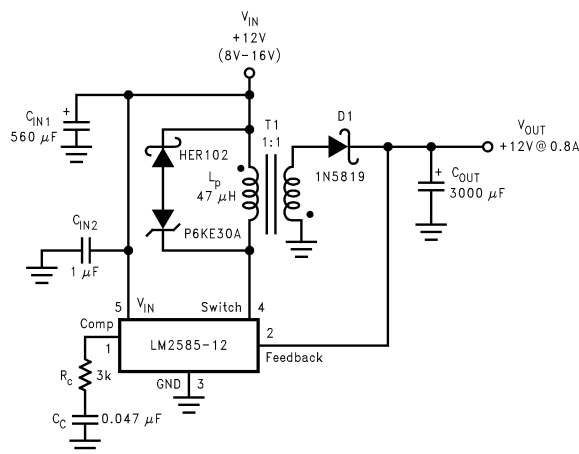

目录

1	特性	1	7.2	Functional Block Diagram	13
2	应用	1	7.3	Feature Description	13
3	说明	1	8	Application and Implementation	15
4	修订历史记录	2	8.1	Application Information	15
5	Pin Configurations	3	8.2	Typical Applications	15
6	Specifications	4	8.3	Additional Application Examples	27
6.1	Absolute Maximum Ratings	4	9	Layout	29
6.2	ESD Ratings	4	9.1	Layout Guidelines	29
6.3	Recommended Operating Ratings	4	9.2	Heat Sink/Thermal Considerations	29
6.4	Thermal Information	5	10	器件和文档支持	31
6.5	Electrical Characteristics: 3.3 V	5	10.1	器件支持	31
6.6	Electrical Characteristics: 5 V	6	10.2	接收文档更新通知	31
6.7	Electrical Characteristics: 12-V	6	10.3	社区资源	31
6.8	Electrical Characteristics: Adjustable	7	10.4	商标	31
6.9	Electrical Characteristics: All Versions	8	10.5	静电放电警告	31
6.10	Typical Characteristics	9	10.6	Glossary	31
7	Detailed Description	11	11	机械、封装和可订购信息	32
7.1	Overview	11			

4 修订历史记录

注：之前版本的页码可能与当前版本有所不同。

Changes from Revision F (April 2013) to Revision G	Page
• 仅有编辑更改，无技术性修订；添加了 WEBENCH 链接	1

Changes from Revision E (April 2013) to Revision F	Page
• Changed layout of National Semiconductor data sheet to TI format.....	30

5 Pin Configurations

**NDH Package
5-Pin TO-220
Top View**

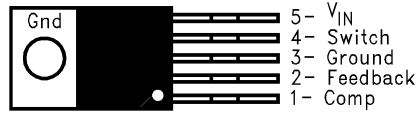

**KTT Package
5-Pin DDPAK/TO-263
Top View**

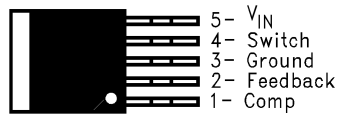

**NDH Package
5-Pin TO-220
Side View**



**KTT Package
5-Pin DDPAK/TO-263
Side View**



6 Specifications

6.1 Absolute Maximum Ratings

over operating free-air temperature range (unless otherwise noted)⁽¹⁾⁽²⁾

Input Voltage		$-0.4\text{ V} \leq V_{IN} \leq 45\text{ V}$
Switch Voltage		$-0.4\text{ V} \leq V_{SW} \leq 65\text{ V}$
Switch Current ⁽³⁾		Internally Limited
Compensation Pin Voltage		$-0.4\text{ V} \leq V_{COMP} \leq 2.4\text{ V}$
Feedback Pin Voltage		$-0.4\text{ V} \leq V_{FB} \leq 2\text{ V}$
Storage Temperature Range		-65°C to $+150^{\circ}\text{C}$
Lead Temperature	(Soldering, 10 sec.)	260°C
Maximum Junction Temperature ⁽⁴⁾		150°C
Power Dissipation ⁽⁴⁾		Internally Limited

- (1) Absolute Maximum Ratings indicate limits beyond which damage to the device may occur. Operating ratings indicate conditions the device is intended to be functional, but device parameter specifications may not be specified under these conditions. For specifications and test conditions see [Electrical Characteristics: All Versions](#).
- (2) If Military/Aerospace specified devices are required, contact the Texas Instruments Sales Office/ Distributors for availability and specifications.
- (3) Note that switch current and output current are not identical in a step-up regulator. Output current cannot be internally limited when the LM2585 is used as a step-up regulator. To prevent damage to the switch, the output current must be externally limited to 3 A. However, output current is internally limited when the LM2585 is used as a flyback regulator (see [Typical Flyback Regulator Applications](#) for more information).
- (4) The junction temperature of the device (T_J) is a function of the ambient temperature (T_A), the junction-to-ambient thermal resistance (θ_{JA}), and the power dissipation of the device (P_D). A thermal shutdown will occur if the temperature exceeds the maximum junction temperature of the device: $P_D \times \theta_{JA} + T_{A(MAX)} \geq T_{J(MAX)}$. For a safe thermal design, check that the maximum power dissipated by the device is less than: $P_D \leq [T_{J(MAX)} - T_{A(MAX)}] / \theta_{JA}$. When calculating the maximum allowable power dissipation, derate the maximum junction temperature—this ensures a margin of safety in the thermal design.

6.2 ESD Ratings

			VALUE	UNIT
$V_{(ESD)}$	Electrostatic discharge (minimum)	Human-body model (HBM), per ANSI/ESDA/JEDEC JS-001 ⁽¹⁾ (C = 100 pF, R = 1.5 kΩ)	2000	V

- (1) JEDEC document JEP155 states that 500-V HBM allows safe manufacturing with a standard ESD control process.

6.3 Recommended Operating Ratings

Supply Voltage		$4\text{ V} \leq V_{IN} \leq 40\text{ V}$
Output Switch Voltage		$0\text{ V} \leq V_{SW} \leq 60\text{ V}$
Output Switch Current		$I_{SW} \leq 3\text{ A}$
Junction Temperature Range		$-40^{\circ}\text{C} \leq T_J \leq +125^{\circ}\text{C}$

6.4 Thermal Information

THERMAL METRIC ⁽¹⁾		LM2585		UNIT
		KTT (DDPAK/TO-263)	NDH (TO-220)	
		5 PINS	5 PINS	
R _{θJA}	Junction-to-ambient thermal resistance	56 ⁽²⁾	65 ⁽³⁾	°C/W
		35 ⁽⁴⁾	45 ⁽⁵⁾	
		26 ⁽⁶⁾	—	
R _{θJC}	Junction-to-case thermal resistance	2	2	°C/W

- (1) For more information about traditional and new thermal metrics, see the [Semiconductor and IC package thermal metrics application report](#).
- (2) Junction-to-ambient thermal resistance for the 5-lead TO-263 mounted horizontally against a PC board area of 0.136 square inches (the same size as the DDPAK/TO-263 package) of 1 oz. (0.0014 in. thick) copper.
- (3) Junction-to-ambient thermal resistance (no external heat sink) for the 5-lead TO-220 package mounted vertically, with ½ inch leads in a socket, or on a PC board with minimum copper area.
- (4) Junction-to-ambient thermal resistance for the 5-lead TO-263 mounted horizontally against a PC board area of 0.4896 square inches (3.6 times the area of the DDPAK/TO-263 package) of 1 oz. (0.0014 in. thick) copper.
- (5) Junction-to-ambient thermal resistance (no external heat sink) for the 5-lead TO-220 package mounted vertically, with ½ inch leads soldered to a PC board containing approximately 4 square inches of (1 oz.) copper area surrounding the leads.
- (6) Junction-to-ambient thermal resistance for the 5-lead TO-263 mounted horizontally against a PC board copper area of 1.0064 square inches (7.4 times the area of the DDPAK/TO-2633 package) of 1 oz. (0.0014 in. thick) copper. Additional copper area reduces thermal resistance further.

6.5 Electrical Characteristics: 3.3 V

Specifications with standard type face are for T_J = 25°C, and those in **bold type face** apply over full **Operating Temperature Range**. Unless otherwise specified, V_{IN} = 5V.

PARAMETER	TEST CONDITIONS	TYP	MIN	MAX	UNIT	
SYSTEM PARAMETERS Test Circuit of Figure 47 ⁽¹⁾						
V _{OUT}	Output Voltage	V _{IN} = 4V to 12V I _{LOAD} = 0.3A to 1.2A	3.3	3.17/ 3.14	3.43/ 3.46	V
ΔV _{OUT} / ΔV _{IN}	Line Regulation	V _{IN} = 4V to 12V I _{LOAD} = 0.3A	20		50/ 100	mV
ΔV _{OUT} / ΔI _{LOAD}	Load Regulation	V _{IN} = 12V I _{LOAD} = 0.3A to 1.2A	20		50/ 100	mV
η	Efficiency	V _{IN} = 5V, I _{LOAD} = 0.3A	76%			
UNIQUE DEVICE PARAMETERS ⁽²⁾						
V _{REF}	Output Reference Voltage	Measured at Feedback Pin V _{COMP} = 1.0V	3.3	3.242/ 3.234	3.358/ 3.366	V
ΔV _{REF}	Reference Voltage Line Regulation	V _{IN} = 4V to 40V	2.0			mV
G _M	Error Amp Transconductance	I _{COMP} = -30 μA to +30 μA V _{COMP} = 1.0V	1.193	0.678	2.259	mmho
A _{VOL}	Error Amp Voltage Gain	V _{COMP} = 0.5V to 1.6V R _{COMP} = 1.0 MΩ ⁽³⁾	260	151/ 75		V/V

- (1) External components such as the diode, inductor, input and output capacitors can affect switching regulator performance. When the LM2585 is used as shown in [Figure 47](#) and [Figure 48](#), system performance will be as specified by the system parameters.
- (2) All room temperature limits are 100% production tested, and all limits at temperature extremes are specified via correlation using standard Statistical Quality Control (SQC) methods.
- (3) A 1-MΩ resistor is connected to the compensation pin (which is the error amplifier output) to ensure accuracy in measuring A_{VOL}.

6.6 Electrical Characteristics: 5 V

PARAMETER	TEST CONDITIONS	TYP	MIN	MAX	UNIT	
SYSTEM PARAMETERS Test Circuit of Figure 47 ⁽¹⁾						
V _{OUT}	Output Voltage	V _{IN} = 4V to 12V I _{LOAD} = 0.3A to 1.1A	5.0	4.80/4.75	5.20/5.25	V
ΔV _{OUT} / ΔV _{IN}	Line Regulation	V _{IN} = 4V to 12V I _{LOAD} = 0.3A	20		50/100	mV
ΔV _{OUT} / ΔI _{LOAD}	Load Regulation	V _{IN} = 12V I _{LOAD} = 0.3A to 1.1A	20		50/100	mV
η	Efficiency	V _{IN} = 12V, I _{LOAD} = 0.6A	80			%
UNIQUE DEVICE PARAMETERS ⁽²⁾						
V _{REF}	Output Reference Voltage	Measured at Feedback Pin V _{COMP} = 1.0V	5.0	4.913/4.900	5.088/5.100	V
ΔV _{REF}	Reference Voltage Line Regulation	V _{IN} = 4V to 40V	3.3			mV
G _M	Error Amp Transconductance	I _{COMP} = -30 μA to +30 μA V _{COMP} = 1.0V	0.750	0.447	1.491	mmho
A _{VOL}	Error Amp Voltage Gain	V _{COMP} = 0.5V to 1.6V R _{COMP} = 1.0 MΩ ⁽³⁾	165	99/49		V/V

- (1) External components such as the diode, inductor, input and output capacitors can affect switching regulator performance. When the LM2585 is used as shown in [Figure 47](#) and [Figure 48](#), system performance will be as specified by the system parameters.
- (2) All room temperature limits are 100% production tested, and all limits at temperature extremes are specified via correlation using standard Statistical Quality Control (SQC) methods.
- (3) A 1-MΩ resistor is connected to the compensation pin (which is the error amplifier output) to ensure accuracy in measuring A_{VOL}.

6.7 Electrical Characteristics: 12-V

PARAMETER	TEST CONDITIONS	TYP	MIN	MAX	UNIT	
SYSTEM PARAMETERS Test Circuit of Figure 48 ⁽¹⁾						
V _{OUT}	Output Voltage	V _{IN} = 4V to 10V I _{LOAD} = 0.2A to 0.8A	12.0	11.52/11.40	12.48/12.60	V
ΔV _{OUT} / ΔV _{IN}	Line Regulation	V _{IN} = 4V to 10V I _{LOAD} = 0.2A	20		100/200	mV
ΔV _{OUT} / ΔI _{LOAD}	Load Regulation	V _{IN} = 10V I _{LOAD} = 0.2A to 0.8A	20		100/200	mV
η	Efficiency	V _{IN} = 10V, I _{LOAD} = 0.6A	93%			
UNIQUE DEVICE PARAMETERS ⁽²⁾						
V _{REF}	Output Reference Voltage	Measured at Feedback Pin V _{COMP} = 1.0V	12.0	11.79/11.76	12.21/12.24	V
ΔV _{REF}	Reference Voltage Line Regulation	V _{IN} = 4V to 40V	7.8			mV
G _M	Error Amp Transconductance	I _{COMP} = -30 μA to +30 μA V _{COMP} = 1.0V	0.328	0.186	0.621	mmho
A _{VOL}	Error Amp Voltage Gain	V _{COMP} = 0.5V to 1.6V R _{COMP} = 1.0 MΩ ⁽³⁾	70	41/21		V/V

- (1) External components such as the diode, inductor, input and output capacitors can affect switching regulator performance. When the LM2585 is used as shown in [Figure 47](#) and [Figure 48](#), system performance will be as specified by the system parameters.
- (2) All room temperature limits are 100% production tested, and all limits at temperature extremes are specified via correlation using standard Statistical Quality Control (SQC) methods.
- (3) A 1-MΩ resistor is connected to the compensation pin (which is the error amplifier output) to ensure accuracy in measuring A_{VOL}.

6.8 Electrical Characteristics: Adjustable

PARAMETER	TEST CONDITIONS	TYP	MIN	MAX	UNIT	
SYSTEM PARAMETERS Test Circuit of Figure 48 ⁽¹⁾						
V _{OUT}	Output Voltage	V _{IN} = 4V to 10V I _{LOAD} = 0.2A to 0.8A	12.0	11.52/11.40	12.48/12.60	V
$\frac{\Delta V_{OUT}}{\Delta V_{IN}}$	Line Regulation	V _{IN} = 4V to 10V I _{LOAD} = 0.2A	20		100/200	mV
$\frac{\Delta V_{OUT}}{\Delta I_{LOAD}}$	Load Regulation	V _{IN} = 10V I _{LOAD} = 0.2A to 0.8A	20		100/200	mV
η	Efficiency	V _{IN} = 10V, I _{LOAD} = 0.6A	93%			
UNIQUE DEVICE PARAMETERS ⁽²⁾						
V _{REF}	Output Reference Voltage	Measured at Feedback Pin V _{COMP} = 1.0V	1.230	1.208/1.205	1.252/1.255	V
ΔV_{REF}	Reference Voltage Line Regulation	V _{IN} = 4V to 40V	1.5			mV
G _M	Error Amp Transconductance	I _{COMP} = -30 μ A to +30 μ A V _{COMP} = 1.0V	3.200	1.800	6.000	mmho
A _{VOL}	Error Amp Voltage Gain	V _{COMP} = 0.5V to 1.6V R _{COMP} = 1.0 M Ω ⁽³⁾	670	400/200		V/V
I _B	Error Amp Input Bias Current	V _{COMP} = 1.0V	125		425/600	nA

- (1) External components such as the diode, inductor, input and output capacitors can affect switching regulator performance. When the LM2585 is used as shown in [Figure 47](#) and [Figure 48](#), system performance will be as specified by the system parameters.
- (2) All room temperature limits are 100% production tested, and all limits at temperature extremes are specified via correlation using standard Statistical Quality Control (SQC) methods.
- (3) A 1-M Ω resistor is connected to the compensation pin (which is the error amplifier output) to ensure accuracy in measuring A_{VOL}.

6.9 Electrical Characteristics: All Versions

PARAMETER		TEST CONDITIONS	TYP	MIN	MAX	UNIT
COMMON DEVICE PARAMETERS for all versions ⁽¹⁾						
I _S	Input Supply Current	(Switch Off) ⁽²⁾	11		15.5/16.5	mA
		I _{SWITCH} = 1.8A	50		100/115	mA
V _{UV}	Input Supply Undervoltage Lockout	R _{LOAD} = 100Ω	3.30	3.05	3.75	V
f _O	Oscillator Frequency	Measured at Switch Pin R _{LOAD} = 100Ω V _{COMP} = 1.0V	100	85/75	115/125	kHz
f _{SC}	Short-Circuit Frequency	Measured at Switch Pin R _{LOAD} = 100Ω V _{FEEDBACK} = 1.15V	25			kHz
V _{EAO}	Error Amplifier Output Swing	Upper Limit ⁽³⁾	2.8	2.6/2.4		V
		Lower Limit ⁽²⁾	0.25		0.40/0.55	V
I _{EAO}	Error Amp Output Current (Source or Sink)	See ⁽⁴⁾	165	110/70	260/320	μA
I _{SS}	Soft Start Current	V _{FEEDBACK} = 0.92V V _{COMP} = 1.0V	11.0	8.0/7.0	17.0/19.0	μA
D	Maximum Duty Cycle	R _{LOAD} = 100Ω ⁽³⁾	98	93/90		%
I _L	Switch Leakage Current	Switch Off V _{SWITCH} = 60V	15		300/600	μA
V _{SUS}	Switch Sustaining Voltage	dV/dT = 1.5V/ns		65		V
V _{SAT}	Switch Saturation Voltage	I _{SWITCH} = 3.0A	0.45		0.65/0.9	V
I _{CL}	NPN Switch Current Limit		4	3	7.0	A

- (1) All room temperature limits are 100% production tested, and all limits at temperature extremes are specified via correlation using standard Statistical Quality Control (SQC) methods.
- (2) To measure this parameter, the feedback voltage is set to a high value, depending on the output version of the device, to force the error amplifier output low. Adj: V_{FB} = 1.41 V; 3.3 V: V_{FB} = 3.8 V; 5 V: V_{FB} = 5.75 V; 12 V: V_{FB} = 13.8 V.
- (3) To measure this parameter, the feedback voltage is set to a low value, depending on the output version of the device, to force the error amplifier output high. Adj: V_{FB} = 1.05 V; 3.3 V: V_{FB} = 2.81 V; 5 V: V_{FB} = 4.25 V; 12 V: V_{FB} = 10.2 V.
- (4) To measure the worst-case error amplifier output current, the LM2585 is tested with the feedback voltage set to its low value (specified in [Tablenote 3](#)) and at its high value (specified in [Tablenote 2](#)).

6.10 Typical Characteristics

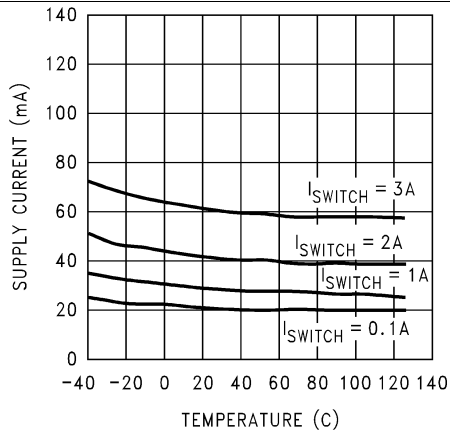

Figure 1. Supply Current vs Temperature

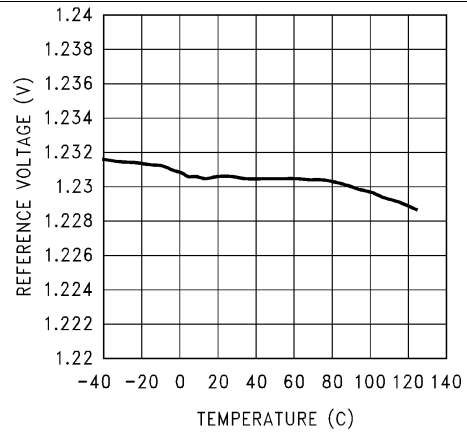

Figure 2. Reference Voltage vs Temperature

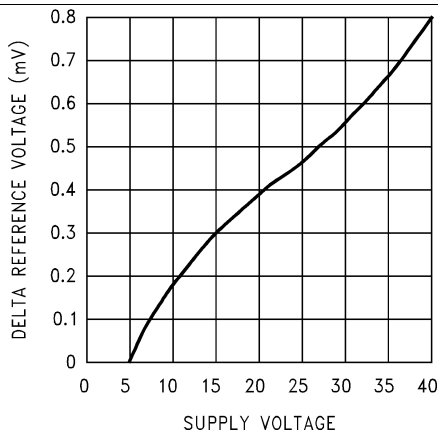

Figure 3. ΔReference Voltage vs Supply Voltage

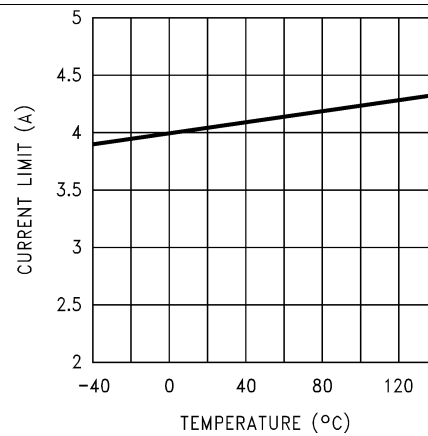

Figure 4. Current Limit vs Temperature

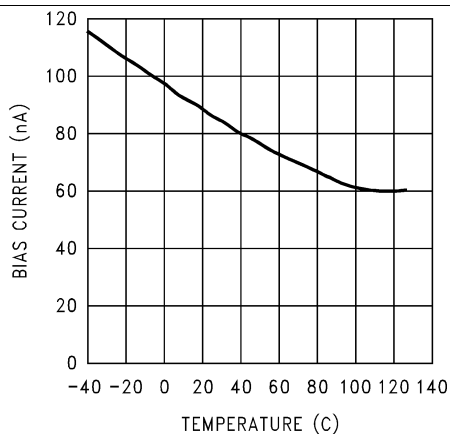

Figure 5. Feedback Pin Bias Current vs Temperature

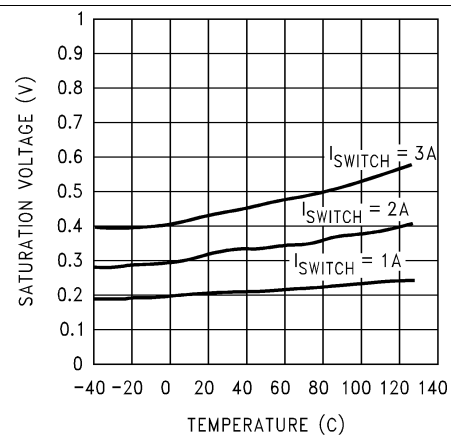

Figure 6. Switch Saturation Voltage vs Temperature

Typical Characteristics (continued)

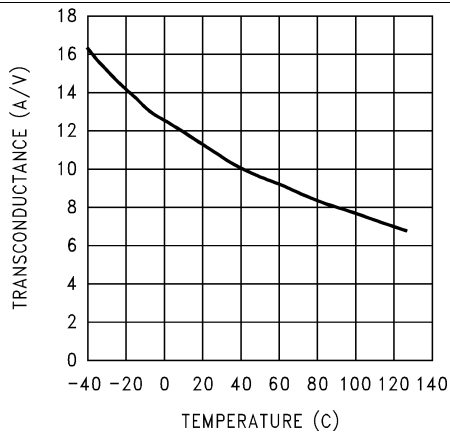

Figure 7. Switch Transconductance vs Temperature

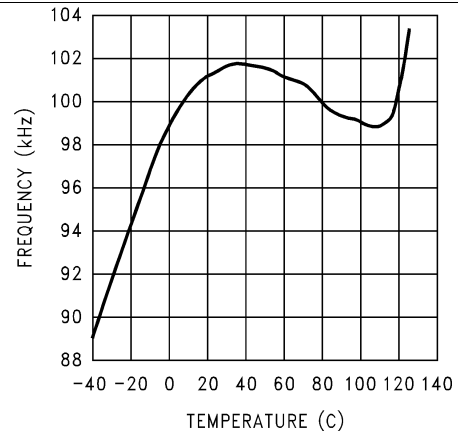

Figure 8. Oscillator Frequency vs Temperature

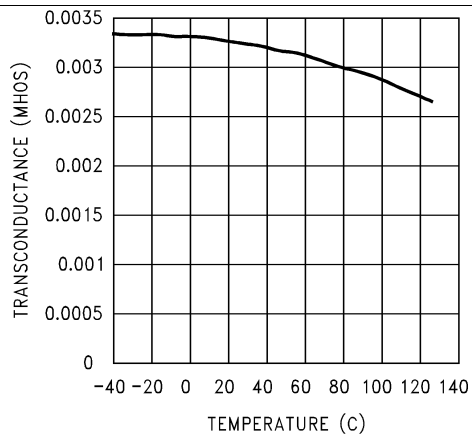

Figure 9. Error Amp Transconductance vs Temperature

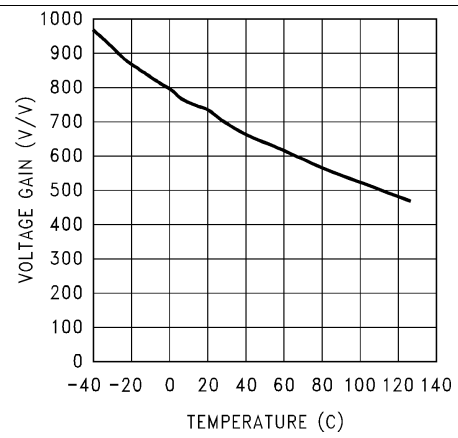

Figure 10. Error Amp Voltage Gain vs Temperature

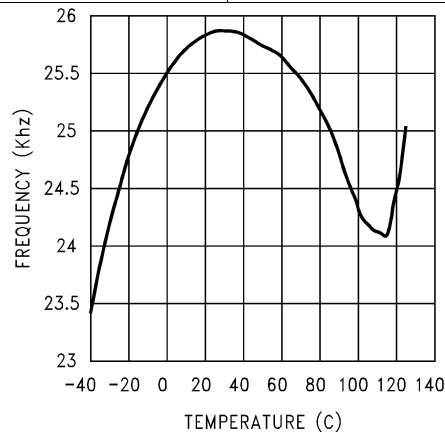

Figure 11. Short Circuit Frequency vs Temperature

7 Detailed Description

7.1 Overview

The LM2585 is ideally suited for use in the flyback regulator topology. The flyback regulator can produce a single output voltage, such as the one shown in Figure 12, or multiple output voltages. In Figure 12, the flyback regulator generates an output voltage that is inside the range of the input voltage. This feature is unique to flyback regulators and cannot be duplicated with buck or boost regulators.

The operation of a flyback regulator is as follows (refer to Figure 12): when the switch is on, current flows through the primary winding of the transformer, T1, storing energy in the magnetic field of the transformer. Note that the primary and secondary windings are out of phase, so no current flows through the secondary when current flows through the primary. When the switch turns off, the magnetic field collapses, reversing the voltage polarity of the primary and secondary windings. Now rectifier D1 is forward biased and current flows through it, releasing the energy stored in the transformer. This produces voltage at the output.

The output voltage is controlled by modulating the peak switch current. This is done by feeding back a portion of the output voltage to the error amp, which amplifies the difference between the feedback voltage and a 1.23-V reference. The error amp output voltage is compared to a ramp voltage proportional to the switch current (in other words, inductor current during the switch on time). The comparator terminates the switch on time when the two voltages are equal, thereby controlling the peak switch current to maintain a constant output voltage.

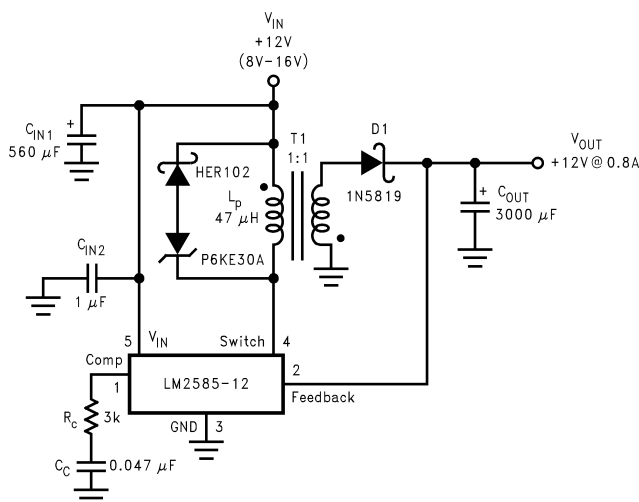
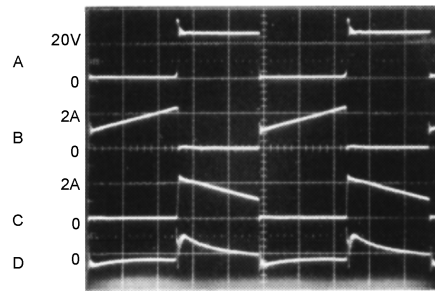

Figure 12. 12-V Flyback Regulator Design Example

As shown in Figure 12, the LM2585 can be used as a flyback regulator by using a minimum number of external components. The switching waveforms of this regulator are shown in Figure 13. Typical characteristics observed during the operation of this circuit are shown in Figure 14.

Overview (continued)



A: Switch Voltage, 20 V/div
 B: Switch Current, 2 A/div
 C: Output Rectifier Current, 2 A/div
 D: Output Ripple Voltage, 50 mV/div
 AC-Coupled
Horizontal: 2 μ s/div

Figure 13. Switching Waveforms

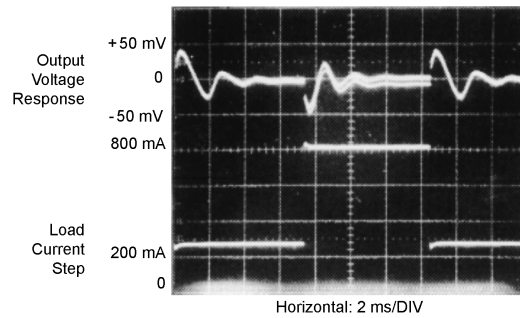
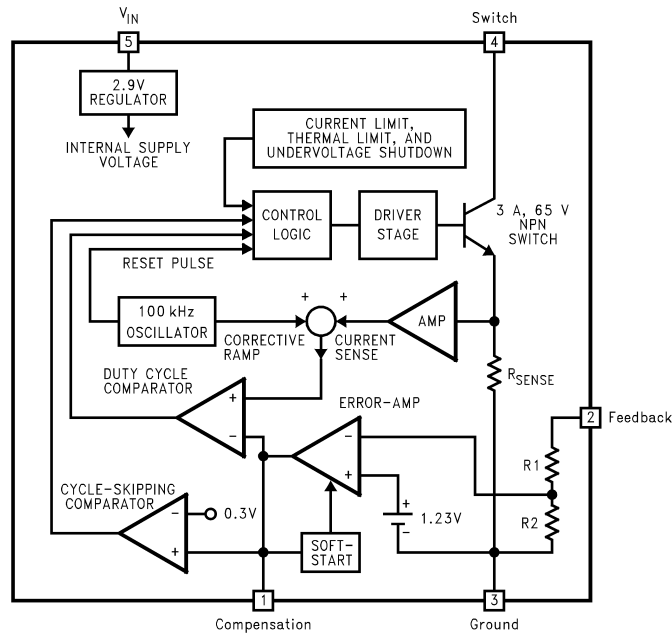

Figure 14. V_{OUT} Load Current Step Response

7.2 Functional Block Diagram



For Fixed Versions

3.3V, R1 = 3.4k, R2 = 2k

5V, R1 = 6.15k, R2 = 2k

12V, R1 = 8.73k, R2 = 1k

For Adj. Version

R1 = Short (0Ω), R2 = Open

7.3 Feature Description

7.3.1 Step-Up (Boost) Regulator Operation

Figure 15 shows the LM2585 used as a step-up (boost) regulator. This is a switching regulator that produces an output voltage greater than the input supply voltage.

A brief explanation of how the LM2585 boost regulator works is as follows (refer to Figure 15). When the NPN switch turns on, the inductor current ramps up at the rate of V_{IN}/L , storing energy in the inductor. When the switch turns off, the lower end of the inductor flies above V_{IN} , discharging its current through diode (D) into the output capacitor (C_{OUT}) at a rate of $(V_{OUT} - V_{IN})/L$. Thus, energy stored in the inductor during the switch on time is transferred to the output during the switch off time. The output voltage is controlled by adjusting the peak switch current, as described in .

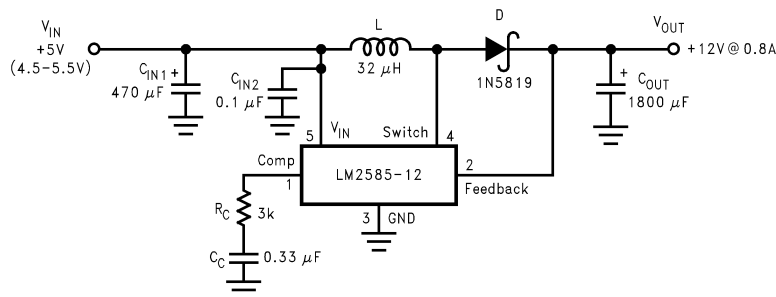
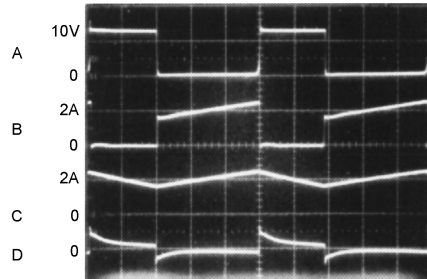

Figure 15. 12-V Boost Regulator

Feature Description (continued)

By adding a small number of external components (as shown in Figure 15), the LM2585 can be used to produce a regulated output voltage that is greater than the applied input voltage. The switching waveforms observed during the operation of this circuit are shown in Figure 16. Typical performance of this regulator is shown in Figure 17.



A: Switch Voltage, 10 V/div
 B: Switch Current, 2 A/div
 C: Inductor Current, 2 A/div
 D: Output Ripple Voltage, 100 mV/div, AC-Coupled
Horizontal: 2 μs/div

Figure 16. Switching Waveforms

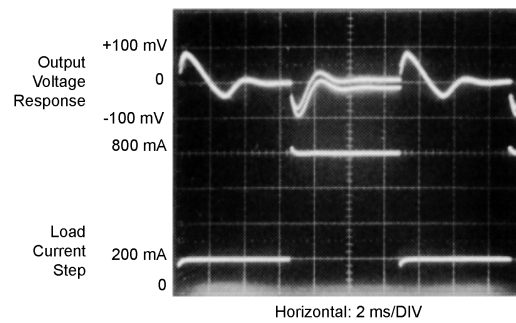

Figure 17. V_{OUT} Response To Load Current Step

8 Application and Implementation

8.1 Application Information

The LM2585 series of regulators are monolithic integrated circuits specifically designed for flyback, step-up (boost), and forward converter applications. Requiring a minimum number of external components, these regulators are cost effective and simple to use.

8.2 Typical Applications

8.2.1 Typical Boost Regulator Applications

Figure 18 through Figure 21 show four typical boost applications—one fixed and three using the adjustable version of the LM2585. Each drawing contains the part number(s) and manufacturer(s) for every component. For the fixed 12-V output application, the part numbers and manufacturers' names for the inductor are listed in Table 3. For applications with different output voltages, refer to the *Switchers Made Simple* software.

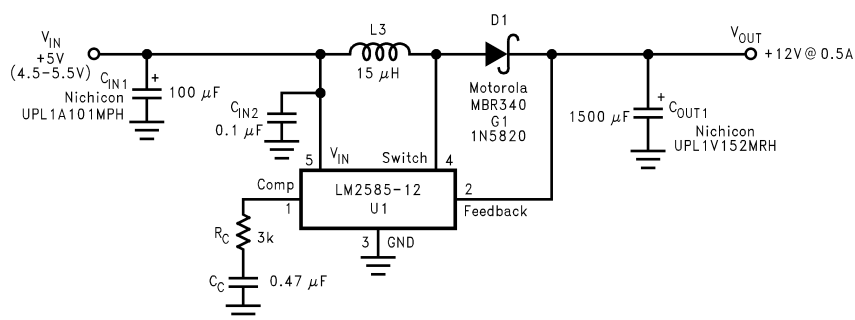

Figure 18. 5-V to 12-V Boost Regulator

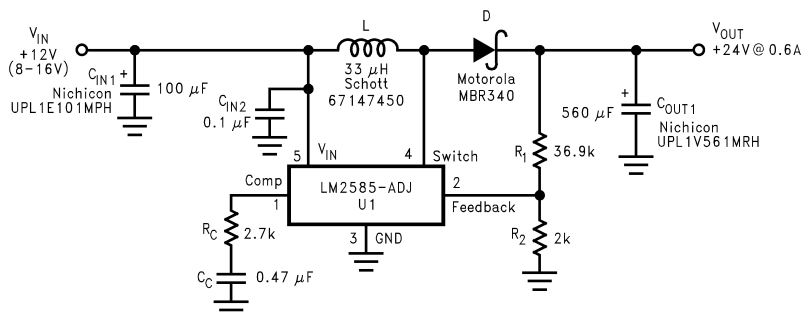

Figure 19. 12-V to 24-V Boost Regulator

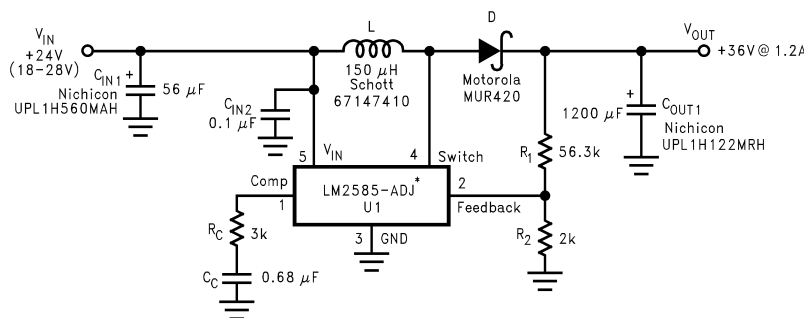
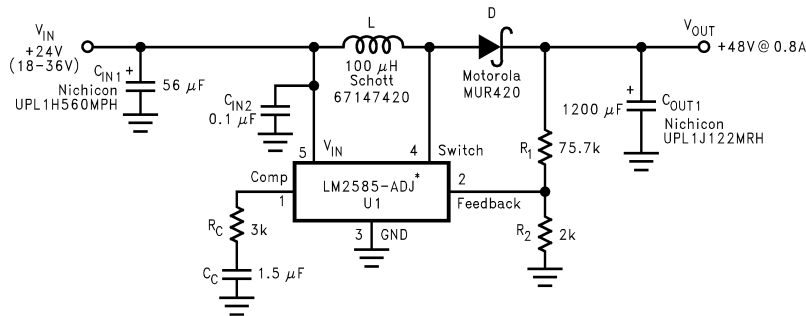

Figure 20. 24-V to 36-V Boost Regulator

Typical Applications (continued)



*The LM2585 will require a heat sink in these applications. The size of the heat sink will depend on the maximum ambient temperature. To calculate the thermal resistance of the IC and the size of the heat sink needed, see [Heat Sink/Thermal Considerations](#)

Figure 21. 24-V to 48-V Boost Regulator

8.2.2 Typical Flyback Regulator Applications

Figure 22 through Figure 27 show six typical flyback applications, varying from single output to triple output. Each drawing contains the part number(s) and manufacturer(s) for every component except the transformer. For the transformer part numbers and manufacturers names, the table in Table 1.

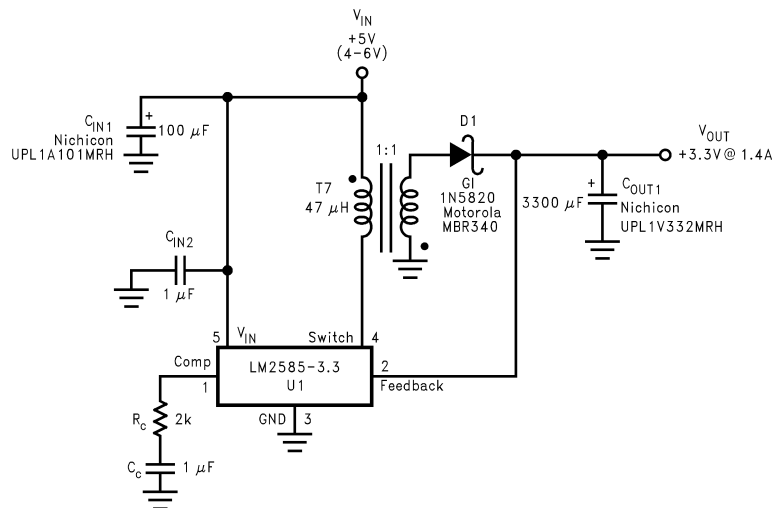

Figure 22. Single-Output Flyback Regulator

Typical Applications (continued)

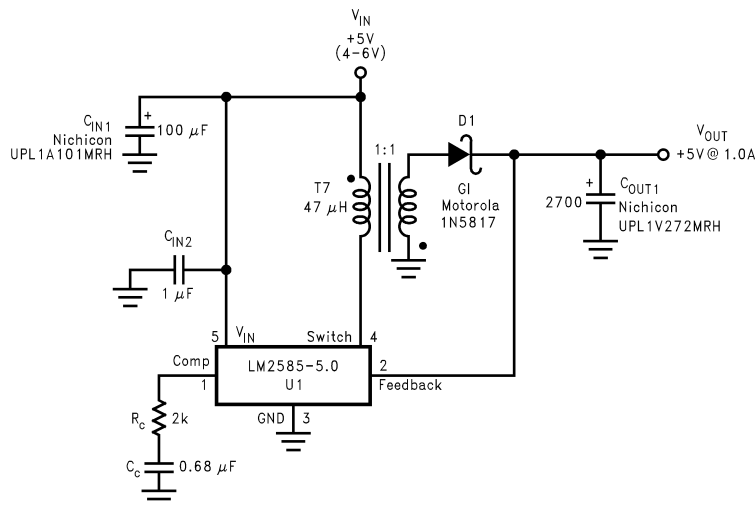

Figure 23. Single-Output Flyback Regulator

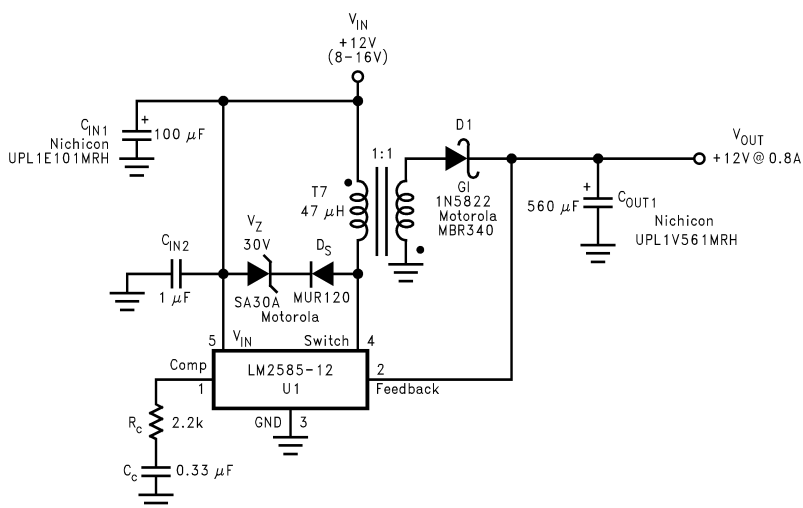

Figure 24. Single-Output Flyback Regulator

Typical Applications (continued)

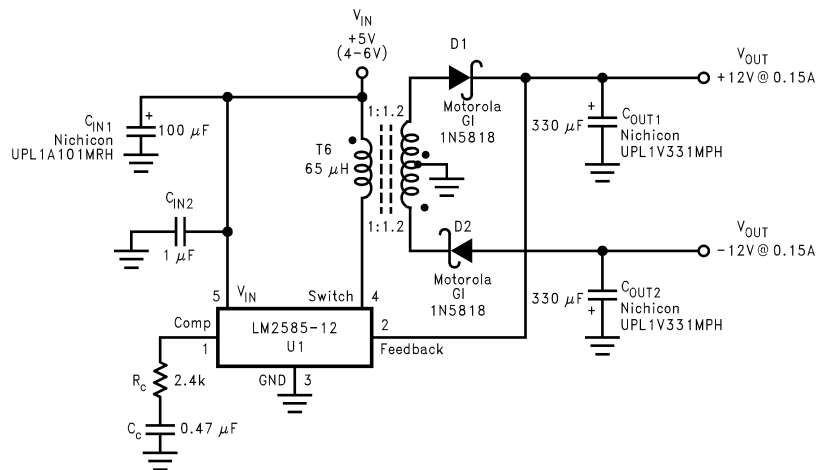

Figure 25. Dual-Output Flyback Regulator

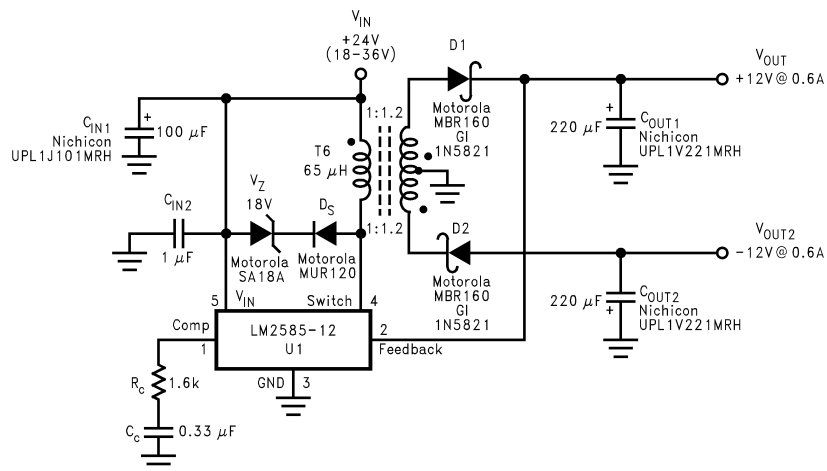

Figure 26. Dual-Output Flyback Regulator

Typical Applications (continued)

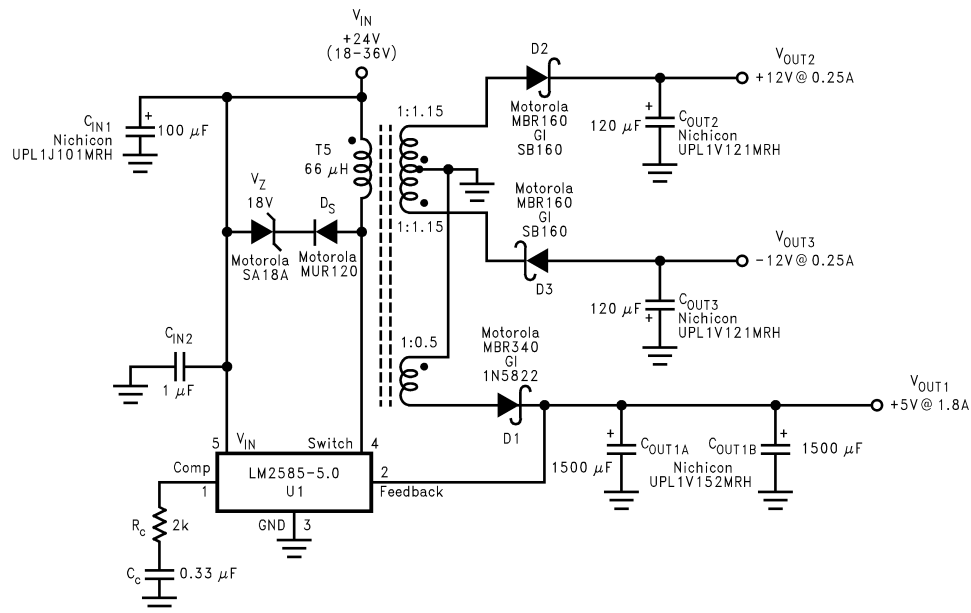

Figure 27. Triple-Output Flyback Regulator

Typical Applications (continued)

8.2.2.1 Transformer Selection (T)

Table 1 lists the standard transformers available for flyback regulator applications. Included in the table are the turns ratio(s) for each transformer, as well as the output voltages, input voltage ranges, and the maximum load currents for each circuit.

Table 1. Transformer Selection Table

Applications	Figure 22	Figure 23	Figure 24	Figure 25	Figure 26	Figure 27
Transformers	T7	T7	T7	T6	T6	T5
V_{IN}	4V–6V	4V–6V	8V–16V	4V–6V	18V–36V	18V–36V
V_{OUT1}	3.3V	5V	12V	12V	12V	5V
I_{OUT1} (Max)	1.4A	1A	0.8A	0.15A	0.6A	1.8A
N_1	1	1	1	1.2	1.2	0.5
V_{OUT2}				–12V	–12V	12V
I_{OUT2} (Max)				0.15A	0.6A	0.25A
N_2				1.2	1.2	1.15
V_{OUT3}						–12V
I_{OUT3} (Max)						0.25A
N_3						1.15

Table 2. Transformer Manufacturer Guide

Transformer Type	Manufacturers' Part Numbers					
	Coilcraft (1)	Coilcraft (1) Surface Mount	Pulse (2) Surface Mount	Pulse (2)	Renco (3)	Schott (4)
T5	Q4338-B	Q4437-B	PE-68413	—	RL-5532	67140890
T6	Q4339-B	Q4438-B	PE-68414	—	RL-5533	67140900
T7	S6000-A	S6057-A	—	PE-68482	RL-5751	26606

- (1) Coilcraft Inc. Phone: (800) 322-2645 www.coilcraft.com
 (2) Pulse Engineering Inc. Phone: (619) 674-8100 www.digikey.com
 (3) Renco Electronics Inc. Phone: (800) 645-5828 www.cdiweb.com/rengo
 (4) Schott Corp. Phone: (612) 475-1173 www.schottcorp.com/

8.2.2.2 Transformer Footprints

Figure 28 through Figure 42 show the footprints of each transformer, listed in Table 1.

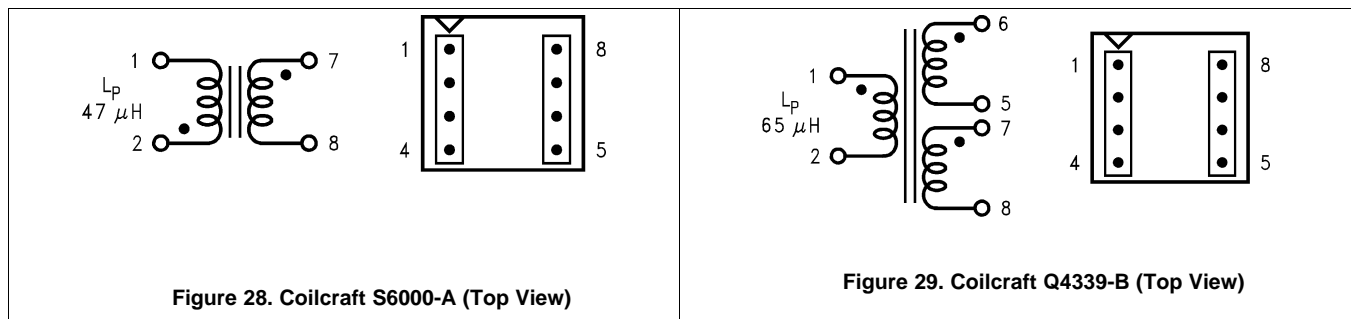

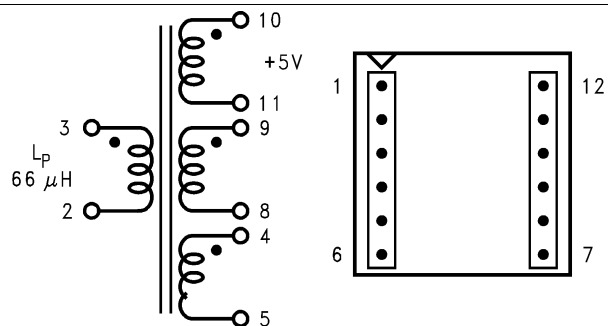

Figure 30. Coilcraft Q4437-B (Top View) (Surface Mount)

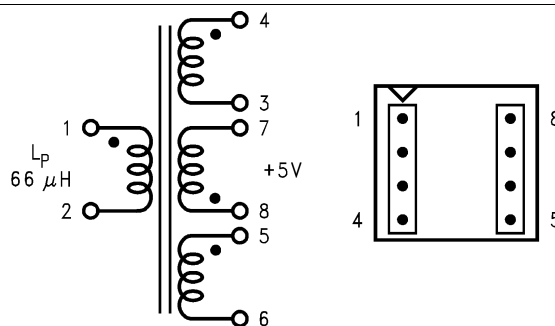

Figure 31. Coilcraft Q4338-B (Top View)

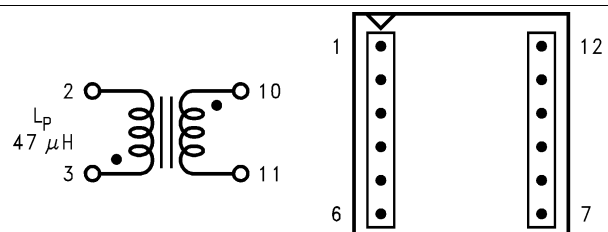

Figure 32. Coilcraft S6057-A (Top View) (Surface Mount)

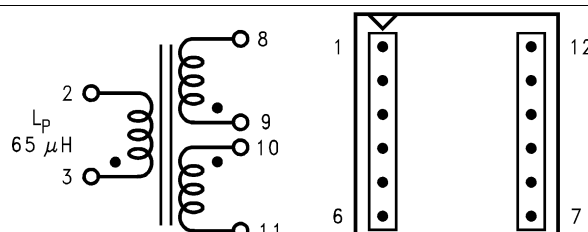

Figure 33. Coilcraft Q4438-B (Top View) (Surface Mount)

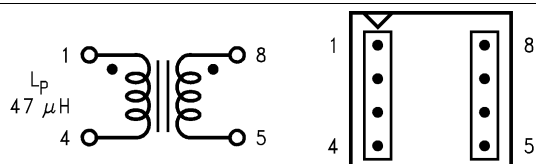

Figure 34. Pulse PE-68482 (Top View)

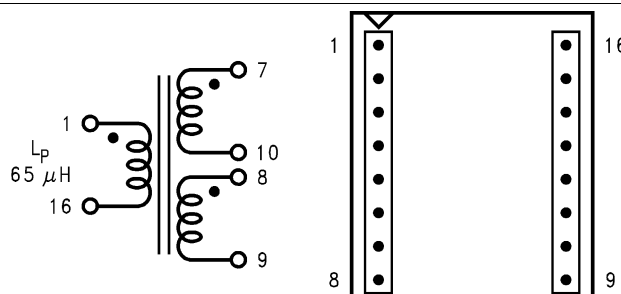

Figure 35. Pulse Pe-68414 (Top View) (Surface Mount)

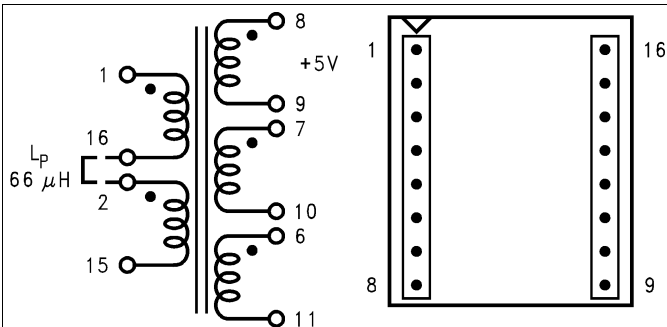

Figure 36. Pulse PE-68413 (Top View) (Surface Mount)

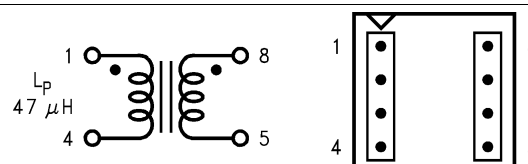

Figure 37. Renco RI-5751 (Top View)

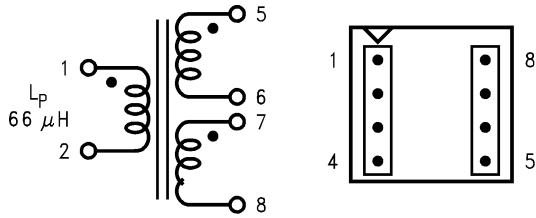

Figure 38. Renco RI-5533 (Top View)

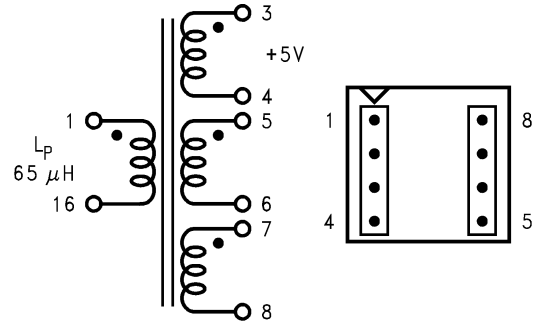

Figure 39. Renco RI-5532 (Top View)

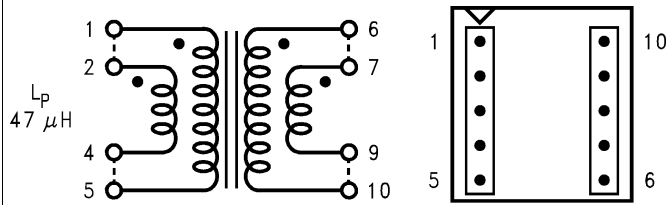

Figure 40. Schott 26606 (Top View)

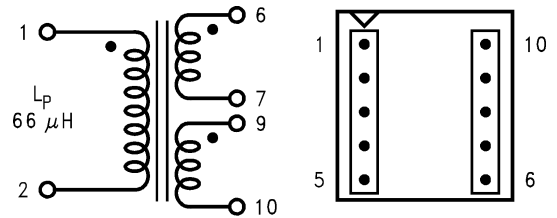

Figure 41. Schott 67140900 (Top View)

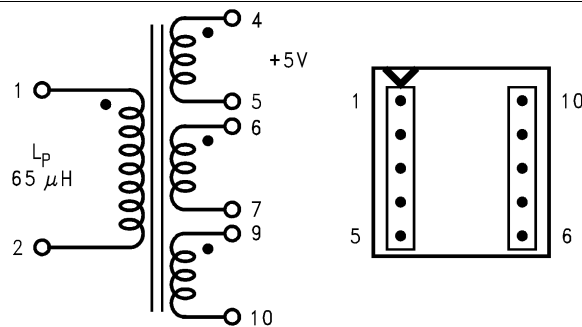

Figure 42. Schott 67140890 (Top View)

8.2.3 Design Requirements

Table 3 contains a table of standard inductors, by part number and corresponding manufacturer, for the fixed output regulator of Figure 18.

Table 3. Inductor Selection Table

Coilcraft ⁽¹⁾	Pulse ⁽²⁾	Renco ⁽³⁾	Schott ⁽⁴⁾	Schott (Surface Mount) ⁽⁴⁾
D03316-153	PE-53898	RL-5471-7	67146510	67146540

(1) Coilcraft Inc. Phone: (800) 322-2645 1102 Silver Lake Road, Cary, IL 60013 Fax: (708) 639-1469

(2) Pulse Engineering Inc. Phone: (619) 674-8100 12220 World Trade Drive, San Diego, CA 92128 Fax: (619) 674-8262

(3) Renco Electronics Inc. Phone (800) 645-5828 60 Jeffryn Blvd. East, Deer Park, NY 11729 Fax: (516) 586-5562

(4) Schott Corp. Phone: (612) 475-1173 1000 Parkers Lane Road, Wayzata, MN 55391 Fax: (612) 475-1786

8.2.4 Detailed Design Procedure

8.2.4.1 Custom Design With WEBENCH® Tools

[Click here](#) to create a custom design using the LM2585 device with the WEBENCH® Power Designer.

1. Start by entering the input voltage (V_{IN}), output voltage (V_{OUT}), and output current (I_{OUT}) requirements.
2. Optimize the design for key parameters such as efficiency, footprint, and cost using the optimizer dial.
3. Compare the generated design with other possible solutions from Texas Instruments.

The WEBENCH Power Designer provides a customized schematic along with a list of materials with real-time pricing and component availability.

In most cases, these actions are available:

- Run electrical simulations to see important waveforms and circuit performance
- Run thermal simulations to understand board thermal performance
- Export customized schematic and layout into popular CAD formats
- Print PDF reports for the design, and share the design with colleagues

Get more information about WEBENCH tools at www.ti.com/WEBENCH.

8.2.4.2 Programming Output Voltage (Selecting R₁ And R₂)

Referring to the adjustable regulator in Figure 50, the output voltage is programmed by the resistors R₁ and R₂ by the following formula:

$$V_{OUT} = V_{REF} (1 + R_1/R_2)$$

where

- V_{REF} = 1.23 V (1)

Resistors R₁ and R₂ divide the output voltage down so that it can be compared with the 1.23-V internal reference. With R₂ between 1k and 5k, R₁ is:

$$R_1 = R_2 (V_{OUT}/V_{REF} - 1)$$

where

- V_{REF} = 1.23V (2)

For best temperature coefficient and stability with time, use 1% metal film resistors.

8.2.4.3 Short Circuit Condition

Due to the inherent nature of boost regulators, when the output is shorted (Figure 50), current flows directly from the input, through the inductor and the diode, to the output, bypassing the switch. The current limit of the switch *does not* limit the output current for the entire circuit. To protect the load and prevent damage to the switch, the current must be externally limited, either by the input supply or at the output with an external current limit circuit. The external limit should be set to the maximum switch current of the device, which is 3A.

In a flyback regulator application (Figure 43), using the standard transformers, the LM2585 will survive a short circuit to the main output. When the output voltage drops to 80% of its nominal value, the frequency drops to 25 kHz. With a lower frequency, off times are larger. With the longer off times, the transformer can release all of its stored energy before the switch turns back on. Hence, the switch turns on initially with zero current at its collector. In this condition, the switch current limit will limit the peak current, saving the device.

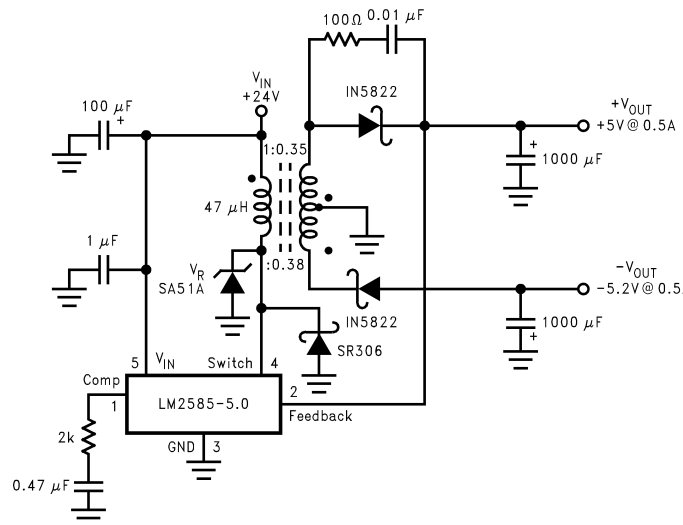

Figure 43. Flyback Regulator

8.2.4.4 Flyback Regulator Input Capacitors

A flyback regulator draws discontinuous pulses of current from the input supply. Therefore, there are two input capacitors needed in a flyback regulator; one for energy storage and one for filtering (Figure 43). Both are required due to the inherent operation of a flyback regulator. To keep a stable or constant voltage supply to the LM2585, a storage capacitor (≥100 µF) is required. If the input source is a rectified DC supply and/or the application has a wide temperature range, the required rms current rating of the capacitor might be very large. This means a larger value of capacitance or a higher voltage rating will be needed of the input capacitor. The storage capacitor will also attenuate noise which may interfere with other circuits connected to the same input supply voltage.

In addition, a small bypass capacitor is required due to the noise generated by the input current pulses. To eliminate the noise, insert a 1.0 μF ceramic capacitor between V_{IN} and ground as close as possible to the device.

8.2.4.5 Switch Voltage Limits

In a flyback regulator, the maximum steady-state voltage appearing at the switch, when it is off, is set by the transformer turns ratio, N , the output voltage, V_{OUT} , and the maximum input voltage, V_{IN} (maximum):

$$V_{\text{SW(OFF)}} = V_{\text{IN}} (\text{Max}) + (V_{\text{OUT}} + V_{\text{F}})/N$$

where

- V_{F} is the forward biased voltage of the output diode and is 0.5 V for Schottky diodes and 0.8 V for ultra-fast recovery diodes (typically). (3)

In certain circuits, there exists a voltage spike, V_{LL} , superimposed on top of the steady-state voltage (Figure 13, waveform A). Usually, this voltage spike is caused by the transformer leakage inductance and/or the output rectifier recovery time. To “clamp” the voltage at the switch from exceeding its maximum value, a transient suppressor in series with a diode is inserted across the transformer primary (as shown in the circuit on the front page and other flyback regulator circuits throughout the datasheet). The schematic in Figure 43 shows another method of clamping the switch voltage. A single voltage transient suppressor (the SA51A) is inserted at the switch pin. This method clamps the total voltage across the switch, not just the voltage across the primary.

If poor circuit layout techniques are used (see [Layout Guidelines](#)), negative voltage transients may appear on the Switch pin (pin 4). Applying a negative voltage (with respect to the IC's ground) to any monolithic IC pin causes erratic and unpredictable operation of that IC. This holds true for the LM2585 IC as well. When used in a flyback regulator, the voltage at the Switch pin (pin 4) can go negative when the switch turns on. The “ringing” voltage at the switch pin is caused by the output diode capacitance and the transformer leakage inductance forming a resonant circuit at the secondary(ies). The resonant circuit generates the “ringing” voltage, which gets reflected back through the transformer to the switch pin. There are two common methods to avoid this problem. One is to add an RC snubber around the output rectifier(s), as in Figure 43. The values of the resistor and the capacitor must be chosen so that the voltage at the Switch pin does not drop below -0.4 V. The resistor may range in value between 10 Ω and 1 k Ω , and the capacitor will vary from 0.001 μF to 0.1 μF . Adding a snubber will (slightly) reduce the efficiency of the overall circuit.

The other method to reduce or eliminate the “ringing” is to insert a Schottky diode clamp between pins 4 and 3 (ground), also shown in Figure 43. This prevents the voltage at pin 4 from dropping below -0.4 V. The reverse voltage rating of the diode must be greater than the switch off voltage.

8.2.4.6 Output Voltage Limitations

The maximum output voltage of a boost regulator is the maximum switch voltage minus a diode drop. In a flyback regulator, the maximum output voltage is determined by the turns ratio, N , and the duty cycle, D , by the equation:

$$V_{\text{OUT}} \approx N \times V_{\text{IN}} \times D / (1 - D)$$
 (4)

The duty cycle of a flyback regulator is determined by the following equation:

$$D = \frac{V_{\text{OUT}} + V_{\text{F}}}{N(V_{\text{IN}} - V_{\text{SAT}}) + V_{\text{OUT}} + V_{\text{F}}} \approx \frac{V_{\text{OUT}}}{N(V_{\text{IN}}) + V_{\text{OUT}}}$$
 (5)

Theoretically, the maximum output voltage can be as large as desired—just keep increasing the turns ratio of the transformer. However, there exists some physical limitations that prevent the turns ratio, and thus the output voltage, from increasing to infinity. The physical limitations are capacitances and inductances in the LM2585 switch, the output diode(s), and the transformer—such as reverse recovery time of the output diode (mentioned above).

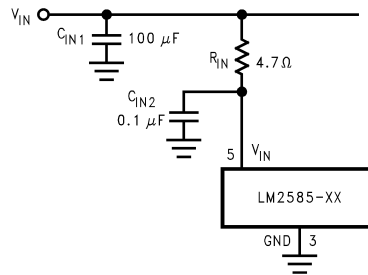
Figure 44. Input Line Filter

8.2.4.7 Noisy Input Line Condition

A small, low-pass RC filter should be used at the input pin of the LM2585 if the input voltage has an unusual large amount of transient noise, such as with an input switch that bounces. The circuit in [Figure 44](#) demonstrates the layout of the filter, with the capacitor placed from the input pin to ground and the resistor placed between the input supply and the input pin. Note that the values of R_{IN} and C_{IN} shown in the schematic are good enough for most applications, but some readjusting might be required for a particular application. If efficiency is a major concern, replace the resistor with a small inductor (say 10 μ H and rated at 100 mA).

8.2.4.8 Stability

All current-mode controlled regulators can suffer from an instability, known as subharmonic oscillation, if they operate with a duty cycle above 50%. To eliminate subharmonic oscillations, a minimum value of inductance is required to ensure stability for all boost and flyback regulators. The minimum inductance is given by:

$$L(\text{Min}) = \frac{2.92 [(V_{IN}(\text{Min}) - V_{SAT}) \times (2D(\text{Max}) - 1)]}{1 - D(\text{Max})} (\mu\text{H})$$

where

- V_{SAT} is the switch saturation voltage and can be found in the Characteristic Curves.

(6)

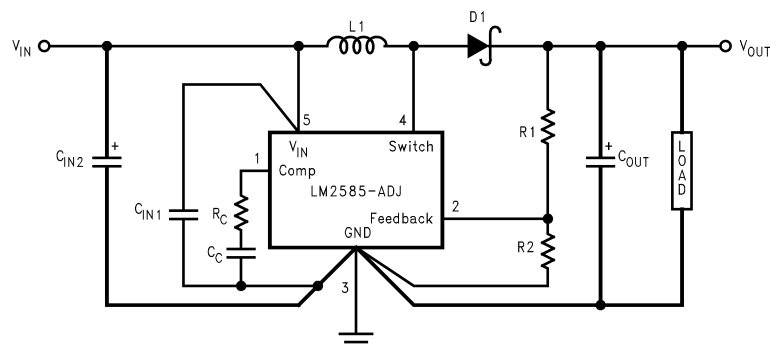
Figure 45. Circuit Board Layout

8.2.5 Application Curve

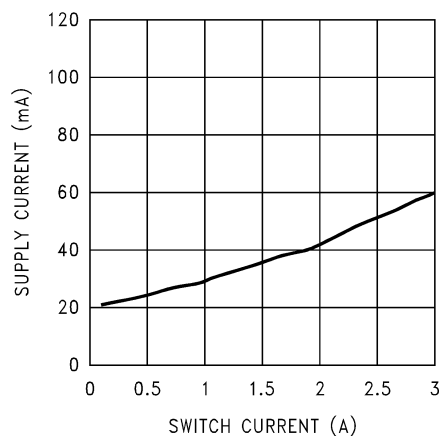
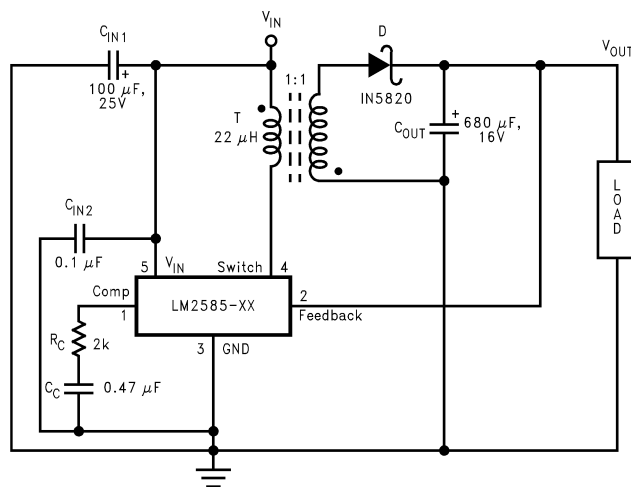

Figure 46. Supply Current vs Switch Current

8.3 Additional Application Examples

8.3.1 Test Circuits



- C_{IN1}—100 μF, 25V Aluminum Electrolytic
- C_{IN2}—0.1 μF Ceramic
- T—22 μH, 1:1 Schott #67141450
- D—1N5820
- C_{OUT}—680 μF, 16V Aluminum Electrolytic
- C_C—0.47 μF Ceramic
- R_C—2k

Figure 47. Lm2585-3.3 And Lm2585-5.0

Additional Application Examples (continued)

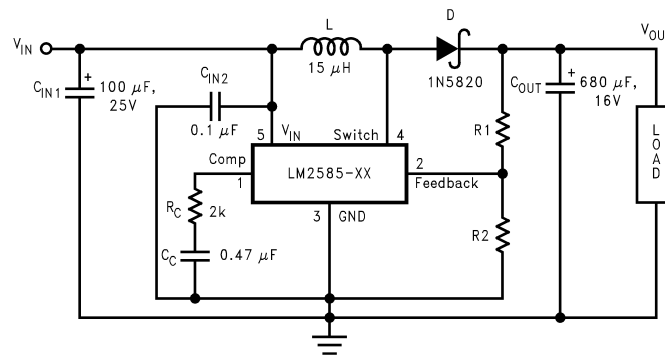

C_{IN1} —100 μ F, 25V Aluminum Electrolytic
 C_{IN2} —0.1 μ F Ceramic
 L —15 μ H, Renco #RL-5472-5
 D —1N5820
 C_{OUT} —680 μ F, 16V Aluminum Electrolytic
 C_C —0.47 μ F Ceramic
 R_C —2k
 For 12V Devices: R_1 = Short (0 Ω) and R_2 = Open
 For ADJ Devices: R_1 = 48.75k, \pm 0.1% and R_2 = 5.62k, \pm 1%

Figure 48. Lm2585-12 And Lm2585-Adj

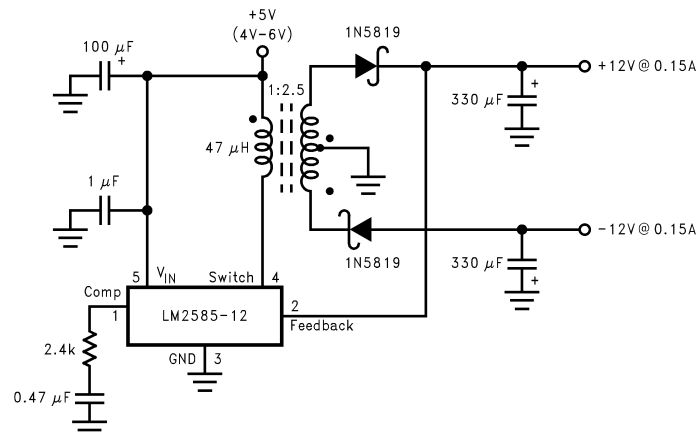

Figure 49. Flyback Regulator

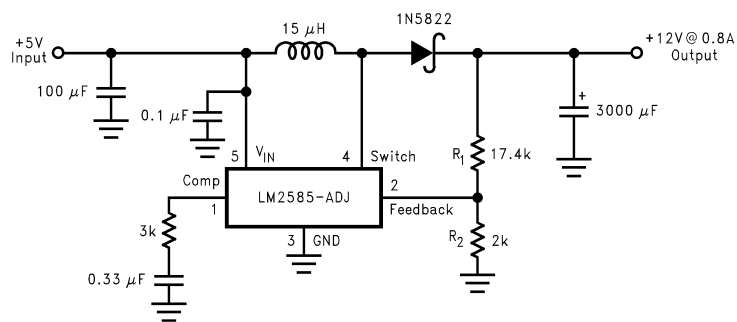

Figure 50. Boost Regulator

9 Layout

9.1 Layout Guidelines

As in any switching regulator, layout is very important. Rapidly switching currents associated with wiring inductance generate voltage transients which can cause problems. For minimal inductance and ground loops, keep the length of the leads and traces as short as possible. Use single point grounding or ground plane construction for best results. Separate the signal grounds from the power grounds (as indicated in [Figure 45](#)). When using the Adjustable version, physically locate the programming resistors as near the regulator IC as possible, to keep the sensitive feedback wiring short.

9.2 Heat Sink/Thermal Considerations

In many cases, no heat sink is required to keep the LM2585 junction temperature within the allowed operating range. For each application, to determine whether or not a heat sink will be required, the following must be identified:

- 1) Maximum ambient temperature (in the application).
- 2) Maximum regulator power dissipation (in the application).
- 3) Maximum allowed junction temperature (125°C for the LM2585). For a safe, conservative design, a temperature approximately 15°C cooler than the maximum junction temperature should be selected (110°C).
- 4) LM2585 package thermal resistances θ_{JA} and θ_{JC} (given in [Thermal Information](#)).

Total power dissipated (P_D) by the LM2585 can be estimated as follows:

Boost:

$$P_D = 0.15\Omega \times \left(\frac{I_{LOAD}}{1-D} \right)^2 \times D + \frac{I_{LOAD}}{50 \times (1-D)} \times D \times V_{IN}$$

Flyback:

$$P_D = 0.15\Omega \times \left(\frac{N \times \Sigma I_{LOAD}}{1-D} \right)^2 \times D + \frac{N \times \Sigma I_{LOAD}}{50 \times (1-D)} \times D \times V_{IN}$$

where

- V_{IN} is the minimum input voltage
 - V_{OUT} is the output voltage
 - N is the transformer turns ratio
 - D is the duty cycle
 - I_{LOAD} is the maximum load current (and ΣI_{LOAD} is the sum of the maximum load currents for multiple-output flyback regulators)
- (7)

The duty cycle is given by:

Boost:

$$D = \frac{V_{OUT} + V_F - V_{IN}}{V_{OUT} + V_F - V_{SAT}} \approx \frac{V_{OUT} - V_{IN}}{V_{OUT}}$$

Flyback:

$$D = \frac{V_{OUT} + V_F}{N(V_{IN} - V_{SAT}) + V_{OUT} + V_F} \approx \frac{V_{OUT}}{N(V_{IN}) + V_{OUT}}$$

where

- V_F is the forward biased voltage of the diode and is typically 0.5V for Schottky diodes and 0.8V for fast recovery diodes
 - V_{SAT} is the switch saturation voltage and can be found in the Characteristic Curves
- (8)

When no heat sink is used, the junction temperature rise is:

$$\Delta T_J = P_D \times \theta_{JA} \quad (9)$$

Adding the junction temperature rise to the maximum ambient temperature gives the actual operating junction temperature:

$$T_J = \Delta T_J + T_A \quad (10)$$

Heat Sink/Thermal Considerations (接下页)

If the operating junction temperature exceeds the maximum junction temperature in item 3 above, then a heat sink is required. When using a heat sink, the junction temperature rise can be determined by the following:

$$\Delta T_J = P_D \times (\theta_{JC} + \theta_{\text{Interface}} + \theta_{\text{Heat Sink}}) \quad (11)$$

Again, the operating junction temperature will be:

$$T_J = \Delta T_J + T_A \quad (12)$$

As before, if the maximum junction temperature is exceeded, a larger heat sink is required (one that has a lower thermal resistance).

Included in the **Switchers Made Simple** design software is a more precise (non-linear) thermal model that can be used to determine junction temperature with different input-output parameters or different component values. It can also calculate the heat sink thermal resistance required to maintain the regulator junction temperature below the maximum operating temperature.

10 器件和文档支持

10.1 器件支持

10.1.1 第三方产品免责声明

TI 发布的与第三方产品或服务有关的信息，不能构成与此类产品或服务或保修的适用性有关的认可，不能构成此类产品或服务单独或与任何 TI 产品或服务一起的表示或认可。

10.1.2 开发支持

10.1.2.1 使用 **WEBENCH®** 工具创建定制设计

单击[此处](#)，使用 LM2585 器件并借助 WEBENCH® 电源设计器创建定制设计方案。

1. 首先输入输入电压 (V_{IN})、输出电压 (V_{OUT}) 和输出电流 (I_{OUT}) 要求。
2. 使用优化器拨盘优化该设计的关键参数，如效率、尺寸和成本。
3. 将生成的设计与德州仪器 (TI) 的其他可行的解决方案进行比较。

WEBENCH 电源设计器可提供定制原理图以及罗列实时价格和组件供货情况的物料清单。

在多数情况下，可执行以下操作：

- 运行电气仿真，观察重要波形以及电路性能
- 运行热性能仿真，了解电路板热性能
- 将定制原理图和布局方案以常用 CAD 格式导出
- 打印设计方案的 PDF 报告并与同事共享

有关 WEBENCH 工具的详细信息，请访问 www.ti.com.cn/WEBENCH。

10.2 接收文档更新通知

要接收文档更新通知，请导航至 TI.com.cn 上的器件产品文件夹。单击右上角的 [通知我](#) 进行注册，即可每周接收产品信息更改摘要。有关更改的详细信息，请查看任何已修订文档中包含的修订历史记录。

10.3 社区资源

The following links connect to TI community resources. Linked contents are provided "AS IS" by the respective contributors. They do not constitute TI specifications and do not necessarily reflect TI's views; see TI's [Terms of Use](#).

TI E2E™ Online Community *TI's Engineer-to-Engineer (E2E) Community*. Created to foster collaboration among engineers. At e2e.ti.com, you can ask questions, share knowledge, explore ideas and help solve problems with fellow engineers.

Design Support *TI's Design Support* Quickly find helpful E2E forums along with design support tools and contact information for technical support.

10.4 商标

E2E is a trademark of Texas Instruments.

WEBENCH is a registered trademark of Texas Instruments.

All other trademarks are the property of their respective owners.

10.5 静电放电警告



ESD 可能会损坏该集成电路。德州仪器 (TI) 建议通过适当的预防措施处理所有集成电路。如果不遵守正确的处理措施和安装程序，可能会损坏集成电路。

ESD 的损坏小至导致微小的性能降级，大至整个器件故障。精密的集成电路可能更容易受到损坏，这是因为非常细微的参数更改都可能会导致器件与其发布的规格不相符。

10.6 Glossary

SLYZ022 — *TI Glossary*.

This glossary lists and explains terms, acronyms, and definitions.

11 机械、封装和可订购信息

以下页面包含机械、封装和可订购信息。这些信息是指定器件的最新可用数据。数据如有变更，恕不另行通知，且不会对此文档进行修订。如需获取此数据表的浏览器版本，请查阅左侧的导航栏。

PACKAGING INFORMATION

Orderable part number	Status (1)	Material type (2)	Package Pins	Package qty Carrier	RoHS (3)	Lead finish/ Ball material (4)	MSL rating/ Peak reflow (5)	Op temp (°C)	Part marking (6)
LM2585S-12/NOPB	Active	Production	DDPAK/ TO-263 (KTT) 5	45 TUBE	ROHS Exempt	SN	Level-3-245C-168 HR	-40 to 125	LM2585S -12 P+
LM2585S-12/NOPB.B	Active	Production	DDPAK/ TO-263 (KTT) 5	45 TUBE	ROHS Exempt	SN	Level-3-245C-168 HR	-40 to 125	LM2585S -12 P+
LM2585S-3.3/NOPB	Active	Production	DDPAK/ TO-263 (KTT) 5	45 TUBE	ROHS Exempt	SN	Level-3-245C-168 HR	-40 to 125	LM2585S -3.3 P+
LM2585S-3.3/NOPB.B	Active	Production	DDPAK/ TO-263 (KTT) 5	45 TUBE	ROHS Exempt	SN	Level-3-245C-168 HR	-40 to 125	LM2585S -3.3 P+
LM2585S-5.0/NOPB	Active	Production	DDPAK/ TO-263 (KTT) 5	45 TUBE	ROHS Exempt	SN	Level-3-245C-168 HR	-40 to 125	LM2585S -5.0 P+
LM2585S-5.0/NOPB.B	Active	Production	DDPAK/ TO-263 (KTT) 5	45 TUBE	ROHS Exempt	SN	Level-3-245C-168 HR	-40 to 125	LM2585S -5.0 P+
LM2585S-ADJ/NOPB	Active	Production	DDPAK/ TO-263 (KTT) 5	45 TUBE	ROHS Exempt	SN	Level-3-245C-168 HR	-40 to 125	LM2585S -ADJ P+
LM2585S-ADJ/NOPB.B	Active	Production	DDPAK/ TO-263 (KTT) 5	45 TUBE	ROHS Exempt	SN	Level-3-245C-168 HR	-40 to 125	LM2585S -ADJ P+
LM2585SX-12/NOPB	Active	Production	DDPAK/ TO-263 (KTT) 5	500 LARGE T&R	ROHS Exempt	SN	Level-3-245C-168 HR	-40 to 125	LM2585S -12 P+
LM2585SX-12/NOPB.B	Active	Production	DDPAK/ TO-263 (KTT) 5	500 LARGE T&R	ROHS Exempt	SN	Level-3-245C-168 HR	-40 to 125	LM2585S -12 P+
LM2585SX-5.0/NOPB	Active	Production	DDPAK/ TO-263 (KTT) 5	500 LARGE T&R	ROHS Exempt	SN	Level-3-245C-168 HR	-40 to 125	LM2585S -5.0 P+
LM2585SX-5.0/NOPB.B	Active	Production	DDPAK/ TO-263 (KTT) 5	500 LARGE T&R	ROHS Exempt	SN	Level-3-245C-168 HR	-40 to 125	LM2585S -5.0 P+
LM2585SX-ADJ/NOPB	Active	Production	DDPAK/ TO-263 (KTT) 5	500 LARGE T&R	ROHS Exempt	SN	Level-3-245C-168 HR	-40 to 125	LM2585S -ADJ P+
LM2585SX-ADJ/NOPB.B	Active	Production	DDPAK/ TO-263 (KTT) 5	500 LARGE T&R	ROHS Exempt	SN	Level-3-245C-168 HR	-40 to 125	LM2585S -ADJ P+
LM2585T-12/NOPB	Active	Production	TO-220 (NDH) 5	45 TUBE	ROHS Exempt	SN	Level-1-NA-UNLIM	-40 to 125	LM2585T -12 P+
LM2585T-12/NOPB.B	Active	Production	TO-220 (NDH) 5	45 TUBE	ROHS Exempt	SN	Level-1-NA-UNLIM	-40 to 125	LM2585T -12 P+

Orderable part number	Status (1)	Material type (2)	Package Pins	Package qty Carrier	RoHS (3)	Lead finish/ Ball material (4)	MSL rating/ Peak reflow (5)	Op temp (°C)	Part marking (6)
LM2585T-3.3/NOPB	Active	Production	TO-220 (NDH) 5	45 TUBE	ROHS Exempt	SN	Level-1-NA-UNLIM	-40 to 125	LM2585T -3.3 P+
LM2585T-3.3/NOPB.B	Active	Production	TO-220 (NDH) 5	45 TUBE	ROHS Exempt	SN	Level-1-NA-UNLIM	-40 to 125	LM2585T -3.3 P+
LM2585T-5.0/NOPB	Active	Production	TO-220 (NDH) 5	45 TUBE	ROHS Exempt	SN	Level-1-NA-UNLIM	-40 to 125	LM2585T -5.0 P+
LM2585T-5.0/NOPB.B	Active	Production	TO-220 (NDH) 5	45 TUBE	ROHS Exempt	SN	Level-1-NA-UNLIM	-40 to 125	LM2585T -5.0 P+
LM2585T-ADJ/NOPB	Active	Production	TO-220 (NDH) 5	45 TUBE	ROHS Exempt	SN	Level-1-NA-UNLIM	-40 to 125	LM2585T -ADJ P+
LM2585T-ADJ/NOPB.B	Active	Production	TO-220 (NDH) 5	45 TUBE	ROHS Exempt	SN	Level-1-NA-UNLIM	-40 to 125	LM2585T -ADJ P+

⁽¹⁾ **Status:** For more details on status, see our [product life cycle](#).

⁽²⁾ **Material type:** When designated, preproduction parts are prototypes/experimental devices, and are not yet approved or released for full production. Testing and final process, including without limitation quality assurance, reliability performance testing, and/or process qualification, may not yet be complete, and this item is subject to further changes or possible discontinuation. If available for ordering, purchases will be subject to an additional waiver at checkout, and are intended for early internal evaluation purposes only. These items are sold without warranties of any kind.

⁽³⁾ **RoHS values:** Yes, No, RoHS Exempt. See the [TI RoHS Statement](#) for additional information and value definition.

⁽⁴⁾ **Lead finish/Ball material:** Parts may have multiple material finish options. Finish options are separated by a vertical ruled line. Lead finish/Ball material values may wrap to two lines if the finish value exceeds the maximum column width.

⁽⁵⁾ **MSL rating/Peak reflow:** The moisture sensitivity level ratings and peak solder (reflow) temperatures. In the event that a part has multiple moisture sensitivity ratings, only the lowest level per JEDEC standards is shown. Refer to the shipping label for the actual reflow temperature that will be used to mount the part to the printed circuit board.

⁽⁶⁾ **Part marking:** There may be an additional marking, which relates to the logo, the lot trace code information, or the environmental category of the part.

Multiple part markings will be inside parentheses. Only one part marking contained in parentheses and separated by a "~" will appear on a part. If a line is indented then it is a continuation of the previous line and the two combined represent the entire part marking for that device.

Important Information and Disclaimer: The information provided on this page represents TI's knowledge and belief as of the date that it is provided. TI bases its knowledge and belief on information provided by third parties, and makes no representation or warranty as to the accuracy of such information. Efforts are underway to better integrate information from third parties. TI has taken and continues to take reasonable steps to provide representative

and accurate information but may not have conducted destructive testing or chemical analysis on incoming materials and chemicals. TI and TI suppliers consider certain information to be proprietary, and thus CAS numbers and other limited information may not be available for release.

In no event shall TI's liability arising out of such information exceed the total purchase price of the TI part(s) at issue in this document sold by TI to Customer on an annual basis.

TAPE AND REEL INFORMATION

QUADRANT ASSIGNMENTS FOR PIN 1 ORIENTATION IN TAPE

*All dimensions are nominal

Device	Package Type	Package Drawing	Pins	SPQ	Reel Diameter (mm)	Reel Width W1 (mm)	A0 (mm)	B0 (mm)	K0 (mm)	P1 (mm)	W (mm)	Pin1 Quadrant
LM2585SX-12/NOPB	DDPAK/ TO-263	KTT	5	500	330.0	24.4	10.75	14.85	5.0	16.0	24.0	Q2
LM2585SX-5.0/NOPB	DDPAK/ TO-263	KTT	5	500	330.0	24.4	10.75	14.85	5.0	16.0	24.0	Q2
LM2585SX-ADJ/NOPB	DDPAK/ TO-263	KTT	5	500	330.0	24.4	10.75	14.85	5.0	16.0	24.0	Q2

TAPE AND REEL BOX DIMENSIONS



*All dimensions are nominal

Device	Package Type	Package Drawing	Pins	SPQ	Length (mm)	Width (mm)	Height (mm)
LM2585SX-12/NOPB	DDPAK/TO-263	KTT	5	500	356.0	356.0	45.0
LM2585SX-5.0/NOPB	DDPAK/TO-263	KTT	5	500	356.0	356.0	45.0
LM2585SX-ADJ/NOPB	DDPAK/TO-263	KTT	5	500	356.0	356.0	45.0

TUBE

*All dimensions are nominal

Device	Package Name	Package Type	Pins	SPQ	L (mm)	W (mm)	T (μm)	B (mm)
LM2585S-12/NOPB	KTT	TO-263	5	45	502	25	8204.2	9.19
LM2585S-12/NOPB.B	KTT	TO-263	5	45	502	25	8204.2	9.19
LM2585S-3.3/NOPB	KTT	TO-263	5	45	502	25	8204.2	9.19
LM2585S-3.3/NOPB.B	KTT	TO-263	5	45	502	25	8204.2	9.19
LM2585S-5.0/NOPB	KTT	TO-263	5	45	502	25	8204.2	9.19
LM2585S-5.0/NOPB.B	KTT	TO-263	5	45	502	25	8204.2	9.19
LM2585S-ADJ/NOPB	KTT	TO-263	5	45	502	25	8204.2	9.19
LM2585S-ADJ/NOPB.B	KTT	TO-263	5	45	502	25	8204.2	9.19
LM2585T-12/NOPB	NDH	TO-220	5	45	502	30	30048.2	10.74
LM2585T-12/NOPB.B	NDH	TO-220	5	45	502	30	30048.2	10.74
LM2585T-3.3/NOPB	NDH	TO-220	5	45	502	30	30048.2	10.74
LM2585T-3.3/NOPB.B	NDH	TO-220	5	45	502	30	30048.2	10.74
LM2585T-5.0/NOPB	NDH	TO-220	5	45	502	30	30048.2	10.74
LM2585T-5.0/NOPB.B	NDH	TO-220	5	45	502	30	30048.2	10.74
LM2585T-ADJ/NOPB	NDH	TO-220	5	45	502	30	30048.2	10.74
LM2585T-ADJ/NOPB.B	NDH	TO-220	5	45	502	30	30048.2	10.74

NDH0005D



T05D (REV A)

KTT0005B

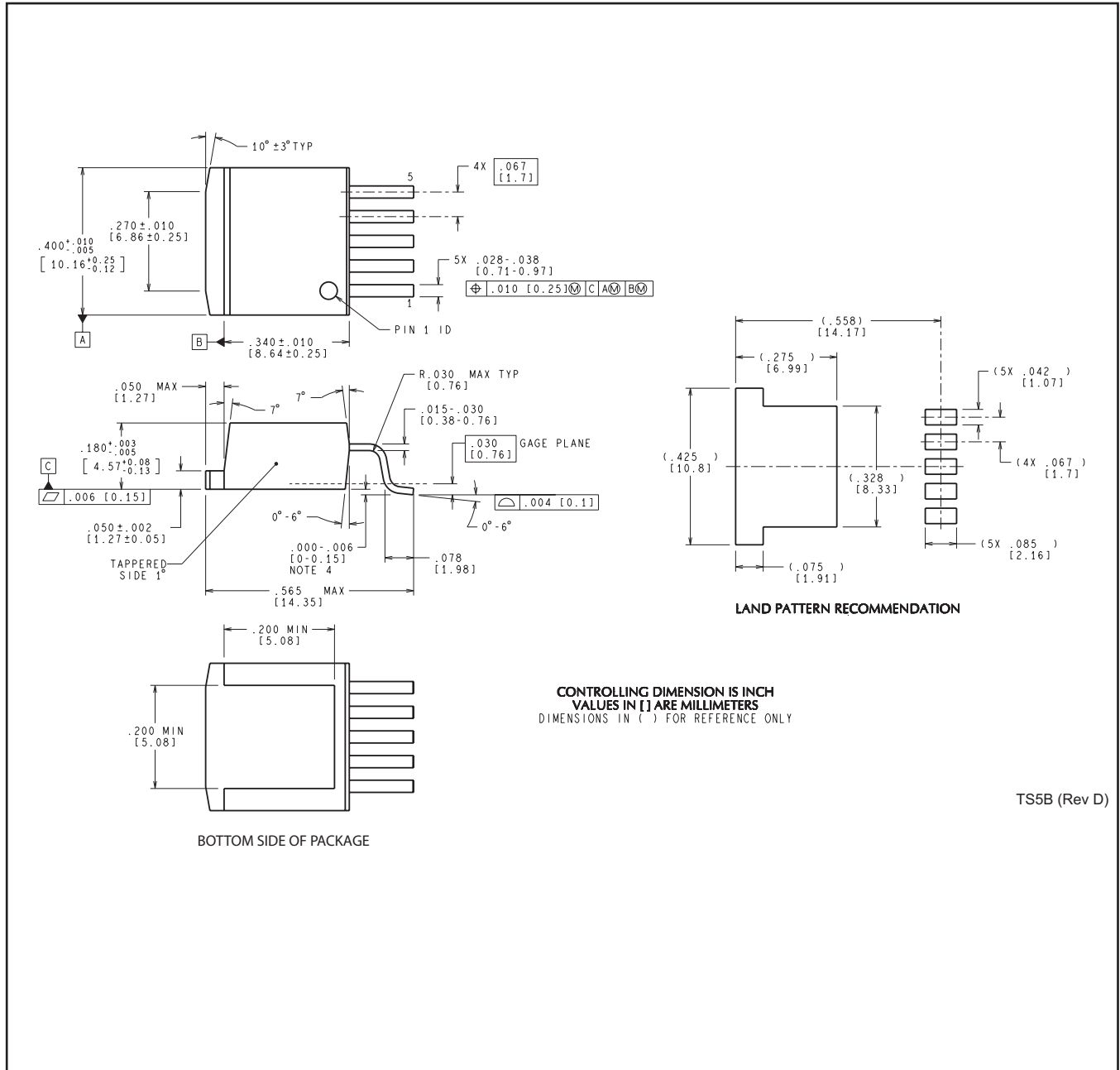

重要通知和免责声明

TI“按原样”提供技术和可靠性数据（包括数据表）、设计资源（包括参考设计）、应用或其他设计建议、网络工具、安全信息和其他资源，不保证没有瑕疵且不做任何明示或暗示的担保，包括但不限于对适销性、某特定用途方面的适用性或不侵犯任何第三方知识产权的暗示担保。

这些资源可供使用 TI 产品进行设计的熟练开发人员使用。您将自行承担以下全部责任：(1) 针对您的应用选择合适的 TI 产品，(2) 设计、验证并测试您的应用，(3) 确保您的应用满足相应标准以及任何其他功能安全、信息安全、监管或其他要求。

这些资源如有变更，恕不另行通知。TI 授权您仅可将这些资源用于研发本资源所述的 TI 产品的相关应用。严禁以其他方式对这些资源进行复制或展示。您无权使用任何其他 TI 知识产权或任何第三方知识产权。您应全额赔偿因在这些资源的使用中对 TI 及其代表造成的任何索赔、损害、成本、损失和债务，TI 对此概不负责。

TI 提供的产品受 [TI 的销售条款](#) 或 [ti.com](#) 上其他适用条款/TI 产品随附的其他适用条款的约束。TI 提供这些资源并不会扩展或以其他方式更改 TI 针对 TI 产品发布的适用的担保或担保免责声明。

TI 反对并拒绝您可能提出的任何其他或不同的条款。

邮寄地址：Texas Instruments, Post Office Box 655303, Dallas, Texas 75265
版权所有 © 2025，德州仪器 (TI) 公司