

ISO7421-EP 低功耗双路数字隔离器

1 特性

- 最高信号传输速率：1Mbps
- 低功耗，每通道 I_{CC} 典型值（3.3V 工作电压）：1.5mA
- 低传播延迟 - 9ns 典型值
- 低偏移 - 300ps 典型值
- 宽 T_A 温度范围：-55°C 至 136°C
- 50kV/ μ s 瞬态抗扰度，典型值
- 在额定电压上超过 25 年的隔离装置完好性
- 可由 3.3V 和 5V 电源及逻辑电平供电
- 3.3V 和 5V 电平转换
- 窄体小尺寸集成电路 (SOIC)-8 封装
- 安全及管理批准：
 - 符合 DIN V VDE V 0884-10 和 DIN EN 61010-1 标准的 4242 V_{PK} 隔离
 - 符合 UL 1577 标准且长达 1 分钟的 2500 V_{RMS} 隔离
 - CSA 组件接受通知 5A, IEC 60950-1 和 IEC 61010-1 标准
 - 通过 GB4943.1-2011 CQC 认证

2 应用

- 是下列应用中光耦合器的替代产品：
 - 工业现场总线
 - Profibus 现场总线
 - Modbus 协议
 - DeviceNet™ 数据总线
 - 伺服控制接口
 - 电机控制
 - 电源
 - 电池组

3 说明

ISO7421-EP 器件可提供符合 UL 标准的长达 1 分钟且高达 2500 V_{RMS} 的电流隔离。ISO7421-EP 器件有两个隔离通道。每个隔离通道的逻辑输入和输出缓冲器均由二氧化硅 (SiO_2) 绝缘隔栅分离开来。与隔离式电源一起使用时，此器件可防止数据总线或者其他电路上的噪声电流进入本地接地端并干扰或损坏敏感电路。

此器件具有晶体管-晶体管逻辑电路 (TTL) 输入阈值，并且需要两个电源电压，3.3 或 5V，或者任意组合。当由一个 3.3V 电源供电时，所有输入均为 5V 耐压。

ISO7421-EP 器件的额定信号传输速率高达 1Mbps。由于其响应时间短，在大多数情况下，此器件还将发送脉宽更短的数据。如果需要，设计人员应添加外部滤波来去除输入脉冲持续时间 < 20ns 的寄生信号。

器件信息(1)

部件号	封装	封装尺寸 (标称值)
ISO7421-EP	SOIC (8)	4.90mm x 3.91mm

(1) 要了解所有可用封装，请见数据表末尾的可订购产品附录。

数字电容隔离器的概念框图

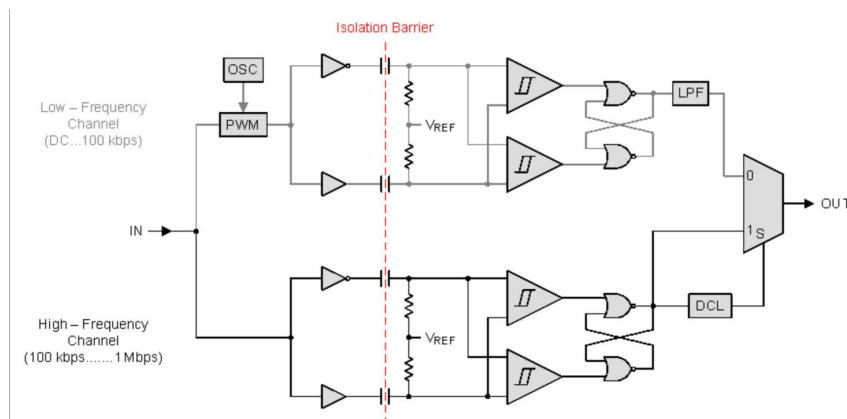

目录

1	特性	1	6.13	Switching Characteristics: V_{CC1} and V_{CC2} at 3.3 V $\pm 10\%$	7
2	应用	1	6.14	Typical Characteristics	8
3	说明	1	7	Parameter Measurement Information	9
4	修订历史记录	2	8	Detailed Description	10
5	Pin Configuration and Functions	3	8.1	Overview	10
6	Specifications	4	8.2	Functional Block Diagram	10
6.1	Absolute Maximum Ratings	4	8.3	Feature Description	11
6.2	ESD Ratings	4	8.4	Device Functional Modes	13
6.3	Recommended Operating Conditions	4	9	Application and Implementation	14
6.4	Thermal Information	4	9.1	Application Information	14
6.5	Electrical Characteristics: V_{CC1} and V_{CC2} at 5 V $\pm 10\%$	5	9.2	Typical Application	14
6.6	Electrical Characteristics: V_{CC1} at 5 V $\pm 10\%$, V_{CC2} at 3.3 V $\pm 10\%$	5	10	Power Supply Recommendations	16
6.7	Electrical Characteristics: V_{CC1} at 3.3 V $\pm 10\%$, V_{CC2} at 5 V $\pm 10\%$	6	11	Layout	16
6.8	Electrical Characteristics: V_{CC1} and V_{CC2} at 3.3 V $\pm 10\%$	6	11.1	Layout Guidelines	16
6.9	Power Dissipation	6	11.2	Layout Example	16
6.10	Switching Characteristics: V_{CC1} and V_{CC2} at 5 V $\pm 10\%$	7	12	器件和文档支持	17
6.11	Switching Characteristics: V_{CC1} at 5 V $\pm 10\%$, V_{CC2} at 3.3 V $\pm 10\%$	7	12.1	文档支持	17
6.12	Switching Characteristics: V_{CC1} at 3.3 V $\pm 10\%$, V_{CC2} at 5 V $\pm 10\%$	7	12.2	社区资源	17
			12.3	商标	17
			12.4	静电放电警告	17
			12.5	Glossary	17
			13	机械、封装和可订购信息	17

4 修订历史记录

日期	修订版本	注释
2015 年 12 月	*	最初发布版本。

5 Pin Configuration and Functions

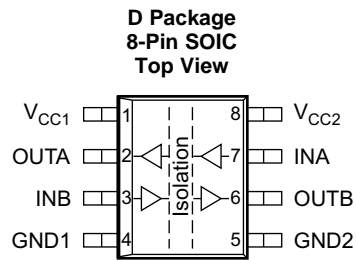

Pin Functions

PIN		I/O	DESCRIPTION
NAME	NO.		
GND1	4	—	Ground connection for V_{CC1}
GND2	5	—	Ground connection for V_{CC2}
INA	7	I	Input, channel A
INB	3	I	Input, channel B
OUTA	2	O	Output, channel A
OUTB	6	O	Output, channel B
V_{CC1}	1	—	Power supply, V_{CC1}
V_{CC2}	8	—	Power supply, V_{CC2}

6 Specifications

6.1 Absolute Maximum Ratings

see ⁽¹⁾

		MIN	MAX	UNIT
V _{CC}	Supply voltage ⁽²⁾ , V _{CC1} , V _{CC2}	-0.5	6	V
V _I	Voltage at IN, OUT	-0.5	V _{CC} + 0.5 ⁽³⁾	V
I _O	Output current	-15	15	mA
T _{J(max)}	Maximum junction temperature		150	°C
T _{stg}	Storage temperature	-65	150	°C

- (1) Stresses beyond those listed under *Absolute Maximum Ratings* may cause permanent damage to the device. These are stress ratings only and functional operation of the device at these or any other conditions beyond those indicated under *Recommended Operating Conditions* is not implied. Exposure to absolute-maximum-rated conditions for extended periods may affect device reliability.
- (2) All voltage values except differential I/O bus voltages are with respect to network ground terminal and are peak voltage values.
- (3) Maximum voltage must not exceed 6 V.

6.2 ESD Ratings

		VALUE	UNIT
V _(ESD)	Electrostatic discharge	Human body model (HBM), per ANSI/ESDA/JEDEC JS-001 ⁽¹⁾	±4000
		Field-induced charged-device model, JEDEC Standard 22, Test Method C101	±1500
		Machine model, ANSI/ESDS5.2-1996	±200

- (1) JEDEC document JEP155 states that 500-V HBM allows safe manufacturing with a standard ESD control process.

6.3 Recommended Operating Conditions

		MIN	NOM	MAX	UNIT
V _{CC1} , V _{CC2}	Supply voltage - 3.3-V operation	3	3.3	3.6	V
	Supply voltage - 5-V operation	4.5	5	5.5	
I _{OH}	High-level output current	-4			mA
I _{OL}	Low-level output current			4	mA
V _{IH}	High-level input voltage	2		5.25	V
V _{IL}	Low-level input voltage	0		0.8	V
1/t _{ui}	Signaling rate	0		1	Mbps
t _{ui}	Input pulse duration	1			us
T _J ⁽¹⁾	Junction temperature	-55		136	°C

- (1) To maintain the recommended operating conditions for T_J, see the [Thermal Information](#).

6.4 Thermal Information

THERMAL METRIC ⁽¹⁾		ISO7421-EP		UNIT
		D (SOIC)		
		8 PINS		
R _{θJA}	Junction-to-ambient thermal resistance	Low-K Board	212	°C/W
		High-K Board	116.6	
R _{θJC(top)}	Junction-to-case (top) thermal resistance		71.6	°C/W
R _{θJB}	Junction-to-board thermal resistance		57.3	°C/W
ψ _{JT}	Junction-to-top characterization parameter		28.3	°C/W
ψ _{JB}	Junction-to-board characterization parameter		56.8	°C/W

- (1) For more information about traditional and new thermal metrics, see the *Semiconductor and IC Package Thermal Metrics* application report, [SPRA953](#).

6.5 Electrical Characteristics: V_{CC1} and V_{CC2} at 5 V \pm 10%

 $T_J = -55^\circ\text{C}$ to 136°C

PARAMETER		TEST CONDITIONS		MIN	TYP	MAX	UNIT
V_{OH}	High-level output voltage	$I_{OH} = -4$ mA; see Figure 6.		$V_{CCO}^{(1)} - 0.8$	4.6		V
		$I_{OH} = -20$ μ A; see Figure 6.		$V_{CCO} - 0.1$	5		
V_{OL}	Low-level output voltage	$I_{OL} = 4$ mA; see Figure 6.			0.2	0.4	V
		$I_{OL} = 20$ μ A; see Figure 6.			0	0.1	
$V_{I(HYS)}$	Input threshold voltage hysteresis				400		mV
I_{IH}	High-level input current	INx at 0 V or $V_{CC1}^{(1)}$				10	μ A
I_{IL}	Low-level input current				-10		μ A
CMTI	Common-mode transient immunity	$V_I = V_{CC1}$ or 0 V; see Figure 8.		25	50		kV/ μ s
SUPPLY CURRENT (ALL INPUTS SWITCHING WITH SQUARE WAVE CLOCK SIGNAL FOR DYNAMIC ICC MEASUREMENT)							
I_{CC1}	Supply current for V_{CC1}	DC to 1 Mbps	$V_I = V_{CC1}$ or 0 V, 15 pF load		2	4	mA
I_{CC2}	Supply current for V_{CC2}				2	4	

(1) V_{CC1} = Input-side power supply, V_{CCO} = Output-side power supply

6.6 Electrical Characteristics: V_{CC1} at 5 V \pm 10%, V_{CC2} at 3.3 V \pm 10%

 $T_J = -55^\circ\text{C}$ to 136°C

PARAMETER		TEST CONDITIONS		MIN	TYP	MAX	UNIT
V_{OH}	High-level output voltage	$I_{OH} = -4$ mA; see Figure 6.	5-V side	$V_{CCO}^{(1)} - 0.8$	4.6		V
			3.3-V side	$V_{CCO} - 0.4$	3		
		$I_{OH} = -20$ μ A; see Figure 6.		$V_{CCO} - 0.1$	V_{CC}		
V_{OL}	Low-level output voltage	$I_{OL} = 4$ mA; see Figure 6.			0.2	0.4	V
		$I_{OL} = 20$ μ A; see Figure 6.			0	0.1	
$V_{I(HYS)}$	Input threshold voltage hysteresis				400		mV
I_{IH}	High-level input current	INx at 0 V or $V_{CC1}^{(1)}$				10	μ A
I_{IL}	Low-level input current				-10		μ A
CMTI	Common-mode transient immunity	$V_I = V_{CC1}$ or 0 V; see Figure 8.		25	40		kV/ μ s
SUPPLY CURRENT (ALL INPUTS SWITCHING WITH SQUARE WAVE CLOCK SIGNAL FOR DYNAMIC ICC MEASUREMENT)							
I_{CC1}	Supply current for V_{CC1}	DC to 1 Mbps	$V_I = V_{CC1}$ or 0 V, 15 pF load		2	4	mA
I_{CC2}	Supply current for V_{CC2}				1.5	3.5	

(1) V_{CC1} = Input-side power supply, V_{CCO} = Output-side power supply

6.7 Electrical Characteristics: V_{CC1} at 3.3 V $\pm 10\%$, V_{CC2} at 5 V $\pm 10\%$
 $T_J = -55^\circ\text{C}$ to 136°C

PARAMETER		TEST CONDITIONS		MIN	TYP	MAX	UNIT
V_{OH}	High-level output voltage	$I_{OH} = -4$ mA; see Figure 6.	5-V side	$V_{CCO}^{(1)} - 0.8$	4.6		V
			3.3-V side	$V_{CCO} - 0.4$	3		
		$I_{OH} = -20$ μA ; see Figure 6	$V_{CCO} - 0.1$	V_{CC}			
V_{OL}	Low-level output voltage	$I_{OL} = 4$ mA; see Figure 6.			0.2	0.4	V
		$I_{OL} = 20$ μA ; see Figure 6.			0	0.1	
$V_{I(HYS)}$	Input threshold voltage hysteresis				400		mV
I_{IH}	High-level input current	I_{Nx} at 0 V or $V_{CC1}^{(1)}$				10	μA
I_{IL}	Low-level input current				-10		μA
CMTI	Common-mode transient immunity	$V_I = V_{CC1}$ or 0 V; see Figure 8.		25	40		kV/ μs
SUPPLY CURRENT (ALL INPUTS SWITCHING WITH SQUARE WAVE CLOCK SIGNAL FOR DYNAMIC ICC MEASUREMENT)							
I_{CC1}	Supply current for V_{CC1}	DC to 1 Mbps	$V_I = V_{CC1}$ or 0 V, 15 pF load		1.5	3.5	mA
I_{CC2}	Supply current for V_{CC2}				2	4	

 (1) V_{CC1} = Input-side power supply, V_{CCO} = Output-side power supply

6.8 Electrical Characteristics: V_{CC1} and V_{CC2} at 3.3 V $\pm 10\%$
 $T_J = -55^\circ\text{C}$ to 136°C

PARAMETER		TEST CONDITIONS		MIN	TYP	MAX	UNIT
V_{OH}	High-level output voltage	$I_{OH} = -4$ mA; see Figure 6.		$V_{CCO}^{(1)} - 0.4$	3		V
		$I_{OH} = -20$ μA ; see Figure 6.		$V_{CCO} - 0.1$	3.3		
V_{OL}	Low-level output voltage	$I_{OL} = 4$ mA; see Figure 6.			0.2	0.4	V
		$I_{OL} = 20$ μA ; see Figure 6.			0	0.1	
$V_{I(HYS)}$	Input threshold voltage hysteresis				400		mV
I_{IH}	High-level input current	I_{Nx} at 0 V or $V_{CC1}^{(1)}$				10	μA
I_{IL}	Low-level input current				-10		μA
CMTI	Common-mode transient immunity	$V_I = V_{CC1}$ or 0 V; see Figure 8 .		25	40		kV/ μs
SUPPLY CURRENT (ALL INPUTS SWITCHING WITH SQUARE WAVE CLOCK SIGNAL FOR DYNAMIC ICC MEASUREMENT)							
I_{CC1}	Supply current for V_{CC1}	DC to 1 Mbps	$V_I = V_{CC1}$ or 0 V, 15 pF load		1.5	3.5	mA
I_{CC2}	Supply current for V_{CC2}				1.5	3.5	

 (1) V_{CC1} = Input-side power supply, V_{CCO} = Output-side power supply

6.9 Power Dissipation

THERMAL METRIC			ISO7421-EP	UNIT
			D (SOIC)	
			8 PINS	
P_D	Device power dissipation	$V_{CC1} = V_{CC2} = 5.25$ V, $T_J = 150^\circ\text{C}$, $C_L = 15$ pF Input a 1-Mbps 50% duty-cycle square wave	55	mW

6.10 Switching Characteristics: V_{CC1} and V_{CC2} at 5 V $\pm 10\%$

 $T_J = -55^\circ\text{C}$ to 136°C

PARAMETER		TEST CONDITIONS	MIN	TYP	MAX	UNIT
t_{PLH} , t_{PHL}	Propagation delay time	See Figure 6.		9	14	ns
PWD ⁽¹⁾	Pulse width distortion $ t_{PHL} - t_{PLH} $			0.3	4	ns
$t_{sk(pp)}$	Part-to-part skew time				4.9	ns
$t_{sk(o)}$	Channel-to-channel output skew time				3.6	ns
t_r	Output signal rise time	See Figure 6.		1		ns
t_f	Output signal fall time			1		ns
t_{fs}	Fail-safe output delay time from input power loss	See Figure 7.		6		μs

(1) Also known as pulse skew.

6.11 Switching Characteristics: V_{CC1} at 5 V $\pm 10\%$, V_{CC2} at 3.3 V $\pm 10\%$

 $T_J = -55^\circ\text{C}$ to 136°C

PARAMETER		TEST CONDITIONS	MIN	TYP	MAX	UNIT
t_{PLH} , t_{PHL}	Propagation delay time	See Figure 6.		10	18.5	ns
PWD ⁽¹⁾	Pulse width distortion $ t_{PHL} - t_{PLH} $			0.5	6	ns
$t_{sk(pp)}$	Part-to-part skew time				6.3	ns
$t_{sk(o)}$	Channel-to-channel output skew time				7	ns
t_r	Output signal rise time	See Figure 6.		2		ns
t_f	Output signal fall time			2		ns
t_{fs}	Fail-safe output delay time from input power loss	See Figure 7.		6		μs

(1) Also known as pulse skew.

6.12 Switching Characteristics: V_{CC1} at 3.3 V $\pm 10\%$, V_{CC2} at 5 V $\pm 10\%$

 $T_J = -55^\circ\text{C}$ to 136°C

PARAMETER		TEST CONDITIONS	MIN	TYP	MAX	UNIT
t_{PLH} , t_{PHL}	Propagation delay time	See Figure 6.		10	21	ns
PWD ⁽¹⁾	Pulse width distortion $ t_{PHL} - t_{PLH} $			0.5	4.5	ns
$t_{sk(pp)}$	Part-to-part skew time				8.5	ns
$t_{sk(o)}$	Channel-to-channel output skew time				10.8	ns
t_r	Output signal rise time	See Figure 6.		2		ns
t_f	Output signal fall time			2		ns
t_{fs}	Fail-safe output delay time from input power loss	See Figure 7.		6		μs

(1) Also known as pulse skew.

6.13 Switching Characteristics: V_{CC1} and V_{CC2} at 3.3 V $\pm 10\%$

 $T_J = -55^\circ\text{C}$ to 136°C

PARAMETER		TEST CONDITIONS	MIN	TYP	MAX	UNIT
t_{PLH} , t_{PHL}	Propagation delay time	See Figure 6.		12	22.5	ns
PWD ⁽¹⁾	Pulse width distortion $ t_{PHL} - t_{PLH} $			1	5.2	ns
$t_{sk(pp)}$	Part-to-part skew time				6.8	ns
$t_{sk(o)}$	Channel-to-channel output skew time				7.8	ns
t_r	Output signal rise time	See Figure 6.		2		ns
t_f	Output signal fall time			2		ns
t_{fs}	Fail-safe output delay time from input power loss	See Figure 7.		6		μs

(1) Also known as pulse skew.

6.14 Typical Characteristics

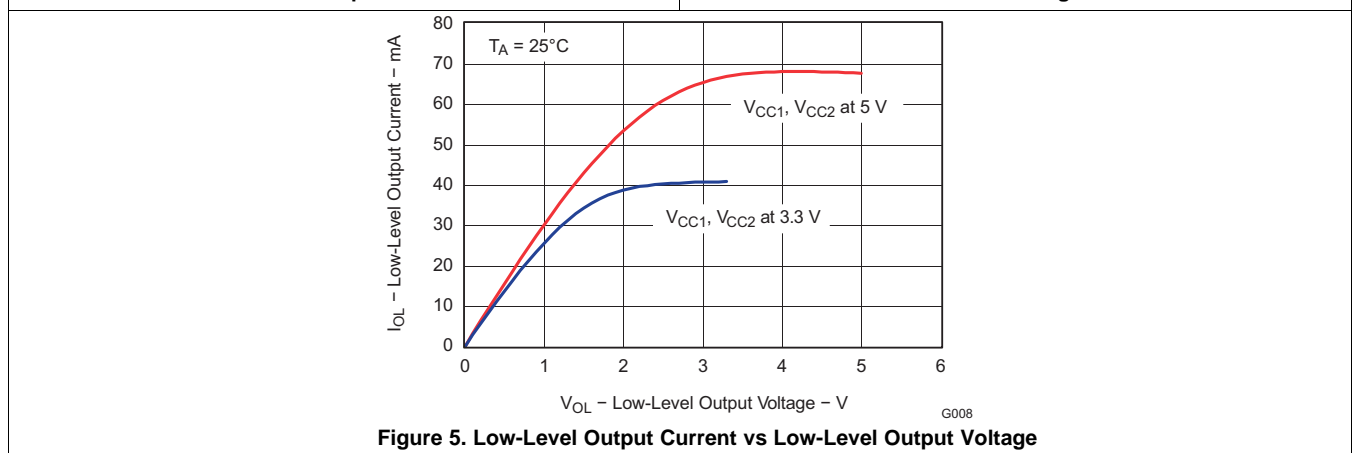
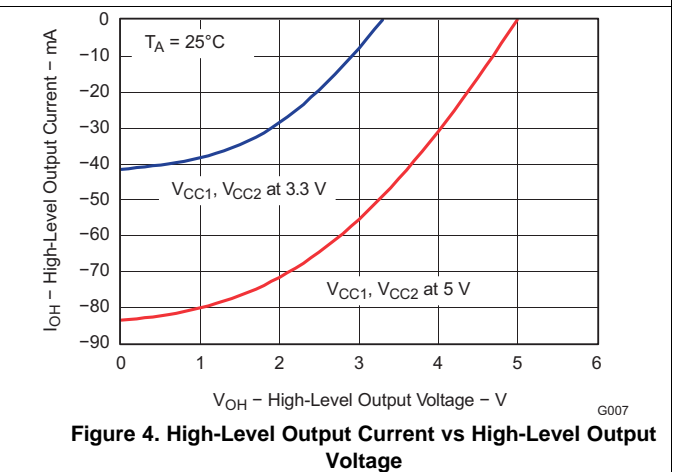
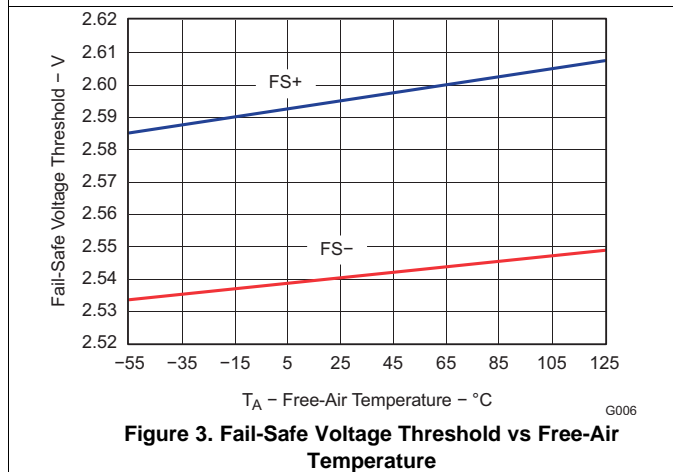
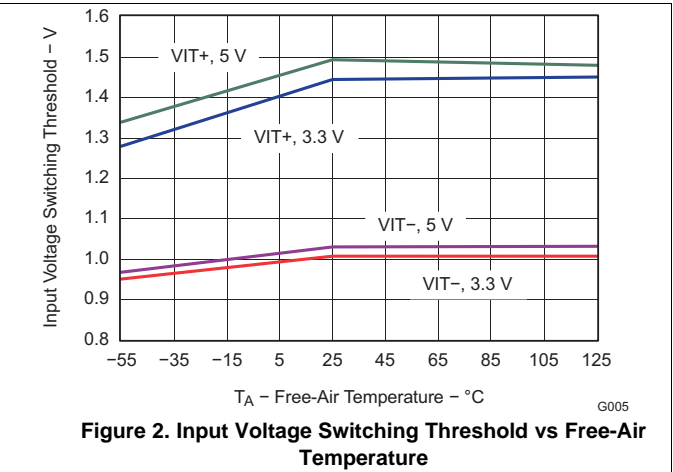
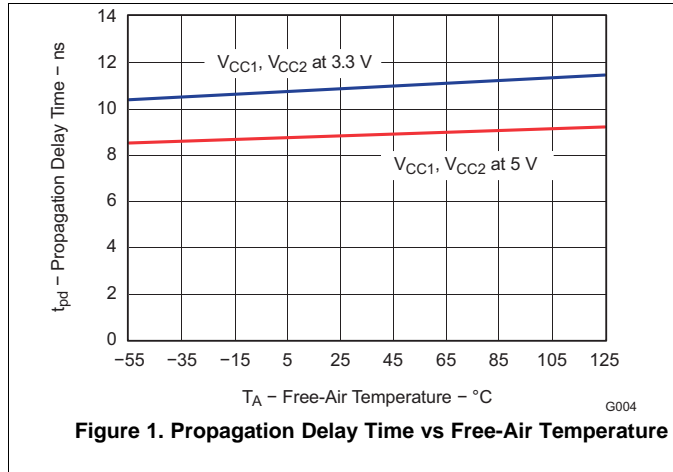

7 Parameter Measurement Information

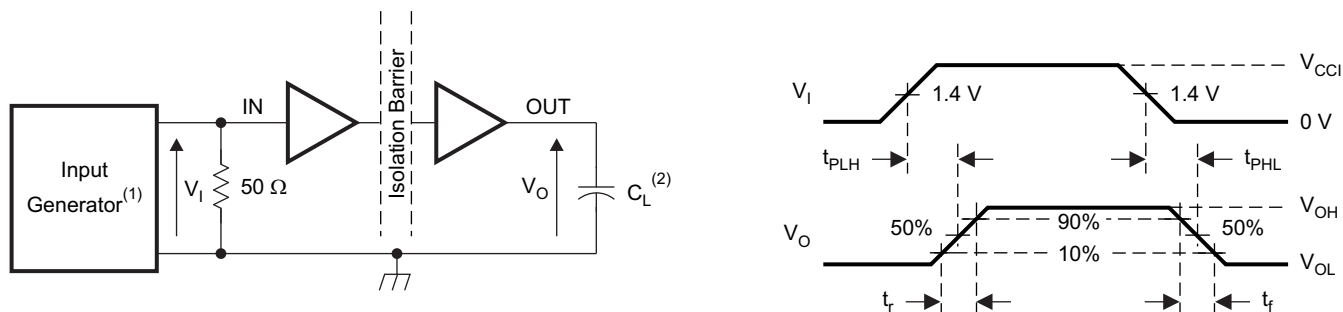

- (1) The input pulse is supplied by a generator having the following characteristics: PRR \leq 50 kHz, 50% duty cycle, $t_r \leq 3$ ns, $t_f \leq 3$ ns, $Z_o = 50 \Omega$. At the input, a 50- Ω resistor is required to terminate the Input Generator signal. It is not needed in actual application.
- (2) $C_L = 15$ pF and includes instrumentation and fixture capacitance within $\pm 20\%$.

Figure 6. Switching Characteristic Test Circuit and Voltage Waveforms

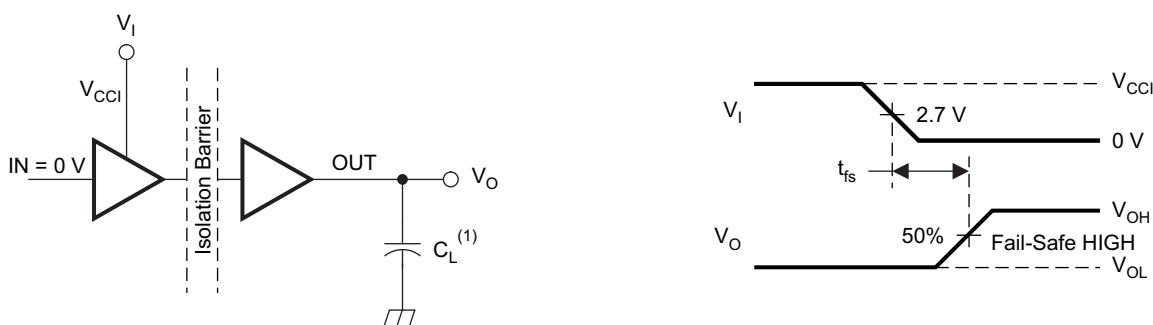

- (1) $C_L = 15$ pF $\pm 20\%$ includes instrumentation and fixture capacitance.

Figure 7. Fail-Safe Output Delay-Time Test Circuit and Voltage Waveforms

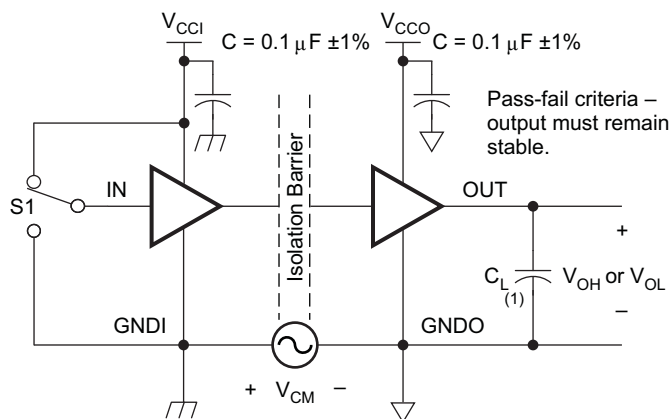

- (1) $C_L = 15$ pF and includes instrumentation and fixture capacitance within $\pm 20\%$.

Figure 8. Common-Mode Transient Immunity Test Circuit

8 Detailed Description

8.1 Overview

The ISO7421 digital isolator has two isolated channels. The ISO7421 provides galvanic isolation up to 2500VRMS for one minute per UL. The isolator in Figure 9 is based on a capacitive isolation barrier technique. The I/O channel of the device consists of two internal data channels, a high-frequency channel (HF) with a bandwidth from 100 kbps up to 1 Mbps, and a low-frequency channel (LF) covering the range from 100 kbps down to DC. In principle, a single-ended input signal entering the HF-channel is split into a differential signal via the inverter gate at the input. The following capacitor-resistor networks differentiate the signal into transients, which then are converted into differential pulses by two comparators. The comparator outputs drive a NOR-gate flip-flop whose output feeds an output multiplexer. A decision logic (DCL) at the driving output of the flip-flop measures the durations between signal transients. If the duration between two consecutive transients exceeds a certain time limit, (as in the case of a low-frequency signal), the DCL forces the output-multiplexer to switch from the high- to the low-frequency channel.

Because low-frequency input signals require the internal capacitors to assume prohibitively large values, these signals are pulse-width modulated (PWM) with the carrier frequency of an internal oscillator, thus creating a sufficiently high frequency signal, capable of passing the capacitive barrier. As the input is modulated, a low-pass filter (LPF) is needed to remove the high-frequency carrier from the actual data before passing it on to the output multiplexer.

8.2 Functional Block Diagram

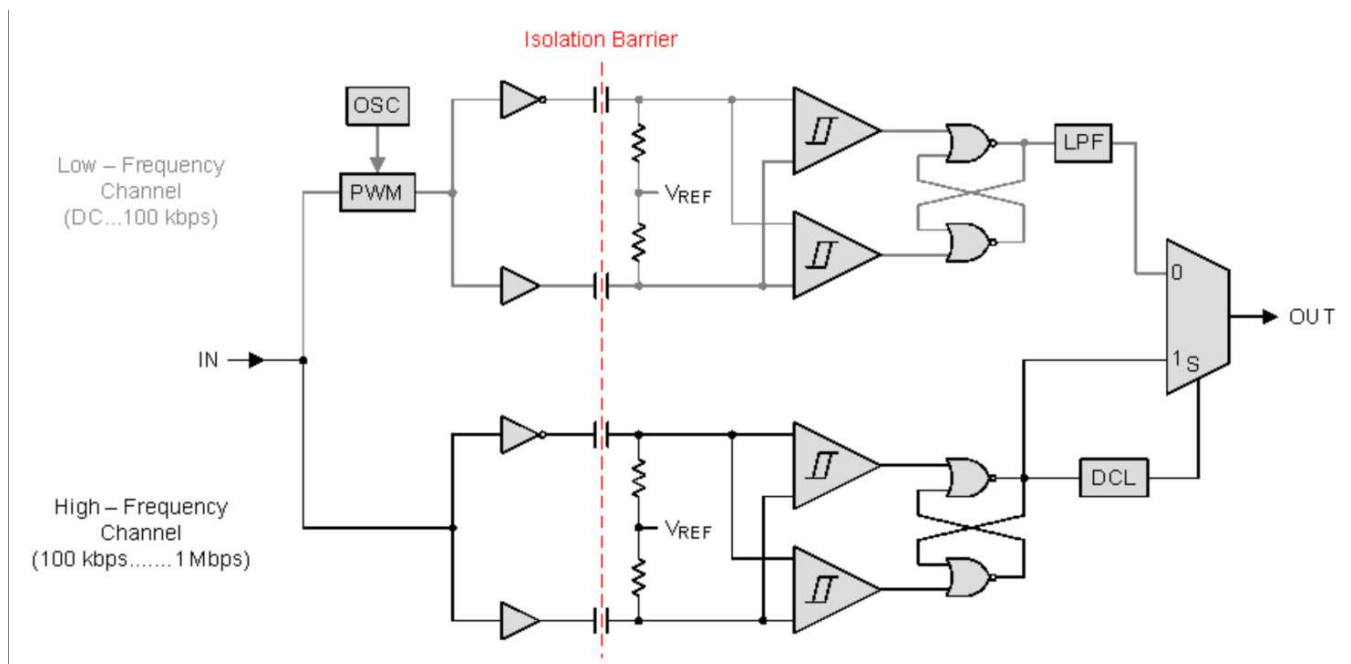

Figure 9. Conceptual Block Diagram of a Digital Capacitive Isolator

8.3 Feature Description

8.3.1 Insulation Characteristics

Over recommended operating conditions (unless otherwise noted)

PARAMETER ⁽¹⁾		TEST CONDITIONS	SPECIFICATION	UNIT
DIN V VDE V 0884-10 (VDE V 0884-10):2006-12				
V _{IORM}	Maximum working insulation voltage		566	V _{PK}
V _{PR}	Input-to-output test voltage	t = 1 s (100% production), partial discharge 5 pC	1062	V _{PK}
V _{IOTM}	Transient overvoltage	t = 60 s (qualification)	4242	V _{PK}
		t = 1 s (100% production)		
R _S	Insulation resistance	V _{IO} = 500 V at T _S	>10 ⁹	Ω
	Pollution degree		2	
UL 1577				
V _{ISO}	Isolation voltage per UL	V _{TEST} = V _{ISO} = 2500 V _{RMS} , t = 60 s (qualification) V _{TEST} = 1.2 x V _{ISO} = 3000 V _{RMS} , t = 1 s (100% production)	2500	V _{RMS}

(1) Climatic Classification 40/125/21

Table 1. IEC 60664-1 Ratings Table

PARAMETER	TEST CONDITIONS	SPECIFICATION
Material group		II
Installation classification	Rated mains voltage ≤ 150 V _{RMS}	I–IV
	Rated mains voltage ≤ 300 V _{RMS}	I–III

8.3.2 Package Characteristics

Over recommended operating conditions (unless otherwise noted)

PARAMETER		TEST CONDITIONS	MIN	TYP	MAX	UNIT
L(I01)	Minimum air gap (clearance)	Shortest terminal-to-terminal distance through air	4			mm
L(I02)	Minimum external tracking (creepage)	Shortest terminal-to-terminal distance across the package surface	4			mm
CTI	Tracking resistance (comparative tracking index)	DIN EN 60112 (VDE 0303-11); IEC 60112	>400			V
DTI	Distance through the insulation	Minimum internal gap (internal clearance)	0.014			mm
R _{IO}	Isolation resistance, input to output ⁽¹⁾	V _{IO} = 500 V, T _A = 25°C	>10 ¹²			Ω
		V _{IO} = 500 V, 100°C ≤ T _A ≤ max	>10 ¹¹			Ω
C _{IO}	Barrier capacitance, input to output ⁽¹⁾	V _{IO} = 0.4 sin (2πft), f = 1 MHz		1		pF
C _I	Input capacitance ⁽²⁾	V _I = V _{CC} /2 + 0.4 sin (2πft), f = 1 MHz, V _{CC} = 5 V		1		pF

(1) All pins on each side of the barrier tied together creating a two-terminal device.

(2) Measured from input pin to ground.

NOTE

Creepage and clearance requirements should be applied according to the specific equipment isolation standards of an application. Care should be taken to maintain the creepage and clearance distance of a board design to ensure that the mounting pads of the isolator on the printed-circuit board do not reduce this distance.

Creepage and clearance on a printed-circuit board become equal in certain cases. Techniques such as inserting grooves and/or ribs on a printed circuit board are used to help increase these specifications.

8.3.3 Safety Limiting Values

Safety limiting intends to prevent potential damage to the isolation barrier upon failure of input or output circuitry. A failure of the I/O can allow low resistance to ground or the supply and, without current limiting, dissipate sufficient power to overheat the die and damage the isolation barrier, potentially leading to secondary system failures.

PARAMETER		TEST CONDITIONS	MIN	TYP	MAX	UNIT
I _S	Safety input, output, or supply current	R _{θJA} = 212°C/W, V _I = 5.25 V, T _J = 150°C, T _A = 25°C			112	mA
		R _{θJA} = 212°C/W, V _I = 3.45 V, T _J = 150°C, T _A = 25°C			171	
T _S	Maximum safety temperature				150	°C

The safety-limiting constraint is the absolute-maximum junction temperature specified in the [Absolute Maximum Ratings](#) table. The power dissipation and junction-to-air thermal impedance of the device installed in the application hardware determines the junction temperature. The assumed junction-to-air thermal resistance in the [Thermal Information](#) table is that of a device installed in the JESD51-3, Low-Effective-Thermal-Conductivity Test Board for Leaded Surface-Mount Packages and is conservative. The power is the recommended maximum input voltage times the current. The junction temperature is then the ambient temperature plus the power times the junction-to-air thermal resistance.

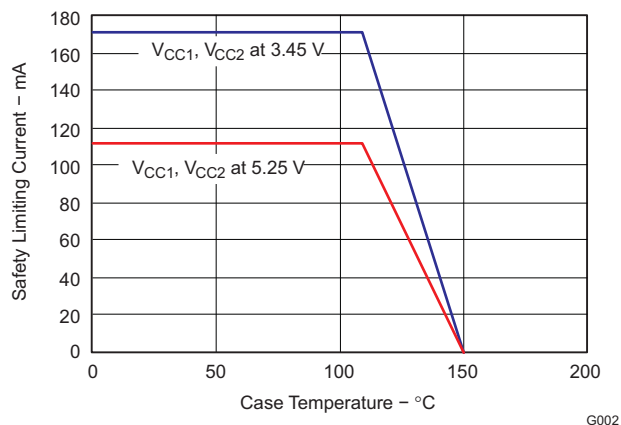

Figure 10. R_{θJC} Thermal Derating Curve per VDE

8.3.4 Regulatory Information

VDE	CSA	UL	CQC
Certified according to DIN V VDE V 0884-10 (VDE V 0884-10):2006-12 and DIN EN 61010-1 (VDE 0411-1): 2011-07	Approved under CSA Component Acceptance Notice #5A	Recognized under UL1577 Component Recognition Program ⁽¹⁾	Certified according to GB4943.1-2011
Basic Insulation Maximum Transient Overvoltage, 4242 V _{PK} Maximum Working Voltage, 566 V _{PK}	Basic insulation per CSA 60950-1-07 and IEC 60950-1 (2nd Ed), 390 VRMS maximum working voltage	Single Protection, 2500 V _{RMS}	Basic Insulation, Altitude ≤ 5000 m, Tropical Climate, 250 V _{RMS} maximum working voltage
Certificate number: 40016131	Master contract number: 220991	File number: E181974	Certificate number: CQC14001109540

(1) Production tested ≥ 3000 V_{RMS} for 1 second in accordance with UL 1577.

8.4 Device Functional Modes

Table 2 shows the device functions.

Table 2. Function Table⁽¹⁾

VCCI	VCCO	INPUT INA, INB	OUTPUT OUTA, OUTB
PU	PU	H	H
		L	L
		Open	H ⁽²⁾
PD	PU	X	H ⁽²⁾
X	PD	X	Undetermined

- (1) V_{CCI} = Input-side power supply; V_{CDO} = Output-side power supply; PU = Powered up (V_{CC} ≥ 3.15 V); PD = Powered down (V_{CC} ≤ 2.1 V); X = Irrelevant; H = High level; L = Low level
 (2) In fail-safe condition, output defaults to high level.

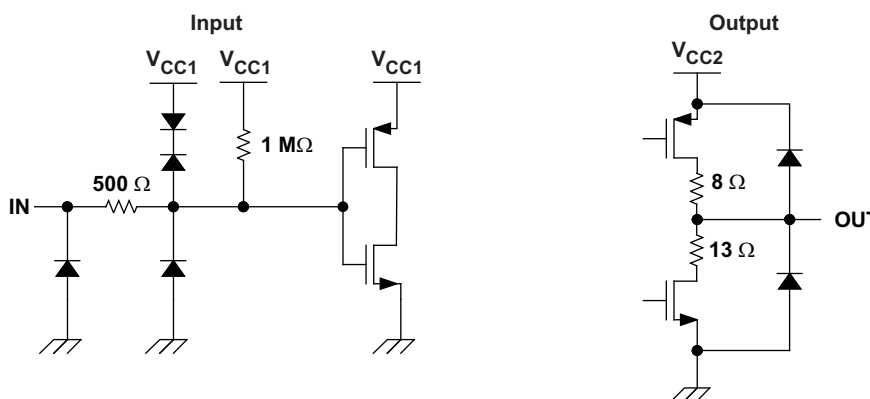

Figure 11. Device I/O Schematics

9 Application and Implementation

NOTE

Information in the following applications sections is not part of the TI component specification, and TI does not warrant its accuracy or completeness. TI's customers are responsible for determining suitability of components for their purposes. Customers should validate and test their design implementation to confirm system functionality.

9.1 Application Information

The ISO7421-EP device uses a single-ended TTL-logic switching technology. Its supply voltage range is from 3.15 V to 5.25 V for both supplies, V_{CC1} and V_{CC2} . When designing with digital isolators, it is important to keep in mind that due to the single-ended design structure, digital isolators do not conform to any specific interface standard and are only intended for isolating single-ended CMOS or TTL digital signal lines. The isolator is typically placed between the data controller (that is, μ C or UART), and a data converter or a line transceiver, regardless of the interface type or standard.

9.2 Typical Application

ISO7421-EP can be used with Texas Instruments' mixed signal micro-controller, digital-to-analog converter, transformer driver, and voltage regulator to create an isolated 4-20 mA current loop.

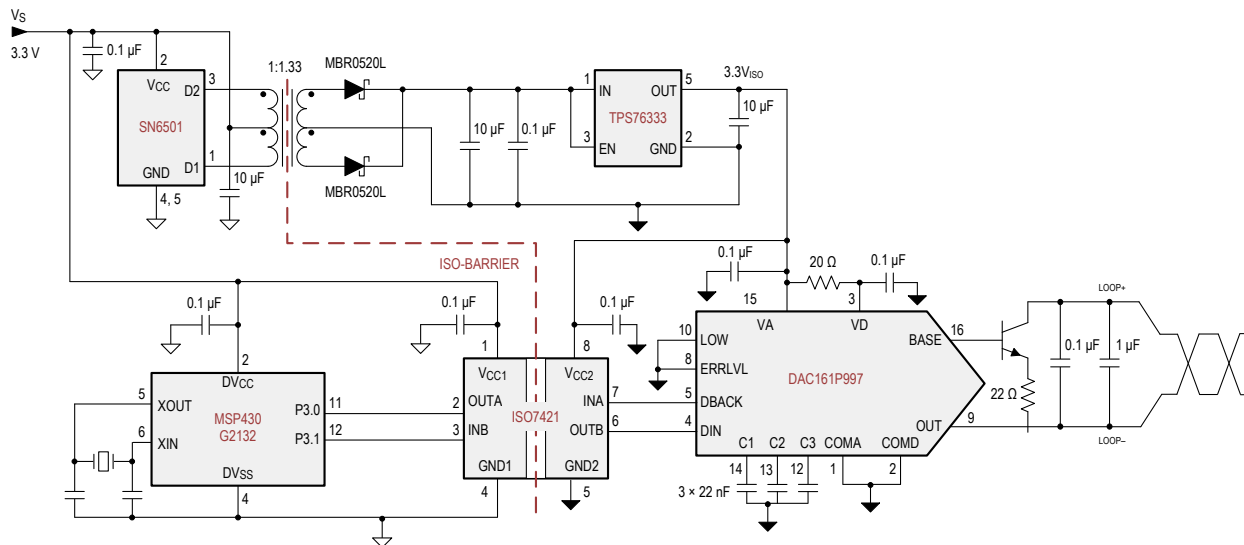

Figure 12. Isolated 4- to 20-mA Current Loop

9.2.1 Design Requirements

For applications that require isolation in place of using x-fmr to provide isolation, ISO7421-EP meets the system needs with small size. Unlike optocouplers, which require external components to improve performance, provide bias, or limit current, the ISO7421-EP device only requires two external bypass capacitors to operate.

Typical Application (continued)

9.2.2 Detailed Design Procedure

ISO7421 digital isolator containing two channels has logic input and output buffer isolated by silicon dioxide (SiO₂) isolation barrier. When using ISO7421 in conjunction with isolated power supplies, these devices prevent noise currents on a data bus or other circuit from entering the local ground and interfering with or damaging sensitive circuitry. ISO7421 are specified for signaling rate up to 1Mbps. These devices also transmit data with much shorter pulse widths, in most cases, because of their fast response time. Designer must add external filtering to remove spurious signals with input pulse duration < 20 ns.

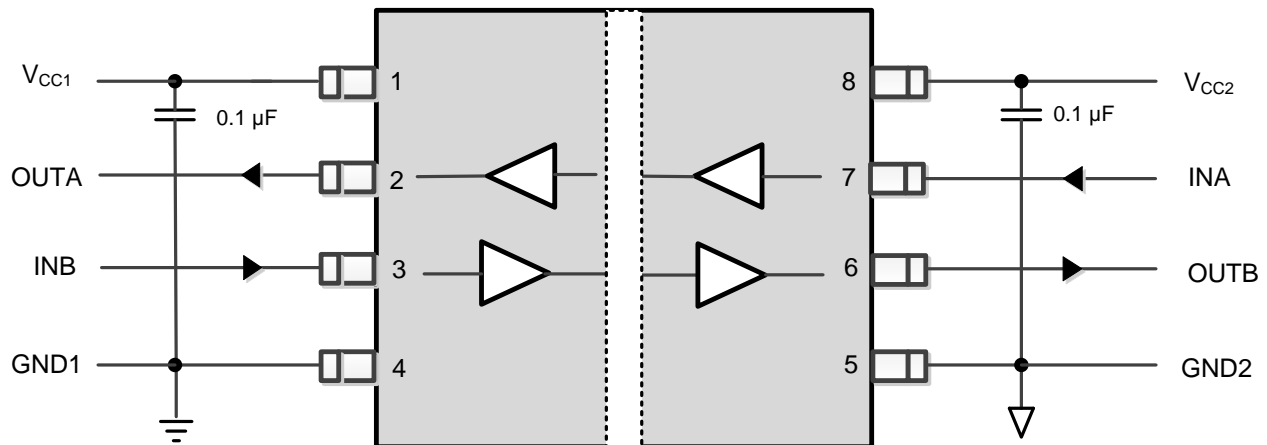

Figure 13. Typical ISO7421-EP Circuit Hookup

9.2.3 Application Curve

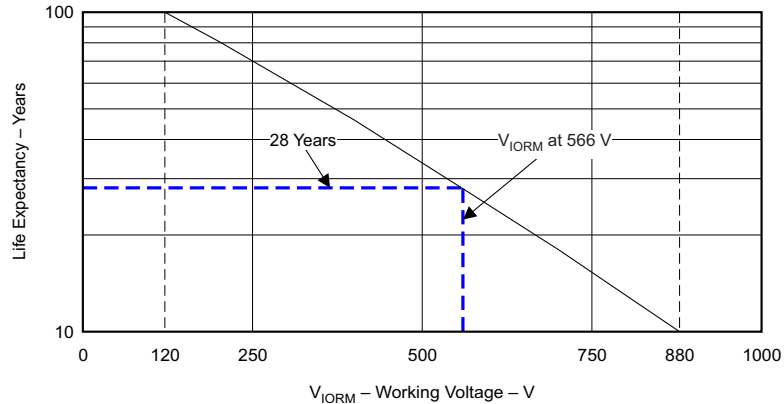

Figure 14. Life Expectancy vs Working Voltage

G001

10 Power Supply Recommendations

Install high quality X7R capacitors typically 0.1 μF close to the device. To ensure reliable operation at all data rates and supply voltages, a 0.1 μF bypass capacitor is recommended at input and output supply pins (V_{CC1} and V_{CC2}). The capacitors should be placed as close to the supply pins as possible. If only a single primary-side power supply is available in an application, isolated power can be generated for the secondary-side with the help of a transformer driver such as Texas Instruments' [SN6501](#). For such applications, detailed power supply design and transformer selection recommendations are available in SN6501 datasheet ([SLLSEA0](#)).

11 Layout

11.1 Layout Guidelines

There are several signals that conduct fast charging current or voltages that can interact with stray inductance or parasitic capacitors to generate noise. Thus to eliminate these problems V_{in} ins of ISO7421 should be bypass to gnd with low esr ceramic bypass capacitor with X7R dielectric. A minimum of four layers is required to accomplish a low EMI PCB design (see [Figure 15](#)). Layer stacking should be in the following order (top-to-bottom): high-speed signal layer, ground plane, power plane and low-frequency signal layer.

- Routing the high-speed traces on the top layer avoids the use of vias (and the introduction of their inductances) and allows for clean interconnects between the isolator and the transmitter and receiver circuits of the data link.
- Placing a solid ground plane next to the high-speed signal layer establishes controlled impedance for transmission line interconnects and provides an excellent low-inductance path for the return current flow.
- Placing the power plane next to the ground plane creates additional high-frequency bypass capacitance of approximately 100pF/in².
- Routing the slower speed control signals on the bottom layer allows for greater flexibility as these signal links usually have margin to tolerate discontinuities such as vias.

If an additional supply voltage plane or signal layer is needed, add a second power / ground plane system to the stack to keep it symmetrical. This makes the stack mechanically stable and prevents it from warping. Also the power and ground plane of each power system can be placed closer together, thus increasing the high-frequency bypass capacitance significantly.

For detailed layout recommendations, see Application Note *Digital Isolator Design Guide*, [SLLA284](#).

11.1.1 PCB Material

For digital circuit boards operating below 150 Mbps, (or rise and fall times higher than 1 ns), and trace lengths of up to 10 inches, use standard FR-4 epoxy-glass as PCB material. FR-4 (Flame Retardant 4) meets the requirements of Underwriters Laboratories UL94-V0, and is preferred over cheaper alternatives due to its lower dielectric losses at high frequencies, less moisture absorption, greater strength and stiffness, and its self-extinguishing flammability-characteristics.

11.2 Layout Example

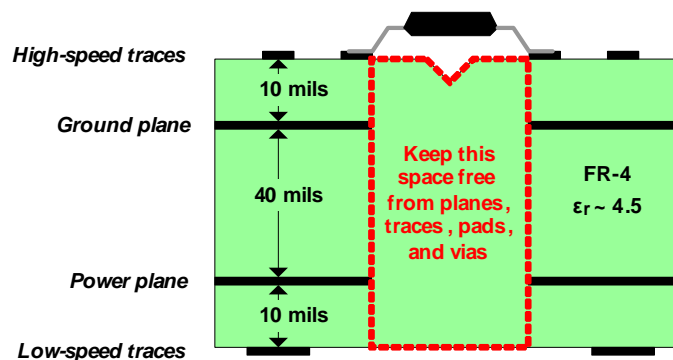

Figure 15. Recommended Layer Stack

12 器件和文档支持

12.1 文档支持

12.1.1 相关文档

相关文档如下:

- 《SN6501 用于隔离电源的变压器驱动器》， [SLLSEA0](#)
- 《隔离相关术语》， [SLLA353](#)
- 《数字隔离器设计指南》， [SLLA284](#)

12.2 社区资源

The following links connect to TI community resources. Linked contents are provided "AS IS" by the respective contributors. They do not constitute TI specifications and do not necessarily reflect TI's views; see TI's [Terms of Use](#).

TI E2E™ Online Community *TI's Engineer-to-Engineer (E2E) Community*. Created to foster collaboration among engineers. At e2e.ti.com, you can ask questions, share knowledge, explore ideas and help solve problems with fellow engineers.

Design Support *TI's Design Support* Quickly find helpful E2E forums along with design support tools and contact information for technical support.

12.3 商标

DeviceNet, E2E are trademarks of Texas Instruments.
All other trademarks are the property of their respective owners.

12.4 静电放电警告



这些装置包含有限的内置 ESD 保护。存储或装卸时，应将导线一起截短或将装置放置于导电泡棉中，以防止 MOS 门极遭受静电损伤。

12.5 Glossary

[SLYZ022](#) — *TI Glossary*.

This glossary lists and explains terms, acronyms, and definitions.

13 机械、封装和可订购信息

以下页中包括机械、封装和可订购信息。这些信息是针对指定器件可提供的最新数据。这些数据会在无通知且不对本文档进行修订的情况下发生改变。欲获得该数据表的浏览器版本，请查阅左侧的导航栏。

PACKAGING INFORMATION

Orderable part number	Status (1)	Material type (2)	Package Pins	Package qty Carrier	RoHS (3)	Lead finish/ Ball material (4)	MSL rating/ Peak reflow (5)	Op temp (°C)	Part marking (6)
ISO7421MDREP	Active	Production	SOIC (D) 8	2500 LARGE T&R	Yes	NIPDAU	Level-1-260C-UNLIM	-55 to 125	7421EP
ISO7421MDREP.A	Active	Production	SOIC (D) 8	2500 LARGE T&R	Yes	NIPDAU	Level-1-260C-UNLIM	-55 to 125	7421EP
V62/16605-01XE	Active	Production	SOIC (D) 8	2500 LARGE T&R	Yes	NIPDAU	Level-1-260C-UNLIM	-55 to 125	7421EP

(1) **Status:** For more details on status, see our [product life cycle](#).

(2) **Material type:** When designated, preproduction parts are prototypes/experimental devices, and are not yet approved or released for full production. Testing and final process, including without limitation quality assurance, reliability performance testing, and/or process qualification, may not yet be complete, and this item is subject to further changes or possible discontinuation. If available for ordering, purchases will be subject to an additional waiver at checkout, and are intended for early internal evaluation purposes only. These items are sold without warranties of any kind.

(3) **RoHS values:** Yes, No, RoHS Exempt. See the [TI RoHS Statement](#) for additional information and value definition.

(4) **Lead finish/Ball material:** Parts may have multiple material finish options. Finish options are separated by a vertical ruled line. Lead finish/Ball material values may wrap to two lines if the finish value exceeds the maximum column width.

(5) **MSL rating/Peak reflow:** The moisture sensitivity level ratings and peak solder (reflow) temperatures. In the event that a part has multiple moisture sensitivity ratings, only the lowest level per JEDEC standards is shown. Refer to the shipping label for the actual reflow temperature that will be used to mount the part to the printed circuit board.

(6) **Part marking:** There may be an additional marking, which relates to the logo, the lot trace code information, or the environmental category of the part.

Multiple part markings will be inside parentheses. Only one part marking contained in parentheses and separated by a "-" will appear on a part. If a line is indented then it is a continuation of the previous line and the two combined represent the entire part marking for that device.

Important Information and Disclaimer: The information provided on this page represents TI's knowledge and belief as of the date that it is provided. TI bases its knowledge and belief on information provided by third parties, and makes no representation or warranty as to the accuracy of such information. Efforts are underway to better integrate information from third parties. TI has taken and continues to take reasonable steps to provide representative and accurate information but may not have conducted destructive testing or chemical analysis on incoming materials and chemicals. TI and TI suppliers consider certain information to be proprietary, and thus CAS numbers and other limited information may not be available for release.

In no event shall TI's liability arising out of such information exceed the total purchase price of the TI part(s) at issue in this document sold by TI to Customer on an annual basis.

OTHER QUALIFIED VERSIONS OF ISO7421-EP :

- Catalog : [ISO7421](#)

NOTE: Qualified Version Definitions:

- Catalog - TI's standard catalog product



D0008A

PACKAGE OUTLINE

SOIC - 1.75 mm max height

SMALL OUTLINE INTEGRATED CIRCUIT



4214825/C 02/2019

NOTES:

1. Linear dimensions are in inches [millimeters]. Dimensions in parenthesis are for reference only. Controlling dimensions are in inches. Dimensioning and tolerancing per ASME Y14.5M.
2. This drawing is subject to change without notice.
3. This dimension does not include mold flash, protrusions, or gate burrs. Mold flash, protrusions, or gate burrs shall not exceed $.006$ [0.15] per side.
4. This dimension does not include interlead flash.
5. Reference JEDEC registration MS-012, variation AA.

EXAMPLE BOARD LAYOUT

D0008A

SOIC - 1.75 mm max height

SMALL OUTLINE INTEGRATED CIRCUIT



LAND PATTERN EXAMPLE
 EXPOSED METAL SHOWN
 SCALE:8X



SOLDER MASK DETAILS

4214825/C 02/2019

NOTES: (continued)

- 6. Publication IPC-7351 may have alternate designs.
- 7. Solder mask tolerances between and around signal pads can vary based on board fabrication site.

EXAMPLE STENCIL DESIGN

D0008A

SOIC - 1.75 mm max height

SMALL OUTLINE INTEGRATED CIRCUIT



SOLDER PASTE EXAMPLE
BASED ON .005 INCH [0.125 MM] THICK STENCIL
SCALE:8X

4214825/C 02/2019

NOTES: (continued)

8. Laser cutting apertures with trapezoidal walls and rounded corners may offer better paste release. IPC-7525 may have alternate design recommendations.
9. Board assembly site may have different recommendations for stencil design.

重要通知和免责声明

TI“按原样”提供技术和可靠性数据（包括数据表）、设计资源（包括参考设计）、应用或其他设计建议、网络工具、安全信息和其他资源，不保证没有瑕疵且不做任何明示或暗示的担保，包括但不限于对适销性、某特定用途方面的适用性或不侵犯任何第三方知识产权的暗示担保。

这些资源可供使用 TI 产品进行设计的熟练开发人员使用。您将自行承担以下全部责任：(1) 针对您的应用选择合适的 TI 产品，(2) 设计、验证并测试您的应用，(3) 确保您的应用满足相应标准以及任何其他功能安全、信息安全、监管或其他要求。

这些资源如有变更，恕不另行通知。TI 授权您仅可将这些资源用于研发本资源所述的 TI 产品的相关应用。严禁以其他方式对这些资源进行复制或展示。您无权使用任何其他 TI 知识产权或任何第三方知识产权。您应全额赔偿因在这些资源的使用中对 TI 及其代表造成的任何索赔、损害、成本、损失和债务，TI 对此概不负责。

TI 提供的产品受 [TI 的销售条款](#) 或 [ti.com](#) 上其他适用条款/TI 产品随附的其他适用条款的约束。TI 提供这些资源并不会扩展或以其他方式更改 TI 针对 TI 产品发布的适用的担保或担保免责声明。

TI 反对并拒绝您可能提出的任何其他或不同的条款。

邮寄地址：Texas Instruments, Post Office Box 655303, Dallas, Texas 75265
版权所有 © 2025，德州仪器 (TI) 公司