

ISO5851-Q1 具有有源安全特性的高 CMTI 2.5A/5A 隔离式 IGBT、MOSFET 栅极驱动器

1 特性

- 适用于汽车电子 标准
- 具有符合 AEC-Q100 标准的下列结果:
 - 器件温度 1 级: -40°C 至 125°C 的环境运行温度范围
 - 器件人体模型 (HBM) 分类等级 3A
 - 器件充电器件模型 (CDM) 分类等级 C6
- 在 $V_{\text{CM}} = 1500\text{V}$ 时, 共模瞬态抗扰度 (CMTI) 的最小值为 $100\text{kV}/\mu\text{s}$
- 2.5A 峰值拉电流和 5A 峰值灌电流
- 短暂传播延迟: 76ns (典型值), 110ns (最大值)
- 2A 有源米勒钳位
- 输出短路钳位
- 在检测到去饱和和故障时通过 $\overline{\text{FLT}}$ 发出故障报警, 并通过 $\overline{\text{RST}}$ 复位
- 具有就绪 (RDY) 引脚指示的输入和输出欠压锁定 (UVLO)
- 有源输出下拉特性, 在低电源或输入悬空的情况下默认输出低电平
- 3V 至 5.5V 输入电源电压
- 15V 至 30V 输出驱动器电源电压
- 互补金属氧化物半导体 (CMOS) 兼容输入
- 抑制短于 20ns 的输入脉冲和瞬态噪声
- 可承受的浪涌隔离电压达 $12800\text{V}_{\text{PK}}$
- 安全及管理认证:
 - 符合 DIN V VDE V 0884-10 (VDE V 0884-10):2006-12 标准的 $8000\text{V}_{\text{PK}}\text{V}_{\text{IOTM}}$ 和 $2121\text{V}_{\text{PK}}\text{V}_{\text{IORM}}$ 增强型隔离
 - 符合 UL 1577 标准且长达 1 分钟的 $5700\text{V}_{\text{RMS}}$ 隔离
 - CSA 组件验收通知 5A、IEC 60950-1 和 IEC 60601-1 终端设备标准
 - 符合 EN 61010-1 和 EN 60950-1 标准的 TUV 认证
 - GB4943.1-2011 CQC 认证
 - 已通过 UL、VDE、CQC、TUV 认证并规划进行 CSA 认证

2 应用

- 隔离式绝缘栅双极型晶体管 (IGBT) 和金属氧化物半导体场效应晶体管 (MOSFET) 驱动器:
 - 混合动力汽车 (HEV) 和电动车 (EV) 电源模块
 - 工业电机控制驱动
 - 工业电源
 - 太阳能逆变器
 - 感应加热

3 说明

ISO5851-Q1 是一款用于 IGBT 和 MOSFET 的 5.7 kV_{RMS} 增强型隔离栅极驱动器, 具有 2.5A 的拉电流能力和 5A 的灌电流能力。输入端由 3V 至 5.5V 的单电源供电运行。输出端允许的电源范围为 15V 至 30V。两个互补 CMOS 输入控制栅极驱动器的输出状态。76ns 的短暂传播时间保证了对于输出级的精确控制。

内置的去饱和 (DESAT) 故障检测功能可识别 IGBT 何时处于过载状态。当检测到 DESAT 时, 栅极驱动器输出会被拉低至 V_{EE2} 电势, 从而将 IGBT 立即关断。

当发生去饱和和故障时, 器件会通过隔离栅发送故障信号, 以将输入端的 $\overline{\text{FLT}}$ 输出拉为低电平并阻断隔离器的输入。 $\overline{\text{FLT}}$ 的输出状态将被锁存, 可通过 $\overline{\text{RST}}$ 输入上的低电平有效脉冲复位。

器件信息⁽¹⁾

器件型号	封装	封装尺寸 (标称值)
ISO5851-Q1	SOIC (16)	10.30mm x 7.50mm

(1) 如需了解所有可用封装, 请见数据表末尾的可订购产品附录。

功能方框图

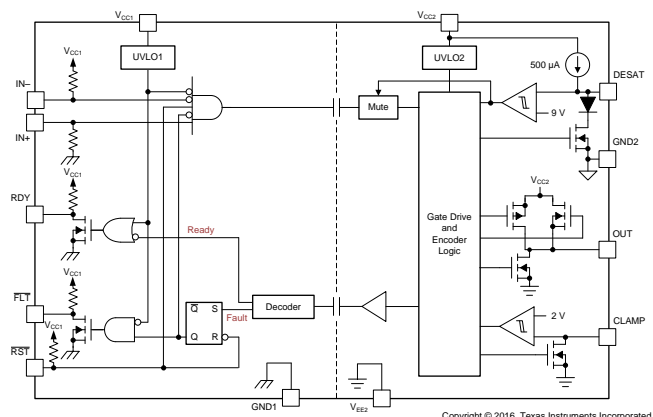

目录

1	特性	1	9	Detailed Description	19
2	应用	1	9.1	Overview	19
3	说明	1	9.2	Functional Block Diagram	19
4	修订历史	2	9.3	Feature Description	20
5	说明 (续)	3	9.4	Device Functional Modes	21
6	Pin Configuration and Function	4	10	Application and Implementation	22
7	Specifications	5	10.1	Application Information	22
7.1	Absolute Maximum Ratings	5	10.2	Typical Applications	22
7.2	ESD Ratings	5	11	Power Supply Recommendations	31
7.3	Recommended Operating Conditions	5	12	Layout	31
7.4	Thermal Information	5	12.1	Layout Guidelines	31
7.5	Power Rating	6	12.2	PCB Material	31
7.6	Insulation Characteristics	6	12.3	Layout Example	31
7.7	Safety Limiting Values	7	13	器件和文档支持	32
7.8	Safety-Related Certifications	7	13.1	文档支持	32
7.9	Electrical Characteristics	8	13.2	接收文档更新通知	32
7.10	Switching Characteristics	9	13.3	社区资源	32
7.11	Safety and Insulation Characteristics Curves	10	13.4	商标	32
7.12	Typical Characteristics	11	13.5	静电放电警告	32
8	Parameter Measurement Information	17	13.6	Glossary	32
			14	机械、封装和可订购信息	33

4 修订历史

注：之前版本的页码可能与当前版本有所不同。

日期	修订版本	注释
2015 年 9 月	*	最初发布版本

5 说明（续）

如果在由双极输出电源供电的正常运行期间关断 IGBT，输出电压会被硬钳位为 V_{EE2} 。如果输出电源为单极，那么可采用有源米勒钳位，这种钳位会在一条低阻抗路径上灌入米勒电流，从而防止 IGBT 在高电压瞬态条件下发生动态导通。

当发生去饱和故障时，器件会通过隔离栅发送故障信号，以将输入端的 \overline{FLT} 输出拉为低电平并阻断隔离器的输入。 \overline{FLT} 的输出状态将被锁存，可通过 \overline{RST} 输入上的低电平有效脉冲复位。

如果在由双极输出电源供电的正常运行期间关断 IGBT，输出电压会被硬钳位为 V_{EE2} 。如果输出电源为单极，那么可采用有源米勒钳位，这种钳位会在一条低阻抗路径上灌入米勒电流，从而防止 IGBT 在高电压瞬态条件下发生动态导通。

栅极驱动器是否准备就绪待运行由两个欠压锁定电路控制，这两个电路会监视输入端和输出端的电源。如果任意一端电源不足，RDY 输出会变为低电平；否则，该输出为高电平。

ISO5851-Q1 采用 16 引脚小外形尺寸集成电路 (SOIC) 封装。此器件的额定工作环境温度范围为 -40°C 至 125°C 。

6 Pin Configuration and Function

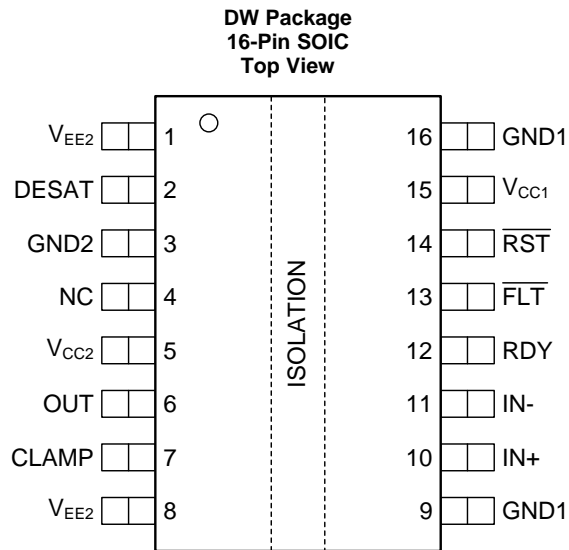

Pin Functions

PIN		I/O	DESCRIPTION
NAME	NO.		
V_{EE2}	1, 8	-	Output negative supply. Connect to GND2 for Unipolar supply application.
DESAT	2	I	Desaturation voltage input
GND2	3	-	Gate drive common. Connect to IGBT emitter.
NC	4	-	Not connected
V_{CC2}	5	-	Most positive output supply potential.
OUT	6	O	Gate drive voltage output
CLAMP	7	O	Miller clamp output
GND1	9, 16	-	Input ground
IN+	10	I	Non-inverting gate drive voltage control input
IN-	11	I	Inverting gate drive voltage control input
RDY	12	O	Power-good output, active high when both supplies are good.
$\overline{\text{FLT}}$	13	O	Fault output, low-active during DESAT condition
$\overline{\text{RST}}$	14	I	Reset input, apply a low pulse to reset fault latch.
V_{CC1}	15	-	Positive input supply (3 V to 5.5 V)

7 Specifications

7.1 Absolute Maximum Ratings⁽¹⁾

Over operating free-air temperature range (unless otherwise noted)

		MIN	MAX	UNIT	
V _{CC1}	Supply voltage input side	GND1 - 0.3	6	V	
V _{CC2}	Positive supply voltage output side	(V _{CC2} - GND2)	-0.3	35	V
V _{EE2}	Negative supply voltage output side	(V _{EE2} - GND2)	-17.5	0.3	V
V _(SUP2)	Total supply output voltage	(V _{CC2} - V _{EE2})	-0.3	35	V
V _{OUT}	Gate driver output voltage	V _{EE2} - 0.3	V _{CC2} + 0.3	V	
I _(OUTH)	Gate driver high output current	Gate driver high output current (max pulse width = 10 μs, max duty cycle = 0.2%)		2.7	A
I _(OUTL)	Gate driver low output current			5.5	A
V _(LIP)	Voltage at IN+, IN-, $\overline{\text{FLT}}$, RDY, $\overline{\text{RST}}$	GND1 - 0.3	V _{CC1} + 0.3	V	
I _(LOP)	Output current of $\overline{\text{FLT}}$, RDY			10	mA
V _(DESAT)	Voltage at DESAT	GND2 - 0.3	V _{CC2} + 0.3	V	
V _(CLAMP)	Clamp voltage	V _{EE2} - 0.3	V _{CC2} + 0.3	V	
T _J	Junction temperature	-40	150	°C	
T _{STG}	Storage temperature	-65	150	°C	

- (1) Stresses beyond those listed under absolute maximum ratings may cause permanent damage to the device. These are stress ratings only and functional operation of the device at these or any conditions beyond those indicated under recommended operating conditions is not implied. Exposure to absolute-maximum-rated conditions for extended periods may affect device reliability

7.2 ESD Ratings

		VALUE	UNIT
V _(ESD)	Electrostatic discharge	Human-body model (HBM), per AEC Q100-002 ⁽¹⁾	±4000
		Charged-device model (CDM), per AEC Q100-011	±1500

- (1) AEC Q100-002 indicates that HBM stressing shall be in accordance with the ANSI/ESDA/JEDEC JS-001 specification.

7.3 Recommended Operating Conditions

over operating free-air temperature range (unless otherwise noted)

		MIN	NOM	MAX	UNIT
V _{CC1}	Supply voltage input side	3		5.5	V
V _{CC2}	Positive supply voltage output side (V _{CC2} - GND2)	15		30	V
V _{EE2}	Negative supply voltage output side (V _{EE2} - GND2)	-15		0	V
V _(SUP2)	Total supply voltage output side (V _{CC2} - V _{EE2})	15		30	V
V _{IH}	High-level input voltage (IN+, IN-, $\overline{\text{RST}}$)	0.7 x V _{CC1}		V _{CC1}	V
V _{IL}	Low-level input voltage (IN+, IN-, $\overline{\text{RST}}$)	0		0.3 x V _{CC1}	V
t _{UI}	Pulse width at IN+, IN- for full output (C _{LOAD} = 1nF)	40			ns
t _{RST}	Pulse width at $\overline{\text{RST}}$ for resetting fault latch	800			ns
T _A	Ambient temperature	-40	25	125	°C

7.4 Thermal Information

THERMAL METRIC ⁽¹⁾		DW (SOIC)	UNIT
		16 PINS	
θ _{JA}	Junction-to-ambient thermal resistance	99.6	°C/W
θ _{Jtop}	Junction-to-case (top) thermal resistance	48.5	
θ _{JB}	Junction-to-board thermal resistance	56.5	
ψ _{JT}	Junction-to-top characterization parameter	29.2	
ψ _{JB}	Junction-to-board characterization parameter	56.5	

- (1) For more information about traditional and new thermal metrics, see the [Semiconductor and IC Package Thermal Metrics](#) application report.

7.5 Power Rating

		VALUE	UNIT
P_D	Maximum power dissipation ⁽¹⁾	1255	mW
P_{ID}	Maximum input power dissipation	175	
P_{OD}	Maximum output power dissipation	1080	

- (1) Full chip power dissipation is de-rated 10.04 mW/°C beyond 25°C ambient temperature. At 125°C ambient temperature, a maximum of 251 mW total power dissipation is allowed. Power dissipation can be optimized depending on ambient temperature and board design, while ensuring that Junction temperature does not exceed 150°C.

7.6 Insulation Characteristics

PARAMETER	TEST CONDITIONS	SPECIFICATION	UNIT
CLR External clearance ⁽¹⁾	Shortest terminal-to-terminal distance through air	8	mm
CPG External creepage ⁽¹⁾	Shortest terminal-to-terminal distance across the package surface	8	mm
DTI Distance through the insulation	Minimum internal gap (internal clearance)	21	μm
CTI Comparative tracking index	DIN EN 60112 (VDE 0303-11); IEC 60112	>600	V
Material group	According to IEC 60664-1	I	
Overvoltage category per IEC 60664-1	Rated mains voltage ≤ 600 V _{RMS}	I-IV	
	Rated mains voltage ≤ 1000 V _{RMS}	I-III	
DIN V VDE V 0884-10 (VDE V 0884-10):2006-12⁽²⁾			
V_{IORM} Maximum repetitive peak isolation voltage	AC voltage (bipolar)	2121	V _{PK}
V_{IOWM} Maximum isolation working voltage	AC voltage, Time dependent dielectric breakdown (TDDB) Test, see Figure 1	1500	V _{RMS}
	DC voltage	2121	V _{DC}
V_{IOTM} Maximum Transient isolation voltage	$V_{TEST} = V_{IOTM}$, t = 60 sec (qualification), t = 1 sec (100% production)	8000	V _{PK}
V_{IOSM} Maximum surge isolation voltage ⁽³⁾	Test method per IEC 60065, 1.2/50 μs waveform, $V_{TEST} = 1.6 \times V_{IOSM} = 12800 V_{PK}$ (qualification)	8000	
q_{pd} Apparent charge ⁽⁴⁾	Method a: After I/O safety test subgroup 2/3, $V_{ini} = V_{IOTM}$, $t_{ini} = 60$ s; $V_{pd(m)} = 1.2 \times V_{IORM} = 2545 V_{PK}$, $t_m = 10$ s	≤5	pC
	Method a: After environmental tests subgroup 1, $V_{ini} = V_{IOTM}$, $t_{ini} = 60$ s; $V_{pd(m)} = 1.6 \times V_{IORM} = 3394 V_{PK}$, $t_m = 10$ s	≤5	
	Method b1: At routine test (100% production) and preconditioning (type test) $V_{ini} = V_{IOTM}$, $t_{ini} = 60$ s; $V_{pd(m)} = 1.875 \times V_{IORM} = 3977 V_{PK}$, $t_m = 10$ s	≤5	
R_{IO} Isolation resistance, input to output ⁽⁵⁾	$V_{IO} = 500$ V at T _S	> 10 ⁹	Ω
	$V_{IO} = 500$ V, T _A = 25°C	>10 ¹²	Ω
	$V_{IO} = 500$ V, 100°C ≤ T _A ≤ 125°C	>10 ¹¹	Ω
C_{IO} Barrier capacitance, input to output ⁽⁵⁾	$V_{IO} = 0.4 \times \sin(2\pi ft)$, f = 1 MHz	1	pF
Pollution degree		2	
UL 1577			
V_{ISO} Withstanding Isolation voltage	$V_{TEST} = V_{ISO}$, t = 60 sec (qualification), $V_{TEST} = 1.2 \times V_{ISO} = 6840 V_{RMS}$, t = 1 sec (100% production)	5700	V _{RMS}

- (1) Creepage and clearance requirements should be applied according to the specific equipment isolation standards of an application. Care should be taken to maintain the creepage and clearance distance of a board design to ensure that the mounting pads of the isolator on the printed-circuit board do not reduce this distance. Creepage and clearance on a printed-circuit board become equal in certain cases. Techniques such as inserting grooves and/or ribs on a printed circuit board are used to help increase these specifications.
- (2) This coupler is suitable for safe electrical insulation only within the safety ratings. Compliance with the safety ratings shall be ensured by means of suitable protective circuits.
- (3) Testing is carried out in air or oil to determine the intrinsic surge immunity of the isolation barrier.
- (4) Apparent charge is electrical discharge caused by a partial discharge (pd).
- (5) All pins on each side of the barrier tied together creating a two-terminal device.

7.7 Safety Limiting Values

Safety limiting intends to prevent potential damage to the isolation barrier upon failure of input or output circuitry. A failure of the I/O can allow low resistance to ground or the supply and, without current limiting, dissipate sufficient power to overheat the die and damage the isolation barrier, potentially leading to secondary system failures.

PARAMETER		TEST CONDITIONS	MIN	TYP	MAX	UNIT
I _S	Safety input, output or supply current	$\theta_{JA} = 99.6^{\circ}\text{C/W}$, $V_I = 3.6\text{ V}$, $T_J = 150^{\circ}\text{C}$, $T_A = 25^{\circ}\text{C}$			349	mA
		$\theta_{JA} = 99.6^{\circ}\text{C/W}$, $V_I = 5.5\text{ V}$, $T_J = 150^{\circ}\text{C}$, $T_A = 25^{\circ}\text{C}$			228	
		$\theta_{JA} = 99.6^{\circ}\text{C/W}$, $V_I = 15\text{ V}$, $T_J = 150^{\circ}\text{C}$, $T_A = 25^{\circ}\text{C}$			84	
		$\theta_{JA} = 99.6^{\circ}\text{C/W}$, $V_I = 30\text{ V}$, $T_J = 150^{\circ}\text{C}$, $T_A = 25^{\circ}\text{C}$			42	
P _S	Safety input, output, or total power	$\theta_{JA} = 99.6^{\circ}\text{C/W}$, $T_J = 150^{\circ}\text{C}$, $T_A = 25^{\circ}\text{C}$			1255 ⁽¹⁾	
T _S	Maximum ambient safety temperature				150	°C

(1) Input, output, or the sum of input and output power should not exceed this value

7.8 Safety-Related Certifications

VDE	CSA	UL	CQC	TUV
Certified according to DIN V VDE V 0884-10 (VDE V 0884-10):2006-12 and DIN EN 60950-1 (VDE 0805 Teil 1):2011-01	Plan to certify under CSA Component Acceptance Notice 5A, IEC 60950-1, and IEC 60601-1	Certified according to UL 1577 Component Recognition Program	Certified according to GB 4943.1-2011	Certified according to EN 61010-1:2010 (3rd Ed) and EN 60950-1:2006/A11:2009/A1:2010/A12:2011/A2:2013
Reinforced Insulation Maximum Transient isolation voltage, 8000 V _{PK} ; Maximum surge isolation voltage, 8000 V _{PK} ; Maximum repetitive peak isolation voltage, 2121 V _{PK}	Isolation Rating of 5700 V _{RMS} ; Reinforced insulation per CSA 60950-1- 07+A1+A2 and IEC 60950-1 (2nd Ed.), 800 V _{RMS} max working voltage (pollution degree 2, material group I) ; 2 MOPP (Means of Patient Protection) per CSA 60601-1:14 and IEC 60601-1 Ed. 3.1, 250 V _{RMS} (354 V _{PK}) max working voltage	Single Protection, 5700 V _{RMS} (1)	Reinforced Insulation, Altitude ≤ 5000m, Tropical climate, 400 V _{RMS} maximum working voltage	5700 V _{RMS} Reinforced insulation per EN 61010-1:2010 (3rd Ed) up to working voltage of 600 V _{RMS} 5700 V _{RMS} Reinforced insulation per EN 60950-1:2006/A11:2009/A1:2010/A12:2011/A2:2013 up to working voltage of 800 V _{RMS}
Certification completed Certificate number: 40040142	Certification planned	Certification completed File number: E181974	Certification completed Certificate number: CQC16001141761	Certification completed Client ID number: 77311

(1) Production tested ≥6840 V_{RMS} for 1 second in accordance with UL 1577.

The safety-limiting constraint is the absolute-maximum junction temperature specified in the [Absolute Maximum Ratings](#) table. The power dissipation and junction-to-air thermal impedance of the device installed in the application hardware determines the junction temperature. The assumed junction-to-air thermal resistance in the [Thermal Information](#) table is that of a device installed in the High-K Test Board for Leaded Surface-Mount Packages. The power is the recommended maximum input voltage times the current. The junction temperature is then the ambient temperature plus the power times the junction-to-air thermal resistance.

7.9 Electrical Characteristics

Over recommended operating conditions unless otherwise noted. All typical values are at $T_A = 25^\circ\text{C}$, $V_{CC1} = 5\text{ V}$, $V_{CC2} - \text{GND2} = 15\text{ V}$, $\text{GND2} - V_{EE2} = 8\text{ V}$

PARAMETER		TEST CONDITIONS	MIN	TYP	MAX	UNIT
VOLTAGE SUPPLY						
$V_{IT+}(UVLO1)$	Positive-going UVLO1 threshold voltage input side ($V_{CC1} - \text{GND1}$)				2.25	V
$V_{IT-}(UVLO1)$	Negative-going UVLO1 threshold voltage input side ($V_{CC1} - \text{GND1}$)		1.7			V
$V_{HYS}(UVLO1)$	UVLO1 Hysteresis voltage ($V_{IT+} - V_{IT-}$) input side			0.24		V
$V_{IT+}(UVLO2)$	Positive-going UVLO2 threshold voltage output side ($V_{CC2} - \text{GND2}$)			12	13	V
$V_{IT-}(UVLO2)$	Negative-going UVLO2 threshold voltage output side ($V_{CC2} - \text{GND2}$)		9.5	11		V
$V_{HYS}(UVLO2)$	UVLO2 Hysteresis voltage ($V_{IT+} - V_{IT-}$) output side			1		V
I_{Q1}	Input supply quiescent current			2.8	4.5	mA
I_{Q2}	Output supply quiescent current			3.6	6	mA
LOGIC I/O						
$V_{IT+}(IN,RST)$	Positive-going input threshold voltage ($IN+$, $IN-$, RST)				$0.7 \times V_{CC1}$	V
$V_{IT-}(IN,RST)$	Negative-going input threshold voltage ($IN+$, $IN-$, RST)		$0.3 \times V_{CC1}$			V
$V_{HYS}(IN,RST)$	Input hysteresis voltage ($IN+$, $IN-$, RST)			$0.15 \times V_{CC1}$		V
I_{IH}	High-level input leakage at ($IN+$)	$IN+ = V_{CC1}$		100		μA
I_{IL}	Low-level input leakage at ($IN-$, RST)	$IN- = \text{GND1}$, $RST = \text{GND1}$		-100		μA
I_{PU}	Pull-up current of \overline{FLT} , RDY	$V_{(RDY)} = \text{GND1}$, $V_{(FLT)} = \text{GND1}$		100		μA
V_{OL}	Low-level output voltage at \overline{FLT} , RDY	$I_{(FLT)} = 5\text{ mA}$			0.2	V
GATE DRIVER STAGE						
$V_{(OUTPD)}$	Active output pull-down voltage	$I_{OUT} = 200\text{ mA}$, $V_{CC2} = \text{open}$			2	V
$V_{(OUTH)}$	High-level output voltage	$I_{OUT} = -20\text{ mA}$	$V_{CC2} - 0.5$	$V_{CC2} - 0.24$		V
$V_{(OUTL)}$	Low-level output voltage	$I_{OUT} = 20\text{ mA}$		$V_{EE2} + 13$	$V_{EE2} + 50$	mV
$I_{(OUTH)}$	High-level output peak current	$IN+ = \text{high}$, $IN- = \text{low}$, $V_{OUT} = V_{CC2} - 15\text{ V}$	1.5	2.5		A
$I_{(OUTL)}$	Low-level output peak current	$IN+ = \text{low}$, $IN- = \text{high}$, $V_{OUT} = V_{EE2} + 15\text{ V}$	3.4	5		A
ACTIVE MILLER CLAMP						
$V_{(CLP)}$	Low-level clamp voltage	$I_{(CLP)} = 20\text{ mA}$		$V_{EE2} + 0.015$	$V_{EE2} + 0.08$	V
$I_{(CLP)}$	Low-level clamp current	$V_{(CLAMP)} = V_{EE2} + 2.5\text{ V}$	1.6	2.5		A
$V_{(CLTH)}$	Clamp threshold voltage		1.6	2.1	2.5	V
SHORT CIRCUIT CLAMPING						
$V_{(CLP_OUT)}$	Clamping voltage ($V_{OUT} - V_{CC2}$)	$IN+ = \text{high}$, $IN- = \text{low}$, $t_{CLP} = 10\text{ }\mu\text{s}$, $I_{(OUTH)} = 500\text{ mA}$		0.8	1.3	V
$V_{(CLP_CLAMP)}$	Clamping voltage ($V_{CLP} - V_{CC2}$)	$IN+ = \text{high}$, $IN- = \text{low}$, $t_{CLP} = 10\text{ }\mu\text{s}$, $I_{(CLP)} = 500\text{ mA}$		1.3		V
$V_{(CLP_CLAMP)}$	Clamping voltage at CLAMP	$IN+ = \text{High}$, $IN- = \text{Low}$, $I_{(CLP)} = 20\text{ mA}$		0.7	1.1	V
DESAT PROTECTION						
$I_{(CHG)}$	Blanking capacitor charge current	$V_{(DESAT)} - \text{GND2} = 2\text{ V}$	0.42	0.5	0.58	mA
$I_{(DCHG)}$	Blanking capacitor discharge current	$V_{(DESAT)} - \text{GND2} = 6\text{ V}$	9	14		mA
$V_{(DSTH)}$	DESAT threshold voltage with respect to GND2		8.3	9	9.5	V
$V_{(DSL)}$	DESAT voltage with respect to GND2 , when OUT is driven low		0.4		1	V

7.10 Switching Characteristics

Over recommended operating conditions unless otherwise noted. All typical values are at $T_A = 25^\circ\text{C}$, $V_{CC1} = 5\text{ V}$, $V_{CC2} - \text{GND2} = 15\text{ V}$, $\text{GND2} - V_{EE2} = 8\text{ V}$

PARAMETER		TEST CONDITIONS	MIN	TYP	MAX	UNIT	
t_r	Output signal rise time	$C_{\text{LOAD}} = 1\text{ nF}$, see Figure 38 , Figure 39 , and Figure 40	12	20	35	ns	
t_f	Output signal fall time		12	20	37	ns	
$t_{\text{PLH}}, t_{\text{PHL}}$	Propagation Delay			76	110	ns	
$t_{\text{sk-p}}$	Pulse Skew $ t_{\text{PHL}} - t_{\text{PLH}} $				20	ns	
$t_{\text{sk-pp}}$	Part-to-part skew				30 ⁽¹⁾	ns	
t_{GF}	Glitch filter on IN+ , IN- , $\overline{\text{RST}}$			20	30	40	ns
$t_{\text{DESAT}} (10\%)$	DESAT sense to 10% OUT delay			300	415	500	ns
$t_{\text{DESAT}} (\text{GF})$	DESAT glitch filter delay				330		ns
$t_{\text{DESAT}} (\overline{\text{FLT}})$	DESAT sense to $\overline{\text{FLT}}$ -low delay		see Figure 40		2000	2420	ns
t_{LEB}	Leading edge blanking time		see Figure 38 and Figure 39	330	400	500	ns
$t_{\text{GF}}(\text{RSTFLT})$	Glitch filter on $\overline{\text{RST}}$ for resetting $\overline{\text{FLT}}$		300		800	ns	
C_i	Input capacitance ⁽²⁾	$V_i = V_{CC1} / 2 + 0.4 \times \sin(2\pi ft)$, $f = 1\text{ MHz}$, $V_{CC1} = 5\text{ V}$		2		pF	
CMTI	Common-mode transient immunity	$V_{\text{CM}} = 1500\text{ V}$, see Figure 41	100	120		kV/ μs	

- (1) Measured at same supply voltage and temperature condition
(2) Measured from input pin to ground.

7.11 Safety and Insulation Characteristics Curves

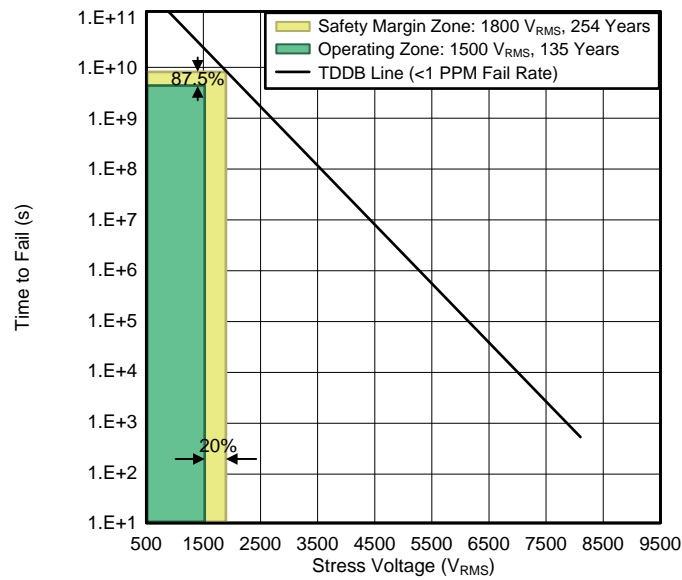

T_A upto 150°C Stress-voltage frequency = 60 Hz
Figure 1. Reinforced High-Voltage Capacitor Life Time Projection

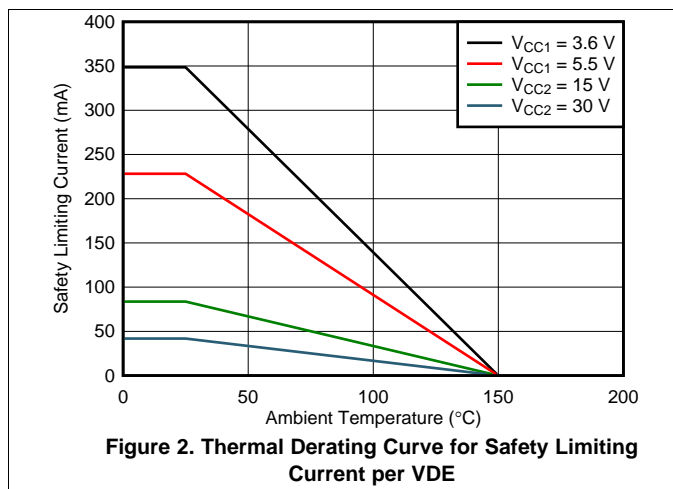

Figure 2. Thermal Derating Curve for Safety Limiting Current per VDE

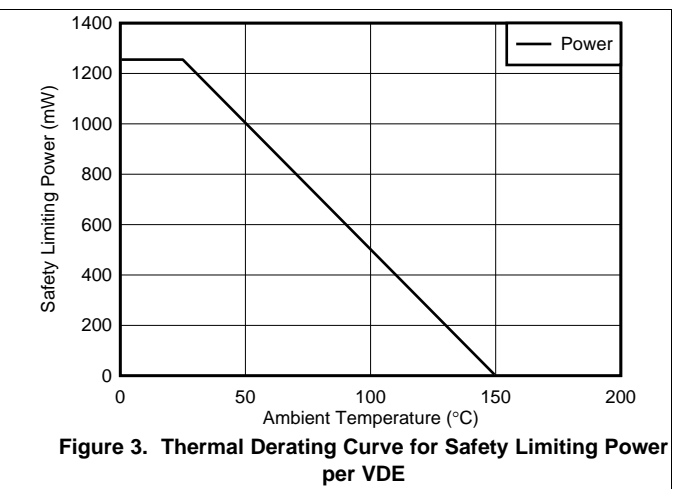
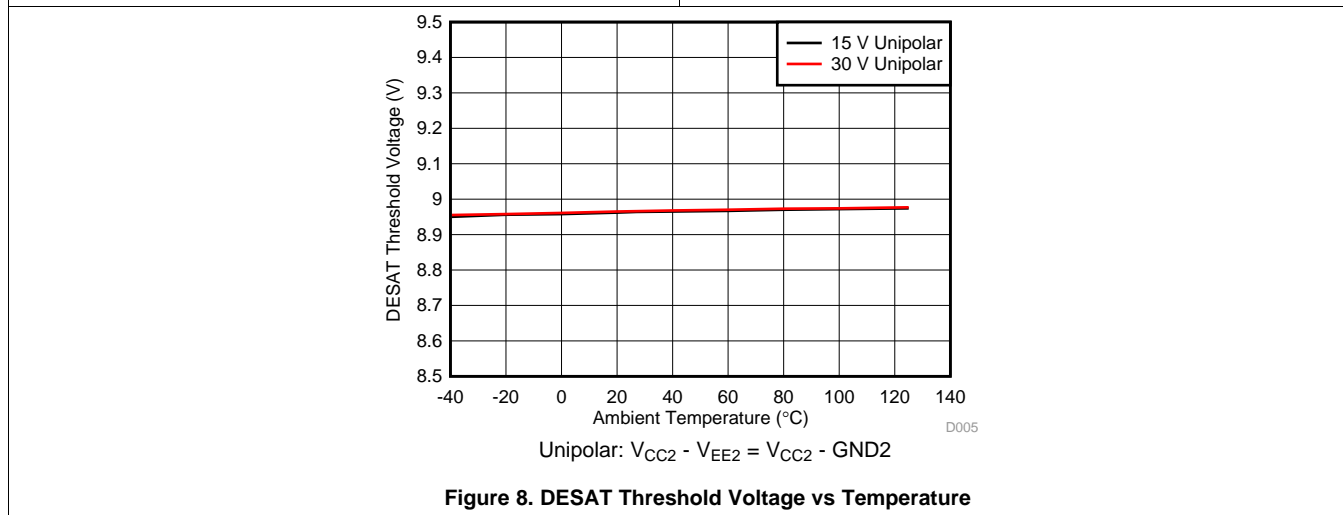
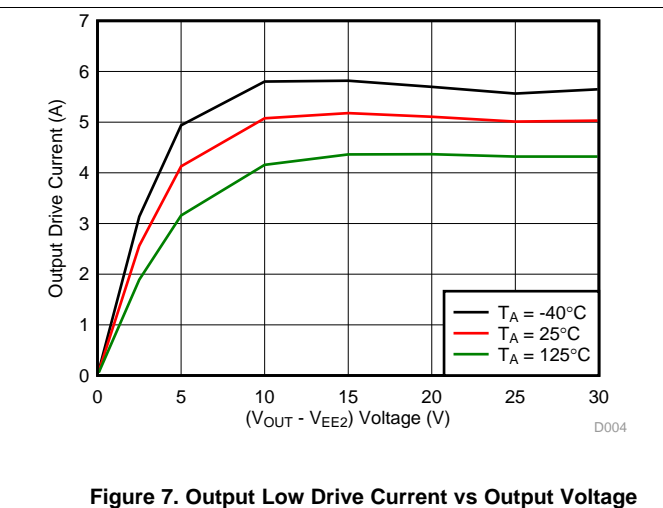
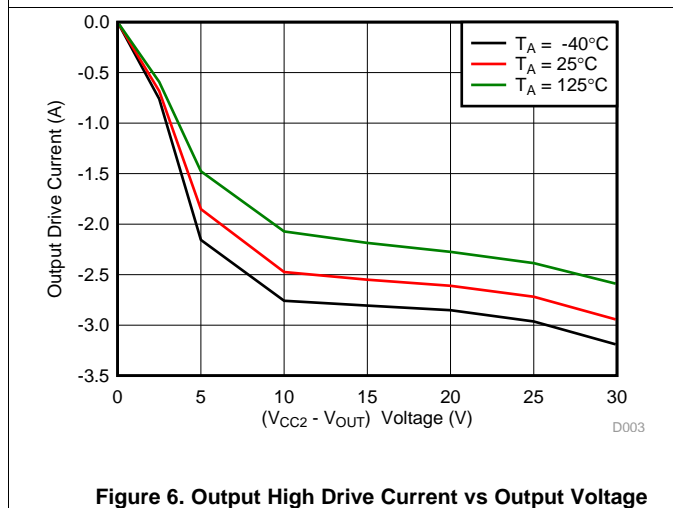
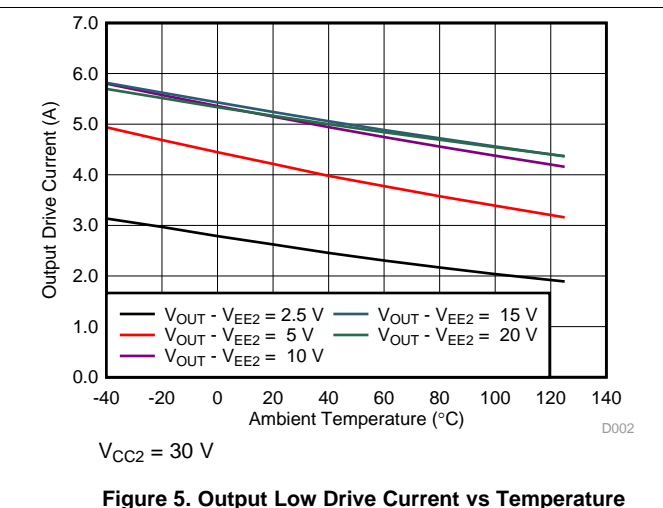
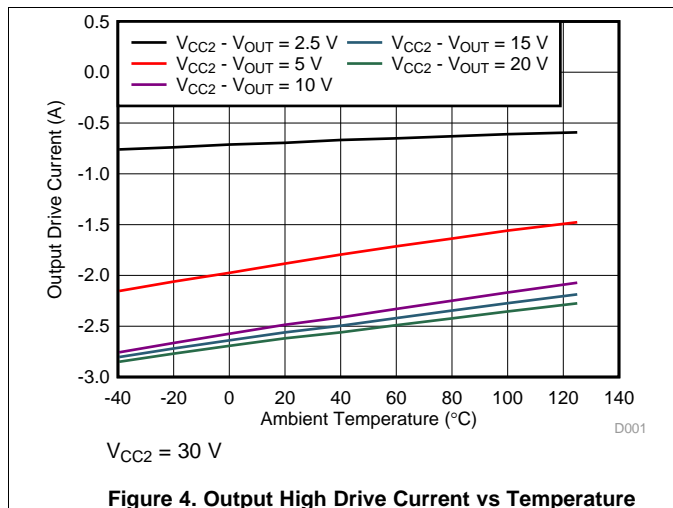
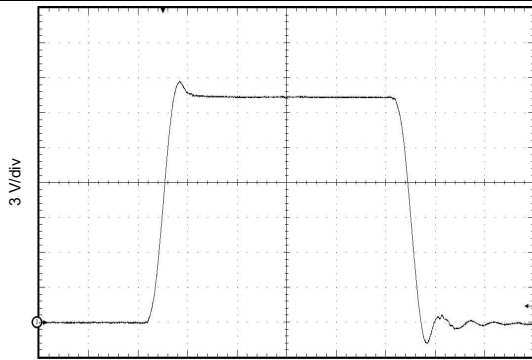

Figure 3. Thermal Derating Curve for Safety Limiting Power per VDE

7.12 Typical Characteristics



Typical Characteristics (continued)



$C_L = 1 \text{ nF}$ $R_G = 0 \Omega$
 $V_{CC2} - V_{EE2} = V_{CC2} - \text{GND2} = 20 \text{ V}$

Figure 9. OUT Transient Waveform

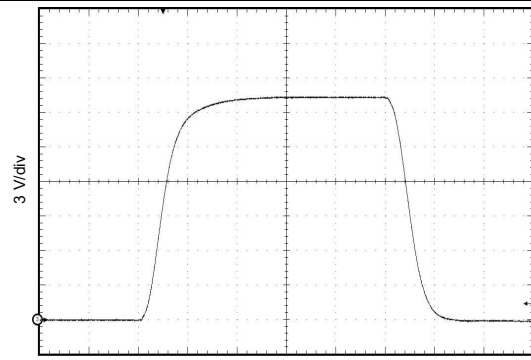

$C_L = 1 \text{ nF}$ $R_G = 10 \Omega$
 $V_{CC2} - V_{EE2} = V_{CC2} - \text{GND2} = 20 \text{ V}$

Figure 10. OUT Transient Waveform

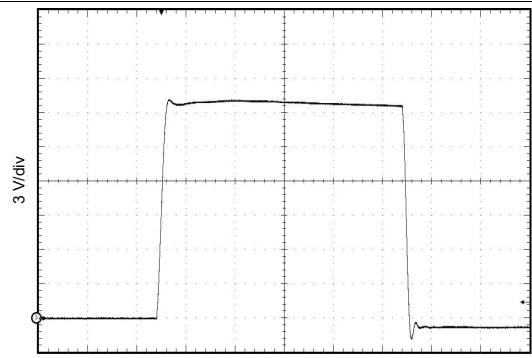

$C_L = 10 \text{ nF}$ $R_G = 0 \Omega$
 $V_{CC2} - V_{EE2} = V_{CC2} - \text{GND2} = 20 \text{ V}$

Figure 11. OUT Transient Waveform

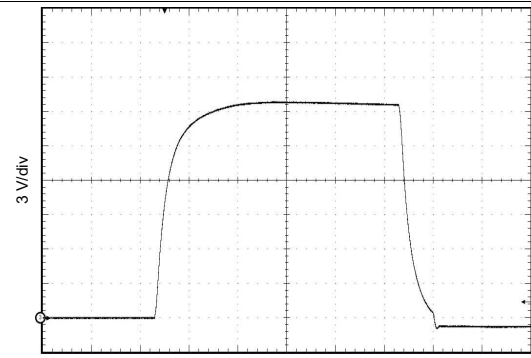

$C_L = 10 \text{ nF}$ $R_G = 10 \Omega$
 $V_{CC2} - V_{EE2} = V_{CC2} - \text{GND2} = 20 \text{ V}$

Figure 12. OUT Transient Waveform

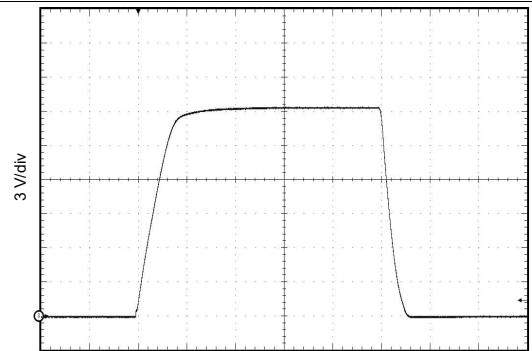

$C_L = 100 \text{ nF}$ $R_G = 0 \Omega$
 $V_{CC2} - V_{EE2} = V_{CC2} - \text{GND2} = 20 \text{ V}$

Figure 13. OUT Transient Waveform

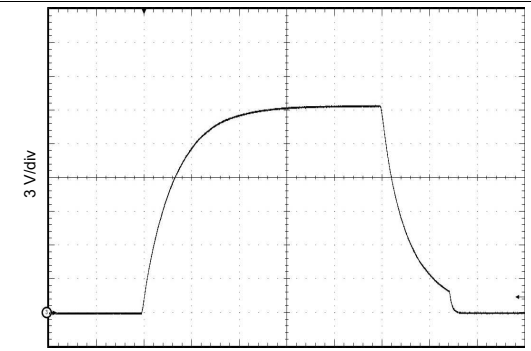

$C_L = 100 \text{ nF}$ $R_G = 10 \Omega$
 $V_{CC2} - V_{EE2} = V_{CC2} - \text{GND2} = 20 \text{ V}$

Figure 14. OUT Transient Waveform

Typical Characteristics (continued)

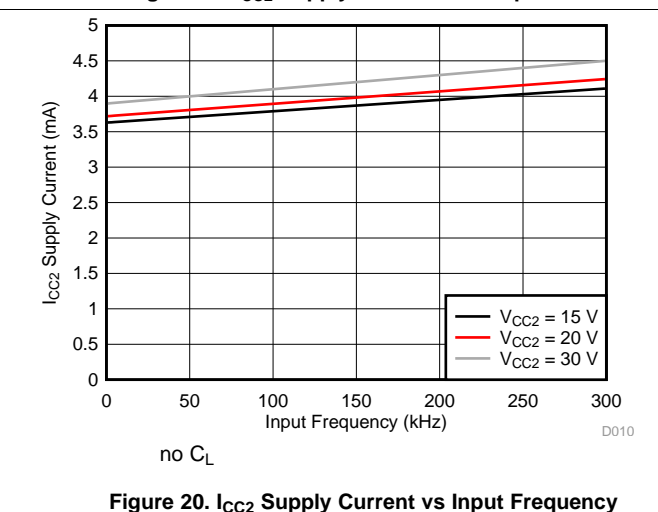
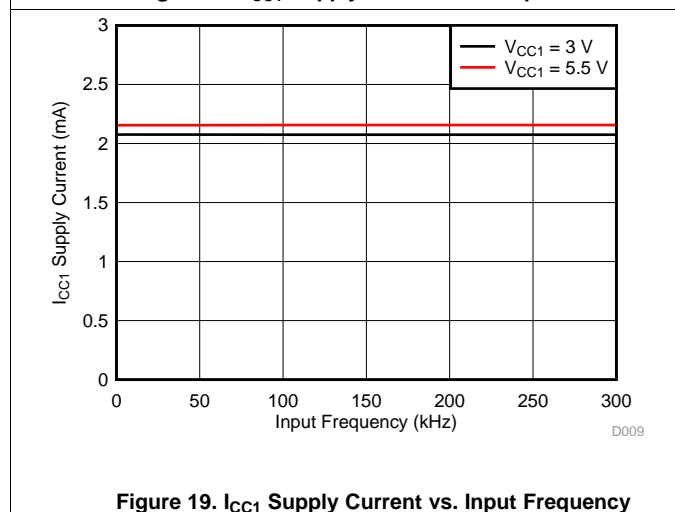
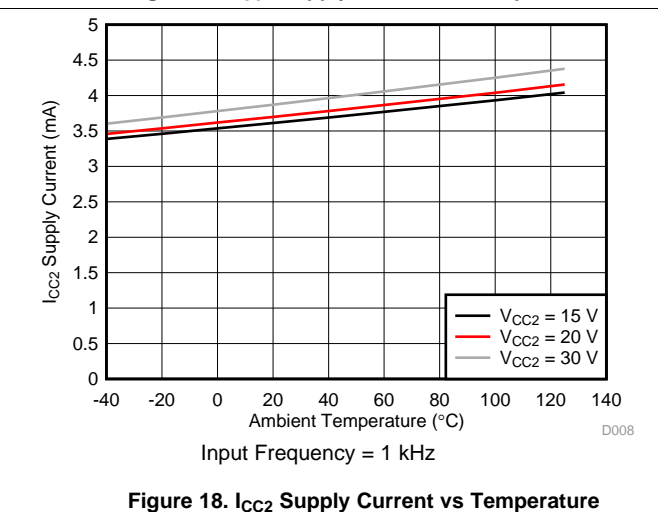
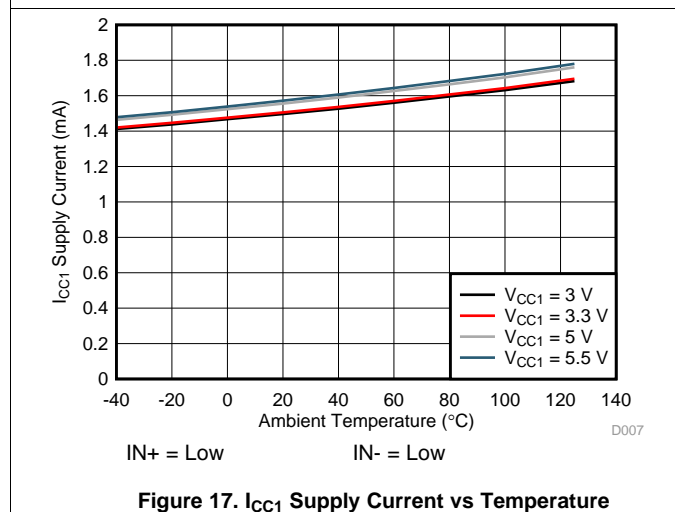
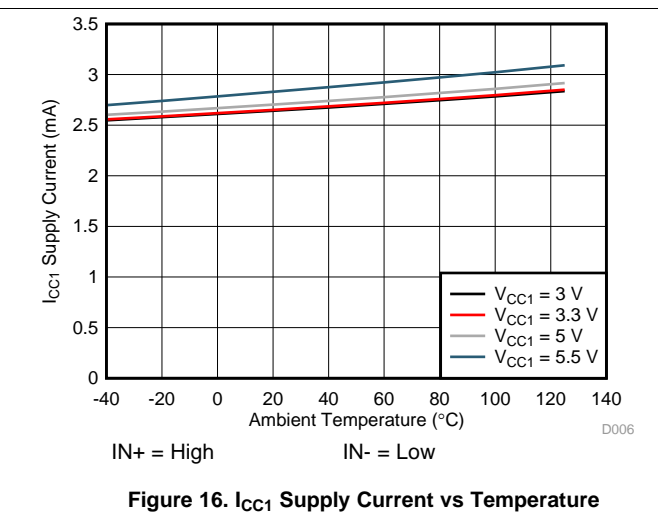
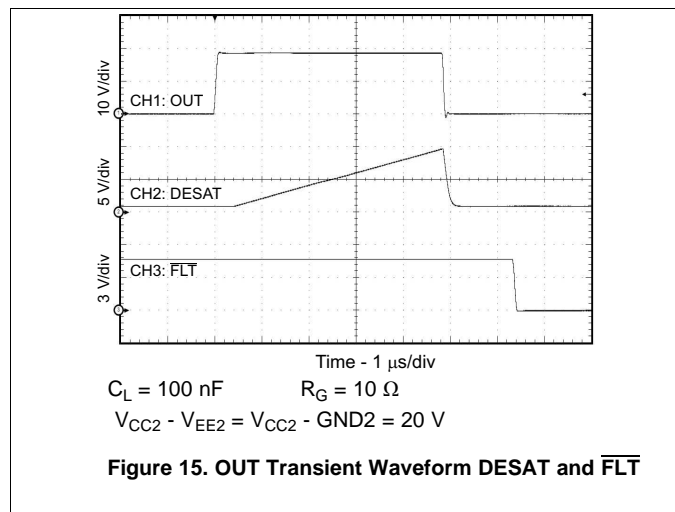

Typical Characteristics (continued)

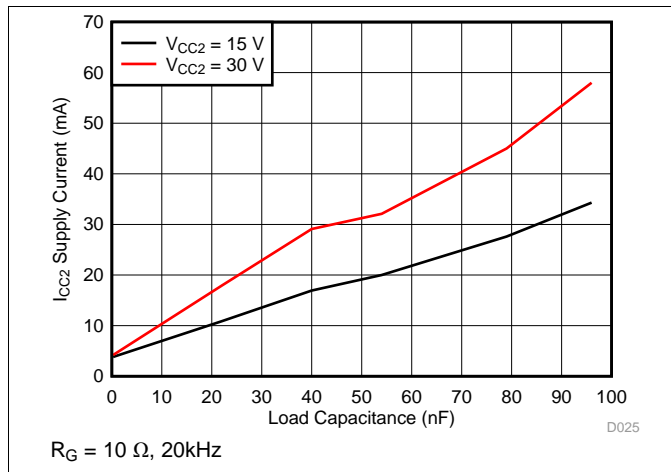

Figure 21. I_{CC2} Supply Current vs Load Capacitance

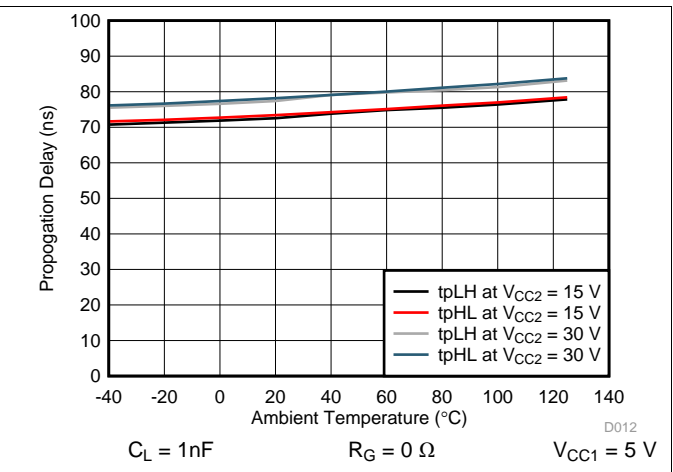

Figure 22. V_{CC1} Propagation Delay vs Temperature

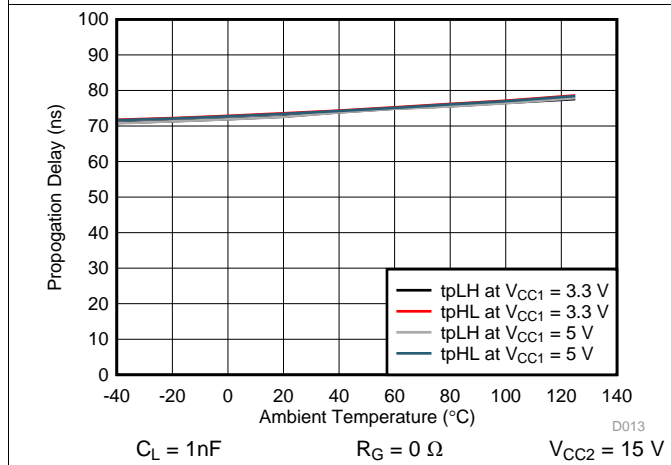

Figure 23. V_{CC2} Propagation Delay vs Temperature

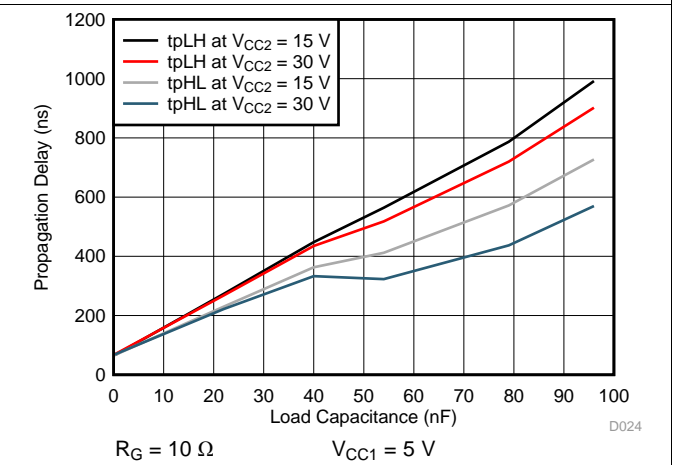

Figure 24. Propagation Delay vs Load Capacitance

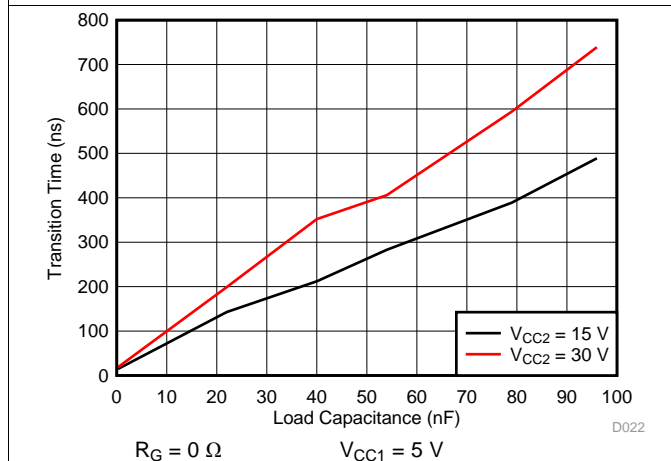

Figure 25. t_r Rise Time vs Load Capacitance

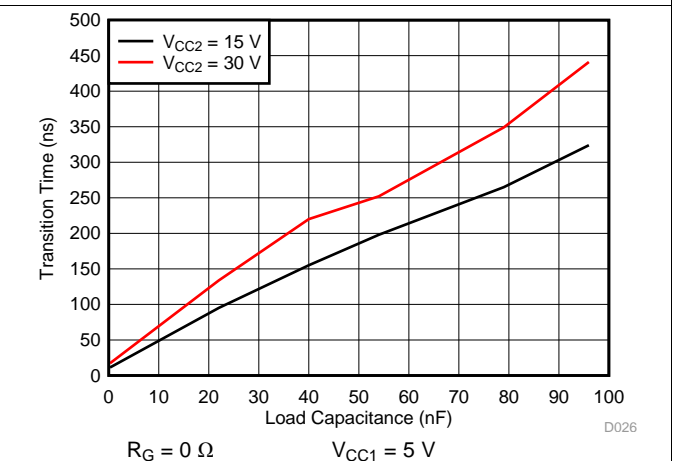

Figure 26. t_f Fall Time v. Load Capacitance

Typical Characteristics (continued)

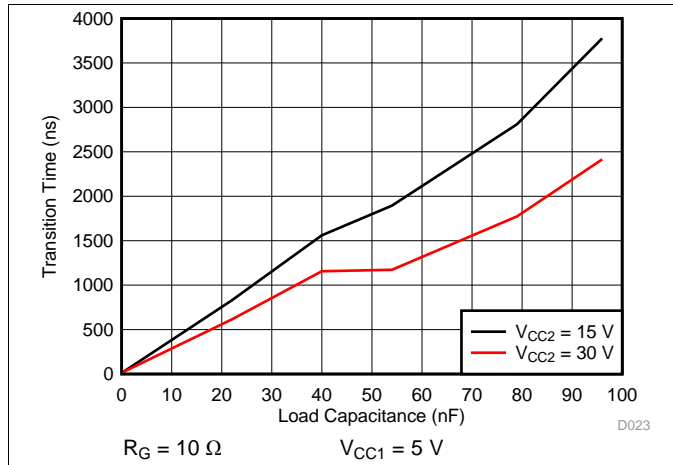

Figure 27. t_r Rise Time vs Load Capacitance

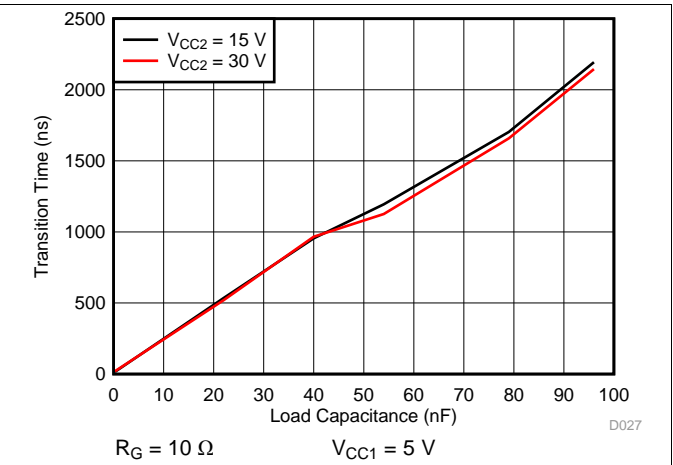

Figure 28. t_f Fall Time vs Load Capacitance

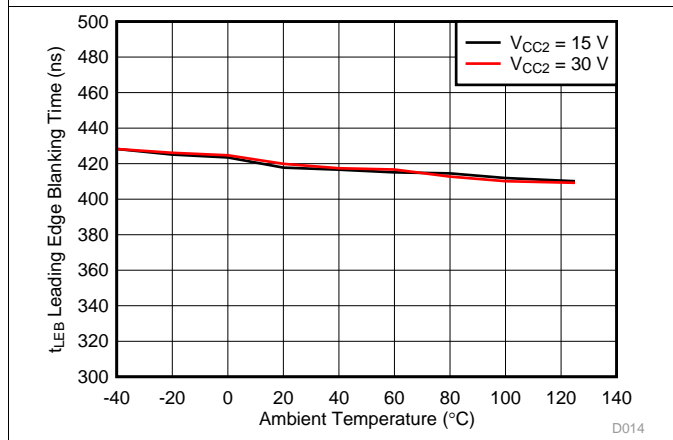

Figure 29. Leading Edge Blanking Time With Temperature

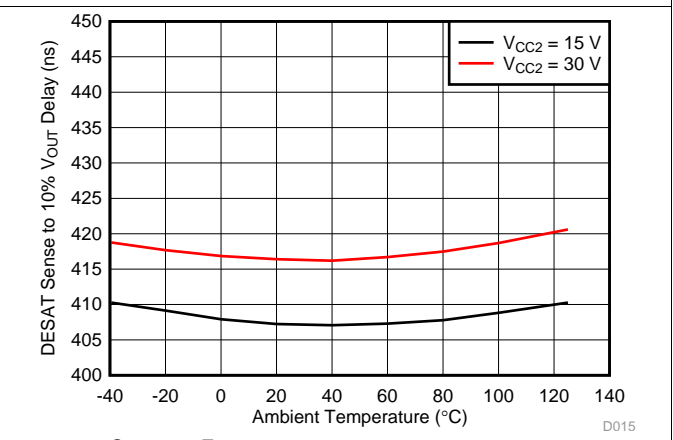

Figure 30. DESAT Sense to V_{OUT} 10% Delay vs Temperature

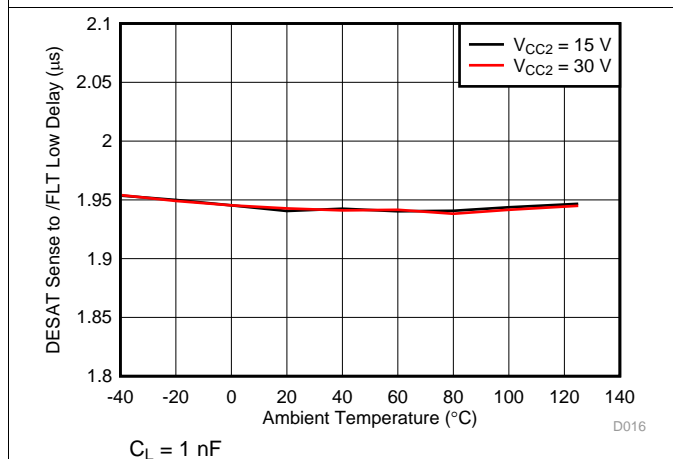

Figure 31. DESAT Sense to \overline{FLT} Low Delay vs Temperature

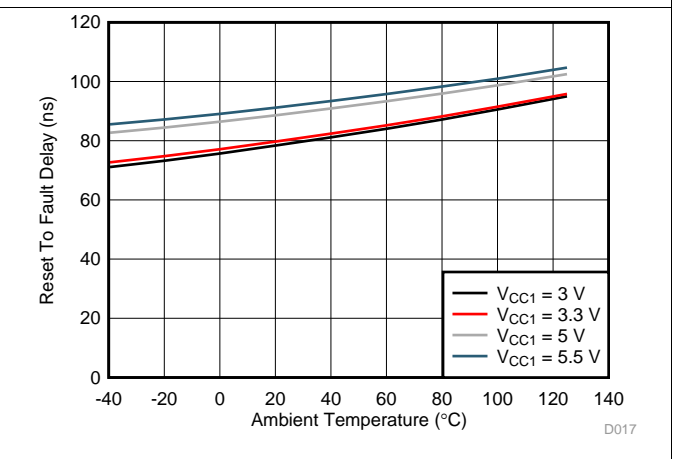

Figure 32. Reset to Fault Delay Across Temperature

Typical Characteristics (continued)

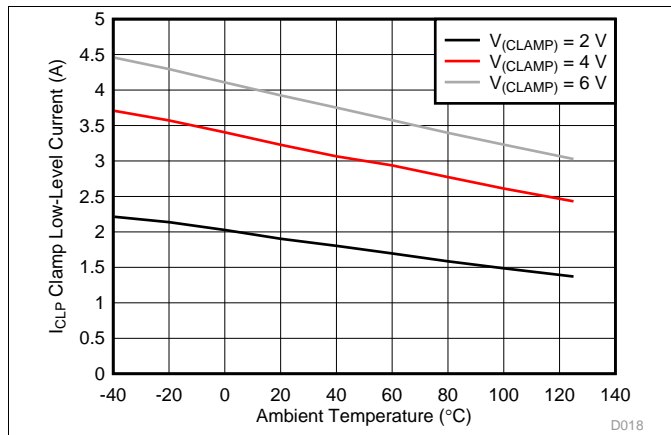

Figure 33. Miller Clamp Current vs Temperature

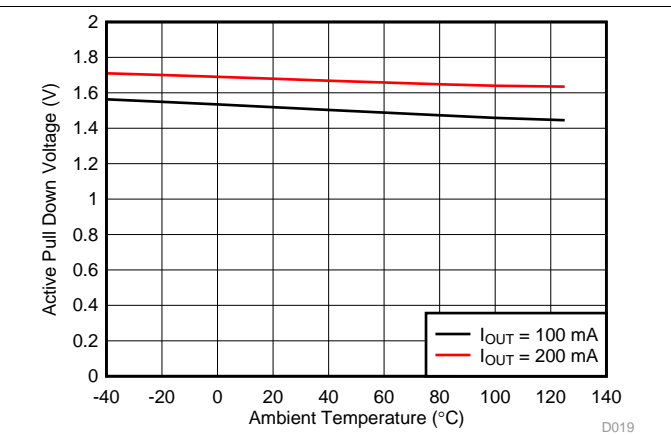

Figure 34. Active Pull Down Voltage vs Temperature

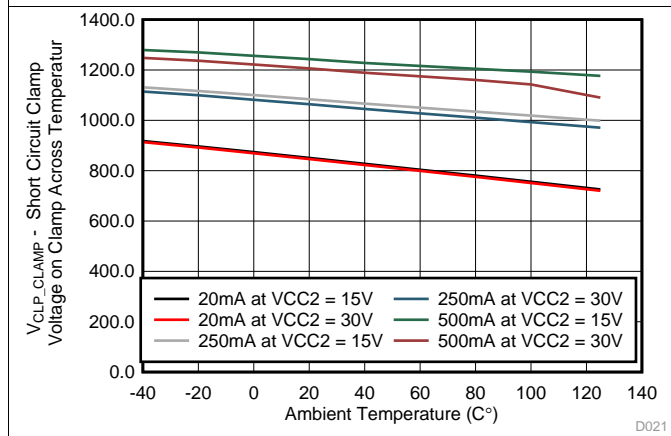

Figure 35. V_{CLP_CLAMP} - Short Circuit Clamp Voltage on Clamp Across Temperature

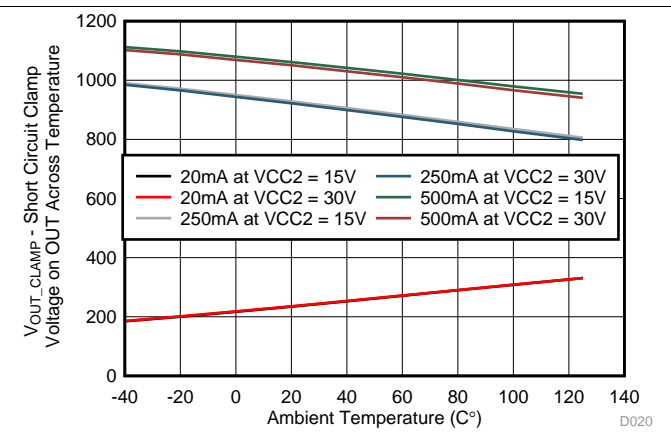

Figure 36. V_{OUT_CLAMP} - Short Circuit Clamp Voltage on OUT Across Temperature

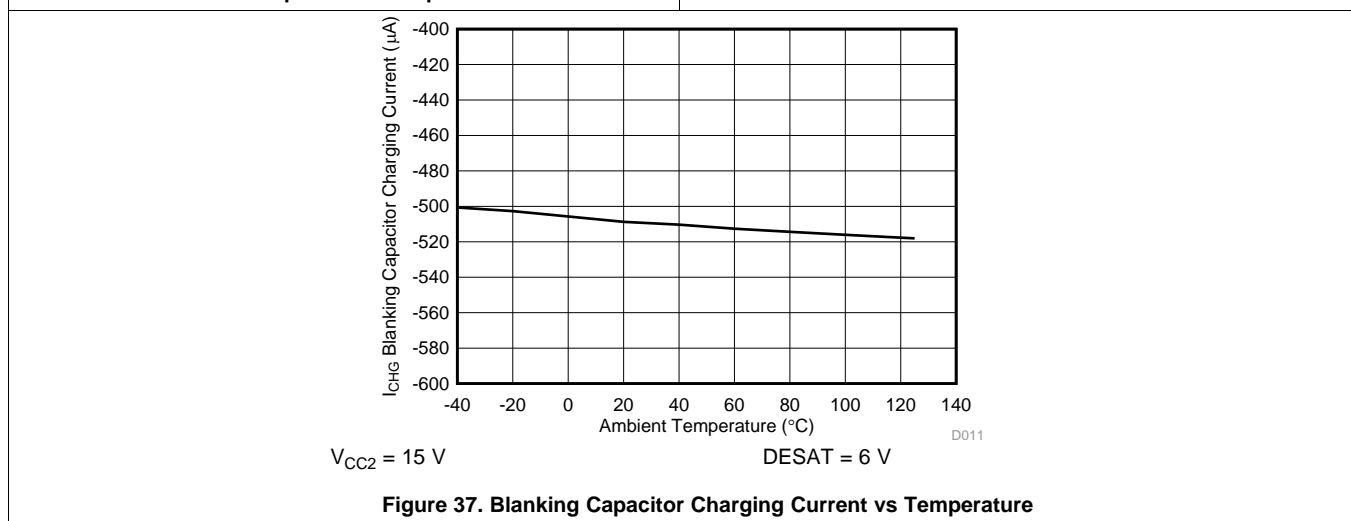

Figure 37. Blanking Capacitor Charging Current vs Temperature

8 Parameter Measurement Information

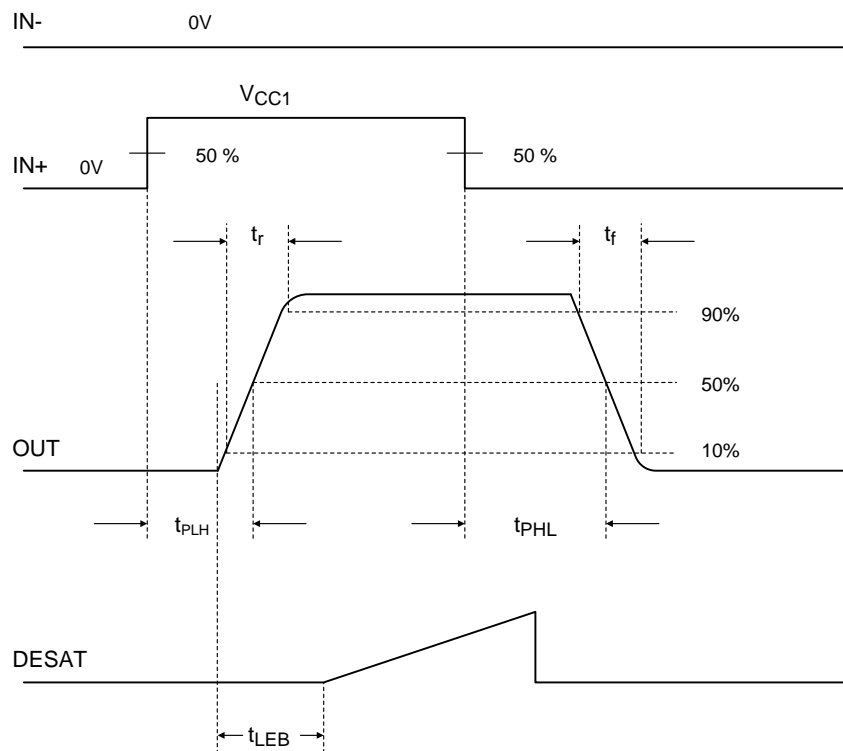

Figure 38. OUT Propagation Delay, Non-Inverting Configuration

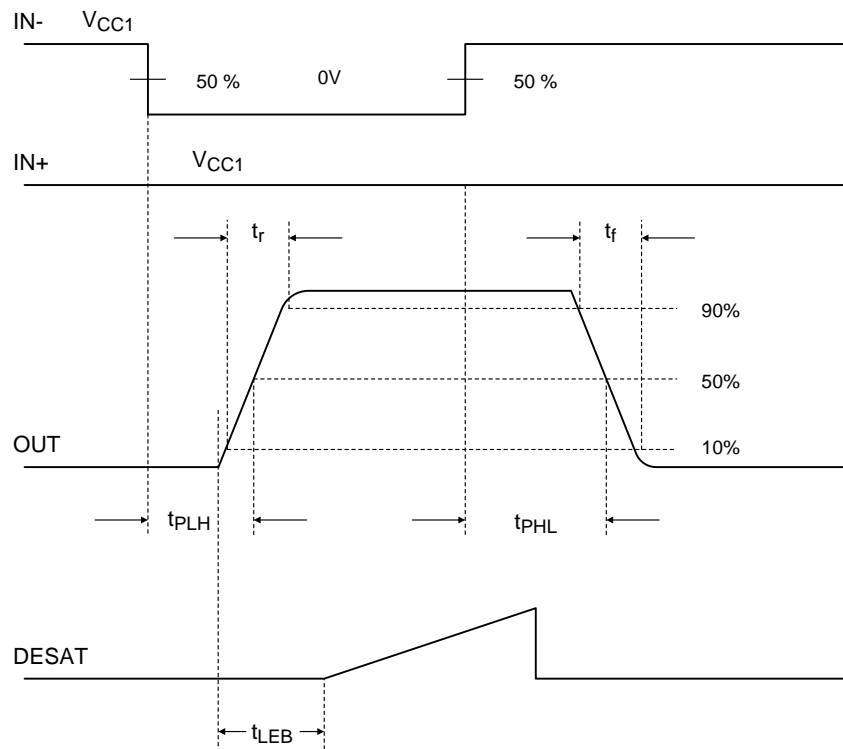

Figure 39. OUT Propagation Delay, Inverting Configuration

Parameter Measurement Information (continued)

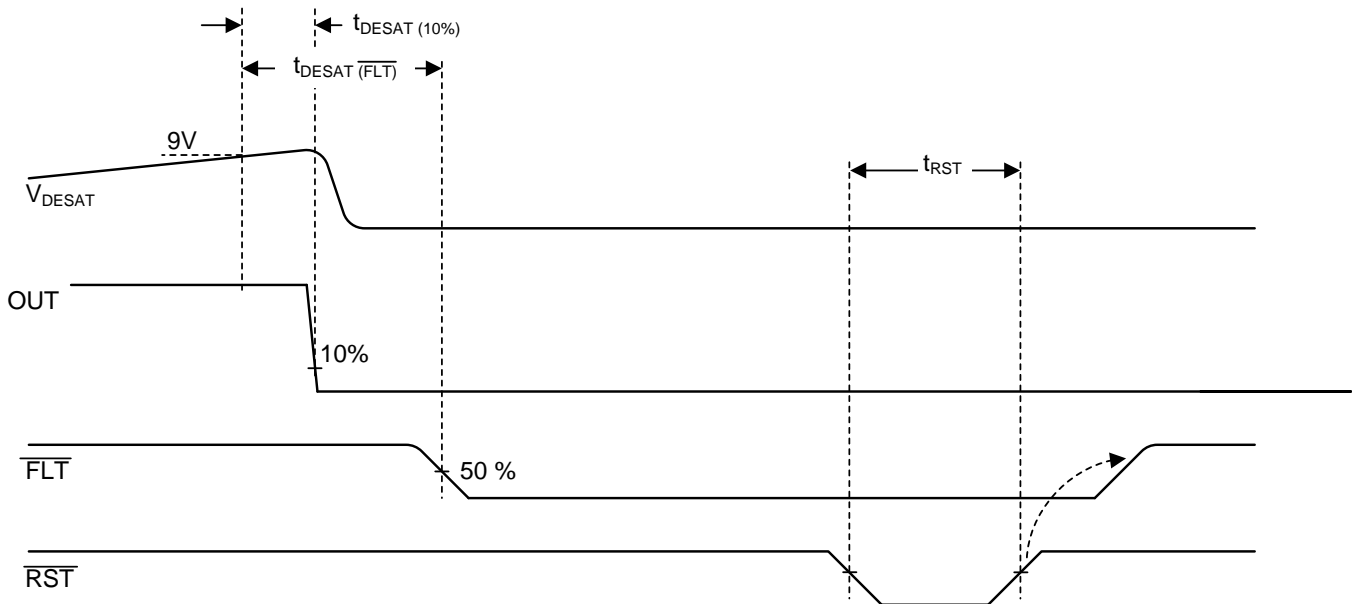
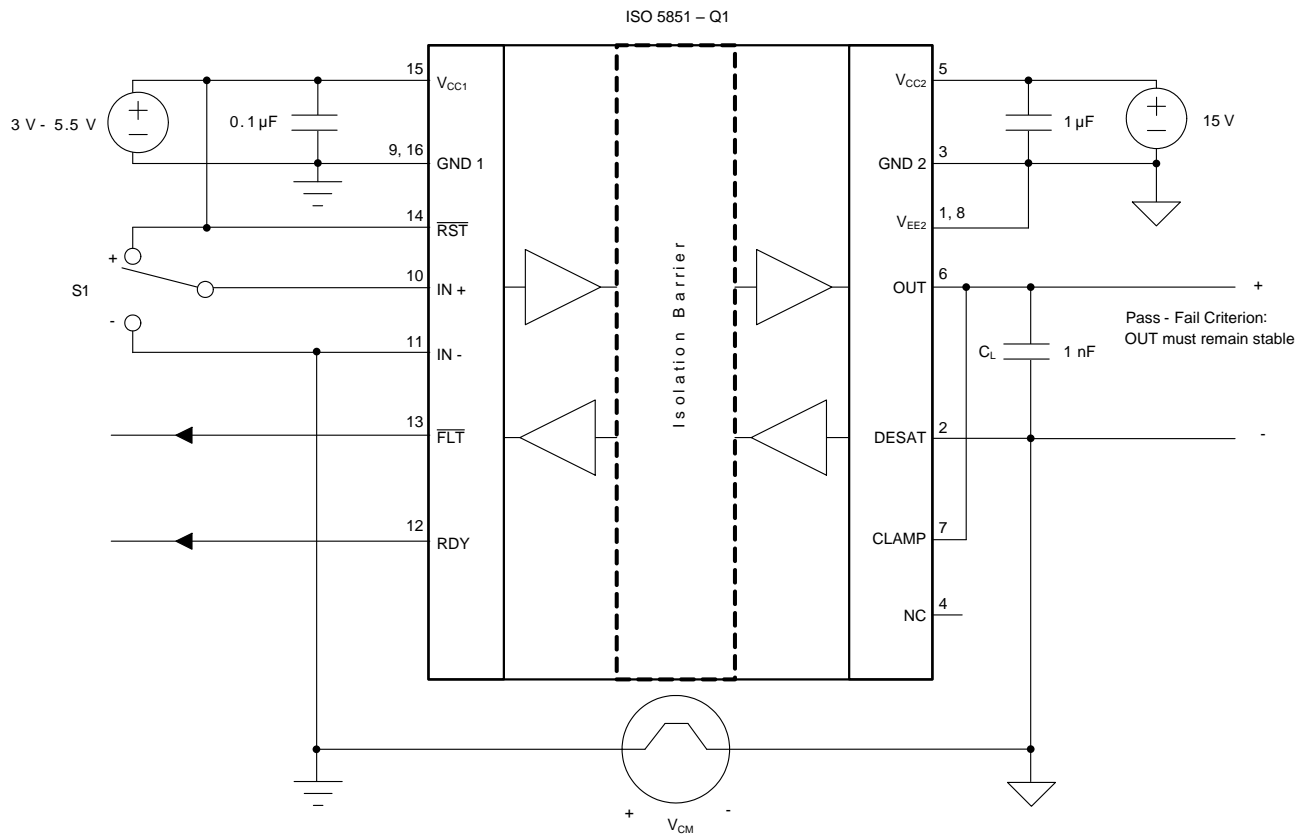

Figure 40. DESAT, OUT, $\overline{\text{FLT}}$, $\overline{\text{RST}}$ Delay



Copyright © 2016, Texas Instruments Incorporated

Figure 41. Common-Mode Transient Immunity Test Circuit

9 Detailed Description

9.1 Overview

The ISO5851-Q1 is an isolated gate driver for IGBTs and MOSFETs. Input CMOS logic and output power stage are separated by a capacitive, silicon dioxide (SiO₂), isolation barrier.

The IO circuitry on the input side interfaces with a micro controller and consists of gate drive control and RESET (RST) inputs, READY (RDY) and FAULT (FLT) alarm outputs. The power stage consists of power transistors to supply 2.5-A pull-up and 5-A pull-down currents to drive the capacitive load of the external power transistors, as well as DESAT detection circuitry to monitor IGBT collector-emitter overvoltage under short circuit events. The capacitive isolation core consists of transmit circuitry to couple signals across the capacitive isolation barrier, and receive circuitry to convert the resulting low-swing signals into CMOS levels. The ISO5851-Q1 also contains under voltage lockout circuitry to prevent insufficient gate drive to the external IGBT, and active output pull-down feature which ensures that the gate-driver output is held low, if the output supply voltage is absent. The ISO5851-Q1 also has an active Miller clamp function which can be used to prevent parasitic turn-on of the external power transistor, due to Miller effect, for unipolar supply operation.

9.2 Functional Block Diagram

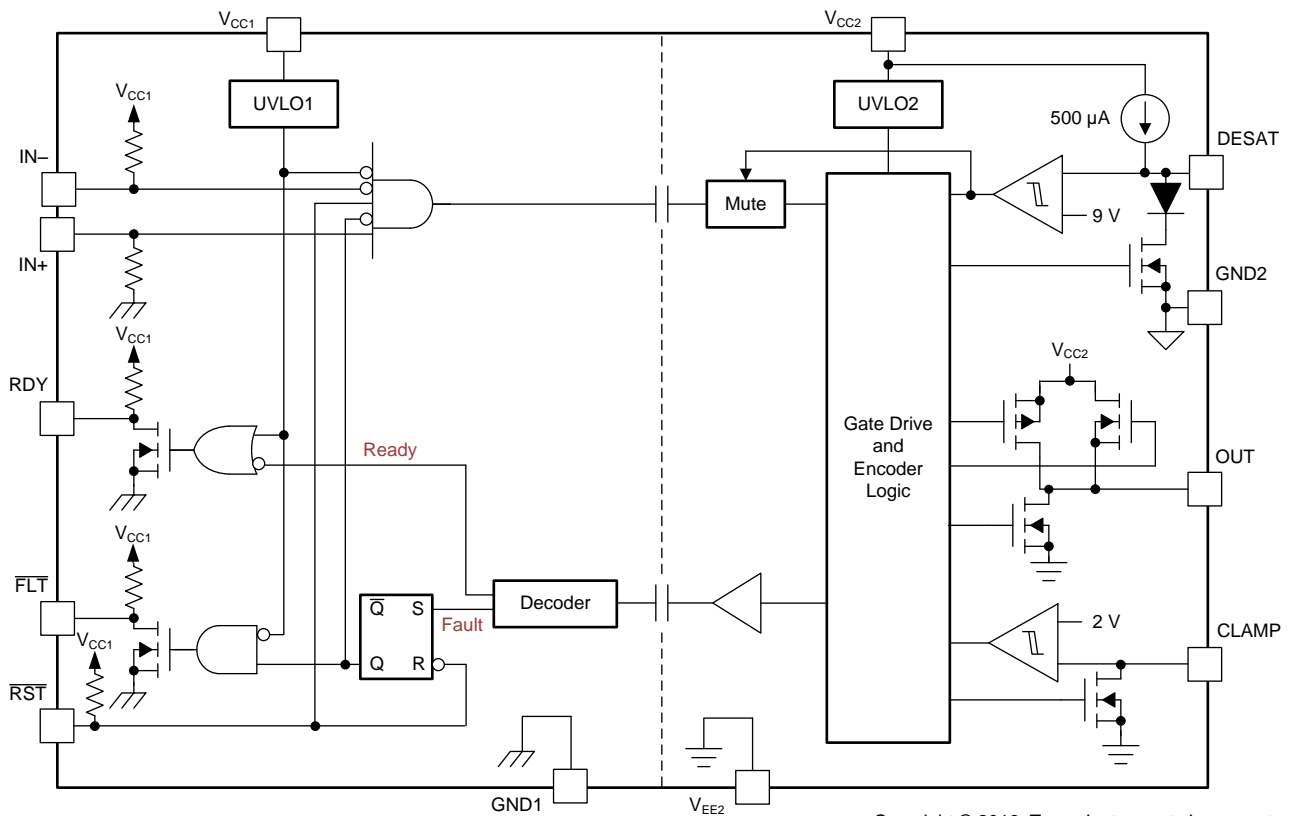

Copyright © 2016, Texas Instruments Incorporated

9.3 Feature Description

9.3.1 Supply and active Miller clamp

The ISO5851-Q1 supports both bipolar and unipolar power supply with active Miller clamp.

For operation with bipolar supplies, the IGBT is turned off with a negative voltage on its gate with respect to its emitter. This prevents the IGBT from unintentionally turning on because of current induced from its collector to its gate due to Miller effect. In this condition it is not necessary to connect CLAMP output of the gate driver to the IGBT gate, but connecting CLAMP output of the gate driver to the IGBT gate is also not an issue. Typical values of V_{CC2} and V_{EE2} for bipolar operation are 15-V and -8-V with respect to GND2.

For operation with unipolar supply, typically, V_{CC2} is connected to 15-V with respect to GND2, and V_{EE2} is connected to GND2. In this use case, the IGBT can turn-on due to additional charge from IGBT Miller capacitance caused by a high voltage slew rate transition on the IGBT collector. To prevent IGBT to turn on, the CLAMP pin is connected to IGBT gate and Miller current is sunk through a low impedance CLAMP transistor.

Miller CLAMP is designed for Miller current up to 2-A. When the IGBT is turned-off and the gate voltage transitions below 2-V the CLAMP current output is activated.

9.3.2 Active Output Pull-down

The Active output pull-down feature ensures that the IGBT gate OUT is clamped to V_{EE2} to ensure safe IGBT off-state when the output side is not connected to the power supply.

9.3.3 Undervoltage Lockout (UVLO) with Ready (RDY) Pin Indication Output

Undervoltage Lockout (UVLO) ensures correct switching of IGBT. The IGBT is turned-off, if the supply V_{CC1} drops below $V_{IT-(UVLO1)}$, irrespective of IN+, IN- and RST input till V_{CC1} goes above $V_{IT+(UVLO1)}$.

In similar manner, the IGBT is turned-off, if the supply V_{CC2} drops below $V_{IT-(UVLO2)}$, irrespective of IN+, IN- and RST input till V_{CC2} goes above $V_{IT+(UVLO2)}$.

Ready (RDY) pin indicates status of input and output side Under Voltage Lock-Out (UVLO) internal protection feature. If either side of device have insufficient supply (V_{CC1} or V_{CC2}), the RDY pin output goes low; otherwise, RDY pin output is high. RDY pin also serves as an indication to the micro-controller that the device is ready for operation.

9.3.4 Fault (\overline{FLT}) and Reset (\overline{RST})

During IGBT overload condition, to report desaturation error \overline{FLT} goes low. If \overline{RST} is held low for the specified duration, FLT is cleared at rising edge of RST. RST has an internal filter to reject noise and glitches. By asserting RST for at-least the specified minimum duration, device input logic can be enabled or disabled.

9.3.5 Short Circuit Clamp

Under short circuit events it is possible that currents are induced back into the gate-driver OUT and CLAMP pins due to parasitic Miller capacitance between the IGBT collector and gate terminals. Internal protection diodes on OUT and CLAMP help to sink these currents while clamping the voltages on these pins to values slightly higher than the output side supply.

9.4 Device Functional Modes

Table 1 lists the functional modes for the ISO5851-Q1 device.

In ISO5851-Q1 OUT to follow IN+ in normal functional mode, $\overline{\text{FLT}}$ needs to be in high state.

Table 1. Function Table⁽¹⁾

V _{CC1}	V _{CC2}	IN+	IN-	$\overline{\text{RST}}$	RDY	OUT
PU	PD	X	X	X	Low	Low
PD	PU	X	X	X	Low	Low
PU	PU	X	X	Low	High	Low
PU	Open	X	X	X	Low	Low
PU	PU	Low	X	X	High	Low
PU	PU	X	High	X	High	Low
PU	PU	High	Low	High	High	High

(1) PU: Power Up ($V_{CC1} \geq 2.25\text{-V}$, $V_{CC2} \geq 13\text{-V}$), PD: Power Down ($V_{CC1} \leq 1.7\text{-V}$, $V_{CC2} \leq 9.5\text{-V}$), X: Irrelevant

10 Application and Implementation

NOTE

Information in the following applications sections is not part of the TI component specification, and TI does not warrant its accuracy or completeness. TI's customers are responsible for determining suitability of components for their purposes. Customers should validate and test their design implementation to confirm system functionality.

10.1 Application Information

The ISO5851-Q1 is an isolated gate driver for power semiconductor devices such as IGBTs and MOSFETs. It is intended for use in applications such as motor control, industrial inverters and switched mode power supplies. In these applications, sophisticated PWM control signals are required to turn the power devices on and off, which at the system level eventually may determine, for example, the speed, position, and torque of the motor or the output voltage, frequency and phase of the inverter. These control signals are usually the outputs of a micro controller, and are at low voltage levels such as 3.3-V or 5-V. The gate controls required by the MOSFETs and IGBTs, on the other hand, are in the range of 30-V (using Unipolar Output Supply) to 15-V (using Bipolar Output Supply), and need high current capability to be able to drive the large capacitive loads offered by those power transistors. Not only that, the gate drive needs to be applied with reference to the Emitter of the IGBT (Source for MOSFET), and by construction, the Emitter node in a gate drive system may swing between 0 to the DC bus voltage, that can be several 100s of volts in magnitude.

The ISO5851-Q1 is thus used to level shift the incoming 3.3-V and 5-V control signals from the microcontroller to the 30-V (using Unipolar Output Supply) to 15-V (using Bipolar Output Supply) drive required by the power transistors while ensuring high-voltage isolation between the driver side and the microcontroller side.

10.2 Typical Applications

Figure 42 shows the typical application of a three-phase inverter using six ISO5851-Q1 isolated gate drivers. Three-phase inverters are used for variable-frequency drives to control the operating speed and torque of AC motors and for high power applications such as High-Voltage DC (HVDC) power transmission.

The basic three-phase inverter consists of six power switches, and each switch is driven by one ISO5851-Q1. The switches are driven on and off at high switching frequency with specific patterns that to converter dc bus voltage to three-phase AC voltages.

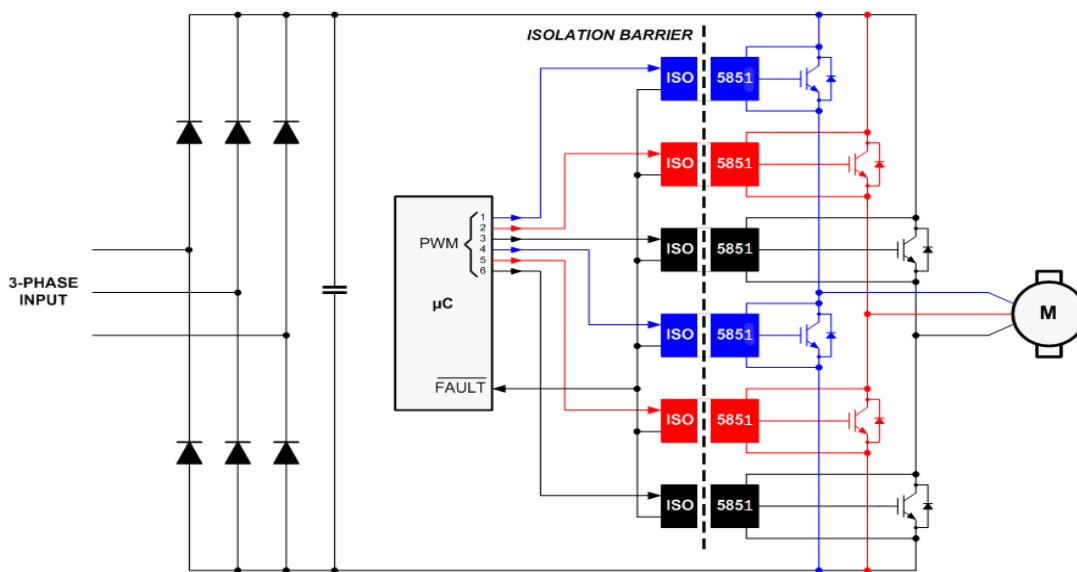

Copyright © 2016, Texas Instruments Incorporated

Figure 42. Typical Motor Drive Application

Typical Applications (continued)

10.2.1 Design Requirements

Unlike optocoupler based gate drivers which need external current drivers and biasing circuitry to provide the input control signals, the input control to the ISO5851-Q1 is CMOS and can be directly driven by the microcontroller. Other design requirements include decoupling capacitors on the input and output supplies, a pullup resistor on the common drain FLT output signal and RST input signal, and a high-voltage protection diode between the IGBT collector and the DESAT input. Further details are explained in the subsequent sections. Table 2 shows the allowed range for Input and Output supply voltage, and the typical current output available from the gate-driver.

Table 2. Design Parameters

PARAMETER	VALUE
Input supply voltage	3-V to 5.5-V
Unipolar output supply voltage ($V_{CC2} - GND2 = V_{CC2} - V_{EE2}$)	15-V to 30-V
Bipolar output supply voltage ($V_{CC2} - V_{EE2}$)	15-V to 30-V
Bipolar output supply voltage ($GND2 - V_{EE2}$)	0-V to 15-V
Output current	2.5-A

10.2.2 Detailed Design Procedure

10.2.2.1 Recommended ISO5851-Q1 Application Circuit

The ISO5851-Q1 has both, inverting and non-inverting gate control inputs, an active low reset input, and an open drain fault output suitable for wired-OR applications. The recommended application circuit in Figure 43 illustrates a typical gate driver implementation with Unipolar Output Supply and Figure 44 illustrates a typical gate driver implementation with Bipolar Output Supply using the ISO5851-Q1.

A 0.1- μ F bypass capacitor, recommended at input supply pin V_{CC1} and 1- μ F bypass capacitor, recommended at output supply pin V_{CC2} , provide the large transient currents necessary during a switching transition to ensure reliable operation. The 220 pF blanking capacitor disables DESAT detection during the off-to-on transition of the power device. The DESAT diode (D_{DST}) and its 1-k Ω series resistor are external protection components. The R_G gate resistor limits the gate charge current and indirectly controls the IGBT collector voltage rise and fall times. The open-drain FLT output and RDY output has a passive 10-k Ω pull-up resistor. In this application, the IGBT gate driver is disabled when a fault is detected and will not resume switching until the micro-controller applies a reset signal.

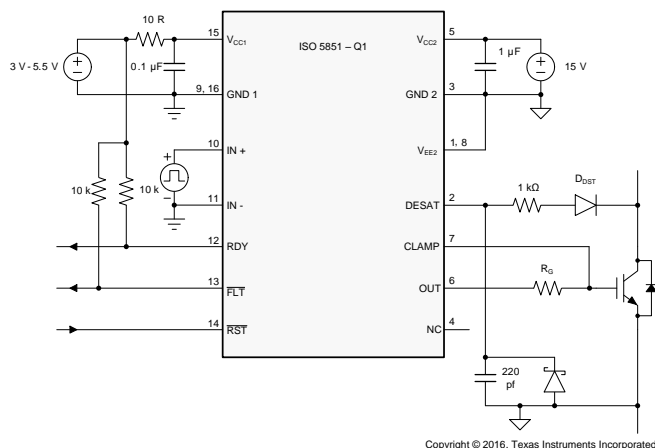

Figure 43. Unipolar Output Supply

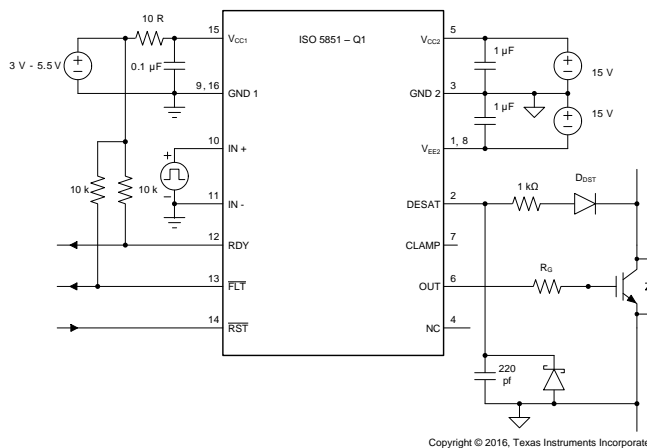
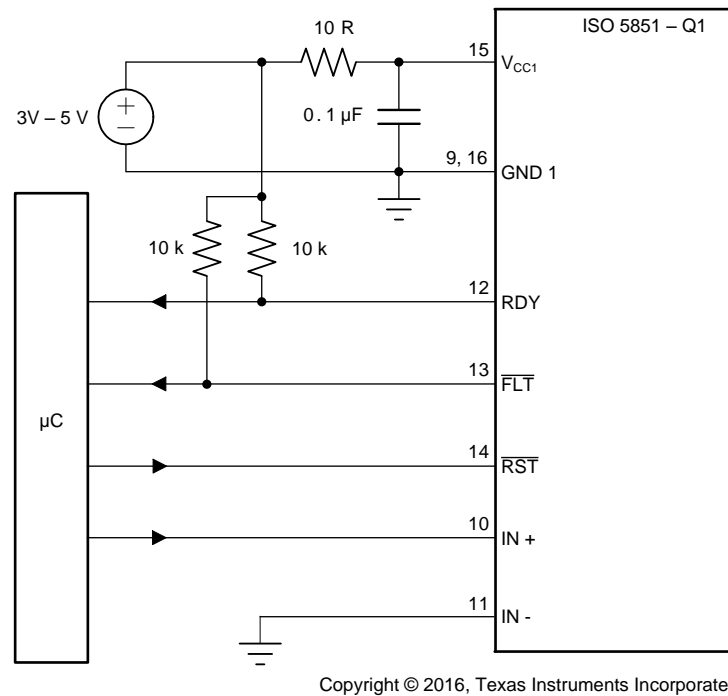

Figure 44. Bipolar Output Supply

10.2.2.2 \overline{FLT} and RDY Pin Circuitry

There is 50k pull-up resistor internally on \overline{FLT} and RDY pins. The \overline{FLT} and RDY pin is an open-drain output. A 10-k Ω pull-up resistor can be used to make it faster rise and to provide logic high when \overline{FLT} and RDY is inactive, as shown in Figure 45

Fast common mode transients can inject noise and glitches on \overline{FLT} and RDY pins due to parasitic coupling. This is dependent on board layout. If required, additional capacitance (100 pF to 300 pF) can be included on the \overline{FLT} and RDY pins.



Copyright © 2016, Texas Instruments Incorporated

Figure 45. \overline{FLT} and RDY Pin Circuitry for High CMTI

10.2.2.3 Driving the Control Inputs

The amount of common-mode transient immunity (CMTI) can be curtailed by the capacitive coupling from the high-voltage output circuit to the low-voltage input side of the ISO5851-Q1. For maximum CMTI performance, the digital control inputs, IN+ and IN-, must be actively driven by standard CMOS, push-pull drive circuits. This type of low-impedance signal source provides active drive signals that prevent unwanted switching of the ISO5851-Q1 output under extreme common-mode transient conditions. Passive drive circuits, such as open-drain configurations using pull-up resistors, must be avoided. There is a 20 ns glitch filter which can filter a glitch up to 20 ns on IN+ or IN-.

10.2.2.4 Local Shutdown and Reset

In applications with local shutdown and reset, the $\overline{\text{FLT}}$ output of each gate driver is polled separately, and the individual reset lines are asserted low independently to reset the motor controller after a fault condition.

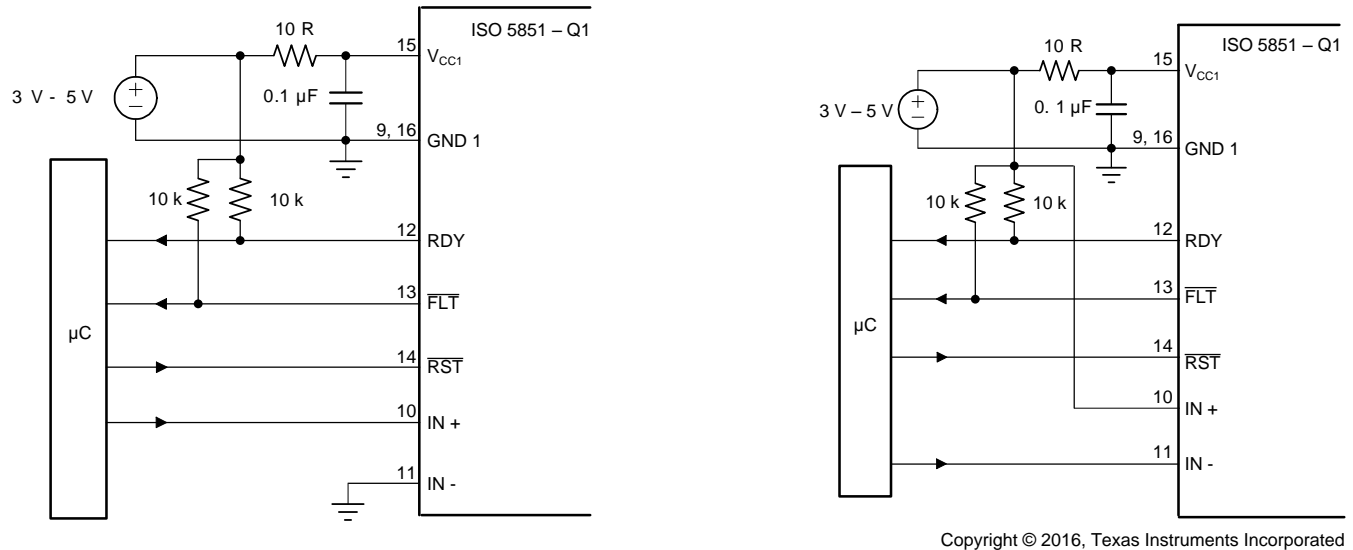

Copyright © 2016, Texas Instruments Incorporated

Figure 46. Local Shutdown and Reset for Noninverting (left) and Inverting Input Configuration (right)

10.2.2.5 Global-Shutdown and Reset

When configured for inverting operation, the ISO5851-Q1 can be configured to shutdown automatically in the event of a fault condition by tying the $\overline{\text{FLT}}$ output to IN+. For high reliability drives, the open drain $\overline{\text{FLT}}$ outputs of multiple ISO5851-Q1 devices can be wired together forming a single, common fault bus for interfacing directly to the micro-controller. When any of the six gate drivers of a three-phase inverter detects a fault, the active low $\overline{\text{FLT}}$ output disables all six gate drivers simultaneously.

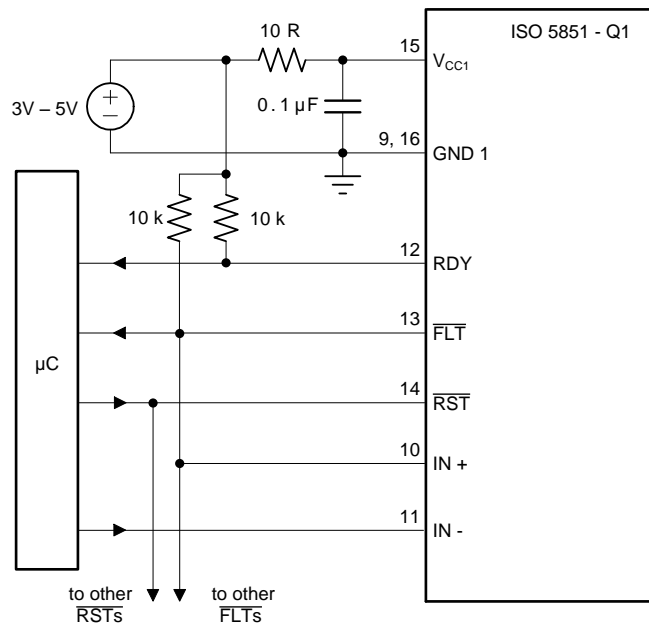

Copyright © 2016, Texas Instruments Incorporated

Figure 47. Global Shutdown with Inverting Input Configuration

10.2.2.6 Auto-Reset

In this case, the gate control signal at IN+ is also applied to the $\overline{\text{RST}}$ input to reset the fault latch every switching cycle. Incorrect RST makes output go low. A fault condition, however, the gate driver remains in the latched fault state until the gate control signal changes to the 'gate low' state and resets the fault latch.

If the gate control signal is a continuous PWM signal, the fault latch will always be reset before IN+ goes high again. This configuration protects the IGBT on a cycle by cycle basis and automatically resets before the next 'on' cycle.

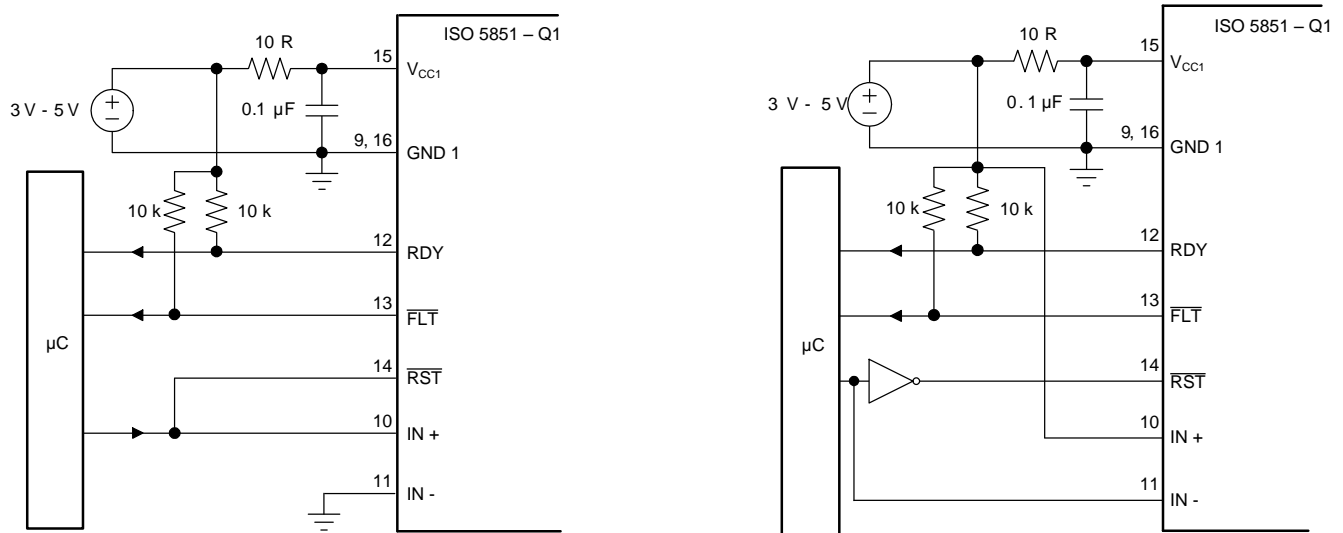

Copyright © 2016, Texas Instruments Incorporated

Figure 48. Auto Reset for Non-inverting and Inverting Input Configuration

10.2.2.7 DESAT Pin Protection

Switching inductive loads causes large instantaneous forward voltage transients across the freewheeling diodes of IGBTs. These transients result in large negative voltage spikes on the DESAT pin which draw substantial current out of the device. To limit this current below damaging levels, a 100-Ω to 1-kΩ resistor is connected in series with the DESAT diode.

Further protection is possible through an optional Schottky diode, whose low forward voltage assures clamping of the DESAT input to GND2 potential at low voltage levels.

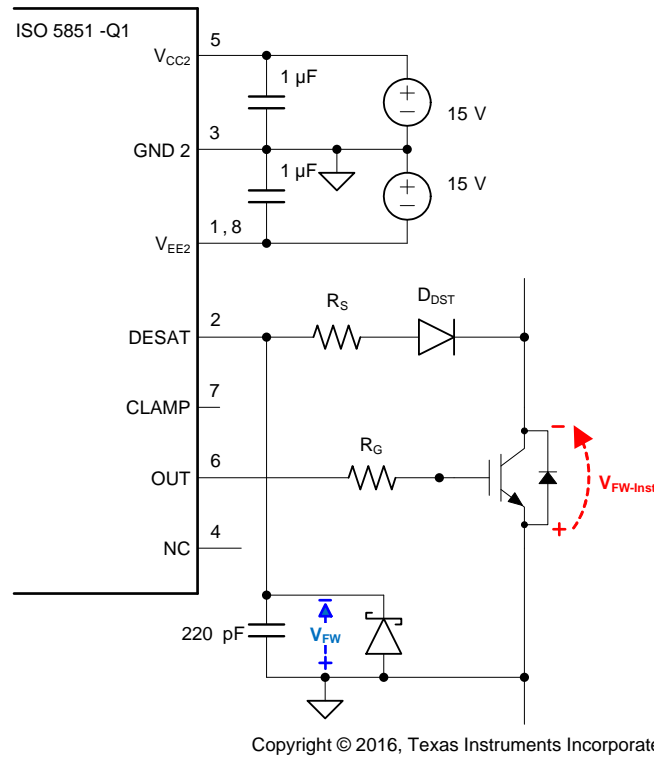

Figure 49. DESAT Pin Protection with Series Resistor and Schottky Diode

10.2.2.8 DESAT Diode and DESAT Threshold

The DESAT diode's function is to conduct forward current, allowing sensing of the IGBT's saturated collector-to-emitter voltage, $V_{(CESAT)}$, (when the IGBT is "on") and to block high voltages (when the IGBT is "off"). During the short transition time when the IGBT is switching, there is commonly a high dV_{CE}/dt voltage ramp rate across the IGBT. This results in a charging current $I_{(CHARGE)} = C_{(D-DESAT)} \times dV_{CE}/dt$, charging the blanking capacitor. $C_{(D-DESAT)}$ is the diode capacitance at DESAT.

To minimize this current and avoid false DESAT triggering, fast switching diodes with low capacitance are recommended. As the diode capacitance builds a voltage divider with the blanking capacitor, large collector voltage transients appear at DESAT attenuated by the ratio of $1 + C_{(BLANK)} / C_{(D-DESAT)}$.

Because the sum of the DESAT diode forward-voltage and the IGBT collector-emitter voltage make up the voltage at the DESAT-pin, $V_F + V_{CE} = V_{(DESAT)}$, the V_{CE} level, which triggers a fault condition, can be modified by adding multiple DESAT diodes in series: $V_{CE-FAULT(TH)} = 9\text{ V} - n \times VF$ (where n is the number of DESAT diodes).

When using two diodes instead of one, diodes with half the required maximum reverse-voltage rating may be chosen.

10.2.2.9 Determining the Maximum Available, Dynamic Output Power, P_{OD-max}

The ISO5851-Q1 maximum allowed total power consumption of $P_D = 251\text{ mW}$ consists of the total input power, P_{ID} , the total output power, P_{OD} , and the output power under load, P_{OL} :

$$P_D = P_{ID} + P_{OD} + P_{OL} \quad (1)$$

With:

$$P_{ID} = V_{CC1-max} \times I_{CC1-max} = 5.5\text{ V} \times 4.5\text{ mA} = 24.75\text{ mW} \quad (2)$$

and:

$$P_{OD} = (V_{CC2} - V_{EE2}) \times I_{CC2-max} = (15\text{ V} - (-8\text{ V})) \times 6\text{ mA} = 138\text{ mW} \quad (3)$$

then:

$$P_{OL} = P_D - P_{ID} - P_{OD} = 251\text{ mW} - 24.75\text{ mW} - 138\text{ mW} = 88.25\text{ mW} \quad (4)$$

In comparison to P_{OL} , the actual dynamic output power under worst case condition, P_{OL-WC} , depends on a variety of parameters:

$$P_{OL-WC} = 0.5 \times f_{INP} \times Q_G \times (V_{CC2} - V_{EE2}) \times \left(\frac{r_{on-max}}{r_{on-max} + R_G} + \frac{r_{off-max}}{r_{off-max} + R_G} \right)$$

where

- f_{INP} = signal frequency at the control input IN+
 - Q_G = power device gate charge
 - V_{CC2} = positive output supply with respect to GND2
 - V_{EE2} = negative output supply with respect to GND2
 - r_{on-max} = worst case output resistance in the on-state: 4Ω
 - $r_{off-max}$ = worst case output resistance in the off-state: 2.5Ω
 - R_G = gate resistor
- (5)

Once R_G is determined, [Equation 5](#) is to be used to verify whether $P_{OL-WC} < P_{OL}$. [Figure 50](#) shows a simplified output stage model for calculating P_{OL-WC} .

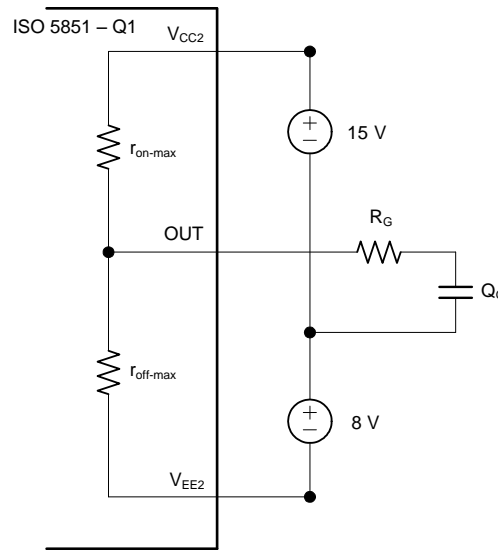

Copyright © 2016, Texas Instruments Incorporated

Figure 50. Simplified Output Model for Calculating P_{OL-wc}

10.2.2.10 Example

This examples considers an IGBT drive with the following parameters:

$$I_{ON-PK} = 2 \text{ A}, Q_G = 650 \text{ nC}, f_{INP} = 20 \text{ kHz}, V_{CC2} = 15 \text{ V}, V_{EE2} = -8 \text{ V} \quad (6)$$

Applying the value of the gate resistor $R_G = 10 \Omega$.

Then, calculating the worst-case output power consumption as a function of R_G , using Equation 5 r_{on-max} = worst case output resistance in the on-state: 4Ω , $r_{off-max}$ = worst case output resistance in the off-state: 2.5Ω , R_G = gate resistor yields

$$P_{OL-WC} = 0.5 \times 20 \text{ kHz} \times 650 \text{ nC} \times (15 \text{ V} - (-8 \text{ V})) \times \left(\frac{4 \Omega}{4 \Omega + 10 \Omega} + \frac{2.5 \Omega}{2.5 \Omega + 10 \Omega} \right) = 72.61 \text{ mW} \quad (7)$$

Because $P_{OL-WC} = 72.61 \text{ mW}$ is below the calculated maximum of $P_{OL} = 88.25 \text{ mW}$, the resistor value of $R_G = 10 \Omega$ is suitable for this application.

10.2.2.11 Higher Output Current Using an External Current Buffer

To increase the IGBT gate drive current, a non-inverting current buffer (such as the npn/pnp buffer shown in Figure 51) may be used. Inverting types are not compatible with the desaturation fault protection circuitry and must be avoided. The MJD44H11/MJD45H11 pair is appropriate for currents up to 8 A, the D44VH10/ D45VH10 pair for up to 15 A maximum.

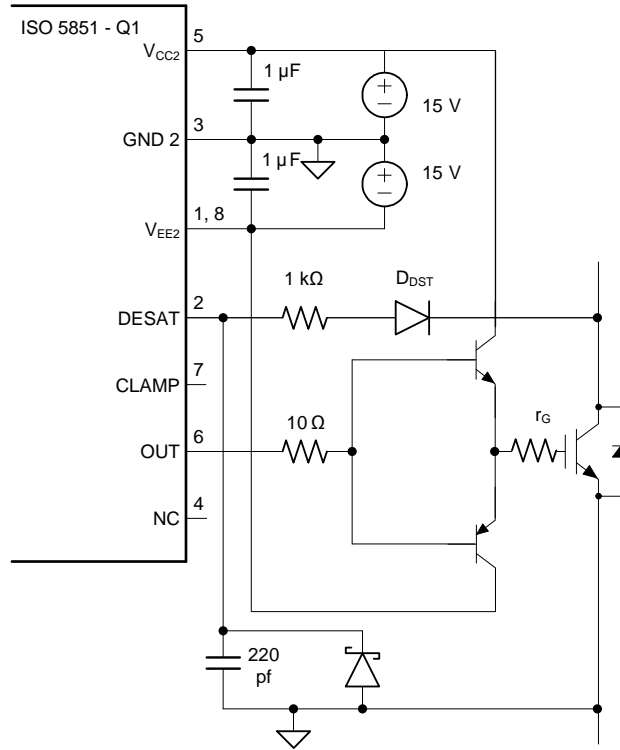

Copyright © 2016, Texas Instruments Incorporated

Figure 51. Current Buffer for Increased Drive Current

10.2.3 Application Curve

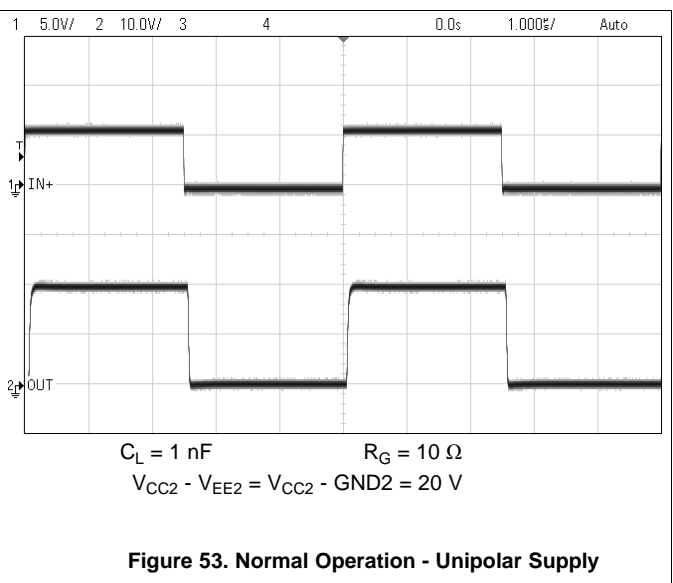
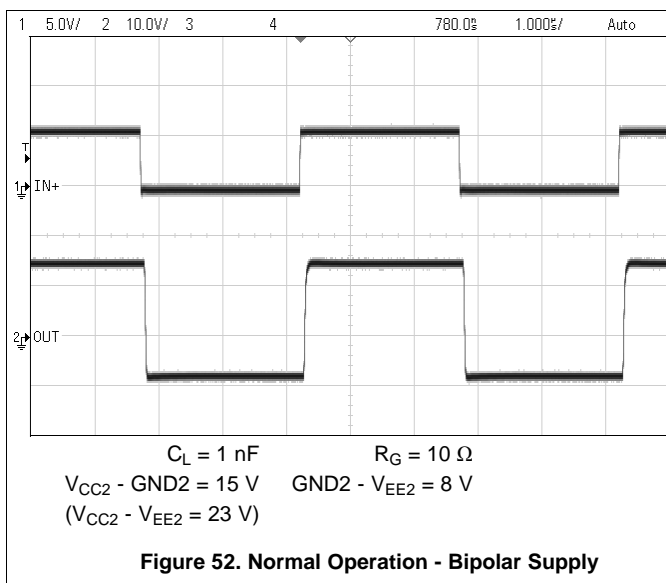

11 Power Supply Recommendations

To ensure reliable operation at all data rates and supply voltages, a 0.1- μ F bypass capacitor is recommended at input supply pin V_{CC1} and 1- μ F bypass capacitor is recommended at output supply pin V_{CC2} . The capacitors should be placed as close to the supply pins as possible. Recommended placement of capacitors needs to be 2-mm maximum from input and output power supply pin (V_{CC1} and V_{CC2}).

12 Layout

12.1 Layout Guidelines

A minimum of four layers is required to accomplish a low EMI PCB design (see [Figure 54](#)). Layer stacking should be in the following order (top-to-bottom): high-current or sensitive signal layer, ground plane, power plane and low-frequency signal layer.

- Routing the high-current or sensitive traces on the top layer avoids the use of vias (and the introduction of their inductances) and allows for clean interconnects between the gate driver and the microcontroller and power transistors. Gate driver control input, Gate driver output OUT and DESAT should be routed in the top layer.
- Placing a solid ground plane next to the sensitive signal layer provides an excellent low-inductance path for the return current flow. On the driver side, use GND2 as the ground plane.
- Placing the power plane next to the ground plane creates additional high-frequency bypass capacitance of approximately 100 pF/inch². On the gate-driver V_{EE2} and V_{CC2} can be used as power planes. They can share the same layer on the PCB as long as they are not connected together.
- Routing the slower speed control signals on the bottom layer allows for greater flexibility as these signal links usually have margin to tolerate discontinuities such as vias.

For more detailed layout recommendations, including placement of capacitors, impact of vias, reference planes, routing etc. see Application Note [SLLA284](#), *Digital Isolator Design Guide*.

12.2 PCB Material

For digital circuit boards operating at less than 150 Mbps, (or rise and fall times greater than 1 ns), and trace lengths of up to 10 inches, use standard FR-4 UL94V-0 printed circuit board. This PCB is preferred over cheaper alternatives because of lower dielectric losses at high frequencies, less moisture absorption, greater strength and stiffness, and the self-extinguishing flammability-characteristics.

12.3 Layout Example

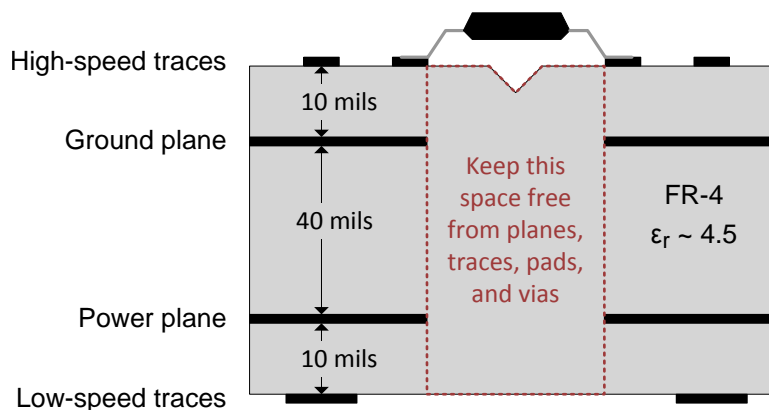

Figure 54. Recommended Layer Stack

13 器件和文档支持

13.1 文档支持

13.1.1 相关文档

相关文档如下：

- 《ISO5851 评估模块 (EVM) 用户指南》， [SLLU218](#)
- 《数字隔离器设计指南》， [SLLA284](#)
- 《隔离相关术语》， [SLLA353](#)

13.2 接收文档更新通知

要接收文档更新通知，请访问 www.ti.com.cn 您器件对应的产品文件夹。点击右上角的提醒我 (Alert me) 注册后，即可每周定期收到已更改的产品信息。有关更改的详细信息，请查阅已修订文档的修订历史记录。

13.3 社区资源

The following links connect to TI community resources. Linked contents are provided "AS IS" by the respective contributors. They do not constitute TI specifications and do not necessarily reflect TI's views; see TI's [Terms of Use](#).

TI E2E™ Online Community *TI's Engineer-to-Engineer (E2E) Community*. Created to foster collaboration among engineers. At e2e.ti.com, you can ask questions, share knowledge, explore ideas and help solve problems with fellow engineers.

Design Support *TI's Design Support* Quickly find helpful E2E forums along with design support tools and contact information for technical support.

13.4 商标

E2E is a trademark of Texas Instruments.

All other trademarks are the property of their respective owners.

13.5 静电放电警告



这些装置包含有限的内置 ESD 保护。存储或装卸时，应将导线一起截短或将装置放置于导电泡棉中，以防止 MOS 门极遭受静电损伤。

13.6 Glossary

[SLYZ022](#) — *TI Glossary*.

This glossary lists and explains terms, acronyms, and definitions.

14 机械、封装和可订购信息

以下页中包括机械、封装和可订购信息。这些信息是针对指定器件可提供的最新数据。这些数据会在无通知且不对本文档进行修订的情况下发生改变。欲获得该数据表的浏览器版本，请查阅左侧的导航栏。

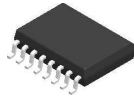
PACKAGE OUTLINE

DW0016B
SOIC - 2.65 mm max height

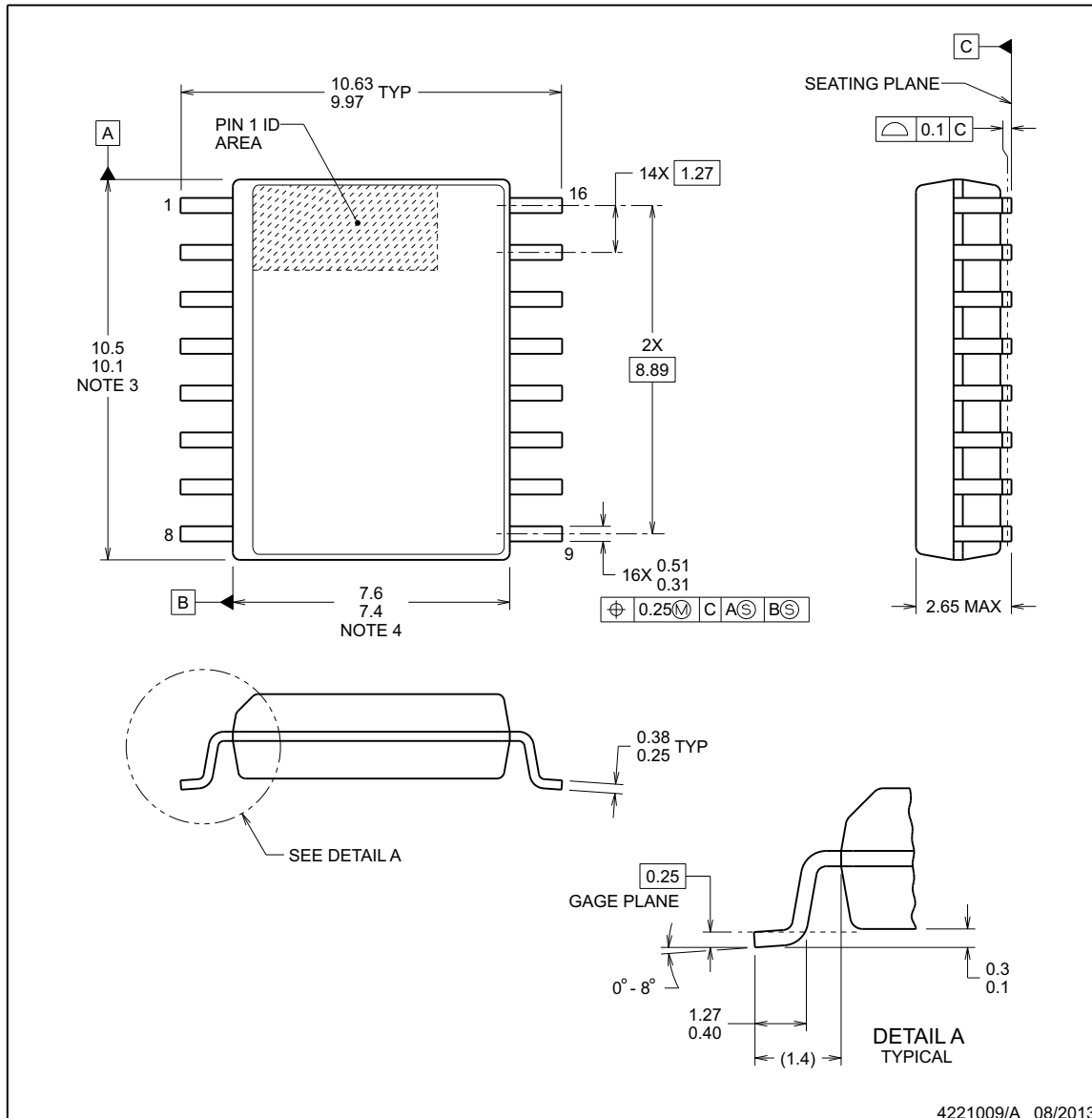
SOIC

NOTES:

1. All linear dimensions are in millimeters. Dimensions in parenthesis are for reference only. Dimensioning and tolerancing per ASME Y14.5M.
2. This drawing is subject to change without notice.
3. This dimension does not include mold flash, protrusions, or gate burrs. Mold flash, protrusions, or gate burrs shall not exceed 0.15 mm, per side.
4. This dimension does not include interlead flash. Interlead flash shall not exceed 0.25 mm, per side.
5. Reference JEDEC registration MO-013, variation AA.

EXAMPLE BOARD LAYOUT

DW0016B

SOIC - 2.65 mm max height

SOIC

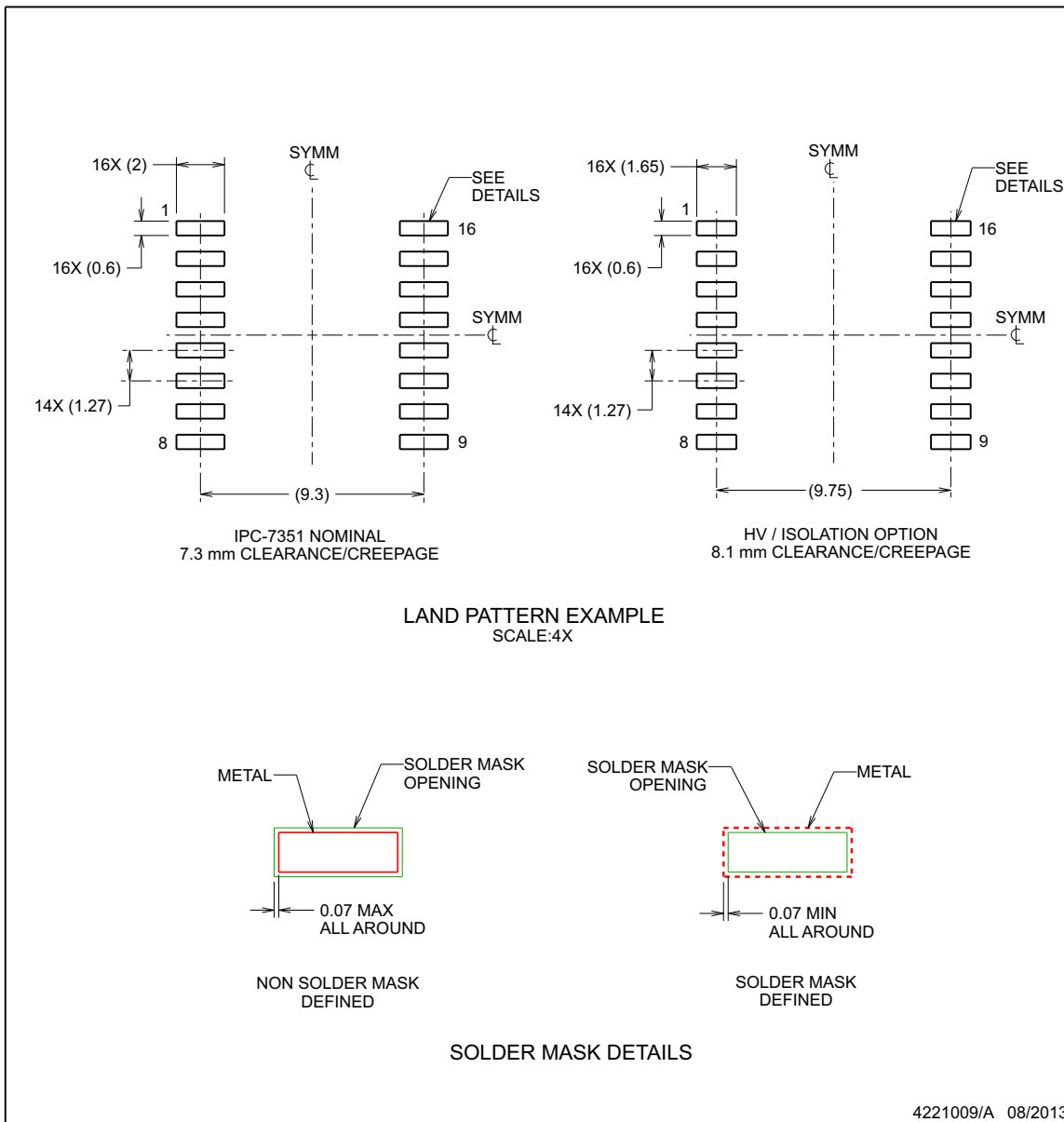

NOTES: (continued)

- 6. Publication IPC-7351 may have alternate designs.
- 7. Solder mask tolerances between and around signal pads can vary based on board fabrication site.

EXAMPLE STENCIL DESIGN

DW0016B

SOIC - 2.65 mm max height

SOIC

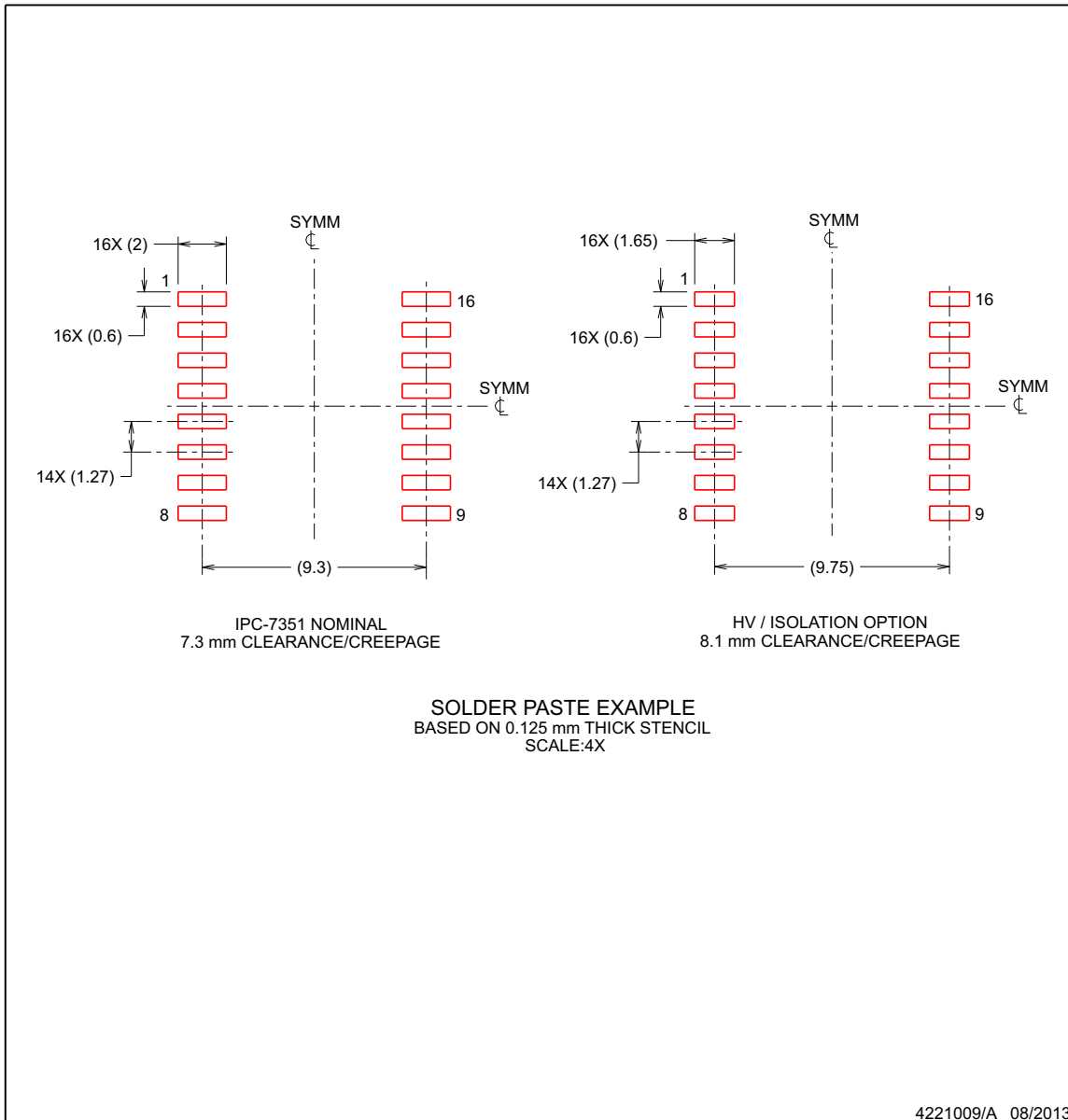

NOTES: (continued)

- 8. Laser cutting apertures with trapezoidal walls and rounded corners may offer better paste release. IPC-7525 may have alternate design recommendations.
- 9. Board assembly site may have different recommendations for stencil design.

PACKAGING INFORMATION

Orderable part number	Status (1)	Material type (2)	Package Pins	Package qty Carrier	RoHS (3)	Lead finish/ Ball material (4)	MSL rating/ Peak reflow (5)	Op temp (°C)	Part marking (6)
ISO5851QDWQ1	Obsolete	Production	SOIC (DW) 16	-	-	Call TI	Call TI	-40 to 125	ISO5851Q
ISO5851QDWRQ1	Active	Production	SOIC (DW) 16	2000 LARGE T&R	Yes	NIPDAU	Level-2-260C-1 YEAR	-40 to 125	ISO5851Q
ISO5851QDWRQ1.A	Active	Production	SOIC (DW) 16	2000 LARGE T&R	Yes	NIPDAU	Level-2-260C-1 YEAR	-40 to 125	ISO5851Q
ISO5851QDWRQ1.B	Active	Production	SOIC (DW) 16	2000 LARGE T&R	Yes	NIPDAU	Level-2-260C-1 YEAR	-40 to 125	ISO5851Q

(1) **Status:** For more details on status, see our [product life cycle](#).

(2) **Material type:** When designated, preproduction parts are prototypes/experimental devices, and are not yet approved or released for full production. Testing and final process, including without limitation quality assurance, reliability performance testing, and/or process qualification, may not yet be complete, and this item is subject to further changes or possible discontinuation. If available for ordering, purchases will be subject to an additional waiver at checkout, and are intended for early internal evaluation purposes only. These items are sold without warranties of any kind.

(3) **RoHS values:** Yes, No, RoHS Exempt. See the [TI RoHS Statement](#) for additional information and value definition.

(4) **Lead finish/Ball material:** Parts may have multiple material finish options. Finish options are separated by a vertical ruled line. Lead finish/Ball material values may wrap to two lines if the finish value exceeds the maximum column width.

(5) **MSL rating/Peak reflow:** The moisture sensitivity level ratings and peak solder (reflow) temperatures. In the event that a part has multiple moisture sensitivity ratings, only the lowest level per JEDEC standards is shown. Refer to the shipping label for the actual reflow temperature that will be used to mount the part to the printed circuit board.

(6) **Part marking:** There may be an additional marking, which relates to the logo, the lot trace code information, or the environmental category of the part.

Multiple part markings will be inside parentheses. Only one part marking contained in parentheses and separated by a "~" will appear on a part. If a line is indented then it is a continuation of the previous line and the two combined represent the entire part marking for that device.

Important Information and Disclaimer: The information provided on this page represents TI's knowledge and belief as of the date that it is provided. TI bases its knowledge and belief on information provided by third parties, and makes no representation or warranty as to the accuracy of such information. Efforts are underway to better integrate information from third parties. TI has taken and continues to take reasonable steps to provide representative and accurate information but may not have conducted destructive testing or chemical analysis on incoming materials and chemicals. TI and TI suppliers consider certain information to be proprietary, and thus CAS numbers and other limited information may not be available for release.

In no event shall TI's liability arising out of such information exceed the total purchase price of the TI part(s) at issue in this document sold by TI to Customer on an annual basis.

OTHER QUALIFIED VERSIONS OF ISO5851-Q1 :

- Catalog : [ISO5851](#)

NOTE: Qualified Version Definitions:

- Catalog - TI's standard catalog product

重要通知和免责声明

TI“按原样”提供技术和可靠性数据（包括数据表）、设计资源（包括参考设计）、应用或其他设计建议、网络工具、安全信息和其他资源，不保证没有瑕疵且不做任何明示或暗示的担保，包括但不限于对适销性、某特定用途方面的适用性或不侵犯任何第三方知识产权的暗示担保。

这些资源可供使用 TI 产品进行设计的熟练开发人员使用。您将自行承担以下全部责任：(1) 针对您的应用选择合适的 TI 产品，(2) 设计、验证并测试您的应用，(3) 确保您的应用满足相应标准以及任何其他功能安全、信息安全、监管或其他要求。

这些资源如有变更，恕不另行通知。TI 授权您仅可将这些资源用于研发本资源所述的 TI 产品的相关应用。严禁以其他方式对这些资源进行复制或展示。您无权使用任何其他 TI 知识产权或任何第三方知识产权。您应全额赔偿因在这些资源的使用中对 TI 及其代表造成的任何索赔、损害、成本、损失和债务，TI 对此概不负责。

TI 提供的产品受 [TI 的销售条款](#) 或 [ti.com](#) 上其他适用条款/TI 产品随附的其他适用条款的约束。TI 提供这些资源并不会扩展或以其他方式更改 TI 针对 TI 产品发布的适用的担保或担保免责声明。

TI 反对并拒绝您可能提出的任何其他或不同的条款。

邮寄地址：Texas Instruments, Post Office Box 655303, Dallas, Texas 75265
版权所有 © 2025，德州仪器 (TI) 公司