

# 具有内部电流感测功能的 DRV8871 3.6A 刷式直流电机驱动器 (PWM 控制)

## 1 特性

- H 桥电机驱动器
  - 驱动一个直流电机、一个步进电机的绕组或其他负载
- 6.5V 至 45V 宽工作电压范围
- 565mΩ (典型值)  $R_{DS(on)}$  (HS + LS)
- 3.6A 峰值电流驱动能力
- PWM 控制接口
- 无需感测电阻即可实现电流调节
- 低功耗休眠模式
- 小型封装尺寸
  - 8 引脚 HSOP 封装, 带有 PowerPAD™
  - 4.9mm × 6mm
- 集成保护 特性
  - VM 欠压闭锁 (UVLO)
  - 过流保护 (OCP)
  - 热关断 (TSD)
  - 自动故障恢复

## 2 应用

- 打印机
- 电器
- 工业设备
- 其他机电 应用

简化电路原理图

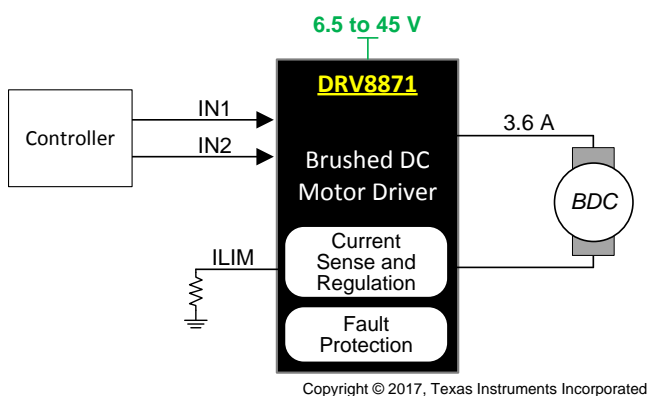

## 3 说明

DRV8871 器件是一款刷式直流电机驱动器, 适用于打印机、电器、工业设备以及其他小型机器。两个逻辑输入控制 H 桥驱动器, 该驱动器由四个 N 沟道金属氧化物半导体场效应晶体管 (MOSFET) 组成, 能够以高达 3.6A 的峰值电流双向控制电机。利用电流衰减模式, 可通过对输入进行脉宽调制 (PWM) 来控制电机转速。如果将两个输入均置为低电平, 则电机驱动器将进入低功耗休眠模式。

DRV8871 器件具有高级电流调节电路, 该电路不使用模拟电压基准或外部感应电阻器。这种新型解决方案采用标准的低成本、低功耗电阻来设置电流阈值。该器件能够将电流限制在某一已知水平, 这可显著降低系统功耗要求, 并且无需大容量电容来维持稳定电压, 尤其是在电机启动和停转时。

该器件针对故障和短路问题提供了全面保护, 包括欠压锁定 (UVLO)、过流保护 (OCP) 和过热保护 (TSD)。故障排除后, 器件会自动恢复正常工作。

器件信息 (1)

部件号	封装	封装尺寸 (标称值)
DRV8871	HSOP (8)	4.90mm × 6.00mm

(1) 要了解所有可用封装, 请参见数据表末尾的可订购产品附录。

峰值电流调节

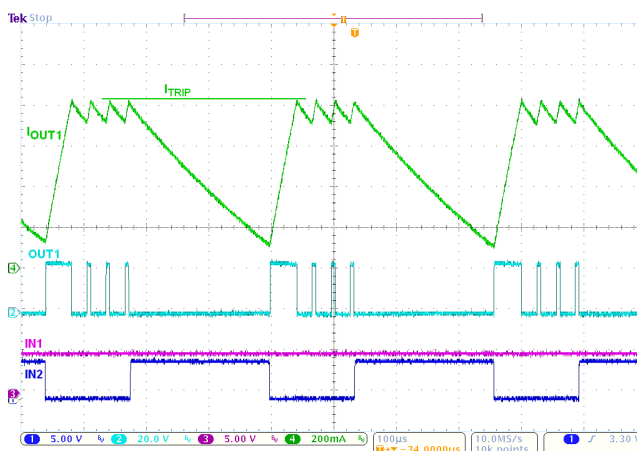

## 目录

<b>1</b>	特性 .....	<b>1</b>	<b>8</b>	<b>Application and Implementation</b> .....	<b>11</b>
<b>2</b>	应用 .....	<b>1</b>	8.1	Application Information.....	11
<b>3</b>	说明 .....	<b>1</b>	8.2	Typical Application .....	11
<b>4</b>	修订历史记录 .....	<b>2</b>	<b>9</b>	<b>Power Supply Recommendations</b> .....	<b>14</b>
<b>5</b>	<b>Pin Configuration and Functions</b> .....	<b>3</b>	9.1	Bulk Capacitance .....	14
<b>6</b>	<b>Specifications</b> .....	<b>3</b>	<b>10</b>	<b>Layout</b> .....	<b>15</b>
6.1	Absolute Maximum Ratings .....	3	10.1	Layout Guidelines .....	15
6.2	ESD Ratings.....	3	10.2	Layout Example .....	15
6.3	Recommended Operating Conditions.....	4	10.3	Thermal Considerations .....	15
6.4	Thermal Information .....	4	10.4	Power Dissipation .....	15
6.5	Electrical Characteristics.....	5	<b>11</b>	<b>器件和文档支持</b> .....	<b>17</b>
6.6	Typical Characteristics .....	6	11.1	文档支持 .....	17
<b>7</b>	<b>Detailed Description</b> .....	<b>7</b>	11.2	接收文档更新通知 .....	17
7.1	Overview .....	7	11.3	社区资源 .....	17
7.2	Functional Block Diagram .....	7	11.4	商标 .....	17
7.3	Feature Description.....	8	11.5	静电放电警告 .....	17
7.4	Device Functional Modes.....	10	11.6	Glossary .....	17
			<b>12</b>	<b>机械、封装和可订购信息</b> .....	<b>17</b>

## 4 修订历史记录

注：之前版本的页码可能与当前版本有所不同。

<b>Changes from Revision A (January 2016) to Revision B</b>	<b>Page</b>
• Deleted the power supply voltage ramp rate (VM) parameter from the <i>Absolute Maximum Ratings</i> table .....	3
• Added the output current parameter to the <i>Absolute Maximum Ratings</i> table .....	3
• 已添加 接收文档更新通知 部分 .....	17

<b>Changes from Original (August 2015) to Revision A</b>	<b>Page</b>
• Updated the $f_{PWM}$ max value and added a note .....	4
• Removed the redundant $T_A$ condition and added $f_{PWM} = 24$ kHz .....	5
• Added more information to clarify how the max RMS current varies for different applications .....	12

## 5 Pin Configuration and Functions

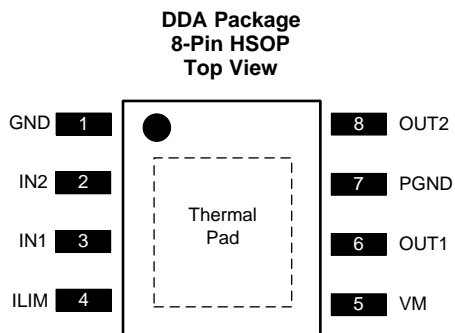

### Pin Functions

PIN		TYPE	DESCRIPTION	
NAME	NO.			
GND	1	PWR	Logic ground	Connect to board ground
ILIM	4	I	Current limit control	Connect a resistor to ground to set the current chopping threshold
IN1	3	I	Logic inputs	Controls the H-bridge output. Has internal pulldowns (see <a href="#">Table 1</a> ).
IN2	2			
OUT1	6	O	H-bridge output	Connect directly to the motor or other inductive load.
OUT2	8			
PGND	7	PWR	High-current ground path	Connect to board ground.
VM	5	PWR	6.5-V to 45-V power supply	Connect a 0.1- $\mu$ F bypass capacitor to ground, as well as sufficient bulk capacitance, rated for the VM voltage.
PAD	—	—	Thermal pad	Connect to board ground. For good thermal dissipation, use large ground planes on multiple layers, and multiple nearby vias connecting those planes.

## 6 Specifications

### 6.1 Absolute Maximum Ratings

over operating free-air temperature range (unless otherwise noted)<sup>(1)</sup>

	MIN	MAX	UNIT
Power supply voltage (VM)	−0.3	50	V
Logic input voltage (IN1, IN2)	−0.3	7	V
Continuous phase node pin voltage (OUT1, OUT2)	−0.7	VM + 0.7	V
Output current (100% duty cycle)	0	3.5	A
Operating junction temperature, T <sub>J</sub>	−40	150	°C
Storage temperature, T <sub>stg</sub>	−65	150	°C

(1) Stresses beyond those listed under *Absolute Maximum Ratings* may cause permanent damage to the device. These are stress ratings only, which do not imply functional operation of the device at these or any other conditions beyond those indicated under *Recommended Operating Conditions*. Exposure to absolute-maximum-rated conditions for extended periods may affect device reliability.

### 6.2 ESD Ratings

		VALUE	UNIT
V <sub>(ESD)</sub>	Electrostatic discharge	Human-body model (HBM), per ANSI/ESDA/JEDEC JS-001 <sup>(1)</sup>	±6000
		Charged-device model (CDM), per JEDEC specification JESD22-C101 <sup>(2)</sup>	±750

(1) JEDEC document JEP155 states that 500-V HBM allows safe manufacturing with a standard ESD control process.

(2) JEDEC document JEP157 states that 250-V CDM allows safe manufacturing with a standard ESD control process.

### 6.3 Recommended Operating Conditions

over operating free-air temperature range (unless otherwise noted)

		MIN	MAX	UNIT
V <sub>M</sub>	Power supply voltage	6.5	45	V
V <sub>I</sub>	Logic input voltage (IN1, IN2)	0	5.5	V
f <sub>PWM</sub>	Logic input PWM frequency (IN1, IN2)	0	200 <sup>(1)</sup>	kHz
I <sub>peak</sub>	Peak output current <sup>(2)</sup>	0	3.6	A
T <sub>A</sub>	Operating ambient temperature <sup>(2)</sup>	–40	125	°C

(1) The voltages applied to the inputs should have at least 800 ns of pulse width to ensure detection. Typical devices require at least 400 ns. If the PWM frequency is 200 kHz, the usable duty cycle range is 16% to 84%.

(2) Power dissipation and thermal limits must be observed

### 6.4 Thermal Information

THERMAL METRIC <sup>(1)</sup>		DRV8871	UNIT
		DDA (HSOP)	
		8 PINS	
R <sub>θJA</sub>	Junction-to-ambient thermal resistance	41.1	°C/W
R <sub>θJC(top)</sub>	Junction-to-case (top) thermal resistance	53.1	°C/W
R <sub>θJB</sub>	Junction-to-board thermal resistance	23.1	°C/W
ψ <sub>JT</sub>	Junction-to-top characterization parameter	8.2	°C/W
ψ <sub>JB</sub>	Junction-to-board characterization parameter	23	°C/W
R <sub>θJC(bot)</sub>	Junction-to-case (bottom) thermal resistance	2.7	°C/W

(1) For more information about traditional and new thermal metrics, see the [Semiconductor and IC Package Thermal Metrics](#) application report (SPRA953).

## 6.5 Electrical Characteristics

 $T_A = 25^\circ\text{C}$ , over recommended operating conditions (unless otherwise noted)

PARAMETER		TEST CONDITIONS	MIN	TYP	MAX	UNIT
<b>POWER SUPPLY (VM)</b>						
VM	VM operating voltage		6.5		45	V
$I_{VM}$	VM operating supply current	VM = 12 V		3	10	mA
$I_{VMSLEEP}$	VM sleep current	VM = 12 V			10	$\mu\text{A}$
$t_{ON}^{(1)}$	Turn-on time	VM > $V_{UVLO}$ with IN1 or IN2 high		40	50	$\mu\text{s}$
<b>LOGIC-LEVEL INPUTS (IN1, IN2)</b>						
$V_{IL}$	Input logic low voltage				0.5	V
$V_{IH}$	Input logic high voltage		1.5			V
$V_{HYS}$	Input logic hysteresis			0.5		V
$I_{IL}$	Input logic low current	$V_{IN} = 0\text{ V}$	-1		1	$\mu\text{A}$
$I_{IH}$	Input logic high current	$V_{IN} = 3.3\text{ V}$		33	100	$\mu\text{A}$
$R_{PD}$	Pulldown resistance	To GND		100		k $\Omega$
$t_{PD}$	Propagation delay	INx to OUTx change (see <a href="#">Figure 6</a> )		0.7	1	$\mu\text{s}$
$t_{sleep}$	Time to sleep	Inputs low to sleep		1	1.5	ms
<b>MOTOR DRIVER OUTPUTS (OUT1, OUT2)</b>						
$R_{DS(ON)}$	High-side FET on resistance	VM = 24 V, I = 1 A, $f_{PWM} = 25\text{ kHz}$		307	360	m $\Omega$
$R_{DS(ON)}$	Low-side FET on resistance	VM = 24 V, I = 1 A, $f_{PWM} = 25\text{ kHz}$		258	320	m $\Omega$
$t_{DEAD}$	Output dead time			220		ns
$V_d$	Body diode forward voltage	$I_{OUT} = 1\text{ A}$		0.8	1	V
<b>CURRENT REGULATION</b>						
$V_{ILIM}$	Constant for calculating current regulation (see <a href="#">Equation 1</a> )	$I_{OUT} = 1\text{ A}$	59	64	69	kV
$t_{OFF}$	PWM off-time			25		$\mu\text{s}$
$t_{BLANK}$	PWM blanking time			2		$\mu\text{s}$
<b>PROTECTION CIRCUITS</b>						
$V_{UVLO}$	VM undervoltage lockout	VM falls until UVLO triggers		6.1	6.4	V
		VM rises until operation recovers		6.3	6.5	
$V_{UV,HYS}$	VM undervoltage hysteresis	Rising to falling threshold	100	180		mV
$I_{OCP}$	Overcurrent protection trip level		3.7	4.5	6.4	A
$t_{OCP}$	Overcurrent deglitch time			1.5		$\mu\text{s}$
$t_{RETRY}$	Overcurrent retry time			3		ms
$T_{SD}$	Thermal shutdown temperature		150	175		$^\circ\text{C}$
$T_{HYS}$	Thermal shutdown hysteresis			40		$^\circ\text{C}$

(1)  $t_{ON}$  applies when the device initially powers up, and when it exits sleep mode.

### 6.6 Typical Characteristics

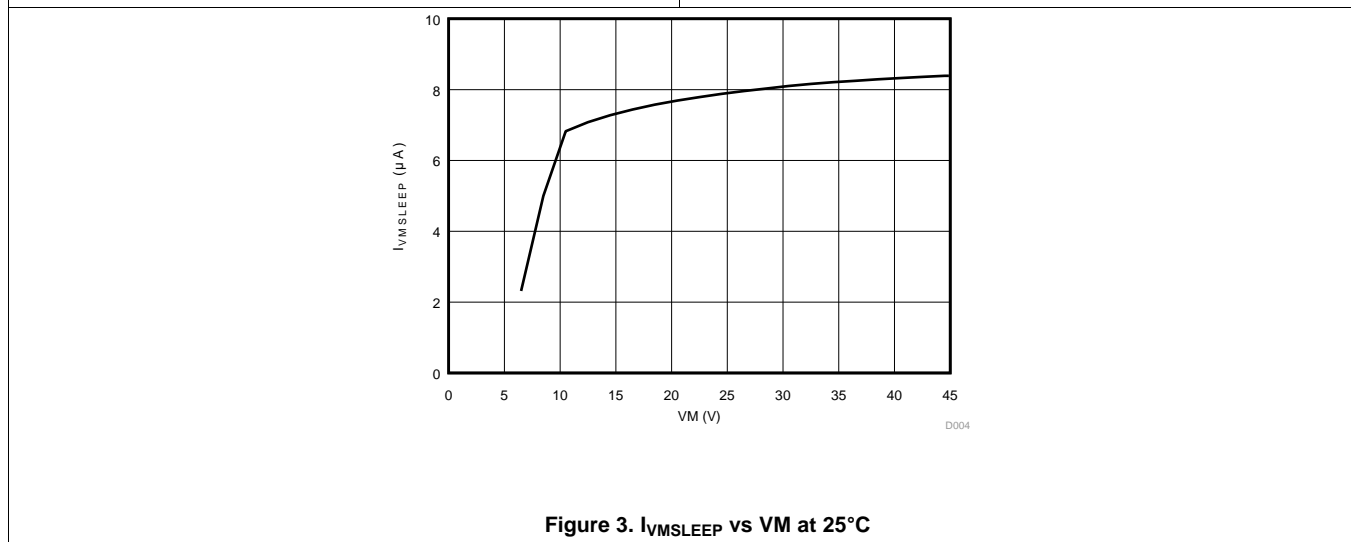
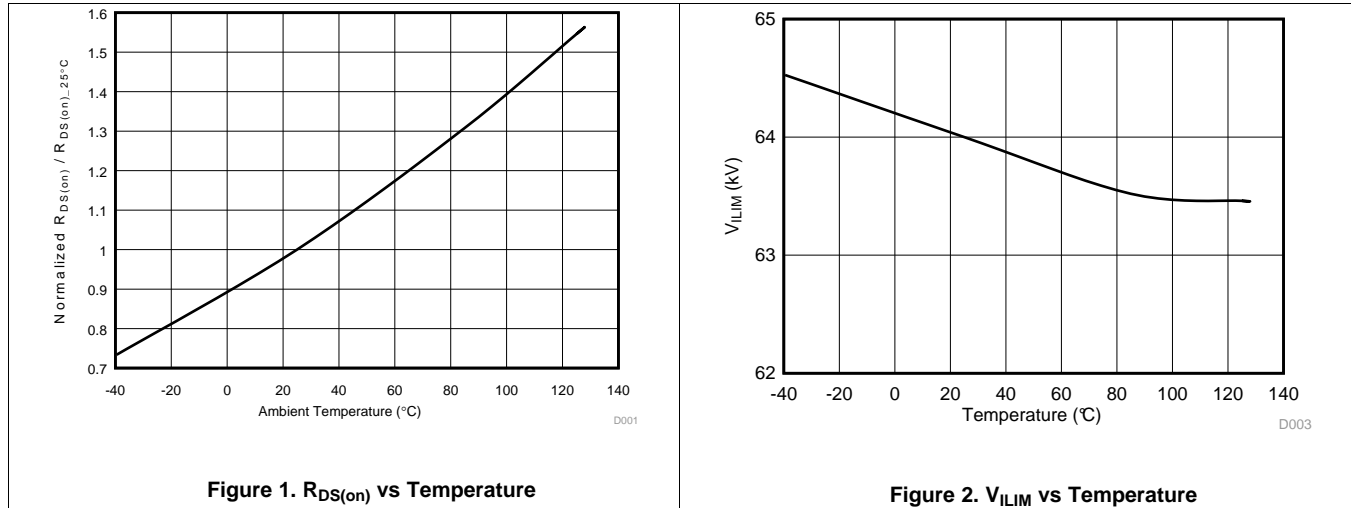

## 7 Detailed Description

### 7.1 Overview

The DRV8871 device is an optimized 8-pin device for driving brushed DC motors with 6.5 to 45 V and up to 3.6-A peak current. The integrated current regulation restricts motor current to a predefined maximum. Two logic inputs control the H-bridge driver, which consists of four N-channel MOSFETs that have a typical  $R_{ds(on)}$  of 565 m $\Omega$  (including one high-side and one low-side FET). A single power input, VM, serves as both device power and the motor winding bias voltage. The integrated charge pump of the device boosts VM internally and fully enhances the high-side FETs. Motor speed can be controlled with pulse-width modulation, at frequencies between 0 to 100 kHz. The device has an integrated sleep mode that is entered by bringing both inputs low. An assortment of protection features prevent the device from being damaged if a system fault occurs.

### 7.2 Functional Block Diagram

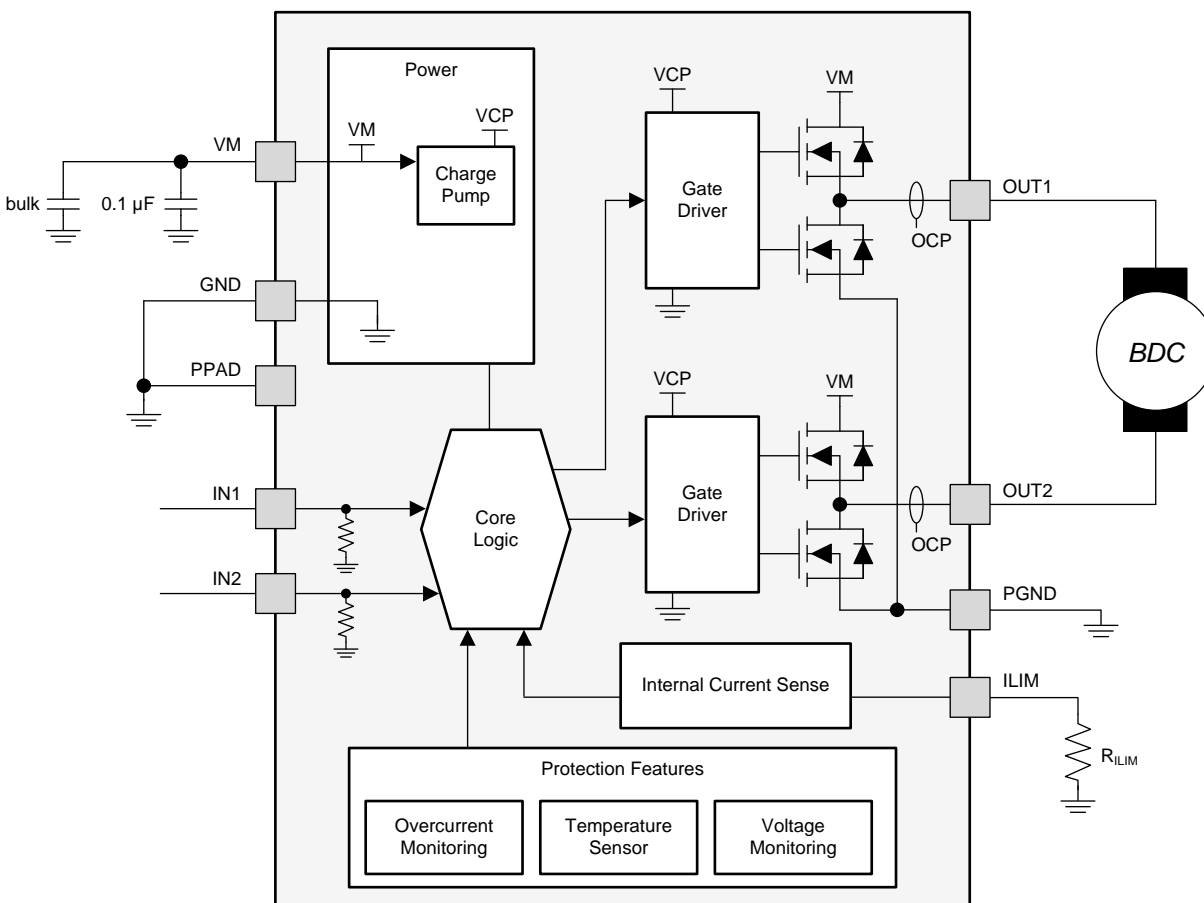

Copyright © 2016, Texas Instruments Incorporated

### 7.3 Feature Description

#### 7.3.1 Bridge Control

The DRV8871 output consists of four N-channel MOSFETs that are designed to drive high current. They are controlled by the two logic inputs IN1 and IN2, according to Table 1.

**Table 1. H-Bridge Control**

IN1	IN2	OUT1	OUT2	DESCRIPTION
0	0	High-Z	High-Z	Coast; H-bridge disabled to High-Z (sleep entered after 1 ms)
0	1	L	H	Reverse (Current OUT2 → OUT1)
1	0	H	L	Forward (Current OUT1 → OUT2)
1	1	L	L	Brake; low-side slow decay

The inputs can be set to static voltages for 100% duty cycle drive, or they can be pulse-width modulated (PWM) for variable motor speed. When using PWM, it typically works best to switch between driving and braking. For example, to drive a motor forward with 50% of its max RPM, IN1 = 1 and IN2 = 0 during the driving period, and IN1 = 1 and IN2 = 1 during the other period. Alternatively, the coast mode (IN1 = 0, IN2 = 0) for *fast current decay* is also available. The input pins can be powered before VM is applied.



**Figure 4. H-Bridge Current Paths**

#### 7.3.2 Sleep Mode

When IN1 and IN2 are both low for time  $t_{SLEEP}$  (typically 1 ms), the DRV8871 device enters a low-power sleep mode, where the outputs remain High-Z and the device uses  $I_{VMSLEEP}$  (microamps) of current. If the device is powered up while both inputs are low, sleep mode is immediately entered. After IN1 or IN2 are high for at least 5  $\mu s$ , the device will be operational 50  $\mu s$  ( $t_{ON}$ ) later.

#### 7.3.3 Current Regulation

The DRV8871 device limits the output current based on a standard resistor attached to pin ILIM, according to this equation:



$$I_{TRIP} (A) = \frac{V_{ILIM} (kV)}{R_{ILIM} (k\Omega)} = \frac{64 (kV)}{R_{ILIM} (k\Omega)} \quad (1)$$

For example, if  $R_{ILIM} = 32 \text{ k}\Omega$ , the DRV8871 device limits motor current to 2 A no matter how much load torque is applied. The minimum allowed  $R_{ILIM}$  is 15 kΩ. System designers should always understand the min and max  $I_{TRIP}$ , based on the  $R_{ILIM}$  resistor component tolerance and the DRV8871 specified  $V_{ILIM}$  range.

When  $I_{TRIP}$  has been reached, the device enforces slow current decay by enabling both low-side FETs, and it does this for time  $t_{OFF}$  (typically 25 μs).

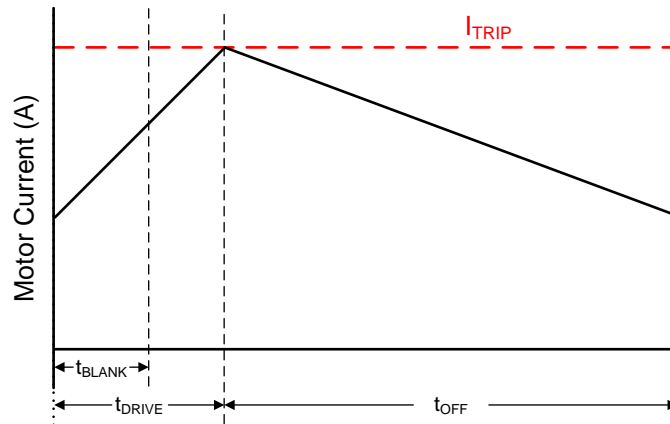

Figure 5. Current Regulation Time Periods

After  $t_{OFF}$  has elapsed, the output is re-enabled according to the two inputs  $INx$ . The drive time ( $t_{DRIVE}$ ) until reaching another  $I_{TRIP}$  event heavily depends on the VM voltage, the motor's back-EMF, and the motor's inductance.

### 7.3.4 Dead Time

When an output changes from driving high to driving low, or driving low to driving high, dead time is automatically inserted to prevent shoot-through.  $t_{DEAD}$  is the time in the middle when the output is High-Z. If the output pin is measured during  $t_{DEAD}$ , the voltage will depend on the direction of current. If current is leaving the pin, the voltage will be a diode drop below ground. If current is entering the pin, the voltage will be a diode drop above VM. This diode is the body diode of the high-side or low-side FET.

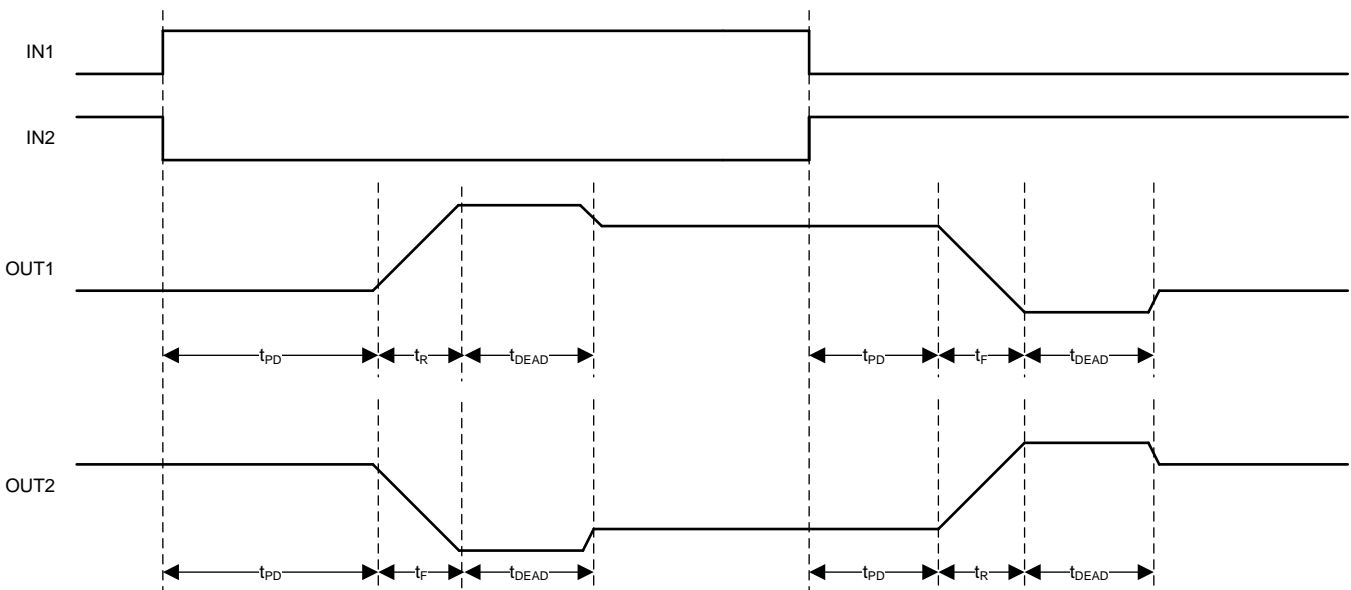

Figure 6. Propagation Delay Time

### 7.3.5 Protection Circuits

The DRV8871 device is fully protected against VM undervoltage, overcurrent, and overtemperature events.

#### 7.3.5.1 VM Undervoltage Lockout (UVLO)

If at any time the voltage on the VM pin falls below the undervoltage lockout threshold voltage, all FETs in the H-bridge will be disabled. Operation will resume when VM rises above the UVLO threshold.

#### 7.3.5.2 Overcurrent Protection (OCP)

If the output current exceeds the OCP threshold  $I_{OCP}$  for longer than  $t_{OCP}$ , all FETs in the H-bridge are disabled for a duration of  $t_{RETRY}$ . After that, the H-bridge will be re-enabled according to the state of the INx pins. If the overcurrent fault is still present, the cycle repeats; otherwise normal device operation resumes.

#### 7.3.5.3 Thermal Shutdown (TSD)

If the die temperature exceeds safe limits, all FETs in the H-bridge will be disabled. After the die temperature has fallen to a safe level, operation automatically resumes.

**Table 2. Protection Functionality**

FAULT	CONDITION	H-BRIDGE STATUS	RECOVERY
VM undervoltage lockout (UVLO)	$VM < V_{UVLO}$	Disabled	$VM > V_{UVLO}$
Overcurrent (OCP)	$I_{OUT} > I_{OCP}$	Disabled	$t_{RETRY}$
Thermal Shutdown (TSD)	$T_J > 150^{\circ}\text{C}$	Disabled	$T_J < T_{SD} - T_{HYS}$

## 7.4 Device Functional Modes

The DRV8871 device can be used in multiple ways to drive a brushed DC motor.

### 7.4.1 PWM With Current Regulation

This scheme uses all of the device capabilities.  $I_{TRIP}$  is set above the normal operating current, and high enough to achieve an adequate spin-up time, but low enough to constrain current to a desired level. Motor speed is controlled by the duty cycle of one of the inputs, while the other input is static. Brake/slow decay is typically used during the off-time.

### 7.4.2 PWM Without Current Regulation

If current regulation is not needed, a 15-k $\Omega$  to 18-k $\Omega$  resistor should be used on pin ILIM. This mode provides the highest possible peak current: up to 3.6 A for a few hundred milliseconds (depending on PCB characteristics and the ambient temperature). If current exceeds 3.6 A, the device might reach overcurrent protection (OCP) or overtemperature shutdown (TSD). If that happens, the device disables and protects itself for about 3 ms ( $t_{RETRY}$ ) and then resumes normal operation.

### 7.4.3 Static Inputs With Current Regulation

IN1 and IN2 can be set high and low for 100% duty cycle drive, and  $I_{TRIP}$  can be used to control the current, speed, and torque capability of the motor.

### 7.4.4 VM Control

In some systems it is desirable to vary VM as a means of changing motor speed. See [Motor Voltage](#) for more information.

## 8 Application and Implementation

### NOTE

Information in the following applications sections is not part of the TI component specification, and TI does not warrant its accuracy or completeness. TI's customers are responsible for determining suitability of components for their purposes. Customers should validate and test their design implementation to confirm system functionality.

### 8.1 Application Information

The DRV8871 device is typically used to drive one brushed DC motor.

### 8.2 Typical Application

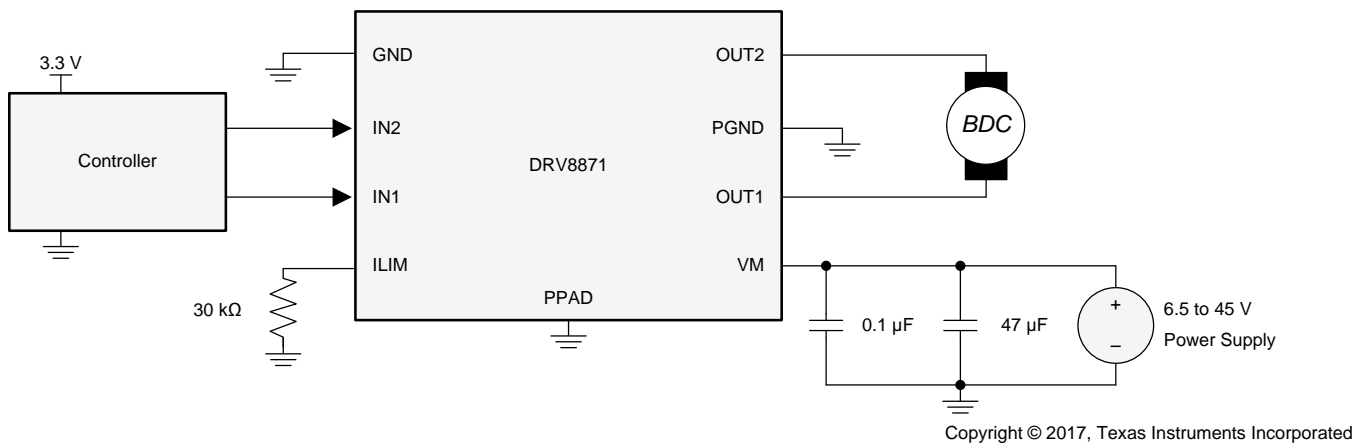

**Figure 7. Typical Connections**

#### 8.2.1 Design Requirements

Table 3 lists the design parameters.

**Table 3. Design Parameters**

DESIGN PARAMETER	REFERENCE	EXAMPLE VALUE
Motor voltage	$V_M$	24 V
Motor RMS current	$I_{RMS}$	0.8 A
Motor startup current	$I_{START}$	2 A
Motor current trip point	$I_{TRIP}$	2.1 A
ILIM resistance	$R_{ILIM}$	30 kΩ
PWM frequency	$f_{PWM}$	5 kHz

#### 8.2.2 Detailed Design Procedure

##### 8.2.2.1 Motor Voltage

The motor voltage to use will depend on the ratings of the motor selected and the desired RPM. A higher voltage spins a brushed DC motor faster with the same PWM duty cycle applied to the power FETs. A higher voltage also increases the rate of current change through the inductive motor windings.

##### 8.2.2.2 Drive Current

The current path is through the high-side sourcing DMOS power driver, motor winding, and low-side sinking DMOS power driver. Power dissipation losses in one source and sink DMOS power driver are shown in the following equation.

$$P_D = I^2 (R_{DS(on)Source} + R_{DS(on)Sink}) \tag{2}$$

The DRV8871 device has been measured to be capable of 2-A RMS current at 25°C on standard FR-4 PCBs. The max RMS current varies based on the PCB design, ambient temperature, and PWM frequency. Typically, switching the inputs at 200 kHz compared to 20 kHz causes 20% more power loss in heat.

### 8.2.3 Application Curves

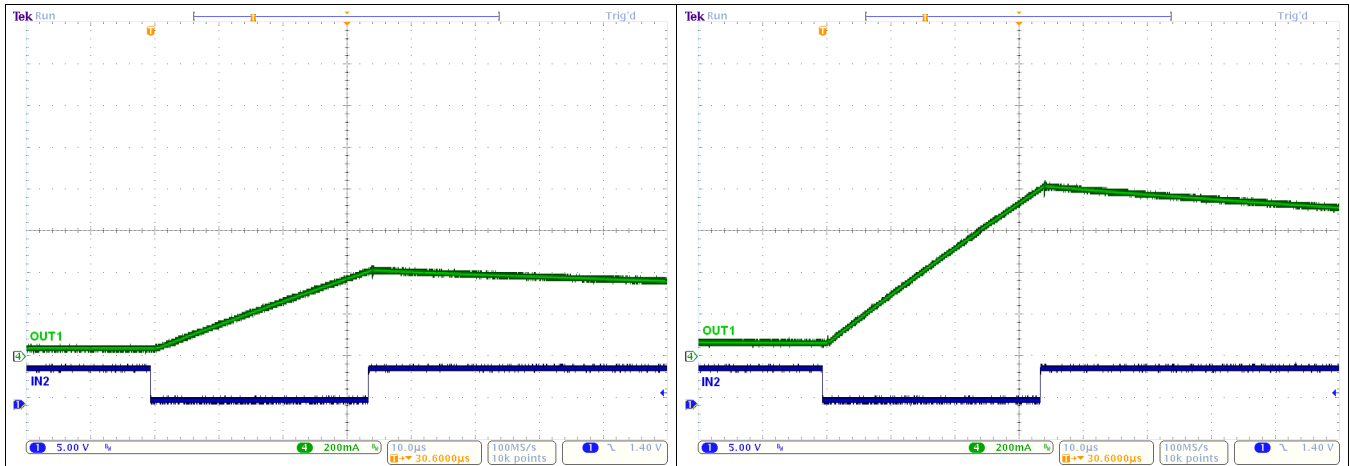

Figure 8. Current Ramp With a 2-Ω, 1 mH, RL Load and VM = 12 V

Figure 9. Current Ramp With a 2-Ω, 1 mH, RL Load and VM = 24 V

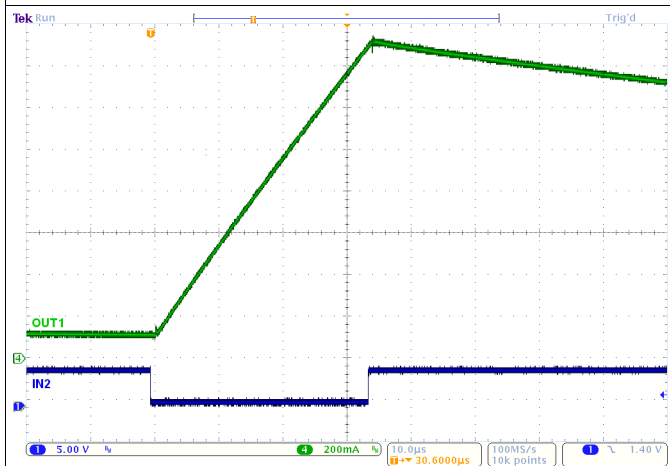

Figure 10. Current Ramp With a 2-Ω, 1 mH, RL Load and VM = 45 V

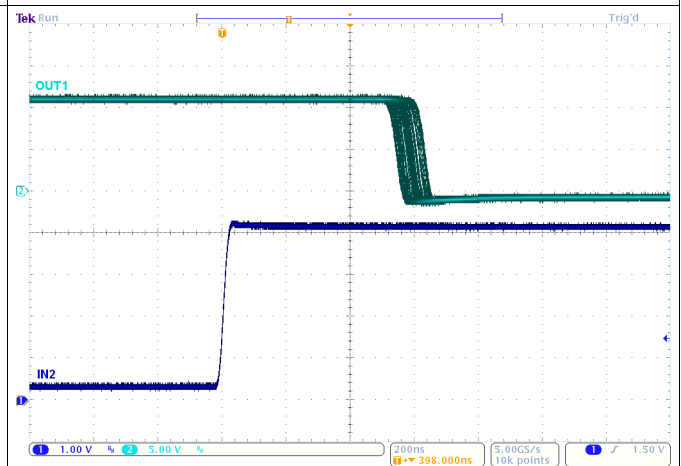
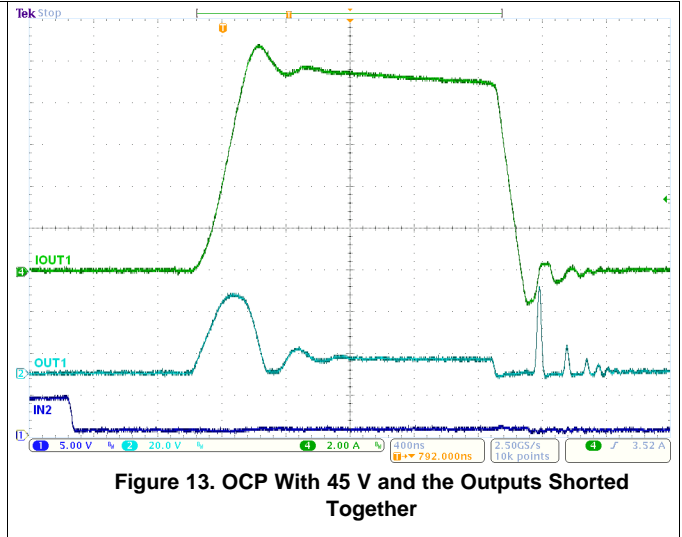
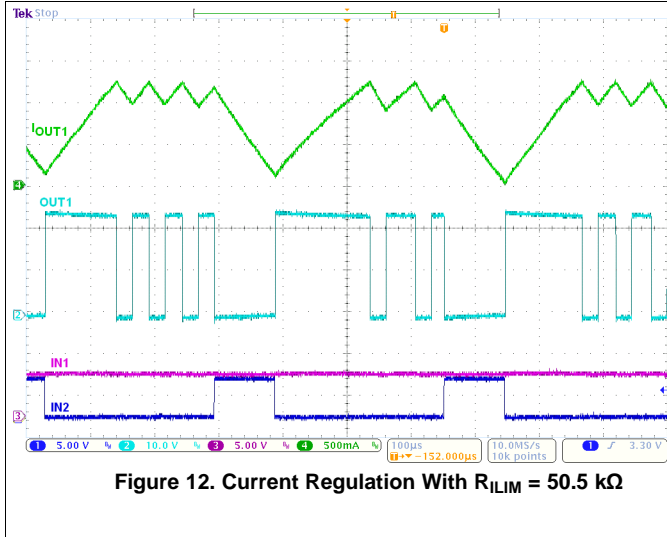

Figure 11.  $t_{PD}$



## 9 Power Supply Recommendations

### 9.1 Bulk Capacitance

Having appropriate local bulk capacitance is an important factor in motor drive system design. In general, having more bulk capacitance is beneficial, while the disadvantages are increased cost and physical size.

The amount of local capacitance needed depends on a variety of factors, including:

- The highest current required by the motor system
- The power supply's capacitance and ability to source current
- The amount of parasitic inductance between the power supply and motor system
- The acceptable voltage ripple
- The type of motor used (brushed DC, brushless DC, stepper)
- The motor braking method

The inductance between the power supply and motor drive system will limit the rate current can change from the power supply. If the local bulk capacitance is too small, the system responds to excessive current demands or dumps from the motor with a change in voltage. When adequate bulk capacitance is used, the motor voltage remains stable and high current can be quickly supplied.

The data sheet generally provides a recommended value, but system-level testing is required to determine the appropriate sized bulk capacitor.

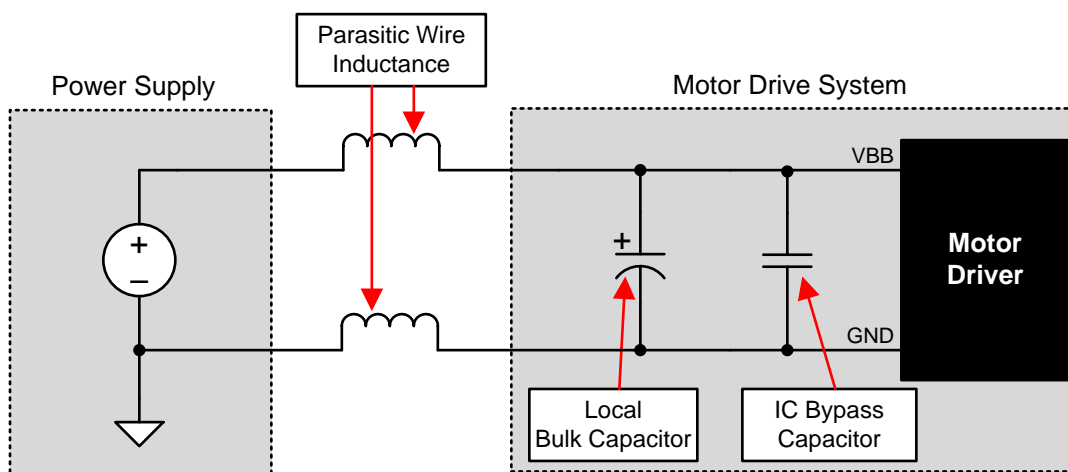

**Figure 14. Example Setup of Motor Drive System With External Power Supply**

The voltage rating for bulk capacitors should be higher than the operating voltage, to provide margin for cases when the motor transfers energy to the supply.

## 10 Layout

### 10.1 Layout Guidelines

The bulk capacitor should be placed to minimize the distance of the high-current path through the motor driver device. The connecting metal trace widths should be as wide as possible, and numerous vias should be used when connecting PCB layers. These practices minimize inductance and allow the bulk capacitor to deliver high current.

Small-value capacitors should be ceramic, and placed closely to device pins.

The high-current device outputs should use wide metal traces.

The device thermal pad should be soldered to the PCB top-layer ground plane. Multiple vias should be used to connect to a large bottom-layer ground plane. The use of large metal planes and multiple vias help dissipate the  $I^2 \times R_{DS(on)}$  heat that is generated in the device.

### 10.2 Layout Example

Recommended layout and component placement is shown in [Figure 15](#)

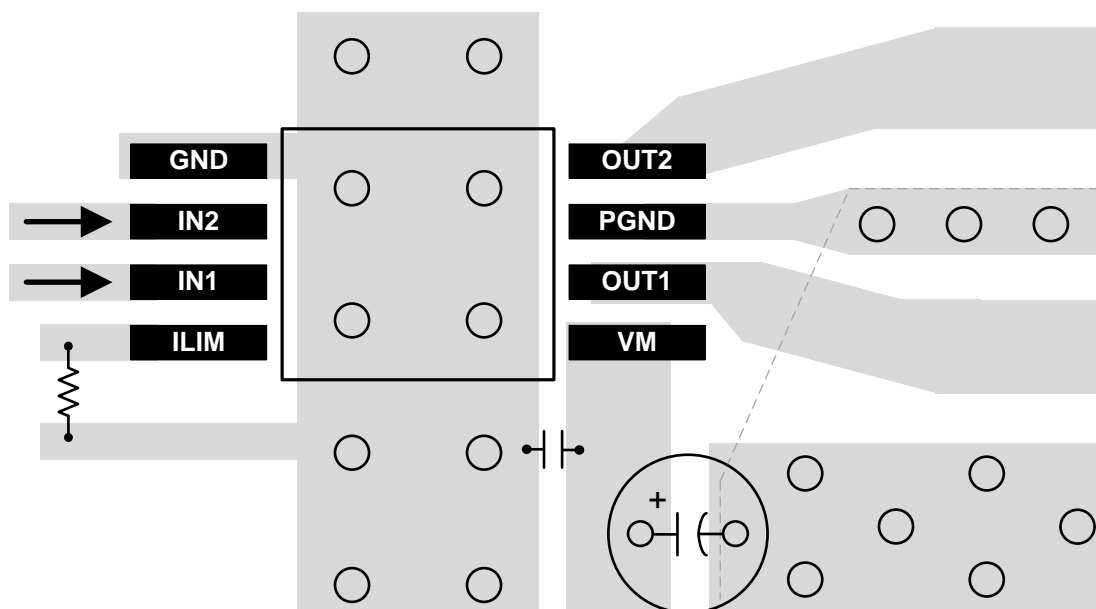

Figure 15. Layout Recommendation

### 10.3 Thermal Considerations

The DRV8871 device has thermal shutdown (TSD) as described in the [Thermal Shutdown \(TSD\)](#) section. If the die temperature exceeds approximately 175°C, the device is disabled until the temperature drops below the temperature hysteresis level.

Any tendency of the device to enter TSD is an indication of either excessive power dissipation, insufficient heatsinking, or too high of an ambient temperature.

### 10.4 Power Dissipation

Power dissipation in the DRV8871 device is dominated by the power dissipated in the output FET resistance,  $R_{DS(on)}$ . Use the equation in the [Drive Current](#) section to calculate the estimated average power dissipation when driving a load.

Note that at startup, the current is much higher than normal running current; this peak current and its duration must be also be considered.

## Power Dissipation (continued)

The maximum amount of power that can be dissipated in the device is dependent on ambient temperature and heatsinking.

### NOTE

$R_{DS(on)}$  increases with temperature, so as the device heats, the power dissipation increases. This fact must be taken into consideration when sizing the heatsink.

The power dissipation of the DRV8871 device is a function of RMS motor current and the FET resistance ( $R_{DS(ON)}$ ) of each output.

$$\text{Power} \approx I_{RMS}^2 \times (\text{High-side } R_{DS(ON)} + \text{Low-side } R_{DS(ON)}) \quad (3)$$

For this example, the ambient temperature is 58°C, and the junction temperature reaches 80°C. At 58°C, the sum of  $R_{DS(ON)}$  is about 0.72 Ω. With an example motor current of 0.8 A, the dissipated power in the form of heat will be  $0.8 \text{ A}^2 \times 0.72 \text{ } \Omega = 0.46 \text{ W}$ .

The temperature that the DRV8871 device reaches depends on the thermal resistance to the air and PCB. It is important to solder the device PowerPAD to the PCB ground plane, with vias to the top and bottom board layers, in order to dissipate heat into the PCB and reduce the device temperature. In the example used here, the DRV8871 device had an effective thermal resistance  $R_{\theta JA}$  of 48°C/W, and:

$$T_J = T_A + (P_D \times R_{\theta JA}) = 58^\circ\text{C} + (0.46 \text{ W} \times 48^\circ\text{C/W}) = 80^\circ\text{C} \quad (4)$$

### 10.4.1 Heatsinking

The PowerPAD package uses an exposed pad to remove heat from the device. For proper operation, this pad must be thermally connected to copper on the PCB to dissipate heat. On a multi-layer PCB with a ground plane, this connection can be accomplished by adding a number of vias to connect the thermal pad to the ground plane.

On PCBs without internal planes, a copper area can be added on either side of the PCB to dissipate heat. If the copper area is on the opposite side of the PCB from the device, thermal vias are used to transfer the heat between top and bottom layers.

For details about how to design the PCB, refer to [PowerPAD™ Thermally Enhanced Package](#) (SLMA002) and [PowerPAD Made Easy™](#) (SLMA004), available at [www.ti.com](http://www.ti.com). In general, the more copper area that can be provided, the more power can be dissipated.



## 11 器件和文档支持

### 11.1 文档支持

#### 11.1.1 相关文档

相关文档如下：

- [电流再循环和衰减模式](#)
- [《计算电机驱动器功耗》](#)
- [《DRV8871 评估模块》](#)
- [《PowerPAD™ 散热增强型封装》](#)
- [《PowerPAD™ 速成》](#)
- [了解电机驱动器电流额定值](#)

#### 11.2 接收文档更新通知

如需接收文档更新通知，请访问 [www.ti.com.cn](http://www.ti.com.cn) 网站上的器件产品文件夹。点击右上角的提醒我 (Alert me) 注册后，即可每周定期收到已更改的产品信息。有关更改的详细信息，请查阅已修订文档中包含的修订历史记录。

#### 11.3 社区资源

The following links connect to TI community resources. Linked contents are provided "AS IS" by the respective contributors. They do not constitute TI specifications and do not necessarily reflect TI's views; see TI's [Terms of Use](#).

**TI E2E™ Online Community** *TI's Engineer-to-Engineer (E2E) Community*. Created to foster collaboration among engineers. At [e2e.ti.com](http://e2e.ti.com), you can ask questions, share knowledge, explore ideas and help solve problems with fellow engineers.

**Design Support** *TI's Design Support* Quickly find helpful E2E forums along with design support tools and contact information for technical support.

#### 11.4 商标

PowerPAD, E2E are trademarks of Texas Instruments.  
All other trademarks are the property of their respective owners.

#### 11.5 静电放电警告



这些装置包含有限的内置 ESD 保护。存储或装卸时，应将导线一起截短或将装置放置于导电泡棉中，以防止 MOS 门极遭受静电损伤。

#### 11.6 Glossary

[SLYZ022](#) — *TI Glossary*.

This glossary lists and explains terms, acronyms, and definitions.

## 12 机械、封装和可订购信息

以下页中包括机械、封装和可订购信息。这些信息是针对指定器件可提供的最新数据。这些数据会在无通知且不对本文档进行修订的情况下发生改变。欲获得该数据表的浏览器版本，请查阅左侧的导航栏。

**PACKAGING INFORMATION**

Orderable part number	Status (1)	Material type (2)	Package   Pins	Package qty   Carrier	RoHS (3)	Lead finish/ Ball material (4)	MSL rating/ Peak reflow (5)	Op temp (°C)	Part marking (6)
<a href="#">DRV8871DDA</a>	Obsolete	Production	SO PowerPAD (DDA)   8	-	-	Call TI	Call TI	-40 to 125	8871
<a href="#">DRV8871DDAR</a>	Active	Production	SO PowerPAD (DDA)   8	2500   LARGE T&R	Yes	NIPDAU   NIPDAUAG	Level-2-260C-1 YEAR	-40 to 125	8871
DRV8871DDAR.A	Active	Production	SO PowerPAD (DDA)   8	2500   LARGE T&R	Yes	NIPDAU	Level-2-260C-1 YEAR	-40 to 125	8871
DRV8871DDAR.B	Active	Production	SO PowerPAD (DDA)   8	2500   LARGE T&R	Yes	NIPDAU	Level-2-260C-1 YEAR	-40 to 125	8871
DRV8871DDARG4.A	Active	Production	SO PowerPAD (DDA)   8	2500   LARGE T&R	Yes	NIPDAU	Level-2-260C-1 YEAR	-40 to 125	8871
DRV8871DDARG4.B	Active	Production	SO PowerPAD (DDA)   8	2500   LARGE T&R	Yes	NIPDAU	Level-2-260C-1 YEAR	-40 to 125	8871

(1) **Status:** For more details on status, see our [product life cycle](#).

(2) **Material type:** When designated, preproduction parts are prototypes/experimental devices, and are not yet approved or released for full production. Testing and final process, including without limitation quality assurance, reliability performance testing, and/or process qualification, may not yet be complete, and this item is subject to further changes or possible discontinuation. If available for ordering, purchases will be subject to an additional waiver at checkout, and are intended for early internal evaluation purposes only. These items are sold without warranties of any kind.

(3) **RoHS values:** Yes, No, RoHS Exempt. See the [TI RoHS Statement](#) for additional information and value definition.

(4) **Lead finish/Ball material:** Parts may have multiple material finish options. Finish options are separated by a vertical ruled line. Lead finish/Ball material values may wrap to two lines if the finish value exceeds the maximum column width.

(5) **MSL rating/Peak reflow:** The moisture sensitivity level ratings and peak solder (reflow) temperatures. In the event that a part has multiple moisture sensitivity ratings, only the lowest level per JEDEC standards is shown. Refer to the shipping label for the actual reflow temperature that will be used to mount the part to the printed circuit board.

(6) **Part marking:** There may be an additional marking, which relates to the logo, the lot trace code information, or the environmental category of the part.

Multiple part markings will be inside parentheses. Only one part marking contained in parentheses and separated by a "~" will appear on a part. If a line is indented then it is a continuation of the previous line and the two combined represent the entire part marking for that device.

**Important Information and Disclaimer:** The information provided on this page represents TI's knowledge and belief as of the date that it is provided. TI bases its knowledge and belief on information provided by third parties, and makes no representation or warranty as to the accuracy of such information. Efforts are underway to better integrate information from third parties. TI has taken and continues to take reasonable steps to provide representative and accurate information but may not have conducted destructive testing or chemical analysis on incoming materials and chemicals. TI and TI suppliers consider certain information to be proprietary, and thus CAS numbers and other limited information may not be available for release.

In no event shall TI's liability arising out of such information exceed the total purchase price of the TI part(s) at issue in this document sold by TI to Customer on an annual basis.

**OTHER QUALIFIED VERSIONS OF DRV8871 :**

- Automotive : [DRV8871-Q1](#)

NOTE: Qualified Version Definitions:

- Automotive - Q100 devices qualified for high-reliability automotive applications targeting zero defects

**TAPE AND REEL INFORMATION**

**QUADRANT ASSIGNMENTS FOR PIN 1 ORIENTATION IN TAPE**

\*All dimensions are nominal

Device	Package Type	Package Drawing	Pins	SPQ	Reel Diameter (mm)	Reel Width W1 (mm)	A0 (mm)	B0 (mm)	K0 (mm)	P1 (mm)	W (mm)	Pin1 Quadrant
DRV8871DDAR	SO PowerPAD	DDA	8	2500	330.0	12.8	6.4	5.2	2.1	8.0	12.0	Q1

**TAPE AND REEL BOX DIMENSIONS**

\*All dimensions are nominal

Device	Package Type	Package Drawing	Pins	SPQ	Length (mm)	Width (mm)	Height (mm)
DRV8871DDAR	SO PowerPAD	DDA	8	2500	366.0	364.0	50.0



Images above are just a representation of the package family, actual package may vary.  
Refer to the product data sheet for package details.

# DDA0008B



# PACKAGE OUTLINE

## PowerPAD™ SOIC - 1.7 mm max height

PLASTIC SMALL OUTLINE



4214849/A 08/2016

### NOTES:

PowerPAD is a trademark of Texas Instruments.

1. All linear dimensions are in millimeters. Any dimensions in parenthesis are for reference only. Dimensioning and tolerancing per ASME Y14.5M.
2. This drawing is subject to change without notice.
3. This dimension does not include mold flash, protrusions, or gate burrs. Mold flash, protrusions, or gate burrs shall not exceed 0.15 mm per side.
4. This dimension does not include interlead flash. Interlead flash shall not exceed 0.25 mm per side.
5. Reference JEDEC registration MS-012.

# EXAMPLE BOARD LAYOUT

DDA0008B

PowerPAD™ SOIC - 1.7 mm max height

PLASTIC SMALL OUTLINE

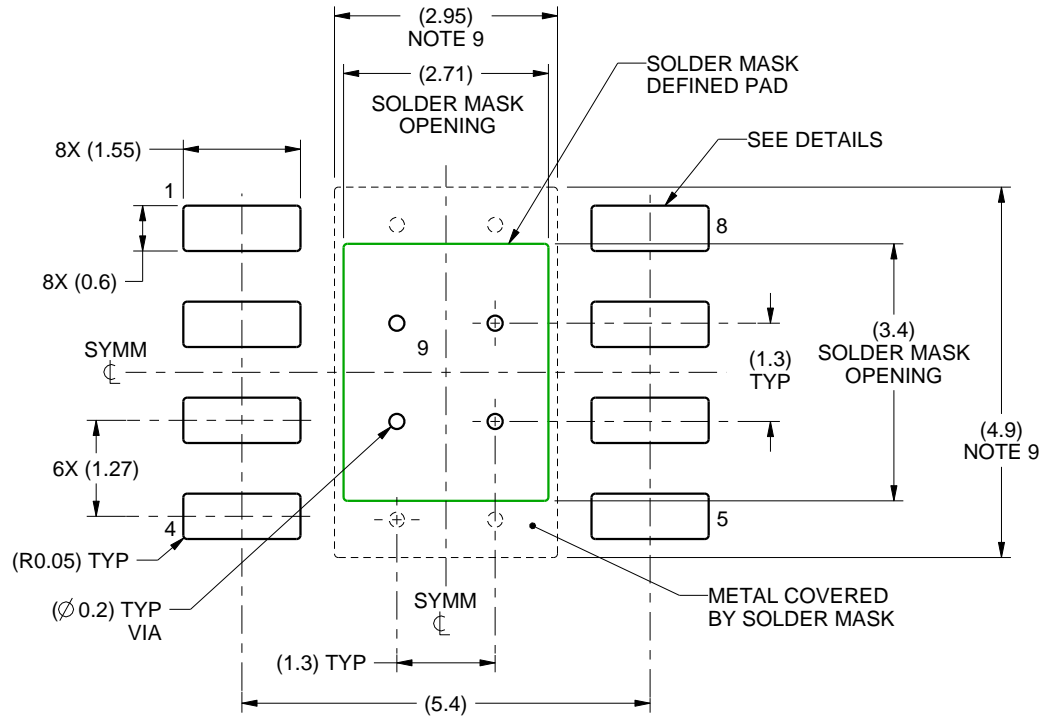

LAND PATTERN EXAMPLE  
SCALE:10X



SOLDER MASK DETAILS  
PADS 1-8

4214849/A 08/2016

NOTES: (continued)

6. Publication IPC-7351 may have alternate designs.
7. Solder mask tolerances between and around signal pads can vary based on board fabrication site.
8. This package is designed to be soldered to a thermal pad on the board. For more information, see Texas Instruments literature numbers SLMA002 ([www.ti.com/lit/slma002](http://www.ti.com/lit/slma002)) and SLMA004 ([www.ti.com/lit/slma004](http://www.ti.com/lit/slma004)).
9. Size of metal pad may vary due to creepage requirement.
10. Vias are optional depending on application, refer to device data sheet. If any vias are implemented, refer to their locations shown on this view. It is recommended that vias under paste be filled, plugged or tented.



# EXAMPLE STENCIL DESIGN

DDA0008B

PowerPAD™ SOIC - 1.7 mm max height

PLASTIC SMALL OUTLINE



SOLDER PASTE EXAMPLE  
 EXPOSED PAD  
 100% PRINTED SOLDER COVERAGE BY AREA  
 SCALE:10X

STENCIL THICKNESS	SOLDER STENCIL OPENING
0.1	3.03 X 3.80
0.125	2.71 X 3.40 (SHOWN)
0.150	2.47 X 3.10
0.175	2.29 X 2.87

4214849/A 08/2016

NOTES: (continued)

11. Laser cutting apertures with trapezoidal walls and rounded corners may offer better paste release. IPC-7525 may have alternate design recommendations.
12. Board assembly site may have different recommendations for stencil design.

DDA (R-PDSO-G8)

PowerPAD™ PLASTIC SMALL-OUTLINE

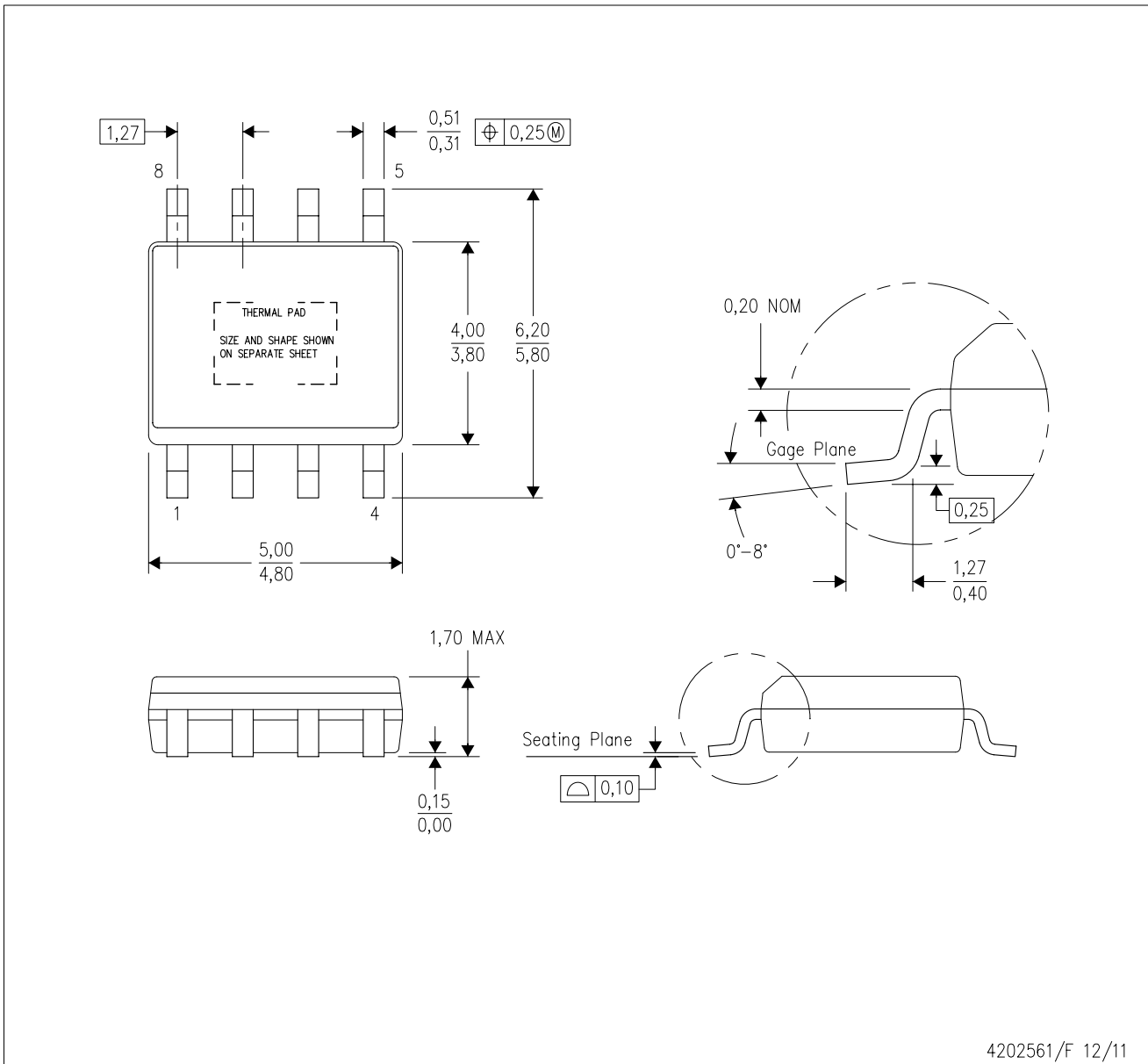

4202561/F 12/11

- NOTES:
- A. All linear dimensions are in millimeters. Dimensioning and tolerancing per ASME Y14.5-1994.
  - B. This drawing is subject to change without notice.
  - C. Body dimensions do not include mold flash or protrusion not to exceed 0,15.
  - D. This package is designed to be soldered to a thermal pad on the board. Refer to Technical Brief, PowerPad Thermally Enhanced Package, Texas Instruments Literature No. SLMA002 for information regarding recommended board layout. This document is available at [www.ti.com](http://www.ti.com) <<http://www.ti.com>>.
  - E. See the additional figure in the Product Data Sheet for details regarding the exposed thermal pad features and dimensions.
  - F. This package complies to JEDEC MS-012 variation BA

PowerPAD is a trademark of Texas Instruments.

DDA (R-PDSO-G8)

PowerPAD™ PLASTIC SMALL OUTLINE

## THERMAL INFORMATION

This PowerPAD™ package incorporates an exposed thermal pad that is designed to be attached to a printed circuit board (PCB). The thermal pad must be soldered directly to the PCB. After soldering, the PCB can be used as a heatsink. In addition, through the use of thermal vias, the thermal pad can be attached directly to the appropriate copper plane shown in the electrical schematic for the device, or alternatively, can be attached to a special heatsink structure designed into the PCB. This design optimizes the heat transfer from the integrated circuit (IC).

For additional information on the PowerPAD package and how to take advantage of its heat dissipating abilities, refer to Technical Brief, PowerPAD Thermally Enhanced Package, Texas Instruments Literature No. SLMA002 and Application Brief, PowerPAD Made Easy, Texas Instruments Literature No. SLMA004. Both documents are available at [www.ti.com](http://www.ti.com).

The exposed thermal pad dimensions for this package are shown in the following illustration.



Exposed Thermal Pad Dimensions

4206322-6/L 05/12

NOTE: A. All linear dimensions are in millimeters

PowerPAD is a trademark of Texas Instruments

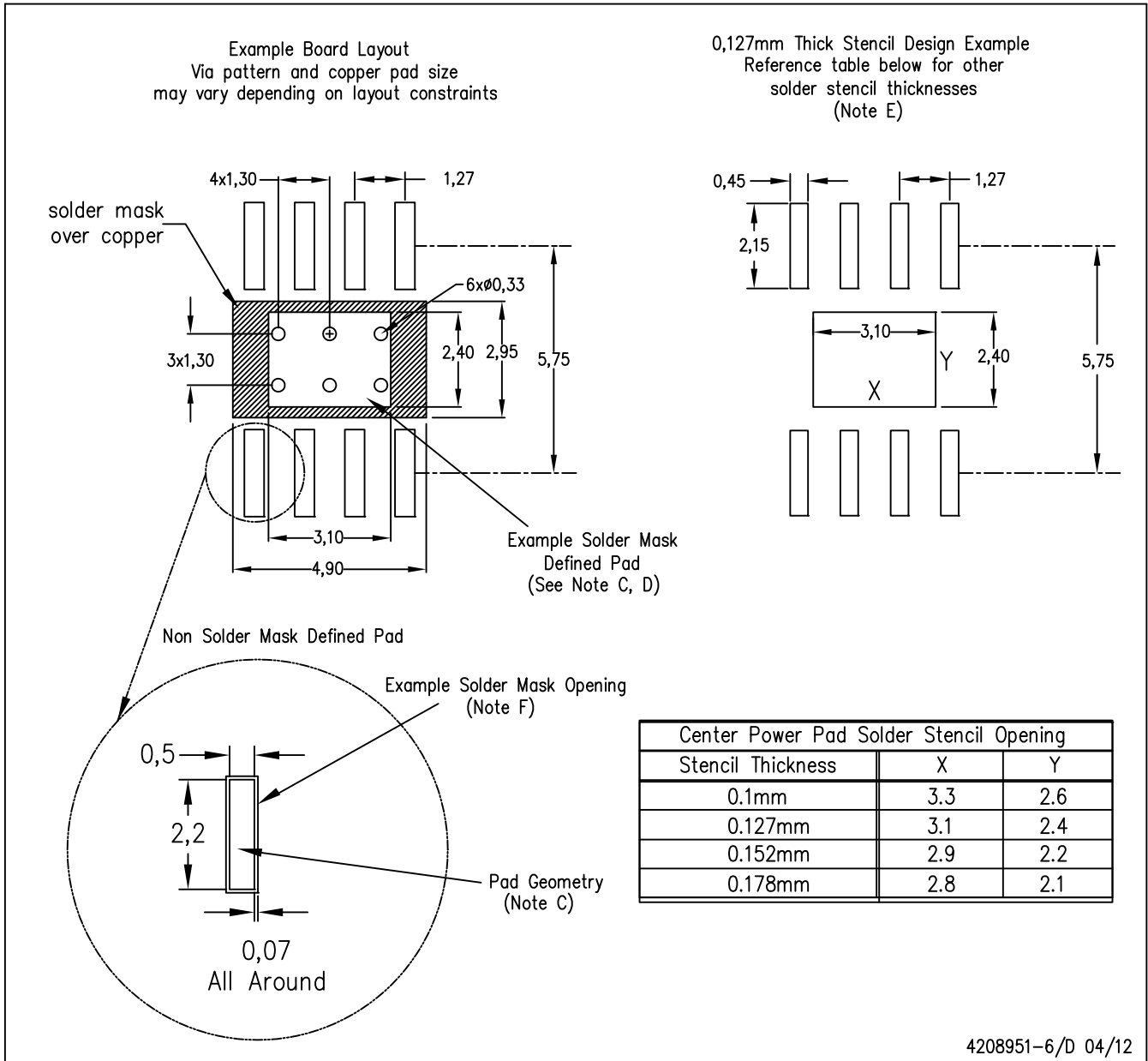

- NOTES:
- A. All linear dimensions are in millimeters.
  - B. This drawing is subject to change without notice.
  - C. Publication IPC-7351 is recommended for alternate designs.
  - D. This package is designed to be soldered to a thermal pad on the board. Refer to Technical Brief, PowerPad Thermally Enhanced Package, Texas Instruments Literature No. SLMA002, SLMA004, and also the Product Data Sheets for specific thermal information, via requirements, and recommended board layout. These documents are available at [www.ti.com](http://www.ti.com) <<http://www.ti.com>>. Publication IPC-7351 is recommended for alternate designs.
  - E. Laser cutting apertures with trapezoidal walls and also rounding corners will offer better paste release. Customers should contact their board assembly site for stencil design recommendations. Example stencil design based on a 50% volumetric metal load solder paste. Refer to IPC-7525 for other stencil recommendations.
  - F. Customers should contact their board fabrication site for solder mask tolerances between and around signal pads.

PowerPAD is a trademark of Texas Instruments.

## 重要通知和免责声明

TI“按原样”提供技术和可靠性数据（包括数据表）、设计资源（包括参考设计）、应用或其他设计建议、网络工具、安全信息和其他资源，不保证没有瑕疵且不做任何明示或暗示的担保，包括但不限于对适销性、某特定用途方面的适用性或不侵犯任何第三方知识产权的暗示担保。

这些资源可供使用 TI 产品进行设计的熟练开发人员使用。您将自行承担以下全部责任：(1) 针对您的应用选择合适的 TI 产品，(2) 设计、验证并测试您的应用，(3) 确保您的应用满足相应标准以及任何其他功能安全、信息安全、监管或其他要求。

这些资源如有变更，恕不另行通知。TI 授权您仅可将这些资源用于研发本资源所述的 TI 产品的相关应用。严禁以其他方式对这些资源进行复制或展示。您无权使用任何其他 TI 知识产权或任何第三方知识产权。您应全额赔偿因在这些资源的使用中对 TI 及其代表造成的任何索赔、损害、成本、损失和债务，TI 对此概不负责。

TI 提供的产品受 [TI 的销售条款](#) 或 [ti.com](#) 上其他适用条款/TI 产品随附的其他适用条款的约束。TI 提供这些资源并不会扩展或以其他方式更改 TI 针对 TI 产品发布的适用的担保或担保免责声明。

TI 反对并拒绝您可能提出的任何其他或不同的条款。

邮寄地址：Texas Instruments, Post Office Box 655303, Dallas, Texas 75265  
版权所有 © 2025，德州仪器 (TI) 公司