

DRV8801A-Q1 DMOS 全桥电机驱动器

1 特性

- 符合汽车应用要求
- 低导通电阻 ($0.83\ \Omega$) 输出
- 低功耗睡眠模式
- 支持 100% 脉宽调制 (PWM) 占空比
- 6.5 至 36V 宽电源电压范围
- 耐热增强型表面贴装封装
- 可配置过流限制
- **保护特性：**
 - V_{BB} 欠压闭锁 (UVLO)
 - 过流保护 (OCP)
 - 电源短路保护
 - 接地短路保护
 - 过热警告 (OTW)
 - 过热关断 (OTS)
 - 引脚 (nFAULT) 指示过流和过热故障条件

2 应用

- 汽车车身系统
- 车门锁
- 加热、通风和空调环境系统 (HVAC) 传动器
- 压电报警

3 说明

DRV8801A-Q1 器件配有 H 桥驱动器，可提供多用途电机驱动器解决方案。此器件能够驱动一个有刷直流电机或者步进电机的一个绕组，以及其它诸如螺线管等器件。一个简单的 PHASE 和 ENABLE 接口可轻松连接到控制器电路。

输出级使用配置为 H 桥的 N 通道功率 MOSFET。DRV8801A-Q1 器件能够提供高达 $\pm 2.8A$ 的峰值输出电流，承受高达 36V 的工作电压。可通过一个内部电荷泵产生所需的栅极驱动电压。

低功耗睡眠模式可将部分内部电路关断，以实现极低的静态电流和功耗。可使用一个专用的 nSLEEP 引脚来设定这个睡眠模式。

提供的内部保护功能包括：欠压锁定、过流保护、电源短路保护、接地短路保护、过热警告和过热关断。过流（包括接地短路和电源短路）和过热故障条件由 nFAULT 引脚指示。

DRV8801A-Q1 器件采用 16 引脚 WQFN 封装，具有可湿性侧面和外露散热焊盘（环保：RoHS，无镉/溴）。

器件信息

器件型号 ⁽¹⁾	封装	封装尺寸 (标称值)
DRV8801A-Q1	WQFN (16)	4.00mm x 4.00mm

(1) 如需了解所有可用封装，请参阅数据表末尾的可订购产品附录。

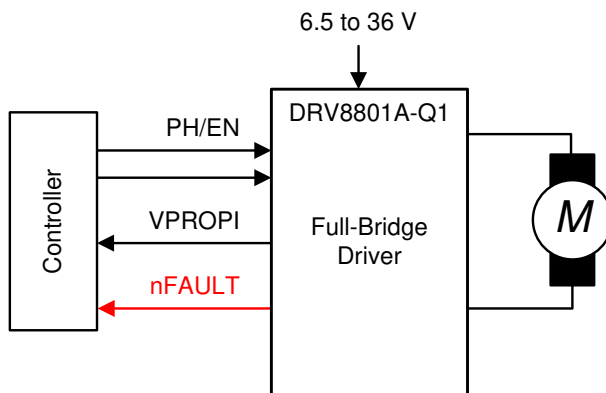

简化版应用示意图



Table of Contents

1 特性.....	1	8.1 Application Information.....	13
2 应用.....	1	8.2 Typical Application.....	13
3 说明.....	1	8.3 Parallel Configuration.....	15
4 Revision History.....	2	9 Power Supply Recommendations.....	19
5 Pin Configuration and Functions.....	3	9.1 Bulk Capacitance.....	19
6 Specifications.....	4	10 Layout.....	20
6.1 Absolute Maximum Ratings.....	4	10.1 Layout Guidelines.....	20
6.2 ESD Ratings.....	4	10.2 Layout Example.....	20
6.3 Recommended Operating Conditions.....	4	10.3 Power Dissipation.....	20
6.4 Thermal Information.....	5	11 Device and Documentation Support.....	21
6.5 Electrical Characteristics.....	5	11.1 Documentation Support.....	21
6.6 Dissipation Ratings.....	6	11.2 Receiving Notification of Documentation Updates.....	21
6.7 Typical Characteristics.....	6	11.3 支持资源.....	21
7 Detailed Description.....	8	11.4 Community Resources.....	21
7.1 Overview.....	8	11.5 Trademarks.....	21
7.2 Functional Block Diagram.....	8	11.6 静电放电警告.....	21
7.3 Feature Description.....	9	11.7 术语表.....	21
7.4 Device Functional Modes.....	12	12 Mechanical, Packaging, And Orderable Information.....	22
8 Application and Implementation.....	13		

4 Revision History

注：以前版本的页码可能与当前版本的页码不同

Changes from Revision C (July 2016) to Revision D (June 2020)	Page
• Improved description for pins CP1, CP2, nFAULT, nSLEEP, VBB and VCP in <i>Pin Functions</i> table.....	3
• Added entries for VCP and CP2 pins in <i>Absolute Maximum Ratings</i> table.....	4
• Removed incorrect duplicate input logic current entry for ENABLE pin in <i>Electrical Characteristics</i> table.....	5
• Added additional information on SENSE pin behavior.....	10
• Added equation for VPROPI to help when connecting pin' s output to ADC in <i>Feature Description</i>	11
• Added die temperature estimation equation utilizing junction to ambient thermal impedance in Application and Implementation section.....	14
• Added information on using motor driver' s pulse width modulating modes in <i>Application and Implementation</i> section.....	14
• Added information on connecting multiple DRV8801-Q1 together to support higher current in <i>Application and Implementation</i> section.....	15
Changes from Revision B (June 2016) to Revision C (July 2016)	Page
• Changed the T_J value for some test conditions for the output ON resistance parameter in the <i>Electrical Characteristics</i>	5
• Added the <i>Documentation Support</i> , <i>Receiving Notification of Documentation Updates</i> , and <i>Community Resources</i> sections	21
Changes from Revision A (September 2014) to Revision B (June 2016)	Page
• Changed the value of T_J from 125°C to 25°C in the test condition (source driver, $I_O = -2.8$ A, $V_{BB} = 8$ to 36 V) for the output ON resistance parameter.....	5
• Added the UVLO hysteresis parameter in the <i>Electrical Characteristics</i> table.....	5
• Added MIN and MAX values for the overcurrent retry time parameter in the <i>Electrical Characteristics</i> table	5
• Updated the <i>Functional Block Diagram</i>	8
• Added t_{pd} to the <i>Overcurrent Control Timing</i> image.....	10

Changes from Revision * (June 2014) to Revision A (September 2014)	Page
• Added TYPE column to the <i>Pin Functions</i> table	3
• Updated the <i>Overcurrent Control Timing</i> image.....	10

5 Pin Configuration and Functions



图 5-1. RMJ Package 16-Pin WQFN With Thermal Pad Top View

表 5-1. Pin Functions

PIN		TYPE	DESCRIPTION
NAME	NO.		
CP1	10	—	Charge pump switching node. Connect a X7R, 0.1- μ F, V_{BB} -rated ceramic capacitor from CP1 to CP2.
CP2	11	—	
ENABLE	4	I	Enables OUTA and OUTB drivers
GND	2	PWR	Ground
	12		
MODE 1	16	I	Mode logic input
MODE 2	5	I	Mode 2 logic input
nFAULT	15	OD	Fault indication. Pulled logic low with fault condition; open-drain output requires an external pullup resistor.
nSLEEP	3	I	Sleep mode input. Logic high to enable device; logic low to enter low-power sleep mode; internal pulldown resistor.
OUTA	6	O	DMOS full-bridge output positive. H-Bridge output A
OUTB	9	O	DMOS full-bridge output negative. H-Bridge output B
PHASE	1	I	Phase logic input for direction control
SENSE	7	IO	Sense power return
V_{BB}	8	PWR	Driver supply voltage. Bypass to GND with 0.1- μ F ceramic capacitors plus a bulk capacitor rated for V_{BB} .
VCP	13	—	Charge pump reservoir capacitor pin. Connect a X7R, 0.1- μ F, 16-V ceramic capacitor to V_{BB} .
VPROPI	14	O	Winding current proportional voltage output
Thermal pad		—	Exposed pad for thermal dissipation; connect to GND pins.

6 Specifications

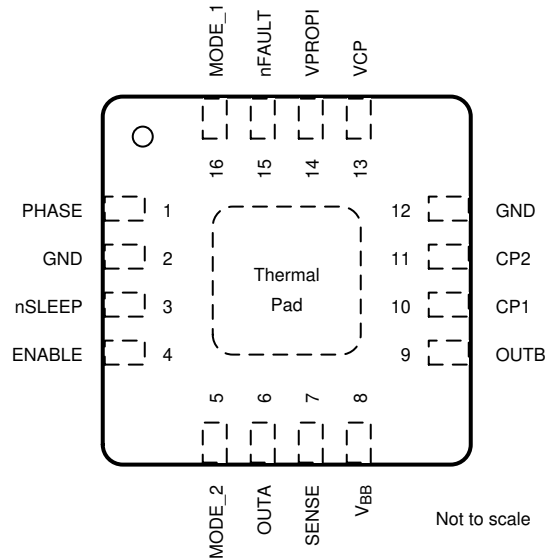
6.1 Absolute Maximum Ratings

over operating free-air temperature range (unless otherwise noted)⁽¹⁾

		MIN	MAX	UNIT
Power supply voltage ⁽²⁾	V _{BB}	- 0.3	40	V
Charge pump voltage	VCP and CP2	- 0.3	V _{BB} + 17	V
Digital pin voltage	PHASE, ENABLE, MODE1, MODE2, nSLEEP, nFAULT	- 0.3	7	V
V _{BB} to OUTx voltage	OUTA and OUTB	- 0.3	36	V
OUTx to GND voltage	OUTA and OUTB	- 0.3	36	V
Sense pin voltage	SENSE	- 0.5	0.5	V
H-bridge output current	OUTA, OUTB, and SENSE		2.8	A
VPROPI pin voltage	VPROPI	- 0.3	3.6	V
Maximum junction temperature, T _J			150	°C
Storage temperature, T _{stg}		- 40	125	°C

- (1) Stresses beyond those listed under *Absolute Maximum Ratings* may cause permanent damage to the device. These are stress ratings only, which do not imply functional operation of the device at these or any other conditions beyond those indicated under *Recommended Operating Conditions*. Exposure to absolute-maximum-rated conditions for extended periods may affect device reliability.
- (2) All voltage values are with respect to network ground terminal.

6.2 ESD Ratings

			VALUE	UNIT	
V _(ESD)	Electrostatic discharge	Human-body model (HBM), per AEC Q100-002 ⁽¹⁾	±2000	V	
		Charged-device model (CDM), per AEC Q100-011	All pins		±500
			Corner pins (1, 4, 5, 8, 9, 12, 13, and 16)		±750

- (1) AEC Q100-002 indicates that HBM stressing shall be in accordance with the ANSI/ESDA/JEDEC JS-001 specification.

6.3 Recommended Operating Conditions

		MIN	MAX	UNIT
V _{BB}	Power supply voltage	6.5	36	V
V _{CC}	Logic supply voltage	0	5.5	V
f _(PWM)	Applied PWM signal (PHASE and ENABLE)	0	100	kHz
I _O	H-bridge peak output current	0	2.8	A
T _A	Ambient temperature	- 40	125	°C

6.4 Thermal Information

THERMAL METRIC ⁽¹⁾		DRV8801A-Q1	UNIT
		RMJ (WQFN)	
		16 PINS	
R _{θJA}	Junction-to-ambient thermal resistance	36.8	°C/W
R _{θJctop}	Junction-to-case (top) thermal resistance	43.4	°C/W
R _{θJB}	Junction-to-board thermal resistance	14.7	°C/W
ψ _{JT}	Junction-to-top characterization parameter	0.7	°C/W
ψ _{JB}	Junction-to-board characterization parameter	14.7	°C/W
R _{θJcbot}	Junction-to-case (bottom) thermal resistance	4.3	°C/W

(1) For more information about traditional and new thermal metrics, see the [Semiconductor and IC Package Thermal Metrics](#) application report.

6.5 Electrical Characteristics

T_A = 25°C, over recommended operating conditions (unless otherwise noted)

PARAMETER		TEST CONDITIONS		MIN	TYP	MAX	UNIT		
POWER SUPPLIES (V_{BB})									
V _{BB}	V _{BB} operating supply voltage			6.5		36	V		
I _{BB}	V _{BB} operating supply current	f _{PWM} < 50 kHz			6		mA		
		Charge pump on, Outputs disabled			3.2				
I _{BB(Q)}	V _{BB} sleep-mode supply current	nSLEEP = 0, T _J = 25°C				10	μA		
CONTROL INPUTS (PHASE, ENABLE, MODE1, MODE2, nSLEEP)									
V _{IL}	Input logic low voltage	PHASE, ENABLE MODE1, MODE2				0.8	V		
V _{IH}	Input logic high voltage				2				
I _{IL}	Input logic low current	PHASE, MODE1, MODE2	V _I = 0.8 V	-20	≤	-2	20	μA	
I _{IH}	Input logic high current		V _I = 2 V		< 1		20		
I _{IL}	Input logic low current	ENABLE	V _I = 0.8 V			16	40	μA	
I _{IH}	Input logic high current		V _I = 2 V			40	100		
V _{IL}	Input logic low voltage	nSLEEP				0.8	V		
V _{IH}	Input logic high voltage				2.7				
I _{IL}	Input logic low current			V _I = 0.8 V		< 1		10	μA
I _{IH}	Input logic high current			V _I = 2 V		27		50	
CONTROL OUTPUTS (nFAULT)									
V _{OL}	Output logic low voltage	I _O = 1 mA				0.4	V		
DMOS DRIVERS (OUTA, OUTB, SENSE, VPROPI)									
r _{DS(on)}	Output ON resistance	Source driver, I _O = -2.8 A, T _J = 25°C, V _{BB} = 6.5 to 36 V			0.48		Ω		
		Source driver, I _O = -2.8 A, T _J = 125°C, V _{BB} = 8 to 36 V			0.74	0.85			
		Source driver, I _O = -2.8 A, T _J = 125°C, V _{BB} = 6.5 to 8 V			0.74	0.9			
		Sink driver, I _O = 2.8 A, T _J = 25°C, V _{BB} = 6.5 to 36 V			0.35				
		Sink driver, I _O = 2.8 A, T _J = 125°C, V _{BB} = 8 to 36 V			0.52	0.7			
		Sink driver, I _O = 2.8 A, T _J = 125°C, V _{BB} = 6.5 to 8 V			0.52	0.75			
V _(TRIP)	SENSE trip voltage	R _(SENSE) between SENSE and GND		450	500	550	mV		
V _f	Body diode forward voltage	Source diode, I _f = -2.8 A				1.4	V		
		Sink diode, I _f = 2.8 A				1.4			
t _{pd}	Propagation delay time	Input edge to source or sink ON			600		ns		
		Input edge to source or sink OFF			100				
t _{COD}	Crossover delay				500		ns		

T_A = 25°C, over recommended operating conditions (unless otherwise noted)

PARAMETER		TEST CONDITIONS	MIN	TYP	MAX	UNIT
G _{D(a)}	Differential amplifier gain	V _{BB} = 8 to 36 V; SENSE = 0.1 to 0.4 V	4.8	5	5.2	V/V
		V _{BB} = 6.5 to 8 V; SENSE = 0.1 to 0.3 V	4.8		5.2	V/V
PROTECTION CIRCUITS						
V _{UV}	UVLO threshold	V _{BB} increasing		5.5	6.4	V
		V _{BB} decreasing			5.7	
	UVLO hysteresis		500		850	mV
I _(OCP)	Overcurrent protection trip level	V _{BB} = 8 to 36 V	3			A
		V _{BB} = 6.5 to 8 V	2.8			A
t _(DEG)	Overcurrent deglitch time			3		μs
t _(OCP)	Overcurrent retry time		0.5	1.2	3	ms
T _(OTW)	Thermal warning temperature	Die temperature T _J		160		°C
T _{hys(OTW)}	Thermal warning hysteresis	Die temperature T _J		15		°C
T _(OTS)	Thermal shutdown temperature	Die temperature T _J		175		°C
T _{hys(OTS)}	Thermal shutdown hysteresis	Die temperature T _J		15		°C

6.6 Dissipation Ratings

PACKAGE	R _{θJA}	T _A = 25°C POWER RATING	DERATING FACTOR ABOVE T _A = 25°C
RMJ	36.8	3 W	27 mW/C

6.7 Typical Characteristics

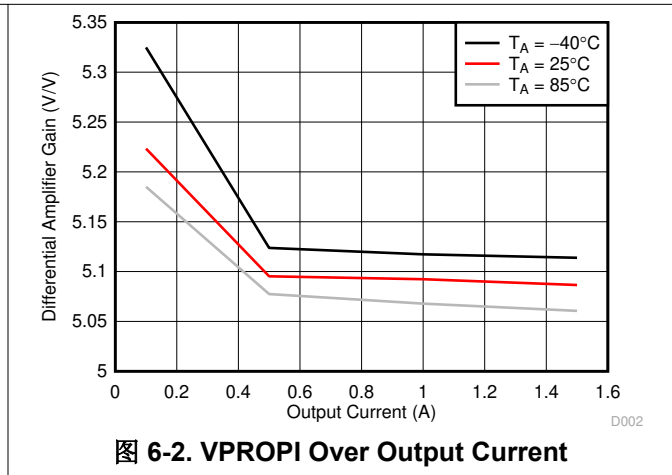
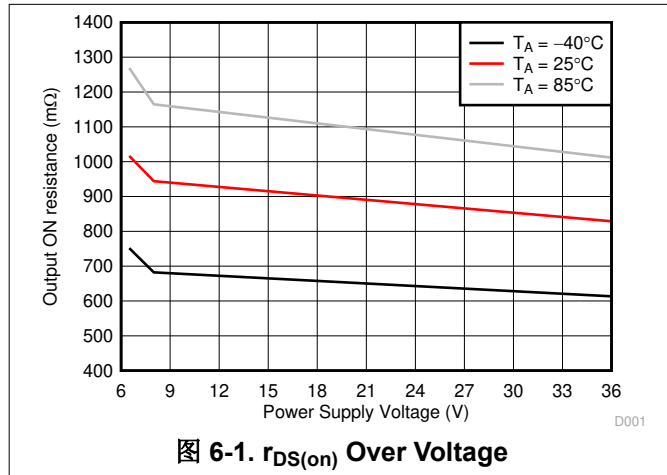



图 6-3. VCP Voltage vs V_{BB}

7 Detailed Description

7.1 Overview

The DRV8801A-Q1 device is an integrated motor driver solutions for brushed-DC motors. The device integrates a DMOS H-bridge and current sense and protection circuitry. The device can be powered with a supply voltage between 6.5 V and 36 V, and is capable of providing an output current up to 2.8-A peak.

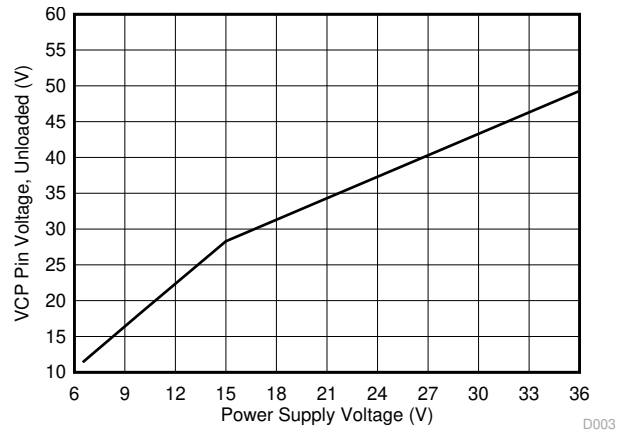
A simple PHASE and ENABLE interface allows control of the motor speed and direction.

A shunt amplifier output is provided for accurate current measurements by the system controller. The VPROPI pin outputs a voltage that is five-times the voltage seen at the SENSE pin.

A low-power sleep mode is included which allows the system to save power when not driving the motor.

7.2 Functional Block Diagram

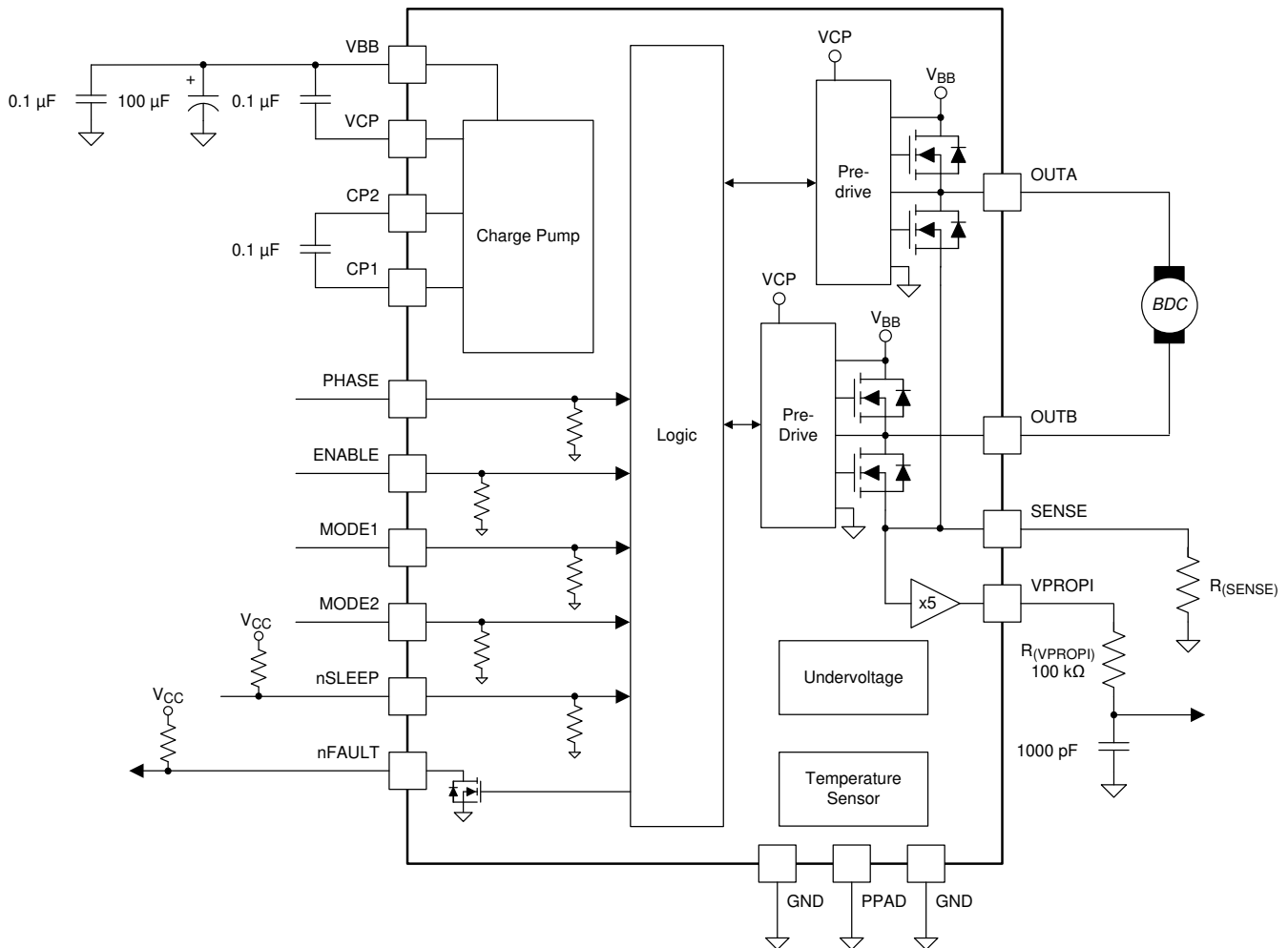

7.3 Feature Description

7.3.1 Power Supervisor

The control input, nSLEEP, is used to minimize power consumption when the DRV8801A-Q1 device is not in use. A logic low on the nSLEEP input disables much of the internal circuitry, including the internal voltage rails and charge pump. A logic high on this input pin results in normal operation. When switching from low to high, the user should allow a 1-ms delay before applying PWM signals. This time is needed for the charge pump to stabilize.

7.3.2 Bridge Control

The following table shows the logic for the DRV8801A-Q1:

nSLEEP	PHASE	ENABLE	MODE1	MODE2	OUTA	OUTB	OPERATION
0	X	X	X	X	Z	Z	Sleep mode
1	0	1	X	X	L	H	Reverse
1	1	1	X	X	H	L	Forward
1	0	0	0	X	H	L	Fast decay
1	1	0	0	X	L	H	Fast decay
1	X	0	1	0	L	L	Low-side Slow decay
1	X	0	1	1	H	H	High-side Slow decay

To prevent reversal of current during fast-decay synchronous rectification, outputs go to the high impedance state as the current approaches 0 A.

The path of current flow for each of the states in the above logic table is shown in [图 7-1](#).

7.3.2.1 MODE 1

Input MODE 1 is used to toggle between fast-decay mode and slow-decay mode. A logic high puts the device in slow-decay mode.

7.3.2.2 MODE 2

MODE 2 is used to select which set of drivers (high side versus low side) is used during the slow-decay recirculation. MODE 2 is meaningful only when MODE 1 is asserted high. A logic high on MODE 2 has current recirculation through the high-side drivers. A logic low has current recirculation through the low-side drivers.

7.3.3 Fast Decay with Synchronous Rectification

This decay mode is equivalent to a phase change where the FETs opposite of the driving FETs are switched on (2 in [图 7-1](#)). When in fast decay, the motor current is not allowed to go negative because this would cause a change in direction. Instead, as the current approaches zero, the drivers turn off. See the [# 10.3](#) section for an equation to calculate power.

7.3.4 Slow Decay with Synchronous Rectification (Brake Mode)

In slow-decay mode, both low-side and high-side drivers turn on, allowing the current to circulate through the low-side and high-side body diodes of the H-bridge and the load (3 and 4 in [图 7-1](#)). See the [# 10.3](#) section for equations to calculate power for both high-side and low-side slow decay.



图 7-1. H-Bridge Operation Modes

7.3.5 Charge Pump

The charge pump is used to generate a supply above V_{BB} to drive the source-side DMOS gates. A $0.1\text{-}\mu\text{F}$ ceramic monolithic capacitor should be connected between CP1 and CP2 for pumping purposes. A $0.1\text{-}\mu\text{F}$ ceramic monolithic capacitor should be connected between VCP and V_{BB} to act as a reservoir to run the high-side DMOS devices.

7.3.6 SENSE

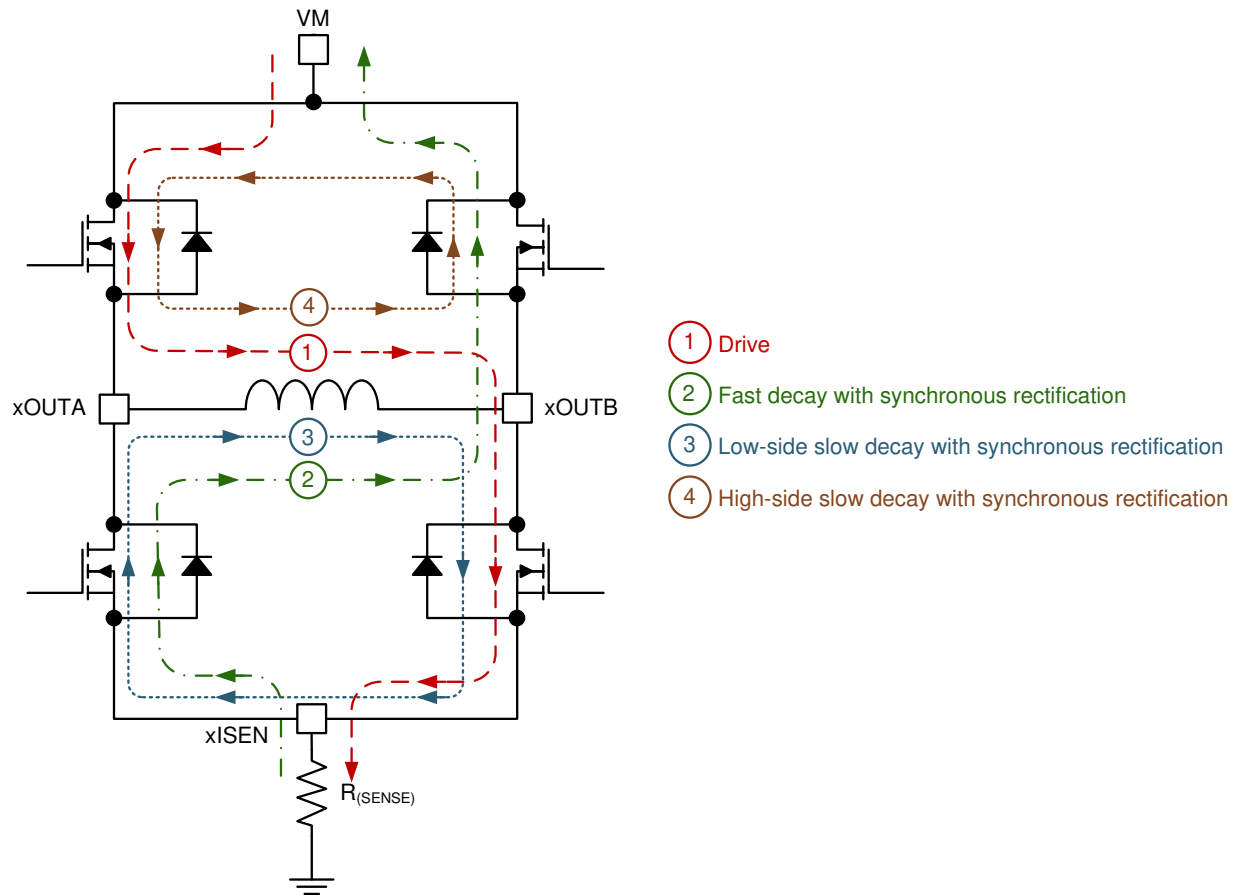
A low-value SENSE resistor is used to set an overcurrent threshold lower than the default maximum value of 2.8 A and to provide a voltage for VPROPI. This SENSE resistor must be connected between the SENSE pin and ground. To minimize ground-trace IR drops in sensing the output current level, the current-sensing resistor should have an independent ground return to the star ground point. This trace should be as short as possible. For low-value sense resistors, the IR drops in the PCB can be significant, and should be taken into account.

A direct connection to ground yields a SENSE voltage equal to zero. In that case, maximum current is 2.8 A and VPROPI outputs 0 V. A resistor connected as explained before, will yield a VPROPI output as detailed in section 节 7.3.7. Size the sense resistor such that voltage drop across the sense resistor is less than 500 mV under normal loading conditions. Any voltage equal or larger to 500 mV will signal the device to hi-Z the H-bridge output as overcurrent trip threshold has been reached. In this case, device will enter recirculation as stipulated by the MODE input pin. The device automatically retries with a period of $t_{(OCP)}$.

方程式 1 shows the value of the resistor to a particular current setting.

$$R_{\text{sense}} = \frac{500 \text{ mV}}{I_{\text{trip}}} \quad (1)$$

The overcurrent trip level selected cannot be greater than $I_{(OCP)}$.



图 7-2. Overcurrent Control Timing

7.3.7 VPROPI

The analog output VPROPI offers SENSE current information as an analog voltage proportional to the current flowing through the DC motor winding. This voltage can be used by an analog to digital converter and microcontroller to accurately determine how much current is flowing through the controlled DC motor. See 节 7.3.6 for guidance on selecting a SENSE resistor value.

7.3.7.1 Connecting VPROPI Output to ADC

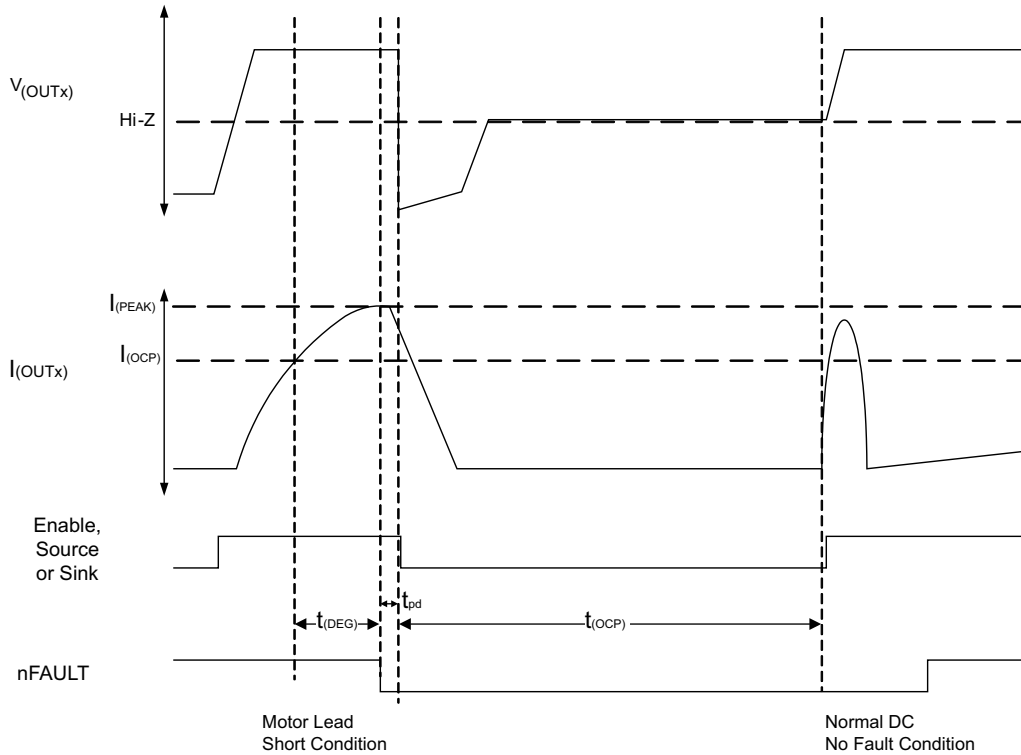
The analog output VPROPI varies proportionally with the SENSE voltage according to 方程式 2. It's important to note even if V_{SENSE} is negative VPROPI will remain at 0 V.

$$VPROPI = 5 \times V_{SENSE} \quad (2)$$

An RC network in series with the VPROPI output is recommended, if this voltage is to be sampled by an analog to digital converter.



图 7-3. RC Network in Series With the VPROPI Output

It is imperative to realize that VPROPI will decrease to 0 V while the H-Bridge enters slow decay recirculation.

7.3.8 Protection Circuits

The DRV8801A-Q1 device is fully protected against V_{BB} undervoltage, overcurrent, and overtemperature events.

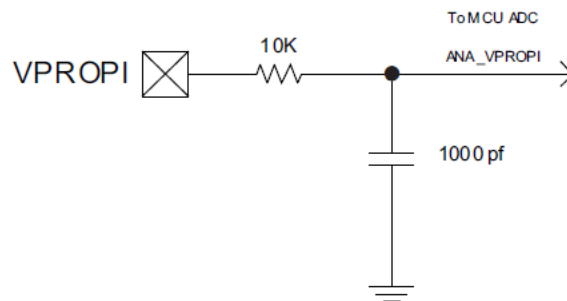
FAULT	ERROR REPORT	H-BRIDGE	CHARGE PUMP	RECOVERY
V_{BB} undervoltage (UVLO)	No error report - nFAULT is hi-Z	Disabled	Shut Down	$V_{BB} > V_{UVLO}$ RISING
Overcurrent (OCP)	nFAULT pulled low	Disabled	Operating	Retry time, $t_{(OCP)}$
Overtemperature Warning (OTW)	nFAULT pulled low	Enabled	Operating	$T_J < T_{(OTW)} - T_{hys(OTW)}$
Overtemperature Shutdown (OTS)	nFAULT remains pulled low (set during OTW)	Disabled	Shut Down	$T_J < T_{(OTS)} - T_{hys(OTS)}$

7.3.8.1 V_{BB} Undervoltage Lockout (UVLO)

If at any time the voltage on the V_{BB} pin falls below the undervoltage lockout threshold voltage, all FETs in the H-bridge are disabled and the charge pump is disabled. The nFAULT pin does not report the UVLO fault condition and remains hi-Z. Operation resumes when V_{BB} rises above the UVLO threshold.

7.3.8.2 Overcurrent Protection (OCP)

The current flowing through the high-side and low-side drivers is monitored to ensure that the motor lead is not shorted to supply or ground. If a short is detected, all FETs in the H-bridge are disabled, nFAULT is driven low, and a $t_{(OCP)}$ fault timer is started. After this period, $t_{(OCP)}$, the device is then allowed to follow the input commands and another turn-on is attempted (nFAULT releases during this attempt). If there is still a fault condition, the cycle repeats. If the short condition is not present after $t_{(OCP)}$ expires, normal operation resumes and nFAULT is released.

7.3.8.3 Overtemperature Warning (OTW)

If the die temperature increases past the thermal warning threshold the nFAULT pin is driven low. When the die temperature has fallen below the hysteresis level, the nFAULT pin is released. If the die temperature continues to increase, the device enters overtemperature shutdown as described in the [§ 7.3.8.4](#) section.

7.3.8.4 Overtemperature Shutdown (OTS)

If the die temperature exceeds the thermal shutdown temperature, all FETs in the H-bridge are disabled and the charge pump shuts down. The nFAULT pin remains pulled low during this fault condition. When the die temperature falls below the hysteresis threshold, operation automatically resumes.

7.4 Device Functional Modes

The DRV8801A-Q1 device is active unless the nSLEEP pin is brought logic low. In sleep mode the charge pump is disabled and the H-bridge FETs are disabled hi-Z. The DRV8801A-Q1 device is brought out of sleep mode automatically if nSLEEP is brought logic high.

8 Application and Implementation

8.1 Application Information

The DRV8801A-Q1 device is used in medium voltage brushed-DC motor control applications.

8.2 Typical Application



图 8-1. Typical Application Diagram

8.2.1 Design Requirements

The example supply voltage for this design is $V_{BB} = 18\text{ V}$.

8.2.2 Detailed Design Procedure

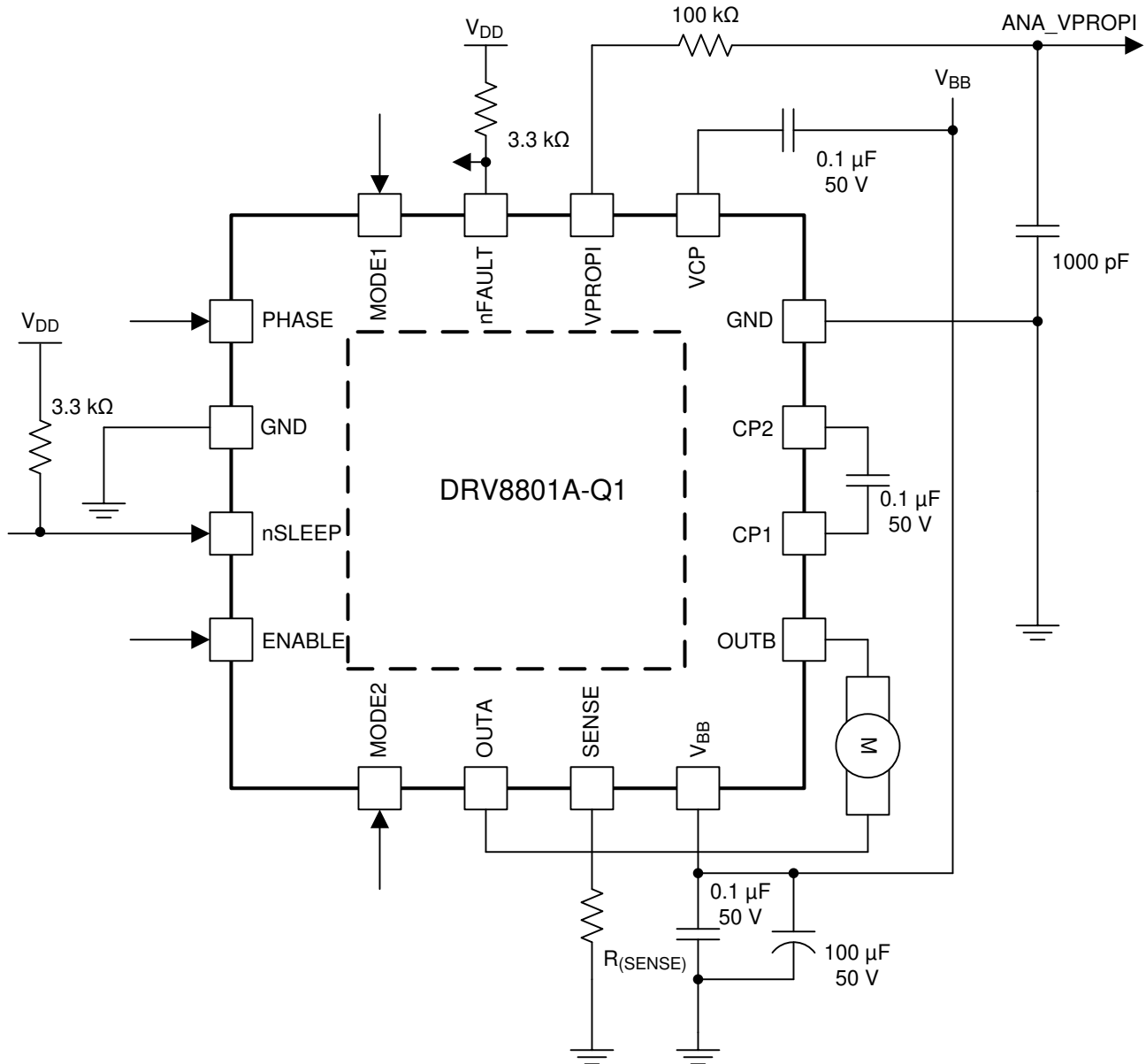
8.2.2.1 Drive Current

This current path is through the high-side sourcing DMOS driver, motor winding, and low-side sinking DMOS driver. Power dissipation I^2R losses in one source and one sink DMOS driver, as shown in [方程式 3](#).

8.2.2.2

$$P_D = I^2(r_{DS(on)Source} + r_{DS(on)Sink}) \quad (3)$$

8.2.2.3 Slow-Decay SR (Brake Mode)

In slow-decay mode, both low-side sinking drivers turn on, allowing the current to circulate through the low side of the H-bridge (two sink drivers) and the load. Power dissipation I^2R losses in the two sink DMOS drivers as shown in [方程式 4](#)

$$P_D = I^2(2 \times r_{DS(on)Sink}) \quad (4)$$

8.2.3 Thermal Considerations

Although DRV8801A-Q1 is rated at 2.8-A of current handling, the previous only holds true as long as the internal temperature does not exceed 170°C . In order to operate at this rate, the following measures must be taken under consideration.

8.2.3.1 Junction-to-Ambient Thermal Impedance (θ_{JA})

At any given time during the steady state portion of the cycle, two FETs are enabled: A high side sourcing FET and a low side sinking FET. The increase in die temperature above ambient can be estimated by [方程式 5](#)

$$T_{die} = \theta_{JA} \frac{^\circ\text{C}}{\text{W}} \times I_{winding}^2 \times RDS_{ON} + T_A \quad (5)$$

8.2.4 Pulse-Width Modulating

8.2.4.1 Pulse-Width Modulating ENABLE

The most common H-Bridge direction/speed control scheme is to use a conventional GPIO output for the PHASE (selects direction) and pulse-width modulate ENABLE for speed control.

8.2.4.2 Pulse-Width Modulating PHASE

A technique that uses a speed/direction control scheme where ENABLE is connected to a GPIO output and the PHASE is pulse-width modulated. In this case, both direction and speed are controlled with a single signal. ENABLE is only used to disable the motor and stop all current flow.

When pulse-width modulating PHASE, a 50% duty cycle will stop the motor. Duty cycles above 50% will have the motor moving on the clockwise direction with proportional control; 100% duty cycle represents full speed.

Duty cycles below 50% will have the motor rotating with a counter clockwise direction; 0% duty cycle represents full speed.

8.2.5 Application Curves



图 8-2. 75% Drive, 25% Slow Decay; $f_{(PWM)} = 5 \text{ kHz}$



图 8-3. 75% Drive, 25% Fast Decay; $f_{(PWM)} = 5 \text{ kHz}$

8.3 Parallel Configuration

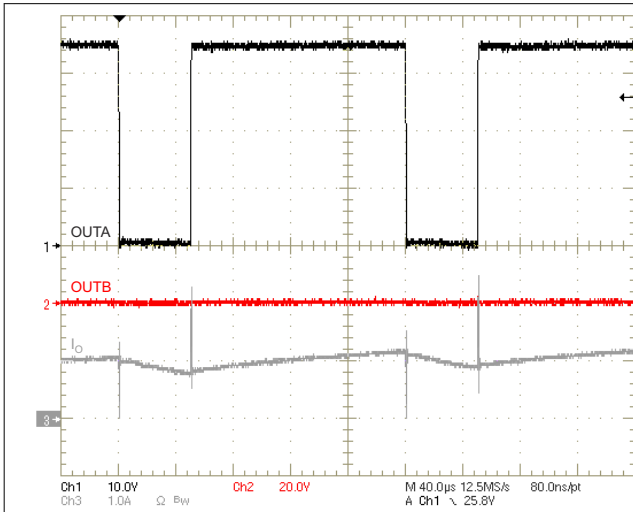
It is possible to drive higher than the 2.8 A of current by connecting more than one devices in parallel. To properly use this option the guidelines documented below must be followed.

8.3.1 Parallel Connections

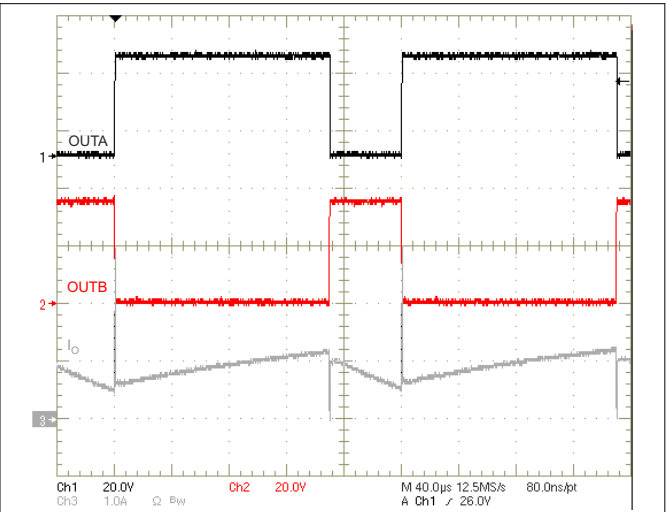
图 8-4 shows the signals that need to be connected together. ENABLE, PHASE, MODE 1, MODE 2, nSLEEP, OUTA, OUTB, SENSE, VBB and GND.



图 8-4. Functional Block Diagram (Connected Signals)

8.3.2 Non - Parallel Connections

图 8-5 shows the signals that should not be connected together and will be driven on an individual basis. These are: VCP, CP1, CP2, and VPROPI.

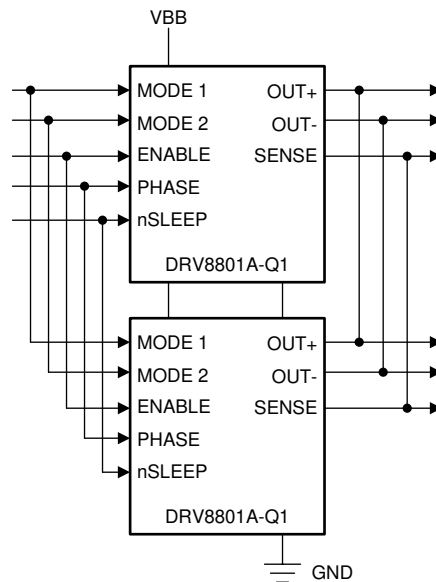

图 8-5. Functional Block Diagram (Individual Signals)

8.3.3 Wiring nFAULT as Wired OR

Since nFAULT is an open drain output, multiple nFAULT outputs can be paralleled with a single resistor. The end result is a wired OR configuration. When any individual nFAULT output goes to a logic low, the wired OR output will go to the same logic low. There is no need to determine which device signaled the fault condition, as once they are connected in parallel they function as a single device.

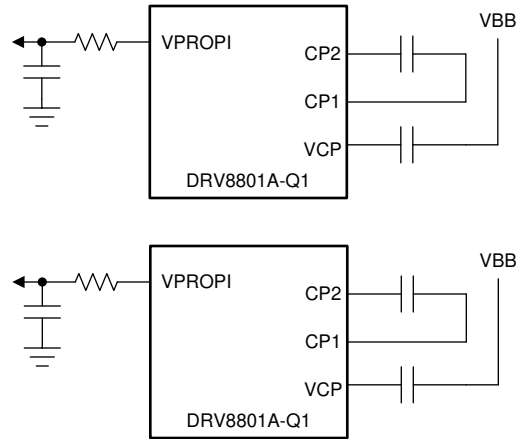

图 8-6. nFAULT as Wired OR

8.3.4 Electrical Considerations

8.3.4.1 Device Spacing

It is recommended that devices be connected as close as possible and with trace lengths as short as possible. Doing this minimizes the potential of generating timing differences between devices. Although it may seem like a harmful situation for the power stage, DRV8801A-Q1 contains enough protection to effectively deal with enable time skews from device to device. This consideration focuses on motion quality, as total current needed for acceleration and proper speed control will only be available when all power stages are brought online.

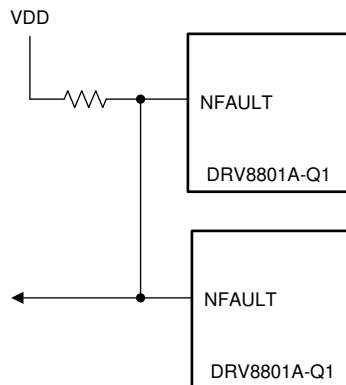
8.3.4.2 Recirculation Current Handling

During recirculation, it is not possible to synchronize all devices connected in parallel so that the current is equally distributed. Also, during the asynchronous portion of the current decay, the body diode with the lowest forward voltage will start conducting and sink all of the current. Said body diode is not meant to handle the new increased current capacity and will be severely affected if allowed to sink current of said magnitude.

In order to assure proper operation when devices are connected in parallel, it is imperative that external schottky diodes be used. These schottky diodes will conduct during the asynchronous portion of the recirculation mode and will sink the inductive load current until the respective FET switches are brought online.

Schottky diodes should be connected as shown in [图 8-7](#).



图 8-7. Schottky Diodes Connection

8.3.4.3 Sense Resistor Selection

The guideline for the SENSE resistor chosen doesn't change in parallel mode. As the goal of this configuration is to evenly distribute the current load across multiple devices, each device should be configured with the same I_{TRIP} setting. Therefore, the same SENSE resistor should be used for all devices connected in parallel.

Connection of the SENSE resistors should be as shown in [图 8-8](#).

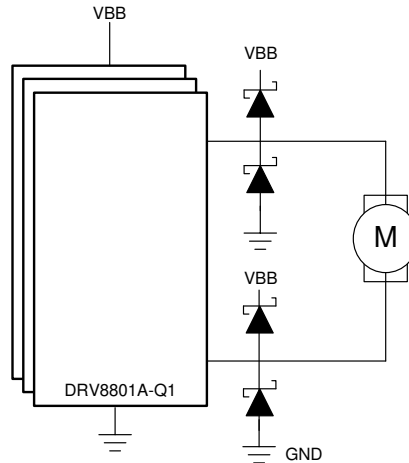

图 8-8. SENSE Resistors Connection

8.3.4.4 Maximum System Current

The idea behind placing multiple devices in parallel is to increase maximum drive current. At first glance, it may seem that the new increased I_{TRIP} setting is given by [方程式 6](#).

$$\text{System } I_{TRIP} = (I_{TRIP} \times N) \tag{6}$$

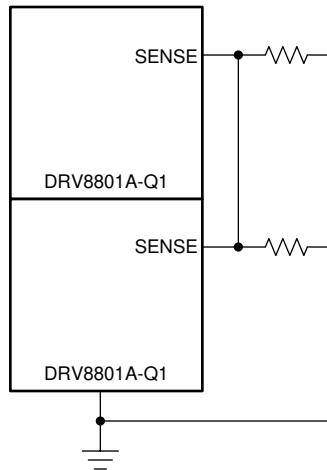
Where:

N is the number of devices connected in parallel.

I_{TRIP} is the individual I_{TRIP} value per device.

However, although in theory accurate, due to tolerances in internal SENSE amplifier/comparator circuitry, the system I_{TRIP} should be expected to be less than the addition of all the individual I_{TRIP} . The reason for this is that as soon as one of the devices senses a current for which the H Bridge should be disabled, the remaining devices will end up having to conduct the same current but with less capacity. Therefore, remaining devices are expected to get disabled shortly after.

A good rule of thumb is to expect 90% of the theoretical maximum.

By way of example, if the system level requirements indicate that 6 A of current are required to meet the motion control requirements, then:

$$6 \text{ A} = (2.8 \text{ A} \times 0.9)N$$

$$N = (6 \text{ A}) / (2.8 \text{ A} \times 0.9)$$

$$N = 2.38$$

In this example, three devices would be required to safely meet the needs of the system.

9 Power Supply Recommendations

The DRV8801A-Q1 device is designed to operate from an input-voltage supply (V_{BB}) range between 6.5 V and 36 V. One 0.1- μF ceramic capacitor rated for V_{BB} must be placed as close as possible to the V_{BB} pin. In addition to the local decoupling caps, additional bulk capacitance is required and must be sized accordingly to the application requirements.

9.1 Bulk Capacitance

Bulk capacitance sizing is an important factor in motor drive system design. This sizing is dependent on a variety of factors including:

- Type of power supply
- Acceptable supply voltage ripple
- Parasitic inductance in the power supply wiring
- Type of motor (brushed DC, brushless DC, stepper)
- Motor startup current
- Motor braking method

The inductance between the power supply and motor drive system will limit the rate current can change from the power supply. If the local bulk capacitance is too small, the system will respond to excessive current demands or dumps from the motor with a change in voltage. Size the bulk capacitance to meet acceptable voltage ripple levels.

The data sheet generally provides a recommended value but system-level testing is required to determine the appropriate sized bulk capacitor.



图 9-1. Bulk Capacitance

10 Layout

10.1 Layout Guidelines

The printed circuit board (PCB) should use a heavy ground plane. For optimum electrical and thermal performance, the DRV8801A-Q1 device must be soldered directly onto the board. On the bottom side of the DRV8801A-Q1 device is a thermal pad, which provides a path for enhanced thermal dissipation. The thermal pad should be soldered directly to an exposed surface on the PCB. Thermal vias are used to transfer heat to other layers of the PCB. For more information on this technique, refer to [QFN/SON PCB Attachment](#).

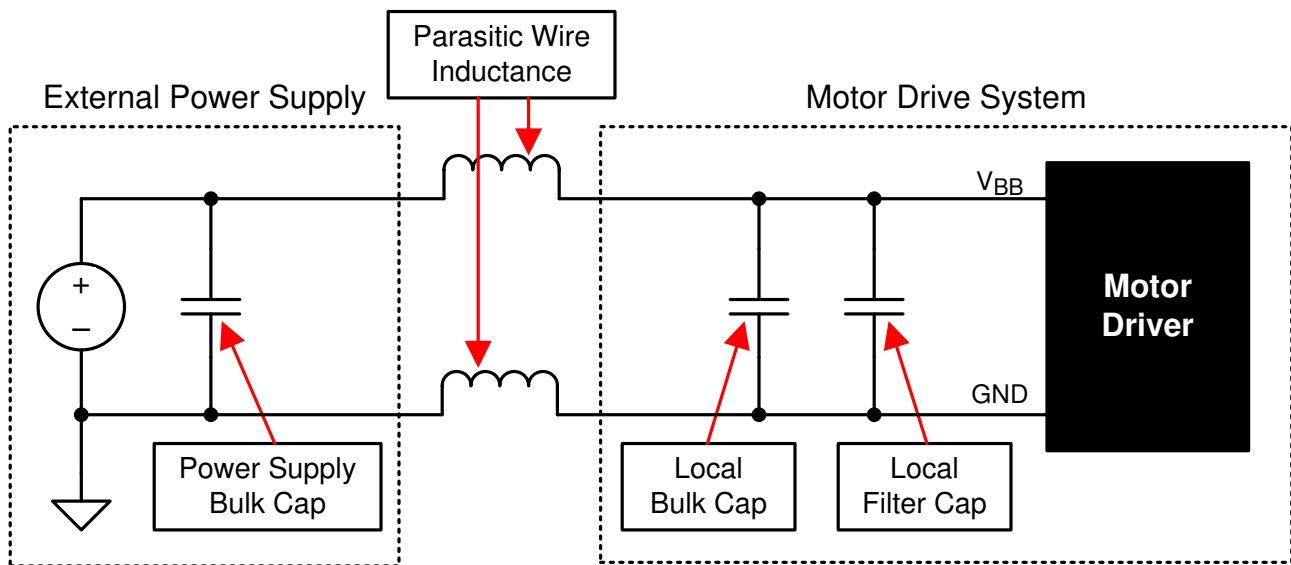
The load supply pin, V_{BB} , should be decoupled with an electrolytic capacitor (typically 100 μ F) in parallel with a ceramic capacitor placed as close as possible to the device. In order to minimize lead inductance, the ceramic capacitors between the VCP and V_{BB} pins, connected to the REG pin, and the capacitors between the CP1 and CP2 pins should be as close to the pins of the device as possible.

10.2 Layout Example



图 10-1. DRV8801A-Q1 Layout

10.3 Power Dissipation

First-order approximation of power dissipation in the DRV8801A-Q1 device can be calculated by examining the power dissipation in the full-bridge during each of the operation modes. The DRV8801A-Q1 device uses synchronous rectification. During the decay cycle, the body diode is shorted by the low- $r_{DS(on)}$ driver, which in turn reduces power dissipation in the full-bridge. In order to prevent shoot through (high-side and low-side drivers on the same side are ON at the same time), the DRV8801A-Q1 device implements a 500-ns typical crossover delay time. During this period, the body diode in the decay current path conducts the current until the DMOS driver turns on. High-current and high-ambient-temperature applications should take this into consideration. In addition, motor parameters and switching losses can add power dissipation that could affect critical applications.

11 Device and Documentation Support

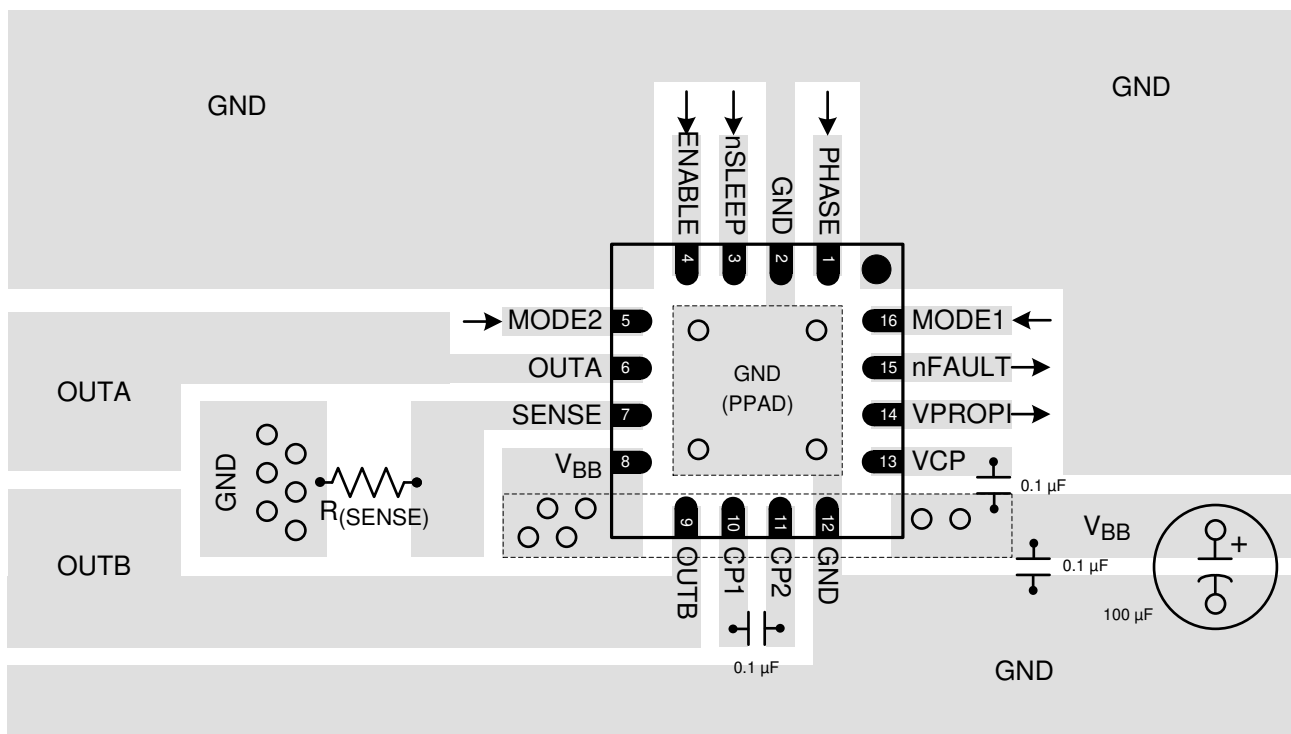
11.1 Documentation Support

11.1.1 Related Documentation

For related documentation, see the following:

[QFN/SON PCB Attachment](#)

11.2 Receiving Notification of Documentation Updates

To receive notification of documentation updates, navigate to the device product folder on ti.com. In the upper right corner, click on *Alert me* to register and receive a weekly digest of any product information that has changed. For change details, review the revision history included in any revised document.

11.3 支持资源

TI E2E™ 支持论坛是工程师的重要参考资料，可直接从专家获得快速、经过验证的解答和设计帮助。搜索现有解答或提出自己的问题可获得所需的快速设计帮助。

链接的内容由各个贡献者“按原样”提供。这些内容并不构成 TI 技术规范，并且不一定反映 TI 的观点；请参阅 TI 的《使用条款》。

11.4 Community Resources

11.5 Trademarks

TI E2E™ is a trademark of Texas Instruments.

所有商标均为其各自所有者的财产。

11.6 静电放电警告



静电放电 (ESD) 会损坏这个集成电路。德州仪器 (TI) 建议通过适当的预防措施处理所有集成电路。如果不遵守正确的处理和安装程序，可能会损坏集成电路。

ESD 的损坏小至导致微小的性能降级，大至整个器件故障。精密的集成电路可能更容易受到损坏，这是因为非常细微的参数更改都可能会导致器件与其发布的规格不相符。

11.7 术语表

[TI 术语表](#) 本术语表列出并解释了术语、首字母缩略词和定义。

12 Mechanical, Packaging, And Orderable Information

The following pages include mechanical, packaging, and orderable information. This information is the most current data available for the designated devices. This data is subject to change without notice and revision of this document. For browser-based versions of this data sheet, refer to the left-hand navigation.

重要声明和免责声明

TI 提供技术和可靠性数据 (包括数据表)、设计资源 (包括参考设计)、应用或其他设计建议、网络工具、安全信息和其他资源, 不保证没有瑕疵且不做任何明示或暗示的担保, 包括但不限于对适销性、某特定用途方面的适用性或不侵犯任何第三方知识产权的暗示担保。

这些资源可供使用 TI 产品进行设计的熟练开发人员使用。您将自行承担以下全部责任: (1) 针对您的应用选择合适的 TI 产品, (2) 设计、验证并测试您的应用, (3) 确保您的应用满足相应标准以及任何其他安全、安保或其他要求。这些资源如有变更, 恕不另行通知。TI 授权您仅可将这些资源用于研发本资源所述的 TI 产品的应用。严禁对这些资源进行其他复制或展示。您无权使用任何其他 TI 知识产权或任何第三方知识产权。您应全额赔偿因在这些资源的使用中对 TI 及其代表造成的任何索赔、损害、成本、损失和债务, TI 对此概不负责。

TI 提供的产品受 TI 的销售条款 (<https://www.ti.com/legal/termsofsale.html>) 或 [ti.com](https://www.ti.com) 上其他适用条款/TI 产品随附的其他适用条款的约束。TI 提供这些资源并不会扩展或以其他方式更改 TI 针对 TI 产品发布的适用的担保或担保免责声明。

邮寄地址: Texas Instruments, Post Office Box 655303, Dallas, Texas 75265

Copyright © 2021, 德州仪器 (TI) 公司

PACKAGING INFORMATION

Orderable part number	Status (1)	Material type (2)	Package Pins	Package qty Carrier	RoHS (3)	Lead finish/ Ball material (4)	MSL rating/ Peak reflow (5)	Op temp (°C)	Part marking (6)
DRV8801AQRMJRQ1	Active	Production	WQFN (RMJ) 16	3000 LARGE T&R	Yes	NIPDAU	Level-3-260C-168 HR	-40 to 125	DRV8801 ARMJQ1
DRV8801AQRMJRQ1.A	Active	Production	WQFN (RMJ) 16	3000 LARGE T&R	Yes	NIPDAU	Level-3-260C-168 HR	-40 to 125	DRV8801 ARMJQ1

(1) **Status:** For more details on status, see our [product life cycle](#).

(2) **Material type:** When designated, preproduction parts are prototypes/experimental devices, and are not yet approved or released for full production. Testing and final process, including without limitation quality assurance, reliability performance testing, and/or process qualification, may not yet be complete, and this item is subject to further changes or possible discontinuation. If available for ordering, purchases will be subject to an additional waiver at checkout, and are intended for early internal evaluation purposes only. These items are sold without warranties of any kind.

(3) **RoHS values:** Yes, No, RoHS Exempt. See the [TI RoHS Statement](#) for additional information and value definition.

(4) **Lead finish/Ball material:** Parts may have multiple material finish options. Finish options are separated by a vertical ruled line. Lead finish/Ball material values may wrap to two lines if the finish value exceeds the maximum column width.

(5) **MSL rating/Peak reflow:** The moisture sensitivity level ratings and peak solder (reflow) temperatures. In the event that a part has multiple moisture sensitivity ratings, only the lowest level per JEDEC standards is shown. Refer to the shipping label for the actual reflow temperature that will be used to mount the part to the printed circuit board.

(6) **Part marking:** There may be an additional marking, which relates to the logo, the lot trace code information, or the environmental category of the part.

Multiple part markings will be inside parentheses. Only one part marking contained in parentheses and separated by a "~" will appear on a part. If a line is indented then it is a continuation of the previous line and the two combined represent the entire part marking for that device.

Important Information and Disclaimer: The information provided on this page represents TI's knowledge and belief as of the date that it is provided. TI bases its knowledge and belief on information provided by third parties, and makes no representation or warranty as to the accuracy of such information. Efforts are underway to better integrate information from third parties. TI has taken and continues to take reasonable steps to provide representative and accurate information but may not have conducted destructive testing or chemical analysis on incoming materials and chemicals. TI and TI suppliers consider certain information to be proprietary, and thus CAS numbers and other limited information may not be available for release.

In no event shall TI's liability arising out of such information exceed the total purchase price of the TI part(s) at issue in this document sold by TI to Customer on an annual basis.

TAPE AND REEL INFORMATION

QUADRANT ASSIGNMENTS FOR PIN 1 ORIENTATION IN TAPE

*All dimensions are nominal

Device	Package Type	Package Drawing	Pins	SPQ	Reel Diameter (mm)	Reel Width W1 (mm)	A0 (mm)	B0 (mm)	K0 (mm)	P1 (mm)	W (mm)	Pin1 Quadrant
DRV8801AQRMJRQ1	WQFN	RMJ	16	3000	330.0	12.4	4.25	4.25	1.15	8.0	12.0	Q2

TAPE AND REEL BOX DIMENSIONS

*All dimensions are nominal

Device	Package Type	Package Drawing	Pins	SPQ	Length (mm)	Width (mm)	Height (mm)
DRV8801AQRMJRQ1	WQFN	RMJ	16	3000	353.0	353.0	32.0

RMJ (S-PWQFN-N16)

PLASTIC SMALL OUTLINE NO-LEAD

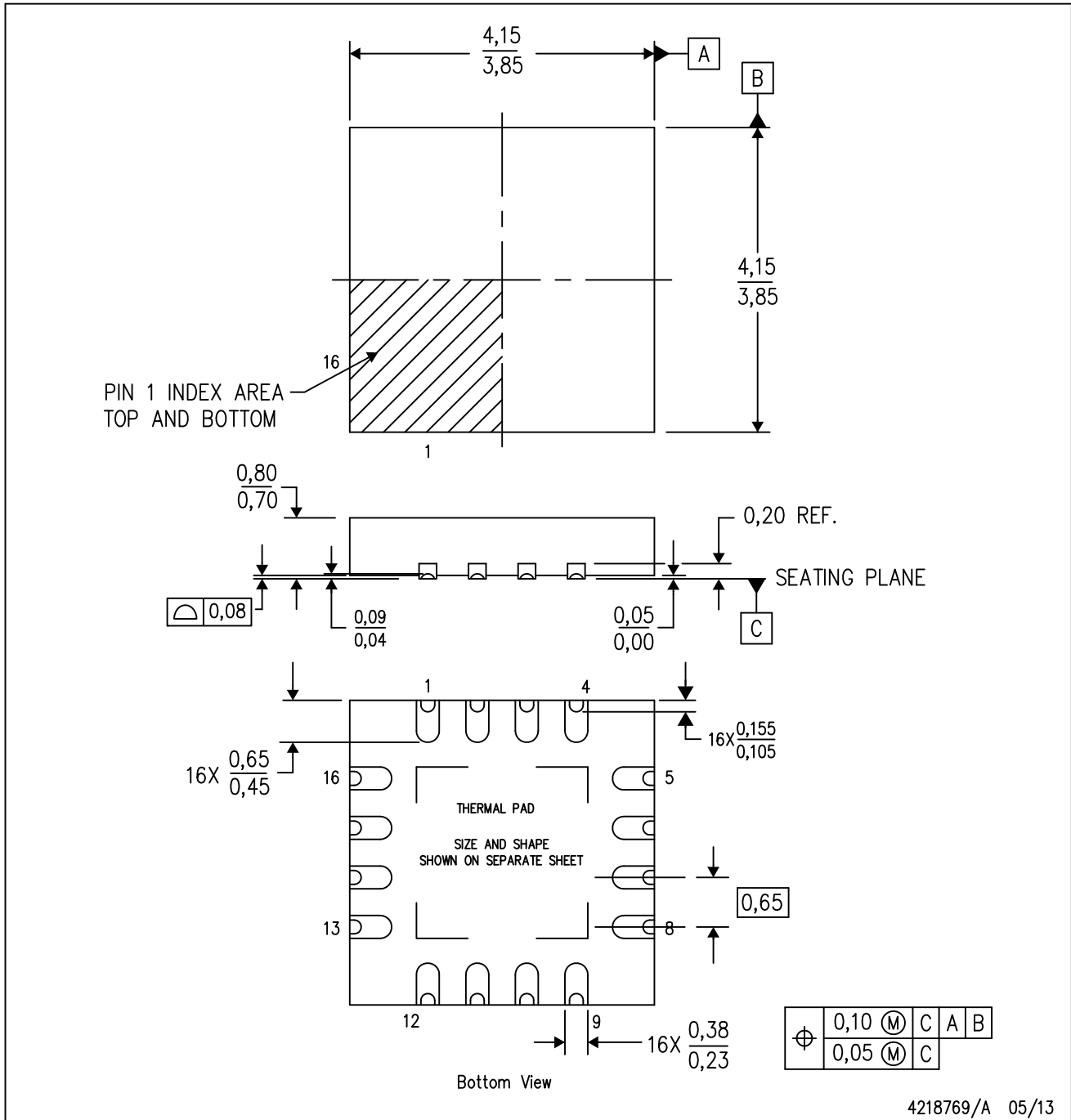

- NOTES:
- All linear dimensions are in millimeters. Dimensioning and tolerancing per ASME Y14.5M-1994.
 - This drawing is subject to change without notice.
 - Quad Flatpack, No-leads (QFN) package configuration.
 - The package thermal pad must be soldered to the board for thermal and mechanical performance.
 - See the additional figure in the Product Data Sheet for details regarding the exposed thermal pad features and dimensions.

THERMAL PAD MECHANICAL DATA

RMJ (S-PWQFN-N16)

PLASTIC QUAD FLATPACK NO-LEAD

THERMAL INFORMATION

This package incorporates an exposed thermal pad that is designed to be attached directly to an external heatsink. The thermal pad must be soldered directly to the printed circuit board (PCB). After soldering, the PCB can be used as a heatsink. In addition, through the use of thermal vias, the thermal pad can be attached directly to the appropriate copper plane shown in the electrical schematic for the device, or alternatively, can be attached to a special heatsink structure designed into the PCB. This design optimizes the heat transfer from the integrated circuit (IC).

For information on the Quad Flatpack No-Lead (QFN) package and its advantages, refer to Application Report, QFN/SON PCB Attachment, Texas Instruments Literature No. SLUA271. This document is available at www.ti.com.

The exposed thermal pad dimensions for this package are shown in the following illustration.

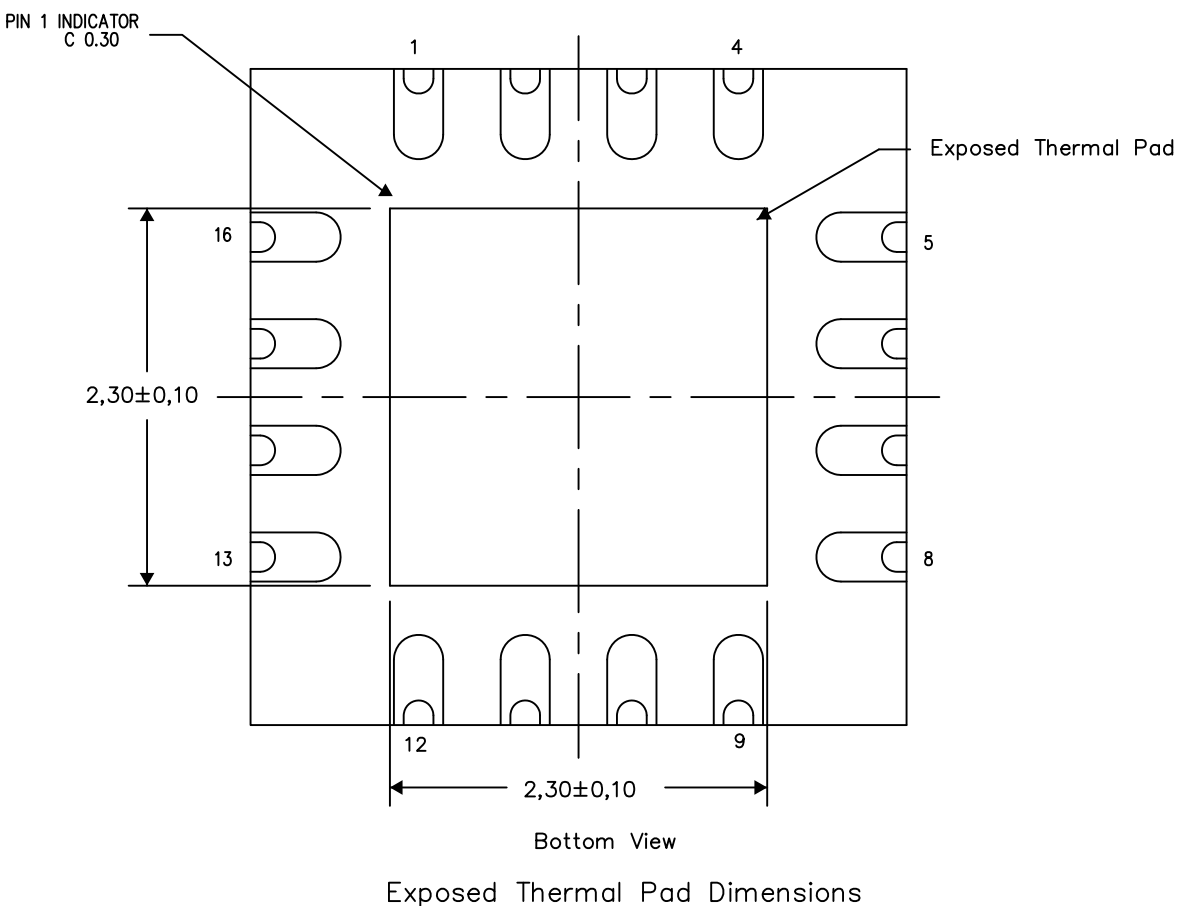

4219300/A 07/13

NOTE: All linear dimensions are in millimeters

重要通知和免责声明

TI“按原样”提供技术和可靠性数据（包括数据表）、设计资源（包括参考设计）、应用或其他设计建议、网络工具、安全信息和其他资源，不保证没有瑕疵且不做任何明示或暗示的担保，包括但不限于对适销性、某特定用途方面的适用性或不侵犯任何第三方知识产权的暗示担保。

这些资源可供使用 TI 产品进行设计的熟练开发人员使用。您将自行承担以下全部责任：(1) 针对您的应用选择合适的 TI 产品，(2) 设计、验证并测试您的应用，(3) 确保您的应用满足相应标准以及任何其他功能安全、信息安全、监管或其他要求。

这些资源如有变更，恕不另行通知。TI 授权您仅可将这些资源用于研发本资源所述的 TI 产品的相关应用。严禁以其他方式对这些资源进行复制或展示。您无权使用任何其他 TI 知识产权或任何第三方知识产权。您应全额赔偿因在这些资源的使用中对 TI 及其代表造成的任何索赔、损害、成本、损失和债务，TI 对此概不负责。

TI 提供的产品受 [TI 的销售条款](#) 或 [ti.com](#) 上其他适用条款/TI 产品随附的其他适用条款的约束。TI 提供这些资源并不会扩展或以其他方式更改 TI 针对 TI 产品发布的适用的担保或担保免责声明。

TI 反对并拒绝您可能提出的任何其他或不同的条款。

邮寄地址：Texas Instruments, Post Office Box 655303, Dallas, Texas 75265
版权所有 © 2025，德州仪器 (TI) 公司